



**HAL**  
open science

# Topological interference management for multi-user wireless networks

Hassan Kallam

► **To cite this version:**

Hassan Kallam. Topological interference management for multi-user wireless networks. Networking and Internet Architecture [cs.NI]. Université de Lyon, 2021. English. NNT : 2021LYSEI062 . tel-03624482

**HAL Id: tel-03624482**

**<https://theses.hal.science/tel-03624482v1>**

Submitted on 30 Mar 2022

**HAL** is a multi-disciplinary open access archive for the deposit and dissemination of scientific research documents, whether they are published or not. The documents may come from teaching and research institutions in France or abroad, or from public or private research centers.

L'archive ouverte pluridisciplinaire **HAL**, est destinée au dépôt et à la diffusion de documents scientifiques de niveau recherche, publiés ou non, émanant des établissements d'enseignement et de recherche français ou étrangers, des laboratoires publics ou privés.



N° d'ordre NNT : 2021LYSEI062

**THÈSE de DOCTORAT DE L'UNIVERSITÉ DE LYON**  
opérée au sein de  
**l'INSA Lyon**

**École Doctorale N° 160**  
**Électronique, Électrotechnique et Automatique**  
**(ED EEA)**

**Spécialité / discipline de doctorat :**  
**Traitement du Signal et de l'Image**

Soutenue publiquement le 28/09/2021, par :  
**Hassan Kallam**

---

# **Topological Interference Management for Multi-User Wireless Networks**

---

Devant le jury composé de :

**Rapporteurs :**

Florian KALTENBERGER

EURECOM, France.

Iñaki ESNAOLA

University of Sheffield, UK.

**Examineurs :**

Laurent CLAVIER

TELECOM Lille, France.

Ghaya REKAYA-BEN OTHMAN

TELECOM Paris, France.

**Directeurs de Thèse :**

Jean-Marie GORCE

INSA Lyon, France.

Leonardo SAMPAIO CARDOSO

INSA Lyon, France.



UNIVERSITY OF LYON  
Doctoral School of Electronics, Electrotechnics and Automation  
(ED EEA)

# THESIS

presented in partial fulfilment of the requirements  
for the degree of Doctor of Philosophy from the University of Lyon,  
the 28/09/2021.

Specialization: Signal and Image Processing

Hassan Kallam

## Topological Interference Management for Multi-User Wireless Networks

Members of the Jury:

**Reviewers:**

Florian KALTENBERGER

Iñaki ESNAOLA

EURECOM, France.

University of Sheffield, UK.

**Examiners:**

Laurent CLAVIER

Ghaya REKAYA-BEN OTHMAN

TELECOM Lille, France.

TELECOM Paris, France.

**Thesis supervisors:**

Jean-Marie GORCE

Leonardo SAMPAIO CARDOSO

INSA Lyon, France.

INSA Lyon, France.



UNIVERSITÉ DE LYON  
Électronique, Électrotechnique et Automatique  
(ED EEA)

# THÈSE

présentée publiquement pour l'obtention  
du diplôme de Docteur de l'Université de Lyon,  
le 28/09/2021.

Spécialité : Traitement du Signal et de l'Image

Hassan Kallam

## Topological Interference Management for Multi-User Wireless Networks

Devant le jury composé de :

**Rapporteurs :**

Florian KALTENBERGER

EURECOM, France.

Iñaki ESNAOLA

University of Sheffield, UK.

**Examineurs :**

Laurent CLAVIER

TELECOM Lille, France.

Ghaya REKAYA-BEN OTHMAN

TELECOM Paris, France.

**Directeurs de Thèse :**

Jean-Marie GORCE

INSA Lyon, France.

Leonardo SAMPAIO CARDOSO

INSA Lyon, France.



## Département FEDORA – INSA Lyon - Ecoles Doctorales

SIGLE	ECOLE DOCTORALE	NOM ET COORDONNEES DU RESPONSABLE
<b>CHIMIE</b>	<b><u>CHIMIE DE LYON</u></b> <a href="https://www.edchimie-lyon.fr">https://www.edchimie-lyon.fr</a> Sec. : Renée EL MELHEM Bât. Blaise PASCAL, 3e étage secretariat@edchimie-lyon.fr	<b>M. Stéphane DANIELE</b> C2P2-CPE LYON-UMR 5265 Bâtiment F308, BP 2077 43 Boulevard du 11 novembre 1918 69616 Villeurbanne <a href="mailto:directeur@edchimie-lyon.fr">directeur@edchimie-lyon.fr</a>
<b>E.E.A.</b>	<b><u>ÉLECTRONIQUE, ÉLECTROTECHNIQUE, AUTOMATIQUE</u></b> <a href="https://edeea.universite-lyon.fr">https://edeea.universite-lyon.fr</a> Sec. : Stéphanie CAUVIN Bâtiment Direction INSA Lyon Tél : 04.72.43.71.70 secretariat.edeea@insa-lyon.fr	<b>M. Philippe DELACHARTRE</b> INSA LYON Laboratoire CREATIS Bâtiment Blaise Pascal, 7 avenue Jean Capelle 69621 Villeurbanne CEDEX Tél : 04.72.43.88.63 <a href="mailto:philippe.delachartre@insa-lyon.fr">philippe.delachartre@insa-lyon.fr</a>
<b>E2M2</b>	<b><u>ÉVOLUTION, ÉCOSYSTÈME, MICROBIOLOGIE, MODÉLISATION</u></b> <a href="http://e2m2.universite-lyon.fr">http://e2m2.universite-lyon.fr</a> Sec. : Sylvie ROBERJOT Bât. Atrium, UCB Lyon 1 Tél : 04.72.44.83.62 secretariat.e2m2@univ-lyon1.fr	<b>M. Philippe NORMAND</b> Université Claude Bernard Lyon 1 UMR 5557 Lab. d'Ecologie Microbienne Bâtiment Mendel 43, boulevard du 11 Novembre 1918 69 622 Villeurbanne CEDEX <a href="mailto:philippe.normand@univ-lyon1.fr">philippe.normand@univ-lyon1.fr</a>
<b>EDISS</b>	<b><u>INTERDISCIPLINAIRE SCIENCES-SANTÉ</u></b> <a href="http://ediss.universite-lyon.fr">http://ediss.universite-lyon.fr</a> Sec. : Sylvie ROBERJOT Bât. Atrium, UCB Lyon 1 Tél : 04.72.44.83.62 secretariat.ediss@univ-lyon1.fr	<b>Mme Sylvie RICARD-BLUM</b> Institut de Chimie et Biochimie Moléculaires et Supramoléculaires (ICBMS) - UMR 5246 CNRS - Université Lyon 1 Bâtiment Raulin - 2ème étage Nord 43 Boulevard du 11 novembre 1918 69622 Villeurbanne Cedex Tél : +33(0)4 72 44 82 32 <a href="mailto:sylvie.ricard-blum@univ-lyon1.fr">sylvie.ricard-blum@univ-lyon1.fr</a>
<b>INFOMATHS</b>	<b><u>INFORMATIQUE ET MATHÉMATIQUES</u></b> <a href="http://edinfomaths.universite-lyon.fr">http://edinfomaths.universite-lyon.fr</a> Sec. : Renée EL MELHEM Bât. Blaise PASCAL, 3e étage Tél : 04.72.43.80.46 infomaths@univ-lyon1.fr	<b>M. Hamamache KHEDDOUCI</b> Université Claude Bernard Lyon 1 Bât. Nautibus 43, Boulevard du 11 novembre 1918 69 622 Villeurbanne Cedex France Tél : 04.72.44.83.69 <a href="mailto:hamamache.kheddouci@univ-lyon1.fr">hamamache.kheddouci@univ-lyon1.fr</a>
<b>Matériaux</b>	<b><u>MATÉRIAUX DE LYON</u></b> <a href="http://ed34.universite-lyon.fr">http://ed34.universite-lyon.fr</a> Sec. : Yann DE ORDENANA Tél : 04.72.18.62.44 yann.de-ordenana@ec-lyon.fr	<b>M. Stéphane BENAYOUN</b> Ecole Centrale de Lyon Laboratoire LTDS 36 avenue Guy de Collongue 69134 Ecully CEDEX Tél : 04.72.18.64.37 <a href="mailto:stephane.benayoun@ec-lyon.fr">stephane.benayoun@ec-lyon.fr</a>
<b>MEGA</b>	<b><u>MÉCANIQUE, ÉNERGÉTIQUE, GÉNIE CIVIL, ACOUSTIQUE</u></b> <a href="http://edmega.universite-lyon.fr">http://edmega.universite-lyon.fr</a> Sec. : Stéphanie CAUVIN Tél : 04.72.43.71.70 Bâtiment Direction INSA Lyon mega@insa-lyon.fr	<b>M. Jocelyn BONJOUR</b> INSA Lyon Laboratoire CETHIL Bâtiment Sadi-Carnot 9, rue de la Physique 69621 Villeurbanne CEDEX <a href="mailto:jocelyn.bonjour@insa-lyon.fr">jocelyn.bonjour@insa-lyon.fr</a>
<b>ScSo</b>	<b><u>ScSo*</u></b> <a href="https://edsciencessociales.universite-lyon.fr">https://edsciencessociales.universite-lyon.fr</a> Sec. : Mélina FAVETON INSA : J.Y. TOUSSAINT Tél : 04.78.69.77.79 melina.faveton@univ-lyon2.fr	<b>M. Christian MONTES</b> Université Lumière Lyon 2 86 Rue Pasteur 69365 Lyon CEDEX 07 <a href="mailto:christian.montes@univ-lyon2.fr">christian.montes@univ-lyon2.fr</a>

\*ScSo : Histoire, Géographie, Aménagement, Urbanisme, Archéologie, Science politique, Sociologie, Anthropologie



# Abstract

Topological Interference Management (TIM) allows studying the Degrees of Freedom (DoF) of partially connected linear interference communication networks, where the Channel State Information at the Transmitter (CSIT) is restricted to the topology of the network, i.e., a knowledge of which interference links are weak and which are strong. In this thesis, we consider TIM for infinite downlink cellular networks in the one-dimensional (1D) linear and the two-dimensional (2D) hexagonal models. We consider uniformly distributed users in each cellular cell, effectively creating a continuous distribution of users, aiming to study user classes based on different interference profiles rather than on actual individual users' positions. We also consider the construction of the TIM network topology by analyzing different interference thresholds. Unlike previous works, we use TIM at the user class level to find the system's DoF independent of the actual user position. Then, after proposing a fractional coloring scheme that can achieve the optimal DoF solution, a trade-off between DoF and Signal to Interference Ratio (SIR) is given. This thesis also presents a new approach to construct an interference topology for the unicast TIM problem of multi-user wireless networks. Based on our interference topology construction approach, we are able to evaluate the achievable rate's theoretical limit, in the asymptotic Signal to Noise Ratio (SNR) regime, for the underlying wireless network and not just for its topological interference representation. This new approach allows us to cope with the finite SNR regime and not just with the asymptotic SNR regime with the DoF analysis. A new SNR independent interference threshold parameter is proposed and we evaluate the achievable symmetric rates of the wireless network in both the finite SNR regime and the asymptotic SNR regime. Then, we present outer bound solutions on the new normalized interference threshold parameter for interference topologies with half-DoF-feasibility, considering both an orthogonal resource allocation and Interference Alignment (IA). These bounds specify if a given half-DoF-feasible interference topology can be, in terms of the achievable rate, the best topology or not. Using this result, we limit the search space in the normalized interference threshold parameter range, to find half-DoF-feasible interference topologies having the possibility to be the best topologies in terms of the achievable rate. Finally, this thesis considers a case study on TIM for small-scale wireless networks, in which, we consider the TIM problem for four users wireless networks using our proposed interference topology construction approach. Then, we apply the achievable rates analysis, proposed under the new interference topology construction approach, for all interference topologies with half-DoF-feasibility, through both orthogonal sharing and IA, in the TIM problem of four users wireless networks.

# Résumé

La gestion d'interférence topologique (de l'Anglais : Topological Interference Management - TIM) permet l'étude des degrés de liberté (de l'Anglais : Degrees of Freedom - DoF) de réseaux sans fils soumis à l'interférence partielle et dont la connaissance de l'état du canal est limitée seulement à la topologie du réseaux, autrement dit, quels liens interférents sont faibles et quels sont forts.

Dans ce manuscrit de thèse, nous considérons l'application de TIM pour les réseaux cellulaires d'une dimension (1D) linéaires et les réseaux cellulaires de deux dimensions (2D) hexagonales. Nous considérons le cas des utilisateurs uniformément distribués dans chaque cellule, ce qui donne une distribution continue d'utilisateurs. Ceci nous permet d'étudier la performance des classes d'utilisateurs au contraire des positions des utilisateurs individuels, comme a été fait auparavant. Nous considérons aussi la construction de la topologie au travers de l'analyse des seuils de l'interférence. Contrairement aux travaux existents nous utilisons TIM au niveau des classes des utilisateurs, ce qui nous permet de trouver la performance système en DoF indépendante de la position précise de chaque utilisateur. Ensuite, après avoir proposé un schéma de coloration fractionnaire des graphes resultants, pouvant atteindre la solution optimale de DoF, un compromis entre DoF et rapport signal sur interférence (de l'Anglais : Signal to Interference Ratio - SIR) est proposé.

Cette thèse propose également une nouvelle approche pour construire une topologie d'interférence pour le problème TIM unicast des réseaux sans fil multi-utilisateurs. Fondée sur notre approche de construction de topologie d'interférence, nous pouvons évaluer la limite théorique des taux atteignables, dans le régime rapport signal sur bruit (de l'Anglais : Signal to Noise Ratio - SNR) asymptotique, pour le réseau sans fil sous-jacent et pas seulement pour sa représentation topologique d'interférence. Cette nouvelle approche nous permet de traiter le régime de SNR fini et pas seulement le régime SNR asymptotique avec l'analyse DoF. Un nouveau paramètre liée au seuil d'interférence, indépendant du SNR, est proposé et nous évaluons les débits symétriques réalisables du réseau sans fil, à la fois en régime SNR fini et en régime SNR asymptotique. Ensuite, nous présentons les bornes supérieures sur ce nouveau paramètre de seuil d'interférence normalisé pour les topologies d'interférence ayant une faisabilité en demi-DoF (de l'Anglais : Half-DoF-feasible), en considérant à la fois une allocation de ressources orthogonale et l'alignement d'interférence (de l'Anglais : Interference Alignment - IA). Ces limites spécifient si une topologie d'interférence donnée réalisable en demi-DoF peut être, en termes de taux réalisable, la meilleure topologie ou non. En utilisant ce résultat, nous limitons l'espace de recherche dans la plage de paramètres du seuil d'interférence normalisée, pour trouver des topologies d'interférence réalisables à demi-DoF ayant la possibilité d'être les meilleures topologies en termes de taux réalisable.

Enfin, cette thèse considère une étude de cas sur le TIM pour les réseaux sans fil à petite échelle, dans laquelle, nous considérons le problème TIM pour les réseaux à quatre utilisateurs en employant notre approche de construction de topologie d'interférence proposée. Ensuite, nous appliquons l'analyse des débits réalisables, proposée dans le cadre de la nouvelle approche

de construction de topologie d'interférence, pour toutes les topologies d'interférence réalisables à demi-DoF, à la fois par partage orthogonal et IA, dans le problème TIM de réseaux sans fil à quatre utilisateurs.

# Publications

- [1]\* Hassan Kallam, Hiba Bawab, Oussama Bazzi, Youssef Nasser, Jean-François H elard. On the Ergodic Capacity in Multicarrier Cognitive Radio Systems under Power Constraints. ICUMT 2017 - 9th International Congress on Ultra Modern Telecommunications and Control Systems, Nov 2017, Munich, Germany.
- [2] Hassan Kallam, Leonardo S. Cardoso, and Jean-Marie Gorce. Addressing Inter-PMR Interference with Topological Interference Management. Technical Report, Fed4PMR project, Dec 2018, CITI Lab., INSA Lyon, Villeurbanne, France.
- [3] Hassan Kallam, Leonardo Cardoso, Jean-Marie Gorce. Topological Interference Management: Trade-off Between DoF and SIR for Cellular Systems. ICT 2019 - 26th International Conference on Telecommunications, Apr 2019, Hanoi, Vietnam.
- [4] Hassan Kallam, Leonardo Cardoso, Jean-Marie Gorce. On the Impact of Normalized Interference Threshold for Topological Interference Management. EuCNC 2020 European Conference on Networks and Communications, Jun 2020, Dubrovnik, Croatia.

\* Related to previous work and published during my PhD.

## Contents

<b>Acronyms</b>	<b>xvi</b>
<b>1 Introduction</b>	<b>1</b>
<b>2 Background</b>	<b>3</b>
2.1 Topological Interference Management for Wireless Networks . . . . .	3
2.1.1 Wireless Network Model . . . . .	3
2.1.2 Instantiation of a TIM Problem . . . . .	5
2.2 TIM Problem for Wireless Networks . . . . .	7
2.2.1 DoF Analysis . . . . .	7
2.2.2 Graph Models for DoF Analysis . . . . .	8
2.2.3 Resource Allocation Strategies . . . . .	12
2.3 Known DoF Results from TIM and IC . . . . .	14
2.3.1 Half-DoF-Feasible Networks . . . . .	15
2.3.2 $1/K$ Optimal Symmetric DoF for $K$ -Unicast TIM Problems . . . . .	16
2.3.3 Half-DoF-Unfeasible Networks . . . . .	16
2.3.4 Algorithmic Approaches for TIM Problem . . . . .	18
2.3.5 DoF Optimality of Fractional Coloring in TIM . . . . .	18
2.4 Achievable Rates under TIM . . . . .	19
2.5 Conclusion . . . . .	20
<b>3 TIM for Cellular Networks</b>	<b>23</b>
3.1 Single-Layer Interference Topology . . . . .	24
3.1.1 Linear Cellular Network . . . . .	24
3.1.2 Hexagonal Cellular Network . . . . .	26
3.2 Multi-Layer Interference Topology . . . . .	29
3.2.1 Network Model and Interference Topology . . . . .	29
3.2.2 TIM problem: DoF Solution . . . . .	29
3.2.3 Aligned Frequency Reuse . . . . .	31
3.2.4 DoF Gain of Optimal Scheme Over Conventional Frequency Reuse . . . . .	32
3.2.5 Conclusion . . . . .	32
3.3 Linear Cellular Network with Uniformly Distributed Users . . . . .	33
3.3.1 Infinite 1D (Linear) Downlink Cellular Network Model . . . . .	33
3.3.2 TIM Network Topology . . . . .	33
3.3.3 TIM: DoF Analysis . . . . .	35
3.3.4 Trade-off Analysis Between DoF and SIR . . . . .	37
3.3.5 Conclusion . . . . .	40
3.4 Hexagonal Cellular Network with Uniformly Distributed Users . . . . .	41
3.4.1 Infinite 2D (Hexagonal) Downlink Cellular Network Model . . . . .	41
3.4.2 TIM Network Topology . . . . .	43
3.4.3 TIM: DoF Analysis . . . . .	44

3.4.4	Trade-off Analysis Between DoF and SIR . . . . .	46
3.4.5	Conclusion . . . . .	48
<b>4</b>	<b>Achievable Rates in TIM</b>	<b>49</b>
4.1	System Model . . . . .	49
4.2	The Classical TIM Formulation . . . . .	51
4.3	TIM: A New Formulation for the Topology Construction . . . . .	52
4.3.1	Normalized Network Model . . . . .	52
4.3.2	SNR-Independent Interference Threshold . . . . .	53
4.3.3	Interference Topology: Interference Classification . . . . .	54
4.3.4	Fundamental Trade-off between DoF and SINR Maximization . . . . .	55
4.4	Achievable Rates in TIM . . . . .	55
4.5	Extreme Interference Topologies: Achievable Rate Analysis . . . . .	57
4.6	Fundamental Limits on $\beta_T^*$ for Interference Topologies with Half-DoF-Feasibility	59
4.7	Conclusion . . . . .	61
<b>5</b>	<b>TIM for Small Scale Wireless Networks: Four Users Networks</b>	<b>63</b>
5.1	System Model . . . . .	63
5.1.1	Initial Network Model . . . . .	63
5.1.2	Normalized Network Model for TIM . . . . .	64
5.2	TIM: Interference Topology Formulation . . . . .	65
5.2.1	SNR-Independent Interference Threshold . . . . .	65
5.2.2	Fundamental Trade-off between DoF and SINR Maximization . . . . .	66
5.3	Achievable Rates under the Interference Topology Formulation . . . . .	66
5.4	Interference Topology Graph and Conflict Graph of the 4 Users Unicast TIM Problem . . . . .	67
5.5	Half-DoF Through Orthogonal Sharing . . . . .	70
5.6	Half-DoF Through Interference Alignment . . . . .	74
5.7	Half-DoF Topologies Versus Extreme Topologies . . . . .	78
5.8	Half-DoF Topologies: Orthogonal Sharing Versus IA . . . . .	79
5.9	Conclusion . . . . .	81
<b>6</b>	<b>Conclusion</b>	<b>83</b>
	<b>Bibliography</b>	<b>85</b>

## List of Figures

2.1	Wireless communication network with $K$ users. . . . .	4
2.2	Wireless network: (a) BS 1 sends message $W_1$ to mobile node 1. BS 2 sends message $W_2$ to mobile node 2 and sends message $W_3$ to mobile node 3. BS 3 sends message $W_4$ to mobile node 4 and sends message $W_5$ to mobile node 5. Each mobile node is subject to interference from every BS that does not send a message to it. (b) BS 1 is abstracted as message source $S_1$ . BS 2 is abstracted as message sources $S_2$ and $S_3$ . BS 3 is abstracted as message sources $S_4$ and $S_5$ . Each mobile node is abstracted as a message destination, i.e., mobile node 3 that desires message $W_3$ is abstracted as message destination $D_3$ . . . . .	5
2.3	TIM instance: partially connected wireless network. . . . .	8
2.4	Interference topology graph of the TIM instance in Fig. 2.3 associated to 5-unicast TIM problem of the wireless network given in Fig. 2.2(b). . . . .	9
2.5	(a) Alignment graph and (b) conflict graph for the interference topology of Fig. 2.4. . . . .	10
2.6	Interference topology graph associated to 5-unicast TIM problem of the wireless network given in Fig. 2.2(b), where each BS in Fig. 2.2(a) is able to cancel the interference between its own messages. . . . .	11
2.7	(a) Alignment graph and (b) conflict graph for the interference topology of Fig. 2.6. . . . .	11
2.8	The demand graph for the interference topology of Fig. 2.4. . . . .	12
2.9	(a) Five-unicast TIM problem and (b) its conflict graph [1]. . . . .	15
3.1	Infinite 1D (linear) downlink cellular network [1]. . . . .	25
3.2	Infinite linear cellular model. (a) Conventional frequency reuse [1]. (b) Aligned frequency reuse [1]. The red arrows indicate the choice of the mobile user to be served within each active cell. The remaining mobile users are turned off. . . . .	25
3.3	Infinite 2D (hexagonal) downlink cellular network. . . . .	27
3.4	Infinite hexagonal cellular model. (a) Conventional frequency reuse [1]. (b) Aligned frequency reuse [1]. The red arrows indicate the choice of the mobile user to be served within each active cell. The remaining mobile users are turned off. . . . .	28
3.5	Multi-layer interference topology for infinite 1D (linear) cellular network. . . . .	30
3.6	The conflict graph of the $\lambda$ th-layer interference topology in Fig. 3.5 when $\lambda = 1$ . . . . .	31
3.7	Aligned frequency reuse, when $\lambda = 1$ . The red arrows indicate the choice of the mobile user to be served within each active cell. The remaining mobile users are turned off. . . . .	32
3.8	Infinite linear downlink cellular network model. . . . .	34
3.9	The TIM network topology of the infinite linear downlink cellular network in Fig. 3.8. . . . .	34
3.10	The user class based conflict graph of the TIM network topology in Fig. 3.9. . . . .	36
3.11	DoF per any cell as function of the interference design parameter $p$ . . . . .	38

3.12	Fractional coloring scheme for the TIM problem of the TIM network topology shown in Fig. 3.9. . . . .	38
3.13	Worst user SIR as function of the interference design parameter $p$ . . . . .	40
3.14	Cell Rate as function of the interference design parameter $p$ . . . . .	41
3.15	Infinite hexagonal downlink cellular network model. . . . .	42
3.16	The TIM network topology of the infinite hexagonal downlink cellular network in Fig. 3.15. . . . .	43
3.17	The user class based conflict graph of the TIM network topology in Fig. 3.16. The 17 different colors shown in this figure correspond to the fractional coloring scheme solution in section 3.4.4. . . . .	45
3.18	DoF per any cell as function of the interference distance $D$ . . . . .	46
3.19	Cell Rate as function of the interference distance $D$ . . . . .	47
4.1	Wireless communication network with $K$ users. . . . .	50
4.2	Normalized network model with $K = 5$ . . . . .	53
4.3	$\beta_3^*$ outer bounds for different $\beta_m$ values. (We refer in this figure to the $\beta_{\mathcal{T}}^*$ outer bound, defined in theorem 19, by $\beta_3^*$ ). . . . .	61
4.4	$\beta_{ia}^*$ outer bounds for different $\beta_m$ values and with $N_a = 3$ . (We refer in this figure to the $\beta_{\mathcal{T}}^*$ outer bound, defined in theorem 20, by $\beta_{ia}^*$ ). . . . .	62
5.1	Wireless communication network with 4 users. . . . .	64
5.2	Normalized network model with $K = 4$ . . . . .	65
5.3	The interference topology graph and the conflict graph of a 4 users unicast TIM instance. . . . .	68
5.4	All possible unlabeled conflict graphs. . . . .	69
5.5	Unlabelled conflict graphs dominations. . . . .	70
5.6	Undominated orthogonal sharing Half-DoF unlabeled conflict graphs. . . . .	71
5.7	The bi-directed interference topologies of the undominated orthogonal sharing Half-DoF unlabeled conflict graphs $C_6$ and $C_8$ . . . . .	72
5.8	Complement graphs of the bi-directed interference topologies of the undominated orthogonal sharing Half-DoF unlabeled conflict graphs $C_6$ and $C_8$ . . . . .	73
5.9	IA Half-DoF unlabeled conflict graphs. . . . .	75
5.10	Directed-cyclic interference topologies of the IA Half-DoF unlabeled conflict graphs $C_9$ and $C_{10}$ . . . . .	76
5.11	Alignment sets when non-conflicting alignment sets are merged into one alignment set, for the directed-cyclic interference topologies of $C_9$ and $C_{10}$ . . . . .	77
5.12	Complement graphs of the directed-cyclic interference topologies of the IA Half-DoF unlabeled conflict graphs $C_9$ and $C_{10}$ . . . . .	77
5.13	$\beta_{6,8}^{**}$ outer bound versus SNR and for different $\beta_m$ values. . . . .	80
5.14	$\beta_{9,10}^{**}$ outer bound versus SNR and for different $\beta_m$ values. . . . .	81
5.15	IA Half-DoF outperforms orthogonal sharing Half-DoF: $\beta_{9,10}^{**}$ outer bound versus SNR and for different $\beta_{6,8}^{**}$ values. . . . .	82



# Acronyms

<b>1D</b>	one-dimensional
<b>2D</b>	two-dimensional
<b>BS</b>	Base Station
<b>CSI</b>	Channel State Information
<b>CSIR</b>	Channel State Information at the Receiver
<b>CSIT</b>	Channel State Information at the Transmitter
<b>DoF</b>	Degrees of Freedom
<b>IA</b>	Interference Alignment
<b>IC</b>	Index Coding
<b>i.i.d.</b>	independent and identically distributed
<b>LRMC</b>	Low Rank Matrix Completion
<b>RX</b>	Receiver
<b>SIC</b>	Successive Interference Cancellation
<b>SINR</b>	Signal to Interference Plus Noise Ratio

<b>SIR</b>	Signal to Interference Ratio
<b>SNR</b>	Signal to Noise Ratio
<b>TDMA</b>	Time Division Multiple Access
<b>TIM</b>	Topological Interference Management
<b>TX</b>	Transmitter





---

# Introduction

In spite of all recent advancements concerning wireless communications systems, interference remains one of the most critical “Achilles heels” of multi-user wireless systems, a problem that naturally arises due to the broadcast nature of radio transmissions. Traditionally, interference has been dealt with the orthogonalization of resources, essentially avoiding interference [2]. However, the strict structure in the partition of resources is known to provide lackluster performance in many situations. Facing the problem of interference has become all the more important nowadays due to the need to extract more and more capacity out of an ever-shrinking pool of spectral resources.

Dealing with interference usually requires some sort of coordination between transmitting nodes to minimize its impact on the overall system performance. Such coordination usually comes in the form of resource management, finding orthogonal resources that can be assigned to different nodes, thus avoiding interference. Other traditional interference management techniques such as IA [3] and interference cancellation [4] have been investigated before based on the assumption of having a perfect knowledge of critical information at the transmitters, i.e., CSIT. These techniques, such as IA [5, 6] for dealing with interference rely on CSIT or Channel State Information at the Receiver (CSIR), cooperation between transmitters and receivers, and other complicated signaling techniques. While such techniques perform very well in controlled settings, they have proven complicated to implement in real life systems and are not easily scalable to large networks. The Channel State Information (CSI) is usually not available at the transmitters, rendering the assumption of perfect knowledge for the CSIT unrealistic. In this sense, more realistic interference management schemes have been explored based on partial CSIT [7], [8].

In [1], Jafar pioneered a very interesting technique called TIM that has the benefit of reducing the CSIT requirement to a simple interference topology information. Such information represents only a distinction between weak and significant interference channels [1]. TIM is a clever way of understanding the impact of interference in large wireless systems, where channel knowledge is not needed beyond the *topology* of the interference links. This technique TIM, bases its analysis on a classification of the interference links into relevant or non-relevant, giving rise to a topology. Based on the topology, graph theory can be used to characterize the underlying network with respect to its DoF. An equivalence relation between the TIM problem

and the index coding problem [9, 10], is shown in [1]. Optimal solutions to both TIM and index coding problems are shown to be achievable through IA. Solutions for different classes of topologies for the index coding and TIM problems have been considered in [1, 11, 12, 13, 14, 15].

Defining an interference topology is crucial to perform TIM analysis. However, different interference thresholds yield different interference topologies. As a matter of fact, even at a given interference threshold, different classifications of interference links may be considered, changing the interference topology accordingly. In this thesis, we will focus on defining a unique interference topology for a wireless network at a given interference threshold. As such some of the contributions of this thesis are as follows. First, unlike [1, 16, 12, 13], where a discrete distribution of mobile users has been considered, we adopt a continuous uniform distribution of mobile users, where mobile users that share the same interference profile can be grouped into a *user class*. We then apply TIM at the user class level to extract DoF information for the system independent of the actual mobile user position. This approach is useful to characterize the average performance of the network. Second, we consider the effect of the interference threshold on the interference topology and the DoF of the system. By varying the interference threshold, an interesting trade-off arises: either we have a loosely connected interference topology, hence more DoF, but at the same time a higher interference since mobile users contend more to access the medium, or a densely connected interference topology, hence less DoF, but at the same time a lower interference since mobile users will choose more conservative access to the medium. In this thesis, we look for the best operating point in terms of interference threshold.

The TIM problem has also been extended in various directions, where TIM schemes relying on different system configurations have been investigated in [1, 17, 18, 19, 20, 21, 22, 23, 24, 25, 26]. For a detailed overview of the TIM for wireless networks, the interested readers are referred to [27] and the references therein. A common point of these works is that they depend heavily on the interference topology construction model given in [1]. Therein, an interference topology is fixed whatever power levels are used by the transmitters. While fixing the interference topology allows for easier analysis, as developed in [1], it has an important drawback since, in reality, the interference topology depends on the transmission power levels of all transmitters and we will not have the same interference topology for different transmission powers. In this thesis, we propose a new interference topology construction approach, for the TIM problem of wireless networks, that addresses this drawback. We introduce a new finite SNR framework that is able to control the interference topology more accurately and with more flexibility. This new interference topology construction approach can be used more efficiently to deal with the non-asymptotic SNR regime. Also, with this approach, we are able to cope with the finite SNR regime and to evaluate the impact of the interference threshold used to build the interference topology.

The remainder of this thesis unfolds as follows. Chapter 2 presents the required background for this thesis on TIM for wireless networks. Chapter 3 considers the TIM problem for infinite downlink cellular networks. Chapter 4 presents a new interference topology construction approach for the TIM problem of wireless networks and presents the achievable symmetric rates of wireless networks under TIM with the new interference topology construction approach. Chapter 5 considers a case study on TIM, for small-scale wireless networks, with the new interference topology construction approach. Finally, chapter 6 concludes this thesis.

# — 2 —

---

## Background

In [1], Jafar pioneered a very interesting technique called TIM that has the benefit of reducing the CSIT requirement to a simple interference topology information. Such information represents only a distinction between significant and non-significant interference channels [1]. Consequently, an interference topology only considers the direct links as well as the significant interference links, disregarding the non-significant interference links, which greatly simplifies the analysis of such networks. TIM has shown to be promising in the study of the DoF of many-node systems taking into consideration the interference through the knowledge of the interference topology.

In this chapter, we present the TIM for wireless networks as introduced in [1]. This chapter introduces the required background for this thesis on the TIM problem for wireless networks. An achievability analysis in terms of information transmission rates for wireless networks, when TIM is used, is also introduced in this chapter.

### 2.1 Topological Interference Management for Wireless Networks

#### 2.1.1 Wireless Network Model

Let us start by defining the wireless network model, as follows. Consider a wireless communication network, as shown in Fig. 2.1 consisting of  $K$  Transmitters (TXs), labeled,  $S_1, S_2, \dots, S_K$ , and  $K$  Receivers (RXs), labeled,  $D_1, D_2, \dots, D_K$ .

#### Channel Model

The channel input-output relationships are defined as

$$\begin{bmatrix} y_1(n) \\ y_2(n) \\ \vdots \\ y_K(n) \end{bmatrix} = \begin{bmatrix} h_{11} & h_{12} & \dots & h_{1K} \\ h_{21} & h_{22} & \dots & h_{2K} \\ \vdots & \vdots & \vdots & \vdots \\ h_{K1} & h_{K2} & \dots & h_{KK} \end{bmatrix} \begin{bmatrix} x_1(n) \\ x_2(n) \\ \vdots \\ x_K(n) \end{bmatrix} + \begin{bmatrix} z_1(n) \\ z_2(n) \\ \vdots \\ z_K(n) \end{bmatrix} \quad (2.1)$$

where, over the  $n$ th channel use,  $x_j(n)$  is the transmitted symbol from message source  $S_j$ ,  $j \in \{1, 2, \dots, K\}$ ,  $y_i(n)$  is the received symbol at message destination  $D_i$ ,  $i \in \{1, 2, \dots, K\}$ ,

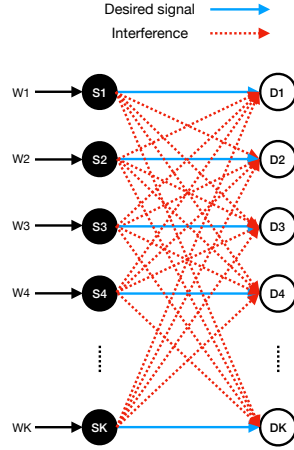

Figure 2.1: Wireless communication network with  $K$  users.

$z_i(n)$  is the additive noise at message destination  $D_i$ , and  $h_{ij}$  is the constant channel coefficient between message source  $S_j$  and message destination  $D_i$ . All symbols belong to the field  $\mathbb{C}$ . We also denote  $g_{ij} = |h_{ij}|^2$ , the flat fading channel gain associated to each source-destination link. The term  $z_i(n)$  is the independent and identically distributed (i.i.d.) complex circularly symmetric additive white Gaussian noise term, with zero mean and variance  $N_0$ . The channel coefficients are supposed constant during one communication round.

### Messages Transmissions and Interference

In [1], Jafar considers a very broad model, where each TX may host several queues of traffic, referred to as *messages*, and each message can be desired by several RXs. In addition, each RX may desire several messages. In the context of our study, however, we restrict the model to *unicast* scenarios where each message is supposed to be desired by one and only one RX. On the opposite side, in the downlink, each TX may have several messages to be transmitted and therefore one TX may host several messages. In the uplink, each message is sent to a designated TX, and therefore a RX may claim several messages. However, in this thesis, we will consider only the downlink case, and each RX is supposed to request only one message.

Let  $\mathcal{W} = \{W_1, W_2, \dots, W_K\}$  be the set of all messages to be transmitted in the network. We assume that the network supports unicast transmissions, where TX  $S_k$ ,  $k \in \{1, 2, \dots, K\}$ , sends a unique message  $W_k$  to a unique RX  $D_k$ . Each message  $W_k$  has a unique message source  $S_k$  and a unique message destination  $D_k$ . This scenario, when each message is desired by only one message destination, is referred to as the *multiple unicast* setting, denoted as  $K$ -unicast scenario [1]. Each TX  $S_k$  uses a power  $P_k$  to transmit its unique message  $W_k$ , and each RX  $D_k$  is subject to interference from every TX  $S_{k'}, k' \in \{1, 2, \dots, K\}/\{k\}$ .

The developments in this model are also valid for a broadcast style channel where each TX  $S_k$  aims at transmitting  $M_k$  unique messages,  $M_k \leq K$ , to  $M_k$  unique RXs. Indeed, this setting can be considered as the point-to-point one by splitting each TX  $S_k$  into  $M_k$  independent co-located TXs. Let us consider the example in Fig. 2.2(a), representing a wireless network made of three Base Stations (BSs) and five mobile nodes. It is abstracted in Fig. 2.2(b), where each node on the left stands for a message source (i.e., TX) and each node on the right holds for a message destination (i.e., RX), in which the BSs who have several messages to send are

abstracted as independent but interfering message sources and each mobile node is abstracted as a message destination.

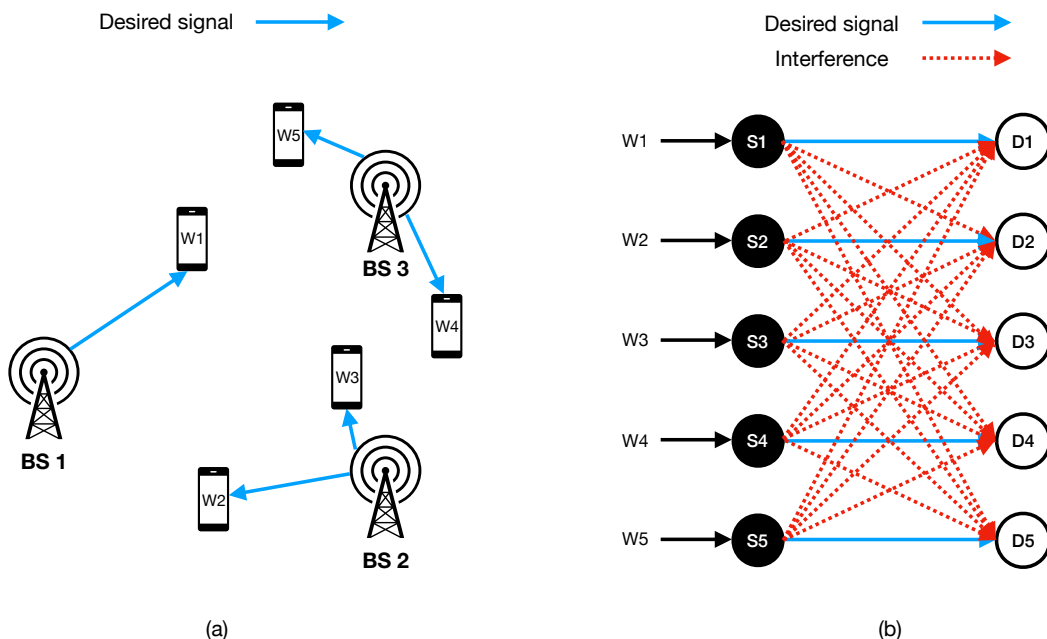

Figure 2.2: Wireless network: (a) BS 1 sends message W1 to mobile node 1. BS 2 sends message W2 to mobile node 2 and sends message W3 to mobile node 3. BS 3 sends message W4 to mobile node 4 and sends message W5 to mobile node 5. Each mobile node is subject to interference from every BS that does not send a message to it. (b) BS 1 is abstracted as message source S1. BS 2 is abstracted as message sources S2 and S3. BS 3 is abstracted as message sources S4 and S5. Each mobile node is abstracted as a message destination, i.e., mobile node 3 that desires message W3 is abstracted as message destination D3.

The wireless network includes two kinds of communication links: the desired links, i.e., the links  $S_k \rightarrow D_k$ ,  $\forall k \in \{1, 2, \dots, K\}$ , and the interference links, i.e., the links  $S_{k'} \rightarrow D_k$ ,  $\forall k, k' \in \{1, 2, \dots, K\}$  and  $k' \neq k$ .

## 2.1.2 Instantiation of a TIM Problem

### Interference Topology

From a theoretical point of view, each TX  $S_k$ ,  $k \in \{1, 2, \dots, K\}$ , is supposed to generate interference to all RXs  $D_{k'}$ ,  $\forall k' \in \{1, 2, \dots, K\}$  and  $k' \neq k$ , but the interference level depends on the transmission powers  $P_k$  and on the distance between TX  $S_k$  and RX  $D_{k'}$ , or more generally on the channel gain between  $S_k$  and  $D_{k'}$ , noted  $g_{k'k}$ .

TIM [1] bases its analysis on a classification of the interference links into significant and weak, giving rise to an interference topology. It is commonly accepted that below a certain level, the interference is negligible, but this is just a rough approximation of the reality as multiple interference may accumulate and contribute to a significant increase of the background



noise. To have a simplified but accurate interference topology, Jafar proposed two important constraints [1]:

1. The average transmit power at each TX  $S_j$ ,

$$P_j := \frac{1}{N} \left[ \sum_{n=1}^N |x_j(n)|^2 \right], \quad (2.2)$$

where  $N$  is the number of channel uses, is set to ensure the following nominal interference-free SNR for all desired links  $S_j \rightarrow D_j$ , given as

$$\frac{g_{jj}P_j}{N_0} \geq \gamma, \quad \forall j \in \{1, 2, \dots, K\}, \quad (2.3)$$

where  $\gamma$  denotes the desired SNR target for all desired links.

2. Once the transmission powers  $P_j$  are chosen, the interference level at each  $D_i$ , is fixed and given by

$$I_i = \sum_{j=1; j \neq i}^K g_{ij}P_j. \quad (2.4)$$

An interference topology can be determined in which for each destination  $D_i$ , the interference links set,  $\mathcal{I}_i = \{S_j \rightarrow D_i; j \in \{1, 2, \dots, K\}, j \neq i\}$ , is divided into two subsets, a set of significant interference links  $\mathcal{S}_i$  and a set of weak interference links  $\bar{\mathcal{S}}_i$ , in which  $\mathcal{I}_i = \mathcal{S}_i \cup \bar{\mathcal{S}}_i$  and  $\mathcal{S}_i \cap \bar{\mathcal{S}}_i = \emptyset$ . This decomposition is not necessarily unique as it depends on the different possible combinations of the interference links. In [1], the set  $\bar{\mathcal{S}}_i$  is chosen arbitrarily such that its elements' sum-interference verifies

$$\sum_{\{S_j \rightarrow D_i\} \in \bar{\mathcal{S}}_i} g_{ij}P_j \leq N_0, \quad (2.5)$$

with  $\mathcal{S}_i$  taken as the complement of  $\bar{\mathcal{S}}_i$ .

Then, interference topology in TIM is an interference links classification that only allows a distinction, at each destination  $D_i$ , between weak interference links, i.e., the interference links that have cumulative interference contribution at  $D_i$  below the interference threshold, and significant interference links, i.e., the interference links that have cumulative interference contribution at  $D_i$  above the interference threshold.

In TIM, the corresponding channel coefficients of the weak interference links are zero, while the corresponding channel coefficients of the significant interference links are set to one. This corresponds to a binarization of the original wireless network and we call it as a TIM binarization.

### Channel State Information

The following CSI assumptions are associated to TIM.

1. All TXs and RXs know the interference topology information, i.e., they know which interference links are weak and which are significant.

2. There is no CSIT beyond the interference topology information.
3. The CSIR only includes, besides the interference topology information, the knowledge of the desired channel coefficients at each RX.

### Achievable Rates

Each message  $W \in \mathcal{W}$  is a random variable uniformly distributed in  $\{1, 2, \dots, 2^{N \cdot R(W)}\}$ , where  $N$  is the number of channel uses considered for the transmission of the set  $\mathcal{W}$ , and  $R(W)$  is the rate associated to the transmission of  $W$ . The vector  $\mathbf{R}(\mathcal{W})$  represents a rate allocation that assigns rates to all messages  $W \in \mathcal{W}$ .  $\mathbf{R}(\mathcal{W})$  is said to be achievable if there exists a joint encoding/decoding policy such that the probability of error approaches 0 as  $N$  tends to infinity.

## 2.2 TIM Problem for Wireless Networks

### 2.2.1 DoF Analysis

Remember that in TIM of a wireless network, the corresponding channel coefficients of the weak interference links are zero, while the corresponding channel coefficients of the significant interference links are set to one. This corresponds to a binarization of the wireless network giving a TIM representation of the wireless network as a partially connected wireless network.

The topological interference management problem refers to the study of the DoF of partially connected wireless communication networks with no CSIT beyond the interference topology, i.e., a knowledge of which interference links are weak.

In the partially connected model, the SNR can be artificially increased toward infinity by letting the transmit powers tend to infinity for all sources simultaneously, while keeping the same interference topology. This approach is however not exact and we will discuss it in chapter 4.

The DoF analysis can be seen as the computation of a number of resource units allocated to each transmission, without focusing on the exact SNR, namely

**Definition 1** (DoF analysis). *If there exists a sequence of achievable rate allocations  $\mathbf{R}(\mathcal{W})$ , such that the limit  $R(W)/\log(\text{SNR})$  exists for all  $W \in \mathcal{W}$  as  $\text{SNR} \rightarrow +\infty$ , then these limit values are said to be an achievable DoF allocation:*

$$\text{DoF}(W) = \lim_{\text{SNR} \rightarrow +\infty} \left( \frac{R(W)}{\log(\text{SNR})} \right), \quad \forall W \in \mathcal{W} \quad (2.6)$$

The joint DoF is noted as

$$\mathbf{D}(\mathcal{W}) = [\text{DoF}(W_1), \text{DoF}(W_2), \dots, \text{DoF}(W_K)]^t, \quad (2.7)$$

where  $(\cdot)^t$  denotes the vector transpose operation.

In addition, we can define the DoF region and the symmetric DoF as follows.

**Definition 2** (DoF region). *The closure of the set of achievable DoF allocations is called the DoF region and denoted as  $\mathcal{D}$ .*

**Definition 3** (Symmetric DoF). *The symmetric DoF value,  $\text{DoF}_{sym}$ , is the largest DoF value  $\text{DoF}_0$ , such that the DoF allocation  $\text{DoF}(W) = \text{DoF}_0, \forall W \in \mathcal{W}$ , is inside the DoF region.*

The symmetric DoF is a fair and compact metric to evaluate the performance of different resource allocations.

### 2.2.2 Graph Models for DoF Analysis

To aid in understanding the following graph definitions, from hereon we will base our examples on the partially connected wireless network shown in Fig. 2.3. This partially connected wireless network corresponds to a one possible TIM instance, i.e., TIM representation, of the initial wireless network given in Fig. 2.2(b). This partially connected network is given through a one possible TIM binarization of the initial wireless network, such that the weak interference links are given as,  $\bar{S}_1 = \{S_2 \rightarrow D_1, S_3 \rightarrow D_1\}$ ,  $\bar{S}_2 = \{S_4 \rightarrow D_2, S_5 \rightarrow D_2\}$ ,  $\bar{S}_3 = \{S_1 \rightarrow D_3\}$ ,  $\bar{S}_4 = \{S_1 \rightarrow D_4\}$ , and  $\bar{S}_5 = \{S_1 \rightarrow D_5, S_2 \rightarrow D_5, S_3 \rightarrow D_5\}$ .

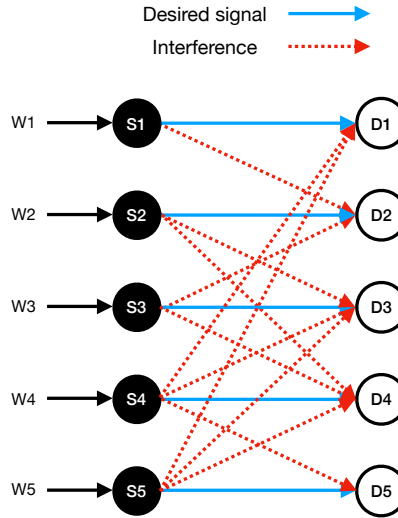

Figure 2.3: TIM instance: partially connected wireless network.

We define the graph representation for the interference topology of TIM in the unicast settings as follows.

**Definition 4** (Interference Topology Graph). *Interference topology graph is an undirected bipartite graph with  $K$  vertices on one side, each vertex representing a unique message source  $S_j$ , and  $K$  vertices on the other side, each vertex representing a unique message destination  $D_i$ . Each message source  $S_j$  wishes to send a unique message  $W_j \in \mathcal{W}$ , while each message destination  $D_i$  desires a unique message  $W_i \in \mathcal{W}$ . Every edge in this graph connects a vertex from the source side to a vertex on the destination side. Two kinds of edges are existing in this graph: edges representing the desired links, and edges representing the significant interference links. All other possible edges, i.e., the edges representing the weak interference links, will be suppressed in this interference graph representation.*

Fig. 2.4 represents the interference topology graph, of the considered TIM instance in our example in Fig. 2.3, associated to 5-unicast TIM problem of the wireless network given in Fig. 2.2(b).

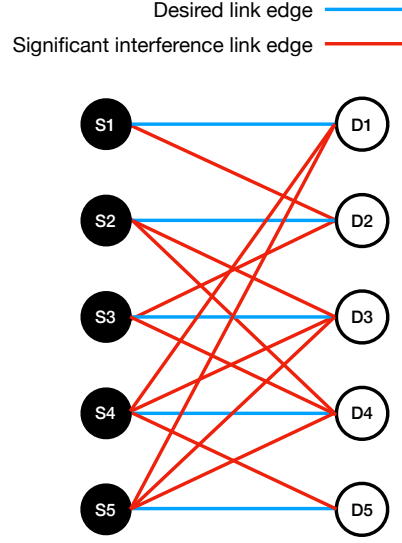

Figure 2.4: Interference topology graph of the TIM instance in Fig. 2.3 associated to 5-unicast TIM problem of the wireless network given in Fig. 2.2(b).

Based on the interference topology graph definition, let us define a few other useful graph representations associated to a TIM instance:

**Definition 5** (Conflict Graph). *The conflict graph is an undirected graph, where each vertex represents a unique message from the set of all messages  $\mathcal{W}$  and an edge between the vertices that representing the messages  $W_i$  and  $W_j$ ,  $i \neq j$ , exists only if either destination  $D_i$  is corrupted by source  $S_j$ , i.e.,  $\{S_j \rightarrow D_i\} \in \mathcal{S}_i$ , or destination  $D_j$  is corrupted by source  $S_i$ , i.e.,  $\{S_i \rightarrow D_j\} \in \mathcal{S}_j$ .*

The conflict graph is the most classical graph representation of an interference network and the edges stand for constraints on resource allocation. Typically, for an orthogonal resource allocation, this problem is a graph coloring problem.

**Definition 6** (Alignment Graph). *The alignment graph is an undirected graph, where each vertex represents a unique message from the set of all messages  $\mathcal{W}$  and an edge between the vertices that representing the messages  $W_i$  and  $W_j$ ,  $i \neq j$ , exists only if there exists a destination  $D_k$ ,  $k \neq i$  and  $k \neq j$ , which is simultaneously corrupted by sources  $S_i$  and  $S_j$ , i.e.,  $\{S_i \rightarrow D_k\} \in \mathcal{S}_k$  and  $\{S_j \rightarrow D_k\} \in \mathcal{S}_k$ .*

The alignment graph is used for interference alignment based non-orthogonal resource allocation, where the objective is to try to group all interference at a RX in a reduced subspace. The alignment graph and the conflict graph for the interference topology of Fig. 2.4 are shown in Fig. 2.5(a) and Fig. 2.5(b) respectively. In this example, the black edge between message nodes  $W_4$  and  $W_5$ , in the alignment graph, comes from the fact that  $\{S_4 \rightarrow D_3\} \in \mathcal{S}_3$  and  $\{S_5 \rightarrow D_3\} \in \mathcal{S}_3$ . (and also  $\{S_4 \rightarrow D_1\} \in \mathcal{S}_1$  and  $\{S_5 \rightarrow D_1\} \in \mathcal{S}_1$ ). Message node  $W_1$  is connected by a red edge to message node  $W_2$ , in the conflict graph, because  $\{S_1 \rightarrow D_2\} \in \mathcal{S}_2$ .

Based on these graphs, two additional definitions follow:

**Definition 7** (Alignment Set). *Each set of messages that correspond to vertices of a connected component of the alignment graph is called an alignment set.*

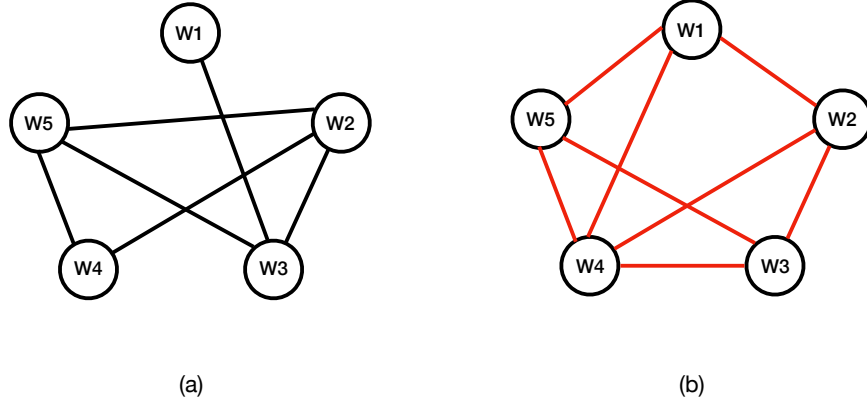

Figure 2.5: (a) Alignment graph and (b) conflict graph for the interference topology of Fig. 2.4.

**Definition 8** (Internal Conflict). *The existence of a conflict edge in the conflict graph between two vertices representing two messages belonging to the same alignment set is called an internal conflict.*

Such definition points out a bottleneck in the resource allocation procedure. Indeed, while the signals associated in an alignment set should be aligned (restricted to the same subspace), the internal conflict calls for the opposite. In Fig. 2.5(a) we have one alignment set  $\{W_1, W_2, W_3, W_4, W_5\}$  and all the conflict edges in Fig. 2.5(b) are internal conflicts. Exploiting the theorems presented in the following sections, we will see that the maximal symmetric DoF of this instance is  $1/3$ .

Let us take another example from the same TIM instance of Fig. 2.3. For instance, let us assume that each BS in Fig. 2.2(a) is able to cancel the interference between its own messages (e.g. thanks to Successive Interference Cancellation (SIC) or beamforming), which means that the significant interference links  $S_2 \rightarrow D_3$ ,  $S_3 \rightarrow D_2$ ,  $S_4 \rightarrow D_5$ , and  $S_5 \rightarrow D_4$ , in Fig. 2.3, become weak interference links in this new model. Fig. 2.6 represents the interference topology graph of this model. The alignment graph and the conflict graph for the interference topology of Fig. 2.6 are shown in Fig. 2.7(a) and Fig. 2.7(b) respectively. In Fig. 2.7(a) we have three alignment sets  $\{W_1\}$ ,  $\{W_2, W_3\}$ ,  $\{W_4, W_5\}$ , and from Fig. 2.7(b) there are no internal conflicts.

In these two examples, the symmetric DoF is  $1/3$  in the first case, and is  $1/2$  in the second case. The theorems used to get these symmetric DoF values will be presented in the next sections. Note that the symmetric DoF of  $1/2$  is not achievable with orthogonal resource sharing.

**Definition 9** (Conflict Distance). *The conflict distance is defined for two vertices, in the alignment graph, representing two messages belonging to the same alignment set and having a conflict edge in the conflict graph between them, as the minimum number of alignment graph edges that need to be traversed to go from one vertex to the other. The minimum conflict distance of all conflict distances in the alignment graph is denoted as  $\Delta$ .*

Another useful graph that can be used in TIM is the demand graph, defined as follows:

**Definition 10** (Demand Graph). *For a  $K$ -unicast TIM problem, the demand graph is a directed bipartite graph with  $K$  vertices on one side, each vertex representing a unique message*

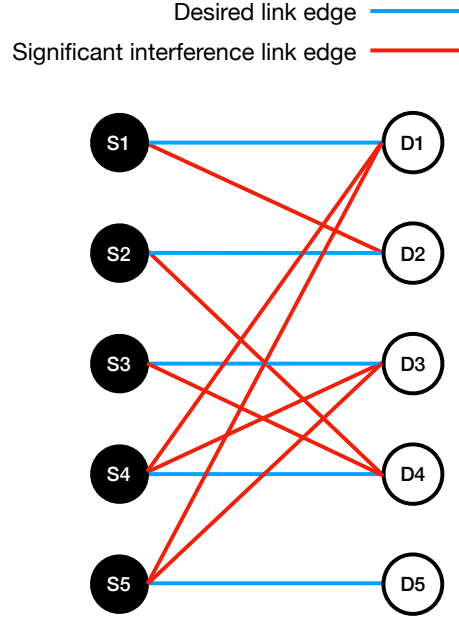

Figure 2.6: Interference topology graph associated to 5-unicast TIM problem of the wireless network given in Fig. 2.2(b), where each BS in Fig. 2.2(a) is able to cancel the interference between its own messages.

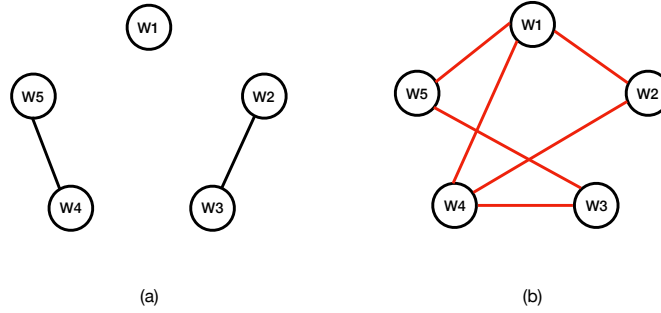

Figure 2.7: (a) Alignment graph and (b) conflict graph for the interference topology of Fig. 2.6.

source  $S_j$ , and  $K$  vertices on the other side, each vertex representing a unique message destination  $D_i$ . Each message source  $S_j$  wishes to send a unique message  $W_j \in \mathcal{W}$ , while each message destination  $D_i$  desires a unique message  $W_i \in \mathcal{W}$ . Two kinds of directed edges are existing in this graph: directed edges, from the source side to the destination side, representing the desired links, i.e., the links  $S_k \rightarrow D_k$ ,  $\forall k \in \{1, 2, \dots, K\}$ , and  $\forall i \in \{1, 2, \dots, K\}$ ,  $\forall j \in \{1, 2, \dots, K\}$ , a directed edge from  $D_i$  to  $S_j$  only when  $\{S_j \rightarrow D_i\} \in \bar{\mathcal{S}}_i$ .

The demand graph for the interference topology of Fig. 2.4 is shown in Fig. 2.8. We may notice that an arrow in the demand graph represents either a transmission from a TX to a RX or an authorization to transmit simultaneously, i.e., a RX indicates to a TX that it does not suffer from its interference.

**Definition 11** (Acyclic Demand Graph [1]). *A demand graph is acyclic if it is not possible to*

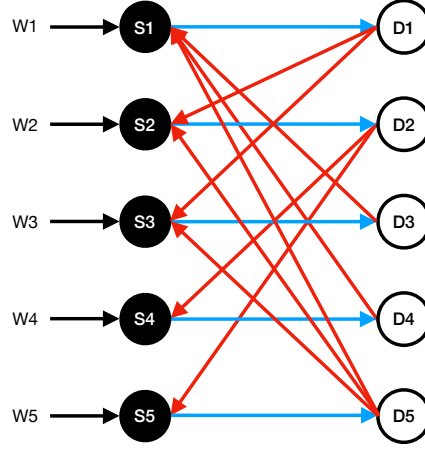

Figure 2.8: The demand graph for the interference topology of Fig. 2.4.

return to any starting point (vertex) while traversing a sequence of directed edges, respecting the direction of the edges.

### 2.2.3 Resource Allocation Strategies

A strict equivalence relationship between the TIM problem and the Index Coding (IC) problem [9, 10], is established in detail in [1], with linear coding. Linear codes are well adapted for TIM. However, there are two important differences in the interpretation.

In TIM problems the linear codes are in  $\mathbb{C}$ , while they are on a finite field for IC problems. Therefore, for IC linear codes, the constraint is to work on a sufficiently large field to be able to generate a sufficient number of pairwise linearly independent vectors. With this constraint fulfilled, we know a solution exists. However, the number of pairwise linearly independent vectors may be infinite in a space of size 2, but the resulting SNR (a notion that does not exist in IC), degrades when the number of vectors increases.

Basically, in IC problems, if a linear coding strategy is found, the exact capacity is known. But in TIM problems, a linear coding using non-orthogonal vectors degrades the Signal to Interference Plus Noise Ratio (SINR) which is guaranteed only if an orthogonal resource allocation is performed.

Therefore, the choice follows: either the resource allocation is restricted to an orthogonal allocation strategy and the target SINR is granted at the price of a limited DoF region, or a linear coding strategy is used allowing to increase the DoF region, at the price of reduced individual SINRs.

#### Linear Coding

Linear coding associated to IC or TIM may be considered as a way to increase the DoF in the analysis. Let us consider a transmission over  $N_t$  time slots. Note that a necessary condition is that all channel gains remain constant over these slots.

**Definition 12** (Linear Coding for TIM). *A linear coding scheme for the TIM problem, is defined by the following elements:*

1. For each message  $W_k \in \mathcal{W}$ ,  $k \in \{1, 2, \dots, K\}$ , define a code-length  $L_k$ , which determines the number of symbols sent simultaneously during the  $N_t$  slots. The input vector for this message is  $\mathbf{X}_k = [x_1(W_k), x_2(W_k), \dots, x_{L_k}(W_k)]^t$ .
2. For each message,  $W_k \in \mathcal{W}$ , define a precoding matrix  $\mathbf{V}_k \in \mathbf{C}^{N_t \times L_k}$ .
3. For each message destination  $D_k$  that desires message  $W_k$ , define a RX combining matrix  $\mathbf{U}_k \in \mathbf{C}^{L_k \times N_t}$ .

These matrices verify the following properties:

- Property 1:  $\det(\mathbf{U}_k \cdot \mathbf{V}_k) \neq 0; \forall k \in \{1, 2, \dots, K\}$ .
- Property 2:  $\mathbf{U}_k \cdot \mathbf{V}_{k'} = 0; \forall k, k' \in \{1, 2, \dots, K\}$  and  $k' \neq k$ .

The first property ensures that RX  $D_k$  will be able to decode the message  $W_k$  from its observation, and the second cancels all interference. Indeed the message  $W_k$  is sent on the channel through  $\mathbf{V}_k \cdot \mathbf{X}_k$ , and  $D_k$  who wants to decode the message  $W_k$  receives

$$\mathbf{Y}_k = h_{kk} \cdot \mathbf{V}_k \cdot \mathbf{X}_k + \left( \sum_{\{S_{k'} \rightarrow D_k\} \in \mathcal{S}_k} h_{kk'} \cdot \mathbf{V}_{k'} \cdot \mathbf{X}_{k'} \right) + \mathbf{Z}_k,$$

and computes

$$\begin{aligned} \tilde{\mathbf{Y}}_k &= \mathbf{U}_k \cdot \mathbf{Y}_k \\ &= h_{kk} \cdot \mathbf{U}_k \cdot \mathbf{V}_k \cdot \mathbf{X}_k + \mathbf{U}_k \cdot \mathbf{Z}_k, \end{aligned} \tag{2.8}$$

where the second line comes from properties 1 and 2. The direct inversion of  $\mathbf{U}_k \cdot \mathbf{V}_k$  provides the zero-forcing receiver.

Some important comments can be drawn:

1. Linear codes maybe not optimal. For instance, it is known that the capacity region of interference channels may be increased by using superposition coding techniques. In the framework of TIM, that would consist in implementing interference cancellation techniques at the RXs to remove potentially high interference. However, to do so, a RX would need to know the values of the interference channels which would require more signaling and more feedback. Therefore, working with linear codes may be sufficient for low feedback mechanisms.
2. With IC, the linear coding is performed on finite fields and the existence of such code relies on the size of the field. For TIM, the coding is performed on complex values, and the size is infinite, and therefore does not suffer from a limit. However, the limit comes from the noise, since solving (2.8) with a zero-forcing may lead to a strong SNR reduction. The noise term in (2.8) doesn't hold in IC problems, but maybe highly significant in TIM problems.
3. The optimization of linear codes relies on finding optimal coding and decoding matrices, including their size and their eigenvectors.



### Interference Alignment Strategy

IA is the most straightforward application of linear coding. IA involves two objectives.

Consider a RX, in a TIM instance, suffering from interference from several TXs, i.e., from TXs where the interference links between these TXs and the RX are significant interference links. If under a linear coding strategy in dimension  $n$ , a scheduler can concentrate the interference of this RX in a subspace  $n'$  as small as possible, then the remaining space of dimension  $n - n'$  is available for interference-free transmissions for this RX. The complementary objective is thus to push the useful signal of this RX in the complementary space of size  $n - n'$ .

The global optimization of an IA strategy, therefore, relies on manipulating alignment and orthogonalization strategies. Such optimization may exploit the conflict graph and the alignment graph. IA as a linear coding strategy for TIM is described in detail in [1].

### Orthogonal Scheduling

The transmission strategy, orthogonal scheduling, is a specific case of linear coding. To have an orthogonal sharing technique, it is sufficient to use only orthogonal vectors in linear coding.

An orthogonal scheduling strategy corresponds to an orthogonal transmission scheme such as Time Division Multiple Access (TDMA) (or any other orthogonal transmission strategy), where time is divided into slots (or channel uses). In each slot, a subset of messages  $\mathcal{W}_o \subset \mathcal{W}$  is scheduled for transmission simultaneously only if these messages are not mutually interfering, i.e., only if there are no conflict edges in the conflict graph between all vertices that are representing the messages in  $\mathcal{W}_o$ . This is necessary to avoid interference. Such an approach is nothing but a classical graph coloring problem on the conflict graph.

To maximize the sum-DoF, it is sufficient to find the largest independent set of vertices in the conflict graph. The size of this set is called the independence number of the conflict graph and it is the maximal sum-DoF. To maximize the symmetric DoF, we need to solve the graph coloring problem with the minimum number of colors. Each color represents a time slot. If a strategy uses  $n_s$  colors, then the DoF per transmitted message is  $1/n_s$ . If each message is allowed to transmit only in one slot, the strategy is a pure orthogonal scheduling scheme. If some messages are allowed to transmit in several slots, the strategy is called a fractional orthogonal scheduling scheme [28]. The example in Fig. 2.9(a) shows the benefits of fractional schemes. In Fig. 2.9(a), a symmetric DoF of  $1/3$  can be achieved by successively serving orthogonal subsets of messages such as  $\{W_1, W_3\}$ ,  $\{W_2, W_4\}$ ,  $\{W_5\}$ , and we can't achieve a symmetric DoF higher than  $1/3$  using pure orthogonal scheduling. However, by fractional orthogonal scheduling:  $\{W_1, W_3\}$ ,  $\{W_3, W_5\}$ ,  $\{W_5, W_2\}$ ,  $\{W_2, W_4\}$ ,  $\{W_4, W_1\}$  (note that each message belongs to two subsets), we can achieve a symmetric DoF of  $2/5$  per message.

## 2.3 Known DoF Results from TIM and IC

IA [3] has been considered as a linear interference management technique achieving the optimal DoFs in many scenarios. But besides its DoF optimality, its practical implementation remains hampered by the costs of obtaining the required CSI [29]. This provided many research efforts to reduce the CSI costs for IA, for example, IA with delayed CSI [30] and alternating CSI [31]. Although these works have been considered to reduce the CSI costs, however, these works did not provide clear results to improve the practical implementation.

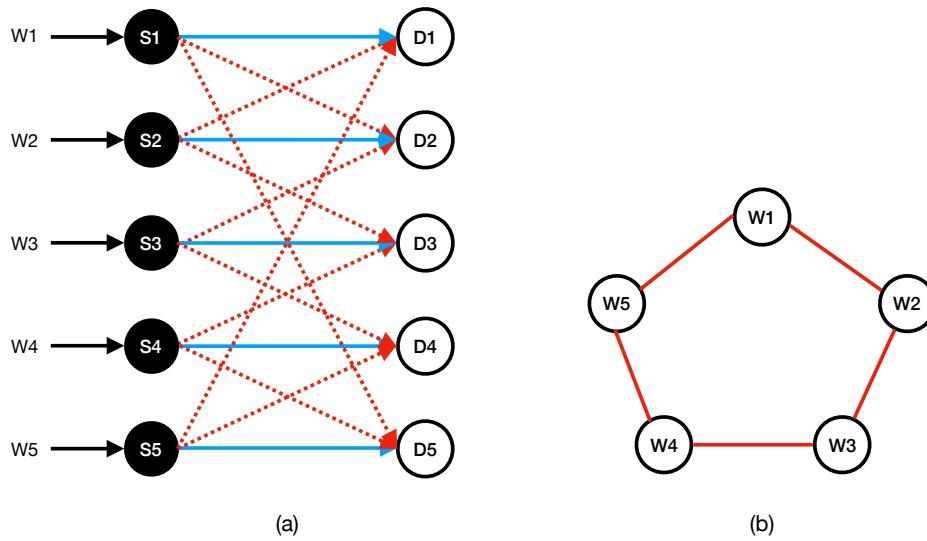

Figure 2.9: (a) Five-unicast TIM problem and (b) its conflict graph [1].

As stated before, TIM [1] has been emerged as a promising tool for interference management in the multi-user interference networks. TIM is an interference management solution where the knowledge of the interference channel information is only about the interference topology of the network. Specifically, the CSI assumption that is associated to TIM is that the CSIT only includes the interference topology information, i.e., the knowledge of which interference channels are weak and which are significant, and there is no CSIT beyond the interference topology information, and the CSIR only includes, besides the interference topology information, the knowledge of the desired channel coefficients at each RX. Based on the practical applicability of the CSI assumption in TIM, the TIM problem has received considerable attention and has been studied in different scenarios, e.g., the fast fading scenarios [32, 33], and TX cooperation [21].

By considering the existing results from IC problems, and based on the relationship, between the TIM problem and the IC problem, that has been considered in [1], Jafar in [1] was presented capacity and DoF analysis for the TIM problem of wireless networks. Since the IC problem is an open problem, then the existing results are only representing some special cases. Thus, in the TIM problem for wireless networks, the optimal DoF solution is still unknown for general interference topologies.

In this section, we summarize the main results obtained from the literature. For a detailed overview of the TIM for wireless networks, the interested readers are referred to [1, 27] and the references therein.

### 2.3.1 Half-DoF-Feasible Networks

The first kind of result concerns a specific family of interference topologies, for which a symmetric DoF of 0.5 per message  $W \in \mathcal{W}$  is achievable. Namely, each message  $W \in \mathcal{W}$  can achieve a DoF value of 0.5, whatever the number of messages  $K$ . The objective is to characterize at which conditions, a network can reach this performance.

**Theorem 1** ([1]). *The necessary and sufficient condition in a TIM problem to achieve symmetric DoF of 0.5 per message  $W \in \mathcal{W}$  is that the corresponding TIM instance has no*

*internal conflict.* (see Def. 8).

A TIM instance is called "*half-DoF-feasible*" if there are no internal conflicts, and "*half-DoF-unfeasible*" otherwise.

If a TIM instance has no internal conflict, then each message  $W \in \mathcal{W}$  can achieve a DoF value of 0.5. This is one of the most favorable situations. The TIM instances who verify this property have the property of half-DoF-feasibility. Jafar [1] further proved that in this situation, for every  $K$ -unicast TIM problem, a fractional orthogonal scheduling scheme can achieve at least the symmetric DoF of 0.25 per message  $W \in \mathcal{W}$ . Therefore, for this class of networks, the best improvement of any complex resource allocation scheme, over fractional orthogonal scheduling schemes is no more than a factor of 2. The price for simplicity (using an orthogonal allocation) is a performance loss of 50%. Jafar further proved that we cannot guarantee a lower price.

### 2.3.2 $1/K$ Optimal Symmetric DoF for $K$ -Unicast TIM Problems

This section considers the case when the maximum achievable DoF per message  $W \in \mathcal{W}$  is no more than the DoF that can be reached with a pure orthogonal scheduling scheme TDMA.

**Theorem 2** ([1]). *The necessary and sufficient condition for a  $K$ -unicast TIM problem to have symmetric DoF of  $1/K$  per message  $W \in \mathcal{W}$  is that its demand graph is acyclic. (see Def. 11).*

When a  $K$ -unicast TIM problem has an acyclic demand graph, then the maximal symmetric DoF per message  $W \in \mathcal{W}$  is  $1/K$ , with no marge for improvement. This corresponds to a very pessimistic case, where the demand graph is rather weakly connected.

Using the property of the acyclic demand graph, Theorem.2 can be relaxed, by considering a subset of messages, to consider the  $K$ -unicast TIM problems where the symmetric DoF is more than  $1/K$ , as shown in the following theorem. First, let us consider the definition of an acyclic subset of messages as follows.

**Definition 13** (Acyclic Subset of Messages[1]). *Consider a  $K$ -unicast TIM problem of the set of messages  $\mathcal{W}$ . A subset of messages  $\mathcal{W}_a \in \mathcal{W}$  is said to be acyclic if and only if the demand graph of the  $|\mathcal{W}_a|$ -unicast TIM problem, that obtained from the  $K$ -unicast TIM problem by eliminating each message  $W \notin \mathcal{W}_a$ , is an acyclic demand graph.*

**Theorem 3** ([34]). *The symmetric DoF of a TIM problem is bounded as follows*

$$\text{DoF}_{sym} \leq \frac{1}{\Psi}, \quad (2.9)$$

where  $\Psi$  is the maximum cardinality of an acyclic subset of messages.

### 2.3.3 Half-DoF-Unfeasible Networks

Due to the property of half-DoF-feasible networks, it is clear that half-DoF-unfeasible networks have internal conflicts. Recall that an internal conflict is an existence of a conflict edge in the conflict graph between two vertices representing two messages belonging to the same alignment set. Using IA strategy, messages in the same alignment set should be aligned as much as possible, but conflicting messages, i.e., messages that have a conflict edge between

their vertices in the conflict graph, cannot be aligned. Then, the following theorem, obtained by Jafar [1], presents an outer bound on the symmetric DoF for half-DoF-unfeasible TIM problems.

**Theorem 4** ([1]). *For half-DoF-unfeasible  $K$ -unicast TIM problems, the symmetric DoF is bounded above as:*

$$\text{DoF}_{\text{sym}} \leq \frac{\Delta}{2\Delta + 1}, \quad (2.10)$$

where  $\Delta$  is the minimum internal conflict distance (see Def.9).

The symmetric DoF for half-DoF-unfeasible TIM problems where each alignment set has either no cycles or no forks has been specified in [1] by the following theorem. First, let us define the cycle and the fork as follows.

**Definition 14** (Cycle [35]). *In a graph, a cycle is a set of vertices and edges that form a closed loop.*

**Definition 15** (Fork [1]). *In a graph, a fork is a vertex that is connected by three or more edges.*

**Theorem 5** ([1]). *A sufficient condition for a half-DoF-unfeasible  $K$ -unicast TIM problem to have a symmetric DoF of  $\min\left(\frac{\Delta}{2\Delta + 1}, \frac{1}{\Psi}\right)$ , where  $\Delta$  is the minimum internal conflict distance and  $\Psi$  is the maximum cardinality of an acyclic subset of messages, is that in the corresponding TIM instance each alignment set has either no cycles or no forks.*

**Remark 1.** *Consider a TIM instance with a constraint such that there are either no cycles or no forks in each alignment set, then this TIM instance is restricted such that there can be no more than three interferers at any RX (i.e., there can be no more than three significant interference links for any RX). The four or more interferers at any RX (i.e., the four or more significant interference links for any RX) will form an alignment graph that will have both cycles and forks.*

The symmetric DoF solution for half-DoF-unfeasible TIM problems, where each RX has no more than two interferers (i.e., there are no more than two significant interference links for any RX), and there are fewer than 6 alignment edges in each alignment set, is presented in the following theorem [36].

**Theorem 6** ([36]). *A sufficient condition for a half-DoF-unfeasible  $K$ -unicast TIM problem to have a symmetric DoF of  $\frac{\Delta}{2\Delta + 1}$ , where  $\Delta$  is the minimum internal conflict distance, is that in the corresponding TIM instance each message destination is interfered by at most two messages (i.e., there are no more than two significant interference links for any message destination) and each alignment set contains fewer than or equal to 6 alignment edges.*

The symmetric DoF for half-DoF-unfeasible TIM problems where each alignment set has either no cycles or no forks, has been characterized in [1]. In [36], the symmetric DoF characterization has been considered for an expanded class of half-DoF-unfeasible TIM problems where alignment sets allowed to contain both cycles and forks.

**Theorem 7** ([36]). *A sufficient condition for a half-DoF-unfeasible  $K$ -unicast TIM problem to have a symmetric DoF of  $\frac{\Delta}{2\Delta+1}$ , where  $\Delta$  is the minimum internal conflict distance, is that in the corresponding TIM instance each message destination is interfered by at most two messages (i.e., there are no more than two significant interference links for any message destination) and each alignment set has no overlapping cycles, i.e., no two cycles share an alignment edge in the alignment graph.*

### 2.3.4 Algorithmic Approaches for TIM Problem

The optimal DoF solution, from the information theoretic perspective, in the TIM problem for wireless networks is still unknown for the general interference topologies, while the existing DoF solutions are only representing some special cases. Thus, for general interference topologies and away from the information theoretic perspective, many algorithmic approaches have been considered to evaluate the achievable DoFs in the TIM problem for wireless networks. These algorithmic approaches aim to maximize the achievable DoFs in the TIM problem using linear interference management schemes.

Based on the low-complexity and the DoF optimality, from the information theoretic perspective, of the linear interference management schemes in many scenarios [1, 3], another formulation for TIM problem has been considered by recasting the original TIM problem as a Low Rank Matrix Completion (LRMC) problem [37]. The LRMC problem is an optimization problem aiming to maximize the achievable DoFs in the TIM problem based on the linear schemes [1]. But, the resulting LRMC problem is NP-hard. Thus, some algorithmic approaches have been proposed to tackle this NP-hard problem [17, 38, 39, 40, 41, 42]. An algorithmic approach has been proposed to solve the TIM problem for wireless networks with symmetric DoFs [17, 39]. The results on the symmetric DoF case for each user [17, 39] have been extended to any achievable DoF region in [40].

### 2.3.5 DoF Optimality of Fractional Coloring in TIM

In this section, we will present the sufficient condition, that has been introduced in [35], for an orthogonal access scheme such as fractional coloring to achieves the DoF region of the TIM problem. Let us first present some key definitions and remarks pertaining to the sufficient condition.

**Definition 16** (Fractional Coloring). *Fractional coloring corresponds to an orthogonal transmission scheme such as TDMA, where time is divided into slots. In each slot, a subset of messages  $\mathcal{W}_o \subset \mathcal{W}$  is scheduled for simultaneous transmission only if these messages are not mutually interfering, i.e., only if there are no conflict edges in the conflict graph between all vertices that are representing the messages in  $\mathcal{W}_o$ .*

**Definition 17** (Long Cycle [35]). *In a graph, a cycle is a set of vertices and edges that form a closed loop. The number of vertices in a cycle represents the length of this cycle. A long cycle is a cycle of length 6 or more.*

**Definition 18** (Chord [35]). *In a graph, the edge that connects two non-adjacent vertices of a cycle is called a chord.*

**Remark 2.** *In a graph, two vertices are adjacent if there is an edge between them.*

**Definition 19** (Chordal Bipartite Network [35]). *A TIM instance is chordal bipartite if each long cycle in the interference topology graph of the TIM instance contains at least one chord.*

**Remark 3** ([35]). *The interference topology graph cannot contain odd-length cycles because it is a bipartite graph. The interference topology graph cannot contain length-2 cycles because it is a simple graph, i.e., there are no multiple edges. A length-4 cycle in the interference topology graph cannot contain a chord because in the interference topology graph the vertices that are representing the message sources can never be connected by edges and the vertices that are representing the message destinations can never be connected by edges.*

**Definition 20** (Set of Cliques of Conflict Graph ( $\mathcal{Q}$ ) [35]). *A set of vertices, in the conflict graph, such that any two vertices in this set are adjacent is called a clique  $Q$  of the conflict graph. We denote by  $\mathcal{Q}$  to the set of all cliques of the conflict graph.*

The following theorem presents the sufficient condition, that has been introduced in [35], for fractional coloring to achieves the DoF region of the TIM problem.

**Theorem 8** ([35]). *Fractional coloring achieves the DoF region of a TIM problem if the TIM instance is chordal bipartite. For chordal bipartite TIM instance, the DoF region of the TIM problem is characterized through the conflict graph, as follows:*

$$\forall Q \in \mathcal{Q}, \sum_{v_W \in Q} \text{DoF}(W) \leq 1, \quad (2.11)$$

where  $v_W$  is a vertex in the conflict graph representing a message  $W \in \mathcal{W}$ ,  $Q$  is a clique of the conflict graph, and  $\mathcal{Q}$  is the set of all cliques of the conflict graph.

## 2.4 Achievable Rates under TIM

Consider any possible  $K$ -unicast TIM instance of the initial wireless network as introduced in Section 2.1. Based on graph analysis, we can determine some achievable joint DoF allocation  $\mathbf{D}(\mathcal{W})$  inside the DoF region  $\mathcal{D}$  of the TIM problem, where the achievable joint DoF allocation  $\mathbf{D}(\mathcal{W})$  is noted as

$$\mathbf{D}(\mathcal{W}) = [\text{DoF}(W_1), \text{DoF}(W_2), \dots, \text{DoF}(W_K)]^t, \quad (2.12)$$

and  $\text{DoF}(W_k)$ ,  $k \in \{1, 2, \dots, K\}$ , is an achievable DoF allocation, per message  $W_k$ , inside the DoF region  $\mathcal{D}$  of the TIM problem. However, depending on the used resource allocation scheme, the achievable rates can be evaluated.

In the case of an orthogonal resource allocation, each RX is granted to get no interference from the significant interference sources (i.e., message sources that have significant interference links with the RX) identified in the considered TIM instance. Then, for this TIM instance, the collective interference at RX  $D_i$ ,  $\forall i \in \{1, 2, \dots, K\}$ , from the weak interference links in  $\bar{\mathcal{S}}_i$ , is upper bounded by  $N_0$  as in (2.5), and the orthogonal resource allocation process will guarantee a lower bound on the effective SINR at each RX  $D_i$ , given as

$$\xi_i \geq \frac{\gamma}{2}, \quad \forall i \in \{1, 2, \dots, K\}. \quad (2.13)$$

In this case, if an achievable joint DoF allocation  $\mathbf{D}(\mathcal{W})$ , through an orthogonal resource allocation, is feasible inside the DoF region  $\mathcal{D}$ , then a vector of achievable rates  $\mathbf{R}$  exists, such

that

$$\mathbf{R} = \mathbf{D}(\mathcal{W}) \cdot \log_2 \left( 1 + \frac{\gamma}{2} \right). \quad (2.14)$$

According to [1], linear coding allows to increase the DoF by using non-orthogonal linear vectors, but in turns result in a degraded SINR due to the non-orthogonal linear coding penalty factor. This penalty comes from the fact that the receiver has to project the received signal in the interference-free subspace [3]. Therefore, in the general case, when linear coding resource allocation is used, a non-orthogonality penalty factor will come in the expression (2.13), and thus the linear coding resource allocation process will guarantee a lower bound on the effective SINR at each RX  $D_i$ , given as

$$\xi_i \geq \alpha \cdot \frac{\gamma}{2}, \quad \forall i \in \{1, 2, \dots, K\}, \quad (2.15)$$

where  $\alpha$  is the non-orthogonal linear coding penalty factor. Typically,  $\alpha = 1$  when an orthogonal resource allocation is used, while  $0 < \alpha < 1$  when non-orthogonal linear coding is used [1].

Therefore, in the general case, when linear coding resource allocation is used, we can characterize an achievable rate region for the TIM problem, as follows

$$\mathcal{R} \supset \bigcup_{\mathbf{D}(\mathcal{W}) \in \mathcal{D}} \left[ \mathbf{D}(\mathcal{W}) \cdot \log_2 \left( 1 + \alpha_{\mathbf{D}(\mathcal{W})} \cdot \frac{\gamma}{2} \right) \right], \quad (2.16)$$

where the joint DoF  $\mathbf{D}(\mathcal{W})$  is an achievable DoF allocation inside the DoF region  $\mathcal{D}$  of the TIM problem, and  $\alpha_{\mathbf{D}(\mathcal{W})}$  is the loss factor imposed by non-orthogonal transmission schemes that leads to the achievable DoF solution  $\mathbf{D}(\mathcal{W})$  in the TIM problem. Typically,  $\alpha_{\mathbf{D}(\mathcal{W})} = 1$  when an orthogonal resource allocation is used, while  $0 < \alpha_{\mathbf{D}(\mathcal{W})} < 1$  when non-orthogonal linear coding is used [1].

For a TIM problem, we can characterize an achievable symmetric rate per message, i.e., a rate  $R_{sym}$  that can be achieved by each message  $W_k \in \mathcal{W}$  through linear coding, as follows

$$R_{sym} = \text{DoF}_{sym} \cdot \log_2 \left( 1 + \alpha \cdot \frac{\gamma}{2} \right), \quad (2.17)$$

where  $\text{DoF}_{sym}$  is the symmetric DoF per message, i.e., the maximal DoF that can be achieved by each message  $W_k \in \mathcal{W}$  in the TIM problem through linear coding, and  $\alpha$  is the non-orthogonal linear coding penalty factor that leads to the symmetric DoF solution  $\text{DoF}_{sym}$  in the TIM problem.

## 2.5 Conclusion

This chapter reviewed the TIM for wireless networks as introduced in [1]. This chapter introduced the required background for this thesis on the TIM problem for wireless networks. An achievability analysis in terms of information transmission rates for wireless networks, when TIM as considered in [1] is used, is also introduced in this chapter. The remainder of this thesis is divided as follows. Chapter 3 considers the TIM problem for downlink cellular networks. In this chapter, we present the TIM problem for infinite downlink cellular networks when the mobile users are considered to be located at the boundaries between the adjacent cells where the interference is the most severe. Also in this chapter, we present the TIM

problem for the infinite 1D (linear) and the infinite 2D (hexagonal) downlink cellular networks when a continuous uniform distribution of mobile users is adopted. Chapter 4 presents a new approach to construct an interference topology for the unicast TIM problem of multi-user wireless networks. Based on this interference topology construction approach, we are able to evaluate the achievable rate's theoretical limit, in the asymptotic SNR regime, for the underlying wireless network and not just for its topological interference representation. This new approach allows us to cope with the finite SNR regime and not just with the asymptotic SNR regime with the DoF analysis. In this chapter, we evaluate the achievable symmetric rates of the wireless network in both the finite SNR regime and the asymptotic SNR regime. Chapter 5 considers a case study on TIM for small-scale wireless networks, in which in this chapter we apply the proposed achievable rates analysis in chapter 4 for all interference topologies with half-DoF-feasibility in the TIM problem of four users wireless network. Finally, chapter 6 concludes this thesis.





# — 3 —

---

## TIM for Cellular Networks

The analysis of cellular networks through TIM has been the subject of recent works. TIM itself as a technique has been introduced in [1], where the foundations of graph analysis for topological networks have been laid out. TIM analysis for simple cellular network structures (linear, square, and hexagonal), with mobile users located in the border of the cells, and with interference topology such that the significant interference is considered to be only the interference from the base station in the closest immediately adjacent cell, has been addressed in [1]. In this chapter, we consider the TIM analysis for linear cellular networks, with mobile users located in the border of the cells, and with multi-layer interference topology such that the significant interference can be considered from base stations in cells beyond the immediately adjacent cells. The TIM analysis for hexagonal cellular networks in [1] has been extended in [16] by considering asymmetrical mobile user positioning along the border of the cell. The work in [12] shows that, in TIM, an orthogonal resource allocation scheme achieves the sum-DoF for linear (i.e., 1D) convex cellular networks. This work has been later generalized in [13], where 1D and 2D cellular networks have been studied through TIM, in which it has been shown that, if the resulting TIM cellular network is chordal bipartite, then an orthogonal resource sharing scheme based on fractional coloring is sufficient to achieve optimal DoF performance. This work also has been shown that 1D convex cellular networks are chordal bipartite.

Defining an interference topology is crucial to perform TIM analysis. However, different interference thresholds yield different interference topologies. As a matter of fact, even at a given interference threshold, different classifications of interference links may be considered, changing the interference topology accordingly. In this chapter, we will focus on defining a unique interference topology for a wireless network at a given interference threshold. As such the contributions of this chapter are as follows. First, unlike [1, 16, 12, 13], where a discrete distribution of mobile users has been considered, we adopt a continuous uniform distribution of mobile users, where mobile users that share the same interference profile can be grouped into a *user class*. We then apply TIM at the user class level to extract DoF

information for the system independent of the actual mobile user position. This approach is useful to characterize the average performance of the network. Second, we consider the effect of the interference threshold on the interference topology and the DoF of the system. By varying the interference threshold, an interesting trade-off arises: either we have a loosely connected interference topology, hence more DoF, but at the same time a higher interference since mobile users contend more to access the medium, or a densely connected interference topology, hence less DoF, but at the same time a lower interference since mobile users will choose more conservative access to the medium. In this chapter, we look for the best operating point in terms of interference threshold.

This chapter considers the TIM problem for downlink cellular networks. In section 3.1, we present the TIM problem for infinite downlink cellular networks, considered in [1], in which mobile users are considered to be located at the boundaries between the adjacent cells where the interference is the most severe, and only interference from the base station in the closest immediately adjacent cell is considered to be significant interference. In section 3.2, we extend the infinite 1D (linear) downlink cellular network model in section 3.1, by considering multi-layer interference topology where the significant interference can be considered from base stations in cells beyond the immediately adjacent cells. Then, we present the TIM problem for the infinite 1D (linear) downlink cellular networks with multi-layer interference topology. Section 3.3 and section 3.4 present the TIM problem for the infinite 1D (linear) and the infinite 2D (hexagonal) downlink cellular networks, respectively, when a continuous uniform distribution of mobile users is adopted. In these two sections, for the 1D and the 2D downlink cellular networks, the different interference topologies and their link to the interference threshold parameter are presented, and we provide the corresponding DoF analysis and SIR analysis as well as the results of DoF-SIR tradeoff study.

## 3.1 Single-Layer Interference Topology

This section considers the TIM problem for two downlink cellular network models: infinite 1D (linear) and infinite 2D (hexagonal) models, as introduced in [1], with mobile users located in the border of the cells, and with single-layer interference topology, i.e., with an interference topology such that the significant interference is considered to be only the interference from the base station in the closest immediately adjacent cell.

### 3.1.1 Linear Cellular Network

This section presents the TIM problem for infinite 1D (linear) downlink cellular network, as introduced in [1]. The infinite 1D (linear) cellular network model, is considered as in [1] and shown in Fig. 3.1, and it is formed as an infinite linear cellular array such that the cells are placed uniformly along a straight line and are locally connected. The mobile users are considered to be located at the boundaries between the adjacent cells where the interference is the most severe. The TIM problem is considered with single-layer interference topology, i.e., with an interference topology such that the significant interference is considered to be only the interference from the base station in the closest immediately adjacent cell. As shown in Fig. 3.1, each cell has a single base station located at the center of the cell. In this linear cellular model, each cell has two adjacent cells, and each cell shares its boundaries with its adjacent cells. Two mobile users are considered in each cell, such that one mobile user is located at each cell boundary. Each base station is connected to the mobile users only in its

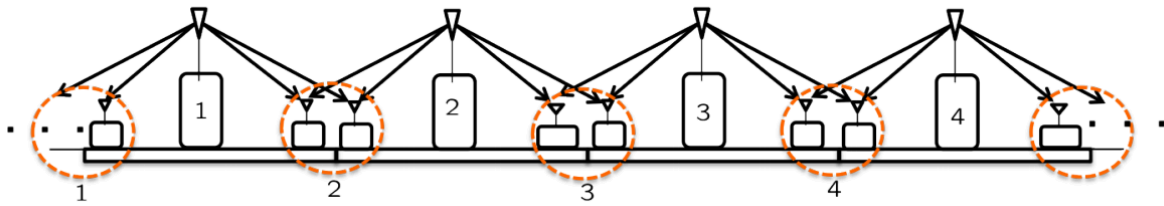

Figure 3.1: Infinite 1D (linear) downlink cellular network [1].

own cell by desired transmission links, i.e., each base station transmits a unique message to every mobile user located in its own cell at the cell boundaries, and single-layer interference topology is considered, i.e., each base station is connected by significant interference links to the mobile users only in the immediately adjacent cells that are located at its cell boundaries.

A conventional frequency reuse scheme, shown in Fig. 3.2(a), is used as an orthogonal sharing TIM scheme for the TIM problem of the infinite 1D (linear) downlink cellular network shown in Fig. 3.1. The conventional frequency reuse scheme in Fig. 3.2(a) shows that different spectral bands (referred by two different colors: white and grey) are assigned to cells that share a common cell edge. Thus, using the conventional frequency reuse scheme, each cell achieves  $1/2$  DoF (i.e.,  $1/4$  DoF per mobile user) and all significant interference is eliminated.

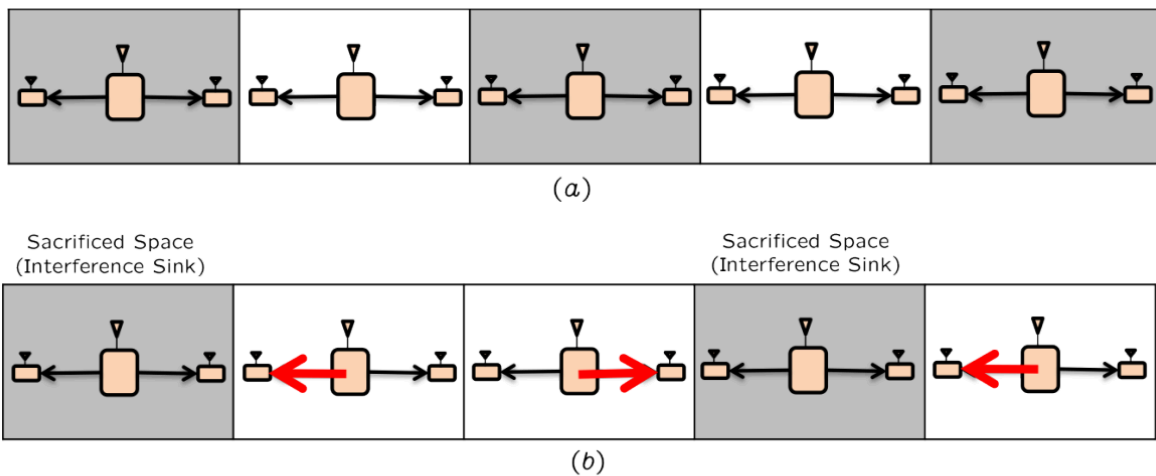

Figure 3.2: Infinite linear cellular model. (a) Conventional frequency reuse [1]. (b) Aligned frequency reuse [1]. The red arrows indicate the choice of the mobile user to be served within each active cell. The remaining mobile users are turned off.

Another orthogonal sharing scheme called aligned frequency reuse, proposed in [1] and illustrated in Fig. 3.2(b), is used as an orthogonal sharing TIM scheme for the TIM problem of the infinite 1D (linear) downlink cellular network shown in Fig. 3.1. The aligned frequency reuse scheme illustrated in Fig. 3.2(b), is considered by repeating a periodic reuse pattern with period 3 cells along the infinite array of linear cells, and such that every third cell (referred by grey colored cells in Fig. 3.2(b)) is sacrificed, i.e., its base station is switched off.

The boundaries of each sacrificed cell are interference-free, i.e., free from significant interference, because its base station is switched off. Therefore, the mobile users of the neighboring

cells of the sacrificed cell that are located on the boundaries of the sacrificed cell can be served by their base stations with no significant interference from the base station of the sacrificed cell. Then, the aligned frequency reuse scheme illustrated in Fig. 3.2(b), is considered by turning on only the mobile users of the active cells that are located on the boundaries of the sacrificed cells (these mobile users are indicated by red arrows in Fig. 3.2(b)).

In order to symmetrize the DoF throughput per cell and per mobile user, the periodic reuse pattern is shifted such that each cell becomes the sacrificed cell (i.e., the cell that their boundaries are interference-free) for  $1/3$  of the time. Thus, using this aligned frequency reuse scheme, each cell achieves  $2/3$  DoF (i.e.,  $1/3$  DoF per mobile user) and all significant interference is eliminated. Therefore, the DoF using the aligned frequency reuse scheme corresponds to an improvement of 33% over the DoF using the conventional frequency reuse scheme.

This orthogonal solution, the  $2/3$  DoF per cell using the aligned frequency reuse scheme, is DoF optimal solution [1]. The argument of this DoF optimality solution has been shown in [1] as follows. Consider any mobile user in any cell, in the linear cellular model in Fig. 3.1, located at the boundary with an adjacent cell. Then, this mobile user can resolve its desired message from its base station (the desired message is decodable by design) and also the two undesired messages from the base station of the adjacent cell that shares its boundary with the cell of the considered mobile user. This is because by eliminating all other messages (eliminating other messages cannot hurt the rates of the remaining messages), the mobile user can reconstruct and subtract its desired message from its received signal, and then the mobile user has an invertible channel to the base station of the two undesired messages in the adjacent cell, which allows the mobile user to resolve these two undesired messages. Thus, one mobile user, with only one antenna, is able to resolve 3 messages. Then, the DoF per message, i.e., per mobile user, cannot be more than  $1/3$ . Therefore, the DoF per cell cannot be more than  $2/3$ . Thus, the orthogonal solution, i.e., the  $2/3$  DoF per cell using the aligned frequency reuse scheme, is DoF optimal solution.

### 3.1.2 Hexagonal Cellular Network

This section presents the TIM problem for infinite 2D (hexagonal) downlink cellular network, as introduced in [1]. The infinite 2D (hexagonal) cellular network model, is considered as in [1] and shown in Fig. 3.3, and it is formed as an infinite hexagonal cellular array such that the cells are placed uniformly in a hexagonal grid pattern and are locally connected. The mobile users are considered to be located at the boundaries between the adjacent cells where the interference is the most severe. The TIM problem is considered with single-layer interference topology, i.e., with an interference topology such that the significant interference is considered to be only the interference from the base station in the closest immediately adjacent cell. As shown in Fig. 3.3, each cell has a single base station located at the center of the cell. In this hexagonal cellular model, each cell has six adjacent cells, and each cell shares its boundaries with its adjacent cells. Six mobile users are considered in each cell, such that one mobile user is located at each cell boundary. Each base station is connected to the mobile users only in its own cell by desired transmission links, i.e., each base station transmits a unique message to every mobile user located in its own cell at the cell boundaries, and single-layer interference topology is considered, i.e., each base station is connected by significant interference links to the mobile users only in the immediately adjacent cells that are located at its cell boundaries.

A conventional frequency reuse scheme, shown in Fig. 3.4(a), is used as an orthogonal

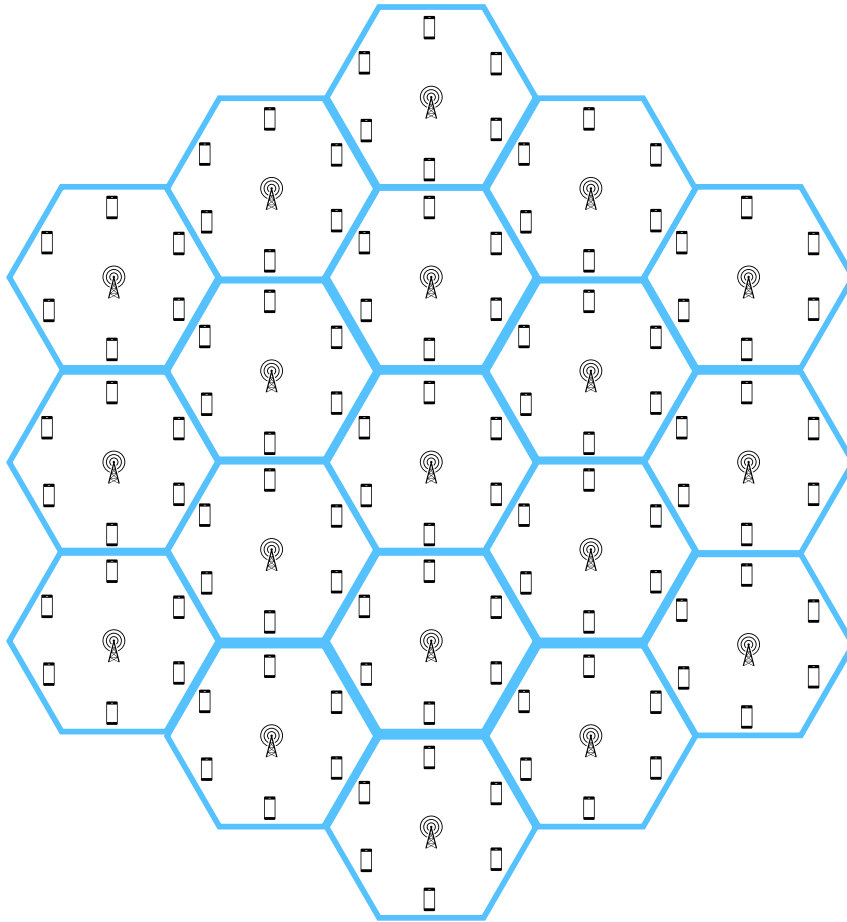

Figure 3.3: Infinite 2D (hexagonal) downlink cellular network.

sharing TIM scheme for the TIM problem of the infinite 2D (hexagonal) downlink cellular network shown in Fig. 3.3. The conventional frequency reuse scheme in Fig. 3.4(a) shows that different spectral bands (referred by three different colors: green, blue, and orange) are assigned to cells that share a common cell edge. Thus, using the conventional frequency reuse scheme, each cell achieves  $1/3$  DoF (i.e.,  $1/18$  DoF per mobile user) and all significant interference is eliminated.

Another orthogonal sharing scheme called aligned frequency reuse, proposed in [1] and illustrated in Fig. 3.4(b), is used as an orthogonal sharing TIM scheme for the TIM problem of the infinite 2D (hexagonal) downlink cellular network shown in Fig. 3.3. The aligned frequency reuse scheme illustrated in Fig. 3.4(b), is considered by repeating a periodic reuse pattern with period 7 cells along the infinite array of hexagonal cells, and such that the center cell within each cluster of 7 cells (referred by grey colored cells in Fig. 3.4(b)) is sacrificed, i.e., its base station is switched off.

The boundaries of each sacrificed cell are interference-free, i.e., free from significant interference, because its base station is switched off. Therefore, the mobile users of the neighboring cells of the sacrificed cell that are located on the boundaries of the sacrificed cell can be served

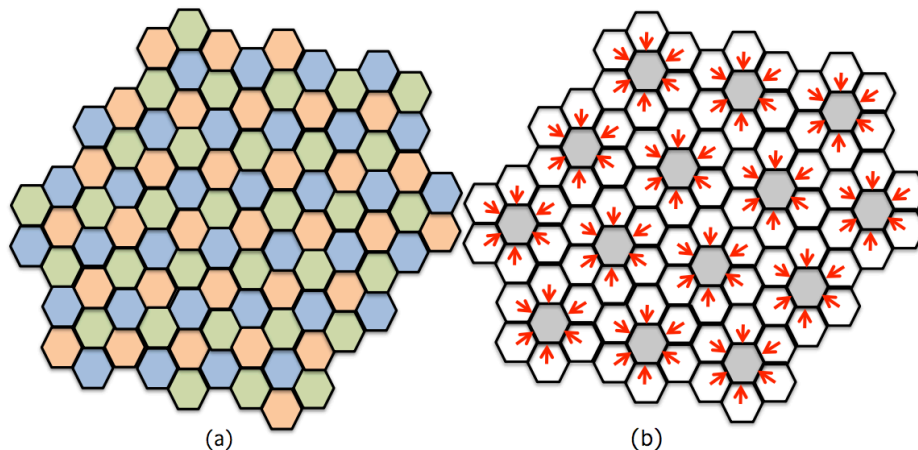

Figure 3.4: Infinite hexagonal cellular model. (a) Conventional frequency reuse [1]. (b) Aligned frequency reuse [1]. The red arrows indicate the choice of the mobile user to be served within each active cell. The remaining mobile users are turned off.

by their base stations with no significant interference from the base station of the sacrificed cell. Then, the aligned frequency reuse scheme illustrated in Fig. 3.4(b), is considered by turning on only the mobile users of the active cells that are located on the boundaries of the sacrificed cells (these mobile users are indicated by red arrows in Fig. 3.4(b)).

In order to symmetrize the DoF throughput per cell and per mobile user, the periodic reuse pattern is shifted such that each cell becomes the sacrificed cell (i.e., the cell that their boundaries are interference-free) for  $1/7$  of the time. Thus, using this aligned frequency reuse scheme, each cell achieves  $6/7$  DoF (i.e.,  $1/7$  DoF per mobile user) and all significant interference is eliminated. Therefore, the DoF using the aligned frequency reuse scheme corresponds to an improvement of 157% over the DoF using the conventional frequency reuse scheme.

This orthogonal solution, the  $6/7$  DoF per cell using the aligned frequency reuse scheme, is DoF optimal solution [1]. The argument of this DoF optimality solution has been shown in [1] as follows. Consider any mobile user in any cell, in the hexagonal cellular model in Fig. 3.3, located at the boundary with an adjacent cell. Then, this mobile user can resolve its desired message from its base station (the desired message is decodable by design) and also the six undesired messages from the base station of the adjacent cell that shares its boundary with the cell of the considered mobile user. This is because by eliminating all other messages (eliminating other messages cannot hurt the rates of the remaining messages), the mobile user can reconstruct and subtract its desired message from its received signal, and then the mobile user has an invertible channel to the base station of the six undesired messages in the adjacent cell, which allows the mobile user to resolve these six undesired messages. Thus, one mobile user, with only one antenna, is able to resolve 7 messages. Then, the DoF per message, i.e., per mobile user, cannot be more than  $1/7$ . Therefore, the DoF per cell cannot be more than  $6/7$ . Thus, the orthogonal solution, i.e., the  $6/7$  DoF per cell using the aligned frequency reuse scheme, is DoF optimal solution.

## 3.2 Multi-Layer Interference Topology

The TIM problem for infinite 1D (linear) downlink cellular network in section 3.1.1, is considered with a simple interference topology model, i.e., the single-layer interference topology, in which the significant interference is considered to be only the interference from the base station in the closest immediately adjacent cell. In this section, we extend the interference topology model in section 3.1.1 for infinite 1D (linear) downlink cellular networks, by considering multi-layer interference topology where the significant interference can be considered from base stations in cells beyond the immediately adjacent cells. Then, we present the TIM problem for the infinite 1D (linear) downlink cellular networks with the multi-layer interference topology. This section presents an optimal DoF outer bound, i.e., a general information-theoretic DoF outer bound, and the aligned frequency reuse DoF solution for the infinite 1D (linear) downlink cellular networks with the multi-layer interference topology.

### 3.2.1 Network Model and Interference Topology

We consider an infinite 1D (linear) cellular network model, formed as an infinite linear cellular array such that the cells are placed uniformly along a straight line and are locally connected. Each cell has a coverage region of length  $L$ . Each cell has a single base station located at the center of the cell. In this linear cellular model, each cell has two adjacent cells, and each cell shares its boundaries with its adjacent cells. Two mobile users are considered to be located in each cell, such that one mobile user is located at each cell boundary. We assume that all mobile users in this model are located exactly at the cell edges. Each base station is connected to the mobile users only in its own cell by desired transmission links, i.e., each base station transmits a unique message to every mobile user located in its own cell at the cell edges.

The TIM problem is considered with multi-layer interference topology, i.e., with an interference topology such that the significant interference can be considered from base stations in cells beyond the immediately adjacent cells. In the TIM problem for the infinite 1D (linear) downlink cellular networks with the multi-layer interference topology, the  $\lambda$ th-layer interference topology, where  $\lambda$  is the maximal number of cells that can be between a base station and a mobile user such that the base station is connected to the mobile user by a significant interference link in the interference topology, is defined by the corresponding interference distance  $D_\lambda$ , such that each base station is connected by significant interference links only to the mobile users located at a distance  $D_\lambda$  or less from the base station. The relationship between the  $\lambda$ th-layer interference topology and the corresponding interference distance  $D_\lambda$  is illustrated in Fig. 3.5.

### 3.2.2 TIM problem: DoF Solution

#### Conventional Frequency Reuse

**Theorem 9.** *The DoF per cell solution using the conventional frequency reuse scheme (orthogonal sharing TIM scheme) in the TIM problem for the infinite 1D (linear) downlink cellular networks with  $\lambda$ th-layer interference topology, is*

$$\text{DoF}_{cell} = \frac{1}{\lambda + 2}, \quad (3.1)$$

where  $\text{DoF}_{cell}$  is the DoF per cell and  $\lambda \in \mathbb{N}$ .



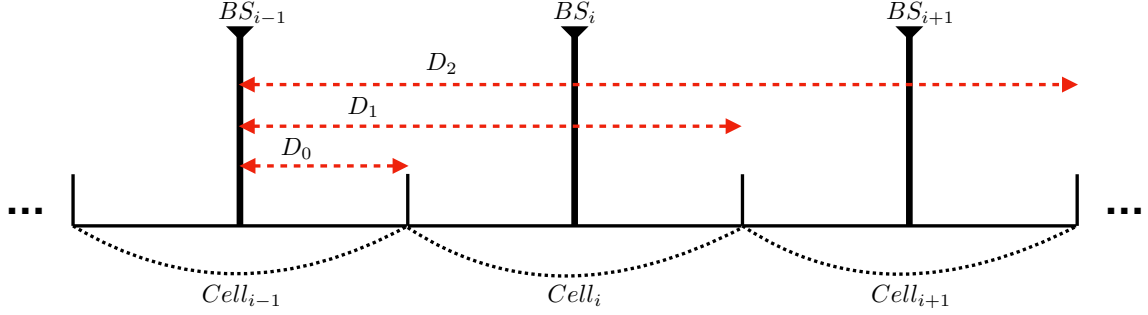

Figure 3.5: Multi-layer interference topology for infinite 1D (linear) cellular network.

*Proof.* A conventional frequency reuse scheme (used as an orthogonal sharing TIM scheme), for the TIM problem of the infinite 1D (linear) downlink cellular network with the  $\lambda$ th-layer interference topology defined in section 3.2.1, can always achieve a  $\frac{1}{\lambda + 2}$  DoF per cell by assigning  $\lambda + 2$  different spectral bands, in a repeated sequence, along the infinite array of linear cells.  $\square$

The DoF per cell solution using the conventional frequency reuse scheme, in section 3.1.1, coincide with  $\lambda = 0$  case, i.e., the zeroth-layer interference topology case where the significant interference is considered to be the interference only from the base station of the closest immediately adjacent cell.

### DoF Outer Bound

The following theorem presents the DoF outer bound of the TIM problem for the infinite 1D (linear) downlink cellular networks with  $\lambda$ th-layer interference topology.

**Theorem 10.** *For the TIM problem of infinite 1D (linear) downlink cellular networks with  $\lambda$ th-layer interference topology, the information-theoretic DoF outer bound is*

$$\text{DoF}_{\text{cell}} \leq \frac{2}{2\lambda + 3}, \quad (3.2)$$

where  $\text{DoF}_{\text{cell}}$  is the DoF per cell and  $\lambda \in \mathbb{N}$ .

*Proof.* The TIM instance, in section 3.2.1, considered with the  $\lambda$ th-layer interference topology, in Fig. 3.5, is convex in the sense defined in [43]. TIM instances of one-dimensional convex cellular networks are always chordal bipartite [35]. Thus, the TIM instance, in section 3.2.1, is chordal bipartite.

In what follows, we present the proof for the considered  $\lambda$ th-layer interference topology in Fig. 3.5, when  $\lambda = 1$ . (The proof can be generalized for any  $\lambda \in \mathbb{N}$ ).

Let us present the conflict graph, of the considered  $\lambda$ th-layer interference topology in Fig. 3.5, when  $\lambda = 1$ . The conflict graph is shown in Fig. 3.6, where  $U_{i,-1}$  denotes the mobile user located in cell  $i$  and at a distance  $L/2$  from  $BS_{i-1}$ ,  $U_{i,+1}$  denotes the mobile user located in cell  $i$  and at a distance  $L/2$  from  $BS_{i+1}$ , and  $L$  is the coverage region length of any cell  $i$ .

For chordal bipartite TIM instances, the DoF region of the TIM problem is characterized through the cliques of the conflict graph as presented in Theorem 8. Based on this and using

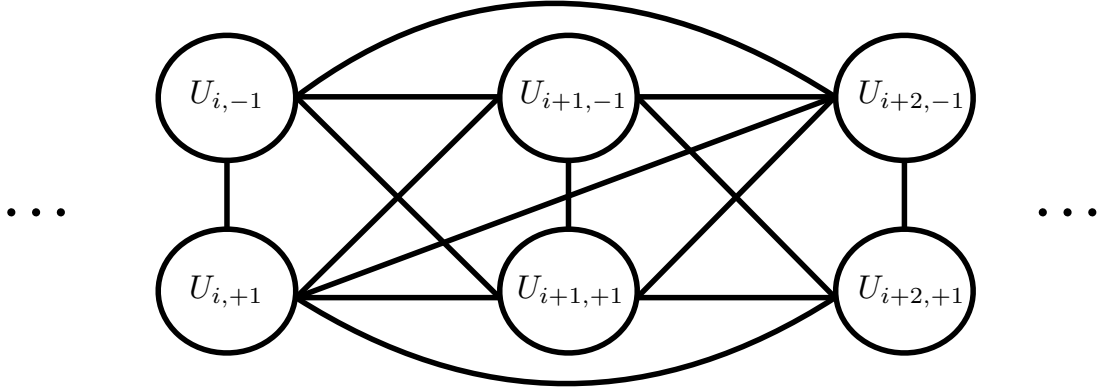

Figure 3.6: The conflict graph of the  $\lambda$ th-layer interference topology in Fig. 3.5 when  $\lambda = 1$ .

the conflict graph shown in Fig. 3.6, the DoF region  $\mathcal{D}$  of the TIM problem is characterized by all the DoF solutions that satisfy

$$\begin{cases} d_{i,-1} + d_{i,+1} + d_{i+1,-1} + d_{i+1,+1} + d_{i+2,-1} \leq 1, & \forall i \\ d_{i,+1} + d_{i+1,-1} + d_{i+1,+1} + d_{i+2,-1} + d_{i+2,+1} \leq 1, & \forall i, \end{cases} \quad (3.3)$$

where  $d_{i,-1}$  and  $d_{i,+1}$  are the DoF of mobile user  $U_{i,-1}$  and  $U_{i,+1}$  respectively.

Since we are targeting the optimal achievable symmetric DoF per mobile user, we can consider that all mobile users achieve the same DoF value  $d$ . Thus, we get an outer bound for the symmetric DoF per mobile user from (3.3) as follows.

$$d \leq \frac{1}{5}. \quad (3.4)$$

Since each cell has two mobile users, this gives us an outer bound of  $2/5$  DoF per cell.  $\square$

### 3.2.3 Aligned Frequency Reuse

Since the TIM instance, in section 3.2.1, considered with the  $\lambda$ th-layer interference topology, in Fig. 3.5, is chordal bipartite, then an orthogonal sharing TIM scheme can achieve the optimal DoF solution as shown in Theorem 8. In this section, we present an orthogonal sharing TIM scheme called aligned frequency reuse for the TIM problem of the infinite 1D (linear) downlink cellular network defined, in section 3.2.1, with the  $\lambda$ th-layer interference topology, in Fig. 3.5, when  $\lambda = 1$ .

The aligned frequency reuse scheme, when  $\lambda = 1$ , illustrated in Fig. 3.7, is considered by repeating a periodic reuse pattern with a period of 5 cells along the infinite array of linear cells, and such that the grey colored cells in Fig. 3.7 are sacrificed, i.e., their base stations are switched off.

The boundaries of each sacrificed cell are interference-free, i.e., free from significant interference, because its base station is switched off. Therefore, the mobile users of the neighboring cells of the sacrificed cell that are located on the boundaries of the sacrificed cell can be served by their base stations with no significant interference from the base station of the sacrificed

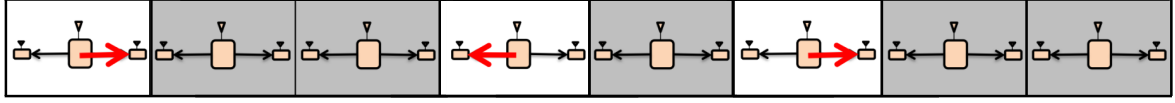

Figure 3.7: Aligned frequency reuse, when  $\lambda = 1$ . The red arrows indicate the choice of the mobile user to be served within each active cell. The remaining mobile users are turned off.

cell. Then, the aligned frequency reuse scheme illustrated in Fig. 3.7, is considered by turning on only the mobile users of the active cells that are located on the boundaries of the sacrificed cells (these mobile users are indicated by red arrows in Fig. 3.7).

In order to symmetrize the DoF throughput per cell and per mobile user, the periodic reuse pattern is shifted such that each cell becomes the sacrificed cell (i.e., the cell that their boundaries are interference-free) for  $1/5$  of the time. Thus, using this aligned frequency reuse scheme, each cell achieves  $2/5$  DoF (i.e.,  $1/5$  DoF per mobile user) and all significant interference is eliminated. Therefore, this orthogonal solution, the  $2/5$  DoF per cell using the aligned frequency reuse scheme, is DoF optimal solution and it corresponds to an improvement of 20% over the DoF using the conventional frequency reuse scheme.

### 3.2.4 DoF Gain of Optimal Scheme Over Conventional Frequency Reuse

Considering the optimal DoF solution in Theorem 10 and the DoF solution in Theorem 9 that is the achievable DoF using the conventional frequency reuse scheme, we can show that the improvement through optimal TIM scheme over the conventional frequency reuse scheme diminishes as  $\lambda$  increases, as follows.

$$\lim_{\lambda \rightarrow +\infty} \frac{\frac{1}{\frac{\lambda+2}{2}}}{2\lambda+3} = \lim_{\lambda \rightarrow +\infty} \frac{2\lambda+3}{2\lambda+4} = 1. \quad (3.5)$$

Therefore, the DoF gain through optimal TIM scheme over the conventional frequency reuse scheme diminishes when the interference topology becomes connected with more significant interference links, i.e., when the interference distance of the base stations increases.

### 3.2.5 Conclusion

The TIM problem for the infinite 1D (linear) downlink cellular networks, has been considered in this section, with the multi-layer interference topology, i.e., with an interference topology such that the significant interference in the TIM problem can be considered from base stations in cells beyond the immediately adjacent cells. The achievable DoF solution using the conventional frequency reuse scheme and the optimal DoF solution that can be achieved using an aligned frequency reuse scheme have been presented in this section. This section has shown that the DoF gain through optimal TIM scheme over the conventional frequency reuse scheme diminishes when the interference topology becomes connected with more significant interference links.

### 3.3 Linear Cellular Network with Uniformly Distributed Users

In this section, we consider TIM for an infinite 1D (linear) downlink cellular network. We consider uniformly distributed mobile users in each cellular cell, effectively creating a continuous distribution of users, aiming to study user classes based on different interference profiles rather than on actual individual users' positions. We also consider the construction of the TIM network topology by analyzing different interference thresholds. Unlike previous works, we use TIM at the user class level to find the system's DoF independent of the actual user position. Finally, after proposing a fractional coloring scheme that can achieve the optimal DoF solution, a trade-off between DoF and SIR is given.

#### 3.3.1 Infinite 1D (Linear) Downlink Cellular Network Model

For the infinite 1D (linear) downlink cellular network, as shown in Fig. 3.8, the cells are placed uniformly along a straight line and are locally connected. Each cell has a coverage region of length  $L$ . We consider one BS in each cell, with total transmit power  $P$ , located at the center of the cell. Each BS has  $M$  messages to be sent to its own  $M$  mobile users, and each user receives a unique message from its home BS. A total of  $M$  mobile users are distributed uniformly in each cell coverage region, with  $M$  chosen sufficiently large to be represented by a continuous linear distribution of users in the cells. Such a continuum representation is appropriate to perform a long-term resource allocation. To simplify the analysis, only path loss is considered in the channel gain. It is worth saying that TIM relying on reduced feedback, cannot manage fading at the BSs. However, the impact of fading could be introduced in the model by replacing the classical rate-SIR relation given in (3.17), by a modified version such as  $R = \beta\eta \cdot \log_2(1 + \Xi\text{SIR}^{(w)})$  following [44], where  $\beta$  and  $\Xi$  are the spectral efficiency and the SIR efficiency respectively for a given system in some specific conditions. The channel gain between a mobile user  $m$  in any cell in the infinite 1D (linear) downlink cellular network and a BS  $i$  of cell  $i$ , is

$$\gamma_{i,m} = \frac{\rho}{\delta_{i,m}^\alpha}, \quad (3.6)$$

where  $\delta_{i,m}$  is the distance between user  $m$  and BS  $i$ ,  $\alpha$  is the path loss factor, and  $\rho$  is the reference path loss for  $\delta_{i,m} = 1$  meter. Also, in the subsequent analysis, the interference perceived by any user in the network is as shown in Fig. 3.8, considered to come only from its home BS (when it is serving other users in the home cell) and from all other BSs up to the second layer of interference, i.e., from the BSs in its immediately adjacent cells and the first BSs following the immediately adjacent cells. Hence, the distance above which we consider no link, i.e.,  $\gamma_{i,m} = 0$ , for the interfering channels is lower bounded by  $5L/2$ .

#### 3.3.2 TIM Network Topology

##### Topology Construction

As introduced in [1], in TIM, an interference topology, i.e., a TIM network topology, must be determined to allow the calculation of the DoF via graph analysis. The path loss only model used herein allows a simple distance based interference connectivity threshold to be used for the TIM network topology construction. Therefore, the interference connectivity threshold is defined according to the interference distance  $D$ : significant interference links (i.e., connected interference links in the TIM representation) are only those such that  $\delta_{i,m} \leq D$ . In

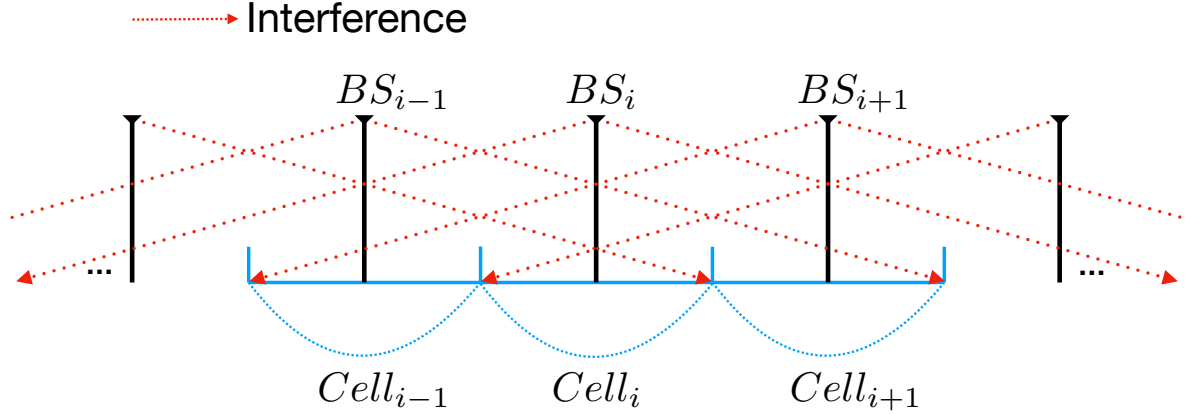

Figure 3.8: Infinite linear downlink cellular network model.

other words, in the TIM network topology, the interference links between nodes separated by a distance greater than  $D$  are considered disconnected (the corresponding channel coefficient is zero in the TIM representation), and the interference links between nodes separated by a distance  $D$  or less are considered connected (the corresponding channel coefficient is set to one in the TIM representation).

In our general case, the interference connectivity threshold for the TIM network topology construction is bounded as  $L/2 \leq D \leq 5L/2$  because of the considered path loss and interference models from section 3.3.1. However, in this section, we consider only the most interesting case when  $L/2 \leq D \leq L$ . Then, the TIM network topology for the infinite 1D (linear) downlink cellular network in Fig. 3.8, when  $L/2 \leq D \leq L$ , is shown in Fig. 3.9.

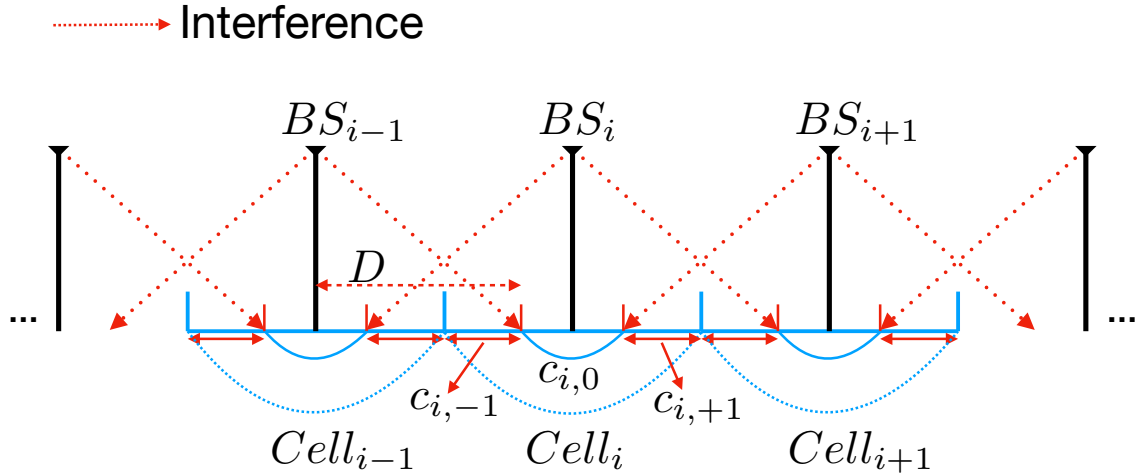

Figure 3.9: The TIM network topology of the infinite linear downlink cellular network in Fig. 3.8.

Each user  $m$  gets two kinds of links: the desired link, from its home BS, and significant interference link, from each BS  $i$  where  $\delta_{i,m} \leq D$ . The resulting TIM network topology is then convex, as defined in [12]. This means that given any user  $m$  whose connectivity link to a BS  $i$  is guaranteed, then any user node  $n \neq m$  whose distance  $\delta_{i,n} \leq \delta_{i,m}$  must also be connected

to the same BS  $i$ . Then, the TIM network topology shown in Fig. 3.9 for the infinite 1D (linear) downlink cellular network in Fig. 3.8 is chordal bipartite, since all 1D convex network topologies are chordal bipartite [13].

### Users Classification

We consider the case, for the TIM network topology construction, when  $L/2 \leq D \leq L$ . In this case, we can divide each cell  $i$  into three regions, as shown in Fig. 3.9: a cell center region  $c_{i,0}$  and two cell edge regions  $c_{i,-1}$  and  $c_{i,+1}$ . The length of the cell edge regions  $c_{i,-1}$  and  $c_{i,+1}$  is  $pL \forall i$ , and the length of the cell center region  $c_{i,0}$  is  $(1 - 2p)L \forall i$ , where  $p$ ,  $0 \leq p \leq 0.5$ , is the interference design parameter defined as

$$p = \frac{D - \frac{L}{2}}{L}. \quad (3.7)$$

Each user in cell region  $c_{i,j}$ ,  $j \in \{-1, 0, +1\}$ , shares the same interference profile, therefore, a cell region defines a class of users sharing the same interference. The set of users in region  $c_{i,0}$  is denoted by  $U_{i,0}$ , where these users see significant interference only from their home BS  $i$ , and it's defined as

$$U_{i,0} = \{\text{user } m \in \text{cell } i : \delta_{i-1,m} > D, \delta_{i+1,m} > D\}. \quad (3.8)$$

The set of users in region  $c_{i,-1}$  is denoted by  $U_{i,-1}$ , where these users see significant interference only from their home BS  $i$  and from the BS  $i - 1$ , and it's defined as

$$U_{i,-1} = \{\text{user } m \in \text{cell } i : \delta_{i-1,m} \leq D, \delta_{i+1,m} > D\}. \quad (3.9)$$

Finally, the set of users in region  $c_{i,+1}$  is denoted by  $U_{i,+1}$ , where these users see significant interference only from their home BS  $i$  and from the BS  $i + 1$ , and it's defined as

$$U_{i,+1} = \{\text{user } m \in \text{cell } i : \delta_{i-1,m} > D, \delta_{i+1,m} \leq D\}. \quad (3.10)$$

### 3.3.3 TIM: DoF Analysis

To study the DoF for the TIM network topology, defined in section 3.3.2 and shown in Fig. 3.9, we must first state some useful definitions as follows.

**Definition 21** (Message Conflict Graph). *The message conflict graph is an undirected graph, where each vertex represents a unique message from the set of all messages and an edge between two vertices representing two different messages exists only if the interference link between the BS of one message and the mobile user that desires the other message is a significant interference link in the TIM network topology (i.e., connected interference link in the TIM representation).*

**Definition 22** (User Class Based Conflict Graph). *The user class based conflict graph is an undirected graph, where each vertex represents a unique set of users  $U_{i,j}$  belonging to the same class of users and located in  $c_{i,j}$  and an edge between two vertices representing two different sets of users exists only if the interference links between the BS of one set of users and the other set of users are significant interference links in the TIM network topology (i.e., connected interference links in the TIM representation).*

**Remark 4.** The users who belong to the same class of users are represented by a unique vertex in the user class based conflict graph. The vertices representing the messages desired by these users form a clique in the message conflict graph. A clique in the message conflict graph is a set of vertices such that any two vertices in this set are adjacent, i.e., connected by an edge.

**Definition 23** (DoF Region). The DoF region is the closure of all the achievable messages' DoFs.

**Remark 5.** Since each user in the network desires a unique message then the achievable DoF for a user is the achievable DoF of the message desired by this user.

**Definition 24** (Symmetric DoF). The symmetric DoF is the largest DoF inside the DoF region that can be achieved simultaneously by all messages (i.e., by all users) in the network.

**Remark 6** (Symmetric DoF in the Conflict Graph). In the message conflict graph, the symmetric DoF is the largest DoF value that can be achieved simultaneously by all nodes. This corresponds to a weighted symmetric DoF in the user class based conflict graph, in which each node in the user class based conflict graph achieves the symmetric DoF value weighted by its corresponding clique size in the message conflict graph.

The user class based conflict graph, of the TIM network topology defined in section 3.3.2 and shown in Fig. 3.9, is presented in Fig. 3.10.

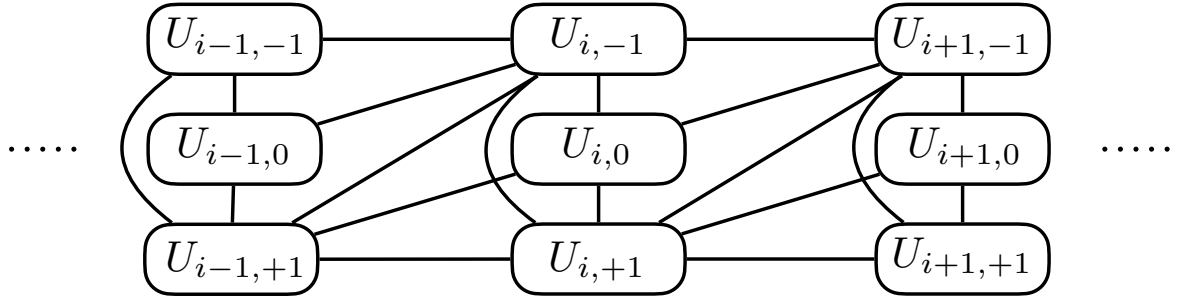

Figure 3.10: The user class based conflict graph of the TIM network topology in Fig. 3.9.

Now, let us proceed to the DoF solution for the TIM problem of the TIM network topology defined in section 3.3.2 and shown in Fig. 3.9. The DoF solution is per cell and is based on guaranteeing the symmetric DoF for all users in the infinite 1D (linear) downlink cellular network in Fig. 3.8. The following theorem presents the DoF solution.

**Theorem 11.** For the TIM network topology of the 1D (linear) downlink cellular network with the interference design parameter  $p$ ,  $0 \leq p \leq 0.5$ , the information theoretic DoF solution when all the users achieve the symmetric DoF value is

$$\eta = \frac{1}{1+p}, \quad (3.11)$$

where  $\eta$  is the DoF value per cell.

*Proof.* The DoF region for the TIM problem of a chordal bipartite TIM network topology is characterized through the cliques of the message conflict graph as presented in Theorem 8 [13]. Then, since the TIM network topology shown in Fig. 3.9, of the 1D (linear) downlink cellular network, is chordal bipartite, and using the user class based conflict graph shown in Fig. 3.10, the DoF region for the TIM problem of the TIM network topology of the 1D (linear) downlink cellular network is characterized by all the DoF solutions that satisfy

$$\begin{cases} d_{i-1,-1} + d_{i-1,0} + d_{i-1,+1} + d_{i,-1} \leq 1, & \forall i \\ d_{i-1,+1} + d_{i,-1} + d_{i,0} + d_{i,+1} \leq 1, & \forall i, \end{cases} \quad (3.12)$$

where  $d_{i,j}$ ,  $j \in \{-1, 0, +1\}$ , is the sum of the DoFs of the messages desired by the set of users  $U_{i,j}$ .

Knowing that a large number  $M$  of users are distributed uniformly and continuously inside each linear cell and since we are targeting the symmetric DoF for all users, then each cell region's DoF will be proportional to the size (length in 1D) of the cell region. We can then state that

$$d_{i,j} = p\eta, \quad \forall i \text{ and } \forall j \in \{-1, +1\}, \quad (3.13)$$

and

$$d_{i,0} = (1 - 2p)\eta, \quad \forall i, \quad (3.14)$$

where  $\eta$ ,  $\eta = Md_{\text{sym}}$ , is the DoF value per cell when all users achieve the symmetric user DoF value  $d_{\text{sym}}$ , and  $0 \leq p \leq 0.5$ .

Based on (3.12), (3.13) and (3.14), we get

$$3p\eta + (1 - 2p)\eta = 1, \quad (3.15)$$

thus completing the optimal DoF solution in (3.11).  $\square$

Fig. 3.11 shows the DoF per any cell,  $\eta$ , as function of the interference design parameter  $p$ . It is clear from (3.11), that as the interference design parameter  $p$  increases, the TIM network topology becomes more connected (i.e., more interference links are considered to be significant in the TIM network topology) and the DoF per cell decreases.

### 3.3.4 Trade-off Analysis Between DoF and SIR

Determining an optimal interference threshold is an important issue for TIM due to the trade-off between DoF and SIR. In this section, a fractional coloring scheme [45, 46, 47], achieving the optimal DoF solution for the TIM problem of the TIM network topology defined in section 3.3.2 and shown in Fig. 3.9, is proposed. Then, we present a SIR analysis based on the proposed fractional coloring scheme, for the infinite 1D (linear) downlink cellular network shown in Fig. 3.8. Finally, we show the trade-off between DoF and SIR.

In [13], the authors show that if a TIM network topology is chordal bipartite, then an orthogonal access scheme, such as fractional coloring, is sufficient to achieve the DoF region of the corresponding TIM problem. (see Theorem 8). Thus, since the TIM network topology of the 1D (linear) downlink cellular network, shown in Fig. 3.9, is chordal bipartite, we propose a fractional coloring scheme that achieves the optimal DoF solution of (3.11), illustrated in Fig. 3.12.



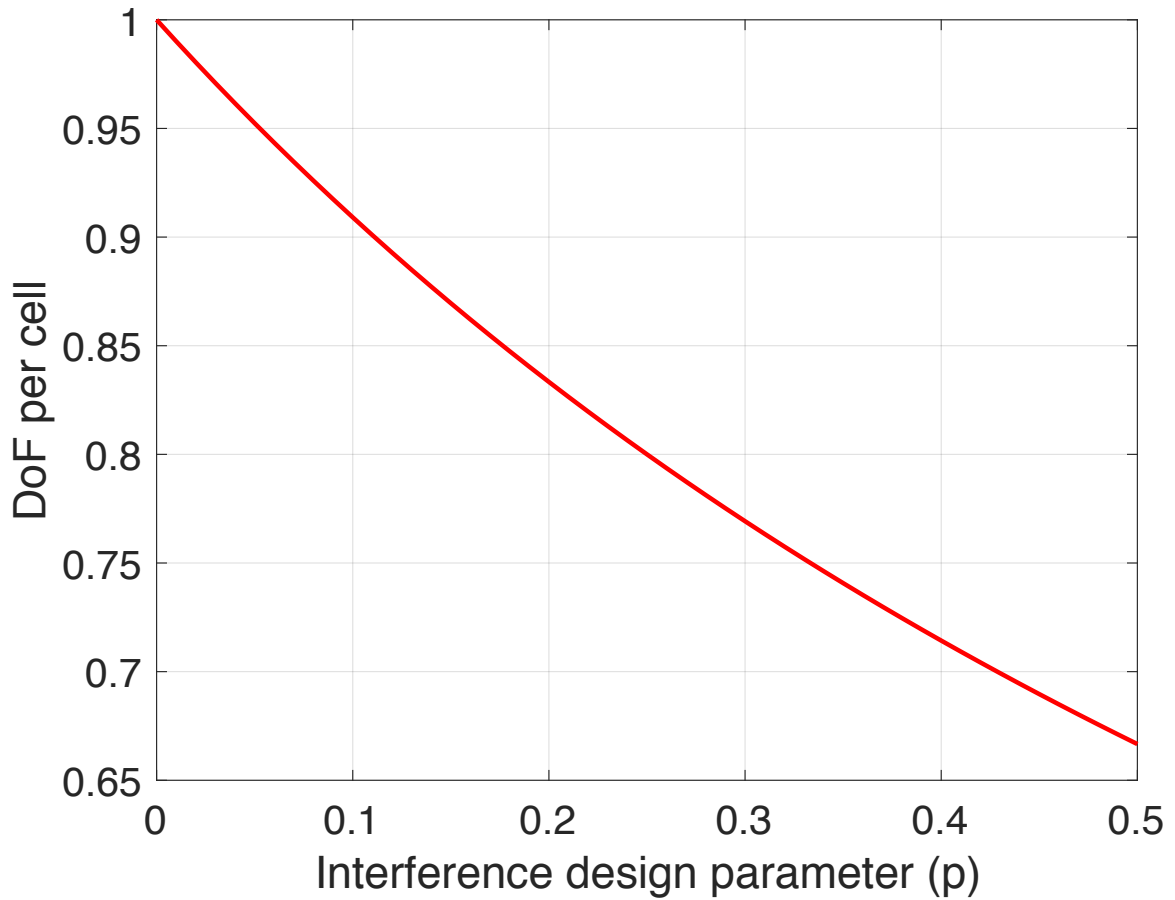

Figure 3.11: DoF per any cell as function of the interference design parameter  $p$ .

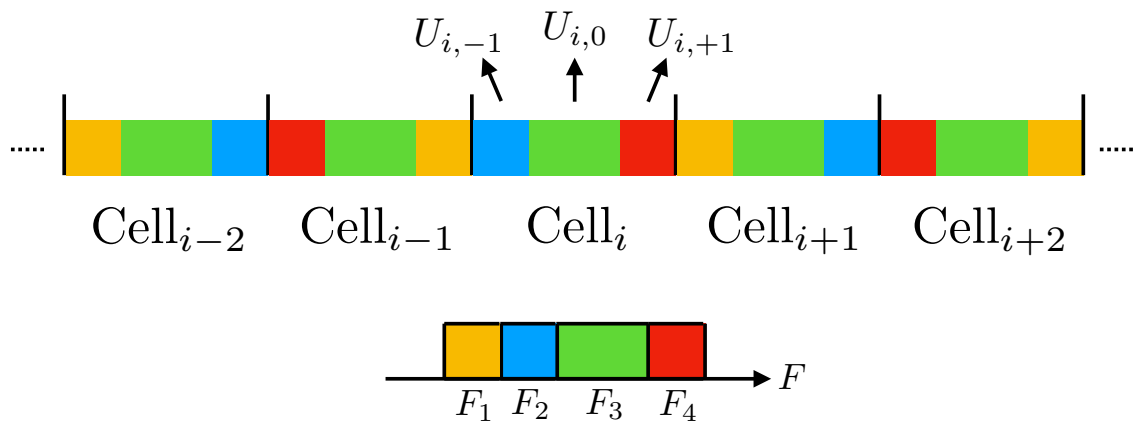

Figure 3.12: Fractional coloring scheme for the TIM problem of the TIM network topology shown in Fig. 3.9.

This fractional coloring scheme is designed, to achieve the optimal DoF solution in the TIM problem of the TIM network topology shown in Fig. 3.9, such that the different frequency

bands  $F_1$ ,  $F_2$ ,  $F_3$ , and  $F_4$  (referred by the 4 different colors: yellow, blue, green, and red respectively) are allocated for the different set of users  $U_{i,j}$ ,  $\forall i, \forall j \in \{-1, 0, +1\}$ , as shown in Fig. 3.12, in such a way that any two sets of users that have the same allocated frequency band do not have significant interference between them in the TIM representation, i.e., there is no edge between the vertices of these two sets of users in the corresponding user class based conflict graph. (see Def. 22).

The SIR for any mobile user  $m$  in cell  $i$ , in the infinite 1D (linear) downlink cellular network shown in Fig. 3.8, using the proposed fractional coloring scheme shown in Fig. 3.12, is

$$\text{SIR}_m = \frac{\gamma_{i,m}}{\sum_{j \in I} \gamma_{i+j,m}}, \quad (3.16)$$

where  $I = I_0 = \{-2, -1, +1, +2\}$  if  $m \in U_{i,0}$ ,  $I = I_{-1} = \{-2, +1\}$  if  $m \in U_{i,-1}$ , and  $I = I_{+1} = \{-1, +2\}$  if  $m \in U_{i,+1}$ .

Our objective is to find the cell rate when all users in the infinite 1D (linear) downlink cellular network have the same achievable symmetric user rate. This achievable cell rate is defined as follows

$$R_{\text{cell}} = \eta \cdot \log_2 \left( 1 + \text{SIR}^{(w)} \right), \quad (3.17)$$

where  $R_{\text{cell}}$  is the cell rate,  $\eta$  is the DoF value per cell as in (3.11) (multiplicative factor), and  $\text{SIR}^{(w)}$  is the worst user SIR (log factor), determined by searching, in any cell  $i$ , for the worst user SIR in the cell center region and the worst user SIR in the cell edge regions.

The worst user SIR in the cell center region  $c_{i,0}$ , denoted by  $\text{SIR}_{i,c}^{(w)}$ , is the SIR of user  $m \in U_{i,0}$  where  $\delta_{i,m} = \frac{L}{2} - pL$ . The worst user SIR in the cell edge regions  $c_{i,-1}$  and  $c_{i,+1}$ , denoted by  $\text{SIR}_{i,e}^{(w)}$ , is the SIR of user  $m \in U_{i,-1}$  or user  $m \in U_{i,+1}$  where  $\delta_{i,m} = \frac{L}{2}$ . The worst user SIR  $\text{SIR}^{(w)}$  at a given  $p$  is

$$\text{SIR}^{(w)} = \min \left( \text{SIR}_{i,c}^{(w)}, \text{SIR}_{i,e}^{(w)} \right). \quad (3.18)$$

The worst user SIR in the cell center region  $c_{i,0}$  and the worst user SIR in the cell edge regions  $c_{i,-1}$  and  $c_{i,+1}$ , in any cell  $i$ , are shown in Fig. 3.13, with path loss factor  $\alpha = 2$ , as function of the interference design parameter  $p$ .

The achievable cell rate when all users in the infinite 1D (linear) downlink cellular network have the same achievable symmetric user rate, is shown in Fig. 3.14, for path loss factor  $\alpha = 2$ , as function of the interference design parameter  $p$ .

The trade-off between DoF and SIR, seen in Fig. 3.14, is as follows. On the one hand, if the interference connectivity threshold is too high (high  $p$ ) then the TIM network topology becomes more connected with significant interference links (i.e., low DoF), and thus fewer opportunities to exploit TIM. Also, in this case with high SIR level, the cell rate will be low due to the low DoF at high  $p$ . On the other hand, if the interference connectivity threshold is too low (low  $p$ ) then the TIM network topology becomes less connected with significant interference links (i.e., high DoF), and hence, plenty of opportunities to exploit TIM will arise. However, the SIR itself will suffer yielding low cell rates. As a matter of fact, these results highlight that topological feedback may be sufficient in a network to obtain good performance, but the choice of the interference threshold is of utmost importance.

In our scenario the optimal choice of the interference threshold (optimal interference design

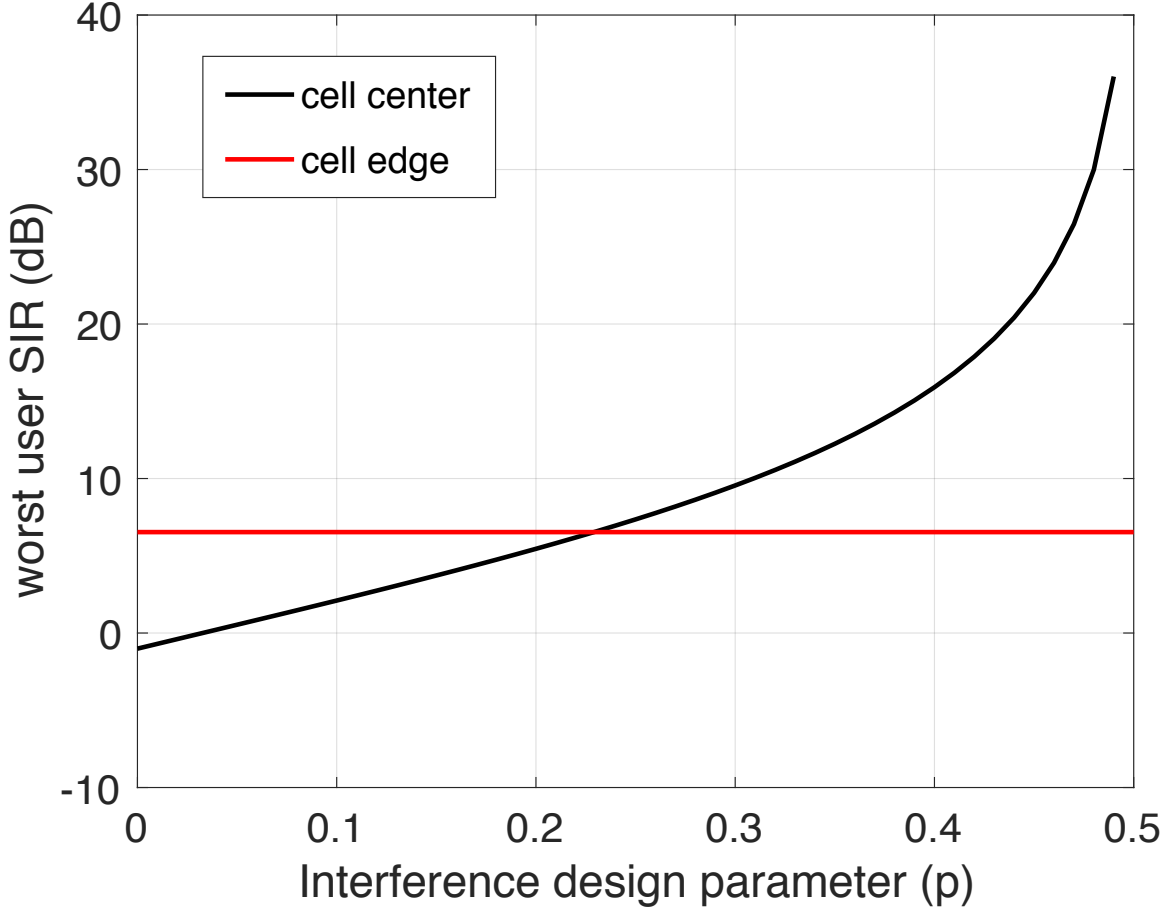

Figure 3.13: Worst user SIR as function of the interference design parameter  $p$ .

parameter  $p^*$ ) happens when

$$\text{SIR}_{i,c}^{(w)} = \text{SIR}_{i,e}^{(w)}, \quad (3.19)$$

where  $p = p^*$  fulfills (3.19), represented as the highest point of the curve in Fig. 3.14, with  $p^*$  being approximately 0.23.

### 3.3.5 Conclusion

The TIM problem for the infinite 1D (linear) downlink cellular network, has been considered in this section, under a continuous uniform distribution of mobile users. The TIM network topology then has been built upon the interference distance threshold, and the optimal DoF solution has been computed accordingly. A fractional coloring scheme achieving the DoF solution has been proposed in this section. Then, this section has shown the trade-off between DoF and SIR in the network performance relying on the interference threshold parameter. This latter result shows that the efficiency of a TIM approach is strongly impacted by an appropriate selection of the interference threshold parameter.

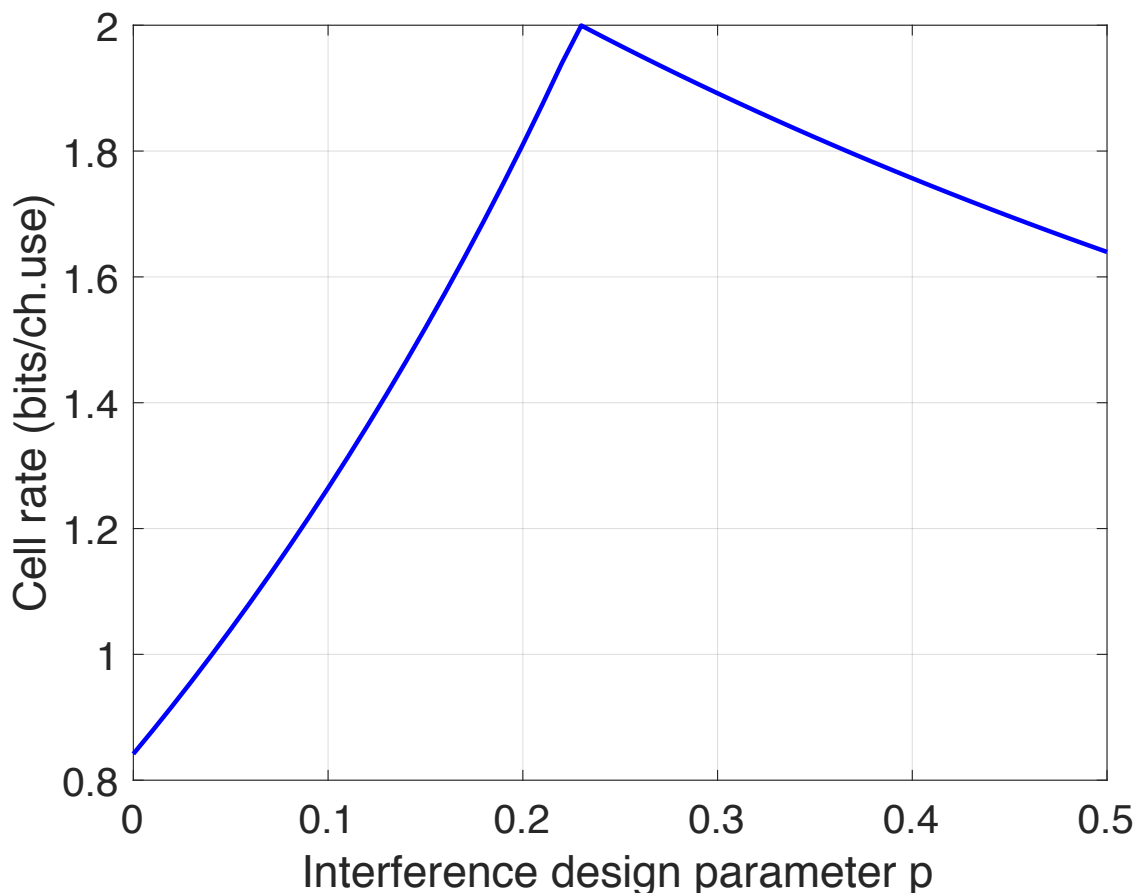

Figure 3.14: Cell Rate as function of the interference design parameter  $p$ .

### 3.4 Hexagonal Cellular Network with Uniformly Distributed Users

In this section, we consider TIM for an infinite 2D (hexagonal) downlink cellular network. We consider uniformly distributed mobile users in each cellular cell, effectively creating a continuous distribution of users, aiming to study user classes based on different interference profiles rather than on actual individual users' positions. We also consider the construction of the TIM network topology by analyzing different interference thresholds. Unlike previous works, we use TIM at the user class level to find the system's DoF independent of the actual user position. Finally, after proposing a fractional coloring scheme that can achieve the optimal DoF solution, a trade-off between DoF and SIR is given.

#### 3.4.1 Infinite 2D (Hexagonal) Downlink Cellular Network Model

For the infinite 2D (hexagonal) downlink cellular network, as shown in Fig. 3.15, the cells are placed uniformly in a hexagonal grid pattern and are locally connected. Each cell has a coverage region of radius  $R$  and area  $A_T$ . We consider one BS in each cell, with total transmit power  $P$ , equipped with an omni-directional antenna and located at the center of the cell. Each BS has  $M$  messages to be sent to its own  $M$  mobile users, and each user receives a

unique message from its home BS. A total of  $M$  mobile users are distributed uniformly in each cell coverage region, with  $M$  chosen sufficiently large to be represented by a spatial continuum distribution of users in the cells. Such a continuum representation is appropriate to perform a long-term resource allocation. The channel gain between a mobile user  $m$  in any cell in the infinite 2D (hexagonal) downlink cellular network and a BS  $i$  of cell  $i$ , is

$$\gamma_{i,m} = \frac{\rho}{\delta_{i,m}^\alpha}, \quad (3.20)$$

where  $\delta_{i,m}$  is the distance between user  $m$  and BS  $i$ ,  $\alpha$  is the path loss factor, and  $\rho$  is the reference path loss for  $\delta_{i,m} = 1$  meter. We consider the interference perceived by any user in the network to come only from its home BS (when it is serving other users in the home cell) and from all BSs in the first layer of interference, i.e., from the six BSs in its immediately adjacent cells, in its first surrounding layer given the hexagonal layout.

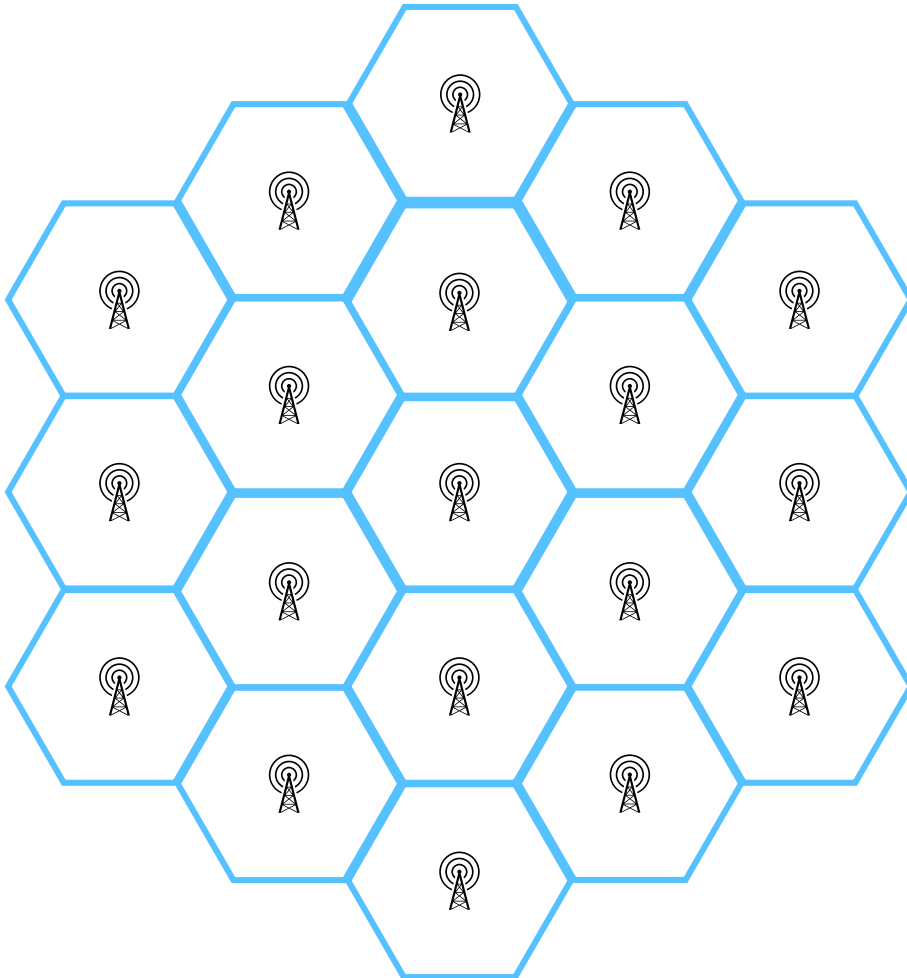

Figure 3.15: Infinite hexagonal downlink cellular network model.

### 3.4.2 TIM Network Topology

#### Topology Construction

The path loss only model used herein allows a simple distance based interference connectivity threshold to be used for the TIM network topology construction. Therefore, the interference connectivity threshold is defined according to the interference distance  $D$ : significant interference links (i.e., connected interference links in the TIM representation) are only those such that  $\delta_{i,m} \leq D$ . In other words, in the TIM network topology, the interference links between nodes separated by a distance greater than  $D$  are considered disconnected (the corresponding channel coefficient is zero in the TIM representation), and the interference links between nodes separated by a distance  $D$  or less are considered connected (the corresponding channel coefficient is set to one in the TIM representation).

In our general case, the interference connectivity threshold for the TIM network topology construction is bounded such that the interference perceived by any user in the network is considered to come only from its home BS (when it is serving other users in the home cell) and from the six BSs in its immediately adjacent cells, in its first surrounding layer given the hexagonal layout. However, in this section, we consider only the most interesting case when  $R \leq D \leq 3R/2$ . Then, the TIM network topology for the infinite 2D (hexagonal) downlink cellular network in Fig. 3.15, when  $R \leq D \leq 3R/2$ , is shown in Fig. 3.16. Each user  $m$  gets

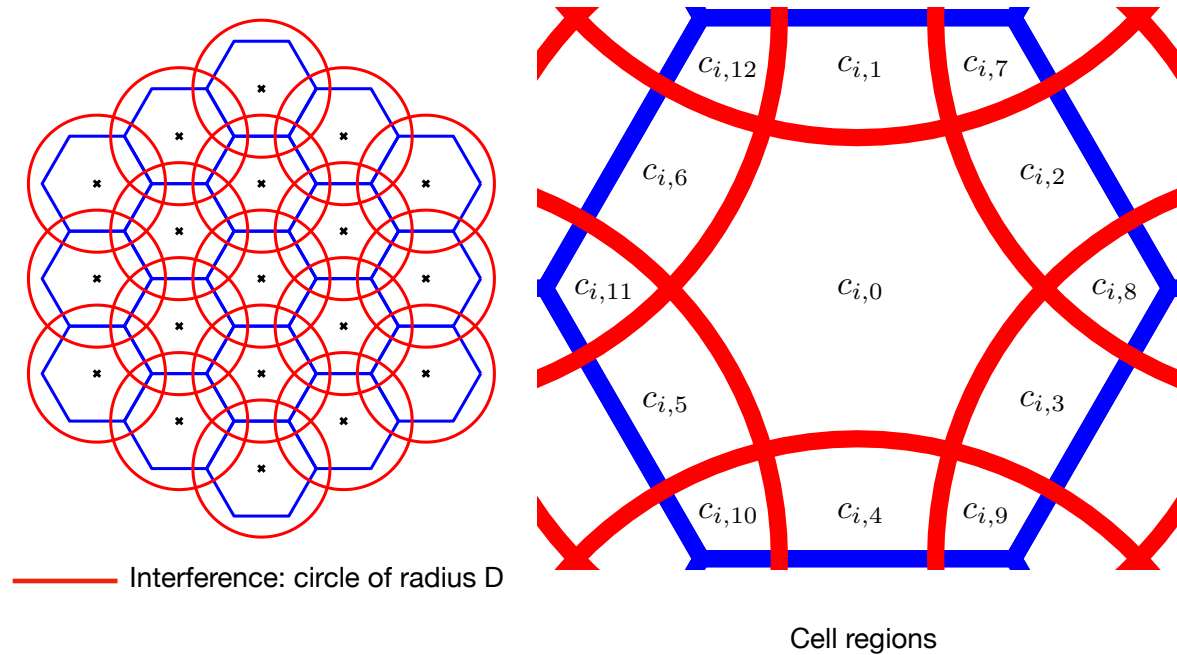

Figure 3.16: The TIM network topology of the infinite hexagonal downlink cellular network in Fig. 3.15.

two kinds of links: the desired link, from its home BS, and significant interference link, from each BS  $i$  where  $\delta_{i,m} \leq D$ .

### Users Classification

We consider the case, for the TIM network topology construction, when  $R \leq D \leq 3R/2$ . In this case, we can divide each cell  $i$  into 13 cell regions, as shown in Fig. 3.16: a cell center region  $c_{i,0}$  and 12 cell edge regions  $c_{i,j}$  where  $j \in \{1, 2, \dots, 12\}$ .

Each user in cell region  $c_{i,j}$ ,  $j \in \{0, 1, 2, \dots, 12\}$ , shares the same interference profile, therefore, a cell region defines a class of users sharing the same interference. The set of users in cell  $i$  in the cell center region  $c_{i,0}$  is denoted by  $U_{i,0}$ . These users see significant interference only from their home BS  $i$ . The set of users in cell  $i$  in the cell edge region  $c_{i,j}$  where  $j \in \{1, 2, \dots, 6\}$  is denoted by  $U_{i,j}$  where  $j \in \{1, 2, \dots, 6\}$ . These users see significant interference only from their home BS and from the BS in their unique immediately adjacent cell. Finally, the set of users in cell  $i$  in the cell edge region  $c_{i,j}$  where  $j \in \{7, 8, \dots, 12\}$  is denoted by  $U_{i,j}$  where  $j \in \{7, 8, \dots, 12\}$ . These users see significant interference only from their home BS and from the BSs in their two immediately adjacent cells.

### 3.4.3 TIM: DoF Analysis

The user class based conflict graph, of the TIM network topology defined in section 3.4.2 and shown in Fig. 3.16, is presented in Fig. 3.17. The graph construction is based on the same properties as the user class based conflict graph of the 1D linear model in section 3.3.3 in Fig. 3.10, however, in order to aid in readability, some simplifications were made: 1) the edges between users classes belonging to the same cell are omitted; 2) an edge connecting a given user class to a whole cell aggregates all edges connecting this user class to all user classes in that cell.

Now, let us proceed to the DoF solution for the TIM problem of the TIM network topology defined in section 3.4.2 and shown in Fig. 3.16. The DoF solution is per cell and is based on guaranteeing the symmetric DoF for all users in the infinite 2D (hexagonal) downlink cellular network in Fig. 3.15. Through the same analysis as in section 3.3.3, and using the conflict graph of Fig. 3.17, the following theorem presents the DoF solution of the 2D hexagonal TIM problem.

**Theorem 12.** *For the TIM network topology of the 2D (hexagonal) downlink cellular network with the interference connectivity threshold  $D$ ,  $R \leq D \leq 3R/2$ , the DoF solution when all the users achieve the symmetric DoF value is*

$$\eta = \frac{1}{1 + \frac{A_1 + A_2}{A_T}}, \quad (3.21)$$

where  $\eta$  is the DoF value per cell, and  $A_T$ ,  $A_1$  and  $A_2$  are defined, using [48], as follows

$$A_T = \frac{3\sqrt{3}R^2}{2}, \quad (3.22)$$

$$A_1 = \frac{1}{6}\pi D^2 - R^2 \frac{\sqrt{3}}{4}, \quad (3.23)$$

$$A_2 = \frac{\frac{\sqrt{3}}{4}b^2 + 3 \left[ D^2 \arcsin\left(\frac{b}{2D}\right) - \frac{b}{4}\sqrt{4D^2 - b^2} \right]}{3}, \quad (3.24)$$

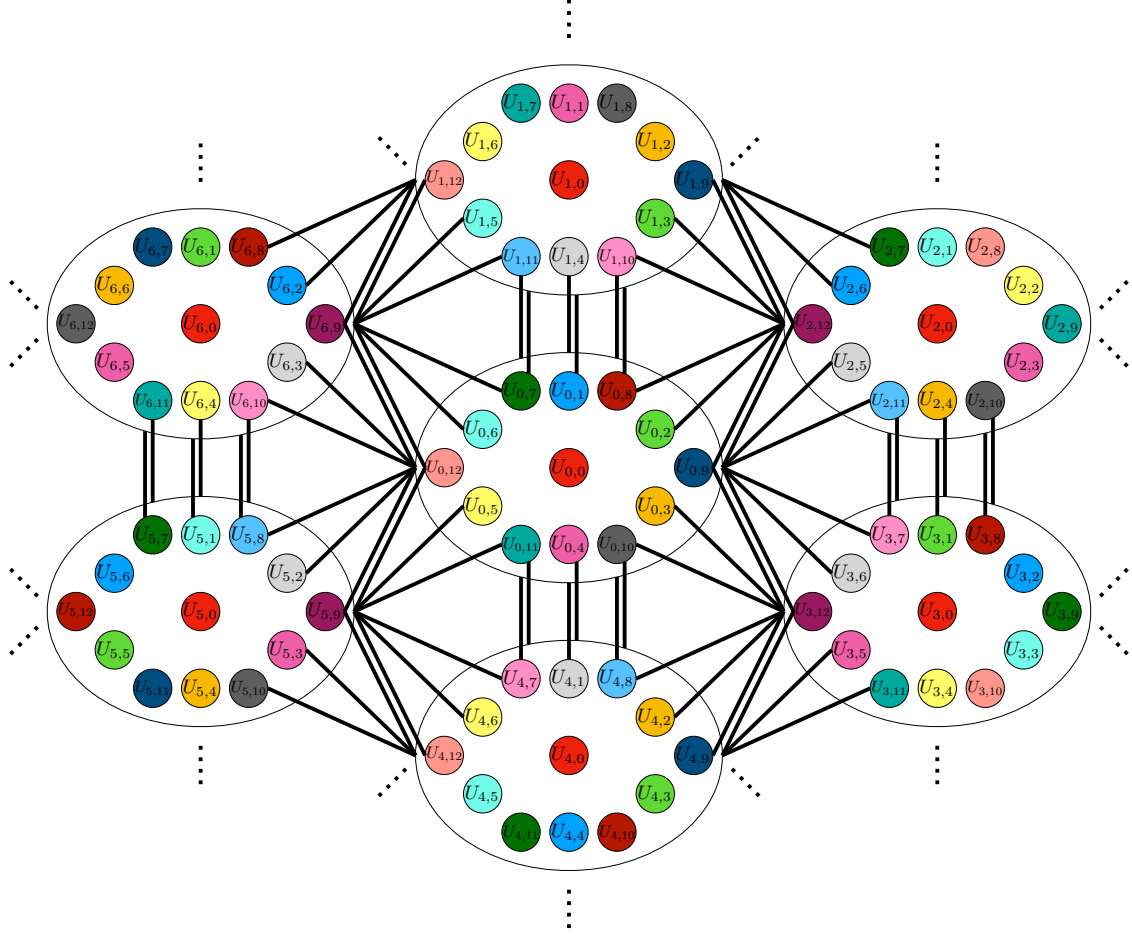

Figure 3.17: The user class based conflict graph of the TIM network topology in Fig. 3.16. The 17 different colors shown in this figure correspond to the fractional coloring scheme solution in section 3.4.4.

where  $b$  is defined as

$$b = \sqrt{3D^2 - \frac{3R^2}{2} - 3R\sqrt{D^2 - \frac{3R^2}{4}}}. \quad (3.25)$$

and  $A_T$  denotes the area of any cell  $i$ ,  $A_2$  denotes the area of any cell edge region  $c_{i,j}$ ,  $j \in \{7, 8, \dots, 12\}$ , in any cell  $i$ , and  $A_1 - 2A_2$  denotes the area of any cell edge region  $c_{i,j}$ ,  $j \in \{1, 2, \dots, 6\}$ , in any cell  $i$ .

*Proof.* The proof can be found similarly to the proof of Theorem 11, considering that the DoF for each cell region is proportional to the cell region size (area).  $\square$

Fig. 3.18 shows the DoF per any cell,  $\eta$ , as function of the interference distance  $D$ , where the cell radius  $R$  is chosen to be 1 km. The horizontal range in Fig. 3.18 is between 1 and 1.5 due to the range of  $D$  given in section 3.4.2. Based on the DoF solution in Theorem 12 and from Fig. 3.18, it is clear that as the interference distance  $D$  increases, the TIM network topology becomes more connected (i.e., more interference links are considered to be significant



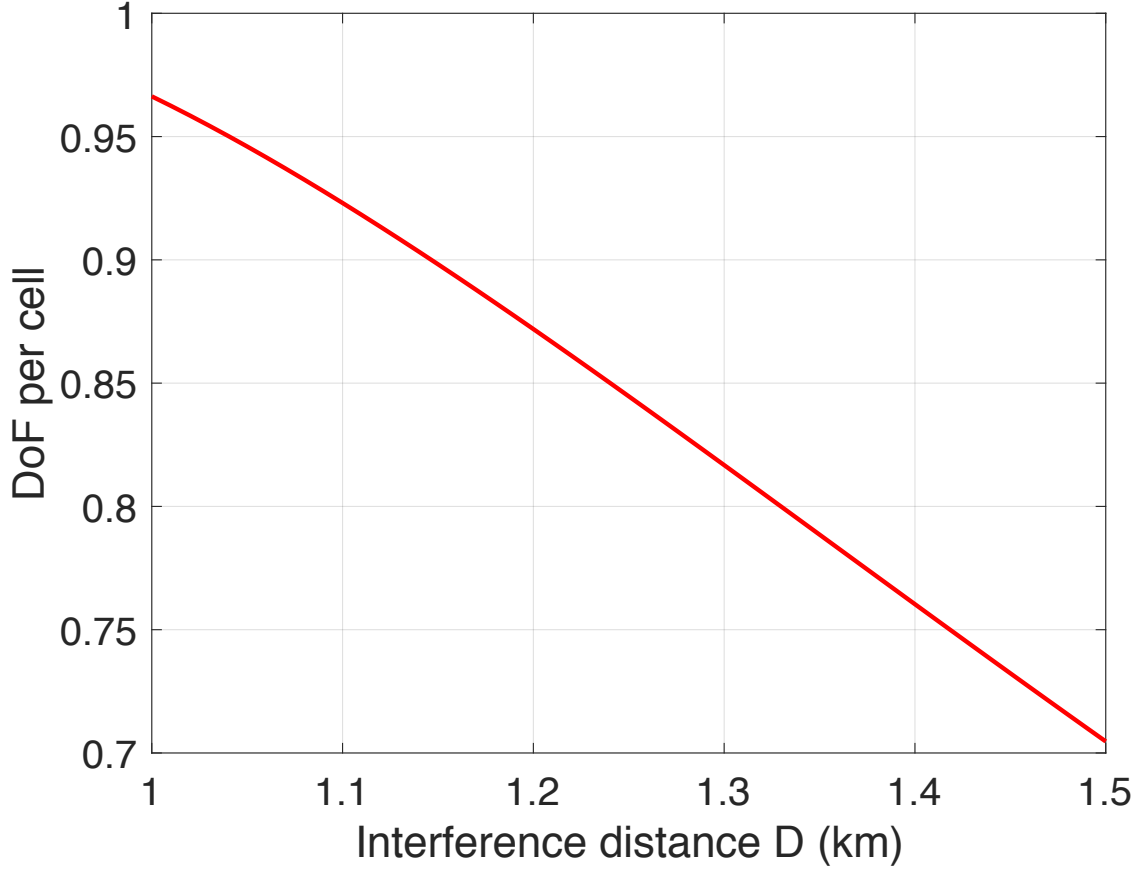

Figure 3.18: DoF per any cell as function of the interference distance  $D$ .

in the TIM network topology) and the DoF per cell decreases.

### 3.4.4 Trade-off Analysis Between DoF and SIR

Determining an optimal interference threshold is an important issue for TIM due to the trade-off between DoF and SIR. In this section, a fractional coloring scheme [45, 46, 47], achieving the DoF solution for the TIM problem of the TIM network topology defined in section 3.4.2 and shown in Fig. 3.16, is proposed. Then, we consider a SIR analysis based on the proposed fractional coloring scheme, for the infinite 2D (hexagonal) downlink cellular network shown in Fig. 3.15, to show the trade-off between DoF and SIR.

The fractional coloring scheme that achieves the DoF solution of (3.21) is illustrated in Fig. 3.17. This fractional coloring scheme is designed, to achieve the DoF solution in the TIM problem of the TIM network topology shown in Fig. 3.16, such that 17 different frequency bands (referred by 17 different colors) are allocated for the different set of users  $U_{i,j}$ ,  $\forall i, \forall j \in \{0, 1, \dots, 12\}$ , as shown in Fig. 3.17, in such a way that any two sets of users that have the same allocated frequency band do not have significant interference between them in the TIM representation, i.e., there is no edge between the vertices of these two sets of users in the corresponding user class based conflict graph. (see Def. 22).

Our objective is to find the cell rate when all users in the infinite 2D (hexagonal) downlink cellular network have the same achievable symmetric user rate. This achievable cell rate is defined as follows

$$R_{\text{cell}} = \eta \cdot \log_2 \left( 1 + \text{SIR}^{(w)} \right), \quad (3.26)$$

where  $R_{\text{cell}}$  is the cell rate,  $\eta$  is the DoF value per cell as in (3.21) (multiplicative factor), and  $\text{SIR}^{(w)}$  is the worst user SIR (log factor), determined by searching, in any cell  $i$ , for the worst user SIR in the cell center region and the worst user SIR in the cell edge regions.

The achievable cell rate when all users in the infinite 2D (hexagonal) downlink cellular network have the same achievable symmetric user rate, is shown in Fig. 3.19, for path loss factor  $\alpha = 2$ , as function of the interference distance  $D$ , where the cell radius  $R$  is chosen to be 1 km. The horizontal range in Fig. 3.19 is between 1 and 1.5 due to the range of  $D$  given in section 3.4.2.

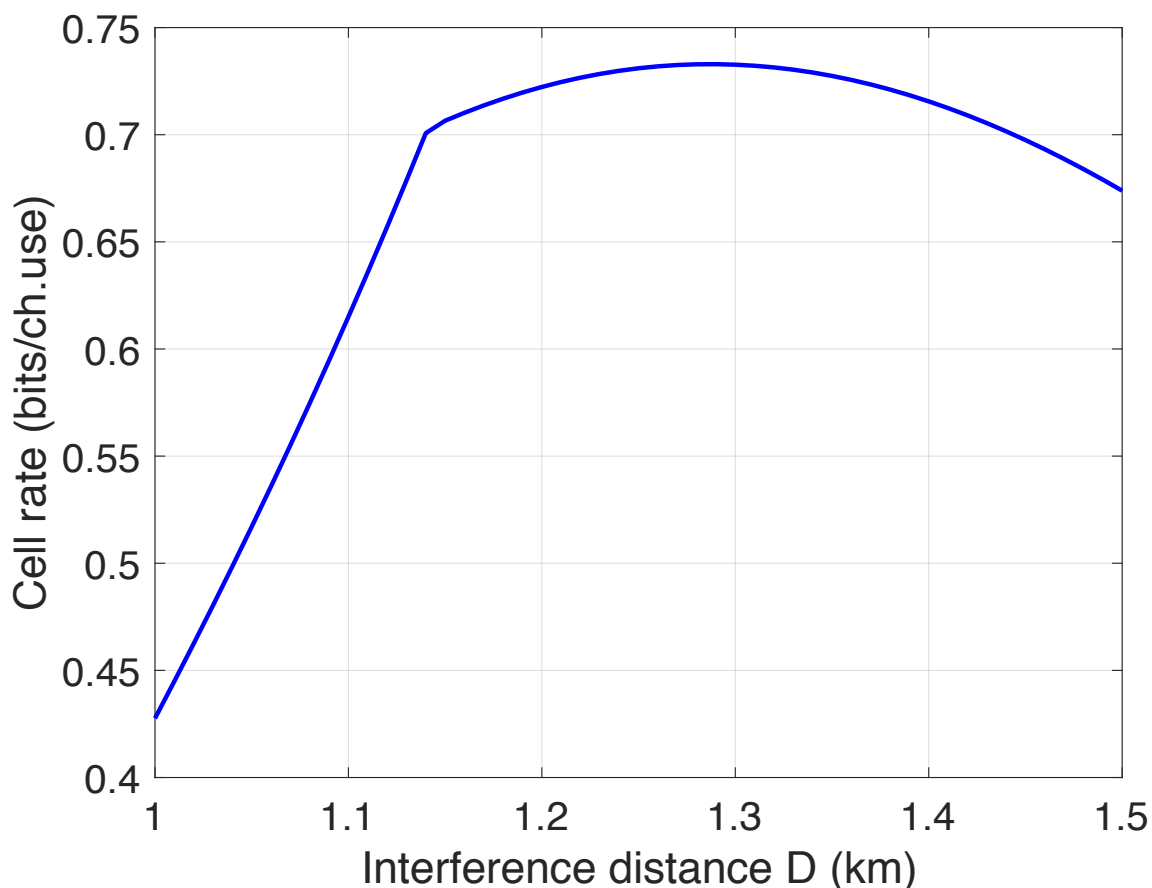

Figure 3.19: Cell Rate as function of the interference distance  $D$ .

The trade-off between DoF and SIR, seen in Fig. 3.19, is as follows. On the one hand, if the interference connectivity threshold is too high (high  $D$ ) then the TIM network topology becomes more connected with significant interference links (i.e., low DoF), and thus fewer opportunities to exploit TIM. Also, in this case with high SIR level, the cell rate will be low due to the low DoF at high  $D$ . On the other hand, if the interference connectivity threshold

is too low (low  $D$ ) then the TIM network topology becomes less connected with significant interference links (i.e., high DoF), and hence, plenty of opportunities to exploit TIM will arise. However, the SIR itself will suffer yielding low cell rates. As a matter of fact, these results highlight that topological feedback may be sufficient in a network to obtain good performance, but the choice of the interference threshold is of utmost importance.

In our scenario the optimal choice of the interference threshold (optimal interference distance  $D^*$ ) represented as the highest point of the curve in Fig. 3.19, with  $D^*$  being approximately 1.29 km.

#### 3.4.5 Conclusion

The TIM problem for the infinite 2D (hexagonal) downlink cellular network, has been considered in this section, under a continuous uniform distribution of mobile users. The TIM network topology then has been built upon the interference distance threshold, and the optimal DoF solution has been computed accordingly. A fractional coloring scheme achieving the DoF solution has been proposed in this section. Then, this section has shown the trade-off between DoF and SIR in the network performance relying on the interference threshold parameter. This latter result shows that the efficiency of a TIM approach is strongly impacted by an appropriate selection of the interference threshold parameter.

# — 4 —

---

## Achievable Rates in TIM

A common point of all TIM studies is that they depend heavily on the interference topology construction model given in [1]. Therein, an interference topology is fixed whatever power levels are used by the transmitters. While fixing the interference topology allows for easier analysis, as developed in [1], it has an important drawback since, in reality, the interference topology depends on the transmission power levels of all transmitters and we will not have the same interference topology for different transmission powers. In this chapter, we propose a new interference topology construction approach, for the TIM problem of wireless networks, that addresses this drawback. We introduce a new finite SNR framework that is able to control the interference topology more accurately and with more flexibility.

In [1], we identified two key issues:

- A unique pre-determined SNR interference threshold: the interference topology of the wireless network is constructed under the constraint that the sum of the weak interference is lower than  $N_0$ . (We will relax this assumption).
- When the limit of the SNR toward infinity is considered in [1], the interference topology is fixed. (We will show that this assumption is not accurate to represent a wireless network).

Starting from [1], we propose a new interference topology construction approach, for the TIM problem of wireless networks, that can be used more efficiently to deal with the non-asymptotic SNR regime. Also, with this approach, we are able to cope with the finite SNR regime and to evaluate the impact of the interference threshold used to build the interference topology.

### 4.1 System Model

Consider a wireless communication network, as shown in Fig. 4.1, consisting of  $K$  TXs, labeled,  $S_1, S_2, \dots, S_K$ , and  $K$  RXs, labeled,  $D_1, D_2, \dots, D_K$ . Let  $\mathcal{W} = \{W_1, W_2, \dots, W_K\}$  be the set of all messages to be transmitted in the network. We assume that the network supports unicast

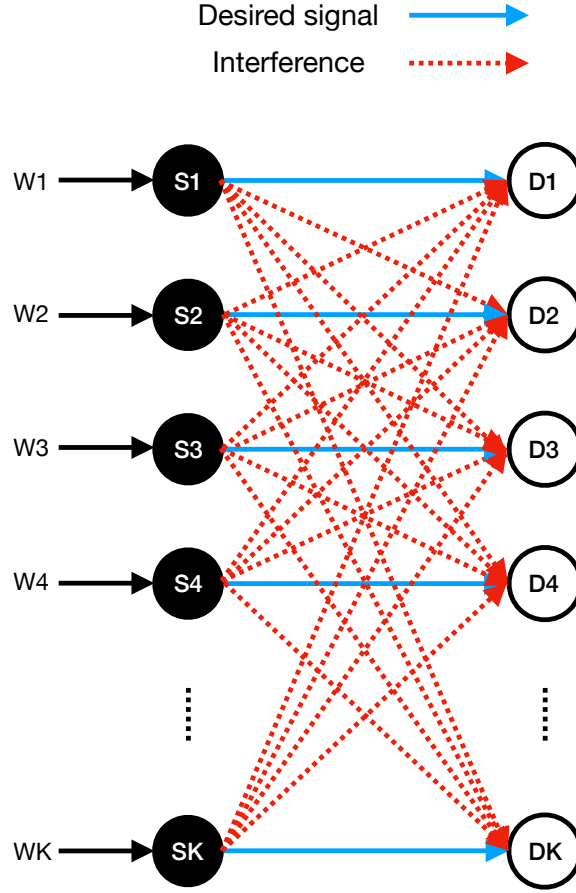
Figure 4.1: Wireless communication network with  $K$  users.

transmissions, where TX  $S_k$ ,  $k \in \{1, 2, \dots, K\}$ , sends a unique message  $W_k$  to a unique RX  $D_k$ . Each TX  $S_k$  uses a power  $P_k$  to transmit its unique message  $W_k$ , and each RX  $D_k$  is subject to interference from every TX  $S_{k'}$ ,  $k' \in \{1, 2, \dots, K\}/\{k\}$ . The developments in this work are also valid for a broadcast style channel where each TX  $S_k$  aims at transmitting  $M_k$  unique messages,  $M_k \leq K$ , to  $M_k$  unique RXs. Indeed, this setting can be considered as the point-to-point one by splitting each TX  $S_k$  into  $M_k$  independent co-located TXs. The wireless network includes two kinds of communication links: the desired links, i.e., the links  $S_k \rightarrow D_k$ ,  $\forall k \in \{1, 2, \dots, K\}$ , and the interference links, i.e., the links  $S_{k'} \rightarrow D_k$ ,  $\forall k, k' \in \{1, 2, \dots, K\}$  and  $k' \neq k$ .

The channel input-output relationships are defined as

$$y_i(n) = \sum_{j=1}^K h_{ij} x_j(n) + z_i(n), \quad (4.1)$$

where, over the  $n$ th channel use,  $x_j(n)$  is the transmitted symbol from message source  $S_j$ ,  $j \in \{1, 2, \dots, K\}$ ,  $y_i(n)$  is the received symbol at message destination  $D_i$ ,  $i \in \{1, 2, \dots, K\}$ ,  $z_i(n)$  is the additive noise at message destination  $D_i$ , and  $h_{ij}$  is the constant channel coefficient between message source  $S_j$  and message destination  $D_i$ . All symbols belong to the field  $\mathbb{C}$ .

We also denote  $g_{ij} = |h_{ij}|^2$ , the flat fading channel gain associated to each source-destination link. The term  $z_i(n)$  is the i.i.d. complex circularly symmetric additive white Gaussian noise term, with zero mean and variance  $N_0$ .

## 4.2 The Classical TIM Formulation

Before we introduce our formulation for the interference topology construction approach for TIM, let us first recall the classical approach of the interference topology construction in the multi-user unicast TIM problem, as proposed in [1].

First, let us recall the definition of the interference topology of the unicast TIM problem of the wireless network defined in section 4.1.

Interference topology is an interference links classification that only allows a distinction, at each destination  $D_i$ , between weak interference links (the interference links at destination  $D_i$  where the corresponding channel coefficients are zero in the TIM representation), i.e., the interference links that have cumulative interference contribution at  $D_i$  below the interference threshold, and significant interference links (the interference links at destination  $D_i$  where the corresponding channel coefficients are set to one in the TIM representation), i.e., the interference links that have cumulative interference contribution at  $D_i$  above the interference threshold.

We consider the graph representation for TIM and we define the interference topology of the unicast TIM problem as follows.

**Definition 25** (Interference Topology  $\mathcal{T}$ ). *Interference topology  $\mathcal{T}$  is an undirected bipartite graph with  $K$  vertices on one side, each vertex representing a unique message source  $S_j$ , and  $K$  vertices on the other side, each vertex representing a unique message destination  $D_i$ . Each message source  $S_j$  wishes to send a unique message  $W_j \in \mathcal{W}$ , while each message destination  $D_i$  desires a unique message  $W_i \in \mathcal{W}$ . Every edge in this graph connects a vertex from the source side to a vertex on the destination side. Two kinds of edges are existing in this graph: edges representing the desired links, and edges representing the significant interference links. All other possible edges, i.e., the edges representing the weak interference links, will be suppressed in this interference graph representation.*

Two important constraints are considered, in [1], to construct an interference topology  $\mathcal{T}$ :

1. The average transmit power at each TX  $S_j$ ,

$$P_j := \frac{1}{N} \left[ \sum_{n=1}^N |x_j(n)|^2 \right], \quad (4.2)$$

where  $N$  is the number of channel uses, is set to ensure the following nominal interference-free SNR for all desired links  $S_j \rightarrow D_j$ , given as

$$\frac{g_{jj}P_j}{N_0} \geq \gamma, \quad \forall j \in \{1, 2, \dots, K\}, \quad (4.3)$$

where  $\gamma$  denotes the desired SNR target for all desired links.

2. Once the transmission powers  $P_j$  are chosen, the interference level at each  $D_i$ , is fixed and given by

$$I_i = \sum_{j=1; j \neq i}^K g_{ij} P_j. \quad (4.4)$$

An interference topology  $\mathcal{T}$  can be determined in which for each destination  $D_i$ , the interference links set,  $\mathcal{I}_i = \{S_j \rightarrow D_i; j \in \{1, 2, \dots, K\}, j \neq i\}$ , is divided into two subsets, a set of significant interference links  $\mathcal{S}_{i,\mathcal{T}}$  and a set of weak interference links  $\bar{\mathcal{S}}_{i,\mathcal{T}}$ , in which  $\mathcal{I}_i = \mathcal{S}_{i,\mathcal{T}} \cup \bar{\mathcal{S}}_{i,\mathcal{T}}$  and  $\mathcal{S}_{i,\mathcal{T}} \cap \bar{\mathcal{S}}_{i,\mathcal{T}} = \emptyset$ . This decomposition is not necessarily unique as it depends on the different possible combinations of the interference links. In [1], the set  $\bar{\mathcal{S}}_{i,\mathcal{T}}$  is chosen arbitrarily such that its elements' sum-interference verifies

$$\sum_{\{S_j \rightarrow D_i\} \in \bar{\mathcal{S}}_{i,\mathcal{T}}} g_{ij} P_j \leq N_0, \quad (4.5)$$

with  $\mathcal{S}_{i,\mathcal{T}}$  taken as the complement of  $\bar{\mathcal{S}}_{i,\mathcal{T}}$ .

Once an interference topology  $\mathcal{T}$  is determined based on constraints (4.3) and (4.5), the resource allocation process will guarantee a lower bound on the SINR at each  $D_i$ , denoted as  $\xi_{i,\mathcal{T}}$ , given as

$$\xi_{i,\mathcal{T}} \geq \alpha_{\mathcal{T}} \frac{\gamma}{2}, \quad \forall i \in \{1, 2, \dots, K\}, \quad (4.6)$$

where  $\alpha_{\mathcal{T}}$  is the loss factor imposed by non-orthogonal transmission schemes when  $\mathcal{T}$  is considered. Typically,  $\alpha_{\mathcal{T}} = 1$  when an orthogonal resource allocation is used, while  $0 < \alpha_{\mathcal{T}} < 1$  when non-orthogonal linear coding is used [1].

This model guarantees a lower bounded SINR and therefore an achievable bound on the capacity region for this network.

### 4.3 TIM: A New Formulation for the Topology Construction

In [1], Jafar fixed an interference topology, according to Definition 25 and the constraint in (4.5), and studied the DoF, i.e., when the transmission powers tend to infinity. While this approach provides an enticing way to evaluate the theoretical performance limit of the topological interference representation of the wireless network, it does not hold for the performance of the wireless network itself. Indeed, as transmission powers tend to infinity, the interference level of the neglected interference links at each  $D_i$ , i.e., the weak interference links associated to  $\bar{\mathcal{S}}_i$ , also increases, and therefore, the constraint in (4.5) fails.

We now propose a different formulation for the interference topology construction to cope with the aforementioned drawbacks, while retaining the elegant DoF analysis in [1]. Our objectives are threefold: first, to deal with the finite SNR regime and not only with the asymptotic one; second, to improve its accuracy when analyzing the capacity as a function of the SNR; and third, to account for a flexible interference threshold (not just  $N_0$ ) that can model different SNR requirements.

#### 4.3.1 Normalized Network Model

We start by choosing the desired SNR target  $\gamma$ . We assume the network performs a power control to guarantee the same SNR target for all desired links  $S_j \rightarrow D_j$ . Hence, the transmission

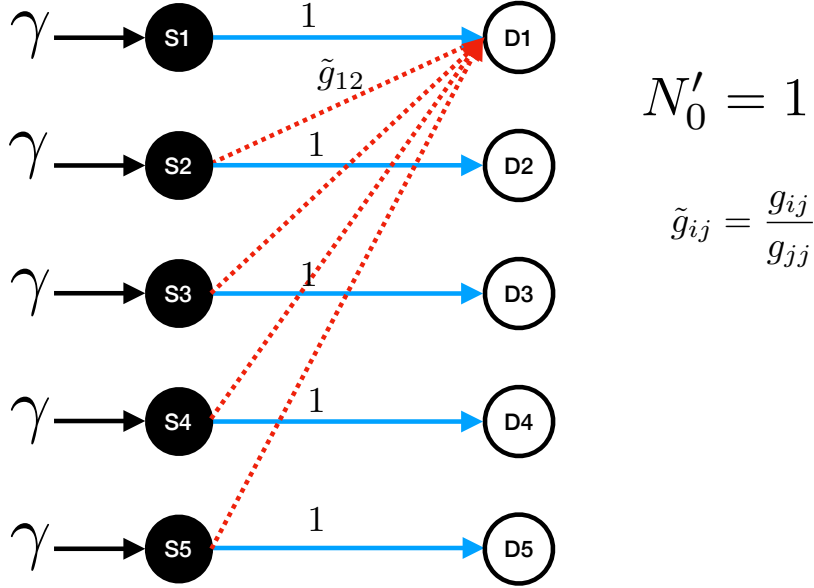
 Figure 4.2: Normalized network model with  $K = 5$ .

powers are fixed according to

$$P_j = \frac{N_0 \gamma}{g_{jj}}, \quad \forall j \in \{1, 2, \dots, K\}. \quad (4.7)$$

Let us formulate an equivalent system by scaling the transmission powers and the noise values such that:

1. The normalized noise power at each destination  $D_i$  is set to 1.
2. The normalized channel gains associated to the desired links are also set to  $\tilde{g}_{jj} = 1$ ,  $\forall j \in \{1, 2, \dots, K\}$ .
3. The equivalent transmission powers are consequently set to  $P'_j = \gamma$ ,  $\forall j \in \{1, 2, \dots, K\}$ .
4. The normalized interference channel gains are set to  $\tilde{g}_{ij} = \frac{g_{ij}}{g_{jj}}$ ,  $\forall i, j \in \{1, 2, \dots, K\}$  and  $i \neq j$ .

A normalized network model for the wireless communication network, in Fig. 4.1, with  $K = 5$ , is shown in Fig. 4.2. This model corresponds to a normalization of the standard TIM model defined in [1].

### 4.3.2 SNR-Independent Interference Threshold

Based on the normalized model described in section 4.3.1, the transmission power from each message source  $S_j$  is  $\gamma$ , and the noise level at each message destination  $D_i$  is unitary. Let us turn our interest to the interference strength at message destination  $D_i$  which is now given by

$$I_i = \sum_{j=1; j \neq i}^K \tilde{g}_{ij} \cdot \gamma, \quad (4.8)$$



and the SINR at  $D_i$  turns out to be

$$\xi_i = \frac{\gamma}{1 + \gamma \sum_{j=1; j \neq i}^K \tilde{g}_{ij}}. \quad (4.9)$$

Let us consider a TIM problem  $\mathbf{TIM}(\mathcal{T})$  with an interference topology  $\mathcal{T}$  to be determined, and let us generalize the constraint given in (4.5) for an arbitrary interference threshold  $\tau_{\mathcal{T}}$ . The weak interference links, associated to  $\bar{\mathcal{S}}_{i,\mathcal{T}}$ , at message destination  $D_i$ , will be neglected. In order to determine the interference topology  $\mathcal{T}$ , we choose the set  $\bar{\mathcal{S}}_{i,\mathcal{T}}$ , at each  $D_i$ , such that its elements sum interference verifies

$$\sum_{\{S_j \rightarrow D_i\} \in \bar{\mathcal{S}}_{i,\mathcal{T}}} \tilde{g}_{ij} \cdot \gamma \leq \tau_{\mathcal{T}}, \quad (4.10)$$

which can be rewritten as

$$\sum_{\{S_j \rightarrow D_i\} \in \bar{\mathcal{S}}_{i,\mathcal{T}}} \tilde{g}_{ij} \leq \beta_{\mathcal{T}}, \quad (4.11)$$

where  $\beta_{\mathcal{T}} = \frac{\tau_{\mathcal{T}}}{\gamma}$  is a normalized interference threshold that leads to the construction of the topology  $\mathcal{T}$ . Note that, a unique value for  $\beta_{\mathcal{T}}$  may lead to the construction of different interference topologies  $\mathcal{T}$ .

In (4.11), the left hand term relies only on the channel coefficients and not on  $\gamma$ . This means that an interference topology  $\mathcal{T}$  built for a given  $\beta_{\mathcal{T}}$  is valid for any couple  $(\gamma, \tau_{\mathcal{T}})$  such that  $\tau_{\mathcal{T}}/\gamma = \beta_{\mathcal{T}}$ . Finally, for each value of  $\beta_{\mathcal{T}}$ , a TIM instance (i.e., an interference topology  $\mathcal{T}$  in the TIM problem  $\mathbf{TIM}(\mathcal{T})$ ) can be built and evaluated for a full range of SNRs. Note that, while a given  $\beta_{\mathcal{T}}$  value corresponds to an interference topology  $\mathcal{T}$ , such a topology may be obtained through a range of  $\beta_{\mathcal{T}}$  values.

### 4.3.3 Interference Topology: Interference Classification

In order to classify, for a given  $\beta_{\mathcal{T}}$ , the interference links at message destination  $D_i$  (interference links in  $\mathcal{I}_i$ ), as significant interference links and weak interference links, we define,  $\forall i \in \{1, 2, \dots, K\}$ , two sets as follows

$$\mathcal{I}_{i,\mathcal{T}}^+ = \{\{S_j \rightarrow D_i\} \in \mathcal{I}_i \mid \tilde{g}_{ij} > \beta_{\mathcal{T}}\}, \quad (4.12)$$

and

$$\mathcal{I}_{i,\mathcal{T}}^- = \{\{S_j \rightarrow D_i\} \in \mathcal{I}_i \mid \tilde{g}_{ij} \leq \beta_{\mathcal{T}}\}, \quad (4.13)$$

where  $\mathcal{I}_{i,\mathcal{T}}^+ \cup \mathcal{I}_{i,\mathcal{T}}^- = \mathcal{I}_i$ . All the links in  $\mathcal{I}_{i,\mathcal{T}}^+$  can be classified as significant interference links, i.e,  $\mathcal{I}_{i,\mathcal{T}}^+ \subseteq \mathcal{S}_{i,\mathcal{T}}$ . However, all the links in  $\mathcal{I}_{i,\mathcal{T}}^-$  are not necessarily weak, since their interference accumulate and may have collectively a power contribution at  $D_i$  greater than  $\tau_{\mathcal{T}}$ . Let us denote by  $\mathcal{F}_{i,\mathcal{T}}$  the set of all subsets of  $\mathcal{I}_{i,\mathcal{T}}^-$ , where  $(\mathcal{I}_{i,\mathcal{T}}^-, \mathcal{F}_{i,\mathcal{T}})$  is a measurable space and  $|\mathcal{F}_{i,\mathcal{T}}| = 2^{|\mathcal{I}_{i,\mathcal{T}}^-|}$ . One element of  $\mathcal{F}_{i,\mathcal{T}}$  is denoted by  $\Phi_{i,\mathcal{T}}^q$ ,  $q \in \{1, \dots, |\mathcal{F}_{i,\mathcal{T}}|\}$ . Then, any element  $\Phi_{i,\mathcal{T}}^q$  of  $\mathcal{F}_{i,\mathcal{T}}$  is a weak interference links set if  $\sum_{\{S_j \rightarrow D_i\} \in \Phi_{i,\mathcal{T}}^q} \tilde{g}_{ij} \leq \beta_{\mathcal{T}}$ . The set of all possible

weak interference links sets at  $D_i$  is

$$\Omega_{i,\mathcal{T}} = \left\{ \Phi_{i,\mathcal{T}}^q \in \mathcal{F}_{i,\mathcal{T}}; \sum_{\{S_j \rightarrow D_i\} \in \Phi_{i,\mathcal{T}}^q} \tilde{g}_{ij} \leq \beta_{\mathcal{T}} \right\}, \quad (4.14)$$

If two sets  $\Phi_{i,\mathcal{T}}^q \in \Omega_{i,\mathcal{T}}$  and  $\Phi_{i,\mathcal{T}}^r \in \Omega_{i,\mathcal{T}}$ ,  $r \in \{1, \dots, |\mathcal{F}_{i,\mathcal{T}}|\}$ , verify  $\Phi_{i,\mathcal{T}}^q \subset \Phi_{i,\mathcal{T}}^r$ , then we say that  $\Phi_{i,\mathcal{T}}^r$  dominates  $\Phi_{i,\mathcal{T}}^q$ . A set  $\Phi_{i,\mathcal{T}}^q$  is said dominant if it is not dominated by any other  $\Phi_{i,\mathcal{T}}^r \in \Omega_{i,\mathcal{T}}$ . We select, at each  $D_i$ , a dominant  $\Phi_{i,\mathcal{T}}^q$ , defined as  $\bar{\mathcal{S}}_{i,\mathcal{T}}$ , to construct a relevant interference topology  $\mathcal{T}$  for a given  $\beta_{\mathcal{T}}$  by suppressing all the interference links associated to  $\bar{\mathcal{S}}_{i,\mathcal{T}}$ .

#### 4.3.4 Fundamental Trade-off between DoF and SINR Maximization

Once an interference topology  $\mathcal{T}$  is determined based on constraints (4.7) and (4.11), the collective interference at  $D_i$  from the weak interference links in  $\bar{\mathcal{S}}_{i,\mathcal{T}}$  is upper bounded by  $\gamma\beta_{\mathcal{T}}$ , and the linear coding resource allocation process will guarantee a lower bound on the effective SINR at each  $D_i$ , given as

$$\xi_{i,\mathcal{T}} \geq \alpha_{\mathcal{T}} \frac{\gamma}{1 + \gamma\beta_{\mathcal{T}}}, \quad \forall i \in \{1, 2, \dots, K\}, \quad (4.15)$$

where  $\alpha_{\mathcal{T}}$  is the non-orthogonality loss factor already mentioned.

Let us remind that, according to [1], linear coding allows to increase the DoF by using non-orthogonal linear vectors, but in turns result in a degraded SINR due to the non-orthogonal linear coding penalty factor  $\alpha_{\mathcal{T}}$ . This penalty comes from the fact that the receiver has to project the received signal in the interference-free subspace [3]. Therefore, the following engineering tradeoff holds: either the resource allocation is restricted to an orthogonal allocation strategy providing a maximal SINR value, i.e.,  $\frac{\gamma}{1 + \gamma\beta_{\mathcal{T}}}$ , at each message destination, at the price however of a limited DoF, or the resource allocation can exploit a linear coding strategy, which usually increases the DoF, at the price of reduced individual SINRs.

In our model, when  $\gamma$  tends to infinity, the SINR  $\xi_{i,\mathcal{T}}$  is not infinite as in Jafar's model [1], but is bounded by  $\frac{\alpha_{\mathcal{T}}}{\beta_{\mathcal{T}}}$ ,  $\forall i \in \{1, 2, \dots, K\}$ , which fits better with the properties of the real wireless network behind the interference topology model. Consequently, the DoF analysis does not provide the slope of an infinite capacity in the high SNR regime, but rather a maximal capacity. The only solution to get an infinite capacity is to use an orthogonal resource sharing between all pairs of nodes.

## 4.4 Achievable Rates in TIM

As we explained in section 4.3, the theoretical limit proposed in [1] is valid for a TIM instance but not for the underlying wireless network. In this section, we are going to characterize the achievable rate region of the wireless network defined in section 4.1. First, let us denote by  $\mathcal{P}$  the set of all possible interference topologies of the wireless network. For a TIM problem  $\mathbf{TIM}(\mathcal{T})$  with an interference topology  $\mathcal{T} \in \mathcal{P}$ , we can characterize an achievable rate region as follows

$$\mathcal{R}_{\mathcal{T}} \supset \bigcup_{\mathbf{D}_{\mathcal{T}} \in \mathcal{D}_{\mathcal{T}}} \left[ \mathbf{D}_{\mathcal{T}} \cdot \log_2 \left( 1 + \frac{\alpha_{\mathcal{T}, \mathbf{D}_{\mathcal{T}}} \gamma}{1 + \gamma\beta_{\mathcal{T}}} \right) \right], \quad (4.16)$$

where the joint DoF  $\mathbf{D}_{\mathcal{T}}$  is an achievable DoF allocation inside the DoF region  $\mathcal{D}_{\mathcal{T}}$  of the TIM problem  $\mathbf{TIM}(\mathcal{T})$ , defined as

$$\mathbf{D}_{\mathcal{T}} = [\text{DoF}_{\mathcal{T}}(W_1), \text{DoF}_{\mathcal{T}}(W_2), \dots, \text{DoF}_{\mathcal{T}}(W_K)]^t, \quad (4.17)$$

where  $\text{DoF}_{\mathcal{T}}(W_k)$ ,  $k \in \{1, 2, \dots, K\}$ , is an achievable DoF allocation, per message  $W_k$ , inside the DoF region  $\mathcal{D}_{\mathcal{T}}$  of the TIM problem  $\mathbf{TIM}(\mathcal{T})$ , and  $\alpha_{\mathcal{T}, \mathbf{D}_{\mathcal{T}}}$  is the loss factor imposed by non-orthogonal transmission schemes, when  $\mathcal{T}$  is considered, that leads to the achievable DoF solution  $\mathbf{D}_{\mathcal{T}}$  in the TIM problem  $\mathbf{TIM}(\mathcal{T})$ . Typically,  $\alpha_{\mathcal{T}, \mathbf{D}_{\mathcal{T}}} = 1$  when an orthogonal resource allocation is used, while  $0 < \alpha_{\mathcal{T}, \mathbf{D}_{\mathcal{T}}} < 1$  when non-orthogonal linear coding is used [1].

We recall that a range of values of  $\beta_{\mathcal{T}}$  may lead to the construction of the same interference topology  $\mathcal{T}$ . We are interested in finding the  $\beta_{\mathcal{T}}$  value, out of all the possible  $\beta_{\mathcal{T}}$  values that lead to the construction of this interference topology  $\mathcal{T}$ , that provides the largest achievable rate region in (4.16) for the same  $\mathcal{D}_{\mathcal{T}}$  (fixed interference topology  $\mathcal{T}$ ). This is going to be stated in the following definition and theorem.

**Definition 26** (Lowest  $\beta$  Value for  $\mathcal{T}$ ). *The lowest  $\beta$  value that leads to the construction of an interference topology  $\mathcal{T}$  is defined as*

$$\beta_{\mathcal{T}}^* = \max_i \sum_{\{S_j \rightarrow D_i\} \in \bar{S}_{i, \mathcal{T}}} \tilde{g}_{ij}. \quad (4.18)$$

**Theorem 13** (Achievable Rate Region: Finite SNR Regime). *The achievable rate region, in the finite SNR regime, through linear coding schemes, of a wireless network can be defined as the union of the achievable rate regions associated to all TIM problems of all possible interference topologies of the wireless network, as follows*

$$\mathcal{R}_{\mathcal{W}} \supset \bigcup_{\mathbf{D}_{\mathcal{T}} \in \mathcal{D}_{\mathcal{T}}; \forall \mathcal{T} \in \mathcal{P}} \left[ \mathbf{D}_{\mathcal{T}} \cdot \log_2 \left( 1 + \frac{\alpha_{\mathcal{T}, \mathbf{D}_{\mathcal{T}}} \gamma}{1 + \gamma \beta_{\mathcal{T}}^*} \right) \right], \quad (4.19)$$

*Proof.* The result in (4.19) follows naturally from the fact that, out of all possible  $\beta_{\mathcal{T}}$  values that leads to the construction of a given interference topology  $\mathcal{T}$  with a fixed  $\mathcal{D}_{\mathcal{T}}$ , the  $\beta_{\mathcal{T}}$  value associated with the largest achievable rate region is  $\beta_{\mathcal{T}}^*$  (the lowest  $\beta_{\mathcal{T}}$  value), since this maximizes the log term in (4.19). Hence, all achievable rate regions given by higher  $\beta_{\mathcal{T}}$  values must be included in the one with  $\beta_{\mathcal{T}}^*$ .  $\square$

For a sufficiently large SNR, i.e.,  $\gamma \rightarrow \infty$ , we can state the following corollary.

**Corollary 1** (Achievable Rate Region: Asymptotic SNR Regime). *The achievable rate region, in the asymptotic SNR regime, through linear coding schemes, of a wireless network can be defined as follows*

$$\mathcal{R}_{\mathcal{W}} \supset \bigcup_{\mathbf{D}_{\mathcal{T}} \in \mathcal{D}_{\mathcal{T}}; \forall \mathcal{T} \in \mathcal{P}} \left[ \mathbf{D}_{\mathcal{T}} \cdot \log_2 \left( 1 + \frac{\alpha_{\mathcal{T}, \mathbf{D}_{\mathcal{T}}}}{\beta_{\mathcal{T}}^*} \right) \right]. \quad (4.20)$$

For a TIM problem  $\mathbf{TIM}(\mathcal{T})$  with an interference topology  $\mathcal{T}$ , we can characterize an achievable symmetric rate per message, i.e., a rate  $R_{\mathcal{T}}(\gamma)$  that can be achieved by each message  $W_k \in \mathcal{W}$  through linear coding, as follows

$$R_{\mathcal{T}}(\gamma) = d_{\mathcal{T}} \cdot \log_2 \left( 1 + \frac{\alpha_{\mathcal{T}} \gamma}{1 + \gamma \beta_{\mathcal{T}}^*} \right), \quad (4.21)$$

where  $d_{\mathcal{T}}$  is the symmetric DoF per message, i.e., the maximal DoF that can be achieved by each message  $W_k \in \mathcal{W}$  in the TIM problem  $\mathbf{TIM}(\mathcal{T})$  through linear coding,  $\alpha_{\mathcal{T}}$  is the non-orthogonal linear coding penalty factor that leads to the symmetric DoF solution  $d_{\mathcal{T}}$  in the TIM problem  $\mathbf{TIM}(\mathcal{T})$ . In the following theorem and corollary, we are going to characterize an achievable symmetric rate per message  $W_k \in \mathcal{W}$  of the wireless network defined in section 4.1.

**Theorem 14** (Achievable Symmetric Rate: Finite SNR Regime). *An achievable symmetric rate, in the finite SNR regime, through linear coding schemes, of a wireless network can be defined as the highest achievable symmetric rate among the achievable symmetric rates associated to all TIM problems of all possible interference topologies of the wireless network, as follows*

$$R_{\mathcal{W}}(\gamma) = \max_{\mathcal{T} \in \mathcal{P}} R_{\mathcal{T}}^*(\gamma), \quad (4.22)$$

where  $R_{\mathcal{T}}^*(\gamma)$  is the achievable symmetric rate associated to the TIM problem  $\mathbf{TIM}(\mathcal{T})$ , defined as

$$R_{\mathcal{T}}^*(\gamma) = d_{\mathcal{T}} \cdot \log_2 \left( 1 + \frac{\alpha_{\mathcal{T}} \gamma}{1 + \gamma \beta_{\mathcal{T}}^*} \right). \quad (4.23)$$

*Proof.* The result in (5.20) follows naturally from the fact that, out of all possible  $\beta_{\mathcal{T}}$  values that leads to the construction of a given interference topology  $\mathcal{T}$  with a fixed  $d_{\mathcal{T}}$ , the  $\beta_{\mathcal{T}}$  value associated with the highest achievable symmetric rate  $R_{\mathcal{T}}^*(\gamma)$  is  $\beta_{\mathcal{T}}^*$  (the lowest  $\beta_{\mathcal{T}}$  value), since this maximizes the log term in (4.21). Hence, all achievable symmetric rates given by higher  $\beta_{\mathcal{T}}$  values must be lower than the one with  $\beta_{\mathcal{T}}^*$ .  $\square$

For a sufficiently large SNR, i.e.,  $\gamma \rightarrow \infty$ , we can state the following corollary.

**Corollary 2** (Achievable Symmetric Rate: Asymptotic SNR Regime). *An achievable symmetric rate, in the asymptotic SNR regime, through linear coding schemes, of a wireless network can be defined as follows*

$$R_{\mathcal{W}}(\gamma) = \max_{\mathcal{T} \in \mathcal{P}} \left[ d_{\mathcal{T}} \cdot \log_2 \left( 1 + \frac{\alpha_{\mathcal{T}}}{\beta_{\mathcal{T}}^*} \right) \right]. \quad (4.24)$$

## 4.5 Extreme Interference Topologies: Achievable Rate Analysis

In this section, we will analyze the performance of the two extreme interference topologies of a wireless network: the *fully connected* and the *fully disconnected*, to understand when they outperform the other interference topologies of the wireless network. We define the two extreme interference topologies, the fully connected and the fully disconnected, as follows.

**Definition 27** (Fully Connected Interference Topology  $\mathcal{T}_c$ ). *An interference topology  $\mathcal{T}$  is said to be fully connected if and only if all interference links are significant interference links. We will denote the fully connected topology as  $\mathcal{T}_c$ .*

**Property 1** (Lowest  $\beta_{\mathcal{T}_c}$  for  $\mathcal{T}_c$ ). *The lowest  $\beta_{\mathcal{T}_c}$  value for the fully connected interference topology  $\mathcal{T}_c$  is  $\beta_{\mathcal{T}_c}^* = 0$ .*

**Definition 28** (Fully Disconnected Interference Topology  $\mathcal{T}_d$ ). *An interference topology  $\mathcal{T}$  is said to be fully disconnected if and only if all interference links are weak interference links. We will denote the fully disconnected topology as  $\mathcal{T}_d$ .*

**Property 2** (Lowest  $\beta_{\mathcal{T}_d}$  for  $\mathcal{T}_d$ ). *The lowest  $\beta_{\mathcal{T}_d}$  value for the fully disconnected interference topology  $\mathcal{T}_d$  is*

$$\beta_{\mathcal{T}_d}^* = \max_i \sum_{j=1; j \neq i}^K \tilde{g}_{ij} = \beta_m. \quad (4.25)$$

For the fully connected interference topology  $\mathcal{T}_c$ , the maximal DoF that can be achieved by each message  $W_k \in \mathcal{W}$  in the TIM problem  $\mathbf{TIM}(\mathcal{T}_c)$  is  $d_{\mathcal{T}_c} = 1/K$ , and the resource allocation is restricted to orthogonal allocation with  $\alpha_{\mathcal{T}_c} = 1$ . Hence, for  $\mathcal{T}_c$ , an achievable symmetric rate  $R_{\mathcal{T}_c}^*(\gamma)$  per each message  $W_k \in \mathcal{W}$ , is defined as

$$R_{\mathcal{T}_c}^*(\gamma) = \frac{1}{K} \log_2(1 + \gamma). \quad (4.26)$$

The achievable rate  $R_{\mathcal{T}_c}^*(\gamma)$  for  $\mathcal{T}_c$  defined in (4.26) tends to infinity when  $\gamma \rightarrow \infty$ . This is the unique interference topology solution for which the rate may scale with  $\log(\gamma)$  but in this case the optimal allocation is  $1/K$ .

For the fully disconnected interference topology  $\mathcal{T}_d$ , the maximal DoF that can be achieved by each message  $W_k \in \mathcal{W}$  in the TIM problem  $\mathbf{TIM}(\mathcal{T}_d)$  is  $d_{\mathcal{T}_d} = 1$ , and in this case, full reuse is performed with  $\alpha_{\mathcal{T}_d} = 1$ . Hence, for  $\mathcal{T}_d$ , an achievable symmetric rate  $R_{\mathcal{T}_d}^*(\gamma)$  per each message  $W_k \in \mathcal{W}$ , is defined as

$$R_{\mathcal{T}_d}^*(\gamma) = \log_2 \left( 1 + \frac{\gamma}{1 + \gamma \beta_m} \right). \quad (4.27)$$

**Definition 29** (Extreme Interference Topologies Rate  $R_E(\gamma)$ ). *We can define an achievable symmetric rate for the extreme interference topologies, denoted by  $R_E(\gamma)$ , as follows.*

$$R_E(\gamma) = \max(R_{\mathcal{T}_c}^*(\gamma), R_{\mathcal{T}_d}^*(\gamma)). \quad (4.28)$$

**Theorem 15** (Extreme Interference Topologies Rate  $R_E(\gamma)$ ). *There exists a  $\gamma$  value called  $\gamma_e$  such that*

$$R_E(\gamma) = \begin{cases} R_{\mathcal{T}_d}^*(\gamma); & \gamma < \gamma_e \\ R_{\mathcal{T}_c}^*(\gamma); & \gamma \geq \gamma_e \end{cases} \quad (4.29)$$

and  $\gamma_e$  can be evaluated by solving the following

$$R_{\mathcal{T}_c}^*(\gamma_e) = R_{\mathcal{T}_d}^*(\gamma_e). \quad (4.30)$$

*Proof.* This follows from the fact that,  $R_{\mathcal{T}_c}^*(\gamma)$  and  $R_{\mathcal{T}_d}^*(\gamma)$  are continuously increasing, and  $\lim_{\gamma \rightarrow 0} R_{\mathcal{T}_c}^*(\gamma) < \lim_{\gamma \rightarrow 0} R_{\mathcal{T}_d}^*(\gamma)$  and  $\lim_{\gamma \rightarrow \infty} R_{\mathcal{T}_c}^*(\gamma) > \lim_{\gamma \rightarrow \infty} R_{\mathcal{T}_d}^*(\gamma)$ .  $\square$

The following theorems state when the extreme interference topologies outperform any other intermediate interference topology  $\mathcal{T} \in \mathcal{P}$  in terms of the achievable symmetric rate.

**Theorem 16.** *There exists a  $\gamma$  value called  $\gamma_c$  for which the fully connected interference topology  $\mathcal{T}_c$  outperforms any other interference topology  $\mathcal{T} \in \mathcal{P}$  in terms of the achievable rate for any  $\gamma \geq \gamma_c$  where  $\gamma_e \leq \gamma_c \leq \gamma_x$  and  $\gamma_x$  can be evaluated by solving the following*

$$\begin{aligned} R_{\mathcal{T}_c}^*(\gamma_x) &= \max_{d_{\mathcal{T}}, \alpha_{\mathcal{T}}, \beta_{\mathcal{T}}^*} R_{\mathcal{T}}^*(\gamma_x) \\ \text{s.t. } & d_{\mathcal{T}} \in [1/K, 1/2], \alpha_{\mathcal{T}} \in ]0, 1], \beta_{\mathcal{T}}^* \in ]0, \beta_m]. \end{aligned} \quad (4.31)$$

**Theorem 17.** *There exists a  $\gamma$  value called  $\gamma_d$  for which the fully disconnected interference topology  $\mathcal{T}_d$  outperforms any other interference topology  $\mathcal{T} \in \mathcal{P}$  in terms of the achievable rate for any  $\gamma \leq \gamma_d$  where  $\gamma_y \leq \gamma_d \leq \gamma_e$  and  $\gamma_y$  can be evaluated by solving the following*

$$R_{\mathcal{T}_d}^*(\gamma_y) = \max_{d_{\mathcal{T}}, \alpha_{\mathcal{T}}, \beta_{\mathcal{T}}^*} R_{\mathcal{T}}^*(\gamma_y) \quad (4.32)$$

s.t.  $d_{\mathcal{T}} \in [1/K, 1/2], \alpha_{\mathcal{T}} \in ]0, 1], \beta_{\mathcal{T}}^* \in ]0, \beta_m[.$

The following theorem states when an intermediate interference topology  $\mathcal{T} \in \mathcal{P}$  outperforms the extreme interference topologies in terms of the achievable symmetric rate.

**Theorem 18.** *An intermediate topology  $\mathcal{T} \in \mathcal{P}$  outperforms in terms of the achievable rate the extreme interference topologies if and only if  $\gamma_{\mathcal{T}}^- < \gamma < \gamma_{\mathcal{T}}^+$  where  $\gamma_{\mathcal{T}}^-$  and  $\gamma_{\mathcal{T}}^+$  can be evaluated by solving the following*

$$R_{\mathcal{T}_d}^*(\gamma_{\mathcal{T}}^-) = R_{\mathcal{T}}^*(\gamma_{\mathcal{T}}^-), \quad (4.33)$$

$$R_{\mathcal{T}_c}^*(\gamma_{\mathcal{T}}^+) = R_{\mathcal{T}}^*(\gamma_{\mathcal{T}}^+). \quad (4.34)$$

## 4.6 Fundamental Limits on $\beta_{\mathcal{T}}^*$ for Interference Topologies with Half-DoF-Feasibility

In this section, we will present  $\beta_{\mathcal{T}}^*$  bounds that are able to specify, in the TIM problem of a wireless network, which *half-DoF-feasible* interference topologies will outperform, in terms of the achievable symmetric rate, the two extreme interference topologies.

We define the half-DoF-feasible interference topologies as follows.

**Definition 30** (Half-DoF-Feasible Interference Topologies). *An interference topology  $\mathcal{T}$  that can support in the TIM problem a symmetric DoF equal to 0.5 per message  $W_k \in \mathcal{W}$ , is called a half-DoF-feasible interference topology.*

In [1], Jafar showed that 0.5 is the maximal symmetric DoF per message  $W_k \in \mathcal{W}$  except if the interference topology is fully disconnected. To achieve 0.5 DoF per message, an IA approach may be required. The set of all half-DoF-feasible interference topologies associated to the given wireless network is denoted as  $\mathcal{H}$ . It is also known, from [1], that for any interference topology belonging to  $\mathcal{H}$ , a 0.25 DoF per message  $W_k \in \mathcal{W}$  at least, is achievable with orthogonal sharing. More precisely, the symmetric DoF per message  $W_k \in \mathcal{W}$  that is achievable with an orthogonal sharing, for any  $\mathcal{T} \in \mathcal{H}$ , belongs to  $\{1/2, 1/3, 1/4\}$ . Therefore, the topologies in  $\mathcal{H}$  can be categorized into three sets noted  $\mathcal{H}_{OS,1/2}, \mathcal{H}_{OS,1/3}, \mathcal{H}_{OS,1/4}$ .

**Definition 31** (Orthogonal DoF Solutions Based Half-DoF-Feasible Interference Topologies). *Any interference topology  $\mathcal{T} \in \mathcal{H}$  is categorized also in  $\mathcal{H}_{OS,1/L}$ , i.e.,  $\mathcal{T} \in \mathcal{H}_{OS,1/L}$ , where  $L \in \{2, 3, 4\}$ , if and only if the maximal DoF that can be achieved by each message  $W_k \in \mathcal{W}$  through orthogonal sharing is  $1/L$ . The sets  $\mathcal{H}_{OS,1/L}$  verify  $\mathcal{H} = \cup_{L \in \{2,3,4\}} \mathcal{H}_{OS,1/L}$  and  $\mathcal{H}_{OS,1/L} \cap \mathcal{H}_{OS,1/L'} = \emptyset$ , where  $L' \in \{2, 3, 4\}$  and  $L \neq L'$ .*

A half-DoF-feasible interference topology  $\mathcal{T} \in \mathcal{H}$  will outperform, in terms of the achievable symmetric rate, both extreme topologies,  $\mathcal{T}_c$  and  $\mathcal{T}_d$ , at some  $\gamma$ , under a condition on  $\beta_{\mathcal{T}}^*$ . Conversely, for a given  $\gamma$ , there is a specific  $\beta_{\mathcal{T}}^*$  range for which any interference topology  $\mathcal{T} \in \mathcal{H}$  with  $\beta_{\mathcal{T}}^*$  value within this  $\beta_{\mathcal{T}}^*$  range will outperform in terms of the achievable symmetric rate

the extreme interference topologies, and any interference topology  $\mathcal{T} \in \mathcal{H}$  with  $\beta_{\mathcal{T}}^*$  value not within this  $\beta_{\mathcal{T}}^*$  range will be outperformed in terms of the achievable symmetric rate by the extreme interference topologies.

Specifying this  $\beta_{\mathcal{T}}^*$  range, for a given  $\gamma$ , will be very helpful in avoiding an exhaustive search over the full  $\beta_{\mathcal{T}}^*$  range, i.e., the range  $[0, \beta_m]$ , to specify the half-DoF-feasible interference topologies in  $\mathcal{H}$  that are outperforming in terms of the achievable symmetric rate the extreme interference topologies. In other words, this  $\beta_{\mathcal{T}}^*$  range limits the search (for example, in an algorithm) to find half-DoF-feasible interference topology  $\mathcal{T}$  that can be the best topology at a given  $\gamma$ .

In the following, we will present the  $\beta_{\mathcal{T}}^*$  range, at a given  $\gamma$ , for which an interference topology  $\mathcal{T} \in \mathcal{H}$  will outperform, at the given  $\gamma$ , the extreme interference topologies in terms of the achievable symmetric rate if and only if  $\beta_{\mathcal{T}}^*$  is within this  $\beta_{\mathcal{T}}^*$  range. We will present this  $\beta_{\mathcal{T}}^*$  range for the half-DoF-feasible interference topologies when orthogonal sharing is used, i.e., for the three topology categories  $\mathcal{H}_{OS,1/L}$ ,  $L \in \{2, 3, 4\}$  and when IA is used, i.e., for any  $\mathcal{T} \in \mathcal{H}$ .

**Theorem 19** ( $\beta_{\mathcal{T}}^*$  Outer Bound: Orthogonal DoF Solutions Based Half-DoF-Feasible Interference Topologies). *For a given  $\gamma$ , a half-DoF-feasible interference topology  $\mathcal{T} \in \mathcal{H}_{OS,1/L}$ ,  $L \in \{2, 3, 4\}$ , when orthogonal sharing is used, outperforms the extreme interference topologies in terms of the achievable rate if and only if  $\beta_{\mathcal{T}}^* < B_L(\gamma)$  where  $B_L(\gamma)$  is defined as*

$$B_L(\gamma) = \frac{1}{2^{L \cdot R_E(\gamma)} - 1} - \frac{1}{\gamma}. \quad (4.35)$$

*Proof.* The result in (4.35) follows naturally from (5.20), for the case of a half-DoF-feasible interference topology  $\mathcal{T}$  when orthogonal sharing is used, i.e.,  $\mathcal{T} \in \mathcal{H}_{OS,1/L}$ , where  $d_{\mathcal{T}} = 1/L$  and  $\alpha_{\mathcal{T}} = 1$ , and from (4.26) and (4.27) which represent the achievable symmetric rates of the extreme interference topologies.  $\square$

**Theorem 20** ( $\beta_{\mathcal{T}}^*$  Outer Bound: IA DoF Solution Based Half-DoF-Feasible Interference Topologies). *For a given  $\gamma$ , a half-DoF-feasible interference topology  $\mathcal{T} \in \mathcal{H}$ , when IA is used, outperforms the extreme interference topologies in terms of the achievable rate if and only if  $\beta_{\mathcal{T}}^* < B_H(\gamma)$  where  $B_H(\gamma)$  is defined as*

$$B_H(\gamma) = \frac{\sin^2\left(\frac{\pi}{N_a}\right)}{2^{2 \cdot R_E(\gamma)} - 1} - \frac{1}{\gamma}, \quad (4.36)$$

where  $N_a$  is the number of alignment sets when non-conflicting alignment sets are merged into one alignment set [1].

*Proof.* The result in (4.36) follows naturally from (5.20), for the case of a half-DoF-feasible interference topology  $\mathcal{T}$  when IA is used, i.e.,  $\mathcal{T} \in \mathcal{H}$ , where  $d_{\mathcal{T}} = 0.5$  and  $\alpha_{\mathcal{T}} = \sin^2\left(\frac{\pi}{N_a}\right)$ , where  $N_a$  is the number of alignment sets when non-conflicting alignment sets are merged into one alignment set [1], and from (4.26) and (4.27) which represent the achievable symmetric rates of the extreme interference topologies.  $\square$

To illustrate the results in Theorems 19 and 20, we graphed the outer bounds of  $\beta_{\mathcal{T}}^*$ , for  $K = 10$  and with  $N_a = 3$ , as a function of  $\gamma$ , for the orthogonal and the IA cases, in Figure 4.3 and Figure 4.4, respectively. In Figure 4.3, where  $L = 3$ , we know that, for a given  $\gamma$ , there

exists many half-DoF-feasible interference topologies throughout the range  $[0, \beta_m]$ . However, from Theorem 19, we know that a half-DoF-feasible interference topology  $\mathcal{T} \in \mathcal{H}_{\text{OS},1/L}$  will outperform the extreme interference topologies if and only if  $\beta_{\mathcal{T}}^*$  is within the range  $[0, B_L(\gamma)]$ . This greatly reduces the search range for the half-DoF-feasible interference topologies from the full  $\beta_{\mathcal{T}}^*$  range, i.e.  $[0, \beta_m]$ , to the range  $[0, B_L(\gamma)]$ . Since this search involves looking at a huge number of combinations of possible interference topologies for each  $\beta_m$  value, the reduction is of great importance in optimizing the algorithmic complexity. The same conclusion holds for the IA case in Figure 4.4.

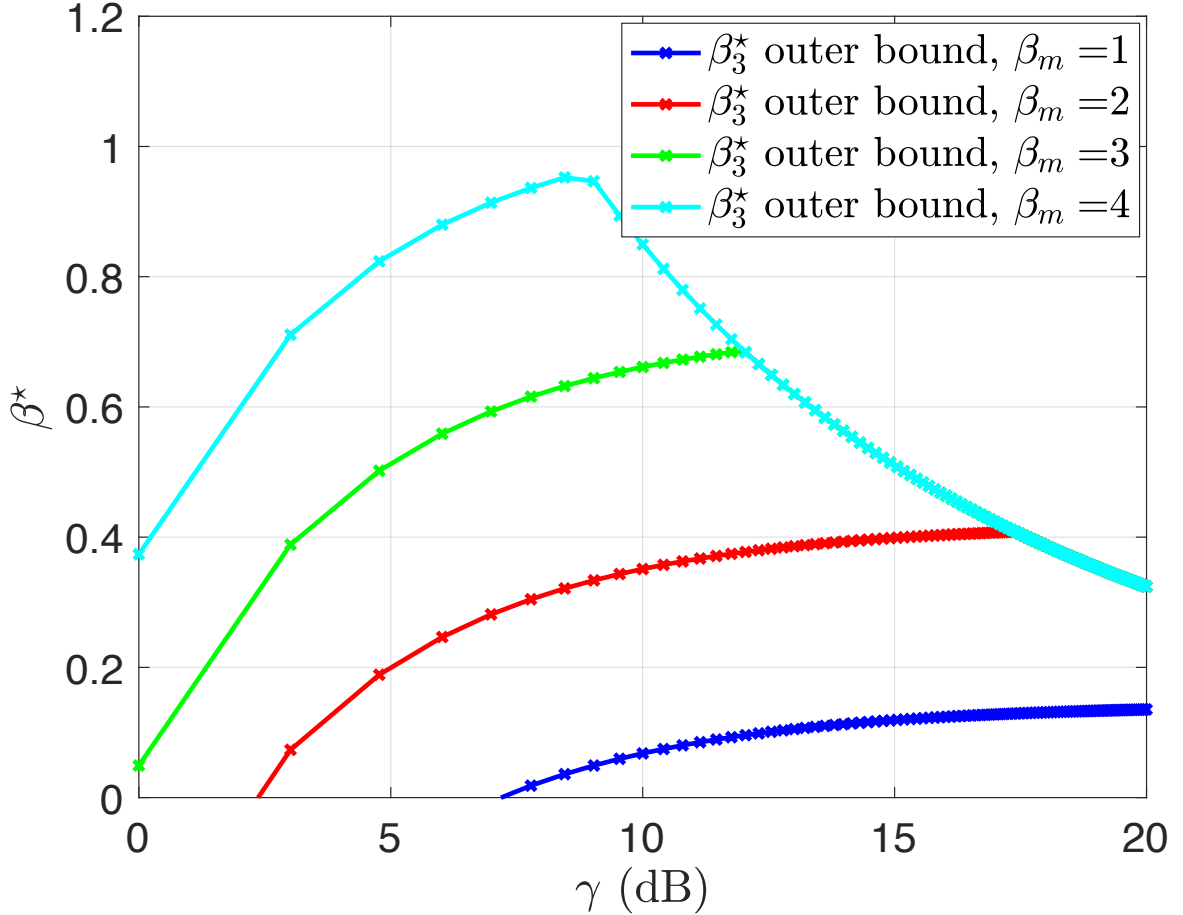

Figure 4.3:  $\beta_3^*$  outer bounds for different  $\beta_m$  values. (We refer in this figure to the  $\beta_{\mathcal{T}}^*$  outer bound, defined in theorem 19, by  $\beta_3^*$ ).

## 4.7 Conclusion

In this chapter, we have introduced a new approach to convert a wireless network into a TIM model using a normalized interference threshold  $\beta$  that ensures the validity of the interference topology for all SNRs. Based on this approach, the TIM analysis exhibits the fundamental trade-off between DoF and SINR maximization. This contribution is complementary to classical work related to TIM since the focus is clearly on the formulation of a TIM problem.



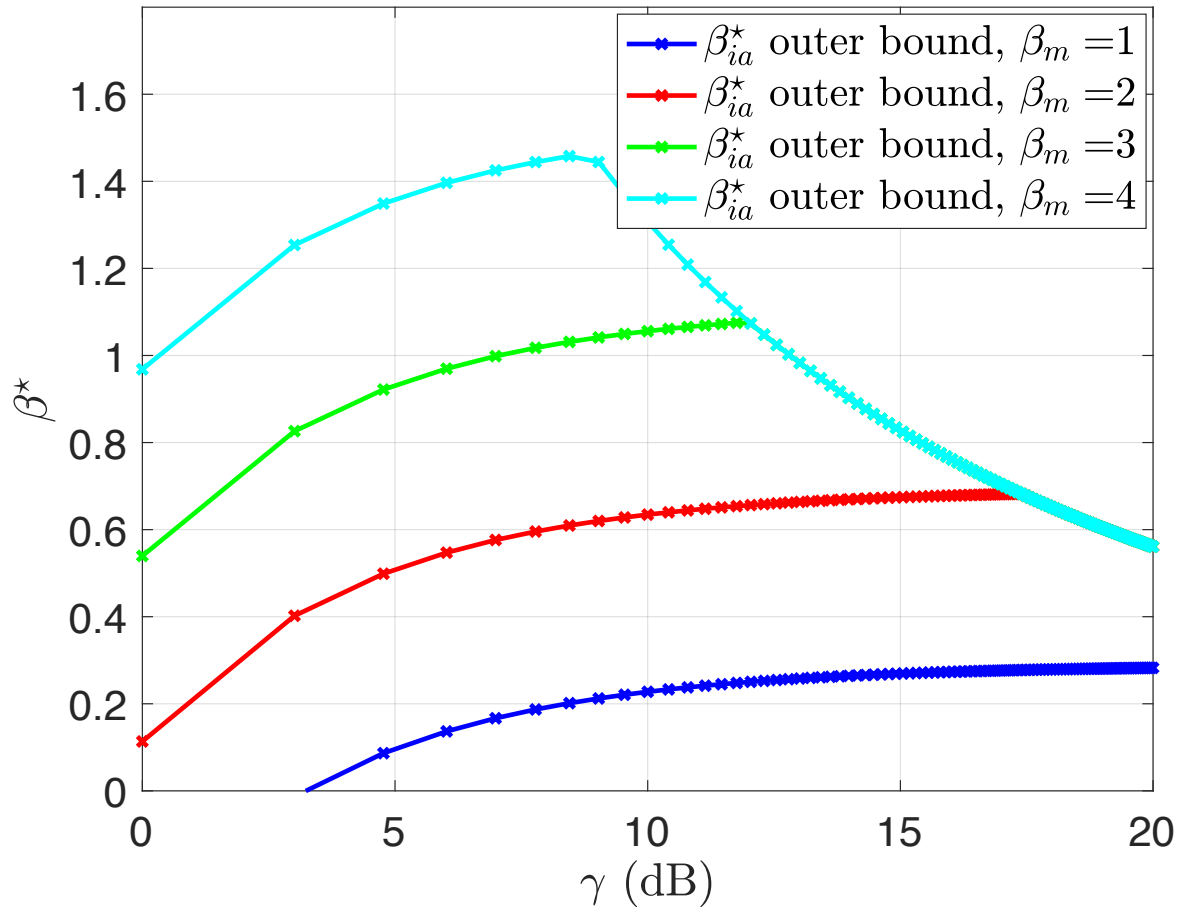

Figure 4.4:  $\beta_{ia}^*$  outer bounds for different  $\beta_m$  values and with  $N_a = 3$ . (We refer in this figure to the  $\beta_{\gamma}^*$  outer bound, defined in theorem 20, by  $\beta_{ia}^*$ ).

This approach provides a better evaluation of the achievable symmetric rate of the initial wireless network.

# — 5 —

---

## TIM for Small Scale Wireless Networks: Four Users Networks

This chapter considers the TIM problem for small-scale wireless networks (four users wireless networks) using the interference topology construction approach proposed in chapter 4. In this chapter, we apply the achievable rates analysis, proposed in chapter 4, for all interference topologies with half-DoF-feasibility in the TIM problem of four users wireless networks.

### 5.1 System Model

#### 5.1.1 Initial Network Model

Consider a wireless communication network consisting of 4 TXs, labeled,  $S_1, S_2, S_3, S_4$ , and 4 RXs, labeled,  $D_1, D_2, D_3, D_4$ . Let  $\mathcal{W} = \{W_1, W_2, W_3, W_4\}$  be the set of all messages to be transmitted in the network. We assume that the network supports unicast transmissions, where TX  $S_k$ ,  $k \in \{1, 2, 3, 4\}$ , sends a unique message  $W_k$  to a unique RX  $D_k$ . Each TX  $S_k$  uses a power  $P_k$  to transmit its unique message  $W_k$ , and each RX  $D_k$  is subject to interference from every TX  $S_{k'}, k' \in \{1, 2, 3, 4\}/\{k\}$ . The wireless network includes two kinds of communication links: the desired links, i.e., the links  $S_k \rightarrow D_k, \forall k \in \{1, 2, 3, 4\}$ , and the interference links, i.e., the links  $S_{k'} \rightarrow D_k, \forall k, k' \in \{1, 2, 3, 4\}$  and  $k' \neq k$ . The wireless network is shown in Fig. 5.1.

The channel input-output relationships are defined as

$$y_i(n) = \sum_{j=1}^4 h_{ij}x_j(n) + z_i(n), \quad (5.1)$$

where, over the  $n$ th channel use,  $x_j(n)$  is the transmitted symbol from message source  $S_j$ ,  $j \in \{1, 2, 3, 4\}$ ,  $y_i(n)$  is the received symbol at message destination  $D_i$ ,  $i \in \{1, 2, 3, 4\}$ ,  $z_i(n)$

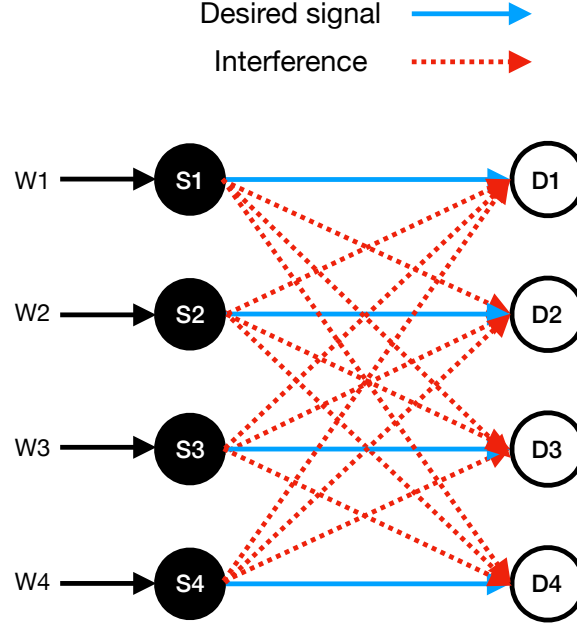

Figure 5.1: Wireless communication network with 4 users.

is the additive noise at message destination  $D_i$ , and  $h_{ij}$  is the constant channel coefficient between message source  $S_j$  and message destination  $D_i$ . All symbols belong to the field  $\mathbb{C}$ . We also denote  $g_{ij} = |h_{ij}|^2$ , the flat fading channel gain associated to each source-destination link. The term  $z_i(n)$  is the i.i.d. complex circularly symmetric additive white Gaussian noise term, with zero mean and variance  $N_0$ .

### 5.1.2 Normalized Network Model for TIM

We start by choosing the desired SNR target  $\gamma$ . We assume the network performs a power control to guarantee the same SNR target for all desired links  $S_j \rightarrow D_j$ . Hence, the transmission powers are fixed according to

$$P_j = \frac{N_0 \gamma}{g_{jj}}, \quad \forall j \in \{1, 2, 3, 4\}. \quad (5.2)$$

Let us formulate an equivalent system by scaling the transmission powers and the noise values such that:

1. The normalized noise power at each destination  $D_i$  is set to 1.
2. The normalized channel gains associated to the desired links are also set to  $\tilde{g}_{jj} = 1, \forall j \in \{1, 2, 3, 4\}$ .
3. The equivalent transmission powers are consequently set to  $P'_j = \gamma, \forall j \in \{1, 2, 3, 4\}$ .
4. The normalized interference channel gains are set to  $\tilde{g}_{ij} = \frac{g_{ij}}{g_{jj}}, \forall i, j \in \{1, 2, 3, 4\}$  and  $i \neq j$ .

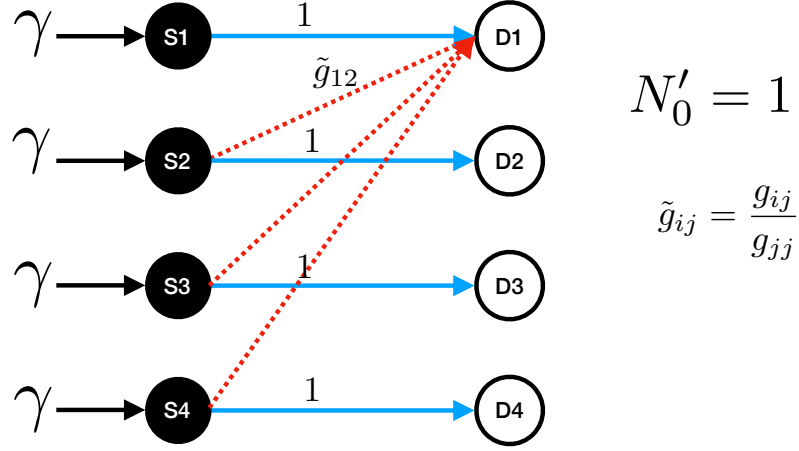
 Figure 5.2: Normalized network model with  $K = 4$ .

A normalized network model for the wireless communication network, in Fig. 5.1, with  $K = 4$ , is shown in Fig. 5.2. This model corresponds to a normalization of the standard TIM model defined in [1].

## 5.2 TIM: Interference Topology Formulation

### 5.2.1 SNR-Independent Interference Threshold

Based on the normalized model described in section 5.1.2, the transmission power from each message source  $S_j$  is  $\gamma$ , and the noise level at each message destination  $D_i$  is unitary. Let us turn our interest to the interference strength at message destination  $D_i$  which is now given by

$$I_i = \sum_{j=1; j \neq i}^4 \tilde{g}_{ij} \cdot \gamma, \quad (5.3)$$

and the SINR at  $D_i$  turns out to be

$$\xi_i = \frac{\gamma}{1 + \gamma \sum_{j=1; j \neq i}^4 \tilde{g}_{ij}}. \quad (5.4)$$

Let us consider a TIM problem  $\mathbf{TIM}(\mathcal{T})$  with an interference topology  $\mathcal{T}$  to be determined, and let us consider an arbitrary interference threshold  $\tau_{\mathcal{T}}$  at each message destination  $D_i$ . An interference topology  $\mathcal{T}$  can be determined in which for each destination  $D_i$ , the interference links set,  $\mathcal{I}_i = \{S_j \rightarrow D_i; j \in \{1, 2, 3, 4\}, j \neq i\}$ , is divided into two subsets, a set of significant interference links  $\mathcal{S}_{i,\mathcal{T}}$  and a set of weak interference links  $\bar{\mathcal{S}}_{i,\mathcal{T}}$ , in which  $\mathcal{I}_i = \mathcal{S}_{i,\mathcal{T}} \cup \bar{\mathcal{S}}_{i,\mathcal{T}}$  and  $\mathcal{S}_{i,\mathcal{T}} \cap \bar{\mathcal{S}}_{i,\mathcal{T}} = \emptyset$ . The weak interference links, associated to  $\bar{\mathcal{S}}_{i,\mathcal{T}}$ , at message destination  $D_i$ , will be neglected. In order to determine the interference topology  $\mathcal{T}$ , we choose the set  $\bar{\mathcal{S}}_{i,\mathcal{T}}$ , at each  $D_i$ , such that its elements sum interference verifies

$$\sum_{\{S_j \rightarrow D_i\} \in \bar{\mathcal{S}}_{i,\mathcal{T}}} \tilde{g}_{ij} \cdot \gamma \leq \tau_{\mathcal{T}}, \quad (5.5)$$

which can be rewritten as

$$\sum_{\{S_j \rightarrow D_i\} \in \bar{\mathcal{S}}_{i,\mathcal{T}}} \tilde{g}_{ij} \leq \beta_{\mathcal{T}}, \quad (5.6)$$

where  $\beta_{\mathcal{T}} = \frac{\tau_{\mathcal{T}}}{\gamma}$  is a normalized interference threshold that leads to the construction of the topology  $\mathcal{T}$ . Note that, a unique value for  $\beta_{\mathcal{T}}$  may lead to the construction of different interference topologies  $\mathcal{T}$ .

In (5.6), the left hand term relies only on the channel coefficients and not on  $\gamma$ . This means that an interference topology  $\mathcal{T}$  built for a given  $\beta_{\mathcal{T}}$  is valid for any couple  $(\gamma, \tau_{\mathcal{T}})$  such that  $\tau_{\mathcal{T}}/\gamma = \beta_{\mathcal{T}}$ . Finally, for each value of  $\beta_{\mathcal{T}}$ , a TIM instance (i.e., an interference topology  $\mathcal{T}$  in the TIM problem  $\mathbf{TIM}(\mathcal{T})$ ) can be built and evaluated for a full range of SNRs. Note that, while a given  $\beta_{\mathcal{T}}$  value corresponds to an interference topology  $\mathcal{T}$ , such a topology may be obtained through a range of  $\beta_{\mathcal{T}}$  values.

### 5.2.2 Fundamental Trade-off between DoF and SINR Maximization

Once an interference topology  $\mathcal{T}$  is determined based on constraints (5.2) and (5.6), the collective interference at  $D_i$  from the weak interference links in  $\bar{\mathcal{S}}_{i,\mathcal{T}}$  is upper bounded by  $\gamma\beta_{\mathcal{T}}$ , and the linear coding resource allocation process will guarantee a lower bound on the effective SINR at each  $D_i$ , given as

$$\xi_{i,\mathcal{T}} \geq \alpha_{\mathcal{T}} \frac{\gamma}{1 + \gamma\beta_{\mathcal{T}}}, \quad \forall i \in \{1, 2, 3, 4\}, \quad (5.7)$$

where  $\alpha_{\mathcal{T}}$  is the non-orthogonality loss factor.

According to [1], linear coding allows to increase the DoF by using non-orthogonal linear vectors, but in turns result in a degraded SINR due to the non-orthogonal linear coding penalty factor  $\alpha_{\mathcal{T}}$ . This penalty comes from the fact that the receiver has to project the received signal in the interference-free subspace [3]. Therefore, the following engineering tradeoff holds: either the resource allocation is restricted to an orthogonal allocation strategy providing a maximal SINR value, i.e.,  $\frac{\gamma}{1 + \gamma\beta_{\mathcal{T}}}$ , at each message destination, at the price however of a limited DoF, or the resource allocation can exploit a linear coding strategy, which usually increases the DoF, at the price of reduced individual SINRs.

In our model, when  $\gamma$  tends to infinity, the SINR  $\xi_{i,\mathcal{T}}$  is not infinite as in Jafar's model [1], but is bounded by  $\frac{\alpha_{\mathcal{T}}}{\beta_{\mathcal{T}}}$ ,  $\forall i \in \{1, 2, 3, 4\}$ , which fits better with the properties of the real wireless network behind the interference topology model. Consequently, the DoF analysis does not provide the slope of an infinite capacity in the high SNR regime, but rather a maximal capacity. The only solution to get an infinite capacity is to use an orthogonal resource sharing between all pairs of nodes.

## 5.3 Achievable Rates under the Interference Topology Formulation

In this section, we are going to characterize an achievable symmetric rate per message  $W_k \in \mathcal{W}$  of the wireless network defined in section 5.1.1. First, let us denote by  $\mathcal{P}$  the set of all possible interference topologies of the wireless network.

For a TIM problem  $\mathbf{TIM}(\mathcal{T})$  with an interference topology  $\mathcal{T}$ , we can characterize an achievable symmetric rate per message, i.e., a rate  $R_{\mathcal{T}}(\gamma)$  that can be achieved by each

message  $W_k \in \mathcal{W}$  through linear coding, as follows

$$R_{\mathcal{T}}(\gamma) = d_{\mathcal{T}} \cdot \log_2 \left( 1 + \frac{\alpha_{\mathcal{T}} \gamma}{1 + \gamma \beta_{\mathcal{T}}} \right), \quad (5.8)$$

where  $d_{\mathcal{T}}$  is the symmetric DoF per message, i.e., the maximal DoF that can be achieved by each message  $W_k \in \mathcal{W}$  in the TIM problem  $\mathbf{TIM}(\mathcal{T})$  through linear coding,  $\alpha_{\mathcal{T}}$  is the non-orthogonal linear coding penalty factor that leads to the symmetric DoF solution  $d_{\mathcal{T}}$  in the TIM problem  $\mathbf{TIM}(\mathcal{T})$ .

We recall that a range of values of  $\beta_{\mathcal{T}}$  may lead to the construction of the same interference topology  $\mathcal{T}$ . We are interested in finding the  $\beta_{\mathcal{T}}$  value, out of all the possible  $\beta_{\mathcal{T}}$  values that lead to the construction of this interference topology  $\mathcal{T}$ , that provides the highest achievable symmetric rate in (5.8) for the same  $d_{\mathcal{T}}$  (fixed interference topology  $\mathcal{T}$ ). This is going to be stated in the following definitions.

**Definition 32** (Lowest  $\beta$  Value for  $\mathcal{T}$ ). *The lowest  $\beta$  value that leads to the construction of an interference topology  $\mathcal{T}$  is defined as*

$$\beta_{\mathcal{T}}^* = \max_i \sum_{\{S_j \rightarrow D_i\} \in \tilde{\mathcal{S}}_{i,\mathcal{T}}} \tilde{g}_{ij}. \quad (5.9)$$

**Definition 33** (Achievable Symmetric Rate: Finite SNR Regime). *An achievable symmetric rate, in the finite SNR regime, through linear coding schemes, of a wireless network can be defined as the highest achievable symmetric rate among the achievable symmetric rates associated to all TIM problems of all possible interference topologies of the wireless network, as follows*

$$R_{\mathcal{W}}(\gamma) = \max_{\mathcal{T} \in \mathcal{P}} R_{\mathcal{T}}^*(\gamma), \quad (5.10)$$

where  $R_{\mathcal{T}}^*(\gamma)$  is the achievable symmetric rate associated to the TIM problem  $\mathbf{TIM}(\mathcal{T})$ , defined as

$$R_{\mathcal{T}}^*(\gamma) = d_{\mathcal{T}} \cdot \log_2 \left( 1 + \frac{\alpha_{\mathcal{T}} \gamma}{1 + \gamma \beta_{\mathcal{T}}^*} \right). \quad (5.11)$$

## 5.4 Interference Topology Graph and Conflict Graph of the 4 Users Unicast TIM Problem

Let us define the interference topology graph and the conflict graph of the 4 users unicast TIM problem as follows.

**Definition 34** (4 Users Interference Topology Graph). *The interference topology graph of a 4 users unicast TIM instance is a bidirected graph with 4 vertices, where each vertex represents a unique message from the set of all messages  $\mathcal{W}$  and a directed edge from the vertex that representing message  $W_j$  to the vertex that representing message  $W_i$ ,  $i \neq j$ , exists only if destination  $D_i$  is corrupted by source  $S_j$ , i.e.,  $\{S_j \rightarrow D_i\} \in \mathcal{S}_i$ .*

**Definition 35** (4 Users Conflict Graph). *The conflict graph of a 4 users unicast TIM instance is an undirected graph with 4 vertices, where each vertex represents a unique message from the set of all messages  $\mathcal{W}$  and an edge between the vertices that representing the messages  $W_i$  and  $W_j$ ,  $i \neq j$ , exists only if either destination  $D_i$  is corrupted by source  $S_j$ , i.e.,  $\{S_j \rightarrow D_i\} \in \mathcal{S}_i$ , or destination  $D_j$  is corrupted by source  $S_i$ , i.e.,  $\{S_i \rightarrow D_j\} \in \mathcal{S}_j$ .*

We consider a one possible TIM instance, of the initial wireless network shown in Fig. 5.1, such that the weak interference links are given as,  $\bar{\mathcal{S}}_1 = \{S_3 \rightarrow D_1\}$ ,  $\bar{\mathcal{S}}_2 = \{S_3 \rightarrow D_2\}$ ,  $\bar{\mathcal{S}}_3 = \{S_1 \rightarrow D_3, S_4 \rightarrow D_3\}$ , and  $\bar{\mathcal{S}}_4 = \{S_1 \rightarrow D_4, S_2 \rightarrow D_4, S_3 \rightarrow D_4\}$ . The interference topology graph and the conflict graph of this possible TIM instance are shown in Fig. 5.3.

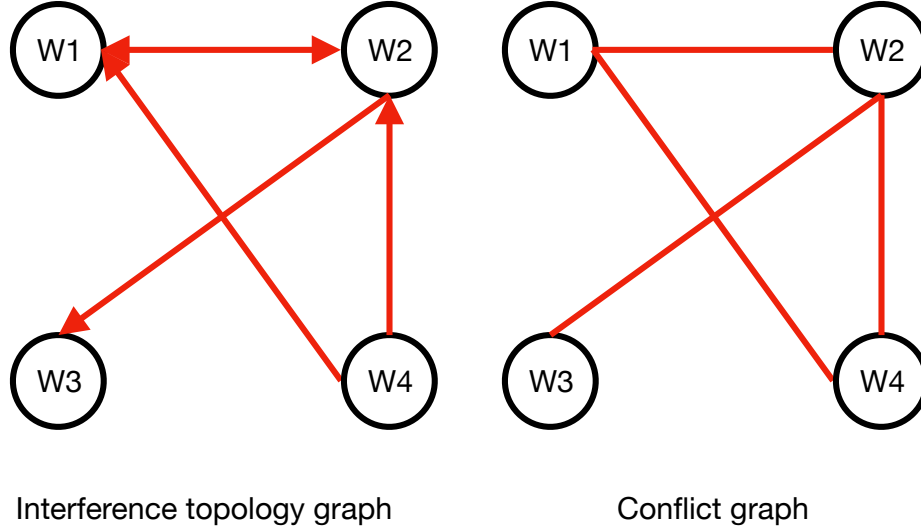

Figure 5.3: The interference topology graph and the conflict graph of a 4 users unicast TIM instance.

Each possible TIM instance has a unique interference topology graph representation, while different possible TIM instances, i.e., different possible interference topologies' graphs can correspond to a unique conflict graph. A different possible interference topologies' graphs can correspond to a unique conflict graph if and only if they have the same underlying graph which is the same unique conflict graph. The underlying graphs of the different possible interference topologies graphs come by replacing the directed edges in these graphs with undirected edges. We will consider the conflict graph representation as a starting step in the TIM analysis.

An unlabeled conflict graph is a conflict graph without labeling the vertices of the conflict graph by the messages from the set of all messages  $\mathcal{W}$ . We define this graph representation as follows.

**Definition 36** (4 Users Unlabeled Conflict Graph  $C_u$ ). *An unlabeled conflict graph  $C_u$  of a 4 users unicast TIM instance,  $u \in N_u$ , where  $N_u = 11$  is the number of all possible unlabeled conflict graphs, is an undirected graph with 4 unlabeled vertices, i.e., 4 virtual labeled vertices  $w, x, y, z \in \{W_1, W_2, W_3, W_4\}$  and  $w \neq x \neq y \neq z$ . Each unlabeled conflict graph  $C_u$  is characterized by two subsets  $\mathcal{V}_u$  and  $\mathcal{G}_u$ , where  $\mathcal{V}_u = \{d_w, d_x, d_y, d_z\}$ , and  $d_w, d_x, d_y, d_z$  are the vertices' degrees of the 4 virtual labeled vertices  $w, x, y, z$ , and  $\mathcal{G}_u = \{\mathcal{B}_w, \mathcal{B}_x, \mathcal{B}_y, \mathcal{B}_z\}$ , where  $\mathcal{B}_w, \mathcal{B}_x, \mathcal{B}_y, \mathcal{B}_z$  is the set of the vertices' degrees of the adjacent vertices of the vertices  $w, x, y, z$  respectively. Each unlabeled conflict graph  $C_u$  is also characterized with a unique edges set  $\mathcal{E}_u$ .*

Each conflict graph has its unlabeled conflict graph representation. Also, we can notice that different conflict graphs can have the same unlabeled conflict graph representation. (i.e., different conflict graphs can correspond to a unique unlabeled conflict graph representation).

All possible unlabeled conflict graphs, of all possible TIM instances of the initial wireless network shown in Fig. 5.1, are shown in Figure 5.4.

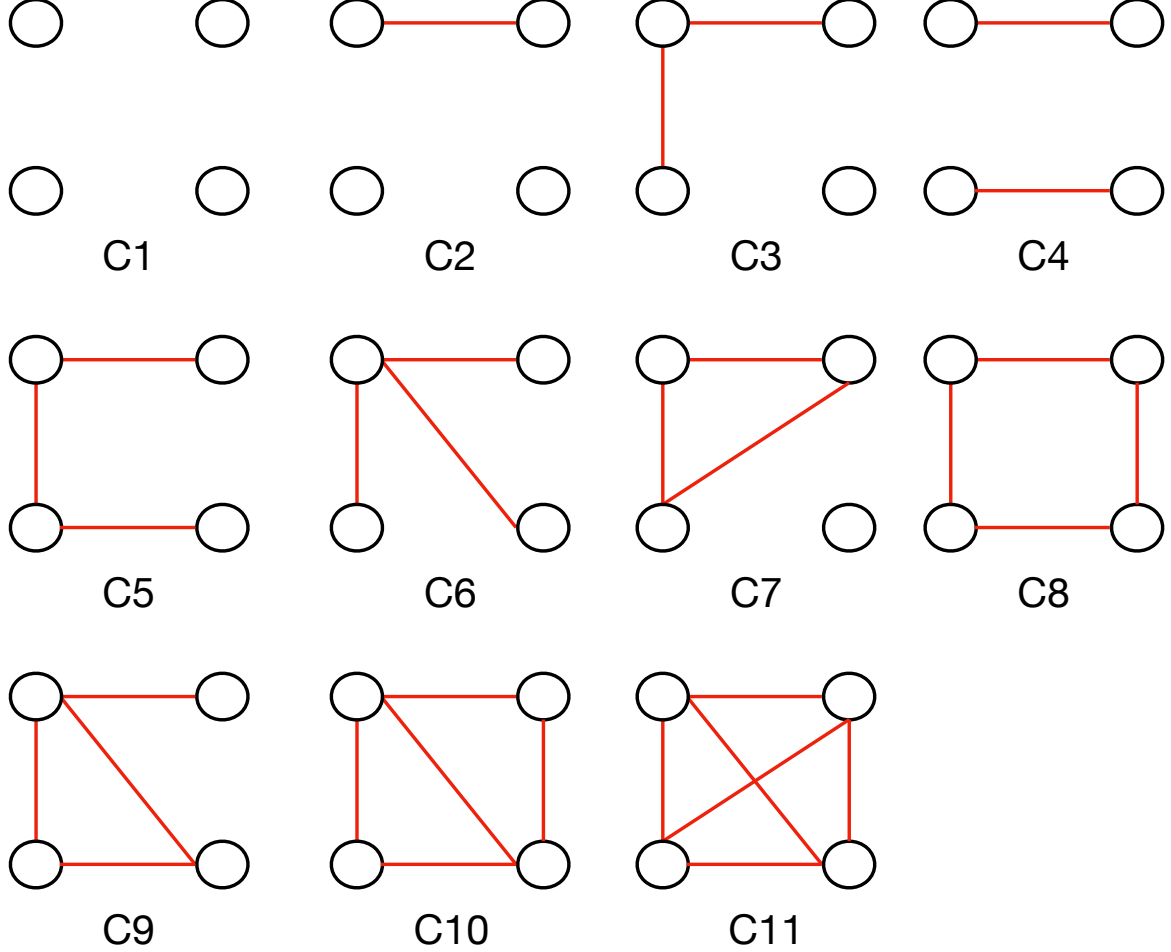

Figure 5.4: All possible unlabeled conflict graphs.

The unlabelled conflict graph  $C_9$  is characterized by the two subsets  $\mathcal{V}_9$  and  $\mathcal{G}_9$ , where  $\mathcal{V}_9 = \{3, 1, 2, 2\}$  and  $\mathcal{G}_9 = \{\{1, 2, 2\}, \{3\}, \{3, 2\}, \{3, 2\}\}$ .

Now, let us define the following unlabeled conflict graphs' domination law.

**Definition 37** (Domination Law for Unlabeled Conflict Graphs). *An unlabeled conflict graph  $C_u$  characterized with the unique edges set  $\mathcal{E}_u$ , dominates an unlabeled conflict graph  $C_v$  characterized with the unique edges set  $\mathcal{E}_v$ , i.e.,  $C_u \rightarrow C_v$ , if and only if  $\mathcal{E}_v \subset \mathcal{E}_u$ .*

**Property 3** (Domination Law for Unlabeled Conflict Graphs). *If an unlabeled conflict graph  $C_u$  dominates an unlabeled conflict graph  $C_v$ , i.e.,  $C_u \rightarrow C_v$ , and the unlabeled conflict graph  $C_v$  dominates an unlabeled conflict graph  $C_w$ , i.e.,  $C_v \rightarrow C_w$ , then  $C_u$  dominates  $C_w$ , i.e.,  $C_u \rightarrow C_w$ .*

Fig. 5.5 shows the dominations of the unlabeled conflict graphs shown in Fig. 5.4.



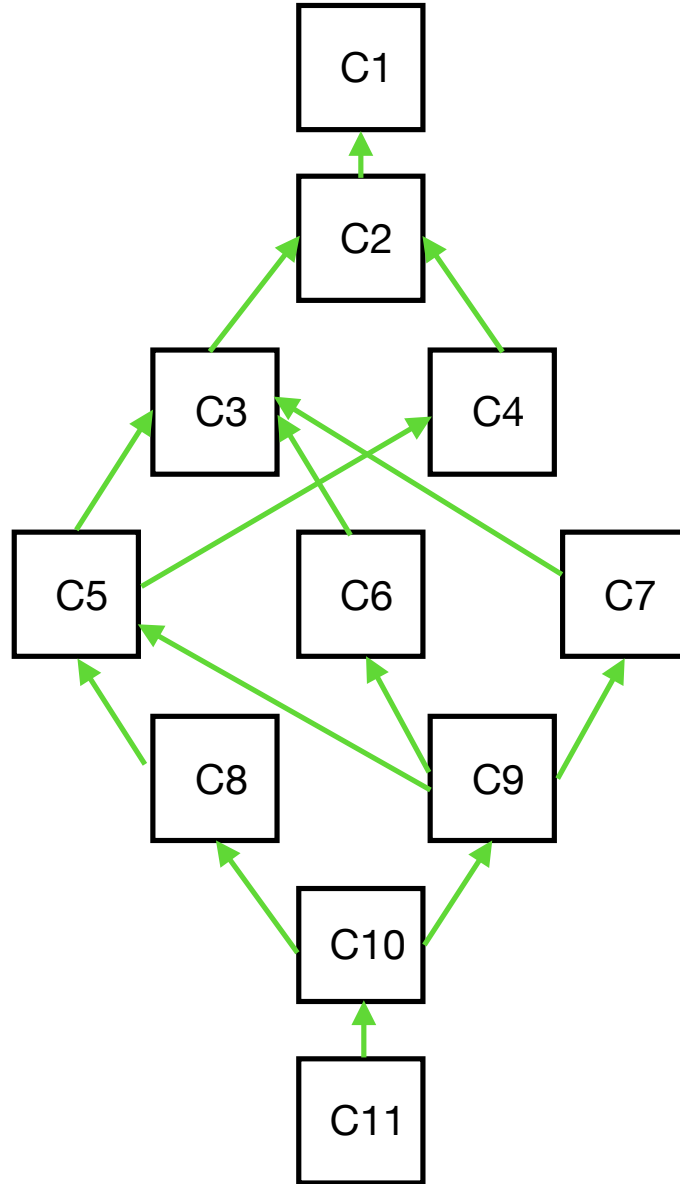

Figure 5.5: Unlabelled conflict graphs dominations.

## 5.5 Half-DoF Through Orthogonal Sharing

Let us define the orthogonal sharing *half-DoF* interference topologies as follows.

**Definition 38** (Orthogonal Sharing Half-DoF Interference Topologies). *An interference topology  $\mathcal{T}$  that can support in the TIM problem a symmetric DoF equal to 0.5 per message  $W_k \in \mathcal{W}$ , through orthogonal sharing scheme, is called an orthogonal sharing half-DoF interference topology.*

It is also known, from [1], that for any interference topology  $\mathcal{T}$ , a 0.5 symmetric DoF per message  $W_k \in \mathcal{W}$ , is achievable with orthogonal sharing under a sufficient and necessary

condition on the associated conflict graph of the interference topology.

**Theorem 21** (Orthogonal Sharing Half-DoF Interference Topologies). *An interference topology  $\mathcal{T}$  has a symmetric DoF equal to 0.5 per message  $W_k \in \mathcal{W}$ , through orthogonal sharing, if and only if the corresponding unlabeled conflict graph of the interference topology  $\mathcal{T}$  has no clique of size 3 or more.*

An unlabeled conflict graph that has no clique of size 3 or more is called an orthogonal sharing Half-DoF unlabeled conflict graph.

**Definition 39** (Undominated Unlabeled Conflict Graph of Orthogonal Sharing Half-DoF Interference Topologies). *An unlabeled conflict graph  $C_u$ , is an undominated unlabeled conflict graph of orthogonal sharing Half-DoF interference topologies, and we call it undominated orthogonal sharing Half-DoF unlabeled conflict graph, if and only if  $C_u$  has no clique of size 3 or more and  $C_u$  is not dominated by any orthogonal sharing Half-DoF unlabeled conflict graph  $C_v$ ,  $\forall v \neq u$ .*

For the 4 users unicast TIM problem, we have, from the unlabeled conflict graphs shown in Fig. 5.4, two undominated orthogonal sharing Half-DoF unlabeled conflict graphs,  $C_6$  and  $C_8$ . These two graphs are shown in Fig 5.6.

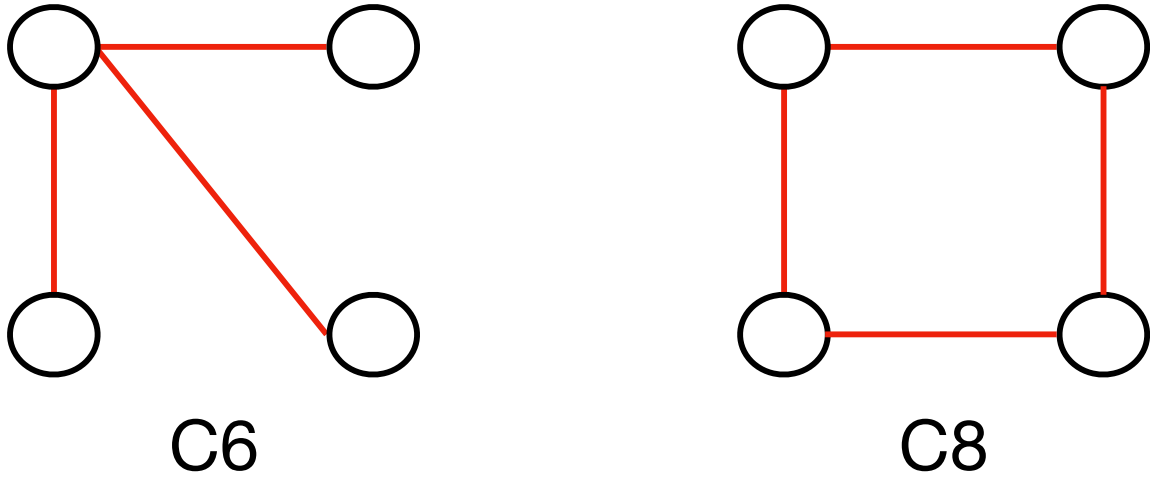

Figure 5.6: Undominated orthogonal sharing Half-DoF unlabeled conflict graphs.

**Theorem 22** (Achievable Symmetric Rate Through Orthogonal Sharing Half-DoF Solutions). *An achievable symmetric rate, through orthogonal sharing schemes, of the wireless network, when Half-DoF solutions are considered, can be defined as the highest achievable symmetric rate among the achievable symmetric rates associated to all possible interference topologies that have undominated orthogonal sharing Half-DoF unlabeled conflict graphs.*

Now, let us define the bi-directed interference topology of an unlabeled conflict graph, as follows

**Definition 40** (4 Users Bi-directed Interference Topology of An Unlabeled Conflict Graph). *The bi-directed interference topology of an unlabeled conflict graph is an unlabeled interference*

topology with 4 unlabeled vertices, i.e., 4 virtual labeled vertices  $w, x, y, z \in \{W_1, W_2, W_3, W_4\}$  and  $w \neq x \neq y \neq z$ , and it can be constructed by considering each undirected edge in the unlabeled conflict graph as a bidirected edge.

The bi-directed interference topologies of the undominated orthogonal sharing Half-DoF unlabeled conflict graphs  $C_6$  and  $C_8$ , are shown in Fig. 5.7.

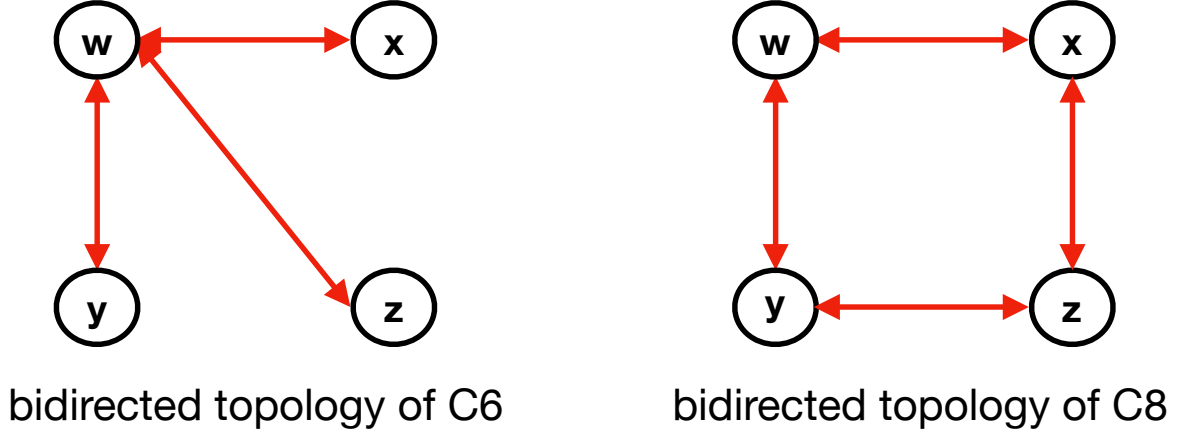

Figure 5.7: The bi-directed interference topologies of the undominated orthogonal sharing Half-DoF unlabeled conflict graphs  $C_6$  and  $C_8$ .

**Definition 41** (Achievable Symmetric Rate Through Orthogonal Sharing Half-DoF Solutions). *To characterize an achievable symmetric rate, through undominated orthogonal sharing Half-DoF unlabeled conflict graphs, it is sufficient to evaluate the SINR of the bi-directed interference topology of each undominated orthogonal sharing Half-DoF unlabeled conflict graph.*

The bi-directed interference topology of an undominated orthogonal sharing Half-DoF unlabeled conflict graph is called undominated orthogonal sharing Half-DoF bi-directed interference topology.

Since the 4 users bi-directed interference topology is an unlabelled interference topology with 4 unlabeled vertices, i.e., 4 virtual labeled vertices  $w, x, y, z \in \{W_1, W_2, W_3, W_4\}$  and  $w \neq x \neq y \neq z$ , then each bi-directed interference topology of an undominated orthogonal sharing Half-DoF unlabeled conflict graph corresponds to  $4!$  interference topologies by considering all unlabeled nodes' permutations.

Since we are interested in evaluating the SINR of the bi-directed interference topology of each undominated orthogonal sharing Half-DoF unlabeled conflict graph, and by considering the symmetric graph representation, in Fig. 5.7, for the bi-directed interference topology of  $C_6$  and for the bi-directed interference topology of  $C_8$ , then there is no need to consider all  $4!$  interference topologies of each bi-directed interference topology of an undominated orthogonal sharing Half-DoF unlabeled conflict graph, and it is sufficient to consider only the distinct labelings of the bi-directed interference topologies of  $C_6$  and  $C_8$ . The symmetric graph representation can be seen by considering the automorphism of the graph.

**Definition 42** (Automorphism of a Graph). *An automorphism of a graph is a permutation of its vertices that preserves the graph edges' adjacency.*

**Property 4** (Automorphism of a Graph). *For a given unlabelled simple graph with  $K$  vertices,  $K!/aut$  is the number of distinct labelings of this graph where  $aut$  is the number of all automorphisms of the graph.*

For the bi-directed interference topology of  $C_6$ , the number of all automorphisms is  $aut = 6$ , then we have 4 distinct labelings of the bi-directed interference topology of  $C_6$ . While, for the bi-directed interference topology of  $C_8$ , the number of all automorphisms is  $aut = 8$ , then we have 3 distinct labelings of the bi-directed interference topology of  $C_8$ .

To evaluate the maximal SINR, through orthogonal sharing schemes, of the wireless network, when Half-DoF solutions are considered, we consider the complement graphs of the bi-directed interference topologies of the undominated orthogonal sharing Half-DoF unlabeled conflict graphs  $C_6$  and  $C_8$ , as shown in Fig. 5.8.

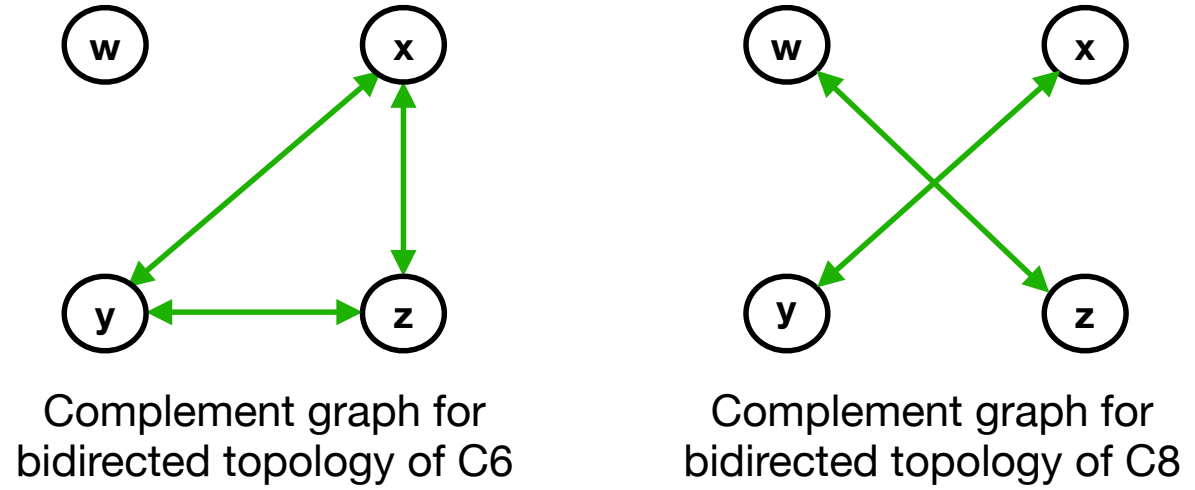

Figure 5.8: Complement graphs of the bi-directed interference topologies of the undominated orthogonal sharing Half-DoF unlabeled conflict graphs  $C_6$  and  $C_8$ .

The maximal SINR that can be evaluated through the bi-directed interference topology of the undominated orthogonal sharing Half-DoF unlabeled conflict graph  $C_6$ , is defined as

$$\eta_{C_6}^* = \frac{\gamma}{1 + \gamma\beta_{C_6}^{**}}, \quad (5.12)$$

where  $\beta_{C_6}^{**}$  is the minimal value among the 4  $\beta_{\mathcal{T}}^*$  values that correspond to the 4 distinct labelings of the bi-directed interference topology of  $C_6$ , and  $\beta_{C_6}^{**}$  can be evaluated through the complement graph of the bi-directed interference topology of the undominated orthogonal sharing Half-DoF unlabeled conflict graph  $C_6$  shown in Fig. 5.8.

The maximal SINR that can be evaluated through the bi-directed interference topology of the undominated orthogonal sharing Half-DoF unlabeled conflict graph  $C_8$ , is defined as

$$\eta_{C_8}^* = \frac{\gamma}{1 + \gamma\beta_{C_8}^{**}}, \quad (5.13)$$

where  $\beta_{C_8}^{**}$  is the minimal value among the 3  $\beta_{\mathcal{T}}^*$  values that correspond to the 3 distinct labelings of the bi-directed interference topology of  $C_8$ , and  $\beta_{C_8}^{**}$  can be evaluated through the

complement graph of the bi-directed interference topology of the undominated orthogonal sharing Half-DoF unlabeled conflict graph  $C_8$  shown in Fig. 5.8.

Then, the maximal SINR that can be evaluated, through orthogonal sharing schemes, of the wireless network, when Half-DoF solutions are considered, is defined as

$$\eta^{**} = \max(\eta_{C_6}^*, \eta_{C_8}^*) = \frac{\gamma}{1 + \gamma \cdot \min(\beta_{C_6}^{**}, \beta_{C_8}^{**})}. \quad (5.14)$$

**Theorem 23** (Achievable Symmetric Rate Through Orthogonal Sharing Half-DoF Solutions). *An achievable symmetric rate, through orthogonal sharing schemes, of the wireless network, when Half-DoF solutions are considered, can be defined as the highest achievable symmetric rate among the achievable symmetric rates associated to all bi-directed interference topologies of the undominated orthogonal sharing Half-DoF unlabeled conflict graphs, as follows*

$$R_{\mathcal{W}}^*(\gamma) = \frac{1}{2} \cdot \log_2(1 + \eta^{**}) = \frac{1}{2} \cdot \log_2\left(1 + \frac{\gamma}{1 + \gamma \cdot \min(\beta_{C_6}^{**}, \beta_{C_8}^{**})}\right). \quad (5.15)$$

## 5.6 Half-DoF Through Interference Alignment

Let us define the IA *half-DoF* interference topologies as follows.

**Definition 43** (IA Half-DoF Interference Topologies). *An interference topology  $\mathcal{T}$  that can support in the TIM problem a symmetric DoF equal to 0.5 per message  $W_k \in \mathcal{W}$ , through IA scheme, is called an IA half-DoF interference topology.*

In [1], Jafar showed that 0.5 is the maximal symmetric DoF per message  $W_k \in \mathcal{W}$  except if the interference topology is fully disconnected. To achieve 0.5 DoF per message, an IA approach may be required. It is also known, from [1], that for any interference topology  $\mathcal{T}$ , if a 0.5 DoF per message  $W_k \in \mathcal{W}$  is achievable with orthogonal sharing then 0.5 DoF per message  $W_k \in \mathcal{W}$  is also achievable with IA.

**Theorem 24** (IA Half-DoF Interference Topologies). *An interference topology  $\mathcal{T}$  has a symmetric DoF equal to 0.5 per message  $W_k \in \mathcal{W}$ , through IA, if and only if there are no internal conflicts.*

To define internal conflicts, let us first define an alignment graph and an alignment set as follows:

**Definition 44** (Alignment Graph). *The alignment graph is an undirected graph, where each vertex represents a unique message from the set of all messages  $\mathcal{W}$  and an edge between the vertices that representing the messages  $W_i$  and  $W_j$ ,  $i \neq j$ , exists only if there exists a destination  $D_k$ ,  $k \neq i$  and  $k \neq j$ , which is simultaneously corrupted by sources  $S_i$  and  $S_j$ , i.e.,  $\{S_i \rightarrow D_k\} \in \mathcal{S}_k$  and  $\{S_j \rightarrow D_k\} \in \mathcal{S}_k$ .*

**Definition 45** (Alignment Set). *Each set of messages that correspond to vertices of a connected component of the alignment graph is called an alignment set.*

Internal conflict is now defined as follows:

**Definition 46** (Internal Conflict). *The existence of a conflict edge in the conflict graph between two vertices representing two messages belonging to the same alignment set is called an internal conflict.*

If an unlabeled conflict graph can correspond to any interference topology, such that, by considering the alignment graph and the conflict graph of this interference topology, we have no internal conflicts, then, this unlabeled conflict graph is called IA Half-DoF unlabeled conflict graph.

For the 4 users unicast TIM problem, we have, from the unlabeled conflict graphs shown in Fig. 5.4, 10 IA Half-DoF unlabeled conflict graphs,  $C_1, C_2, C_3, C_4, C_5, C_6, C_7, C_8, C_9, C_{10}$ . Among these 10 IA Half-DoF unlabeled conflict graphs,  $C_1, C_2, C_3, C_4, C_5, C_6, C_7, C_8, C_9, C_{10}$ , seven graphs,  $C_1, C_2, C_3, C_4, C_5, C_6, C_8$ , are also orthogonal sharing Half-DoF unlabeled conflict graphs, and since 0.5 is the maximal achievable symmetric DoF, then we can not have better performance for these graphs,  $C_1, C_2, C_3, C_4, C_5, C_6, C_8$ , using IA. Therefore, we consider only the three IA Half-DoF unlabeled conflict graphs,  $C_7, C_9, C_{10}$ , as shown in Fig. 5.9.

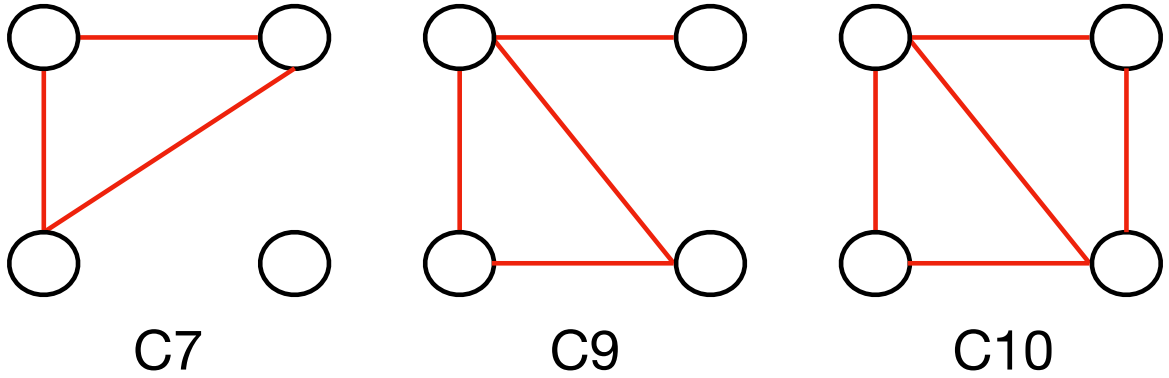

Figure 5.9: IA Half-DoF unlabeled conflict graphs.

Let us now define a directed-cyclic interference topology of an unlabeled conflict graph, as follows

**Definition 47** (4 Users Directed-Cyclic Interference Topology of An Unlabeled Conflict Graph). *A directed-cyclic interference topology of an unlabeled conflict graph is an unlabeled interference topology with 4 unlabeled vertices, i.e., 4 virtual labeled vertices  $w, x, y, z \in \{W_1, W_2, W_3, W_4\}$  and  $w \neq x \neq y \neq z$ , and it can be constructed by considering each closed loop in the unlabeled conflict graph as a directed cycle with no bidirected edges in the loop, and by considering each edge outside any closed loop in the unlabeled conflict graph as a bidirected edge.*

The directed-cyclic interference topologies of the IA Half-DoF unlabeled conflict graphs  $C_9$  and  $C_{10}$ , are shown in Fig. 5.10. The directed-cyclic interference topology of the IA Half-DoF unlabeled conflict graph  $C_7$  will not be considered in the following analysis since it is dominated by the directed-cyclic interference topologies of the IA Half-DoF unlabeled conflict graphs  $C_9$  and  $C_{10}$ .

An unlabeled conflict graph is called an IA Half-DoF unlabeled conflict graph if and only if it has a directed-cyclic interference topology, i.e., if and only if a directed-cyclic interference topology can be constructed through it. The unlabeled conflict graph  $C_{11}$  is not IA Half-DoF unlabeled conflict graph, since we can not, through it, construct a directed-cyclic interference topology.

**Theorem 25** (IA Half-DoF Interference Topologies). *An interference topology  $\mathcal{T}$  has a*

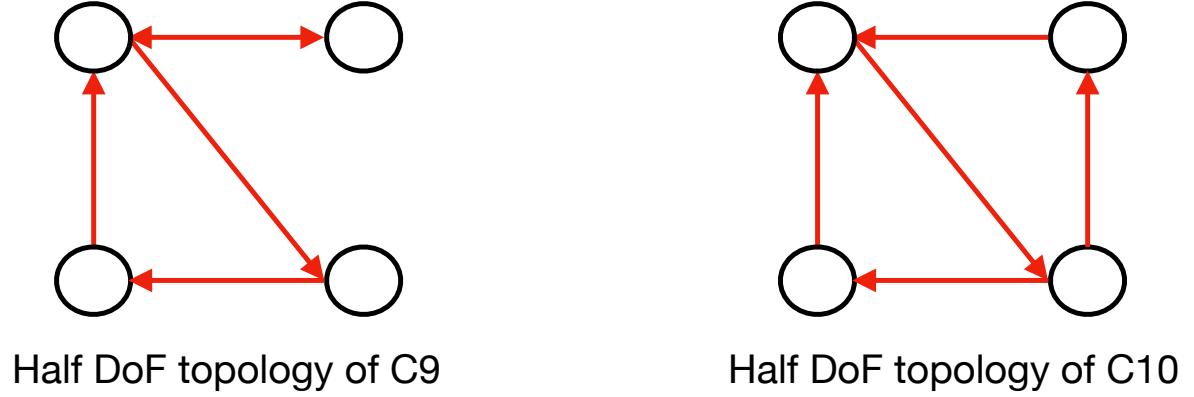

Figure 5.10: Directed-cyclic interference topologies of the IA Half-DoF unlabeled conflict graphs  $C_9$  and  $C_{10}$ .

*symmetric DoF equal to 0.5 per message  $W_k \in \mathcal{W}$ , through IA, if and only if it corresponds to a directed-cyclic interference topology of an unlabeled conflict graph.*

According to [1], IA allows to increase the DoF of the directed-cyclic interference topologies of the IA Half-DoF unlabeled conflict graphs  $C_9$  and  $C_{10}$ , to 0.5, by using non-orthogonal linear vectors, but in turns result in a degraded SINR due to the non-orthogonal IA penalty factor. This penalty comes from the fact that the receiver has to project the received signal in the interference-free subspace [3]. We can define this non-orthogonal IA penalty factor when Half-DoF solutions using IA are considered, as follows:

**Definition 48** (Non-Orthogonal IA Penalty Factor  $\alpha_{1/2}$  for Half-DoF Solutions). *The non-orthogonal IA penalty factor,  $\alpha_{1/2}$ , when Half-DoF solutions using IA are considered, is defined as follows*

$$\alpha_{1/2} = \sin^2 \left( \frac{\pi}{N_a} \right), \quad (5.16)$$

where  $N_a$  is the number of alignment sets when non-conflicting alignment sets are merged into one alignment set [1].

The number of alignment sets for the directed-cyclic interference topologies of the IA Half-DoF unlabeled conflict graphs  $C_9$  and  $C_{10}$ , is 4, and the number of alignment sets when non-conflicting alignment sets are merged into one alignment set, is  $N_a = 3$ . Then, the non-orthogonal IA penalty factor  $\alpha_{1/2}$  for the directed-cyclic interference topologies of  $C_9$  and  $C_{10}$ , is  $\alpha_{1/2} = \frac{\sqrt{3}}{2}$ .

Alignment sets when non-conflicting alignment sets are merged into one alignment set, for the directed-cyclic interference topologies of the IA Half-DoF unlabeled conflict graphs  $C_9$  and  $C_{10}$ , are shown in Fig. 5.11.

**Definition 49** (Achievable Symmetric Rate Through IA Half-DoF Solutions). *To characterize an achievable symmetric rate, through IA Half-DoF unlabeled conflict graphs, it is sufficient to evaluate the SINR of the directed-cyclic interference topologies of the IA Half-DoF unlabeled conflict graphs  $C_9$  and  $C_{10}$ .*

For the directed-cyclic interference topology of the IA Half-DoF unlabeled conflict graph  $C_9$ , the number of all automorphisms is  $aut = 1$ , then we have 24 distinct labelings of the

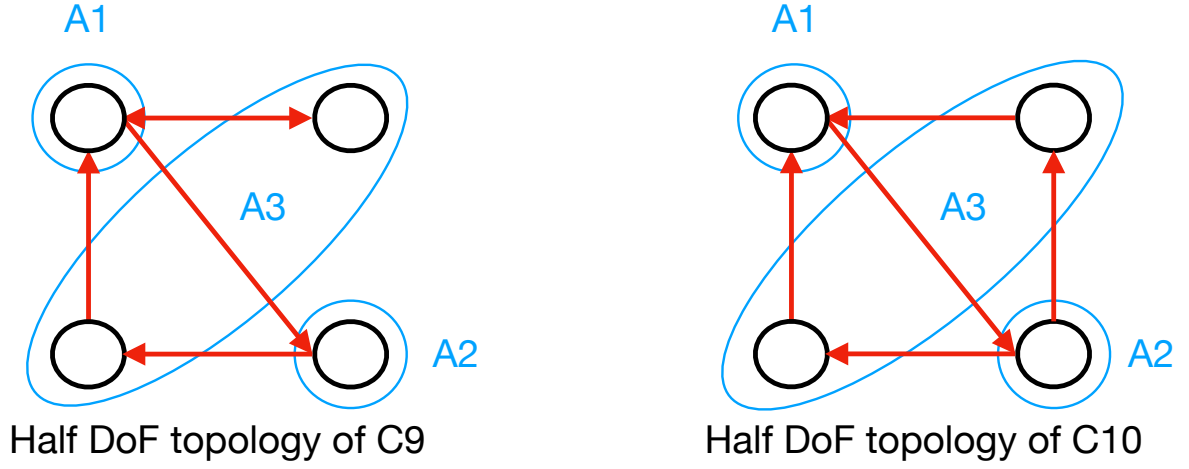

Figure 5.11: Alignment sets when non-conflicting alignment sets are merged into one alignment set, for the directed-cyclic interference topologies of  $C_9$  and  $C_{10}$ .

directed-cyclic interference topology of the IA Half-DoF unlabeled conflict graph  $C_9$ . While, for the directed-cyclic interference topology of the IA Half-DoF unlabeled conflict graph  $C_{10}$ , the number of all automorphisms is  $aut = 2$ , then we have 12 distinct labelings of the directed-cyclic interference topology of the IA Half-DoF unlabeled conflict graph  $C_{10}$ .

To evaluate the maximal SINR, through IA schemes, of the wireless network, when Half-DoF solutions are considered, we consider the complement graphs of the directed-cyclic interference topologies of the IA Half-DoF unlabeled conflict graphs  $C_9$  and  $C_{10}$ , as shown in Fig. 5.12.

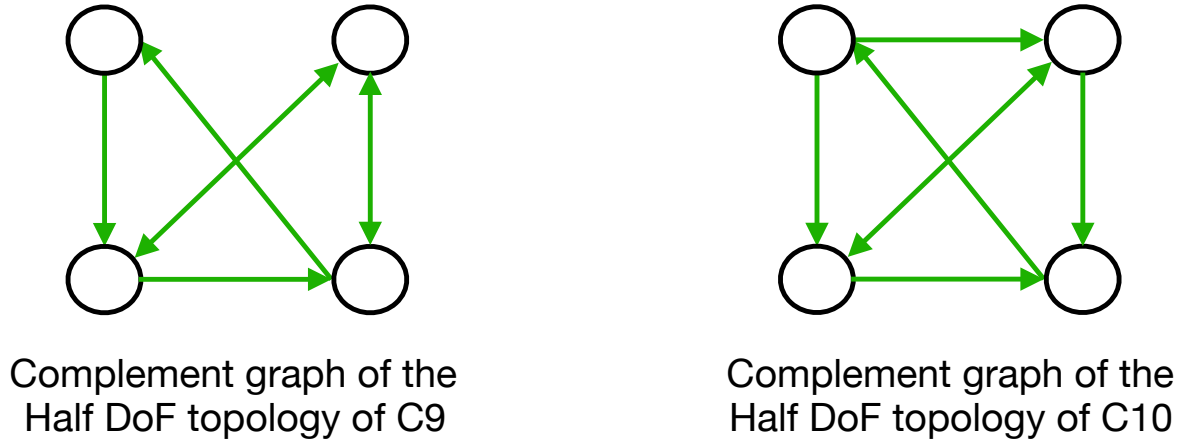

Figure 5.12: Complement graphs of the directed-cyclic interference topologies of the IA Half-DoF unlabeled conflict graphs  $C_9$  and  $C_{10}$ .

The maximal SINR that can be evaluated through the directed-cyclic interference topology of the IA Half-DoF unlabeled conflict graph  $C_9$ , is defined as

$$\eta_{C_9}^* = \frac{\alpha_{1/2}\gamma}{1 + \gamma\beta_{C_9}^{**}} = \frac{\frac{\sqrt{3}}{2}\gamma}{1 + \gamma\beta_{C_9}^{**}}, \quad (5.17)$$



where  $\beta_{C_9}^{**}$  is the minimal value among the 24  $\beta_{\mathcal{T}}^*$  values that correspond to the 24 distinct labelings of the directed-cyclic interference topology of  $C_9$ , and  $\beta_{C_9}^{**}$  can be evaluated through the complement graph of the directed-cyclic interference topology of the IA Half-DoF unlabeled conflict graph  $C_9$  shown in Fig. 5.12.

The maximal SINR that can be evaluated through the directed-cyclic interference topology of the IA Half-DoF unlabeled conflict graph  $C_{10}$ , is defined as

$$\eta_{C_{10}}^* = \frac{\alpha_{1/2}\gamma}{1 + \gamma\beta_{C_{10}}^{**}} = \frac{\frac{\sqrt{3}}{2}\gamma}{1 + \gamma\beta_{C_{10}}^{**}}, \quad (5.18)$$

where  $\beta_{C_{10}}^{**}$  is the minimal value among the 12  $\beta_{\mathcal{T}}^*$  values that correspond to the 12 distinct labelings of the directed-cyclic interference topology of  $C_{10}$ , and  $\beta_{C_{10}}^{**}$  can be evaluated through the complement graph of the directed-cyclic interference topology of the IA Half-DoF unlabeled conflict graph  $C_{10}$  shown in Fig. 5.12.

Then, the maximal SINR that can be evaluated, through IA schemes, of the wireless network, when Half-DoF solutions are considered, is defined as

$$\eta^{**} = \max(\eta_{C_9}^*, \eta_{C_{10}}^*) = \frac{\frac{\sqrt{3}}{2}\gamma}{1 + \gamma \cdot \min(\beta_{C_9}^{**}, \beta_{C_{10}}^{**})}. \quad (5.19)$$

**Theorem 26** (Achievable Symmetric Rate Through IA Half-DoF Solutions). *An achievable symmetric rate, through IA schemes, of the wireless network, when Half-DoF solutions are considered, can be defined as the highest achievable symmetric rate among the achievable symmetric rates associated to the directed-cyclic interference topologies of the IA Half-DoF unlabeled conflict graphs  $C_9$  and  $C_{10}$ , as follows*

$$R_W^*(\gamma) = \frac{1}{2} \cdot \log_2(1 + \eta^{**}) = \frac{1}{2} \cdot \log_2\left(1 + \frac{\frac{\sqrt{3}}{2}\gamma}{1 + \gamma \cdot \min(\beta_{C_9}^{**}, \beta_{C_{10}}^{**})}\right). \quad (5.20)$$

## 5.7 Half-DoF Topologies Versus Extreme Topologies

For the two extreme interference topologies of the 4 users wireless network: the fully connected interference topology and the fully disconnected interference topology, we define extreme interference topologies rate as follows:

**Definition 50** (Extreme Interference Topologies Rate). *We can define an achievable symmetric rate for the extreme interference topologies, denoted by  $R_E(\gamma)$ , as follows.*

$$R_E(\gamma) = \max\left(\frac{1}{4} \log_2(1 + \gamma), \log_2\left(1 + \frac{\gamma}{1 + \gamma\beta_m}\right)\right), \quad (5.21)$$

where  $\beta_m$ , defined in chapter 4 in property 2, with  $K = 4$ , is the lowest normalized interference threshold that leads to the construction of the fully disconnected interference topology of the 4 users wireless network.

In the following, we present a  $\beta^{**}$  outer bound that is able to specify if the optimal Half-DoF interference topology, i.e., the Half-DoF interference topology that has the highest achievable symmetric rate among the achievable symmetric rates associated to all Half-DoF interference

topologies, will outperform or not, at a given  $\gamma$ , the extreme interference topologies in terms of the achievable symmetric rate. We present this outer bound when orthogonal sharing is used and when IA is used, as follows.

**Theorem 27** ( $\beta_{6,8}^{**}$  Outer Bound: Orthogonal Sharing Half-DoF Solutions). *Given a wireless network with the bi-directed interference topologies of the undominated orthogonal sharing Half-DoF unlabeled conflict graphs  $C_6$  and  $C_8$ . Then, for a given  $\gamma$ , the optimal Half-DoF interference topology, when orthogonal sharing is used, outperforms the extreme interference topologies in terms of the achievable rate if and only if:*

$$\beta_{6,8}^{**} < \beta_{OS}^{**}(\gamma), \quad (5.22)$$

where  $\beta_{6,8}^{**} = \min(\beta_{C_6}^{**}, \beta_{C_8}^{**})$ , and  $\beta_{OS}^{**}(\gamma)$  is defined as

$$\beta_{OS}^{**}(\gamma) = \frac{1}{2^{2 \cdot R_E(\gamma)} - 1} - \frac{1}{\gamma}. \quad (5.23)$$

Fig. 5.13 shows the  $\beta_{6,8}^{**}$  outer bound versus SNR,  $\gamma$ , and for different  $\beta_m$  values. In Fig. 5.13, the optimal Half-DoF interference topology, when orthogonal sharing is used, outperforms, at a given  $\gamma$ , the extreme interference topologies in terms of the achievable symmetric rate if and only if the corresponding  $\beta^{**}$  value of the optimal Half-DoF interference topology, i.e.,  $\beta_{6,8}^{**}$ , is below the outer bound.

**Theorem 28** ( $\beta_{9,10}^{**}$  Outer Bound: IA Half-DoF Solutions). *Given a wireless network with the directed-cyclic interference topologies of the IA Half-DoF unlabeled conflict graphs  $C_9$  and  $C_{10}$ . Then, for a given  $\gamma$ , the optimal Half-DoF interference topology, when IA is used, outperforms the extreme interference topologies in terms of the achievable rate if and only if:*

$$\beta_{9,10}^{**} < \beta_{IA}^{**}(\gamma), \quad (5.24)$$

where  $\beta_{9,10}^{**} = \min(\beta_{C_9}^{**}, \beta_{C_{10}}^{**})$ , and  $\beta_{IA}^{**}(\gamma)$  is defined as

$$\beta_{IA}^{**}(\gamma) = \frac{\frac{\sqrt{3}}{2}}{2^{2 \cdot R_E(\gamma)} - 1} - \frac{1}{\gamma}. \quad (5.25)$$

Fig. 5.14 shows the  $\beta_{9,10}^{**}$  outer bound versus SNR,  $\gamma$ , and for different  $\beta_m$  values. In Fig. 5.14, the optimal Half-DoF interference topology, when IA is used, outperforms, at a given  $\gamma$ , the extreme interference topologies in terms of the achievable symmetric rate if and only if the corresponding  $\beta^{**}$  value of the optimal Half-DoF interference topology, i.e.,  $\beta_{9,10}^{**}$ , is below the outer bound.

## 5.8 Half-DoF Topologies: Orthogonal Sharing Versus IA

In the following, we present a  $\beta^{**}$  outer bound that is able to specify if the optimal IA Half-DoF interference topology, i.e., the IA Half-DoF interference topology that has the highest achievable symmetric rate among the achievable symmetric rates associated to all IA Half-DoF interference topologies, will outperform or not, at a given  $\gamma$ , the optimal orthogonal sharing Half-DoF interference topology, i.e., the orthogonal sharing Half-DoF interference topology that has the highest achievable symmetric rate among the achievable symmetric

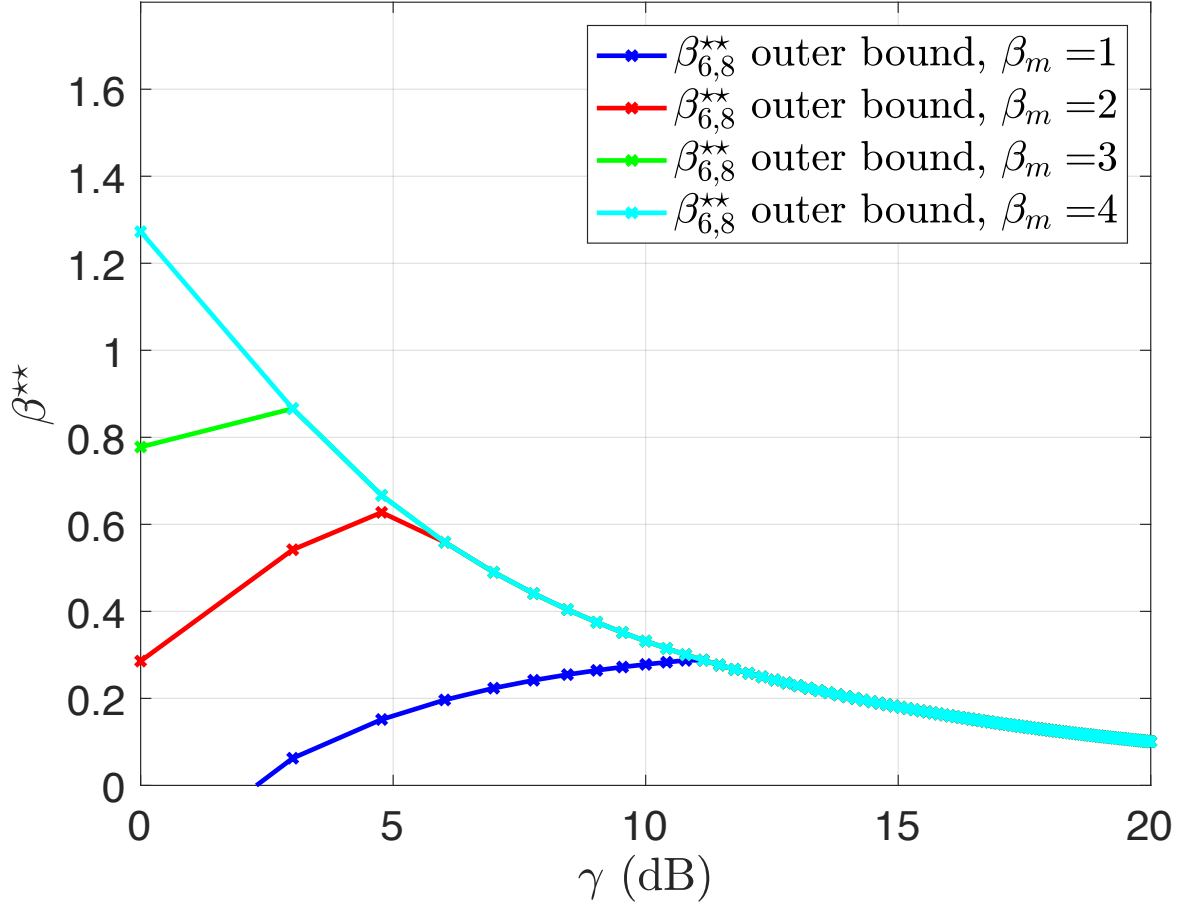

Figure 5.13:  $\beta_{6,8}^{**}$  outer bound versus SNR and for different  $\beta_m$  values.

rates associated to all orthogonal sharing Half-DoF interference topologies, in terms of the achievable symmetric rate.

**Theorem 29** ( $\beta_{9,10}^{**}$  Outer Bound: IA Half-DoF Outperforms Orthogonal Sharing Half-DoF). *Given a wireless network with the bi-directed interference topologies of the undominated orthogonal sharing Half-DoF unlabeled conflict graphs  $C_6$  and  $C_8$  and with the directed-cyclic interference topologies of the IA Half-DoF unlabeled conflict graphs  $C_9$  and  $C_{10}$ . Then, for a given  $\gamma$ , the optimal IA Half-DoF interference topology, when IA is used, outperforms the optimal orthogonal sharing Half-DoF interference topology, when orthogonal sharing is used, in terms of the achievable rate if and only if:*

$$\beta_{9,10}^{**} < \frac{\sqrt{3}}{2} \cdot \beta_{6,8}^{**} + \frac{\sqrt{3}-2}{2\gamma}, \quad (5.26)$$

where  $\beta_{9,10}^{**} = \min(\beta_{C_9}^{**}, \beta_{C_{10}}^{**})$ , and  $\beta_{6,8}^{**} = \min(\beta_{C_6}^{**}, \beta_{C_8}^{**})$ .

Fig. 5.15 shows the  $\beta_{9,10}^{**}$  outer bound versus SNR,  $\gamma$ , and for different  $\beta_{6,8}^{**}$  values. In Fig. 5.15, the optimal IA Half-DoF interference topology, when IA is used, outperforms, at a given  $\gamma$ , the optimal orthogonal sharing Half-DoF interference topology, when orthogonal

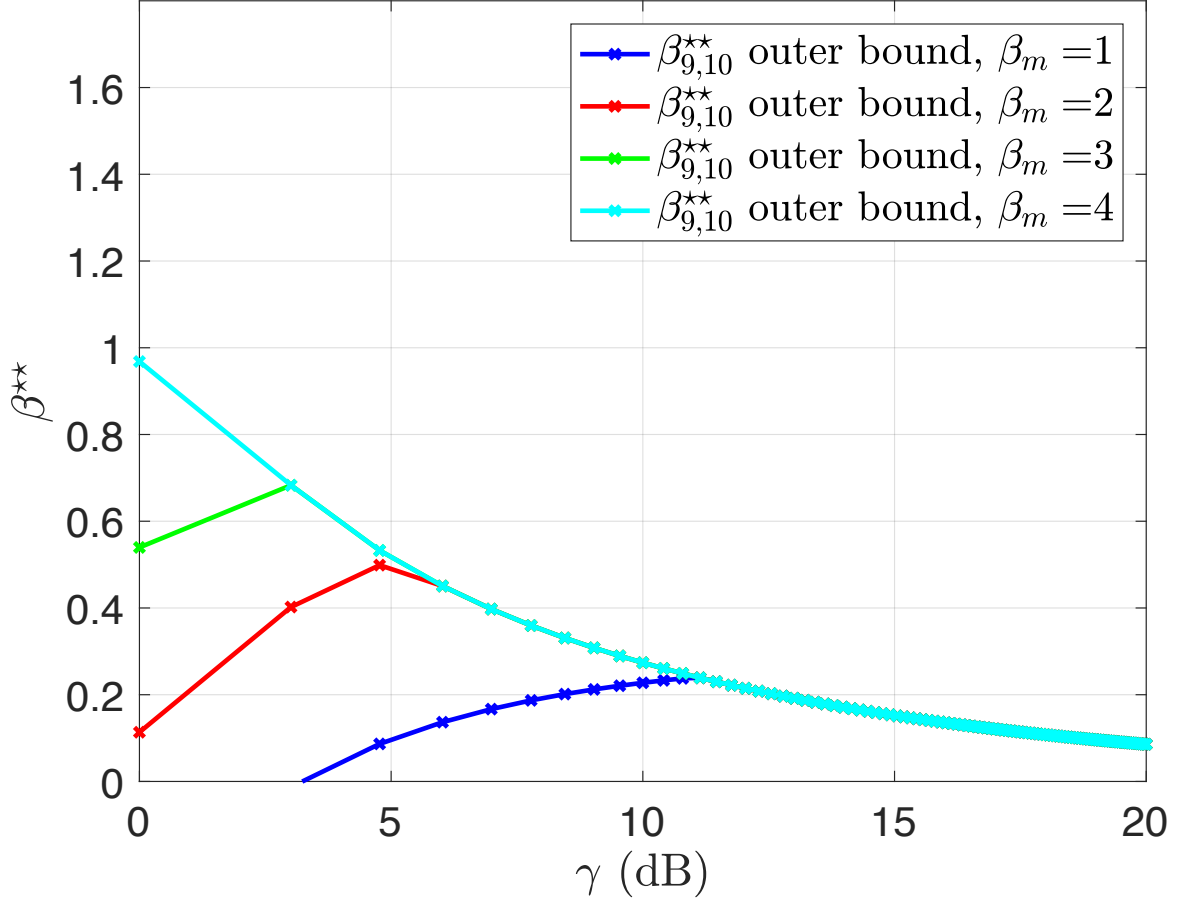

Figure 5.14:  $\beta_{9,10}^{**}$  outer bound versus SNR and for different  $\beta_m$  values.

sharing is used, in terms of the achievable symmetric rate if and only if the corresponding  $\beta^{**}$  value of the optimal IA Half-DoF interference topology, i.e.,  $\beta_{9,10}^{**}$ , is below the outer bound.

## 5.9 Conclusion

In this chapter, we have considered the TIM problem for four users wireless networks using the interference topology construction approach proposed in chapter 4. We have applied the achievable rates analysis, proposed in chapter 4, for all half-DoF interference topologies, through orthogonal sharing and through IA. We have compared the achievable symmetric rates of the half-DoF interference topologies, through orthogonal sharing and through IA, with the achievable symmetric rates of the extreme interference topologies. Finally, we have compared the performance of orthogonal sharing with the performance of IA, in terms of the achievable symmetric rates, for half-DoF interference topologies.

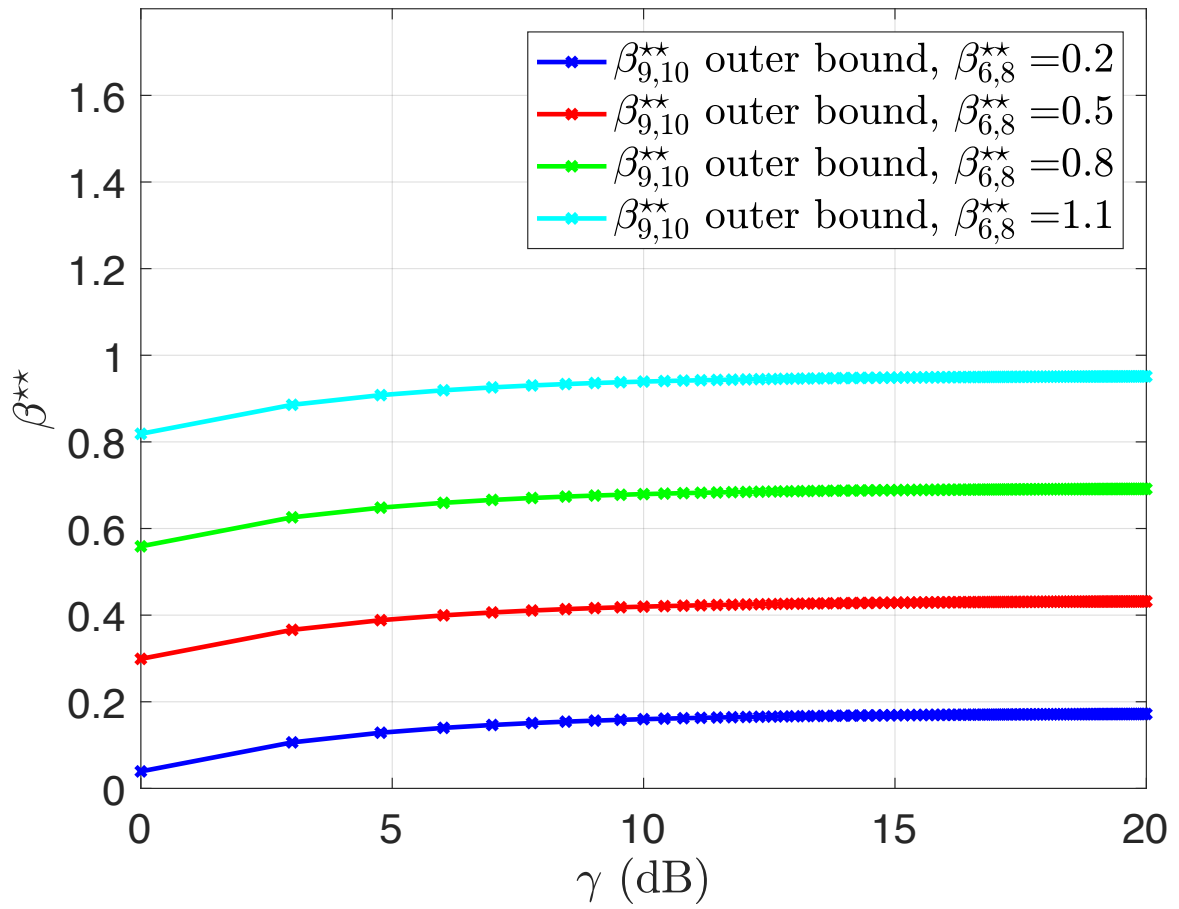

Figure 5.15: IA Half-DoF outperforms orthogonal sharing Half-DoF:  $\beta_{9,10}^{**}$  outer bound versus SNR and for different  $\beta_{6,8}^{**}$  values.

# 6

---

## Conclusion

This thesis has introduced two main problems. First, the TIM problem for downlink cellular networks has been considered in chapter 3. In the first part of this chapter, we have presented the TIM problem for infinite downlink cellular networks, when the mobile users are considered to be located at the boundaries between the adjacent cells where the interference is the most severe, and with multi-layer interference topology, i.e., with an interference topology such that the significant interference in the TIM problem can be considered from base stations in cells beyond the immediately adjacent cells. In this TIM problem with the multi-layer interference topology, we have presented the achievable DoF solution using the conventional frequency reuse scheme and the optimal DoF solution that can be achieved using an aligned frequency reuse scheme. This has shown that the DoF gain through the optimal TIM scheme over the conventional frequency reuse scheme diminishes when the interference topology becomes connected with more significant interference links. In the second part of this chapter, we have presented the TIM problem for the infinite 1D (linear) and the infinite 2D (hexagonal) downlink cellular networks when a continuous uniform distribution of mobile users is adopted. In the both TIM problems, for the infinite 1D (linear) and the infinite 2D (hexagonal) downlink cellular networks, the TIM network topology then has been built upon the interference distance threshold, and the optimal DoF solution has been computed accordingly. A fractional coloring scheme achieving this DoF solution has been also proposed. We have shown the trade-off between DoF and SIR in the network performance relying on the interference threshold parameter. This has shown that the efficiency of a TIM approach is strongly impacted by an appropriate selection of the interference threshold parameter. Second, a new approach to convert a multi-user wireless network into a TIM model using a normalized interference threshold  $\beta$  that ensures the validity of the interference topology for all SNRs has been introduced in chapter 4. Based on this approach, we are able to evaluate the achievable rate's theoretical limit, in the asymptotic SNR regime, for the underlying wireless network and not just for its topological interference representation. This approach allows us to cope with the finite SNR regime and not just with the asymptotic SNR regime with the DoF analysis. Based on this approach, the TIM analysis exhibits the fundamental trade-off between DoF and SINR maximization. This contribution is complementary to classical work related to TIM since the focus is clearly on the formulation of a TIM problem. This approach provides a better evaluation of the achievable symmetric rate of the initial wireless network. Also in

chapter 4, we have presented outer bound solutions on the normalized interference threshold parameter for interference topologies with half-DoF-feasibility, considering both an orthogonal resource allocation and IA. These bounds specify if a given half-DoF-feasible interference topology can be, in terms of the achievable rate, the best topology or not. Using this result, we limit the search space in the normalized interference threshold parameter range, to find half-DoF-feasible interference topologies having the possibility to be the best topologies in terms of the achievable rate. Finally, the TIM problem for four users wireless networks, using the interference topology construction approach proposed in chapter 4, has been considered in chapter 5. In this chapter, we have applied the achievable rates analysis for all interference topologies with half-DoF-feasibility, through orthogonal sharing and through IA, in the TIM problem of four users wireless network. Then, we have compared the achievable symmetric rates of the half-DoF interference topologies, through orthogonal sharing and through IA, with the achievable symmetric rates of the extreme interference topologies. Finally in chapter 5, we have compared the performance of orthogonal sharing with the performance of IA, in terms of the achievable symmetric rates, for half-DoF interference topologies.

---

# Bibliography

- [1] S. A. Jafar, “Topological interference management through index coding,” *IEEE Transactions on Information Theory*, vol. 60, no. 1, pp. 529–568, 2014.
- [2] T. S. Rappaport, *Wireless communications: principles and practice*. prentice hall PTR New Jersey, 1996, vol. 2.
- [3] V. R. Cadambe and S. A. Jafar, “Interference alignment and degrees of freedom of the k-user interference channel,” *IEEE TRANSACTIONS ON INFORMATION THEORY*, vol. 54, no. 8, p. 3425, 2008.
- [4] H. Zhang, S. Chen, X. Li, H. Ji, and X. Du, “Interference management for heterogeneous networks with spectral efficiency improvement,” *IEEE Wireless Communications*, vol. 22, no. 2, pp. 101–107, 2015.
- [5] V. R. Cadambe and S. A. Jafar, “Interference Alignment and Degrees of Freedom of the K-User Interference Channel,” *IEEE Transactions on Information Theory*, vol. 54, no. 8, pp. 3425–3441, aug 2008. [Online]. Available: <http://ieeexplore.ieee.org/document/4567443/>
- [6] C. Suh and D. Tse, “Interference alignment for cellular networks,” in *Communication, Control, and Computing, 2008 46th Annual Allerton Conference on*. IEEE, 2008, pp. 1037–1044.
- [7] X. Chen, Z. Zhang, L. Zheng, L. Wu, J. Dang, P.-S. Lu, and C. Sun, “Blind interference alignment in two-cell z interference mimo channel,” *IEEE Access*, vol. 5, pp. 10 526–10 532, 2017.
- [8] S. A. Jafar, “Blind interference alignment,” *IEEE Journal of Selected Topics in Signal Processing*, vol. 6, no. 3, pp. 216–227, 2012.
- [9] Y. Birk and T. Kol, “Informed-source coding-on-demand (iscod) over broadcast channels,” in *Proceedings IEEE INFOCOM*. IEEE, pp. 1257–1264.
- [10] —, “Coding on demand by an informed source (iscod) for efficient broadcast of different supplemental data to caching clients,” *IEEE Transactions on Information Theory*, vol. 52, no. 6, pp. 2825–2830, 2006.



- [11] H. Maleki, V. R. Cadambe, and S. A. Jafar, “Index coding—an interference alignment perspective,” *IEEE Transactions on Information Theory*, vol. 60, no. 9, pp. 5402–5432, 2014.
- [12] H. Maleki and S. A. Jafar, “Optimality of orthogonal access for one-dimensional convex cellular networks,” *IEEE communications letters*, vol. 17, no. 9, pp. 1770–1773, 2013.
- [13] X. Yi, H. Sun, S. A. Jafar, and D. Gesbert, “Tdma is optimal for all-unicast dof region of tim if and only if topology is chordal bipartite,” *IEEE Transactions on Information Theory*, vol. 64, no. 3, pp. 2065–2076, 2018.
- [14] F. Arbabjolfaei, B. Bandemer, Y.-H. Kim, E. Şaşoğlu, and L. Wang, “On the capacity region for index coding,” in *Information Theory Proceedings (ISIT), 2013 IEEE International Symposium on*. IEEE, 2013, pp. 962–966.
- [15] N. Naderializadeh and A. S. Avestimehr, “Interference networks with no csit: Impact of topology,” *IEEE Transactions on Information Theory*, vol. 61, no. 2, pp. 917–938, 2014.
- [16] Y. Gao, G. Wang, and S. A. Jafar, “Topological interference management for hexagonal cellular networks,” *IEEE Transactions on Wireless Communications*, vol. 14, no. 5, pp. 2368–2376, 2015.
- [17] B. Hassibi, “Topological interference alignment in wireless networks.”
- [18] H. Sun and S. A. Jafar, “Topological interference management with multiple antennas,” in *2014 IEEE International Symposium on Information Theory*. IEEE, 2014, pp. 1767–1771.
- [19] Y. Gao, G. Wang, and S. A. Jafar, “Topological interference management for hexagonal cellular networks,” *IEEE Transactions on Wireless Communications*, vol. 14, no. 5, pp. 2368–2376, 2014.
- [20] H. Yang, N. Naderializadeh, A. S. Avestimehr, and J. Lee, “Topological interference management with reconfigurable antennas,” *IEEE Transactions on Communications*, vol. 65, no. 11, pp. 4926–4939, 2017.
- [21] X. Yi and D. Gesbert, “Topological interference management with transmitter cooperation,” *IEEE Transactions on Information Theory*, vol. 61, no. 11, pp. 6107–6130, 2015.
- [22] X. Yi and G. Caire, “Topological interference management with decoded message passing,” *IEEE Transactions on Information Theory*, vol. 64, no. 5, pp. 3842–3864, 2018.
- [23] W. Liu, Y. Han, J. Li, and Y. Ma, “Topological interference management with transmitter cooperation for mimo interference channels,” *IEEE Transactions on Vehicular Technology*, vol. 67, no. 11, pp. 10 564–10 573, 2018.
- [24] N. Naderializadeh, A. El Gamal, and A. S. Avestimehr, “Topological interference management with just retransmission: What are the “best” topologies?” in *2015 IEEE International Conference on Communications (ICC)*. IEEE, 2015, pp. 4113–4119.

- 
- [25] W. Liu, D. Chen, J. Li, and Y. Ma, "Topological interference management for mimo interference broadcast channels," *IEEE Access*, vol. 7, pp. 38 055–38 067, 2019.
- [26] H. Kallam, L. S. Cardoso, and J. M. Gorce, "Topological interference management: Trade-off between dof and sir for cellular systems," in *2019 26th International Conference on Telecommunications (ICT)*. IEEE, 2019, pp. 96–101.
- [27] W. Liu, S. Xue, J. Li, and L. Hanzo, "Topological interference management for wireless networks," *IEEE Access*, vol. 6, pp. 76 942–76 955, 2018.
- [28] E. R. Scheinerman and D. H. Ulman, *Fractional Graph Theory: A Rational Approach to the Theory of Graphs*. New York: John Wiley and Sons, Inc., 1997.
- [29] O. El Ayach, A. Lozano, and R. W. Heath, "On the overhead of interference alignment: Training, feedback, and cooperation," *IEEE Transactions on Wireless Communications*, vol. 11, no. 11, pp. 4192–4203, 2012.
- [30] M. A. Maddah-Ali and D. Tse, "Completely stale transmitter channel state information is still very useful," *IEEE Transactions on Information Theory*, vol. 58, no. 7, pp. 4418–4431, 2012.
- [31] R. Tandon, S. A. Jafar, S. Shamai, and H. V. Poor, "On the synergistic benefits of alternating csit for the miso broadcast channel," *IEEE Transactions on Information Theory*, vol. 59, no. 7, pp. 4106–4128, 2013.
- [32] N. Naderializadeh and A. S. Avestimehr, "Interference networks with no csit: Impact of topology."
- [33] A. El Gamal, N. Naderializadeh, and A. S. Avestimehr, "When does an ensemble of matrices with randomly scaled rows lose rank?" *dim (SJ Bi., Yi)*, vol. 1, p. 1.
- [34] Z. Bar-Yossef, Y. Birk, T. S. Jayram, and T. Kol, "Index coding with side information," *IEEE Trans. on Information Theory*, vol. 57, pp. 1479–1494, March 2011.
- [35] X. Yi, H. Sun, S. A. Jafar, and D. Gesbert, "Tdma is optimal for all-unicast dof region of tim if and only if topology is chordal bipartite," *IEEE Transactions on Information Theory*, vol. 64, pp. 2065–2076, 2018.
- [36] H. Sun and S. A. Jafar, "Index coding capacity: How far can one go with only shannon inequalities?" *IEEE Transactions on Information Theory*, vol. 61, no. 6, pp. 3041–3055, 2015.
- [37] E. J. Candès and B. Recht, "Exact matrix completion via convex optimization," *Foundations of Computational mathematics*, vol. 9, no. 6, p. 717, 2009.
- [38] H. Esfahanizadeh, F. Lahouti, and B. Hassibi, "A matrix completion approach to linear index coding problem," in *Information Theory Workshop (ITW), 2014 IEEE*. IEEE, 2014, pp. 531–535.
- [39] Y. Shi, J. Zhang, and K. B. Letaief, "Low-rank matrix completion via riemannian pursuit for topological interference management," in *Information Theory (ISIT), 2015 IEEE International Symposium on*. IEEE, 2015, pp. 1831–1835.

- [40] —, “Low-rank matrix completion for topological interference management by riemannian pursuit,” *arXiv preprint arXiv:1603.01729*, 2016.
- [41] Y. Shi, B. Mishra, and W. Chen, “Topological interference management with user admission control via riemannian optimization,” *IEEE Transactions on Wireless Communications*, vol. 16, no. 11, pp. 7362–7375, 2017.
- [42] F. Zhang, Q. Wu, H. Wang, and Y. Shi, “Topological interference alignment via generalized low-rank optimization with sequential convex approximations,” *2018 IEEE 19th International Workshop on Signal Processing Advances in Wireless Communications (SPAWC)*, pp. 1–5, 2018.
- [43] H. Maleki and S. Jafar, “Optimality of orthogonal access for onedimensional convex cellular networks,” *IEEE Commun. Lett.*, vol. 17, pp. 1770–1773, Sep. 2013.
- [44] P. Mogensen, W. Na, I. Z. Kovács, F. Frederiksen, A. Pokhariyal, K. I. Pedersen, T. Kolding, K. Hugl, and M. Kuusela, “Lte capacity compared to the shannon bound,” in *Vehicular Technology Conference, 2007. VTC2007-Spring. IEEE 65th.* IEEE, 2007, pp. 1234–1238.
- [45] M. C. Necker, “Coordinated fractional frequency reuse,” in *Proceedings of the 10th ACM Symposium on Modeling, analysis, and simulation of wireless and mobile systems.* ACM, 2007, pp. 296–305.
- [46] M. Assaad, “Optimal fractional frequency reuse (ffr) in multicellular ofdma system,” in *Vehicular Technology Conference, 2008. VTC 2008-Fall. IEEE 68th.* IEEE, 2008, pp. 1–5.
- [47] L. Bai, T. Liu, Z. Chen, and C. Yang, “A graph-based interference topology control for ultra-dense networks,” in *Signal Processing (ICSP), 2014 12th International Conference on.* IEEE, 2014, pp. 1676–1681.
- [48] M. Fewell, “Area of common overlap of three circles,” DEFENCE SCIENCE AND TECHNOLOGY ORGANISATION EDINBURGH (AUSTRALIA) MARITIME . . . , Tech. Rep., 2006.
- [49] M. Guillaud and D. Gesbert, “Interference alignment in the partially connected k-user mimo interference channel,” in *Signal Processing Conference, 2011 19th European.* IEEE, 2011, pp. 1095–1099.
- [50] S. A. Jafar *et al.*, “Interference alignment—a new look at signal dimensions in a communication network,” *Foundations and Trends® in Communications and Information Theory*, vol. 7, no. 1, pp. 1–134, 2011.
- [51] G. C. Alexandropoulos, P. Ferrand, J.-M. Gorce, and C. B. Papadias, “Advanced coordinated beamforming for the downlink of future lte cellular networks,” *IEEE Communications Magazine*, vol. 54, no. 7, pp. 54–60, 2016.
- [52] T. Gou, C. Wang, and S. A. Jafar, “Aiming perfectly in the dark-blind interference alignment through staggered antenna switching,” *IEEE Transactions on Signal Processing*, vol. 59, no. 6, pp. 2734–2744, 2011.

- 
- [53] J. Hoadley and P. Maveddat, “Enabling small cell deployment with hetnet,” *IEEE Wireless Communications*, vol. 19, no. 2, pp. 4–5, April 2012.
- [54] A. Carleial, “Interference channels,” *IEEE Transactions on Information Theory*, vol. 24, no. 1, pp. 60–70, January 1978.
- [55] S. Jafar, “Topological interference management through index coding,” *IEEE Trans. Inf. Theory*, vol. 60, pp. 529–568, Jan. 2014.
- [56] A. Tehrani, A. Dimakis, and M. Neely, “Bipartite index coding,” *Proceedings of International Symposium on Information Theory (ISIT)*, 2012.
- [57] M. Egan, J. M. Gorce, and L. S. Cardoso, “Internal report fed4pmr - spectrum sensing for pmr,” 2017.
- [58] A. Blasiak, R. Kleinberg, and E. Lubetzky, “Index coding via linear programming,” *ArXiv:1004.1379*, April 2010.
- [59] H. Maleki, V. Cadambe, and S. Jafar, “Index coding —an interference alignment perspective,” *ISIT 2012*, 2012.
- [60] M. J. Neely, A. S. Tehrani, and Z. Zhang, “Dynamic index coding for wireless broadcast networks,” *INFOCOM*, 2012.
- [61] V. Cadambe and S. Jafar, “Interference alignment and the degrees of freedom of the k user interference channel,” *IEEE Trans. Inf. Theory*, vol. 54, pp. 3425–3441, Aug. 2008.
- [62] B. Nazer, M. Gastpar, S. Jafar, and S. Vishwanath, “Ergodic interference alignment,” *IEEE Trans. Inf. Theory*, vol. 58, pp. 6355–6371, Oct. 2012.
- [63] R. Ash, *Information Theory*. New York, USA: Dover publications, Inc, 1990.
- [64] R. Gallager, *Information Theory and Reliable Communication*. New York, USA: John Wiley and Sons, Inc, 1968.
- [65] W. Saad, Z. Han, and H. Poor, “Coalitional game theory for cooperative micro-grid distribution networks,” in *IEEE International Conference on Communications (ICC)*, Budapest, Hungary, Jun. 2011.
- [66] S. M. Perlaza and S. Lasaulce, *Game-Theoretic Solution Concepts and Learning Algorithms*. New York, NY, USA: Cambridge University Press, 2013.
- [67] F. Sun and H. C. A. Van Tilborg, “Approaching capacity by equiprobable signaling on the gaussian channel,” *IEEE Transactions on Information Theory*, vol. 39, pp. 1714–1716, Sep. 1993.
- [68] G. Ungerboeck, “Channel coding with multilevel/phase signals,” *IEEE Transactions on Information Theory*, vol. IT-28, No 1, pp. 55–67, Jan. 1982.
- [69] I. S. Gradshteyn and I. M. Ryzhik, *Table of Integrals, Series and Products*. Oxford, UK: Academic Press, 2007.

- [70] A. El Gamal and T. Cover, “Multiple user information theory,” *Proceedings of the IEEE*, vol. 68, pp. 1466–1483, Dec. 1980.
- [71] R. Ahlswede, “Multi-way communication channels,” *Proceedings Second International Symposium on Information Theory*, pp. 23–52, 1971.
- [72] N. T. Gaarder and J. K. Wolf, “The capacity region of a multiple-access discrete memoryless channel can increase with feedback,” *IEEE Transactions on Information Theory*, vol. 21, no. 1, pp. 100–102, Jan. 1975.
- [73] N. Jindal, S. Vishwanath, and A. Goldsmith, “On the duality of gaussian multiple-access and broadcast channels,” *IEEE Transactions on Information Theory*, vol. 50, no. 5, pp. 768–783, May. 2004.
- [74] R. H. Etkin, D. N. C. Tse, and H. Wang, “Gaussian interference channel capacity to within one bit,” *IEEE Transactions on Information Theory*, vol. 54, no. 12, pp. 5534–5562, Dic. 2008.
- [75] T. M. Cover, “Broadcast channels,” *IEEE Transactions on Information Theory*, vol. IT-18, no. 1, pp. 2–14, Jan. 1972.
- [76] T. S. Han and K. Kobayashi, “A new achievable rate region for the interference channel,” *IEEE Transactions on Information Theory*, vol. 27, pp. 49–60, Jan. 1981.
- [77] S. Avestimehr, S. Diggavi, and D. N. C. Tse, “Wireless network information flow: A deterministic approach,” *IEEE Transactions on Information Theory*, vol. 57, no. 4, pp. 1872–1905, Apr. 2011.
- [78] C. Suh and D. N. C. Tse, “Feedback capacity of the Gaussian interference channel to within 2 bits,” *IEEE Transactions on Information Theory*, vol. 57, no. 5, pp. 2667–2685, May 2011.
- [79] S. M. Perlaza, R. Tandon, H. V. Poor, and Z. Han, “Perfect output feedback in the two-user decentralized interference channel,” *IEEE Transactions on Information Theory*, vol. 61, no. 10, pp. 5441–5462, Oct. 2015.
- [80] R. Berry and D. Tse, “Shannon meets Nash on the interference channel,” *IEEE Transactions on Information Theory*, vol. 57, no. 5, pp. 2821 – 2836, May 2011.
- [81] G. Bresler and D. Tse, “The two user Gaussian interference channel: a deterministic view,” *European Transactions on Telecommunications*, vol. 19, no. 4, pp. 333 – 354, Apr 2008.
- [82] S.-Q. Le, R. Tandon, M. Motani, and H. V. Poor, “Approximate capacity region for the symmetric Gaussian interference channel with noisy feedback,” *IEEE Transactions on Information Theory*, vol. 61, no. 7, pp. 3737 – 3762, Jul. 2015.
- [83] D. Tuninetti, “On interference channel with generalized feedback (IFC-GF),” in *Proc. of International Symposium on Information Theory (ISIT)*, Nice, France, Jun. 2007, pp. 2661–2665.

- 
- [84] T. M. Cover and C. S. K. Leung, "An achievable rate region for the multiple-access channel with feedback," *IEEE Transactions on Information Theory*, vol. 27, no. 3, pp. 292–298, May 1981.
- [85] J. A. Thomas, "Feedback can at most double Gaussian multiple access channel capacity," *IEEE Transactions on Information Theory*, vol. 33, no. 5, pp. 711–716, Sep. 1987.
- [86] L. H. Ozarow, "The capacity of the white Gaussian multiple access channel with feedback," *IEEE Transactions on Information Theory*, vol. 30, no. 4, pp. 623–629, Jul. 1984.
- [87] C. Leung, *Multi-user and wiretap channels including feedback*. Stanford, USA: PhD Thesis, Stanford University, 1978.
- [88] F. Willems, "The discrete memoryless multiple access channel with partially cooperating encoders (corresp.)," *Information Theory, IEEE Transactions on*, vol. 29, no. 3, pp. 441–445, 1983.
- [89] S. Yang and D. Tuninetti, "Interference channel with generalized feedback (a.k.a. with source cooperation): Part I: Achievable region," *IEEE Transactions on Information Theory*, vol. 5, no. 57, p. 25, May. 2011.
- [90] P. Elias, A. Feinstein, and C. E. Shannon, "A note on the maximum flow through a network," *IRE Transactions on Information Theory*, vol. 2, no. 4, pp. 117–119, Dec. 1956.
- [91] A. Sahai, V. Aggarwal, M. Yuksel, and A. Sabharwal, "Capacity of all nine models of channel output feedback for the two-user interference channel," *arXiv:1104.4805*, 2013.
- [92] V. M. Pabhakaran and P. Viswanath, "Interference channel with source cooperation," *IEEE Transactions on Information Theory*, vol. 57, no. 1, pp. 156–186, Jan, 2011. 2011.
- [93] G. Bresler and D. N. C. Tse, "The two user Gaussian interference channel: A deterministic view," *European Transactions on Telecommunications*, vol. 19, no. 4, pp. 333–354, Apr. 2008.
- [94] S. P. Boyd and L. Vandenberghe, *Convex Optimization*. New York, NY: Cambridge University Press, 2004.
- [95] V. Quintero, S. M. Perlaza, and J.-M. Gorce, "Noisy channel-output feedback capacity of the linear deterministic interference channel," INRIA Grenoble - Rhône-Alpes, Tech. Rep. 456, Jan. 2015.
- [96] —, "Noisy channel-output feedback capacity of the linear deterministic interference channel," in *Proc. of the IEEE Information Theory Workshop (ITW)*, Jeju Island, Korea, Oct. 2015.
- [97] S. M. Perlaza, R. Tandon, and H. V. Poor, "Symmetric decentralized interference channels with noisy feedback," in *Proc. IEEE Intl. Symposium on Information Theory (ISIT)*, Honolulu, HI, USA, Jun. 2014.
- [98] S. M. Perlaza, R. Tandon, H. V. Poor, and Z. Han, "The Nash equilibrium region of the linear deterministic interference channel with feedback," in *Proc. 50th Annual Allerton Conference on Communications, Control, and Computing*, Monticello, IL, Oct. 2012.

- [99] S. A. Jafar, “Topological interference management through index coding,” *IEEE Transactions on Information Theory*, vol. 60, no. 1, pp. 529–568, 2014.
- [100] S. Y. E. Rouayheb, A. Sprintson, and C. N. Georghiades, “On the index coding problem and its relation to network coding and matroid theory,” *arXiv preprint arXiv:0810.0068*, 2008.
- [101] M. Effros, S. El Rouayheb, and M. Langberg, “An equivalence between network coding and index coding,” *IEEE Transactions on Information Theory*, vol. 61, no. 5, pp. 2478–2487, 2015.
- [102] Z. Bar-Yossef, Y. Birk, T. Jayram, and T. Kol, “Index coding with side information,” *IEEE Transactions on Information Theory*, vol. 57, no. 3, pp. 1479–1494, 2011.
- [103] A. Blasiak, R. Kleinberg, and E. Lubetzky, “Broadcasting with side information: Bounding and approximating the broadcast rate,” *IEEE Transactions on Information Theory*, vol. 59, no. 9, pp. 5811–5823, 2013.
- [104] A. S. Tehrani, A. G. Dimakis, and M. J. Neely, “Bipartite index coding,” in *Information Theory Proceedings (ISIT), 2012 IEEE International Symposium on*. IEEE, 2012, pp. 2246–2250.
- [105] K. Shanmugam, A. G. Dimakis, and M. Langberg, “Local graph coloring and index coding,” in *Information Theory Proceedings (ISIT), 2013 IEEE International Symposium on*. IEEE, 2013, pp. 1152–1156.
- [106] L. Ong, “Linear codes are optimal for index-coding instances with five or fewer receivers,” in *Information Theory (ISIT), 2014 IEEE International Symposium on*. IEEE, 2014, pp. 491–495.
- [107] M. B. Vaddi and B. S. Rajan, “On the capacity of index coding problems with symmetric neighboring interference,” in *Information Theory Workshop (ITW), 2017 IEEE*. IEEE, 2017, pp. 294–298.
- [108] M. Kim, Y. Chen, and S. Vishwanath, “Approximate capacity of a class of partially connected interference channels,” in *Information Theory (ISIT), 2017 IEEE International Symposium on*. IEEE, 2017, pp. 654–658.
- [109] P. Krishnan and V. Lalitha, “A class of index coding problems with rate  $1/3$ ,” in *Information Theory (ISIT), 2016 IEEE International Symposium on*. IEEE, 2016, pp. 130–134.
- [110] V. Lalitha and P. Krishnan, “Rate  $1/3$  index coding: Forbidden and feasible configurations,” in *Information Theory (ISIT), 2017 IEEE International Symposium on*. IEEE, 2017, pp. 3070–3074.
- [111] A. Thomas and B. S. Rajan, “Index coding with restricted information (icri) and interference alignment,” in *GLOBECOM 2017-2017 IEEE Global Communications Conference*. IEEE, 2017, pp. 1–7.

- 
- [112] Y. Shi, J. Zhang, W. Chen, and K. B. Letaief, “Generalized sparse and low-rank optimization for ultra-dense networks,” *IEEE Communications Magazine*, vol. 56, no. 6, pp. 42–48, 2018.
- [113] N. Jindal, S. Vishwanath, and A. Goldsmith, “On the duality of gaussian multiple-access and broadcast channels,” in *Information Theory, 2002. Proceedings. 2002 IEEE International Symposium on*. IEEE, 2002, p. 500.
- [114] S. Vishwanath, N. Jindal, and A. Goldsmith, “Duality, achievable rates, and sum-rate capacity of gaussian mimo broadcast channels,” *IEEE Transactions on Information Theory*, vol. 49, no. 10, pp. 2658–2668, 2003.
- [115] P. Viswanath and D. N. C. Tse, “Sum capacity of the vector gaussian broadcast channel and uplink-downlink duality,” *IEEE Transactions on Information Theory*, vol. 49, no. 8, pp. 1912–1921, 2003.
- [116] X. Yi, H. Sun, S. A. Jafar, and D. Gesbert, “Fractional Coloring (Orthogonal Access) achieves All-unicast Capacity (DoF) Region of Index Coding (TIM) if and only if Network Topology is Chordal,” *arXiv:1501.07870 [cs, math]*, no. i, 2015. [Online]. Available: <http://arxiv.org/abs/1501.07870> <http://www.arxiv.org/pdf/1501.07870.pdf>
- [117] A. G. Davoodi and S. A. Jafar, “Network Coherence Time Matters – Aligned Image Sets and the Degrees of Freedom of Interference Networks with Finite Precision CSIT and Perfect CSIR,” vol. 2, 2017.
- [118] S. El Rouayheb, A. Sprintson, and C. Georghiades, “On the Index Coding Problem and Its Relation to Network Coding and Matroid Theory,” *IEEE Transactions on Information Theory*, vol. 56, no. 7, pp. 3187–3195, 7 2010. [Online]. Available: <http://ieeexplore.ieee.org/articleDetails.jsp?arnumber=5484982>
- [119] Y. Gao, G. Wang, and S. A. Jafar, “Topological interference management for hexagonal cellular networks,” *IEEE Transactions on Wireless Communications*, vol. 14, no. 5, pp. 2368–2376, 2015.
- [120] H. Sun, C. Geng, and S. A. Jafar, “Topological interference management with alternating connectivity,” *IEEE International Symposium on Information Theory - Proceedings*, no. 1, pp. 399–403, 2013.
- [121] X. Yi and G. Caire, “Topological interference management with decoded message passing: A polyhedral approach,” *IEEE International Symposium on Information Theory - Proceedings*, pp. 2800–2804, 2017.
- [122] N. Naderializadeh, A. El Gamal, and A. S. Avestimehr, “Topological interference management with just retransmission: What are the ‘Best’ topologies?” *IEEE International Conference on Communications*, vol. 2015-Septe, pp. 4113–4119, 2015.
- [123] H. Sun and S. A. Jafar, “Topological Interference Management with Multiple Antennas,” pp. 1767–1771, 2014.
- [124] Heecheol Yang; Navid Naderializadeh; A. Salman Avestimehr; Jungwoo Lee, “Topological Interference Management With Reconfigurable Antennas,” *Proc. IEEE Int. Symp. Inform. Theory (ISIT)*, vol. 65, no. 11, pp. 1767–1771, 2014.



- [125] X. Yi and D. Gesbert, “Topological Interference Management With Transmitter Cooperation,” *IEEE Transactions on Information Theory*, vol. 61, no. 11, pp. 6107–6130, 2015.
- [126] R. Y. Chang, Z. Tao, J. Zhang, and C. J. Kuo, “A Graph Approach to Dynamic Fractional Frequency Reuse ( FFR ) in Multi-Cell OFDMA Networks,” 2009.
- [127] Z. Xu, S. Member, G. Y. Li, and F. Member, “Throughput and Optimal Threshold for FFR Schemes in OFDMA Cellular Networks,” vol. 11, no. 8, pp. 2776–2785, 2012.
- [128] A. Blasiak, R. Kleinberg, and E. Lubetzky, “Index coding via linear programming,” *arXiv preprint arXiv:1004.1379*, 2010.



FOLIO ADMINISTRATIF

THESE DE L'UNIVERSITE DE LYON OPEREE AU SEIN DE L'INSA LYON

NOM : KALLAM

DATE de SOUTENANCE : 28/09/2021

Prénoms : Hassan

TITRE : Gestion d'Interférence Topologique pour les Réseaux Sans Fil Multi-utilisateurs

NATURE : Doctorat

Numéro d'ordre : 2021LYSEI062

Ecole doctorale : Électronique, Électrotechnique et Automatique

Spécialité : Traitement du Signal et de l'Image

**RESUME :**

La gestion d'interférence topologique (de l'Anglais: Topological Interference Management - TIM) permet l'étude des degrés de liberté (de l'Anglais: Degrees of Freedom - DoF) de réseaux sans fils soumis à l'interférence partielle et dont la connaissance de l'état du canal est limitée seulement à la topologie du réseaux, autrement dit, quels liens interférents sont faibles et quels sont forts.

Dans ce manuscrit de thèse, nous considérons l'application de TIM pour les réseaux cellulaires d'une dimension (1D) linéaires et les réseaux cellulaires de deux dimensions (2D) hexagonales. Nous considérons le cas des utilisateurs uniformément distribués dans chaque cellule, ce qui donne une distribution continue d'utilisateurs. Ceci nous permet d'étudier la performance des classes d'utilisateurs au contraire des positions des utilisateurs individuels, comme a été fait auparavant. Nous considérons aussi la construction de la topologie au travers de l'analyse des seuils de l'interférence. Contrairement aux travaux existents nous utilisons TIM au niveau des classes des utilisateurs, ce qui nous permet de trouver la performance système en DoF indépendante de la position précise de chaque utilisateur. Ensuite, après avoir proposé un schéma de coloration fractionnaire des graphes resultants, pouvant atteindre la solution optimale de DoF, un compromis entre DoF et rapport signal sur interférence (de l'Anglais: Signal to Interference Ratio - SIR) est proposé.

Cette thèse propose également une nouvelle approche pour construire une topologie d'interférence pour le problème TIM unicast des réseaux sans fil multi-utilisateurs. Fondée sur notre approche de construction de topologie d'interférence, nous pouvons évaluer la limite théorique des taux atteignables, dans le régime rapport signal sur bruit (de l'Anglais: Signal to Noise Ratio - SNR) asymptotique, pour le réseau sans fil sous-jacent et pas seulement pour sa représentation topologique d'interférence. Cette nouvelle approche nous permet de traiter le régime de SNR fini et pas seulement le régime SNR asymptotique avec l'analyse DoF. Un nouveau paramètre liée au seuil d'interférence, indépendant du SNR, est proposé et nous évaluons les débits symétriques réalisables du réseau sans fil, à la fois en régime SNR fini et en régime SNR asymptotique. Ensuite, nous présentons les bornes supérieures sur ce nouveau paramètre de seuil d'interférence normalisé pour les topologies d'interférence ayant une faisabilité en demi-DoF (de l'Anglais: Half-DoF-feasible), en considérant à la fois une allocation de ressources orthogonale et l'alignement d'interférence (de l'Anglais: Interference Alignment - IA). Ces limites spécifient si une topologie d'interférence donnée réalisable en demi-DoF peut être, en termes de taux réalisable, la meilleure topologie ou non. En utilisant ce résultat, nous limitons l'espace de recherche dans la plage de paramètres du seuil d'interférence normalisée, pour trouver des topologies d'interférence réalisables à demi-DoF ayant la possibilité d'être les meilleures topologies en termes de taux réalisable.

Enfin, cette thèse considère une étude de cas sur le TIM pour les réseaux sans fil à petite échelle, dans laquelle, nous considérons le problème TIM pour les réseaux à quatre utilisateurs en employant notre approche de construction de topologie d'interférence proposée. Ensuite, nous appliquons l'analyse des débits réalisables, proposée dans le cadre de la nouvelle approche de construction de topologie d'interférence, pour toutes les topologies d'interférence réalisables à demi-DoF, à la fois par partage orthogonal et IA, dans le problème TIM de réseaux sans fil à quatre utilisateurs.

**MOTS-CLÉS :** Gestion d'interférence topologique, réseaux sans fil, topologie d'interférence, degrés de liberté, seuil d'interférence, débits atteignables

Laboratoire (s) de recherche : CITI

Directeur de thèse: Jean-Marie GORCE

Président de jury :

Composition du jury : Florian KALTENBERGER, Iñaki ESNAOLA, Laurent CLAVIER, Ghaya REKAYA-BEN OTHMAN, Jean-Marie GORCE, Leonardo SAMPAIO CARDOSO