



**HAL**  
open science

# Inventory Routing Problem: Managing demand and travelling time uncertainties

Faycal Touzout

► **To cite this version:**

Faycal Touzout. Inventory Routing Problem: Managing demand and travelling time uncertainties. Business administration. Université de Lyon, 2021. English. NNT : 2021LYSEI064 . tel-03675207

**HAL Id: tel-03675207**

**<https://theses.hal.science/tel-03675207v1>**

Submitted on 23 May 2022

**HAL** is a multi-disciplinary open access archive for the deposit and dissemination of scientific research documents, whether they are published or not. The documents may come from teaching and research institutions in France or abroad, or from public or private research centers.

L'archive ouverte pluridisciplinaire **HAL**, est destinée au dépôt et à la diffusion de documents scientifiques de niveau recherche, publiés ou non, émanant des établissements d'enseignement et de recherche français ou étrangers, des laboratoires publics ou privés.



N°d'ordre NNT : 2021LYSEI064

**THESE de DOCTORAT DE L'UNIVERSITE DE LYON**  
opérée au sein de  
**INSA Lyon**

**Ecole Doctorale N°512**  
**Ecole Doctorale Informatique et Mathématiques de Lyon**

**Spécialité : Génie Industriel**

Soutenue publiquement le 08/10/2021, par :  
**Fayçal Atik Touzout**

---

**Inventory routing problem :  
Gestion des incertitudes liées à la  
demande et aux temps de trajets**

---

Devant le jury composé de :

Nabil Absi, Professeur, Ecole des Mines de Saint-Etienne  
Marc Sevaux, Professeur des Universités, Université Bretagne Sud  
Nadia Brauner, Professeur des Universités, Université Grenoble Alpes  
Maxime Ogier, Maître de conférences, Université de Lille  
Khaled Hadj-Hamou, Professeur des Universités, INSA Lyon  
Anne-Laure Ladier, Maître de conférences, INSA Lyon

Rapporteur  
Rapporteur  
Examinatrice  
Examineur  
Directeur de thèse  
Co-encadrante

## Département FEDORA – INSA Lyon - Ecoles Doctorales

SIGLE	ECOLE DOCTORALE	NOM ET COORDONNEES DU RESPONSABLE
<b>CHIMIE</b>	<b>CHIMIE DE LYON</b> <a href="https://www.edchimie-lyon.fr">https://www.edchimie-lyon.fr</a> Sec. : Renée EL MELHEM Bât. Blaise PASCAL, 3e étage secretariat@edchimie-lyon.fr	<b>M. Stéphane DANIELE</b> C2P2-CPE LYON-UMR 5265 Bâtiment F308, BP 2077 43 Boulevard du 11 novembre 1918 69616 Villeurbanne <a href="mailto:directeur@edchimie-lyon.fr">directeur@edchimie-lyon.fr</a>
<b>E.E.A.</b>	<b>ÉLECTRONIQUE, ÉLECTROTECHNIQUE, AUTOMATIQUE</b> <a href="https://edeea.universite-lyon.fr">https://edeea.universite-lyon.fr</a> Sec. : Stéphanie CAUVIN Bâtiment Direction INSA Lyon Tél : 04.72.43.71.70 secretariat.edeea@insa-lyon.fr	<b>M. Philippe DELACHARTRE</b> INSA LYON Laboratoire CREATIS Bâtiment Blaise Pascal, 7 avenue Jean Capelle 69621 Villeurbanne CEDEX Tél : 04.72.43.88.63 <a href="mailto:philippe.delachartre@insa-lyon.fr">philippe.delachartre@insa-lyon.fr</a>
<b>E2M2</b>	<b>ÉVOLUTION, ÉCOSYSTÈME, MICROBIOLOGIE, MODÉLISATION</b> <a href="http://e2m2.universite-lyon.fr">http://e2m2.universite-lyon.fr</a> Sec. : Sylvie ROBERJOT Bât. Atrium, UCB Lyon 1 Tél : 04.72.44.83.62 secretariat.e2m2@univ-lyon1.fr	<b>M. Philippe NORMAND</b> Université Claude Bernard Lyon 1 UMR 5557 Lab. d'Ecologie Microbienne Bâtiment Mendel 43, boulevard du 11 Novembre 1918 69 622 Villeurbanne CEDEX <a href="mailto:philippe.normand@univ-lyon1.fr">philippe.normand@univ-lyon1.fr</a>
<b>EDISS</b>	<b>INTERDISCIPLINAIRE SCIENCES-SANTÉ</b> <a href="http://ediss.universite-lyon.fr">http://ediss.universite-lyon.fr</a> Sec. : Sylvie ROBERJOT Bât. Atrium, UCB Lyon 1 Tél : 04.72.44.83.62 secretariat.ediss@univ-lyon1.fr	<b>Mme Sylvie RICARD-BLUM</b> Institut de Chimie et Biochimie Moléculaires et Supramoléculaires (ICBMS) - UMR 5246 CNRS - Université Lyon 1 Bâtiment Raulin - 2ème étage Nord 43 Boulevard du 11 novembre 1918 69622 Villeurbanne Cedex Tél : +33(0)4 72 44 82 32 <a href="mailto:sylvie.ricard-blum@univ-lyon1.fr">sylvie.ricard-blum@univ-lyon1.fr</a>
<b>INFOMATHS</b>	<b>INFORMATIQUE ET MATHÉMATIQUES</b> <a href="http://edinfomaths.universite-lyon.fr">http://edinfomaths.universite-lyon.fr</a> Sec. : Renée EL MELHEM Bât. Blaise PASCAL, 3e étage Tél : 04.72.43.80.46 infomaths@univ-lyon1.fr	<b>M. Hamamache KHEDDOUCI</b> Université Claude Bernard Lyon 1 Bât. Nautibus 43, Boulevard du 11 novembre 1918 69 622 Villeurbanne Cedex France Tél : 04.72.44.83.69 <a href="mailto:hamamache.kheddouci@univ-lyon1.fr">hamamache.kheddouci@univ-lyon1.fr</a>
<b>Matériaux</b>	<b>MATÉRIAUX DE LYON</b> <a href="http://ed34.universite-lyon.fr">http://ed34.universite-lyon.fr</a> Sec. : Yann DE ORDENANA Tél : 04.72.18.62.44 yann.de-ordenana@ec-lyon.fr	<b>M. Stéphane BENAYOUN</b> Ecole Centrale de Lyon Laboratoire LTDS 36 avenue Guy de Collongue 69134 Ecully CEDEX Tél : 04.72.18.64.37 <a href="mailto:stephane.benayoun@ec-lyon.fr">stephane.benayoun@ec-lyon.fr</a>
<b>MEGA</b>	<b>MÉCANIQUE, ÉNERGÉTIQUE, GÉNIE CIVIL, ACOUSTIQUE</b> <a href="http://edmega.universite-lyon.fr">http://edmega.universite-lyon.fr</a> Sec. : Stéphanie CAUVIN Tél : 04.72.43.71.70 Bâtiment Direction INSA Lyon mega@insa-lyon.fr	<b>M. Jocelyn BONJOUR</b> INSA Lyon Laboratoire CETHIL Bâtiment Sadi-Carnot 9, rue de la Physique 69621 Villeurbanne CEDEX <a href="mailto:jocelyn.bonjour@insa-lyon.fr">jocelyn.bonjour@insa-lyon.fr</a>
<b>ScSo</b>	<b>ScSo*</b> <a href="https://edsciencessociales.universite-lyon.fr">https://edsciencessociales.universite-lyon.fr</a> Sec. : Mélina FAVETON INSA : J.Y. TOUSSAINT Tél : 04.78.69.77.79 melina.faveton@univ-lyon2.fr	<b>M. Christian MONTES</b> Université Lumière Lyon 2 86 Rue Pasteur 69365 Lyon CEDEX 07 <a href="mailto:christian.montes@univ-lyon2.fr">christian.montes@univ-lyon2.fr</a>

\*ScSo : Histoire, Géographie, Aménagement, Urbanisme, Archéologie, Science politique, Sociologie, Anthropologie

INVENTORY ROUTING PROBLEM: MANAGING DEMAND AND  
TRAVELLING TIME UNCERTAINTIES

FAYÇAL A. TOUZOUT

Fayçal A. Touzout. *Inventory routing problem: Managing demand and travelling time uncertainties*

## RÉSUMÉ

---

La gestion partagée des approvisionnement (*Vendor Management Inventory* ou VMI) change la division traditionnelle des décisions au sein de la chaîne logistique : c'est le fournisseur qui contrôle les approvisionnements de ses clients en décidant quand et de combien réapprovisionner leurs stocks. Basé sur la confiance, le VMI bénéficie autant au fournisseur qu'à ses clients : le fournisseur réduit son coût de transport en regroupant les différentes livraisons, tandis que le client n'a pas besoin de dédier des ressources à la planification de ses approvisionnements.

Le fournisseur doit ainsi gérer de façon intégrée ses livraisons pour minimiser ses coûts de transport, et les stocks de ses clients pour satisfaire leur niveau de service attendu. Le problème qui en résulte est appelé *Inventory Routing Problem* (IRP). Il intègre deux problèmes opérationnels de la *supply chain* : la gestion des stocks et le transport. Dans le réseau IRP, un fournisseur est chargé de gérer le stock et la livraison d'un ensemble de clients, pour satisfaire leurs demandes sur un horizon temporel donné. L'objectif du décideur est de déterminer, pour chaque période de l'horizon temporel, si un client doit être réapprovisionné, avec quelle quantité et selon quel itinéraire, en optimisant à la fois les coûts de stockage et les coûts de transport.

Un défi commun à toutes les opérations de la chaîne logistique est la gestion de l'incertitude ; cela s'applique également à l'IRP. En effet, la multiplicité des acteurs et des paramètres de l'IRP augmente le nombre de sources d'incertitude, qui peuvent être liées aux problèmes de gestion des stocks comme aux problèmes de transport. La demande des clients peut changer de manière inattendue ; un chauffeur peut être confronté à un embouteillage imprévu, ou découvrir en arrivant chez un client que la place de stationnement de livraison est indisponible. Ainsi, en augmentant considérablement le temps de déplacement et de service, ou en modifiant la demande, les plannings du décideur peuvent devenir irréalisables.

Les manières les plus courantes de prendre en compte les incertitudes dans la littérature sont les approches *a priori*. Les approches *a priori* gèrent les incertitudes de manière proactive, c'est-à-dire en construisant des plannings de réapprovisionnement robustes (qui resteront réalisables face à un large éventail d'événements) ou par optimisation stochastique (en optimisant l'objectif en espérance), combinés à des stratégies de réparation si les solutions sont infaisables. Le principal inconvénient de telles approches est le conservatisme de leurs solutions, qui les rend coûteuses, surtout lorsque la plage de variabilité des paramètres incertains est grande.

L'objectif de cette thèse est de rompre avec la tendance de la littérature à gérer les incertitudes majoritairement *a priori*, avec des approches d'optimisation stochastiques et robustes. Pour ce faire, nous nous concentrons sur les sources d'incertitude les plus courantes dans les situations réelles : la demande des clients et les temps de trajets.

Dans des situations réelles, il est rare qu'un client passe commande en donnant une distribution probabiliste ou un intervalle. Les valeurs sont plutôt basées sur des données historiques, et sujettes à modification à tout moment dans l'horizon temporel. Par conséquent, la façon la plus naturelle de gérer une telle incertitude est d'attendre qu'elle soit révélée et de procéder à une réparation des plannings établis initialement ou bien à une ré-optimisation complète.

Dans la littérature de l'IRP, les incertitudes sont rarement gérées par une approche de ré-optimisation. Cette rareté pourrait s'expliquer par le fait que la ré-optimisation peut s'avérer inadaptée aux problèmes de transport. Dans le cas du *Vehicle Routing Problem* (VRP), des chercheurs affirment que du point de vue des coûts, ré-optimiser les décisions de tournées une fois les incertitudes révélées est une meilleure alternative théorique aux approches *a priori*, mais résoudre un VRP avec ré-optimisation reste un problème difficile. Par ailleurs, les approches *a priori* ont l'avantage de préserver la structure des solutions, ce qui n'est pas le cas pour la ré-optimisation. Ces limitations concernent cependant moins l'IRP que d'autres problèmes de transport : bien que le transport soit une composante importante, les autres composantes fournissent des variables d'ajustement supplémentaires, telles que sa dimension multipériode, la disponibilité d'un stock ou un éventuel transbordement. La possibilité d'anticiper une livraison, ainsi que le tampon fourni par les stocks tant chez le fournisseur que chez son client donnent ainsi une flexibilité supplémentaire pour réagir aux incertitudes. Par conséquent, nous pensons que des approches *a posteriori* pour l'IRP devraient être étudiées.

Une stratégie *a posteriori* consiste à réparer la solution initiale en y apportant de petites modifications pour la rendre réalisable. Par exemple, si la demande d'un client augmente un jour où aucun approvisionnement n'était prévu pour lui, et que son niveau de stock n'est pas suffisant pour couvrir l'augmentation de la demande, il aura besoin d'une visite supplémentaire dans la solution réparée. Si les véhicules utilisés pour cette période sont déjà à pleine capacité dans la solution initiale, le décideur doit choisir entre insérer ce client à la place d'un autre dans l'itinéraire ou utiliser un autre véhicule pour faire un réapprovisionnement direct. La difficulté ici est le compromis entre la faisabilité des solutions et leur rentabilité ; et lorsque davantage de demandes de clients changent, l'ensemble des possibilités augmente de façon exponentielle, ce qui rend les stratégies de réparation difficiles à développer. Une autre approche est une ré-optimisation complète de la solution initiale, à partir du moment où l'événement inattendu

est révélé jusqu'à la fin de l'horizon temporel. L'inconvénient de cette approche est que la nouvelle solution peut être complètement différente de la première. Cela crée des problèmes d'organisation : par exemple, si le nouveau plan nécessite plus de véhicules, et donc plus de chauffeurs, ils peuvent être difficiles à trouver au dernier moment. De plus, si le fournisseur change constamment sa date de livraison, le client peut perdre confiance et chercher un autre fournisseur. De telles situations entraînent des surcoûts très difficiles à quantifier : le décideur peut donc privilégier des solutions « stables » lors de la ré-optimisation.

Mais comment savoir qu'une solution est stable? Dans la littérature, un planning stable est défini comme un planning qui « s'écarte le moins possible de l'original ». Cette définition étant très générale, son application dans le cas de l'IRP n'est pas évidente. Par exemple, considérons un planning qui réapprovisionne cinq clients selon une certaine séquence un jour donné; deux solutions sont proposées pour faire face à une augmentation de la demande d'un client. La première solution maintient le même ensemble de clients dans la même séquence mais les réapprovisionne avec des quantités qui diffèrent de la solution initiale. Une autre solution supprime un client de l'itinéraire et modifie la séquence. Parmi ces deux solutions; laquelle fournit le plus petit écart, et est donc la plus stable? Il n'y a pas de réponse simple.

Cela nous amène à notre première question de recherche :

*Comment mesurer la stabilité de l'IRP en cas d'incertitude de la demande ?*

En ce qui concerne l'incertitude des temps de trajets, une approche *a priori* semble appropriée, car un intervalle de temps peut être une bonne représentation du temps nécessaire pour se déplacer d'un endroit à un autre. L'exemple le plus courant s'obtient avec une recherche rapide sur n'importe quel logiciel de navigation GPS. Ainsi, contrairement à la demande, la source de la volatilité temporelle n'est pas imprévisible mais dépend de paramètres déterministes.

On peut distinguer deux types de temps différents dans les problèmes de transport tels que l'IRP : le temps de trajet et le temps de service. Dans cette thèse, on ne s'intéresse qu'au premier. La volatilité des temps de trajets est généralement due au fait que les IRP évoluent dans un contexte de logistique urbaine, où les conditions de circulation peuvent varier au cours de la journée. Cette volatilité n'est pas aléatoire mais dépend plutôt du temps. Cela signifie que le temps de trajet ne dépend pas seulement des lieux de départ et d'arrivée, mais dépend également de l'heure de départ.

L'incertitude liée aux temps de trajets est donc gérée *a priori* mais de manière déterministe, en les considérant comme *time dependent*. Cependant, les problèmes de transport *time dependent* ont tendance à



être plus difficiles à résoudre que leur équivalent de base. Cela nous amène à notre deuxième question de recherche :

*Comment intégrer l'aspect time dependent dans l'IRP et le résoudre efficacement ?*

Un chapitre est consacré à la première question de recherche. Une revue de la littérature sur les approches de réoptimisation pour les problèmes NP-difficiles, en général, et les problèmes de séquençage tels que les problèmes d'ordonnancement et de routage, en particulier, est menée. La littérature montre que les problèmes de réoptimisation sont généralement aussi difficiles que les problèmes initiaux, et que leurs solutions optimales respectives peuvent être complètement différentes. Par conséquent, une revue des mesures de stabilité dans la littérature de sous-problèmes de l'IRP (tels que le transport et la gestion de stocks) et de problèmes de séquençage similaires (tels que l'ordonnancement) est proposée. Une partie de ces mesures sont choisies pour être adaptées pour l'IRP. Le problème de réoptimisation par rapport à l'objectif initial – le coût total composé des coûts de possession et de transport – est formulé. Les mesures de stabilité sont adaptées et leurs avantages et inconvénients discutés; certaines sont formulées mathématiquement et leur corrélation et leur impact par rapport au coût sont étudiés. Les expérimentations numériques montrent que pour une grande partie des instances résolues, il existe une forte corrélation entre les mesures, c'est-à-dire qu'optimiser une mesure revient à optimiser l'autre, et que l'impact des solutions stables sur le coût est plutôt faible.

Deux chapitres sont consacrés à la deuxième question de recherche et répondent aux deux parties de la question, respectivement, *Comment intégrer l'aspect time dependent dans l'IRP ?* et le *Comment résoudre le TD-IRP efficacement ?*. Le premier de ces deux chapitres propose une revue de la littérature des variantes de l'IRP avec le temps de trajets comme préoccupation principale. On constate ainsi qu'il y a très peu de littérature sur le *time dependent* IRP (TD-IRP). Ainsi, on se concentre sur des problèmes de transport pur. En partant de l'abondante littérature des problèmes de transport *time dependent*, quatre formulations mathématiques pour le TD-IRP basées sur une discrétisation différente du temps sont proposées. Un nouveau benchmark est généré, inspiré des benchmarks de la littérature de l'IRP et du *Time Dependent Travelling Salesman Problem* (TD-TSP). La comparaison des performances de quatre formulations différentes du TD-IRP montre qu'une formulation se détache grâce à sa capacité à résoudre des instances plus grandes. Le second chapitre consacré à la deuxième question de recherche, étudie la pertinence de considérer les temps de trajets comme *time dependent*. Deux critères sont considérés : les gains en termes de coût de la solution et la complexité empirique de

résoudre des problèmes TD-IRP. Les résultats des expérimentations numériques montrent que considérer le TD-IRP apporte des gains en termes de coût, mais rend le problème beaucoup plus difficile à résoudre. Inspirée par les résultats de cette étude et des structures optimales des solutions du TD-IRP, une matheuristique est proposée. La matheuristique alloue dans un premier temps l'ensemble des clients à visiter à une période de l'horizon temporel. Ensuite, pour chaque période, un TD-TSP est résolu pour déterminer la séquence de visite. Les résultats montrent que la matheuristique est efficace.

Enfin, un chapitre de conclusions résume les contributions et liste des perspectives de recherche à moyen et long terme.



## PUBLICATIONS

---

### JOURNAL ARTICLES

- Lefever, Wouter, **Touzout, Faycal A.**, Khaled Hadj-Hamou, and El-Houssaine Aghezzaf (2021). « Benders' decomposition for robust travel time-constrained inventory routing problem. » In: *International Journal of Production Research* 59.2, pp. 342–366.
- Faycal A. Touzout**, Anne-Laure Ladier, and Khaled Hadj-Hamou (2021a). « An assign-and-route matheuristic for the time-dependent Inventory Routing Problem. » In: *European Journal of Operational Research*.
- Faycal A. Touzout**, Anne-Laure Ladier, and Khaled Hadj-Hamou (2021b). « Modelling and comparison of stability metrics for a re-optimisation approach of the Inventory Routing Problem under demand uncertainty. » In: *EURO Journal on Transportation and Logistics* 10, p. 100050.

### INTERNATIONAL CONFERENCES WITH PROCEEDINGS

- Touzout, Faycal A.**, Anne-Laure Ladier, and Khaled Hadj-Hamou (2020b). « Time-dependent travel-time constrained Inventory Routing Problem. » In: *International Conference on Computational Logistics*. Springer, pp. 151–166.

### COMMUNICATIONS WITHOUT PROCEEDINGS

- Touzout, Faycal A.**, Anne-Laure Ladier, and Khaled Hadj-Hamou (2020a). *Inventory Routing Problem: ré-optimisation sous incertitudes*. ROADEF 2020.
- Touzout, Faycal A.**, Anne-Laure Ladier, and Khaled Hadj-Hamou (2021). *Formulations mathématiques pour le TD-IRP*. ROADEF 2021.



# CONTENTS

---

INTRODUCTION	1
1 INVENTORY ROUTING PROBLEM AND UNCERTAINTY	3
1.1 Inventory Routing Problem . . . . .	4
1.1.1 Mathematical formulation of the IRP . . . . .	7
1.1.2 An illustrative example . . . . .	9
1.1.3 Solving method . . . . .	10
1.2 Uncertainty in the IRP literature . . . . .	10
1.2.1 Sources of uncertainty . . . . .	12
1.2.2 Approaches to handle uncertainty . . . . .	14
1.3 Dissertation objectives . . . . .	17
1.3.1 Demand uncertainty . . . . .	17
1.3.2 Travelling time uncertainty . . . . .	19
1.3.3 Structure of the dissertation . . . . .	20
2 RE-OPTIMISATION AND STABILITY	23
2.1 Literature review . . . . .	23
2.1.1 Solving re-optimisation problems . . . . .	24
2.1.2 Stability as a re-optimisation criterion . . . . .	27
2.2 Cost-based re-optimisation . . . . .	33
2.3 Adaptation and mathematical formulation of stability metrics . . . . .	35
2.3.1 Sequence preservation . . . . .	35
2.3.2 Visit deviation . . . . .	38
2.3.3 Quantity received deviation . . . . .	40
2.3.4 Clients re-allocation . . . . .	44
2.3.5 Edit distance . . . . .	44
2.3.6 Delivery system modification . . . . .	45
2.3.7 Visiting time deviation . . . . .	46
2.3.8 A qualitative discussion . . . . .	46
2.4 Comparison of stability metrics . . . . .	47
2.4.1 Benchmark . . . . .	48
2.4.2 A dominance function . . . . .	49
2.4.3 Experimental results and discussion . . . . .	51
2.5 Conclusion . . . . .	57
2.5.1 Contributions . . . . .	57
2.5.2 Perspectives . . . . .	57
3 TIME DEPENDENT INVENTORY ROUTING PROBLEM	59
3.1 Literature review . . . . .	59
3.1.1 IRP with travelling time focus . . . . .	59
3.1.2 Time dependent routing problems . . . . .	61
3.2 Problem description and mathematical formulations . . . . .	63
3.2.1 First In First Out property . . . . .	65

3.2.2	Four mathematical formulations . . . . .	67
3.2.3	An illustrative example . . . . .	76
3.3	A new benchmark for the TD-IRP . . . . .	81
3.3.1	Inventory management data . . . . .	82
3.3.2	Time dependent travelling time functions . . . . .	84
3.3.3	Travel-time constraint . . . . .	84
3.4	Comparison of the four formulations . . . . .	87
3.5	Conclusion . . . . .	90
3.5.1	Contributions . . . . .	90
3.5.2	Perspectives . . . . .	90
4	SOLVING THE TD-IRP . . . . .	93
4.1	Investigating the relevance of TD-IRP . . . . .	93
4.1.1	Numerical experiments . . . . .	94
4.1.2	Discussion . . . . .	97
4.2	An assign-and-route matheuristic for the TD-IRP . . . . .	100
4.2.1	Description of the matheuristic procedure . . . . .	100
4.2.2	Numerical experiments . . . . .	102
4.2.3	Discussion . . . . .	106
4.3	Conclusion . . . . .	109
4.3.1	Contributions . . . . .	109
4.3.2	Perspectives . . . . .	109
5	CONCLUSION . . . . .	111
	BIBLIOGRAPHY . . . . .	117

## LIST OF FIGURES

---

Figure 1.1	A summary of the different variants of the IRP in the literature . . . . .	5
Figure 1.2	A solution for an IRP example . . . . .	11
Figure 1.3	A summary of the different sources of uncertainties treated in the IRP literature . . . . .	13
Figure 1.4	A summary of the dissertation structure . . . . .	20
Figure 2.1	A solution for an IRP example with cost re-optimisation . . . . .	36
Figure 2.2	A solution for an IRP example with sequence preservation re-optimisation . . . . .	39
Figure 2.3	A solution for an IRP example with visit deviation re-optimisation . . . . .	41
Figure 2.4	A solution for an IRP example with quantity deviation re-optimisation . . . . .	43
Figure 2.5	A representation of the distribution of the gap in the cost for the different stability metrics . . . . .	53
Figure 3.1	An example of the transformation of a constant piece-wise function into a linear piece-wise one . . . . .	66
Figure 3.2	An illustration of the decomposition of a period of the time horizon with breakpoints . . . . .	72
Figure 3.3	A representation of the travelling time functions between the locations of the network . . . . .	77
Figure 3.4	The transportation sequence of formulations 1 and 2 for a TD-IRP example . . . . .	78
Figure 3.5	The transportation sequence of formulation 3 for a TD-IRP example . . . . .	79
Figure 3.6	The transportation sequence of formulation 4 for a TD-IRP example . . . . .	80
Figure 3.7	A travelling time function between two random locations for different time discretisations . . . . .	85
Figure 4.1	Procedure for optimal TD-IRP solutions vs. constant travelling time solutions re-solved in a time dependent environment . . . . .	94
Figure 4.2	Distribution in gap between optimal TD-IRP solutions and constant travelling time solutions re-solved in a time dependent environment . . . . .	98
Figure 4.3	Distribution in gap between the lower bound of optimal TD-IRP solutions and the upper bound of constant travelling time solutions re-solved in a time dependent environment . . . . .	99



Figure 4.4	Description of the procedure of the proposed matheuristic . . . . .	101
Figure 4.5	Distribution in gap between optimal TD-IRP solutions and solutions of the proposed matheuristic . . . . .	107
Figure 4.6	Distribution in gap between the lower bound of optimal TD-IRP solutions and upper bound of solutions of the proposed matheuristic . . .	108

## LIST OF TABLES

Table 1.1	A representation of an IRP instance's data . . .	9
Table 1.2	A solution of an IRP example . . . . .	10
Table 1.3	An overview of the IRP under uncertainty literature 1/2 . . . . .	15
Table 1.4	An overview of the IRP under uncertainty literature 2/2 . . . . .	16
Table 2.1	A summary of the stability metrics proposed in the literature . . . . .	32
Table 2.2	A representation of an event for the an instance	33
Table 2.3	A synthesis of the parameters of stability metrics proposed for the IRP . . . . .	47
Table 2.4	A description of the benchmark set of the numerical experiments . . . . .	48
Table 2.5	A description of the different event scenarios .	49
Table 2.6	A representation of the structure of the comparison matrix . . . . .	50
Table 2.7	An illustration of the results of an example instance . . . . .	51
Table 2.8	A representation of the dominance results between the stability metrics . . . . .	51
Table 2.9	A representation of the distribution of the gap in the cost for the stability metrics . . . . .	52
Table 2.10	An illustration of the number of re-optimisation instances solved optimally . . . . .	54
Table 2.11	A comparison of the performances for instances with constant demand over the time horizon vs. v variable demand . . . . .	56
Table 3.1	A summary of the time dependent routing literature . . . . .	64
Table 3.2	An example of the FIFO satisfaction property depending on the departure time between two time steps . . . . .	66
Table 3.3	A synthesis of the properties of the four mathematical formulations . . . . .	75
Table 3.4	A representation of the data for an example instance . . . . .	76
Table 3.5	The values of the optimal variables of an example instance . . . . .	81
Table 3.6	Results of the comparison of the four proposed formulations . . . . .	88

Table 4.1	Result of the comparison between optimal TDIRP solutions and constant travelling time solutions re-solved in a time dependent environment 1/2	95
Table 4.2	Result of the comparison between optimal TDIRP solutions and constant travelling time solutions re-solved in a time dependent environment 2/2	96
Table 4.3	A representation of the matheuristics performances 1/2 . . . . .	104
Table 4.4	A representation of the matheuristics performances 2/2 . . . . .	105

## LIST OF ALGORITHMS

---

1.1	A description of the branch-and-cut procedure . . . . .	12
2.1	Description of the procedure for the generation of an event	49
2.2	A description of the solving procedure for the numerical experiments . . . . .	50
3.1	A description of the FIFO transformation procedure . .	67
3.2	A procedure for possible time dependent vertices generation . . . . .	70
3.3	A procedure for the time dependent graph cleaning . .	71
3.4	A procedure for the generation of the time dependent variables . . . . .	71
3.5	A procedure for the generation of the inventory management data . . . . .	83
3.6	An Iterated Local Search for the TD-TSP . . . . .	86
4.1	A description of the matheuristic procedure . . . . .	103



## INTRODUCTION

---

Vendor management inventory (VMI) changes the traditional division of decisions within the supply chain: the supplier controls the inventory of its clients by deciding when and how much to replenish their inventories. Built on trust, the VMI system is a win-win situation: the supplier is able to reduce its transportation cost by consolidating the different deliveries, whereas the client does not need dedicated resources to schedule its supplies.

The VMI supplier must thus manage both its deliveries to incur the least transportation cost, and the clients' inventory to satisfy their expected service level. The resulting problem is called the inventory routing problem (IRP). It integrates two operational problems of the supply chain: inventory management and routing. In the IRP network, a supplier is responsible for managing the inventory and the distribution of a set of clients, to satisfy their demands on a given time horizon. The objective of the decision-maker is to decide, for each period of the time horizon, whether a client should be replenished, with which quantity and following which route, optimising both the inventory and transportation costs.

A common challenge faced by all supply chain operations is the management of uncertainty; this also applies to the IRP. Indeed, the multiplicity of actors and parameters of the IRP makes the range of uncertainty wide, as they can be related to both inventory management and routing components. The clients' demand may change unexpectedly; a driver may be confronted to an unexpected traffic jam, or when arriving at a client's location, the delivery parking slot might be unavailable. By drastically increasing the travelling and service time, or modifying the demand, the decision-maker's plans may become unfeasible.

The most common ways to take uncertainties into consideration in the literature are *a priori* approaches. The *a priori* approaches manage uncertainties in a proactive way either by making robust replenishment plans, that will be feasible even when faced with a wide range of events or in a stochastic manner by optimising the expected value of the objective combined with repair strategies in case the solutions are infeasible. The main drawback of such approaches is the conservatism of their solutions, which makes them expensive, especially when the range of variability of the uncertain parameters is wide.

However, tackling uncertainties can be done in different fashions. *A posteriori* approaches handle uncertainties once they are revealed through either repair strategies or a full re-optimisation. The drawback of repairing the initial solution is the difficulty to develop strate-

gies that yield feasible solutions without a huge degradation of the solution's cost. Re-optimisation on the other hand can obtain cost-efficient solutions, although such a solution may be completely different from the initial one. This deviation between the two solutions may create organisational issues that lead to additional costs that are very difficult to quantify. Thus it is necessary to propose optimisation metrics that ensure the stability of the initial solution.

Another way of managing uncertainties is to study their sources. Indeed, depending on the data, one can notice that all uncertainties are not unpredictable and that some may depend on deterministic parameters. Therefore, it is possible to lift such uncertainties in an *a priori* but deterministic fashion.

The objective of this dissertation is to tackle the IRP uncertainties by focusing on two of their main sources: the clients' demand and the travelling time. The clients' demand uncertainty is handled through a re-optimisation approach with stability metrics. The travelling time uncertainty is managed in an *a priori* but deterministic fashion by considering it as time dependent.

In [Chapter 1](#), a review of the IRP literature under uncertainty and variants of the IRP where the travelling time is the main focus is carried out and yields two research questions: *how to measure stability in the IRP under demand uncertainty?* and *How to incorporate the time dependent aspect in the IRP and solve it efficiently?*.

[Chapter 2](#) is dedicated to answer the first question, where stability metrics from the literature of sub-problems of the IRP (such as routing and inventory management) or similar sequencing problems (such as scheduling) are re-adapted for the IRP. These metrics are formulated and their correlation and impact on the cost of the solutions are investigated. [Chapter 3](#) and [Chapter 4](#) answer the second question by tackling the Time Dependent IRP (TD-IRP) where travelling times do not only depend on the departure and arrival locations, but on the time of departure as well. [Chapter 3](#) proposes four mathematical formulations for the (TD-IRP) inspired from the rich literature on time dependent routing problems. The four formulations are compared on a new generated benchmark based on benchmarks of the IRP and TD-TSP literature. [Chapter 4](#) investigates the relevance of considering time dependent travelling times by considering two aspects: the gain in cost and the computational complexity. Moreover, a study on the structure of optimal TD-IRP solutions inspires an assign-and-route matheuristic in order to solve large-sized instances.

## INVENTORY ROUTING PROBLEM AND UNCERTAINTY

---

During the last century, the industrial field has seen an exponential evolution which led to a very globalised market of which industries took advantage to exploit new markets and new technologies. However, globalisation engendered a fierce competition for market shares. To gain a considerable advantage over their competitors, companies have mostly focused on manufacturing operations. However, in recent years, due to the development of several concepts and paradigms such as re-configurable manufacturing systems, 3D printing, additive manufacturing... the development threshold of manufacturing operations has almost been reached. Thus, in order for companies to keep improving their competitiveness, logistics and supply chain operations can play a key role.

The "Who's Who in Logistics Guide" by Armstrong & Associates, Inc. estimates that the global logistics market accounts for 10.7% of the world's GDP as of 2019. Transport and inventory holding operations, together, represent more than 70% of that amount (Armstrong & Associates, Inc.", 2020). Therefore, an effective transportation and inventory operations management can provide a major source of competitive advantage. A way to make these operations efficient is to integrate their decision processes. It is in this context that the Vendor Managed Inventory (VMI) emerges.

VMI is a business practice aimed at reducing logistics costs and adding business value (Coelho et al., 2014a). It promises a win-win situation for both the supplier and the client. In a true VMI setting, the supplier has the freedom to plan the replenishment schedule as long as the clients are able to satisfy their demand. This enables suppliers and clients to both optimise the transportation costs and to minimise their inventory cost.

The range of applicability of VMI is quite wide: it goes from the food industry to the distribution of petroleum and liquid gases. It has been applied with success in several known cases. Some of the precursors in the area are Coca Cola to replenish their vending machines (Mangiaracina et al., 2012), the collaboration between Procter & Gamble and Walmart (Harsono, 2013) in the diaper distribution industry or Air Liquide who supplies gas to multiple healthcare centres. (André et al., 2020).

The operational problem raised by the implementation of VMI is to decide when and how much each client should be replenished over a time horizon. This problem is called the Inventory Routing



Problem (IRP).. And just as in any other logistics paradigm or operations, a challenge that can be faced is uncertainties. This aspect has been highlighted last year during the COVID crisis when intensive care hospitalisations increased dramatically and the need for oxygen re-supply spiked. In this chapter we briefly present the IRP in its simplest case and try to identify the gaps in the literature of the IRP under uncertainty.

In [Section 1.1](#), we give a brief overview of the literature of the IRP by presenting the variants existing in the literature, a mathematical formulation and the most commonly used approaches to solve the simplest case of the IRP. [Section 1.2](#) proposes an exhaustive literature of the IRP under uncertainties and identifies its gaps. Finally, [Section 1.3](#) identifies two research questions and gives insights on how these questions will be answered throughout the next chapters of this dissertation.

## 1.1 INVENTORY ROUTING PROBLEM

The origins of the IRP go back to the paper of Bell et al. (1983) where the goal was to automatise the process of delivering liquid gases for the company Air Product. In its simplest case, the IRP is set in a network where a supplier is supposed to deliver goods to its clients, over a time horizon. The objective of the IRP is to decide for each period, whether a client is served, with which quantity, and a route for a single vehicle, while minimising the total cost (e.g. transportation costs, inventory cost or possibly other objectives).

However, the pure IRP is hardly representative of all the situations that can occur in real-life. Other than the deterministic/uncertain context of the data, four types of additional challenges can be faced: challenges related to the satisfaction of the client; challenges related to the vehicles and/or drivers; challenges related to the product; and finally, challenges related to the specifications of the network. We list here some of these requirements and the variants of IRP dedicated to cater for them. [Figure 1.1](#) summarises all these variants.

**CLIENT:** Because of some space limitations, the clients can provide an upper bound of their inventory capacity.

Due to the constraints related to urban deliveries (e.g. rush hours, availability of parking slots...) and to scheduling problems (e.g. workers availability...), the client may require to be served in a certain time interval. The variant of the IRP which meets this requirements is the inventory routing problem with time windows (IRPTW). A systematic review of the IRPTW literature is presented in Delgado et al. (2018).

**VEHICLE:** Vehicles have a limited capacity. This property is taken into consideration in all works related to the IRP. As one capacitated vehicle may not be enough, one variant of the IRP

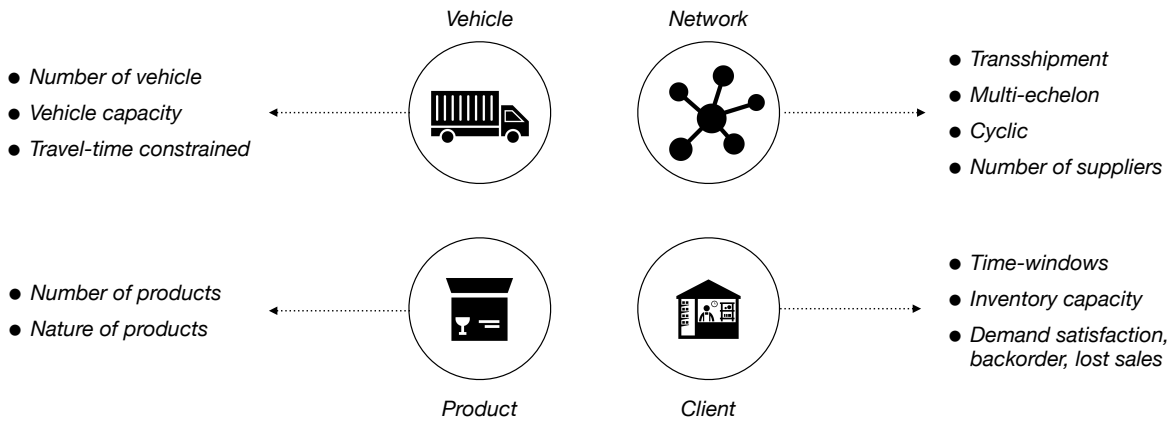

Figure 1.1 – A summary of the different variants of the IRP in the literature

that cater for this problem is the multi-vehicle inventory routing problem.

In order to cater for legal limitations of work hours per day, drivers may be given routes that must be completed in a certain amount of time. The IRP with route duration limit meets this requirement. The most recent work to tackle this problem is Lefever (2018a).

**PRODUCT:** The number of the products handled is a property that the multi-product IRP variant takes into consideration. A relevant work in this context is presented by Mirzapour Al-e-Hashem et al. (2013).

The nature of the product is important in the IRP since it may impose different requirements, mainly related to perishability. In this context, the IRP with lead times, where the clients impose lead times to cater for perishability issues, emerges. Li et al. (2016b) is an example of a study that takes it in consideration. We note that the problem of perishability in the case of a single-product can be handled by imposing a route duration limit.

**NETWORK:** In order to design a network that is efficient in an economical sense, but also ecological, reducing the number of vehicles used to replenish the clients as well as reducing the total travelled distance is primordial (Mirzapour Al-e-Hashem et al., 2013). Therefore, Coelho et al. (2012) introduced a new variant of the IRP, the inventory routing problem with transshipment (IRPT). Transshipment in this case means that the replenishment is not only done from the supplier to a client using an owned vehicle, but can also be done from a client to another client or from the supplier to a client by hiring a subcontractor. A study reports that in addition to the decrease of the overall

cost, transshipment helps diminishing accidents (Timajchi et al., 2019).

The number of suppliers is an additional property of the IRP that can be taken into consideration, by having different suppliers, or by including transshipment, where each client becomes a potential supplier. A recent work in this context is presented in Bertazzi et al. (2019)

Moreover, in order to avoid the challenges that the scheduling in a large time horizon can bring, such as regularity, some suppliers prefer handling the IRP for a smaller time interval that will be reproduced over and over. Hence the periodic/cyclic IRP. Relevant works in this context are presented in Lefever et al. (2016) and Raa et al. (2009).

Finally, to have a globally optimised network, the IRP can be studied in a multi-echelon environment where multiple layers of the supply chain are included: for example, a supplier, the different retailers that the supplier serve and the different clients that the different retailers serve. Recent works in this context are presented in Farias et al. (2021) and Guimarães et al. (2019).

The IRP is known to be an NP-Hard problem (Archetti et al., 2007). Therefore, many scholars dedicate their works to find the most suitable solution approaches for the different variants described above. Scholars proposed exact methods such as mixed integer linear programs, branch-and-cut, branch-and-price and Bender's decomposition algorithms to optimally solve the problem. Due to the hardness of the IRP for large instances, heuristics are also used, such as genetic algorithms, local search based heuristics or hybrid algorithms. Literature reviews dedicated to the different solution approaches for the IRP are presented in Bertazzi et al. (2012, 2013) and Coelho et al. (2014a).

The IRP literature is quite rich. Because the contributions of this dissertation are not related to the mathematical formulation and the solving approaches of the basic IRP, the remaining of this section focuses only on presenting elements from the literature of the IRP that will be used throughout this dissertation. First, a basic mathematical formulation of the IRP based on the formulation of Archetti et al. (2007) is presented. The problem is then illustrated with a simple example. Finally, a branch-and cut procedure for the IRP, that combines state-of-the-art cuts and reformulations, is presented in order to solve the problem efficiently.

### 1.1.1 Mathematical formulation of the IRP

#### 1.1.1.1 Notations

##### DEFINITION SETS:

- $\mathcal{G} = (\mathcal{V}, \mathcal{E})$  is a graph where vertex  $0 \in \mathcal{V}$  represents the supplier,  $\mathcal{V} \setminus \{0\}$  the set of clients and  $\mathcal{E}$  the set of edges.
- $\mathcal{H} = \{0, 1, \dots, |\mathcal{H}|\}$  is a time horizon where  $p \in \mathcal{H}$  represents the index of the period. Note that  $p = 0$  represents the initial state.

##### CLIENT DATA:

- $D_i^t$  is the demand of client  $i \in \mathcal{V} \setminus \{0\}$  at period  $p \in \mathcal{H}$ .
- $I_i^0$  represents the initial inventory (at period  $p = 0$ ) of client  $i \in \mathcal{V} \setminus \{0\}$ .
- $I_i^{\max}$  is the maximum inventory level for client  $i \in \mathcal{V} \setminus \{0\}$ .

##### SUPPLIER DATA:

- $R^p$  is the quantity of products available or produced at supplier  $0 \in \mathcal{V}$  for period  $p \in \mathcal{H}$ .
- $I_0^0$  represents the initial inventory of the supplier.
- $C$  represents the capacity of the vehicle.

##### COSTS:

- $h_i$  is the holding cost paid for each product in the inventory of the client/supplier  $i \in \mathcal{V}$  at the end of period  $p \in \mathcal{H}$ .
- $f(i, j)$  is the travelling distance of edge  $(i, j) \in \mathcal{E}$ .
- $c$  is the cost of going through one distance unit.

#### 1.1.1.2 Variables and mathematical model

- $x_{i,j}^p = 1$  if edge  $(i, j) \in \mathcal{E}$  is travelled by vehicle at period  $p \in \mathcal{H}$ , 0 otherwise.
- $y_i^p = 1$  if client  $i \in \mathcal{V} \setminus \{0\}$  is visited at period  $p \in \mathcal{H}$ , 0 otherwise.
- $I_i^p \in \mathbb{R}$  is the inventory level of client  $i \in \mathcal{V} \setminus \{0\}$  at the end of period  $p \in \mathcal{H}$ .
- $q_i^p \in \mathbb{R}$  is the quantity sent to client  $i \in \mathcal{V} \setminus \{0\}$  at period  $p \in \mathcal{H}$ .

---

**IRP**

---

$$\begin{aligned}
\min \quad & \text{obj}^{\text{IRP}} = c \times \sum_{i \in \mathcal{V}} \sum_{j \in \mathcal{V}, i < j} \sum_{p \in \mathcal{H} \setminus \{0\}} x_{i,j}^p \times f(i,j) + \sum_{i \in \mathcal{V}} \sum_{p \in \mathcal{H}} I_i^p \times h_i \\
\text{s.t} \quad & I_0^p = I_0^{p-1} - \sum_{i \in \mathcal{V} \setminus \{0\}} q_i^p + R^p \quad \forall p \in \mathcal{H} \setminus \{0\} \quad (1) \\
& I_i^p = I_i^{p-1} + q_i^p - D_i^p \quad \forall i \in \mathcal{V} \setminus \{0\}, \forall p \in \mathcal{H} \setminus \{0\} \quad (2) \\
& I_i^p \leq I_i^{\max} \quad \forall i \in \mathcal{V} \setminus \{0\}, \forall p \in \mathcal{H} \setminus \{0\} \quad (3) \\
& q_i^p + I_i^{p-1} \leq I_i^{\max} \quad \forall i \in \mathcal{V} \setminus \{0\}, \forall p \in \mathcal{H} \setminus \{0\} \quad (4) \\
& q_i^p \leq y_i^p \times I_i^{\max} \quad \forall i \in \mathcal{V} \setminus \{0\}, \forall p \in \mathcal{H} \setminus \{0\} \quad (5) \\
& q_0^p \leq y_0^p \times C \quad \forall p \in \mathcal{H} \setminus \{0\} \quad (6) \\
& \sum_{j \in \mathcal{V} \setminus \{0\}} x_{i,j}^p + \sum_{j \in \mathcal{V} \setminus \{0\}} x_{j,i}^p = 2 \times y_i^p \quad \forall i \in \mathcal{V}, \forall p \in \mathcal{H} \setminus \{0\} \quad (7) \\
& \sum_{i \in \mathcal{S}} \sum_{j \in \mathcal{S}, i < j} x_{i,j}^p \leq |\mathcal{S}| - 1 \quad \forall \mathcal{S} \subseteq \mathcal{V} \setminus \{0\}, p \in \mathcal{H} \setminus \{0\} \quad (8) \\
& x_{i,j}^p \in \{0, 1\} \quad \forall i, j \in \mathcal{V}, \forall p \in \mathcal{H} \setminus \{0\} \quad (9) \\
& y_i^p \in \{0, 1\} \quad \forall i \in \mathcal{V}, \forall p \in \mathcal{H} \setminus \{0\} \quad (10) \\
& q_i^p \geq 0 \quad \forall i \in \mathcal{V} \setminus \{0\}, \forall p \in \mathcal{H} \setminus \{0\} \quad (11) \\
& I_i^p \geq 0 \quad \forall i \in \mathcal{V}, \forall p \in \mathcal{H} \setminus \{0\} \quad (12)
\end{aligned}$$

---

The objective computes the total holding cost and the total traveling cost for the whole time horizon  $\mathcal{H}$ .

Constraints (1) are flow conservation constraints that compute the inventory level of the supplier at each period  $p \in \mathcal{H} \setminus \{0\}$  from its previous inventory level, the quantity produced and the quantities sent to the clients at period  $p$ . Similarly, Constraints (2) state the flow conservation constraints regarding the clients. They compute the inventory level of each client  $i \in \mathcal{V} \setminus \{0\}$  for each period  $p \in \mathcal{H} \setminus \{0\}$  from its previous inventory level, the quantity received from the supplier and its demand for period  $p$ .

The inventory capacity is enforced through several constraints: Constraints (3) state that the inventory level of client  $i \in \mathcal{V} \setminus \{0\}$  at any period  $p \in \mathcal{H}$  must be lower than  $I_i^{\max}$ , and Constraints (4) state that a replenishment of this client at period  $p \in \mathcal{H} \setminus \{0\}$  cannot exceed its maximal inventory level.

Constraints (5) link variables  $y_i^p$  with  $q_i^p$ , stating that a client  $i \in \mathcal{V} \setminus \{0\}$  which receives a quantity at period  $p \in \mathcal{H} \setminus \{0\}$ , is necessarily visited at period  $p$ .  $I_i^{\max}$  is used here as an upper bound for  $q_i^p$ . Constraints (6) work similarly for the supplier, stating that the quantity leaving supplier 0 at period  $p \in \mathcal{H} \setminus \{0\}$  is limited by the vehicle capacity  $C$ .

Constraints (7) state that if a location is visited, it is entered and left once. Constraints (8) eliminate sub-tours. Finally, constraints (9) to (12) enforce integrality and non-negativity conditions on the variables.

### 1.1.2 An illustrative example

Let us consider a small instance of the IRP where  $\mathcal{V} = \{0, 1, 2, \dots, 5\}$  is composed of five clients besides supplier 0, time horizon  $|\mathcal{H}| = 3$  and vehicle capacity  $C = 150$ . Table 1.1 lists all data related to the instance. The columns represent, respectively, the indices  $i$  of the supplier/clients, the coordinates  $(x_i; y_i)$ , the initial inventory  $I_i^0$ , the maximum inventory  $I_i^{\max}$ , the quantity  $R^p$  available to supplier 0 at each time period of horizon  $\mathcal{H}$ , the demand  $D_i^p$  of clients  $\{1, 2, \dots, 5\}$  for each time period of horizon  $\mathcal{H}$ , and finally the holding costs. The length of each edge approximates the cost of travelling the edge. This Euclidean distance is computed from the coordinates of the locations.

$i$	$(x_i; y_i)$	$I_i^0$	$I_i^{\max}$	$R^p$			$D_i^p$			$h_i$
				$p = 1$	$p = 2$	$p = 3$	$p = 1$	$p = 2$	$p = 3$	
0	(154;417)	510	$+\infty$	193	193	193				0.03
1	(172;334)	40	130				65	65	65	0.02
2	(267;87)	20	70				35	35	35	0.03
3	(148;433)	58	116				58	58	58	0.03
4	(355;444)	24	48				24	24	24	0.02
5	(38;152)	11	22				11	11	11	0.02

Table 1.1 – A representation of the data of the example instance

Table 1.2 and Figure 1.2 present an optimal solution for the example instance. Table 1.2 presents the inventory levels at the end of each period of each location and the quantities sent from the supplier to each client for the whole time horizon, and Figure 1.2 gives a graph-

ical overview of the same solution. In period  $p = 1$ , deliveries are made to clients 1, 2 and 5 in this order. For  $p = 2$ , the supplier replenishes clients 1, 3 and 4. Finally, for period  $p = 3$ , clients 1, 2, 3 and 5 are re-visited.

Note that in [Table 1.2](#) the inventory level is given at the end of the period, whereas [Figure 1.2](#) shows it at the beginning of the period. This choice was made to improve the figure readability; the inventory level at the end of the period in [Figure 1.2](#) can be computed by adding the quantity received to the inventory level at the beginning of the period, minus the demand of the client for that period.

$i$	$I_i^p$			$q_i^p$		
	$p = 1$	$p = 2$	$p = 3$	$p = 1$	$p = 2$	$p = 3$
0	553	596	639			
1	64	43	24	89	44	46
2	35	0	0	50	0	35
3	0	0	0	0	58	58
4	0	24	0	0	48	0
5	11	0	0	11	0	11

Table 1.2 – A solution for the example instance

### 1.1.3 Solving method

The mathematical formulation presented in [Section 1.1.1](#) is strengthened with additional valid inequalities presented in Archetti et al. (2007), Coelho et al. (2014b) and Desaulniers et al. (2016). Archetti’s valid inequalities are “logical inequalities” and are inspired by logical cuts introduced for problems such as the Orienteering Problem and the Undirected Selective Travelling Salesman Problem (TSP). Coelho’s valid inequalities determine the minimum number of routes in the planning horizon, whereas Desaulniers’s valid inequalities determine “the minimum number of sub-deliveries per demand”. Moreover, the bounds are improved and the routing component of the IRP reformulated according to the work of Lefever (2018b). Finally, sub-tour elimination constraints are added dynamically into the procedure as described in [Algorithm 1.1](#).

## 1.2 UNCERTAINTY IN THE IRP LITERATURE

A common challenge faced by all supply chain operations, the IRP included, is the management of uncertainties. Due to the multiplicity

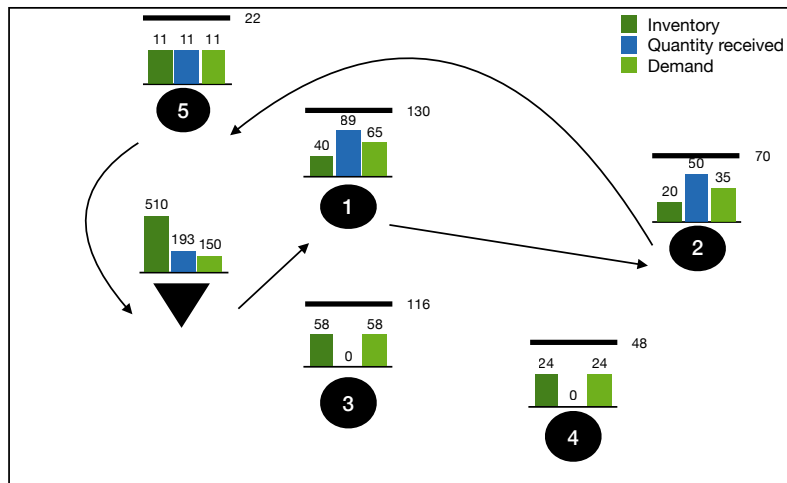

(a)  $p = 1$

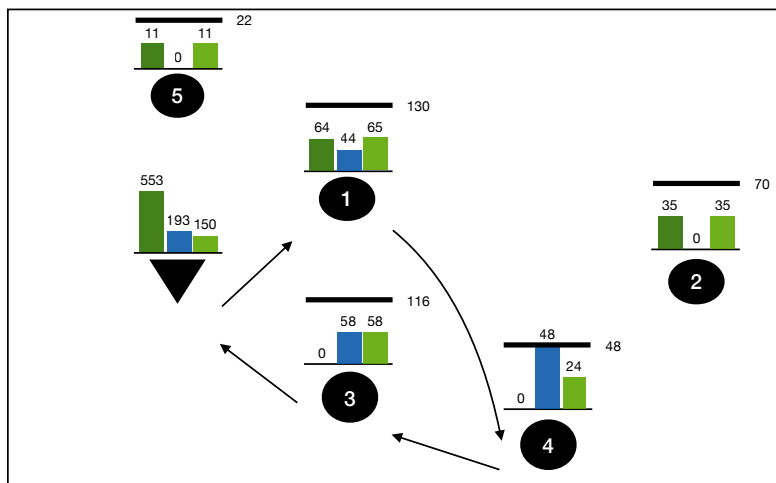

(b)  $p = 2$

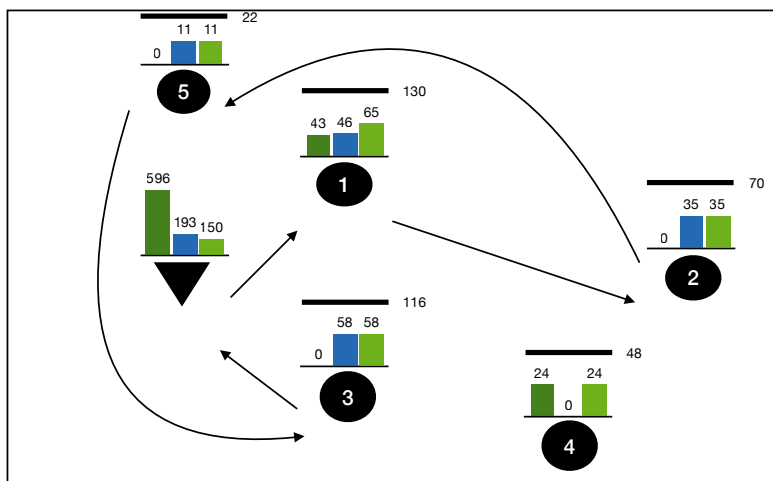

(c)  $p = 3$

Figure 1.2 – A solution for the example instance



---

**Algorithm 1.1:** Branch-and-cut procedure

---

```
1: input: an empty set of nodes  $\mathcal{Q}$  and an empty solution  $\mathcal{S}$ 
2: add the root node to  $\mathcal{Q}$  and set the upper bound  $\bar{b} = +\infty$ 
3: while  $\mathcal{Q}$  is not empty do
4:   solve the linear relaxation of the first node
5:   if the solution of the linear relaxation is fractional then
6:     Branch on fractional variables using the branching strategy
       in Lefever (2018b)
7:     Add the resulting nodes to  $\mathcal{Q}$  and delete the first node
8:   else
9:     if subtours  $\mathcal{S}$  exist then
10:      Add corresponding constraints (8)
11:    else
12:      if the objective value is smaller than  $\bar{b}$ , update  $\mathcal{S}$  to the
        solution and  $\bar{b}$  to the objective value.
13:      delete the node from  $\mathcal{Q}$ 
14:    end if
15:  end if
16: end while
17: return solution  $\mathcal{S}$ 
```

---

of actors and parameters of the IRP, the sources of uncertainties can be very large: “within combined inventory management and routing there are technical uncertainties due to transportation conditions and equipment, as well as economical or market uncertainties...” (Andersson et al., 2010). Moreover, uncertainties can be handled in different manners: in an *a priori* or in an *a posteriori* fashion.

Using the keywords *uncertainty*, *stochastic*, *re-optimisation*, *robust* combined to *inventory routing problem*, *VMI*, we identified 46 articles dealing with uncertainty in IRP. In the following, the main sources of uncertainties for the IRP encountered in the literature are listed. Moreover, the identified references are classified with respect to the sources of uncertainties handled and the approaches used in Table 1.3 and Table 1.4.

### 1.2.1 Sources of uncertainty

Figure 1.3 summarises the sources of uncertainties treated in the literature related to the different parameters of the IRP, presented in Figure 1.1. These uncertainties are detailed in next sections.

#### 1.2.1.1 Uncertainties related to the clients

**DEMAND VARIATION.** The demand of the client can change : this source of uncertainty is considered in a vast majority of the articles reviewed, namely 38 out of 46 articles. It is also the case

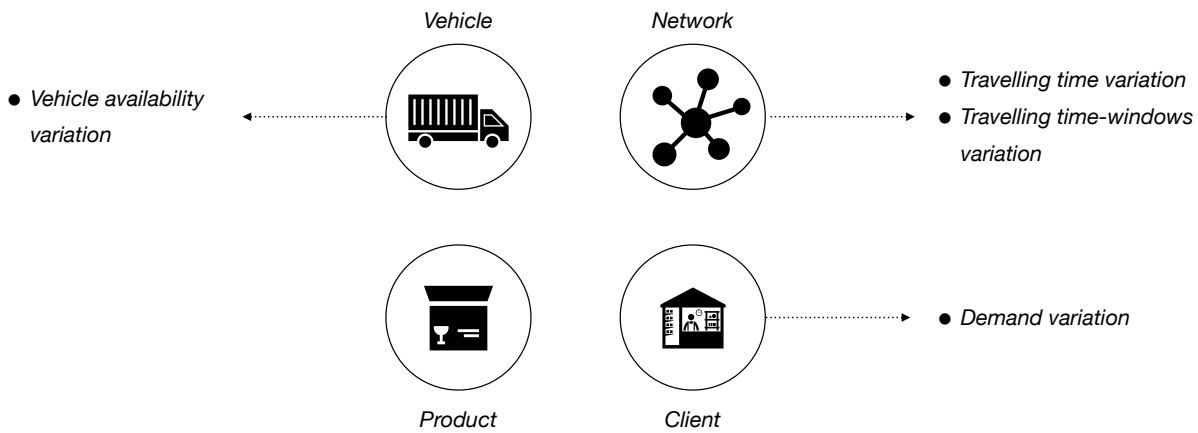

Figure 1.3 – A summary of the different sources of uncertainties treated in the IRP literature

in this dissertation since it can have an impact in both inventory and routing decisions.

#### 1.2.1.2 *Uncertainties related to the vehicles*

**VEHICLE AVAILABILITY VARIATION.** A dysfunction of one of the vehicles of the fleet or the unavailability of one of the drivers can occur. Only Jafarian et al. (2019) and Dong et al. (2018) address this source of uncertainty.

#### 1.2.1.3 *Uncertainties related to the network*

**SUPPLIER QUANTITY VARIATION.** The quantity available at the supplier at the beginning of each period can change. Only Dong et al. (2018) address this uncertainty.

**TRAVELLING TIME VARIATIONS.** Since routing is a part of the IRP, all the disruptions faced in urban delivery are possible, especially traffic jams or time-dependant travelling times where the travelling time depends on the departure time. 11 articles take interest of this source of uncertainty. It is the case of this dissertation as well, as it is a source of uncertainty that can be faced in all variants of the IRP and can have an impact on inventory management decisions.

**TRAVELLING TIME WINDOWS VARIATIONS.** Weather conditions can result in a disruption of the travelling time windows, especially when delivering liquid gases, since the high temperature can build-up the pressure of the gas (Cho et al., 2018) and/or in the context of maritime IRP, where unperturbed weather condi-

tions are necessary for the safety of the trip. 5 articles tackle this uncertainty in the context of maritime IRP.

### 1.2.2 Approaches to handle uncertainty

Two different ways to handle uncertainties can be distinguished. On the one hand, *a priori* methods anticipate uncertainties by building solutions that are able to resist potential disruptions. Stochastic optimisation and robust optimisation are the most commonly used *a priori* methods in the literature. Stochastic optimisation is generally considered when a probabilistic distribution of the uncertainty is known: the objective is then to optimise the expected value of a chosen criterion. A review of the different stochastic optimisation methods used in the literature of the IRP under demand and lead times uncertainty is presented in Roldán et al. (2017). In robust optimisation, the uncertainties are presented as a set of scenarios, and solutions generated should be able to resist all or some of these scenarios. *A posteriori* methods, on the other hand, react to the unexpected events after they occur. This can be done either through local repair, or by a complete re-optimisation of a deterministic model once the disruptions are revealed.

Table 1.3 and Table 1.4 show a huge disparity in the approaches used to handle uncertainty in the IRP literature. Over the 46 identified references, 45 handle the uncertainty in an *a priori* fashion. However, although re-optimisation has been used for the IRP in a deterministic rolling horizon context (Al-Ameri et al., 2008; Rakke et al., 2011), only Dong et al. (2018) use it to cater for uncertainty issues.

In Al-Ameri et al. (2008) and Rakke et al. (2011), the rolling horizon decomposition is used as a matheuristic in order to solve large-sized instances. The time horizon of the IRP is decomposed into smaller periods of time, the first of which is solved to optimality while the others are relaxed. Then, iteratively, the variables of the already solved periods are fixed and the next one is solved to optimality, relaxing the remaining ones. For Dong et al. (2018) the process is slightly different. The first iteration solves the IRP under stochastic parameters using a stochastic MIP over the whole horizon. Then, for each period of the horizon, new information is revealed. If the solution of the stochastic problem is infeasible given the new information, a full re-optimisation is conducted over the whole horizon, modelling the new information as deterministic parameters while keeping the others stochastic. Once the re-optimised solution is obtained, the horizon is rolled by fixing the variables related to the first periods of the re-optimised solution. The procedure is then iterated until the end of the horizon.

	Uncertainties				Optimisation methods			
	Demand	Travelling time	Travelling time windows	Vehicle availability	Supplier quantity	Stochastic optimisation	Robust optimisation	Re-optimisation
Trudeau et al. (1992)	✓					✓		
Nori et al. (2002)	✓					✓		
Kleywegt et al. (2004)	✓					✓		
Christiansen et al. (2005)	✓						✓	
Aghezzaf (2008)	✓	✓					✓	
Hvattum et al. (2009)	✓					✓		
Chen et al. (2009)	✓					✓		
Huang et al. (2010)	✓					✓		
Yu et al. (2012)	✓					✓		
Solyah et al. (2012)	✓						✓	
Karoonsoontawong et al. (2013)	✓					✓		
Rahim et al. (2014)	✓					✓		
Juan et al. (2014)	✓					✓		
Nolz et al. (2014)	✓					✓	✓	
Bertazzi et al. (2015)	✓					✓		
Niakan et al. (2015)	✓	✓				✓		
Agra et al. (2015)	✓	✓		✓		✓		
Malekly (2015)	✓	✓				✓		
Zhang et al. (2015)		✓					✓	
Soysal et al. (2015)	✓					✓		
Soysal (2016)	✓					✓		
Chow (2016)	✓					✓		
Bertsimas et al. (2016)	✓						✓	

	Uncertainties				Optimisation methods			
	Demand	Travelling time	Travelling time windows	Vehicle availability	Supplier quantity	Stochastic optimisation	Robust optimisation	Re-optimisation
Yang et al. (2016)	✓						✓	
Li et al. (2016b)	✓					✓		
Li et al. (2016a)	✓						✓	
Ercan et al. (2017)	✓					✓		
Kazemi et al. (2017)	✓						✓	
Rahbari et al. (2017)	✓	✓					✓	
Rahimi et al. (2017)	✓	✓				✓		
Agra et al. (2018)			✓				✓	
Cho et al. (2018)			✓			✓		
Hu et al. (2018)	✓					✓		
Micheli et al. (2018)	✓					✓		
Gruher et al. (2018)	✓					✓		
Ghasemi et al. (2018)	✓					✓		
Soysal et al. (2018)	✓					✓		
Lefever (2018a)		✓				✓	✓	
Dong et al. (2018)	✓	✓	✓	✓	✓	✓		✓
Jafarian et al. (2019)				✓		✓		
Nikzad et al. (2019)	✓					✓		
Rodrigues et al. (2019)		✓				✓	✓	
Fardi et al. (2019)	✓						✓	
Diz et al. (2019)			✓				✓	
Mirzapour Al-e-hashem et al. (2019)	✓					✓		
Lefever et al. (2021)		✓					✓	

Table 1.4 – IRP under uncertainty literature overview part 2/2

### 1.3 DISSERTATION OBJECTIVES

The objective of this dissertation is to break the tendency to mostly manage uncertainties in an *a priori* fashion with stochastic and robust optimisation approaches. The main drawback of such approaches is usually the cost of protection. As an illustration, note that the most common robust approach makes plans that resist to the worst case scenario. In the IRP, if the clients' demand is uncertain, the worst case scenario uses the upper bound of the demand variability interval, therefore the solution includes large safety stocks. If the demand turns out to be smaller than the worst case (and it is bound to be in the vast majority of cases), the inventory will turn out to be oversized, which makes the robust solution very costly. Another example of a worst case scenario would be to consider the maximal possible travelling time, when travelling times are uncertain. In this case, if the driver does not in fact face any problem when travelling from a client to another, he will arrive earlier than planned and in this case will have to stay idle for some time in order to visit the client on schedule. This shows the problem with robust approaches: in trying to resist all possible uncertainties, the yielded solutions are highly conservative, which makes them expensive, especially when the range of variability of the uncertain parameter is wide.

In this dissertation, we focus on the most commonly faced sources of uncertainty in real-life situations: the clients' demand and the travelling time.

#### 1.3.1 Demand uncertainty

In real-life situations, clients rarely place an order by giving a probabilistic distribution or an interval. Instead, they compute a value based on historical data, and this value is subject to modification at any moment in the time-horizon. Therefore, the most natural way to handle such uncertainty is to wait for it to be revealed and repair the initial plans accordingly or conduct a full re-optimisation.

As seen in [Table 1.3](#) and [Table 1.4](#), the literature of the IRP where uncertainties are handled through re-optimisation is rather sparse. This gap might be explained by the fact that re-optimisation can be ill-suited to routing problems. In the case of the Vehicle Routing Problem (VRP), Salavati-Khoshghalb et al. (2019) state that from a cost perspective, re-optimising routing decisions once uncertainties are revealed is a better theoretical alternative to *a priori* approaches. Although, solving a VRP with re-optimisation is challenging. Moreover, *a priori* approaches tend to preserve consistency in routing operations which is not the case for re-optimisation. However, although routing is an important component of the IRP, its other components provide adjustment variables that are not available in the VRP, such

as its multi-period dimension, the availability of an inventory, or possible transshipment. Indeed, the possibility to anticipate a delivery, as well as the buffer provided by inventories at both the supplier and its client give extra flexibility to react to uncertainties. Therefore, we believe *a posteriori* approaches for the IRP should be investigated.

One *a posteriori* strategy is to repair the initial solution by making small modifications to turn the solution into a feasible one. For example, if the demand of a client  $i$  increases on Tuesday when no supply was planned for him, and his inventory level is not sufficient to cover the demand increase, he will need an extra visit in the repaired solution. If the vehicles used for this period are already at full capacity in the initial solution, the decision-maker should decide whether to replace a client  $j$  in the routing with client  $i$  or using another vehicle to make a direct replenishment for client  $i$ . The difficulty here is the trade-off between the feasibility of the solutions and its cost-efficiency; and when more clients' demands change, the set of possibilities increases exponentially, making repair strategies hard to develop. Another approach is a full re-optimisation of the initial solution, from the time the unexpected event is revealed until the end of the time horizon. The drawback of this approach is that the new solution can be completely different from the initial one. This creates organisational issues: for example, if the new plan requires more vehicles, and therefore more drivers, they might be difficult to find at short notice – also, if the supplier keeps changing his delivery date, the client can lose trust and look for a different supplier. Such situations lead to additional costs that are very difficult to quantify: the decision maker may therefore favour “stable” solutions when re-optimising.

But how to know a solution is stable? Herroelen et al. (2005) define a stable plan as one that “*deviates as little as possible from the original one*”. This definition being very general, its application in the case of IRP is not straightforward. For example, let us consider a plan which replenishes five clients in a certain sequence on a given day; two solutions are proposed to deal with a demand increase from one client. The first solution keeps the same set of clients in the same sequence but replenishes them with quantities that differ from the initial solution. Another solution removes one client from the route and changes the sequence. Which of these solutions provides the smallest deviation, thus is the most stable? There is no straightforward answer.

This leads to our first research question:

*How to measure stability in the IRP under demand uncertainty?*

We focus on demand uncertainty; this uncertainty is handled in an *a posteriori* approach, through re-optimisation. For this approach to make sense from a practical point of view, it is necessary to define

metrics that can adequately quantify stability for the IRP. Since the actors and parameters of the IRP are multiple, a single stability metric can only cover a part of the full range of stability. Therefore, ensuring overall stability requires a careful choice of metrics. The correlation of the stability metrics should thus be studied in relation to each other, and to the initial objective – namely, the cost.

### 1.3.2 *Travelling time uncertainty*

When it comes to time uncertainty, an *a priori* approach seems appropriate, since a time interval can be a good representation for the time required to travel from one location to another. The most common example is a quick search on any GPS navigation software. However, unlike the demand, the source of time volatility is not unpredictable but depends on deterministic parameters.

We can distinguish two different types of time in routing problems such as the IRP: travelling time and service time. For the service time, it can be decomposed into two types as well: parking/administrative operations times and unloading times. For the travelling time, the volatility is generally due to the fact that the IRPs evolve in an urban logistic context, where traffic conditions can vary throughout the day. This volatility is not random but rather time dependent. It means that the travelling time does not depend only on the departure and arrival locations, but depends on the time of departure as well. The same thing can be said for parking times, as looking for a parking spot in rush hours can take longer than at other hours of the day. For unloading times, they are not time dependent, but rather quantity dependent. It means that unloading one unit of product does not take as much as time as unloading a dozen of units.

In this dissertation, we focus only on travelling time uncertainties by handling them in an *a priori* but deterministic fashion, by considering them as time dependent. However, time dependent routing problems tend to be more difficult to solve than their basic counterpart (Gendreau et al., 2015). This leads to our second research question:

*How to incorporate the time dependent aspect in the IRP and solve it efficiently?*

To this purpose, mathematical formulations are proposed and compared, a new benchmark presented and a matheuristic developed.



### 1.3.3 Structure of the dissertation

Figure 1.4 summarises the structure of the dissertation.

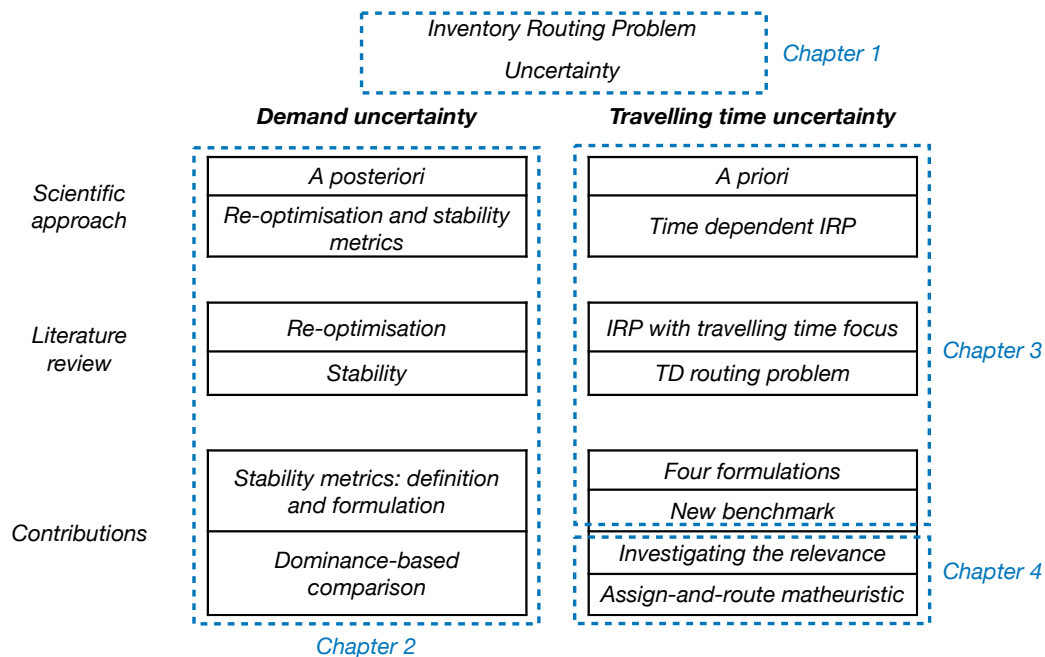

Figure 1.4 – A summary of the dissertation structure

**Chapter 2** is dedicated to answering the first research question. A review of the literature of re-optimisation approaches for NP-Hard problems, in general, and sequencing problems such as scheduling and routing problems, in particular, is conducted. The literature shows that re-optimisation problems are generally as hard as the initial ones, thus their respective optimal solutions may be completely different. Therefore, stability metrics in sub-problems of the IRP such as routing and inventory management and similar sequencing problems such as scheduling are reviewed. A subset of these metrics is designated to be re-adapted for the IRP. The re-optimisation problem in relation to the initial objective, i.e. the total cost (composed of holding and transportation costs), is formulated. The stability metrics are re-adapted and their advantages and drawbacks discussed. Some of these metrics are mathematically formulated and their correlation and their impact in relation to the cost investigated.

**Chapter 3** and **Chapter 4** answer the second question of this dissertation. In **Chapter 3**, a review of the literature of IRP variants where the travelling time is the main focus is proposed. The review shows that the the time dependent IRP (TD-IRP) literature is rather sparse. Thus, the focus of the review shifts to pure time dependent routing problems. Based on the riche literature of time dependent routing problems, four mathematical formulations for the TD-IRP are pro-

posed and a new benchmark, based on benchmarks of the IRP and TD-TSP literature, is generated. Moreover, numerical experiments are conducted to compare the performances of the four formulations. In [Chapter 4](#), the relevance of considering the travelling time as time dependent regarding the gain in the solutions' cost and the computational complexity is investigated through numerical experiments. Inspired by the results, a matheuristic is proposed to solve large-sized instances.

The summary of contributions and short-term perspectives are given at the end of each chapter. The final summary of contributions and mid and long-term perspectives are presented in [Chapter 5](#).



The uncertainty of the clients' demand is one of the most commonly treated uncertainty in the IRP literature. However, most scholars tackle this problem through *a priori* approaches, such as stochastic and robust optimisation. In this chapter, a re-optimisation approach is proposed. As re-optimisation problems tend to be as hard as the initial problems, optimal re-optimisation solutions may be completely different than the initial ones, thus creating organisational issues. The objective of this chapter is to answer the first question of our dissertation "*how to measure stability in the IRP under demand uncertainty?*". In order to control the difference between the initial and the re-optimisation, stability metrics are proposed and compared.

This chapter is organised as follows: [Section 2.1.1](#) review the literature of re-optimisation as an approach to handle uncertainty in different fields such as routing problems, scheduling and graph theory. However, since such studies do not take into consideration stability as a re-optimisation criterion, we look for stability metrics in different fields of the literature, but close enough that these metrics could be adapted to our problem. [Section 2.1.2](#) thus reviews stability applied to the Travelling Salesman Problem, Vehicle Routing Problem, Inventory Management and Scheduling, to look for stability metrics that may be adapted to fit our needs. In [Section 2.2](#), a cost-based re-optimisation model is proposed. The approach is illustrated through the example presented [Section 1.1.2](#) when faced with unexpected events, without stability concerns at this point. In [Section 2.3](#), seven stability metrics are identified from the conducted literature review; the advantages and drawbacks of adapting these measures to the IRP are discussed, and a mathematical formulation adapted to the IRP is proposed for the most relevant metrics. Numerical experiments are performed in [Section 2.4](#) to test the proposed mathematical formulations and investigate the correlations between the stability metrics proposed and their correlation to the initial objective, the cost.

## 2.1 LITERATURE REVIEW

The literature of re-optimisation as an approach to cater for uncertainty issues focuses on two aspects: First, the complexity of the re-optimisation problems as well as their solving approaches. Second, controlling the deviation between the initial solution and the re-optimised one.

### 2.1.1.1 *Solving re-optimisation problems*

Re-optimisation is an up-and-coming optimisation field that tries to cater for uncertainty problems. Considering a problem with an optimal solution, the purpose behind re-optimisation is to find an optimal solution for a new perturbed instance. Boria et al. (2011) present an overview of works related to the field.

The first scholars to tackle dynamic or uncertain problems by using re-optimisation are Frederickson (1985), Rohnert (1985), and Der-touzou et al. (1989). In this case, polynomial problems such as minimum spanning-tree or shortest path are targeted. The objective is to maintain the optimality of the solutions when the departure or arrival vertex is modified for the shortest path, or there is an insertion, a deletion or a modification of the weight of an edge for both problems. However, it is only until the early years of the 21<sup>st</sup> century that this two-stage re-optimisation (i.e. initial and perturbed state) emerged. This new paradigm is applied in many research projects and for various fields. In the following, we focus on NP-Hard problems in general, and sequencing problems such as scheduling and routing problems which are a component of the IRP, in particular.

#### 2.1.1.1.1 *Graph problems*

In graph theory, there is a variety of NP-Hard problems such as the max-independent set, max k-colorable, max split graph, Steiner tree... Many scholars tackled the re-optimisation of these problems under the addition or the removal of a vertex from the graph or the modification of the weight of an edge. Scholars show that the re-optimisation problems are just as hard as the initial problems. To that purpose, the authors of Bilò et al. (2008) improve approximation ratios of different approximation algorithms for finding the minimum Steiner tree when the weight of an edge in the original instance is modified. Böckenhauer et al. (2009) presents a proof that the re-optimisation of the steiner tree is just as hard as the original when a vertex is added or removed. Moreover, the authors propose a new approximation algorithm improving the best approximation ratio known. Boria et al. (2013) focus on improving the approximation ratios of the max independent set, max k-colorable sub-graph and max split sub-graph, when vertices are added or removed.

#### 2.1.1.1.2 *Scheduling problems*

In scheduling, the literature of re-optimisation problems is quite rich. And similarly to graph problems, scholars show that such

problems are as hard as the initial ones and focus on efficient approaches to solve them. Zweben et al. (1993) present an approach called “Gerry” that uses constraint-based iterative repair as well as simulated annealing notions. It is used in the context of space shuttle ground processing which encompasses the scheduling of inspection and repair tasks of space shuttles in preparation for launch. Fang et al. (1993) solve the job-shop rescheduling problem where the processing time or the starting time of a task may be modified. Using a recursive approach, a set of tasks that are impacted by the change are designated and a smaller job-shop scheduling problem is solved by a GA (Genetic Algorithm). Schäffter (1997) tackles the problem of re-scheduling with forbidden sets i.e. sets of tasks that are not allowed to be scheduled in parallel. The author proves that the problem is as hard as the original problem. Furthermore, approximation algorithms with ratios of  $3/2$  and  $4/3$ , for the cases where, respectively, one forbidden set or more is added, or removed, are presented. Boria et al. (2014) tackle the re-optimisation of various NP-hard min-sum scheduling problems. The approximation ratios of simple re-optimisation strategies, under job insertion or deletion, are analysed. Fang et al. (2015) present a survey for re-scheduling in railway networks where the various models are categorised in respect to their constraints and objectives. Also, solution approaches are presented, and their advantages and inconveniences discussed.

### 2.1.1.3 Routing problems

Just as scheduling problems, re-optimisation for routing problems is the focus of numerous scholars. The literature is mostly focused on the well known routing problems: the shortest path, TSP, VRP. Desrochers et al. (1988) tackle the problem of the shortest path problem with time windows. They prove that the re-optimisation problem is as hard as the original one and present a primal-dual algorithm with a pseudo-polynomial complexity to optimally solve it. Bertsimas (1992) solves the stochastic VRP with a worst-case *a priori* approach and compares it to two strategies of re-optimisation i.e. in the case where, respectively, the demand is known at the moment of the visit of a customer and/or at the start of the tour. Haughton (2000) introduces a framework to quantify the benefits of re-optimisation for the stochastic VRP considering, among others, the service region and the capacity of the fleet. Archetti et al. (2003) tackle the TSP for cases when one node is added or removed. This work concludes that the re-optimisation problem is as hard as the original problem. The study also shows that the application of the cheapest insertion heuristic (Rosenkrants et al., 1977), in the case where a node is added, reduces the best known approximation ratio. Böckenhauer et al. (2007) prove that although the TSP when the weight of an edge is modi-

fied is as hard as the original one, it admits a better approximation algorithm than when a vertex is added or removed, and present a new algorithms that improves the approximation ratio. Ausiello et al. (2009) propose an approximation algorithm for the Min-TSP when a vertex is added. The authors show that in case of the Max-TSP, a simple heuristic is asymptotically optimum when a constant number of nodes are inserted and propose an approximation algorithm for the general case. Secomandi et al. (2009) solve the vehicle routing problem with stochastic demand by modelling it as a finite-horizon markovian decision process. Optimality is achieved for instances up to 15 customers. For larger instances, they propose a partial re-optimisation process where only a subset of the markovian decision process states is taken into consideration. Two heuristics to determine these states are presented, respectively, the partitioning heuristic and the sliding heuristic . Delage et al. (2010) propose dynamic programming and tabu-search approaches to re-optimize the multi-depot vehicle routing problem with time windows when the service time is uncertain. Böckenhauer et al. (2010) tackle the TSP with deadlines where a vertex must be visited before a certain deadline. The modification in this context is consist of the addition or the deletion of a vertex as well as of a deadline. An approximation algorithm is proposed to solve the problem. Chow (2014) proposes two re-optimisation algorithms to solve the generalised selective household activity routing problem: An adapted version of the 2-opt heuristic for tours improvement and the first meta-heuristic designed for re-optimisation called Genetic Algorithm with Mitochondrial Eve. Spliet et al. (2014) propose a mathematical model and a two-phased heuristic for the capacitated vehicle routing problem, where a deviation of the original schedule results in an additional cost. The cost in this case depends on the vertex itself as well as its position in the sequence. Monnot (2015) achieves the same approximation ratio as Ausiello et al. (2009) for the TSP but improves the complexity of the algorithm to a linear one. Ulmer (2019) introduces the notion of degree of dynamism (DOD) and tries to identify the most suitable approach for a dynamic vehicle routing problem (i.e. re-optimisation or anticipation) in respect to its DOD. The study concludes that for low DODs, re-optimisation can be a very good tool, whereas for higher ones, anticipation is needed.

Intuitively, when considering re-optimisation approaches, we estimate that the initial solution can be a good starting point in order to obtain optimality for the disrupted problem. However, as shown in the literature presented above, re-optimisation problems are in most cases as hard as the initial problem. This means two things: First, since the complexity of the IRP can be reduced to most of the problems cited, re-optimisation for the IRP is NP-hard as well. Thus, it is necessary to propose exact approaches to obtain optimal re-optimised

solutions. Second, as there is no obvious path to transform the optimal solution of the initial problem into an optimal solution of the re-optimisation problem, the two solutions may be completely different.

### 2.1.2 *Stability as a re-optimisation criterion*

As stated in Salavati-Khoshghalb et al. (2019), when considering re-optimisation to handle uncertainty problems, one of the main problems that can be faced is the instability, sometimes called “nervousness”, of the new re-optimised plans with regards to the initial ones.

The definition of stability in re-optimisation problems has been tackled for different fields, but not for the IRP, as shown in Section 1.2. However, since the problem under consideration is an integration of two sub-problems, respectively, inventory management and routing, we can look at the definition of stability in these component problems. The following sections present the related works dedicated to stability in these two fields, in addition to scheduling problems, which are commonly used as reductions for routing problems. Within these fields, a special care is given to problems modelled over a rolling horizon: while they do not carry out re-optimisation as such, they often deal with uncertainty with a real concern for stability.

The lack of an agreed-upon definition of stability or a well-established vocabulary regarding the issue at hand makes it difficult to list keywords that ensure an exhaustive search. We used the keywords “stability”, “nervousness” and “disruption management”; a screening was then conducted among those results, to keep only the relevant articles concerning stability as a re-optimisation criterion.

#### 2.1.2.1 *Stability concerns in scheduling*

Stability when re-optimising was first tackled in the scheduling field by Wu et al. (1993). In this work, heuristics are proposed to re-schedule jobs on one machine when a disruption occurs, e.g. a machine failure, with two objectives: efficiency (i.e. makespan) and stability. Two strategies are conducted: first, a full re-optimisation of the unfinished tasks before the disruption. Second, a “right-shift” strategy, where the exact sequence that was to be performed in the original schedule is performed after the disruption, absorbing the idle times if possible in the process. In this context, a stable schedule is one that minimises the sum of the absolute difference of starting times for all tasks as well as preserving the sequence between the re-optimised and the original schedule. Since the right shift strategy gives by definition more stable solutions, the focus of Wu et al. (1993) is to present local search-based heuristics for the re-optimisation process to keep the solution stable.



Several articles extend the work done by Wu et al. (1993). Cowling et al. (2002) present a bi-objective study that takes utility and stability as optimisation criteria. The utility is defined as the deviation in completion time between the original schedule and the re-optimised one. Stability takes into account, in addition to the deviation of the starting time, the deviation of the completion time of each task separately. This is because the disruption in this case is not only a machine dysfunction, but can be, among others, a change in the processing time as well. Rangsaritratsamee et al. (2004) present a dynamic job shop rescheduling. The rescheduling policy is called “discrete event driven rescheduling” and is the result of a work presented in Church et al. (1992) in the context of rescheduling production systems under dynamic job arrivals. A scheduling horizon is defined, and “rescheduling points” designated on it. At each rescheduling point, the jobs to be scheduled are the ones that are not scheduled at the previous rescheduling point or the ones that arrived afterwards. The multi-objective efficiency/stability is reconsidered, while adding, in addition to the starting time deviation, a new stability metric, inspired by the work of Lin et al. (1994) and called “the total deviation penalty”. It associates a penalty, restrictively, to jobs rescheduled earlier: the earlier the job is rescheduled, the bigger the penalty. In this context, a genetic algorithm is presented to generate schedules at each rescheduling point.

Curry et al. (2005) present a simulation study that investigates the trade-off between two conflicting objectives, respectively, a step-wise increasing tardiness cost function and a metric of stability, defined by the proportion of rescheduled jobs that change machine assignment during rescheduling. A branch-and-price algorithm is presented in this case to solve the re-scheduling problem.

Pfeiffer et al. (2007) present a simulation-based stability evaluation of different rescheduling policies, such as: right-shift schedule, complete re-scheduling... Both single and multi-machine job-shop problems are investigated and an industrial application is presented. In this case, the stability metrics considered are the ones presented in Rangsaritratsamee et al. (2004), i.e. starting time deviation and total deviation penalty. However, no hint is given about which strategy performs better in terms of stability.

The machine re-assignment and starting time deviations metrics will be discussed for the IRP in [Section 2.3](#).

#### 2.1.2.2 *Stability concerns in routing*

Sörensen (2006) proposes a bi-objective approach to ensure the stability of the route in a vehicle routing problem. The stability of a route is assessed by the re-adaptation of the “edit distance” approach introduced by Levenshtein (1966). The idea behind this approach is to minimise the number of steps to transform a string into another

string by a set of operators, respectively: addition, deletion and substitution. In the case of the VRP, the strings are the set of routes of the solution. The problem is solved as follows: first, dynamic programming is used to find the minimum operations to transform each route of the original solution to each route of the re-optimised one. Second, a mathematical assignment model computes the optimal edit distance between the original solution and the re-optimised one.

Schönberger et al. (2008) tackle the problem of “nervousness”, defined as “the symptom appearing during the transition from the so far followed schedule to an updated schedule after additional requests appeared”. Nervousness issues are classified into two types: external nervousness which affects the client (e.g. a change in the arrival time) and internal nervousness which does not matter for the client (e.g. a re-assignment to another vehicle – however, whether vehicle re-assignment is really external can be debated upon, since some clients prefer having the same driver when served). Then, an adaptive control of a subcontractor to balance the workload of a capacitated fleet of vehicle is proposed and investigated. Three metrics are used to assess the nervousness, two external and one internal. Mode Selection Nervousness represents the ratio of the clients visited with a different transport mode compared to the original schedule (i.e. a change from an owned vehicle to a subcontractor) ; Resource Assignment Nervousness represents the ratio of the clients that are re-assigned to a different vehicle. The internal metric, Arrival Time Nervousness, represents the ratio of clients for which the arrival time has been modified.

Zhang et al. (2007) and Wang et al. (2011) take interest in the VRP with time windows under uncertainty. Disruptions for Zhang et al. (2007) are the unavailability of a vehicle for an interval of time due to vehicle failure or traffic conditions. In Wang et al. (2011), possible disruptions are a modification of the delivery address of a client, a deviation in its time window, a perturbation of its demand, a deletion of a request or any combination of these disruptions. To ensure the stability of the re-optimised solution, both articles use a metric on customer service time where a penalty is applied if the client is served in a time that is outside of its time window. Wang et al. (2011) extend the stability metrics with two other criteria. First, a metric on driving paths where a penalty is applied if an arc that did not exist in the original solution appears in the re-optimised one and vice versa. Second, a metric on delivery costs is the deviation between the costs of the original and the re-optimised solution.

Dettenbach et al. (2015) present a mathematical model to re-optimize tours in last mile distribution with electric vehicles fleet. The network is in this case decomposed into multiple districts and all clients of one district are assigned to a vehicle. In case of a failure, which is presented as a dysfunction of one of the electric vehicles or the absence

of a driver, the model is supposed to select a back-up district whose clients are to be dispatched and added to the other districts. The stability is modelled as constraints. Each time a district is dispatched, it is decomposed into a certain number of paths, this number being smaller or equal to the number of operational vehicles, i.e. the number of non-dispatched districts. These paths are then inserted in other districts, in the place of one and only one edge, keeping the sequence the same as in the original route.

The sequence preservation, edit distance and mode selection nervousness metrics, in addition to resource re-assignment and arrival time deviation which are similar to, respectively, machine re-assignment and starting time deviation will be discussed for the IRP in [Section 2.3](#).

### 2.1.2.3 *Stability concerns in inventory management*

Uncertainty is a key component in inventory management. Usually, it is tackled using stochastic formulations and/or by sizing a safety stock, which are *a priori* methods. On the contrary, in the current work we investigate stability in re-optimisation, which is an *a posteriori* method.

Re-optimisation is not a field of work in inventory management, because the problem of when and how much to order when demand changes is rather easy : a typical example is Wilson's model (Harris, 1919) whose complexity is in  $O(1)$ .

Many scholars take interest on problems of inventory management by assessing the impact on the cost while comparing different replenishment strategies or when considering a bad evaluation of the holding cost, referring to it as a "robustness study". Inderfurth (1994) is the first to tackle the problem of "nervousness" in inventory management. In this paper, the nervousness in the context of a rolling planning horizon is shown to be heavily affected by the choice of the inventory policy. A comparison between the  $(s, S)$  and  $(s, nQ)$  policies is presented. The work concludes that the reorder point  $s$  plays a less important role than the size of the lot  $Q$ , which means that the superiority of the  $(s, S)$  policy, which can be shown to be optimal for a wide class of problems under pure cost consideration, needs to be reconsidered under stability criteria. In this context, a robust/stable solution is one that minimises the deviation in the solution cost.

However, what interests us is a solution that minimises the deviation in the solution structure, i.e. the order quantity and order frequency. This definition of stability is implicitly implied in well known replenishment strategies (such as fixed order quantity, economic order quantity, or order up-to-levels) that set replenishment at fixed intervals and/or in fixed quantity. Here the stability is ensured by the solution structure itself, i.e. the fact that we are looking for a fixed

interval and/or a fixed quantity. Therefore a stability metric does not seem necessary.

However, in the context of production planning with problems such as Lot Sizing, Master Production Schedule (MPS), Material Requirements Planning (MRP) or Capacity Expansion Planning (CEP), where the notion of inventory management is a key element, stability in the sense of solution structure has been of interest. The work in Sridharan et al. (1988) is the first to tackle the problem of quantifying stability under rolling horizon planning and is a basis for numerous future works. In this paper, stability is quantified by the difference between the quantity planned originally and the re-optimised quantity for the MPS. They propose to weight the metric in order to prioritise the stability of closer periods. This metric has been re-adapted to other problems (Herrera et al., 2016; Kadipasaoglu et al., 1997; Kimms, 1998; Narayanan et al., 2010; Sahin et al., 2008).

Kadipasaoglu et al. (1997) re-adapt the same metric for the MRP and propose a new one based on the deviation in frequency of replenishments. Kimms (1998) re-adapts the metric to CEP and Lot Sizing. Sahin et al. (2008) extend the work of Kadipasaoglu et al. (1997) and propose a new metric that quantifies the number of deviations in replenishments: a deviation occurs if a client is replenished at a period when it was not supposed to be in the initial plan, and vice versa. Narayanan et al. (2010) combine the metrics of Sridharan et al. (1988) and Sahin et al. (2008) for the joint replenishment lot sizing problem. They propose nine local-search based heuristics and investigate the trade-off between stability and the cost of the obtained solutions. Finally, Herrera et al. (2016) extend the work of Sridharan et al. (1988) for the MPS by proposing sub-metrics of stability that quantify the deviation of the quantity for each period and not only for the whole horizon. Their experiments show that an improvement in stability does not lead to a significant cost increase.

The replenishment deviation and quantity deviation metrics will be discussed for the IRP in [Section 2.3](#).

#### 2.1.2.4 *Literature review synthesis*

A summary of the conducted literature review of the stability metrics is presented in [Table 2.1](#). The rows of this table use the names of the stability metrics that we propose for the IRP and which will be presented in [Section 2.3](#), and link them to their counterpart in the literature review of the different fields – namely, scheduling, routing and inventory management. The names given in the table cells are those used by the authors, when they differ from the name we use. This shows the terminology appears to depend on the fields, although the metrics are quite similar: hence the need for us to propose names for the IRP metrics.

	Scheduling	Routing	Inventory management
Sequence preservation		Dettenbach et al. (2015) and Wang et al. (2011)	
Visit deviation			Replenishment deviation (Narayanan et al., 2010; Sahin et al., 2008)
Quantity deviation			Herrera et al. (2016), Kadi-pasaoglu et al. (1997), Kimms (1998), Narayanan et al. (2010), Sahin et al. (2008), and Sridharan et al. (1988)
Edit distance		Sørensen (2006)	
Client re-allocation	Machine re-assignment (Curry et al., 2005)	Resource re-assignment nervousness (Schönberger et al., 2008)	
Delivery system modification		Mode selection nervousness (Schönberger et al., 2008)	
Visiting time deviation	Starting time deviation (Cowling et al., 2002; Pfeiffer et al., 2007; Rangsaritratsamee et al., 2004; Wu et al., 1993)	Arrival time deviation (Schönberger et al., 2008; Wang et al., 2011; Zhang et al., 2007)	

Table 2.1 – A summary of the stability metrics in the literature

## 2.2 COST-BASED RE-OPTIMISATION

Let us now consider that the demand of the clients are subject to unexpected changes. Each of such changes is modelled as a deterministic event  $E = \{p^E, \mathcal{D}^E\}$  where  $p^E \in \mathcal{H}$  represents the period for which the event happens and  $\mathcal{D}^E$  represents a set of modified demands. Note that the event always occurs at the beginning of period  $p^E$ .

An example of an event for the example instance of Section 1.1.2 is presented in Table 2.2. Event  $E$  in this case occurs at period  $p = 2$ . Therefore, a re-optimisation is needed for the second and third periods. The demands that are modified compared to Table 1.1 are shown with bold characters. For example, for client 4, demands in periods  $p = 2$  and  $p = 3$  increased to 48 instead of 24, whereas for client 1, demand for period  $p = 2$  turned to 0 instead of 65.

$i$	$D_i^p$		
	$p = 1$	$p = 2$	$p = 3$
1	65	<b>0</b>	65
2	35	35	<b>70</b>
3	58	<b>0</b>	58
4	24	<b>48</b>	<b>48</b>
5	11	<b>0</b>	11

Table 2.2 – A representation of an event for the example instance

In order to face this demand modification, a re-optimisation is needed for horizon  $\mathcal{H}^{\text{new}} = \{p^E, p^E + 1, \dots, |\mathcal{H}|\}$ . To mathematically formulate the re-optimisation problem, let  $\mathcal{S} = \{X_{i,j}^p, Y_i^p, Q_i^p, I_i^p\}$  and  $\mathcal{S}^{\text{new}} = \{x_{i,j}^p, y_i^p, q_i^p, I_i^p\}$  be, respectively, a set of data representing the original solution for the deterministic problem and a set of decision variables for the re-optimisation problem.

---

**Cost-based re-optimisation (IRPR)**

---

$$\min \quad obj^{IRP} = c \sum_{i \in \mathcal{V}} \sum_{j \in \mathcal{V}, i < j} \sum_{p \in \mathcal{H} \setminus \{0\}} x_{i,j}^p \times f(i, j) + \sum_{i \in \mathcal{V}} \sum_{p \in \mathcal{H}} I_i^p \times h_i$$

$$\text{s.t} \quad I_0^p = I_0^{p-1} - \sum_{i \in \mathcal{V} \setminus \{0\}} q_i^p + R^p \quad \forall p \in \mathcal{H}^{\text{new}} \quad (13)$$

$$I_i^p = I_i^{p-1} + q_i^p - D_i^p \quad \forall i \in \mathcal{V} \setminus \{0\}, \forall p \in \mathcal{H}^{\text{new}} \quad (14)$$

$$I_i^p \leq I_i^{\text{max}} \quad \forall i \in \mathcal{V} \setminus \{0\}, \forall p \in \mathcal{H}^{\text{new}} \quad (15)$$

$$q_i^p + I_i^{p-1} \leq I_i^{\text{max}} \quad \forall i \in \mathcal{V} \setminus \{0\}, \forall p \in \mathcal{H}^{\text{new}} \quad (16)$$

$$q_i^p \leq y_i^p \times I_i^{\text{max}} \quad \forall i \in \mathcal{V} \setminus \{0\}, \forall p \in \mathcal{H}^{\text{new}} \quad (17)$$

$$q_0^p \leq y_0^p \times C \quad \forall p \in \mathcal{H}^{\text{new}} \quad (18)$$

$$\sum_{j \in \mathcal{V} \setminus \{0\}} x_{i,j}^p + \sum_{j \in \mathcal{V} \setminus \{0\}} x_{j,i}^p = 2 \times y_i^p \quad \forall i \in \mathcal{V}, \forall p \in \mathcal{H}^{\text{new}} \quad (19)$$

$$\sum_{i \in \mathcal{S}} \sum_{j \in \mathcal{S}, i < j} x_{i,j}^p \leq |\mathcal{S}| - 1 \quad \forall \mathcal{S} \subseteq \mathcal{V} \setminus \{0\}, p \in \mathcal{H}^{\text{new}} \quad (20)$$

(9) to (12)

$$x_{i,j}^p = X_{i,j}^p \quad \forall (i, j) \in \mathcal{E}, \forall p \in \mathcal{H}^{\text{fixed}} \quad (21)$$

$$y_i^p = Y_i^p \quad \forall i \in \mathcal{V}, \forall p \in \mathcal{H}^{\text{fixed}} \quad (22)$$

$$I_i^p = I_i^p \quad \forall i \in \mathcal{V}, \forall p \in \mathcal{H}^{\text{fixed}} \quad (23)$$

$$q_i^p = Q_i^p \quad \forall i \in \mathcal{V}, \forall p \in \mathcal{H}^{\text{fixed}} \quad (24)$$

---

Compared to the original model presented in [Section 1.1.1](#), the cost-based re-optimisation problem time horizon  $\mathcal{H}$  is decomposed in two parts:  $\mathcal{H}^{\text{fixed}} = \{0, 1, \dots, p-1\}$  and  $\mathcal{H}^{\text{new}} = \{p^E, p^E + 1, \dots, |\mathcal{H}|\}$ . In the first part of this time horizon, i.e. before the occurrence of the event, constraints (21) to (24) are added. They fix the decision variables of  $\mathcal{S}^{\text{new}}$  to the values taken by the decision variables in  $\mathcal{S}$ . For the second part of the time horizon, i.e. after the event, the constraints are kept the same as in the IRP model.

Figure 2.1 shows an optimal solution for the example instance faced with the event presented in Table 2.2. This solution is obtained using the model formulated above. The variables regarding period 1 in  $\mathcal{S}^{\text{new}}$  are fixed to the values determined in  $\mathcal{S}$ , since the event occurs at period 2. During  $p = 2$ , client 1 is no longer visited in comparison to the initial solution  $\mathcal{S}$ . Finally, for  $p = 3$ , clients 1, 2 and 4 are visited in this order, instead of 1, 2, 5 and 3.

The problem with this new solution  $\mathcal{S}^{\text{new}}$  is that it can be perceived as too different from solution  $\mathcal{S}$  in terms of solution structure. Therefore, stability metrics are needed to reduce this difference.

### 2.3 ADAPTATION AND MATHEMATICAL FORMULATION OF STABILITY METRICS

In this section, we discuss the relevance for the IRP of the stability metrics found in the literature review carried out in Section 2.1.2. The advantages and drawbacks of these each are analysed. Only those that are judged relevant for the IRP are mathematically formulated and illustrated using the example of Section 1.1.2.

There are several ways to include these metrics in the mathematical formulation of the cost-based re-optimisation presented in Section 2.2: either as objective, as hard constraints or as soft constraints, i.e. integrated to the objective as penalties to be paid each time the metric is violated. In this section, the former option is used: the objectives of the mathematical formulations proposed aim at minimising the violations of the metrics.

#### 2.3.1 Sequence preservation

**DESCRIPTION:** Sequence preservation is an important stability metric used in both scheduling (Wu et al., 1993) and routing problems (Dettenbach et al., 2015). In the literature, it is used as an additional constraint where the sequence (or part of the sequence) of an original solution must be preserved in the re-optimised solution (Dettenbach et al., 2015).

Let us consider an example where clients  $\{a, b, c\}$  are visited in the original solution  $\mathcal{S}$  at period  $p$  with route  $R = \{a - b - c\}$ . The event adds two more clients that should be visited at period  $p$ , thus the set of clients to visit in this route becomes  $\{a, b, c, d, e\}$ . A subset of possible solutions for the re-optimised case would be routes:  $R_1^{\text{new}} = \{a - b - c - d - e\}$ ,  $R_2^{\text{new}} = \{a - b - c - e - d\}$  and  $R_3^{\text{new}} = \{a - d - b - e - c\}$ . A stable solution in this case can be defined by one that minimises the number of violations of the sequence. To compute this number, the edges taken in solution  $\mathcal{S}$  are compared with the ones taken in solution  $\mathcal{S}^{\text{new}}$ . For example, for  $R_1^{\text{new}}$  and  $R_2^{\text{new}}$  the number of violations of the sequence would be equal to 0 since the edges



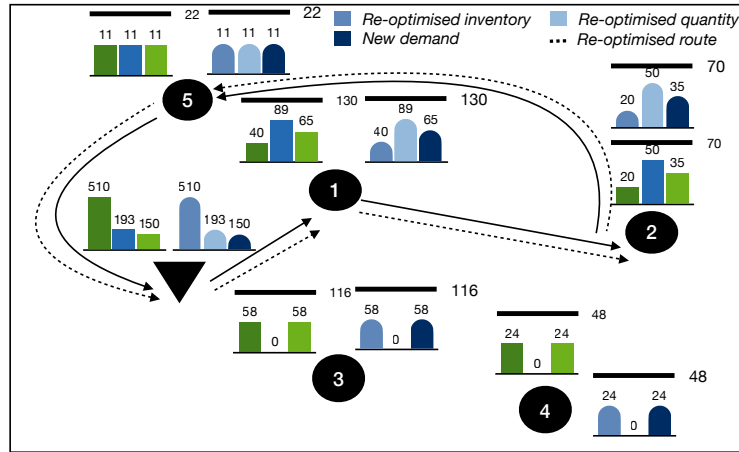

(a)  $p = 1$

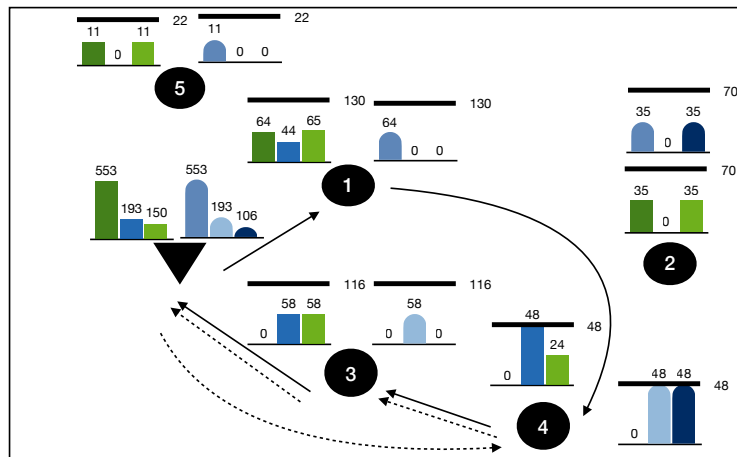

(b)  $p = 2$

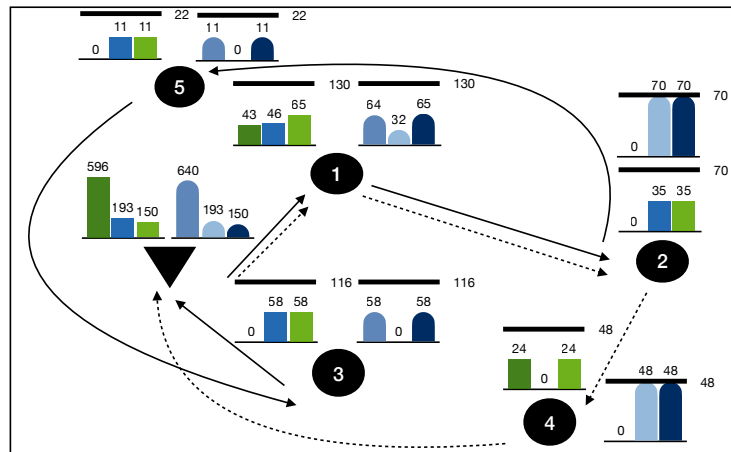

(c)  $p = 3$

Figure 2.1 – A representation of an optimal solution for the re-optimised example instance with the cost as an objective

between  $a$  and  $b$  and between  $b$  and  $c$  exist in  $\mathcal{S}^{\text{new}}$ . However, for  $R_3^{\text{new}}$  it would be equal to 2 since both edges are missing.

**ADVANTAGES:** In urban delivery the products to deliver are generally stored inside the truck following the sequence of the solution so that the products of the first client to visit are the most accessible. Disturbing the original sequence when re-optimising would result in an increase of the visiting time and therefore the duration of the route. Preserving the sequence avoids such issues.

**DRAWBACKS:** A sequence changes only when clients are added to or removed from a route, compared to the original solution. Re-optimising the IRP with sequence preservation therefore implies solving a travelling salesman problem (TSP) when a vertex is inserted, removed or substituted. Because it is well known that an efficient solution of such a modified TSP can be completely different from a solution of the original one (Archetti et al., 2003), preserving the sequence can have a huge impact on the cost of the solution. Another drawback of this metric is that it is mainly external since it has no effect whatsoever on the client.

**MATHEMATICAL FORMULATION:** Let us now mathematically formulate the sequence preservation metric for the IRP. Let  $z_{i,j}^p$  be a binary variable that is equal to 1 if there is a sequence violation, i.e. if edge  $(i, j) \in \mathcal{E}$  is used in a route at period  $i$  in solution  $\mathcal{S}$  but not in  $\mathcal{S}^{\text{new}}$ , or if it is used in  $\mathcal{S}^{\text{new}}$  but not in  $\mathcal{S}$ .

---

### Sequence preservation-based re-optimisation (IRPR-SP)

---

$$\min \sum_{p \in \mathcal{H}^{\text{new}}} \sum_{i \in \mathcal{V}} \sum_{j \in \mathcal{V}, i < j} z_{i,j}^p$$

s.t. (9) to (24)

$$z_{i,j}^p = |X_{i,j}^p - x_{i,j}^p| \quad \forall p \in \mathcal{H}^{\text{new}}, \forall i \in \mathcal{V}, \forall j \in \mathcal{V}, i < j \quad (25)$$

$$z_{i,j}^p \in \{0, 1\} \quad \forall p \in \mathcal{H}^{\text{new}}, \forall i \in \mathcal{V}, \forall j \in \mathcal{V}, i < j \quad (26)$$

---

The IRPR-SP model modifies the formulation of the IRPR by changing the objective function (which becomes the minimisation of the number of sequence violations) and extending it with constraints (25) and (26). Constraints (25) count one violation of sequence if an edge  $(i, j)$  is taken in  $\mathcal{S}$  and not in  $\mathcal{S}^{\text{new}}$  and vice versa; they are not linear,

but we note that a constraint  $z = |x - y|$  can be linearized as follows if  $z$  appears in the minimization objective:

$$z = |x - y| \Leftrightarrow \begin{cases} z \geq x - y \\ z \geq y - x \end{cases}$$

Constraints (26) ensure the binarity of variables  $z_{i,j}^p$ .

Figure 2.2 represents an optimal solution for the example instance using the model IRPR-SP. As in Figure 2.1, the re-optimisation process starts at the second period. In period  $p = 2$ , the same sequence is preserved. However, for  $p = 3$ , there is one sequence violation, due to the addition of client 4 to the tour. Indeed, in this case, arc 1 – 2 is no longer taken and is replaced by the sequence 1 – 4 – 2.

### 2.3.2 Visit deviation

**DESCRIPTION:** Visit deviation is a metric we re-adapt for the IRP and based on the metric presented in Sahin et al. (2008). This metric is not applicable to purely routing problems such as TSP and VRP. Indeed, due to the time dimension of the IRP, it is possible not to visit a client for a certain period, as long as its demand is satisfied, which is not the case for the problems cited previously. The visit deviation quantifies the number of clients that are visited in the re-optimised solution whereas they were not supposed to be in the original one and vice-versa. This metric is mainly external according to Schönberger et al. (2008)'s classification, i.e. it is designed to cater for clients satisfaction.

**ADVANTAGES:** A client which is visited when it was not supposed to be may face some planning issues related to the unavailability of resources such as the human workforce, machinery, parking slots. . . Conversely, expecting a visit that does not actually occur causes a waste of time and resources. Therefore, minimising the visits violation minimises the disruptions for the client and increases the reliability of the supplier from the clients' point of view.

**DRAWBACKS:** Because the visit deviation metric is mainly external, i.e. favours the client's point of view, it does not explicitly ensure any internal stability. Therefore, it cannot guarantee an efficient routing. However, it is worth noting that the visit deviation metric does ensure internal and external stability in inventory management in an implicit way, since not visiting a client that was supposed to be resupplied, or visiting a client that was not supposed to be resupplied, has a negative impact on the stability of the inventory of both the supplier and the client.

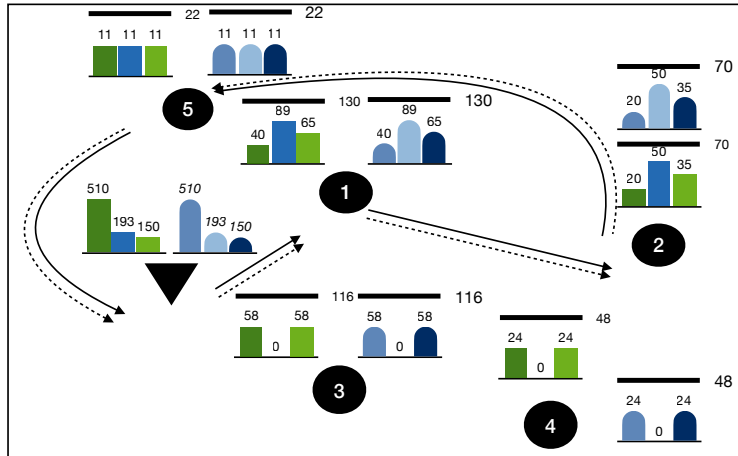

(a)  $p = 1$

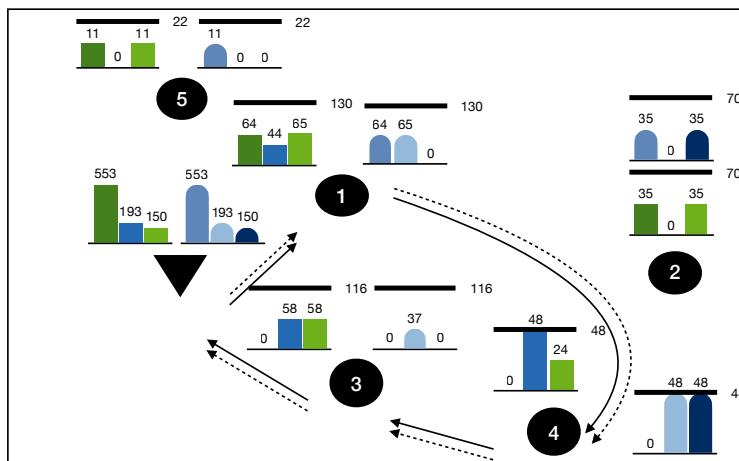

(b)  $p = 2$

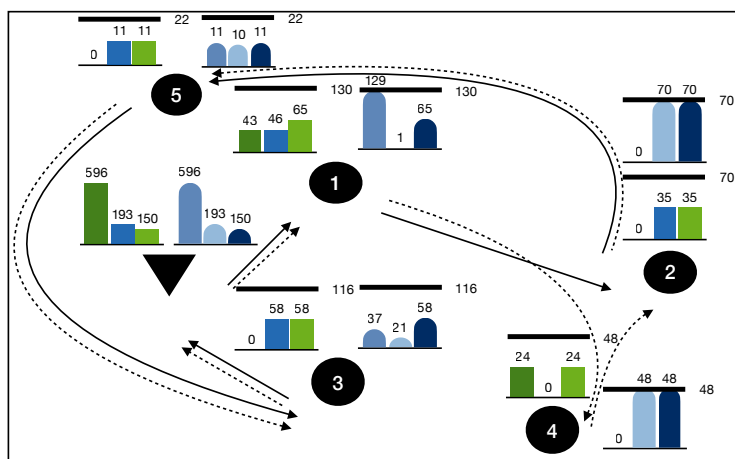

(c)  $p = 3$

Figure 2.2 – A representation of an optimal solution for the re-optimised example instance with the sequence preservation as an objective

Another drawback of the metric is that, in some cases, it can be counterproductive: minimising the visit deviation can lead to a client being visited for no reason (no product being delivered) other than to keep it visited.

**MATHEMATICAL FORMULATION:** Let  $z_i^p$  be a binary variable that is equal to 1 if there is a visit deviation for client  $i$  at period  $p$ , i.e. if it is visited while it was not supposed to be, or if it is not visited while it was supposed to be.

---

**Visit deviation-based re-optimisation (IRPR-VD)**

---

$$\min \sum_{p \in \mathcal{H}^{\text{new}}} \sum_{i \in \mathcal{V} \setminus \{0\}} z_i^p$$

s.t. (9) to (24)

$$z_i^p = |Y_i^p - y_i^p| \quad \forall p \in \mathcal{H}^{\text{new}}, \forall i \in \mathcal{V} \setminus \{0\} \quad (27)$$

$$z_i^p \in \{0, 1\} \quad \forall p \in \mathcal{H}^{\text{new}}, \forall i \in \mathcal{V} \setminus \{0\} \quad (28)$$

---

The objective of the IRPR-VD is the minimisation of the number of visit deviations. It extends the IRPR with constraints (27) and (28). Constraints (27) define a deviation for a client  $i$  in period  $p$  as happening if it is visited in  $\mathcal{S}$  and not visited in  $\mathcal{S}^{\text{new}}$  or vice-versa. It can be linearized as explained before. Constraints (28) ensure the binarity of variables  $z_i^p$ .

An optimal solution of the IRPR-VD of the example instance is presented in Figure 2.3. In period 2 the same clients are visited as in  $\mathcal{S}$ . For period 3, client 4 is visited in addition to clients 1, 2, 3 and 5. Therefore, there is one visit deviation in total, the objective is 1.

### 2.3.3 Quantity received deviation

**DESCRIPTION:** We propose the quantity received deviation as a stability metric for the IRP, in order to address the lack of stability metrics in inventory management previously emphasised in the literature review. This metric computes the difference between the quantity that was supposed to be sent in the original solution and the quantity received in the re-optimised one. This metric is meant to improve the service quality, i.e. it is mainly external.

**ADVANTAGES:** A good point is that when the quantity received deviation is kept at a minimum, fewer planning issues are faced. Indeed, a client receiving less quantity than planned has uselessly mobilised

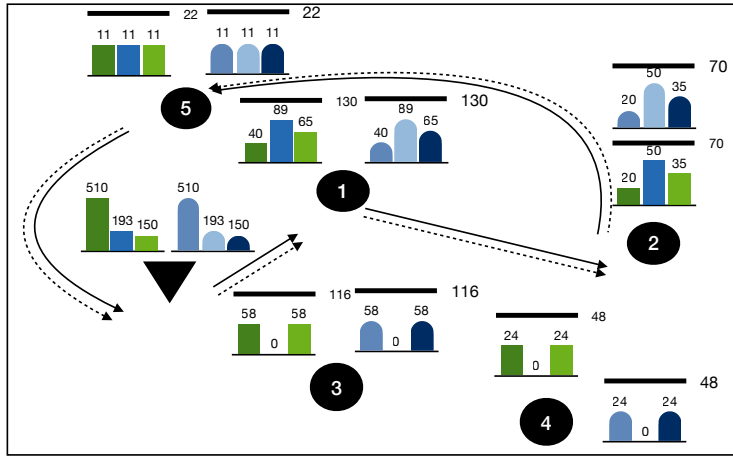

(a)  $p = 1$

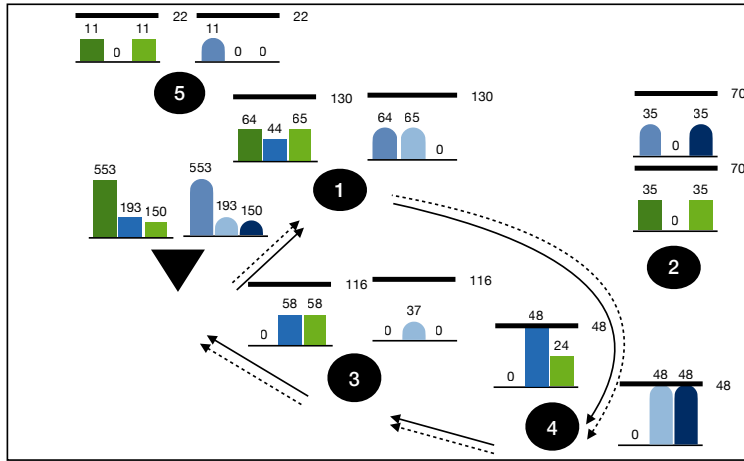

(b)  $p = 2$

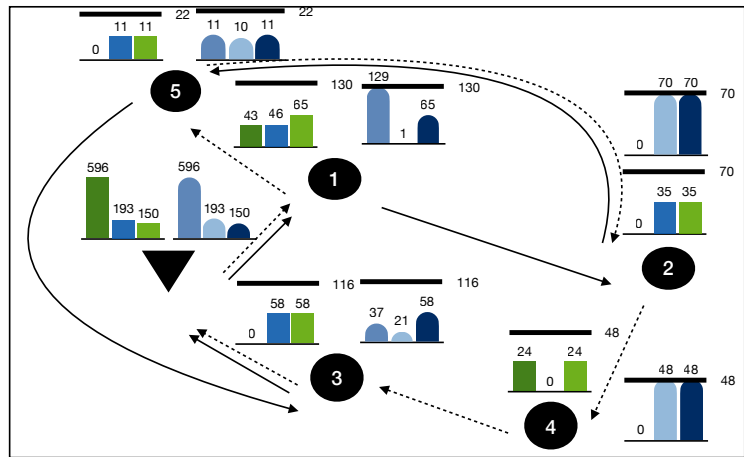

(c)  $p = 3$

Figure 2.3 – A representation of an optimal solution for the re-optimised example instance with the visit deviation as an objective

costly resources for this process. Conversely, if the client receives more products than planned, there might be a shortage of resources which may increase the service time, thus disrupting the entire delivery plan.

This metric is the only one that handles explicitly the inventory management component of the IRP.

**DRAWBACKS:** The logic behind VMI is to let the decision maker, who has the best overview of the network, decide whom to serve and with which quantity. However, when limiting the value of the quantity deviation metric, such flexibility is somewhat constrained. Note that, although this drawback exists for all the metrics proposed, we believe that it is much more significant in the case of quantity deviation.

**MATHEMATICAL FORMULATION:** let  $\tilde{q}_i^p \in \mathbb{R}$  be the quantity received deviation, i.e. the difference of quantity received by client  $i$  at period  $p$ , between the original solution and the re-optimised one.

---

#### Quantity deviation-based re-optimisation (IRPR-QD)

---

$$\min \sum_{p \in \mathcal{H}^{\text{new}}} \sum_{i \in \mathcal{V} \setminus \{0\}} \tilde{q}_i^p$$

$$\text{s.t.} \quad (9) \text{ to } (24)$$

$$\tilde{q}_i^p = |Q_i^p - q_i^p| \quad \forall p \in \mathcal{H}^{\text{new}}, \forall i \in \mathcal{V} \setminus \{0\} \quad (29)$$

$$\tilde{q}_i^p \geq 0 \quad \forall p \in \mathcal{H}^{\text{new}}, \forall i \in \mathcal{V} \setminus \{0\} \quad (30)$$



---

The objective of the IRPR-QD is to minimise the total quantity deviations. Compared to the IRPR, it adds constraints (29) and (30). Constraints (29) compute the difference between the quantity planned in solution  $\mathcal{S}$  and received in  $\mathcal{S}^{\text{new}}$ . These constraints can easily be linearised as mentioned before. Constraints (30) ensure the non-negativity of variables  $\tilde{q}_i^p$ .

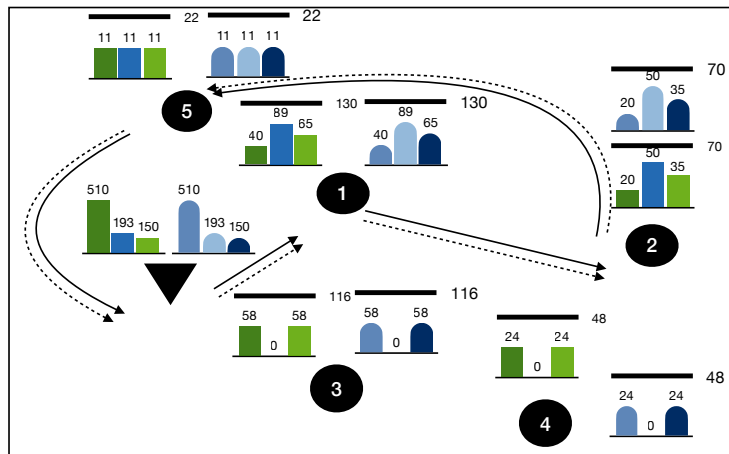
An optimal solution of the IRP-QD of the example instance is presented in [Figure 2.4](#). The differences in quantity occur in period  $p = 3$  just as in  $SP$  and  $VD$ . For example, client 1 receives 22 instead of 46. The total amount of the differences over all the clients sums up to 166.

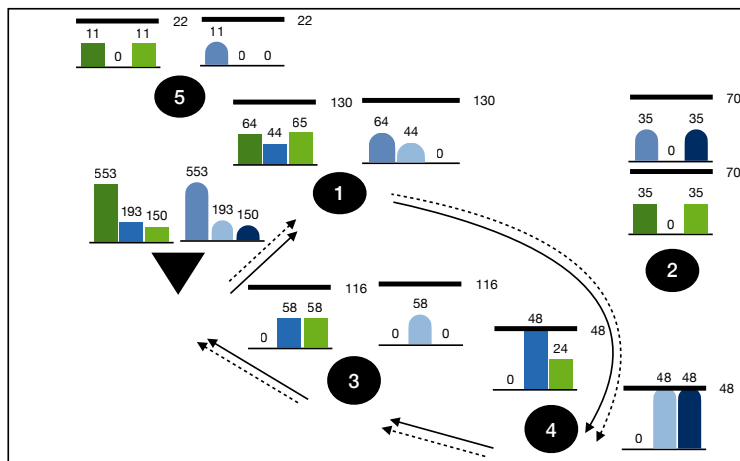

(a)  $p = 1$



(b)  $p = 2$

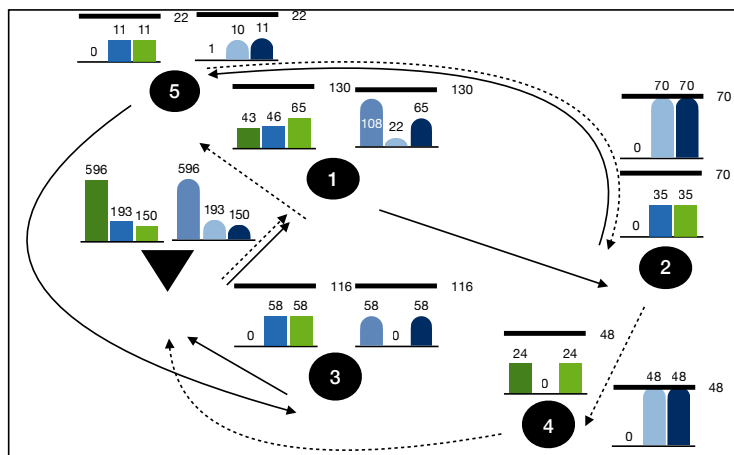

(c)  $p = 3$

Figure 2.4 – A representation of an optimal solution for the re-optimised example instance with the quantity deviation as an objective



### 2.3.4 Clients re-allocation

**DESCRIPTION:** In urban delivery, and when considering a fleet of vehicles, the network of clients can be decomposed in different districts. A driver in this case is generally allocated to clients that belong to a single district, so that drivers can get familiar with the area traffic, shortcuts, as well as the specific requirements of the clients.

When re-optimising, a way to achieve stability is to minimise the re-allocations of clients to drivers from other areas. The computation of the number of re-allocations is as follows: one occurs for each visited client in  $\mathcal{S}$ , if the driver is no longer the same in  $\mathcal{S}^{\text{new}}$ . This metric is a re-adaptation of the “Resource Assignment Nervousness” presented in Schönberger et al. (2008).

**ADVANTAGES:** When the clients re-allocation metric is kept at a minimum, the driver is less disturbed by the events, which enhances his/her performance as well as the satisfaction of the client.

**DRAWBACKS:** In the IRP, clients that were not visited in the original plan can be added to a route in the re-optimised solution, or clients that were previously visited can be removed from the route. This will not affect the clients re-allocation metric at all, since the clients re-allocation metric changes only when a client is visited in both  $\mathcal{S}$  and  $\mathcal{S}^{\text{new}}$  but with different vehicles. For example, let  $\mathcal{K}_1 = \{a, b, c, d\}$  and  $\mathcal{K}_2 = \{e, f, g\}$  be the sets of clients visited by vehicle 1 and 2, respectively, in  $\mathcal{S}$ . If in  $\mathcal{S}^{\text{new}}$ ,  $\mathcal{K}_1^{\text{new}} = \{a, b, c\}$  and  $\mathcal{K}_2^{\text{new}} = \{e, f, g, h\}$ , the number of visited clients that are allocated to different vehicles is equal to zero, even if client  $d$  has been removed and client  $h$  added. This example shows the limitations of this metric, that does not detect some big differences between  $\mathcal{S}$  and  $\mathcal{S}^{\text{new}}$ .

We do not propose a mathematical formulation for the client re-allocation metric because we chose to focus on a variant of the IRP where only one vehicle is used (see model in Section 2.2), whereas the client re-allocation metric is only compatible with multi-vehicle variants.

### 2.3.5 Edit distance

**DESCRIPTION:** As mentioned in Section 2.1.2, the idea behind the edit distance in Sørensen’s work (Sørensen, 2006) is to minimise the number of operations (addition, deletion, substitution) that transform the original solution into the re-optimised one. This metric is easily adapted to the case of the IRP.

**ADVANTAGES:** The advantage of this stability metric is mostly computational: the operators used to compute the edit distance (addition,

deletion and substitution) could be used within a local search procedure. Local search algorithms are known to be very efficient heuristics for sequencing problems, therefore they can help solving routing component of the IRP.

**DRAWBACKS:** Let us take the example of a time period in which to visit client  $\{a, b, c\}$  should be visited, with route  $R = \{a - b - c\}$  as initial solution. Considering the addition of two clients  $\{d, e\}$ , routes  $R_1^{\text{new}} = \{a - b - c - d - e\}$  and  $R_2^{\text{new}} = \{a - d - b - e - c\}$  can both be obtained by performing two addition operations. For  $R_1^{\text{new}}$ ,  $d$  and  $e$  are inserted to the end of the sequence, whereas for  $R_2^{\text{new}}$ ,  $d$  and  $e$  are inserted, respectively, between  $a - b$  and  $b - c$ . One could argue that  $R_1^{\text{new}}$  represents a more stable solution than  $R_2^{\text{new}}$  as it does not change the initial sequence. However, the edit distance metric cannot differentiate between them.

Another drawback of the edit distance metric is that it is generally considered as an indicator of stability and not an active optimisation criterion. This is due to the NP-hardness of defining the optimal edit distance for  $\mathcal{S}^{\text{new}}$  in relation to  $\mathcal{S}$  (Sörensen, 2006). Therefore, we do not see how to propose a linear model that optimises the edit distance and do not propose a mathematical formulation for the edit distance metric.

### 2.3.6 *Delivery system modification*

**DESCRIPTION:** Delivery system modification as a metric can be considered only when deliveries can be subcontracted, e.g. for the IRP with transshipment. It is adapted from the “Mode Selection Nervousness” metric presented in Schönberger et al. (2008). It quantifies variations in the mode of delivery between the original solution and the re-optimised one by counting the number of clients that are visited by the supplier’s own fleet in  $\mathcal{S}^{\text{new}}$  rather than a subcontractor, or that are visited by a subcontractor instead of the supplier’s fleet.

**ADVANTAGES:** This metric helps limiting the changes in resources between the original and the re-optimised solutions. Indeed, the decision maker has to determine how many drivers/owned vehicles he/she will need to perform the routes of the solution, as well as the number of transshipments. Minimising the modifications in the delivery system should avoid contractual issues with the transportation provider if deliveries that were supposed to be outsourced are actually managed internally, or vice versa.

**DRAWBACKS:** The main drawback of the delivery system modification metric is that it can only be considered within a variant of the IRP, i.e. when transshipment is possible. In addition, it does not en-

sure any external stability. Indeed, it does not usually matter for a client whether the delivery is made by a subcontractor or an owned vehicle, as long as the right quantity is received.

The delivery system modification metric is compatible only with variants of the IRP where transshipment is considered. Therefore, no mathematical formulation is proposed for this metric.

### 2.3.7 *Visiting time deviation*

**DESCRIPTION:** The visiting time deviation metric can be considered when time-related considerations, such as travel times, arrival times, etc, are explicitly modelled in the IRP. This metric sums the differences, for each client, between the time of visit in the initial solution and the re-optimised one.

**ADVANTAGES:** The advantage of this metric is twofold. First, when the visiting time deviations are at a minimum, the client is more satisfied, since the resulting plan does not disturb too much its schedule regarding closing time, other deliveries, unavailability of resources. . .

Second, it ensures, indirectly, some internal stability. Indeed, in order to minimise the deviations in the time of visit, the paths of the drivers must not undergo heavy changes.

**DRAWBACKS:** The only drawback of this metric is that it does not ensure any stability in terms of inventory management. However, it is very efficient for the routing component of the IRP since it ensures both internal and external stability.

The visiting time deviation as a metric is only relevant when the time aspect is considered for the routing component. Therefore, we do not propose a mathematical formulation due to its incompatibility with our variant of the IRP.

### 2.3.8 *A qualitative discussion*

The panel of stability metrics presented in this section ensure a large range of stability for the IRP and are compatible with different variants. As a summary, [Table 2.3](#) shows, for each stability metric proposed, if an internal or external stability in both routing and inventory management is ensured, if it is compatible with the three most commonly used variants of the IRP in the literature, respectively, IRP (multi-vehicle included), IRP with transshipment (IRPT) and IRP with time windows (IRPTW) and finally, if a Mixed Integer Linear Programm (MILP) is proposed for the metric. For example, visit deviation ensures external stability in both routing and inventory management and internal stability in inventory management. It is also compatible with every variant of the IRP. For the sequence

preservation on the other hand, although it can be compatible with all the variants of the IRP, it only ensures internal routing stability. The last column shows that MILP models are proposed for three metrics only, namely, sequence preservation, visit deviation and quantity deviation. This is due to the incompatibility of some of the metrics with the variant of the IRP proposed in this paper (client re-allocation, delivery system modification and visiting time deviation) or to their non linearity (edit distance).

	Routing		Inv. management		Problem variants			Proposed
	Internal	External	Internal	External	IRP	IRPT	IRPTW	MILP model
Sequence preservation	✓				✓	✓	✓	✓
Visit deviation		✓	✓	✓	✓	✓	✓	✓
Quantity received deviation			✓	✓	✓	✓	✓	✓
Clients re-allocation		✓			✓	✓	✓	
Edit distance	✓				✓	✓	✓	
Delivery system modification	✓					✓		
Visiting time deviation	✓	✓					✓	

Table 2.3 – Categorisation of the IRP stability metrics

It appears from Table 2.3 that no stability metric is able to ensure internal and external stability in both routing and inventory management. Therefore, ensuring the full range of stability for a certain variant of the IRP can be a tedious task. For example, combining sequence preservation, visit deviation and quantity deviation does ensure the full range of stability. However, including all of them to an optimisation model comes with its challenges. If the metrics are considered as hard constraints, it is very complicated to determine a thresh-hold of stability for the metrics that ensures that a feasible solution can be obtained. On the other hand, if they are considered as soft constraints, it is difficult to define an appropriate weight for each metric. Therefore, in the next section, we propose a way to compare the stability metrics by investigating their behaviour in relation to each other and to the initial objective function, the cost. The objective of this comparison is to determine if there is a dominance relationship between the metrics in order to eliminate the dominated or the redundant ones.

## 2.4 COMPARISON OF STABILITY METRICS

In this section, experiments are conducted in order to compare the stability metrics. To that purpose, the benchmark used is de-

scribed in [Section 2.4.1](#), a dominance function is introduced in [Section 2.4.2](#), then experimental results are presented and discussed in [Section 2.4.3](#).

All experiments are conducted on a CPU Intel Xeon E5-1620 v3 @3.5Ghz with 64GB RAM using the branch-and-cut procedure presented in [Algorithm 1.1](#) and with a 600 seconds time limit. The subtour elimination constraints are added dynamically using Gurobi 9.0.0 as a solver with the lazyConstraints parameter. All models are implemented with Java in Eclipse IDE.

Note that only three metrics here are compared, namely, sequence preservation, visit deviation and quantity deviation. As explained in [Section 2.3](#) and shown in [Table 2.3](#), these metrics are the only ones judged both relevant and compatible with the IRP variant considered in this paper.

#### 2.4.1 Benchmark

To model the initial problem before unexpected events happen, we use the benchmark proposed by Archetti et al. (2007), which is the most commonly used in the literature. [Table 2.4](#) describes the characteristics of the instances used. There are two different time horizons ( $|\mathcal{H}| = 3$  and 6 periods), and different possible numbers of clients  $|\mathcal{V}|$  for each time horizon. The holding cost  $h$  is significantly higher in half of the instances. For each combination  $(|\mathcal{H}|, |\mathcal{V}|, h)$ , five (#instances) instances exist, on which ten (#events) events are generated for three different sets of scenarios. For example, for  $|\mathcal{H}| = 3$  and  $|\mathcal{V}| = 5$ , there are 5 different instances when the holding cost  $h$  is low and 5 others when it is high. For each one of these 10 different instances, 10 events for each scenario are generated, which makes the total number of instances for  $|\mathcal{H}| = 3$  and  $|\mathcal{V}| = 5$  equal to  $10 \times 10 \times 3 = 300$ . With all combinations considered, the total number of instances is equal to 3000.

$ \mathcal{H} $	$ \mathcal{V} $	$h$	#instances	scenarios	#events per scenario
3	{5, 10, 20, 30, 40, 50}	{high, low}	5	{1, 2, 3}	10
6	{5, 10, 20, 30}				

Table 2.4 – A description of the benchmark set of the numerical experiments

The three different scenarios considered to generate the events are presented in [Table 2.5](#). The table gives the percentage of clients that change their demand in each scenario; the columns shows the demand variation in each case. For example, in scenario 1, the demand of each client have a probability of 0.1 to become 0, a probability of 0.8

to stay the same and a probability of 0.1 to double. These variations are rather drastic to ensure that significant changes can be observed in the structure of the re-optimised solution. The procedure to generate an event is presented in [Algorithm 2.1](#).

Scenario	Demand				
	$\times 0$	$\times 0.5$	$\times 1$	$\times 1.5$	$\times 2$
1	10%	-	80%	-	10%
2	15%	10%	50%	10%	15%
3	30%	-	40%	-	30%

Table 2.5 – A description of the different event scenarios

---

**Algorithm 2.1:** Generation of an event

---

- 1: **input:** An instance,  $u$  index of the scenario
  - 2: randomly generate a period  $p^E$  where  $p^E \in \mathcal{H}$
  - 3: **for**  $p \in \{p^E, p^E + 1, \dots, |\mathcal{H}|\}$  **do**
  - 4:   **for**  $i \in \mathcal{V} \setminus \{0\}$  **do**
  - 5:     Depending on the scenario  $u$ ,  $D_i^p$  is modified according to [Table 2.5](#)
  - 6:   **end for**
  - 7: **end for**
  - 8: **return**
- 

#### 2.4.2 A dominance function

Let  $w$  be an instance of the problem,  $\mathcal{W}$  a set of instances, and  $\mathcal{F} = \{f_1, f_2, \dots, f_{|\mathcal{F}|}\}$  a set of metrics. An optimal solution of instance  $w$  with the metric  $f_v \in \mathcal{F}$  as an objective function is denoted by  $f_v^*(w)$ . We denote by  $f_{v'}^*(w|f_v^*(w))$  the optimal solution of instance  $w$  with metric  $f_{v'}$  as objective function, metric  $f_v$  being kept at its optimal value  $f_v^*(w)$  through an added constraint.

The dominance of metric  $f_v$  over metric  $f_{v'}$  for set  $\mathcal{W}$  is denoted as  $f_v \succ^{\mathcal{W}} f_{v'}$ . A metric  $f_v$  dominates a metric  $f_{v'}$  for set  $\mathcal{W}$  if and only if for all instances  $w \in \mathcal{W}$  it is possible to find the optimal solution for metric  $f_{v'}$  when metric  $f_v$  is fixed to its optimal value, i.e.  $f_{v'}^*(w) = f_{v'}^*(w|f_v^*(w))$ .

Let us now set  $|\mathcal{F}| = 4$  and  $f_1 = \hat{C}$ ,  $f_2 = SP$ ,  $f_3 = VD$  and  $f_4 = QD$  where  $\hat{C}$  is the cost,  $SP$  the sequence preservation,  $VD$  the visit deviation and  $QD$  the quantity deviation. In order to compare these metrics, the instances of the benchmark need to be solved to optimality for each metric, and then for each metric fixed to its optimal value through an added constraint, the other metrics are solved

to optimality. The procedure for one instance and one event is presented in [Algorithm 2.2](#) and [Table 2.6](#): it starts by solving the initial problem and obtaining the initial solution  $\mathcal{S}$ . Afterwards, for each metric  $f_v \in \mathcal{F}$  the re-optimisation solution  $\mathcal{S}_{f_v}^{\text{new}}$  is obtained from the initial solution  $\mathcal{S}$  and the event  $E^w$  and the optimal value of the metric  $f_v^*$  is obtained. For the remaining metrics  $f_{v'}$ , a new re-optimisation problem is solved, where the value of metric  $f_v^{\text{new}}$  of index  $v$  is fixed to its optimal value  $f_v^*$ . The results of this procedure is a matrix  $\mathcal{M}$  of dimensions  $|\mathcal{F}| \times |\mathcal{F}|$  ([Table 2.6](#)).

As an illustration, in [Table 2.6](#), cell  $SP^*$  contains the optimal solution when the objective is to minimise the sequence preservation, cell  $SP^*(VD^*)$  contains the optimal solution when the objective is to minimise the sequence preservation while keeping the visit deviation at its optimal value  $VD^*$ , and finally,  $VD^*(SP^*)$  contains the optimal solution of the visit deviation when the sequence preservation is kept at its optimal value.

---

**Algorithm 2.2:** A description of the solving procedure for an instance  $w \in \mathcal{W}$

---

- 1: **input:** An instance  $w \in \mathcal{W}$ , one of its events  $E^w$ , an empty matrix  $\mathcal{M}$  of  $|\mathcal{F}| \times |\mathcal{F}|$  dimension
  - 2: solve the initial problem to get  $\mathcal{S}$  as optimal solution
  - 3: **for**  $f_v \in |\mathcal{F}|$  **do**
  - 4:   solve to get  $\mathcal{S}_{f_v}^{\text{new}}(E^w, \mathcal{S})$  and set  $\mathcal{M}_{f_v, f_v}$  to  $f_v^*(w)$
  - 5:   **for**  $f_{v'} \in |\mathcal{F}|, f_{v'} \neq f_v$  **do**
  - 6:     add the constraint  $f_v^{\text{new}}(w) = f_v^*(w)$
  - 7:     solve to get  $\mathcal{S}_{f_{v'}}^{\text{new}}(E^w, \mathcal{S} | f_v^*(w))$  and set  $\mathcal{M}_{f_v, f_{v'}}$  to  $f_{v'}^*(w) | f_v^*$
  - 8:   **end for**
  - 9: **end for**
  - 10: **return**  $\mathcal{M}$
- 

	$\hat{C}$	$SP$	$VD$	$QD$
$\hat{C}$	$\hat{C}^*$	$SP^*(\hat{C}^*)$	$VD^*(\hat{C}^*)$	$QD^*(\hat{C}^*)$
$SP$	$\hat{C}^*(SP^*)$	$SP^*$	$VD^*(SP^*)$	$QD^*(SP^*)$
$VD$	$\hat{C}^*(VD^*)$	$SP^*(VD^*)$	$VD^*$	$QD^*(VD^*)$
$QD$	$\hat{C}^*(QD^*)$	$SP^*(QD^*)$	$VD^*(QD^*)$	$QD^*$

Table 2.6 – Structure of matrix  $\mathcal{M}$  for one instance and one of its events

An example for an instance where  $|\mathcal{H}| = 6$  and  $|\mathcal{V}| = 30$ , subjected to an event drawn from the probability distribution of scenario 1, is presented in [Table 2.7](#). It shows that  $VD \succ^w SP$ , since  $SP^* = SP^*(VD^*) = 0$  and that  $SP \succ^w VD$ , since  $VD^* = VD^*(SP^*) = 3$ .

Therefore, a dominance relation exists between  $SP$  and  $VD$  in both ways, thus it is not a strict one. These two metrics can be said to be equivalent, i.e. optimising the sequence preservation first does not keep us from finding the optimal solution for visit deviation and vice-versa. Furthermore, observation of metrics  $QD$  and  $VD$  shows these metrics to be divergent, i.e. optimising one deteriorates the other.

	$\hat{C}$	$SP$	$VD$	$QD$
$\hat{C}$	8328.03	7	8	1334
$SP$	8456.58	0	3	468
$VD$	9016.52	0	3	764
$QD$	9399.88	0	6	468

Table 2.7 – Results for an instance where  $|\mathcal{H}| = 6$  and  $|\mathcal{V}| = 30$

### 2.4.3 Experimental results and discussion

COMPARISON OF  $SP$ ,  $VD$  AND  $QD$ . All 3000 instances of set  $\mathcal{W}$  are subjected to the procedure described in Algorithm 2.2, solving  $|\mathcal{F}| \times |\mathcal{F}| = 16$  MILPs for each instance. The results are presented in Table 2.8 where each cell represents the ratio of instances where  $f_v$  dominates  $f_{v'}$ .

$\succ^{\mathcal{W}}$	$\hat{C}$	$SP$	$VD$	$QD$
$\hat{C}$	-	31.77 %	20.87 %	13.12 %
$SP$	31.77 %	-	95.33 %	95.19 %
$VD$	20.87 %	95.33 %	-	89.04 %
$QD$	13.12 %	95.19 %	89.04 %	-

Table 2.8 – Dominance results between the stability metrics and the cost

Table 2.8 shows a high rate of equivalence between the stability metrics, namely, sequence preservation, visit deviation and quantity deviation. Indeed, for sequence preservation, there is an equivalence rate of 95% with both visit deviation (96.33%) and quantity deviation (95.19%). This means that divergences happen in only 5% of the cases: in these cases, optimising sequence preservation deteriorates visit deviation and/or quantity deviation (and vice-versa). Moreover, although the rate of equivalence between visit deviation and quantity deviation drops to 89% it is still very strong. This amount of equivalence was intuitively expected due to the interrelationship of the mathematical formulations of the stability metrics.



Since keeping a plan stable is supposed to be costly, low equivalence rates were intuitively expected between the cost and the stability metrics. Yet, the results show the cost to be equivalent for, respectively, 30%, 20% and 13% of the cases for sequence preservation, visit deviation and quantity deviation. To deepen this analysis, we thus take a closer look at the evolution of the cost in comparison to the stability metrics when they are divergent. For each instance  $w \in \mathcal{W}$ , the gap between the optimal cost and the optimal cost when a stability metric is kept at its optimal value  $g_{f_v}^{\hat{C}}$  is computed. For example, for the case of cost and sequence preservation:  $g_{SP}^{\hat{C}} = \frac{\hat{C}^*(SP^*) - \hat{C}^*}{\hat{C}^*}$ . Figure 2.5 represent the distribution of these gaps for, respectively, sequence preservation, visit deviation and quantity deviation when the cost and these metrics are divergent, i.e. 68.23% of the instances for *SP*, 79.13% for *VD* and 86.88% for *QD*.

Figure 2.5a shows the distribution of the gap in the cost regarding *SP*. We can see that almost 37% of the instances have a gap in the cost inferior to 2.5% and almost 25% when the gap is between 2.5% and 5%. Therefore, for 60% of the instances, the cost is deteriorated only up to 5% when *SP* is optimal. Furthermore, almost 20% of the instances have a gap within 5% and 10%. On the other hand, less than 1% of the instances have a gap superior to 30%. A similar distribution is observed for both *VD* and *QD* for the cost gap interval  $]5, +\infty[$ . However, for the interval  $]0, 10]$  it goes up to 66% for *VD* and up to 70% for *QD*. It is worth noting that the choice was made not to include the ratio of the instances where there is an equivalence between the cost and the stability metrics to show that the histograms have the same shape when there is divergence. Table 2.9 shows the distribution of the gap in cost in relation to the stability metrics for all the instances, including when there is an equivalence, i.e.  $g_{f_v}^{\hat{C}} = 0$ .

	$g_{f_v}^{\hat{C}} \%$										
	= 0	]0, 2.5]	]2.5, 5]	]5, 7.5]	]7.5, 10]	]10, 12.5]	]12.5, 15]	]15, 17.5]	]17.5, 20]	]20, 30]	$\geq 30$
<i>SP</i>	31.77	25.16	15.60	10.13	6.32	3.49	2.73	1.69	1.04	1.55	0.57
<i>VD</i>	20.87	34.07	18.43	10.53	5.75	3.43	2.75	1.57	0.89	1.29	0.46
<i>QD</i>	13.12	40.59	20.53	10.46	5.51	3.10	2.56	1.14	0.82	1.57	0.64

Table 2.9 – Distribution of the gap in the cost for *SP*, *VD* and *QD*

Two conclusions can be drawn from Table 2.9. First, the difference in equivalence rate between the stability metrics and the cost is due to very small deviations in the cost. Indeed, the distribution of the gap in the cost for interval  $]5, +\infty[$  is the same for all three metrics. The only difference is observed in interval  $]0, 5]$  where the difference in equivalence rate between *SP* and *VD* is shifted to a gap smaller than

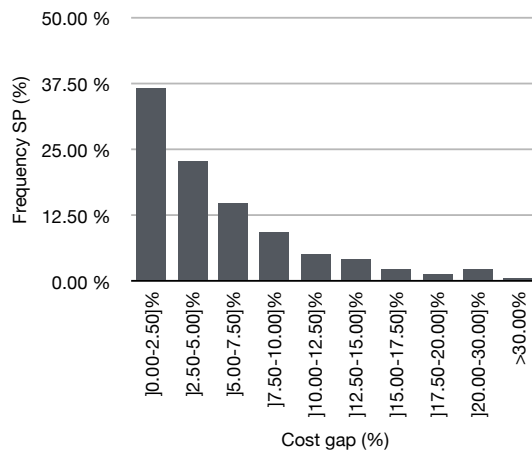

(a) Sequence preservation  $SP$

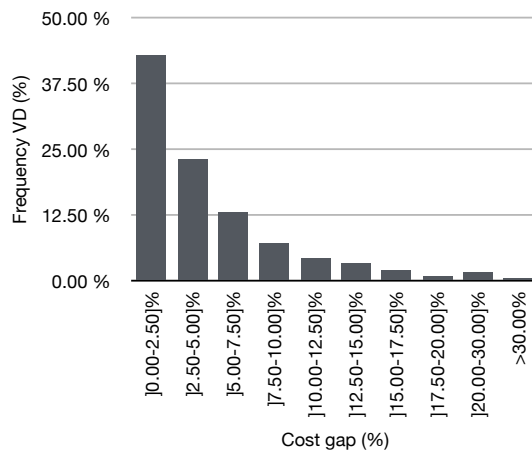

(b) Sequence preservation  $VD$

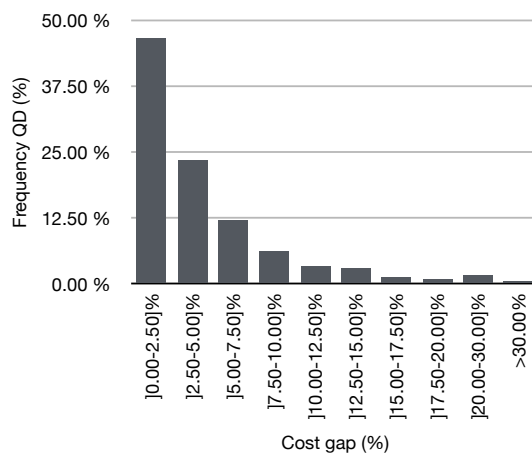

(c) Sequence preservation  $QD$

Figure 2.5 – A representation of the distribution of the gap in the cost when the cost and the stability metrics  $SP$ ,  $VD$  and  $QD$  are divergent

5%. The other conclusion is that the performance of re-optimising with the stability metrics depend on the decision maker. If the decision maker accepts the deterioration of the cost of the solution up to a certain threshold in order to ensure the stability of the solutions, the results show that if the threshold is fixed to 5%, in almost 75% of the instances optimising stability yields an acceptable cost. This rate goes up to almost 90% when the threshold is fixed to 10%.

To ensure that these results can be generalised, at least for set  $\mathcal{W}$ , a decomposition of the results is performed for the different parameters of the benchmark: number of clients  $|\mathcal{V}|$ , event scenario (1, 2 or 3) and the size of horizon  $|\mathcal{H}|$ . For the equivalence rates presented in Table 2.8, the results stay the same no matter which event scenario is performed. On the other hand, the number of clients and the horizon size have an impact on the equivalence rates between the cost and the stability metrics. For example, when  $|\mathcal{V}| = 5$ , for  $|\mathcal{H}| = 3$  the equivalence rates between cost and  $SP$ ,  $VD$  and  $QD$  are, respectively, 52%, 53% and 40% and drop to 31%, 37% and 27% for  $|\mathcal{H}| = 6$ . When  $|\mathcal{V}| = 30$ , for  $|\mathcal{H}| = 3$ , the equivalence rates are 28%, 11% and 4% and drop to 20%, 5% and 2% for  $|\mathcal{H}| = 6$ . This means that the larger the instances get, in terms of number of clients or size of the time horizon, the smaller the equivalence rate becomes. However, these two parameters do not have any impact on the distribution of the cost, as 90% of the solutions lead to a solution with a gap in the cost inferior to 10%.

ON THE HARDNESS OF THE RE-OPTIMISATION PROBLEM. Another observation that is worth mentioning is the difficulty of solving the re-optimisation problems. Because the re-optimisation problems lead to models that are smaller than the original ones, part of the variables being fixed, we intuitively expected them to be easier to solve. However, Table 2.10 shows that, contrary to the original MILPs, some re-optimisation MILPs are not solved to optimality in the given time limit (600 seconds). For example, when the objective of the re-optimisation is to minimise cost  $\hat{C}$ , 2884 instances out of 3000 are solved to optimality.

	$\hat{C}$	$SP$	$VD$	$QD$
$\hat{C}$	2884	2841	2841	2832
$SP$	2830	2941	2941	2940
$VD$	2945	2945	2945	2945
$QD$	2945	2945	2945	2945

Table 2.10 – Number of optimal solutions (out of 3000 instances)

We believe this difficulty of solving the re-optimisation problem comes from the demand change rather than from the stability measures added to the problem. To validate this intuition, the instances of the benchmark are solved when the demand is constant (as defined in the benchmark of Archetti et al. (2007)), and then when the demand is modified for the whole horizon  $\mathcal{H}$  according to scenario 1 presented in Table 2.5. The performances for both cases are compared in Table 2.11 where column  $|\mathcal{V}|$  represents the number of clients,  $|\mathcal{H}|$  the horizon,  $h_i$  indicates whether the holding cost is low (-) or high (+). Columns  $\hat{C}_{LR}$ ,  $\hat{C}_{MILP}$ ,  $g$ ,  $cpu(s)$ ,  $\underline{g}$  represent, respectively, the linear relaxation at the root node, the objective value of the MILP, the gap between the optimal solution and the best bound found, the execution time and finally the gap between the optimal solution and the bound at the root node, i.e.  $\underline{g} = \frac{\hat{C}_{MILP} - \hat{C}_{LR}}{\hat{C}_{LR}}$ , for the instance with constant demand. The next columns, marked with exponent  $.^{new}$ , display those same indicators for the instance with modified demands.

Table 2.11 shows that the model performs better with constant demand as the linear relaxations are tighter. Indeed, the instances of the benchmark provided by Archetti et al. (2007) are generated so that for each  $p \in \mathcal{H}$ :

1. the demand for a client  $i \in \mathcal{V} \setminus \{0\}$  is constant:  $\forall p \in \mathcal{H} \setminus \{0\} D_i^p = D_i$
2. the vehicle capacity is three halves of the total demand for a period  $p$ :  $C = \frac{3}{2} \times \sum_{i \in \mathcal{V} \setminus \{0\}} D_i^p$
3. the quantity produced by the supplier for a period  $p$  is equal to the total demand for that period:  $R^p = \sum_{i \in \mathcal{V} \setminus \{0\}} D_i^p$
4. the inventory capacity is equal to twice or three times the demand for a period  $p$ :  $I_i^{\max} = \{2, 3\} \times D_i^p$
5. the initial inventory is equal to the inventory capacity minus the demand for one period:  $S_i^0 = I_i^{\max} - D_i$

Assumption 2 combined with assumption 3 makes it possible to replenish all clients at any period of the horizon  $\mathcal{H}$  at least to satisfy their demands for the period in question. Assumptions 4 and 5 on the other hand ensure that when  $|\mathcal{H}| = 3$  for example, only one delivery for each client can satisfy its demand for the whole horizon. All of the above make Archetti et al. (2007)'s instances easier to solve. However, in the case where the demand is not constant anymore, as it is the case in the re-optimisation problem, these assumptions do not hold anymore. Therefore, we believe that it is necessary to propose a new benchmark of the IRP that is more realistic, the assumptions cited above being rarely met in a real-life instances.

$ V $	$ H $	$h_i$	$\hat{C}_{LR}$	$\hat{C}_{MILP}$	$g$	$cpu(s)$	$\underline{g}$	$\hat{C}_{LR}^{new}$	$\hat{C}_{MILP}^{new}$	$g^{new}$	$cpu^{new}(s)$	$\underline{g}^{new}$
5	3	-	1192.57	1275.86	0.00	0.02	6.98%	1233.02	1262.30	0.00	0.00	2.37%
		+	2117.02	2199.90	0.00	0.02	3.91%	2199.98	2233.86	0.00	0.00	1.54%
	6	-	2931.20	3136.90	0.00	0.12	7.02%	2984.02	3252.84	0.00	0.09	9.01%
		+	5122.98	5354.20	0.00	0.12	4.51%	5102.35	5465.49	0.00	0.08	7.12%
		-	1880.44	1910.93	0.00	0.02	1.62%	2017.66	2143.10	0.00	0.01	6.22%
		+	4310.50	4337.97	0.00	0.02	0.64%	4647.16	4830.34	0.00	0.01	3.94%
10	6	-	4468.22	4612.50	0.00	0.30	3.23%	4709.40	5394.20	0.00	0.14	14.54%
		+	8404.77	8601.92	0.00	0.32	2.35%	8494.23	8950.21	0.00	0.23	5.37%
	3	-	2466.49	2665.58	0.00	0.22	8.07%	2964.06	3436.15	0.00	0.39	15.93%
		+	7024.92	7225.70	0.00	0.21	2.86%	7435.82	7951.09	0.00	0.25	6.93%
		-	5944.06	6625.35	0.00	2.06	11.46%	6430.98	7740.53	0.00	4.31	20.36%
		+	13802.36	14602.14	0.00	1.93	5.79%	14326.88	15792.94	0.00	7.73	10.23%
20	3	-	3145.54	3292.93	0.00	0.43	4.69%	3542.42	4301.27	0.00	0.88	21.42%
		+	10756.72	10918.31	0.00	0.66	1.50%	11058.58	11804.55	0.00	2.32	6.75%
	6	-	7196.83	7709.87	0.00	9.60	7.13%	7544.74	8994.14	0.98	127.61	19.21%
		+	19687.36	20410.65	0.00	8.69	3.67%	20132.57	21853.02	0.03	145.77	8.55%
		-	3488.61	3703.82	0.00	0.91	6.17%	4066.86	4840.78	0.19	124.36	19.03%
		+	12299.81	12541.06	0.00	1.02	1.96%	12650.32	13574.11	0.29	126.75	7.30%
50	3	-	4203.41	4397.15	0.00	2.15	4.61%	5097.13	6135.14	3.24	324.43	20.36%
		+	15178.98	15410.82	0.00	3.41	1.53%	15694.28	16707.32	1.01	431.92	6.45%

Table 2.11 – Constant demand vs. Scenario 1 demand

## 2.5 CONCLUSION

### 2.5.1 Contributions

This chapter answers the first question of our dissertation “*how to measure stability in the IRP under demand uncertainty?*” by proposing stability metrics to be used when re-optimising the IRP. Re-optimisation is considered as an approach to deal with unexpected events for two reasons. First, the literature lacks “*a posteriori*” methods in the context of IRP. Second, the parameters of the IRP themselves (time dimension, flexibility brought by the inventory) make re-optimisation a relevant approach to investigate. When re-optimising, new objectives appear, besides the cost, to define the performance of the solution. Indeed, it might not be desirable for the new solution to be radically different from the original one – in other words, the stability of the re-optimised solutions compared to the original ones needs to be ensured. To determine how to ensure this stability and due to the lack of agreed-upon definition of the concept, we carried out a literature review of the stability metrics used for components problems of the IRP, respectively, routing and inventory management, and sequencing problems such as scheduling. The stability metrics resulting from this literature review are then adapted to the IRP, their advantages and drawbacks presented, and their mathematical formulations proposed. A framework of comparison validates the mathematical formulations of these metrics as well as investigates their behaviour in relation to each other and to the initial objective function, the cost. We show that the metrics have a tight relationship to each other and are equivalent in most cases. Furthermore, we show that their impact on the cost of the solution seems to be rather small. Finally, by investigating the hardness of solving the re-optimisation models, we show that the benchmark of the literature does not reflect the complexity of solving an IRP due to the way it is generated, hence the need of proposing new benchmarks that are compatible with real-life situations. A new benchmark is proposed in the next chapter.

### 2.5.2 Perspectives

A direct extension of the work proposed in this chapter would be to propose a comparison for the whole panel of stability metrics proposed in [Chapter 2](#) for the different compatible variants of the IRP. Moreover, in this chapter, we consider that only one event occurs. A perspective would be to investigate whether it is always possible to find feasible solutions when considering that multiple events would occur during the time horizon. Finally, as the numerical experiments of this chapter are conducted on a theoretical benchmark, it would be

interesting to confront these models to real-life data and investigate whether the same conclusions hold.

Another perspective would be to confront the re-optimisation approach proposed in this chapter to robust and stochastic optimisation approaches. This would investigate further the relevance of using re-optimisation as an approach to cater for demand uncertainty. As we do not present the uncertainties of the demand as a probabilistic distribution, a comparison with robust optimisation seems appropriate. For example, we can consider a set of possible events that can occur: The robust optimisation model would propose one solution that would be feasible no matter which event happens. The re-optimisation approach under stability metrics would propose a solution for each event. A comparison can be made between the average cost of the re-optimisation solutions in relation to the cost of the robust solution.

The next two chapters will focus on handling a different source of uncertainty, namely the travelling time.

## TIME DEPENDENT INVENTORY ROUTING PROBLEM

---

When evolving in an urban logistics context, one problem that can be faced is the volatility of the travelling times between locations. In the IRP literature, this volatility is represented as a probabilistic distribution or bounded intervals that evolve around their mean values. Such a presentation of the travelling time seems appropriate, as a quick search on any GPS navigation software will give the travelling time as an interval. However, this volatility is rarely unpredictable and depend on the fluidity of the traffic conditions which are the result, in most of the cases, of deterministic parameters. Thus, this volatility can be represented in a deterministic manner by considering the travelling times as time dependent. In this chapter and the next one, we answer the second question of our dissertation “*How to incorporate the time dependent aspect in the IRP and solve it efficiently?*”.

This chapter is presented as follows: In [Section 3.1](#) we first propose a review of the IRP literature where travelling times are the main focus. However, since the time dependent IRP literature is rather sparse, we turn to pure routing problems to investigate how the time dependent aspect is handled. In [Section 3.2](#), the TD-IRP is described and four different mathematical formulations inspired by the TD-TSP and TD-VRP literature are proposed. The difference between these formulations lies in the way in which the time is discretised and in the shape of the travelling time functions used. These differences are shown through an illustrative example. [Section 3.3](#) presents a new benchmark for the TD-IRP based on benchmarks from the IRP and the TD-TSP literature. Finally, [Section 3.4](#) assesses, validates and compares the efficiency of the proposed mathematical formulations through numerical experiments conducted on the newly generated benchmark.

### 3.1 LITERATURE REVIEW

#### 3.1.1 IRP with travelling time focus

In the IRP literature, the most common variants where the travelling time is the main focus is the IRP with time windows. In this case, clients can only be served within a certain time interval. Delgado et al. (2018) propose a review of the literature for the IRP with time windows. In a recent work by Alarcon Ortega et al. (2020), the au-



thors propose a matheuristic to solve the Consistent Inventory Routing Problem with Time Windows and Split Deliveries. This variant of the IRP arises from a real-world application, namely route planning and inventory management for beer and other beverages companies. As the clients have different opening times and time windows, satisfying the overall demand can only be done by splitting the deliveries across more than one vehicle. Furthermore, the satisfaction of the clients depends on the consistency in delivery times. The matheuristic builds an initial solution by using a constructive heuristic to decide which clients must be visited for each period. Local search operators are then applied on this solution to improve its quality, and then a MIP is solved to determine the timing and the quantities. This solution goes through iterative improvements in a second phase, using an adaptive large neighbourhood search algorithm.

Another variant in the literature is the travel time-constrained IRP. In this context, the tours must be completed before a certain duration limit. This variant caters for some legislation requirements where drivers are not allowed to drive for longer than a certain duration in order to avoid traffic accidents. Lefever et al. (2021) present a Bender's decomposition algorithm to propose robust solutions where the travelling times evolve in symmetric and bounded intervals around their mean values. Another work is proposed by Coelho et al. (2020) in a Multi-Attribute Inventory Routing Problem context, which is the integration of the Multi-Depot IRP and the travel-time constrained IRP. In this paper, the authors propose a hybrid exact algorithm to solve the problem combining Mixed Integer Programming (MIP) and Variable Neighbourhood Search schemes. Extensive experimental results prove the efficiency of the hybridation process, as it accelerates the resolution with respect to a branch-and-cut algorithm applied to the regular MIP formulation.

Other scholars focus on the sustainability of the transportation component of the IRP. In Alkaabneh et al. (2020), the authors propose a mathematical formulation that optimises the costs due to fuel consumption, inventory holding, and greenhouse gas emissions. Greenhouse gas emissions are computed as a function of fuel consumption levels that are calculated from the vehicle speed, load and travelled distance. As the travelling time is computed by vehicle speed and travelled distance, this paper is relevant for our literature. To solve the problem efficiently, the authors propose a Bender's decomposition approach with several acceleration strategies such as valid inequalities and efficient upper bounds.

In Li et al. (2014), an original way of handling travelling time in the IRP is proposed. Instead of optimising the classic inventory and transportation costs, the authors minimise the maximum travel time among all vehicles. The problem is set for a large petroleum and petrochemical Chinese enterprise group that is responsible for the

distribution of gasoline to gas stations. The authors argue that in this context, avoiding stock out is more important than focusing on transportation cost minimisation, as running out of stock might not only be viewed as a business problem, but also a social problem by the local community. The authors propose a tabu-search algorithm to solve the problem, and propose a Lagrangian relaxation formulation to produce tight lower bounds in order to assess the efficiency of their algorithm.

In all the works cited above, the travelling time is an important parameter of the problem. Most of these works model the travelling time between two locations as a constant value, which does not take into account the volatility of the travelling time, especially in urban logistics where traffic conditions can have a huge impact. However, in works such as Dong et al. (2018), Lefever et al. (2021), and Rahimi et al. (2017), it is taken into consideration by modelling the travelling time as uncertain data. One other way to take this volatility into consideration is to consider time dependent travelling times.

To the best of our knowledge, only one paper tackles the TD-IRP. In Cho et al. (2014), the authors propose a variant of the IRP where the speed of the vehicles is time dependent. In order to model the volatility of the speed throughout the day, an artificial benchmark is generated where the day is decomposed into three main time intervals: morning rush hours, off-peak hours and evening rush hours. The speed is different from one interval to another and the authors assume that these assumptions are sufficient to mimic the traffic conditions during the day. Moreover, the authors propose a genetic algorithm to solve the problem. However, since 2014, no scholars have taken interest in the TD-IRP, thus we turn to pure routing problems to better understand how time dependent travelling times are handled.

### 3.1.2 *Time dependent routing problems*

In time dependent routing problems, the travelling time between two locations does not only depend on the departure and arrival locations but also on the time of departure. During the last decades, the literature of time dependent routing problems has exponentially increased. Gendreau et al. (2015) propose an extensive review of the literature. They show that the time dependent aspect is only considered for pure routing problems such as the time dependent Travelling Salesman Problem (TD-TSP) or the time dependent Vehicle Routing Problem (TD-VRP). The paper concludes that time dependent problems are harder to solve than their basic counterparts and that although the literature is substantial, it is still recent, thus the need for new efficient approaches. The remainder of this section focuses only on work published subsequently to the review by Gendreau et al. (2015).

As time dependent routing problems are hard to solve, most of the recent work on the TD-VRP and TD-TSP consists in proposing new efficient algorithms for their different variants. New exact algorithms are proposed to solve time dependent routing problems using the most common approaches such as integer linear programming (Arigliano et al., 2019; Hansknecht et al., 2018; Montero et al., 2017; Sun et al., 2018), dynamic programming (Lera-Romero et al., 2020) and constraint programming (Melgarejo et al., 2015). The authors of Minh Vu et al. (2018) propose a novel approach based on the dynamic discretisation discovery framework that, instead of generating a time-expanded network in a static fashion, does so in a dynamic and iterative manner. The results show that the algorithm outperforms those of the literature and that it is robust with respect to all instance parameters, particularly the degree of travel time variability. However, although the performances of exact approaches are rapidly increasing, solving large-sized problems is still a computational challenge. Therefore, scholars propose algorithms based on local search procedures to solve such instances, such as adaptive large neighbourhood search (Franceschetti et al., 2017; Pan et al., 2021; Rincon-Garcia et al., 2020), ant colony algorithm (Deng et al., 2018; Liu et al., 2020), tabu search (Ban, 2019), variable neighbourhood search (Lu et al., 2020), or genetic algorithms such as the Non-dominated Sorting Genetic Algorithm (NSGA-II) (Zhao et al., 2019).

The other part of the time dependent literature focuses on generating time dependent travelling time functions. Malandraki et al. (1992) are the first to propose an artificial model where the travel time are represented as a step function of time. The shortcoming of such a representation is that the First In First Out (FIFO) property, i.e. if a vehicle leaves at time  $t \geq t'$  it arrives later than if it left at  $t'$ , does not hold. To cater for this problem, the authors propose to allow vehicles to wait at nodes. Ichoua et al. (2003) propose another solution to overcome the satisfaction of the FIFO property by considering artificial travel speeds as a step function of time instead. This yields a travelling time function that is step-wise continuous. As there are no discontinuities in the travelling time function, the FIFO property is always satisfied.

The first to propose travel time functions based on real data of the city of Berlin from 1988 to 1996 are Fleischmann et al. (2004). The travelling time functions are constant step-wise, just as in Malandraki et al. (1992). In order to cater for the FIFO property requirements, the authors propose an algorithm to smooth the function and transform it into a linear step-wise function, just as in Ichoua et al. (2003).

Since then, many scholars proposed new artificial and real-life based travelling time functions based on the models of Ichoua et al. (2003) and Fleischmann et al. (2004). The most recent work in this area is proposed by Rifki et al. (2020), where the authors propose a new real-

life benchmark for routing problems based on the traffic conditions of the city of Lyon in France, using a dynamic microscopic simulator of traffic flow. The purpose of their study is to show the impact of space granularity, i.e. the number of sensors deployed to monitor the traffic flow, and time granularity, i.e. the number and length of time steps, on the quality of the solutions for pick-up and delivery optimal tours.

Table 3.1 summarises the time dependent literature showing the problems solved, the solving approaches and the type of data used of the papers cited above.

This rich time dependent routing literature provides ideas on how to model the TD-IRP, that will be exploited throughout this chapter by proposing four different mathematical formulations. Moreover, it provides benchmarks generated from real-life data to validate and investigate the efficiency of these formulations.

### 3.2 PROBLEM DESCRIPTION AND MATHEMATICAL FORMULATIONS

The TD-IRP is an extension of the IRP on its transportation component, where the travelling time between two locations does not only depend on the departure and arrival locations, but on the time of departure as well. In this chapter, we consider that a period represents a day of the week. Each day is discretised into small time intervals for which the travelling time between two locations are different from one time interval to another. These time intervals are called time steps. Finally, we consider that all tours start at the beginning of the period. This assumption may seem counterproductive in the case of TD-IRP, since leaving later may reduce the cost of the tour. Note however that in real-life situations, the working hours of the drivers are generally fixed beforehand. In such a case, starting at a different time than the beginning of the period would amount to adding a waiting time at the depot.

Let  $\mathcal{G}' = (\mathcal{V}, \mathcal{A})$  be a directed graph where  $(i, j) \in \mathcal{A}$  is an arc linking vertices  $i$  and  $j \in \mathcal{V}$ .

$\mathcal{M}$  is a set of time steps where  $m \in \mathcal{M}$  represents the index of the time step and  $L$  its duration.  $|\mathcal{M}|$  represents the number of time intervals into which a period  $p \in \mathcal{H}$  is discretised.  $\mathcal{T}$  represents the same thing but when period  $p \in \mathcal{H}$  is discretised to its finest granularity where  $|\mathcal{T}| = |\mathcal{M}| \times L$ . For example, if a period  $p$  is a day decomposed into 12 time intervals of one hour,  $|\mathcal{M}|$  would be equal to 12, and if we suppose that the finest granularity is in seconds,  $L = 3600$  and  $|\mathcal{T}| = 43200$ .

Let  $f(i, j, m)$  be a step-wise constant travelling time function, that represents the duration of travelling through arc  $(i, j) \in \mathcal{A}$  when leaving  $i \in \mathcal{V}$  at time step  $m \in \mathcal{M}$ . The issue with such functions is that

	Problem			Approaches			Data	
	TSP	VRP	IRP	Exact	Heuristics	Type	Artificial	Real-life
Malandraki et al. (1992)	✓	✓		✓		ILP	✓	
Ichoua et al. (2003)		✓			✓	TS	✓	
Fleischmann et al. (2004)		✓			✓	CH		✓
Cho et al. (2014)			✓		✓	NSGA-II	✓	
Melgarejo et al. (2015)	✓			✓		CP		✓
Franceschetti et al. (2017)		✓			✓	ALNS	✓	
Montero et al. (2017)	✓			✓		ILP	✓	
Deng et al. (2018)		✓			✓	ACO	✓	
Hansknecht et al. (2018)	✓			✓		ILP	✓	
Minh Vu et al. (2018)	✓			✓		DDD	✓	
Sun et al. (2018)	✓			✓		ILP	✓	
Arigliano et al. (2019)	✓			✓		ILP	✓	
Ban (2019)	✓				✓	TS,VNS	✓	✓
Zhao et al. (2019)		✓			✓	NSGA-II	✓	
Lera-Romero et al. (2020)	✓			✓		DP	✓	
Liu et al. (2020)		✓			✓	ACO	✓	
Lu et al. (2020)		✓			✓	VNS	✓	
Pan et al. (2021)		✓			✓	ALNS	✓	
Rincon-Garcia et al. (2020)		✓			✓	ALNS	✓	
Rifki et al. (2020)	✓			✓		DP		✓

Table 3.1 – A summary of the time dependent routing literature. ILP = Integer Linear Programming; CP = Constraint Programming; DP = Dynamic Programming; TS =

Tabu Search; ACO = Ant Colony Optimisation; ALNS = Adaptive Large Neighbourhood Search; VNS = Variable Neighbourhood Search; NSGA-II = Non-dominated Sorting Genetic Algorithm; DDD = Dynamic Discretisation Discovery; CH = Constructive heuristics.

they do not ensure the First In First Out Property (FIFO). If the FIFO property is not ensured, it means that a vehicle  $A$  is able to arrive earlier than a vehicle  $B$  by departing later. This is not realistic when vehicles  $A$  and  $B$  are travelling on the same arc with the same speed. One way to cater for this issue is to transform the function  $f$  into a linear step-wise function. Let  $f^{\text{FIFO}}(i, j, t)$  be a step-wise linear travelling time function, that represent the duration of travelling through arc  $(i, j) \in \mathcal{A}$  when leaving  $i \in \mathcal{V}$  at time  $t \in \mathcal{T}$ .

### 3.2.1 First In First Out property

Let  $f'(i, j, t)$  be a travelling time function such that:  $i, j \in \mathcal{V}$ ,  $t \in \mathcal{T}$  is the time of departure from  $i$  to  $j$  and  $|\mathcal{T}|$  is the length of a period. Function  $f'$  enforces the FIFO property only and only if:

$$t' + f'(i, j, t') \geq t + f'(i, j, t) \quad \forall (i, j) \in \mathcal{A}, \forall t, t' \in \mathcal{T} \text{ where } t' \geq t$$

In other words, a travelling time function that enforces the FIFO property ensures that if leaving  $i$  to  $j$  at  $t$ , it is impossible to arrive later than when leaving  $i$  to  $j$  at  $t'$  when  $t'$  is later than  $t$ . Such property is not satisfied for the travelling time function  $f$  which is a constant piece-wise function.

Therefore, to ensure that  $f$  enforces the FIFO property, it needs to be transformed into a linear step-wise function  $f^{\text{FIFO}}$ . In this dissertation, we use the procedure presented in Fleischmann et al. (2004).

Let  $t_m$  be the time interval of time step  $m$ , where  $t_m = [t_m^{\min}, t_{m+1}^{\min}[$  and  $t_m^{\min}$  represents the beginning of interval  $t_m$ .

When there is an increasing discontinuity between time step  $m$  and its successor  $m + 1$ , i.e.  $f(i, j, m) < f(i, j, m + 1)$ , the FIFO property is always satisfied since for all  $t' \in t_{m+1}$  and  $t \in t_m$ :  $t' > t$  and  $f(i, j, m + 1) > f(i, j, m)$ . Therefore  $t' + f(i, j, \lceil \frac{t'}{L} \rceil) > t + f(i, j, \lceil \frac{t}{L} \rceil)$ . However, when a decreasing discontinuity occurs, an interval exists in  $t_m$  for which the FIFO property is not satisfied. This non-FIFO interval is denoted by  $t_m^{\overline{\text{FIFO}}}$  where  $t_m^{\overline{\text{FIFO}}} \subseteq t_m$ . We demonstrate this through an example of a constant piece-wise travelling time function, where  $\mathcal{M} = 3$  and  $L = 5$ , presented in Figure 3.1. We also show how to define the interval  $t_m^{\overline{\text{FIFO}}}$  and transform the travelling time function  $f$ , into one that enforces the FIFO property  $f^{\text{FIFO}}$ .

Following the constant step-wise travelling time function  $f$  presented in Figure 3.1a, Table 3.2 shows whether the FIFO property is ensured, depending on the time of departure between two successive time steps.

We can see from the table that between time steps 2 and 3, there exists a moment where the FIFO property is no longer satisfied, as by leaving from  $i$  at 6, we arrive later than if we left at 8. In this case,

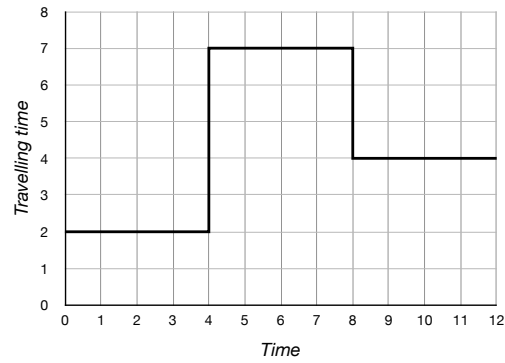

(a) constant piece-wise function  $f$

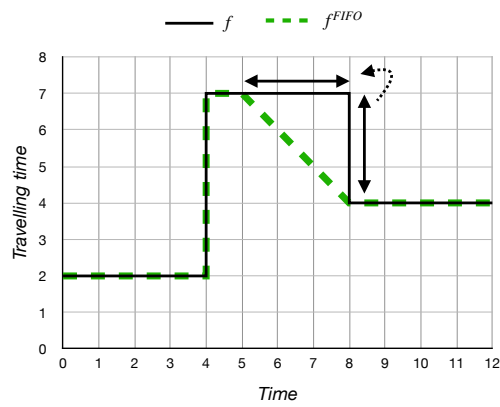

(b) linear piece-wise function  $f^{FIFO}$

Figure 3.1 – Transformation of  $f$  into  $f^{FIFO}$

$m$	$t^{\text{departure}}$	$f(i, j, t^{\text{departure}})$	$t^{\text{arrival}}$	FIFO
1	0	2	2	✓
2	4	7	11	✓
2	4	7	11	✓
3	8	4	12	✓
2	6	7	13	x
3	8	4	12	x

Table 3.2 – An example of the FIFO satisfaction property depending on the departure time between two time steps

the interval  $t_m^{\overline{\text{FIFO}}}$  for which the function no longer satisfies the FIFO property is defined as

$$t_m^{\overline{\text{FIFO}}} = [\max \{t_m^{\min}, t_{m+1}^{\min} - (f(i, j, m) - f(i, j, m + 1))\}; t_{m+1}^{\min}]$$

In the case of the example,  $t_2^{\overline{\text{FIFO}}} = [\max\{4, 8 - (7 - 4)\}; 8] = [5; 8]$ .

Now that the interval  $t_m^{\overline{\text{FIFO}}}$  is identified, the constant piece-wise function  $f$  is transformed into a linear piece-wise function such as

$$f^{\text{FIFO}}(i, j, t) = \min \left\{ f(i, j, m = \left\lfloor \frac{t}{L} \right\rfloor), \min_{n \in \mathcal{N}} n(t) \right\} \quad \forall t \in \mathcal{T}, \forall (i, j) \in \mathcal{A}$$

$\mathcal{N}$  is a set of linear functions  $n$  that are added for every decreasing discontinuity. The full procedure for the FIFO transformation is described in [Algorithm 3.1](#).

---

**Algorithm 3.1:** FIFO transformation procedure

---

1 [b]

- 1: **input:** a constant piece-wise travelling time function  $f$ , an arc  $(i, j) \in \mathcal{A}$  and an empty set of linear functions  $\mathcal{N}$
  - 2: **for**  $m \in \mathcal{M} = \{1, 2, \dots, |M| - 1\}$  **do**
  - 3:   **if**  $f(i, j, m) > f(i, j, m + 1)$  **then**
  - 4:     create a linear function  $n$  such that
 
$$n(t) = \begin{cases} -t + f(i, j, t_{m+1}^{\min}) + t_{m+1}^{\min} & \forall t < t_{m+1}^{\min} \\ +\infty & \forall t \geq t_{m+1}^{\min} \end{cases}$$
  - 5:     add  $n$  to  $\mathcal{N}$
  - 6:   **end if**
  - 7: **end for**
  - 8: **return**  $f$  and  $\mathcal{N}$
- 

It is worth noting that our transformation is made only for time steps where a decreasing discontinuity happens just as in Melgarejo et al. (2015), as opposed to Fleischmann et al. (2004), where the function is smoothed for each increasing or decreasing discontinuity. This choice was made to ensure that the FIFO property is enforced, but at the same time stay as faithful as possible to the benchmark. Moreover, we believe that this makes the travelling time functions more realistic as when a congestion appears, the travelling time does not evolve in a smooth manner but evolves in a sharp manner.

### 3.2.2 Four mathematical formulations

In the following, four mathematical formulations are proposed for the TD-IRP. These formulations are based on different discretisations of the time as well as the use of travelling time functions of different



forms (constant and linear piece-wise). Formulations 1 and 2 will be described in details, whereas for the third and fourth formulations, only the differences to the first one are shown.

### 3.2.2.1 TD-IRP formulation 1: discretisation in seconds

The first formulation represents the most natural way of modelling the problem by discretising the length of a period to its finest granularity, the seconds. The travelling time between two locations in this formulation is computed with the linear piece-wise function  $f^{\text{FIFO}}$ .

To mathematically formulate the TD-IRP, the model presented in Section 1.1.1 is extended with variables  $x_{ij}^{pt}$ . They are binary variables that are equal to 1 if  $(i, j) \in \mathcal{A}$  is travelled in period  $p$  and the departure time from  $i$  to  $j$  is  $t \in \mathcal{T}$ , 0 otherwise. These variables represent the same information as variables  $x_{ij}^p$ , only with a different granularity since if  $|\mathcal{T}| = 1$ ,  $x_{ij}^p = x_{ij}^{pt}$ .

---

#### TD-IRP: discretisation in seconds

---

$$\min \quad \text{obj}_1^{\text{TD-IRP}} = c \sum_{(i,j) \in \mathcal{A}} \sum_{p \in \mathcal{H}} \sum_{t \in \mathcal{T}} f^{\text{FIFO}}(i, j, t) \times x_{ij}^{pt} + \sum_{i \in \mathcal{V}} \sum_{p \in \mathcal{H}'} h_i \times I_i^p$$

s.t (1) to (6) and (8) to (12)

$$\sum_{j \in \mathcal{V}'} x_{ij}^p = y_i^p \quad \forall i \in \mathcal{V}, \forall p \in \mathcal{H} \quad (31)$$

$$\sum_{j \in \mathcal{V}'} x_{ji}^p = y_i^p \quad \forall i \in \mathcal{V}, \forall p \in \mathcal{H} \quad (32)$$

$$\sum_{t \in \mathcal{T}} x_{ij}^{pt} = x_{ij}^p \quad \forall (i, j) \in \mathcal{A}, \forall p \in \mathcal{H} \quad (33)$$

$$\sum_{j \in \mathcal{V}'} x_{0j}^{p0} = y_0^p \quad \forall p \in \mathcal{H} \quad (34)$$

$$\sum_{v_k \in P \setminus \{v_n\}} \sum_{t_{v_k} \in T} x_{v_k, v_{k+1}}^{p, t_{v_k}} \leq |P| - 2 \quad \forall [P, T] \text{ infeasible}, p \in \mathcal{H} \quad (35)$$

$$x_{ij}^{pt} \in \{0, 1\} \quad \forall (i, j) \in \mathcal{A}, t \in \mathcal{T}, \forall p \in \mathcal{H} \quad (36)$$

---

The objective of the first formulation of the TD-IRP modifies the objective of the IRP in the transportation component, where the transportation cost is no longer computed from the euclidean distances, but using the linear piece-wise function  $f^{\text{FIFO}}$ . Moreover, it replaces constraints (7) by constraints (31) and (32) which state that we arrive and leave a visited location only once. This difference is due to the fact that in the TD-IRP,  $\mathcal{G}'$  is a directed graph.

The time dependent aspect is ensured by constraints (33) to (36). Constraints (33) link variables  $x_{ij}^{pt}$  with variables  $x_{ij}^p$  and state that if an arc  $(i, j) \in \mathcal{A}$  is travelled in period  $p$ , it leaves  $i$  at one and only

one point in time  $t \in \mathcal{T}$ . Constraints (34) state that routing starts at the beginning of period  $p \in \mathcal{H}$ , i.e.  $t = 0$ . Constraints (35) eliminate time dependent infeasible paths, where  $[P, T]$  is a time dependent infeasible path. Finally, constraints (36) enforce integrality and non-negativity conditions on the TD-IRP variables.

The definition of a time dependent infeasible path is presented below, as described in Miranda-Bront et al. (2010).

#### *Time dependent infeasible path*

Let  $P = \langle v_1, \dots, v_{k-1}, v_k, v_{k+1}, \dots, v_n \rangle$  where  $v_k \in \mathcal{V}'$  and  $v_1 = v_n = 0$  the supplier. Let  $T = \langle t_{v_1}, \dots, t_{v_{k-1}}, t_{v_k}, t_{v_{k+1}}, \dots, t_{v_{n-1}} \rangle$  be a set of departure times. A time dependent path  $[P, T]$  is a combination of  $P$  and  $T$  where  $T$  represents the departure times of  $v_k \in P \setminus \{v_n\}$ .

Let  $t'_{v_k}$  be the possible departure time of  $v_k$ ,  $s_{v_k}$  the service time at location  $v_k \in P$ :

$$\begin{aligned} - t'_{v_k} &= \begin{cases} 0 + s_{v_k} & \forall v_k \in \{v_1, v_n\} \\ t'_{v_{k-1}} + f^{\text{FIFO}}(v_{k-1}, v_k, t'_{v_{k-1}}) + s_{v_k} & \forall v_k \in P \setminus \{v_n, v_1\} \end{cases} \\ - [P, T] \text{ is infeasible} &\iff \exists v_k \in P : t_{v_k} \neq t'_{v_k} \end{aligned}$$

#### *Variables generation*

One drawback of this formulation is the number of variables  $\#x_{ij}^{pt} = |\mathcal{V}|^2 \times |\mathcal{H}| \times |\mathcal{M}| \times L$ . This number can be very large when  $|\mathcal{V}|$ ,  $|\mathcal{H}|$ ,  $|\mathcal{M}|$  and  $L$  are big. However, as shown with constraints (34), the supplier always leave at the beginning of the period, i.e.  $t = 0$ . With this assumption, and since we might need to visit all the clients for one period in order to satisfy their demand, a solution would be to compute an upper bound for the total time needed to visit all clients at once. This can be done by any heuristic that solves the TD-TSP.

Let  $\mathcal{T}'$  be the resulting reduced set of time-units in which the tour must be completed and  $\mathcal{M}'$  its equivalent in time steps, where  $|\mathcal{M}'| = \left\lceil \frac{|\mathcal{T}'|}{L} \right\rceil$ . Moreover, the travelling times between two locations  $i, j \in \mathcal{V}$  are not of the order of the second and can be quite large. Therefore, there exist a set of times for which it is impossible to reach any client at that time. Thus, number of variables can be largely reduced by generating the variable only by considering locations that are time dependent reachable. Algorithm 3.2 generates all the reachable vertices before the upper bound  $|\mathcal{T}'|$ . Algorithm 3.3 removes all the vertices that are not in a route that leads to the supplier. Finally, Algorithm 3.4 generates a set of variables  $\mathcal{A}^p \subseteq \mathcal{A}$  which represents the time dependent arcs that are possible to go through.

---

**Algorithm 3.2:** Possible time dependent vertices generation

---

```
1: Input: a step-wise linear function  $f^{\text{FIFO}}$ , a set of locations  $\mathcal{V}$ , a set
   of periods  $\mathcal{H}$ , a tour upper bound  $\mathcal{T}'$  and an empty set of
   possible vertices  $\mathcal{V}^{\text{possible}}$  where  $v_i^t \in \mathcal{V}^{\text{possible}}$ ,  $i \in \mathcal{V}$  and  $t \in \mathcal{T}$  is
   the departure time from vertex  $i$ 
2: let  $vPred_i^t$  be a set of predecessors of vertex  $v_i^t$ 
3:  $\mathcal{V}^{\text{possible}} \leftarrow v_0^0$ 
4: while  $\mathcal{V}^{\text{possible}}$  is not empty do
5:   let  $\mathcal{V}_{\text{toDelete}}^{\text{possible}}$  and  $\mathcal{V}_{\text{toAdd}}^{\text{possible}}$  be, respectively, sets of vertices to
   delete and to add
6:   for  $v_i^t \in \mathcal{V}^{\text{possible}}$  do
7:      $\mathcal{V}_{\text{toDelete}}^{\text{possible}} \leftarrow v_i^t$ 
8:     if  $i \neq 0$  or  $t = 0$  then
9:       for  $j \in \mathcal{V}$  do
10:        if  $j \neq i$  then
11:          if  $t' = t + f^{\text{FIFO}}(i, j, t) + s_j \leq |\mathcal{T}'|$  then
12:             $vPred_j^{t'} \leftarrow v_i^t$ 
13:             $\mathcal{V}_{\text{toAdd}}^{\text{possible}} \leftarrow v_j^{t'}$ 
14:          end if
15:        end if
16:      end for
17:    end if
18:  end for
19:  delete  $\mathcal{V}_{\text{toDelete}}^{\text{possible}}$  from  $\mathcal{V}^{\text{possible}}$ 
20:  add  $\mathcal{V}_{\text{toAdd}}^{\text{possible}}$  to  $\mathcal{V}^{\text{possible}}$ 
21:  clear  $\mathcal{V}_{\text{toDelete}}^{\text{possible}}$  and  $\mathcal{V}_{\text{toAdd}}^{\text{possible}}$ 
22: end while
23: return  $\mathcal{V}^{\text{possible}}$ 
```

---

---

**Algorithm 3.3:** Graph cleaning procedure

---

```
1: Input: a set of possible vertices  $\mathcal{V}^{\text{possible}}$ 
2: let  $\mathcal{V}^{\text{noSucc}}$  be a set of vertices without a successor
3: while  $\mathcal{V}^{\text{noSucc}}$  is not empty do
4:   remove  $\mathcal{V}^{\text{noSucc}}$  from  $\mathcal{V}^{\text{possible}}$ 
5:   clear  $\mathcal{V}^{\text{noSucc}}$ 
6:   for  $v_i^t \in \mathcal{V}^{\text{possible}}$  do
7:     for  $v_j^{t'} \in vPred_j^{t'}$  do
8:       mark that  $v_j^{t'}$  has a successor
9:     end for
10:  end for
11:  for  $v_i^t \in \mathcal{V}^{\text{possible}}$  do
12:    if  $v_i^t$  does not have a successor then
13:       $\mathcal{V}^{\text{noSucc}} \leftarrow v_i^t$ 
14:      for  $v_j^{t'} \in vPred_j^{t'}$  do
15:        mark  $v_j^{t'}$  with no successor
16:      end for
17:    end if
18:  end for
19: end while
20: return  $\mathcal{V}^{\text{possible}}$ 
```

---

---

**Algorithm 3.4:** Variables generation

---

```
1: Input: A set of possible vertices  $\mathcal{V}^{\text{possible}}$  and an empty set of
   variables  $\mathcal{A}^p$ 
2: for  $p \in \mathcal{H}$  do
3:   for  $v_i^t \in \mathcal{V}^{\text{possible}}$  do
4:     for  $v_j^{t'} \in vPred_i^{t'}$  do
5:        $\mathcal{A}^p \leftarrow x_{ij}^{pt}$ 
6:     end for
7:   end for
8: end for
9: return  $\mathcal{A}^p$ 
```

---

### 3.2.2.2 TD-IRP formulation 2: breakpoints discretisation

Formulation 2 discretises the time into a new number of time steps based on a discretisation into breakpoints, that are points at which the slope of function  $f^{\text{FIFO}}$  changes. It is a re-adaptation of the time dependent ready function formulation proposed by Sun et al. (2018) and used in the paper of Pan et al. (2021) for a TD-TSP with time windows.

The first thing to do for the breakpoints formulation is to decompose the duration of the period into a new set of time steps  $\mathcal{M}^{\text{new}}$ , where the time steps  $m' \in \mathcal{M}^{\text{new}}$  have different duration and are defined in the interval  $[w_{ij}^{m'}, w_{ij}^{m'+1}[$  where  $w_{ij}^{m'}$  represents the beginning of the time step and  $w_{ij}^{m'+1}$  the end of the time step. This decomposition is done on the linear step-wise function  $f^{\text{FIFO}}$ .

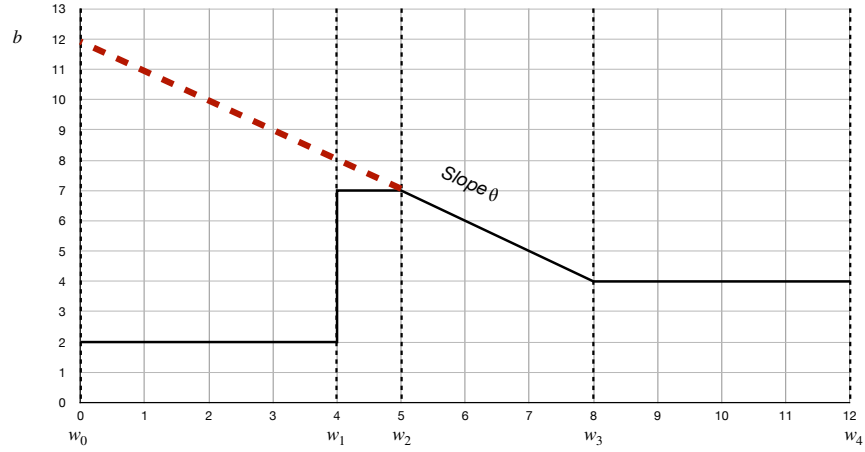

Figure 3.2 – Decomposing the period into a new set of time steps  $\mathcal{M}^{\text{new}}$

Figure 3.2 shows the new set of time steps  $\mathcal{M}^{\text{new}}$  defined for the example presented in Figure 3.1b.  $\theta_{ij}$  represents the slope which, in our case, is equal to  $-1$  for each time step  $m' \in \mathcal{M}^{\text{new}}$  where the function is linear and  $0$  when the function is constant.  $b_{ij}$  represents the intersection of the function with the y-axis. For time steps  $m' \in \mathcal{M}^{\text{new}}$  where the function is linear,  $b_{ij} = w_{ij}^{m'} + f(i, j, w_{ij}^{m'})$  whereas for time steps where it is constant,  $b_{ij} = f(i, j, w_{ij}^{m'})$ .

The travelling time can be computed such that:

$$f^{\text{FIFO}}(i, j, t) = \theta_{ij} \times t + b_{ij}$$

In order to propose a new model based on breakpoints, three variables are introduced:  $dt_{ij}^{pm}$  a continuous variable that represent the departure time from  $i$  to  $j$  if the departure time of  $i \in \mathcal{V}$  to  $j \in \mathcal{V}$  for period  $p \in \mathcal{H}$  is in time step  $m'$  and  $0$  otherwise;  $dtt_i^p$ , a continuous variable that represents the departure time from  $i$  in period  $p$  if location  $i \in \mathcal{V}$  is visited in period  $p \in \mathcal{H}$  and  $0$  otherwise;  $at^p$ , a

continuous variable that represents the arrival time at the supplier for each period  $p \in \mathcal{H}$  and equals to 0 if no deliveries are performed. Moreover, the index  $m$  of variables  $x_{ij}^{pm}$  is replaced by  $m' \in \mathcal{M}^{\text{new}}$ .

---

### TD-IRP: time dependent ready function formulation

---

$$\min \quad \text{obj} = c \sum_{p \in \mathcal{H}} at^p + \sum_{i \in \mathcal{V}} \sum_{p \in \mathcal{H}'} h_i \times I_i^p$$

s.t (1) to (6) and (8) to (12)

$$\sum_{m' \in \mathcal{M}^{\text{new}}} x_{ij}^{pm'} = x_{ij}^p \quad \forall (i, j) \in \mathcal{A}, \forall p \in \mathcal{H} \quad (37)$$

$$\sum_{j \in \mathcal{V}} \sum_{m' \in \mathcal{M}^{\text{new}}} dt_{ij}^{pm'} = dtt_i^p \quad \forall i \in \mathcal{V}, \forall p \in \mathcal{H} \quad (38)$$

$$dt_{ij}^{pm'} \geq w_{ij}^{m'} \times x_{ij}^{pm'} \quad \forall (i, j) \in \mathcal{A}, \forall m' \in \mathcal{M}^{\text{new}}, \forall p \in \mathcal{H} \quad (39)$$

$$dt_{ij}^{pm'} \leq (w_{ij}^{m'+1} - 1) x_{ij}^{pm'} \quad \forall (i, j) \in \mathcal{A}, \forall m' \in \mathcal{M}^{\text{new}}, \forall p \in \mathcal{H} \quad (40)$$

$$\sum_{j \in \mathcal{V}'} x_{0j}^{p0} = y_0^p \quad \forall p \in \mathcal{H} \quad (41)$$

$$\sum_{j \in \mathcal{V}'} dt_{0j}^{pm'} = 0 \quad j \in \mathcal{V}, m' \in \mathcal{M}^{\text{new}}, \forall p \in \mathcal{H} \quad (42)$$

$$\sum_{j \in \mathcal{V}'} dtt_0^p = 0 \quad \forall p \in \mathcal{H} \quad (43)$$

$$at^p = \sum_{i \in \mathcal{V}} \sum_{m' \in \mathcal{M}^{\text{new}}} \{dt_{i0}^{pm'} + f(i, 0, dt_{i0}^{pm'})\} x_{i0}^{pm'} \quad \forall p \in \mathcal{H} \quad (44)$$

$$dtt_i^p \geq \{dt_{ij}^{pm'} + f(i, j, dt_{ij}^{pm'}) + s_j\} x_{ij}^{pm'} \quad \forall i \in \mathcal{V}', \forall j \in \mathcal{V}, \forall m' \in \mathcal{M}^{\text{new}}, \forall p \in \mathcal{H} \quad (45)$$

$$dt_{ij}^{pm'} \in [0, |\mathcal{M}'| \times L] \quad \forall (i, j) \in \mathcal{A}, m' \in \mathcal{M}^{\text{new}}, \forall p \in \mathcal{H} \quad (46)$$

$$dtt_i^p \in [0, \mathcal{T}'] \quad \forall i \in \mathcal{V}, \forall p \in \mathcal{H} \quad (47)$$

$$at^p \in [0, \mathcal{T}'] \quad \forall p \in \mathcal{H} \quad (48)$$

$$x_{ij}^{pm'} \in \{0, 1\} \quad \forall (i, j) \in \mathcal{A}, m' \in \mathcal{M}^{\text{new}}, \forall p \in \mathcal{H} \quad (49)$$

---

In addition to Constraints (1) to (6) and (8) to (12) the model is extended with the following constraints: constraints (37) link variables  $x_{ij}^p$  to variables  $x_{ij}^{pm'}$ . Constraints (38) link variables  $dt_{ij}^{pm'}$  to variables  $dtt_i^p$ . Constraints (39) and (40) state that if we leave  $i$  to  $j$  in time step  $m'$ , then the departure time from  $i$  to  $j$  is bounded with the lower and upper bounds of the definition interval of time step  $m'$ . Constraints (41) to (43) state that for each period  $p$ , the departure time from the supplier is 0. Constraints (44) computes the arrival time at the supplier for each period  $p$ . Constraints (45) state the departure

time from each client. Finally, constraints (46) to (49) enforce integrality and non-negativity conditions on the newly defined variables.

Note that constraints (44) and (45) are non-linear constraints. Therefore, they need to be linearised. Constraints (44) then become:

$$at^p = \sum_{i \in \mathcal{V}} \sum_{m' \in \mathcal{M}^{\text{new}}} \{(1 + \theta_{ij})dt_{i0}^{pm'} + b_{ij} \times x_{i0}^{pm'}\} \quad \forall p \in \mathcal{H} \quad (50)$$

Constraints (45) become:

$$M - s_j \geq dt_{ij}^{pm'}(1 + \theta_{ij}) + (b_{ij} + M)x_{ij}^{pm'} - dt_{ij}^p \\ \forall i \in \mathcal{V}', \forall j \in \mathcal{V}, \forall m' \in \mathcal{M}^{\text{new}}, \forall p \in \mathcal{H}, M = \mathcal{T}' \quad (51)$$

### 3.2.2.3 TD-IRP formulation 3: time step discretisation

The difference between the third and the first formulations (discretisation in seconds) resides in the discretisation of the period. In this case, the period is discretised to the set of time steps  $\mathcal{M}$ . Therefore, variables  $x_{ij}^{pt}$  are replaced by variables  $x_{ij}^{pm}$ . Variables  $x_{ij}^{pm}$  are generated in the same manner as in formulation 1, using Algorithms 3.2 to 3.4 where line 5 of Algorithm 3.4 is replaced by:  $\mathcal{A}^p \leftarrow x_{ij}^{p[\frac{t}{L}]}$ .

Now that the period is discretised into time steps  $\mathcal{M}$ , it is no longer possible to use  $f^{\text{FIFO}}$  to compute the objective. The objective is therefore replaced by

$$obj_2^{\text{TD-IRP}} = c \sum_{(i,j) \in \mathcal{A}} \sum_{p \in \mathcal{H}} \sum_{m \in \mathcal{M}} f(i, j, m) \times x_{ij}^{pm} + \sum_{i \in \mathcal{V}} \sum_{p \in \mathcal{H}'} h_i \times I_i^p$$

This formulation will provide solutions that satisfy the FIFO property. However, differences between the objective values of formulations 1 or 2 and formulation 3 are to be expected since they are computed with two different functions. These differences are to be expected only when the optimal tour of formulation 1 or 2 goes through arc  $(i, j) \in \mathcal{A}$  at a time  $t \in \mathcal{T}$  where  $f^{\text{FIFO}}(i, j, t) < f(i, j, [\frac{t}{L}])$ . In other words, if the departure time  $t$  belongs to the interval of time step  $[\frac{t}{L}]$  which is transformed into a decreasing slope in order to satisfy the FIFO property (Time interval [5,8] in Figure 3.1b).

All other constraints remain the same as well as the definition of a time dependent feasible path.

It is worth noting that the variables as well as the time dependent infeasible paths are defined using the step-wise linear function  $f^{\text{FIFO}}$ .

### 3.2.2.4 TD-IRP formulation 4: Time step discretisation with waiting times

This formulation discretises a period to the set of time steps  $\mathcal{M}$  just like formulation 3. Formulation 4 however only uses the constant step-wise travelling time function  $f$  by allowing waiting times at client's locations. Variables  $x_{ij}^{pm}$  are used for this formulation as

well but cannot be generated with Algorithms 3.2 to 3.4 since the addition of waiting times implies a new decision on when to leave from a client's location to another. However, in order to limit these waiting times, only the variables with index  $m$  smaller than the upper bound (expressed in time steps)  $\mathcal{M}'$  are generated.

The objective and constraints are the same as the ones of formulation 3. However, since the waiting times are allowed at the clients and since these waiting times are not explicitly represented in the model (with a variable), they are not taken into consideration in the cost of the solution. Therefore, the transportation component of the objective function will only minimise the cost related to the moving time of the vehicle and cannot minimise the earliest arrival time at the supplier (moving + waiting times).

Moreover, the introduction of waiting times changes the definition of a time dependent infeasible path as follows:

#### *Time dependent infeasible path with waiting times*

Let  $T$  now be a set of departure time steps such that

$T = \langle m_{v_1}, \dots, m_{v_{k-1}}, m_{v_k}, m_{v_{k+1}}, \dots, m_{v_{n-1}} \rangle$ ,  $t'_{v_k}$  the earliest departure time at location  $v_k \in P$  and  $t_{m_k}^{\min}$  the beginning of time step  $m_k$ :

$$\begin{aligned} - t'_{v_k} &= \begin{cases} 0 + s_{v_k} & \forall v_k \in \{v_1, v_n\} \\ \max\{t'_{v_{k-1}} + f(v_{k-1}, v_k, \lfloor \frac{t'_{v_{k-1}}}{L} \rfloor) + s_{v_k}, t_{m_k}^{\min}\} & \forall k \in P \setminus \{v_n, v_1\} \end{cases} \\ - [P, T] \text{ is infeasible} &\iff \exists v_k \in P : t'_{v_k} \notin [t_{m_k}^{\min}, t_{m_{k+1}}^{\min}[ \end{aligned}$$

A synthesis of the differences between the four formulations is presented in Table 3.3. It shows the level of discretisation for each formulation  $k$ , whether waiting times (WT) are allowed or not, the function used for the objective *obj*, the function used for the generation of the variables, the function used for the elimination of the time dependent infeasible paths and finally the nature of the optimised objective.

$k$	Discretisation	WT	Functions used			Objective
			<i>obj</i>	$\mathcal{A}_p$	$[P, T]$	
1	$\mathcal{T}$	x	$f^{\text{FIFO}}$	$f^{\text{FIFO}}$	$f^{\text{FIFO}}$	Arrival time
2	$\mathcal{M}^{\text{new}}$	x	$f^{\text{FIFO}}$	x	x	Arrival time
3	$\mathcal{M}$	x	$f$	$f^{\text{FIFO}}$	$f^{\text{FIFO}}$	Arrival time
4	$\mathcal{M}$	✓	$f$	x	$f$	Travelling time

Table 3.3 – A synthesis of the properties of the four mathematical formulations



### 3.2.3 An illustrative example

Let us consider an example of the TD-IRP where the network is composed of a supplier and three clients  $\mathcal{V} = \{0, 1, 2, 3\}$ , a time horizon  $|\mathcal{H}| = 3$  and a vehicle capacity  $C = 20$ . Each period  $p \in \mathcal{H}$  is decomposed into  $|\mathcal{M}| = 3$  time steps with a length  $L = 10$  time units. Table 3.4 and Figure 3.3 present all the data related to instance  $w$ . The columns of Table 3.4 represent, respectively, the indices  $i$  of the supplier/clients, their initial inventory  $I_i^0$  and maximum inventory  $I_i^{\max}$ , the production rate  $R^p$  of the supplier, the demand  $D_i^p$  of the clients and finally the holding costs. Figure 3.3 illustrates the travelling times between each couple of locations for every time step. The service time for all clients is assumed to be equal to 1. The figure shows for example that the travelling time between 0 and 1 is of  $f(0, 1, 1) = 8$  for the first time step, 12 for the second and 10 for the third.

$i$	$I_i^0$	$I_i^{\max}$	$R^p$			$D_i^p$			$h_i$
			$p = 1$	$p = 2$	$p = 3$	$p = 1$	$p = 2$	$p = 3$	
0	30	$+\infty$	30	30	30	-	-	-	0.1
1	15	20	-	-	-	8	12	10	0.15
2	10	25	-	-	-	15	11	19	0.18
3	5	10	-	-	-	8	4	3	0.13

Table 3.4 – A representation of the data for the example instance

The solutions of the example regarding the four proposed formulations are presented Table 3.5, Figure 3.4, Figure 3.5 and Figure 3.6. Table 3.5 presents the inventory levels at the end of each period of each location  $I_i^p$  and the quantities  $q_i^p$  sent from the supplier to each client  $i$  for the whole time horizon. These values are the same for all four formulations. Figure 3.4, Figure 3.5 and Figure 3.6 show, respectively, the sequence of the routing component through a Gantt chart for formulation 1 and 2, 3 and 4. The blue parts in Figure 3.5 and Figure 3.6 show the solution of formulation 1 re-computed with the constant step-wise function  $f$  instead of the linear step-wise function  $f^{\text{FIFO}}$  and without waiting times for formulation 4.

As we can see from Table 3.5, clients 2 and 3 are replenished in period  $p = 1$ , all clients are replenished in period  $p = 2$  and clients 1 and 2 are visited in period  $p = 3$ .

Figure 3.4, Figure 3.5 and Figure 3.6 show that for:

$p = 1$  All four formulations, the vehicle leaves the supplier, visits client 2 and then client 3 in the first time step. In the beginning of the second time step, it leaves client 3 to return to the supplier at time 18 without waiting at any node for formulation 4.

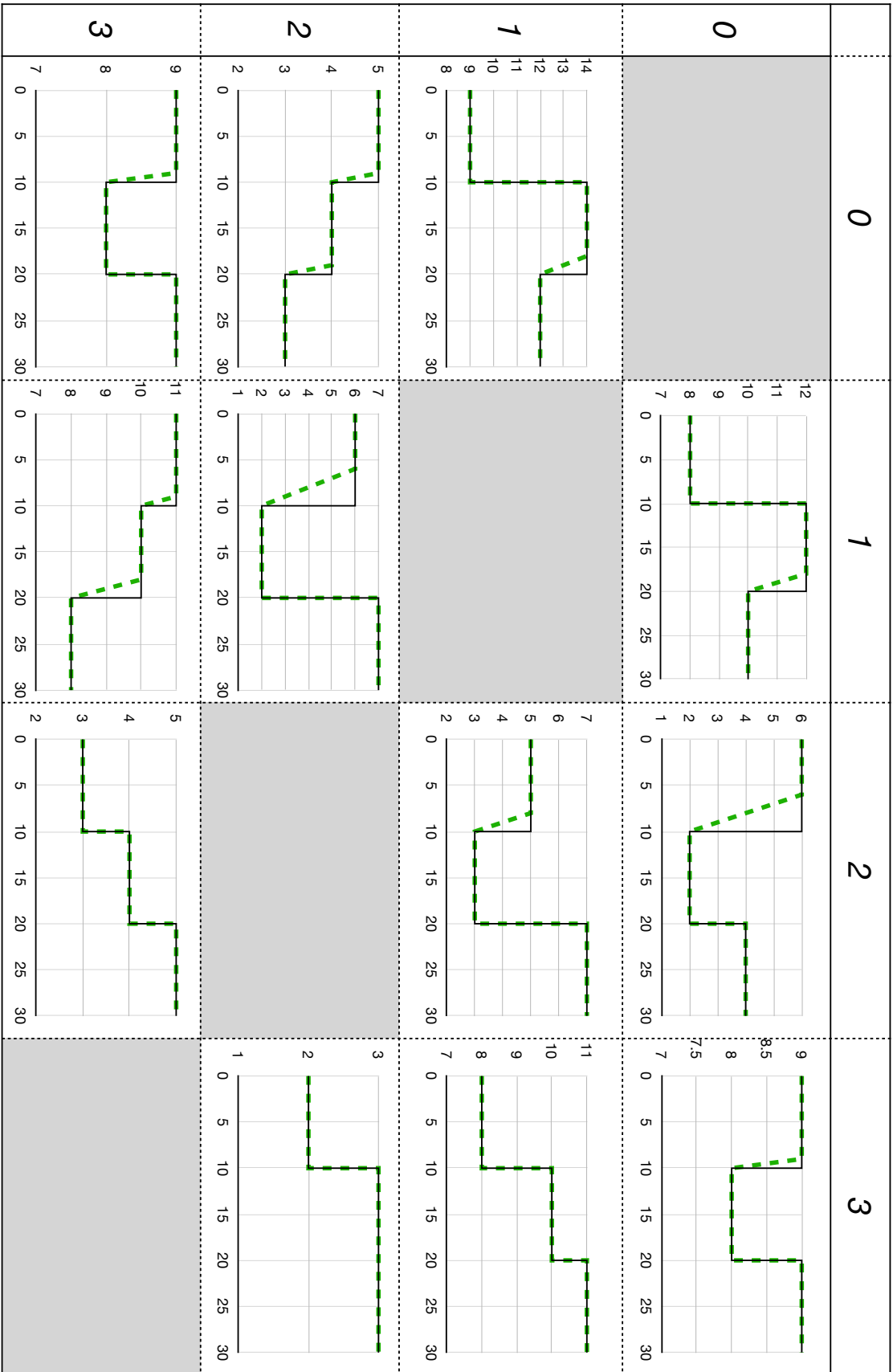

Figure 3.3 – A representation of the travelling time functions between the locations of the network

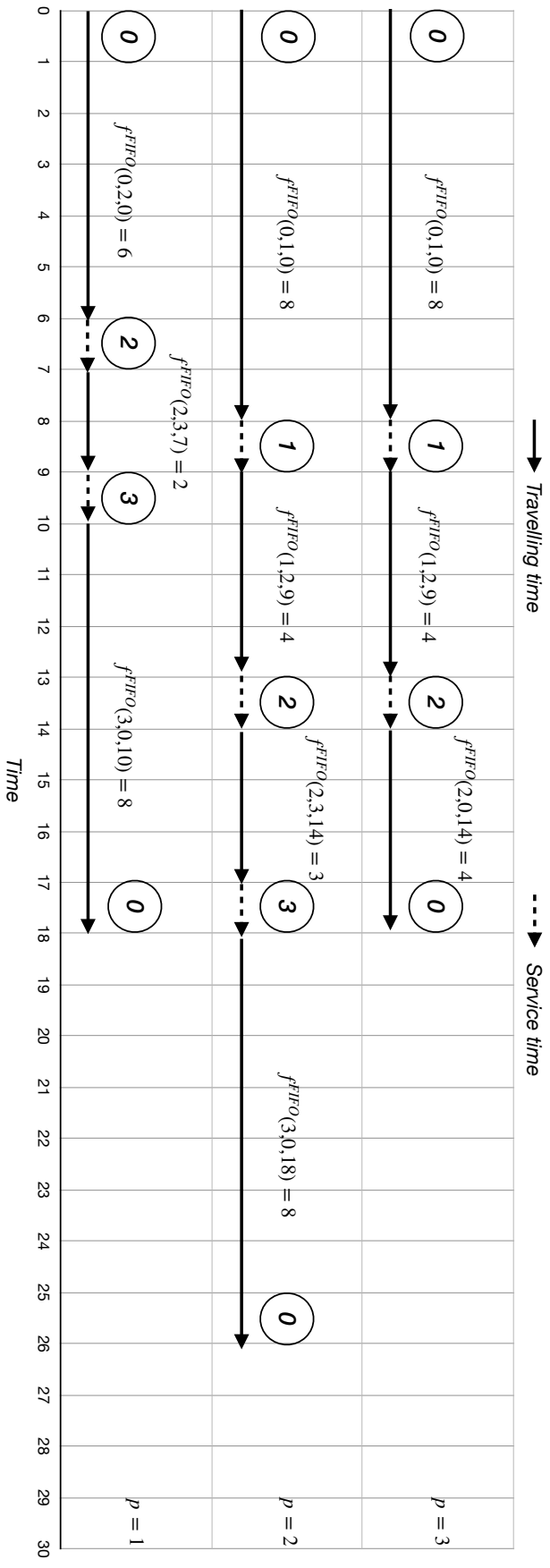

Figure 3.4 – The example's transportation sequence for formulation 1 and 2

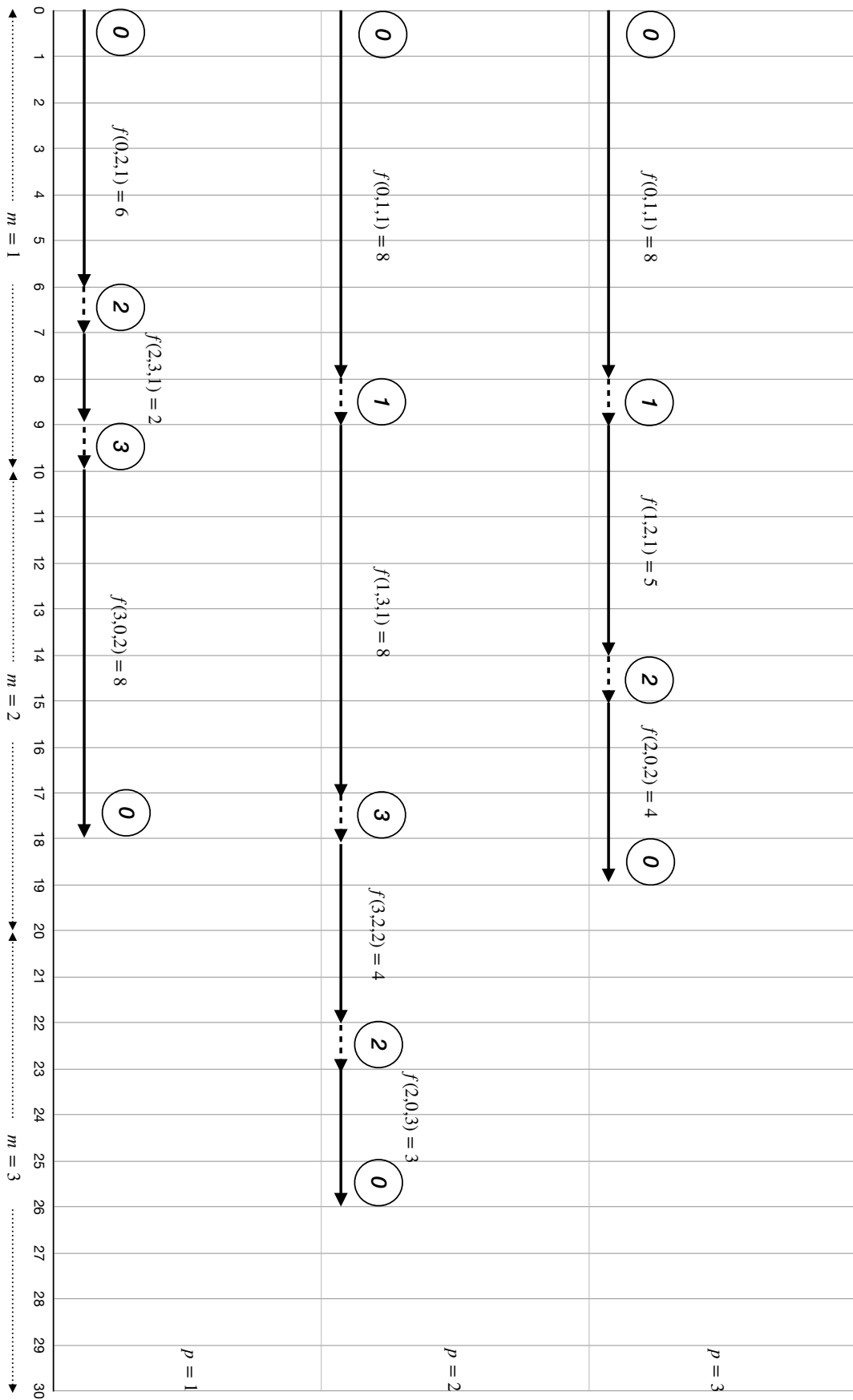

Figure 3.5 – The example's transportation sequence for formulation 3

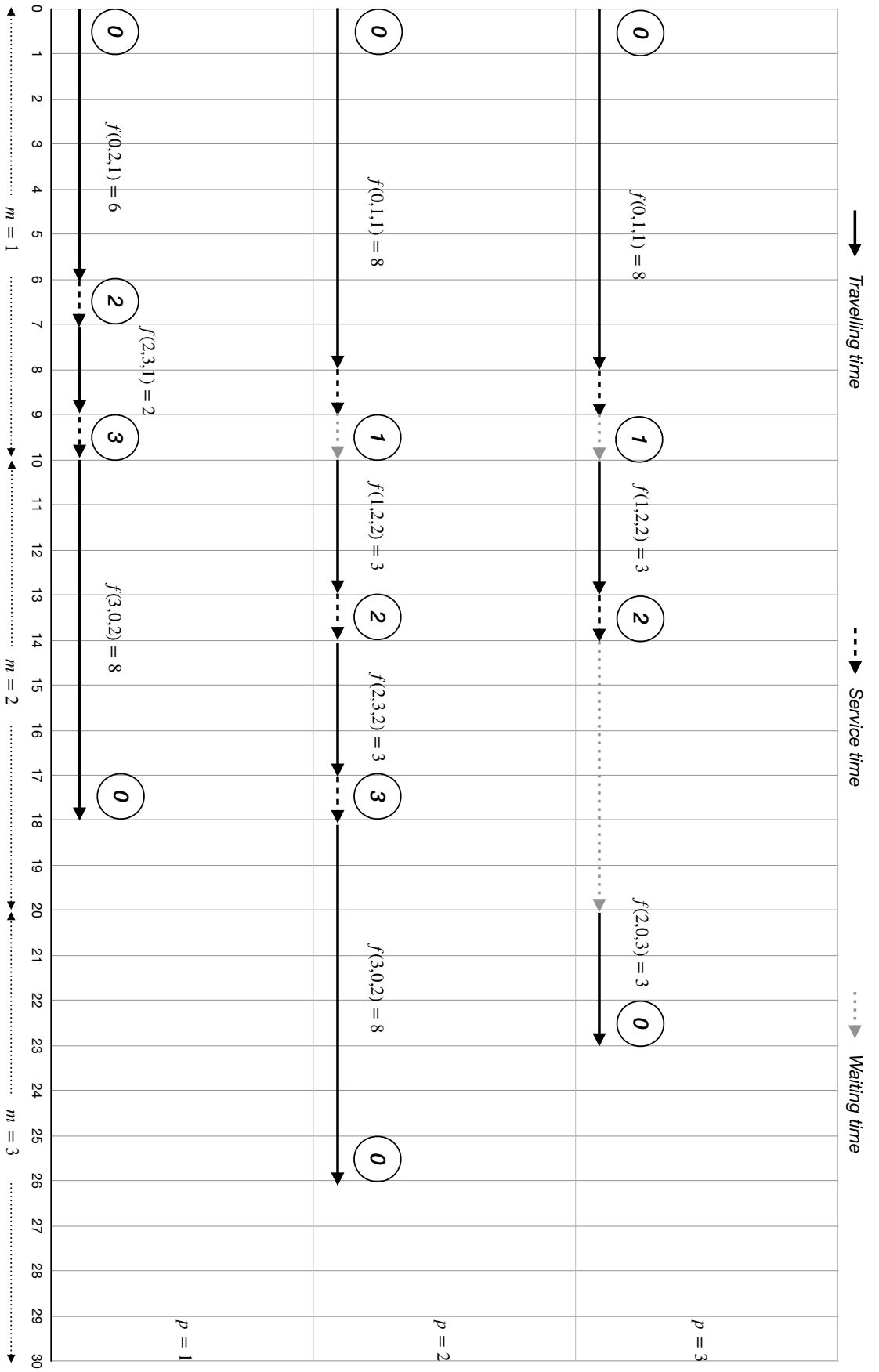

Figure 3.6 – The example's transportation sequence for formulation 4

$i$	$I_i^p$			$q_i^p$		
	$p = 1$	$p = 2$	$p = 3$	$p = 1$	$p = 2$	$p = 3$
0	40	50	60			
1	7	8	0	0	13	2
2	10	1	0	15	2	18
3	2	3	0	5	5	0

Table 3.5 – Values of variables  $I_i^p$  and  $q_i^p$  for the example's optimal solution

$p = 2$  Formulation 1, 2 and 4 follow the same sequence by visiting client 1, 3 and 2. However, the difference between the two is that for formulation 1, the departure time from client 1 is 9, whereas for formulation 4, there is a waiting time until 10, i.e.  $m = 2$ , to depart. The arrival time at the supplier is 26. Indeed, as we can see from the first formulation's solution re-computed with  $f$  (chart in blue), by not waiting, the arrival time is 27. Moreover, since waiting times are not included in the objective function of formulation 4, by waiting, the total cost is  $c \times (8 + 3 + 3 + 8) = 22$  instead of  $c \times (8 + 5 + 3 + 8) = 24$  for the solution of formulation 1 re-computed with  $f$ .

For formulation 3 on the other hand, the positions of clients 2 and 3 in the sequence are inverted. Indeed, by inverting the positions of these two clients, the cost of solution is  $c \times (8 + 8 + 4 + 3) = 23$  instead of the 24 of the solution of formulation 1 re-computed with  $f$ . Moreover, the arrival time is 26, just as in the solution of formulation 1.

$p = 3$  Clients 1 and 2 are visited following the same sequence in all four formulations. However, in formulation 4, waiting time occurs at both client 1 and client 2. Although the solution proposed by formulation 1 when re-computed in  $f$  arrives earlier than the solution of formulation 4, the cost of solutions is larger as it is equal to  $c \times (8 + 4 + 4) = 16$  instead of the  $c \times (8 + 3 + 3) = 12$  of the solution of formulation 4.

### 3.3 A NEW BENCHMARK FOR THE TD-IRP

Since the TD-IRP has only been studied once in the IRP literature (Cho et al., 2014), benchmarks for the TD-IRP are nonexistent. In this section, we thus propose a new benchmark for the TD-IRP, combining an IRP benchmark proposed in Archetti et al. (2007) with a TD-TSP benchmark proposed in Rifki et al. (2020). Both benchmarks are first modified and adapted to better fit our needs, the main objective being of mimicking real-life conditions as closely as possible.

### 3.3.1 Inventory management data

The inventory-related data of the benchmark is generated using the benchmark proposed in Archetti et al. (2007). Although this benchmark is the most commonly used in the IRP literature, it is generated following rather strong assumptions:

- the demand of the clients is constant for the whole horizon;
- the vehicle's capacity is large enough to replenish all clients in one period;
- initial inventories are such that no replenishment is needed for the first period of the horizon;
- the holding cost of some clients is inferior than the one of the supplier.

These assumptions are rarely met in real-life instances. Furthermore, they lead to optimal solutions in which the clients are all replenished in a single period. Such structures rarely reflect real-life solutions, especially in urban logistics where the size of vehicles is small and the inventory capacities at the delivery points are not large enough to ensure demand satisfaction for a large period of time.

Therefore, modifications are performed on a subset of the instances proposed, in order to provide a more realistic benchmark. The generation of the new values is done for instances with  $|\mathcal{H}| = \{3, 6\}$ , a number of clients  $|\mathcal{V}'_{|\mathcal{H}|=3}| = \{5, 10, 15, 20, 25, 30\}$  when  $|\mathcal{H}| = 3$  and  $|\mathcal{V}'_{|\mathcal{H}|=6}| = \{5, 10, 15, 20\}$  when  $|\mathcal{H}| = 6$ . For each combination of these parameters, 5 different instances are generated, which yields a total of 50 instances. Algorithm 3.5 presents the generation process.

The demand of the new benchmark is no longer constant, but varies from one period to another by  $\pm[-0.25, 0.25]$  of the initial value  $D_i^{\text{old}}$ . The value of 0.25 in this case is arbitrary. The production rate of the supplier is set such that it is possible to meet the demand of all the clients for each period. The inventory capacity of the clients can cover the demand for up to two periods on average whereas the one of the supplier is unlimited. The initial inventory levels of the clients follow a uniform distribution over the set  $\{0, 0.25, 0.50, 0.75, 1\} \times I_i^{\text{max}}$ . The initial inventory of the supplier can cover the inventory capacity of all the clients once. The vehicle capacity is set such that it can only cover up to 90% of the demand average for one period. Finally, we assume that the holding cost of the supplier should be inferior to the one of the clients and set it to  $2/3$  of the smallest holding cost of the clients. This assumption is made from the realistic hypothesis that the supplier is able to handle its inventory more efficiently than its clients. Furthermore, clients in this case are situated in urban areas, where the holding costs tend to be higher.

---

**Algorithm 3.5:** Inventory management component data generation

---

1: **input:** an instance from the benchmark of Archetti et al. (2007)  
2: **for**  $i \in \mathcal{V}'$  **do**  
3:   **for**  $p \in \mathcal{H}$  **do**  
4:     generate a random  $\delta \in [-0.25, 0.25]$   
5:      $D_i^p = \lfloor D_i^{\text{old}} \times (1 + \delta) \rfloor$   
6:   **end for**  
7:    $I_i^{\text{max}} = \frac{2}{|\mathcal{H}|} \sum_{p \in \mathcal{H}} D_i^p$   
8:   generate a random number  $\rho \in [0, 1[$   
9:    $I_i^0 = \begin{cases} 0 & \text{if } \rho \in [0, 0.2[ \\ I_i^{\text{max}} \times 0.25 & \text{if } \rho \in [0.2, 0.4[ \\ I_i^{\text{max}} \times 0.5 & \text{if } \rho \in [0.4, 0.6[ \\ I_i^{\text{max}} \times 0.75 & \text{if } \rho \in [0.6, 0.8[ \\ I_i^{\text{max}} & \text{if } \rho \in [0.8, 1[ \end{cases}$   
10:  
11: **end for**  
12:  $C = \frac{0.9}{|\mathcal{H}| \times |\mathcal{V}'|} \sum_{i \in \mathcal{V}'} \sum_{p \in \mathcal{H}} D_i^p$   
13:  $h_0 = \frac{2}{3} \min_{i \in \mathcal{V}'} h_i$   
14:  $R^p = \frac{1.25}{|\mathcal{H}| \times |\mathcal{V}'|} \sum_{i \in \mathcal{V}'} \sum_{p \in \mathcal{H}} D_i^p$   
15:  $I_0^0 = \sum_{i \in \mathcal{V}'} I_i^{\text{max}}$

---



### 3.3.2 Time dependent travelling time functions

In the benchmark of Archetti et al. (2007), the distance travelled between two locations is defined by the euclidean distance. In our benchmark, this data is disregarded and replaced by time dependent travelling time functions.

Producing time dependent functions for routing problems is a productive field in transportation literature. A variety of functions exist in the literature (Rifki et al., 2020): some are artificial while others are based on real traffic data. In the previously cited paper of Rifki et al. (2020) in Section 3.1.1, the authors propose a benchmark based on the traffic conditions of the city of Lyon in France, using a dynamic microscopic simulator of traffic flow. Based on data collected from sensors placed in the axes of the city, a time dependent travelling time function is defined for a time interval of 12 hours and is decomposed into time steps. For each time step, a consistent spatio-temporal mean formulation is used to compute the travelling time for each segment of the network. Afterwards, the shortest path is computed between each two different locations for each time step. The benchmark yields a set of constant piece-wise travelling time functions between each two different locations with different time granularity/time steps  $|\mathcal{M}| = \{1, 12, 30, 60, 120\}$  of respective lengths  $L = \{720, 60, 24, 12, 6\}$  minutes, for 250 instances in total. An example of these travelling time functions between two random locations is presented in Figure 3.7. It shows the travelling time function, as explained in Figure 3.1a, but with different time steps  $|\mathcal{M}|$ . The figure shows that the travelling time functions are highly volatile which can seem unrealistic. However, it is not unreasonable in urban transportation since the travelling times between two locations are already small and a bit of traffic congestion can indeed double or triple the travelling time.

For all instances described in Section 3.3.1, a set of locations are randomly picked from Rifki et al. (2020)'s benchmark and matched to each location from Archetti et al. (2007)'s benchmark. The time dependent travelling time functions corresponding to this set of locations are added to the instance.

### 3.3.3 Travel-time constraint

In Section 3.2.2.1 it is stated that since the departure time is always the beginning of the period, computing an upper bound will restrict the number of variables generated. Moreover, Section 3.2.2.4 states that travelling cost incurs only when the vehicle is moving from one location to another. Therefore, since waiting at nodes does not incur any cost, it is unrestricted and can occur as long as it is profitable to wait. However, this can yield solutions where the waiting time is

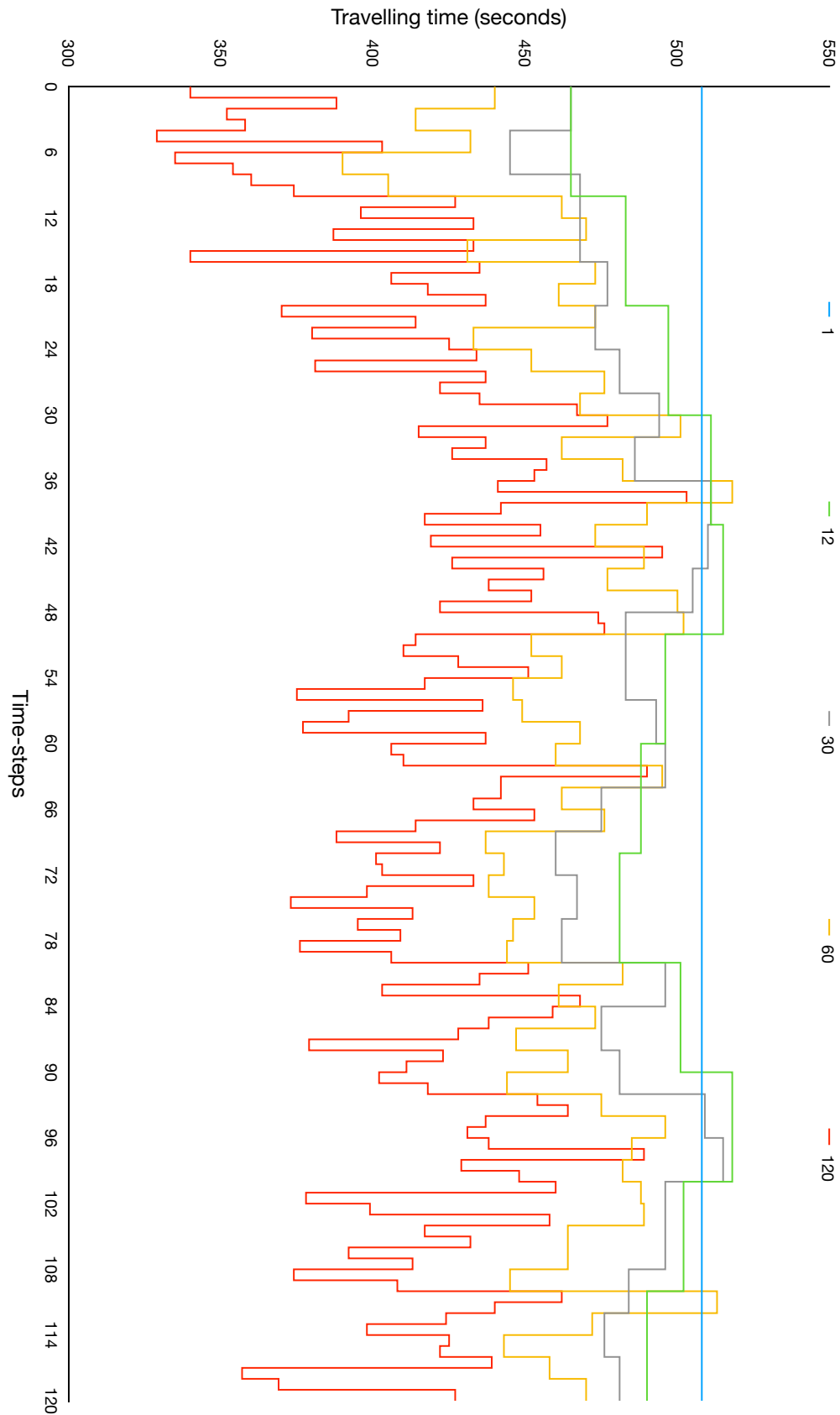

Figure 3.7 – A travelling time function between two random locations for  $|\mathcal{M}| = \{1, 12, 30, 60, 120\}$

extremely high in comparison to the travelling time. This is unrealistic as one cannot ask a driver to park and wait for hours in order to optimise the cost. In order to restrict this waiting time, we propose to limit the total duration of a tour with travel time constraints.

Since our benchmark is set in an urban distribution context, and since a day is long enough to visit a high number of clients in one period, we propose travel time constraints that allow the visit of all clients in one period as long as the capacity of the vehicle is not exceeded, while ensuring the FIFO property and at the same time restrict the waiting times. To generate such values, a TD-TSP is solved through an iterated local search heuristic presented in Algorithm 3.6, using  $f^{\text{FIFO}}$ . The objective value of the TD-TSP will be the travel-time constraint for which the tour must be completed, thus minimising the waiting at nodes. Note that any heuristic that can solve the TD-TSP can provide a value for  $\mathcal{T}'$ .

---

**Algorithm 3.6:** TD-TSP: ILS

---

```

1: input:  $f^{\text{FIFO}}$ , a set of locations to visit and empty values  $|\mathcal{T}'|$  and  $|\mathcal{M}'|$ 
2: while A time limit is not exceeded and the local optimal is not reached do
3:   generate a random sequence and set its tour length to  $|\mathcal{T}'|$  if it is better or is still empty
4:   apply local search operations such as movements and swaps
5:   Movements:
6:   for  $k, k' \in V, k \neq k'$  do
7:     slide the vertex at the  $k^{\text{th}}$  position and slide it to position  $k'$  leaving the rest of the sequence unchanged
8:   end for
9:   Swaps:
10:  for  $k, k' \in V, k \neq k'$  do
11:    swap the vertex at the  $k^{\text{th}}$  position with the vertex of position  $k'$  and vice versa
12:  end for
13:  set  $|\mathcal{T}'|$  to the obtained solution if it is better
14: end while
15:  $|\mathcal{M}'| = \lceil \frac{|\mathcal{T}'|}{L} \rceil$ 
16: return  $|\mathcal{T}'|$  and  $|\mathcal{M}'|$ 

```

---

The final benchmark is readily available at <https://github.com/faycalt/TDIRP>.

### 3.4 COMPARISON OF THE FOUR FORMULATIONS

In this section, numerical experiments are conducted in order to compare the performances of the four mathematical formulations presented in Section 3.2.2. The performances are compared in general, as well as regarding the objective of the earliest arrival time at the supplier, as both formulation 3 and 4 provide solutions that are not necessarily optimal in that regard as seen in Figure 3.4, Figure 3.5 and Figure 3.6. This will be done by re-computing the tours of formulations 3 and 4 with the step-wise linear function  $f^{\text{FIFO}}$  and without waiting times for formulation 4.

All experiments are conducted on a CPU Intel Xeon E5-1620 v3 @3.5Ghz with 64GB RAM in a Java-Gurobi environment. Gurobi 9.0.2 is used as a solver and the subtours as well as the time dependent infeasible paths elimination constraints are added dynamically through a branch-and-cut procedure using the *lazyConstraints* parameter, the default number of threads and a time-limit of 3600 seconds. The experiments are conducted on the newly generated benchmark. They are conducted on a set of 100 instances where 5 different instances are solved for each combination of parameters  $|\mathcal{V}'| = \{5, 10, 15\}$ ,  $|\mathcal{H}| = \{3, 6\}$ ,  $|\mathcal{M}| = \{12, 30, 60, 120\}$  except for combination  $\{|\mathcal{V}'| = 15, |\mathcal{H}| = 6\}$ .

Table 3.6 shows the results of these numerical experiments. For each formulation  $k$ ,  $|\mathcal{A}_k|$  is the average number of time dependent variables,  $g^{\text{RL}_k}$  is the average gap between the solution found and the best lower bound and  $\text{CPU}_k$  is the execution time, in seconds. Finally,  $gAT_k^{k'}$  are the average gaps between the arrival times of formulation  $k'$  in comparison to formulation  $k$ . "x" means that no solution has been found within the given time limit. Note that for formulation 2,  $|\mathcal{A}|$  represent only the number of boolean variables, as the other routing variables  $dt$ ,  $dtt$  and  $at$  are continuous. Moreover, we do not provide the gap between formulations 3 and 4 in relation to formulation 2, as formulation 2 is optimal in terms of arrival time at the supplier, just as formulation 1.

The first observation is that the differences between the optimal solutions of the four formulations reside only in the sequence in which the clients are visited for each period, as the variables related to inventory management, i.e. whether a client is visited and the quantity sent for each client at each period, are always optimal. Indeed, in formulations 1, 2 and 3, the objective function of the transportation component is the same, i.e. minimising the arrival time at the supplier, but formulated with different discretisations of the time and computed with a different function for formulation 3. However, the transportation component of the objective function for formulation 4 is not only formulated in a different manner, but minimises only the total travelling time of the vehicle without the idle time resulting

$ V $	$ H $	$ M $	$ A_1 $	$g_1^{\text{RL}}$	CPU <sub>1</sub>	$ A_2 $	$g_2^{\text{RL}}$	CPU <sub>2</sub>	$ A_3 $	$g_3^{\text{RL}}$	CPU <sub>3</sub>	$ A_4 $	$g_4^{\text{RL}}$	CPU <sub>4</sub>	$gAT_1^2$	$gAT_1^3$	$gAT_1^4$	$gAT_3^4$
5	3	12	1617	0	3.99	90	0	1.63	90	0	0	90	0	0.08	4.89	0	4.89	0
5	6	12	3681.6	0	8.53	421.2	0	15.64	180	0	0.04	180	0	0.04	5.12	0	5.12	0
5	3	30	1617	0	3.99	210.6	0	7.10	210.6	0	0.08	180	0	0.01	0	0	1.11	1.11
5	6	30	3681.6	0	8.53	687.6	0	482.11	421.2	0	0.08	360	0	0.08	0	0	0.39	0.39
5	3	60	1617	0	3.99	343.8	0	20.79	343.8	0	0.04	270	0	0.03	0	0	0.36	0.36
5	6	60	4033.2	0	63.81	1365.6	19.63	3379.994	687.6	0	0.32	1008	0	0.29	0	0	0.72	0.72
5	3	120	2068.2	0	3.11	678	0	63.33	678	0	0.07	504	0	0.06	0	0	2.20	2.20
5	6	120	4329.6	0	45.40	180	4.17	1022.54	1365.6	0	0.48	1008	0	0.29	0	0	1.27	1.27
10	3	12	42.10 <sup>4</sup>	X	X	X	X	X	332	0	0.04	462	0	0.07	X	X	X	1.49
10	6	12	80.10 <sup>4</sup>	X	X	X	X	X	662	0	0.174	792	0	0.26	X	X	X	0.88
10	3	30	41.10 <sup>4</sup>	X	X	X	X	X	721	0	0.71	990	0	0.65	X	X	X	3.44
10	6	30	84.10 <sup>4</sup>	X	X	X	X	X	1444	0	669.29	1980	0	16.74	X	X	X	2.15
10	3	60	40.10 <sup>4</sup>	X	X	X	X	X	1294	0	4.97	1650	0	1.23	X	X	X	5.19
10	6	60	85.10 <sup>4</sup>	X	X	X	X	X	2622	1.02	3504	3300	0	42.17	X	X	X	2.24
10	3	120	43.10 <sup>4</sup>	X	X	X	X	X	2210	0	100.77	3168	0	23.51	X	X	X	5.16
10	6	120	80.10 <sup>4</sup>	X	X	X	X	X	4252	2.50	3600	6204	0.38	909.06	X	X	X	4.51
15	3	12	2.10 <sup>6</sup>	X	X	X	X	X	1384	0	10.35	1440	0	0.36	X	X	X	2.29
15	3	30	2.10 <sup>6</sup>	X	X	X	X	X	2273	0.39	767.09	2880	0	6.758	X	X	X	2.19
15	3	60	19.10 <sup>5</sup>	X	X	X	X	X	4177	1.65	3503	5040	0	55.48	X	X	X	3.71
15	3	120	19.10 <sup>5</sup>	X	X	X	X	X	7625	3.65	3600	9504	0	1853.07	X	X	X	4.79

Table 3.6 – Results of the comparison of the four proposed formulations

from service or waiting time. Therefore, it is interesting to see that this re-formulation does not have an impact on the optimality of the inventory management decisions.

The results show that although the number of the time dependent variable of formulation 1 is reduced using Algorithms 3.2 to 3.4, it is still very high (up to 2 million variables for instances with 15 clients). Formulation 1 cannot solve instances with  $|\mathcal{V}'| > 5$  as no feasible solution is found within the time limit. We can also see that for some instances with  $|\mathcal{H}| = 6$  and  $|\mathcal{M}| = 60$ , it is more difficult to solve than with 120 time steps. Moreover, we can see that even for instances with 5 clients and 6 periods, the computation time is high when the number of time steps is higher than formulations 3 and 4.

Similarly to formulation 1, formulation 2 cannot solve instances with  $|\mathcal{V}'| > 5$  as no feasible solution is found within the time limit. The same observation is confirmed for instances with  $|\mathcal{H}| = 6$  and  $|\mathcal{M}| = 60$ . Moreover, although for all the instances with  $|\mathcal{V}'| = 5$  formulation 2 is able to find the optimal solutions, for some instances, it is not able to prove the optimality of these solutions, as the gap to the best lower bound found is up to 19.64% on average for instances with  $|\mathcal{H}| = 6$  and  $|\mathcal{M}| = 30$ . Finally, the computation time is extremely higher than formulation 1. These poor performances of formulation 2 were expected, as the re-adapted formulation is based on big- $M$  constraints and was initially introduced in a time windows context. Indeed, the time windows provide bounds for  $M$  that can be efficient, which is not the case in this dissertation.

Formulation 3 is able to solve more instances optimally. However, instances with a number of clients  $|\mathcal{V}'| = 10$ , a number of periods  $|\mathcal{H}| = 6$  and a number of time steps  $|\mathcal{M}| = 120$  are not optimally solved. The same goes for instances with  $|\mathcal{V}'| = 15$  and  $|\mathcal{M}| \geq 60$ .

For instances that are optimally solved with formulation 1, the results show that formulation 3 provides optimal solutions with regards to the arrival time in 75% of the cases, whereas in the other 25%, it degrades it to a maximum of 5%.

Formulation 4 is able to solve all instances optimally apart from one instance only where  $|\mathcal{V}'| = 10$ ,  $|\mathcal{H}| = 6$  and  $|\mathcal{M}| = 120$ . Although the number of time dependent variables is higher in comparison to formulation 3, formulation 4 is more efficient as the branch-and-cut procedure performs less iterations.

For instances that are optimally solved with formulation 1, optimal solutions of formulation 4 when re-computed with  $f^{\text{FIFO}}$  degrade the arrival time to a maximum of 5%. For all other instances, as no feasible solutions are found with formulation 1, they are compared to the solutions of formulation 3. The results show the same gap of 5% between formulations 3 and 4. However, this result is to be nuanced as the arrival times of formulation 3 are not necessarily optimal.

As a result of these numerical experiments, formulation 4 will be used in order to investigate the relevance of the TD-IRP, which is one of the objectives of [Chapter 4](#). Although formulation 4 does not provide optimal solutions regarding the arrival time at the supplier, it is able to solve larger instances than the other three formulations without heavily degrading the arrival time at the supplier. In addition, in some applications, one can argue that optimising the total travelling time is more important than the arrival time.

### 3.5 CONCLUSION

#### 3.5.1 *Contributions*

This chapter tackles the TD-IRP where the travelling time between two locations depends on the time of departure and is not constant throughout the day. The literature shows that although the time dependent routing literature is quite rich, only one paper takes interest in the TD-IRP. Four mathematical formulations for the TD-IRP are proposed, based on the different models proposed in the literature for time dependent routing problems such as the TD-VRP and the TD-TSP: formulation 1 with a fine discretisation of time, formulation 2 with breakpoints discretisation, formulation 3 with a step-wise discretisation without allowing waiting times and formulation 4 with a step-wise discretisation with waiting times allowed. To validate and compare the efficiency of these mathematical formulations, numerical experiments are conducted on a new proposed benchmark inspired by benchmarks from the literature of the IRP and the TD-TSP. The results show that none of the proposed formulations degrades the quality of the inventory management component of the solution, i.e. the decision on which clients to visit and which quantity to send for each period of the time horizon, as all four formulations are optimal in this regard. Moreover, they show that the formulations where waiting times are allowed is more efficient, i.e. it is able to solve more large-sized instances than the other formulations, and even though the main drawback of this formulation is that it does not optimise the length of the tour as efficiently as the other formulations, only a small degradation is observed in the value of the objective function.

#### 3.5.2 *Perspectives*

A natural perspective of the work conducted in this chapter is to extend the comparison of the four proposed formulations to other formulations of time dependent routing problems that are used to handle variants with different parameters. Moreover, as all the formulations proposed in this chapter are under the assumption that

the departure time from the supplier is always at the beginning of the period, a future perspective would be to take advantage of the time dependent aspect by considering the departure time as a decision variable. Such a hypothesis can have a huge impact on the improvement of the cost of the time dependent solutions, as sometimes it is way more efficient to leave later in order to avoid congestion. Another perspective would be to investigate the efficiency of these formulations for the TD-IRP with time windows, as in this context, waiting at nodes can be very relevant.

The next chapter investigates the relevance of considering time dependent travelling times. Moreover, it proposes a metaheuristic to efficiently solve larger problems.





In Gendreau et al. (2015), the authors state that time dependent problems are harder to solve than their basic counterparts and that although the literature is substantial, it is still recent, thus the need for new efficient approaches. The previous chapter answered the first part of our second research question “*How to incorporate the time dependent aspect in the IRP*”. Four mathematical formulations for the TD-IRP were proposed. The results showed that the fourth formulation, i.e. a time step discretisation of the time and the use of constant step-wise travelling time functions with allowed waiting times, is the most efficient one. This chapter handles the second part of the question “*How to efficiently solve the TD-IRP?*” In this chapter, only the fourth formulation will be used.

In the following, Section 4.1 investigates the relevance of considering time dependent travelling times through a comparison between optimal time dependent solutions and constant travelling time transportation solutions re-solved in a time dependent environment. As a result of this investigation, Section 4.2 proposes a matheuristic for the TD-IRP in order to solve large-sized instances where the problem is decomposed into a problem where the clients to visit for each period are designated, first, and a TD-TSP solved second.

#### 4.1 INVESTIGATING THE RELEVANCE OF TD-IRP

In order to investigate the relevance of the TD-IRP, we compare optimal time dependent solutions to constant travelling time solutions re-solved in a time dependent environment. To that purpose, all time dependent instances, i.e. with  $|\mathcal{M}| > 1$ , are solved twice. The two phases are described in Figure 4.1. In the first phase, the instances are solved optimally. Afterwards, the solutions of instances with constant travelling time, i.e. with  $|\mathcal{M}| = 1$ , are re-solved in time dependent instances, where  $|\mathcal{M}| \in \{12, 30, 60, 120\}$ . As we can see from Figure 4.1a, by solving the problem with constant travelling time, we fix the inventory management variables  $I_i^p, q_i^p$ , which state the inventory levels and the quantities sent for each client, and the routing variables  $x_{ij}^p$  which state the clients to be visited and in which order they should be visited. Afterwards, the time steps of departure from each location are determined subsequently by solving the TD-IRP in a time dependent environment.

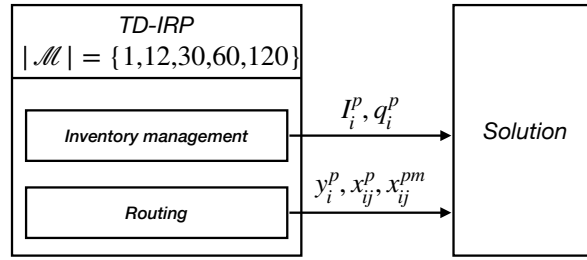

(a) Procedure for optimal TD-IRP solutions

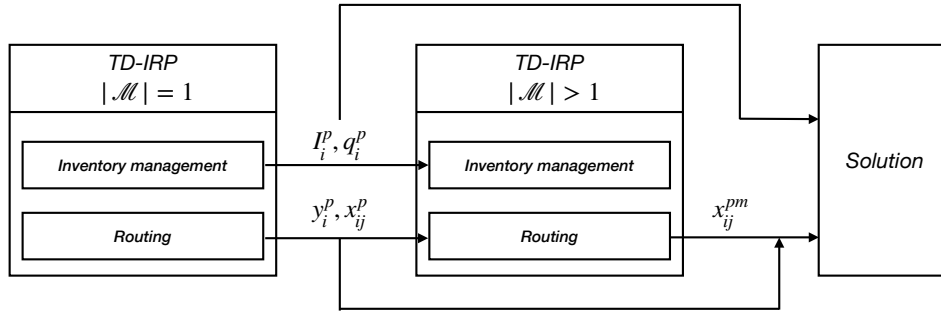

(b) Procedure for constant travelling time solutions re-solved in a time dependent environment

Figure 4.1 – Procedure for optimal TD-IRP solutions vs. constant travelling time solutions re-solved in a time dependent environment

#### 4.1.1 Numerical experiments

All experiments are conducted on a CPU Intel Xeon E5-1620 v3 @3.5Ghz with 64GB RAM in a Java-Gurobi environment. Gurobi 9.0.2 is used as a solver and the dynamic constraints are added using the *lazyConstraints* parameter. The experiments are conducted on all 250 instances generated in Section 3.3 with a time limit of 3600 seconds.

The results are presented in Table 4.1 and Table 4.2 as follows: Columns  $|\mathcal{H}|$ ,  $|\mathcal{V}'|$ , and  $|\mathcal{M}|$  present, respectively, the length of the horizon, the number of clients in the network and the number of time steps of the travelling time function. Columns  $z$ ,  $g$  and  $CPU$  present, respectively, the objective value, the gap to the best lower bound found and the execution time of the solution of the TD-IRP. These values are average values over five instances of each combination of parameters  $\mathcal{H}$ ,  $\mathcal{V}'$  and  $\mathcal{M}$ . Columns  $z_{|\mathcal{M}|=1}$ ,  $g_{|\mathcal{M}|=1}$  and  $CPU_{|\mathcal{M}|=1}$  represent, respectively, the objective value, the gap to the best lower bound and the execution time, in average, of the TD-IRP when the solution with constant travelling time is re-solved in a time dependent environment. Finally, column  $g_{z_{|\mathcal{M}|=1}}^z$  represents the gap between the objectives values  $z$  and  $z_{|\mathcal{M}|=1}$  where  $g_{z_{|\mathcal{M}|=1}}^z = \frac{z_{|\mathcal{M}|=1} - z}{z}$ .

$ \mathcal{V}' $	$ \mathcal{M} $	$z$	$g\%$	$CPU$	$z_{ \mathcal{M} =1}$	$g_{ \mathcal{M} =1}\%$	$CPU_{ \mathcal{M} =1}$	$g_{z_{ \mathcal{M} =1}}^z\%$
5	1	3790.27	0.00	0.00				
	12	3387.27	0.00	0.00	3398.27	0.00	0.00	0.32
	30	3136.02	0.00	0.01	3136.47	0.00	0.00	0.02
	60	2916.07	0.00	0.02	2926.07	0.00	0.00	0.34
	120	2584.09	0.00	0.05	2611.27	0.00	0.00	1.25
10	1	5544.34	0.00	0.04				
	12	4906.04	0.00	0.06	4927.14	0.00	0.00	0.44
	30	4579.25	0.00	0.55	4628.34	0.00	0.01	1.09
	60	4183.26	0.00	1.10	4237.14	0.00	0.02	1.25
	120	3752.34	0.00	45.97	3829.54	0.00	0.05	2.02
15	1	6822.30	0.00	0.07				
	12	6169.50	0.00	0.32	6230.70	0.00	0.01	0.99
	30	5823.55	0.00	4.46	5963.70	0.00	0.04	2.45
	60	5346.01	0.00	70.24	5470.30	0.00	0.23	2.37
	120	4701.56	0.45	1610.18	4885.90	0.00	1.17	3.94
20	1	8588.07	0.00	0.28				
	12	7699.65	0.00	4.87	7833.87	0.00	0.02	1.68
	30	7198.26	0.00	782.55	7375.67	0.00	0.13	2.43
	60	6622.56	0.75	2240.37	6900.47	0.00	2.78	4.18
	120	6025.68	4.47	3600.03	6285.47	0.00	2.02	4.42
25	1	9246.05	0.00	0.78				
	12	8426.63	0.00	160.87	8536.65	0.00	0.04	1.32
	30	7864.11	0.80	2308.50	8025.05	0.00	0.41	2.05
	60	7378.17	4.16	3600.03	7547.05	0.00	26.22	2.35
	120	6807.12	9.92	3600.04	6870.65	0.00	430.99	0.94
30	1	10611.99	0.00	0.73				
	12	9615.59	0.29	2397.94	9710.79	0.00	0.15	0.97
	30	9160.58	2.85	3600.02	9220.39	0.00	4.81	0.63
	60	8599.19	6.21	3600.03	8606.79	0.19	1232.12	0.10
	120	7761.99	8.21	3600.10	7820.39	0.24	1825.42	0.76

Table 4.1 – Results for the comparison between optimal TDIRP solutions and constant travelling time solutions re-solved in a time dependent environment for  $|\mathcal{H}| = 3$ .

$ \mathcal{V}' $	$ \mathcal{M} $	$z$	$g\%$	$CPU$	$z_{ \mathcal{M} =1}$	$g_{ \mathcal{M} =1}\%$	$CPU_{ \mathcal{M} =1}$	$g_{z_{ \mathcal{M} =1}}^z\%$
5	1	8385.85	0.00	0.04				
	12	7514.45	0.00	0.03	7520.65	0.00	0.00	0.09
	30	6941.13	0.00	0.07	6942.45	0.00	0.00	0.02
	60	6448.17	0.00	0.21	6460.05	0.00	0.00	0.19
	120	5740.21	0.00	0.26	5796.45	0.00	0.01	1.04
10	1	11040.83	0.00	0.11				
	12	9856.17	0.00	0.27	9968.03	0.00	0.00	1.15
	30	9209.18	0.00	13.60	9344.03	0.00	0.01	1.52
	60	8496.00	0.00	47.21	8604.63	0.00	0.05	1.32
	120	7532.50	0.39	1074.80	7777.83	0.00	0.21	3.30
15	1	13923.93	0.00	0.47				
	12	12564.94	0.00	3.05	12683.13	0.00	0.02	0.91
	30	11923.00	0.00	495.22	12134.93	0.00	0.09	1.82
	60	10912.59	0.95	2929.27	11158.33	0.00	1.53	2.24
	120	9760.72	4.45	3600.02	9980.93	0.00	3.79	2.25
20	1	17726.17	0.00	2.16				
	12	15905.55	0.02	1143.01	16034.57	0.00	0.04	0.78
	30	14821.00	1.28	3600.01	15030.17	0.00	0.59	1.39
	60	13695.51	3.52	3600.03	13945.17	0.01	72.53	1.80
	120	12501.52	7.31	3600.04	12641.77	0.06	1535.07	1.11

Table 4.2 – Results for the comparison between optimal TDIRP solutions and constant travelling time solutions re-solved in a time dependent environment for  $|\mathcal{H}| = 6$ .

#### 4.1.2 Discussion

The results presented in Table 4.1 and Table 4.2 yield the following three observations:

The first observation is that TD-IRPs are difficult to solve. Indeed, instances with  $|\mathcal{V}'| \geq 20$  and  $|\mathcal{M}| \geq 30$ , among others, are not optimally solved within the time limit. Although the TD-IRP is not strictly a routing problem, routing problems of the order of 20, 25 and 30 clients are generally considered, in the VRP and TSP literature, as small instances. However, in a time dependent context, for an instance where  $|\mathcal{M}| = 120$ , all the routing variables are multiplied by  $|\mathcal{M}|$  which makes the problem 120 times bigger. Furthermore, the periodicity aspect adds to the difficulty by multiplying all variables by  $|\mathcal{H}|$ . Finally, since the problem is an integrated one, inventory decisions have a big impact on the size of the feasible solutions area, which adds another layer of difficulty to the TD-IRP.

Moreover, solutions of constant travelling time functions make good solutions in a time dependent environment. As we can see from column  $g_{z_{|\mathcal{M}|=1}}^z$ , the maximal gap between  $z$  and  $z_{|\mathcal{M}|=1}$  is of 4.42%.

Finally, the efficiency of the constant travelling time functions in a time dependent environment should be nuanced. Indeed, although the solutions of constant travelling time functions in a time dependent environment are indisputably good, they can be nuanced with the following considerations:

- the values of  $g_{z_{|\mathcal{M}|=1}}^z$  are average values over only 5 values, which can be misleading if the standard deviation is high enough. Figure 4.2 shows the distribution of these gaps. We can see from the figure that gaps can go up to 8.2% when  $|\mathcal{V}'|=20$  and  $|\mathcal{M}| = 120$ .
- As stated in the first observation, the TD-IRP is difficult to solve. Therefore, for instances when  $|\mathcal{V}'| \geq 25$ , the values of  $z$  are not optimal and have gaps up to 8.21% to the best lower bound found. On the other hand, the values of  $z_{|\mathcal{M}|=1}$  are mostly optimal and have a maximal gap to the best lower bound of 0.24%. Therefore, to have a better idea of how the gap is evolving, a comparison between  $z_{|\mathcal{M}|=1}$  and the best lower bound found when solving the time dependent problem  $z^{LB}$  is needed. Figure 4.3 presents the distribution of these gaps. We can see from the figure that the gaps can go up to 13.63% when  $|\mathcal{V}'| = 25$  and  $|\mathcal{M}| = 120$ .
- When looking closely at the structure of the optimal time dependent solutions, we notice that the inventory levels of the clients and the supplier are not extremely different from the solutions of when  $|\mathcal{M}| = 1$ . Therefore, the gaps presented in Table 4.1 and Table 4.2 are mostly transportation costs, as the inventory costs are almost equal. In this case, the gain in transportation

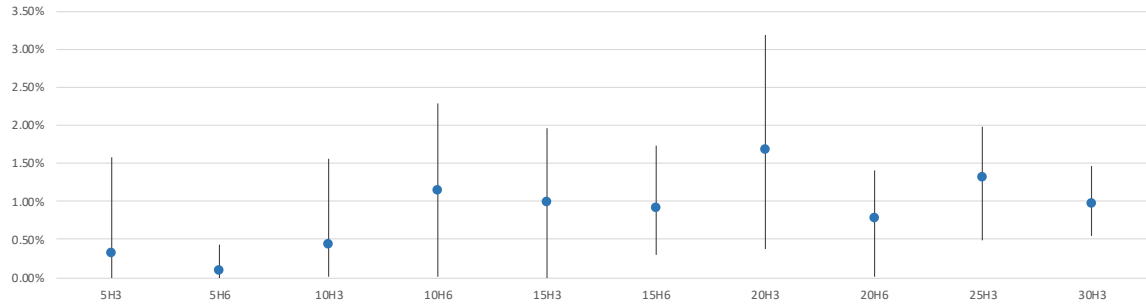

(a)  $|\mathcal{M}| = 12$

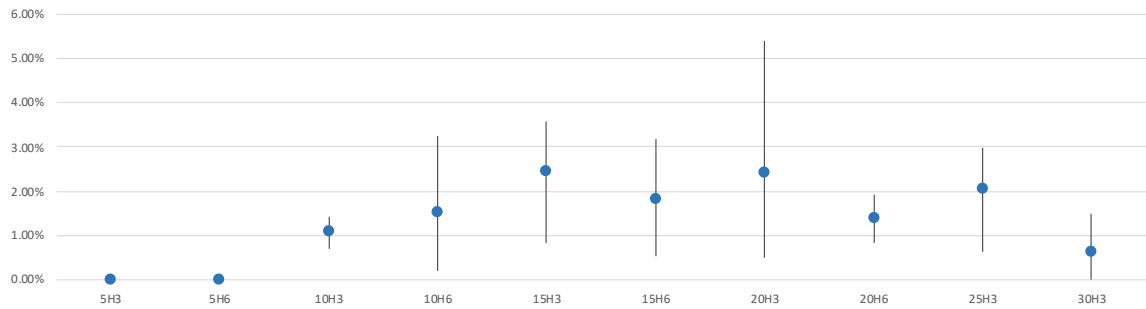

(b)  $|\mathcal{M}| = 30$

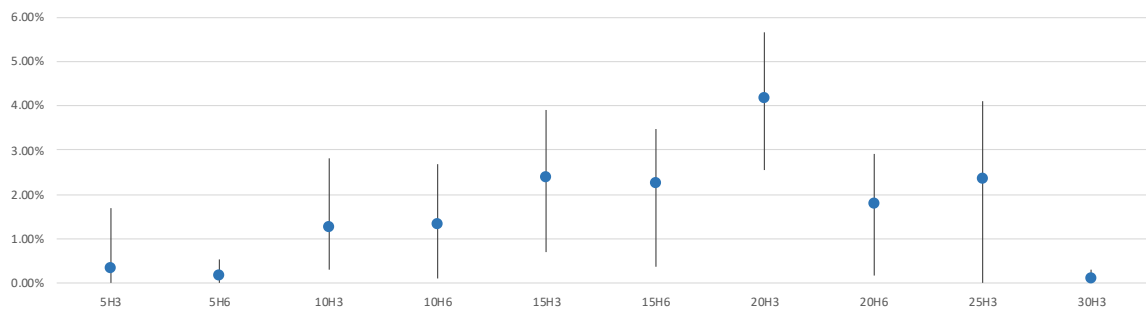

(c)  $|\mathcal{M}| = 60$

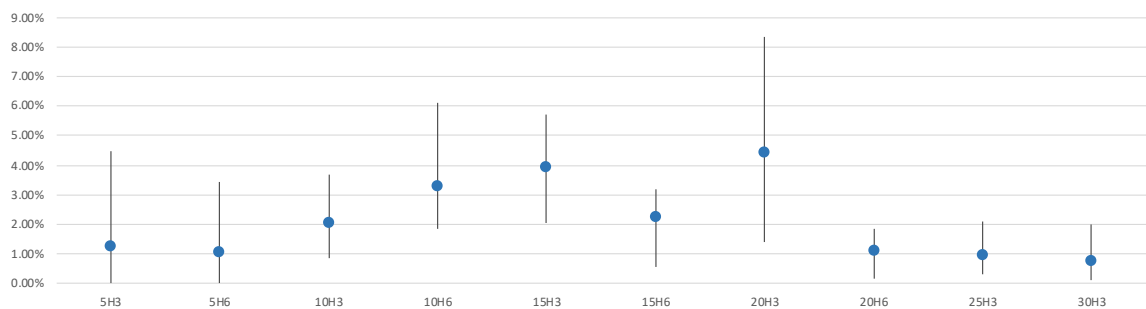

(d)  $|\mathcal{M}| = 120$

Figure 4.2 – Distribution of  $g_{z|M=1}^z$

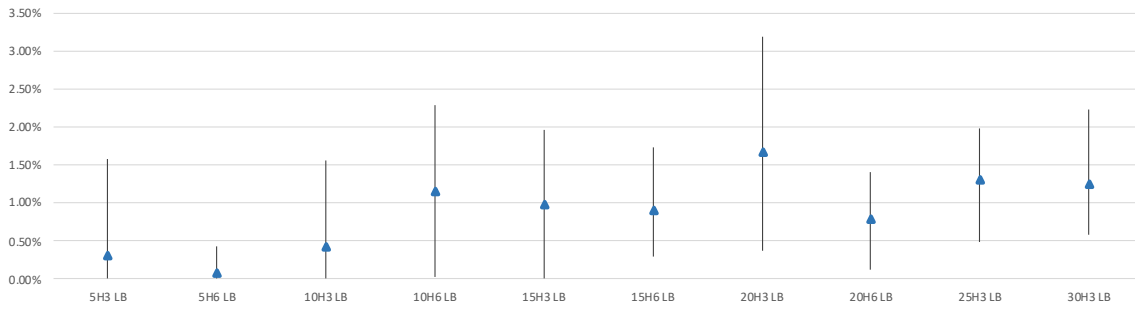

(a)  $|\mathcal{M}| = 12$

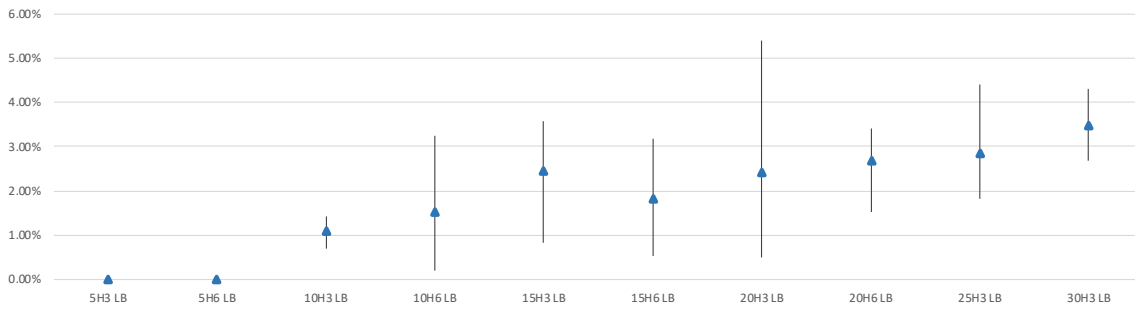

(b)  $|\mathcal{M}| = 30$

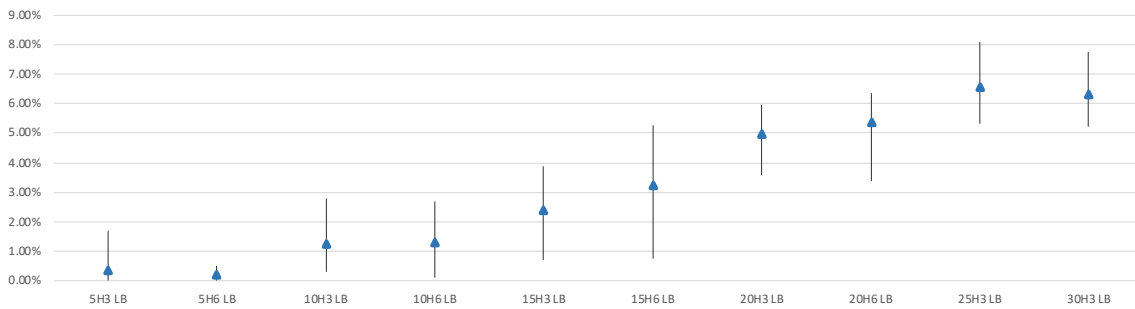

(c)  $|\mathcal{M}| = 60$

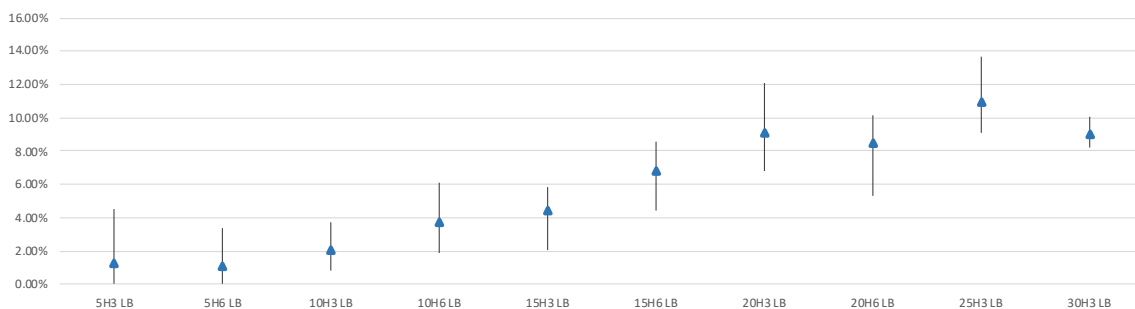

(d)  $|\mathcal{M}| = 120$

Figure 4.3 – Distribution of  $g_z^{LB}$



cost by optimising with time dependent travelling time functions is more important than indicated in the tables.

- Finally, in our model, we made the hypothesis that all tours start at the beginning of period  $p$ , i.e. at time step  $m = 0$ . This hypothesis can be very restrictive in a time dependent environment as the departure time can have a big influence on the optimal tour.

For all these reasons, we believe that optimising with time dependent functions can be beneficial in order to have cost-efficient solutions. However, solving large TD-IRP instances seems to be a computational challenge. Therefore, it is necessary to propose new algorithms to solve the TD-IRP more efficiently.

## 4.2 AN ASSIGN-AND-ROUTE MATHEURISTIC FOR THE TD-IRP

In [Section 4.1.2](#), we studied the structure of optimal TD-IRP solutions in comparison to solutions of constant travelling time functions when re-solved in a time dependent environment. This comparison showed that the difference between the two solutions lies mostly in the sequence in which the clients are visited, and rarely in the set of clients visited at each period  $p$  or the quantities sent and inventory levels of said clients. Therefore, we propose a matheuristic to solve the TD-IRP by decomposing the problem into two parts: First, defining the inventory level, the quantities to send for each client and the clients to visit for each period. Second, defining the sequence in which the clients will be visited and the departure time steps from each location.

### 4.2.1 Description of the matheuristic procedure

The results in [Section 4.1](#) show that optimal constant travelling time solutions when re-solved in a time dependent environment yield time dependent solutions that differ from optimal time dependent solutions, mostly in the routing component, and particularly the sequence of visiting the clients rather than the set of clients visited. Based on these observations, we propose a matheuristic that decomposes the problem into two parts: First, we define the inventory level, the quantities to send for each client and the clients to visit for each period by solving the problem using constant travelling time functions. Afterwards, for each period  $p \in \mathcal{H}$ , the sequence in which the clients are visited and the departure time steps from each location are defined by solving an independent TD-TSP. A mathematical formulation for the TD-TSP is presented below.  $\mathcal{V}_p$  represents the set of locations to visit for each period  $p$  and  $\mathcal{A}_p$  is a set of arcs linking them. Variables  $x_{ij}$  and  $x_{ij}^m$  represent the same variables as, respectively,  $x_{ij}^p$  and  $x_{ij}^{pm}$  –

but the index of period  $p$  is no longer needed, as the TD-TSPs of each period are solved independently.

The full decomposition procedure is described in detail in [Figure 4.4](#).

---

### TD-TSP

---

$$\min \text{obj} = c \sum_{(i,j) \in \mathcal{A}_p} \sum_{m \in \mathcal{M}} f(i, j, m) \times x_{ij}^m$$

$$\text{s.t} \quad \sum_{j \in \mathcal{V}_p \neq i} x_{ij} = 1 \quad \forall i \in \mathcal{V}_p \quad (52)$$

$$\sum_{j \in \mathcal{V}_p \neq i} x_{ji} = 1 \quad \forall i \in \mathcal{V}_p \quad (53)$$

$$\sum_{(i,j) \in \mathcal{S}} x_{ij} \leq |\mathcal{S}| - 1 \quad \forall \mathcal{S} \subseteq \mathcal{A}_p \quad (54)$$

$$\sum_{m \in \mathcal{M}} x_{ij}^m = x_{ij} \quad \forall (i, j) \in \mathcal{A}_p \quad (55)$$

$$\sum_{j \in \mathcal{V}'_p} x_{0j}^0 = 1 \quad (56)$$

$$\sum_{v_k \in P \setminus \{v_n\}} \sum_{m_k \in T} x_{v_k, v_{k+1}}^{m_k} \leq |P| - 2 \quad \forall [P, T] \text{ infeasible} \quad (57)$$

$$x_{ij} \in \{0, 1\} \quad \forall (i, j) \in \mathcal{A}_p \quad (58)$$

$$x_{ij}^m \in \{0, 1\} \quad \forall (i, j) \in \mathcal{A}_p, m \in \mathcal{M}' \quad (59)$$

---

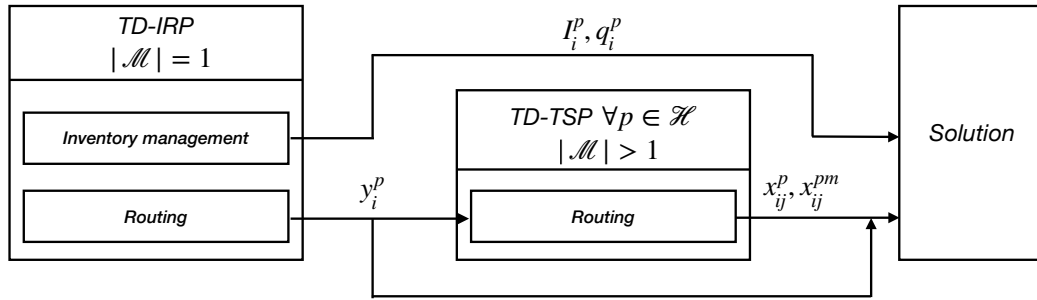

Figure 4.4 – A description of the matheuristic procedure

To optimally define the set of clients to be visited at each period  $p \in \mathcal{H}$ , the mathematical formulation presented in [Section 3.2.2.3](#) is paired to the branch-and-cut procedure presented in [Section 1.1.3](#). For the TD-TSP, the same branch-and-cut procedure is used paired to the TD-TSP mathematical formulation presented above.

The choice to use the same algorithms and mathematical formulations to solve the decomposition process enables a fairer comparison between the exact approach and the matheuristic, in order to show

more clearly the advantage of using such a decomposition. Indeed, better approaches in the literature exist that solve the TD-TSP more efficiently. But by using such state-of-the-art algorithms to solve the TD-TSP, the difference in performances would not be directly related to the decomposition approach but would instead be credited (at least partially) to the efficiency of the algorithms in question.

#### 4.2.2 Numerical experiments

In order to efficiently compare the performances of the proposed matheuristic compared to the exact approach, both approaches will be solved in the same time limit of 3600 seconds. For the exact approach, and since there is only one branch-and-cut algorithm to solve, the Gurobi time limit parameter is used. However, for the matheuristic, for instances with  $|\mathcal{H}| = 3$  and  $|\mathcal{H}| = 6$ , there are, respectively, 4 and 7 different models to solve: A TD-IRP when  $|\mathcal{M}| = 1$ , then independent TD-TSPs for each period  $p \in \mathcal{H}$ . Therefore, it is necessary to distribute the available computing time between these models in a way that ensures that all models are solved. In this case, the problem of defining the set of clients to visit is solved first with a 3600 seconds time limit, which is amply sufficient for this first step. The remaining time is then distributed equally between the different TD-TSPs. Afterwards, for each period  $p \in \mathcal{H}$ , if the TD-TSP is solved before its time limit, the remaining time is iteratively equally distributed on the not yet solved TD-TSPs. [Algorithm 4.1](#) presents the full procedure of the matheuristic.

The results of the comparison are shown in [Table 4.3](#) and [Table 4.4](#) as follows: Columns  $|\mathcal{H}|$ ,  $|\mathcal{V}'|$ , and  $|\mathcal{M}|$  present, respectively, the length of the horizon, the number of clients in the network and the number of time steps of the travelling time function. Columns  $z$ ,  $g\%$ ,  $CPU$  and  $z^{LB}$  present, respectively, the objective value, the gap to the best lower bound found, the execution time and the best lower bound found for the exact approach. These values are average values over five instances of each combination of parameters  $|\mathcal{H}|$ ,  $|\mathcal{V}'|$  and  $|\mathcal{M}|$ . Columns  $z_{MH}$ , and  $CPU_{MH}$  represent, respectively, the objective value and the execution time, in average, of the matheuristic. Finally, columns  $g_{z_{MH}}^z$ ,  $g_{z_{MH}}^{z^{LB}}$  and  $g_{CPU_{MH}}^{CPU}$  represent, respectively, the gap between  $z$  and  $z_{MH}$ , the gap between  $z_{MH}$  and  $z^{LB}$  and finally the gap between  $CPU_{MH}$  and  $CPU$  where:  $g_{z_{MH}}^z = \frac{z_{MH}-z}{z}$ ,  $g_{z_{MH}}^{z^{LB}} = \frac{z_{MH}-z^{LB}}{z^{LB}}$  and  $g_{CPU_{MH}}^{CPU} = \frac{CPU_{MH}-CPU}{CPU}$ . The values indexed with an asterisk represent the ones for which at least one TD-TSP is not optimally solved.

---

**Algorithm 4.1:** A matheuristic for the TD-IRP

---

- 1: **input:** instance  $\mathcal{S}$ , a number of time steps  $M$ , an empty solution  $\mathcal{S}$ , and a time limit  $TL = 3600$
  - 2: solve  $\mathcal{S}$  for  $|\mathcal{M}| = 1$
  - 3: fix the variables  $y_i^p$ ,  $q_i^p$  and  $I_i^p$  of  $\mathcal{S}$ .
  - 4: remaining time:  $RT = TL - CPU_{\mathcal{S}_{|\mathcal{M}|=1}}$
  - 5: **for**  $p \in \mathcal{H}$  **do**
  - 6:    $TL_p^{\text{TD-TSP}} = \frac{RT}{|\mathcal{H}|}$
  - 7: **end for**
  - 8: **for**  $p \in \mathcal{H}$  **do**
  - 9:   a set of locations to visit  $\mathcal{V}_p$  where  $\mathcal{V}_p \subseteq \mathcal{V}$
  - 10:   solve the TD-TSP for  $\mathcal{V}_p$  with  $|\mathcal{M}| = M$  and a time limit  $TL_p^{\text{TD-TSP}}$
  - 11:   remaining time from the TD-TSP of period  $p$ :  
     $RT_p^{\text{TD-TSP}} = TL_p^{\text{TD-TSP}} - CPU_p^{\text{TD-TSP}}$
  - 12:   **if**  $RT_p^{\text{TD-TSP}} > 0$  **then**
  - 13:     remaining set of unsolved TD-TSP  $\mathcal{H}^{\text{remaining}} = \mathcal{H} \setminus \{1, \dots, p\}$
  - 14:     **for**  $p' \in \mathcal{H}^{\text{remaining}}$  **do**
  - 15:        $TL_{p'}^{\text{TD-TSP}} = TL_{p'}^{\text{TD-TSP}} + \frac{RT_p^{\text{TD-TSP}}}{|\mathcal{H}^{\text{remaining}}|}$
  - 16:     **end for**
  - 17:   **end if**
  - 18:   set the values of variables  $x_{ij}^p$  and  $x_{ij}^{pm}$  for period  $p$
  - 19: **end for**
  - 20: **return**  $\mathcal{S}$
-

$ \mathcal{V}' $	$ \mathcal{M} $	$z$	$g\%$	$CPU$	$z^{LB}$	$z_{MH}$	$CPU_{MH}$	$g_{z_{MH}}^z \%$	$g_{z_{MH}}^{z^{LB}} \%$	$g_{CPU_{MH}}^{CPU} \%$
5	1	3790.27	0.00	0.00						
	12	3387.27	0.00	0.00	3387.27	3387.27	0.01	0.00	0.00	0.00
	30	3136.02	0.00	0.01	3136.02	3136.47	0.01	0.02	0.02	0.00
	60	2916.07	0.00	0.02	2916.07	2916.07	0.02	0.00	0.00	-15.00
	120	2584.09	0.00	0.05	2584.09	2597.47	0.03	0.57	0.57	-37.67
10	1	5544.34	0.00	0.04						
	12	4906.04	0.00	0.06	4906.04	4907.54	0.07	0.03	0.03	25.43
	30	4579.25	0.00	0.55	4579.25	4584.74	0.22	0.13	0.13	-59.89
	60	4183.26	0.00	1.10	4183.26	4188.54	0.46	0.13	0.13	-51.96
	120	3752.34	0.00	45.97	3752.34	3756.54	1.14	0.12	0.12	-76.48
15	1	6822.30	0.00	0.07						
	12	6169.50	0.00	0.32	6169.50	6198.90	0.40	0.50	0.50	37.14
	30	5823.55	0.00	4.46	5823.55	5852.10	1.14	0.51	0.51	-68.28
	60	5346.01	0.00	70.24	5346.01	5377.70	2.68	0.63	0.63	-94.91
	120	4701.56	0.45	1610.18	4681.23	4740.70	7.73	0.85	1.31	-97.62
20	1	8588.07	0.00	0.28						
	12	7699.65	0.00	4.87	7699.65	7734.47	1.29	0.43	0.43	-40.81
	30	7198.26	0.00	782.55	7198.10	7230.07	6.25	0.43	0.43	-96.85
	60	6622.56	0.75	2240.37	6574.74	6675.07	10.63	0.78	1.53	-98.64
	120	6025.68	4.47	3600.03	5756.28	6035.87	74.80	0.23	4.70	-97.92
25	1	9246.05	0.00	0.78						
	12	8426.63	0.00	160.87	8426.63	8463.05	8.23	0.43	0.43	-88.87
	30	7864.11	0.80	2308.50	7798.68	7909.45	70.73	0.58	1.38	-96.03
	60	7378.17	4.16	3600.03	7063.85	7357.05	826.04	-0.24	3.88	-77.05
	120	6807.12	9.92	3600.04	6132.34	6649.05*	2153.25	-2.30*	7.39*	-40.19
30	1	10611.99	0.00	0.73						
	12	9615.59	0.29	2397.94	9587.89	9648.99	79.33	0.35	0.64	-96.57
	30	9160.58	2.85	3600.02	8901.15	9143.19	1035.16	-0.20	2.64	-71.25
	60	8599.19	6.21	3600.03	8062.89	8427.79	1351.96	-1.95	4.13	-62.45
	120	7761.99	8.21	3600.10	7122.38	7752.59*	3600.03	-0.11*	8.10*	0.00

Table 4.3 – Matheuristic performances for  $|\mathcal{H}| = 3$

$ \mathcal{V}' $	$ \mathcal{M} $	$z$	$g\%$	$CPU$	$z^{LB}$	$z_{MH}$	$CPU_{MH}$	$g_{z_{MH}}^z \%$	$g_{z_{MH}}^{z^{LB}} \%$	$g_{CPU_{MH}}^{CPU} \%$
5	1	8385.85	0.00	0.04						
	12	7514.45	0.00	0.03	7514.27	7514.45	0.04	0.00	0.00	68.33
	30	6941.13	0.00	0.07	6940.97	6941.85	0.05	0.01	0.01	0.48
	60	6448.17	0.00	0.21	6448.17	6449.45	0.10	0.02	0.02	-32.19
	120	5740.21	0.00	0.26	5740.00	5741.25	0.12	0.02	0.02	-43.81
10	1	11040.83	0.00	0.11						
	12	9856.17	0.00	0.27	9855.96	9870.23	0.22	0.14	0.14	5.65
	30	9209.18	0.00	13.60	9209.18	9235.43	0.77	0.29	0.29	-86.55
	60	8496.00	0.00	47.21	8495.84	8525.23	1.35	0.35	0.35	-93.95
	120	7532.50	0.39	1074.80	7505.65	7578.83	3.16	0.64	1.02	-96.22
15	1	13923.93	0.00	0.47						
	12	12564.94	0.00	3.05	12564.94	12586.33	1.15	0.18	0.18	-51.14
	30	11923.00	0.00	495.22	11922.77	11948.73	3.56	0.23	0.23	-96.89
	60	10912.59	0.95	2929.27	10812.31	10947.33	7.25	0.33	1.28	-99.00
	120	9760.72	4.45	3600.02	9324.18	9721.13	26.58	-0.40	4.02	-99.26
20	1	17726.17	0.00	2.16						
	12	15905.55	0.02	1143.01	15902.29	15947.17	5.84	0.26	0.28	-94.54
	30	14821.00	1.28	3600.01	14636.60	14846.97	17.90	0.17	1.45	-99.50
	60	13695.51	3.52	3600.03	13216.30	13654.37	48.41	-0.28	3.22	-98.66
	120	12501.52	7.31	3600.04	11593.15	12251.17	205.82	-2.03	5.12	-94.28

Table 4.4 – Matheuristic performances for  $|\mathcal{H}| = 6$

### 4.2.3 Discussion

The results of [Table 4.3](#) and [Table 4.4](#) show that the matheuristic performs very well. These performances are discussed first in comparison to the best solutions found by the exact approach in [Section 4.1.1](#). In a second phase, they are compared to the best lower bounds found by the exact approach.

For all instances solved optimally with the exact approach, the maximal average gap between  $z_{MH}$  and  $z$  is of 0.63%, when  $|\mathcal{H}| = 3$ ,  $|\mathcal{V}'| = 15$  and  $|\mathcal{M}| = 60$ . [Figure 4.5](#) presents a more detailed look at how  $g_{z_{MH}}^z$  is distributed. As we can see in [Figure 4.5c](#), the largest gap for instances  $|\mathcal{H}| = 3$ ,  $|\mathcal{V}'| = 15$  and  $|\mathcal{M}| = 60$  is of 1.51% and one instance is solved optimally. Now for all instances, the maximal gap goes up to 2.47% when  $|\mathcal{V}'| = 30$  and  $|\mathcal{M}| = 120$  ([Figure 4.5d](#)) whereas the minimum gap goes down to  $-3.57\%$  when  $|\mathcal{V}'| = 30$  and  $|\mathcal{M}| = 60$  ([Figure 4.5c](#)). This means that the matheuristic is able to improve the best solution found by the exact approach within the time limit. Moreover, it does so in a shorter time, as shown by the gap in time  $g_{CPU_{MH}}^{CPU}$  which in this case is of  $-35.33\%$ .

Since not all instances can optimally be solved with the exact approach, we compare the performances of the matheuristic to the best lower bounds found by the exact approach in order to have a more accurate idea of how it is performing. [Figure 4.6](#) presents a more detailed look at the distribution of  $g_{z_{MH}}^{z^{LB}}$ . The largest gap  $g_{z_{MH}}^{z^{LB}}$  of the instances for which all the TD-TSPs in the matheuristic are solved optimally, i.e. the ones not indexed with an asterisk in [Table 4.3](#) and [Table 4.4](#), is observed for instances where  $|\mathcal{H}| = 6$ ,  $|\mathcal{V}'| = 20$  and  $|\mathcal{M}| = 120$ . The average gap is of 5.12% whereas the maximal and minimal gaps are of, respectively, 6.29% and 2.68%. For instances for which all the TD-TSPs are not optimally solved, e.g.  $|\mathcal{V}'| = \{25, 30\}$  and  $|\mathcal{M}| = 120$ , the maximal gap goes up to 11.45%. However, for these instances, the gaps can be reduced by improving the TD-TSPs that are not optimal, as the largest gap of these TD-TSPs to their best lower bound can go up to 22%. This can be done by exploiting the literature of TD-TSP which is getting increasingly richer, in comparison to the literature of TD-IRP which is almost nonexistent.

Moreover, it is worth noting that the values of  $z^{LB}$  are obtained using a branch-and-cut procedure. Therefore, the lower bound solutions have a high probability of containing sub-tours and time dependent infeasible paths. In this context, the gaps  $g_{z_{MH}}^{z^{LB}}$  that are observed when TD-IRPs are not optimally solved can be nuanced, as  $z^{LB}$  can be improved, which makes the real gap between  $z_{MH}$  and the optimal TD-IRP solutions even closer than  $g_{z_{MH}}^{z^{LB}}$ .

As a conclusion, the decomposition procedure of our matheuristic proves to be very efficient. The strengths of this matheuristic lie in the fact that it is inspired by observations of optimal TD-IRP solutions.

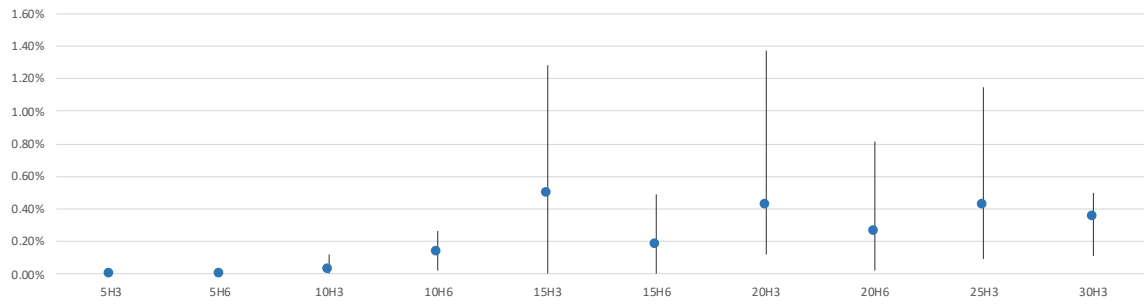

(a)  $|\mathcal{M}| = 12$

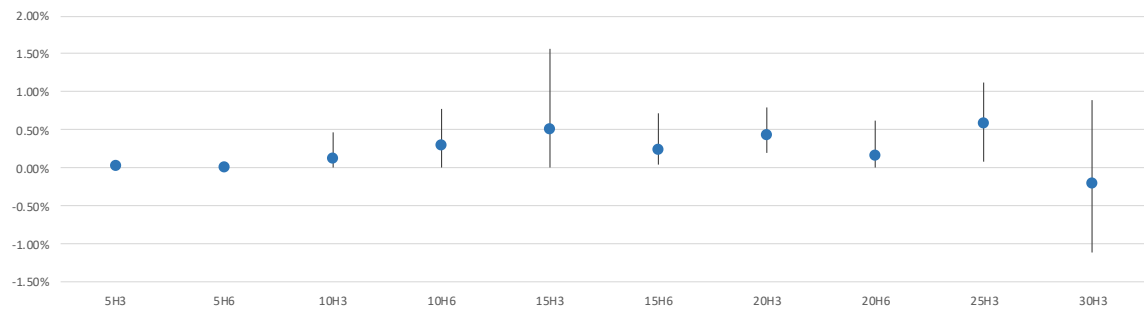

(b)  $|\mathcal{M}| = 30$

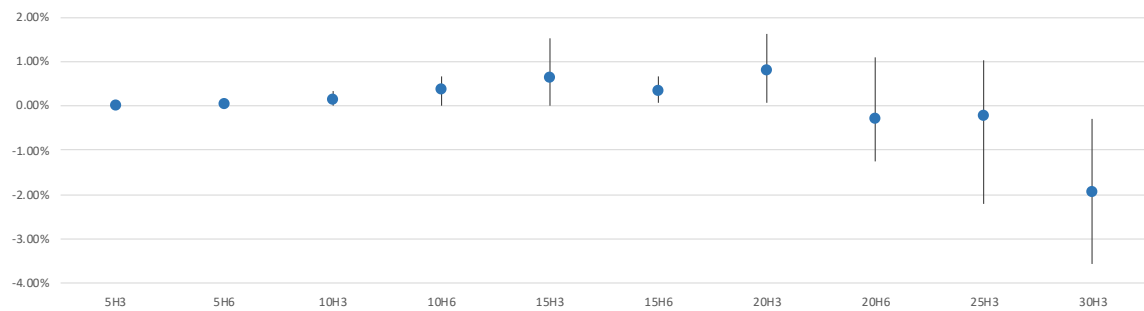

(c)  $|\mathcal{M}| = 60$

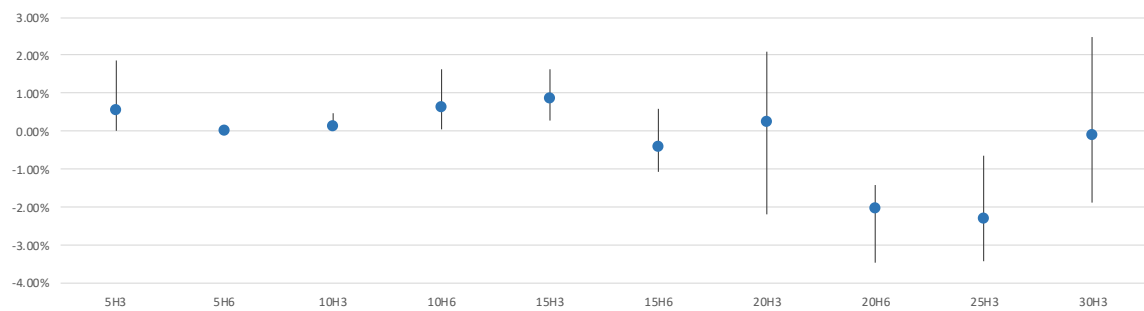

(d)  $|\mathcal{M}| = 120$

Figure 4.5 – Distribution of  $g_{z_{MH}}^z$



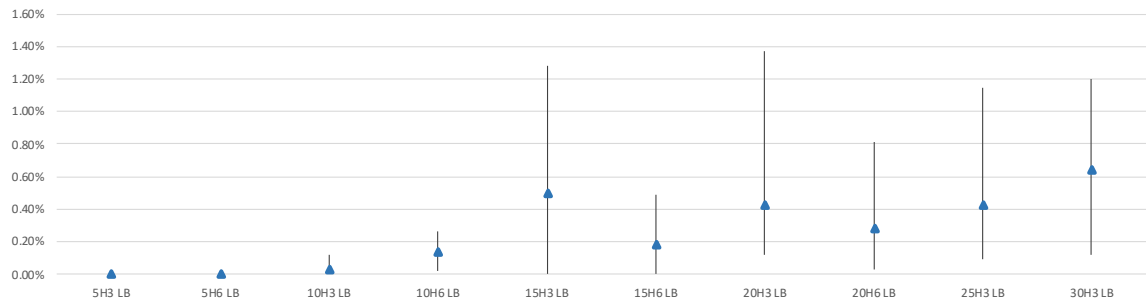

(a)  $|\mathcal{M}| = 12$

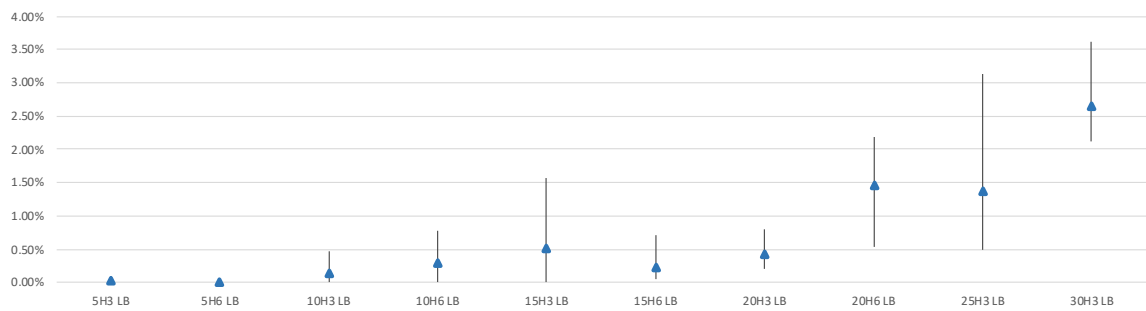

(b)  $|\mathcal{M}| = 30$

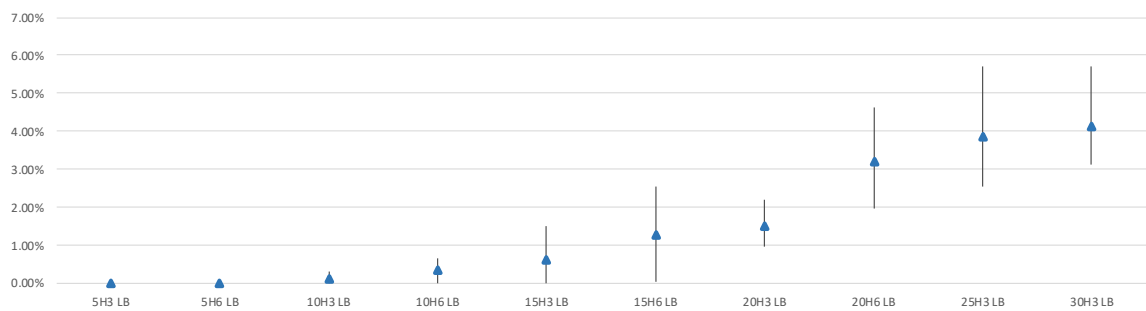

(c)  $|\mathcal{M}| = 60$

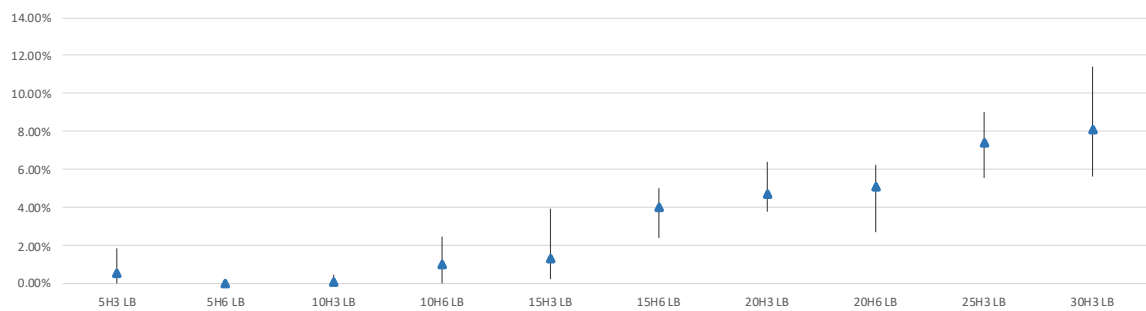

(d)  $|\mathcal{M}| = 120$

Figure 4.6 – Distribution of  $g_{MH}^{zLB}$

Moreover, it has the capacity of scaling as its improvement depends on the efficiency of the formulations and algorithms of IRP and TD-TSP, on which the literature is exponentially increasing.

## 4.3 CONCLUSION

### 4.3.1 *Contributions*

Following the results of [Chapter 3](#), this chapter investigates the impact of inventory decisions on the structure of optimal time dependent tours by comparing optimal TD-IRPs and optimal IRPs computed in a time dependent environment. The results show that optimising in a time dependent environment can be beneficial, cost-wise, and that, similarly to the results of Rifki et al. (2020) in the context of the TD-TSP, time-granularity has an impact on improving the cost. Based on the observations made on these results, a matheuristic that decomposes the problem into a problem of defining the set of clients to visit for each period first and routing second, is proposed. The results show that the proposed matheuristic is very efficient. Furthermore, its performances can be improved by taking advantage of the rich literature of time dependent routing problems in comparison to the very sparse literature of TD-IRP.

### 4.3.2 *Perspectives*

Perspectives in this context would be to take advantage of the rich literature of TD-TSPs to improve the matheuristic performances by implementing exact approaches that are more efficient than the branch-and-cut procedure used in this paper. In parallel, it is necessary to propose new valid inequalities for the TD-IRP that provide tighter lower bounds in order to efficiently assess the performances of the matheuristic. Improving the efficiency of solving the TD-IRP under the assumptions of this dissertation would greatly help extending the problem to other variants that are more complex, such as variable departure times instead of always departing at the beginning of the period.



## CONCLUSION

---

### CONTRIBUTIONS

The industrial world has seen an important evolution in the last century. The market has become more globalised and the competition fiercer. In an effort to keep up with the competition, industries are increasingly looking at supply chain operations as a means of gaining a considerable advantage over their competitors.

VMI is an added value logistics trend. It is a system in which the clients delegate the control of their inventory to the supplier. It is an advantageous situation for both actors, as the supplier is able to reduce the inventory and transportation costs by deciding how much quantity should be sent to each client and in which order to visit them for each period of a time horizon. For the clients, they longer need to dedicate resources in order to manage their replenishment. The resulting operational problem is called the IRP.

One of the issues that IRP is faced with is the uncertainty of its parameters. Since the IRP is an integrated problem, uncertainties can emanate from all of its different components and parameters, thus the range of uncertainty sources can be wide. This dissertation focuses on two of the most commonly faced uncertainties in real-life situations, the clients' demand and the travelling time.

In [Chapter 1](#), the state-of-the-art of IRP under uncertainty literature is established. The study shows that although the literature is quite rich, it is focused on stochastic and robust optimisation approaches, whereas the other *a priori* and *a posteriori* approaches are highly overlooked. This brings the question "*How to take into account demand and travelling time uncertainty in a different but realistic and efficient manner?*"

[Chapter 2](#) answers the question by focusing on the demand uncertainty. Due to multi-period dimension and the flexibility brought by the inventory, re-optimisation seems an appropriate approach. However, re-optimisation can yield solutions that are radically different from the original ones. Thus, it is necessary to ensure the stability of the solutions. A panel of stability metrics from the literature of routing, scheduling and inventory management are identified, re-adapted and mathematically formulated for the IRP. The behaviour of these metrics in relation to each other is investigated to show that they are highly correlated: optimising one means optimising the other. Moreover, the price of stability is examined and the results show that it is rather small.

Chapter 3 and Chapter 4 focus on the travelling time. In this case, an *a priori* but deterministic approach is proposed by considering the travelling time as time dependent. In Chapter 3, the literature of the IRP when travelling times are the main focus is reviewed and shows that the interest for the TD-IRP is fairly low. Thus, by turning to pure routing problems, ideas on how to formulate and solve the TD-IRP emerged. Four mathematical formulations for the TD-IRP, based on different discretisations of the time and the use of travelling time functions of different forms are proposed. To validate these formulations, a new benchmark of the TD-IRP is proposed, inspired by benchmarks of the IRP and TD-TSP literature. The conducted numerical experiments show that one of the four formulations performs better than the other three. However, it also shows that just as the other routing time dependent problems, the TD-IRP is harder to solve than its basic counterpart. In this context, Chapter 4 investigates the relevance of considering time dependent travelling times and the results show that it can be very cost effective. Moreover, based on the observations of optimal time dependent solutions made from these numerical experiments, a matheuristic is proposed. The results show that the matheuristic is very efficient and produce new upper bounds for numerous instances.

Finally, in a larger context, we believe our dissertation has two main contributions: First, it shows that even though approaches to manage uncertainties can be ill-suited for some problems such as re-optimisation with pure routing problems, by considering them for integrated problems, the multiple parameters and actors of the integrated problems can lift the limitations of said approaches, making them a viable option. Moreover, by studying the real sources of uncertainties, we realise that some uncertainties are not so unpredictable and can be lifted by representing the data in a different manner.

## PERSPECTIVES

Direct extensions of the models and approaches proposed in this dissertation are presented in the conclusions of each chapter. In the following, we list a few mid and long-term perspectives that scholars can ponder on.

Since the work presented in this thesis manages the uncertainty of the two most common parameters in IRP, and given that the ways of handling these uncertainties are not incompatible with each other, a natural perspective is to investigate the relevance of re-optimisation with stability metrics for the TD-IRP. This would enable the validation of other stability metrics related to the time component, such as the visiting time deviation. In addition, with such a model, the major sources of uncertainty, namely the client's demand and the travelling

time uncertainties would be managed.

Since there are different manners to handle uncertainty in the literature, such as *a priori* and *a posteriori* approaches, a perspective is to combine such approaches. Such combination is already studied in the literature by proposing *a priori* solutions, and once the uncertainty is revealed, infeasible solutions are repaired through *a posteriori* approaches. However, this can be done differently by studying the strength of each approach regarding different parameters. Ulmer (2019) tries to identify a threshold of degree of dynamism for which re-optimisation becomes more efficient than stochastic optimisation and vice-versa for the VRP. As the IRP is set in a multi-period context, another parameter that can be investigated is the time at which an event occurs. Which approach should be used if the chances of an event occurring are greater for a nearer or a more distant period? Although intuitively one can argue that events that may occur in closer periods can be more adequately handled with *a priori* approaches whereas more distant events are most suited to *a posteriori* ones, it would be interesting to validate this intuition, and furthermore identify the threshold for which this change occurs.

One of the biggest sources of uncertainty is the lack of control over the data. Indeed, we have seen in this dissertation that it is possible to lift uncertainties related to travelling times by proposing travelling time functions that are time dependent. Since we live in a world where data is increasingly available, a perspective is to extend this idea to other uncertainties by studying their sources and trying to determine deterministic parameters that cause them. This is already done in the literature for the service time for example, where in the same manner as the travelling time, it is considered in a time dependent environment for the TD-TSP (Taş et al., 2016). However, time dependent service time takes in consideration only a part of the uncertainty related to the service time. The other part depends on the quantity that needs to be unloaded at each client. This problem can be very important in routing problems in general such as the TD-TSP and TD-VRP. Pure routing problems do not have a multi-period dimension, thus all clients need to be visited in one period. Therefore, a service time that depends on the quantity to deliver only helps assessing more accurately the length of tour. On the other hand, for the TD-IRP it is even more relevant due to its multi-period context. Indeed, such a parameter can have an impact, not only on the length of the tour, but on the whole structure of a TD-IRP solution, since in some cases it is more beneficial to do multiple small deliveries over the periods of the time horizon rather than a big delivery that might take up a lot of unloading time. This is a problem that arises for products that take a long time to be unloaded, for example fuel. In

gas stations, it is very common to interrupt the service when refilling the fuel tanks. As this idle time can have an impact on the station's earnings, it may be wiser to determine several small replenishment at a time where the affluence is not high rather than a large replenishment that can extend to a time where the affluence is high.

Another issue that has preoccupied scholars in recent years is sustainability. Many researchers have been interested in this problem within the context of the IRP by proposing models where the greenhouse gas emitted is minimised based on the travelled distances and the load of the truck. However, we believe that distance is not an element that allows an accurate computation of the amount of greenhouse gas emissions. As emissions depend on the speed at which the engine is running, it is well known that when driving on highways, it is possible to travel large distances but with a regime that is fairly regular, which means that the emission is not extremely high. On the other hand, when in an urban logistics context, there are a lot of idle times where no distance is travelled but greenhouse gases are emitted, and by braking regularly, the regime of the engine is always high, causing higher emissions. One perspective is to compare the distance element to other elements, such as the travelling time, the speed of the vehicle, or a more accurate element: the revolutions per minute of the engine.

As stated in [Section 1.3](#), although re-optimisation does not have a reputation for being effective when it comes to pure problems, in the case of integrated problems, it is possible that the different parameters of the problems can cater for the limitations that re-optimisation imposes. One perspective would be to investigate the relevance of using re-optimisation for other integrated problems such as the location routing problem or the integrated process plan and scheduling problem.

Finally, a perspective is to propose new models that cater for other challenges that reality imposes by integrating other sub-problems of the supply chain to the IRP. A problem that can generally be faced in transport problems is optimising the packing of the products inside of the distribution vehicle (3D packing). Indeed, due to the limited capacity of the vehicles, by packing the products in an efficient manner, capacity can be gained. Moreover, due to the limited access points in a vehicle, it is very important to pack the products in the vehicle in the most ergonomic way possible taking into account the sequence in which customers will be visited. This is even more important in an urban logistics context where it is necessary to be reactive in order not to waste time, since the availability of parking slots is rather limited, which does not offer too much flexibility. Another problem that can

be integrated to the IRP is the lot-sizing. Indeed, the number of the products available to the supplier in the IRP is always considered as a given data. However, by integrating the production problem to the IRP, it is possible to greatly reduce the cost of inventory, especially when considering the transshipment parameter which could play a role of safety stock if ever faced with a production shortage due to uncertainties.





## BIBLIOGRAPHY

---

- Aghezzaf, El Houssaine (2008). « Robust distribution planning for supplier-managed inventory agreements when demand rates and travel times are stationary. » In: *Journal of the Operational Research Society* 59.8, pp. 1055–1065.
- Agra, Agostinho, Marielle Christiansen, Alexandrino Delgado, and Lars Magnus Hvattum (2015). « A maritime inventory routing problem with stochastic sailing and port times. » In: *Computers and Operations Research* 61, pp. 18–30.
- Agra, Agostinho, Marielle Christiansen, Lars Magnus Hvattum, and Filipe Rodrigues (2018). « Robust optimization for a maritime inventory routing problem. » In: *Transportation Science* 52.3, pp. 509–525.
- Al-Ameri, Tareq A., Nilay Shah, and Lazaros G. Papageorgiou (2008). « Optimization of vendor-managed inventory systems in a rolling horizon framework. » In: *Computers and Industrial Engineering* 54.4, pp. 1019–1047.
- Alarcon Ortega, Emilio J., Michael Schilde, and Karl F. Doerner (2020). « Matheuristic search techniques for the consistent inventory routing problem with time windows and split deliveries. » In: *Operations Research Perspectives* 7.May, p. 100152.
- Alkaabneh, Faisal, Ali Diabat, and Huaizhu Oliver Gao (2020). « Benders decomposition for the inventory vehicle routing problem with perishable products and environmental costs. » In: *Computers and Operations Research* 113.
- Andersson, Henrik, Arild Hoff, Marielle Christiansen, Geir Hasle, and Arne Løkketangen (2010). « Industrial aspects and literature survey: Combined inventory management and routing. » In: *Computers & Operations Research* 37.9, pp. 1515–1536.
- André, Jean, Eric Bourreau, and Roberto Wolfler Calvo (2020). « Introduction to the Special Section: ROADEF/EURO Challenge 2016—Inventory Routing Problem. » In: *Transportation Science* 54.2, pp. 299–301.
- Archetti, Claudia, Luca Bertazzi, Gilbert Laporte, and Maria Grazia Speranza (2007). « A branch-and-cut algorithm for a vendor-managed inventory-routing problem. » In: *Transportation Science* 41.3, pp. 382–391.
- Archetti, Claudia, Luca Bertazzi, and M Grazia Speranza (2003). « Re-optimizing the traveling salesman problem. » In: *Networks: An International Journal* 42.3, pp. 154–159.
- Arigliano, Anna, Gianpaolo Ghiani, Antonio Grieco, Emanuela Guerriero, and Isaac Plana (2019). « Time-dependent asymmetric trav-

- eling salesman problem with time windows: Properties and an exact algorithm. » In: *Discrete Applied Mathematics* 261, pp. 28–39.
- Armstrong & Associates, Inc." (Oct. 2020). *Third party logistics market information*.
- Ausiello, Giorgio, Bruno Escoffier, Jérôme Monnot, and Vangelis Paschos (2009). « Reoptimization of minimum and maximum traveling salesman's tours. » In: *Journal of Discrete Algorithms* 7.4, pp. 453–463.
- Ban, Ha Bang (2019). « An efficient two-phase metaheuristic algorithm for the time dependent traveling salesman Pproblem. » In: *RAIRO - Operations Research* 53.3, pp. 917–935.
- Bell, Walter J, Louis M Dalberto, Marshall L Fisher, Arnold J Greenfield, Ramchandran Jaikumar, Pradeep Kedia, Robert G Mack, and Paul J Prutzman (1983). « Improving the distribution of industrial gases with an on-line computerized routing and scheduling optimizer. » In: *Interfaces* 13.6, pp. 4–23.
- Bertazzi, Luca, Adamo Bosco, and Demetrio Laganà (2015). « Managing stochastic demand in an Inventory Routing Problem with transportation procurement. » In: *Omega* 56, pp. 112–121.
- Bertazzi, Luca, Leandro C. Coelho, Annarita De Maio, and Demetrio Laganà (2019). « A matheuristic algorithm for the multi-depot inventory routing problem. » In: *Transportation Research Part E* 122, pp. 524–544.
- Bertazzi, Luca and M. Grazia Speranza (2012). « Inventory routing problems: an introduction. » In: *EURO Journal on Transportation and Logistics* 1.4, pp. 307–326.
- Bertazzi, Luca and M. Grazia Speranza (2013). « Inventory routing problems with multiple customers. » In: *EURO Journal on Transportation and Logistics* 2.3, pp. 255–275.
- Bertsimas, Dimitris J. (1992). « A vehicle routing problem with stochastic demand. » In: *Operations Research* 40.3, pp. 574–585.
- Bertsimas, Dimitris, Swati Gupta, and Joel Tay (2016). « Scalable robust and adaptive inventory routing. » In: *Available on Optimization Online*.
- Bilò, Davide, Hans-Joachim Böckenhauer, Juraj Hromkovič, Richard Královič, Tobias Mömke, Peter Widmayer, and Anna Zych (2008). « Reoptimization of Steiner trees. » In: *Scandinavian Workshop on Algorithm Theory*. Springer, pp. 258–269.
- Böckenhauer, Hans-Joachim, Luca Forlizzi, Juraj Hromkovic, Joachim Kneis, Joachim Kupke, Guido Proietti, and Peter Widmayer (2007). « On the approximability of TSP on local modifications of optimally solved instances. » In: *Algorithmic Operations Research* 2.2, p. 83.
- Böckenhauer, Hans-Joachim, Juraj Hromkovič, Richard Královič, Tobias Mömke, and Peter Rossmanith (2009). « Reoptimization of

- Steiner trees: Changing the terminal set. » In: *Theoretical computer science* 410.36, pp. 3428–3435.
- Böckenhauer, Hans-Joachim and Dennis Komm (2010). « Reoptimization of the metric deadline TSP. » In: *Journal of Discrete Algorithms* 8.1, pp. 87–100.
- Boria, Nicolas and Federico Della Croce (2014). « Reoptimization in machine scheduling. » In: *Theoretical Computer Science* 540, pp. 13–26.
- Boria, Nicolas, Jérôme Monnot, and Vangelis Th Paschos (2013). « Reoptimization of maximum weight induced hereditary subgraph problems. » In: *Theoretical Computer Science* 514, pp. 61–74.
- Boria, Nicolas and Vangelis T. Paschos (2011). « A survey on combinatorial optimization in dynamic environments. » In: *RAIRO - Operations Research* 45.3, pp. 241–294.
- Chen, Yee Ming and Chun Ta Lin (2009). « A coordinated approach to hedge the risks in stochastic inventory-routing problem. » In: *Computers and Industrial Engineering* 56.3, pp. 1095–1112.
- Cho, Dong Won, Young Hae Lee, Tae Youn Lee, and Mitsuo Gen (2014). « An adaptive genetic algorithm for the time dependent inventory routing problem. » In: *Journal of Intelligent Manufacturing* 25.5, pp. 1025–1042.
- Cho, Jaeyoung, Gino J Lim, Seon Jin Kim, and Taofeek Biobaku (2018). « Liquefied natural gas inventory routing problem under uncertain weather conditions. » In: *International Journal of Production Economics* 204, pp. 18–29.
- Chow, Joseph Y J (2014). « Activity-based travel scenario analysis with routing problem reoptimization. » In: *Computer-Aided Civil and Infrastructure Engineering* 29.2, pp. 91–106.
- Chow, Joseph Y.J. (2016). « Dynamic UAV-based traffic monitoring under uncertainty as a stochastic arc-inventory routing policy. » In: *International Journal of Transportation Science and Technology* 5.3, pp. 167–185.
- Christiansen, Marielle and Bjørn Nygreen (2005). « Robust inventory ship routing by column generation. » In: *Column generation*. Springer, pp. 197–224.
- Church, Laura K. and Reha Uzsoy (1992). « Analysis of periodic and event-driven rescheduling policies in dynamic shops. » In: *International Journal of Computer Integrated Manufacturing* 5.3, pp. 153–163.
- Coelho, Leandro C., Jean-François Cordeau, and Gilbert Laporte (2012). « The inventory-routing problem with transshipment. » In: *Computers & Operations Research* 39.11, pp. 2537–2548.
- Coelho, Leandro C., Jean-François Cordeau, and Gilbert Laporte (2014a). « Thirty years of inventory routing. » In: *Transportation Science* 48.1, pp. 1–19.

- Coelho, Leandro C. and Gilbert Laporte (2014b). « Improved solutions for inventory-routing problems through valid inequalities and input ordering. » In: *International Journal of Production Economics* 155, pp. 391–397.
- Coelho, Leandro Callegari, Annarita De Maio, and Demetrio Laganà (2020). « A variable MIP neighborhood descent for the multi-attribute inventory routing problem. » In: *Transportation Research Part E: Logistics and Transportation Review* 144, September, p. 102137.
- Cowling, Peter and Marcus Johansson (2002). « Using real time information for effective dynamic scheduling. » In: *European Journal of Operational Research* 139.2, pp. 230–244.
- Curry, J. and B. Peters (2005). « Rescheduling parallel machines with stepwise increasing tardiness and machine assignment stability objectives. » In: *International Journal of Production Research* 43.15, pp. 3231–3246.
- Delage, Erwann, N Bostel, P Dejax, and M Gendreau (2010). « Re-optimization of technician tours in dynamic environments with stochastic service time. » In: *Master thesis*.
- Delgado, Karina Valdivia, Pedro Yuri A. L. Alves, and Valdinei Freire (2018). « Inventory routing problem with time windows : A systematic review of the literature. » In: *Proceedings of the XIV Brazilian Symposium on Information Systems*, pp. 215–222.
- Deng, Ye, Wanhong Zhu, Hongwei Li, and Yonghui Zheng (2018). « Multi-type ant system algorithm for the time dependent vehicle routing problem with time windows. » In: *Journal of Systems Engineering and Electronics* 29.3, pp. 625–638.
- Dertouzos, Michael L and Aloysius K Mok (1989). « Multiprocessor online scheduling of hard-real-time tasks. » In: *IEEE Transactions on software engineering* 15.12, pp. 1497–1506.
- Desaulniers, Guy, Jørgen G Rakke, and Leandro C Coelho (2016). « A branch-price-and-cut algorithm for the inventory-routing problem. » In: *Transportation Science* 50.3, pp. 1060–1076.
- Desrochers, Martin and François Soumis (1988). « A reoptimization algorithm for the shortest path problem with time windows. » In: *European Journal of Operational Research* 35.2, pp. 242–254.
- Dettenbach, Astrid M C and Sarah Ubber (2015). « Managing disruptions in last mile distribution. » In: *48th Hawaii International Conference on System Sciences (HICSS)*, pp. 1078–1087.
- Diz, Gustavo Souto dos Santos, Silvio Hamacher, and Fabricio Oliveira (2019). « A robust optimization model for the maritime inventory routing problem. » In: *Flexible Services and Manufacturing Journal* 31.3, pp. 675–701.
- Dong, Yachao, Christos T. Maravelias, and Norman F. Jerome (2018). « Reoptimization framework and policy analysis for maritime inventory routing under uncertainty. » In: *Optimization and Engineering* 19.4, pp. 937–976.

- Ercan, Secil and Didem Cinar (2017). « A multiproduct multi-vehicle inventory routing problem with uncertainty. » In: *Springer Optimization and Its Applications* 129, pp. 181–198.
- Fang, Hsiao-Lan, Peter Ross, and Dave Corne (1993). « A promising genetic algorithm approach to job-shop scheduling, rescheduling, and open-shop scheduling problems. » In: *Fifth International Conference on Genetic Algorithms*. 623, pp. 375–382.
- Fang, Wei, Shengxiang Yang, and Xin Yao (2015). « A survey on problem models and solution approaches to rescheduling in railway networks. » In: *IEEE Transactions on Intelligent Transportation Systems* 16.6, pp. 2997–3016.
- Fardi, Keyvan, Saeid Jafarzadeh Ghouschi, and Ashkan Hafezalkotob (2019). « An extended robust approach for a cooperative inventory routing problem. » In: *Expert Systems with Applications* 116, pp. 310–327.
- Farias, Katyanne, Khaled Hadj-Hamou, and Claude Yugma (2021). « Model and exact solution for a two-echelon inventory routing problem. » In: *International Journal of Production Research* 59.10, pp. 3109–3132.
- Fleischmann, Bernhard, Martin Gietz, and Stefan Gnutzmann (2004). « Time-varying travel times in vehicle routing. » In: *Transportation Science* 38.2, pp. 160–173.
- Franceschetti, Anna, Emrah Demir, Dorothee Honhon, Tom Van Woensel, Gilbert Laporte, and Mark Stobbe (2017). « A metaheuristic for the time-dependent pollution-routing problem. » In: *European Journal of Operational Research* 259.3, pp. 972–991.
- Frederickson, Greg N (1985). « Data structures for on-line updating of minimum spanning trees, with applications. » In: *SIAM Journal on Computing* 14.4, pp. 781–798.
- Gendreau, Michel, Gianpaolo Ghiani, and Emanuela Guerriero (2015). « Time-dependent routing problems: A review. » In: *Computers and Operations Research* 64, pp. 189–197.
- Ghasemi, Elaheh and Mahdi Bashiri (2018). « A selective covering-inventory- routing problem to the location of bloodmobile to supply stochastic demand of blood. » In: *International Journal of Industrial Engineering & Production Research* 29.2, pp. 147–158.
- Gruler, Aljoscha, Javier Panadero, Jesica de Armas, José A. Moreno Pérez, and Angel A. Juan (2018). « Combining variable neighborhood search with simulation for the inventory routing problem with stochastic demands and stock-outs. » In: *Computers and Industrial Engineering* 123.June, pp. 278–288.
- Guimarães, Thiago A., Leandro C. Coelho, Cleder M. Schenekemberg, and Cassius T. Scarpin (2019). « The two-echelon multi-depot inventory-routing problem. » In: *Computers and Operations Research* 101, pp. 220–233.

- Hansknecht, Christoph, Imke Joormann, and Sebastian Stiller (2018). « Cuts, primal heuristics, and learning to branch for the time-dependent traveling salesman problem. » In: *arXiv*.
- Harris, Ford W (1919). « How many parts to make at once. » In: *Factory, The Magazine of Management* 10.2, pp. 135–136.
- Harsono, Alexander (2013). « How Walmart and P&G Can Enhance Supply Chain Management with CPFR Initiatives. » In: *Academia*.
- Haughton, M. A. (2000). « Quantifying the benefits of route reoptimisation under stochastic customer demands. » In: *Journal of the Operational Research Society* 51.3, pp. 320–332.
- Herrera, Carlos, Sana Belmokhtar-Berraf, André Thomas, and Víctor Parada (2016). « A reactive decision-making approach to reduce instability in a master production schedule. » In: *International Journal of Production Research* 54.8, pp. 2394–2404.
- Herroelen, Willy and Roel Leus (2005). « Project scheduling under uncertainty: Survey and research potentials. » In: *European Journal of Operational Research* 165.2, pp. 289–306.
- Hu, Hao, Jian Li, and Xiang Li (2018). « A credibilistic goal programming model for inventory routing problem with hazardous materials. » In: *Soft Computing* 22.17, pp. 5803–5816.
- Huang, Shan Huen and Pei Chun Lin (2010). « A modified ant colony optimization algorithm for multi-item inventory routing problems with demand uncertainty. » In: *Transportation Research Part E: Logistics and Transportation Review* 46.5, pp. 598–611.
- Hvattum, Lars Magnus and Arne Løkketangen (2009). « Using scenario trees and progressive hedging for stochastic inventory routing problems. » In: *Journal of Heuristics* 15.6, pp. 527–557.
- Ichoua, Soumia, Michel Gendreau, and Jean Yves Potvin (2003). « Vehicle dispatching with time-dependent travel times. » In: *European Journal of Operational Research* 144.2, pp. 379–396.
- Inderfurth, Karl (1994). « Nervousness in inventory control : analytical results. » In: *Operations-Research-Spektrum* 16.2, pp. 113–123.
- Jafarian, Ahmad, Nasrin Asgari, Seyed Sina, and Elham Fatemi-sadr (2019). « The inventory-routing problem subject to vehicle failure. » In: *Transportation Research Part E* 126, pp. 254–294.
- Juan, Angel A., Scott E. Grasman, Jose Caceres-Cruz, and Tolga Bektaş (2014). « A simheuristic algorithm for the Single-Period Stochastic Inventory-Routing Problem with stock-outs. » In: *Simulation Modelling Practice and Theory* 46, pp. 40–52.
- Kadipasaoglu, S. N. and S. V. Sridharan (1997). « Measurement of instability in multi-level MRP systems. » In: *International Journal of Production Research* 35.3, pp. 713–737.
- Karoonsoontawong, Ampol and Avinash Unnikrishnan (2013). « Inventory routing problem with route duration limits and stochastic inventory capacity constraints : Tabu search heuristics. » In:

- Transportation Research Record: Journal of the Transportation Research Board* 2378.1, pp. 43–53.
- Kazemi, Seyed Mahmood, Masoud Rabbani, Reza Tavakkoli-Moghaddam, and Farid Abolhassani Shahreza (2017). « Blood inventory-routing problem under uncertainty. » In: *Journal of Intelligent and Fuzzy Systems* 32.1, pp. 467–481.
- Kimms, A. (1998). « Stability measures for rolling schedules with applications to capacity expansion planning, master production scheduling, and lot sizing. » In: *Omega* 26.3, pp. 355–366.
- Kleywegt, Anton J., Vijay S. Nori, and Martin W. P. Savelsbergh (2004). « Dynamic programming approximations for a stochastic inventory routing problem. » In: *Transportation Science* 38.1, pp. 42–70.
- Lefever, Wouter (2018a). « An effective sample average approximation algorithm for the Inventory-Routing Problem with Transshipment under stochastic demand. » In: *ILS 2018 - Information Systems, Logistics and Supply Chain, Proceedings*, pp. 115–124.
- Lefever, Wouter (2018b). « Stochastic and robust optimization algorithms for the inventory-routing problem. » PhD thesis. Universiteit Gent.
- Lefever, Wouter, El Houssaine Aghezzaf, and Khaled Hadj-Hamou (2016). « A convex optimization approach for solving the single-vehicle cyclic inventory routing problem. » In: *Computers and Operations Research* 72, pp. 97–106.
- Lefever, Wouter, Faycal A Touzout, Khaled Hadj-Hamou, and El-Houssaine Aghezzaf (2021). « Benders' decomposition for robust travel time-constrained inventory routing problem. » In: *International Journal of Production Research* 59.2, pp. 342–366.
- Lera-Romero, Gonzalo, Juan José Miranda-Bront, and Francisco J Soullignac (2020). « Dynamic programming for the time-dependent traveling salesman problem with time windows. » In: *Technical report, Optimization Online*.
- Levenshtein, V. I. (1966). « Binary codes capable of correcting deletions, insertions and reversals. » In: *Cybernetics and Control Theory* 10.8, pp. 845–848.
- Li, Kunpeng, Bin Chen, Appa Iyer Sivakumar, and Yong Wu (2014). « An inventory-routing problem with the objective of travel time minimization. » In: *European Journal of Operational Research* 236.3, pp. 936–945.
- Li, Ming, Zheng Wang, and Felix T. S. Chan (2016a). « A robust inventory routing policy under inventory inaccuracy and replenishment lead-time. » In: *Transportation Research Part E: Logistics and Transportation Review* 91, pp. 290–305.
- Li, Ming, Zheng Wang, and Felix T. S. Chan (2016b). « An inventory routing policy under replenishment lead time. » In: *IEEE Transactions on Systems, Man and Cybernetics* 47.12, pp. 3150–3164.



- Lin, Neng-Pai, Lee Kraje, G Keong Leong, and W C Benton (1994). « The effects of environmental factors on the design of master production scheduling systems. » In: *Journal of Operations Management* 11, pp. 367–384.
- Liu, Changshi, Gang Kou, Xiancheng Zhou, Yi Peng, Huyi Sheng, and Fawaz E. Alsaadi (2020). « Time-dependent vehicle routing problem with time windows of city logistics with a congestion avoidance approach. » In: *Knowledge-Based Systems* 188, p. 104813.
- Lu, Ji, Yuning Chen, Jin-Kao Hao, and Renjie He (2020). « The Time-Dependent Electric Vehicle Routing Problem: Model and Solution. » In: *Expert Systems with Applications* 161, p. 113593.
- Malandraki, C. and M. Daskin (1992). « Time dependent vehicle routing problems: Formulations, properties and heuristic algorithms. » In: *Transportation Science* 26.3, pp. 185–200.
- Malekly, Hooman (2015). « The inventory pollution-routing problem under uncertainty. » In: *Green Logistics and Transportation*. Springer, Cham., pp. 83–117.
- Mangiaracina, Riccardo, Marco Melacini, and Alessandro Perego (2012). « A critical analysis of vendor managed inventory in the grocery supply chain. » In: *International Journal of Integrated Supply Management* 7.1-3, pp. 138–166.
- Melgarejo, Penélope Aguiar, Philippe Laborie, and Christine Solnon (2015). « A time-dependent no-overlap constraint: Application to urban delivery problems. » In: *International Conference on AI and OR Techniques in Constraint Programming for Combinatorial Optimization Problems*. Springer, Cham., pp. 1–17.
- Micheli, Guido J.L. and Fabio Mantella (2018). « Modelling an environmentally-extended inventory routing problem with demand uncertainty and a heterogeneous fleet under carbon control policies. » In: *International Journal of Production Economics* 204.November 2017, pp. 316–327.
- Minh Vu, Duc, Mike Hewitt, Natashia Boland, and Martin Savelsbergh (2018). « Solving time dependent traveling salesman problems with time windows. » In: *Optimization Online* 6640.
- Miranda-Bront, Juan José, Isabel Méndez-Díaz, and Paula Zabala (2010). « An integer programming approach for the time-dependent TSP. » In: *Electronic Notes in Discrete Mathematics* 36.C, pp. 351–358.
- Mirzapour Al-e-Hashem, S M J and Yacine Rekik (2013). « Multi-product multi-period inventory routing problem with a transshipment option : A green approach. » In: *International Journal of Production Economics Journal of Production Economics* 157, pp. 80–88.
- Mirzapour Al-e-hashem, Seyed M.J., Yacine Rekik, and Ebrahim Mohammadi Hoseinhajlou (2019). « A hybrid L-shaped method to solve a bi-objective stochastic transshipment-enabled inventory routing problem. » In: *International Journal of Production Economics* 209.July 2018, pp. 381–398.

- Monnot, Jérôme (2015). « A note on the traveling salesman reoptimization problem under vertex insertion. » In: *Information Processing Letters* 115.3, pp. 435–438.
- Montero, Agustín, Isabel Méndez-Díaz, and Juan José Miranda-Bront (2017). « An integer programming approach for the time-dependent traveling salesman problem with time windows. » In: *Computers and Operations Research* 88, pp. 280–289.
- Narayanan, Arunachalam and Powell Robinson (2010). « Evaluation of joint replenishment lot-sizing procedures in rolling horizon planning systems. » In: *International Journal of Production Economics* 127.1, pp. 85–94.
- Niakan, Farzad and Mohammad Rahimi (2015). « A multi-objective healthcare inventory routing problem; a fuzzy possibilistic approach. » In: *Transportation Research Part E: Logistics and Transportation Review* 80, pp. 74–94.
- Nikzad, Erfaneh, Mahdi Bashiri, and Fabricio Oliveira (2019). « Two-stage stochastic programming approach for the medical drug inventory routing problem under uncertainty. » In: *Computers and Industrial Engineering* 128. July 2017, pp. 358–370.
- Nolz, Pamela, Nabil Absi, and Dominique Feillet (2014). « A stochastic inventory routing problem for infectious medical waste collection. » In: *Networks* 63.1, pp. 82–95.
- Nori, Vijay S and Martin W P Savelsbergh (2002). « The stochastic inventory routing problem with direct deliveries. » In: *Transportation Science* 36.1, pp. 94–118.
- Pan, Binbin, Zhenzhen Zhang, and Andrew Lim (2021). « Multi-trip time-dependent vehicle routing problem with time windows. » In: *European Journal of Operational Research* 291.1, pp. 218–231.
- Pfeiffer, András, Botond Kádár, and László Monostori (2007). « Stability-oriented evaluation of rescheduling strategies, by using simulation. » In: *Computers in Industry* 58.7, pp. 630–643.
- Raa, Birger and El Houssaine Aghezzaf (2009). « A practical solution approach for the cyclic inventory routing problem. » In: *European Journal of Operational Research* 192, pp. 429–441.
- Rahbari, A, M M Nasiri, and E Ghorbani (2017). « An inventory routing problem for perishable products with demand and transportation time uncertainty: A robust optimization approach. » In: *The 10th International Conference of Iranian Operations Research Society*.
- Rahim, Mohd Kamarul Irwan Abdul, Yiqing Zhong, El Houssaine Aghezzaf, and Tarik Aouam (2014). « Modelling and solving the multiperiod inventory-routing problem with stochastic stationary demand rates. » In: *International Journal of Production Research* 52.14, pp. 4351–4363.
- Rahimi, Mohammad, Armand Baboli, and Yacine Rekik (2017). « Multi-objective inventory routing problem: A stochastic model to con-

- sider profit, service level and green criteria. » In: *Transportation Research Part E: Logistics and Transportation Review* 101, pp. 59–83.
- Rakke, Jørgen Glomvik, Magnus Stålhane, Christian Rørholt Moe, Marielle Christiansen, Henrik Andersson, Kjetil Fagerholt, and Inge Norstad (2011). « A rolling horizon heuristic for creating a liquefied natural gas annual delivery program. » In: *Transportation Research Part C: Emerging Technologies* 19.5, pp. 896–911.
- Rangsaritratsamee, Ruedee, William G. Ferrell, and Mary Beth Kurz (2004). « Dynamic rescheduling that simultaneously considers efficiency and stability. » In: *Computers and Industrial Engineering* 46.1, pp. 1–15.
- Rifki, Omar, Nicolas Chiabaut, and Christine Solnon (2020). « On the impact of spatio-temporal granularity of traffic conditions on the quality of pickup and delivery optimal tours. » In: *Transportation Research Part E: Logistics and Transportation Review* 142.July 2019, p. 102085.
- Rincon-Garcia, Nicolas, Ben Waterson, Tom J. Cherrett, and Fernando Salazar-Arrieta (2020). « A metaheuristic for the time-dependent vehicle routing problem considering driving hours regulations – An application in city logistics. » In: *Transportation Research Part A: Policy and Practice* 137.November 2018, pp. 429–446.
- Rodrigues, Filipe, Agostinho Agra, Marielle Christiansen, Lars Magnus Hvattum, and Cristina Requejo (2019). « Comparing techniques for modelling uncertainty in a maritime inventory routing problem. » In: *European Journal of Operational Research* 277.3, pp. 831–845.
- Rohnert, Hans (1985). « A dynamization of the all pairs least cost path problem. » In: *Annual Symposium on Theoretical Aspects of Computer Science*. Springer, pp. 279–286.
- Roldán, Raúl F, Rosa Basagoiti, and Leandro C Coelho (2017). « A survey on the inventory-routing problem with stochastic lead times and demands. » In: *Journal of Applied Logic* 24, pp. 15–24.
- Rosenkrants, Daniel, Richard Stearns, and Philip Lewis (1977). « An analysis of several heuristics for the traveling salesman problem. » In: *SIAM Journal on Computing* 6.388, p. 563.
- Sahin, Funda, E. Powell Robinson, and Li Lian Gao (2008). « Master production scheduling policy and rolling schedules in a two-stage make-to-order supply chain. » In: *International Journal of Production Economics* 115.2, pp. 528–541.
- Salavati-Khoshghalb, Majid, Michel Gendreau, Ola Jabali, and Walter Rei (2019). « A hybrid recourse policy for the vehicle routing problem with stochastic demands. » In: *EURO Journal on Transportation and Logistics* 8.3, pp. 269–298.
- Schäffter, Markus W. (1997). « Scheduling with forbidden sets. » In: *Discrete Applied Mathematics* 72.1-2, pp. 155–166.

- Schönberger, Jörn and Herbert Kopfer (2008). « Schedule nervousness reduction in transport re-planning. » In: *Communications of SIWN* 3, pp. 7–14.
- Secomandi, Nicola and François Margot (2009). « Reoptimization approaches for the vehicle-routing problem with stochastic demands. » In: *Operations Research* 57.1, pp. 214–230.
- Solyalı, Oğuz, Jean-François Cordeau, and Gilbert Laporte (2012). « Robust inventory routing under demand uncertainty. » In: *Transportation Science* 46.3, pp. 327–340.
- Sörensen, Kenneth (2006). « Route stability in vehicle routing decisions: a bi-objective approach using metaheuristics. » In: *Central European Journal of Operations Research* 14.2, pp. 193–207.
- Soysal, Mehmet (2016). « Closed-loop Inventory Routing Problem for returnable transport items. » In: *Transportation Research Part D: Transport and Environment* 48.December 2015, pp. 31–45.
- Soysal, Mehmet, Jacqueline M. Bloemhof-Ruwaard, Rene Haijema, and Jack G.A.J. Van Der Vorst (2015). « Modeling an inventory routing problem for perishable products with environmental considerations and demand uncertainty. » In: *International Journal of Production Economics* 164, pp. 118–133.
- Soysal, Mehmet, Jacqueline M. Bloemhof-Ruwaard, Rene Haijema, and Jack G.A.J. van der Vorst (2018). « Modeling a green inventory routing problem for perishable products with horizontal collaboration. » In: *Computers and Operations Research* 89, pp. 168–182.
- Spliet, Remy, Adriana F. Gabor, and Rommert Dekker (2014). « The vehicle rescheduling problem. » In: *Computers and Operations Research* 43.1, pp. 129–136.
- Sridharan, Sri V., William L. Berry, and V. Udayabhanu (1988). « Measuring Master Production Schedule Stability Under Rolling Planning Horizons. » In: *Decision Sciences* 19.1, pp. 147–166.
- Sun, Peng, Lucas P. Veelenturf, Said Dabia, and Tom Van Woensel (2018). « The time-dependent capacitated profitable tour problem with time windows and precedence constraints. » In: *European Journal of Operational Research* 264.3, pp. 1058–1073.
- Taş, Duygu, Michel Gendreau, Ola Jabali, and Gilbert Laporte (2016). « The traveling salesman problem with time-dependent service times. » In: *European Journal of Operational Research* 248.2, pp. 372–383.
- Timajchi, Ali, S M J Mirzapour Al-e-Hashem, and Yacine Rekik (2019). « Inventory routing problem for hazardous and deteriorating items in the presence of accident risk with transshipment option. » In: *International Journal of Production Economics* 209, pp. 302–315.
- Trudeau, Pierre and Moshe Dror (1992). « Stochastic inventory routing: Route design with stockouts and route failures. » In: *Transportation Science* 26.3, pp. 171–184.

- Ulmer, Marlin W (2019). « Anticipation vs. reoptimization for dynamic vehicle routing with stochastic requests. » In: *Networks: An International Journal* 73.3, pp. 277–291.
- Wang, Xuping, Junhu Ruan, Hongyan Shang, and Chao Ma (2011). *A combinational disruption recovery model for vehicle routing problem with time windows*. Berlin, Heidelberg: Springer, pp. 3–12.
- Wu, S. David, Robert H. Storer, and Pei Chann Chang (1993). « One-machine rescheduling heuristics with efficiency and stability as criteria. » In: *Computers and Operations Research* 20.1, pp. 1–14.
- Yang, Zhiwei, Michael Emmerich, Thomas Bäck, and Joost Kok (2016). « Multi-objective inventory routing with uncertain demand using population-based metaheuristics. » In: *Integrated Computer-Aided Engineering* 23.3, pp. 205–220.
- Yu, Yugang, Chengbin Chu, Haoxun Chen, and Feng Chu (2012). « Large scale stochastic inventory routing problems with split delivery and service level constraints. » In: *Annals of Operations Research* 197.1, pp. 135–158.
- Zhang, Chengliang, George Nemhauser, Joel Sokol, and Myun-seok Cheon Dimitri Papageorgiou (2015). *Robust inventory routing with flexible time window allocation*. Tech. rep. Atlanta: Georgia Institute of Technology, pp. 1–19.
- Zhang, Xiaoxia and Lixin Tang (2007). « Disruption management for the vehicle routing problem. » In: *International Conference on Intelligent Computing*, pp. 225–234.
- Zhao, P.X., W.H. Luo, and X. Han (2019). « Time dependent and bi-objective vehicle routing problem with time windows. » In: *Advances in Production Engineering & Management* 14.2, pp. 201–212.
- Zweben, Monte, Eugene Davis, Brian Daun, and Michael J. Deale (1993). « Scheduling and rescheduling with iterative repair. » In: *IEEE Transactions on Systems, Man and Cybernetics* 23.6, pp. 1588–1596.

## COLOPHON

This document was typeset using the typographical look-and-feel `classicthesis` developed by André Miede. The style was inspired by Robert Bringhurst's seminal book on typography "*The Elements of Typographic Style*". `classicthesis` is available for both  $\LaTeX$  and  $\text{LyX}$ :

<https://bitbucket.org/amiede/classicthesis/>

Happy users of `classicthesis` usually send a real postcard to the author, a collection of postcards received so far is featured here:

<http://postcards.miede.de/>

*Final Version* as of September 27, 2021 (`classicthesis`).



## FOLIO ADMINISTRATIF

### THESE DE L'UNIVERSITE DE LYON OPEREE AU SEIN DE L'INSA LYON

NOM : Touzout

DATE de SOUTENANCE : 08/10/2021

Prénoms : Fayçal Atik

TITRE : Inventory Routing Problem: Gestion des incertitudes liées à la demande et aux temps de trajets

NATURE : Doctorat

Numéro d'ordre : 2021LYSEI064

Ecole doctorale : InfoMaths

Spécialité : Génie Industriel

#### RESUME :

L'Inventory Routing Problem (IRP) est l'intégration de deux sous-problèmes de la chaîne logistique: la gestion de stock et le transport. Un défi commun à toutes les opérations de la chaîne logistique est la gestion de l'incertitude ; cela s'applique également à l'IRP. Les approches les plus courantes de prendre en compte les incertitudes dans la littérature sont les approches "a priori". Les approches "a priori" gèrent les incertitudes de manière proactive en établissant des plans de réapprovisionnement robustes, qui seront réalisables même face à un large éventail d'événements. Dans cette thèse on s'attaque aux deux sources majeures d'incertitudes dans le contexte de l'IRP: la demande des clients et les temps de trajets. L'incertitude liée à la demande des clients est gérée par une approche "a posteriori" de ré-optimisation avec des mesures de stabilité. Les métriques de stabilité de la littérature des sous-problèmes de l'IRP tels que le transport et la gestion des stocks ou des problèmes de séquençage similaires tels que l'ordonnancement sont réadaptés pour l'IRP. Ces métriques sont formulées et leur corrélation et leur impact sur le coût étudiés. Pour les temps de trajets, l'incertitude est gérée de manière "a priori" mais déterministe en les considérant comme dépendants du temps. Dans ce contexte, quatre formulations mathématiques pour l'IRP dépendant du temps (TD-IRP) inspirées de la riche littérature des problèmes de transport dépendant du temps sont proposées. Les quatre formulations sont comparées sur un nouveau benchmark généré basé sur des benchmarks de la littérature de l'IRP et Time-Dependent Travelling Salesman Problem (TD-TSP). La pertinence de considérer des temps de parcours dépendant du temps est étudiée et une matheuristique proposée afin de résoudre des instances de grande taille.

MOTS-CLÉS : Inventory routing problem, incertitude, demande, temps de trajets, stabilité, ré-optimisation, time-dependent

Laboratoire (s) de recherche :

Décision et Information pour les Systèmes de Production (DISP)

Directeur de thèse:

Khaled Hadj-Hamou

Président de jury :

Nadia Brauner

Composition du jury :

Nabil Absi, Professeur, Ecole des Mines de Saint-Etienne

Marc Sevaux, Professeur des Universités, Université Bretagne Sud

Nadia Brauner, Professeur des Universités, Université Grenoble Alpes

Maxime Ogier, Maître de conférences, Université de Lille

Anne-Laure Ladier, Maître de conférences, INSA Lyon

Khaled Hadj-Hamou, Professeur des Universités, INSA Lyon

Rapporteur

Rapporteur

Examinatrice

Examineur

Co-encadrante

Directeur de thèse