



HAL
open science

Windings of the planar Brownian motion and Green's formula

Isao Sauzedde

► **To cite this version:**

Isao Sauzedde. Windings of the planar Brownian motion and Green's formula. Probability [math.PR]. Sorbonne Université, 2021. English. NNT : 2021SORUS437 . tel-03783516

HAL Id: tel-03783516

<https://theses.hal.science/tel-03783516>

Submitted on 22 Sep 2022

HAL is a multi-disciplinary open access archive for the deposit and dissemination of scientific research documents, whether they are published or not. The documents may come from teaching and research institutions in France or abroad, or from public or private research centers.

L'archive ouverte pluridisciplinaire **HAL**, est destinée au dépôt et à la diffusion de documents scientifiques de niveau recherche, publiés ou non, émanant des établissements d'enseignement et de recherche français ou étrangers, des laboratoires publics ou privés.

SORBONNE UNIVERSITÉ
École Doctorale des Sciences Mathématiques de Paris Centre
Laboratoire de Probabilités, Statistique et Modélisation

THÈSE DE DOCTORAT
Discipline : **Mathématiques**

présentée par
Isao SAUZEDDE

Windings of the planar Brownian motion and Green's formula

dirigée par **Thierry LÉVY**

Rapporteurs :

Nathanaël BERESTYCKI Universität Wien
Christophe GARBAN Université Lyon 1

Soutenue le 12 novembre 2021 devant le jury composé de :

Nathanaël BERESTYCKI	Universität Wien
Quentin BERGER	Sorbonne Université
Christophe GARBAN	Université Lyon 1
Jean-François LE GALL	Université Paris-Saclay
Thierry LÉVY	Sorbonne Université
Perla SOUSI	University of Cambridge
Zhan SHI	NYU Shanghai

My propositions are elucidatory in this way: he who understands me finally recognizes them as senseless, when he has climbed out through them, on them, over them. (He must so to speak throw away the ladder, after he has climbed up on it.)

Tractatus Logico-Philosophicus (translated from the original German), Ludwig Wittgenstein

Remerciements

Je suis en tout premier lieu infiniment reconnaissant à Thierry Lévy pour toute l'attention qu'il m'a consacrée depuis son cours sur le champ de Yang-Mills, qui a été le déclencheur de mon travail. Il m'a été d'un grand secours à tous niveaux, scientifiques comme affectifs.

Je suis également très reconnaissant à mes deux rapporteurs de thèse, Nathanaël Berestycki et Christophe Garban, pour le temps qu'ils ont passé à lire et à comprendre ma thèse, ainsi qu'aux autres membres du jury. Je suis très honoré de pouvoir leur présenter mon travail.

Du côté des mathématiques, je dois aussi remercier Max pour tout ce qu'il m'a appris, et pour l'amour des maths qu'il m'a transmis, ainsi que Pierre, qui m'a fait découvrir la géométrie, et qui a écouté et commenté à maintes reprises mon travail. Je remercie encore tous ceux qui ont écouté et répondu à mes élucubrations et questionnements, parfois vides ou presque de sens ou d'intérêt.

Du côté sentimental, c'est bien sûr à Anne-Elisabeth que je dois le plus, pour son support indéfectible, malgré mon humeur lunatique et mon esprit lunaire, pendant toute la durée de ma thèse. Celle-ci a tout de même été pour moi une véritable épreuve émotionnelle, dans laquelle j'ai eu la chance d'être épaulé aussi par mes parents et par mes soeurs, auxquels je dois tout ce que je suis. À Céleste, je dois une oreille attentive, et un canapé sur lequel poser la mienne. L'aventure de la thèse fut aussi l'aventure parisienne, et fut un peu la nôtre. Et ce fut un plaisir.

Je suis également plein de gratitude envers celles et ceux qui m'ont accompagné, pendant ou avant la thèse, et qui m'ont permis de m'épanouir pendant toutes mes études. Je pense aux informaticiens (ce qui inclus, mais pour des raisons différentes, Amandine et Martin), pour toutes les joies – mais surtout les peines, soyons honnêtes – que l'on a partagées. Je pense aux Lyonnais plus généralement, ceux du foyer, des élus étudiants ou d'ailleurs, pour tous les miams – mais surtout les bières, soyons honnêtes – que l'on a partagés. La pandémie aura coupé trop brutalement mes liens avec beaucoup d'entre eux, mais ils sont toujours dans mon coeur. Je pense aussi à la diaspora qu'est devenue le groupe du master, et dont j'attends avec impatience le rassemblement. Je pense aussi à mes co-bureaux et à mes collègues.

Beaucoup d'entre vous connaissent ma tendance à m'excuser plutôt qu'à remercier. Je tiens à cette détestable habitude, et présente donc mes excuses pour tout le temps dont j'ai manqué et pour tous les contacts que je n'ai pas réussi à maintenir. Enfin, je m'excuse pour toutes les personnes que j'ai oubliées...

Contents

Introduction (en français)	v
F1 Contenu de la thèse	v
F2 Une brève histoire des enlacements du mouvement brownien	vii
F3 Présentation des résultats et organisation de la thèse	ix
Introduction (in English)	xvii
E1 Content of the thesis	xvii
E2 A short story of the Brownian windings	xix
E3 Presentation of the results and organisation of the thesis	xxi
Notation	xxix
1 Curves and windings	xxix
2 Measures and probability laws	xxx
3 Exponents and asymptotic notations	xxxi
I Large winding sets of the Brownian motion	1
1 Prelude: Green’s formula in Young integration theory	3
1.1 Introduction	3
1.2 Proof of Theorem 1.1.1	6
2 Estimation of the large winding area	11
2.1 Introduction	11
2.2 Area of large winding for independent Brownian motions	12
2.3 Asymptotics on average	22
2.4 Asymptotics in L^2	26
2.5 Asymptotics in L^p	31
2.6 Almost sure asymptotics	34
2.7 About the value of the gap	36
3 Distribution of the large winding set	41
3.1 Introduction	41
3.2 Proof of Theorem 3.1.1	42

3.3	Further perspectives	47
4	Green's formula	49
4.1	Introduction	49
4.2	Some general ideas	50
4.3	Some properties of Cauchy-like laws	52
4.4	Computation of the position parameter	55
4.5	Proof of Theorem 4.1.1	57
4.6	Extension to general 1-forms	59
4.7	Relation with Abelian gauge theory	61
II	Liouville area enclosed by curves	65
5	Lévy area for the Liouville measure: existence	67
5.1	Introduction	67
5.2	Three estimates about the Liouville measures	70
5.3	Comparison of $M(\mathcal{D}_N)$ and M_N	74
5.4	Estimation of M_N	80
5.5	Bootstrapping the bounds	83
6	Lévy and Young area for the Liouville measure: path properties	87
6.1	The case of smoother curves	87
6.2	Weak Chen's relation	90
6.3	From weak Chen's relation to pathwise Chen's relation	95
6.4	A Kolmogorov type criterion	98
6.5	Uniform estimates in L^q	104
	References	107

Introduction (en français)

F1 Contenu de la thèse

On s'intéresse dans cette thèse aux points du plan autour desquels le mouvement brownien s'enlace un grand nombre de fois.

Pour une boucle plane Z , c'est à dire une fonction continue de $[0, T]$ dans \mathbb{R}^2 dont les extrémités Z_T et Z_0 coïncident, et pour un point z du plan, hors de l'image de la boucle, on peut définir un entier relatif $\theta(z)$, le nombre de tours de la boucle autour du point z (Figure 1).

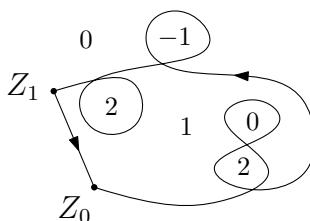

Figure 1: Une courbe $Z : [0, 1] \rightarrow \mathbb{R}^2$, et les différentes valeurs prises par la fonction $\theta : \mathbb{R}^2 \rightarrow \mathbb{R}$ associée.

Si la boucle Z est simple, c'est à dire sans auto-intersection, et suffisamment lisse, on voit facilement que la valeur absolue de l'intégrale de la fonction θ sur \mathbb{R}^2 est égale à l'aire de la composante connexe délimitée par la courbe. Dans ce cas, le théorème de Green affirme que cette aire est elle-même égale à l'intégrale le long de la boucle de la 1-forme différentielle $x dy$. Le même théorème de Green affirme plus généralement qu'on a pour toute 1-forme différentielle lisse η l'égalité

$$\int_Z \eta = \pm \int_{\mathcal{D}_Z} d\eta,$$

où \mathcal{D}_Z désigne la composante connexe bornée délimitée par Z . Le signe dans le terme de droite dépend de l'orientation de la boucle, et est précisément égal à $\theta(z)$, pour n'importe quel point z dans \mathcal{D}_Z .

Autorisons maintenant la boucle Z à se recouper, tout en continuant à la supposer lisse. La fonction θ peut maintenant prendre des valeurs entières autres que -1 , 0 et 1 . Elle peut même ne pas être bornée. Elle est cependant à support compact et, comme nous le verrons, intégrable.

Étant donnée une 1-forme lisse η , la 2-forme $d\eta$ définit sur tout compact de \mathbb{R}^2 , grâce à l'orientation, une mesure signée. Ceci permet de donner un sens au membre de droite de l'égalité

suivante, qui généralise donc dans ce cas la formule de Green :

$$\int_Z \eta = \int_{\mathbb{R}^2} \theta \, d\eta.$$

Autrement dit, la fonction θ contient toute l'information nécessaire pour déterminer les intégrales des formes différentielles lisses le long de la boucle.

Un des buts des travaux présentés dans cette thèse est d'examiner ce qui persiste de cette relation entre nombre de tours et intégrale d'une forme différentielle lorsque la courbe, ou la forme différentielle, est très irrégulière, et éventuellement aléatoire.

Par ailleurs, l'intégrale $\int_{\mathbb{R}^2} \theta \, d\eta$ peut s'estimer par une méthode de Monte-Carlo. Lorsque la mesure signée associée à $d\eta$ est en fait une mesure positive, on peut approcher cette intégrale par l'enlacement moyen des points d'un processus de Poisson \mathcal{P} , d'intensité $\lambda \, d\eta$, où λ est un paramètre positif. En distribution, on a alors

$$\frac{1}{\lambda} \sum_{z \in \mathcal{P}} \theta(z) \xrightarrow{\lambda \rightarrow +\infty} \int_{\mathbb{R}^2} \theta \, d\eta.$$

Il est bien entendu possible d'adapter cette observation au cas où la mesure associée à $d\eta$ n'est pas de signe constant.

L'intégrabilité de la fonction θ , que nous avons mentionnée plus haut, est nécessaire pour que la formule de Green et la méthode de Monte-Carlo fassent sens. En fait, lorsque la courbe Z est de classe \mathcal{C}^1 , cette fonction θ est même de carré intégrable, par exemple en vertu de l'inégalité de Banchoff–Pohl [3], qui généralise l'inégalité isopérimétrique. Nous verrons que θ reste intégrable lorsque Z est seulement de régularité $\mathcal{C}^{\frac{1}{2}+\varepsilon}$, et que la formule de Green reste valide dans ce cas (l'intégrale $\int_Z \eta$ étant alors définie au sens de Young).

Un cas qui nous intéressera beaucoup dans cette thèse est celui où la courbe Z est un mouvement brownien plan, dont on relie les extrémités par un segment droit afin de former une boucle. La figure 2 ci-dessous donne un aperçu de la fonction θ dans ce cas. Bien que cette fonction θ ne soit alors plus intégrable, et l'intégrale de Young plus définie, on verra qu'on peut toujours donner un sens à l'intégrale de θ , et retrouver une formule de Green quand $\int_Z \eta$ est interprétée comme une intégrale de Stratonovich.

De plus, on verra que l'estimation par la méthode de Monte-Carlo reste partiellement valide. Il y a toujours une convergence en distribution (presque sûrement par rapport à la trajectoire brownienne), mais la distribution limite n'est plus une constante : il s'agit d'une loi de Cauchy, dont le paramètre de position est exactement $\int_Z \eta$.

Ces résultats passent très largement par l'étude de l'ensemble

$$\mathcal{D}_N = \{z \in \mathbb{R}^2 : \theta(z) \geq N\}$$

des points autour desquels le mouvement brownien tourne beaucoup. Nous montrerons diverses propriétés asymptotiques de cet ensemble de points, en loi et au sens presque sûr, lorsque N tend vers l'infini. Nous donnerons entre autres choses des résultats sur la répartition spatiale de cet ensemble ainsi que sur son aire pour diverses mesures sur le plan.

En particulier, la seconde partie de cette thèse est consacrée au cas où la mesure d'aire est un chaos multiplicatif gaussien, qui est une mesure aléatoire extrêmement irrégulière. Cela nous permettra, par la formule de Green, de définir des intégrales trajectorielles dans ce cadre.

F2 Une brève histoire des enlacements du mouvement brownien

L'enlacement $\theta(z)$ du mouvement brownien sur $[0, T]$ autour d'un point z a d'abord été étudié en 1958 par F. Spitzer [46], qui a démontré la convergence en loi, lorsque T tend vers l'infini, de $\frac{\theta(z)}{\log(T)}$ vers une loi de Cauchy.

Au début des années 80, M. Yor donne une expression intégrale explicite de la loi de $\theta(z)$, à T fixé, à l'aide de l'invariance conforme du mouvement brownien. La preuve, que l'on trouve aujourd'hui plus facilement dans [37] (en anglais) que dans l'article original [50] (en français), est d'une élégance déconcertante, mais très spécifique au mouvement brownien euclidien. À ce jour, il n'existe à ma connaissance aucune formule similaire plus générale.

On trouve, autour des années 90, de nombreux résultats plus complexes sur le même thème. Ainsi, J.-F. Le Gall et M. Yor ont étudié les enlacements browniens autour de courbes dans l'espace [32, 33], J. Franchi a étudié les enlacements du mouvement brownien sur les surfaces riemanniennes [17, 18], et des propriétés en temps joints ont été démontrées, notamment par J. Bertoin et W. Werner dans [6], et par Z. Shi dans [45].

Tous les résultats cités jusqu'ici concernent l'enlacement autour d'un seul point. En fait, le résultat de F. Spitzer s'étend à l'étude jointe des enlacements $(\theta(z_1), \dots, \theta(z_n))$ autour de plusieurs

Figure 2: Coloration du plan en fonction des valeurs de θ , pour un mouvement brownien.

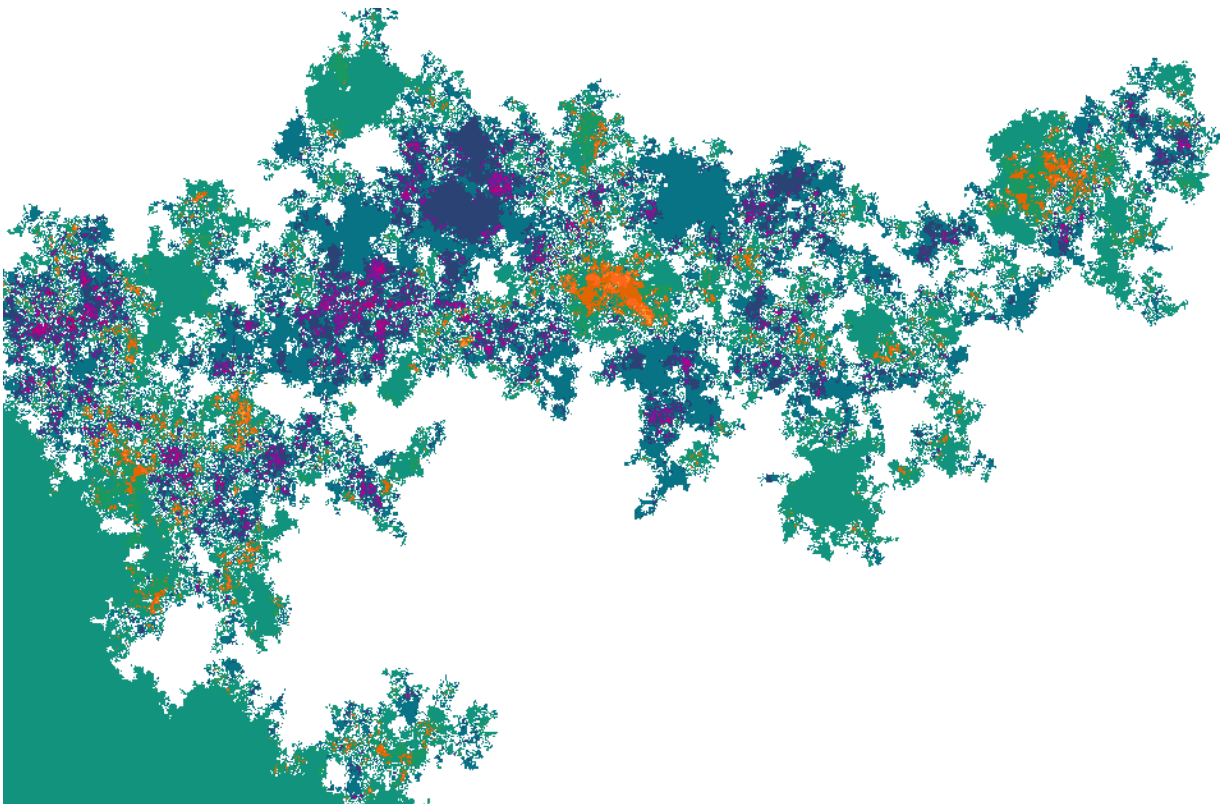

points. On peut alors démontrer que la convergence a lieu vers des variables indépendantes, ce qui s'explique de la manière suivante.

L'enlacement $\theta(z)$ peut se décomposer en deux contributions, l'une provenant des « grands tours », lorsque le mouvement brownien est loin du point z , et l'autre des « petits tours », lorsque le mouvement brownien est proche du point z . Tandis que la loi des petits tours a un comportement proche de celui d'une loi de Cauchy, celle des grands tours a un comportement proche de celui d'une loi de Gauss. Lorsque T est grand, la contribution des grands tours devient négligeable comparativement à celle des petits tours. Pour deux points proches z_1 et z_2 , la contribution des grands tours est similaire (mais négligeable), tandis que les contributions des petits tours autour de z_1 et autour de z_2 sont fortement décorréélées.

Les propriétés de l'enlacement, jointes en espace, mais non asymptotiques en temps, ont été étudiées principalement par W. Werner. Dans les années 90 également, il s'est intéressé, pendant sa thèse, à l'aire de l'ensemble des points dont l'enlacement est donné. Pour un entier N strictement positif (respectivement, strictement négatif), il définit \mathcal{D}_N comme l'ensemble des points du plan pour lesquels $\theta(z)$ est plus grand que N (respectivement, plus petit que N), et \mathcal{A}_N l'ensemble des points du plan pour lesquels $\theta(z)$ vaut exactement N . Il démontre alors dans [47] que la mesure de Lebesgue, notée A_N , de \mathcal{A}_N est équivalente dans L^2 à $\frac{T}{2\pi N^2}$, c'est à dire que

$$\mathbb{E}[(N^2 A_N - \frac{T}{2\pi})^2] \xrightarrow{N \rightarrow +\infty} 0. \quad (1)$$

De même, la mesure de Lebesgue D_N de \mathcal{D}_N est équivalente dans L^2 à $\frac{T}{2\pi N}$:

$$\mathbb{E}[(N D_N - \frac{T}{2\pi})^2] \xrightarrow{N \rightarrow +\infty} 0. \quad (2)$$

Un des principaux leviers techniques de cette thèse consiste à démontrer des versions un peu plus précises de cette dernière convergence : elle a lieu, comme W. Werner l'avait annoncé, dans L^p pour tout $p \leq 1$, mais également au sens presque sûr. Nous étudierons par ailleurs la vitesse à laquelle elle a lieu, et donnerons une estimation du terme d'erreur.

Dans [48], W. Werner étudie encore la fonction d'enlacement du mouvement brownien, et démontre une formule de Green en probabilité. La fonction θ n'est pas intégrable dans ce cas, et définir son intégrale requiert une certaine forme de régularisation. Dans [48], cette régularisation est obtenue en éliminant la contribution des trop petits tours. Pour chaque point z du plan, on peut calculer $\theta_z(t)$, la détermination continue du logarithme le long de la courbe X restreinte à $[0, t]$. En particulier, notre indice $\theta(z)$ est l'entier le plus proche de $\frac{1}{2\pi}\theta_z(1)$.¹ La procédure de régularisation consiste alors à remplacer $\theta_z(1)$ par

$$\int_0^1 \mathbb{1}_{|X_t - z| \geq \varepsilon} d\theta_z(t),$$

en calculant l'intégrale en espace, puis en faisant tendre ε vers 0. Il montre qu'une limite en

¹W. Werner étudie surtout le cas du lacet brownien, de sorte que l'enlacement réel $\theta_z(1)$ et l'enlacement entier $\theta(z)$ coïncident (à un facteur multiplicatif près).

probabilité existe, et vaut l'aire de Lévy²

$$\int_0^T \frac{X_s^1 \circ dX_s^2 - X_s^2 \circ dX_s^1}{2}. \quad (3)$$

Bien que notre approche soit un peu différente sur cette dernière question, ces deux articles ont largement inspiré notre travail.

Du côté de la physique théorique, mentionnons que l'on trouve de nombreux articles, en particulier d'A. Comtet, J. Desbois, S. Ouvry et divers coauteurs, qui considèrent et étudient l'enlacement du mouvement brownien en lien avec des modèles tels que des bosons couplés à un champ magnétique [2], des gaz d'anyons [39] ou encore l'intrication des polymères [11]. Indépendamment, J. H. Hannay a étudié le produit des enlacements joints 'en moyenne' d'un mouvement brownien plan autour de plusieurs points [27], et d'un mouvement brownien spatial autour de plusieurs courbes [26].

Cette brève bibliographie ne prétend évidemment pas à l'exhaustivité et l'auteur présente ses excuses à tous les auteurs de travaux qui auraient dû être cités.

F3 Présentation des résultats et organisation de la thèse

Principe général de la régularisation de l'aire délimitée par le mouvement brownien

Comme nous l'avons expliqué plus haut, un de nos buts principaux dans cette thèse est de donner un sens à l'intégrale de la fonction θ dans des situations où la courbe est trop irrégulière pour que θ soit intégrable au sens de Lebesgue, en particulier dans le cas du mouvement brownien plan, et de manière à ce qu'une formule de Green soit vraie.

Ceci nécessite, comme nous l'avons également déjà mentionné, une procédure de régularisation. Celle que nous adoptons est différente de celle utilisée par W. Werner dans les travaux évoqués dans la section précédente, et nous allons commencer par en décrire le principe. Notons dès maintenant que quelle que soit la régularisation qu'on utilise, elle doit être suivie et levée par un passage à la limite qui n'est possible que parce qu'il y a une très exacte compensation entre les divergences positives et négatives de θ , comme nous allons l'expliquer maintenant.

Adoptons la convention qui consiste à noter $|\mathcal{A}|$ la mesure de Lebesgue d'une partie borélienne \mathcal{A} de \mathbb{R}^2 . Pour toute fonction $f : \mathbb{R}^2 \rightarrow \mathbb{Z}$ intégrable, on a les égalités

$$\int_{\mathbb{R}^2} f(z) dz = \sum_{k \in \mathbb{Z} \setminus \{0\}} k |\{z : f(z) = k\}| = \sum_{k=1}^{+\infty} k \left(|\{z : f(z) = k\}| - |\{z : f(z) = -k\}| \right).$$

La somme à droite est parfois définie même lorsque f n'est pas intégrable, et c'est alors un bon candidat pour définir $\int_{\mathbb{R}^2} f(z) dz$. Dans le cas où $f = \theta$, le k -ième terme dans cette somme n'est

²Dans la formule (3), il faut interpréter l'intégrale au sens de Stratonovich. Dans ce cas précis, cela a peu d'importance et on pourrait également interpréter l'intégrale au sens d'Itô. Ce n'est évidemment plus le cas dès que l'on considère une forme différentielle η plus générale que $\frac{x dy - y dx}{2}$, ou lorsque le mouvement brownien est remplacé par une semimartingale plus générale.

autre que $k(A_k - A_{-k})$. Le résultat de W. Werner ne permet pas de dire si cette quantité est sommable ou non : pour cela, il faudrait contrôler la taille des fluctuations de $k^2 A_k$ autour de sa valeur limite $\frac{1}{2\pi}$.

Cela semble un peu trop ambitieux, en particulier parce qu'il n'y a *a priori* aucun lien particulier entre deux termes successifs A_k et A_{k+1} . En revanche, la suite $(D_n)_{n \in \mathbb{N}}$ a au moins l'avantage d'être monotone, et il est plus raisonnable d'étudier ses fluctuations que celles de la suite $(A_k)_{k \in \mathbb{N}}$. Cela s'avère suffisant pour donner un sens à l'intégrale $\int_{\mathbb{R}^2} \theta(z) dz$, car une formule d'intégration par partie discrète (sommation d'Abel) assure, pour f intégrable, que

$$\sum_{k=1}^{+\infty} k \left(|\{z : f(z) = k\}| - |\{z : f(z) = -k\}| \right) = \sum_{k=1}^{+\infty} \left(|\{z : f(z) \geq k\}| - |\{z : f(z) \leq -k\}| \right).$$

Les deux termes de cette dernière égalité correspondent respectivement aux deux régularisations suivantes :

$$\begin{aligned} \sum_{k=1}^{+\infty} k \left(|\{z : f(z) = k\}| - |\{z : f(z) = -k\}| \right) &= \lim_{N \rightarrow \infty} \int_{\mathbb{R}^2} \mathbb{1}_{\{|f(z)| \leq N\}} f(z) dz, \\ \sum_{n=1}^{+\infty} \left(|\{z : f(z) \geq n\}| - |\{z : f(z) \leq -n\}| \right) &= \lim_{N \rightarrow \infty} \int_{\mathbb{R}^2} \max(-N, \min(f(z), N)) dz. \end{aligned} \quad (4)$$

La deuxième formule, où l'on ne coupe pas brutalement la fonction de N à 0 entre \mathcal{A}_N et \mathcal{A}_{N+1} , correspond à la régularisation que nous utiliserons.³

F3.1 Chapitre 1: le cas de Young

Le chapitre 1 est un peu particulier, en ce qu'il motive en partie le reste de la thèse. C'est dans ce chapitre que l'on étend la formule de Green à des courbes de régularité faible mais suffisante pour que l'intégrale de Young soit bien définie.

Rappelons qu'une fonction continue $g : [0, 1] \rightarrow \mathbb{R}$ est dite à p -variation finie, avec $p \in [1, +\infty)$, si la quantité

$$\|g\|_p^p := \sup_{\mathbf{t}} \sum_{i=1}^n |g(t_i) - g(t_{i-1})|^p$$

est finie, où le supremum est pris sur l'ensemble des dissections

$$\mathbf{t} = (t_0, \dots, t_n) : 0 = t_0 < \dots < t_n = 1$$

de l'intervalle $[0, 1]$.

Lorsque $Y^1 : [0, 1] \rightarrow \mathbb{R}^2$ est à p -variation finie, et $Y^2 : [0, 1] \rightarrow \mathbb{R}^2$ est à q -variation finie, avec $p^{-1} + q^{-1} > 1$, on peut définir l'intégrale de Young de Y^1 contre Y^2 comme la limite de sommes de Riemann :

$$\int_0^1 Y^1 dY^2 = \lim_{|\mathbf{t}| \rightarrow 0} \sum_{i=1}^n Y^1(t_i) (Y^2(t_i) - Y^2(t_{i-1})),$$

³Dans le cas qu'on présente ici, on verra que les deux régularisations donnent en fait la même limite. Dans la suite, on remplacera la mesure de Lebesgue par une mesure très irrégulière, et on ne sait alors pas en dire autant.

où $|\mathbf{t}| = \max_{i \in \{1, \dots, n\}} |t_i - t_{i-1}|$ désigne le pas de la dissection \mathbf{t} .

On peut ensuite définir l'intégrale de n'importe quelle 1-forme différentielle lisse sur le plan, le long de la courbe Y , à condition que p et q soient chacun plus petit que 2.

Sous les mêmes conditions, on montre que la fonction d'enlacement de la courbe $Y = (Y^1, Y^2)$ est intégrable, et qu'on a une formule de Green.

Théorème 1. *Soit $p, q > 1$ tels que $\delta = p^{-1} + q^{-1} - 1 > 0$. Soient $Y^1 : [0, 1] \rightarrow \mathbb{R}$ à p -variation finie, et $Y^2 : [0, 1] \rightarrow \mathbb{R}$ à q -variation finie. Alors, la fonction d'enlacement θ de la courbe $Y = (Y^1, Y^2)$ fermée par un segment de droite appartient à $L^{1+\delta'}(\mathbb{R}^2)$ pour tout $\delta' < \delta$. Alors,*

$$\int_{\mathbb{R}^2} \theta \, dz = \frac{1}{2} \left(\int Y^1 \, dY^2 - \int Y^2 \, dY^1 \right).$$

De plus, si $p, q < 2$, alors pour toute 1-forme lisse η ,

$$\int_{\mathbb{R}^2} \theta \, d\eta = \int_Y \eta.$$

F3.2 Chapitre 2 : étude asymptotique des aires de grands enlacements du mouvement brownien

Dans ce chapitre, on démontre que la convergence (2) a également lieu dans L^p pour tout p , ainsi qu'au sens presque sûr. On donne également une borne sur la vitesse de convergence dans chacun de ces espaces, ainsi que des bornes sur l'aire de l'ensemble des points où deux mouvements browniens s'enlacent beaucoup.

Ce chapitre est le plus technique, et les résultats qu'il contient sont utilisés dans tous le reste du manuscrit. C'est aussi le chapitre dans lequel on introduit la technique qu'on appelle *bootstrap*, qu'on utilisera pour démontrer plusieurs autres résultats. Le résultat principal de ce chapitre est le résultat suivant.

Théorème 2. *Pour tout $\varepsilon > 0$ et tout $p \in [1, +\infty)$, il existe $C > 0$ tel que pour tout entier N ,*

$$\mathbb{E} \left[\left| ND_N - \frac{1}{2\pi} \right|^p \right]^{\frac{1}{p}} \leq CN^{-\frac{1}{2} + \varepsilon}. \quad (5)$$

De plus, pour tout $\varepsilon > 0$, presque sûrement, il existe C tel que pour tout N ,

$$\left| ND_N - \frac{1}{2\pi} \right| \leq CN^{-\frac{1}{2} + \varepsilon}. \quad (6)$$

En particulier, on peut déduire de ce résultat que la limite (4) existe, au sens presque sûr et au sens L^p pour tout $p < +\infty$, lorsque f est la fonction d'enlacement du mouvement brownien plan.

Bien que l'exposant $\frac{1}{2}$ apparaisse comme une limite technique dans notre preuve, nous donnons un argument heuristique qui nous laisse penser que cette exposant est optimal, au sens suivant.

Conjecture 3. *Il n'existe pas de fonction déterministe h et d'exposant $\varepsilon > 0$ tels que presque sûrement, il existe C tel que pour tout N ,*

$$|ND_N - h(N)| \leq CN^{-\frac{1}{2} - \varepsilon}.$$

Remarquons simplement que cette conjecture, si elle est vraie, n'empêche pas $N(D_N - D_{-N})$ d'avoir un ordre asymptotique plus petit.

Ce théorème est complété par l'étude de l'aire de l'ensemble des points autour desquels deux mouvements browniens s'enlacent beaucoup. Cette étude est également assez technique, mais la proposition 2.2.10 est écrite de manière à être lisible directement.

F3.3 Chapitre 3 : étude asymptotique des ensembles de grands enlacements

Dans le chapitre 3, on démontre que la mesure aléatoire $N\mathbb{1}_{\mathcal{D}_N} dz$ converge presque sûrement, faiblement, vers la mesure d'occupation du mouvement brownien plan. Ce résultat est en quelque sorte la cristallisation de l'idée qui sous-tend le bootstrap, et selon laquelle l'ensemble \mathcal{D}_N , pour N grand, est très proche de la trajectoire de X , mais également très bien réparti le long de cette trajectoire.

Théorème 4. *La mesure $N\mathbb{1}_{\mathcal{D}_N} dz$ converge presque sûrement, faiblement, vers la mesure d'occupation du mouvement brownien.*

On utilisera ce résultat de manière marginale, dans la section 4.6 uniquement.

F3.4 Chapitre 4 : formule de Green

Dans le chapitre 4, on établit une formule de Green pour le mouvement brownien, avec une convergence presque sûre. Comme expliqué précédemment, la procédure de régularisation est différente de celle de W. Werner : on coupe simplement la fonction d'enlacement θ lorsqu'elle prend de trop grandes valeurs (en valeur absolue).

Théorème 5. *La somme*

$$\sum_{N=1}^{N_0} (D_N - D_{-N}) = \int_{\mathbb{R}^2} \max(-N_0, \min(\theta(z), N_0)) dz$$

converge, presque sûrement et dans L^p pour tout $p \in [1, +\infty)$, lorsque $N_0 \rightarrow +\infty$, vers l'aire de Lévy (3).

On démontre également le résultat qui suit, et dans lequel ressort le comportement de Cauchy qui apparaît dans le théorème de Spitzer. Heuristiquement, ce résultat indique que l'enlacement du mouvement Brownien autour d'un point choisi au hasard se comporte comme une loi de Cauchy. La différence majeure avec le théorème de Spitzer est que la trajectoire brownienne est ici fixée. En particulier, la loi de l'enlacement θ n'est plus 'centrée' autour de 0, mais autour de l'aire de Lévy du mouvement brownien.

Théorème 6. *Soit $X : [0, 1] \rightarrow \mathbb{R}^2$ un mouvement brownien, défini sur un espace de probabilité $(\Omega^X, \mathcal{F}^X, \mathbb{P}^X)$. Pour tout réel positif K , soit par ailleurs \mathcal{P}_K un processus de Poisson d'intensité $K dz$ sur \mathbb{R}^2 , défini sur un autre espace de probabilité. Alors, \mathbb{P}^X -presque sûrement, la somme*

$$\frac{1}{K} \sum_{z \in \mathcal{P}_K} \theta(z)$$

converge en distribution, lorsque $K \rightarrow +\infty$, vers une variable de Cauchy dont le paramètre de position est l'aire de Lévy (3).

Cette loi de Cauchy nous semble mieux décrire certaines situations physiques que la seule aire de Lévy, par exemple lorsque l'on considère le champ magnétique engendré par des dipôles distribués aléatoirement. Ce résultat prédit alors un phénomène de non-convergence vers la 'valeur moyenne', et nous paraît être le plus important de la thèse du point de vue applicatif.

F3.5 Chapitre 5 : aire de Liouville enlacée par un mouvement brownien

Dans le chapitre 5, on s'intéresse comme dans les chapitres précédents à l'aire délimitée par le mouvement brownien, mais maintenant avec un chaos multiplicatif gaussien comme mesure d'aire remplaçant la mesure de Lebesgue.

Un chaos multiplicatif gaussien \mathbb{M} est une mesure aléatoire qui peut être décrite informellement par la formule

$$\mathbb{M}(dz) = e^{\gamma\Phi_z - \frac{\gamma^2}{2}\mathbb{E}[\Phi_z^2]} dz$$

où Φ est un champ aléatoire gaussien centré, dont le noyau de covariance K admet une divergence logarithmique près de la diagonale, au sens où $K(z, w) = \log_+(|z - w|^{-1}) + g(z, w)$, pour une certaine fonction g continue sur $\mathbb{R}^2 \times \mathbb{R}^2$. Typiquement, Φ est un champ gaussien libre.

Pour un tel noyau, Φ n'est défini qu'en tant que distribution aléatoire, et la formule précédente pour \mathbb{M} n'a pas de sens immédiat. Depuis les travaux de J.-P. Kahane [29], on sait cependant définir une telle mesure en toute rigueur, lorsque le paramètre d'intermittence γ appartient à $[0, 2)$.⁴

Il est connu que la mesure \mathbb{M} est bien plus facile à définir et à étudier lorsque $\gamma < \sqrt{2}$. La raison en est que la quantité $\mathbb{M}(A)$ admet alors un moment d'ordre 2 fini pour tout borélien A de mesure de Lebesgue finie, ce qui permet d'utiliser certain résultat associé aux espaces hilbertien et aux martingales L^2 . Le résultat principal de ce chapitre montre qu'il est possible, sous la condition plus restrictive $\gamma < \sqrt{4/3}$, de définir la \mathbb{M} -aire délimitée par la courbe brownienne.

On supposera que la mesure \mathbb{M} est définie sur un espace de probabilité $(\Omega^{\mathbb{M}}, \mathcal{F}^{\mathbb{M}}, \mathbb{P}^{\mathbb{M}})$, tandis que le mouvement brownien X est défini sur un second espace de probabilité noté $(\Omega^X, \mathcal{F}^X, \mathbb{P}^X)$.

Théorème 7. Soit $\gamma < \sqrt{4/3}$ et $p \in [1, \frac{4}{\gamma^2})$. Pour tout $s < t \in [0, 1]$, la quantité

$$\int_{\mathbb{R}^2} \max(-N_0, \min(\theta_{X_{|[s,t]}}(z), N_0)) d\mathbb{M}(z)$$

converge dans $L^p(\Omega^X, L^2(\Omega^{\mathbb{M}}))$ lorsque $N_0 \rightarrow +\infty$, vers une limite $\mathbb{A}_{s,t}$. En particulier, la convergence a lieu dans $L^2(\Omega^X \times \Omega^{\mathbb{M}})$.

F3.6 Chapitre 6 : propriétés trajectorielles de l'aire de Liouville enlacée par une courbe

Dans le chapitre 6, on commence par définir l'aire délimitée par une courbe plus lisse qu'un mouvement brownien, avec pour mesure d'aire un chaos multiplicatif gaussien. On s'intéresse

⁴On sait en fait définir une telle mesure également lorsque $\gamma = 2$ avec une normalisation supplémentaire, et également pour $\gamma > 2$, mais les constructions sont différentes et le comportement des mesures relativement différent.

ensuite aux propriétés de la fonction qui à s et t associe l'aire enlacée par la courbe restreinte à l'intervalle $[s, t]$, dans le cas d'une courbe brownienne ou d'une courbe plus lisse. Comme d'habitude, cette courbe est fermée par un segment de droite si ses extrémités sont distinctes.

On démontre l'existence d'une relation de Chen (ou disons, d'une relation de Chasles). Sous la mesure d'aire \mathbb{M} , en notant $\mathbb{A}_{s,t}$ l'aire délimitée par la portion de courbe entre s et t , et $T_{s,u,t}$ l'enveloppe convexe des points X_s , X_u , et X_t , une telle relation s'écrit

$$\mathbb{A}_{s,t} = \mathbb{A}_{s,u} + \mathbb{A}_{u,t} + \varepsilon_{s,u,t} \mathbb{M}(T_{s,u,t}), \quad (7)$$

avec $\varepsilon_{s,u,t} \in \{-1, 1\}$. Une telle propriété est en un certain sens la seule propriété attendue d'une famille $(\mathbb{A}_{s,t})_{s < t \in [0,1]}$ pour qu'elle mérite d'être appelée *aire enclose par la courbe* $X_{[s,t]}$ (pour la mesure d'aire \mathbb{M}).

On démontre également des résultats de régularité (continuité et régularité au sens de Hölder) de la fonction d'aire.

Dans le cas euclidien, c'est à dire lorsque la mesure d'aire est la mesure de Lebesgue, ces deux propriétés (relation de Chen et régularité) découlaient automatiquement de la formule de Green, et des résultats classiques sur l'intégrale de Young et l'intégrale stochastique.

Théorème 8 (Cas du mouvement Brownien). *Soit $\gamma < \sqrt{4/3} \simeq 1.15\dots$ et $p \in [1, \frac{4}{\gamma^2})$.*

- ◊ *Pour tous réels $s < u < t$, $\mathbb{P}^X \otimes \mathbb{P}^M$ presque sûrement, la relation (7) est satisfaite. La collection de variables aléatoires $\mathbb{A} = (\mathbb{A}_{s,t})_{s < t}$ admet une version qui satisfait (7) pour tous s , u , et t .*
- ◊ *Si de plus $\gamma < 2(\sqrt{2}-1) \simeq 0.82\dots$, la collection de variables aléatoires $\mathbb{A} = (\mathbb{A}_{s,t})_{s < t}$ admet une version continue, qui satisfait encore (7) pour tout s , u , et t . Cette version est alors β -Hölder continue, en tant que fonction de deux variables, pour β suffisamment petit.*

Dans [22], et simultanément dans [4], les auteurs parviennent à définir un mouvement brownien de Liouville \mathcal{X} , associé à la mesure \mathbb{M} , dont la trajectoire est celle d'un mouvement brownien usuel, parcouru jusqu'à un temps aléatoire. Lorsque $\gamma < 2(\sqrt{2}-1)$, la modification continue de \mathbb{A} est définie pour tout t , et cela permet également de définir l'aire enclose par la courbe \mathcal{X} .

Théorème 9 (Cas des courbes plus régulières). *Soient $\alpha > \frac{1}{2}$, $\gamma < 2$, et $Y = (Y^1, Y^2)$ une fonction α -Hölder continue. Soit $\theta_{s,t}^Y$ la fonction d'enlacement de $Y_{[s,t]}$.*

- ◊ *Pour tout $s < t \in [0, 1]$, \mathbb{P}^M -presque sûrement, $\theta_{s,t}^Y \in L^1(\mathbb{R}^2, \mathbb{M})$, et*

$$\mathbb{A}_{s,t}^Y := \int_{\mathbb{R}^2} \theta_{s,t}^Y \, d\mathbb{M} \quad \text{appartient à } L^1(\Omega^M).$$

- ◊ *Pour tout $s < u < t$, \mathbb{P}^M presque sûrement, la relation (7) est satisfaite. La collection de variables aléatoires $\mathbb{A}^Y = (\mathbb{A}_{s,t}^Y)_{s < t}$ admet une version qui satisfait (7) pour tout s , u , et t .*
- ◊ *Si de plus $\gamma < \sqrt{2}$ et $\alpha > \frac{1}{2}(1 - \frac{\gamma^2}{4})^{-1}$, la collection de variables aléatoires $\mathbb{A} = (\mathbb{A}_{s,t})_{s < t}$ admet une version continue, qui satisfait encore (7) pour tout s , u , et t . Cette version est alors β -Hölder continue, en tant que fonction de deux variables, pour β suffisamment petit.*

Pour ces deux théorèmes, on donne également des bornes explicites sur les valeurs possibles de β , en fonction de γ et α . On n'attend cependant pas de ces bornes explicites qu'elles soient optimales. En particulier, on se repose sur une variation autour du théorème de Kolmogorov, qui nous semble mieux adapté à un contexte monofractal qu'au contexte multifractal des chaos multiplicatifs gaussiens.

Les chapitres 1, 2 et 4, dans lesquels on montre les théorèmes 1, 2, 5 et 6, sont essentiellement issus de la prépublication [43]. On a décidé d'intercaler le chapitre 3, qui correspond à la prépublication [44], et dans lequel on démontre le théorème 4. Il nous a semblé en effet qu'il était pertinent de montrer ce résultat le plus tôt possible dans la thèse, car il participe largement de notre intuition de l'ensemble \mathcal{D}_N , et aussi parce qu'il permet de démontrer les résultats de la section 4.6, qui ne sont inclus dans aucune prépublication. Les théorèmes 7, 8 et 9 correspondent à la prépublication [42].

F3.7 L'idée clé de notre étude des enlacements d'un mouvement brownien

La majorité de la thèse repose sur une idée simple que l'on illustre ici dans le cadre du théorème 2. Lorsque N est grand, l'ensemble \mathcal{D}_N est très proche de la trajectoire, et extrêmement bien réparti le long de cette trajectoire.⁵ De plus, pour quasiment tous les points de cet ensemble, la majeure partie de l'enlacement est seulement due à une petite portion de la trajectoire.

Concrètement, cela veut dire que l'on devrait pouvoir découper la courbe en T morceaux, et étudier l'ensemble de grand enlacement de chacun de ces T morceaux de courbe, plutôt que d'étudier directement l'ensemble de grand enlacement initial. En notant \mathcal{D}_N^i l'ensemble de grand enlacement du i -ème morceau, et D_N^i sa mesure de Lebesgue, on a approximativement

$$\mathcal{D}_N \simeq \bigsqcup_{i=1}^T \mathcal{D}_N^i \quad \text{et} \quad D_N \simeq \sum_{i=1}^T D_N^i. \quad (8)$$

L'autosimilarité et la propriété de Markov du mouvement brownien nous permettent ensuite de décrire les D_N^i comme des variables aléatoires indépendantes, dont la loi est celle de D_N , à un facteur d'échelle près.

On a alors une certaine forme de concentration : comme les fluctuations de chacun des D_N^i se compensent stochastiquement, la fluctuation de D_N ne peut être trop grande. En fait, on compare la fluctuation de D_N à elle-même, plus un terme d'erreur provenant de l'approximation (8).

On peut grossièrement décomposer la partie technique de cette idée en deux étapes.

- ◊ D'une part, il faut donner un sens à l'équation informelle (8) : on a en fait un encadrement de \mathcal{D}_N entre deux ensembles qui sont chacun "presque" le membre de droite de l'équation (8). Il y a évidemment des termes supplémentaires qu'il est nécessaire de contrôler.
- ◊ D'autre part, il faut comprendre comment cette relation d'autosimilarité permet effectivement de contrôler les fluctuations de \mathcal{D}_N : il s'agit en fait de mettre en place une récurrence, relativement simple a posteriori.

⁵Cette première partie de l'idée se concrétise formellement dans le théorème 4.

Cette idée repose principalement sur le comportement fractal du mouvement brownien, et il est possible qu'elle permette d'étudier également les enlacements d'autres type de courbes fractales – et notamment du mouvement brownien fractionnaire plan. Dans la pratique, elle demande cependant d'avoir déjà connaissance d'une asymptotique au premier ordre pour les valeurs D_N associées à la courbe.

Introduction (in English)

E1 Content of the thesis

This thesis is concerned with the points on the plane around which the Brownian motion winds a large number of times.

For a planar loop Z , that is a continuous function from $[0, T]$ to \mathbb{R}^2 whose endpoints Z_T and Z_0 are equal, we can define a relative integer $\theta(z)$, the winding number of the loop around a point z on the plane, but outside the range of the loop (Figure 1).

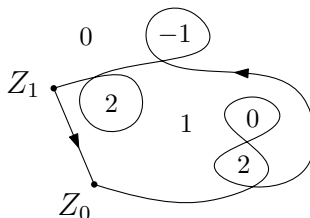

Figure 1: A curve $Z : [0, 1] \rightarrow \mathbb{R}^2$, and the different values of the associated function $\theta : \mathbb{R}^2 \rightarrow \mathbb{R}$.

If the loop Z is simple, that is with no self-intersection, and sufficiently smooth, it can be seen that the absolute value of the integral of θ on \mathbb{R}^2 is equal to the area of the connected component delimited by the loop. In this case, the Green's theorem states that this area itself is equal to the integral along the loop of the differential 1-form $x dy$. More generally, the Green's theorem states that for any smooth 1-form η ,

$$\int_Z \eta = \pm \int_{\mathcal{D}_Z} d\eta,$$

where \mathcal{D}_Z is the bounded connected component delimited by Z . The sign in the right-hand side of this equality depends on the orientation of the loop, and it is precisely equal to $\theta(z)$, for any point z inside \mathcal{D}_Z .

If the loop is still assumed to be smooth, but is now allowed to have self-intersections, the function θ is not restricted anymore to the three possible values -1 , 0 , and 1 . It may even be unbounded. Nonetheless, it always has a compact support, and we will see that it always integrable.

Given a smooth 1-form η , the 2-form $d\eta$ defines on any compact set of \mathbb{R}^2 , thanks to the orientation, a signed measure. This allows us to define the right-hand side of the following equality, which is a generalization of the Green's theorem.

$$\int_Z \eta = \int_{\mathbb{R}^2} \theta \, d\eta.$$

This implies that θ , the winding function, carries all the information needed to determine the integral of any smooth differential form along the loop.

One of the goals of the work presented in this thesis is to study what remains from this relation between winding number and integrals of differential forms when the loop, or the differential form, is very irregular, and possibly random.

Besides, the integral $\int_{\mathbb{R}^2} \theta \, d\eta$ can be estimated by a Monte-Carlo method. When the signed measure associated with $d\eta$ is actually a positive measure, we can approach this integral by the average winding of the points of a Poisson process \mathcal{P} with intensity $\lambda \, d\eta$, with λ a large positive parameter. In distribution,

$$\frac{1}{\lambda} \sum_{z \in \mathcal{P}} \theta(z) \xrightarrow{\lambda \rightarrow +\infty} \int_{\mathbb{R}^2} \theta \, d\eta.$$

We can of course adapt this to the case when the associated measure $d\eta$ is not assumed to be positive.

The integrability of the function θ , that we already mentioned, is necessary for both the Green's formula and the Monte-Carlo method to make any sense at all. When the loop Z is \mathcal{C}^1 , this function θ is actually square-integrable, as it follows for example from the Banchoff-Pohl inequality [3], which generalizes the isoperimetric inequality. We will see that θ remains integrable when Z is only assumed to have regularity $\mathcal{C}^{\frac{1}{2}+\varepsilon}$, and that the Green's formula then remains valid –provided that the integral $\int_Z \eta$ is interpreted as a Young integral.

The most important case in this thesis is the one when the curve Z is a planar Brownian motion, whose endpoints are joined together with a straight line segment to form a loop. The figure 2 below gives an idea of the function θ in this case. Even though this function θ is not integrable anymore in this case, and the Young integral not defined anymore, we will see that it is still possible to give a meaning to the integral of θ , and to obtain a Green's formula –provided that $\int_Z \eta$ is understood as a Stratonovich integral.

We will also show that the estimation by the Monte-Carlo method remains somewhat possible. A convergence in distribution still holds, almost surely on the Brownian trajectory, but the limiting distribution is not a constant anymore: instead, it is a Cauchy distribution whose position's parameter is $\int_Z \eta$.

These results follow from the study of the set

$$\mathcal{D}_N = \{z \in \mathbb{R}^2 : \theta(z) \geq N\}$$

of the points around which the Brownian motion winds a lot of time. We will show some asymptotic properties of this set of points, in distribution and in the almost sure sense, as N goes to infinity. Among different things, we will prove some results about the distribution of this set over the plane, and about its area for various measures on the plane.

In particular, the second part of the thesis is devoted to the case when the area measure is a Gaussian multiplicative chaos, which is an highly irregular random measure. Through the Green's formula, this will allow us to define trajectorial integrals in this framework.

E2 A short story of the Brownian windings

The winding $\theta(z)$ of the Brownian motion on $[0, T]$ around a point z has first been studied in 1958 by F. Spitzer [46], who has proved the convergence in distribution of $\frac{\theta(z)}{\log(T)}$, as T goes to infinity, toward a Cauchy distribution.

At the beginning of the 80's, M. Yor gives an explicit formula for the law of $\theta(z)$, when T is fixed. The proof, which can be found more easily in [37] (in English) than in the original article [50] (in French), is astonishingly beautiful, but very specific to the case of the Euclidean Brownian motion. As of today, there doesn't exist to my knowledge any similar formula in a more general framework.

Many more results has been proved around the 90's. The geometrical framework as been extended, with J.-F. Le Gall and M. Yor studying the winding of the three dimensional Brow-

Figure 2: Coloration of the plane depending on the values of θ , when the underlying curve is a Brownian motion.

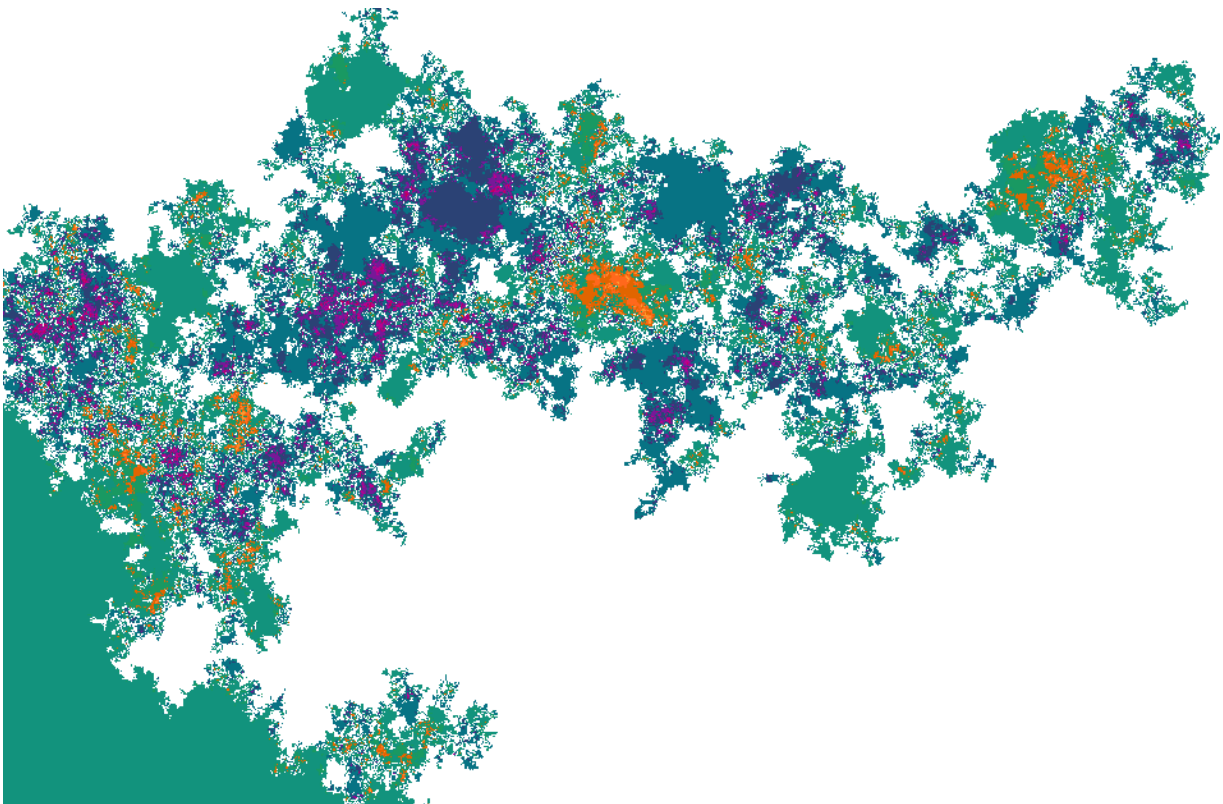

nian motion around curves [32, 33], and J. Franchi studying the winding in a two dimensional Riemannian (and in particular, hyperbolic) framework [17, 18]. Many time-joint properties has also been proved, notoriously by J. Bertoin and W. Werner in [6], and by Z. Shi in [45].

Yet, all the results we mentioned up to here focus on the winding around a single point. Actually, the result of F. Spitzer can be extended to the study of a family $(\theta(z_1), \dots, \theta(z_n))$ of winding around different points. One can then show that the converge still hold, toward independant Cauchy variables.

This can be explained as follows. The winding $\theta(z)$ around a given point z can be splitted into two parts, one coming from the “large turns”, when the Brownian motion is far the point z , and the other coming from the “small turns”, when the Brownian motion is on the contrary very close from the point z . The one coming from small turns behaves as a Cauchy distribution, whilst the one coming from the large turns behave as a Gaussian distribution. When T is large, this last contribution can be neglected compared to the one of the small turns. For two different points z_1, z_2 , the contributions from the large turns is roughly similar, but negligible anyway. On the opposite, the contribution of the small turns around z_1 is almost independent from the contribution of the small turns around z_2 .

Joint in space but non-asymptotic in time properties of the winding function has been studied by W. Werner, during the 90’s. During his PhD, he looked at the area of the set of points with given winding. For a positive (respectively, negative) integer N , he defines the set \mathcal{D}_N of points in the plan for which the winding is at least N (respectively, less than N), and the set \mathcal{A}_N of points with winding exactly N . In [47], he proves that the Lebesgue measure $A_N = |\mathcal{A}_N|$ of the set \mathcal{A}_N is equivalent in L^2 to $\frac{T}{2\pi N^2}$. That is,

$$\mathbb{E}[(N^2 A_N - \frac{T}{2\pi})^2] \xrightarrow{N \rightarrow +\infty} 0. \quad (1)$$

As well, the measure D_N of \mathcal{D}_N is equivalent in L^2 to $\frac{T}{2\pi N}$:

$$\mathbb{E}[(N D_N - \frac{T}{2\pi})^2] \xrightarrow{N \rightarrow +\infty} 0. \quad (2)$$

One of the most technical aspects of this thesis is to show some improved versions of this last convergence: not only does it hold in L^2 , but also in L^p for all p (as it was claimed by W. Werner), and in the almost sure sense. Besides, we will study the convergence rate, and give an estimation of the error term.

In [48], W. Werner continues to study this winding function, and proves a Green’s formula in probability. Since the function θ is not integrable, defining its ‘integral’ requires some regularization procedure. In [48], this regularization is obtained by elimination of the small turns contribution. For each point z on the plane, we can define a $\theta_z = \theta_z(t)$ which is the continuous determination of the logarithm along the curve X restricted to $[0, t]$. In particular, our winding function $\theta(z)$ is the integer value which is the closest one from $\frac{1}{2\pi}\theta_z(1)$.⁶ Then, the regularization procedure is all about replacing $\theta_z(1)$ with

$$\int_0^1 \mathbb{1}_{|X_t - z| \geq \varepsilon} d\theta_z(t),$$

⁶W. Werner mostly studies the case of a Brownian bridge, so that the real-valued winding $\theta_z(1)$ and the integer-valued winding $\theta(z)$ agree, up to a multiplicative factor.

then computing the integral in space, and then letting ε goes to 0. He shows that a limit in probably exists, and that it is indeed equal to the Lévy area⁷

$$\int_0^T \frac{X_s^1 \circ dX_s^2 - X_s^2 \circ dX_s^1}{2}. \tag{3}$$

Although our approach is slightly different on this last question, these two papers has been an important inspiration for our work.

On the side of theoretical physics, let us mention that numerous papers on the subject has been written by A. Comtet, J. Desbois, S. Ouvry, and some of there coauthors. They relate this winding of the Brownian motion with diverse models, such as coupling between bosons and a magnetic field [2], anyons gas [39], or polymer entanglement [11]. Independently, J. H. Hannay has studied the average product of the windings around different points [27] or curves [26], and related it with optical models [25].

Of course, this short bibliography does not pretend to exhaustiveness, and the author would like to apologise for all the authors and works that should have been cited.

E3 Presentation of the results and organisation of the thesis

General principle of the regularization for the area enclosed by the Brownian motion

As we explained already, one of our main goals in this thesis is to give a meaning to the integral of θ , in situations when the curve is not regular enough for θ to be Lebesgue integrable, and in particular in the case of a planar Brownian motion, and in a way such that the Green’s formula remains true.

This requires, as we already stated, some regularization scheme. The one we use is not the one introduced by W.Werner and that we have already presented, and we now describe its principle. Let us remark right now that any such regularization scheme must be lifted by passing to some limit, which is possible only because there is some exact compensation between positive and negative divergences of θ , as we will now explain.

Let us conventionally write $|\mathcal{A}|$ for the Lebesgue measure of a Borel subset \mathcal{A} of \mathbb{R}^2 . For any integrable function $f : \mathbb{R}^2 \rightarrow \mathbb{Z}$, we have the equalities

$$\int_{\mathbb{R}^2} f(z) dz = \sum_{k \in \mathbb{Z} \setminus \{0\}} k |\{z : f(z) = k\}| = \sum_{k=1}^{+\infty} k \left(|\{z : f(z) = k\}| - |\{z : f(z) = -k\}| \right).$$

The sum on the right-hand side might still be well-defined when f is not integrable anymore, and is then a good candidate for the notation $\int_{\mathbb{R}^2} f(z) dz$. When $f = \theta$ the k^{th} term in this sum is nothing but $k(A_k - A_{-k})$. The convergence result given by W. Werner does not allow to

⁷In the formula (3), the integral has to be interpreted in the sense of Stratonovich. In this precise case, it does not really matter and the integral can as well be interpreted as an Itô one. Yet, this is not the case anymore when we consider a differential form η other than $\frac{x dy - y dx}{2}$, or when the Brownian motion is replaced with a more general semimartingale.

say whether this quantity is summable or not: to determine this, we would need to control the magnitude of the fluctuations of $k^2 A_k$ around its limiting value $\frac{1}{2\pi}$.

This seems a bit too ambitious, in particular because there does not seem to be any specific relation between A_k and A_{k+1} . On the opposite, the sequence $(D_n)_{n \in \mathbb{N}}$ has at least the advantage of being monotonic, and it seems more reasonable to study its fluctuations than the ones of the A_n . This happens to be sufficient to give a reasonable meaning to the integral $\int_{\mathbb{R}^2} \theta(z) dz$, since a discrete integration by part (Abel's summation formula) ensures, when f is integrable, the equality

$$\sum_{k=1}^{+\infty} k \left(|\{z : f(z) = k\}| - |\{z : f(z) = -k\}| \right) = \sum_{k=1}^{+\infty} \left(|\{z : f(z) \geq k\}| - |\{z : f(z) \leq -k\}| \right).$$

The two sides of this equality corresponds respectively to the two following regularization scheme:

$$\begin{aligned} \sum_{k=1}^{+\infty} k \left(|\{z : f(z) = k\}| - |\{z : f(z) = -k\}| \right) &= \lim_{N \rightarrow \infty} \int_{\mathbb{R}^2} \mathbb{1}_{\{|f(z)| \leq N\}} f(z) dz, \\ \sum_{n=1}^{+\infty} \left(|\{z : f(z) \geq n\}| - |\{z : f(z) \leq -n\}| \right) &= \lim_{N \rightarrow \infty} \int_{\mathbb{R}^2} \max(-N, \min(f(z), N)) dz. \end{aligned} \quad (4)$$

The second formula, on which we do not sharply cut the function from N to 0 between \mathcal{A}_N and \mathcal{A}_{N+1} , corresponds to the regularization scheme that we will use.⁸

E3.1 Chapter 1: the Young case

The first chapter is a bit particular, in the sense that it partly motivates the thesis. It is in this chapter that we will extend the Green's formula to curves with regularity low, but sufficient for the Young integral to be well-defined.

Let us recall that a continuous function $g : [0, 1] \rightarrow \mathbb{R}$ is said to have finite p -variation, with $p \in [1, +\infty)$, when the quantity

$$\|g\|_p^p := \sup_{\mathbf{t}} \sum_{i=1}^n |g(t_i) - g(t_{i-1})|^p$$

is finite, where the supremum is taken on the set of dissections

$$\mathbf{t} = (t_0, \dots, t_n) : 0 = t_0 < \dots < t_n = 1$$

of $[0, 1]$.

⁸In the case presented here, we will see that these two different regularizations scheme actually happen to lead to the same answer. Nonetheless, we do not know if this remains true when the Lebesgue measure is replaced with an highly irregular measure, as it will be the case in the second part of the thesis.

When $Y^1 : [0, 1] \rightarrow \mathbb{R}^2$ has finite p -variation and $Y^2 : [0, 1] \rightarrow \mathbb{R}^2$ has finite q -variation, with $p^{-1} + q^{-1} > 1$, one can define the Young integral of Y^1 against Y^2 , as the limit of some Riemann sums:

$$\int_0^1 Y^1 \, dY^2 = \lim_{|\mathbf{t}| \rightarrow 0} \sum_{i=1}^n Y^1(t_i)(Y^2(t_i) - Y^2(t_{i-1})),$$

where $|\mathbf{t}| = \max_{i \in \{1, \dots, n\}} |t_i - t_{i-1}|$ is the mesh of the dissection \mathbf{t} .

One can then define the integral of any smooth differential 1-form on the plane along the curve $Y = (Y^1, Y^2)$, provided both p and q are smaller than 2.

Under the same conditions, we will show that the winding function of Y is integrable, and that we have a Green's formula.

Theorem 1. *Let $p, q > 1$ be such that $\delta = p^{-1} + q^{-1} - 1 > 0$. Let $Y^1 : [0, 1] \rightarrow \mathbb{R}$ with p -variation, and $Y^2 : [0, 1] \rightarrow \mathbb{R}$ with finite q -variation. Then, the winding function θ of the curve $Y = (Y^1, Y^2)$, closed by a straight segment, lies in $L^{1+\delta'}(\mathbb{R}^2)$ for all $\delta' < \delta$. Then,*

$$\int_{\mathbb{R}^2} \theta \, dz = \frac{1}{2} \left(\int Y^1 \, dY^2 - \int Y^2 \, dY^1 \right).$$

Besides, if $p, q < 2$, then for all smooth 1-form η ,

$$\int_{\mathbb{R}^2} \theta \, d\eta = \int_Y \eta.$$

E3.2 Chapter 2: asymptotic study of the large winding area of the Brownian motion

In this chapter, we prove that the convergence (2) also holds in L^p for all p , and also in the almost sure sense. We give a bound on the convergence rate, in all these spaces. We also give a bound on the area of the set of points around which two independent Brownian motion both winds a large number of time.

This chapter is the most technical, and the results it contains are used in all the following chapters. It is also in this chapter that we introduce the method that we call the *bootstrap*, and that we will use to prove many other results. The main result of this chapter is the following.

Theorem 2. *For all $\varepsilon > 0$ and $p \in [1, +\infty)$, there exists $C > 0$ such that for all integer N ,*

$$\mathbb{E}[|ND_N - \frac{1}{2\pi}|^p]^{\frac{1}{p}} \leq CN^{-\frac{1}{2}+\varepsilon}. \tag{5}$$

Besides, for all $\varepsilon > 0$, almost surely, there exists C such that for all N ,

$$|ND_N - \frac{1}{2\pi}| \leq CN^{-\frac{1}{2}+\varepsilon}. \tag{6}$$

In particular, we can deduce from this result that the limit (4) exists, both in the almost sure sense and in the L^p sense, for all $p \in [1, +\infty)$, when f is the winding function of the planar Brownian motion.

Even though the exponent $\frac{1}{2}$ appears as a technical limit in our proof, we provide a heuristic argument that let us think this exponent is optimal, in the following sense.

Conjecture 3. *There exists no deterministic function h and exponent $\varepsilon > 0$ such that almost surely, there exists C such that for all N ,*

$$|ND_N - h(N)| \leq CN^{-\frac{1}{2}-\varepsilon}.$$

Let us remark that if this conjecture were to be true it would not prevent $N(D_N - D_{-N})$ to have a smaller asymptotic order.

This theorem is complemented with a study of the area of the set of points around which two Brownian motion both winds a lot of time. This study is quite technical, but the proposition 2.2.10 is written in such a way that it can be read directly.

E3.3 Chapter 3: asymptotic study of the sets of large windings

In Chapter 3, we prove that the random measure $N\mathbb{1}_{\mathcal{D}_N} dz$ converges almost surely, weakly, toward the occupation measure of the planar Brownian motion. This result is somehow the crystallisation of the idea underlying the bootstrap, and according to which the set \mathcal{D}_N , for N large, is not only located near the trajectory, but also in a very balanced way along this trajectory.

Theorem 4. *The measure $N\mathbb{1}_{\mathcal{D}_N} dz$ converges almost surely, weakly, toward the occupation measure of the Brownian motion.*

We will have a minor use of this result, in Section 4.6 only.

E3.4 Chapter 4: Green formula

In the fourth chapter, we finally establish a Green's formula for the Brownian motion, with an almost sure convergence. As we already explained, our regularity scheme is not the one used by W. Werner: we only truncate the winding function θ when it takes too large values (in absolute values).

Theorem 5. *The sum*

$$\sum_{N=1}^{N_0} (D_N - D_{-N}) = \int_{\mathbb{R}^2} \max(-N_0, \min(\theta(z), N_0)) dz$$

converges, almost surely and in L^p for all $p \in [1, +\infty)$, as $N_0 \rightarrow +\infty$, toward the Lévy area (3)

We also prove the following result, in which the Cauchy behaviour of the Spitzer's theorem comes up again. Heuristically, this result indicates that the winding of the Brownian motion around a point chosen at random behaves a Cauchy law. The major difference with the Spitzer's theorem is that the Brownian motion is drawn once and kept fixed here. In particular, the law of the winding θ is not 'centered' around 0 anymore, but around the Lévy area of the Brownian motion

Theorem 6. *Let $X : [0, 1] \rightarrow \mathbb{R}^2$ be a Brownian motion, defined on a probability space $(\Omega^X, \mathcal{F}^X, \mathbb{P}^X)$. For all positive real K , let also \mathcal{P}_K be a Poisson process on \mathbb{R}^2 with intensity $K dz$, defined on another probability space. Then, \mathbb{P}^X -almost surely, the sum*

$$\frac{1}{K} \sum_{z \in \mathcal{P}_K} \theta(z)$$

converges in distribution, as $K \rightarrow +\infty$, toward a Cauchy random variable with position parameter the Lévy area (3).

It seems to us that this Cauchy distribution is a better description of some physics situations than the sole Lévy area, as for example when we consider the magnetic field generated by randomly located dipoles. This result then predicts a phenomenon of non-convergence toward the ‘average’ value, and appears to us as the most important result of the thesis from an applied point of view.

E3.5 Chapter 5: Liouville area enclosed by a Brownian motion

In the chapter 5, we look at the area enclosed by the Brownian motion, as in the previous chapters, but now with a Gaussian multiplicative chaos as the area measure replacing the Lebesgue one.

A Gaussian multiplicative chaos M is a random Borel measure which can be described informally by the formula

$$M(dz) = e^{\gamma\Phi_z - \frac{\gamma^2}{2}\mathbb{E}[\Phi_z^2]} dz$$

where Φ is a centered Gaussian field, whose covariance kernel K admits a logarithmic divergence near the diagonal, in the sense that $K(z, w) = \log_+(|z - w|^{-1}) + g(z, w)$, for some continuous function g defined on $\mathbb{R}^2 \times \mathbb{R}^2$. Typically, Φ is a Gaussian free field.

For such a kernel, Φ is only defined as a random distribution, and the previous formula for M does not have an immediate meaning. Actually, the works of J.-P. Kahane [29] allowed to define such a measure in a perfectly rigorous way, provided that the *intermittency parameter* γ lies in $[0, 2)$.⁹

The measure M is known to be much easier to define and study when $\gamma < \sqrt{2}$. The reason is that for all Borel set A with finite Lebesgue measure, the quantity $M(A)$ then have a finite moment of order 2, which allows to use Hilbertian technics. The main result of this chapter shows that it is possible to define the M -area enclosed by the Brownian motion, provided that $\gamma < \sqrt{4/3}$.

We will assume that the measure M is define on a probability space $(\Omega^M, \mathcal{F}^M, \mathbb{P}^M)$, whilst the Brownian motion X is defined on a second probability space $(\Omega^X, \mathcal{F}^X, \mathbb{P}^X)$.

Theorem 7. *Let $\gamma < \sqrt{4/3}$ and $p \in [1, \frac{4}{\gamma^2})$. For all $s < t \in [0, 1]$, the quantity*

$$\int_{\mathbb{R}^2} \max(-N_0, \min(\theta_{X_{|[s,t]}}(z), N_0)) dM(z)$$

converges in $L^p(\Omega^X, L^2(\Omega^M))$ as $N_0 \rightarrow +\infty$, toward a limit $\mathbb{A}_{s,t}$. In particular, the convergence holds in $L^2(\Omega^X \times \Omega^M)$.

E3.6 Chapter 6: trajectorial properties of the Liouville area enclosed by a curve

The Chapter 6 starts with a definition of the M -area enclosed by a curve smoother than a Brownian motion, with M which continues to be a Gaussian mutliplicative chaos. We then look at some

⁹We actually know how to define such a measure as well for $\gamma = 2$, with an additional normalization, and as well for $\gamma > 2$. Yet, the construction and the behaviour in these cases are quite different than in the case $\gamma \in [0, 2)$.

properties of the function which to s and t associates the M -area enclosed by the curve restricted to the interval $[s, t]$ —the curve being either a Brownian one or a smoother one. As usual, this restricted curve is closed with a straight line segment when its endpoints do not agree.

We prove that a Chen's relation (or, say, Chasles relation) holds in both cases. Using the notation $\mathbb{A}_{s,t}$ for the M -area enclosed by the part of the curve between s and t , such a relation can be written

$$\mathbb{A}_{s,t} = \mathbb{A}_{s,u} + \mathbb{A}_{u,t} + \varepsilon_{s,u,t} M(T_{s,u,t}), \quad (7)$$

with $\varepsilon_{s,u,t} \in \{-1, 1\}$. Such a property is, in some sense, the single one that a family $(\mathbb{A}_{s,t})_{s < t \in [0,1]}$ should satisfy in order that it deserves to be called *area enclosed by the curve* $X_{|[s,t]}$ (under the area measure M).

We also prove some regularity results (namely, continuity and Hölder continuity) of the function $(s, t) \mapsto \mathbb{A}_{s,t}$.

In the Euclidean case, that is when the area measure is the Lebesgue one, these two properties—Chen relation and regularity—followed directly from the Green's formula and the classical results concerning the Young and stochastic integrals.

Theorem 8 (Brownian case). *Let $\gamma < \sqrt{4/3} \simeq 1.15\dots$ and $p \in [1, \frac{4}{\gamma^2})$.*

- ◊ *For all reals $s < u < t$, $\mathbb{P}^X \otimes \mathbb{P}^M$ almost surely, the relation (7) is satisfied. The collection of random variables $\mathbb{A} = (\mathbb{A}_{s,t})_{s < t}$ admits a version which satisfies (7) for all s , u , and t .*
- ◊ *If moreover $\gamma < 2(\sqrt{2} - 1) \simeq 0.82\dots$, the collection of random variables $\mathbb{A} = (\mathbb{A}_{s,t})_{s < t}$ admits a continuous version, which still satisfies (7) for all s , u , and t . This version is then β -Hölder continuous, as a function of two variables, for β sufficiently small.*

In [22], and simultaneously in [4], the authors succeed to define a Liouville Brownian motion \mathcal{X} , associated with the measure M , whose trajectory is the one of a usual Brownian motion runned up to a random time. When $\gamma < 2(\sqrt{2} - 1)$, the continuous modification of \mathbb{A} is defined for all t , which allows also to define the area enclosed by the curve \mathcal{X} .

Théorème 10 (Smoother curves). *Let $\alpha > \frac{1}{2}$, $\gamma < 2$, and $Y = (Y^1, Y^2)$ an α -Hölder continuous function. Let $\theta_{s,t}^Y$ be the winding function of $Y_{|[s,t]}$.*

- ◊ *For all $s < t \in [0, 1]$, \mathbb{P}^M -almost surely, $\theta_{s,t}^Y \in L^1(\mathbb{R}^2, M)$, et*

$$\mathbb{A}_{s,t}^Y := \int_{\mathbb{R}^2} \theta_{s,t}^Y dM \text{ lies in } L^1(\Omega^M).$$

- ◊ *For all $s < u < t$, \mathbb{P}^M -almost surely, the relation (7) is satisfied. The collection of random variables $\mathbb{A}^Y = (\mathbb{A}_{s,t}^Y)_{s < t}$ admits a version which satisfies (7) for all s , u , and t .*
- ◊ *If moreover $\gamma < \sqrt{2}$ and $\alpha > \frac{1}{2}(1 - \frac{\gamma^2}{4})^{-1}$, the collection of random variables $\mathbb{A} = (\mathbb{A}_{s,t})_{s < t}$ admits a continuous version, which still satisfies (7) for all s , u , and t . This version is then β -Hölder continuous, as a function of two variables, for β sufficiently small.*

For both these theorems, we also give explicit possible values for β , as a function of γ and α . Nonetheless, we do not expect these explicit values to be optimal. In particular, we rely on a variation of the Kolmogorov theorem, which seems to us to be better suited to a monofractal framework than to the multifractal framework of the Gaussian multiplicative chaos.

The chapters 1, 2, and 4, in which we prove the theorems 1, 2, 5 and 6, are mainly coming from the prepublication [43]. We have decided to insert in the middle the chapter 3, which comes from the prepublication [44], and in which we prove the theorem 4. Indeed, it seemed to us that it was important to obtain this result as soon as possible, since it largely explains our understanding of the set \mathcal{D}_N , and also because it allows us to show the results of the section 4.6 (which we omitted in [43]). The theorems 7, 8 and 10 comes from the prepublication [42].

E3.7 The key idea in our study of the Brownian windings

A large part of the thesis rely on a simple idea that we now illustrate, in the framework of theorem 2. As N is large, the set \mathcal{D}_N is located near the trajectory, and in an extremely balanced way along this trajectory.¹⁰ Besides, for almost all the points in this set, the large part of the winding is only due to a small part of the trajectory.

Concretely, it means it should be possible to cut the trajectory into T small pieces, and study the large winding sets of each of these small pieces, instead of studying directly the large winding set of the whole curve. Writing \mathcal{D}_N^i for the large winding set of the i^{th} piece of the Brownian motion, and D_N^i for its Lebesgue measure, we have approximately

$$\mathcal{D}_N \simeq \bigsqcup_{i=1}^T \mathcal{D}_N^i \quad \text{and} \quad D_N \simeq \sum_{i=1}^T D_N^i, \quad (8)$$

where D_N^i is the Lebesgue measure of the set \mathcal{D}_N^i .

The self-similarity and Markov property of the Brownian motion give us the information that the random variables \mathcal{D}_N^i are independent, and have the same law as the one of \mathcal{D}_N , up to a scaling factor.

We then have a kind of concentration: as the fluctuations of each of the D_N^i must compensate each other stochastically, the fluctuation of D_N itself cannot be too large. We are actually comparing the fluctuation of D_N to itself, with an additional error term coming from the fact that the approximation (8) is not exact.

On the technical aspect, one can roughly distinguish two steps.

- ◊ On the one hand, we have to give a meaning to the informal relation (8): one has actually an upper and lower bound for \mathcal{D}_N , between two sets which both look like the right-hand side of (8). When we take the Lebesgue measure, it leads to some error terms that need to be controlled.
- ◊ On the other hand, we have to understand how this self-similarity relation allows indeed to control the fluctuations of \mathcal{D}_N : *a posteriori*, it is actually a simple recursion.

¹⁰This first part of the idea is formally materialised in Theorem 4.

This idea is based on the fractal behaviour of the Brownian motion, and it is possible that it also allows to study the windings of some other kind of fractal curves – fractional Brownian motion in particular. In practice, we still need to know a first order asymptotic on the values \mathcal{D}_N associated with the curve if we want to apply this idea.

Notation

1 Curves and windings

We will use the notation X exclusively for a standard Brownian motion from $[0, 1]$ to \mathbb{R}^2 , and the notation Y exclusively for a deterministic continuous function from $[0, 1]$ to \mathbb{R}^2 . The notation Z is used to designate a possibly random continuous function from $[0, 1]$ to \mathbb{R}^2 (in practice, either X or Y). We will sometimes call such functions *curves*, to emphasize a geometric aspect.

In order to define a winding function, we need to have a curve whose endpoints are equal. Hence, we write \bar{Z} the concatenation of a curve Z with the line segment from Z_1 to Z_0 . A precise parametrization of \bar{Z} is not necessary to define the associated winding function, which is written θ^Z . This function is defined from $\mathbb{R}^2 \setminus \text{Range}(\bar{Z})$ to \mathbb{Z} . We also write $\theta = \theta^X$ for the winding function of the planar Brownian motion X .

For a relative integer N , we define the set

$$\mathcal{A}_N^Z = \{z \in \mathbb{R}^2 \setminus \text{Range}(\bar{Z}) : \theta^Z(z) = N\}.$$

For a *positive* integer N , we define the sets

$$\mathcal{D}_N^Z = \{z \in \mathbb{R}^2 \setminus \text{Range}(\bar{Z}) : \theta^Z(z) \geq N\}, \quad \mathcal{D}_{-N}^Z = \{z \in \mathbb{R}^2 \setminus \text{Range}(\bar{Z}) : \theta^Z(z) \leq -N\}.$$

Since we are mostly interested in the Lebesgue measure of such sets, for curves Z whose range has a vanishing Lebesgue measure, we sometimes omit to mention that z must not lie on $\text{Range}(\bar{Z})$.

Very often, we only look at a part of a given curve Z . We write Δ the set $\{(s, t) \in [0, 1] : s \leq t\}$. For $(s, t) \in \Delta$, we write $Z_{s,t}$ the restriction of Z to the interval $[s, t]$, concatenated with the segment between Z_t and Z_s . We then write $\theta_{s,t}^Z = \theta^{Z_{s,t}}$, and $\theta_{s,t} = \theta_{s,t}^X$. More generally, in all the notations, a subscript s, t means that we replace the curve \bar{Z} with $Z_{s,t}$, and an absence of the superscript Z means that $Z = X$.

Very often, we will consider the case $s = \frac{i-1}{T}$, $t = \frac{i}{T}$, for some large integer T which is given as a function of N , and with $i \in \{1, \dots, T\}$. In this case, the subscripts s, t are replaced by a superscript i . For example, \mathcal{D}_N^i stands for $\mathcal{D}_{N, \frac{i-1}{T}, \frac{i}{T}}^X$.

We will also need to consider the sets of points around which different parts of the same Brownian motion wind a large number of times. For two positive integers N and M , for $i, j \in \{1, \dots, T\}$ with $i \neq j$, we denote by $\mathcal{D}_{N,M}^{i,j}$ the set

$$\mathcal{D}_{N,M}^{i,j} = \{z \in \mathbb{R}^2 \setminus (\text{Range}(Z^i) \cup \text{Range}(Z^j)) : |\theta^i(z)| \geq N, |\theta^j(z)| \geq M\}.$$

Remark the absolute values. In particular, the relation between \mathcal{D}_N^i , \mathcal{D}_M^j and $\mathcal{D}_{N,M}^{i,j}$ is

$$\mathcal{D}_{N,M}^{i,j} = (\mathcal{D}_N^i \cap \mathcal{D}_M^j) \cup (\mathcal{D}_N^i \cap \mathcal{D}_{-M}^j) \cup (\mathcal{D}_{-N}^i \cap \mathcal{D}_M^j) \cup (\mathcal{D}_{-N}^i \cap \mathcal{D}_{-M}^j).$$

For any set written with a curly letter, the same notation but with a straight letter is used to designate the Lebesgue measure of the set: for example, D_N^i is the Lebesgue measure of \mathcal{D}_N^i . Otherwise, the Lebesgue measure of a set $E \subset \mathbb{R}^2$ is also written $|E|$.

2 Measures and probability laws

There are mostly three kinds of random objects that appear in the different chapters: the Brownian motion X , Poisson point processes \mathcal{P} on the plane, and random measures \mathbf{M} on the plane. These different objects are always assumed to be independent, but there is actually no reason why they should even be defined on the same probability spaces. We thus denote respectively by $(\Omega^X, \mathcal{F}^X, \mathbb{P}^X)$, $(\Omega^{\mathcal{P}}, \mathcal{F}^{\mathcal{P}}, \mathbb{P}^{\mathcal{P}})$, and $(\Omega^{\mathbf{M}}, \mathcal{F}^{\mathbf{M}}, \mathbb{P}^{\mathbf{M}})$ the spaces carrying X , \mathcal{P} , and \mathbf{M} .

Finally, we will denote by $(\Omega, \mathcal{F}, \mathbb{P})$ the product probability space. There is in fact no statement involving both \mathcal{P} and \mathbf{M} , so that either $\Omega = \Omega^X \otimes \Omega^{\mathcal{P}}$ or $\Omega = \Omega^X \otimes \Omega^{\mathbf{M}}$, depending on the framework. When neither \mathcal{P} nor \mathbf{M} is involved, we freely use Ω or Ω^X , depending on what we want to emphasize.

Sometimes, Ω^X is also assumed to be large enough to support other random variables, and in particular a second Brownian motion X' independent from X .

In a few cases, we need to specify that X starts from a given point z in the plane, and we then denote by \mathbb{P}_z (or by \mathbb{P}_z^X) a probability law under which $X : [0, 1] \rightarrow \mathbb{R}^2$ is a planar Brownian motion started from z . Also, for $z, z' \in \mathbb{R}^2$, $\mathbb{P}_{z,z'}$ is a probability law under which $X : [0, 1] \rightarrow \mathbb{R}^2$ and $X' : [0, 1] \rightarrow \mathbb{R}^2$ are independent Brownian motions started respectively from z and z' .

The \mathbb{R}^2 -valued Gaussian distribution with mean z and variance σ^2 is denoted $\mathcal{N}(z, \sigma^2)$. Its density at w with respect to the Lebesgue measure is given by $p_{\sigma^2}(z, w)$, where $p_t(z, w)$ denotes the heat kernel on \mathbb{R}^2 ,

$$p_t(z, w) = \frac{1}{2\pi t} e^{-\frac{|z-w|^2}{2t}}.$$

The \mathbb{R} -valued Cauchy distribution with *position parameter* x and *scale parameter* $\sigma > 0$ is denoted by $C(x, \sigma)$. Its density at y with respect to the Lebesgue measure (on \mathbb{R}) is

$$\frac{\sigma}{\pi(\sigma^2 + (x - y)^2)}.$$

In particular, a random variable C with law $C(x, \sigma)$ is not integrable, but the limit

$$\lim_{N \rightarrow \infty} \mathbb{E}[C \mathbb{1}_{|C| \leq N}]$$

exists and is equal to the position parameter x .

3 Exponents and asymptotic notations

In many proofs, the integer T that we mentioned earlier is a function of N given by $T = \lfloor N^t \rfloor$, for a real number t which is always assumed to lie in $(0, 1)$. This specific choice of T can be replaced with any integer-valued function equivalent to N^t . Besides, one can think of t as being very small. Actually, most of the proofs contain two parts: in the first part, the parameter t is arbitrary in some range near zero, but fixed, and we prove some recursive bound by cutting the curve into small pieces. In the second part, we complete the recursion using the *bootstrap* method. The value of t decreases between each step of recursion, and goes to 0 if the bootstrap is ‘successful’. Otherwise, it basically means that there is a spoiling error term which prevents us from obtaining an optimal bound.

Similarly, many proofs contain a second integer M given as a function of N by $M = \lfloor N^m \rfloor$, for a real number m which is always assumed to lie in $(0, 1)$ as well. However, in most proofs, and in contrast with t , one should think of m as being very close to $\frac{1}{2}$. The purpose of this value is to keep a balance between some error terms proportional to a positive power of M , and some error terms proportional to a negative power of M .

For two functions f and g on \mathbb{N} that do not vanish, we write $f \sim g$ when $\lim \frac{f}{g} = 1$, $f = o(g)$ when $\lim \frac{f}{g} = 0$, and $f = O(g)$ when $\limsup \left| \frac{f}{g} \right| < +\infty$.

Less conventionally, for a non-negative function f defined on \mathbb{N}^* and a real number c , we write $f(N) \leq N^{c+o(1)}$ as a shortcut for the sentence *for all $c' > c$, there exists a constant C such that for all $N \in \mathbb{N}^*$, $|f(N)| \leq CN^{c'}$.*

Finally, for a real number x and a positive integer N , we write $[x]_N = \max(-N, \min(x, N))$.

Part I

Large winding sets of the Brownian motion

Chapter 1

Prelude: Green's formula in Young integration theory

We prove a Green's formula in the framework of Young integration, and look at a first implication.

1.1 Introduction

In this chapter, we do not yet look at the Brownian motion. Though we do provide some results, this chapter is mostly motivational. We advise a reader that would be interested only in the situation of the Brownian motion to read this section and to skip the next one.

We write $Y = (Y^1, Y^2)$ a continuous function from $[0, 1]$ to \mathbb{R}^2 . For $\alpha \in [0, 1]$, the function Y (resp. Y^1) is said to be α -Hölder continuous, which is written $Y \in \mathcal{C}^\alpha$, if the quantity

$$\|Y\|_{\mathcal{C}^\alpha} = \sup_{t \neq s} \frac{|Y_t - Y_s|}{|t - s|^\alpha}$$

is finite.

A *dissection* $\mathbf{t} = (t_0, \dots, t_n)$ of $[0, 1]$ is a finite increasing sequence $0 = t_0 < \dots < t_n = 1$. Its *mesh* $|\mathbf{t}|$ is the positive real $\max\{t_i - t_{i-1} : i \in \{1, \dots, n\}\}$. The function Y (resp. Y^1) is said to have *finite p -variation* if the quantity

$$\|Y\|_p = \left(\sup_{\mathbf{t}} \sum_{i=1}^n |Y_{t_i} - Y_{t_{i-1}}|^p \right)^{\frac{1}{p}}$$

is finite (the supremum is taken over all dissections). We write by \mathcal{V}^p the set of continuous functions Y^1 from $[0, 1]$ to \mathbb{R} with finite p -variation, and $\mathcal{V}^{p,q} = \mathcal{V}^p \times \mathcal{V}^q$.

When $p = \alpha^{-1}$, $\|\cdot\|_{\mathcal{C}^\alpha}$ and $\|\cdot\|_p$ are related by the property that any α -Hölder continuous function has finite p -variation, and that any continuous function with finite p -variation admits a reparametrization which is α -Hölder continuous.

The theory of Young integration (as defined initially in [51]) allows to define the integral $\int_0^1 Y_s^2 dY_s^1$ for any $Y \in \mathcal{V}^{p,q}$, provided $p^{-1} + q^{-1} > 1$. This integral is usually presented as a limit

of Riemann sums corresponding to dissections with small mesh:

$$\int_0^1 Y_s^2 dY_s^1 := \lim_{|\mathbf{t}| \rightarrow 0} \sum_{i=1}^n Y_{\xi_i}^2 (Y_{t_i}^1 - Y_{t_{i-1}}^1),$$

where $\mathbf{t} = (t_1, \dots, t_n)$, and $\xi_i \in [t_{i-1}, t_i]$ is arbitrary.

One can take convex combination of different choices for ξ_i , and end up for example with

$$\int_0^1 Y_s^2 dY_s^1 := \lim_{|\mathbf{t}| \rightarrow 0} \sum_{i=1}^n \frac{Y_{t_i}^2 + Y_{t_{i-1}}^2}{2} (Y_{t_i}^1 - Y_{t_{i-1}}^1).$$

The right-hand side, for a given \mathbf{t} , can also be seen as the integrals of the differential 1-form $x dy$ along the piecewise-linear approximations of Y , with interpolation points the Y_{t_i} .

For a smooth differential 1-form $\eta = \eta^1 dx + \eta^2 dy$ and a continuous curve $Y = (Y^1, Y^2) : [0, 1] \rightarrow \mathbb{R}^2$, we will say that the integral of η along Y is well-defined in the sense of Young if there exists $p_1, p_2, q_1, q_2 \geq 1$ such that $p_1^{-1} + q_1^{-1} > 1$, $p_2^{-1} + q_2^{-1} > 1$, and

$$t \mapsto \eta^1(Y_t) \in \mathcal{V}^{p_1}, Y^1 \in \mathcal{V}^{q_1}, t \mapsto \eta^2(Y_t) \in \mathcal{V}^{p_2}, Y^2 \in \mathcal{V}^{q_2}.$$

In that case, the integral $\int_Y \eta$ is defined as

$$\int_Y \eta = \int_0^1 \eta^1(Y_t) dY_t^1 + \int_0^1 \eta^2(Y_t) dY_t^2.$$

Alternatively, when the integral of η along Y is well-defined, it is the limit of the integrals of η along piecewise-linear approximations of Y , when the mesh of the approximation goes to zero.

In particular, when p and q are both strictly smaller than 2 and $Y \in \mathcal{V}^{p,q}$, the integral of η along Y is well-defined for all smooth 1-form η .

When the integral of η along Y is well-defined, we will show that it is possible to define the $d\eta$ -area¹ enclosed by Y , and that the Green formula extends to this framework.

Theorem 1.1.1. *Let $p, q \geq 1$ be reals such that $\delta = \frac{1}{p} + \frac{1}{q} - 1 > 0$. Let $Y \in \mathcal{V}^{p,q}$, and \bar{Y} the concatenation of Y with the straight line segment from Y_1 to Y_0 .*

Then, the range of Y has zero Lebesgue measure and its winding function θ^Y lies in $L^r(\mathbb{R}^2, \mathbb{Z})$ for all $r \in [1, 1 + \delta)$. Besides, we have the Green formula

$$\int_{\mathbb{R}^2} \theta^Y(z) dz = \int_{\bar{Y}} x dy, \quad (1.1)$$

provided that the right-hand side is interpreted as a Young integral.

In particular, for all smooth 1-form η integrable along Y , we have the Green formula

$$\int_{\mathbb{R}^2} \theta^Y d\eta = \int_{\bar{Y}} \eta, \quad (1.2)$$

provided that the right-hand side is interpreted as a Young integral.

¹Here the 2-form $d\eta$ is the exterior derivative of η . It is in general not a volume form, so the expression *area* is a bit improper. Besides, area is counted algebraically and with multiplicity.

In [8, Theorem 3.2], a similar result is shown in the case where Y is further assumed to be simple (in which case the integrability of θ is not a question).

As an application, we have the following corollary, which to our knowledge was not known previously.

Corollary 1.1.2. *Let $Y = (Y_1, Y_2)$ be continuous. Let η be a smooth 1-form and ϕ be a diffeomorphism of \mathbb{R}^2 . Assume that η is integrable along Y , and that the push-forward $\phi_*(\alpha)$ is integrable along $\phi \circ Y$. Then, the Young integral of α along Y is equal to the Young integral of $\phi_*(\alpha)$ along $\phi \circ Y$.*

Proof. First assume that $Y_1 = Y_0$, so that $\bar{Y} = Y$. Then,

$$\int_Y \eta = \int_{\mathbb{R}^2} \theta^Y d\eta = \int_{\mathbb{R}^2} \theta^{\phi \circ Y} \phi_*(d\eta) = \int_{\mathbb{R}^2} \theta^{\phi \circ Y} d\phi_*(\eta) = \int_{\phi \circ Y} \phi_*(\eta).$$

To conclude for the general case, let $Y' : [0, 1] \rightarrow \mathbb{R}^2$ be the linear parametrization of $[Y_1, Y_0]$. It suffices to remark that both Y' (parameterized linearly) and $\phi \circ Y'$ are smooth, so that

$$\int_{Y'} \eta = \int_{\phi \circ Y'} \phi_*(\eta)$$

from the usual rules of calculus. □

This seems to say that the Young integral has some diffeomorphism invariance, but this is actually false. Indeed, the condition that η is integrable along Y is *not* equivalent to the condition that $\phi_*(\eta)$ is integrable along $\phi \circ Y$ (unless $p = q < 2$). Nonetheless, we can push a step further and make the following definition.

Definition 1.1.3. *Let $Y : [0, 1] \rightarrow \mathbb{R}^2$ be a continuous function and η a smooth 1-form. Assume that there exists a diffeomorphism ϕ such that the integral of $\phi_*(\eta)$ along $\phi \circ Y$ is well-defined. Then, we define*

$$\int_Y \eta := \int_{\phi \circ Y} \phi_*(\eta).$$

The advantage of this definition, which does not depend on the choice of ϕ , is that it frees the definition of $\int_Y \alpha$ from the choice of a specific coordinate system on the plane.

Corollary 1.1.2 can be interpreted as the fact that a Young integral is well-approximated not only by integrals along piecewise-linear approximations of the curve, but also by integrals along piecewise-geodesic approximations of the curve, for an arbitrary Riemannian metric. This can be proved directly, without a Green formula, in the case both p and q are smaller than 3. For the general case however, it seems to be more difficult. The reason is that, with a naive approach, there is a remainder of order $|\mathbf{t}|^{3p-1-1}$, and one of order $|\mathbf{t}|^{3q-1-1}$, which does not go to zero as the dissection becomes thinner.

Remark 1.1.4. *The value of δ in Theorem 1.1.1 is optimal. For $p = q$, this is seen by considering the curve Y which goes once along each of the circles with center $(0, n^{-\alpha})$ and radius $n^{-\alpha}$ (see Figure 1.1 below). This curve has finite p -variation for all $p > \frac{1}{\alpha}$. Nonetheless, there exists C such that for all $N > 0$, $|\{z : \theta^Y(z) = N\}| = CN^{-2\alpha-1}$. It follows that the winding function θ^Y does not belong to $L^{2\alpha}(\mathbb{R}^2)$. For $p \neq q$, we replace the n -th circle with an ellipse with width $2n^{-\alpha}$ and height $2n^{-\beta}$, with $p > \frac{1}{\alpha}$ and $q > \frac{1}{\beta}$.*

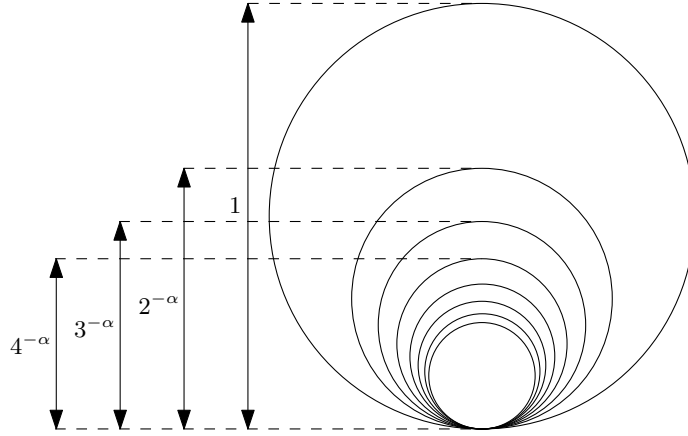

Figure 1.1: The function Y , here for $\alpha = 2/3$. Inspired from Figure 5, p.11 in [35].

1.2 Proof of Theorem 1.1.1

To prove Theorem 1.1.1 (and a few lemmas that we will use in Chapter 6), we will partly follow a path which is parallel to the one used to build the Young integral. We used the treatment given in [20], but we also refer the reader to [19] and [36] as general references.² As a preliminary material, we state four previously known results. The first one is *not* part of the previously cited textbook, and our principal contribution is to incorporate this lemma in the middle of the construction of the Young integral.

We will call *control* a function $\omega : \Delta = \{(s, t) : 0 \leq s \leq t \leq 1\} \rightarrow \mathbb{R}$ which is continuous, vanishes on the diagonal, and satisfies $\omega_{s,u} + \omega_{u,t} \leq \omega_{s,t}$ for $s < u < t$.

Theorem 1.2.1 (Banchoff-Pohl inequality, [3]). *Let $Y : [0, 1] \rightarrow \mathbb{R}^2$ be a continuous function with finite 1-variation. Then, $\theta^Y \in L^2(\mathbb{R}^2)$ and*

$$\|\theta^Y\|_{L^2}^2 \leq \frac{\|Y\|_1^2}{4\pi}.$$

Theorem 1.2.2 ([20, lemma 6.2]). *Let $\Gamma : \Delta = \{0 \leq s < t \leq 1\} \rightarrow \mathbb{R}$ and assume that*

◊ *there exists a control $\hat{\omega}$ such that*

$$\lim_{r \rightarrow 0} \sup_{(s,t) \in \Delta: \hat{\omega}(s,t) \leq r} \frac{\Gamma_{s,t}}{r} = 0,$$

◊ *there exist a control ω and $\gamma > 1, \xi > 0$ such that*

$$|\Gamma_{s,t}| \leq |\Gamma_{s,u}| + |\Gamma_{u,t}| + \xi \omega(s, t)^\gamma$$

holds for $0 \leq s \leq u \leq t \leq 1$.

²The webpage of Fabrice Baudoin was also of great help to the author, and we strongly recommend it to anyone that would like to follow a quick introduction to the Young integral.

Then, for all $0 \leq s < t \leq 1$,

$$|\Gamma_{s,t}| \leq \frac{\xi}{1 - 2^{1-\theta}} \omega(s,t)^\gamma.$$

For a function $x : [0, 1] \rightarrow \mathbb{R}$ and a dissection $\mathbf{t} = (t_0, \dots, t_n)$ of $[0, 1]$, let $x^{\mathbf{t}}$ be the piecewise linear function defined by $x_t^{\mathbf{t}} = \frac{t-t_{i-1}}{t_i-t_{i-1}}x_{t_i} + \frac{t_i-t}{t_i-t_{i-1}}x_{t_{i-1}}$, where $i \in \{1, \dots, n\}$ is such that $t_{i-1} \leq t < t_i$.

Theorem 1.2.3 ([20, theorem 5.25]). *Let $x \in \mathcal{V}^p$. Let (\mathbf{t}_n) be a sequence of dissections of $[0, 1]$ with mesh converging to 0. Then, $x^{\mathbf{t}_n}$ converges to x in uniform norm and for all n ,*

$$\|x^{\mathbf{t}_n}\|_p \leq 3^{1-1/p} \|x\|_p.$$

Theorem 1.2.4 ([20, theorem 5.33] (Wiener's characterization)). *Let $x \in \mathcal{V}^p$. The following statements are equivalent:*

1. *x belongs to the p -variation closure of \mathcal{V}^1 .*

$$2. \lim_{\varepsilon \rightarrow 0} \sup_{\mathbf{t}: |\mathbf{t}| < \varepsilon} \sum_{i=1}^n d(x_{t_{i-1}}, x_{t_i})^p = 0.$$

To be clear, in the second statement, the supremum is taken over all dissections of $[0, 1]$ with mesh less than ε .

The proof of Theorem 1.1.1 is organized as follows. First, we show an inequality similar to the Young–Loève estimate: for smooth enough curves, the L^r norm of θ^Y can be controlled by the p (resp. q)-variation of its coordinates. This is Lemma 1.2.5. The usual Young–Loève estimate, for comparison, states that $\int_0^1 y \, dx - y(0)(x(1) - x(0))$ can be controlled by the same quantity.

We then show that θ^Y is defined almost everywhere (Lemma 1.2.6), that it lies in L^r for r small enough (Lemma 1.2.7), and finally that the equality (1.1) holds.

We fix once and for all p, q and δ as in Theorem 1.1.1.

Lemma 1.2.5. *Let $Y = (Y^1, Y^2) : [0, 1] \rightarrow \mathbb{R}^2$ be a continuous curve with finite 1-variation. Then, for every $r \in [1, 2]$, $\theta^Y \in L^r$. Moreover, for all $\delta \leq 1$ and all $r \in [1, 1 + \delta)$, one has*

$$\|\theta^Y\|_{L^r}^r \leq \frac{\|Y^1\|_p \|Y^2\|_q}{1 - 2^{1-\frac{1+\delta}{r}}}. \quad (1.3)$$

Proof. For $0 \leq s < t \leq 1$, set $\theta_{s,t} = \theta^{Y_{[s,t]}}$ and $\Gamma_{s,t} = \|\theta_{s,t}\|_{L^r}$. For $0 \leq s < u < t \leq 1$, let $T_{s,u,t}$ be the convex hull of $\{Y_s, Y_u, Y_t\}$.

For $f \in \mathcal{V}^p$, let $\|f\|_{p,[s,t]}$ be the p -variation norm of the restriction of f to $[s, t]$ (linearly reparametrized by $[0, 1]$). We will apply Theorem 1.2.2 with $\xi = 1$, with the controls $\omega_{s,t} = \|Y^1\|_{p,[s,t]}^{1/(1+\delta)} \|Y^2\|_{q,[s,t]}^{1/(1+\delta)}$ and $\tilde{\omega}_{s,t} = \|Y^1\|_{1,[s,t]} + \|Y^2\|_{1,[s,t]}$. These are the exact same controls that one uses to prove the Young–Loève estimate, and we refer to [20] again for the proof that these are indeed controls (see Proposition 1.15, Exercise 1.10, Proposition 5.8 and page 120).

Since θ takes its values in \mathbb{Z} , one has

$$\Gamma_{s,t} = \left(\int_{\mathbb{R}^2} |\theta_{s,t}(z)|^r dz \right)^{\frac{1}{r}} \leq \left(\int_{\mathbb{R}^2} \theta_{s,t}^2(z) dz \right)^{\frac{1}{r}} \leq \frac{\|Y\|_{1,[s,t]}^{\frac{2}{r}}}{4\pi} \leq \frac{\tilde{\omega}_{s,t}^{\frac{2}{r}}}{4\pi}.$$

This allows us to obtain the first assumption of 1.2.2.

Then, for $s < u < t$, set $\xi_{s,u,t} = \theta_{s,t} - \theta_{s,u} - \theta_{u,t}$, so that

$$|\xi_{s,u,t}| = \mathbb{1}_{T_{s,u,t}}.$$

Thus, $\|\theta_{s,t}\|_{L^r} \leq \|\theta_{s,u}\|_{L^r} + \|\theta_{u,t}\|_{L^r} + \|\mathbb{1}_{T_{s,u,t}}\|_{L^r}$, that is,

$$|\Gamma_{s,t}| \leq |\Gamma_{s,u}| + |\Gamma_{u,t}| + |T_{s,u,t}|^{\frac{1}{r}} \leq |\Gamma_{s,u}| + |\Gamma_{u,t}| + \omega(s,t)^{\frac{1+\delta}{r}}.$$

This is the second assumption of 1.2.2, with $\xi = 1$ and $\gamma = \frac{1+\delta}{r}$.

We now apply 1.2.2 to obtain the announced result. \square

Lemma 1.2.6. *For any $Y \in \mathcal{V}^{p,q}$, the range of Y has vanishing Lebesgue measure.*

Proof. Let $Y \in \mathcal{V}^{p,q}$. The range of $Y_{[\frac{k}{\varepsilon}, \frac{k+1}{\varepsilon}]}$ is included in a box of length $C\varepsilon^{1/p}$ and width $C\varepsilon^{1/q}$, for some constant C that depends only on Y, p, q . Such a box can be covered by $C'\varepsilon^{1/p+1/q-2}$ balls of diameter ε . Thus, it is possible to cover the whole range of Y with no more than $\varepsilon^{-1}C'\varepsilon^{1/p+1/q-2} = C'\varepsilon^{-(2-\delta)}$ balls of diameter ε . Thus, the range of Y has Hausdorff dimension at most $2 - \delta$, and thus has vanishing Lebesgue measure. \square

Lemma 1.2.7. *For any $Y \in \mathcal{V}^{p,q}$, the function θ^Y lies in $L^r(\mathbb{R}^2, \mathbb{Z})$ for any $r < 1 + \delta$. Besides,*

$$\|\theta^Y\|_{L^r}^r \leq \frac{3^{1-\delta}}{1 - 2^{1-\frac{1+\delta}{r}}} \|Y^1\|_p \|Y^2\|_q. \quad (1.4)$$

Proof. We set $Y^{(\varepsilon)}$ the ε -thickening of the range of Y , that is the set $\{z \in \mathbb{R}^2 : d(z, \text{Range}(Y)) < \varepsilon\}$. From the fact that the range of Y has vanishing measure, we deduce that the Lebesgue measure $|Y^{(\varepsilon)}|$ of $Y^{(\varepsilon)}$ goes to 0 with ε .

We now fix a sequence $(\delta_n)_{n \geq 0}$ decreasing to 0, and for all n , a dissection \mathbf{t}_n with mesh less than δ_n . We set $Y_n = (x^{\mathbf{t}_n}, y^{\mathbf{t}_n})$. We fix $\varepsilon > 0$, and n_0 such that for $n \geq n_0$, the range of Y_n is included in $Y^{(\varepsilon)}$. Then, for every $k > 0$ and $r < 1 + \delta$,

$$\begin{aligned} \int_{\mathbb{R}^2} \min(|\theta^Y(z)|^r, k) dz &\leq \int_{\mathbb{R}^2} |\theta^{Y_n}(z)|^r dz + k|Y^\varepsilon| \\ &\leq \left(\frac{\|x_n\|_p \|y_n\|_q}{1 - 2^{1-\frac{1+\delta}{r}}} \right)^r + k|Y^\varepsilon| \quad (\text{using Lemma 1.2.5}) \\ &\leq \left(\frac{3^{1-\delta} \|x\|_p \|y\|_q}{1 - 2^{1-\frac{1+\delta}{r}}} \right)^r + k|Y^\varepsilon| \quad (\text{using Lemma 1.2.3}). \end{aligned}$$

We let ε go to zero and then k go to infinity to conclude. \square

Finally we are ready to show the theorem.

Proof of Theorem 1.1.1. Let $Y = (Y^1, Y^2) \in \mathcal{V}^{p,q}$. From the previous lemma, we know that both sides of (1.1) are well defined.

In the case when Y is piecewise-linear, an easy recursion on the number of vertices shows the equality stated by Theorem 1.1.1.

According to [20, Corollary 5.35], since Y^1 has finite p -variation, it belongs to the closure of \mathcal{V}^1 in p' -variation norm for all $p' > p$. Together with the Wiener's characterization, this implies

$$\lim_{\varepsilon \rightarrow 0} \sup_{\mathbf{t}: |\mathbf{t}| < \varepsilon} \sum_{i=1}^n |Y_{t_i}^1 - Y_{t_{i-1}}^1|^{p'} = 0.$$

Let $\mathbf{t} = (t_0 < \dots < t_n)$ be a dissection of $[0, 1]$. A consequence of Wiener's characterization is that when the mesh of \mathbf{t} is small enough, the maximum over $i \in \{1, \dots, n\}$ of $\|Y^1\|_{p', t_{i-1}, t_i}$ (resp. $\|Y^2\|_{q', t_{i-1}, t_i}$) is less than 1. We assume this condition to be satisfied.

We have the equality almost everywhere:

$$\theta^Y = \theta^{Y^{\mathbf{t}}} + \sum_{i=1}^n \theta^{Y_{[t_{i-1}, t_i]}}.$$

With $\delta' = \frac{1}{p'} + \frac{1}{q'} - 1 > 0$, and $p'' > p' > p$, $q'' > q' > q$ such that $\frac{1}{p''} + \frac{1}{q''} = 1$, we have:

$$\begin{aligned} \int_{\mathbb{R}^2} |\theta^Y(z) - \theta^{Y^{\mathbf{t}}}(z)| \, dz &\leq \sum_{i=1}^n \int_{\mathbb{R}^2} |\theta^{Y_{[t_{i-1}, t_i]}}(z)| \, dz \\ &\leq \frac{3^{1-\delta'}}{1-2^{\delta'}} \sum_{i=1}^n \|x\|_{p', t_{i-1}, t_i} \|y\|_{q', t_{i-1}, t_i} \quad (\text{using (1.4) with } r=1) \\ &\leq \frac{3^{1-\delta'}}{1-2^{\delta'}} \left(\sum_{i=1}^n \|x\|_{p'', t_{i-1}, t_i}^{p''} \right)^{\frac{1}{p''}} \left(\sum_{i=1}^n \|y\|_{q'', t_{i-1}, t_i}^{q''} \right)^{\frac{1}{q''}} \\ &\leq \frac{3^{1-\delta'}}{1-2^{\delta'}} \left(\sum_{i=1}^n \|x\|_{p', t_{i-1}, t_i}^{p'} \right)^{\frac{1}{p''}} \left(\sum_{i=1}^n \|y\|_{q', t_{i-1}, t_i}^{q'} \right)^{\frac{1}{q''}} \\ &\xrightarrow{|\mathbf{t}| \rightarrow 0} 0. \end{aligned}$$

Thus, $\theta^{Y^{\mathbf{t}}}$ converges in L^1 to θ^Y . Since the Young integral is also continuous and since (1.1) holds for the piecewise linear curve $Y^{\mathbf{t}}$, the integral $\int_{\mathbb{R}^2} \theta^{Y^{\mathbf{t}}}(z) \, dz$ converges to both the left-hand side and the right-hand sides of (1.1). This concludes the proof. \square

Chapter 2

Estimation of the large winding area

We study the asymptotic behaviour as N tends to infinity of the area of the set of points with winding at least N . We extend the first order asymptotic of [47] from L^2 to L^p for all p , and to the almost sure sense. In all these spaces, we also complete the asymptotic expansion by providing a bound on its second term.

2.1 Introduction

Let $X : [0, 1] \rightarrow \mathbb{R}^2$ be a planar Brownian motion. For $z \in \mathbb{R}^2$, let $\theta(z) \in \mathbb{Z}$ be the integer winding of X around the point z .

In this chapter, we study the Lebesgue area D_N of the set

$$\mathcal{D}_N = \{z \in \mathbb{R}^2 : \theta(z) \geq N\}$$

of points around which X winds a large amount of time. As we already mentioned in the introduction, W. Werner proved in [47] that D_N is equivalent in L^2 to $\frac{1}{2\pi N}$, as N goes to infinity:

$$\mathbb{E}[(ND_N - \frac{1}{2\pi})^2]^{\frac{1}{2}} \xrightarrow{N \rightarrow +\infty} 0.$$

We will show that this convergence also holds in L^p for all p , and in the almost sure sense. We will also prove that the convergence rate is at least $N^{-\frac{1}{2}+o(1)}$.

Theorem 2.1.1. *Almost surely,*

$$|ND_N - \frac{1}{2\pi}| \leq N^{-\frac{1}{2}+o(1)}.$$

For all $p \in [1, +\infty)$,

$$\mathbb{E}[|ND_N - \frac{1}{2\pi}|^p]^{\frac{1}{p}} \leq N^{-\frac{1}{2}+o(1)}.$$

We should mention that the main asymptotic order of D_N places it on the edge of summability, which is important for the Green formula. If the Brownian motion is replaced with a wilder process (or the Lebesgue measure with another measure, such as in Chapters 5 and 6), such as a fractional Brownian motion with Hurst parameter smaller than $\frac{1}{2}$, it can be expected that the main order asymptotic will behave as N^{-a} , for an exponent a smaller than 1. In such a case, for $D_N - D_{-N}$ to be summable, the gap must be larger than $1 - a$. We hope that it is possible to extend the method we use for the Brownian motion to other processes.

2.2 Area of large winding for independent Brownian motions

The goal of this section is to obtain an upper bound on the moments of the set where some different pieces of the same Brownian motion each winds a large number of time. The relevance of this estimation for the study the fluctuations of D_N will be explained in the next section. For now on, we can simply consider this as a technical estimation.

Definition 2.2.1. For a positive integer T and $i \in \{1, \dots, T\}$ set θ^i the winding function of the curve X restricted to the interval $[\frac{i-1}{T}, \frac{i}{T}]$.

For three positive integers N, M , and T , and three integers $i, j, k \in \{1, \dots, T\}$ with $i \neq j$, we set

$$\begin{aligned} \mathcal{D}_N^i &= \{z \in \mathbb{R}^2 : \theta^i(z) \geq N\}, \\ \mathcal{D}_{-N}^i &= \{z \in \mathbb{R}^2 : \theta^i(z) \leq -N\}, \\ \mathcal{D}_{N,M}^{i,j} &= \{z \in \mathbb{R}^2 : |\theta^i(z)| \geq N \text{ and } |\theta^j(z)| \geq M\}, \\ \mathcal{D}_M^{i,j,k} &= \{z \in \mathbb{R}^2 : |\theta^i(z)| \geq M, |\theta^j(z)| \geq M, \text{ and } |\theta^k(z)| \geq M\}. \end{aligned}$$

This section contains two lemmas (Lemmas 2.2.6 and 2.2.7) which provide bounds on the moment of order p of the measure of these sets. To prove these lemmas, we introduce, for each positive integers p and N , the p -points function $f_N^{(p)} : (\mathbb{R}^2)^p \rightarrow \mathbb{R}$ defined by

$$f_N^{(p)}(z_1, \dots, z_p) = \mathbb{P}(\forall i \in \{1, \dots, p\}, \theta(z_i) \geq N).$$

In order to understand the role played by this function when we estimate the p -th moment of the area of a set, let us remark that, for a random set $\mathcal{D} \subset \mathbb{R}^2$ with area D , the Fubini's theorem gives the equality

$$\mathbb{E}[D^p] = \int_{(\mathbb{R}^2)^p} \mathbb{P}(\forall i \in \{1, \dots, p\}, z_i \in \mathcal{D}) \, dz_1 \dots dz_p.$$

For a given tuple $\mathbf{z} = (z_1, \dots, z_p)$ of 2 by 2 distinct points in \mathbb{R}^2 , we expect the function $f_N^{(p)}(\mathbf{z})$ to be of order N^{-p} . In the case $p = 1$, this follows from previously known estimation (and it is directly related to the Cauchy behaviour in the Spitzer's theorem). For general p , the idea is roughly the following. For the event defining $f_N^{(p)}$ to occur, the Brownian motion must wind at least N/p times over one of the points z_i , and then at least N/p times over some other point, and so one. These p events have almost no correlation, so that $f_N^{(p)}$ should be at the most of order $(\frac{f_N^{(1)}}{p})^p$.

Nonetheless, since we want a bound on the integral of $f_N^{(p)}$, we need a bound on $f_N^{(p)}(\mathbf{z})$ which would be uniform over the tuples \mathbf{z} . The probability $f_N^{(p)}(\mathbf{z})$ increases when two points z_i, z_j goes close to each other, with a divergence which is expected to be logarithmic in $|z_i - z_j|$ (though it is obviously bounded by 1). This is why we have to add an additional $N^{o(1)}$ in the control of the p -th moment.

To make rigorous this reasoning to bound $f_N^{(p)}$, we start by proving a deterministic result (Sublemma 2.2.2). Then, we prove pointwise estimates in Sublemma 2.2.3, depending on the relative positions of the points z_1, \dots, z_p , from which we derive several integral bounds in Corollary 2.2.5.

The first assertion of the following lemma explains the meaning of the property that we are proving. The second assertion is the precise form under which we are going to use it.

Sublemma 2.2.2. *Let $g_1, \dots, g_p : [0, 1] \rightarrow \mathbb{R}$ be continuous functions with $g_i(0) = 0$ and $g_i(1) \geq 1$ for all $i \in \{1, \dots, p\}$.*

1. *There exists a permutation π of $\{1, \dots, p\}$ and $p + 1$ times $0 = s_1 < s_2 < \dots < s_{p+1} \leq 1$ such that for all $i \in \{1, \dots, p\}$,*

$$g_{\pi(i)}(s_{i+1}) - g_{\pi(i)}(s_i) \geq \frac{1}{p}.$$

2. *There exists a permutation π of $\{1, \dots, p\}$ such that the times $s_1^\pi < \dots < s_{p+1}^\pi$ in $[0, 1] \cup \{+\infty\}$ defined inductively by setting $s_1^\pi = 0$ and*

$$s_{i+1}^\pi = \inf \left\{ t \geq s_i^\pi : g_{\pi(i)}(t) - g_{\pi(i)}(s_i^\pi) = \frac{1}{p} \right\} \quad (2.1)$$

all belong to $[0, 1]$.

Proof. 1. We define the times s_1, \dots, s_{p+1} and the permutation π inductively, with a greedy algorithm. We set

$$s_2 = \inf \{ t \in [0, 1] : \exists i \in \{1, \dots, p\} : g_i(t) = \frac{1}{p} \}$$

and

$$\pi(1) = \min \{ i \in \{1, \dots, p\} : g_i(s_2) = \frac{1}{p} \}.$$

Then, for $k \in \{2, \dots, p\}$, the times s_1, \dots, s_{p+1} and the integers $\pi(1), \dots, \pi(k-1)$ being defined, we set

$$s_{k+1} = \inf \{ t \in [s_k, 1] : \exists i \in \{1, \dots, p\} \setminus \{\pi(1), \dots, \pi(k-1)\} : g_i(t) - g_i(s_k) = \frac{1}{p} \}$$

and

$$\pi(k) = \min \{ i \in \{1, \dots, p\} \setminus \{\pi(1), \dots, \pi(k-1)\} : g_i(s_{k+1}) - g_i(s_k) = \frac{1}{p} \}.$$

The times and permutation thus constructed have the desired property.

2. The times s_1, \dots, s_{p+1} constructed in the proof of the first assertion are exactly the times $s_1^\pi, \dots, s_{p+1}^\pi$ for the permutation π constructed in this same proof. \square

We will apply this result to the winding functions of a Brownian curve around p points in the plane. In this case, the times s_i^π as defined above are random times, indeed stopping times.

We now state and prove the second lemma of this section. For all positive real number β and all positive integer M , we define

$$T_\beta = \{ (z_1, \dots, z_p) \in (\mathbb{R}^2)^p : \min(\|z_i\|, \|z_i - z_j\| : i, j \in \{1, \dots, p\}, i \neq j) \leq M^{-\beta} \}.$$

Of course, if $p = 1$, T_β is the ball of radius $M^{-\beta}$ around the origin in \mathbb{R}^2 .

Sublemma 2.2.3. *For all positive integer p and all positive real β , there exists a constant C such that for all positive integer M and all $\mathbf{z} \in (\mathbb{R}^2)^p$,*

$$f_M^{(p)}(\mathbf{z}) \leq \begin{cases} 1 & \text{if } \mathbf{z} \in T_\beta, \\ C \log(M+1)^p M^{-p} & \text{if } \mathbf{z} \in (\mathbb{R}^2)^p \setminus T_\beta. \end{cases}$$

Moreover, for all $\mathbf{z} = (z_1, \dots, z_p) \in (\mathbb{R}^2)^p$,

$$f_M^{(p)}(\mathbf{z}) \leq 4 \exp\left(-\frac{\max \|z_i\|^2}{4}\right).$$

Remark 2.2.4. *A similar, but slightly stronger, version of this result is given in [47] in the case $p = 1$ and $p = 2$. The method used can also be extended to general p , but is more technical than the one we use here.*

Proof. The first inequality follows from the fact that $f_M^{(p)}(\mathbf{z})$ is a probability.

For the last inequality, we remark that $f_M^{(p)}(z_1, \dots, z_p) \leq f_M^{(1)}(z_i)$ for all $i \in \{1, \dots, p\}$. It is thus sufficient to show that for all M and for all $z \in \mathbb{R}^2$, $f_M^{(1)}(z) \leq 4 \exp(-\frac{\|z\|^2}{4})$. Let $X^* = \sup_{t \in [0,1]} \|X_t\|$. Since θ is zero outside the ball of radius X^* and M is positive, and using the reflection principle, we find

$$f_M^{(1)}(z) \leq \mathbb{P}(X^* \geq \|z\|) \leq 2\mathbb{P}\left(\sup_{t \in [0,1]} |X_t^1| \geq \|z\|/\sqrt{2}\right) \leq 8\Phi(\|z\|/\sqrt{2})$$

where $\Phi(x) = \frac{1}{\sqrt{2\pi x}} \int_x^\infty e^{-\frac{t^2}{2}} dt$. Since $\Phi(x) \leq \frac{1}{\sqrt{2\pi x}} e^{-\frac{x^2}{2}}$ for $x > 0$, for all $z \in \mathbb{R}^2$ with $\|z\| \geq \sqrt{2}$,

$$f_M^{(1)}(z) \leq 4e^{-\frac{\|z\|^2}{4}}.$$

For $\|z\| \leq \sqrt{2}$, it suffices to use the fact that $f_M^{(1)}(z)$ is a probability:

$$f_M^{(1)}(z) \leq 1 < 4e^{-\frac{1}{2}} \leq 4e^{-\frac{\|z\|^2}{4}}.$$

Only the second case remains to be shown. For a given value of M , the existence of a C for which the inequality holds is immediate. Thus, replacing C if necessary by a larger constant, it suffices to show the inequality for $M \geq 3p$.

For each $i \in \{1, \dots, p\}$, let $\tilde{\theta}_i : [0, 1] \rightarrow \mathbb{R}$ be the continuous determination of the angle of X around z_i , initialized to be 0 at time 0. The quantities $\theta(z_i)$ and $\tilde{\theta}_i(1)$ are related by

$$|\theta(z_i) - \frac{1}{2\pi} \tilde{\theta}_i(1)| \leq \frac{1}{2}. \quad (2.2)$$

We now apply Sublemma 2.2.2 to the functions $g_i = \frac{1}{2\pi(M-1)} |\tilde{\theta}_i|$. For a permutation π of $\{1, \dots, p\}$, we define the times $0 = s_1^\pi \leq \dots \leq s_{p+1}^\pi \leq 1$ by (2.1). Then,

$$f_M^{(p)}(z_1, \dots, z_p) \leq \mathbb{P}(\forall i \in \{1, \dots, p\}, |\tilde{\theta}_i(1)| \geq 2\pi(M-1)) \leq \sum_{\pi \in \mathfrak{S}_p} \mathbb{P}(s_{p+1}^\pi < +\infty).$$

Since the times s_i^π are stopping times, it is tempting to write

$$\mathbb{P}(s_{p+1}^\pi < +\infty) = \sum_{\pi \in \mathfrak{S}_p} \prod_{i=1}^p \mathbb{P}(s_{i+1}^\pi < +\infty | s_i^\pi < +\infty),$$

to use the Markov property at time s_i^π and to use a known bound on the maximal winding of a Brownian motion around a given point (namely $z_{\pi(i+1)}$) during the interval of time $[0, 1]$. However, this bound becomes useless as the point around which the winding is measured gets close to the starting point of the Brownian motion, and we cannot exclude that our Brownian motion is close to $z_{\pi(i+1)}$ at the time s_i^π .

To circumvent the problem, we will sacrifice the last turn of X around $z_{\pi(i)}$, with the idea that during this turn, X must be far from $z_{\pi(i+1)}$ at some point. To formalize this idea, let us fix a permutation π and define the ray

$$d_i = \{z \in \mathbb{R}^2 : z = z_{\pi(i)} + \lambda(z_{\pi(i)} - z_{\pi(i+1)}), \lambda \in \mathbb{R}_+\},$$

as illustrated by Figure 2.1 below.

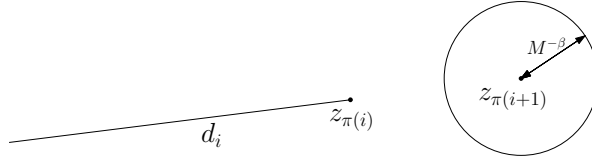

Figure 2.1: When the Brownian motion hits d_i , it cannot be too close to $z_{\pi(i+1)}$.

We would like to consider the last time before s_{i+1}^π where the Brownian motion is on the ray d_i , but this is not a stopping time. Instead, we define, for $i \in \{1, \dots, p\}$,

$$t_i^\pi = \inf \left\{ t \geq s_i^\pi : X_t \in d_i, \frac{1}{2\pi} |\tilde{\theta}_{\pi(i)}(t) - \tilde{\theta}_{\pi(i)}(s_i^\pi)| \geq \frac{M-1}{p} - 1 \right\}.$$

We also set $t_0^\pi = 0$. Then, for all $i \in \{1, \dots, p\}$, $t_i^\pi \in [s_i^\pi, s_{i+1}^\pi]$ and, as we suggested, t_i^π is expected to be close to s_{i+1}^π . We now write

$$\mathbb{P}(t_i^\pi < +\infty | t_{i-1}^\pi < +\infty) \leq \mathbb{P}(\exists s, t \in [t_{i-1}^\pi, 1] : \frac{1}{2\pi} |\tilde{\theta}_{\pi(i)}(t) - \tilde{\theta}_{\pi(i)}(s)| \geq \frac{M-1}{p} - 1 | t_{i-1}^\pi < +\infty).$$

We now use the fact that

$$|\tilde{\theta}_{\pi(i)}(t) - \tilde{\theta}_{\pi(i)}(s)| \leq |\tilde{\theta}_{\pi(i)}(t) - \tilde{\theta}_{\pi(i)}(t_{i-1}^\pi)| + |\tilde{\theta}_{\pi(i)}(s) - \tilde{\theta}_{\pi(i)}(t_{i-1}^\pi)|$$

to obtain that our conditional probability is not larger than

$$\mathbb{P}(\exists t \in [t_{i-1}^\pi, 1] : \frac{2}{2\pi} |\tilde{\theta}_{\pi(i)}(t) - \tilde{\theta}_{\pi(i)}(t_{i-1}^\pi)| \geq \frac{M-1}{p} - 1 | t_{i-1}^\pi < +\infty).$$

Since t_i^π is a stopping time¹, this is equal to

$$\frac{1}{\mathbb{P}(t_{i-1}^\pi < +\infty)} \mathbb{E}_0 \left[\mathbb{1}_{\{t_{i-1}^\pi < +\infty\}} \mathbb{E}_{X_{t_{i-1}^\pi}} \left[\mathbb{1}_{\left\{ \exists t \in [0, 1-t_{i-1}^\pi] : \frac{2}{2\pi} |\tilde{\theta}_{\pi(i)}(t) - \tilde{\theta}_{\pi(i)}(0)| \geq \frac{M-1}{p} - 1 \right\}} \right] \right].$$

¹This is for a *given* permutation π . If we set π^* the random permutation that appears on Sublemma 2.2.2, it is *false* that $t_i^{\pi^*}$ is a stopping time.

Since the distance between $X_{t_i^\pi}$ and $z_{\pi(i+1)}$ is at least the distance between $z_{\pi(i)}$ and $z_{\pi(i+1)}$, which is at least $M^{-\beta}$, the innermost expectation in the last expression, and hence the whole expression, is smaller than

$$\sup_{\|z\| \geq M^{-\beta}} \mathbb{P}_z(\exists t \in [0, 1] : \frac{1}{\pi} |\tilde{\theta}_{\pi(i)}(t)| \geq \frac{M-1}{p} - 1).$$

Using the scaling property of the Brownian motion, this is equal to

$$\mathbb{P}_{(1,0)}(\exists t \in [0, M^{2\beta}] : \frac{1}{\pi} |\tilde{\theta}_{X'}(t)| \geq \frac{M-1}{p} - 1)$$

where $X' : \mathbb{R}^+ \rightarrow \mathbb{R}^2$ is a Brownian motion started at $(1, 0)$, and $\tilde{\theta}_{X'}$ is the continuous determination of the angle around 0 and along X' , initialized to be 0 at time 0. Finally, we obtain

$$\begin{aligned} f_M^{(p)}(z_1, \dots, z_p) &\leq \sum_{\pi \in \mathcal{S}_p} \mathbb{P}(s_{p+1}^\pi < +\infty) \\ &\leq \sum_{\pi \in \mathcal{S}_p} \prod_{i=1}^p \mathbb{P}(t_i^\pi < +\infty | t_{i-1}^\pi < +\infty) \\ &= p! \mathbb{P}_{(1,0)}(\exists t \in [0, M^{2\beta}] : \frac{1}{\pi} |\tilde{\theta}_{X'_{[0,t]}}| \geq \frac{M-1}{p} - 1)^p, \end{aligned} \quad (2.3)$$

We now use the following bound, which can be found in page 117 in Shi's article [45]: for t and x positive reals such that $t \log(x)$ is large enough,

$$\mathbb{P}_{(1,0)}\left(\sup_{0 \leq u \leq t} \tilde{\theta}_{X'_{[0,u]}} \geq x\right) \leq \frac{8}{x} + \frac{2 \log(16t \log(x))}{x}. \quad (2.4)$$

We apply this inequality with $t = M^{2\beta}$ and $x = \pi(\frac{M-1}{p} - 1)$. For $z \notin B(0, M^{-\beta})$, $t \log(x)$ becomes arbitrarily large when M is large. Therefore, we can apply the inequality, at least when M is larger than some M_0 which does not depend on z . We end up with

$$\mathbb{P}_{(1,0)}(\exists t \in [0, M^{2\beta}] : \frac{1}{\pi} |\tilde{\theta}_{X'_{[0,t]}}| \geq \frac{M-1}{p} - 1) \leq C \log(M+1) M^{-1} \quad (2.5)$$

for some constant C which depends on β and p but not on M . This and (2.3) gives the announced bound. \square

From elementary computations, these inequalities give the following bounds.

Corollary 2.2.5. *For all $p, q \geq 1$, there exists C, C' such that for all $R > 0$ and all $M \geq 1$,*

$$\int_{(\mathbb{R}^2)^p \setminus B(0,R)^p} (f_M^{(p)}(\mathbf{z}))^q d\mathbf{z} \leq C e^{-\frac{q}{4p} R^2} \quad (2.6)$$

and

$$\int_{(\mathbb{R}^2)^p} f_M^{(p)}(\mathbf{z})^q d\mathbf{z} \leq C' \log(M+1)^{p(q+1)} M^{-pq}. \quad (2.7)$$

Proof. We denote by z_1, \dots, z_p the components of a generic $\mathbf{z} \in (\mathbb{R}^2)^p$. For each $r \in \{1, \dots, p\}$, we define the subset

$$E_r = \{\mathbf{z} : \|z_r\| \geq R\}$$

of $(\mathbb{R}^2)^p$, so that $(\mathbb{R}^2)^p \setminus B(0, R)^p = E_1 \cup \dots \cup E_p$.

For all $r \in \{1, \dots, p\}$ and $\mathbf{z} \in E_r$, we have shown in Sublemma 2.2.3 that

$$f_M^{(p)}(\mathbf{z}) \leq 4 \exp\left(-\frac{1}{4} \max\{\|z_r\|^2 : r \in \{1, \dots, p\}\}\right) \leq 4 \exp\left(-\frac{1}{4p} \sum_{r=1}^p \|z_r\|^2\right).$$

It follows that

$$\begin{aligned} \int_{E_r} f_M^{(p)}(\mathbf{z})^q \, d\mathbf{z} &\leq 4^q \int_{E_r} \exp\left(-\frac{q}{4p} \sum_{r=1}^p \|z_r\|^2\right) \, d\mathbf{z} \\ &= 4^q \left(\frac{4\pi p}{q}\right)^{p-1} \int_R^{+\infty} 2\pi \rho \exp\left(-\frac{q}{4p} \rho^2\right) \, d\rho \\ &= 4^q \left(\frac{4\pi p}{q}\right)^p e^{-\frac{q}{4p} R^2}. \end{aligned}$$

Summing over $r \in \{1, \dots, p\}$ gives the desired bound (2.6) (with $C = p4^q \left(\frac{4\pi p}{q}\right)^p$).

To prove (2.7), we set $R = 2p\sqrt{\log(M+1)}$, and we fix $\beta > \frac{pq}{2}$. We decompose $(\mathbb{R}^2)^p$ into

$$(B(0, R)^p \cap T_\beta) \cup (B(0, R)^p \setminus T_\beta) \cup (\mathbb{R}^2)^p \setminus B(0, R)^p.$$

We decompose the integral $\int_{(\mathbb{R}^2)^p} f_M^{(p)}(\mathbf{z})^q \, d\mathbf{z}$ accordingly. For the chosen value of R , using (2.6), we obtain, for some C ,

$$\int_{(\mathbb{R}^2)^p \setminus B(0, R)^p} f_M^{(p)}(\mathbf{z})^q \, d\mathbf{z} \leq CM^{-pq}.$$

Thus,

$$\begin{aligned} \int_{(\mathbb{R}^2)^p} f_M^{(p)}(\mathbf{z})^q \, d\mathbf{z} &\leq |B(0, R)^p \cap T_\beta| + C \log(M+1)^{pq} M^{-pq} |B(0, R)^p| + C'(M+1)^{-pq} \\ &\leq C''(\log(M+1))^p M^{-2\beta} + \log(M+1)^{p(q+1)} M^{-pq} + (M+1)^{-pq} \\ &\leq C^{(3)} \log(M+1)^{p(q+1)} M^{-pq}. \end{aligned}$$

This concludes the proof. \square

This technical estimation allows us to show the following lemma. Let us recall that X^i is the restriction of X to the interval $[\frac{i-1}{T}, \frac{i}{T}]$, and that

$$\begin{aligned} \mathcal{D}_{N,M}^{i,j} &= \{z \in \mathbb{R}^2 : |\theta^{X^i}(z)| \geq N, |\theta^{X^j}(z)| \geq M\}, \\ \mathcal{D}_M^{i,j,k} &= \{z \in \mathbb{R}^2 : |\theta^{X^i}(z)| \geq M, |\theta^{X^j}(z)| \geq M, |\theta^{X^k}(z)| \geq M\}, \end{aligned}$$

and that we denote with straight letters the Lebesgue measures of these sets.

Lemma 2.2.6. *For all positive integer p , there exists a constant C such that for all positive integers N, M and T and any $i, j \in \{1, \dots, T\}, i \neq j$,*

$$\mathbb{E}[(D_{N,M}^{i,j})^p] \leq C \log(NMT + 1)^{3p+1} \frac{(TNM)^{-p}}{|j-i|+1}.$$

In particular, for all positive integer p , there exists a constant C' such that for all positive integers N, M, T ,

$$\mathbb{E}\left[\left(\sum_{\substack{i,j=1 \\ i \neq j}}^T D_{N,M}^{i,j}\right)^p\right] \leq C' \log(NMT + 1)^{3p+2} T^{p-1} (NM)^{-p}.$$

Lemma 2.2.7. *For all positive integer p , there exists a finite constant C such that for all positive integers M, T and any $i < j < k \in \{1, \dots, T\}$,*

$$\mathbb{E}[(D_M^{i,j,k})^p] \leq C \log(MT + 1)^{4p+2} \frac{M^{-3p} T^{-p}}{(k-j+1)(j-i+1)}.$$

In particular, for all positive integer p , there exists a finite constant C such that for all positive integers N, M, T ,

$$\mathbb{E}\left[\left(\sum_{1 \leq i < j < k \leq T} D_M^{i,j,k}\right)^p\right] \leq C \log(MT + 1)^{4p+4} T^{2p-2} M^{-3p}.$$

Proof of Lemma 2.2.6. For all $z \in \mathbb{R}^2$, we set $\mathbf{z} - z = (z_1 - z, \dots, z_p - z)$. We assume $j > i$. For $t > 0$, we write $p_t(z) = (2\pi t)^{-1} \exp(-\frac{\|z\|^2}{2t})$ the heat kernel on \mathbb{R}^2 . For $t = 0$ (which will correspond to the special case $j = i + 1$), we allow ourselves to write $\int_{\mathbb{R}^2} p_t(z) f(z) dz$, which should be understood as $f(0)$.

Remark first that

$$\begin{aligned} \mathbb{E}_0[(D_{N,M}^{i,j})^p] &= \int_{(\mathbb{R}^2)^p} \mathbb{P}_0\left(\min_{r \in \{1, \dots, p\}} |\theta^{X^i}(z_r)| \geq N, \min_{r \in \{1, \dots, p\}} |\theta^{X^j}(z_r)| \geq M\right) d\mathbf{z} \\ &= \int_{(\mathbb{R}^2)^p} \mathbb{P}_0\left(\min_{r \in \{1, \dots, p\}} |\theta^{X^i - X_{T-1}^i}(z_r)| \geq N, \min_{r \in \{1, \dots, p\}} |\theta^{X^j - X_{T-1}^i}(z_r)| \geq M\right) d\mathbf{z}. \end{aligned}$$

The second equality is obtained by using the translation invariance of the Lebesgue measure and the property that $\theta^Y(z' + z) = \theta^{Y-z}(z')$ for all Y, z, z' .

The processes $X^i - X_{T-1}^i$ and $X^j - X_{T-1}^i$ are independent. The first one is a Brownian motion of duration T^{-1} starting at 0, and the other one is a Brownian motion of duration T^{-1} starting at a random point which is a centered Gaussian random variable with variance $(j-i-1)T^{-1}$. It follows that

$$\begin{aligned} &\mathbb{P}_0\left(\min_{r \in \{1, \dots, p\}} |\theta^{X^i - X_{T-1}^i}(z_r)| \geq N, \min_{r \in \{1, \dots, p\}} |\theta^{X^j - X_{T-1}^i}(z_r)| \geq M\right) \\ &= \mathbb{P}_0\left(\min_{r \in \{1, \dots, p\}} |\theta^{X^1}(z_r)| \geq N\right) \mathbb{P}_{\mathcal{N}(0, (j-i-1)T^{-1})}\left(\min_{r \in \{1, \dots, p\}} |\theta^{X^1}(z_r)| \geq M\right) \\ &= f^{(p)}(\sqrt{T}\mathbf{z}) \int_{\mathbb{R}^2} p_{(j-i-1)T^{-1}}(z) f^{(p)}(\sqrt{T}(\mathbf{z} - z)) dz. \end{aligned} \tag{2.8}$$

For the last equation, we used the scaling invariance of the Brownian motion. To be clear, we used the notation $\mathbb{P}_{\mathcal{N}(0,\sigma^2)}$ in the following sense:

$$\mathbb{P}_{\mathcal{N}(0,\sigma^2)}(\cdot) = \begin{cases} \mathbb{P}_0(\cdot) & \text{if } \sigma^2 = 0, \\ \int_{\mathbb{R}^2} e^{-\frac{\|z\|^2}{2\sigma^2}} \mathbb{P}_z(\cdot) \frac{dz}{2\pi\sigma^2} & \text{otherwise.} \end{cases}$$

We obtain

$$\begin{aligned} \mathbb{E}_0[(D_{N,M}^{i,j})^p] &= \int_{(\mathbb{R}^2)^p} f_N^{(p)}(\sqrt{T}\mathbf{z}) \int_{\mathbb{R}^2} p_{(j-i-1)T^{-1}}(z) f_M^{(p)}(\sqrt{T}(\mathbf{z}-z)) \, dz \\ &= T^{-p} \int_{(\mathbb{R}^2)^p} f_N^{(p)}(\mathbf{z}) \int_{\mathbb{R}^2} p_{j-i-1}(z) f_M^{(p)}(\mathbf{z}-z) \, dz \, d\mathbf{z}. \end{aligned}$$

We now treat the special case $j = i + 1$. In this case,

$$\begin{aligned} \mathbb{E}_0[(D_{N,M}^{i,i+1})^p] &= T^{-p} \int_{(\mathbb{R}^2)^p} f_N^{(p)}(\mathbf{z}) f_M^{(p)}(\mathbf{z}) \, d\mathbf{z} \\ &\leq T^{-p} \left(\int_{(\mathbb{R}^2)^p} f_N^{(p)}(\mathbf{z})^2 \, d\mathbf{z} \right)^{\frac{1}{2}} \left(\int_{(\mathbb{R}^2)^p} f_M^{(p)}(\mathbf{z})^2 \, d\mathbf{z} \right)^{\frac{1}{2}} \\ &\leq CT^{-p} \log(M+1)^{\frac{3p}{2}} \log(N+1)^{\frac{3p}{2}} M^{-p} N^{-p} \quad (\text{using (2.7)}). \end{aligned}$$

This is sufficient to conclude in this case. The same estimation is also valid for $j > i + 1$, but we want to obtain an extra factor $(j-i)^{-1}$. We now assume $j > i + 1$. We set

$$R = 2\sqrt{p \log(M^p N^p (j-i-1) + 1)}.$$

First, we have

$$\begin{aligned} \mathbb{E}_0[(D_{N,M}^{i,j})^p] &= T^{-p} \left(\int_{(\mathbb{R}^2)^p} \int_{B(0,2R)} + \int_{(B(0,R))^p} \int_{\mathbb{R}^2 \setminus B(0,2R)} + \int_{(\mathbb{R}^2)^p \setminus (B(0,R))^p} \int_{\mathbb{R}^2 \setminus B(0,2R)} \right) \\ &\quad f_N^{(p)}(\mathbf{z}) p_{j-i-1}(z) f_M^{(p)}(\mathbf{z}-z) \, dz \, d\mathbf{z} \\ &\leq T^{-p} \int_{B(0,2R)} \frac{1}{2\pi(j-i-1)} \int_{(\mathbb{R}^2)^p} f_N^{(p)}(\mathbf{z}) f_M^{(p)}(\mathbf{z}-z) \, d\mathbf{z} \, dz \\ &\quad + T^{-p} \int_{\mathbb{R}^2 \setminus B(0,2R)} p_{j-i-1}(z) \int_{(B(0,R))^p} f_M^{(p)}(\mathbf{z}-z) \, d\mathbf{z} \, dz \\ &\quad + T^{-p} \int_{\mathbb{R}^2 \setminus B(0,2R)} p_{j-i-1}(z) \int_{(\mathbb{R}^2)^p \setminus (B(0,R))^p} f_N^{(p)}(\mathbf{z}) \, d\mathbf{z} \, dz \\ &\leq T^{-p} \frac{4\pi R^2}{2\pi(j-i-1)} \left(\int_{(\mathbb{R}^2)^p} f_N^{(p)}(\mathbf{z})^2 \, d\mathbf{z} \right)^{\frac{1}{2}} \left(\int_{(\mathbb{R}^2)^p} f_M^{(p)}(\mathbf{z})^2 \, d\mathbf{z} \right)^{\frac{1}{2}} + 2C'T^{-p} e^{-\frac{R^2}{4p}}. \end{aligned}$$

For the first inequality, we used the bound $p_t(z) \leq (2\pi t)^{-1}$ (for the first integral), the bound $f_N^{(p)} \leq 1$ (for the second integral) and the bound $f_M^{(p)} \leq 1$ (for the third integral). For the second inequality, we used the Cauchy–Schwarz inequality (for the first integral), and the first inequality of Corollary 2.2.5 (for the two other integrals).

Using the second inequality of Corollary 2.2.5, we then obtain

$$\begin{aligned}\mathbb{E}_0[(D_{N,M}^{i,j})^p] &\leq CT^{-p}R^2(j-i-1)^{-1}\log(N+1)^{\frac{3p}{2}}\log(M+1)^{\frac{3p}{2}}(NM)^{-p}+2C'T^{-p}e^{-\frac{R^2}{4p}} \\ &\leq C'\log(NMT+1)^{3p+1}T^{-p}M^{-p}N^{-p}(j-i)^{-1}.\end{aligned}$$

This concludes the proof of the first inequality. The second one follows directly:

$$\begin{aligned}\mathbb{E}\left[\left(\sum_{i \neq j} D_{N,M}^{i,j}\right)^p\right] &\leq T^{2p-1} \sum_{1 \leq i < j \leq T} \mathbb{E}\left[(D_{N,M}^{i,j})^p\right] \\ &\leq CT^{p-1}M^{-p}N^{-p}\log(NMT+1)^{3p+1} \sum_{1 \leq i < j \leq T} (|j-i|+1)^{-1} \\ &\leq C'T^pM^{-p}N^{-p}\log(NMT+1)^{3p+2}\end{aligned}$$

This concludes the proof of Lemma 2.2.6. \square

Proof of Lemma 2.2.7. It is similar to the previous proof, and we skip some details. We restrict ourselves to the case $j \neq i+1$ and $k \neq j+1$. The three other cases ($j = i+1$ and $k \neq j+1$, $j \neq i+1$ and $k = j+1$, $j = i+1$ and $k = j+1$) are dealt with similarly – but with some simplifications. We set $R = 2\sqrt{p\log(M^{3p}(k-j-1)(j-i-1)+1)}$. We obtain

$$\begin{aligned}\mathbb{E}_0[(D_M^{i,j,k})^p] &= T^{-p} \int_{(\mathbb{R}^2)^p} f_M^{(p)}(\mathbf{z}) \int_{\mathbb{R}^2} p_{j-i-1}(z) f_M^{(p)}(\mathbf{z}-z) \int_{\mathbb{R}^2} p_{k-j-1}(z') f_M^{(p)}(\mathbf{z}-z-z') dz' dz d\mathbf{z}. \\ &= T^{-p} \left(\int_{(\mathbb{R}^2)^p} \int_{B(0,2R)^2} + \int_{(\mathbb{R}^2)^p \setminus B(0,R)^p} \int_{(\mathbb{R}^2)^2 \setminus B(0,2R)^2} + \int_{B(0,R)^p} \int_{(\mathbb{R}^2)^2 \setminus B(0,2R)^2} \right) \\ &\quad f_M^{(p)}(\mathbf{z}) p_{j-i-1}(z) f_M^{(p)}(\mathbf{z}-z) p_{k-j-1}(z') f_M^{(p)}(\mathbf{z}-z-z') dz' dz d\mathbf{z}.\end{aligned}$$

For the first term, we have

$$\begin{aligned}&\int_{(\mathbb{R}^2)^p} \int_{B(0,2R)^2} f_M^{(p)}(\mathbf{z}) p_{j-i-1}(z) f_M^{(p)}(\mathbf{z}-z) p_{k-j-1}(z') f_M^{(p)}(\mathbf{z}-z-z') dz' dz d\mathbf{z} \\ &\leq \frac{16\pi^2 R^4}{4\pi^2(k-j-1)(j-i-1)} \int_{(\mathbb{R}^2)^p} f_M^{(p)}(\mathbf{z})^3 d\mathbf{z} \\ &\leq CR^4(k-j-1)^{-1}(j-i-1)^{-1}\log(M+1)^{4p}M^{-3p} \quad (\text{using Corollary 2.2.5}) \\ &\leq C'\log(M(k-j)(j-i)+1)^2\log(M+1)^{4p}(k-j-1)^{-1}(j-i-1)^{-1}M^{-3p}.\end{aligned}$$

For the two other integrals, they are each smaller than

$$2 \int_{(\mathbb{R}^2)^p \setminus B(0,R)^p} f_M^{(p)}(\mathbf{z}) d\mathbf{z}.$$

The factor 2 comes from the decomposition

$$(\mathbb{R}^2)^2 \setminus B(0,R)^2 = \mathbb{R}^2 \times (\mathbb{R}^2 \setminus B(0,R)) \cup (\mathbb{R}^2 \setminus B(0,R)) \times \mathbb{R}^2.$$

By (2.6), these integrals are smaller than $Ce^{-\frac{R^2}{4p}} = C(M^{3p}(k-j-1)(j-i-1)+1)^{-1}$ for some constant C . Hence, we obtain

$$\mathbb{E}_0[(D_M^{i,j,k})^p] \leq C \log(M(k-j)(j-i)+1)^2 \log(M+1)^{4p} (k-j-1)^{-1} (j-i-1)^{-1} M^{-3p} T^{-p}.$$

This concludes for the first inequality in the lemma. For the second one, we have

$$\begin{aligned} \mathbb{E}_0 \left[\left(\sum_{1 \leq i < j < k \leq T} D_M^{i,j,k} \right)^p \right] &\leq T^{3p-3} \sum_{1 \leq i < j < k \leq T} \mathbb{E}_0 [(D_M^{i,j,k})^p] \\ &\leq C' \log(MT^2+1)^2 \log(M+1)^{4p} T^{2p-3} M^{-3p} \sum_{1 \leq i < j < k \leq T} (k-j)^{-1} (j-i)^{-1} \\ &\leq C'' \log(T+1)^2 \log(MT+1)^2 \log(M+1)^{4p} T^{2p-2} M^{-3p}. \end{aligned}$$

This concludes the proof of Lemma 2.2.7. \square

Remark 2.2.8. *The exponents in M and N in Corollary 2.2.5 and Lemmas 2.2.6 and 2.2.7 are optimal. In Corollary 2.2.5, the case $p = 2$, $q = 1$ follows from the convergence result obtained by W. Werner, and we can withdraw the logarithmic corrections in this case. For the general case, the same results without logarithmic corrections are likely to hold.*

This remark leads us to the following conjecture, the proof of which would require a much more careful analysis.

Conjecture 2.2.9. *Let $X_1, \dots, X_n : [0, 1] \rightarrow \mathbb{R}^2$ be n independent planar Brownian motions, and let $\theta^1, \dots, \theta^n$ be their winding functions. Let $\mathcal{D}_{N_1, \dots, N_n}^{(n)}$ be the set*

$$\mathcal{D}_{N_1, \dots, N_n}^{(n)} = \{z \in \mathbb{R}^2 : \forall i \in \{1, \dots, n\}, \theta^i(z) \geq N_i\}.$$

Then, the area $D_{N_1, \dots, N_n}^{(n)}$ of $\mathcal{D}_{N_1, \dots, N_n}^{(n)}$, multiplied by $N_1 \dots N_n$, converges (in some sense), as the N_i goes to infinity, toward a random variable which depends only on the intersection set

$$\{(t_1, \dots, t_n, X_{t_1}) : t_1, \dots, t_n \in [0, 1], X_{1, t_1} = \dots = X_{n, t_n}\}.$$

If such a convergence were to hold indeed, it would likely hold in L^p for all $p \in [1, +\infty)$, and in the almost sure sense. Remark that in the case $n = 1$, the convergence does hold, and the limit is a constant in this case (as opposed to the general one).

We conclude this section by giving without proof a variation on Lemma 2.2.6, that we will not use in this form, but that expresses the ideas of this section in a way that is perhaps easier to grasp than in the technical lemmas.

Proposition 2.2.10. *Let X and X' be two independent Brownian motions from $[0, 1]$ to \mathbb{R}^2 . Let*

$$\mathcal{D}_N^{(2)} = \{z \in \mathbb{R}^2 : \theta^X(z) \geq N, \theta^{X'}(z) \geq N\}.$$

Then, for all $p \in [1, +\infty)$, there exists a constant C such that for all $N \geq 1$,

$$\mathbb{E}[(D_N^{(2)})^p]^{\frac{1}{p}} \leq \log(N+1)^4 N^{-2}.$$

2.3 Asymptotics on average

Recall that D_N denotes the area of the set of points z for which the winding $\theta(z)$ of a brownian motion $X : [0, 1] \rightarrow \mathbb{R}^2$ is at least N . In this section, we will show the following estimation in mean.

Lemma 2.3.1. *As N tends to infinity,*

$$\mathbb{E}[D_N] = \frac{1}{2\pi N} + O(N^{-2}). \quad (2.9)$$

Proof. We use the complex coordinate z on the real plane \mathbb{R}^2 , and once again we denote by $\tilde{\theta}(z)$ the value at time 1 of the continuous determination of the angle of X around z , initialized to be 0 at time 0. It will be convenient here to study $\tilde{\theta}$ instead of the integer-valued winding number θ that we use in most of the paper. The reason is that, for a given z , explicit formulas are known about the law of $\tilde{\theta}(z)$. We recall that for all point $z \in \mathbb{R}^2$ for which $\theta^X(z)$ is well-defined, the quantities $\theta(z)$ and $\tilde{\theta}(z)$ are related by the bound

$$|\theta(z) - \frac{1}{2\pi}\tilde{\theta}(z)| \leq \frac{1}{2}. \quad (2.10)$$

It is also convenient to eliminate from our analysis the points on the plane which are very close from the starting point of our trajectory. Indeed, such points have a higher probability to have a large winding number. It is thus more convenient to simply bound this probability by 1 than to try to control this high probability. We thus introduce, for $N \geq 1$, the set

$$\tilde{\mathcal{D}}_N = \{z \in \mathbb{C} \setminus B(0, e^{-N}) : \tilde{\theta}(z) \geq 2\pi N\},$$

of which we denote the Lebesgue measure by \tilde{D}_N .

From (2.2), we deduce the following inclusions:

$$\tilde{\mathcal{D}}_{N+2} \subseteq \mathcal{D}_{N+1} \subseteq \tilde{\mathcal{D}}_N \cup B(0, e^{-N}) \subseteq \mathcal{D}_{N-1} \cup B(0, e^{-N}).$$

In particular,

$$\mathbb{E}[D_N] = \frac{1}{2\pi N} + O(N^{-2}) \iff \mathbb{E}[\tilde{D}_N] = \frac{1}{2\pi N} + O(N^{-2}).$$

We prove the right-hand side. First, we give an integral representation of the quantity $\mathbb{E}[\tilde{D}_N]$. We denote by I_0 the modified Bessel function of the first kind with parameter 0. The single thing about this function that we will need is the inequality $I_0(x) \geq 1$ for $x \geq 0$. Then, for $\phi > \pi$ and $\rho, r \geq 0$, Mansuy and Yor showed in [37] (Theorem 5.2) the following equality:

$$\mathbb{P}_r(\tilde{\theta}(0) \geq \phi \mid |X_1| = \rho) = \frac{1}{2\pi^2 I_0(r\rho)} \int_{\phi-\pi}^{\phi+\pi} \int_0^\infty e^{-r\rho \cosh(t)} \frac{x}{x^2 + t^2} dt dx. \quad (2.11)$$

Here of course, the conditioning corresponds to the disintegration with respect to the (continuous) density of X_1 . By integrating back with respect to ρ (with the appropriate density), we obtain:

$$\mathbb{P}_r(\tilde{\theta}(0) \geq \phi) = \frac{1}{2\pi^2} \int_0^\infty \frac{\rho}{I_0(r\rho)} \int_0^{2\pi} p_1(r, \rho e^{iu}) du \int_{\phi-\pi}^{\phi+\pi} \int_0^\infty e^{-r\rho \cosh(t)} \frac{x}{x^2 + t^2} dt dx d\rho.$$

Using the invariance of the Brownian motion with respect to translation, we have

$$\begin{aligned}
\mathbb{E}_0[\tilde{D}_N] &= \int_{\mathbb{C}^2 \setminus B(0, e^{-N})} \mathbb{P}_0(\tilde{\theta}(z) \geq 2\pi N) \, dz \\
&= 2\pi \int_{e^{-N}}^{\infty} r \mathbb{P}_r(\tilde{\theta}(0) \geq 2\pi N) \, dr \\
&= \frac{1}{\pi} \int_{e^{-N}}^{\infty} r \int_0^{\infty} \frac{\rho}{I_0(r\rho)} \int_0^{2\pi} p_1(r, \rho e^{iu}) \, du \int_{(2N-1)\pi}^{(2N+1)\pi} \int_0^{\infty} e^{-r\rho \cosh(t)} \frac{x}{x^2 + t^2} \, dt \, dx \, d\rho \, dr. \quad (2.12)
\end{aligned}$$

Roughly speaking, on the asymptotic regime $N \rightarrow +\infty$, we have $x \simeq 2\pi N \rightarrow +\infty$ and we expect that $\frac{x}{x^2+t^2} \simeq \frac{1}{x}$. We also expect that the bound e^{-N} can freely be replaced with 0. The multiple integral (2.12) then decouples into

$$A \int_{(2N-1)\pi}^{(2N+1)\pi} \frac{dx}{x} \quad \text{with} \quad A = \frac{1}{\pi} \int_0^{\infty} r \int_0^{\infty} \frac{\rho}{I_0(r\rho)} \int_0^{2\pi} p_1(r, \rho e^{iu}) \, du \int_0^{\infty} e^{-r\rho \cosh(t)} \, dt \, d\rho \, dr. \quad (2.13)$$

The reader might be puzzled by the fact we first introduced a kind of ‘‘cutoff’’ e^{-N} in the definition of \tilde{D}_N to then remove it with computations. The thing is we remove the cutoff *after* we replace $\frac{x}{x^2+t^2}$ with $\frac{1}{x}$. The rest of this proof consists on a lengthy but elementary computation to show that the difference between (2.12) and (2.13) is a $O(N^{-2})$.

We denote by I_N the right-hand side of (2.12) but with $\frac{1}{x^2+t^2}$ replaced by $\frac{1}{x^2}$. Set $\delta_N = I_N - \mathbb{E}_0[\tilde{D}_N]$. That is,

$$\delta_N = \frac{1}{\pi} \int_{e^{-N}}^{\infty} r \int_0^{\infty} \frac{\rho}{I_0(r\rho)} \int_0^{2\pi} p_1(r, \rho e^{iu}) \, du \int_{(2N-1)\pi}^{(2N+1)\pi} \int_0^{\infty} e^{-r\rho \cosh(t)} \frac{t^2}{x(x^2 + t^2)} \, dt \, dx \, d\rho \, dr.$$

Observe that $\delta_N \geq 0$. We decompose δ_N as $\delta_N^1 + \delta_N^2$ by splitting the first integral, with respect to r , at $r = 1$:

$$\delta_N^1 = \frac{1}{\pi} \int_{e^{-N}}^1 \dots \, dr \quad \text{and} \quad \delta_N^2 = \frac{1}{\pi} \int_1^{\infty} \dots \, dr.$$

To estimate δ_N^1 , we use the bounds

$$p_1(x, y) \leq p_1(0, 0); \quad \frac{1}{x^2 + t^2} \leq \frac{1}{x^2}; \quad \int_{(2N-1)\pi}^{(2N+1)\pi} \frac{dx}{x^3} \leq \frac{2\pi}{((2N-1)\pi)^3}; \quad I_0(r\rho) \geq 1.$$

Integrating then with respect to ρ , t and finally r , we obtain

$$\begin{aligned}
\delta_N^1 &\leq \frac{2\pi}{\pi} p_1(0, 0) \frac{2\pi}{((2N-1)\pi)^3} \int_{e^{-N}}^1 r \int_0^{\infty} \rho \int_0^{\infty} e^{-r\rho \cosh(t)} t^2 \, dt \, d\rho \, dr \\
&= O(N^{-3}) \int_{e^{-N}}^1 r \int_0^{\infty} \frac{t^2}{(r \cosh(t))^2} \, dt \, dr \\
&= O(N^{-2}).
\end{aligned}$$

To estimate δ_N^2 , we also use the bounds $e^{-r\rho \cosh(t)} \leq e^{-\rho \cosh(t)}$ (for $r \geq 1$) and $\int_{\mathbb{C}} p_t(x, y) dy = 1$. We then obtain

$$\delta_N^2 \leq \frac{2}{(2\pi(2N-1))^3} \int_0^\infty \rho \int_0^\infty e^{-\rho \cosh(t)} t^2 dt d\rho.$$

Computing first the integral on ρ , we obtain

$$\delta_N^2 = O(N^{-3}) \int_0^\infty \frac{t^2}{\cosh(t)^2} dt.$$

The remaining integral is clearly finite. We conclude that $\delta_N = O(N^{-2})$, that is, $\mathbb{E}_0[\tilde{D}_N] = I_N + O(N^{-2})$. We now wish to eliminate the cutoff, that is to replace I_N with $I_N + J_N$ where

$$J_N = \int_0^{e^{-N}} \dots dr.$$

Remark that $I_N + J_N$ is, as we hoped, exactly the right-hand side of (2.13). Inverting the integrals on the definition of J , we can write it

$$J_N = \int_0^\infty \dots d\rho.$$

and we then split the integral with respect to ρ at $\rho = 1$. We thus define

$$\begin{aligned} J_N^1 &= \int_0^{e^{-N}} \int_0^1 \frac{r\rho}{I_0(r\rho)} \int_0^{2\pi} p_1(r, \rho e^{iu}) du \int_0^\infty e^{-r\rho \cosh(t)} dt d\rho dr \\ J_N^2 &= \int_0^{e^{-N}} \int_1^\infty \frac{r\rho}{I_0(r\rho)} \int_0^{2\pi} p_1(r, \rho e^{iu}) du \int_0^\infty e^{-r\rho \cosh(t)} dt d\rho dr, \end{aligned}$$

and we have

$$J_N = (J_N^1 + J_N^2) \log \frac{2N+1}{2N-1}.$$

We will use the following estimation: there exists some finite C such that for all $\rho \in (0, \frac{1}{\cosh(1)})$,

$$f(\rho) = \int_0^{+\infty} \frac{1 - (1 + \rho \cosh(t))e^{-\rho \cosh(t)}}{\rho^2 \cosh(t)^2} dt \leq C + 2 \ln(\rho^{-1}). \quad (2.14)$$

We use now this inequality and we postpone its computation to the end of the proof. Using the

facts that p_1 is maximal at $(0, 0)$, and that $I_0 \geq 1$, we have

$$\begin{aligned}
J_N^1 &\leq 2\pi p_1(0, 0) \int_0^{e^{-N}} \int_0^1 r \rho \int_0^\infty e^{-r\rho \cosh(t)} dt d\rho dr \\
&\leq \int_0^{e^{-N}} \int_0^r u \int_0^\infty e^{-u \cosh(t)} dt \frac{du}{r} dr \quad (u = r\rho) \\
&= \int_0^{e^{-N}} \int_0^\infty \frac{1 - (1 + r \cosh(t))e^{-r \cosh(t)}}{r \cosh(t)^2} dt dr \quad (\text{computing the integral on } u.). \\
&= \int_0^{e^{-N}} r f(r) dr \\
&\leq \int_0^{e^{-N}} r(C + 2 \log(r^{-1})) dr \\
&= O(Ne^{-2N}).
\end{aligned}$$

For J_N^2 , since $\rho \geq 1$ inside the integral, we can bound $e^{-r\rho \cosh(t)}$ by $e^{-r \cosh(t)}$. Then, we have

$$\begin{aligned}
J_N^2 &\leq \int_0^{e^{-N}} r \left[\int_0^{2\pi} \int_0^\infty p_1(r, \rho e^{iu}) \rho d\rho du \right] \int_0^\infty e^{-r \cosh(t)} dt dr \\
&= \int_0^{e^{-N}} \int_0^\infty r e^{-r \cosh(t)} dt dr \\
&= \int_0^\infty \frac{1 - (1 + e^{-N} \cosh(t))e^{-e^{-N} \cosh(t)}}{\cosh(t)^2} dt \quad (\text{computing the integral on } r) \\
&= e^{-2N} f(e^{-N}) \\
&= O(Ne^{-2N}).
\end{aligned}$$

From this, we deduce in particular that $J_N = O(N^{-2})$ and finally that

$$\mathbb{E}[D_N] = A \int_{(2N-1)\pi}^{(2N+1)\pi} \frac{dx}{x} + O(N^{-2}) = \frac{A}{N} + O(N^{-2}).$$

Wiener's estimate on D_N gives $\mathbb{E}[D_N] = \frac{1}{2\pi N} + o(\frac{1}{N})$. It follows that $A = \frac{1}{2\pi}$ and that

$$\mathbb{E}[D_N] = \frac{1}{2\pi N} + O(N^{-2}).$$

To conclude the proof, we only need to show the inequality (2.14). It is easily proven that, for all $\rho, t \geq 0$,

$$0 \leq 1 - (1 + \rho \cosh(t))e^{-\rho \cosh(t)} \leq \rho^2 \cosh(t)^2.$$

For $t \geq 1$, we also have $2 \sinh(t) \geq \cosh(t)$. Thus, we have

$$\begin{aligned}
f(\rho) &= \int_0^1 \frac{1 - (1 + \rho \cosh(t))e^{-\rho \cosh(t)}}{\rho^2 \cosh(t)^2} dt + \int_1^{+\infty} \frac{1 - (1 + \rho \cosh(t))e^{-\rho \cosh(t)}}{\rho^2 \cosh(t)^2} dt \\
&\leq 1 + \int_1^{+\infty} \frac{1 - (1 + \rho \cosh(t))e^{-\rho \cosh(t)}}{\rho^2 \cosh(t)^2} \frac{2\rho \sinh(t)}{\rho \cosh(t)} dt \\
&= 1 + 2 \int_{\rho \cosh(1)}^{+\infty} \frac{1 - (1 + u)e^{-u}}{u^3} du \quad (u = \rho \cosh(t)) \\
&= 1 + 2 \int_{\rho \cosh(1)}^1 \frac{1 - (1 + u)e^{-u}}{u^3} du + 2 \int_1^{+\infty} \frac{1 - (1 + u)e^{-u}}{u^3} du.
\end{aligned}$$

Because of the exponential decay, the last integral is finite. Using $e^{-u} \geq 1 - u$, we then obtain, for some finite C ,

$$\begin{aligned}
f(\rho) &\leq C + 2 \int_{\rho \cosh(1)}^1 \frac{1 - (1 + u)(1 - u)}{u^3} du \\
&= C + 2 \int_{\rho \cosh(1)}^1 \frac{1}{u} du \\
&= C + 2 \ln(\rho^{-1} \cosh(1)) \\
&= C' + 2 \ln(\rho^{-1}).
\end{aligned}$$

This is the announced inequality. □

Remark 2.3.2. *If we replace the Brownian motion with a Brownian loop, the integrals on u and ρ disappear (it is the case $\rho = 0$), and the Bessel function reduces to 1. In that case, Garban and Ferreras obtained in [21, Theorem 5.2] the exact value*

$$\mathbb{E}_{x,x,1}[A_N] = \frac{1}{2\pi N^2}.$$

Their computation also uses the explicit expression (2.11) given by Mansuy and Yor. They then compute the integrals by performing a residue computation.

Remark 2.3.3. *With a much simpler computation, we also obtain, for every $z \neq 0$ the estimate $\mathbb{P}_0(\theta(z) \geq N) = \frac{C_z}{N} + O(N^{-2})$. Our estimate (2.9) does not follow from this simpler estimation, since the remainder is not uniform near $z = 0$.*

2.4 Asymptotics in L^2

In this section, we finally prove the promised estimation $\mathbb{E}[(ND_N - \frac{1}{2\pi})^2]^{\frac{1}{2}} \leq N^{-\frac{1}{2}+o(1)}$. We start by showing some inclusions which are deterministic.

2.4.1 Decomposition into small pieces

Let $Y : [0, 1] \rightarrow \mathbb{R}^2$ be continuous, and such that its range has vanishing Lebesgue measure. We will introduce a decomposition that allows us to relate the large winding set for Y with the large winding sets of different pieces of Y . Two inclusions are obtained here, and will be used again many times during the paper. Though we show them in a general framework, we first explain briefly how we will use them.

We fix three positive *large* integers N, M and T , such that $3T(M+1) < N$. Typically, T and M will be (the integer part of) some fractional power of N . The integer T will be the number of pieces we cut the curve into: we will write Y as the concatenation $Y^1 \cdots Y^T$, where Y^i is the restriction of Y to the interval $[\frac{i-1}{T}, \frac{i}{T}]$. Using the self-similarity of the Brownian motion, the inclusions will induce inequalities in distribution satisfied by the large winding set of the Brownian motion. The integer M is used as a barrier between two different situations. Basically, we want it to be large enough that one can asymptotically neglect the set of points around which two different pieces both wind at least M times, but we also want TM to be as small as possible compared to N . We invite the reader to always keep in mind the idea that when a Brownian path winds a lot around some point, only a small piece of the path is responsible for almost all of these windings.

We now start a rigorous reasoning. Let us introduce some notations. Let N, M, T be three integers such that $\frac{2N}{3} + (T-2)M \leq N - T$ (in particular, this holds when $3T(M+1) \leq N$). Set $0 = t_0 < \cdots < t_T = 1$. Set also Y^i the restriction of Y to $[t_{i-1}, t_i]$. We denote by Y^{pl} the piecewise linear curve with interpolation times t_0, \dots, t_T . That is, for $i \in \{1, \dots, T\}$ and $u \in [0, 1)$,

$$Y^{pl}(t_{i-1} + u(t_i - t_{i-1})) = Y(t_{i-1}) + u(Y(t_i) - Y(t_{i-1})).$$

We denote the function θ^{Y^i} by θ^i . The following equality of measurable functions holds almost everywhere:

$$\theta^Y = \theta^{Y^{pl}} + \sum_{i=1}^T \theta^i.$$

It actually holds pointwise at any point $z \in \mathbb{R}^2$ which does not lie on the range of Y , nor on the range of Y^{pl} , nor on the segment between Y_0 and Y_1 . We fix such a z , and we assume that it satisfies $\theta^Y(z) \geq N$.

It is easy to see that $|\theta^{Y^{pl}}|$ is bounded by $\frac{T}{2}$, hence by T . This implies $\sum_{i=1}^T \theta^i(z) \geq N - T$. It is easily proved that at least one of the three following possibilities necessarily holds:

- ◊ There exists $i \in \{1, \dots, T\}$ such that $\theta^i(z) \geq N - T - M(T-1) \geq N - T(M+1)$.
- ◊ There exists $i, j \in \{1, \dots, T\}, i \neq j$ such that $\theta^i(z) \geq \frac{N}{3}, \theta^j(z) \geq M$.
- ◊ There exists $i, j, k \in \{1, \dots, T\}, i < j < k$ such that $\theta^i(z) \geq M, \theta^j(z) \geq M$ and $\theta^k(z) \geq M$.

Indeed, let us denote by η_1, \dots, η_T the values $\theta^1(z), \dots, \theta^T(z)$ ordered decreasingly. Assuming that none of three possibilities hold, we get that $\eta_1 < N - T - M(T-1)$, $\eta_3 < M$, and either

$\eta_1 < \frac{N}{3}$ or $\eta_2 < M$. In the first case,

$$\sum_{i=1}^T \theta^i(z) = \sum_{i=1}^T \eta_i < \frac{N}{3} + \frac{N}{3} + (T-2)M \leq N - T,$$

which is absurd. In the second case,

$$\sum_{i=1}^T \theta^i(z) = \sum_{i=1}^T \eta_i < N - T - M(T-1) + (T-1)M = N - T,$$

which is absurd.

Let us set

$$\begin{aligned} \mathcal{D}_N &= \{z \in \mathbb{R}^2 : \theta^Y(z) \geq N\}, \\ \mathcal{D}_N^i &= \{z \in \mathbb{R}^2 : \theta^i(z) \geq N\}, \\ \mathcal{D}_{N,M}^{Y,i,j} &= \{z \in \mathbb{R}^2 : |\theta^i(z)| \geq N, |\theta^j(z)| \geq M\}, \\ \mathcal{D}_M^{i,j,k}(Y) &= \{z \in \mathbb{R}^2 : |\theta^i(z)| \geq M, |\theta^j(z)| \geq M, |\theta^k(z)| \geq M\}. \end{aligned}$$

This corresponds with the previous notations when $Y = X$. The previous reasoning translates into the following inclusion, up to a Lebesgue negligible set.

$$\mathcal{D}_N \subseteq \bigcup_{i=1}^T \mathcal{D}_{N-T(M+1)}^i \cup \bigcup_{i \neq j} \mathcal{D}_{\frac{N}{3}, M}^{i,j} \cup \bigcup_{i < j < k} \mathcal{D}_M^{i,j,k}. \quad (2.15)$$

Similarly, if there exists some index $i \in \{1, \dots, T\}$ such that $\theta^i(z) \geq N + (M+1)T$, then either there exists $j \neq i$ such that $\theta^j(z) \leq -M$ or $\theta^Y \geq N$. We deduce that, up to a Lebesgue negligible set,

$$\mathcal{D}_N \supseteq \bigcup_{i=1}^T \mathcal{D}_{N+T(M+1)}^i \setminus \bigcup_{i \neq j} \mathcal{D}_{\frac{N}{3}, M}^{i,j}. \quad (2.16)$$

Remark also that for all $i \neq j$,

$$\mathcal{D}_{N+T(M+1)}^i \cap \mathcal{D}_{N+T(M+1)}^j \subseteq \mathcal{D}_{\frac{N}{3}, M}^{i,j}. \quad (2.17)$$

From the inclusions (2.15), (2.16) and (2.17), we obtain the following result.

Lemma 2.4.1. *Let μ be a measure on the plane which is absolutely continuous with respect to the Lebesgue measure, and $Y : [0, 1] \rightarrow \mathbb{R}^2$ a continuous function whose range has vanishing Lebesgue measure. Then, for all positive integers N, T, M such that $T(M+1) < N$,*

$$\begin{aligned} \sum_{i=1}^T \mu(\mathcal{D}_{N+T(M+1)}^i) - \sum_{i \neq j} \mu(\mathcal{D}_{\frac{N}{3}, M}^{i,j}) &\leq \mu(\mathcal{D}_N) \\ &\leq \sum_{i=1}^T \mu(\mathcal{D}_{\frac{N}{3}-T(M+1)}^i) + \sum_{i \neq j} \mu(\mathcal{D}_{\frac{N}{3}, M}^{i,j}) + \sum_{i < j < k} \mu(\mathcal{D}_M^{i,j,k}). \end{aligned} \quad (2.18)$$

2.4.2 Asymptotic for the variation

We can now prove the following estimation.

Lemma 2.4.2.

$$\text{Var}[ND_N] \leq N^{-1+o(1)}.$$

Proof. We write $d_N = \mathbb{E}[D_N]$, and x_+ (resp. x_-) for the positive (resp. negative) part of a real number x . We also set $N^+ = N + T(M + 1)$, and $N^- = N - T(M + 1)$. The value of M and T will be given later on by $M = \lfloor N^{\frac{1}{2}} \rfloor$ and $T = \lfloor N^t \rfloor$ for some positive exponent t , so that N^+ and N^- only depends on N . Besides, we assume that $t < \frac{1}{2}$ so that

$$N^+ \underset{N \rightarrow +\infty}{\sim} N \underset{N \rightarrow +\infty}{\sim} N^-.$$

We advise the reader to simply think of M and T as \sqrt{N} and N^t , the integer values being there only for technical reasons. Besides, the reason why we take $M = \lfloor N^{\frac{1}{2}} \rfloor$ becomes clear only after the computation are complete. Thus, we will write $M = \lfloor N^m \rfloor$ during the proof, and only at the end of the proof we will write $m = \frac{1}{2}$.

We know from (2.18) that

$$D_N \leq \sum_{i=1}^T D_{N^-}^i + \sum_{i \neq j} D_{\frac{N}{3}, M}^{i,j} + \sum_{i < j < k} D_M^{i,j,k}$$

so that

$$N(D_N - d_N) \leq N \sum_{i=1}^T (D_{N^-}^i - \frac{d_{N^-}}{T}) + N(d_{N^-} - d_N) + N \sum_{i \neq j} D_{\frac{N}{3}, M}^{i,j} + N \sum_{i < j < k} D_M^{i,j,k}.$$

Taking positive parts, squares, and expectations, and using the identity

$$(a + b + c + d)^2 \leq 4(a^2 + b^2 + c^2 + d^2),$$

we obtain

$$\begin{aligned} \mathbb{E}_x \left[(N(D_N - d_N)_+)^2 \right] &\leq 4 \text{Var} \left[\sum_{i=1}^T ND_{N^-}^i \right] + 4N^2(d_N - d_{N^-})^2 + 4N^2 \mathbb{E} \left[\left(\sum_{i \neq j} D_{\frac{N}{3}, M}^{i,j} \right)^2 \right] \\ &\quad + 4N^2 \mathbb{E} \left[\left(\sum_{i < j < k} D_M^{i,j,k} \right)^2 \right] \end{aligned} \quad (2.19)$$

Using the Markov property, scale invariance and translation invariance of the Brownian motion, as well as the translation invariance of the Lebesgue measure, we deduce that the variables $D_{N^-}^i$ are i.i.d. and distributed as $T^{-1}D_{N^-}$. It follows that

$$\text{Var} \left[\sum_{i=1}^T ND_{N^-}^i \right] = T^{-1} \text{Var}[ND_{N^-}].$$

The factor T^{-1} that appears here is the core of the proof: the sum of the fluctuations of the $D_{N^-}^i$ is of lesser order than the sum of the absolute values of these fluctuations. This is why D_N itself has very small fluctuations.

We now apply Lemma 2.2.6 and 2.2.7 (with $p = 2$). With the specific choices of M and T we made, it reduces to the following. There exists a finite constant C such that for all positive integer N ,

$$\mathbb{E}\left[\left(\sum_{i \neq j} D_{\frac{N}{3}, M}^{i,j}\right)^2\right] \leq C \log(N+1)^8 N^{-2-2m+t}$$

and

$$\mathbb{E}\left[\left(\sum_{i < j < k} D_M^{i,j,k}\right)^2\right] \leq C \log(N+1)^{12} N^{-6m+2t}.$$

Finally, we need to control $d_N - d_{N^-}$. There is two possible methods for this. The first one is to summon the convergence shown by W. Werner,

$$N^2 |\{z \in \mathbb{R}^2 : \theta^B(z) = N\}| \xrightarrow{N \rightarrow +\infty} \frac{L^2}{2\pi}. \quad (2.20)$$

It implies that there exists a constant C such that for all positive integer n , $d_n \leq \frac{C}{n^2}$, and we sum from $n = N^-$ to $N - 1$. We obtain that for some constant C , for all positive integer N , $d_{N^-} - d_N \leq C' MTN^{-2}$.

The other method is to use Lemma 2.3.1:

$$\mathbb{E}[D_N] = \frac{1}{2\pi N} + O(N^{-2}).$$

We deduce that

$$d_{N^-} - d_N \sim \frac{1}{2\pi} MTN^{-2} \sim \frac{1}{2\pi} N^{m+t-2}.$$

Finally, (2.19) gives the following inequality, for some constant C , for all positive integer N :

$$\begin{aligned} \mathbb{E}_x \left[\left(N(D_N - d_N)_+ \right)^2 \right] &\leq 4T^{-1} \text{Var}[ND_{N^-}] + CN^{2m+2t-4} \\ &\quad + C \log(N+1)^8 N^{-2m+t} + C \log(N+1)^{12} N^{2-6m+2t}. \end{aligned}$$

The negative part is bounded in a similar but slightly simpler way. with $m = \frac{1}{2}$, we obtain

$$\text{Var}[ND_N] \leq N^{-t+o(1)} \text{Var}[N^- D_{N^-}] + O(N^{-1+2t}). \quad (2.21)$$

Such an equation is very much what we have in mind when we speak of the bootstrap. The idea then is that, starting with some asymptotic bound on $\text{Var}[D_N]$, we can put it on the right-hand side of the equation and hope that it will lead to a *better* asymptotic bound. The correction term, here the $O(N^{-1+2t})$, is made small by taking t close to 0. Since the bound is improved by a factor N^{-t} , the improvement is very small if t is close to 0, but we can ‘improve’ as many time as we want. This is traduced by the following claim.

Claim 2.4.3. *Let $t \in (0, \frac{1}{2})$. For all $k \in \mathbb{N}$, $\text{Var}[ND_N] \leq N^{-kt+o(1)} + O(N^{-1+2t})$.*

This is proved with a simple induction. For $k = 0$, it follows directly from the estimation (2) of W.Werner. If it is true for some k , we apply (2.21), and we get

$$\text{Var}[ND_N] \leq N^{-t+o(1)} \text{Var}[N^- D_{N^-}] + O(N^{-1+2t}) \leq N^{-(k+1)t+o(1)} + O(N^{-1+2t}).$$

This proves the claim. Applied with $k > t^{-1}$, it gives $\text{Var}[ND_N] \leq O(N^{-1+2t})$. Since t is arbitrary small, this is the same as $\text{Var}[ND_N] \leq N^{-1+o(1)}$, which concludes the proof. \square

2.5 Asymptotics in L^p

In order to extend the result of the previous section from L^2 to L^p , that it in order to obtain

$$\mathbb{E}[(ND_N - \frac{1}{2\pi})^p] \leq N^{-\frac{1}{2}+o(1)},$$

we could assume that p is integer and try to proceed in a similar, but more complicated, fashion.² Instead of that, we will simply look at the large deviations of ND_N around its expected value.

Lemma 2.5.1. *For all $k > 0$ and $\varepsilon > 0$, there is a constant C such that for all $N \in \mathbb{N}^*$,*

$$\mathbb{P}(|ND_N - \frac{1}{2\pi}| \geq N^{-\frac{1}{2}+\varepsilon}) \leq CN^{-k}. \quad (2.22)$$

Proof. The proof happens to be simpler if we treat separately the simple case $\varepsilon > \frac{1}{2}$. In this case, for all integer p , there exists a constant C such that for all positive integer N ,

$$\begin{aligned} \mathbb{P}(|ND_N - \frac{1}{2\pi}| \geq N^{-\frac{1}{2}+\varepsilon}) &\leq N^{\frac{p}{2}-p\varepsilon} 2^{p-1} (N^p \mathbb{E}[D_N^p] + (2\pi)^{-p}) \\ &= N^{\frac{p}{2}-p\varepsilon} 2^{p-1} (N^p \int_{(\mathbb{R}^2)^p} f_N^{(p)}(\mathbf{z}) \, d\mathbf{z} + (2\pi)^{-p}) \quad (\text{using the notation of Sublemma 2.2.3}) \\ &\leq N^{\frac{p}{2}-p\varepsilon} 2^{p-1} (C \log(N+1)^p + (2\pi)^{-p}) \quad (\text{using Corollary 2.2.5}). \end{aligned}$$

Since $\varepsilon > \frac{1}{2}$, it suffices to take p large enough to get the desired result.

For the general case, we use a bootstrap again. The idea is that for D_N to be very far from its expectation, there must be either one index i such that D_N^i is even further from its expectation, or at least two indices $i \neq j$ such that both D_N^i and D_N^j are far from their expectation.

For a positive real number x , set

$$p_{x,\varepsilon,C} = \mathbb{P}(|xD_{[x]} - \frac{1}{2\pi}| \geq C(\lceil x \rceil)^{-\frac{1}{2}+\varepsilon}).$$

We define this for possibly non-integer values x in order to avoid some additional constants to appear.

We set $u_0 = \frac{3}{2}$, and $u_{n+1} = \min(u_n + \frac{u_n-1}{2}, 2u_n - 1)$. It is not difficult to show that the sequence u_n is increasing, and then that it is unbounded.

We proceed by induction, the induction hypothesis being the following:

For all $\varepsilon > 0$ and all $C > 0$, there exists C' such that for all $N \geq 1$, $p_{N,\varepsilon,C} \leq C'N^{-u_n\varepsilon}$. (IH_n)

Since u_n is unbounded, concluding the induction would prove the lemma.

For $n = 0$, we simply use the Markov inequality and the convergence result we proved in L^2 :

$$\mathbb{P}(|xD_{[x]} - \frac{1}{2\pi}| \geq C(\lceil x \rceil)^{-\frac{1}{2}+\varepsilon}) \leq C^{-2}(\lceil x \rceil)^{1-2\varepsilon} \mathbb{E}[|xD_{[x]} - \frac{1}{2\pi}|^2] \leq x^{-2\varepsilon+o(1)}.$$

We now show that the hypothesis at rank n implies the one at rank $n+1$. First, for the case $\varepsilon > \frac{1}{2}$, we have already shown the lemma and hence the hypothesis (IH_n) does hold at any

²We don't know if this alternative proof would works.

rank and hence at rank $n + 1$. We now assume that $\varepsilon \leq \frac{1}{2}$. we set $m = \frac{1}{2}$ and $t = \frac{\varepsilon}{2}$, as well as $T = \lfloor N^t \rfloor$ and $M = \lfloor N^m \rfloor$. Remark that $m + t < 1$ as soon as $\varepsilon < 1$.

Since $D_N \leq \sum_{i=1}^T D_{N^-}^i + \sum_{1 \leq i < j \leq T} D_{M,M}^{i,j}$, we have

$$\begin{aligned} \mathbb{P}(ND_N - \frac{1}{2\pi} \geq CN^{-\frac{1}{2}+\varepsilon}) &\leq \mathbb{P}\left(\sum_{i=1}^T (ND_{N^-}^i - \frac{1}{2\pi T}) + \sum_{i < j} D_{M,M}^{i,j} \geq CN^{-\frac{1}{2}+\varepsilon}\right) \\ &\leq \mathbb{P}\left(\sum_{i=1}^T (ND_{N^-}^i - \frac{1}{2\pi T}) \geq \frac{C}{2}N^{-\frac{1}{2}+\varepsilon}\right) + \mathbb{P}\left(\sum_{i < j} D_{M,M}^{i,j} \geq \frac{C}{2}N^{-\frac{1}{2}+\varepsilon}\right). \end{aligned}$$

The first term is bounded as follows.

$$\begin{aligned} \mathbb{P}\left(\sum_{i=1}^T (ND_{N^-}^i - \frac{1}{2\pi T}) \geq \frac{C}{2}N^{-\frac{1}{2}+\varepsilon}\right) &\leq \mathbb{P}(\exists i \in \{1, \dots, T\} : ND_{N^-}^i - \frac{1}{2\pi T} \geq \frac{C}{4}N^{-\frac{1}{2}+\varepsilon}) \\ &+ \mathbb{P}(\exists i \neq j \in \{1, \dots, T\} : ND_{N^-}^i - \frac{1}{2\pi T} \geq \frac{C}{4}T^{-1}N^{-\frac{1}{2}+\varepsilon} \text{ and } ND_{N^-}^j - \frac{1}{2\pi T} \geq \frac{C}{4}T^{-1}N^{-\frac{1}{2}+\varepsilon}) \\ &\leq T\mathbb{P}(ND_{N^-} - \frac{1}{2\pi} \geq \frac{C}{4}TN^{-\frac{1}{2}+\varepsilon}) + T^2\mathbb{P}(ND_{N^-} - \frac{1}{2\pi} \geq \frac{C}{4}N^{-\frac{1}{2}+\varepsilon})^2. \end{aligned}$$

The last inequality is obtained by using the scaling properties of the Brownian motion, as well as its Markov property (which ensures that $D_{N^-}^i$ and $D_{N^-}^j$ are independent for $i \neq j$).

A simple computation gives

$$\mathbb{P}(ND_{N^-} - \frac{1}{2\pi} \geq \frac{C}{4}N^{-\frac{1}{2}+\varepsilon}) = \mathbb{P}(N^-D_{N^-} - \frac{1}{2\pi} \geq \frac{C}{4}\frac{N^-}{N}N^{-\frac{1}{2}+\varepsilon} - \frac{N-N^-}{2\pi N}).$$

With the chosen values of t and m , it is true that $1 - m - t > \frac{1}{2} - \varepsilon$ so that $\frac{N-N^-}{N} = o(N^{-\frac{1}{2}+\varepsilon})$. Hence, for N large enough,

$$\frac{N^-}{N}N^{-\delta} - \frac{N-N^-}{2\pi N} \geq \frac{1}{2}N^{-\delta}.$$

Then, we get

$$\begin{aligned} \mathbb{P}\left(\sum_{i=1}^T (ND_{N^-}^i - \frac{1}{2\pi T}) \geq \frac{C}{2}N^{-\frac{1}{2}+\varepsilon}\right) &\leq Tp_{N^-, \varepsilon+t, \frac{C}{8}} + T^2p_{N^-, \varepsilon, \frac{C}{8}}^2 \\ &\leq CN^{(\frac{1}{2}-\frac{3}{2}u_n)\varepsilon} + CN^{(1-2u_n)\varepsilon} \\ &\leq 2CN^{-u_{n+1}\varepsilon}. \end{aligned}$$

Besides, for all positive integer p , there exists some C' such that for all positive integer N ,

$$\begin{aligned} \mathbb{P}\left(\sum_{i < j} D_{M,M}^{i,j} \geq \frac{C}{2}N^{-\frac{1}{2}+\varepsilon}\right) &\leq C'N^{(1-2\varepsilon)p}\mathbb{E}\left[\left(\sum_{i < j} D_{M,M}^{i,j}\right)^p\right] \\ &\leq C''N^{(1-2\varepsilon)p}\log(N+1)^{3p+2}T^{p-1}M^{-2p} \\ &\leq C^{(3)}\log(N+1)^{3p+2}N^{-\frac{3}{2}\varepsilon p - \frac{\varepsilon}{2}}. \end{aligned}$$

Hence, taking p sufficiently large, we get

$$\mathbb{P}\left(\sum_{i<j} D_M^{i,j} \geq \frac{C}{2} N^{-\frac{1}{2}+\varepsilon}\right) \leq C^{(4)} N^{-u_{n+1}\varepsilon}$$

and finally, for some C ,

$$\mathbb{P}\left(ND_N - \frac{1}{2\pi} \geq CN^{-\frac{1}{2}+\varepsilon}\right) \leq CN^{-u_{n+1}\varepsilon}.$$

The other bound

$$\mathbb{P}\left(\frac{1}{2\pi} - ND_N \geq CN^{-\frac{1}{2}+\varepsilon}\right) \leq CN^{-u_{n+1}\varepsilon}$$

is proved similarly, but using the inequality

$$D_N \geq \sum_{i=1}^T D_{N^+}^i - \sum_{1 \leq i < j \leq T} D_{M,M}^{i,j}$$

instead of $D_N \leq \sum_{i=1}^T D_{N^-}^i + \sum_{1 \leq i < j \leq T} D_{M,M}^{i,j}$. This concludes the proof of the induction, and therefore the proof of the lemma. \square

Theorem 2.5.2. *For all $p \in [2, \infty)$,*

$$\mathbb{E}\left[\left|ND_N - \frac{1}{2\pi}\right|^p\right]^{\frac{1}{p}} \leq CN^{-\frac{1}{2}+o(1)}.$$

Proof. First, remark that for all $N \in \mathbb{N}^*$, $D_N \leq D_1 \leq \pi \|X\|_{\infty, [0,1]}^2$. The expression on the right admits moments of all order. Set $C_q = \mathbb{E}[D_1^q] < +\infty$, and $E_N = |ND_N - \frac{1}{2\pi}|$.

Choose $q > p$, and set $\varepsilon > 0$. Then, using a disjunction and Hölder inequality, we have

$$\mathbb{E}[E_N^p] \leq \mathbb{E}[E_N^p \mathbf{1}_{E_N \leq N^{-\frac{1}{2}+\varepsilon}}] + \mathbb{E}[E_N^q]^{\frac{p}{q}} \mathbb{P}(E_N \geq N^{-\frac{1}{2}+\varepsilon})^{\frac{q-p}{q}}.$$

The first term is less than $N^{-\frac{p}{2}+p\varepsilon}$. By Lemma 2.5.1 (applied with $k = \frac{pq}{2(q-p)}$), there exists a constant C such that for all positive integer N ,

$$\mathbb{P}(E_N \geq N^{-\frac{1}{2}+\varepsilon}) \leq CN^{-\frac{pq}{2(q-p)}}.$$

It follows that

$$\mathbb{E}[E_N^p] \leq N^{-\frac{p}{2}+p\varepsilon} + C_q^{\frac{p}{q}} C^{\frac{q-p}{q}} N^{-\frac{p}{2}} = O(N^{-\frac{p}{2}+p\varepsilon}).$$

Since ε is arbitrary small, $\mathbb{E}[E_N^p] \leq N^{-\frac{p}{2}+o(1)}$. \square

2.6 Almost sure asymptotics

We will now deduce the almost sure equivalent of the previous convergence rate. The following lemma can be thought of as a substitute for Doob's maximal inequality. The family $(ND_N)_{N \geq 1}$ does not possess the structure of a submartingale, but it has some particular structure, a kind of slow variation property which is due to the fact that the sequence D_N is decreasing. Still, we should warn the reader that the following estimate *might* follow from a clever application of the Doob's maximal inequality. The lemma is formulated with a general sequence $(D_N)_{N \geq 1}$ satisfying some assumptions. 'Our' sequence D_N of course satisfies such assumptions.

Lemma 2.6.1. *Let $(D_N)_{N \in \mathbb{N}}$ be a random sequence which is almost surely decreasing and takes non-negative values. Assume that there exists $\ell \geq 0$, $r \in (0, p)$ and $p > 1$ such that, for all N large enough,*

$$\mathbb{E}[|ND_N - \ell|^p] \leq N^{-r}.$$

Then, for all $q < \frac{p-1}{p}r$,

$$\mathbb{E}\left[\sup_{N \geq N_0} N^q |ND_N - \ell|^p\right] \xrightarrow{N_0 \rightarrow \infty} 0.$$

Proof. Let $\gamma \in \left(\frac{1}{r-q}, \frac{p-1}{q}\right)$. This set is non empty precisely when $q < \frac{p-1}{p}r$. Because $\frac{p-1}{q} > \frac{p}{r} > 1$, we can assume that $\gamma > 1$. We then define $\mathbb{N}^\gamma = \{\lfloor K^\gamma \rfloor : K \in \mathbb{N}^*\}$. The main idea of the proof is to replace \mathbb{N} with \mathbb{N}^γ in the supremum. Since this set is 'sparser', we can then bound the supremum with a sum, and still get something finite. Of course, we then have to replace back \mathbb{N}^γ with \mathbb{N} . This is done by showing that ND_N varies slowly.

For $M \in \mathbb{N}^\gamma$, let $s(M)$ be the successor of M in \mathbb{N}^γ (that is, the smallest element of \mathbb{N}^γ which is strictly larger than M). Then, for $N \in \mathbb{N}$, let N_- and N_+ be the two unique elements of \mathbb{N}^γ such that $N_- \leq N < N_+ = s(N_-)$.

Then, $N_+^{\frac{q}{p}}(ND_N - \ell)$ is less than $N_+^{\frac{q}{p}}(N_+D_{N_-} - \ell)$. We decompose this quantity into

$$N_-^{\frac{q}{p}}(N_-D_{N_-} - \ell) + (N_+^{\frac{q}{p}} - N_-^{\frac{q}{p}})(N_-D_{N_-} - \ell) + N_+^{\frac{q}{p}}(N_+ - N_-)D_{N_-}.$$

For $N_0 \in \mathbb{N}^\gamma$, we obtain

$$\begin{aligned} \mathbb{E}\left[\max_{\substack{N \in \mathbb{N} \\ N \geq N_0}} \mathbb{1}_{ND_N - \ell \geq 0} N^q (ND_N - \ell)^p\right] &\leq C_p \left(\mathbb{E}\left[\max_{\substack{M \in \mathbb{N}^\gamma \\ M \geq N_0}} M^q (MD_M - \ell)^p\right] \right. \\ &\quad \left. + \mathbb{E}\left[\max_{\substack{M \in \mathbb{N}^\gamma \\ M \geq N_0}} (s(M))^{\frac{q}{p}} - M^{\frac{q}{p}}\right]^p (MD_M - \ell)^p + \mathbb{E}\left[\max_{\substack{M \in \mathbb{N}^\gamma \\ M \geq N_0}} (s(M))^q (s(M) - M)^p D_M^p\right] \right). \end{aligned}$$

The first term on the right-hand side is the one that we wanted in the first place: the same thing as our initial maximum, but with \mathbb{N}^γ instead of \mathbb{N} .

To bound the two other terms, let us remark that for all $\alpha \neq 0$, $s(M) \sim M$ and $s(M)^\alpha - M^\alpha \sim$

$C_{\alpha,\gamma}M^{\alpha-\frac{1}{\gamma}}$ for some constant $C_{\alpha,\gamma}$. The previous expression can then be reduced to

$$\begin{aligned} \mathbb{E}\left[\max_{\substack{N \in \mathbb{N} \\ N \geq N_0}} \mathbb{1}_{ND_N \geq \ell} N^q (ND_N - \ell)^p\right] &\leq C' \left(\mathbb{E}\left[\max_{\substack{M \in \mathbb{N}^\gamma \\ M \geq N_0}} M^q (MD_M - \ell)^p\right] \right. \\ &\quad \left. + \mathbb{E}\left[\max_{\substack{M \in \mathbb{N}^\gamma \\ M \geq N_0}} (M^{q-\frac{p}{\gamma}} (MD_M - \ell)^p)\right] + \mathbb{E}\left[\max_{\substack{M \in \mathbb{N}^\gamma \\ M \geq N_0}} M^{q+p-\frac{p}{\gamma}} D_M^p\right] \right) \\ &\leq C'' \left(\mathbb{E}\left[\max_{\substack{M \in \mathbb{N}^\gamma \\ M \geq N_0}} M^q (MD_M - \ell)^p\right] + \mathbb{E}\left[\max_{\substack{M \in \mathbb{N}^\gamma \\ M \geq N_0}} M^{q+p-\frac{p}{\gamma}} D_M^p\right] \right). \end{aligned} \quad (2.23)$$

Let us denote $K_0 = \lfloor N_0^\gamma \rfloor$. Then,

$$\begin{aligned} \mathbb{E}\left[\max_{\substack{N \in \mathbb{N}^\gamma \\ N \geq N_0}} N^q |ND_N - \ell|^p\right] &\leq \sum_{\substack{N \in \mathbb{N}^\gamma \\ N \geq N_0}} \mathbb{E}[N^q |ND_N - \ell|^p] \leq \sum_{N \in \mathbb{N}^\gamma, N \geq N_0} N^{q-r} \leq \sum_{\substack{K \in \mathbb{N} \\ K \geq K_0}} K^{\gamma(q-r)} \\ &\leq (N_0^\gamma)^{\gamma(q-r)-1} (1 + o(1)) \quad (\text{since } \gamma(q-r) < -1) \\ &\leq N_0^{(q-r)-\frac{1}{\gamma}} (1 + o(1)). \end{aligned} \quad (2.24)$$

Replacing \mathbb{N} with \mathbb{N}^γ is necessary for the inequality from the second to the third line: the additional power γ makes the sum converge.

To control the last error term, we also need the following estimation:

$$\begin{aligned} \mathbb{E}\left[\max_{\substack{N \in \mathbb{N}^\gamma \\ M \geq N_0}} N^{q+p-\frac{p}{\gamma}} D_N^p\right] &\leq \sum_{\substack{N \in \mathbb{N}^\gamma \\ N \geq N_0}} N^{q+p-\frac{p}{\gamma}} \mathbb{E}[D_N^p] \leq C \sum_{\substack{N \in \mathbb{N}^\gamma \\ N \geq N_0}} N^{q-\frac{p}{\gamma}} \leq C \sum_{\substack{K \in \mathbb{N} \\ K \geq K_0}} K^{\gamma q-p} \\ &\leq C' K_0^{\gamma q-p+1}, \end{aligned} \quad (2.25)$$

since $\gamma q - p < -1$. Putting (2.23), (2.24) and (2.25) together, we obtain

$$\mathbb{E}\left[\max_{\substack{N \in \mathbb{N} \\ N \geq N_0}} \mathbb{1}_{ND_N - \ell \geq 0} N^q (ND_N - \ell)^p\right] \xrightarrow{N_0 \rightarrow +\infty} 0.$$

We show similarly that

$$\mathbb{E}\left[\max_{\substack{N \in \mathbb{N} \\ N \geq N_0}} \mathbb{1}_{ND_N - \ell \leq 0} N^q (ND_N - \ell)^p\right] \xrightarrow{N_0 \rightarrow +\infty} 0,$$

which concludes the proof of the lemma. \square

We immediately deduce the following, where the sequence D_N is again the one given by the windings of the Brownian motion. ³

³At this stage, we hope that the reader know what the value D_N is.

Corollary 2.6.2. *Almost surely,*

$$|ND_N - \frac{1}{2\pi}| \leq N^{-\frac{1}{2}+o(1)},$$

Proof. From Theorem 2.5.2, we know that the hypothesis of Lemma 2.6.1 are satisfied by the sequence D_N , for all $p \in [1, +\infty)$ and for all $r \in [0, \frac{p}{2})$.

It follows that for all $q \in [0, \frac{p-1}{2})$,

$$\mathbb{E} \left[\max_{\substack{N \in \mathbb{N}^* \\ N \geq N_0}} N^q |ND_N - \frac{1}{2\pi}|^p \right] \xrightarrow{N_0 \rightarrow \infty} 0.$$

Markov inequality ensures

$$\mathbb{P} \left[\max_{\substack{N \in \mathbb{N}^* \\ N \geq N_0}} N^q |ND_N - \frac{1}{2\pi}|^p \geq 1 \right] \xrightarrow{N_0 \rightarrow \infty} 0,$$

so that for all $q' < q$, the quantity $N^{q'} |ND_N - \frac{1}{2\pi}|^p$ converges almost surely to 0. We conclude by taking p arbitrary large, q arbitrary close to $\frac{p-1}{2}$, and q' arbitrary close to q . \square

2.7 About the value of the gap

Let us comment about the exponent $\delta = \frac{1}{2}$ in the bound $|ND_N - \frac{1}{2\pi}| \leq N^{-\frac{1}{2}+o(1)}$. The precise value is not very important when trying to give a Green formula. Nonetheless, it becomes very important in the last chapters, in which we will define the Lévy area for a very wild area measure. The area measure will depend on a parameter γ (the *intermittency* parameter), and we will be able to define the Lévy area only for some range of γ . The larger δ , the wider is the range on γ .

It was a recurrent problem for us to obtain an exponent δ as large as possible. Actually, the proofs given here were reworked many times before we could obtain the value $\frac{1}{2}$. The first proof wasn't even giving an explicit value. Then, the first explicit value was very low, and we introduced the bootstrap in the beginning to improve this bound (though we use it finally for different purposes in the next chapters). Even the L^p bounds were first obtained only to improve the value of the almost sure gap δ .

Though it still seems that we are losing a lot of precision at many steps during the proof, we think the final value $\frac{1}{2}$ is optimal, in the following sense.

Conjecture 2.7.1. *There exists no deterministic function f and $\varepsilon > 0$ such that almost surely, there exists C such that for all N ,*

$$|D_N - f(N)| \leq CN^{-\frac{3}{2}-\varepsilon}.$$

We are proposing here a *very informal* justification for this conjecture. We should warn the reader that our argument might be biased by our feeling that something happens *at* the value $\frac{1}{2}$, and our eagerness to know what exactly.

We first remark that it suffices to show that there exists a process X' whose law is absolutely continuous with respect to the one of the Brownian motion X , and such that the large winding areas $D_N^{X'}$ and D_N^X differ by at least $N^{-\frac{3}{2}-\varepsilon}$. That is,

$$|D_N^{X'} - D_N^X| \geq CN^{-\frac{3}{2}-\varepsilon}.$$

We then consider a planar fractional Brownian motion X^H with Hurst parameter $H \in (0, 1)$. This is a process which is α -Hölder continuous for $\alpha < H$ but not for $\alpha = H$. It is known [10] that the process $X' = X + X^H$ is absolutely continuous with respect to X if and only if $H > \frac{3}{4}$.

The rough idea that we now develop (once again, very informally) is that $D_N^{X'} - D_N^X$ is of order at least $N^{-2H-\varepsilon'}$, for all $\varepsilon' > 0$. Since we can go for H arbitrary close to $\frac{3}{4}$ and keep absolute continuity, we end up with an exponent $N^{-\frac{3}{2}-\varepsilon}$.

From the relations between Hölder continuity and integrability of the winding function, we know that, for $H > \frac{1}{2}$, θ^{X^H} lies in $L^{2H-\varepsilon}(\mathbb{R}^2)$, and we can expect that it almost surely does not lie in $L^{2H}(\mathbb{R}^2)$.⁴

In the following, we will more precisely assume the following

Conjecture 2.7.2. *For $H \geq \frac{1}{2}$, there exists constant C_H such that for all $z \in \mathbb{R}^2$,*

$$\mathbb{P}(\theta^{X^H}(z) = N) \sim C_H \int_0^1 p_t^H(0, z) dt N^{-1-2H},$$

where p^H is the fractional heat kernel.

This is true in particular in the case $H = \frac{1}{2}$ (see [47], page 121). Since we are being informal, we do not question which kind of uniformity in z would also be necessary for the following reasoning to be rigorous. We freely integrate the relation as the fancy takes us.

For $H > \frac{1}{2}$, the process X' looks very much like X^H at a macroscopic scale, but it looks very much like X (up to translation) at a microscopic scale. Because of this difference of scale, we expect that for a point z very close to X'_t ,

$$\theta^{X'}(z) \simeq \theta^X(z - X'_t) + \theta^{X^H}(z),$$

so that

$$A_j^{X'} \simeq \sum_{k \in \mathbb{Z}} |\mathcal{A}_{j-k}^X \cap \mathcal{A}_k^{X^H}|.$$

One again, such a relation should be quantified properly in order to turn our scheme of proof into something formal.

Then, we get

$$\begin{aligned} \mathbb{E}[D_N^{X'}] &\simeq \sum_{j=N}^{+\infty} \sum_{k \in \mathbb{Z}} \mathbb{E}[|\mathcal{A}_{j-k}^X \cap \mathcal{A}_k^{X^H}|] \\ &\geq \sum_{j=N}^{+\infty} \sum_{|k| \leq N^\delta} \mathbb{E}[|\mathcal{A}_{j-k}^X \cap \mathcal{A}_k^{X^H}|] \\ &= \sum_{|k| \leq N^\delta} \mathbb{E}[|\mathcal{D}_{N-k}^X \cap \mathcal{A}_k^{X^H}|]. \end{aligned} \tag{2.26}$$

⁴Surprising things might possibly happen here, though. For example, we think it is not hard to show, using the results of [7], that stable processes other than the Brownian motion admit a winding function in L^2 , which is much more than what is expected from their p -variation regularity. We do think no such surprise arises for the fractional Brownian motion. It might be nonetheless that $N^{1+2H} A_N^{X^H}$ converges in distribution, but not toward a constant.

As $|j|$ and $|k|$ both go to infinity, we have

$$\begin{aligned} \mathbb{E}[|\mathcal{A}_j^X \cap \mathcal{A}_k^{X^H}|] &= \int_{\mathbb{R}^2} \mathbb{P}(\theta^X(z) = j) \mathbb{P}(\theta^{X^H}(z) = k) dz \\ &\sim \left(\int_{\mathbb{R}^2} \int_0^1 p_t(0, z) dt \int_0^1 p_t^H(0, z) dt dz \right) |j|^{-2} |k|^{-2H-1}. \end{aligned}$$

We deduce that for $\delta < 1$ sufficiently close to 1,

$$\begin{aligned} \mathbb{E}[|\mathcal{D}_N^X|] &= \sum_{j \geq N} \sum_{k \in \mathbb{Z}} \mathbb{E}[|\mathcal{A}_j^X \cap \mathcal{A}_k^{X^H}|] \\ &= \sum_{j \geq N} \sum_{|k| \leq N^\delta} \mathbb{E}[|\mathcal{A}_j^X \cap \mathcal{A}_k^{X^H}|] + O(N^{-1-2H\delta}) \\ &= \sum_{|k| \leq N^\delta} \mathbb{E}[|\mathcal{D}_N^X \cap \mathcal{A}_k^{X^H}|] + O(N^{-1-2H\delta}). \end{aligned} \tag{2.27}$$

Combining Equations (2.26) and (2.27) gives

$$\begin{aligned} \mathbb{E}[D_N^{X'} - D_N^X] &\geq \sum_{|k| \leq N^\delta} \mathbb{E}[|\mathcal{D}_{N-k}^X \cap \mathcal{A}_k^{X^H}| - |\mathcal{D}_N^X \cap \mathcal{A}_k^{X^H}|] + O(N^{-1-2H\delta}) \\ &= \sum_{k=1}^{N^\delta} \mathbb{E}[|(\mathcal{D}_{N-k}^X \setminus \mathcal{D}_N^X) \cap \mathcal{A}_k^{X^H}| - |(\mathcal{D}_N^X \setminus \mathcal{D}_{N+k}^X) \cap \mathcal{A}_k^{X^H}|] + O(N^{-1-2H\delta}) \\ &= \left(\int_{\mathbb{R}^2} \int_0^1 p_t(0, z) dt \int_0^1 p_t^H(0, z) dt dz + o(1) \right) \\ &\quad \sum_{k=1}^{N^\delta} \mathbb{E}[|(\mathcal{D}_{N-k}^X \setminus \mathcal{D}_N^X)| - |(\mathcal{D}_N^X \setminus \mathcal{D}_{N+k}^X)|] \mathbb{E}[|\mathcal{A}_k^{X^H}|] + O(N^{-1-2H\delta}) \\ &= C(1 + o(1)) \sum_{k=1}^{N^\delta} \mathbb{E}[D_{N-k}^X - 2D_N^X + D_{N+k}^X] \mathbb{E}[|\mathcal{A}_k^{X^H}|] + O(N^{-1-2H\delta}) \\ &\geq C' \sum_{k=N^{\frac{1}{4}}}^{N^\delta} \mathbb{E}[D_{N-k}^X - 2D_N^X + D_{N+k}^X] \mathbb{E}[|\mathcal{A}_k^{X^H}|] + O(N^{-1-2H\delta}). \end{aligned}$$

A simple computation (using the second order asymptotic on D_N) gives

$$\mathbb{E}[D_{N-k}^X - 2D_N^X + D_{N+k}^X] = \frac{1}{\pi} \frac{k^2}{N^2} (1 + o(1)) + O(N^{-\frac{3}{2} + o(1)}) = \frac{1}{\pi} \frac{k^2}{N^2} (1 + o(1)),$$

with the last equality holding for $k \geq N^{\frac{1}{4}}$. We finally get

$$\mathbb{E}[D_N^{X'} - D_N^X] \geq C \sum_{k=N^{\frac{1}{4}}}^{N^\delta} k^2 N^{-2} k^{-1-2H} + O(N^{-1-2H\delta}) \sim C' N^{-2+\delta(2-2H)}.$$

As δ is arbitrarily close to 1, the last exponent is arbitrarily close to $-2H$, which is exactly what we expected.

Remark that, if this reasoning can be made rigorous, it should allow us to partially rediscover the result of [10]. That is, it should also be possible to deduce that for $H \in (\frac{1}{2}, \frac{3}{4})$, $\mathcal{D}_N^{X+X^H} - \frac{1}{2\pi N}$ is asymptotically larger than $N^{-\frac{3}{2}+\varepsilon}$, hence that $X + X^H$ cannot be absolutely continuous with respect to the Brownian motion.

For such a process X' , we expect that $D_N^{X'} - D_{-N}^{X'}$ is still of order $N^{-\frac{3}{2}+o(1)}$, even for $H \in (\frac{1}{2}, \frac{3}{4}]$: the ‘drift’ tends to increase the value of D_N , but to increase as well the value of D_{-N} . The two increasings should, almost surely, be equal up to a small correction term.

We think it is plausible that $D_N^X - D_{-N}^X$ is actually of smaller order than $D_N^X - \frac{1}{2\pi N}$.

Chapter 3

Distribution of the large winding set

We prove that the random measure on the plane with density $2\pi N \mathbb{1}_{\mathcal{D}_N}$ with respect to the Lebesgue measure converges almost surely weakly, as N tends to infinity, towards the occupation measure of the Brownian motion.

3.1 Introduction

Let us recall that \mathcal{D}_N denotes the set of points with winding equal to or greater than N . For all $N \geq 1$, we denote by μ_N the random measure on the plane with density $2\pi N \mathbb{1}_{\mathcal{D}_N}$ with respect to the Lebesgue measure:

$$d\mu_N(z) = 2\pi N \mathbb{1}_{\mathcal{D}_N}(z) dz.$$

Let ν be the occupation measure of X , defined as the push-forward of the Lebesgue measure on $[0, 1]$ by X . In other words, ν is the random Borel probability measure on the plane characterised by the fact that for every continuous test function $f : \mathbb{R}^2 \rightarrow \mathbb{R}$,

$$\int_{\mathbb{R}^2} f d\nu = \int_0^1 f(X_t) dt.$$

The main result of this chapter is the following.

Theorem 3.1.1. *Almost surely, $\mu_N \xrightarrow[N \rightarrow \infty]{} \nu$.*

To be clear, we mean that almost surely, for all bounded continuous function $f : \mathbb{R}^2 \rightarrow \mathbb{R}$, the following convergence holds:

$$\lim_{N \rightarrow \infty} 2\pi N \int_{\mathbb{R}^2} f(z) \mathbb{1}_{[N, +\infty)}(\theta(z)) dz = \int_0^1 f(X_u) du.$$

The assumption that the test function is bounded is not essential, because almost surely, the supports of the measures μ_N , $N \geq 1$ and ν are contained in the convex hull of the range of X , which is compact.

In the course of the proof, we will obtain an estimation of the rate of convergence in terms of the modulus of continuity of the test function f (see Lemma 3.2.1).

Whilst the previous chapter is partly motivated by the convergence proved by W. Werner in [47], Theorem 3.1.1 is motivated by his article [48], where he proves a Green's theorem. His results suggested to us that when N is large, the set \mathcal{D}_N , which is located near the trajectory X , has a very balanced distribution along this trajectory. We consider Theorem 3.1.1 as a rigorous formulation of this idea.

We first recall a few results and notations from the previous chapter.

The Brownian motion $X : [0, 1] \rightarrow \mathbb{R}^2$ is defined under a probability that we denote by \mathbb{P} .

Let T be a positive integer. The integer-valued function θ^i is the winding function of X^i , defined almost everywhere on the plane. For two positive integers N, M ,

$$\mathcal{D}_N^i = \{z \in \mathbb{R}^2 : \theta^i(z) \geq N\} \quad \text{and} \quad \mathcal{D}_{N,M}^{i,j} = \{z \in \mathbb{R}^2 : |\theta^i(z)| \geq N, |\theta^j(z)| \geq M\},$$

with absolute values intended in the second definition. Here we will only need the set $\mathcal{D}_{M,M}^{i,j}$ so we omit the second index: $\mathcal{D}_M^{i,j} = \mathcal{D}_{M,M}^{i,j}$. We recall that the calligraphic letter \mathcal{D} in these notations is replaced with the straight letter D when we are considering the Lebesgue measure of the set.

We will use the following mild reformulation of Lemmas 2.18, 2.5.1, and 2.2.6.

Lemma 3.1.2. *Let μ be a Borel measure on \mathbb{R}^2 , absolutely continuous with respect to the Lebesgue measure. For all positive integers N, T, M such that $T(M+1) < N$,*

$$\sum_{i=1}^T \mu(\mathcal{D}_{N+T+M(T-1)}^i) - \sum_{1 \leq i < j \leq T} \mu(\mathcal{D}_M^{i,j}) \leq \mu(\mathcal{D}_N) \leq \sum_{i=1}^T \mu(\mathcal{D}_{N-T-M(T-1)}^i) + \sum_{1 \leq i < j \leq T} \mu(\mathcal{D}_M^{i,j}).$$

Lemma 3.1.3. *For all $\delta < \frac{1}{2}$ and $p > 0$, there exists $C > 0$ such that for all $N \geq 1$ and all $R > 0$,*

$$\mathbb{P}\left(N^\delta |2\pi N D_N - 1| \geq R\right) \leq CR^{-p}.$$

Lemma 3.1.4. *For all $\varepsilon > 0$, there exists $C > 0$ such that for all positive integers T, M ,*

$$\mathbb{E}\left[\left(\sum_{1 \leq i < j \leq T} D_M^{i,j}\right)^2\right] \leq CM^{-4+\varepsilon}T^{1+\varepsilon}.$$

3.2 Proof of Theorem 3.1.1

Let $f : \mathbb{R}^2 \rightarrow \mathbb{R}$ be a bounded continuous function. Let ω_f be the modulus of continuity of f : for all $t \geq 0$,

$$\omega_f(t) = \sup\{|f(z) - f(w)| : z, w \in \mathbb{R}^2, \|z - w\| \leq t\} \in [0, +\infty].$$

For all Borel subset E of \mathbb{R}^2 , we also set $f(E) = \int_E f(z) dz$.

For $\alpha \in (0, \frac{1}{2})$, let $\|X\|_{C^\alpha}$ denote the α -Hölder norm of the Brownian motion:

$$\|X\|_{C^\alpha} = \sup_{0 \leq s < t \leq 1} \frac{\|X_t - X_s\|}{|t - s|^\alpha}.$$

We have the following quantitative estimation.

Lemma 3.2.1. *For all $t \in (0, \frac{2}{5})$ and $\alpha \in (0, \frac{1}{2})$, there exists $\eta > 0$ such that \mathbb{P} -almost surely, there exists a constant C such that for all bounded continuous function $f : \mathbb{R}^2 \rightarrow \mathbb{R}$ and all $N \geq 1$,*

$$\left| 2\pi N f(\mathcal{D}_N) - \int_0^1 f(X_u) du \right| \leq C(\omega_f(2\|X\|_{\mathcal{C}^\alpha} N^{-\alpha t}) + \|f\|_\infty N^{-\eta}).$$

Let us explain why this lemma directly implies Theorem 3.1.1.

Proof of Theorem 3.1.1 assuming Lemma 3.2.1. Thanks to the Portmanteau theorem, it suffices to show that \mathbb{P} -almost surely, for any bounded Lipschitz continuous function f ,

$$\left| 2\pi N f(\mathcal{D}_N) - \int_0^1 f(X_u) du \right| \xrightarrow{N \rightarrow +\infty} 0.$$

For such a function f , one has $\omega_f(t) \leq \|f\|_{\text{Lip}} t$ and the result follows from Lemma 3.2.1 applied for instance to $t = \frac{1}{5}$ and $\alpha = \frac{1}{4}$. \square

In order to prove Lemma 3.2.1, we introduce the following subset of \mathbb{N} , which depends on a positive real parameter $\gamma > 1$:

$$\mathbb{N}^\gamma = \{\lfloor K^\gamma \rfloor : K \in \mathbb{N} \setminus \{0\}\}.$$

Let us fix two positive real parameters t and m with $m + t < 1$ and set, for all $N \geq 1$, $T = \lfloor N^t \rfloor$ and $M = \lfloor N^m \rfloor$. We advise the reader to think of m as being larger than $\frac{1}{2}$, and of t as a small number. Precise conditions can be found in the statement of Lemma 3.2.3.

We also set $N' = \max\{n \in \mathbb{N}^\gamma : n \leq N - T - M(T - 1)\}$, which is well defined when N is large enough. The difference between N and N' is $O(N^{1-1/\gamma} + N^{m+t})$.

We also define the following events, which depend on t and m , and also on other positive real parameters s, ζ, δ :

$$\begin{aligned} E_N &= \{\forall i \in \{1, \dots, T\}, N'^\delta |2\pi N' D_{N'}^i - \frac{1}{T}| \leq T^{-\frac{1}{2} + \frac{s}{t}}\}, \\ F_N &= \left\{ \sum_{1 \leq i < j \leq T} D_M^{i,j} \leq N^{-1-\zeta} \right\}, \\ G_N &= \{\forall i \in \{1, \dots, T\}, 2\pi N D_{N'}^i \leq \frac{2}{T}\}. \end{aligned}$$

The proof goes in three steps. In the first (Lemma 3.2.2), we show that with an appropriate choice of γ , almost surely, the events E_N, F_N and G_N are realised for all $N \in \mathbb{N}^\gamma$ large enough. In a second step (Lemma 3.2.3), we show that on this almost sure event, for every bounded continuous function, and for all $N \in \mathbb{N}^\gamma$, the conclusion of Lemma 3.2.1 holds. In the third step, we show that the conclusion holds not only for $N \in \mathbb{N}^\gamma$, but for all $N \in \mathbb{N}$.

Let us collect in one place the assumptions that we make on the parameters that we introduced. These assumptions are organised in such a way that if enforced in the natural reading order, they are always satisfiable.

$$0 < \alpha < \frac{1}{2}, \quad 0 < t < \frac{2}{5}, \quad \frac{1}{2} + \frac{t}{4} < m < 1 - t, \quad 0 < \zeta < 2m - 1 - \frac{t}{2}, \quad \gamma > \max\left(\frac{1}{2s}, \frac{1}{4m-t-2-2\zeta}\right). \\ 0 < s < \frac{1}{2} - \frac{t}{2}, \quad \frac{t}{2} + s < \delta < \frac{1}{2}, \tag{A}$$

From now on, we always assume that these assumptions are satisfied.

Lemma 3.2.2. *The event $\bigcup_{N_0 \geq 1} \bigcap_{\substack{N \in \mathbb{N}^\gamma \\ N \geq N_0}} (E_N \cap F_N \cap G_N)$ has probability 1.*

Proof. The scaling properties of the Brownian motion imply that $D_{N'}^i$ is equal in distribution to $T^{-1}D_{N'}$. Thus,

$$1 - \mathbb{P}(E_N) \leq T \mathbb{P}(N'^\delta |2\pi N' D_{N'} - 1| \geq T^{\frac{1}{2} + \frac{s}{t}}).$$

Using Lemma 3.1.3 with $p = 2$ gives

$$1 - \mathbb{P}(E_N) \leq CT^{-\frac{2s}{t}},$$

and for N large enough, this quantity is smaller than $2CN^{-2s}$. In particular,

$$\sum_{N \in \mathbb{N}^\gamma} (1 - \mathbb{P}(E_N)) \leq 2C \sum_{K=1}^{+\infty} K^{-2s\gamma}.$$

Besides, by Markov inequality,

$$1 - \mathbb{P}(F_N) \leq N^{2+2\zeta} \mathbb{E} \left[\left(\sum_{1 \leq i < j \leq T} D_M^{i,j} \right)^2 \right].$$

By Lemma 3.1.4, for any $\varepsilon > 0$, there exists C such that for all N ,

$$1 - \mathbb{P}(F_N) \leq CN^{-4m+t+2+2\zeta+\varepsilon}.$$

In particular,

$$\sum_{N \in \mathbb{N}^\gamma} (1 - \mathbb{P}(F_N)) \leq C \sum_{K=1}^{+\infty} K^{\gamma(-4m+t+2+2\zeta+\varepsilon)}.$$

We assumed that $\gamma > \frac{1}{4m-t-2-2\zeta}$, so that there exists $\varepsilon > 0$ such that $\gamma > \frac{1}{4m-t-2-2\zeta-\varepsilon}$. Since we also assumed that $\gamma > \frac{1}{2s}$, the series

$$\sum_{K=1}^{+\infty} K^{-\gamma(4m-t-2-2\zeta-\varepsilon)} \quad \text{and} \quad \sum_{K=1}^{+\infty} K^{-\gamma(2s)}$$

are both convergent.

Using Borel–Cantelli lemma, we conclude the proof, but for the presence of G_N . However, using the fact that N' is not larger than N and equivalent to N as N tends to infinity, and the inequality $T \leq N^t$, one verifies that if $t + 2s < 2\delta$, then for N large enough, the inclusion $E_N \subset G_N$ holds. Hence, the proof is complete. \square

We now turn to the second step of the proof.

Lemma 3.2.3. *Almost surely, there exists a constant C such that for all $N \in \mathbb{N}^\gamma$ and all bounded continuous function $f : \mathbb{R}^2 \rightarrow \mathbb{R}$,*

$$\left| 2\pi N f(\mathcal{D}_N) - \int_0^1 f(X_u) du \right| \leq C \left(\omega_f(\|X\|_{C^\alpha} T^{-\alpha}) + \|f\|_\infty (N^{-1+m+t} + N^{-\frac{1}{\gamma}+1} + N^{-\delta+\frac{t}{2}+s} + N^{-\zeta}) \right).$$

Proof. We first assume that f is non-negative. Replacing C if necessary by a larger constant, it suffices to show the inequality for $N \geq N_0$, for a possibly random N_0 which does not depend on f . Using Lemma 3.2.2, we can thus assume that the event $E_N \cap F_N \cap G_N$ holds.

Using Lemma 3.1.2, the assumption that f is non-negative and the fact that the sequence $(\mathcal{D}_N^i)_{N \geq 1}$ is non-increasing, we have

$$\begin{aligned} Nf(\mathcal{D}_N) &\leq \sum_{i=1}^T Nf(\mathcal{D}_{N-T-M(T-1)}^i) + \sum_{1 \leq i < j \leq T} Nf(\mathcal{D}_M^{i,j}) \\ &\leq \sum_{i=1}^T Nf(\mathcal{D}_{N'}^i) + \sum_{1 \leq i < j \leq T} Nf(\mathcal{D}_M^{i,j}). \end{aligned} \quad (3.1)$$

Besides, $\mathcal{D}_{N'}^i$ is contained in the convex hull of the trajectory of X between the times $\frac{i}{T}$ and $\frac{i+1}{T}$, hence in the ball of center $X_{\frac{i}{T}}$ and radius $\|X\|_{\mathcal{C}^\alpha} T^{-\alpha}$, so that

$$Nf(\mathcal{D}_{N'}^i) \leq ND_{N'}^i f(X_{\frac{i}{T}}) + ND_{N'}^i \omega_f(\|X\|_{\mathcal{C}^\alpha} T^{-\alpha}).$$

We replace in (3.1) and force the apparition of a Riemann sum by decomposing $ND_{N'}^i$ into

$$\frac{1}{2\pi T} + \frac{N - N'}{2\pi TN'} + N \left(D_{N'} - \frac{1}{2\pi TN'} \right).$$

We obtain

$$\begin{aligned} \sum_{i=1}^T Nf(\mathcal{D}_{N'}^i) &\leq \sum_{i=1}^T \frac{1}{2\pi T} f(X_{\frac{i}{T}}) + \sum_{i=1}^T \frac{N-N'}{2\pi TN'} f(X_{\frac{i}{T}}) + N \sum_{i=1}^T \left(D_{N'}^i - \frac{1}{2\pi TN'} \right) f(X_{\frac{i}{T}}) \\ &\quad + N \sum_{i=1}^T D_{N'}^i \omega_f(\|X\|_{\mathcal{C}^\alpha} T^{-\alpha}). \end{aligned}$$

Comparing the Riemann sum with the integral and f to its upper bound, we turn this inequality into

$$\begin{aligned} 2\pi \sum_{i=1}^T Nf(\mathcal{D}_{N'}^i) &\leq \int_0^1 f(X_u) du + \omega_f(\|X\|_{\mathcal{C}^\alpha} T^{-\alpha}) + \|f\|_\infty \frac{N-N'}{N'} + \|f\|_\infty N \sum_{i=1}^T \left(2\pi D_{N'}^i - \frac{1}{TN'} \right) \\ &\quad + 2\pi \omega_f(\|X\|_{\mathcal{C}^\alpha} T^{-\alpha}) N \sum_{i=1}^T D_{N'}^i. \end{aligned}$$

Our next goal is to bound the last three terms of the right-hand side. Let us discuss the first, then the third and finally the second.

For the first term, it follows from the definition of N' and by elementary arguments that for N large enough, indeed larger than a certain N_1 that does not depend on f ,

$$\frac{N - N'}{N'} < 2(N^{m+t-1} + \gamma N^{-\frac{1}{\gamma}+1}).$$

For the third term, since the event G_N holds, we have

$$\sum_{i=1}^T D_{N'}^i \leq T \max_{i \in \{1, \dots, T\}} D_{N'}^i \leq \frac{1}{\pi N}.$$

Finally, since the event E_N holds, and for N large enough,

$$\sum_{i=1}^T \left(2\pi D_{N'}^i - \frac{1}{TN'} \right) \leq N^{t-1-\delta} T^{\frac{1}{2} + \frac{s}{t}} \leq 2N^{-1-\delta+\frac{t}{2}+s}.$$

Here the second inequality holds for N larger than a certain N_2 which does not depend on f .

We end up with

$$2\pi \sum_{i=1}^T N f(\mathcal{D}_{N'}^i) - \int_0^1 f(X_u) du \leq 3\omega_f(\|X\|_{C^\alpha} T^{-\alpha}) + 2\|f\|_\infty (N^{m+t-1} + \gamma N^{-\frac{1}{\gamma}+1} + N^{-\delta+\frac{t}{2}+s}). \quad (3.2)$$

We now turn to the second term of the right-hand side of (3.1). Since F_N holds,

$$N \sum_{1 \leq i < j \leq T} f(\mathcal{D}_M^{i,j}) \leq N\|f\|_\infty \sum_{1 \leq i < j \leq T} D_M^{i,j} \leq \|f\|_\infty N^{-\zeta}. \quad (3.3)$$

Using (3.1), (3.2) and (3.3), we get that almost surely, for $N \geq \max(N_0, N_1, N_2)$,

$$2\pi N f(\mathcal{D}_N) - \int_0^1 f(X_u) du \leq 3\omega_f(\|X\|_{C^\alpha} T^{-\alpha}) + 2\|f\|_\infty (N^{m+t-1} + \gamma N^{-\frac{1}{\gamma}+1} + N^{-\delta+\frac{t}{2}+s} + N^{-\zeta}). \quad (3.4)$$

To obtain this upper bound, we used the second inequality of Lemma 3.1.2, and the definition of N' which was suggested by the term $N - T - M(T - 1)$ that appears in it. A repetition of the exact same arguments, with the difference that N' is now defined as the largest element of \mathbb{N}^γ smaller than $N + T + M(T - 1)$, and using the first inequality of Lemma 3.1.2 instead of the second, yields the corresponding lower bound, saying that the left-hand side of (3.4) is larger than the opposite of the right-hand side of (3.4).

This concludes the proof when f is non-negative. To remove this assumption, it suffices to decompose f into the sum of its positive and negative parts. \square

We now extend Lemma 3.2.3 from $N \in \mathbb{N}^\gamma$ to $N \in \mathbb{N}^*$, in order to obtain Lemma 3.2.1.

Proof of Lemma 3.2.1. The reals t and α being given, choose positive real numbers $s, \zeta, m, \delta, \gamma$ which satisfy the assumptions (A). Set $\eta = \min(1 - m - t, \frac{1}{\gamma} - 1, \delta - \frac{t}{2} - s, \zeta) > 0$.

Let us first assume f is non-negative. Set $\tilde{N} = \max\{n \in \mathbb{N}^\gamma : n \leq N\}$, the largest integer smaller than N in \mathbb{N}^γ .

Since the sequence $(f(\mathcal{D}_N))_{N \geq 1}$ is non-increasing, we have

$$\begin{aligned} 2\pi N f(\mathcal{D}_N) - \int_0^1 f(X_u) du &\leq 2\pi N f(\mathcal{D}_{\tilde{N}}) - \int_0^1 f(X_u) du \\ &= \frac{N}{\tilde{N}} \left(2\pi \tilde{N} f(\mathcal{D}_{\tilde{N}}) - \int_0^1 f(X_u) du \right) + \left(\frac{N}{\tilde{N}} - 1 \right) \int_0^1 f(X_u) du. \end{aligned}$$

The first term is taken care of by Lemma 3.2.3 and the fact that $N \leq 2\tilde{N}$ for N large enough. The second term is bounded above, for N sufficiently large, by $2\gamma\|f\|_\infty N^{-\frac{1}{\gamma}+1}$. Altogether, we find the upper bound

$$2\pi N f(\mathcal{D}_N) - \int_0^1 f(X_u) \, du \leq C(\omega_f(\|X\|_{C^\alpha} T^{-\alpha}) + \|f\|_\infty N^{-\eta})$$

for some constant C . The corresponding lower bound is obtained by the same argument with \tilde{N} defined as $\min\{n \in \mathbb{N}^\gamma : n \geq N\}$. This concludes the proof when f is non-negative. For the general case, we simply decompose f into its positive and negative parts. This concludes the proof of Lemma 3.2.1, and also the proof of Theorem 3.1.1. \square

3.3 Further perspectives

It is possible that a similar result also holds when we consider the joint windings of independent Brownian motions. To be more specific, for two independent planar Brownian motions X, X' , we can define their intersection measure ℓ , which is carried by the plane (see [23]).

One possible way to approximate the mass of this measure is to look at the Lebesgue measure of the intersection of Wiener sausages with small radius ε around X and X' . In [30] (and also in [31]), it is shown that $\ell(\mathbb{R}^2)$ can be obtained as the properly normalized limit of these measures as $\varepsilon \rightarrow 0$.

For two independent planar Brownian motions X, X' , define

$$\mathcal{D}_N^{(2)} = \{z \in \mathbb{R}^2 : \theta_X(z) \geq N, \theta_{X'}(z) \geq N\}.$$

Conjecture 3.3.1. *There exists a constant C which depends only $\|X_0 - X'_0\|$ and such that $CN^2 \mathcal{D}_N^{(2)}$ converges, as $N \rightarrow \infty$, towards $\ell(\mathbb{R}^2)$. The convergence holds both in L^p for any $p \in [1, +\infty)$ and almost surely.*

Besides, almost surely, the measure $CN^2 \mathbb{1}_{\mathcal{D}_N^{(2)}} \, dz$ converges weakly towards ℓ .

For such a result to hold, it is necessary that the exponent of N is equal to 2. Nonetheless, we cannot exclude that some logarithmic corrections should be added.

Chapter 4

Green's formula

We prove an almost sure Green formula for the Brownian motion. We show that, almost surely on the Brownian trajectory, the average winding of random points distributed uniformly over the plane has a Cauchy distribution, centered at the Lévy area of the Brownian motion. We also make a connection with gauge theory.

4.1 Introduction

Let us recall that, in the first chapter, we have shown that the sequence $(ND_N - \frac{1}{2\pi})_{N \in \mathbb{N}}$ converges quickly to 0, almost surely and in L^p for all $p < +\infty$. From these results, we directly deduce that the sum

$$\mathbb{A}^X = \sum_{N=1}^{+\infty} (D_N - D_{-N}) \quad (4.1)$$

is convergent, almost surely and in L^p for all $p < +\infty$.

In this chapter, our goal is to obtain a Green formula, in the spirit of [48]: that is, we want to identify \mathbb{A}^X with a stochastic integral. The following theorem provides this identification, and also proposes a new interpretation for the *area* part of the name *Lévy area*.¹ As opposed to the traditional understanding of this name, ours does not rely on any approximation of the curve. Let us recall that the Cauchy distribution with position parameter $p \in \mathbb{R}$ and scale parameter $\sigma > 0$ is the distribution with density f given by

$$f(x) = \frac{\sigma}{\pi} \frac{1}{(x-p)^2 + \sigma^2}.$$

Theorem 4.1.1. *Let $X = (X^1, X^2) : [0, 1] \rightarrow \mathbb{R}^2$ be a planar Brownian motion. Let \mathbb{A}^X be the sum defined by (4.1).*

◇ *Almost surely, \mathbb{A}^X is equal to the Lévy area*

$$\mathcal{A} = \int_0^1 \frac{X^1 dX^2 - X^2 dX^1}{2}.$$

¹Actually, the author also have a proposition for a new interpretation of the *Lévy part*.

- ◊ Let \mathcal{P} be a Poisson process with intensity $K \, dz$ on a second probability space $(\Omega^{\mathcal{P}}, \mathcal{F}^{\mathcal{P}}, \mathbb{P}^{\mathcal{P}})$. Then, \mathbb{P}^X -almost surely, the sum

$$\frac{1}{K} \sum_{z \in \mathcal{P}} \theta(z)$$

converges in distribution, as $K \rightarrow +\infty$, towards a Cauchy distribution with position parameter \mathbb{A}^X .

In the last section, we extend partially this result to a wide family of differential 1-forms replacing the 1-form $\frac{x \, dy - y \, dx}{2}$.

The second item should be compared with the situation of a smoother curve. Using the Green's formula, it is not very hard to show that the same sum, but with θ replaced by θ^Y for a smooth curve Y , converges in distribution toward a constant, which is the integral of the 1-form $\frac{x \, dy - y \, dx}{2}$ along Y . Heuristically, the fact that the Brownian motion X fails shortly from having a finite 2-variation translates into the fact that the Cauchy distribution fails from having a finite expectation. The possibility to define the stochastic integral anyway translate into the fact that the Cauchy distribution admits a position parameter anyway.

Because it is not explicit in the theorem, we should mention the fact that showing that the problem of showing that $\mathbb{A}^X = \mathcal{A}$ is closely linked to the problem of showing that \mathbb{A}^X satisfies the Chen's relation. Write $\mathbb{A}_{s,t}^X$ for the same quantity as \mathbb{A}^X , but with the winding function θ of X replaced with the winding function of $X|_{[s,t]}$. Then, we say that the collection $(\mathbb{A}_{s,t}^X)_{s \leq t}$ satisfies the Chen's relation if the following equality holds, for all $0 \leq s \leq u \leq t \leq 1$:

$$\mathbb{A}_{s,t}^X = \mathbb{A}_{s,u}^X + \mathbb{A}_{u,t}^X + \frac{(X_t^2 - X_u^2)(X_u^1 - X_s^1) - (X_t^1 - X_u^1)(X_u^2 - X_s^2)}{2}.$$

The stochastic integral does satisfy this relation, and the equality $\mathbb{A}^X = \mathcal{A}$ implies that $(\mathbb{A}_{s,t}^X)_{s \leq t}$ satisfies it too. Actually, we will first show that $(\mathbb{A}_{s,t}^X)_{s \leq t}$ satisfies this relation, and we will deduce from it that the equality $\mathbb{A}^X = \mathcal{A}$ holds. We will prove the Chen's relation by using some properties of Cauchy random variables. This can actually be avoided, as we will see in chapter 6.

4.2 Some general ideas

For $\sigma > 0$ and $p \in \mathbb{R}$, we write $C(p, \sigma)$ the Cauchy distribution with *position parameter* p and *scale parameter* σ . That is, the probability measure on \mathbb{R}

$$C(p, \sigma) = \frac{\sigma}{\pi} \frac{1}{(x - p)^2 + \sigma^2} \, dx$$

We also set $C(p, 0) = \delta_p$. We recall also that, for any p, σ , $C(p, \sigma)$ is a 1-stable law: if X and Y are independent random variables distributed according to $C(p, \sigma)$, then $\frac{X+Y}{2}$ is also distributed according to $C(p, \sigma)$.

A probability measure ν on \mathbb{R} is said to lie in the attraction domain of a Cauchy distribution if there exists sequences $(a_n)_{n \geq 1}$ and $(b_n)_{n \geq 1}$ of reals such that for an i.i.d. sequence $(Z_n)_{n \geq 0}$

with common law ν ,

$$\frac{Z_1 + \dots + Z_n}{a_n} - b_n \xrightarrow[n \rightarrow +\infty]{(d)} C(p, \sigma) \quad (4.2)$$

for some $p \in \mathbb{R}$, $\sigma > 0$.²

It is known that (4.2) is equivalent to some condition about the asymptotics of the tail (see for example [16]). In particular, it is sufficient that the cumulative distribution function F_ν of ν satisfies the two tail conditions

$$1 - F_\nu(x) \underset{x \rightarrow +\infty}{\sim} \frac{\sigma}{\pi x} \quad \text{and} \quad F_\nu(x) \underset{x \rightarrow -\infty}{\sim} -\frac{\sigma}{\pi x}.$$

In this general situation, the position parameter p of the limiting Cauchy distribution has no particular meaning, as it can be changed arbitrarily by shifting the sequence $(b_n)_{n \geq 1}$.

We will make use of the following less common (and more restrictive) definition. We say that a probability measure ν on \mathbb{R} lies in the *strong attraction domain* (of a Cauchy distribution) with scale parameter $\sigma \geq 0$ if there exists $\delta > 0$ such that

$$F_\nu(x) \underset{x \rightarrow -\infty}{=} \frac{\sigma}{\pi|x|} + o\left(\frac{1}{|x|^{1+\delta}}\right) \quad 1 - F_\nu(x) \underset{x \rightarrow +\infty}{=} \frac{\sigma}{\pi x} + o\left(\frac{1}{x^{1+\delta}}\right). \quad (\text{C})$$

We use here the terminology of [28] (Definition 5.2). It is shown in [28, Lemma 5.1] that the condition (C) implies the existence of a Cauchy distribution ν' , a real $\delta > 0$, and a coupling (X, Y) with X distributed according to ν and Y according to ν' , such that $\mathbb{E}[|X - Y|^{1+\delta}]$ is finite. In particular, not only does ν lie in the attraction domain, but the convergence (4.2) holds with the choices $a_n = n$, $b_n = 0$ (see Theorem 1.2 in [28]³).

We then denote by p_ν the position parameter of the limiting Cauchy distribution (for these choices of a_n, b_n), and by σ_ν its scale parameter. The scale parameter σ_ν is also the value of the σ that appears on (C). We call p_ν the *position parameter* of ν , and σ_ν its *scale parameter*. Any distribution with a finite moment of order strictly greater than 1 also satisfies (C) with $\sigma = 0$, and in that case p_ν is equal to the first moment of ν . However, the distributions that satisfies (C) with $\sigma \neq 0$ do not even have a moment of order 1. We will show that when ν lies on the strong attraction domain, p_ν is given by the explicit formulas

$$p_\nu = \sum_{N \geq 1} (\nu([N, +\infty)) - \nu((-\infty, -N])) = \sum_{N \geq 1} N(\nu(N) - \nu(-N)). \quad (4.3)$$

At these stage, the reader should start to recognize the relations between Cauchy distributions and their domains, and the windings of the Brownian motion. Indeed the formula (4.3) is the same as (4.1) if ν is the measure on \mathbb{Z} given by $\nu(\{N\}) = A_N$. These however is not a probability measure, hence we extend the previous definitions to finite positive measures.

If μ is a finite measure with mass Z , and the probability measure $\nu = \frac{\mu}{Z}$ satisfies condition (C), then we set $p_\mu = Zp_\nu$ (resp. $\sigma_\mu = Z\sigma_\nu$) and we call it the position parameter of μ (resp. the

²One cannot include the case $\sigma = 0$ without imposing some restrictions on the sequence $(a_n)_{n \geq 1}$.

³There seems to be a minor mistake in the assumptions of this theorem. The condition “ $\mathbb{E}[X_i] = 0$ if $\alpha > 1$ ” should be replaced with the condition “if $\beta > 1$, there exists an α -stable random variable Y such that $\mathbb{E}[X_i - Y] = 0$ ” in order to deal correctly with the case $\alpha \leq 1 < \beta$. The last inequality on the proof (p. 841) is true only under this stronger condition.

scale parameter of μ). We then say that μ lies on the strong attraction domain of the Cauchy distribution.

For a continuous function $Z : [0, 1] \rightarrow \mathbb{R}^2$ whose range has vanishing Lebesgue measure, we define a measure μ_Z on \mathbb{Z}^* by setting, for all $n \in \mathbb{Z}^*$,

$$\mu_Z(\{n\}) = |\{z \in \mathbb{R}^2 : \theta^Z(z) = n\}|,$$

that is the Lebesgue measure of the set of points with winding n . To shorten notations, we set $p_Z = p_{\mu_Z}$.

We will prove the following statement, from which we will easily deduce Theorem 4.1.1 at the end of the chapter.

Theorem 4.2.1. *Let $X = (X^1, X^2) : [0, 1] \rightarrow \mathbb{R}^2$ be a Brownian motion. With probability 1, the measure μ_X lies in the strong attraction domain of the Cauchy distribution, and the position parameter p_{μ_X} is equal to both \mathbb{A}^X and \mathcal{A} . In particular, these quantities are equal.*

We will write Δ for the set of laws μ which lie on the strong attraction domain of a Cauchy law (that is, those which satisfy Condition (C) after normalization). For a given probability space $(\Omega, \mathcal{F}, \mathbf{P})$, we also set $\Delta(\Omega)$ the set of random variables on Ω whose distribution lies in Δ .

Before we proceed, we should warn the reader about the following facts, which might seem counter-intuitive: if Ω is large enough, the set $\Delta(\Omega)$ is not a linear space. Even worse is the fact that for a general additive subset S of $\Delta(\Omega)$, the map $p : S \rightarrow \mathbb{R}$ which maps a random variable to the position parameter of its law, is *not* additive in general. A counter-example to this was given by Chen and Shepp [9], where S is actually generated by two Cauchy random variables. This is why there is a difficulty in showing the Chen's relation.

In the next section (Section 4.3), we introduce a formula to compute position parameters, and a way to bypass this global lack of additivity. The section that comes after (Section 4.4) is dedicated to the computation of the position parameter for the Brownian motion.

4.3 Some properties of Cauchy-like laws

We will need the two following lemma, whose proofs, given below, consists in simple computations. In what follows, $(\Omega, \mathcal{F}, \mathbf{P})$ is a fixed probability space.

Lemma 4.3.1. *Consider $X \in \Delta(\Omega)$. Let p be its position parameter. For two real numbers a, k with $k > 0$, let also $(a)_k$ denote the quantity $\max(\min(a, k), -k)$. Then, we have the following equalities:*

$$p = \lim_{N \rightarrow \infty} N \mathbf{E} [\sin(X/N)] = \lim_{k \rightarrow \infty} \mathbf{E} [X \mathbb{1}_{|X| \leq k}] = \lim_{k \rightarrow \infty} \mathbf{E} [(X)_k].$$

This lemma will allow us to express the position parameter p_B in terms of the sequence D_N . We will also need the second following lemma, which roughly speaking states that the position parameters do add up as soon as the corresponding variables are not too strongly correlated in their tail behaviour.

Lemma 4.3.2. *Let $n \in \mathbb{N}$ and $X_1, \dots, X_n \in \Delta(\Omega)$ with position parameters p_1, \dots, p_n . Assume that there exists $\delta > 0$ such that, for all $i, j \in \{1, \dots, n\}$, $i \neq j$,*

$$\mathbf{P}(|X_i| \geq x, |X_j| \geq x) = o(x^{-(1+\delta)}) \quad \text{as } x \rightarrow +\infty.$$

Then $\sum_{i=1}^n X_i \in \Delta(\Omega)$ and its position parameter p is equal to $\sum_{i=1}^n p_i$.

Proof of Lemma 4.3.1. The first equality is a known result (see, for example [16], Part XVII, Theorem 3 p. 580, and conclusive remark p. 581), and relies on the study of the characteristic function of X . Let μ be the law of X . Let F denote its cumulative distribution function, and set $F^-(x) = F(-x)$. Let $p_N = N\mathbf{E}[\sin(X/N)]$. Then,

$$\begin{aligned} p_N &= \lim_{k \rightarrow +\infty} \int_{-k}^k N \sin(x/N) dF(x) \\ &= \lim_{k \rightarrow +\infty} \int_0^k N \sin(x/N) d(1 + F - F^-)(x) \\ &= \lim_{k \rightarrow +\infty} \left(N \sin(k/N)(1 + F - F^-)(k) - \int_0^k \cos(x/N)(1 + F - F^-)(x) dx \right). \end{aligned}$$

From the fact that μ lies in the strong attraction domain, we deduce that, for some $\varepsilon > 0$,

$$1 + F(x) - F(-x) = o(x^{-1-\varepsilon}). \quad (4.4)$$

It follows that

$$|N \sin(k/N)(1 + F - F^-)(k)| \leq k|(1 + F - F^-)(k)| = o(1),$$

so that

$$p_N = - \int_0^\infty \mathbb{1}_{x \leq N} \cos(x/N)(1 + F(x) - F^-(x)) dx.$$

The integrand is dominated by the integrable function $1 + F - F^-$, and from pointwise convergence it follows that

$$p = \lim_{N \rightarrow \infty} p_N = - \int_0^\infty (1 + F(x) - F^-(x)) dx.$$

Besides,

$$\begin{aligned} \mathbf{E}[X \mathbb{1}_{|X| \leq k}] &= \int_{-k}^k x dF(x) \\ &= \int_0^k x d(1 + F - F^-)(x) \\ &= k(1 - F(k) - F(-k)) - \int_0^k (1 + F(x) - F^-(x)) dx \\ &\xrightarrow[k \rightarrow +\infty]{} - \int_0^\infty (1 + F(x) - F^-(x)) dx \quad (\text{using (4.4) once again}). \end{aligned}$$

This implies the second equality.

For the third equality, it suffices to remark that

$$\mathbf{E}[(X)_k] - \mathbf{E}[X \mathbb{1}_{|X| \leq k}] = k(\mathbb{P}(X \geq k) - \mathbb{P}(X \leq -k)) \xrightarrow[k \rightarrow +\infty]{} 0.$$

The proof is complete. \square

Proof of Lemma 4.3.2. We first assume $n = 2$. We set a_1, a_2 and γ such that

$$\mathbf{P}(X_i \geq x) \underset{x \rightarrow +\infty}{=} \frac{a_i}{x} + o(x^{-1-\gamma}).$$

We also fix $\varepsilon : 0 < \varepsilon < 1 - \frac{1}{1+\delta}$, and assume $x^\varepsilon > 3$. We first show that $X_1 + X_2$ lies on $\Delta(\Omega)$:

$$\begin{aligned} \mathbf{P}(X_1 + X_2 \geq x) &\geq \mathbf{P}(X_1 + X_2 \geq x \text{ and } |X_2| \leq x^{1-\varepsilon}) \\ &\quad + \mathbf{P}(X_1 + X_2 \geq x \text{ and } |X_1| \leq x^{1-\varepsilon}) \\ &\geq \mathbf{P}(X_1 \geq x + x^{1-\varepsilon}) - \mathbf{P}(X_1 \geq x + x^{1-\varepsilon}, |X_2| \geq x^{1-\varepsilon}) \\ &\quad + \mathbf{P}(X_2 \geq x + x^{1-\varepsilon}) - \mathbf{P}(X_2 \geq x + x^{1-\varepsilon}, |X_1| \geq x^{1-\varepsilon}) \\ &\geq \frac{a_1 + a_2}{x} + O(x^{-1-\varepsilon}) + O(x^{-1-\gamma}) + O(x^{-(1-\varepsilon)(1+\delta)}). \end{aligned}$$

Besides,

$$\begin{aligned} \mathbf{P}(X_1 + X_2 \geq x) &\leq \mathbf{P}(X_1 \geq x - x^{1-\varepsilon}) + \mathbf{P}(X_2 \geq x - x^{1-\varepsilon}) + \mathbf{P}(X_1 \geq x^{1-\varepsilon} \text{ and } X_2 \geq x^{1-\varepsilon}) \\ &\leq \frac{a_1 + a_2}{x} + O(x^{-1-\varepsilon}) + O(x^{-1-\gamma}) + O(x^{-(1-\varepsilon)(1+\delta)}). \end{aligned}$$

The estimation near $-\infty$ is identical, and it follows that $X_1 + X_2$ lies on $\Delta(\Omega)$. To show that $p = p_1 + p_2$, we use Lemma 4.3.1. We write $k^\pm = k \pm k^{1-\varepsilon}$.

Then,

$$\begin{aligned} &\{X_1 \geq 0, |X_1 + X_2| \leq k^-\} \setminus \{X_1 \geq 0, |X_2| \geq k^{1-\varepsilon}, |X_1 + X_2| \leq k^-\} \\ &\subseteq \{X_1 \in [0, k]\} \\ &\subseteq \{X_1 \geq 0, |X_1 + X_2| \leq k^+\} \cup \{X_1 \in [0, k^{1-\varepsilon}], |X_2| \geq k\} \cup \{X_1 \in [k^{1-\varepsilon}, k], |X_2| \geq k^{1-\varepsilon}\}, \end{aligned}$$

so that

$$\begin{aligned} \mathbf{E}[X_1 \mathbb{1}_{X_1 \in [0, k]}] &\leq \mathbf{E}[X_1 \mathbb{1}_{X_1 \in [0, k], |X_1 + X_2| \leq k^+}] \\ &\quad + k^{1-\varepsilon} \mathbf{P}(\{|X_2| \geq k\}) + k \mathbf{P}(|X_1| \geq k^{1-\varepsilon} \text{ and } |X_2| \geq k^{1-\varepsilon}) \\ &\leq \mathbf{E}[X_1 \mathbb{1}_{X_1 \in [0, k], |X_1 + X_2| \leq k^+}] + k^{-\varepsilon} + k^{1-(1-\varepsilon)(1+\delta)}, \end{aligned} \tag{4.5}$$

and

$$\mathbf{E}[X_1 \mathbb{1}_{X_1 \in [0, k]}] \geq \mathbf{E}[X_1 \mathbb{1}_{X_1 \geq 0, |X_1 + X_2| \leq k^-}] - \mathbf{E}[X_1 \mathbb{1}_{|X_2| \geq k^{1-\varepsilon}, |X_1 + X_2| \leq k^-}].$$

To bound the last term, we introduce some ε' such that $\varepsilon < \varepsilon' < 1 - \frac{1}{1+\delta}$, and we separate the events $\{X_1 \leq k^{1-\varepsilon'}\}$, $\{X_1 > k^{1-\varepsilon'}\}$. We obtain

$$\mathbf{E}[X_1 \mathbb{1}_{|X_2| \geq k^{1-\varepsilon}, |X_1 + X_2| \leq k^-}] \leq k^{1-\varepsilon'} \mathbf{P}(|X_2| \geq k^{1-\varepsilon}) + k \mathbf{P}(|X_1| \geq k^{1-\varepsilon'} \text{ and } |X_2| \geq k^{1-\varepsilon}),$$

which is less than $k^{\varepsilon-\varepsilon'} + k^{1-(1-\varepsilon')(1+\delta)}$. Thus,

$$\mathbf{E}[X_1 \mathbb{1}_{X_1 \in [0, k]}] \geq \mathbf{E}[X_1 \mathbb{1}_{X_1 \geq 0, |X_1 + X_2| \leq k^-}] - k^{\varepsilon-\varepsilon'} - k^{1-(1-\varepsilon')(1+\delta)}. \quad (4.6)$$

Finally, writing F for the cumulative distribution function of X_1 , we have

$$\begin{aligned} \mathbf{E}[X_1 \mathbb{1}_{X_1 \geq 0, |X_1 + X_2| \in [k^-, k^+]}] &\leq k^{1-\varepsilon} \mathbf{P}(|X_2| \geq k - 2k^{1-\varepsilon}) \\ &\quad + (k + 2k^{1-\varepsilon}) \mathbf{P}(X_1 \in [k^{1-\varepsilon}, k + 2k^{1-\varepsilon}], X_2 \geq k^{1-\varepsilon}) \\ &\quad + (k + 2k^{1-\varepsilon}) \mathbf{P}(X_1 \in [k - 2k^{1-\varepsilon}, k + 2k^{1-\varepsilon}]) \\ &\leq C(k^{-\varepsilon} + k^{1-(1-\varepsilon)(1+\delta)}) + k(F(k + 2k^{1-\varepsilon}) - F(k - 2k^{1-\varepsilon})) \\ &\leq C'(k^{-\varepsilon} + k^{1-(1-\varepsilon)(1+\delta)}) + k(k^{\varepsilon-2} + k^{-1-\gamma}). \end{aligned} \quad (4.7)$$

With (4.5), (4.6) and (4.7), we obtain

$$\mathbf{E}[X_1 \mathbb{1}_{X_1 \in [0, k]}] = \mathbf{E}[X_1 \mathbb{1}_{X_1 \in [0, k], |X_1 + X_2| \leq k^+}] + O(x^{-\xi})$$

where $\xi = \min(\varepsilon - \varepsilon', \gamma, 1 - \varepsilon, (1 - \varepsilon')(1 + \delta) - 1) > 0$. We do the same thing with $(-X_1, X_2)$, (X_2, X_1) , and $(-X_2, X_1)$ instead of (X_1, X_2) , and we obtain

$$\mathbf{E}[X_1 \mathbb{1}_{|X_1| \leq k}] + \mathbf{E}[X_2 \mathbb{1}_{|X_2| \leq k}] - \mathbf{E}[(X_1 + X_2) \mathbb{1}_{|X_1 + X_2| \leq k^+}] = O(x^{-\xi}) = o(1).$$

Taking the limit $k \rightarrow +\infty$, we obtain $p_1 + p_2 - p = 0$.

The proof is now complete in the case $n = 2$, and the inequality

$$\mathbf{P}\left(|X_n| \geq x \text{ and } \left|\sum_{i=1}^{n-1} X_i\right| \geq x\right) \leq \mathbf{P}\left(|X_n| \geq \frac{x}{n} \text{ and } \exists i \in \{1, \dots, n-1\} : |X_i| \geq \frac{x}{n}\right).$$

allows us to extend, by induction, the result to an arbitrary number of random variables. \square

4.4 Computation of the position parameter

We now have the tools to show the first part of Theorem 4.1.1, which roughly state that the Green formula holds, that is: the sum \mathbb{A}^X is equal to the Lévy area \mathcal{A} .

Proof. It is clear, by symmetry of the Brownian motion, that D_{-N} is equal in distribution to D_N , and thus satisfies the same estimates. Using Lemma 4.3.1 (which extends directly to the case of measures with finite mass), we have

$$\mathbb{E}[|p_X|] = \mathbb{E}\left[\left|\sum_{N=1}^{\infty} (D_N - D_{-N})\right|\right].$$

We recall that the dominant term in the asymptotic expansion of D_N cancels with the one of D_{-N} , so that it is the second order term which is relevant here. We use the L^1 estimation given by Theorem 2.1.1. For some arbitrary $\delta \in (0, \frac{1}{2})$, for some constant C , for all $N \geq 1$,

$$\mathbb{E}[|D_N - D_{-N}|] \leq CN^{-1-\delta},$$

and it follows that

$$\mathbb{E}[|p_X|] \leq \sum_{N=1}^{\infty} CN^{-1-\delta} < +\infty.$$

Let us denote by $X^{pl,n}$ the dyadic piecewise linear approximation of X with 2^n steps: for $i \in \{0, 1, \dots, 2^n - 1\}$ and $u \in [0, 1)$,

$$X_{\frac{i+u}{2^n}}^{pl,n} = X_{\frac{i}{2^n}} + u(X_{\frac{i+1}{2^n}} - X_{\frac{i}{2^n}}).$$

We also let $X(i, n)$ be the restriction of X to the interval $[\frac{i-1}{2^n}, \frac{i}{2^n}]$, so that

$$\theta = \theta^{X^{pl,n}} + \sum_{i=1}^{2^n} \theta^{X(i,n)}.$$

Let us assume that the equality holds at the level of position parameters, that is

$$p_X = p_{X^{pl,n}} + \sum_{i=1}^{2^n} p_{X(i,n)}. \quad (\star)$$

Since the function $\theta^{X^{pl,n}}$ is bounded, it is easy to see that $p_{X^{pl,n}} = \int_{\mathbb{R}^2} \theta^{X^{pl,n}}$, and that this is equal to $\mathcal{A}_{X^{pl,n}}$. It is widely known, from the early introduction of the Lévy area, that $\mathcal{A}_{X^{pl,n}}$ converges toward \mathcal{A}_X , in the almost sure sense, as $n \rightarrow \infty$. Thus, under the assumption (\star) , the conclusion would follow from

$$\sum_{i=1}^{2^n} p_{X(i,n)} \xrightarrow[n \rightarrow \infty]{p.s.} 0. \quad (4.8)$$

Since we already know that

$$\sum_{i=1}^{2^n} p_{X(i,n)} \xrightarrow[n \rightarrow \infty]{p.s.} p_B - \mathcal{A}_X,$$

it is actually sufficient to show that the convergence (4.8) holds in distribution. Remark that the curves $(X(i, n) - X_{\frac{i-1}{2^n}})_{i \in \{1, \dots, 2^n\}}$ are i.i.d. Brownian motions, so that their position parameters are i.i.d. variables. Their position parameters $p_{X(i,n)}$ are equal in distribution to $\frac{p_X}{2^n}$, because of the scaling property of Brownian motion. Since p_X has finite expectation, the weak law of large numbers applies and ensures that $\sum_{i=1}^{2^n} p_{X(i,n)}$ converges in distribution towards the expectation of p_X . By symmetry of the Brownian motion, this expectation is zero, which implies (4.8). Remark that the strong law of large numbers does not apply directly, because we have a triangular array instead of a sequence of random variables.

There is only (\star) left to show.

Remark first that for any two curves γ, γ' , if γ lies in the strong attraction domain of the Cauchy law and $\mu_{\gamma'}$ admits a first moment, then $\gamma \cdot \gamma'$ lies in the strong attraction domain of the Cauchy law, and $p_{\gamma \cdot \gamma'} = p_{\gamma} + p_{\gamma'}$. This follows directly from Slutsky's Lemma.

Since $\theta^{X^{pl,n}}$ is a bounded function, $\mu_{\gamma'}$ admits a first moment (recall that n is fixed here). We let $(X^{pl,n})^{-1}$ be the curve $X^{pl,n}$ with reversed orientation, and $X \cdot (X^{pl,n})^{-1}$ be the concatenation of X and $(X^{pl,n})^{-1}$, so that

$$p_X = p_{X \cdot (X^{pl,n})^{-1}} + p_{X^{pl,n}}.$$

Remark that the following equality holds almost everywhere

$$\theta^{X \cdot (X^{pl,n})} = \sum_{i=1}^{2^n} \theta^{X(i,n)}.$$

We now want to apply Lemma 4.3.2.

Let (R_1, \dots, R_{2^n}) be a family of \mathbb{Z} -valued random variables such that

$$\mathbf{P}((R_1, \dots, R_{2^n}) = (0, \dots, 0)) = 0$$

and for any $(k_1, \dots, k_{2^n}) \in \mathbb{Z}^{2^n} \setminus \{0\}$,

$$\mathbf{P}((R_1, \dots, R_{2^n}) = (k_1, \dots, k_{2^n})) = \frac{1}{Z} |\{z \in \mathbb{R}^2 : \forall i \in \{1, \dots, 2^n\}, \theta^{X(i,n)}(z) = k_i\}|,$$

where the normalizing constant Z is such that \mathbf{P} is a probability measure.

For $i, j \in \{1, \dots, 2^n\}$, $i \neq j$, set

$$\begin{aligned} D_{N,N}^{i,j,n} &= |\{z \in \mathbb{R}^2 : |\theta^{X(i,n)}(z)| \geq N \text{ and } |\theta^{X(j,n)}(z)| \geq N\}| \\ &= Z \mathbf{P}(|R_i| \geq N \text{ and } |R_j| \geq N). \end{aligned}$$

Then, for $\delta, \varepsilon > 0$ such that $2\delta + \varepsilon < 2$,

$$\begin{aligned} \mathbb{P}(\exists N \geq N_0 : D_{N,N}^{i,j,n} \geq N^{-1-\delta}) &\leq \sum_{k=\lfloor \log_2(N_0) \rfloor}^{\infty} \mathbb{P}(D_{2^k, 2^k}^{i,j,n} \geq 2^{(k+1)(-1-\delta)}) \\ &\leq \sum_{k=\lfloor \log_2(N_0) \rfloor}^{\infty} 2^{2(k+1)(1+\delta)} \mathbb{E} \left[(D_{2^k, 2^k}^{i,j,n})^2 \right] \\ &\leq \sum_{k=\lfloor \log_2(N_0) \rfloor}^{\infty} C 2^{-2n} 2^{2k(1+\delta)} 2^{k(-4+\varepsilon)} \\ &\xrightarrow{N_0 \rightarrow +\infty} 0. \end{aligned} \tag{4.9}$$

This implies that, for all n, i, j , \mathbb{P} -almost surely, the hypothesis of Lemma 4.3.2 is satisfied for (R_1, \dots, R_{2^n}) (under \mathbf{P}). Thus, \mathbb{P} -almost surely, (\star) holds. This ends the proof that the Green formula holds. \square

4.5 Proof of Theorem 4.1.1

The goal of this section is to show that Theorem 4.2.1 does imply Theorem 4.1.1, as we announced earlier. We first show the following lemma.

Lemma 4.5.1. *Let $(R_i)_{i \in \mathbb{N}}$ be a family of i.i.d. random variables. For any $N \in \mathbb{N}$, let $P(N)$ be a Poisson random variable with parameter N and independent from the family $(R_i)_{i \in \mathbb{N}}$. Assume that the random variables*

$$S_N = \frac{1}{N} \sum_{i=1}^N R_i$$

converge in distribution as $N \rightarrow +\infty$. Then,

$$\tilde{S}_N = \frac{1}{N} \sum_{i=1}^{P(N)} R_i$$

also converge in distribution as $N \rightarrow +\infty$, and the limiting distributions are the same.

Proof. Let ϕ (resp. $\phi_N, \tilde{\phi}_N$) be the characteristic function of R_i (resp. S_N, \tilde{S}_N). Set also ϕ_∞ the characteristic function of the limit distribution of the S_N .

Let $\theta \in \mathbb{R}$ and set $u_N = \phi(\frac{\theta}{N})$. As $N \rightarrow \infty$, $u_N \rightarrow \phi(0) = 1$. Hence $u_N - 1 \underset{N \rightarrow \infty}{\sim} \text{Log}(u_N)$ where Log is a determination of the logarithm continuous at 1 and with $\text{Log}(1) = 0$. Then

$$N(u_N - 1) \underset{N \rightarrow \infty}{\sim} N \text{Log}(u_N).$$

In $\mathbb{C}/2i\pi\mathbb{Z}$, for N large enough, $u_N \neq 0$ and then $N \text{Log}(u_N) = \text{Log}(u_N^N) = \text{Log}(\phi_N(\theta))$. The assumption of the lemma ensures that $\phi_N(\theta) \underset{N \rightarrow \infty}{\rightarrow} \phi_\infty(\theta)$. Hence, in $\mathbb{C}/2i\pi\mathbb{Z}$,

$$N(u_N - 1) \underset{N \rightarrow \infty}{\rightarrow} \text{Log}(\phi_\infty(\theta)).$$

It follows that $\exp(N(u_N - 1)) \underset{N \rightarrow \infty}{\rightarrow} \phi_\infty(\theta)$. The random variable \tilde{S}_N is a compound Poisson variable, and $\tilde{\phi}_N(\theta)$ is equal to $\exp(N(u_N - 1))$, so $\tilde{\phi}_N(\theta) \underset{N \rightarrow \infty}{\rightarrow} \phi_\infty(\theta)$. Since this is true for any $\theta \in \mathbb{R}$, the conclusion of the lemma follows from the Lévy's continuity theorem. \square

We now start the proof of Theorem 4.1.1.

Proof. Let Ω_0 be the full probability event of Theorem 4.2.1. It is a subset of the probability space Ω in which the Brownian motion is defined. We set $\omega \in \Omega_0$.

Set $R = \sup_{t \in [0,1]} \|X_t(\omega)\|$ and ν_R the probability law defined in \mathbb{Z} (including 0) by

$$\nu_R(N) = \frac{|\{z \in B(0, R) \setminus \text{Range}(X(\omega)) : \theta^{X(\omega)}(z) = N\}|}{|B(0, R)|}.$$

The probability law is related to the probability law $\nu_{X(\omega)}$ by the relation

$$\nu_R(N) = \frac{Z}{|B(0, R)|} \nu_{X(\omega)} + \frac{|B(0, R)| - Z}{|B(0, R)|} \delta_0 \quad (4.10)$$

with Z the mass of $\mu_{X(\omega)}$.

We denote by N_K the cardinal of $\mathcal{P}(K) \cap B(0, R)$, which is a Poisson random variable with parameter $|B(0, R)|K$. Set $(R_i)_{i \in \mathbb{N}}$ a family of i.i.d. random variables distributed as ν_R , and independent from N_K . Then,

$$\sum_{z \in \mathcal{P}(K)} \theta^{X(\omega)}(z) = \sum_{z \in \mathcal{P}(K) \cap B(0, R)} \theta^{X(\omega)}(z) \stackrel{(d)}{=} \sum_{i=1}^{N_K} R_i \quad (4.11)$$

Using (4.10), we can write $R_i = B_i Q_i$ where the B_i are Bernoulli's random variables with parameter $\frac{Z}{|B(0, R)|}$, the Q_i are distributed as $\nu_{X(\omega)}$ and B_i is independent from Q_i . Since the R_i, N_K are globally independent, we can further assume that the B_i, Q_i, N_K are also globally independent. Set $M_K = |\{i \in \{1, \dots, N_K\} : B_i = 1\}|$, which is easily seen to be a Poisson random variable with parameter ZK . Then,

$$\sum_{i=1}^{N_K} R_i \stackrel{(d)}{=} \sum_{i=1}^{M_K} Q_i. \quad (4.12)$$

Theorem 4.2.1 implies that $\sum_{i=1}^{ZK} Q_i$ converges in distribution toward a Cauchy distribution with position parameter $p_{X(\omega)}$. Lemma 4.5.1 then implies that $\sum_{i=1}^{M_K} Q_i$ also converges in distribution toward a Cauchy distribution with position parameter $p_{X(\omega)}$. Together with (4.11) and (4.12), we obtain Theorem 4.1.1. \square

4.6 Extension to general 1-forms

In this section, we show that it is possible to extend the previous result to a wide class of differential 1-forms.

Theorem 4.6.1. *Let $\beta > 0$ and η a $\mathcal{C}^{1+\beta}$ -differential 1-form.*

\diamond *The sequence*

$$\int_{\mathbb{R}^2} [\theta(z)]_k \, d\eta$$

converges almost surely, as $k \rightarrow \infty$. Let \mathbb{A}_η^X be the limit.

\diamond *Let η^+, η^- be two $\mathcal{C}^{1+\beta}$ -differential 1-forms with $d\eta^+, d\eta^- > 0$ and $\eta = \eta^+ - \eta^-$. Let $\mathcal{P}^+, \mathcal{P}^-$ be two independent Poisson process, defined on $(\omega^{\mathcal{P}}, \mathcal{F}^{\mathcal{P}}, \mathbb{P}^{\mathcal{P}})$, and with intensities $K \, d\eta^+$ and $K \, d\eta^-$. Then, \mathbb{P}^X -almost surely, the sum*

$$\frac{1}{K} \left(\sum_{z \in \mathcal{P}^+} \theta(z) - \sum_{z \in \mathcal{P}^-} \theta(z) \right)$$

converges in distribution, as $K \rightarrow +\infty$, towards a Cauchy distribution with parameter \mathbb{A}_η^X .

To be specific, we use the notation $d\eta > 0$ if $d\eta = f \, dx \wedge dy$ with $f > 0$. This result can be reduced to the following one.

Theorem 4.6.2. *Let $\beta > 0$ and ϕ an orientation-preserving homeomorphism of \mathbb{R}^2 , which is \mathcal{C}^β -Hölder continuous.*

◇ The sequence

$$\int_{\mathbb{R}^2} [\theta(\phi^{-1}(z))]_k \, dz$$

converges almost surely as $k \rightarrow \infty$. Let \mathbb{A}_ϕ^X be the limit.

◇ Let \mathcal{P} be a Poisson process, defined on $(\omega^{\mathcal{P}}, \mathcal{F}^{\mathcal{P}}, \mathbb{P}^{\mathcal{P}})$, and with intensities $K \, d\phi$. Then, \mathbb{P}^X -almost surely, the sum

$$\frac{1}{K} \sum_{z \in \mathcal{P}} \theta(z)$$

converges in distribution, as $K \rightarrow +\infty$, towards a Cauchy distribution with parameter \mathbb{A}_ϕ^X .

Let us first explain why this reduction is possible. First, remark that we can always decompose find a decomposition $\eta = \eta^+ - \eta^-$ as in Theorem 4.6.1. This holds, for example, with $\eta^- = f x \, dy$ for a smooth function f large enough (since our problem is local by nature, one can actually take f to be constant). One can thus assume that $d\eta$ is positive. Then, Theorem 4.6.1 follows from Theorem 4.6.2 thanks to the celebrated Moser's theorem. Roughly speaking, this theorem states that any two volume forms ω_0, ω_1 with same total volume are related by $\omega_0 = \phi_*(\omega_1)$ for some diffeomorphism ϕ . The initial result in [38] is given in a smooth framework, but it has since been extended.

Theorem 4.6.3 ([12]). *Let ω be a volume form with regularity \mathcal{C}^β , $\beta \in (0, 1)$, and $r > 0$. Then, there exists $R' > 0$ and a $\mathcal{C}^{1+\beta}$ -diffeomorphism $\phi : B(0, R) \rightarrow B(0, R')$ such that $\phi_*(\omega) = dx \wedge dy$.*

Finally, Theorem 4.6.2 can be deduced from the following lemma, with the exact same arguments as the one we used for the case $\phi = \text{id}$ that we treated before.

Lemma 4.6.4. *Let $\beta > 0$ and ϕ an orientation-preserving homeomorphism of \mathbb{R}^2 , which is \mathcal{C}^β -Hölder continuous. Then, there exists $\delta > 0$ and $C > 0$ such that*

$$N^\delta |N\phi(\mathcal{D}_{\pm N}) - C|$$

converges almost surely to 0 as $N \rightarrow +\infty$.

The constant C is given by

$$C = \frac{1}{2\pi} \int_0^1 J_\phi(X_t) \, dt,$$

where J_ϕ is the jacobian determinant of ϕ .

It only remains to show 4.6.4.

proof of Lemma 4.6.4. The Lebesgue measure of $\phi(\mathcal{D}_N)$ is equal to the integral of J_ϕ over \mathcal{D}_N . Following the notation of Section 3.2, this is $J_\phi(\mathcal{D}_N)$. Lemma 4.6.4 is then a direct application of Lemma 3.2.1, with $f = J_\phi$, and using the fact that the continuity modulus $\omega_f(x)$ is less than $x^\beta \|f\|_{\mathcal{C}^\beta}$ for all x . \square

Remarks 4.6.5. *Some explicit bound on δ can be given, depending on β .*

Some additional properties of \mathbb{A}_η^X can be proved, such as the fact that the collection $(\mathbb{A}_{\eta,s,t}^X)_{s,t} = (\mathbb{A}_\eta^{X|[s,t]})_{s,t}$ admits a continuous and Hölder continuous modification, which satisfies a Chen's-type relation

$$\mathbb{A}_{\eta,s,t}^X = \mathbb{A}_{\eta,s,u}^X + \mathbb{A}_{\eta,u,t}^X + d\eta(T_{s,u,t}),$$

where $T_{s,u,t}$ is the oriented convex hull of the points X_s, X_u, X_t .

Nonetheless, it misses us a correct approximation property. We do have an approximation property, but where the path X is approximated by $\phi^{-1}(\tilde{X})$, with \tilde{X} a linear by part approximation of $\phi(X)$.

In the case η is replaced with a \mathcal{C}^1 differential form, or even with a $W^{1,2}$ -differential form, it is plausible that the convergence of the symmetric sums still holds, but that the part about Poisson processes collapses.

When α is \mathcal{C}^2 , it is certainly possible and not very hard to identify $\mathbb{A}_{\eta,0,t}^X$ with the usual Stratonovich integral of η along X , plus the integral of η along the segment $[X_t, X_0]$. When α is not \mathcal{C}^2 anymore, we leave the framework of semimartingales, but we stay in the framework of Dirichlet processes (that is, $\phi(X)$ is still a Dirichlet process), so that it is still probably possible to identify $\mathbb{A}_{\eta,0,t}^X$ with some integral defined for such processes.

4.7 Relation with Abelian gauge theory

Instead of the Poisson process on \mathbb{R}^2 of Theorem 4.1.1, we can consider the following slight generalization. Fix a probability measure ν on \mathbb{R} with compact support. Let then \mathcal{P} be a Poisson process on $\mathbb{R}^2 \times \mathbb{R}$ with intensity $K dz \otimes d\nu$. For any smooth enough loop Z , we can look at the 'weighted' average sum

$$H(Z) = \frac{1}{K} \sum_{(z,\rho) \in \mathcal{P}} \rho \theta^Z(z). \quad (4.13)$$

Here 'loop' mean that the terminal value is equal to the value at time 0. Smooth enough means that the Lebesgue measure of the range is vanishing, so that θ^Z is defined almost everywhere. Then, we deduce from Theorem 4.1.1 that for a Brownian motion X , concatenated as usual with the straight line segment between the endpoints, $h(X)$ converges (\mathbb{P}^X almost surely on the Brownian motion, in distribution), when K goes to infinity, toward a Cauchy law. The position and scale parameters depends on the Lévy area of the Brownian motion, on the expectation of ν , and also on $\int |x| d\nu(x)$.

We now consider the situation when ν is symmetric around 0, in which case the position parameter vanishes. In that case, for any function Y which is α -Hölder continuous for some $\alpha > \frac{1}{2}$, $S(Y)$ converges in distribution toward 0.

The quantity $h(Z) = \exp(iH(Z))$ can be written

$$h(Z) = \prod_{(z,\rho) \in \mathcal{P}} \exp\left(i \frac{\rho \theta^Z(z)}{K}\right).$$

This transformation is less superficial than it might appears: we are now working in the Lie group $U(1)$ instead of its lie algebra \mathbb{R} . Actually, the map h , defined on the loops starting

from 0, is the holonomy function of some flat connection over the trivial ramified $U(1)$ -bundle $U(1) \times (\mathbb{R}^2 \setminus \pi_{\mathbb{R}^2}(\mathcal{P}))$ over \mathbb{R}^2 . This holonomy function determines the connection up to gauge equivalence.

Remark that the law of h is invariant by volume-preserving diffeomorphisms of the plane.

This model might seem a bit odd to build up random connections, since for all smooth enough curve Z , in the limit $K \rightarrow \infty$, we have $h(Z) \rightarrow 0$.

In order to truly appreciate the gauge theoretic flavour, one should adopt a different scaling. Keeping the intensity of \mathcal{P} as $K \, dz \otimes d\nu$, we define

$$\tilde{h}(Z) = \prod_{(z,\rho) \in \mathcal{P}} \exp\left(i \frac{\rho \theta^Z(z)}{\sqrt{K}}\right),$$

with now \sqrt{K} replacing K .

Theorem 4.7.1. *Let $Y_1, \dots, Y_n : [0, 1] \rightarrow \mathbb{R}^2$ be piecewise-linear loops. Then, the family $(\tilde{h}(Z_1), \dots, \tilde{h}(Z_n))$ converges in distribution, when K goes to infinity. The limit is distributed as $(\text{hol}(Z_1), \dots, \text{hol}(Z_n))$, where hol is a Yang-Mills field on the trivial $U(1)$ -bundle over the plane.*

For the definition of the Yang-Mills field, and for some details about the definitions we will now outline, we refer to [34].⁴

We restrict ourselves to the framework of piecewise-linear (PL) functions from $[0, 1]$ to \mathbb{R}^2 , considered up to precomposition by non-increasing surjective functions from $[0, 1]$ to itself.

For a PL loop ℓ , $\text{hol}(\ell)$ is distributed as $\exp(i\mathcal{N})$, for a centered Gaussian variable \mathcal{N} with variance $\lambda \|\theta^\ell\|_{L^2}^2$, for some constant λ .

For a PL function ℓ , the PL function ℓ^{-1} is obtained by precomposition of ℓ with the application $t \mapsto 1 - t$.

Tree-like equivalence is the equivalence relation, on the set of PL loops starting from 0, which is generated by the relations $\ell\ell^{-1} = \ell^{-1}\ell = 1$. The set of equivalence classes is a group under concatenation, and the inverse of the class $[\ell]$ is given by $[\ell^{-1}]$. We denote by \mathcal{L} this group.

The maps \tilde{h} and hol pass to the quotient into maps from \mathcal{L} to $U(1)$.

A PL lasso is a concatenation cbc^{-1} , where b is a PL loop which is simple (i.e. without self-intersections) and c is a simple PL path starting from 0.

Proof of Theorem 4.7.1. The set of (classes of) PL lasso generates \mathcal{L} , and for any finite family $[\ell_1], \dots, [\ell_n] \in \mathcal{L}$, we can actually find a family of lassos

$$a_1 = c_1 b_1 c_1^{-1}, \dots, a_k = c_k b_k c_k^{-1},$$

a family of indices

$$i_{1,1}, \dots, i_{1,j_1}, i_{2,1}, \dots, i_{n,j_n} \in \mathbb{Z}$$

and a family of exponents

$$\varepsilon_{1,1}, \dots, \varepsilon_{1,j_1}, \varepsilon_{2,1}, \dots, \varepsilon_{n,j_n} \in \{-1, 1\}$$

such that:

⁴The Yang-Mills field is here constructed on compact surfaces, but the tools are also appropriate to study the much simpler situation of the plane.

- ◊ for all $m \in \{1, \dots, n\}$, $[\ell_m] = [a_{m,1}^{\varepsilon_{m,1}}] \dots [a_{m,j_m}^{\varepsilon_{m,1}}]$,
- ◊ the bounded connected components C_1, \dots, C_n delimited by b_1, \dots, b_n are pairwise disjoint.

In particular, to show Theorem 4.7.1, one can restrict oneself to the case when ℓ_1, \dots, ℓ_n are lassos delimiting pairwise disjoint bounded connected components C_1, \dots, C_n .

In such a case, the random variables $\text{hol}(\ell_1), \dots, \text{hol}(\ell_n)$ are pairwise disjoint. The properties of Poisson processes are such that the sums $\tilde{h}(\ell_i)$, indexed by $i \in \{1, \dots, n\}$, are also independent. Hence, to show Theorem 4.7.1, one can restrict oneself to the case when $n = 1$ and ℓ_1 is a lasso.

In that case of a single lasso ℓ with lasso decomposition $\ell = cbc^{-1}$, $\|\theta^\ell\|_{L^2}^2$ is equal to the Lebesgue measure $|C|$ of the bounded component C delimited by b . It thus suffices to show that

$$\frac{1}{\sqrt{K}} \sum_{(z,\rho) \in \mathcal{P}} \rho \theta^Z(z)$$

converges in distribution, when K goes to infinity, toward a gaussian variable with variance proportional to $|C|$ (with a proportionality constant that depends on the probability measure ν). This follows directly from the central limit theorem. \square

On the Brownian case, what we have done implies that we must scale differently if we don't want the holonomy to blow up in the limit. With the scaling $\frac{1}{K}$ instead of $\frac{1}{\sqrt{K}}$, we end up with a non-trivial and explicit limit.

In a work in progress, we show that it is possible to define a similar model with the Abelian group $U(1)$ replaced with a non-Abelian one, and that holonomy along a planar Brownian motion still has a non-trivial limit, on the same scaling.

This seems to be related with the question treated in [1], in which the holonomy along the Brownian bridge is averaged on $U(1)$ (seen as a subset of \mathbb{C}), and then looked in the almost sure sense in the Yang-Mills field. Under a different normalization procedure, a limit in L^p is shown to exist (but not made explicit). Nonetheless, the normalization procedure and the tools involved are so radically different than ours that it is hard to be sure the two things are even remotely related.

Part II

Liouville area enclosed by curves

Chapter 5

Lévy area for the Liouville measure: existence

We extend some of the results of the previous chapters to the case when the Lebesgue measure is replaced with a Gaussian multiplicative chaos whose intermittency parameter γ is small enough.

5.1 Introduction

In this chapter and the next one, \mathbf{M} will be a random measure, which is heuristically described by the formula

$$\forall A \in \mathcal{B}(\mathbb{R}^2), \quad \mathbf{M}(A) = \int_A \exp(\gamma \Phi_z - \frac{\gamma^2}{2} \mathbb{E}[\Phi_z^2]) \, d\lambda(z), \quad (5.1)$$

where Φ is a centered Gaussian field, and $\gamma \in [0, 2)$. It is assumed that the covariance kernel $K : \mathbb{R}^2 \times \mathbb{R}^2 \rightarrow \mathbb{R}_+ \cup \{\infty\}$ of Φ takes the form

$$K(z, w) = \log_+(|z - w|^{-1}) + g(z, w),$$

where \log_+ is the positive part of the logarithm and $g : \mathbb{R}^2 \times \mathbb{R}^2 \rightarrow \mathbb{R}$ is a bounded and \mathcal{C}^2 -function with bounded derivatives up to order 2.

The kernel K is well defined, as well as the random field Φ , even though the logarithmic divergence of K makes Φ a random distribution rather than a random function. However, precisely because Φ is a random distribution, (5.1) does not make sense, and the construction of \mathbf{M} cannot rely on this formula. The first construction of a random measure that is a reasonable candidate to be a mathematical incarnation of (5.1) was given using the theory of multiplicative chaos by Kahane [29]. For an introduction to Gaussian multiplicative chaos, see also [40] and [5]. In general, the larger γ , the more irregular the measure. Most of the time in this paper, we will be working in the case where $\gamma < \sqrt{2}$. We will thus be in the so-called ‘ L^2 -phase’, in which it is relatively easy to define and to study \mathbf{M} , using martingale methods and Hilbertian techniques.

We will denote by $(\Omega^{\mathbf{M}}, \mathcal{F}^{\mathbf{M}}, \mathbb{P}^{\mathbf{M}})$ the probability space on which \mathbf{M} is defined. We also let $(\Omega^X, \mathcal{F}^X, \mathbb{P}^X)$ be a second probability space, on which a planar Brownian motion $X = (X_t)_{t \in [0,1]}$ is defined. Finally, we denote by $(\Omega, \mathcal{F}, \mathbb{P})$ the product probability space.

This chapter is devoted to the proof of the following result.

Theorem 1. *Assume $\gamma < \sqrt{4/3}$. Then, \mathbb{P} -almost surely, the integral*

$$\int_{\mathbb{R}^2} [\theta(z)]_K \, d\mathbf{M}(z)$$

admits a limit \mathbb{A}^X as $K \rightarrow +\infty$.

*Moreover, for all $p \in [2, \frac{4}{\gamma^2})$, this limit lies in $L^p(\Omega^X, L^2(\Omega^{\mathbf{M}}))$.*¹

The computations that we made for the Lebesgue measure remains valid here: for all integer K ,

$$\int_{\mathbb{R}^2} [\theta(z)]_K \, d\mathbf{M}(z) = \sum_{N=1}^K (\mathbf{M}(\mathcal{D}_N) - \mathbf{M}(\mathcal{D}_{-N})).$$

In particular, Theorem 1 follows directly from the next proposition. For a random variable $X : \Omega \rightarrow \mathbb{R}$, we denote by $\|X\|_{p,2}$ the norm

$$\|X\|_{p,2} = \mathbb{E}^X [\mathbb{E}^{\mathbf{M}} [X^2]^{\frac{p}{2}}]^{\frac{1}{p}}.$$

Proposition 2. *For all $p \in [2, \frac{4}{\gamma^2})$, there exists $\varepsilon > 0$ and C such that for all N ,*

$$\|\mathbf{M}(\mathcal{D}_N) - \mathbf{M}(\mathcal{D}_{-N})\|_{p,2} \leq CN^{-1-\varepsilon}.$$

The strategy for the proof of Proposition 2 is similar to the proof that the L^p -norm of $D_N - \frac{1}{2\pi N}$ is small. However, some additional difficulties arise. Indeed, we have no asymptotic equivalent for the norm of $\mathbf{M}(\mathcal{D}_N)$, but only an upper bound. This explains why we take a symmetric summation instead of subtracting a deterministic sequence. Besides, without this first order asymptotic, we do not have the large deviation estimate that allowed us to obtain the second order bound in L^p from the second order bound in L^2 . Here, we are directly proving the bound in $L^p(\Omega^X, L^2(\Omega^{\mathbf{M}}))$.

The case $p = 2$ admits a drastic simplification, which is the following. Let us recall from the first chapter that our bootstrap consist on replacing $\mathbf{M}(\mathcal{D}_N) - \mathbf{M}(\mathcal{D}_{-N})$ with

$$\mathbf{M}_N = \sum_{i=1}^T (\mathbf{M}(\mathcal{D}_N^i) - \mathbf{M}(\mathcal{D}_{-N}^i)). \quad (5.2)$$

The $L^p(\Omega^X, L^2(\Omega^{\mathbf{M}}))$ -norm of the latter quantity can be written

$$\mathbb{E}^X \left[\left| \sum_{i,j=1}^T \mathbb{E}^{\mathbf{M}} [(\mathbf{M}(\mathcal{D}_N^i) - \mathbf{M}(\mathcal{D}_{-N}^i))(\mathbf{M}(\mathcal{D}_N^j) - \mathbf{M}(\mathcal{D}_{-N}^j))] \right|^{\frac{p}{2}} \right]^{\frac{1}{p}}.$$

¹The reader may find surprising, as we do, that the integrability with respect to \mathbb{P}^X depends on γ , and not the integrability with respect to $\mathbb{P}^{\mathbf{M}}$. However, the result as it is written is what we mean.

When $p = 2$, the absolute can be omitted, and the sums can be swapped with the expectation under \mathbb{P}^X . Then, what happens is that the all the non-diagonal terms (that is, the ones with $i \neq j$) vanishes by symmetry. Indeed,

$$\begin{aligned} & \mathbb{E}[(\mathbf{M}(\mathcal{D}_N^i) - \mathbf{M}(\mathcal{D}_{-N}^i))(\mathbf{M}(\mathcal{D}_N^j) - \mathbf{M}(\mathcal{D}_{-N}^j))] \\ &= \mathbb{E}^{\mathbf{M}} \left[\mathbb{E}^X \left[\int_{\mathbb{R}^2} (\mathbb{1}_{z \in \mathcal{D}_N^i} - \mathbb{1}_{z \in \mathcal{D}_{-N}^i}) (\mathbb{P}^X(z \in \mathcal{D}_N^j | (X_t)_{t \leq iT-1}) - \mathbb{P}^X(z \in \mathcal{D}_{-N}^j | (X_t)_{t \leq iT-1})) \, d\mathbf{M}(z) \right] \right]. \end{aligned}$$

The two probabilities on the right-hand side are equal, and the wwhole thing vanishes.

Here, we should mention that this argument is very specific to the Brownian motion, and that the control we use to replace this argument when $p \neq 2$ is also shaped to extend to other situations.

In Section 5.3, we will prove the following bound.

Proposition (5.3.7). *Let $p \in (1, +\infty)$ and $\varepsilon > 0$. Then, for t small enough, there exists C such that for all $N \geq 1$,*

$$\|\mathbf{M}(\mathcal{D}_N) - \mathbf{M}_N\|_{p,2} \leq CN^{-\frac{3\nu}{4} + 2t + \varepsilon}.$$

In Section 5.4, we will prove the following bound that replace the symmetry argument given above.

Lemma (5.4.2). *For $t, \varepsilon > 0$, and $i, j \in \{1, \dots, T\}$, let $F_{i,j} = \{|X_{(i+1)T-1} - X_{jT-1}| \geq T^{-\frac{1}{2} + \varepsilon}\}$. For all $p \in [2, \frac{4}{\gamma^2})$, there exists a constant C such that for all $N \geq 1$,*

$$\begin{aligned} & \mathbb{E}^X \left[\left| \mathbb{E}^{\mathbf{M}} \left[\sum_{i,j=1}^T \mathbb{1}_{F_{i,j}} (\mathbf{M}(\mathcal{D}_N^i) - \mathbf{M}(\mathcal{D}_{-N}^i)) (\mathbf{M}(\mathcal{D}_N^j) - \mathbf{M}(\mathcal{D}_{-N}^j)) \right] \right|^{\frac{p}{2}} \right]^{\frac{1}{p}} \\ & \leq C \log(N+1)^{\frac{1}{p}} T^{\frac{\varepsilon}{2}} N^{-1} (N^{-\frac{1}{4} + o(1)} + T^{\frac{\gamma^2}{4} - \frac{1}{p}}). \end{aligned} \quad (5.3)$$

The bootstrap then takes the following form. In the statement, there appears a set $\mathcal{T}(\mathbf{M})$ of random measures that will be defined precisely in Section 5.2. For the moment, suffice it to say that all the elements of $\mathcal{T}(\mathbf{M})$ look like \mathbf{M} , in the sense that they are deduced from \mathbf{M} by (possibly random) translations and symmetries. In many cases of interest, namely when g is invariant by translation, $\mathcal{O}(\mathbf{M}) = \{\mathbf{M}\}$.

Lemma (5.5.1). *Consider $t > 0, p \in [2, \frac{4}{\nu}]$ and $\zeta \in \mathbb{R}$. Assume that there exists a constant C such that for all $\mathbf{M}' \in \mathcal{T}(\mathbf{M})$ and all $N \geq 1$,*

$$\|\mathbf{M}'(\mathcal{D}_N) - \mathbf{M}'(\mathcal{D}_{-N})\|_{p,2} \leq CN^\zeta.$$

Then, for all $\varepsilon > 0$, there exists a constant C' such that for all $N \geq 1$,

$$\mathbb{E}^X \left[\mathbb{E}^{\mathbf{M}} \left[\sum_{1 \leq i \leq j \leq T} \mathbb{1}_{F_{i,j}^c} |(\mathbf{M}(\mathcal{D}_N^i) - \mathbf{M}(\mathcal{D}_{-N}^i)) (\mathbf{M}(\mathcal{D}_N^j) - \mathbf{M}(\mathcal{D}_{-N}^j))|^{\frac{p}{2}} \right]^{\frac{1}{p}} \right] \leq C' \log(T+1)^{\frac{1}{p}} T^{\frac{\gamma^2}{4} - \frac{1}{p} + \varepsilon} N^\zeta.$$

These propositions, properly combined, will allow us to prove Proposition 2.

5.2 Three estimates about the Liouville measures

In this section, we assume that $\gamma < \sqrt{2}$. Recall that ν is the positive real number

$$\nu = 2 - \frac{\gamma^2}{2}.$$

One of the advantages of working in the L^2 -phase (that is, under the assumption $\gamma < \sqrt{2}$) is that one has the following explicit formula.

Lemma 5.2.1. *Let A, B be two Borel subsets of \mathbb{R}^2 with finite Lebesgue measure. Then,*

$$\mathbb{E}^{\mathbf{M}}[\mathbf{M}(A)\mathbf{M}(B)] = \int_{A \times B} \exp(\gamma^2 K(z, w)) \, dz \, dw.$$

Proof. We first do an informal computation, which is entirely valid when the kernel K is replaced with a continuous kernel \tilde{K} (in which case the centered Gaussian field ϕ with kernel \tilde{K} is defined pointwise):

$$\begin{aligned} \mathbb{E}^{\mathbf{M}}[\mathbf{M}(A)\mathbf{M}(B)] &= \mathbb{E}^{\mathbf{M}} \left[\int_{A \times B} e^{\gamma\phi_z - \frac{\gamma^2}{2}\mathbb{E}^{\mathbf{M}}[\phi_z^2]} e^{\gamma\phi_w - \frac{\gamma^2}{2}\mathbb{E}^{\mathbf{M}}[\phi_w^2]} \, dz \, dw \right] \\ &= \int_{A \times B} \mathbb{E}^{\mathbf{M}} \left[e^{\gamma(\phi_z + \phi_w) - \frac{\gamma^2}{2}\mathbb{E}^{\mathbf{M}}[(\phi_z + \phi_w)^2]} \right] e^{\gamma^2 \tilde{K}(z, w)} \, dz \, dw \\ &= \int_{A \times B} e^{\gamma^2 \tilde{K}(z, w)} \, dz \, dw. \end{aligned}$$

For a smooth mollifier θ and a centered Gaussian field Φ with kernel K , we define θ_ε as the function $\varepsilon^{-2}\theta(\frac{\cdot}{\varepsilon})$, and Φ_ε as the convolution of Φ with θ_ε . For a Borel measurable set A with finite Lebesgue measure, set also

$$\mathbf{M}_\varepsilon(A) = \int_A e^{\gamma\Phi_\varepsilon(z) - \frac{\gamma^2}{2}\mathbb{E}[(\Phi_\varepsilon(z))^2]} \, d\lambda(z).$$

Then, when $\varepsilon \rightarrow 0$, $\mathbf{M}_\varepsilon(A)$ converges in L^2 toward $\mathbf{M}(A)$ (see for example [41, Theorem 2.3]²).

It follows that for any two Lebesgue measurable sets A and B with finite Lebesgue measures,

$$\mathbb{E}^{\mathbf{M}}[\mathbf{M}(A)\mathbf{M}(B)] = \lim_{\varepsilon \rightarrow 0} \mathbb{E}^{\mathbf{M}}[\mathbf{M}_\varepsilon(A)\mathbf{M}_\varepsilon(B)].$$

On the other hand, the previous computation shows that

$$\begin{aligned} \mathbb{E}^{\mathbf{M}}[\mathbf{M}_\varepsilon(A)\mathbf{M}_\varepsilon(B)] &= \int_{A \times B} e^{\gamma^2 \mathbb{E}^{\mathbf{M}}[X_\varepsilon(z)X_\varepsilon(w)]} \, dz \, dw \\ &\xrightarrow{\varepsilon \rightarrow 0} \int_{A \times B} e^{\gamma^2 K(z, w)} \, dz \, dw. \end{aligned}$$

The last convergence follows from pointwise convergence of $\mathbb{E}[X_\varepsilon(z)X_\varepsilon(w)]$ toward $K(z, w)$, and dominated convergence theorem (see [41, Theorem 2.3] again). \square

²The cited theorem states convergence in probability, without assuming $\gamma < \sqrt{2}$, but the proof is about the L^2 convergence provided $\gamma < \sqrt{2}$. Remark that it is taken as a definition for the measure \mathbf{M} (up to some argument to make it not only a collection of random variables, but a measure). The original construction of Kahane is rather different.

According to [40] (for example), the scaling properties of the measure \mathbb{M} are such that, in the case where $K(z, w) = \log_+(|z + w|^{-1})$, for a set $A \subset B(0, \frac{1}{2})$ and $r < 1$, we have

$$\mathbb{E}^{\mathbb{M}}[\mathbb{M}(rA)^2] = r^{2\nu} \mathbb{E}^{\mathbb{M}}[\mathbb{M}(A)^2],$$

where ν is the constant defined at the beginning of this section. We deduce that for each such set A , there exists a constant C such that for all $r \leq 1$,

$$\mathbb{E}^{\mathbb{M}}[\mathbb{M}(rA)^2] \leq C|rA|^\nu.$$

We can actually choose C such that the two terms are equal. The following lemma states that the constant C can be chosen to be uniform over all measurable sets A .

Lemma 5.2.2. *There exists C such that for all measurable set $A \subset \mathbb{R}^2$,*

$$\mathbb{E}^{\mathbb{M}}[\mathbb{M}(A)^2] \leq C(|A|^\nu + |A|^2).$$

Proof. From the previous lemma, we know that

$$\mathbb{E}^{\mathbb{M}}[\mathbb{M}(A)^2] = \int_{A^2} \exp(\gamma^2 K(z, w)) \, dz \, dw.$$

Since $K(z, w) \leq \log_+(|z - w|^{-1}) + c$ for some constant c ,

$$\mathbb{E}^{\mathbb{M}}[\mathbb{M}(A)^2] \leq e^{\gamma^2 c} \int_{A^2} \exp(\gamma^2 \log_+(|z - w|^{-1})) \, dz \, dw = e^{\gamma^2 c} \int_{A^2} \max(|z - w|^{-\gamma^2}, 1) \, dz \, dw.$$

Let $r = |A|^{\frac{1}{2}} \pi^{-\frac{1}{2}}$ be the radius of a disk of the same area as A , and

$$S_r = \sup_{A': |A'| = \pi r^2} \int_{A'} \max(|z|^{-\gamma^2}, 1) \, dz.$$

The supremum is achieved by the ball $B(0, r)$. By considering separately the cases $r \leq 1$ and $r \geq 1$, we find that $S_r \leq \frac{2\pi}{2-\gamma^2} r^{2-\gamma^2} + \pi r^2$.

By invariance under translations, S_r is also equal to

$$\sup_{w \in \mathbb{R}^2} \sup_{A': |A'| = \pi r^2} \int_{A'} \max(|z - w|^{-\gamma^2}, 1) \, dz.$$

Thus,

$$\begin{aligned} \mathbb{E}^{\mathbb{M}}[\mathbb{M}(A)^2] &\leq e^{\gamma^2 c} \int_{A^2} \max(|z - w|^{-\gamma^2}, 1) \, dz \, dw \\ &\leq e^{\gamma^2 c} |A| S_r \leq e^{\gamma^2 c} \left(\frac{2\pi}{2-\gamma^2} |A|^{2-\frac{\gamma^2}{2}} + |A|^2 \right). \end{aligned}$$

This concludes the proof. \square

The next estimate, should be understood as a quantitative version of the following idea. Let first A_1 , A_2 and B be three sets such that A_1 and A_2 are very close from each other, have comparable Lebesgue measures, and are far from B ; then, $\mathbb{E}^M[M(A_1)M(B)]$ should be very close to $\mathbb{E}^M[M(A_2)M(B)]$. Let now A_1 , A_2 , B_1 , and B_2 be four sets such that

- ◊ A_1 and A_2 are very close from each other, and have comparable Lebesgue measures,
- ◊ B_1 and B_2 are very close from each other, and have comparable Lebesgue measures,
- ◊ The A_i are far from the B_i .

Then, the expectation $\mathbb{E}^M[(M(A_2) - M(A_1))(M(B_2) - M(B_1))]$ should be even smaller than $\mathbb{E}^M[(M(A_2) - M(A_1))M(B_i)]$. Remark that the control on the ‘four terms’ expectation should depend on the distance between the A_i , the distance between the B_i , the distance between A_i and B_i , the Lebesgue measure of these four sets, and finally the difference between their Lebesgue measure. Hence, we do not expect a very short bound to appear.

For two disjoint sets A and B , let us define

$$\begin{aligned} d_{\text{sup}}(A, B) &= \sup\{d(z, z') : z \in A, z' \in B\}, \\ d_{\text{inf}}(A, B) &= \min(\inf\{d(z, z') : z \in A, z' \in B\}, 1), \end{aligned}$$

as illustrated by Figure 5.1 below.

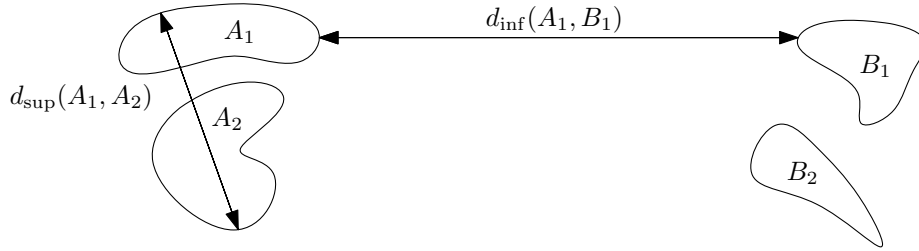

Figure 5.1: A typical position for the sets in Lemma 5.2.3, and some of the ‘distances’ between them. A typical choice for these sets would be $A_1 = \mathcal{D}_N^i$, $A_2 = \mathcal{D}_{-N}^i$, $B_1 = \mathcal{D}_N^j$, and $B_2 = \mathcal{D}_{-N}^j$.

Lemma 5.2.3. *There exists C such that for all bounded Borel measurable sets A_1, A_2, B_1, B_2 with $4 \max(d_{\text{sup}}(A_1, A_2), d_{\text{sup}}(B_1, B_2)) \leq d_{\text{inf}}(A_1, B_1)$ and $|A_1|, |A_2|, |B_1|, |B_2| \leq 1$,*

$$\begin{aligned} |\mathbb{E}^M[(M(A_1) - M(A_2))(M(B_1) - M(B_2)))]| &\leq C \left(d_{\text{inf}}(A_1, B_1)^{-\gamma^2} ||B_1| - |B_2|| |A_1| - |A_2| \right) \\ &\quad + (d_{\text{sup}}(A_1, A_2) + d_{\text{sup}}(B_1, B_2)) d_{\text{inf}}(A_1, B_1)^{-1-\gamma^2} (|A_1| ||B_1| - |B_2|| + ||A_2| - |A_1|| |B_1|) \\ &\quad + d_{\text{inf}}(A_1, B_1)^{-2-\gamma^2} d_{\text{sup}}(A_1, A_2) d_{\text{sup}}(B_1, B_2) |A_1| |B_1|. \end{aligned} \quad (5.4)$$

Let us remark that the exponent γ , which is carried by $|A|$ when looking at $\mathbb{E}^M[M(A)^2]$, is here carried instead by $d_{\text{inf}}(A_1, B_1)$. Remark also that all these terms but the last vanish if $|A_1| = |A_2|$ and $|B_1| = |B_2|$.

Proof. It is a simple computation. Using the explicit formula given by Lemma 5.2.1, we have

$$\begin{aligned} \mathbb{E}^{\mathbb{M}}[(\mathbb{M}(A_1) - \mathbb{M}(A_2))(\mathbb{M}(B_1) - \mathbb{M}(B_2))] &= \int_{A_1 \times B_1} e^{\gamma K(z_1, w_1)} dz_1 dw_1 - \int_{A_1 \times B_2} e^{\gamma K(z_1, w_2)} dz_1 dw_2 \\ &\quad - \int_{A_2 \times B_1} e^{\gamma K(z_2, w_1)} dz_2 dw_1 + \int_{A_2 \times B_2} e^{\gamma K(z_2, w_2)} dz_2 dw_2 \end{aligned}$$

Writing $Q = A_1 \times A_2 \times B_1 \times B_2$, the right-hand side of this equation is equal to

$$\begin{aligned} \frac{1}{|Q|} \int_Q &\left(|A_1| |B_1| (e^{\gamma K(z_1, w_1)} - e^{\gamma K(z_1, w_2)} - e^{\gamma K(z_2, w_1)} + e^{\gamma K(z_2, w_2)}) \right. \\ &\quad + |A_1| (|B_2| - |B_1|) (e^{\gamma K(z_2, w_2)} - e^{\gamma K(z_1, w_2)}) + (|A_2| - |A_1|) |B_1| (e^{\gamma K(z_2, w_2)} - e^{\gamma K(z_2, w_1)}) \\ &\quad \left. + (|A_2| - |A_1|) (|B_2| - |B_1|) e^{\gamma K(z_2, w_2)} \right) dz_1 dz_2 dw_1 dw_2. \end{aligned}$$

This, in absolute value, is less than

$$\begin{aligned} &\sup_{(z_1, z_2, w_1, w_2) \in Q} \left(|A_1| |B_1| |e^{\gamma K(z_1, w_1)} - e^{\gamma K(z_1, w_2)} - e^{\gamma K(z_2, w_1)} + e^{\gamma K(z_2, w_2)}| \right. \\ &\quad + |A_1| \left| |B_2| - |B_1| \right| |e^{\gamma K(z_2, w_2)} - e^{\gamma K(z_1, w_2)}| + \left| |A_2| - |A_1| \right| |B_1| |e^{\gamma K(z_2, w_2)} - e^{\gamma K(z_2, w_1)}| \\ &\quad \left. + \left| |A_2| - |A_1| \right| \left| |B_2| - |B_1| \right| e^{\gamma K(z_2, w_2)} \right). \end{aligned}$$

We set D_A a ball of diameter $d_{\sup}(A_1, A_2)$ containing A_1 and A_2 , and D_B a ball of diameter $d_{\sup}(B_1, B_2)$ containing B_1 and B_2 , so that the last expression is less than

$$\begin{aligned} &|A_1| |B_1| d_{\sup}(A_1, A_2) d_{\sup}(B_1, B_2) \sup_{z \in D_A, w \in D_B} \|\nabla^2 e^{\gamma K(z, w)}\| \\ &\quad + |A_1| \left| |B_2| - |B_1| \right| d_{\sup}(A_1, A_2) \sup_{z \in D_A, w_2 \in B_2} \|\nabla e^{\gamma K(z, w_2)}\| \\ &\quad + \left| |A_2| - |A_1| \right| |B_1| d_{\sup}(B_1, B_2) \sup_{z_2 \in A_2, w \in D_B} \|\nabla e^{\gamma K(z_2, w)}\| \\ &\quad + \left| |A_2| - |A_1| \right| \left| |B_2| - |B_1| \right| \sup_{z_2 \in A_2, w_2 \in B_2} e^{\gamma K(z_2, w_2)}. \end{aligned}$$

The three suprema appearing in this expression are respectively less than $C d_{\inf}(D_A, D_B)^{-2-\gamma^2}$, $C d_{\inf}(D_A, B_2)^{-1-\gamma^2}$ and $C d_{\inf}(A_2, B_2)^{-\gamma^2}$, where the constant C depends on the exact expression of the kernel K but not on the four sets A_1, A_2, B_1, B_2 .

Since $d_{\inf}(D_A, D_B) \geq d_{\inf}(A_1, B_1) - d_{\sup}(A_1, A_2) - d_{\sup}(B_1, B_2) \geq \frac{1}{2} d_{\inf}(A_1, B_1)$, we deduce the announced inequality. \square

For reasons that will appear only at the end of the proof, we need to consider not only the random measure \mathbb{M} , but also measures obtained by possibly random (but independent from \mathbb{M}) translation of \mathbb{M} .

For $z \in \mathbb{R}^2$, we define the random measure $\tau_z(\mathbf{M})$ by setting, for all Borel measurable set A ,

$$\tau_z(\mathbf{M})(A) = \mathbf{M}(A + z).$$

For a probability law p on \mathbb{R}^2 , we also set $\tau_p(\mathbf{M}) = \int_{\mathbb{R}^2} \tau_z(\mathbf{M}) dp(z)$. Finally, we define

$$\mathcal{T}(\mathbf{M}) = \{\tau_p(\mathbf{M}) : p \text{ is a probability law on } \mathbb{R}^2\}.$$

For a random measure $\tilde{\mathbf{M}}$, let us define

$$\begin{aligned} \|\tilde{\mathbf{M}}\|_0 &= \inf \{C > 0 : \forall A \text{ Borel set with } |A| \leq 1, \mathbb{E}^{\tilde{\mathbf{M}}}[\tilde{\mathbf{M}}(A)^2] \leq C|A|^\nu\}^{\frac{1}{2}} \\ &= \inf \{C > 0 : \text{Lemma 5.2.2 holds}\}^{\frac{1}{2}} \end{aligned}$$

and, similarly³,

$$\|\tilde{\mathbf{M}}\|_2 = \inf \{C > 0 : \text{Lemma 5.2.3 holds}\}^{\frac{1}{2}}.$$

It is easily shown that, for all $\tilde{\mathbf{M}} \in \mathcal{T}(\mathbf{M})$, $\|\tilde{\mathbf{M}}\|_0 \leq \|\mathbf{M}\|_0$ and $\|\tilde{\mathbf{M}}\|_2 \leq \|\mathbf{M}\|_2$.

In the following two sections, all the results stated with \mathbf{M} also hold for any measure $\tilde{\mathbf{M}} \in \mathcal{T}(\mathbf{M})$, with the same constants. Actually, they hold for all random measure $\tilde{\mathbf{M}}$ with $\|\tilde{\mathbf{M}}\|_0 < +\infty$ and $\|\tilde{\mathbf{M}}\|_2 < +\infty$. Furthermore, they hold uniformly on $\mathcal{T}(\mathbf{M})$ provided the constants C are replaced with $C(\|\tilde{\mathbf{M}}\|_0 + \|\tilde{\mathbf{M}}\|_2)$.

5.3 Comparison of $\mathbf{M}(\mathcal{D}_N)$ and \mathbf{M}_N

Let us recall some notations we used through the thesis. We fix $t > 0$, a small positive real. We also fix a (large) positive integer N , and define $T = \lfloor N^t \rfloor$. In the estimations that follow, t is going to be fixed, and N is going to tend to infinity.

For each $i \in \{1, \dots, T\}$, we define

- ◊ X^i to be the restriction of X to $[(i-1)T^{-1}, iT^{-1}]$,
- ◊ \bar{X}^i the concatenation of X^i with the segment between its endpoints and \bar{X} the concatenation of X with the segment between its endpoints,
- ◊ \mathcal{E} the union of the range of \bar{X} and the T segments joining the endpoints of X^i , $i \in \{1, \dots, T\}$
- ◊ For $z \in \mathbb{R}^2 \setminus \mathcal{E}$, $\theta^i(z)$ the number of times \bar{X}^i winds around z ,
- ◊ For an integer N and an index $i \in \{1, \dots, T\}$,

$$\mathcal{D}_N^i = \{z \in \mathbb{R}^2 \setminus \mathcal{E} : \theta^i(z) \geq N\},$$

- ◊ For two integers N, M_1 and two indices $i, j \in \{1, \dots, T\}$,

$$\mathcal{D}_{N, M_1}^{i, j} = \{z \in \mathbb{R}^2 \setminus \mathcal{E} : |\theta^i(z)| \geq N, |\theta^j(z)| \geq M_1\},$$

³We chose this notation because it is related to the second derivatives of the kernel K .

- ◊ For two integers N, M_2 and a multi-index $\mathbf{i} \in \mathbf{I}_k = \{(i_1, \dots, i_k) \in \{1, \dots, T\}^k : i_1 < \dots < i_k\}$,

$$\mathcal{D}_{M_2}^{\mathbf{i}} = \{z \in \mathbb{R}^2 \setminus \mathcal{E} : \forall l \in \{1, \dots, k\}, |\theta^{i_l}(z)| \geq M_2\}.$$

In this last definition, the integer k that we will use only depend on the intermittency parameter γ , and can be thought of as being fixed.

We have also define

$$M_N = \sum_{i=1}^T M(\mathcal{D}_N^i).$$

Let us stress the fact that the law of the random sets \mathcal{D}_N^i can be deduced from that of \mathcal{D}_N by a scaling and a random translation. This self-similar behaviour will come into play in a crucial way in Section 5.5.

As we already explained, one of our main objects of interest is $M(\mathcal{D}_N)$, the M -measure of the set of points around which the Brownian motion winds at least N times, and our strategy to study it is to compare it with M_N .

The goal of this section is to prove that $M(\mathcal{D}_N)$ and M_N are close, in the sense of Proposition 5.3.7. This result will allow us, in Section 5.5, to transfer to $M(\mathcal{D}_N)$ the information about M_N that we will gather in Section 5.4. The following lemma is a slight improvement from Lemma 2.18 (which corresponds to the case $k = 3$).

Lemma 5.3.1. *Assume that $TM_2 \leq \frac{N}{k} - T$ and $kM_1 + (M_2 + 1)T < N$. Then,*

$$\bigcup_{i=1}^T \mathcal{D}_{N+TM_1}^i \setminus \bigcup_{i \neq j} \mathcal{D}_{\frac{N}{k}, M_1}^{i,j} \subseteq \mathcal{D}_N \setminus \mathcal{E} \subseteq \bigcup_{i=1}^T \mathcal{D}_{N-kM_1-(M_2+1)T}^i \cup \bigcup_{i \neq j} \mathcal{D}_{\frac{N}{k}, M_1}^{i,j} \cup \bigcup_{\mathbf{i} \in \mathbf{I}_k} \mathcal{D}_{M_2}^{\mathbf{i}}.$$

These inclusions are purely deterministic and the statement remains true if replace the Brownian curve with any other curve. The proof is based on a discussion of the highest values taken by the winding functions of the pieces of our curve. It would probably be best done by the reader for himself, but we offer a detailed argument for the second inclusion, which is the less simple one.

Proof. For a given point $z \in \mathbb{R}^2 \setminus \mathcal{E}$, let us sort the values $(|\theta^i(z)|)_{i \in \{1, \dots, T\}}$ in non-increasing order and denote them by $\eta_1 \geq \dots \geq \eta_T$. Let us also denote $\tilde{\eta}_1$ one of the values $(\theta^i(z))_{i \in \{1, \dots, T\}}$ such that $|\tilde{\eta}_1| = \eta_1$. We have the following implications:

$$\begin{aligned} z \notin \bigcup_{i=1}^T \mathcal{D}_{N-kM_1-(M_2+1)T}^i &\implies \tilde{\eta}_1 < N - kM_1 - (M_2 + 1)T, \\ z \notin \bigcup_{\mathbf{i} \in \mathbf{I}_k} \mathcal{D}_{M_2}^{\mathbf{i}} &\implies \eta_k < M_2, \\ z \notin \bigcup_{i \neq j} \mathcal{D}_{\frac{N}{k}, M_1}^{i,j} &\implies (\eta_1 < \frac{N}{k} \text{ or } \eta_2 < M_1). \end{aligned}$$

If z is in none of the sets appearing on the left of these implications, we are in one of two cases, depending on which of the two assertions on the right of the third implication holds.

If $\eta_1 < \frac{N}{k}$, then $\eta_2, \dots, \eta_{k-1} < \frac{N}{k}$ and

$$\sum_{i=1}^T \theta^i(z) \leq \sum_{i=1}^T \eta_i < (k-1) \frac{N}{k} + (T - (k-1))M_2 \leq N - T.$$

If $\eta_2 < M_1$, then $\eta_3, \dots, \eta_{k-1} < M_1$ and

$$\sum_{i=1}^T \theta^i(z) \leq \tilde{\eta}_1 + \sum_{i=2}^T \eta_i < (N - kM_1 - (M_2 + 1)T) + (k-2)M_1 + (T - (k-1))M_2 \leq N - T.$$

In both cases, we conclude that $\sum_{i=1}^T \theta^i(z) \leq N - T$. The difference between this sum and $\theta_X(z)$ is the winding at z of a piecewise linear curve with $T+1$ pieces, which cannot exceed $T-1$. Thus $\theta_X(z) < N$, so that $z \notin \mathcal{D}_N$. \square

In order to compare $M(\mathcal{D}_N)$ with M_N , we are going to take the M -measures of the sets of which we just proved the inclusion. The M -measures of the first unions appearing in the leftmost and rightmost terms of Lemma 5.3.1 will be close, but not exactly equal, to M_N .

A first difference is that we are taking the measure of a union instead of the sum of the measures. This problem turns out not to be a serious one, and will be treated in the proof of Proposition 5.3.7.

A second difference is that instead of M_N , there seems to appear $M_{N'}$ for two integers N' close to N . To go around this difficulty, we will in fact apply Lemma 5.3.1 to several well-chosen values of N , and use Lemma 5.3.4 to connect the various estimations that we obtain in this way.

A third difference is that there are correction terms appearing on both sides, and which we need to control: this will be done by the following Lemma 5.3.2 and Corollary 5.3.3.

The first estimation in the next statement is a mild reformulation of the Lemma 2.4 that we obtained in [43]. The second one is a slight improvement of the Lemma 2.5 in the same paper, which corresponds to the case $k=3$. The extension from $k=3$ to general k is obtain by following the same proof. It is a long, but elementary, computation that involves a decomposition of $(\mathbb{R}^2)^{k-1}$ into a family of products of balls and complementary of balls in \mathbb{R}^2 .

Lemma 5.3.2. *For all positive integer k and all $r \in (0, +\infty)$, there exists C such that for all positive integers N, M_1, M_2 and T , the following holds.*

\diamond For all $i, j \in \{1, \dots, T\}, i \neq j$,

$$\mathbb{E}^X [|\mathcal{D}_{N, M_1}^{i, j}|^r] \leq C \log(TNM_1 + 1)^{3r+1} \frac{(TNM_1)^{-r}}{|j-i|+1}.$$

\diamond For all $\mathbf{i} \in \mathbf{I}_k$,

$$\mathbb{E}^X [|\mathcal{D}_{M_2}^{\mathbf{i}}|^r] \leq C \log(M_2T + 1)^{(k+1)(r+1)-2} \frac{T^{-r} M_2^{-kr}}{\prod_{j=1}^{k-1} (i_{j+1} - i_j + 1)}.$$

From these estimations, Lemma 5.2.2 allows us to deduce corresponding estimations in the Liouville case. We then sum over $i \neq j$ or over \mathbf{i} , and we obtain the following result.

Corollary 5.3.3. *For all positive integer k , for all $p \in [1, +\infty)$, there exists a constant C such that for all positive integers N, M_1, M_2, T ,*

$$\begin{aligned} \sum_{i \neq j} \|M(\mathcal{D}_{N, M_1}^{i,j})\|_{p,2} &\leq C \log(TNM_1 + 1)^{\frac{3\nu}{2} + \frac{1}{p}} T^{2 - \frac{1}{p} - \frac{\nu}{2}} N^{-\frac{\nu}{2}} M_1^{-\frac{\nu}{2}}, \\ \sum_{i \in \mathbf{I}_k} \|M(\mathcal{D}_{M_2}^i)\|_{p,2} &\leq C \log(M_2T + 1)^{(k+1)(\frac{\nu}{2} + \frac{1}{p}) - 2} T^{k - \frac{k}{p} - \frac{\nu}{2}} M_2^{-k\frac{\nu}{2}}. \end{aligned}$$

Proof. We prove the first inequality, the second proof is identical. For $i \neq j$, by Lemma 5.2.2,

$$\mathbb{E}^M [M(\mathcal{D}_{N, M_1}^{i,j})^2]^{\frac{1}{2}} \leq C (|\mathcal{D}_{N, M_1}^{i,j}|^{\frac{\nu}{2}} + |\mathcal{D}_{N, M_1}^{j,i}|).$$

Applying Lemma 5.3.2 with $r = \frac{p\nu}{2}$ and with $r = p$, we obtain

$$\begin{aligned} \mathbb{E}^X [\mathbb{E}^M [M(\mathcal{D}_{N, M_1}^{i,j})^2]^{\frac{p}{2}}]^{\frac{1}{p}} &\leq C' \mathbb{E}^X [|\mathcal{D}_{N, M_1}^{i,j}|^{\frac{p\nu}{2}} + |\mathcal{D}_{N, M_1}^{j,i}|^p]^{\frac{1}{p}} \\ &\leq C'' \log(TNM_1 + 1)^{\frac{3\nu}{2} + \frac{1}{p}} \frac{(TNM_1)^{-\frac{\nu}{2}}}{(|j-i|+1)^{\frac{1}{p}}}. \end{aligned}$$

We then sum over $i \neq j$ to get the announced bound. \square

The next lemma compares the measures of \mathcal{D}_N and $\mathcal{D}_{N'}$ when N and N' are close.

Lemma 5.3.4. *Let $M = M(N)$ be an integer-valued function of N such that $M \rightarrow \infty$ and $\frac{M}{N} \rightarrow 0$ as N tends to infinity. Then, for all $r \in (0, +\infty)$,*

$$\mathbb{E}^X [||\mathcal{D}_N| - |\mathcal{D}_{N+M}||^r]^{\frac{1}{r}} \leq O(MN^{-2}) + M^{\frac{2}{r}} N^{-\frac{3}{2} - \frac{1}{r} + o(1)}.$$

If additionally $\liminf \frac{M^q}{N} > 0$ for some $q < 2$, then for all $r \in (0, +\infty)$, there exists C such that for all $N \geq 1$,

$$\mathbb{E}^X [||\mathcal{D}_N| - |\mathcal{D}_{N+M}||^r]^{\frac{1}{r}} \leq CMN^{-2}.$$

Proof. We use the following convergence, which is the main result of [47].

$$\mathbb{E}^X [(n^2 |\{z \in \mathbb{R}^2 : \theta(z) = n\}| - \frac{1}{2\pi})^2] \xrightarrow{n \rightarrow \infty} 0. \quad (5.5)$$

In particular, there exists C such that for all $n \geq 1$, $\mathbb{E}^X [|\{z \in \mathbb{R}^2 : \theta(z) = n\}|^2]^{\frac{1}{2}} \leq Cn^{-2}$. Summing from $n = N$ to $N + M - 1$, we deduce that

$$\mathbb{E}^X [(|\mathcal{D}_N| - |\mathcal{D}_{N+M}|)^2]^{\frac{1}{2}} \leq CMN^{-2}. \quad (5.6)$$

This is sufficient to conclude in the case $r = 2$. The case $r < 2$ follows from Hölder inequality. For $r > 2$, we fix some $p > r$. From the triangle inequality,

$$\mathbb{E}^X [||\mathcal{D}_N| - |\mathcal{D}_{N+M}||^p]^{\frac{1}{p}} \leq \mathbb{E}^X [||\mathcal{D}_N| - \frac{1}{2\pi N}|^p]^{\frac{1}{p}} + \mathbb{E}^X [||\mathcal{D}_{N+M}| - \frac{1}{2\pi(N+M)}|^p]^{\frac{1}{p}} \frac{M}{2\pi N(N+M)}$$

By Theorem 2.1.1, there is thus C such that for all N and M ,

$$\mathbb{E}^X[(|\mathcal{D}_N| - |\mathcal{D}_{N+M}|)^p]^{\frac{1}{p}} \leq C(N^{-\frac{3}{2}+o(1)} + MN^{-2}). \quad (5.7)$$

We now interpolate between the inequalities (5.6) and (5.7). Setting $\theta = \frac{r-1-p^{-1}}{2-1-p^{-1}}$, the Hölder inequality is written

$$\|\cdot\|_{L^r} \leq \|\cdot\|_{L^2}^\theta \|\cdot\|_{L^p}^{1-\theta}.$$

Hence,

$$\mathbb{E}^X[(|\mathcal{D}_N| - |\mathcal{D}_{N+M}|)^r]^{\frac{1}{r}} \leq C(MN^{-2} + (MN^{-2})^\theta (N^{-\frac{3}{2}-o(1)})^{1-\theta}).$$

As p goes to infinity, θ goes to $\frac{2}{r}$, and we end up with

$$\mathbb{E}^X[(|\mathcal{D}_N| - |\mathcal{D}_{N+M}|)^r]^{\frac{1}{r}} \leq C(MN^{-2} + M^{\frac{2}{r}}N^{-\frac{3}{2}-\frac{1}{r}+o(1)}).$$

This is the first announced bound.

For the last bound, it suffices to remark that, for any $r > 2$, for ε small enough, $M^{\frac{2}{r}}N^{-\frac{3}{2}-\frac{1}{r}+\varepsilon}$ is negligible compared to MN^{-2} . \square

Remark 5.3.5. In [47], it is stated that the convergence (5.5) can be extended to higher moments, and the proof is sketched. We are convinced that this sketch can indeed, to the price of a lot of effort, be turned into a proof, but to the best of our knowledge, this has not been done. If this statement is true, as we think it is, the proof of Lemma 5.3.4 becomes almost trivial, and the additional assumption becomes superfluous.

Corollary 5.3.6. Let $M = M(N)$ be an integer-valued function of N such that $M^q N^{-1} \rightarrow \infty$ for some $q < 2$, and $MN^{-1} \rightarrow 0$ as N tends to infinity. Then, for all $p \in [1, +\infty)$, there exists C such that for all $N \geq 1$,

$$\|\mathbf{M}(\mathcal{D}_N) - \mathbf{M}(\mathcal{D}_{N+M})\|_{p,2} \leq CN^{-\nu} M^{\frac{\nu}{2}}.$$

Proof. Remark that $\mathcal{D}_{N+M} \subseteq \mathcal{D}_N$. We have

$$\begin{aligned} \|\mathbf{M}(\mathcal{D}_N) - \mathbf{M}(\mathcal{D}_{N+M})\|_{p,2} &= \mathbb{E}^X[\mathbb{E}^M[(\mathbf{M}(\mathcal{D}_N \setminus \mathcal{D}_{N+M}))^2]^{\frac{p}{2}}]^{\frac{1}{p}} \\ &\leq C\mathbb{E}^X[(|\mathcal{D}_N \setminus \mathcal{D}_{N+M}|^\nu + |\mathcal{D}_N \setminus \mathcal{D}_{N+M}|^2)^{\frac{p}{2}}]^{\frac{1}{p}} \quad (\text{using Lemma 5.2.2}). \end{aligned}$$

We apply Lemma 5.3.4 with $r = \frac{\nu p}{2}$ and with $r = p$, and we obtain

$$\mathbb{E}^X[\mathbb{E}^M[(\mathbf{M}(\mathcal{D}_N) - \mathbf{M}(\mathcal{D}_{N+M}))^2]^{\frac{p}{2}}]^{\frac{1}{p}} \leq C_2((MN^{-2})^{\frac{\nu}{2}} + MN^{-2}) \leq 2C_2 M^{\frac{\nu}{2}} N^{-\nu},$$

which we square to get the result. \square

We are now finally ready for the comparison between $\mathbf{M}(\mathcal{D}_N)$ and \mathbf{M}_N .

Proposition 5.3.7. Let $p \in (1, +\infty)$. Then, for all $t < \min(\frac{\nu}{8} \frac{p}{p-1}, \frac{1}{2})$ there exists C such that for all $N \geq 1$,

$$\|\mathbf{M}(\mathcal{D}_N) - \mathbf{M}_N\|_{p,2} \leq CN^{-\frac{3\nu}{4}+2t}.$$

Proof. Let us set $M_1 = \lfloor N^{\frac{1}{2}} \rfloor$ and $M_2 = \lfloor N^{\frac{1}{4}} \rfloor$. The exponents $\frac{1}{2}$ and $\frac{1}{4}$ here are chosen in order to optimize some bound later on, and we suggest the reader should think of M_1 and M_2 as ‘some powers of N , satisfying $1 \ll M_2 \ll M_1$ and $M_1 T \ll N$ ’ during the proof. Actually, the value $\frac{1}{4}$ can be replaced with any value strictly between 0 and $\frac{1}{2}$, which even allows to extend the result of the lemma to $t < \min(\frac{\nu}{4} \frac{p}{p-1}, \frac{1}{2})$. This, however, is useless for us.

For any fixed integer k , the relations $TM_2 \leq \frac{N}{k} - T$ and $kM_1 + (M_2 + 1)T < N$ holds as soon as N is large enough. We can then apply the Lemma 5.3.1. Since $\mathcal{D}_{N+TM_1}^i \cap \mathcal{D}_{N+TM_1}^j \subseteq \mathcal{D}_{\frac{N}{k}, M_1}^{i,j}$, we deduce the following inequalities, which holds \mathbb{P} -almost surely.

$$\sum_{i=1}^T M(\mathcal{D}_{N+TM_1}^i) - \sum_{i \neq j} M(\mathcal{D}_{\frac{N}{k}, M_1}^{i,j}) \leq M(\mathcal{D}_N) \leq \sum_{i=1}^T M(\mathcal{D}_{N-2TM_1}^i) + \sum_{i \neq j} M(\mathcal{D}_{\frac{N}{k}, M_1}^{i,j}) + \sum_{\mathbf{i} \in \mathbf{I}_{M_2}} M(\mathcal{D}_{M_2}^{\mathbf{i}}). \quad (5.8)$$

Remark that we have replaced the sets $\mathcal{D}_{N-kM_1-(M_2+1)T}^i$ that appears in Lemma 5.3.1 with the larger set $\mathcal{D}_{N-2TM_1}^i$. This is possible because $kM_1 + (M_2 + 1)T \leq 2TM_1$.

If we try to compare directly the first and last expressions of (5.8), we are lead to compare $\sum_{i=1}^T M(\mathcal{D}_{N-2TM_1}^i)$ with $\sum_{i=1}^T M(\mathcal{D}_{N+TM_1}^i)$, which is not very convenient. To circumvent the difficulty, we apply (5.8) with N replaced by $\tilde{N} = N - 3TM_1$, and also with N replaced by $\tilde{N} = N + 3TM_1$.

We then obtain the following inequalities, \mathbb{P} -almost surely.

$$\begin{aligned} M(\mathcal{D}_{N+3TM_1}) - 2 \sum_{i \neq j} M(\mathcal{D}_{\frac{N}{k}, M_1}^{i,j}) - \sum_{\mathbf{i}} M(\mathcal{D}_{M_2}^{\mathbf{i}}) &\leq \sum_{i=1}^T M(\mathcal{D}_{N+TM_1}^i) - \sum_{i \neq j} M(\mathcal{D}_{\frac{N}{k}, M_1}^{i,j}) \\ &\leq M(\mathcal{D}_N) \leq \sum_{i=1}^T M(\mathcal{D}_{N-2TM_1}^i) + \sum_{i \neq j} M(\mathcal{D}_{\frac{N}{k}, M_1}^{i,j}) + \sum_{\mathbf{i}} M(\mathcal{D}_{M_2}^{\mathbf{i}}) \\ &\leq M(\mathcal{D}_{N-3TM_1}) + 2 \sum_{i \neq j} M(\mathcal{D}_{\frac{N-TM_1}{k}, M_1}^{i,j}) + \sum_{\mathbf{i}} M(\mathcal{D}_{M_2}^{\mathbf{i}}). \end{aligned} \quad (5.9)$$

The exact same inequalities also hold if the middle term $M(\mathcal{D}_N)$ is replaced by $M_N = \sum_{i=1}^T M(\mathcal{D}_N^i)$. It follows that the difference between $M(\mathcal{D}_N)$ and M_N is less than the difference between the left-most and right-most terms of (5.9):

$$|M(\mathcal{D}_N) - M_N| \leq (M(\mathcal{D}_{N-3TM_1}) - M(\mathcal{D}_{N+3TM_1})) + 4 \sum_{i \neq j} M(\mathcal{D}_{\frac{N-TM_1}{k}, M_1}^{i,j}) + 2 \sum_{\mathbf{i}} M(\mathcal{D}_{M_2}^{\mathbf{i}}). \quad (5.10)$$

The three terms on the right-hand side are the ones that appears in Corollary 5.3.3 and Lemma 5.3.6 (applied with $M = TM_1$). Applying these lemmas, we obtain

$$\begin{aligned} \|M(\mathcal{D}_N) - M_N\|_{p,2} &\leq C((TM_1)^{\frac{\nu}{2}} N^{-\nu} + \log(TNM_1 + 1)^{\frac{3\nu}{2} + \frac{1}{p}} T^{2 - \frac{1}{p} - \frac{\nu}{2}} N^{-\frac{\nu}{2}} M_1^{-\frac{\nu}{2}} \\ &\quad + \log(M_2 T + 1)^{(k+1)(\frac{\nu}{2} + \frac{1}{p}) - 2} T^{k - \frac{k}{p} - \frac{\nu}{2}} M_2^{-k \frac{\nu}{2}}) \\ &\leq C'(N^{-\frac{3\nu}{4} + t \frac{\nu}{2}} + \log(N + 1)^{\frac{3\nu}{2} + \frac{1}{p}} N^{-\frac{3\nu}{4} + t(2 - \frac{1}{p} - \frac{\nu}{2})} \\ &\quad + \log(N + 1)^{(k+1)(\frac{\nu}{2} + \frac{1}{p}) - 2} N^{-t \frac{\nu}{2} + k(t \frac{p-1}{p} - \frac{\nu}{8})}). \end{aligned}$$

The bound on t is such that the exponent factorized by k is strictly negative. It follows that for k sufficiently large, the last term is negligible compared to the others. We end up with, for some C, C', d , for all $N \geq 1$,

$$\|\mathbf{M}(\mathcal{D}_N) - \mathbf{M}_N\|_{p,2} \leq C \log(N+1) d N^{-\frac{3\nu}{4} + t \max(\frac{\nu}{2}, 2 - \frac{1}{p} - \frac{\nu}{2})} \leq C' N^{-\frac{3\nu}{4} + 2t}.$$

This concludes the proof. \square

Remark 5.3.8. *Let us recall that our ultimate goal is to show that $\|\mathbf{M}(\mathcal{D}_N) - \mathbf{M}(\mathcal{D}_{-N})\|_{p,2}$ is asymptotically less than $N^{-1-\varepsilon}$, for some $\varepsilon > 0$. The condition $\gamma < \sqrt{4/3}$ that we imposed in Theorem 1 is equivalent to the condition $\frac{3\nu}{4} > 1$, for which we just showed that $\|\mathbf{M}(\mathcal{D}_N) - \mathbf{M}_N\|_{p,2}$ is asymptotically less than $N^{-1-\varepsilon}$, provided t and ε are small enough. If we were to try to improve our proof to larger γ , the more important step would be to improve the bound $\frac{3\nu}{4}$ in Proposition 5.3.7.*

5.4 Estimation of \mathbf{M}_N

We now take the next step towards the proof of Theorem 1, according to the strategy presented in the introduction and recalled at the beginning of the previous section. We use the notation introduced in Section 5.3.

Our next goal is thus to estimate \mathbf{M}_N , and more precisely

$$(\mathbf{M}_N - \mathbf{M}_{-N})^2 = \sum_{i,j=1}^T (\mathbf{M}(\mathcal{D}_N^i) - \mathbf{M}(\mathcal{D}_{-N}^i))(\mathbf{M}(\mathcal{D}_N^j) - \mathbf{M}(\mathcal{D}_{-N}^j)).$$

This task will, in fact, only be completed in Section 5.5, because of some ‘bad’ couples (i, j) in this sum. Basically, we expect the expression $(\mathbf{M}(\mathcal{D}_N^i) - \mathbf{M}(\mathcal{D}_{-N}^i))(\mathbf{M}(\mathcal{D}_N^j) - \mathbf{M}(\mathcal{D}_{-N}^j))$ to have a $\mathbb{P}^{\mathbf{M}}$ -expectation very close to 0, provided that X^i and X^j are far from each other: these are the good couples (i, j) . When these Brownian pieces go close to each other (bad couples), it is difficult to have a good bound on the $\mathbb{P}^{\mathbf{M}}$ -expectation. To prove that these bad couples do not contribute too much to \mathbf{M}_N is a substantial problem on its own, and we will address it in the next section. In the present section, we bound the sum over the good couples only.⁴

Let us introduce a notation which will make many expressions much shorter than they would otherwise be: we set, for all $i \in \{1, \dots, T\}$,

$$R_i = \mathbf{M}(\mathcal{D}_N^i) - \mathbf{M}(\mathcal{D}_{-N}^i). \quad (5.11)$$

We fix some $\varepsilon > 0$ and set $\beta = \frac{1}{2} - \frac{\varepsilon}{3}$. For $j > i + 1$, we define the following events of large probability in Ω^X :

$$E = \{\|X\|_{C^\beta} \leq \frac{1}{4}T^{\frac{\varepsilon}{3}}\}, \quad F_{i,j} = \{\|X_{(i+1)T-1} - X_{jT-1}\| \geq T^{-\frac{1}{2}+\varepsilon}\}.$$

For $j \in \{i, i+1\}$, we simply set $F_{i,j} = \emptyset$ in order to harmonize some results. The complement of an event G in Ω^X is denoted by G^c . We first get rid of the event E^c .

⁴The proofs presented in this section can be substantially simplified in the case where $p = 2$, using the symmetry properties of the Brownian motion. The corresponding arguments are less robust but much simpler than the ones that we give below, and we will include them in a forthcoming version of this paper.

Lemma 5.4.1. *For all $p \in [1, +\infty)$, and all $r > 0$, there exists C such that for all $N \geq 1$,*

$$\|\mathbb{1}_{E^c}(\mathbf{M}_N - \mathbf{M}_{-N})\|_{p,2} \leq CN^{-r}.$$

Proof. From the triangle inequality in $L^p(\Omega^X, L^2(\Omega^M))$ and Cauchy–Schwarz inequality between $\mathbb{1}_{E^c}$ and $\mathbb{E}^M[R_i^2]^{\frac{p}{2}}$ in Ω^X ,

$$\|\mathbb{1}_{E^c}(\mathbf{M}_N - \mathbf{M}_{-N})\|_{p,2} \leq \sum_{i=1}^T \|\mathbb{1}_{E^c} R_i\|_{p,2} = \sum_{i=1}^T \mathbb{E}^X [\mathbb{E}^M[\mathbb{1}_{E^c} R_i^2]^{\frac{p}{2}}]^{\frac{1}{p}} \leq \sum_{i=1}^T \mathbb{P}^X(E^c)^{\frac{1}{2p}} \mathbb{E}^X [\mathbb{E}^M[R_i^2]^p]^{\frac{1}{2p}}.$$

By Lemma 5.2.2, for some C , for all N ,

$$\mathbb{E}^M[\mathbf{M}(\mathcal{D}_N^i)^2] \leq C(|\mathcal{D}_N^i|^\nu + |\mathcal{D}_N^i|^2).$$

By Theorem 2.1.1 and a scaling argument, for some C' , for all N ,

$$\mathbb{E}^X[|\mathcal{D}_N^i|^{\nu p} + |\mathcal{D}_N^i|^{2p}] \leq C'(TN)^{-\nu p} \leq C'.$$

The same bounds hold for N replaced with $-N$, and we deduce that for some $C^{(2)}$, for all N ,

$$\mathbb{E}^X[\mathbb{1}_{E^c} \mathbb{E}^M[(\mathbf{M}_N - \mathbf{M}_{-N})^2]^{\frac{p}{2}}]^{\frac{1}{p}} \leq C^{(2)} T \mathbb{P}^X(E^c)^{\frac{1}{2p}}.$$

From Kolmogorov continuity theorem, for all $\beta < \frac{1}{2}$, $\|X\|_{C^\beta}$ admits moments of all orders. From Markov's inequality, the tail probability $\mathbb{P}^X(E^c)$ decreases more quickly than any polynomial in T (hence in N). This concludes the proof. \square

Lemma 5.4.2. *For all $p \in [2, \frac{4}{\gamma^2})$, for all $\varepsilon > 0$ and $t > 0$,*

$$\mathbb{E}^X \left[\left[\mathbb{E}^M \left[\sum_{i,j=1}^T \mathbb{1}_{E \cap F_{i,j}} R_i R_j \right]^{\frac{p}{2}} \right]^{\frac{1}{p}} \leq CT^{\frac{\varepsilon}{2}} N^{-1+o(1)} (N^{-\frac{1}{4}} + T^{\frac{\gamma^2}{4} - \frac{1}{p}}).$$

Proof. Let $i, j \in \{1, \dots, T\}$ be such that $j > i + 1$. During this proof, in order to try and maintain the length of expressions within reasonable bounds, we will write

$$\begin{aligned} D^{ij} &= |\mathcal{D}_N^i| + |\mathcal{D}_{-N}^i| + |\mathcal{D}_N^j| + |\mathcal{D}_{-N}^j|, \\ \Delta D^{ij} &= \left| |\mathcal{D}_N^i| - |\mathcal{D}_{-N}^i| \right| + \left| |\mathcal{D}_N^j| - |\mathcal{D}_{-N}^j| \right|, \\ X_{i,j} &= |X_{(i+1)T-1} - X_{jT-1}|. \end{aligned}$$

On $F_{i,j} \cap E$, both $4d_{\text{sup}}(\mathcal{D}_N^i, \mathcal{D}_{-N}^i)$ and $4d_{\text{sup}}(\mathcal{D}_N^j, \mathcal{D}_{-N}^j)$ are less than $d_{\text{inf}}(\mathcal{D}_N^i, \mathcal{D}_N^j)$, so that we can apply Lemma 5.2.3. Since $d_{\text{inf}}(\mathcal{D}_N^i, \mathcal{D}_N^j) \leq X_{i,j}$, we obtain, for some constant C ,

$$|\mathbb{E}^M[R_i R_j]| \leq C(X_{i,j}^{-\gamma^2} (\Delta D^{ij})^2 + T^{-\beta} \|X\|_{C^\beta} X_{i,j}^{-1-\gamma^2} D^{ij} \Delta D^{ij} + T^{-2\beta} \|X\|_{C^\beta}^2 X_{i,j}^{-2-\gamma^2} (D^{ij})^2).$$

We raise to the power $\frac{p}{2}$, multiply by $\mathbb{1}_{E \cap F_{i,j}}$, and take the \mathbb{P}^X -expectation. We obtain

$$\begin{aligned} \mathbb{E}^X \left[\mathbb{1}_{E \cap F_{i,j}} |\mathbb{E}^M[R_i R_j]|^{\frac{p}{2}} \right] &\leq C' (\mathbb{E}^X [\mathbb{1}_{F_{i,j}} X_{i,j}^{-\frac{p}{2}\gamma^2} (\Delta D^{ij})^p]) \\ &+ T^{-\frac{p\beta}{2}} \mathbb{E}^X [\mathbb{1}_{F_{i,j}} \|X\|_{C^\beta}^{\frac{p}{2}} X_{i,j}^{-\frac{p}{2}(1+\gamma^2)} (D^{ij})^{\frac{p}{2}} (\Delta D^{ij})^{\frac{p}{2}}] + T^{-p\beta} \mathbb{E}^X [\mathbb{1}_{F_{i,j}} \|X\|_{C^\beta}^p X_{i,j}^{-\frac{p}{2}(2+\gamma^2)} (D^{ij})^p]. \end{aligned} \quad (5.12)$$

The variables D^{ij} and ΔD^{ij} are measurable with respect to the σ -algebra generated by the families $(X_s)_{s \leq (i+1)T^{-1}}$ and $(X_s - X_{jT^{-1}})_{s \geq jT^{-1}}$, and hence jointly independent from $X_{i,j}$. Thus,

$$\begin{aligned} \mathbb{E}^X [\mathbb{1}_{F_{i,j}} X_{i,j}^{-\frac{p}{2}\gamma^2} (\Delta D^{ij})^p] &= \mathbb{E}^X [\mathbb{1}_{F_{i,j}} X_{i,j}^{-\frac{p}{2}\gamma^2}] \mathbb{E}^X [(\Delta D^{ij})^p], \\ \mathbb{E}^X [\mathbb{1}_{F_{i,j}} X_{i,j}^{-\frac{p}{2}(2+\gamma^2)} (D^{ij})^p] &= \mathbb{E}^X [\mathbb{1}_{F_{i,j}} X_{i,j}^{-\frac{p}{2}(2+\gamma^2)}] \mathbb{E}^X [(D^{ij})^p], \\ \mathbb{E}^X [\mathbb{1}_{F_{i,j}} X_{i,j}^{-\frac{p}{2}(1+\gamma^2)} (D^{ij})^{\frac{p}{2}} (\Delta D^{ij})^{\frac{p}{2}}] &= \mathbb{E}^X [\mathbb{1}_{F_{i,j}} X_{i,j}^{-\frac{p}{2}(1+\gamma^2)}] \mathbb{E}^X [(D^{ij})^{\frac{p}{2}} (\Delta D^{ij})^{\frac{p}{2}}]. \end{aligned} \quad (5.13)$$

With Theorem 2.1.1 and the scaling properties of the Brownian motion, we obtain the following bounds. For all $r \in [1, +\infty)$, there exists C such that for all N ,

$$\mathbb{E}^X [(D^{ij})^r]^{\frac{1}{r}} \leq CT^{-1}N^{-1}, \quad \mathbb{E}^X [(\Delta D^{ij})^r]^{\frac{1}{r}} \leq T^{-1}N^{-\frac{3}{2}+o(1)}. \quad (5.14)$$

We also need to control the expectations that depends on $X_{i,j}$. This variable is distributed according to $2\pi p_{(j-i-1)T^{-1}}(u)u \, du$, where du denotes the Lebesgue measure on \mathbb{R}^+ and $p_t(u) = (2\pi t)^{-1} \exp(-\frac{u^2}{2t})$.

With elementary computations, we obtain, for any $r > 0$,

$$\begin{aligned} \mathbb{E}^X [\mathbb{1}_{F_{i,j}} X_{i,j}^{-r}] &= 2\pi \int_{T^{-\frac{1}{2}+\varepsilon}}^{+\infty} u^{1-r} p_{(j-i-1)T^{-1}}(u) \, du \\ &= (T^{\frac{1}{2}}(j-i-1)^{-\frac{1}{2}})^r \int_{(j-i-1)^{-\frac{1}{2}}T^\varepsilon}^{+\infty} \rho^{1-r} p_1(\rho) \, d\rho \\ &\leq \begin{cases} C & T^{\frac{r}{2}}(j-i-1)^{-\frac{r}{2}} & \text{if } 1-r > -1 \\ C \log(T+1)T^{\frac{r}{2}}(j-i-1)^{-\frac{r}{2}} & \text{if } 1-r = -1 \\ C & T^{\frac{r}{2}}(j-i-1)^{-1} & \text{if } 1-r < -1 \end{cases} \\ &\leq C \log(T+1)T^{\frac{r}{2}}(j-i-1)^{-\min(\frac{r}{2}, 1)}. \end{aligned} \quad (5.15)$$

Combining (5.12), (5.13), (5.14) and (5.15) leads to

$$\begin{aligned} \mathbb{E}^X [\mathbb{1}_{E \cap F_{i,j}} |\mathbb{E}^M [R_i R_j]|^{\frac{p}{2}}] &\leq C \log(T+1) (T^{\frac{p\gamma^2}{4}}(j-i-1)^{-\min(\frac{p\gamma^2}{4}, 1)} T^{-p} N^{-\frac{3}{2}p+o(1)} \\ &\quad + T^{-\frac{p}{4}+\frac{\varepsilon p}{3}} T^{\frac{p}{4}(1+\gamma^2)}(j-i-1)^{-\min(\frac{p}{4}(1+\gamma^2), 1)} T^{-p} N^{-\frac{5p}{4}+o(1)} \\ &\quad + T^{-\frac{2p}{4}+\frac{\varepsilon p}{2}} T^{\frac{p}{4}(2+\gamma^2)}(j-i-1)^{-\min(\frac{p}{4}(2+\gamma^2), 1)} T^{-p} N^{-p}) \\ &\leq C' \log(T+1) T^{\frac{\varepsilon p}{2}} N^{-p} T^{p(\frac{\gamma^2}{4}-1)} ((j-i-1)^{-\frac{p\gamma^2}{4}} N^{-\frac{p}{4}+o(1)} + (j-i-1)^{-1}). \end{aligned}$$

From the triangle inequality in $L^{\frac{p}{2}}(\Omega^X)$,

$$\begin{aligned} \mathbb{E}^X \left[\left| \mathbb{E}^M \left[\sum_{i,j=1}^T \mathbb{1}_{E \cap F_{i,j}} R_i R_j \right] \right|^{\frac{p}{2}} \right]^{\frac{1}{p}} &\leq \left(\sum_{i,j=1}^T \mathbb{E}^X \left[\left| \mathbb{E}^M \left[\mathbb{1}_{E \cap F_{i,j}} R_i R_j \right] \right|^{\frac{p}{2}} \right]^{\frac{2}{p}} \right)^{\frac{1}{2}} \\ &\leq \left(\sum_{i,j=1}^T (C \log(T+1) T^{\frac{\varepsilon p}{2}} N^{-p} T^{p(\frac{\gamma^2}{4}-1)} \right. \\ &\quad \left. ((j-i-1)^{-\min(\frac{p\gamma^2}{4}, 1)} N^{-\frac{p}{2}+o(1)} + (j-i-1)^{-\min(\frac{p}{4}(1+\gamma^2), 1)} N^{-\frac{p}{4}+o(1)} + (j-i-1)^{-1}) \right)^{\frac{1}{2}} \\ &\leq C' \log(T+1)^{\frac{1}{p}} T^{\frac{\varepsilon}{2}} N^{-1} T^{\frac{\gamma^2}{4}} (N^{-\frac{1}{4}+o(1)} T^{-\frac{\gamma^2}{4}} + T^{-\frac{1}{p}}). \end{aligned}$$

Since $\log(T+1) \leq N^{o(1)}$, This concludes the proof. \square

5.5 Bootstrapping the bounds

Let us summarize what we did up to here. Our goal is to bound $\|\mathbf{M}(\mathcal{D}_N) - \mathbf{M}(\mathcal{D}_{-N})\|_{p,2}$. In Section 5.3, we showed that, in this estimation, $\mathbf{M}(\mathcal{D}_N)$ can safely be replaced with \mathbf{M}_N , provided t is small and $\gamma < \sqrt{4/3}$. Then, we split $(\mathbf{M}_N - \mathbf{M}_{-N})^2$ into a sum of two terms. Let us call them \mathbf{M}_{good} and \mathbf{M}_{bad} . The first one is a sum over ‘good terms’, and we have been able in Section 5.4 to show that this term is small, provided $p < \frac{4}{\gamma^2}$.

What remains to be done is thus to control \mathbf{M}_{bad} . Here is the place where the bootstrap really starts. In a perfect world, our dearest wish would be to have $\|\mathbf{M}_{\text{bad}}\|_{p,2} < CN^{-1-h}$, for some C and $h > 0$. This however is not what we will obtain in the first place. We will first give a bound on \mathbf{M}_{bad} which is something like

$$\|\mathbf{M}_{\text{bad}}\|_{p,2} < CN^{\xi} \|\mathbf{M}(\mathcal{D}_N) - \mathbf{M}(\mathcal{D}_{-N})\|_{p,2}. \quad (5.16)$$

It might seem at first that this approach is doomed to fail, because it seems that the problem is now to control $\|\mathbf{M}(\mathcal{D}_N) - \mathbf{M}(\mathcal{D}_{-N})\|_{p,2}$, which actually was the problem we started with. The crucial point is to obtain a *negative* exponent ξ : indeed, in that case, the relation

$$\|\mathbf{M}(\mathcal{D}_N) - \mathbf{M}(\mathcal{D}_{-N})\|_{p,2} \leq CN^{-1-\varepsilon} + CN^{\xi} \|\mathbf{M}(\mathcal{D}_N) - \mathbf{M}(\mathcal{D}_{-N})\|_{p,2}$$

does imply

$$\|\mathbf{M}(\mathcal{D}_N) - \mathbf{M}(\mathcal{D}_{-N})\|_{p,2} \leq C' N^{-1-\varepsilon},$$

for a new constant C' .

We will show a relation of the form (5.16), with $\xi = t(\frac{\gamma^2}{4} - \frac{1}{p})$. Let us recall that $\mathcal{T}(\mathbf{M})$ is the set of random measures obtained from \mathbf{M} by translation by a random variable independent from \mathbf{M} , and possibly a symmetry with respect to the horizontal axis.

Let us also recall that the parameter $\varepsilon > 0$ appears in the definition of the event $F_{i,j}$.

Lemma 5.5.1. *Set $t > 0$, $p \in [2, \frac{4}{\gamma^2})$, and $\zeta \in \mathbb{R}$. Assume that there exists C such that for all $N \geq 1$,*

$$\|\mathbf{M}'(\mathcal{D}_N) - \mathbf{M}'(\mathcal{D}_{-N})\|_{p,2} \leq CN^{\zeta}.$$

Then, for all $\varepsilon > 0$, there exists a constant C' such that for all $N \geq 1$,

$$\mathbb{E}^X \left[\mathbb{E}^M \left[\sum_{1 \leq i \leq j \leq T} \mathbb{1}_{F_{i,j}^c} |R_i R_j| \right]^{\frac{p}{2}} \right]^{\frac{1}{p}} \leq C' \log(T+1)^{\frac{1}{p}} T^{\frac{\gamma^2}{4} - \frac{1}{p} + \varepsilon} N^\zeta.$$

Proof. Before we dive into the proof, let us look at the behaviour of $\|\mathbf{M}\|_0$ under scaling of \mathbf{M} . For all $z \in \mathbb{R}^2$ and $\lambda \geq 1$, let $\mathbf{M}_{z,\lambda}$ be the measure defined by setting

$$\mathbf{M}_{z,\lambda}(A) = \mathbf{M}(\lambda^{-\frac{1}{2}}A + z).$$

In particular, $\mathbf{M}_{z,1} = \tau_z(\mathbf{M})$ with the definition of Section 5.2. For A with $|A| \leq 1$, we have $|\lambda^{-\frac{1}{2}}A + z| \leq 1$, so that

$$\begin{aligned} \mathbb{E}[\mathbf{M}_{z,\lambda}(A)^2]^{\frac{1}{2}} &\leq \|\mathbf{M}\|_0 |\lambda^{-\frac{1}{2}}A + z|^{\frac{\nu}{2}} \\ &= \|\mathbf{M}\|_0 \lambda^{-\frac{\nu}{2}} |A|^{\frac{\nu}{2}}. \end{aligned}$$

Thus, $\|\mathbf{M}_{z,\lambda}\|_0 \leq \lambda^{-\frac{\nu}{2}} \|\mathbf{M}\|_0$. Similarly, we have $\|\mathbf{M}_{z,\lambda}\|_2 \leq \lambda^{-\frac{\nu}{2}} \|\mathbf{M}\|_2$. Besides, the assumption of the lemma extends automatically to all $\mathbf{M}' \in \mathcal{T}(M)$: for all $\mathbf{M}' \in \mathcal{T}(M)$, for all $N \geq 1$,

$$\|\mathbf{M}'(\mathcal{D}_N) - \mathbf{M}'(\mathcal{D}_{-N})\|_{p,2} \leq CN^\zeta.$$

That being said, let us start the proof. Let us fix two indices $i, j \in \{1, \dots, T\}$ with $i \leq j$. We bound $|R_i R_j|$ by $\frac{1}{2}(R_i^2 + R_j^2)$, and we will treat separately the term with i from the term with j . The reason why we do not apply the same treatment to these two terms is that the event $F_{i,j}^c$ is independent of R_i but *not* of R_j .

For $i \in \{1, \dots, T\}$, let us denote by J_i the random variable

$$J_i = \sum_{j \geq i} \mathbb{1}_{F_{i,j}^c},$$

which is independent of R_i . Then, using the triangle inequality in $L^{\frac{p}{2}}(\Omega^X)$ (recall that $p \geq 2$), we have

$$\begin{aligned} \mathbb{E}^X \left[\mathbb{E}^M \left[\sum_{j \geq i} \mathbb{1}_{F_{i,j}^c} R_i^2 \right]^{\frac{p}{2}} \right]^{\frac{1}{p}} &= \mathbb{E}^X \left[\mathbb{E}^M \left[\sum_{i=1}^T J_i R_i^2 \right]^{\frac{p}{2}} \right]^{\frac{1}{p}} \leq \left(\sum_{i=1}^T \mathbb{E}^X \left[\mathbb{E}^M \left[J_i R_i^2 \right]^{\frac{p}{2}} \right]^{\frac{2}{p}} \right)^{\frac{1}{2}} \\ &\leq \left(\sum_{i=1}^T \mathbb{E}^X \left[J_i^{\frac{p}{2}} \right]^{\frac{2}{p}} \|R_i\|_{p,2}^2 \right)^{\frac{1}{2}}. \end{aligned}$$

For $j > i + 1$,

$$\begin{aligned} \mathbb{P}^X(F_{i,j}^c) &= \mathbb{P}^X(\|X_{(i+1)T-1} - X_{jT-1}\| \leq T^{-\frac{1}{2}+\varepsilon}) = \int_0^{T^{-\frac{1}{2}+\varepsilon}} \frac{\exp(-\frac{r^2}{2(j-i-1)T^{-1}})}{2\pi(j-i-1)T^{-1}} r \, dr \\ &\leq \frac{T^{2\varepsilon}}{2(j-i-1)}. \end{aligned} \tag{5.17}$$

It follows that

$$\mathbb{E}^X [J_i^{\frac{p}{2}}] \leq T^{\frac{p}{2}-1} \sum_{j=i}^T \mathbb{P}^X (F_{i,j}^c) \leq CT^{\frac{p}{2}-1+2\varepsilon} \log(T+1).$$

Let $\tilde{\mathcal{D}}_N$ be a random set which is equal in distribution to \mathcal{D}_N under \mathbb{P}^X , but which is independent from X . Then, the random set \mathcal{D}_N^i is equal in distribution to $T^{-\frac{1}{2}}\tilde{\mathcal{D}}_N + X_i$. It follows that

$$\begin{aligned} \|R_i\|_{p,2} &= \|\mathbf{M}(\mathcal{D}_N^i) - \mathbf{M}(\mathcal{D}_{-N}^i)\|_{p,2} \leq \sup_{z \in \mathbb{R}^2} \|\mathbf{M}(T^{-\frac{1}{2}}\tilde{\mathcal{D}}_N + z) - \mathbf{M}(T^{-\frac{1}{2}}\tilde{\mathcal{D}}_N + z)\|_{p,2} \\ &= \sup_{z \in \mathbb{R}^2} \|\mathbf{M}_{z,T}(\mathcal{D}_N) - \mathbf{M}_{z,T}(\mathcal{D}_{-N})\|_{p,2} \\ &\leq C(\|\mathbf{M}_{z,T}\|_0 + \|\mathbf{M}_{z,T}\|_2)N^\zeta \\ &\leq CT^{-\frac{\nu}{2}}(\|\mathbf{M}\|_0 + \|\mathbf{M}\|_2)N^\zeta. \end{aligned}$$

Putting all together,

$$\begin{aligned} \mathbb{E}^X \left[\mathbb{E}^{\mathbf{M}} \left[\sum_{1 \leq i \leq j \leq T} \mathbb{1}_{F_{i,j}^c} R_i^{2\gamma} \right]^{\frac{p}{2}} \right]^{\frac{1}{p}} &\leq CT^{-\frac{\nu}{2}} N^\zeta \left(\sum_{i=1}^T C' \log(T+1)^{\frac{2}{p}} T^{1-\frac{2}{p}-\frac{4\varepsilon}{p}} \right)^{\frac{1}{2}} \\ &\leq C \log(T+1)^{\frac{1}{p}} T^{1-\frac{1}{p}-\frac{\nu}{2}+\frac{2\varepsilon}{p}} N^\zeta. \end{aligned}$$

Having dealt with the terms $i \leq j$, we now have to deal with the ones for which $j < i$. For this, we replace the Brownian motion X with the time-reversed Brownian motion $\tilde{X} : t \mapsto X_{1-t} - X_1$, which is independent from (X_1, \mathbf{M}) . We remark that $\mathbf{M}_{X_1,1}(\tilde{\mathcal{D}}_N^i) = \mathbf{M}(\mathcal{D}_{-N}^{T-i-1})$, where $\tilde{\mathcal{D}}_N^i$ is the set defined as \mathcal{D}_N^i , but with \tilde{X} replacing X . We are now back in the situation ' $i \leq j$ ' since $i' = T - i - 1 < T - j - 1 = j'$. We can then use the same bounds as in the case $i \leq j$, and we end up with the same bound, which concludes the proof. \square

We are now ready to prove Proposition 2. We first recall it.

Proposition (2). *Assume that $\gamma \leq \sqrt{4/3}$ and $p \in [2, \frac{4}{\gamma^2})$. Then, there exists $\delta > 0$ and C such that for all $N \geq 1$,*

$$\|\mathbf{M}(\mathcal{D}_N) - \mathbf{M}(\mathcal{D}_{-N})\|_{p,2} \leq CN^{-1-\delta}.$$

Proof. Set $t \in (0, \frac{3\nu}{8})$, so that, by Proposition 5.3.7, there exists $\delta_1 > 0, C_1$ such that for all $N \geq 1$,

$$\|\mathbf{M}(\mathcal{D}_N) - \mathbf{M}_N\|_{p,2} \leq C_1 N^{-1-\delta_1}.$$

Set also $\varepsilon \in (0, \min(\frac{1}{p} - \frac{\gamma^2}{4}, \frac{1}{2}))$, and $\delta_2 \in (0, t(\frac{1}{p} - \frac{\gamma^2}{4} - \varepsilon))$, so that by Lemma 5.4.2, there exists C_2 such that for all $N \geq 1$,

$$\left\| \mathbb{E}^{\mathbf{M}} \left[\sum_{i,j} \mathbb{1}_{E \cap F_{i,j}} R_i R_j \right]^{\frac{1}{2}} \right\|_p \leq C_2 N^{-1-\delta_2}.$$

We inductively show that for all $k \in \mathbb{N}$, there exists a constant C such that

$$\|\mathbf{M}(\mathcal{D}_N) - \mathbf{M}(\mathcal{D}_{-N})\|_{p,2} \leq C(N^{-1-\min(\delta_1, \delta_2)} + N^{-\frac{\nu}{2}-k\delta_2}).$$

At rank $k = 0$, it follows directly from Lemma 5.2.2.

The induction hypothesis, together with Lemma 5.5.1, ensures that there exists C such that for all $N \geq 1$,

$$\left\| \mathbb{E}^{\mathbf{M}} \left[\sum_{i,j} \mathbb{1}_{E \cap F_{i,j}^c} R_i R_j \right]^{\frac{1}{2}} \right\|_p \leq CN^{\max(-1-\delta_1, -1-\delta_2, \xi - k\delta_2)}.$$

To go from rank k to rank $k + 1$, let us decompose $\|\mathbf{M}(\mathcal{D}_N) - \mathbf{M}(\mathcal{D}_{-N})\|_{p,2}$ as follows:

$$\begin{aligned} \|\mathbf{M}'(\mathcal{D}_N) - \mathbf{M}'(\mathcal{D}_{-N})\|_{p,2} &\leq \|\mathbf{M}(\mathcal{D}_N) - \mathbf{M}_N\|_{p,2} + \|\mathbf{M}(\mathcal{D}_{-N}) - \mathbf{M}_{-N}\|_{p,2} + \|\mathbf{M}_N - \mathbf{M}_{-N}\|_{p,2} \\ &\leq 2C_1 N^{-1-\delta_1} + \left\| \mathbb{E}^{\mathbf{M}} \left[\sum_{i,j} \mathbb{1}_{E^c} R_i R_j \right]^{\frac{1}{2}} \right\|_p + \left\| \mathbb{E}^{\mathbf{M}} \left[\sum_{i,j} \mathbb{1}_{E \cap F_{i,j}} R_i R_j \right]^{\frac{1}{2}} \right\|_p \\ &\quad + \left\| \mathbb{E}^{\mathbf{M}} \left[\sum_{i,j} \mathbb{1}_{E \cap F_{i,j}^c} R_i R_j \right]^{\frac{1}{2}} \right\|_p \\ &\leq 2C_1 N^{-1-\delta_1} + CN^{-r} + C_2 N^{-1-\delta_2} + CN^{\max(-1-\delta_1, -1-\delta_2, \xi - k\delta_2)}, \end{aligned}$$

which implies the induction hypothesis at rank $k + 1$. This concludes the induction. For k large enough, we obtain

$$\|\mathbf{M}(\mathcal{D}_N) - \mathbf{M}(\mathcal{D}_{-N})\|_{p,2} \leq CN^{-1-\min(\delta_1, \delta_2)},$$

which concludes the proof of the proposition, hence also of Theorem 1. \square

The work that we have done so far allowed us to define the ‘algebraic Liouville area enclosed by the Brownian curve’ as the \mathbb{P} -almost sure limit

$$\mathbb{A}_{0,1} = \lim_{K \rightarrow +\infty} \int_{\mathbb{R}^2} \max(-K, \min(\theta_{X|_{[0,1]}}, K)) \, d\mathbf{M}.$$

Our reasoning extends without trouble if we replace $(0, 1)$ with any couple $(s, t) \in \Delta = \{(s, t) \in [0, 1]^2 : s \leq t\}$: for all such couple, \mathbb{P} -almost surely, the limit

$$\mathbb{A}_{s,t} = \lim_{K \rightarrow +\infty} \int_{\mathbb{R}^2} \max(-K, \min(\theta_{X|_{[s,t]}}, K)) \, d\mathbf{M} \tag{5.18}$$

exists. The fact that the trajectory now starts from a random point does not necessitate any additional work.

In the next chapter, we investigate the path properties of $\mathbb{A}_{s,t}$.

Chapter 6

Lévy and Young area for the Liouville measure: path properties

We extend the construction of the previous section to the case of curves with sufficient Hölder continuity. We also give trajectorial properties of the map which associated to (s, t) the area $\mathbb{A}_{s,t}^Y$ delimited by $Y_{|[s,t]}$.

The framework in this chapter is the same as in the previous one. The tools we use, nonetheless, are largely different. Therefore, it is not necessary to have understood the proof of the previous chapter in order to understand the proofs in this chapter.

6.1 The case of smoother curves

In this section, we replace the planar Brownian motion X with a function $Y : [0, 1] \rightarrow \mathbb{R}^2$ which is α -Hölder continuous. We will say that we work under the *relaxed assumptions* if we only assume that $\gamma < 2$ and $\alpha > \frac{1}{2}$, and under the *strengthened assumptions* if we assume $\gamma < \sqrt{2}$ and $\alpha > \frac{1}{2(1-\frac{\gamma^2}{4})}$.

For a real number $q \in [0, \frac{4}{\gamma^2})$, we define

$$\xi(q) = q\left(1 + \frac{\gamma^2}{4}\right) - q^2 \frac{\gamma^2}{4},$$

the so-called *structure exponent* of M .

Under the relaxed assumptions, we will show that for all $(s, t) \in \Delta = \{(s, t) \in [0, 1]^2 : s \leq t\}$, the M -area $\mathbb{A}_{s,t}^Y$ delimited by $Y_{|[s,t]}$ is almost surely defined as

$$\mathbb{A}_{s,t}^Y = \int_{\mathbb{R}^2} \theta_{Y_{|[s,t]}} dM, \tag{6.1}$$

and lies in $L^1(\Omega^M)$.

Under the strengthened assumptions, we show that it actually lies in $L^2(\Omega^M)$, and that the map $\mathbb{A}^Y : \Delta \rightarrow L^2(\Omega^M)$ admits some Hölder regularity. ¹

¹The strengthened assumptions are necessary to work in the L^2 framework. Nonetheless, it should be possible

To simplify notation, we will write $Y_{s,t} = Y_{|[s,t]}$. Let us recall that λ denotes the Lebesgue measure on the plane.

The following result gives us information about the winding function of a Hölder continuous curve.

Lemma 6.1.1. *If Y is α -Hölder continuous with $\alpha > \frac{1}{2}$, then θ_Y is defined Lebesgue-almost everywhere and lies in $L^r(\mathbb{R}^2, \lambda)$ for any $r \in [1, 2\alpha)$.*

For any $r \in [1, 2\alpha)$, there exists a constant C which depends on α and r but not on Y and such that for all $s < t \in [0, 1]$,

$$\|\theta_{Y_{s,t}}\|_{L^r(\mathbb{R}^2, \lambda)} \leq C(t-s)^{\frac{2\alpha}{r}} \|Y\|_{C^\alpha}^{\frac{2}{r}}.$$

Proof. This is a mild reformulation of Lemma 1.2.7, using the fact that the p -variation norm and the α -Hölder norms are related by $\|Y_{s,t}\|_p \leq (t-s)^\alpha \|Y\|_{C^\alpha}$, for $\alpha = p^{-1}$. \square

Corollary 6.1.2. *Under the relaxed assumptions, for all $(s, t) \in \Delta$, almost surely, the function $\theta_{Y_{s,t}}$ lies in $L^1(\mathbb{R}^2, \mathbb{M})$ and the random variable $\int_{\mathbb{R}^2} |\theta_{Y_{s,t}}| \, d\mathbb{M}$ lies in $L^1(\Omega^{\mathbb{M}}, \mathbb{P}^{\mathbb{M}})$.*

Proof. Remark that

$$\mathbb{E}^{\mathbb{M}} \left[\int_{\mathbb{R}^2} |\theta_Y| \, d\mathbb{M} \right] = \int_{\mathbb{R}^2} |\theta_Y| \, d\lambda.$$

It follows from Lemma 6.1.1 that the right-hand side is finite. \square

We are now interested in higher moments of $\int_{\mathbb{R}^2} \theta_Y \, d\lambda$.

Lemma 6.1.3. *Let $r > (1 - \frac{\gamma^2}{4})^{-1}$ and $f \in L^r(\mathbb{R}^2, \lambda)$ with support in the unit ball.*

Then, $\mathbb{P}^{\mathbb{M}}$ -almost surely, $f \in L^r(\mathbb{R}^2, \mathbb{M})$, and for any $\rho \in [1, r(1 - \frac{\gamma^2}{4}))$, the random variable $\|f\|_{L^\rho(\mathbb{R}^2, \mathbb{M})}$ lies in $L^{2\rho}(\Omega^{\mathbb{M}})$.

Besides, there exists a constant C , which depends only on r , ρ and K , and such that for all $f \in L^r(\mathbb{R}^2, \mathbb{M})$,

$$\| \|f\|_{L^\rho(\mathbb{R}^2, \mathbb{M})} \|_{L^{2\rho}(\Omega^{\mathbb{M}})} \leq C \|f\|_{L^r(\mathbb{R}^2, \lambda)}.$$

Proof. The fact that f lies $\mathbb{P}^{\mathbb{M}}$ -almost surely in $L^r(\mathbb{R}^2, \mathbb{M})$ follows directly from

$$\mathbb{E} \left[\int_{\mathbb{R}^2} |f|^r \, d\mathbb{M} \right] = \int_{\mathbb{R}^2} |f|^r \, d\lambda < +\infty.$$

For the remaining part of the lemma, let C be such that $K(z, w) \leq C + \log(|z - w|^{-1})$ for all $(z, w) \in (\mathbb{R}^2)^2$. We have

$$\begin{aligned} \mathbb{E} \left[\left(\int |f|^\rho \, d\mathbb{M} \right)^2 \right] &= e^{C\gamma^2} \int_{\mathbb{R}^2 \times \mathbb{R}^2} \frac{|f|^\rho(z) |f|^\rho(w)}{|z - w|^{\gamma^2}} \, dz \, dw \\ &= e^{C\gamma^2} \int_{B(0,1)} \frac{|f|^\rho(z)}{|z - w|^{\frac{\gamma^2}{2}}} \left(\int_{B(0,1)} \frac{|f|^\rho(w)}{|z - w|^{\frac{\gamma^2}{2}}} \, dw \right) \, dz. \end{aligned}$$

to extend some of the results of the next sections to the relaxed assumptions, provided that we succeed to work in $L^{1+\varepsilon}(\Omega^{\mathbb{M}})$.

By Hölder inequality applied with $p = \frac{r}{\rho} > \frac{1}{1-\frac{\gamma^2}{4}}$ and $q = \frac{r}{r-\rho} < \frac{4}{\gamma^2}$,

$$\int_{B(0,1)} \frac{|f|^\rho(w)}{|z-w|^{\frac{\gamma^2}{2}}} dw \leq \|f\|_{L^r(\mathbb{R}^2, \lambda)}^\rho \left(\int_{B(0,2)} \frac{1}{|w|^{\frac{\gamma^2}{2}}} dw \right)^{\frac{1}{q}}.$$

The latter integral is finite, and with another identical computation we end up with

$$\int_{\mathbb{R}^2} \frac{|f|^\rho(z)}{|z-w|^{\frac{\gamma^2}{2}}} \left(\int_{\mathbb{R}^2} \frac{|f|^\rho(w)}{|z-w|^{\frac{\gamma^2}{2}}} dw \right) dz \leq C' \|f\|_{L^r(\mathbb{R}^2, \lambda)}^{2\rho},$$

hence

$$\mathbb{E} \left[\left(\int |f|^\rho d\mathbb{M} \right)^2 \right]^{\frac{1}{2\rho}} \leq C'' \|f\|_{L^r(\mathbb{R}^2, \lambda)},$$

which concludes the proof. \square

Recall that $\nu = 2(1 - \frac{\gamma^2}{4})$.

Corollary 6.1.4. *Let $Y : [0, 1] \rightarrow \mathbb{R}^2$ be an α -Hölder continuous function for some $\alpha > \frac{1}{\nu}$. Then, for all $(s, t) \in \Delta$, $\mathbb{A}_{s,t}^Y$ lies in $L^2(\Omega^{\mathbb{M}}, \mathbb{P}^{\mathbb{M}})$. Besides, for all $\varepsilon > 0$, there exists C such that, for all $s < t$,*

$$\|\mathbb{A}_{s,t}^Y\|_{L^2(\Omega^{\mathbb{M}}, \mathbb{P}^{\mathbb{M}})} \leq C(t-s)^{\alpha\nu-\varepsilon}.$$

Proof. Lemma 6.1.1 ensures that for all $r \in (\frac{2}{\nu}, 2\alpha)$, there exists C such that for all $s < t \in [0, 1]$, $\theta_{Y_{s,t}} \in L^r(\mathbb{R}^2, \lambda)$ and $\|\theta_{Y_{s,t}}\|_{L^r(\mathbb{R}^2, \lambda)} \leq C(t-s)^{\frac{2\alpha}{r}}$.

Lemma 6.1.3 applied with $\rho = 1 < \frac{\nu r}{2}$ then ensures that $\mathbb{P}^{\mathbb{M}}$ -almost surely, $\theta_{Y_{s,t}} \in L^1(\mathbb{R}^2, \mathbb{M})$, and that

$$\|\mathbb{A}_{s,t}^Y\|_{L^2(\Omega^{\mathbb{M}}, \mathbb{P}^{\mathbb{M}})} \leq C'(t-s)^{\frac{2\alpha}{r}}.$$

We conclude by taking r arbitrarily close to $\frac{2}{\nu}$. \square

Remark 6.1.5. *We have already seen that the bound $r < 2\alpha$ in Lemma 6.1.1 is optimal, using the matryoshka circles of Figure 1.1.*

In Lemma 6.1.3, the bound $\rho < \frac{\nu r}{2}$ is also optimal, in the sense that there exists $f \in L^r(\mathbb{R}^2, \lambda)$ such that $\|f\|_{L^\rho(\mathbb{R}^2, \mathbb{M})} \|f\|_{L^{2\rho}(\Omega^{\mathbb{M}})} = +\infty$ for $\rho > \frac{\nu r}{2}$ (roughly speaking, $L^r(\mathbb{R}^2, \lambda)$ is not included in the ‘fibered space’ $L^{2\rho}(\Omega^{\mathbb{M}}, L^\rho(\mathbb{R}^2, \mathbb{M}))$). To prove this, we could look precisely at the function θ_Y , where Y describes the matryoshka circles. Nonetheless, it is slightly simpler to look at the function $f : z \mapsto |z|^{-\alpha} \mathbb{1}_{B(0,1)}(z)$ with $\alpha < \frac{2}{r}$. This function is easily seen to lie in $L^r(\mathbb{R}^2, \lambda)$, but for any $\rho \geq \frac{\nu}{\alpha}$,

$$\begin{aligned} \mathbb{E}^{\mathbb{M}} \left[\left(\int_{\mathbb{R}^2} f(z)^\rho dz \right)^2 \right] &= \int_{B(0,1)^2} |z|^{-\alpha\rho} |w|^{-\alpha\rho} |z-w|^{-\gamma^2} dz dw \\ &\geq \int_{B(0,1)} \int_{B(0,|w|)} |w|^{-\alpha\rho} |w|^{-\alpha\rho} 2^{-\gamma^2} |w|^{-\gamma^2} dz dw \\ &= 2^{-\gamma^2} \pi \int_0^1 r^{-2\alpha\rho-\gamma^2+3} dr = +\infty. \end{aligned}$$

We do not know about the cases $r = 2\alpha$ and $\rho = \frac{\nu r}{2}$.

6.2 Weak Chen's relation

We will need the following version of the Chen relation, where the quantifier on s , u and t and the *almost sure* has been exchanged. Let us recall from the introduction that $T_{s,u,t}$ is the triangle delimited by Z_s , Z_u , and Z_t (the continuous function $Z : [0, 1] \rightarrow \mathbb{R}^2$ is assumed to be fixed), and that $\varepsilon_{s,u,t} \in \{\pm 1\}$ depends on the cyclic order between these points on the boundary of $T_{s,u,t}$.

Definition 6.2.1. Set $\Delta_3 = \{(s, t, u) : 0 \leq s \leq u \leq t \leq 1\}$. We say that a collection $(\mathbb{A}_{s,t})_{(s,t) \in \Delta}$ of random variables satisfies the weak Chen relation (relative to the continuous function Z) if for all $(s, u, t) \in \Delta_3$, \mathbb{P} -almost surely,

$$\mathbb{A}_{s,t} = \mathbb{A}_{s,u} + \mathbb{A}_{u,t} + \varepsilon_{s,u,t} \mathbb{M}(T_{s,u,t}).$$

Let us remark that, in contrast with the Chen relation, the weak Chen relation is preserved by the replacement of the family \mathbb{A} by one of its modifications (see Definition 6.3.1).

Lemma 6.2.2. Under the relaxed assumptions, that is, if $\alpha > \frac{1}{2}$ and $\gamma < 2$, the family of random variables \mathbb{A}^Y defined by (6.1) satisfies the weak Chen relation relative to Y .

Proof. We give two proofs. The first is much simpler, but understanding the second one will help us to understand the proof of the similar result for the Brownian motion.

First proof. Let us fix $(s, u, t) \in \Delta_3$. The equality

$$\theta_{s,t} = \theta_{s,u} + \theta_{u,t} + \varepsilon_{s,u,t} \mathbb{1}_{T_{s,u,t}}$$

holds λ -almost everywhere. Hence, $\mathbb{P}^{\mathbb{M}}$ -almost surely, this equality holds \mathbb{M} -almost everywhere. Since all of these functions are $\mathbb{P}^{\mathbb{M}}$ -almost surely \mathbb{M} -integrable (Corollary 6.1.2), $\mathbb{P}^{\mathbb{M}}$ -almost surely,

$$\int_{\mathbb{R}^2} \theta_{s,t} \, d\mathbb{M} = \int_{\mathbb{R}^2} \theta_{s,u} \, d\mathbb{M} + \int_{\mathbb{R}^2} \theta_{u,t} \, d\mathbb{M} + \int_{\mathbb{R}^2} \varepsilon_{s,u,t} \mathbb{1}_{T_{s,u,t}} \, d\mathbb{M}.$$

This is exactly the announced equality.

Second proof. Let us choose $(s, u, t) \in \Delta_3$. We decompose the plane according to the values of the two winding functions $\theta_{s,u}$ and $\theta_{u,t}$. Unfortunately, we also have to take the triangle $T_{s,u,t}$ into account, which muddles the proof. We invite the reader to write down the simplified version when $Y_s = Y_u = Y_t$.

For three relative integers j , k , and n , we define the following sets:

$$\begin{aligned} \mathcal{A}_{j,k} &= \{z \in \mathbb{R}^2 : \theta_{s,u}(z) = j, \theta_{u,t}(z) = k\}, \\ \mathcal{A}_n &= \{z \in \mathbb{R}^2 : \theta_{s,t}(z) = n\}, \\ \mathcal{A}_j^1 &= \{z \in \mathbb{R}^2 : \theta_{s,u}(z) = j\}, \\ \mathcal{A}_k^2 &= \{z \in \mathbb{R}^2 : \theta_{u,t}(z) = k\}. \end{aligned}$$

We also define $\mathcal{A}_{j,k}^\wedge$, \mathcal{A}_n^\wedge , $\mathcal{A}_n^{1,\wedge}$ and $\mathcal{A}_n^{2,\wedge}$ the intersection of the triangle $T_{s,u,t}$ with (respectively) $\mathcal{A}_{j,k}$, \mathcal{A}_n , \mathcal{A}_n^1 and \mathcal{A}_n^2 .

For $z \in \mathcal{A}_{j,k}^\wedge$, $\theta_{s,t}(z) = j + k + \varepsilon_{s,u,t}$. Hence, for all integer n ,

$$\mathcal{A}_n^\wedge = \bigsqcup_{j,k:j+k+\varepsilon_{s,u,t}=n} \mathcal{A}_{j,k}^\wedge.$$

Besides, for all $j \in \mathbb{N}$,

$$\mathcal{A}_j^{1,\wedge} = \bigsqcup_{k \in \mathbb{N}} \mathcal{A}_{j,k}^\wedge,$$

and for all $k \in \mathbb{N}$,

$$\mathcal{A}_k^{2,\wedge} = \bigsqcup_{j \in \mathbb{N}} \mathcal{A}_{j,k}^\wedge.$$

It follows from these relations that

$$\begin{aligned} \int_{T_{s,u,t}} \theta_{s,t} \, d\mathbf{M} &= \sum_{j,k \in \mathbb{N}^2} (j + k + \varepsilon_{s,u,t}) \mathbf{M}(\mathcal{A}_{j,k}^\wedge) \\ &= \varepsilon_{s,u,t} \mathbf{M}(T_{s,u,t}) + \sum_{j \in \mathbb{N}} j \mathbf{M}(\mathcal{A}_j^{1,\wedge}) + \sum_{k \in \mathbb{N}} k \mathbf{M}(\mathcal{A}_k^{2,\wedge}) \\ &= \varepsilon_{s,u,t} \mathbf{M}(T_{s,u,t}) + \int_{T_{s,u,t}} \theta_{s,u} \, d\mathbf{M} + \int_{T_{s,u,t}} \theta_{u,t} \, d\mathbf{M}. \end{aligned}$$

We then replace the sets $\mathcal{A}_{j,k}^\wedge$, \mathcal{A}_n^\wedge , $\mathcal{A}_n^{1,\wedge}$ and $\mathcal{A}_n^{2,\wedge}$ with the sets $\mathcal{A}_{j,k}^\vee$, \mathcal{A}_n^\vee , $\mathcal{A}_n^{1,\vee}$ and $\mathcal{A}_n^{2,\vee}$ defined as the intersection of $\mathbb{R}^2 \setminus T_{s,u,t}$ with (respectively) $\mathcal{A}_{j,k}$, \mathcal{A}_n , \mathcal{A}_n^1 and \mathcal{A}_n^2 . The same computations hold, except that for $z \in \mathcal{A}_{j,k}^\vee$, $\theta_{s,t}(z)$ is equal to $j + k$ instead of $j + k + \varepsilon_{s,u,t}$. We end up with

$$\int_{\mathbb{R}^2 \setminus T_{s,u,t}} \theta_{s,t} \, d\mathbf{M} = \int_{\mathbb{R}^2 \setminus T_{s,u,t}} \theta_{s,u} \, d\mathbf{M} + \int_{\mathbb{R}^2 \setminus T_{s,u,t}} \theta_{u,t} \, d\mathbf{M},$$

which allows to conclude the proof. \square

We now prove the corresponding result for the Brownian motion.

Lemma 6.2.3. *If $\gamma < \sqrt{4/3}$, then \mathbb{A}^X satisfies the weak Chen relation.*

Proof. We invite the reader to skim through the (rather long) proof a first time, and to convince herself or himself that it is merely a question of interchanging the summation order in a double sum, hence of showing that some residual terms are small.

We fix $(s, u, t) \in \Delta_3$. For simplicity, we assume that $\varepsilon(s, u, t) = 1$ (that is, the triangle has 'positive orientation').

For a positive integer N , we set

$$\begin{aligned} \mathcal{D}_N &= \{z : \theta_{X_{[s,t]}}(z) \geq N\} \\ \mathcal{D}_N^1 &= \{z : \theta_{X_{[s,u]}}(z) \geq N\} \\ \mathcal{D}_N^2 &= \{z : \theta_{X_{[u,t]}}(z) \geq N\}, \end{aligned}$$

and as usual the same notation with $N < 0$ is used with the inequality reversed.

For two positive integers N, M , we denote by $\mathcal{D}_{N,M}$ the set

$$\mathcal{D}_{N,M} = \left((\mathcal{D}_N^1 \cup \mathcal{D}_{-N}^1) \cap (\mathcal{D}_M^2 \cup \mathcal{D}_{-M}^2) \right) \cup \left((\mathcal{D}_M^1 \cup \mathcal{D}_{-M}^1) \cap (\mathcal{D}_N^2 \cup \mathcal{D}_{-N}^2) \right).$$

This is the set of points z such that among $|\theta_{s,u}(z)|$ and $|\theta_{u,t}(z)|$, one is at least N and the other is at least M . We also use the notations $\mathcal{A}_N, \mathcal{A}_{k,j}, \mathcal{A}_k^1$ and \mathcal{A}_j^2 , of the previous proof.

We will use the following bounds: for all $\varepsilon > 0$, there exists C such that for all $N, M \geq 1$,

$$\mathbb{E}^X[|\mathcal{D}_{N,M}|] \leq C(NM)^{-1+\varepsilon}. \quad (6.2)$$

This is an easy consequence of Lemma 2.4 in [43].

5.3.4

For a point $z \in \mathbb{R}^2 \setminus (T_{s,u,t} \cup \text{Range}(X))$, it is easily seen that $z \in \mathcal{A}_N$ if and only if there exists $k \in \mathbb{Z}$ such that $z \in \mathcal{A}_k^1 \cap \mathcal{A}_{N-k}^2$, in which case this k is unique. We let \mathbb{M}^\vee be the (random) measure defined by $\mathbb{M}^\vee(A) = \mathbb{M}(A \setminus T_{s,u,t})$.

For all N , we compute

$$\begin{aligned} \sum_{k=1}^N \mathbb{M}^\vee(\mathcal{D}_k) &= \sum_{k=1}^N \sum_{l=k}^{+\infty} \mathbb{M}^\vee(\mathcal{A}_l) = \sum_{k=1}^N \sum_{l=k}^{+\infty} \sum_{j=-\infty}^{+\infty} \mathbb{M}^\vee(\mathcal{A}_j^1 \cap \mathcal{A}_{l-j}^2) = \sum_{k=1}^N \sum_{j=-\infty}^{+\infty} \sum_{m=k-j}^{+\infty} \mathbb{M}^\vee(\mathcal{A}_j^1 \cap \mathcal{A}_m^2) \\ &= \sum_{j=-\infty}^{+\infty} \sum_{m=1-j}^{+\infty} \min(N, m+j) \mathbb{M}^\vee(\mathcal{A}_j^1 \cap \mathcal{A}_m^2) \\ &= \sum_{j=-\infty}^{+\infty} \sum_{m=-\infty}^{+\infty} \max(0, \min(N, m+j)) \mathbb{M}^\vee(\mathcal{A}_j^1 \cap \mathcal{A}_m^2). \end{aligned}$$

This computation remains true if we replace each set \mathcal{A}_ℓ^* by $\mathcal{A}_{-\ell}^*$ and leave everything else unchanged. Doing this substitution, subtracting the resulting equality from the one that we just obtained, and using the notation $[j]_n = \max(-n, \min(n, j))$, we find

$$\sum_{k=1}^N (\mathbb{M}^\vee(\mathcal{D}_k) - \mathbb{M}^\vee(\mathcal{D}_{-k})) = \sum_{j=-\infty}^{+\infty} \sum_{m=-\infty}^{+\infty} [m+j]_N \mathbb{M}^\vee(\mathcal{A}_j^1 \cap \mathcal{A}_m^2). \quad (6.3)$$

On the other hand, using the fact that $(\mathcal{A}_m^2)_{m \in \mathbb{Z}}$ is a partition of \mathbb{R}^2 , we find, by a superficially identical, but in fact different computation,

$$\begin{aligned} \sum_{k=1}^N \mathbb{M}^\vee(\mathcal{D}_k^1) &= \sum_{k=1}^N \sum_{j=k}^{+\infty} \mathbb{M}^\vee(\mathcal{A}_j^1) = \sum_{k=1}^N \sum_{j=k}^{+\infty} \sum_{m=-\infty}^{+\infty} \mathbb{M}^\vee(\mathcal{A}_j^1 \cap \mathcal{A}_m^2) \\ &= \sum_{j=1}^{+\infty} \sum_{m=-\infty}^{+\infty} \min(N, j) \mathbb{M}^\vee(\mathcal{A}_j^1 \cap \mathcal{A}_m^2) \\ &= \sum_{j=-\infty}^{+\infty} \sum_{m=-\infty}^{+\infty} \max(0, \min(N, j)) \mathbb{M}^\vee(\mathcal{A}_j^1 \cap \mathcal{A}_m^2). \end{aligned}$$

Replacing k by $-k$ as we did before and combining the two results, we obtain

$$\sum_{k=1}^N (\mathbf{M}^\vee(\mathcal{D}_k^1) - \mathbf{M}^\vee(\mathcal{D}_{-k}^1)) = \sum_{j=-\infty}^{+\infty} \sum_{m=-\infty}^{+\infty} [j]_N \mathbf{M}^\vee(\mathcal{A}_j^1 \cap \mathcal{A}_m^2). \quad (6.4)$$

The same equation holds after exchanging the superscript 1 and 2, so that

$$\begin{aligned} \sum_{k=1}^N \left((\mathbf{M}^\vee(\mathcal{D}_k) - \mathbf{M}^\vee(\mathcal{D}_{-k})) - (\mathbf{M}^\vee(\mathcal{D}_k^1) - \mathbf{M}^\vee(\mathcal{D}_{-k}^1) + \mathbf{M}^\vee(\mathcal{D}_k^2) - \mathbf{M}^\vee(\mathcal{D}_{-k}^2)) \right) \\ = \sum_{k,j=-\infty}^{+\infty} ([k+j]_N - [j]_N - [k]_N) \mathbf{M}^\vee(\mathcal{A}_j^1 \cap \mathcal{A}_k^2). \end{aligned} \quad (6.5)$$

Our goal is now to show that this sum goes to 0 as N goes to infinity. To this end, we decompose \mathbb{N}^2 as follows. We fix a parameter $m \in (0, 1)$ and set $M = \lfloor N^m \rfloor$. We then partition \mathbb{N}^2 into five subsets E_1, E_2, E_3, E_4, E_5 , illustrated on Figure 6.1.

$$\begin{aligned} E_1 &= [0, \frac{N}{2})^2, \\ E_2 &= ([M, +\infty) \times [\frac{N}{2}, +\infty)) \cup ([\frac{N}{2}, +\infty) \times [M, +\infty)), \\ E_3 &= ([0, M) \times [N-M, N+M)) \cup ([N-M, N+M) \times [0, M)), \\ E_4 &= ([0, M) \times [N+M, +\infty)) \cup ([N+M, +\infty) \times [0, M)), \\ E_5 &= ([0, M) \times [\frac{N}{2}, N-M)) \cup ([\frac{N}{2}, N-M) \times [0, M)). \end{aligned}$$

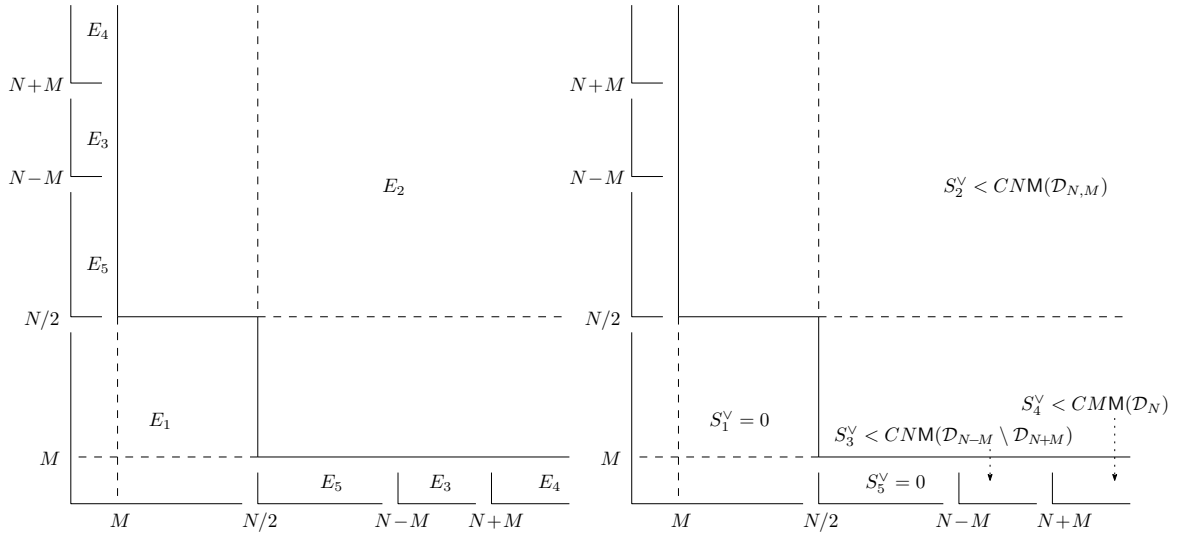

Figure 6.1: On the left: decomposition of \mathbb{N}^2 . On the right: approximate bounds on the corresponding sum.

We now partition \mathbb{Z}^2 into the sets $F_i = \{(k, j) \in \mathbb{Z}^2 : (|k|, |j|) \in E_i\}$, for $i \in \{1, \dots, 5\}$. We decompose the sum (6.5) accordingly into five sums $S_1^\vee, \dots, S_5^\vee$.

- It is easily seen that $S_1^\vee = S_5^\vee = 0$.
- For $(k, j) \in F_2$, the inequality $|(k+j)_N - (j)_N - (k)_N| \leq N$ holds. Moreover, the $\mathcal{A}_j^1 \cap \mathcal{A}_k^2$ are disjoint subsets of $\mathcal{D}_{N,M}$. Hence,

$$|S_2^\vee| \leq NM^\vee(\mathcal{D}_{N,M}).$$

- For $(k, j) \in F_3$, $|(k+j)_N - (j)_N - (k)_N| \leq N$, and the $\mathcal{A}_j^1 \cap \mathcal{A}_k^2$ are disjoint subsets of $(\mathcal{D}_{N-M}^1 \setminus \mathcal{D}_{N+M+1}^1) \cup (\mathcal{D}_{N-M}^1 \setminus \mathcal{D}_{N+M+1}^2)$. Hence,

$$|S_3^\vee| \leq N(M^\vee(\mathcal{D}_{N-M}^1 \setminus \mathcal{D}_{N+M+1}^1) + M^\vee(\mathcal{D}_{N-M}^2 \setminus \mathcal{D}_{N+M+1}^2)).$$

- For $(k, j) \in F_4$, $|(k+j)_N - (j)_N - (k)_N| \leq 2M$, and the $\mathcal{A}_j^1 \cap \mathcal{A}_k^2$ are disjoint subsets of $\mathcal{D}_N^1 \cup \mathcal{D}_{-N}^1 \cup \mathcal{D}_N^2 \cup \mathcal{D}_{-N}^2$. Hence,

$$|S_4^\vee| \leq 2M(M^\vee(\mathcal{D}_N^1) + M^\vee(\mathcal{D}_N^2)).$$

Altogether, we have

$$|S_1^\vee + \dots + S_5^\vee| \leq N(M^\vee(\mathcal{D}_{N,M}) + M^\vee(\mathcal{D}_{N-M}^1 \setminus \mathcal{D}_{N+M+1}^1) + M^\vee(\mathcal{D}_{N-M}^2 \setminus \mathcal{D}_{N+M+1}^2)) + 2M(M^\vee(\mathcal{D}_N^1) + M^\vee(\mathcal{D}_N^2)). \quad (6.6)$$

We take the expectation under \mathbb{P}^M on both sides. Using the fact that the intensity of the random measure M is the Lebesgue measure, we obtain

$$\mathbb{E}^M[|S_1 + \dots + S_5|] \leq N(|\mathcal{D}_{N,M}| + |\mathcal{D}_{N-M}^1 \setminus \mathcal{D}_{N+M+1}^1| + |\mathcal{D}_{N-M}^2 \setminus \mathcal{D}_{N+M+1}^2|) + 2M(|\mathcal{D}_N^1| + |\mathcal{D}_N^2|).$$

We take the expectation under \mathbb{P}^X on both sides. Using Equation (6.2), as well as the fact that $|\mathcal{A}_N|$ is equivalent in L^2 (hence in L^1) to $\frac{|t-s|}{2\pi N^2}$ (recall Equation 5.5), we obtain

$$\mathbb{E}[|S_1 + \dots + S_5|] \leq C'N((NM)^{-1+\varepsilon} + MN^{-2}) + MN^{-1} \xrightarrow{N \rightarrow +\infty} 0,$$

where the last convergence holds for an arbitrary choice of $m \in (0, 1)$ and $\varepsilon \in (0, \frac{1}{2})$.

From this long discussion, it follows that, \mathbb{P} -almost surely,

$$\sum_{k=1}^{+\infty} (M^\vee(\mathcal{D}_k) - M^\vee(\mathcal{D}_{-k})) = \sum_{k=1}^{+\infty} (M^\vee(\mathcal{D}_k^1) - M^\vee(\mathcal{D}_{-k}^1)) + \sum_{k=1}^{+\infty} (M^\vee(\mathcal{D}_k^2) - M^\vee(\mathcal{D}_{-k}^2)).$$

For a point z in the interior of $T_{s,u,t}$ (and outside the range of X), the relation between \mathcal{A}_N and the $\mathcal{A}_k^1, \mathcal{A}_j^2$ has to be shifted by 1:

$$z \in \mathcal{A}_N^1 \iff \exists k \in \mathbb{Z} : z \in \mathcal{A}_k^1 \cap \mathcal{A}_{N-k-1}^2.$$

This explains the apparition of the additional term $M(T_{s,u,t})$ in the Chen relation. Computations similar to the previous ones lead to the equality

$$\begin{aligned} \sum_{k=1}^{+\infty} (M(\mathcal{D}_k \cap T_{s,u,t}) - M(\mathcal{D}_{-k} \cap T_{s,u,t})) &= \sum_{k=1}^{+\infty} (M(\mathcal{D}_k^1 \cap T_{s,u,t}) - M(\mathcal{D}_{-k}^1 \cap T_{s,u,t})) \\ &+ \sum_{k=1}^{+\infty} (M(\mathcal{D}_k^2 \cap T_{s,u,t}) - M(\mathcal{D}_{-k}^2 \cap T_{s,u,t})) + M(T_{s,u,t}). \end{aligned} \quad (6.7)$$

Combining the two equalities gives the desired result. \square

6.3 From weak Chen's relation to pathwise Chen's relation

The goal in this section is to show that, up to modification, a map \mathbb{A} that satisfies the weak Chen relation does satisfies the Chen relation. For this, we need the M-measure of a triangle to be a continuous function of its vertices, and we are able to do this only under the assumption that $\gamma < 2(\sqrt{2} - 1)$.

Let us first recall some terminology for functions of two parameters. For functions of three parameters, we use the same definitions with Δ replaced by $\Delta_3 = \{(s, u, t) \in [0, 1]^3 : s \leq u \leq t\}$.

Definition 6.3.1. *Let X and \tilde{X} be two collections of random variables on the same probability space, both indexed by Δ . We say that they are modifications of each other, or that one is a modification of the other, if for all $w \in \Delta$, almost surely, $X_w = \tilde{X}_w$.*

For instance, the collections \mathbb{A} defined by (5.18) and (6.1) are defined only up to modification.

Definition 6.3.2. *A collection X of random variables indexed by Δ and with values in \mathbb{R}^d is said to be separable (with respect to the class of closed sets) if there exist a countable set I (called the separability set) and a negligible event \mathcal{N} such that for all open set U of Δ and all closed set F of \mathbb{R}^d , the following inclusion holds:*

$$\{\forall w \in U \cap I : X_w \in F\} \setminus \{\forall w \in U : X_w \in F\} \subseteq \mathcal{N}.$$

Our impression is that the terminology of separability, which might have been very commonly used in the past, has gone lost with time. It seems to us that modern introductions to stochastic processes tend to forget about it, to the profit of stronger properties such as continuity or càdlàg property. We will use some results which can be found in [15] and [24]. A discussion of these questions can also be found in [14, Chapter IV, 24-30]. In the first cited text, things are stated for functions from \mathbb{R} to \mathbb{R} , but the results that we use extend without any technical complications to our situation. On the contrary, the framework is much more general in the second cited text. We state these results in the form which is adapted to our framework. The reason why we use separability is that, in order to prove some regularity result, we need to *first* prove the pathwise Chen relation. This relation, since it can rewritten as

$$\forall (s, u, t) \in \Delta_3, \delta \mathbb{A}_{s,u,t} = \mathbb{A}_{s,t} - \mathbb{A}_{s,u} - \mathbb{A}_{u,t} - \varepsilon_{s,u,t} \mathbf{M}(T_{s,u,t}) \in \{0\},$$

clearly follows from the weak one, *provided the family $\delta \mathbb{A}$ is separable*. The following result, due to J.L. Doob, states that any family has a separable modification. Though we will use this result, it is not directly sufficient to us: what we want is not a modification of $\delta \mathbb{A}$ equal to 0, but a modification $\tilde{\mathbb{A}}$ of \mathbb{A} such that the corresponding family $\delta \tilde{\mathbb{A}}$ is separable. To show the existence of such a family is the main purpose of this section.

Lemma 6.3.3 ([15, Theorem 2.4], [24, Theorem 1 in Section III.2]). *Let X be a collection of random variables in the same probability space, indexed by Δ (resp. Δ_3) and with values in \mathbb{R}^d . Then, there exists a separable modification of X .*

We will also need the following characterization of the separability condition.

Lemma 6.3.4 ([24, Lemma 1 in Section III.2]). *A collection $(X_{\mathbf{t}})_{\mathbf{t} \in \Delta_3}$ is separable if and only if there exists a negligible set \mathcal{N} and a countable set $I \subseteq \Delta_3$ such that for all $\omega \in \Omega \setminus \mathcal{N}$ and $\mathbf{t} \in \Delta_3$, the value $X_{\mathbf{t}}(\omega)$ lies in*

$$\bigcap_U \overline{\{X_s(\omega) : s \in U \cap I\}},$$

where U ranges over the open sets in Δ_3 containing \mathbf{t} .

This characterization allows us to prove the following result, which we were unable to find in the literature.

Corollary 6.3.5. *Assume that $(X_{\mathbf{t}})_{\mathbf{t} \in \Delta_3}$ and $(Y_{\mathbf{t}})_{\mathbf{t} \in \Delta_3}$ are separable. Then, $(X_{\mathbf{t}}, Y_{\mathbf{t}})_{\mathbf{t} \in \Delta_3}$ and $(X_{\mathbf{t}} + Y_{\mathbf{t}})_{\mathbf{t} \in \Delta_3}$ are separable.*

Proof. Let I_1, \mathcal{N}_1 (resp. I_2, \mathcal{N}_2) be the sets that appear in the characterization of the separability of X (resp. Y). Let $I = I_1 \cup I_2$, and $\mathcal{N} = \mathcal{N}_1 \cup \mathcal{N}_2$. For all $\mathbf{t} \in \Delta_3$, and U open set in Δ_3 containing \mathbf{t} , for all $\omega \in \Omega \setminus \mathcal{N}$, we know that $X_{\mathbf{t}}(\omega)$ lies in $\overline{\{X_{\mathbf{s}}(\omega) : \mathbf{s} \in U \cap I\}}$ and that $Y_{\mathbf{t}}(\omega)$ lies in $\overline{\{Y_{\mathbf{s}}(\omega) : \mathbf{s} \in U \cap I\}}$. Hence $(X_{\mathbf{t}}, Y_{\mathbf{t}})$ lies in

$$\overline{\{X_{\mathbf{s}}(\omega) : \mathbf{s} \in U \cap I\}} \times \overline{\{Y_{\mathbf{s}}(\omega) : \mathbf{s} \in U \cap I\}} = \overline{\{(X_{\mathbf{s}}(\omega), Y_{\mathbf{s}}(\omega)) : \mathbf{s} \in U \cap I\}}.$$

This allows us to conclude to the first point.

For the second, we use the definition rather than the characterization. Let I, \mathcal{N} be the sets that appear in the definition of the separability of (X, Y) . Let $U \subseteq \Delta_3$ be an open set, and $F \subset \mathbb{R}^d$ be a closed set. Let $\pi : (\mathbb{R}^d)^2 \rightarrow \mathbb{R}^d$ be the map $(x, y) \mapsto x + y$. Then, $\pi^{-1}(F)$ is closed, so that

$$\begin{aligned} \{\forall \mathbf{t} \in U, (X + Y)_{\mathbf{t}}(\omega) \in F\} &= \{\forall \mathbf{t} \in U, (X_{\mathbf{t}}(\omega), Y_{\mathbf{t}}(\omega)) \in \pi^{-1}(F)\} \\ &\subseteq \{\forall \mathbf{t} \in U \cap I, (X_{\mathbf{t}}(\omega), Y_{\mathbf{t}}(\omega)) \in \pi^{-1}(F)\} \cup \mathcal{N} \\ &= \{\forall \mathbf{t} \in U \cap I, (X + Y)_{\mathbf{t}}(\omega) \in F\} \cup \mathcal{N}. \end{aligned}$$

Hence $X + Y$ is separable. \square

In particular, for $\delta \mathbb{A} = (\mathbb{A}_{s,t} - \mathbb{A}_{s,u} - \mathbb{A}_{u,t} - \varepsilon_{s,u,t} \mathbf{M}(T_{s,u,t}))_{(s,u,t) \in \Delta_3}$ to be separable, it suffices that

- $\diamond (\mathbb{A}_{s,t})_{(s,u,t) \in \Delta_3}$ be separable (or equivalently, that $(\mathbb{A}_{s,t})_{(s,t) \in \Delta}$ be separable), and
- $\diamond (\mathbf{M}(T_{s,u,t}))_{(s,u,t) \in \Delta_3}$ be separable.

For the first point, we know from Doob's lemma that $(\mathbb{A}_{s,t})_{(s,t) \in \Delta}$ admits a separable modification. For the second point, the problem is posed in a slightly different way, because $(\mathbf{M}(T_{s,u,t}))_{(s,u,t) \in \Delta_3}$ is defined not as a collection of random variables indexed by Δ_3 , but really as a random function on Δ_3 . Taking a modification of it to ensure its separability would possibly destroy the structure given by the fact that \mathbf{M} is a measure: there is no reason why a modification $(\tilde{m}_{s,u,t})_{(s,u,t) \in \Delta_3}$ of $(\mathbf{M}(T_{s,u,t}))_{(s,u,t) \in \Delta_3}$ would be of the form $\tilde{m}_{s,u,t} = \tilde{\mathbf{M}}(T_{s,u,t})$ for a random measure $\tilde{\mathbf{M}}$.²

²Actually, random measures are entirely characterized by their finite dimensional marginals $\mathbf{M}(A_i)_{i \in I}$ (see [13]), so that the only modifications of \mathbf{M} which are random measures are indistinguishable from \mathbf{M} .

In order to show that the map $(s, u, t) \mapsto \mathbf{M}(T_{s,u,t})$ is separable (not up to modification), the only way that we found is to prove a much stronger result, for which we need γ to be smaller than $2(\sqrt{2} - 1)$. For $\mathbf{z} = (z_1, z_2, z_3) \in (\mathbb{R}^2)^3$, we set $T^{\mathbf{z}}$ the convex hull of the three points z_1, z_2, z_3 . We then define $a : (\mathbb{R}^2)^3 \rightarrow \mathbb{R}^+$ the map given by $a(\mathbf{z}) = \mathbf{M}(T^{\mathbf{z}})$.

Lemma 6.3.6. *For all $\gamma < 2$, the random map a is separable.*

Proof. Let \mathcal{N} be the negligible event on which there exists a compact subset of \mathbb{R}^2 with infinite M-area. Any triangle T is the intersection of a decreasing sequence of triangles with rational vertices, and on the complement of \mathcal{N} , the measure of T is the decreasing limit of the measures of these rational triangles. Hence, a satisfies the separability criterion of Lemma 6.3.4. \square

We will now improve this result and show that the map a is actually continuous, and in fact Hölder continuous, under the additional assumption that $\gamma < 2(\sqrt{2} - 1)$.

Lemma 6.3.7. *Let $\gamma < 2(\sqrt{2} - 1)$. Then, almost surely, the map a is continuous, and locally β -Hölder continuous for any $\beta < 1 - \sqrt{2}\gamma + \frac{\gamma^2}{4}$.*

Proof. We show the result for the restriction of a on the set of triangles contained in the box $[-1, 1]^2$. The global continuity can be deduced by scaling or by a covering argument.

For x on the boundary of $[-1, 1]^2$, $\varepsilon > 0$ and $\theta \in [-\frac{\pi}{2}, \frac{\pi}{2}]$, we denote by $R_{x,\theta}^\varepsilon$ the rectangle with length $4\sqrt{2}$ and width ε , which is centered at x and with angle θ with respect to the x -axis (see Figure 6.2 below).

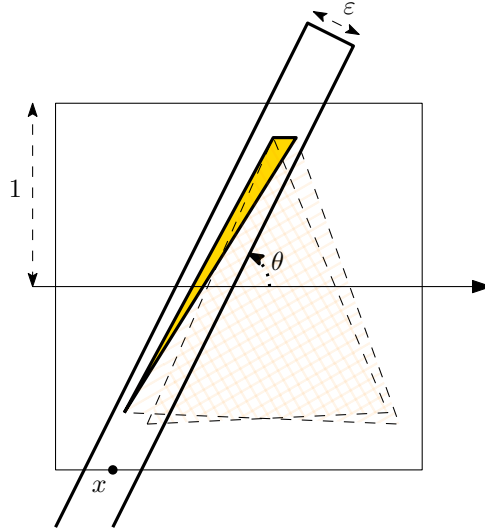

Figure 6.2: Two triangles with close vertices, one of the six triangles that cover their symmetric difference, and a rectangle $R_{x,\theta}^\varepsilon$ that contains this triangle.

Let n be an integer such that $n\varepsilon > 1$. Set

$$I = \{(1, \frac{k}{n}) : |k| \leq n\} \cup \{(\frac{k}{n}, 1) : |k| \leq n\} \quad \text{and} \quad J = \{\frac{k\pi}{2n} : |k| \leq n\}.$$

Consider a triangle T with vertices z_1, z_2, z_3 in $[0, 1]^2$ such that $|z_2 - z_3| \leq \varepsilon$. The line through z_1 and the middle of z_2 and z_3 crosses the boundary of $[-1, 1]^2$ at a point close of a point of I , with an angle close to an element of J . Thus, there exists $(i, j) \in I \times J$ such that T is included on $R_{i,j}^{4\varepsilon}$.

Let us call ε -thin a triangle such as the one that we just considered, that is, a triangle of which two vertices are ε -close. The symmetric difference between two triangles, the vertices of which are pairwise ε -close, is contained in the union of six ε -thin triangles (see Figure 6.2 again). Thus, if $\mathbf{z} = (z_1, z_2, z_3)$ and $\mathbf{z}' = (z'_1, z'_2, z'_3)$ are such that $|\mathbf{z} - \mathbf{z}'| \leq \varepsilon$, then

$$|a(\mathbf{z}) - a(\mathbf{z}')| \leq 6 \max_{(i,j) \in I \times J} R_{i,j}^{4\varepsilon}.$$

We bound this supremum as in the proof of the Kolmogorov criterion, using the fact that the cardinal of $I \times J$ is of order ε^{-2} . For any $\beta < 1 - \sqrt{2}\gamma + \frac{\gamma^2}{4}$ and $q \in [0, \frac{4}{\gamma^2})$,

$$\mathbb{P}(\max_{(i,j) \in I \times J} R_{i,j}^{4\varepsilon} \geq \varepsilon^\beta) \leq \varepsilon^{-\beta q} \mathbb{E} \sum_{(i,j) \in I \times J} (R_{i,j}^{4\varepsilon})^q \leq C \varepsilon^{-2} \varepsilon^{-\beta q} \mathbb{E} [(R_{i,j}^{4\varepsilon})^q] \leq C \varepsilon^{-2-\beta q + \frac{\xi(q)}{2}}.$$

The exponent is minimized by the choice of $q = \frac{2\sqrt{2}}{\gamma}$ (which is less strictly than $\frac{4}{\gamma^2}$), and the bound on β is such that the exponent is then strictly positive. To conclude, we take $\varepsilon = 2^{-n}$ and we apply the Borel–Cantelli lemma. \square

Let us summarize. For $\gamma < 2$, for any map $\mathbb{A} : \Delta \rightarrow \mathbb{R}$ which satisfies the weak Chen relation relative to a continuous path Z , we know that there exists a separable modification of \mathbb{A} of \mathbb{A} , which is easily seen to also satisfy the weak Chen relation. We also know that the map $(s, u, t) \mapsto \mathbb{M}(T^{Z_s, Z_u, Z_t})$ is separable.

Hence, we have obtained the following result.

Proposition 6.3.8. *For all $\gamma < 2$, for all map $\mathbb{A} : \Delta \rightarrow \mathbb{R}$ which satisfies the weak Chen relation relative to a continuous path Z , there exists a modification of \mathbb{A} which is separable and satisfies the (strong) Chen relation relative to Z .*

We will now adress the question of the regularity of such a map \mathbb{A} . Before that, let us remark that the Chen relation, together with Lemma 6.3.7, allows us to deduce Hölder continuity from regularity. We will say a \mathbb{A} is β -regular if there exists a constant C such that for all $(s, t) \in \Delta$, $|\mathbb{A}_{s,t}| \leq C(t - s)^\beta$.

Lemma 6.3.9. *Let $\gamma < 2(\sqrt{2} - 1)$. Let $\mathbb{A} : \Delta \rightarrow \mathbb{R}$ be a map that satisfies the Chen relation relative to a function Z which is α -Hölder continuous, for some $\alpha > 0$. Assume that \mathbb{A} is β -regular. Then, for all β' such that $\beta' \leq \beta$ and $\beta' < (1 - \sqrt{2}\gamma + \frac{\gamma^2}{4})\alpha$, the map \mathbb{A} is β' -Hölder continuous.*

6.4 A Kolmogorov type criterion

The goal of this section is to obtain a Kolmogorov type criterion that applies to our situation, that is a result that allows us to deduce some pathwise regularity (in particular, continuity) of a map $\mathbb{A}(\omega) : \Delta \rightarrow \mathbb{R}$ from regularity of the map $\mathbb{A} : \Delta \rightarrow L^q(\Omega)$.

Proposition 6.4.1. *Assume that $\gamma < \sqrt{2}$, $\alpha \in (\gamma^2(1 + \frac{\gamma^2}{4})^{-2}, 1]$, and $\xi > \frac{1}{2}$. Set*

$$\beta_1 = \begin{cases} \min(\alpha\nu - 1, \xi - \frac{1}{2}) & \text{if } \alpha \geq \gamma^{-2}, \\ \min(2\alpha(1 + \frac{\gamma^2}{4}) - 2\gamma\sqrt{\alpha}, \alpha\nu - \frac{1}{2}, \xi - \frac{1}{2}) & \text{if } \alpha \leq \gamma^{-2}. \end{cases}$$

Let $Z \in C^\alpha$ be a continuous function from $[0, 1]$ to \mathbb{R}^2 , possibly random but independent from \mathbb{M} (say, defined in a probability space Ω^X). Assume that \mathbb{A} is separable and satisfies the weak Chen relation relative to Z , and assume that there exists a positive random variable C_0 on Ω^X such that for all $(s, t) \in \Delta$, \mathbb{P}^X -almost surely, $\|\mathbb{A}_{s,t}\|_{L^2(\Omega^{\mathbb{M}}, \mathbb{P}^{\mathbb{M}})} \leq C_0(t-s)^\xi$.

Then, \mathbb{A} is almost surely β_1 -regular: \mathbb{P} -almost surely, for all $\beta < \beta_1$, there exists C such that for all $(s, t) \in \Delta$,

$$|\mathbb{A}_{s,t}| \leq C(t-s)^\beta.$$

Proof. We write

$$\mathbb{D} = \{s \in [0, 1) : \exists i, j \in \mathbb{N}, s = i2^{-n}\}$$

the set of dyadic numbers. We set $\beta_0 = \alpha\nu - 1$ if $\alpha \geq \gamma^{-2}$, and $\beta_0 = 2\alpha(1 + \frac{\gamma^2}{4}) - 2\gamma\sqrt{\alpha}$ if $\alpha \leq \gamma^{-2}$. In particular, $\beta_1 = \min(\beta_0, \alpha\nu - \frac{1}{2}, \xi - \frac{1}{2})$. We rely on the classical proof of Kolmogorov criterion for rough paths. We follow in particular the proof of Theorem 3.1 in [19] (with $q = 2$), but with some modification. By localization, we can assume that both C_0 and $\|Z\|_{C^\alpha}$ admit polynomial moments of all order.

For all $n \geq 0$, we denote by \mathbb{D}_n the set of integer multiples of 2^{-n} in $[0, 1)$.

We now introduce a few notations for some rectangles and triangles. Figure 6.3 should help understand the notations. For $s \leq t$ and Z equal to either X (a Brownian motion) or Y (an α -Hölder continuous curve), we denote by $T_{s,t}$ the triangle with vertices Z_s, Z_t , and (Z_t^1, Z_s^2) . For $s \leq u \leq t$, we denote (as before) $T_{s,u,t}$ the triangle with vertices Z_s, Z_u and Z_t , and we denote $R_{s,u,t}$ the rectangle $[Z_u^1, Z_t^1] \times [Z_s^2, Z_u^2]$. Finally, we define $R_{s,t,u,v}$ as the rectangle $[Z_s^1, Z_t^1] \times [Z_u^2, Z_v^2]$. Let us recall that $\varepsilon_{s,u,t} \in \{\pm 1\}$ is equal to 1 if the points Z_s, Z_t and Z_u

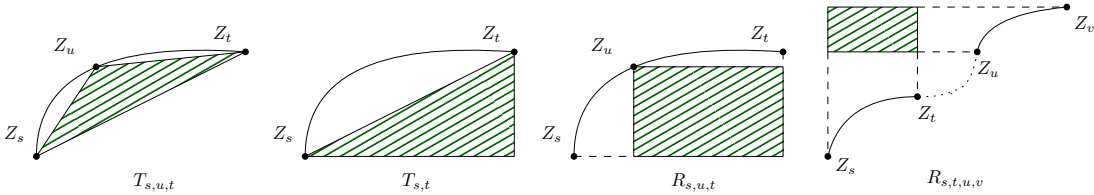

Figure 6.3: The triangles $T_{s,u,t}$ and $T_{s,t}$, and the rectangles $R_{s,u,t}$ and $R_{s,t,u,v}$.

appears in trigonometric order along the boundary of $T_{s,u,t}$. We similarly define $\varepsilon_{s,t}$ as equal to 1 if the points $Z_s, (Z_t^1, Z_s^2)$ and Z_t appears in trigonometric order along the boundary of $T_{s,t}$, and equal to -1 otherwise. In Figure 6.3, $\varepsilon_{s,t} = \varepsilon_{s,u,t} = 1$. These values are such that for all $s \leq u \leq t$,

$$\varepsilon_{s,u,t} \mathbb{M}(T_{s,u,t}) + \varepsilon_{s,t} \mathbb{M}(T_{s,t}) = \varepsilon_{s,u,t} \mathbb{M}(R_{s,u,t}) + \varepsilon_{s,u} \mathbb{M}(T_{s,u}) + \varepsilon_{u,t} \mathbb{M}(T_{u,t}).$$

Besides, $R_{s,u,t} = R_{s,u,u,t}$. We denote

$$\mathcal{A}_{s,t}^Y = \mathbb{A}_{s,t}^Y + \varepsilon_{s,t} \mathbf{M}(T_{s,t}). \quad (6.8)$$

We also set

$$J_{n,n'} = \max_{\substack{i \in \mathbb{D}_n \\ j \in \mathbb{D}_{n'}}} \mathbf{M}(R_{i,i+2^{-n},j,j+2^{-n'}}). \quad (6.9)$$

The second moment of this variable can be estimated as follows:

$$\mathbb{E}[J_{n,n'}^2] \leq \sum_{\substack{i \in \mathbb{D}_n \\ j \in \mathbb{D}_{n'}}} \mathbb{E}[\mathbf{M}(R_{i,i+2^{-n},j,j+2^{-n'}})^2] \leq C \sum_{\substack{i \in \mathbb{D}_n \\ j \in \mathbb{D}_{n'}}} |R_{i,i+2^{-n},j,j+2^{-n'}}|^\nu \leq C 2^{(1-\alpha\nu)(n+n')} \quad (6.10)$$

with $C = \mathbb{E}[\|Z\|_{\mathcal{C}^\alpha}^2]$.

Actually, we obtain a better estimation by looking at the moment of order q of $J_{n,n'}$. We obtain the following bound, the proof of which is postponed to Section 6.5 (Lemma 6.5.5):

$$\mathbb{E}[J_{n,n'}^2] \leq C 2^{-\beta_0(n+n')}. \quad (6.11)$$

For $s < t \in \mathbb{D} = \bigcup_{n \geq 0} \mathbb{D}_n$, we define $s = \tau_0 < \dots < \tau_N = t$ as follows³. Let m be the integer part of $-\log_2(t-s)$ and r be the unique element of $\mathbb{D}_m \cap [s, t)$. Write

$$s = r - \sum_{i=1}^M 2^{-\phi(i)}, \quad t = r + \sum_{i=1}^P 2^{-\psi(i)},$$

with ϕ, ψ two strictly increasing functions from \mathbb{N} to \mathbb{N} with $\phi(1) \geq m+1, \psi(1) \geq m+1$. Such a decomposition always exists. We set $N = M + P$, $\tau_M = r$. For $j \in \{0, \dots, M-1\}$, we set $\tau_j = r - \sum_{i=1}^{M-j} 2^{-\phi(i)}$. For $j \in \{M+1, \dots, M+P\}$, we set $\tau_j = r + \sum_{i=1}^{j-M} 2^{-\psi(i)}$. For each $j \in \{0, \dots, M+P\} \setminus \{M\}$, set n_j such that $\tau_j \in \mathbb{D}_{n_j} \setminus \mathbb{D}_{n_{j-1}}$. Set also $n_M = m$. Then, it is easily seen that $(n_j)_{j \in \{0, M\}}$ is strictly decreasing, whilst $(n_j)_{j \in \{M, M+P\}}$ is strictly increasing. In particular, the sequence $(n_j)_{j \in \{0, M+P\}}$ takes each value at most twice, and takes no value smaller than m . In particular, for any sequence $(a_n)_{n \in \mathbb{N}}$ of positive terms,

$$\sum_{i=0}^N a_{n_i} \leq 2 \sum_{n=m}^{+\infty} a_n.$$

For $u < v \in \mathbb{D}$, we define $u = \sigma_0 < \dots < \sigma_{N'} = t$ and $(n'_j)_{j \in \{0, \dots, N'\}}$ in an identical way, and we set m' the integer part of $-\log_2(v-u)$.

Then, for any $\delta < \frac{\beta_0}{2}$, we claim that $\mathbb{E}[\max_{s < t, u < v} ((t-s)^{-\delta}(v-u)^{-\delta} \mathbf{M}(R_{s,t,u,v}))^2]$ is finite. Indeed, it is bounded above by

$$\mathbb{E} \left[\max_{s < t, u < v} \left(\sum_{i=1}^N \sum_{j=1}^{N'} (t-s)^{-\delta} (v-u)^{-\delta} \mathbf{M}(R_{\tau_{i-1}, \tau_i, \sigma_{i-1}, \sigma_i}) \right)^2 \right],$$

³This sequence τ_0, \dots, τ_N plays the same role as the one defined in [19], though the construction is not exactly the same.

which in turn is not greater than

$$\begin{aligned} \mathbb{E} \left[\max_{s < t, u < v} \left(\sum_{i=1}^N \sum_{j=1}^{N'} 2^{-\delta m} 2^{-\delta m'} J_{n_i, n'_j} \right)^2 \right] &\leq \mathbb{E} \left[\max_{s < t, u < v} 4 \left(\sum_{\substack{n \geq m \\ n' \geq m'}} 2^{\delta(m+m')} J_{n, n'} \right)^2 \right] \\ &\leq 4 \left(\sum_{\substack{n \geq m \\ n' \geq m'}} 2^{\delta(n+n')} \mathbb{E}[J_{n, n'}^2]^{\frac{1}{2}} \right)^2 \leq 4 \left(\sum_{\substack{n \geq m \\ n' \geq m'}} 2^{(\delta - \frac{\beta_0}{2})(n+n')} \right)^2 < +\infty. \end{aligned}$$

We denote by C_M the expectation of which we just proved that it is finite.

Let us now look at $\mathbb{A}_{s,t}^Z$. Remark that

$$\mathbb{E}[|\mathbb{M}(T_{s,t})|^2] \leq C \mathbb{E}^Z[|T_{s,t}|^\nu] = C \frac{\mathbb{E}[|Z_t^1 - Z_s^1|^\nu |Z_t^2 - Z_s^2|^\nu]}{2^\nu} \leq C'(t-s)^{2\alpha\nu},$$

with $C' = \frac{C}{2^\nu} \mathbb{E}[|Z|_{\mathcal{C}^\alpha}^{2\nu}]$, and C the constant of Lemma 5.2.2. Since we assumed $\mathbb{E}[(\mathbb{A}_{s,t}^Z)^2] \leq C(t-s)^{2\xi}$, this implies

$$\mathbb{E}^M[\mathcal{A}_{s,t}^Z] \leq C(t-s)^{2\min(\xi, \alpha\nu)}.$$

Let us define $\mathbb{K}_n = \max_{t \in \mathbb{D}_n} |\mathcal{A}_{t, t+2^{-n}}^Z|$. Then

$$\mathbb{E}^M[\mathbb{K}_n^2] \leq \sum_{t \in \mathbb{D}_n} \mathbb{E}^M[|\mathcal{A}_{t, t+2^{-n}}^Z|^2] \leq C 2^{(1-2\min(\xi, \alpha\nu))n}.$$

We set $s = \tau_0 < \dots < \tau_n = t$ as before. Then, for any $\beta' \in (0, \beta)$ and $\delta \in (\frac{\beta'}{2}, \frac{\beta}{2})$,

$$\begin{aligned} \mathbb{E}^M \left[\max_{s < t \in [0,1]} \left((t-s)^{-\beta'} \mathbb{A}_{s,t}^Z \right)^2 \right] &\leq \mathbb{E}^M \left[\max_{s < t \in [0,1]} \left((t-s)^{-\beta'} \sum_{i=0}^N (\mathbb{A}_{\tau_i, \tau_{i+1}}^Z + \mathbb{M}(R_{s, \tau_i, \tau_{i+1}})) \right)^2 \right] \\ &\leq 2 \mathbb{E}^M \left[\max_{s < t \in [0,1]} \left((t-s)^{-\beta'} \sum_{i=0}^N \mathbb{A}_{\tau_i, \tau_{i+1}}^Z \right)^2 \right] + 2 \mathbb{E}^M \left[\max_{s < t \in [0,1]} \left(\sum_{i=0}^N (t-s)^{-\beta'} \mathbb{M}(R_{s, \tau_i, \tau_{i+1}}) \right)^2 \right] \\ &\leq 8 \mathbb{E}^M \left[\left(\sum_{n=0}^{+\infty} 2^{\beta' n} \mathbb{K}_n \right)^2 \right] \\ &\quad + 8 \mathbb{E}^M \left[\max_{s < t \in [0,1]} \left((t-s)^{-\beta'} \sum_{n=0}^{+\infty} \max_{u \in [s, t]} (s-u)^\delta 2^{-\delta n} (s-u)^{-\delta} 2^{\delta n} \mathbb{M}(R_{s, u, u+2^{-n}}) \right)^2 \right] \\ &\leq 8 \left(\sum_{n=0}^{+\infty} 2^{\beta' n} \mathbb{E}^M[(\mathbb{K}_n)^2]^{\frac{1}{2}} \right)^2 \\ &\quad + 8 \mathbb{E}^M \left[\max_{s < t \in [0,1]} \left(\sum_{n=0}^{+\infty} 2^{(\beta' - \delta)n} 2^{-\delta n} \max_{u \in [s, t]} (s-u)^{-\delta} 2^{\delta n} \mathbb{M}(R_{s, u, u+2^{-n}}) \right)^2 \right] \\ &\leq C \left(\sum_{n=0}^{+\infty} 2^{(\beta' + \frac{1}{2} - \max(\xi, \alpha\nu))n} \right)^2 + 8 \left(\sum_{n=0}^{+\infty} 2^{(\beta' - 2\delta)n} C_M \right)^2 < +\infty. \end{aligned}$$

This proves that, for all $\beta < \beta_1$, \mathbb{P} -almost surely, there exists a constant C such that for all $(s, t) \in \Delta \cap \mathbb{D}^2$, $|\mathbb{A}_{s,t}| \leq C(t-s)^\beta$.

Our assumption is that \mathbb{A} is separable, but with respect to a countable subset I of Δ which we do not know. Let us explain how this general situation can be reduced to the dyadic situation that we treated above. Firstly, I can be replaced by a countable set with a product structure, namely the set of all points of Δ which share each of their coordinates with a point of I . Thus, I is the intersection with Δ of a set of the form $\tilde{\mathbb{D}}^2$, for some countable dense subset $\tilde{\mathbb{D}}$ of $[0, 1]$. Then, we can write $\tilde{\mathbb{D}}$ as an infinite union $\bigcup_{N \in \mathbb{N}} \tilde{\mathbb{D}}_N$, in a way that mimics the decomposition of \mathbb{D} that we used above, namely in such a way that the points of $\tilde{\mathbb{D}}_N$ are close enough to being evenly spaced for our arguments to work.

This being taken into account, the separability of \mathbb{A} allows us to conclude that for all $(s, t) \in \Delta$, $|\mathbb{A}_{s,t}| \leq C(t-s)^\beta$ and the proposition is proved. \square

Corollary 6.4.2. *Assume that $\gamma < \sqrt{2}$ and Y is α -Hölder continuous for $\alpha > \frac{1}{2}(1 - \frac{\gamma^2}{4})^{-1}$. Then \mathbb{A}^Y admits a separable modification which satisfies the Chen relation and which is β -regular for all*

$$\beta < \beta_0 = \begin{cases} \alpha\nu - 1 & \text{if } \alpha \geq \gamma^{-2}, \\ 2\alpha(1 + \frac{\gamma^2}{4}) - 2\gamma\sqrt{\alpha} & \text{if } \alpha \in [\frac{3-2\sqrt{2}}{2}\gamma^{-2}, \gamma^{-2}] \\ \alpha\nu - \frac{1}{2} & \text{if } \alpha \leq \frac{3-2\sqrt{2}}{2}\gamma^{-2}. \end{cases}$$

If $\gamma < 2(\sqrt{2} - 1)$, this modification is β' -Hölder continuous for $\beta' = \min((1 - \sqrt{2}\gamma + \frac{\gamma^2}{4})\alpha, \beta)$.

Proof. The condition $\alpha > \frac{1}{2}(1 - \frac{\gamma^2}{4})^{-1}$ implies $\alpha > \gamma^2(1 + \frac{\gamma^2}{4})^{-2}$. Corollary 6.1.4 and Lemma 6.2.2 ensure that we can take $\xi = \alpha\nu - \varepsilon$ for any $\varepsilon > 0$ in the conditions of Proposition 6.4.1. This suffices to conclude to the first family of properties. For the Hölder regularity when $\gamma < 2(\sqrt{2} - 1)$, we also use Proposition 6.3.8 and then Lemma 6.3.9. \square

For the equivalent result in the Brownian situation, we need to obtain a scaling relation for \mathbb{A}^X . It is obtained from the scaling properties of the Brownian motion and the measure \mathbb{M} .

Lemma 6.4.3. *Assume that $\gamma < \sqrt{4/3}$. There exists an increasing family of events $(E_n)_{n \geq 1}$ on Ω^X , with $\mathbb{P}^X(E_n) \rightarrow 1$, and a family of constants $(C_n)_{n \geq 1}$, such that for all $n \geq 1$, for all $(s, t) \in \Delta$,*

$$\mathbb{E}[\mathbb{1}_{E_n} \mathbb{A}_{s,t}^2] \leq C_n(t-s)^\nu.$$

Proof. For N a positive integer and $(s, t) \in \Delta$, we set

$$\mathcal{D}_{N,s,t} = \{z \in \mathbb{R}^2 : \theta_{X_{[s,t]}}(z) \geq N\}, \quad \mathcal{D}_{-N,s,t} = \{z \in \mathbb{R}^2 : \theta_{X_{[s,t]}}(z) \leq -N\}.$$

Assume first that K is given by $K(z, w) = \log_+(|z - w|^{-1})$ and write \mathbb{M}_0 the associated measure. Let E_n be the event $E_n = \{\forall (s, t) \in \Delta, t - s < \frac{1}{n} \implies |X_t - X_s| \leq \frac{1}{2}\}$. Clearly, $\mathbb{P}(E_n) \rightarrow 1$. For $n \geq 1$ and $(s, t) \in \Delta$ with $t - s < \frac{1}{n}$, using the exact scale invariance of \mathbb{M}_0 (see Section 6.5), then Cauchy-Schwarz inequality, then scaling properties of the Brownian motion,

we get

$$\begin{aligned}
\mathbb{E}^X[\mathbb{1}_{E_n} \mathbb{E}^M[\mathbb{A}_{s,t}^2]] &= \mathbb{E}^X[\mathbb{1}_{E_n} \mathbb{E}^M[(\sum_{N=1}^{+\infty} (\mathbb{M}_0(\mathcal{D}_{N,s,t}) - \mathbb{M}_0(\mathcal{D}_{-N,s,t})))^2]] \\
&= (t-s)^\nu \mathbb{E}^X[\mathbb{1}_{E_n} \mathbb{E}^M[(\sum_{N=1}^{+\infty} (\mathbb{M}_0((t-s)^{-\frac{1}{2}} \mathcal{D}_{N,s,t}) - \mathbb{M}_0((t-s)^{-\frac{1}{2}} \mathcal{D}_{-N,s,t})))^2]] \\
&\leq (t-s)^\nu \mathbb{E}[(\sum_{N=1}^{+\infty} (\mathbb{M}_0((t-s)^{-\frac{1}{2}} \mathcal{D}_{N,s,t}) - \mathbb{M}_0((t-s)^{-\frac{1}{2}} \mathcal{D}_{-N,s,t})))^2]] \\
&= (t-s)^\nu \mathbb{E}[(\sum_{N=1}^{+\infty} (\mathbb{M}_0(\mathcal{D}_{N,0,1}) - \mathbb{M}_0(\mathcal{D}_{-N,0,1})))^2]],
\end{aligned}$$

and we know the latter sum to be convergent. For $t-s \geq \frac{1}{n}$, we can simply say that

$$\mathbb{E}^X[\mathbb{1}_{E_n} \mathbb{E}^M[\mathbb{A}_{s,t}^2]] \leq (t-s)^\nu n^\nu \mathbb{E}^X[\mathbb{1}_{E_n} \mathbb{E}^M[\mathbb{A}_{s,t}^2]],$$

so that the constant

$$C_n = \max\left(\mathbb{E}\left[\left(\sum_{N=1}^{+\infty} (\mathbb{M}_0(\mathcal{D}_{N,0,1}) - \mathbb{M}_0(\mathcal{D}_{-N,0,1}))\right)^2\right], n^\nu \mathbb{E}^X[\mathbb{1}_{E_n} \mathbb{E}^M[\mathbb{A}_{s,t}^2]]\right)$$

works.

If K is now given by $K(s,t) = \log_+(|t-s|^{-1}) + C$ for a constant C , the measure \mathbb{M}_C associated is given by $\mathbb{M}_C(A) = e^{\Omega - \frac{1}{2}\mathbb{E}[\Omega^2]} \mathbb{M}_0(A)$, for Ω a centered Gaussian variable independent from \mathbb{M}_0 and with variance C . We conclude to this case from the previous one.

Finally, for the general case $K(s,t) = \log_+(|t-s|^{-1}) + g(x,y)$, let us recall that we assumed g to be bounded. Let C be its supremum. Then, the Kahane convexity inequalities (see for example [22], Appendix A) implies that $\mathbb{A}_{s,t}$ computed with \mathbb{M} has a second moment which is less than the one computed with \mathbb{M}_C . This concludes the proof. \square

Corollary 6.4.4. *Assume $\gamma < 2(\sqrt{2}-1)$. Let X be a Brownian motion independent from \mathbb{M} . Then, \mathbb{A}^X admits a modification which satisfies the Chen relation, is β -regular for all $\beta < \min(\frac{1}{2} - \frac{\gamma^2}{4}, 1 + \frac{\gamma^2}{4} - \sqrt{2}\gamma)$, and β -Hölder continuous for all $\beta < \frac{1}{2}(1 + \frac{\gamma^2}{4} - \sqrt{2}\gamma)$.*

Proof. The condition $\alpha > \gamma^2(1 + \frac{\gamma^2}{4})^{-2}$ in Proposition 6.4.1 is satisfied, for $\gamma < 2(\sqrt{2}-1)$, provided the Hölder exponent α is chosen sufficiently close to $\frac{1}{2}$. Lemmas 6.2.2 and 6.4.3 ensure that the hypothesis of Proposition 6.4.1 are fulfilled with $\xi = \frac{\nu}{2}$, and for all $\alpha < \frac{1}{2}$. We are on the case $\alpha < \gamma^{-2}$. The conclusion of Proposition 6.4.1, together with Proposition 6.3.8 and Lemma 6.3.9, gives the corollary. \square

Remark 6.4.5. *For $\gamma < 2(\sqrt{2}-1)$, the almost surely defined continuous extension of $\mathbb{A}_{s,t}^X$ allows us to define $\mathbb{A}_{\sigma,\tau}^X$ for any random time σ, τ . It thus allows us to define $\mathbb{A}_{s,t}^X$ for any process \mathcal{X} obtained as a reparametrization of X , hence in particular for the Liouville Brownian motion, defined in [22] or in [4].*

Remark 6.4.6. *It is plausible that the Hölder regularity is actually higher when one considers the Liouville Brownian motion \mathcal{X} instead of X . Also, it is possible that a Hölder continuous curve Y admits a reparametrization \mathcal{Y} such that $\mathbb{A}^{\mathcal{Y}}$ has a higher regularity than \mathbb{A}^Y . Such a reparametrization should be obtained by ‘freezing’ Y when it lies on the set where \mathbb{M} is large and by ‘speeding it up’ when it is far from it.*

6.5 Uniform estimates in L^q

During the proof of Proposition 6.4.1, there is a point that was left aside, about the estimation of $\mathbb{E}[J_{n,n'}^2]$, where $J_{n,n'}$ is defined by (6.9). The goal in this section is to prove the estimation (6.11). Our starting point is the following combination of an elementary comparison of a maximum and a sum, and Hölder inequality: for all $q \in [2, \frac{4}{\gamma^2})$,

$$\mathbb{E}[J_{n,n'}^2] \leq \mathbb{E}[J_{n,n'}^q]^{\frac{2}{q}} \leq 2^{n+n'} \max \{ \mathbb{E}[\mathbb{M}(R_{i,i+2^{-n},j,j+2^{-n'}})^q]^{\frac{2}{q}} : i \in \mathbb{D}_n, j \in \mathbb{D}_{n'} \}.$$

What we need is thus a good uniform bound on the q -th moment of the \mathbb{M} -measure of a small rectangle. To do this, we study the way in which the \mathbb{M} -measure of a rectangle is affected by a smooth transformation of the plane, and prove that a rectangle of given area can be nicely and smoothly sent into a fixed square. Once this is done, we know that the \mathbb{M} -measure is not too different from the \mathbb{M} -measure of a subset of the fixed square, which gives us what we needed.

In order to understand how the measure \mathbb{M} is affected by a smooth transformation of the plane, it is useful to think about its informal definition (5.1). Pushing this expression forward by a diffeomorphism affects it in two ways: it changes the correlation structure of the field in the exponential, and introduces a Jacobian. In order to control the change in the correlation structure of the field, we will use Kahane’s convexity inequalities, which compare the multiplicative Gaussian chaoses associated to two kernels which do not differ too much. The crucial point for us is that our transformation of the plane does not bring too far apart two points that were initially close. We must therefore control something like its Lipschitz norm. On the other hand, we also need the (inverse) Jacobian term that appears not to explode. How to map a possibly long and thin rectangle into a square in a way that satisfies these constraints is explained by Lemma 6.5.1.

Lemma 6.5.1. *Let $n \geq 1$ be an integer. There exists a function $\phi : [0, 2^n] \times [0, 2^{-n}] \rightarrow [0, 10]^2$ that is injective, 10-Lipschitz continuous, piecewise \mathcal{C}^1 , with Jacobian bounded below by $\frac{1}{10}$.*

Proof. Let us split the rectangle $R = [0, 2^n] \times [0, 2^{-n}]$ into 2^n rectangles R_1, \dots, R_{2^n} , each of which have sides of length 1 and 2^{-n} . We map each rectangle to a domain shaped like an integral symbol (see Figure 6.4 below). For this, we decompose each R_i into $L_i \sqcup R'_i \sqcup U_i$, where L_i and U_i are the two rectangles of width $2^{-n}\frac{\pi}{2}$ at the extremities. We parametrize each of them linearly by $[0, 2^{-n}\frac{\pi}{2}] \times [0, 2^{-n}]$, and we map them to a quarter of an annulus by $\phi : (2^{-n}x, 2^{-n}y) \mapsto (2^{-n}(y+1)\sin(x), 2^{-n}(y+1)\cos(x))$. This map (defined on the given rectangle) is 10-Lipschitz, and its Jacobian determinant is uniformly bounded below by $\frac{1}{10}$. We finally glue the pieces together, as shown by the following figure (Figure 6.5).

This concludes the proof. □

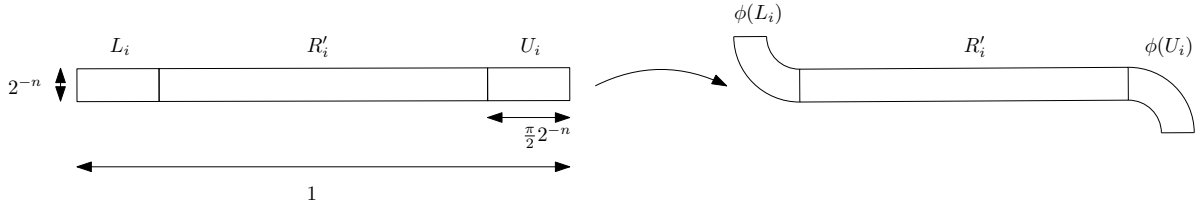

Figure 6.4: Mapping of one rectangle.

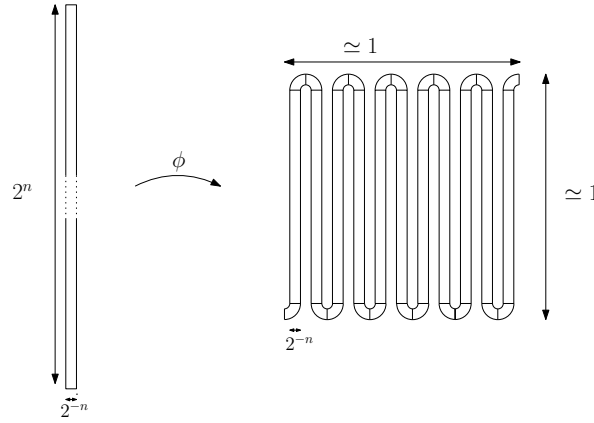

Figure 6.5: gluing the pieces.

As explained at the beginning of the section, we will make use of Kahane’s convexity inequality, which we state in a version adapted to our framework. The proof, which is a notoriously hard one, can be found in [29]. We assume that M and M' are two multiplicative gaussian chaos with kernels K and K' (and with the same intermittency parameter γ).

Proposition 6.5.2. *Let $F : \mathbb{R}_+ \rightarrow \mathbb{R}$ be some convex function such that*

$$\forall x \in \mathbb{R}_+, |F(x)| \leq M(1 + |x|^\beta),$$

for some positive constants M, β . Assume that $K(z, w) \leq K'(z, w) + C$ for some $C \geq 0$. Then, for all compact set A ,

$$\mathbb{E}[F(M(A))] \leq \mathbb{E}[F(e^{\sqrt{C}-\frac{C}{2}} M'(A))].$$

We can now prove the following lemma.

Lemma 6.5.3. *For all $q \in [1, \frac{4}{\gamma^2})$, there exists a constant C such that for all rectangle R with sides of length $l, L \leq 1$,*

$$\mathbb{E}[M(R)^q] < C|R|^{\frac{\xi(q)}{2}},$$

where ξ is the so-called structure exponent $\xi(q) = (2 + \frac{\gamma^2}{2})q - \frac{\gamma^2}{2}q^2$.

Proof. If we restrict ourselves to squares, the result is standard and follows simply from scaling relations (see for example Theorem 2.14 in [40]). We will reduce the more general case of rectangles to the case of squares thanks to the previous lemma.

First, we fix m and m' such that $l \in [2^{-m-1}, 2^{-m}]$, $L \in [2^{-m'-1}, 2^{-m'}]$ where l and L are the length of the sides of R (with $L > l$). Let ϕ be the map resulting from an application of Lemma 6.5.1 with $n = m' - m$, properly rotated, translated, and conjugated by a homothety, so that it maps R to a square S of area $100|R|$.

Let K_k be an increasing sequence of continuous covariance kernels converging pointwise towards K . Let also $(X_k)_{k \geq 1}$ be a sequence a continuous centered Gaussian field with covariance kernels $(K_k)_{k \geq 1}$, and \mathbf{M}_k the associated measure, given by

$$\mathbf{M}_k = e^{\gamma X_k - \frac{\gamma^2}{2} \mathbb{E}^{\mathbf{M}}[X_k^2]} d\lambda.$$

Let also $\phi_*(X_k)$ be the centered Gaussian field defined on $\phi(R)$ by $\phi_*(X_k)_u = (X_k)_{\phi^{-1}(u)}$. As explained at the beginning of this section, the push-forward of \mathbf{M}_k by ϕ and the exponential of the Gaussian field $\phi_*(X_k)$ differ by a Jacobian term.

We denote by $J : R \rightarrow \mathbb{R}_+^*$ the absolute value of the Jacobian determinant of ϕ , and by \mathbf{M}_k^ϕ the random measure on $\phi(R)$ given by

$$d\mathbf{M}_k^\phi(u) = \exp\left(\gamma(X_k)_{\phi^{-1}(u)} - \frac{\gamma^2}{2} \mathbb{E}[(X_k)_{\phi^{-1}(u)}^2]\right) d\lambda(u).$$

Observe that the push-forward of the measure \mathbf{M}_k by ϕ , that we denote by $\phi_*(\mathbf{M}_k)$, is related to \mathbf{M}_k^ϕ by the relation

$$d\phi_*(\mathbf{M}_k)(u) = J(\phi^{-1}(u))^{-1} d\mathbf{M}_k^\phi(u).$$

Then

$$\mathbf{M}_k(R) = \phi_*(\mathbf{M}_k)(\phi(R)) \leq 10\mathbf{M}_k^\phi(\phi(R)),$$

from which it follows that

$$\mathbb{E}^{\mathbf{M}}[\mathbf{M}_k(R)^q] \leq 10^q \mathbb{E}^{\mathbf{M}}[\mathbf{M}_k^\phi(\phi(R))^q].$$

Let us now check that we can apply Kahane's inequality.

For any pair of points $z, w \in R$, $|\phi(z) - \phi(w)| \leq 10|z - w|$. Hence, $\log(|z - w|^{-1}) \leq \log(|\phi(z) - \phi(w)|^{-1}) + \log(10)$. It follows that there a constant C such that for any $z, w \in R$, $K(z, w) \leq K(\phi(z), \phi(w)) + C$. We denote by \tilde{K}_k the kernel of $\phi_*(X_k)$. For any $u, v \in \phi(R)$,

$$\tilde{K}_k(u, v) = K_k(\phi^{-1}(u), \phi^{-1}(v)) \leq K(\phi^{-1}(u), \phi^{-1}(v)) \leq K(u, v) + C,$$

for a constant C which we allow to vary from line to line. We now apply Kahane convexity inequality, and we deduce that

$$\mathbb{E}^{\mathbf{M}}[\mathbf{M}_N(R)^q] \leq 10^q \mathbb{E}^{\mathbf{M}}[\phi_*(\mathbf{M}_N)(\phi(R))^q] \leq C \mathbb{E}^{\mathbf{M}}[\mathbf{M}(\phi(R))^q] \leq C \mathbb{E}^{\mathbf{M}}[\mathbf{M}(S)^q].$$

for some constant C . The theory of Gaussian multiplicative chaos ensures that $\mathbb{E}^{\mathbf{M}}[\mathbf{M}_N(R)^q]$ converges toward $\mathbb{E}^{\mathbf{M}}[\mathbf{M}(R)^q]$, so that

$$\mathbb{E}^{\mathbf{M}}[\mathbf{M}(R)^q] \leq C \mathbb{E}^{\mathbf{M}}[\mathbf{M}(S)^q] \leq C|S|^{\frac{\xi(q)}{2}} \leq C|R|^{\frac{\xi(q)}{2}}.$$

This concludes the proof. \square

Remark 6.5.4. We think that Lemma 6.5.1 can be extended to general measurable sets, from which Lemma 6.5.5 would also extend to general set. We are even more strongly convinced that Lemma 6.5.5 holds in such a generality, but we miserably failed to prove it despite a tremendous quantity of effort put into it.

The author discovered the paper [49] after writing the solution presented here. It is possible that the general result can be deduced from the estimates found in this paper.

Finally, we can prove the following, with the notation of Proposition 6.4.1.

Lemma 6.5.5. *There exists a constant C such that for all integers n, n' ,*

$$\mathbb{E}[J_{n,n'}^2] \leq C2^{-\beta_0(n+n')}.$$

Proof. From the discussion at the beginning of the section, we know that it suffices to show that, for some $q \in [2, \frac{4}{\gamma^2})$, and $C > 0$, for all $n \in \mathbb{N}$,

$$\max \left\{ \mathbb{E}[\mathbb{M}(R_{i,i+2^{-n},j,j+2^{-n'}})^q]^{\frac{2}{q}} : i \in \mathbb{D}_n, j \in \mathbb{D}_{n'} \right\} \leq C2^{-(n+n')}2^{-\beta_0(n+n')}.$$

From Lemma 6.5.3, for all $q \in [1, \frac{4}{\gamma^2})$, there exists C such that

$$\mathbb{E}[\mathbb{M}(R_{i,i+2^{-n},j,j+2^{-n'}})^q]^{\frac{2}{q}} \leq C|R_{i,i+2^{-n},j,j+2^{-n'}}|^{\frac{\xi(q)}{q}} = C2^{-(n+n')\frac{\xi(q)}{q}}.$$

For $\alpha \geq \frac{1}{\gamma^2}$, the bound is optimal at $q = 2$. For $\alpha \in (\frac{\gamma^2}{4}, \frac{1}{\gamma^2}]$, the bound is optimal at $q = \frac{2}{\gamma\sqrt{\alpha}} \in [2, \frac{4}{\gamma^2})$, and we get

$$\mathbb{E}^{\mathbb{M}}[J_{n,n'}^2] \leq C2^{(2\gamma\sqrt{\alpha}-2\alpha-\frac{\alpha\gamma^2}{2})(n+n')} = C2^{-\beta_0(n+n')}. \quad (6.12)$$

This concludes the proof. □

Remark 6.5.6. *As opposed to a more classical situation, the optimal bound is not obtained by taking q ‘as large as possible’. This is due to the non-linearity of the map $q \mapsto \xi(q)$. It would be interesting to know if the bound given by Lemma 6.5.5 can be improved.*

Bibliography

- [1] S. Albeverio and S. Kusuoka. A basic estimate for two-dimensional stochastic holonomy along Brownian bridges. *J. Funct. Anal.*, 127(1):132–154, 1995.
- [2] M. Antoine, A. Comtet, J. Desbois, and S. Ouvry. Magnetic fields and Brownian motion on the 2-sphere. *Journal of Physics A: Mathematical and General*, 24(11):2581–2586, jun 1991.
- [3] T.F. Banchoff and W.F. Pohl. A generalization of the isoperimetric inequality. *J. Differential Geom.*, 6(2):175–192, 12 1971.
- [4] N. Berestycki. Diffusion in planar Liouville quantum gravity. *Ann. Inst. Henri Poincaré Probab. Stat.*, 51(3):947–964, 2015.
- [5] N. Berestycki. Introduction to the Gaussian free field and Liouville quantum gravity. 2016.
- [6] J. Bertoin and W. Werner. Asymptotic windings of planar Brownian motion revisited via the Ornstein- Uhlenbeck process. In *Séminaire de Probabilités XXVIII*, pages 138–152. Berlin: Springer, 1994.
- [7] J. Bertoin and W. Werner. Stable windings. *The Annals of Probability*, 24(3):1269 – 1279, 1996.
- [8] H. Boedihardjo and X. Geng. Simple piecewise geodesic interpolation of simple and Jordan curves with applications. *Constr. Approx.*, 42(1):161–180, 2015.
- [9] R. Chen and L.A. Shepp. On the sum of symmetric random variables. *Amer. Statist.*, 37(3):237, 1983.
- [10] P. Cheridito. Mixed fractional Brownian motion. *Bernoulli*, 7(6):913–934, 2001.
- [11] A. Comtet, J. Desbois, and S. Ouvry. Winding of planar Brownian curves. *Journal of Physics A: Mathematical and General*, 23(15):3563–3572, aug 1990.
- [12] B. Dacorogna and J. Moser. On a partial differential equation involving the jacobian determinant. *Annales de l’I.H.P. Analyse non linéaire*, 7(1):1–26, 1990.
- [13] D. J. Daley and D. Vere-Jones. *An introduction to the theory of point processes. Vol. II. Probability and its Applications (New York)*. Springer, New York, second edition, 2008. General theory and structure.

- [14] C. Dellacherie and P.-A. Meyer. *Probabilities and potential*, volume 29 of *North-Holland Mathematics Studies*. North-Holland Publishing Co., Amsterdam-New York, 1978.
- [15] J. L. Doob. *Stochastic processes*. Wiley Classics Library. John Wiley & Sons, Inc., New York, 1990. Reprint of the 1953 original, A Wiley-Interscience Publication.
- [16] W. Feller. *An introduction to probability theory and its applications. Vol II. 2nd ed.* John Wiley & Sons, Hoboken, NJ, 1971.
- [17] J. Franchi. Théorème des résidus asymptotique pour le mouvement brownien sur une surface riemannienne compacte. (Asymptotic residue theorem for the Brownian motion on a compact Riemannian surface). *Ann. Inst. Henri Poincaré, Probab. Stat.*, 27(4):445–462, 1991.
- [18] J. Franchi. Enroulements asymptotiques du mouvement brownien autour de lacets dans une variété riemannienne compacte de dimension 3. *Stochastic Processes Appl.*, 52(2):251–272, 1994.
- [19] P. K. Friz and M. Hairer. *A course on rough paths*. Universitext. Springer, Cham, second edition, 2020. With an introduction to regularity structures.
- [20] P. K. Friz and N. B. Victoir. *Multidimensional stochastic processes as rough paths. Theory and applications.*, volume 120. Cambridge University Press, 2010.
- [21] C. Garban and J. Ferreras. The expected area of the filled planar Brownian loop is $\pi/5$. *Communications in mathematical physics*, 264(3):797–810, 2006.
- [22] C. Garban, R. Rhodes, and V. Vargas. Liouville Brownian motion. *Ann. Probab.*, 44(4):3076–3110, 2016.
- [23] D. Geman, J. Horowitz, and J. Rosen. A local time analysis of intersections of Brownian paths in the plane. *Ann. Probab.*, 12(1):86–107, 1984.
- [24] I. I. Gikhman and A. V. Skorokhod. *The theory of stochastic processes. I.* Classics in Mathematics. Springer-Verlag, Berlin, 2004. Translated from the Russian by S. Kotz, Reprint of the 1974 edition.
- [25] J. H. Hannay. Path-linking interpretation of Kirchhoff diffraction. *Proc. Roy. Soc. London Ser. A*, 450(1938):51–65, 1995.
- [26] J H Hannay. The correlated linking numbers of a Brownian loop with two arbitrary curves. *Journal of Physics A: Mathematical and Theoretical*, 52(49):495201, nov 2019.
- [27] J. H. Hannay. Winding number correlation for a Brownian loop in a plane. *Journal of Physics A: Mathematical and Theoretical*, 52(6):065001, jan 2019.
- [28] O. Johnson and R. Samworth. Central limit theorem and convergence to stable laws in mallows distance. *Bernoulli*, 11(5):829–845, 2005.
- [29] J.P. Kahane. Sur le chaos multiplicatif. (On multiplicative chaos). *Ann. Sci. Math. Qué.*, 9:105–150, 1985.

- [30] J.-F. Le Gall. Sur la saucisse de Wiener et les points multiples du mouvement brownien. *Ann. Probab.*, 14(4):1219–1244, 1986.
- [31] J.-F. Le Gall. Some properties of planar Brownian motion. In *École d'Été de Probabilités de Saint-Flour XX—1990*, volume 1527 of *Lecture Notes in Math.*, pages 111–235. Springer, Berlin, 1992.
- [32] J.-F. le Gall and M. Yor. Etude asymptotique des enlacements du mouvement Brownien autour des droites de l'espace. *Probab. Theory Relat. Fields*, 74:617–635, 1987.
- [33] J.-F. le Gall and M. Yor. Enlacements du mouvement brownien autour des courbes de l'espace. *Transactions of the American Mathematical Society*, 317(2):687–722, 1990.
- [34] T. Lévy. Yang-Mills measure on compact surfaces. *Mem. Amer. Math. Soc.*, 166(790):xiv+122, 2003.
- [35] T. Lévy. Two-dimensional Markovian holonomy fields. *Astérisque*, (329):172, 2010.
- [36] T. J. Lyons, M. Caruana, and T. Lévy. *Differential equations driven by rough paths*, volume 1908 of *Lecture Notes in Mathematics*. Springer, Berlin, 2007. Lectures from the 34th Summer School on Probability Theory held in Saint-Flour, July 6–24, 2004, With an introduction concerning the Summer School by Jean Picard.
- [37] R. Mansuy and M. Yor. *Aspects of Brownian motion*. Universitext. Springer-Verlag, Berlin, 2008.
- [38] J. Moser. On the volume elements on a manifold. *Trans. Am. Math. Soc.*, 120:286–294, 1965.
- [39] S. Ouvry. Anyon model, axial anomaly and planar Brownian winding. *Nuclear Physics B - Proceedings Supplements*, 18(2):250–258, 1991.
- [40] R. Rhodes and V. Vargas. Gaussian multiplicative chaos and applications: a review. *Probab. Surv.*, 11:315–392, 2014.
- [41] R. Rhodes and V. Vargas. Gaussian multiplicative chaos and Liouville quantum gravity. In *Stochastic processes and random matrices. Lecture notes of the Les Houches summer school. Volume 104, Les Houches, France, July 6–31, 2015*, pages 548–577. Oxford University Press, 2017.
- [42] I. Sauzedde. Integration and stochastic integration in gaussian multiplicative chaos, 2021. [arXiv:2105.01232](https://arxiv.org/abs/2105.01232).
- [43] I. Sauzedde. Lévy area without approximation. 2021. [arXiv:2101.03992](https://arxiv.org/abs/2101.03992).
- [44] I. Sauzedde. Planar brownian motion winds evenly along its trajectory, 2021. [arXiv:2102.12372](https://arxiv.org/abs/2102.12372).
- [45] Z. Shi. Windings of Brownian motion and random walks in the plane. *The Annals of Probability*, 26(1):112–131, 1998.

- [46] F. Spitzer. Some theorems concerning 2-dimensional Brownian motion. *Trans. Am. Math. Soc.*, 87:187–197, 1958.
- [47] W. Werner. Sur les points autour desquels le mouvement brownien plan tourne beaucoup. *Probability Theory and Related Fields*, 99(1):111–144, 1994.
- [48] W. Werner. Formule de Green, lacet brownien plan et aire de Lévy. *Stochastic Processes Appl.*, 57(2):225–245, 1995.
- [49] M. D. Wong. Universal tail profile of Gaussian multiplicative chaos. *Probab. Theory Related Fields*, 177(3-4):711–746, 2020.
- [50] M. Yor. Loi de l'indice du lacet Brownien, et distribution de Hartman-Watson. *Z. Wahrscheinlichkeitstheor. Verw. Geb.*, 53:71–85, 1980.
- [51] L. C. Young. An inequality of the Hölder type, connected with Stieltjes integration. *Acta Mathematica*, 67(none):251 – 282, 1936.