



HAL
open science

Heterogeneous wireless networks coexistence techniques

Ali Mamadou Mamadou

► **To cite this version:**

Ali Mamadou Mamadou. Heterogeneous wireless networks coexistence techniques. Networking and Internet Architecture [cs.NI]. Université Clermont Auvergne, 2022. English. NNT : 2022UCFAC015 . tel-03869618

HAL Id: tel-03869618

<https://theses.hal.science/tel-03869618v1>

Submitted on 24 Nov 2022

HAL is a multi-disciplinary open access archive for the deposit and dissemination of scientific research documents, whether they are published or not. The documents may come from teaching and research institutions in France or abroad, or from public or private research centers.

L'archive ouverte pluridisciplinaire **HAL**, est destinée au dépôt et à la diffusion de documents scientifiques de niveau recherche, publiés ou non, émanant des établissements d'enseignement et de recherche français ou étrangers, des laboratoires publics ou privés.



PhD thesis

Heterogeneous wireless networks coexistence techniques

By

Ali MAMADOU MAMADOU

Jury composition:

- Benoit HILT, *reviewer*, associate Professor at University of Haute-Alsace, France;
- Kinda KHAWAM, *reviewer*, associate Professor at University of Versailles, France;
- Nathalie MITTON, *examiner*, full Professor at Inria Lille Nord Europe, France;
- Oussama HABACHI, *examiner*, full Professor at Clermont Auvergne University, France;
- Vincent BARRA, *examiner*, full Professor at Clermont Auvergne University, France;
- Gérard CHALHOUB, *supervisor*, associate Professor at Clermont Auvergne University, France.

A thesis submitted in fulfillment of the requirements of PhD degree in the
LIMOS UMR 6158 CNRS Laboratory,
Doctoral school of science for engineering,
Clermont Auvergne University, France.

March 21, 2022

Heterogeneous wireless networks coexistence techniques

Ali MAMADOU MAMADOU
supervisor: **Gerard CHALHOUB**

March 21, 2022

DEDICATION

This work is dedicated with *love and respect* to my family: my dad Mamadou Mary, my mom Mariama, my fiancée Amina, my sisters Zeiname, Fadji, Kadi, Amballam, Safia, and my brothers Maïnta, Boukar, Issoufou, Ibrahim, Idi kolo, Bazoum, Garba,

Ali MAMADOU MAMADOU
March 21, 2022

ACKNOWLEDGMENTS

I received a lot of support and assistance throughout the preparation of this dissertation.

First, I would like to thank my supervisor, Gerard Chalhoub, whose expertise was invaluable in formulating the research questions and methodology. Your insightful feedback pushed me to sharpen my thinking and brought my work to a higher level. I would like also to thank all the jury members for their time in voluntarily reviewing and evaluating this dissertation as well as their relevant feedback.

I would like to acknowledge my colleagues from my LIMOS laboratory (in office N°C6 of the IUT Clermont Auvergne, telecom & network department) for their wonderful collaboration and discussions. I would particularly like to single out, Der Sylvestre, G. Sidibé, Mouna Karoui, and Ibrahim Sammour for the help and stimulating discussions to further my research.

In addition, I would like to thank my parents (Mom, Dad) for their wise counsel and sympathetic ear, without whom I would be able to go so far. I would like to thank my fiancée, sisters, and brothers for being always there for me.

I could not have completed this dissertation without the support of my friends also, Ousmane Issa, Alpha O. Hiadara, Boubacar A. Kassoum, and Djiberou M. A. Jalil, who provided happy distractions to rest my mind outside of my research.

Finally, to all invisible hands that have contributed in some way to this dissertation, thank you!

Ali MAMADOU MAMADOU

March 21, 2022

SUMMARY

Context. Heterogeneous networks refer to the coexistence and coverage of multiple communication networks in a common area. It is a fundamental feature in the paradigm of recent generation networks to support a wide range of novel applications that compel low latency and high data rates, for both indoor and outdoor use scenarios. During the first development of wireless technologies, wireless connectivity was only possible with one operator/technology. However, with the densification of heterogeneous networks deployment of recent generation networks such as in the 5G paradigm, computing and communication devices such as smartphones or connected vehicles are using multiple wireless technology/interfaces such as Wi-Fi, 4G LTE/5G, Bluetooth, each usually suited for a particular usage.

Goal. This thesis's framework provides efficient interface coexistence techniques for multi-wireless access network interface terminals through an interface and interfaces information sharing. The framework has two main components: a Radio Access Technology (RAT) selection mechanism and an IEEE 802.11 (Wi-Fi) and IEEE 802.15.4 (e.g. ZigBee) coexistence optimization technique.

Method. The RAT selection proposal is formulated as a Multi-Criteria Decision-Making (MCDM) problem with a decision data analysis mechanism that allows accurate network performance estimation in the decision-making process. The IEEE 802.11 (Wi-Fi) and IEEE 802.15.4 (e.g. ZigBee) coexistence optimization technique benefit of virtual Clear Channel Assessment (CCA) from an IEEE 802.11 interface on the same device. Proposals are evaluated using full-stack network simulating which adds a more practical perspective to the results. Indeed, we developed a framework of heterogeneous network simulation by integrating the most popular open-source network simulation modules in the OMNeT++ (C++ framework) ecosystem: INET and SimuLTE. INET is considered for IEEE protocol models such as 802.11 and 802.15.4. SimuLTE is considered for 3GPP protocol models such as LTE-D2D.

Results. Numerical results show the effectiveness of the Radio Access Technology (RAT) selection mechanism as a QoS-based resource optimization method and outperform some baseline mechanisms by up to 66% on delay performance for example. Numerical results show also that the proposed mechanisms of IEEE 802.11 (Wi-Fi) and IEEE 802.15.4 coexistence optimization improve the packet delivery ratio of the standard CSMA/CA by up to 26% under traffic load in a Wi-Fi that does not exceed 40% of offered load.

Conclusions. We argue in this thesis that the concept of interface and interfaces information sharing for multi-wireless access network interface terminals can positively impact wireless resource efficiency.

RESUMÉ

Contexte. Les réseaux hétérogènes désignent la coexistence et la couverture de plusieurs réseaux de communication dans une zone commune. Il s'agit d'une caractéristique fondamentale du paradigme des réseaux de dernière génération, qui permet de prendre en charge un large éventail d'applications nouvelles nécessitant une faible latence et des débits de données élevés, pour des scénarios d'utilisation en intérieur comme en extérieur. Au cours du premier développement des technologies sans fil, la connectivité sans fil n'était possible qu'avec un seul opérateur/technologie. Cependant, avec la densification des réseaux hétérogènes et le déploiement des réseaux de dernière génération, comme dans le paradigme 5G, les appareils informatiques et de communication, tels que les smartphones ou des véhicules connectés, utilisent plusieurs technologies sans fil telles que Wi-Fi, 4G LTE/5G, Bluetooth, chacune étant généralement adaptée à un usage particulier.

Objectif. L'objectif de cette thèse est de fournir des techniques efficaces de coexistence de technologies pour des terminaux ayant plusieurs interfaces de réseau d'accès sans fil par le biais d'un partage des ressources et d'informations sur l'interface. La valeur ajoutée de la thèse a deux composantes principales : un mécanisme de choix de technologies d'accès radio et des techniques d'optimisation de la coexistence des technologies IEEE 802.11 (Wi-Fi) et IEEE 802.15.4 (e.g. ZigBee).

Méthode. La proposition de mécanisme de choix de technologie d'accès radio est formulée comme un problème de prise de décision à critères multiples (MCDM) avec un mécanisme d'analyse des données de décision qui permet une estimation fiable des performances du réseau dans le processus de prise de décision. La technique d'optimisation de la coexistence Wi-Fi et ZigBee bénéficie d'une évaluation virtuelle du canal (Clear Channel Assessment - CCA) fournie par l'interface Wi-Fi sur le même appareil. Les propositions sont évaluées à l'aide de simulations de réseaux à pile de protocoles complète, ce qui ajoute par ailleurs une dimension pratique aux résultats. En effet, nous avons développé un cadre de simulation de réseaux hétérogènes en intégrant les modules de simulation de réseaux open-source les plus populaires de l'écosystème OMNeT++ (Framework en C++): INET et SimuLTE. INET est considéré pour les modèles de protocole IEEE tels que 802.11 et 802.15.4. SimuLTE est considéré pour les modèles de protocoles 3GPP tel que LTE-D2D.

Résultats. Des résultats numériques montrent l'efficacité du mécanisme de choix de technologie d'accès radio comme méthode d'optimisation des ressources basée sur la Qualité de Service (QoS) et surpassent des mécanismes de base jusqu'à 66% en terme de délai d'accès au canal pour les applications sensibles au délai. Des résultats numériques montrent également que les mécanismes proposés d'optimisation de la coexistence de Wi-Fi et ZigBee réduisent, par rapport au mécanisme CSMA/CA de base, le taux de pertes des paquets jusqu'à 26 % sous une charge de trafic dans un réseau Wi-Fi ne dépassant pas 40 % de la charge maximal du canal.

Conclusions. Nous avançons dans cette thèse que le partage des interfaces et d'informations d'interface pour les terminaux de réseaux d'accès sans fil multiples peut avoir un impact positif sur l'efficacité des ressources sans fil.

CONTENTS

Dedication	ii
Acknowledgments	iii
Summary	iv
Resumé	v
List of Figures	viii
List of Tables	x
List of Abbreviations	xi
Chapter 1: Introduction	1
1.1 Context and main focus	1
1.1.1 Heterogeneous networks	1
1.1.2 Opportunities and challenges	2
1.2 Thesis contributions	4
1.2.1 Access technology selection mechanism	4
1.2.2 IEEE 802.11 and IEEE 802.15.4 coexistence optimization	4
1.3 Thesis structure	4
Chapter 2: Background	6
2.1 Wireless resource sharing in heterogeneous networks	6
2.1.1 Resource sharing in wireless standard technologies	6
2.1.2 MAC protocols in cognitive radio environment	18
2.1.3 MAC protocols orchestration	20
2.1.4 IEEE 802.15.4 and IEEE 802.11 coexistence optimisation	22
2.1.5 Opportunities and open issues	24
2.2 Access Technology Selection mechanisms in heterogeneous networks	28
2.2.1 Multiple Criteria Decision Making based methods	30
2.2.2 Artificial Intelligence-based methods	33
2.2.3 Challenges and key issues	37
2.3 Conclusion	38
Chapter 3: Contributions	40
3.1 Distributed User-centric Radio Access Technology Selection framework: DU-RATS	40
3.1.1 Design rationales	40
3.1.2 RAT selection problem model	42
3.1.3 Decision criteria	43
3.1.4 Decision process	44
3.1.5 Decision data processing	45
3.1.6 RAT ranking	47
3.2 IEEE 802.15.4 MAC aware of IEEE 802.11	52
3.2.1 Backoff mechanism 1 for delay tolerant applications	52
3.2.2 Backoff mechanism 2 for non delay tolerant applications	54
Chapter 4: Results and Discussion	57
4.1 Distributed User-centric Radio Access Technology Selection framework: DU-RATS	57

4.1.1	Simulation model	57
4.1.2	Subjective weights calculation	58
4.1.3	DURATS with a single application	62
4.1.4	DURATS with multiple applications	69
4.2	IEEE 802.15.4 MAC aware of IEEE 802.11	78
4.2.1	Simulation model and parameters	78
4.2.2	Numerical results	80
Chapter 5:	Conclusions and Perspectives	88
5.1	Conclusion	88
5.1.1	Access Technology Selection	88
5.1.2	IEEE 802.15.4 MAC aware of IEEE 802.11	88
5.1.3	Performance evaluation	89
5.2	Perspectives	89
5.2.1	DURATS parameters study	89
5.2.2	Impact of higher layer protocols on DURATS	90
5.2.3	Enhanced DURATS decision data estimation	90
5.2.4	Channel information sharing between more technologies	90
List of Publications		91
References		R1
Appendix A		A1

LIST OF FIGURES

1.1	Heterogeneous networks scenario in a typical urban environment.	2
1.2	5G use case scenarios	3
2.1	LTE MAC structure overview of EU from 3GPP's in Technical Specification (TS) 36.321 (Release 8).	8
2.2	Overview of the random access process in LTE-A MAC.	9
2.3	Procedures for data transmissions in LTE-D2D unicast network-assisted communication scenario [72].	10
2.4	Basic CSMA/CA mechanism in DCF.	13
2.5	Example of the channel access method of DCF with RTS/CTS [64]	14
2.6	Flowchart of unslotted and slotted CSMA/CA algorithm in IEEE 802.15.4.	17
2.7	Network deployment scenario implementing a resource sharing approach	25
3.1	Architecture of DURATS enabled multi-interface network node.	42
3.2	Data Life-Time ($\delta_1, \delta_2, \delta_3$) function.	46
3.3	Illustration of three decision criteria normalization	49
3.4	Flow chart of the extended CSMA/CA mechanism 1 in IEEE 802.15.4 to improve coexistence with IEEE 802.11.	53
3.5	Flow chart of the extended CSMA/CA mechanism 2 in IEEE 802.15.4 to improve coexistence with IEEE 802.11.	55
4.1	Simulation scenario composed of two node groups: decision makers and dummy traffic generators.	63
4.2	Delay based decision results for Conversational application.	64
4.3	Throughput based decision results for Streaming application.	66
4.4	<i>DDR</i> based decision results for Interactive application.	68
4.5	Simulation scenario composed of four node groups each with different interface selection mechanism.	70
4.6	DURATS and DURATS-simple delay-based decision results for Conversational application vs. random and fixed decision results.	73
4.7	DURATS and DURATS-simple throughput based decision results for Streaming application vs. random and fixed decision results.	75
4.8	DURATS and DURATS-simple <i>DDR</i> based decision results for Interactive application vs. random and fixed decision results.	77
4.9	WLAN and WPAN co-located with ten traffic source nodes and one traffic destination node in each network.	79
4.10	The average packet loss ratio in the WPAN as a function of offered load in WLAN.	81
4.11	The average application throughput in WLAN with 40% of offered load relative to data rates used and different CSMA/CA mechanisms in WPAN.	82

4.12	The average absolute application throughput in WLAN with 40% of offered load using different data rates and CSMA/CA mechanisms in WPAN.	82
4.13	The average channel occupancy ratio by WLAN with 40% of offered load using different data rates and CSMA/CA mechanisms in WPAN.	83
4.14	The average channel occupancy ratio in WLAN due to physical layer overhead (preamble and header) with 40% of offered load using different data rates and CSMA/CA mechanisms in WPAN.	84
4.15	The average number of failed transmission attempts in WPAN as a function of offered load percentage in WLAN. The results are calculated based on the values of all transmitter nodes.	85
4.16	Average access delay of frames in WPAN as a function of offered load percentage in WLAN. (Mechanism 1 vs base mechanism)	86
4.17	Average access delay of frames in WPAN as a function of offered load percentage in WLAN. (Mechanism 2 vs base mechanism)	86

LIST OF TABLES

2.1	Summary of related work toward channel efficiency in IEEE 802.15.4 coexisting with IEEE 802.11.	24
2.2	Summary table of deterministic RAT selection methods	31
2.3	Summary table of Artificial Intelligence-based RAT selection methods	35
4.1	End-user performance expectations of some multimedia applications [11]. . .	58
4.2	Normalized end-user performance expectations of some multimedia applications.	59
4.3	Pairwise comparison matrices from end-user performance expectations	60
4.4	Weight vector of use case applications derived from end-user performance expectations	62
5.1	Simulation parameters for evaluation of IEEE 802.15.4 and IEEE 802.11 coexistence techniques.	A1
5.2	Standard deviation values of the averages related to the WLAN metrics with 40 % of the offered load rounded to two decimal places.	A1
5.3	Standard deviation values of the averages related to the WPAN metrics rounded to two decimal places.	A2

LIST OF ABBREVIATIONS

Symbol	Description
<i>SuccessTransData</i>	Total number of data packets successfully sent
<i>TransData</i>	Total number of data packets attempted to be transmitted
<i>DLT</i>	Statistic data time interval
δ	Statistic data time interval boundary
δ_{min}	Minimum statistic data time interval boundary
δ_{max}	Maximum Statistic data time interval boundary
<i>QstayDuration</i>	Time a packet remained in MAC queue until reaching top
<i>AccessDelay</i>	Time to transmit a packet reaching top of MAC queue
γ	Access interface usage period
τ	Statistic data samples size
α	Smoothing constant of moving average
<i>N</i>	Number of use case applications
<i>M</i>	Number of decision criteria
<i>I</i>	Number of alternative network interfaces

ACRONYMS

- 3Gpp** 3rd Generation Partnership Project. 7
- 4G** fourth generation of mobile networks. 7
- ABC** Always Best Connect. 3
- ACK** acknowledgement. 86, A1
- AHP** Hierarchical Analysis Process. 29, 30
- AIFS** Arbitration InterFrame Space. 14
- ANN** Artificial Neural Networks. 29
- AP** Access Point. 12, 15, 79, 83
- ATP** Adaptive Transmit Power. 16
- B-CSMA** Basic CSMA/CA mechanism in IEEE 802.15.4. 80
- BCCH** Broadcast Control Channel. 8
- BCH** Broadcast Channel. 8
- BE** Backoff Exponent. 17, 52, 54
- BSS** Basic Service Set. 15, 16
- C-ITS** Cooperative Intelligent Transportation System. 11
- CCA** Clear Channel Assessment. iv, 4, 12, 16, 17, 78–80, 85, 87
- CCCH** Common Control Channel. 8
- CF** Coordination Function. 11
- CFP** Contention Free Period (CFP). 12
- CP** Contention Period. 12
- CR** Cognitive Ratio. 6
- CSMA** Carrier Sense Multiple Access. 11
- CSMA/CA** Carrier Sense Multiple Access with Collision Avoidance. 11, 14, 16, 17
- CSMA/CA** Carrier Sense Multiple Access with Collision Avoidance. iv, viii, ix, 52–55, 80–84, 86, 88–90, A1
- CST** Carrier Sensing Threshold. 16
- CTS** Clear-To-Send. 13, 15, 16, 80
- CV** Coefficient of Variation. 45, 90
- CW** Contention Window. 12, 14
- DCCH** Dedicated Control Channel. 8
- DCF** Distributed Coordination Function. 11–16, 52, 72
- DDR** Data Delivery Ratio. 43, 50
- DIFS** DCF interFrame Spacing. 12, 13
- DL-SCH** Downlink Shared Channel. 8
- DLT** Data Life Time. 44

DTCH Dedicated Traffic Channel. 8

DURATS Distributed User-centric Radio Access Technology Selection framework. 4, 40, 57, 88

E-CSMA-1 Extension 1 to CSMA/CA mechanism in IEEE 802.15.4. 80

E-CSMA-2 Extension 2 to CSMA/CA mechanism in IEEE 802.15.4. 80

EDCA Enhanced Distributed Channel Access. 14

FAHP Fuzzy Analytic Hierarchy Process. 29

HARQ Hybrid Automatic Repeat reQuest. 8

HCCA HCF Controlled Channel Access. 14

HCF Hybrid Coordination Function. 12, 14

HetNet Heterogeneous networks. 1

IEEE Institute of Electrical and Electronics Engineers. viii, x, 4, 11, 13, 17, 22–24, 53, 55, 57, 78–80, 88–90

IETF Internet Engineering Task Force. 57

IMT International Mobile Telecommunications. 3, 7

ISM Industrial, Scientific and Medical. 22, 79

ITU International Telecommunication Union. 2, 3

ITU-R International Telecommunication Union Radiocommunication Sector. 7

LAA License Assisted Access. 7

LTE LTE Vehicle-to-everything. 7

LTE Long-Term Evolution. 7, 9

LTE-D2D LTE Device-to-Device. 7, 9, 10

MAC Medium Access Control. 12, 14, 15, 22

MCDM Multi-Criteria Decision-Making. iv, 29, 30, 37, 58, 88

MCS Modulation and Coding Scheme. 9

MIB Master Information Block. 8

MIMO Multiple-Input and Multiple-Output. 23

NAV Network Allocation Vector. 13, 52, 54, 79, 90

NB Number of Backoff of the current frame. 17, 52, 54

OFDM Orthogonal Frequency Division Multiplexing. 79

PCCH Paging Control Channel. 8

PCF Point Coordination Function. 11, 12, 14
PHY Physical Layer. 22
PIFS PCF interFrame Spacing. 12

QoE Quality-of-Experience. 90
QoS Quality-of-Service. 12, 14, 27

RACH Random Access Channel. 8, 10, 72
RAT Radio Access Technology. iv, 3, 29, 30, 40, 49, 57
RNTI Radio Network Temporary Identifier. 9
RRC Radio Resource Control. 9
RTS Request-To-Send. 13, 15, 16, 80

SIFS Short interFrame Spacing. 12
SNIR Signal-to-Noise plus Interference Ratio. 79
STA Station. 12

TC Traffic Class. 12, 14
TOPSIS Technique for Order Preference by Similarity to an Ideal Solution. 29, 30, 50
TS Technical Specification. viii, 8
TWT Target Wake Time. 16

UDP User Datagram Protocol. 80, A1
UE User Equipment. 9, 10
UP-SCH Uplink Shared Channel. 8

VANET Vehicular Ad-hoc Network. 15

Wi-Fi Wireless Fidelity. 1, 4, 15, 22–24, 52, 78, 79
WLAN Wireless Local Area Network. viii, ix, 4, 11, 13, 52, 78–87, 89, A1
WLS Weighted Least Squares. 48, 60
WPAN Wireless Personal Area Network. viii, ix, 78–87, A1

CHAPTER 1

INTRODUCTION

This chapter aims to present the work and motivations behind the work. The stakes are to highlight the research questions, provide a high-level explanation of the solution and the contributions. Thus, in section 1.1, we start by providing the context and primary focus of this thesis: coexistence and coverage of multiple communication networks in a common area as a fundamental feature in the paradigm of recent generation networks. We also discuss the opportunities and challenges of networks coexistence, focusing on the thesis contribution. Then, in Section 1.1, we provide a high-level explanation of the contributions of this thesis. We end the chapter with the presentation of the structure of this manuscript in Section 1.3.

1.1 Context and main focus

This section provides the context of this thesis and the focus of the thesis-related issues and contributions to help the reader well position the work.

1.1.1 Heterogeneous networks: definition and characteristics

The development of wireless technologies has revolutionized the world of communications where multiple technologies are evolving simultaneously towards providing users with high-quality broadband access and seamless mobility services. On the one hand, wireless wide area networks (WWANs) evolve from GSM to 5G and beyond, providing broad coverage and good mobility capabilities. On the other hand, a series of wireless local area networks (WLANs) standards, including IEEE 802.11abglnlaclax have been established for local-area high-speed low-cost wireless access. To complement them, wireless personal area networks (WPANs), e.g., Bluetooth and Zigbee, and wireless metropolitan area networks (WMANs), e.g., WiMAX, are developed for short-range and metropolitan coverages, respectively. All the above networks have been deployed with coverage overlapping, forming a hybrid network for wireless access, usually called heterogeneous wireless networks (HetNet) [73]. Each of the technologies forming a network is generally better suited for a given application, e.g., Wi-Fi and LTE for mobile broadband internet access, ZigBee for monitoring environmental sensors, and Bluetooth for entertainment. Thus, the coexistence and coverage of multiple communication networks in a common area of Heterogeneous networks (HetNet) is a fundamental feature in the paradigm of recent generation networks to support a wide range of novel applications requiring low latency and high data rates for indoor and outdoor use scenarios.

Nowadays, connected devices such as smartphones or vehicles are critical computing and communication platforms. During the first development of wireless technologies, wireless connectivity was only possible with one operator/technology. However, nowadays, connected devices are capable of using multiple wireless capabilities. These end-users are often equipped with multiple radio interfaces (Bluetooth, Zigbee, and Wi-Fi), which complements their i.e. 4G LTE/5G cellular communication capabilities. According to a recent market research report,

more than 75% of mobile phones have a Bluetooth interface, while 96% are Wi-Fi enabled [51]. In addition to these technologies, additional WPANs and WLANs interfaces (i.e., Zigbee and LTE/Wi-Fi direct) are getting integrated into these connected devices. They provide domestic equipment control and boost mobile broadband demand through Device-to-Device communication.

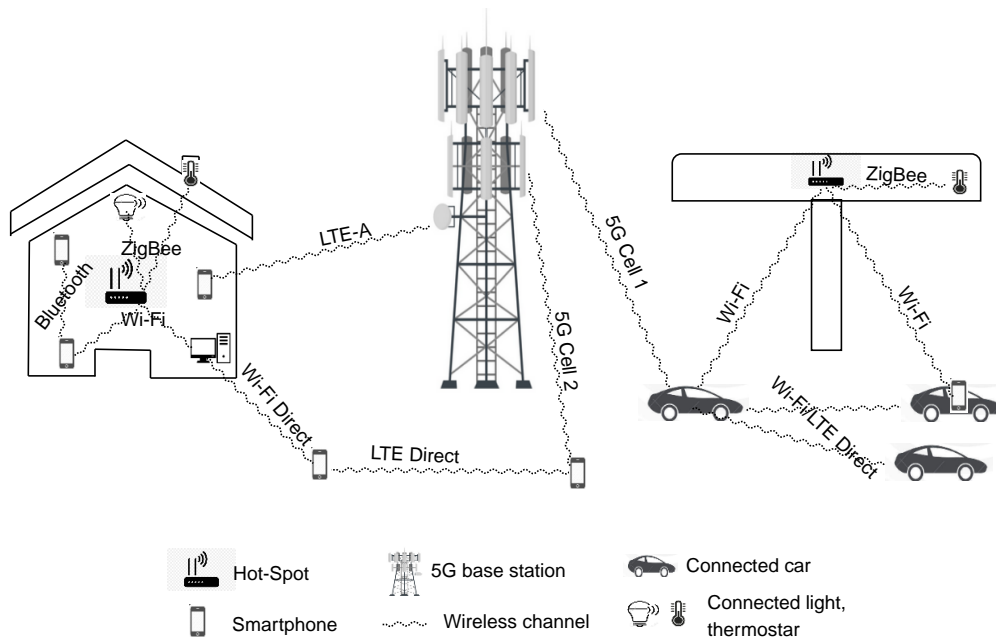

FIGURE 1.1 Heterogeneous networks scenario in a typical urban environment.

Figure 1.1 illustrates a heterogeneous networks scenario in a typical urban environment. In the scenario, multi-technology home and gas station Hot-spots and a base station facilitate communications of multiple connected devices (e.g. smartphones, vehicles and sensors).

1.1.2 Opportunities and challenges in heterogeneous networks design

With multiple coexisting technologies, each usually suited for a particular usage, the deployment of heterogeneous networks architecture allows networks to support a wide range of applications. The latter is of particular interest as a feature for the paradigm of recent generation networks such as 5G, aiming to support a wide range of novel applications requiring low latency and high data rates for both indoor and outdoor use scenarios. Some great examples of these applications are augmented/virtual reality, industry control/automation, remote surgery, intelligent/collaborative transportation systems to enable, for example, remote driving, and collective awareness for road traffic efficiency and security. Figure 1.2 illustrates these use cases with respect to the three typical requirements of 5G infrastructures according to International Telecommunication Union (ITU). i) High data rates across a wide coverage area (known as

eMBB for enhanced Mobile BroadBand), ii) strict requirements of low communication latency (known as URLLC for Ultra-Reliable Low Latency Communications), and iii) support for dense IoT deployments known as massive Machine Type Communication (mMTC).

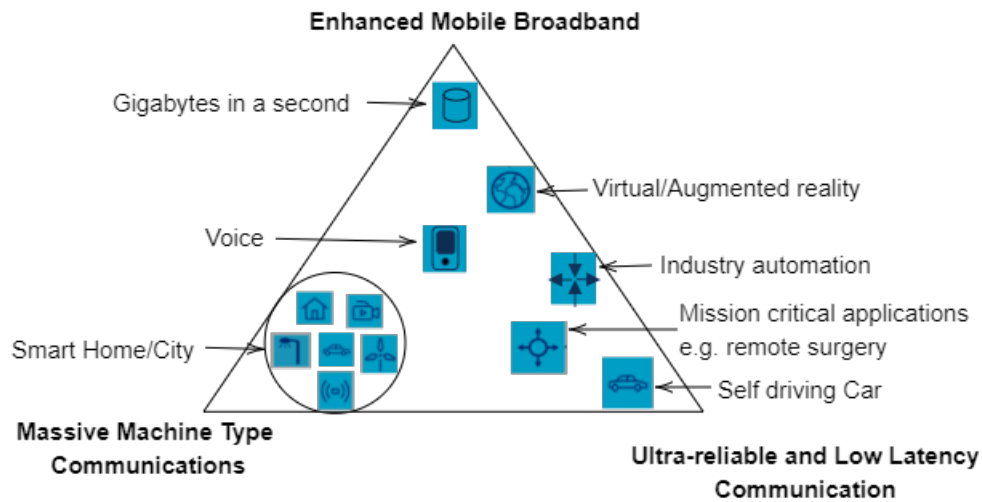

FIGURE 1.2 5G use case scenarios from International Telecommunication Union (ITU) as future International Mobile Telecommunications (IMT) [70]

One of the design challenges of these heterogeneous networks relates to radio resource management and coexistence problem. Indeed, many of the technologies use the same or partially overlapping frequency bands for communication, resulting in a coexistence problem. The coexistence of these networks within the same limited frequency band degrades overall channel efficiency due to co-channel interference and the difficulty of implementing inter-network coordination. Thus, fair spectrum sharing and quality of service guarantee in unlicensed bands are among the challenging research topics in wireless networks.

The deployment of heterogeneous networks also allows end-users to have numerous connection possibilities and, consequently, can be constantly connected and better connected. This is well known as Always Best Connect (ABC) and it brings many advantages to users. With ABC functionality, terminals select appropriate access networks to fit various QoS requirements of applications. They avoid selecting a network with a high traffic load to avoid congestion. They minimize signaling costs by using autonomous network selection techniques.

Although ABC requires astucious decision mechanisms to associate technology when a new user session or handover session arrives, this is best known as the Radio Access Technology (RAT) selection. RAT selection issues in heterogeneous networks are among the main design

challenges for multi wireless access network interface terminals, which is our focus in this thesis. Indeed, this thesis focuses on providing efficient interface coexistence techniques for multi-wireless access network interface terminals through an interface and interface information sharing.

1.2 Thesis contributions

In this thesis, we propose a framework of coexistence techniques for heterogeneous wireless networks for multi-interface terminals. The framework has two main components. (i) We propose a decentralized mechanism for choosing access technologies within a multi-interface node namely DURATS for Distributed User-centric Radio Access Technology Selection framework. And (ii) a coexistence optimization technique for IEEE 802.11 and IEEE 802.15.4 is proposed.

1.2.1 Access technology selection mechanism

We propose a radio access technology selection framework for applications with QoS requirements. We call this framework DURATS for Distributed User-centric Radio Access Technology Selection framework. We consider network nodes having a set of use case application profiles and access technologies. Each application profile generates data where a functional module called Decider chooses the most suited transmission interface based on local statistics. This is motivated by the need to provide a decision framework based on decision metrics that network nodes can collect locally without needing a specific coordination mechanism with other nodes and using their standard interfaces.

1.2.2 IEEE 802.11 and IEEE 802.15.4 coexistence optimization

We tackle the coexistence issue of IEEE 802.11 and IEEE 802.15.4 from the access layer point of view. Indeed, we propose an extension to the IEEE 802.15.4 access mechanism that takes into account information collected at a multi-interface node (such as a mobile phone) to enhance channel efficiency and reduce the energy footprint of the access method. We propose two backoff algorithms in IEEE 802.15.4 using virtual Clear Channel Assessment (CCA) from a Wireless Local Area Network (WLAN) interface. The rationale behind the proposal is to allow IEEE 802.15.4 devices to be aware of the future activities announced in the control traffic of Wi-Fi. This awareness enables them to avoid attempting to access the channel during the activity period of Wi-Fi devices. By doing so, IEEE 802.15.4 devices will be able to avoid losing packets due to interference with the Wi-Fi network.

1.3 Thesis structure

This Chapter 1 highlighted the research questions in this thesis and provided a high-level explanation of the solution and its contributions. In the remainder of the document, we start in

Chapter 2 with a literature review and background related to research questions and contributions in this thesis. Thus, we provide a review of scholarly articles related to issues of heterogeneous networks, including Access technology selection mechanism and IEEE 802.11 and IEEE 802.15.4 coexistence optimization technique. We also present resource-sharing techniques in wireless technologies considered in the framework of this thesis with their brief background and evolution.

Next, in Chapter 3, to allow readers to evaluate the reliability of the research, we explain and discuss the methods of the actual thesis contribution, which are a RAT selection mechanism and are IEEE 802.11 and IEEE 802.15.4 coexistence optimization technique.

Then, in chapter 4, we report and discuss our simulation-based performance evaluation results. We also discuss our research's main findings, including enhanced throughput, reduced energy consumption, and QoS-based resource optimization.

Finally, in Chapter 5, we summarize this thesis contribution and recommend future work on the topic, such as machine learning techniques and extension of information sharing concept between more technologies for better resource efficiency.

CHAPTER 2

BACKGROUND ON EXISTING TECHNIQUES FOR HETEROGENEOUS COEXISTENCE AND OPEN ISSUES

This chapter provides a background on existing techniques for heterogeneous networks coexistence in the literature and discusses opportunities and open issues. We start by providing an overview of the existing techniques for wireless resource sharing in heterogeneous networks, focusing on access layer techniques in section 2.1. We call resource sharing a scenario of deploying and managing heterogeneous applications and networking technologies for global resource use efficiency. Resources can be Spectrum, network nodes or access interfaces (which is our main focus). Then, in section 2.2, we provide an in-depth study on Access Technology Selection mechanisms as an essential component in designing heterogeneous networks coexistence and the main contribution of this thesis.

2.1 Wireless resource sharing in heterogeneous networks

We start this section with a description of resource sharing techniques in wireless technologies considered in the framework of this thesis with their brief background and evolution. Then, we describe how MAC protocols can include Cognitive Ratio (CR) features that allow them to use the available spectrum better (in subsection 2.1.2). We give an overview of protocols that switch between different MAC protocols to better adapt to the surrounding environment (in subsection 2.1.3). Then, we review existence techniques of coexistence in the case of IEEE 802.15.4 and IEEE 802.11 (in subsection 2.1.4). We end the section with a suggestion of several open issues for allowing heterogeneous networking technologies to coexist efficiently in general according to a typical coexistence example for better resource sharing (in subsection 2.1.5).

2.1.1 Resource sharing in wireless standard technologies

Wireless network technologies are deployed under two modes of spectrum regulation: *Licensed spectrum*, such as for 4G LTE, and *Unlicensed spectrum*, such as for Wi-Fi. This fundamental difference is reflected within the access procedures of these technologies. In fact, access procedure of licensed technologies having interference protection guaranteed by law is typically based on scheduling, while one of the unlicensed technologies having no interference protection guaranteed by law is based on contention. In what follows, we describe licensed and unlicensed wireless technologies that we have considered in the framework of this thesis by focusing on their access layer procedures.

Licensed wireless technologies

In this section, we start with some background on Long-Term Evolution (LTE). Then present its extension namely LTE-Direct or LTE-D2D considered in the framework of this thesis. We mainly focus on the access layer techniques such as protocol layering and resource allocation.

4G LTE

Long-Term Evolution (LTE) is a standard for wireless broadband communication for mobile-enabled data terminals developed by the 3rd Generation Partnership Project (3Gpp). The International Telecommunication Union Radiocommunication Sector (ITU-R) organization initially set forth the requirements of this standard in the International Mobile Telecommunications (IMT) Advanced specification as the fourth generation of mobile networks (4G) of mobile networks.

LTE is marked "4G LTE" or "LTE Advanced" and is specified in Release 8-14. Release 8 specifies different radio interfaces together with core network improvement and lays the foundations of the technology. From Release 8, each release extends the original features with new ones, such as LTE Device-to-Device (LTE-D2D) communication in release 9, License Assisted Access (LAA) in release 13 and LTE Vehicle-to-everything (LTE) communication in release 14.

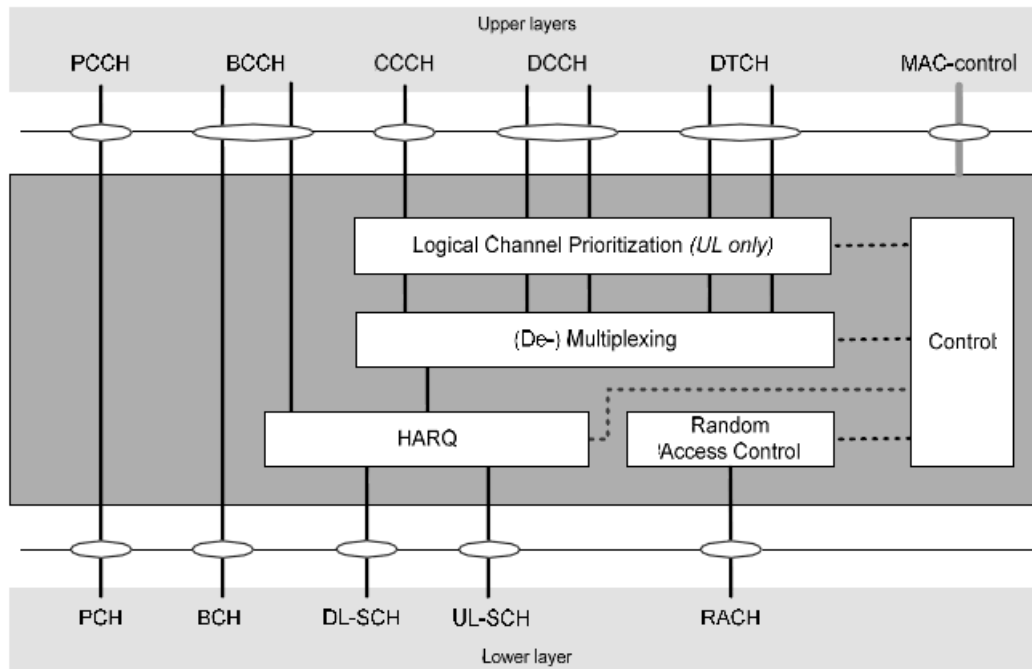

Figure 4.2.1.1: MAC structure overview, UE side

FIGURE 2.1 LTE MAC structure overview of EU from 3GPP's in Technical Specification (TS) 36.321 (Release 8).

Diagram of Figure 2.1 from TS 36.321 (Release 8) shows the mapping for various logical upper layer channels and physical channels by the LTE MAC layer. The logical upper layer channels are Paging Control Channel (PCCH), Broadcast Control Channel (BCCH), Common Control Channel (CCCH) for control plane, and are Dedicated Control Channel (DCCH), Dedicated Traffic Channel (DTCH) for user plane. The physical channels are Broadcast Channel (BCH), Downlink Shared Channel (DL-SCH), Uplink Shared Channel (UP-SCH) and Random Access Channel (RACH).

All the logical channels (PCCH, BCCH, CCCH, DCCH, DTCH) go through the MAC layer. The PCCH used to transfer paging information and system information change notifications such as location cell of the UE do not get manipulated by MAC in any particular way. Thus, it does not use the Hybrid Automatic Repeat reQuest (HARQ) procedure, and therefore 'no retransmission' mechanism is being used to provide reliability at the MAC layer on this channel. Some BCCH messages such as Master Information Block (MIB) information broadcasted by the LTE eNodeB of any user's presence do not go through HARQ since they do not expect any ACK/NACK response from the receiver but performs 'retransmission' based on a predefined rule. CCCH, DCCH, DTCH all go

through the same Prioritization, Multiplexing/Demultiplexing, and HARQ procedures. Random Access process messages originating within the MAC layer (MAC-Control) are not directly mapped into a physical channel but go through the RACH depending on EU's Radio Resource Control (RRC) connection status.

The random Access process message on RACH is the first message from UE to eNB when powered on. Its primary purpose is first to achieve uplink (UL) synchronization between UE and eNodeB and then obtain the resource for establishing an RRC connection.

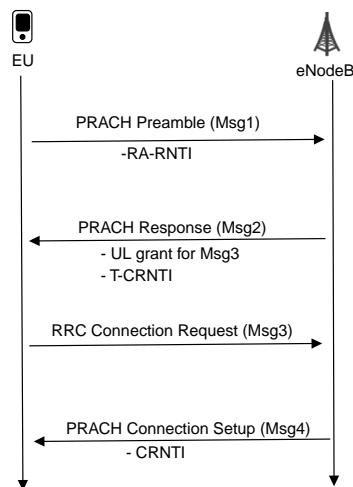

FIGURE 2.2 Overview of the random access process in LTE-A MAC.

In particular, regarding Fig 2.2, the RRC connection is established as follows. The EU starts with sending a Physical RACH Preamble carrying Random Access Radio Network Temporary Identifier (RNTI) (RA-RNTI) signature (Msg1). The eNodeB uses the latter to detect contention when multiple UEs attempts to use identical signatures. Then, if contention is not detected, the eNodeB sends RACH response with RA-RNTI carrying a new RNTI (namely T-CRNTI for Temporary Cell RNTI) with uplink resource assignment and Modulation and Coding Scheme (MCS) configuration to receive the subsequent RRC connection request (Msg3). EU sends the RRC connection request using the CRNTI from its RACH response. The EU receives the RRC connection setup carrying the Cell RNTI (CRNTI). From this point, the eNB uses the CRNTI to allocate a UE with uplink resource grants for user plane traffic.

LTE-D2D unicast

LTE Device-to-Device (LTE-D2D) communication allows two LTE User Equipment

(UE) to communicate directly without necessarily passing through eNodeB. This mode of communication is also called Side Link (SL). There are two types of LTE-D2D communication: Network-unassisted and Network-assisted. Network-unassisted D2D is foreseen for coverage extension or contingency scenarios where two UEs can autonomously occupy frequency resources for their communication possibly using a cognitive approach. With network-assisted D2D, which is considered in the framework of this thesis, the eNB instructs the receiving UE to listen on the same resource blocks (RBs) granted for transmission to the transmitting UE. Hence the eNB exchanges control information with both UE, but it is not involved in data exchange. LTE-D2D communication can be both unicast and multicast. Multicast D2D can be used for proximity-based services (e.g., advertisement, alerts), whereas unicast D2D can be used for peer-to-peer services, e.g., file transfer, browsing.

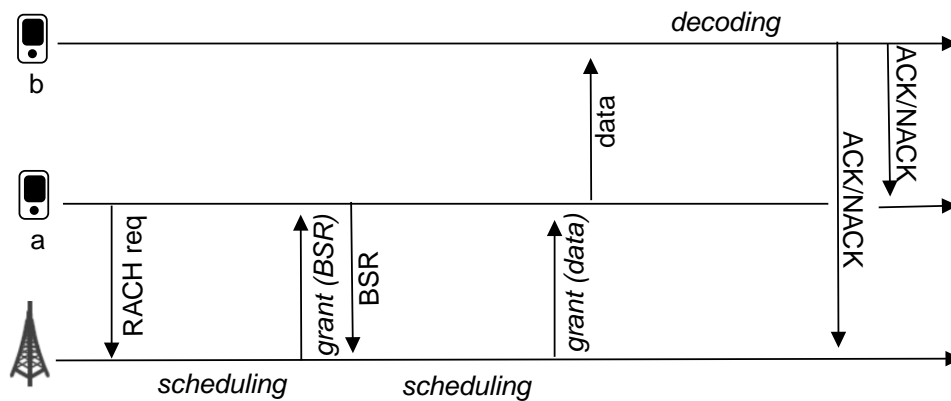

FIGURE 2.3 Procedures for data transmissions in LTE-D2D unicast network-assisted communication scenario [72].

In network-assisted, D2D resource allocation is done by the eNB at the MAC layer as for normal UL. The eNodeB issues transmission grants to the UEs, specifying which RBs (time and frequency) they can use, using what transmission format. Since the buffers reside at the UEs, UEs must send Buffer Status Reports (BSRs) to report their backlog. This latter is transmitted to the eNodeB, possibly trailing a data transmission, when the UE is scheduled and has enough space to do so (a BSR can take up to 24 bits). Although, A UE can signal a new backlog through an out-of-band Random Access Channel (RACH) procedure. RACH requests are responded in-band by the eNB, which schedules the UE in a future Transmission Time Intervals (TTIs) of 1ms. Unanswered RAC requests are re-iterated after a backoff period. Figure 2.3 illustrates Procedures for

data transmissions, UE requests an SL grant in much the same way as it would a UL one, and UE must be able to ack/nack the eNodeB.

There are several open points regarding D2D unicast transmission. One is how to identify the endpoints. This can be done using device class, subscription profile, geographical position, or flow type. Another problem is how to decide when to switch from the Network-unassisted mode to Network-assisted mode or back. Alternatively, decide when to switch from normal UL to SL or back. Furthermore, how all this can be done seamlessly.

Unlicensed wireless technologies

This section presents the access mechanism of two unlicensed access technologies considered in this thesis: IEEE 802.11 and IEEE 802.15.4. We mainly focus on the access layer, such as the medium access control techniques.

IEEE 802.11

The IEEE 802.11 standard series is the most popular standard for Wireless Local Area Network (WLAN) technologies in the environment of connected cities such as Cooperative Intelligent Transportation System (C-ITS) infrastructures, airports or stadiums. Except for IEEE 802.11b, most of these standards are based on Carrier Sense Multiple Access (CSMA), a variant of contention-based access procedures. In the versions of the IEEE 802.11 series of standards that use CSMA access methods. It is the case of the original 802.11a (1999), 802.11g (2003) and those defined later, including 802.11e (2005), 802.11p (2010), 802.11ac (2013), 802.11ax (2020). Their overall principle of synchronization mechanisms and channel access is based on three types of coordination techniques, called Coordination Function (CF). Each of these CFs is used depending on the topology of the network deployment, with or without an infrastructure. These three coordination techniques are the following:

Distributed Coordination Function (DCF): this is a Carrier Sense Multiple Access with Collision Avoidance (CSMA/CA) based mechanism that allows nodes to access the channel competitively without the need for central coordination device. DCF is the fundamental mechanism on which others in the IEEE 802.11 standard series are based.

Point Coordination Function (PCF): this mechanism allows channel usage without

competition between nodes, thanks to stringent scheduling by a central node, usually the Access Point (AP). The principle is that beacons sent by the AP delimit two distinct alternative periods. These periods are Contention Period (CP) and Contention Free Period (CFP) (CFP). During the CP, all nodes compete to access the channel via the standard DCF mechanism, therefore the DCF basis of the CFP. During this CP period, the AP gains control of the medium for the next CFP period to come. The AP gains control through a mandatory delay called PCF interFrame Spacing (PIFS) that precedes any channel occupancy test (by a standard node) because it is shorter than the equivalent delay for standard DCF nodes called DCF interFrame Spacing (DIFS). PIFS is, in turn, larger than the Short interFrame Spacing (SIFS), a delay that gives nodes already engaged in a data exchange transaction a greater chance to access the channel. Once the AP has gained control of the channel, the CFP period can begin. During this period, access to the channel is controlled and arbitrated by the AP. Only nodes subscribed during their associations with this AP have privileged access to the channel by explicit authorization from the AP. Any transmission during this CFP period uses only the SIFS or PIFS delays, thus guaranteeing no interruption of the transmission by a standard DCF node, even one newly associated to the network.

Hybrid Coordination Function (HCF): This mechanism compromises the absolute concurrency of DCF and the rigorous scheduling of PCF. It allows emulating a Quality-of-Service (QoS) mechanism at the Medium Access Control (MAC) level within the fundamental contention-based access framework. The principle of HCF is to use several types of frame queues (one for each service category), each with its channel access priority. Therefore, the inherent difficulty of this mechanism is the definition of this priority in proportion to the constraints of each category of service called Traffic Class (TC). These TCs and their concrete priorities mainly differentiate at the MAC level versions of the standard IEEE 802.11 based on HCF, particularly 802.11e and 802.11p.

Figure 2.4 illustrates the CSMA/CA mechanism employed in DCF. A station wishing to transmit listens to the channel status for a DIFS interval. If the channel is idle, it transmits. Otherwise, a backoff time (measured in slot times) is chosen randomly in the interval $[0; CW[$ by the source STA, where *CW* stands *Contention Window*. The slot time is the sum of the RX-to-TX turnaround time, MAC processing delay, and CCA de-

tection time. The backoff timer is decremented by one as long as the channel is sensed idle for a DIFS equal to $SIFS + 2 * SlotTime$. It stops when the channel is busy and resumes when the channel is idle again for at least a DIFS period. CW is an integer whose range is determined by the PHY layer characteristics: CW_{min} and CW_{max} . CW is doubled after each unsuccessful transmission, up to the maximum value determined by $CW_{max} + 1$. When the backoff timer reaches zero, the source transmits the data packet. The receiver transmitted the ACK immediately after the SIFS period, which is less than DIFS.

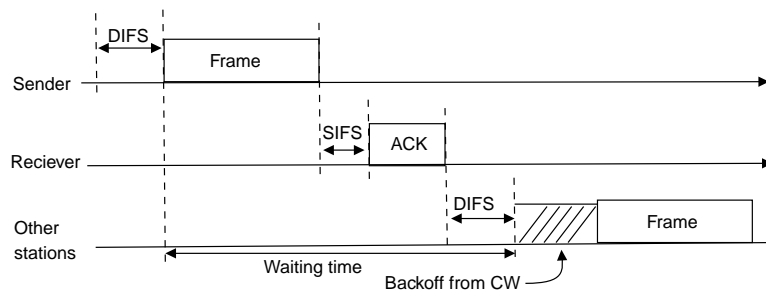

FIGURE 2.4 Basic CSMA/CA mechanism in DCF.

To reduce the hidden node problem in deployed WLANs, DCF allows optional initiation of data exchange transaction with the Request-To-Send (RTS)/Clear-To-Send (CTS) mechanism, in addition to the Network Allocation Vector (NAV) used for virtual sensing. The NAV contains information carried by IEEE 802.11 frames to inform of a period of channel occupancy after the transmission of a current frame. Thus, when allowed, the RTS frame of the transmitter (CTS on the receiver side) carries the duration of transmission and reception of the acknowledgement of the following data frame. This ensures that the medium is reserved and neighboring nodes refrain from accessing it for the time required to transmit the data frame after the RTS/CTS handshake.

Data exchange with the RTS/CTS handshake in IEEE 802.11 DCF channel access method is illustrated in Figure 2.5 with an example implying four nodes. In this example, Node 2 (transmitter) senses the channel before the RTS transmission. If the channel is inactive during the DIFS (Distributed Inter Frame Space) period, Node 2 starts the RTS transmission process. When the channel is busy, Node 2 refrains from transmitting RTS until the channel becomes idle. In the first process, node 2 reduces the backoff time. The initial value of the backoff time is randomly chosen between 0 and the Contention Window (CW). When the channel is idle, Node 2 reduces the backoff time. Otherwise,

Node 2 does not reduce the backoff time. If the backoff counter reaches 0, Node 2 begins RTS transmission. Then, Node 1 (non-receiver) and Node 3 (receiver), which are in the transmission range of Node 2, receive the RTS frame. If Node 3 receives the RTS frame successfully, it transmits the CTS frame, in case Node 3 is ready to receive the data frame from Node 2, after waiting for the Short Inter Frame Space (SIFS) period. Then, Node 2 and Node 4 (non-receiver), which are within the transmission range of Node 3, receive the CTS Frame. Node 2 confirms successful RTS transmission by receiving the CTS frame from Node 4.

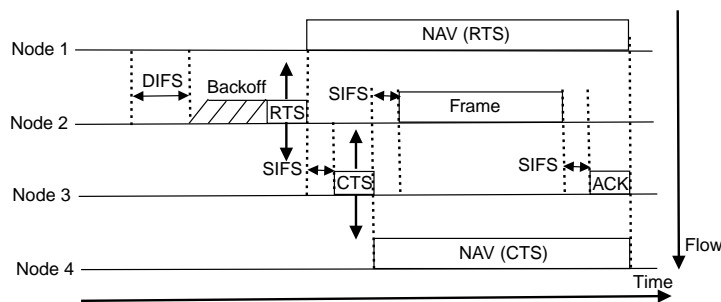

FIGURE 2.5 Example of the channel access method of DCF with RTS/CTS [64]

The operation of the MAC layer of 802.11alg (the initial versions) is globally the same as the DCF and PCF mechanism whose principle we have just stated above. In the rest of this section, we present the main added feature in the MAC layer of different standard versions.

IEEE 802.11e (2005) The need for QoS support at the MAC level, for example, for VoIP applications, motivated the specification and ratification of the 802.11e standard (2005). Indeed, 802.11e mainly takes up the concept of HCF. This standard introduces two new mechanisms: HCF Controlled Channel Access (HCCA) and Enhanced Distributed Channel Access (EDCA). These two new mechanisms introduce Traffic Class (TC), the basic concept for this release. The EDCA mechanism globally defines four levels of TC so that TCs with higher priorities have more chance to use the channel. For this, EDCA uses a backoff and Contention Window (CW) period (of CSMA/CA in DCF) different for each TC, thanks to the introduction of a period called Arbitration InterFrame Space (AIFS).

IEEE 802.11p The purpose of this standard has been to provide interoperability between wireless devices attempting to communicate in potentially rapidly changing communications environments and in situations where transactions must be completed in time frames much shorter than the minimum possible with infrastructure or ad hoc IEEE 802.11 networks. Consequently, one of the specificities of this version is to reduce as much as possible transactional exchanges, notably the Basic Service Set (BSS) establishment step, which were nevertheless often necessary for the implementation of security at the MAC level. Typical targeted application of this standard is the Vehicular Ad-hoc Network (VANET).

IEEE 802.11n (Wi-Fi 4, 2009) This version mainly adds to 802.11a/g, a "Frame aggregation" mechanism at the MAC level. The objective is to reduce protocol overheads (for example, preambles, headers, and acknowledgments) and increase the throughput of users. As the name indicates, this "Frame aggregation" mechanism consists of sending blocks of frames in a kind of "super-frame", thus acknowledging it once. This block acknowledgment mechanism is similar to the one introduced in a previous version (IEEE 802.11e) called "Block acknowledgments".

802.11ac (Wi-Fi 5, 2013) 802.11ac is a more flexible form of 802.11n (Wi-Fi 4, 2009). An 802.11ac Access Point (AP) offers a dynamic throughput of up to 6.9 Gbps to a client under ideal conditions [6, 56]. From the MAC sub-layer perspectives, available throughput is increased thanks to *frame aggregation* and *per-frame channel and bandwidth selection*. The *frame aggregation* mechanism introduced in 802.11n is mandatory between exchanges of 802.11ac nodes. One rationale is to achieve more throughput by reducing protocol overhead due to preambles, headers, and acknowledgments of small data frames. The concept of *per-frame channel and bandwidth selection* is achieved through the enhancement of the RTS/CTS mechanism in order to negotiate maximum bandwidth. This mechanism is called *RTS/CTS with bandwidth indication*.

IEEE 802.11ax (Wi-Fi 6, 2019) This standard is built on the strengths of 802.11ac while adding a new level of flexibility and scalability to be more suited to crowded environments such as a crowded stadium or busy airport [34]. This is achieved through (i) an introduction of frequency multiplexing based access (similar to that of LTE/cellular) within the fundamental contention-based access framework of IEEE 802.11 (DCF) to re-

duce access latency, and therefore (ii) extensions to RTS/CTS procedures for multi-user to help avoid collisions with users using older single-user mode for a safe coexistence. To overcome the issue of co-channel interference in densification of massive Basic Service Set (BSS) deployment, IEEE 802.11ax adapts the mechanism of adaptive Carrier Sensing Threshold (CST) level, Adaptive Transmit Power (ATP) level, and BSS coloring [7]. 802.11ax includes a new feature called Target Wake Time (TWT) which conserves bandwidth and battery power through scheduling of short windows of engagement typically to assist energy resource-constrained IoT devices .

IEEE 802.15.4

IEEE 802.15.4 is a popular standard for implementing low-cost, short-range, low-power wireless networks with high deployment flexibility. It is designed for small-scale projects requiring a wireless connection, such as home automation, medical device data collection, and other low-power, low-bandwidth needs. The standard specifies the PHY and MAC layers.

In the MAC layer, a Carrier Sense Multiple Access with Collision Avoidance (CSMA/CA) scheme is used. Unlike the backoff procedure in DCF, a blind backoff algorithm is used. The rationale is to save power consumption of sensor networks that are in a difficult-to-access environment after deployment. Two types of CSMA/CA are specified for IEEE 802.15.4: unslotted and slotted, which depend on the number of Clear Channel Assessment (CCA) attempts after a backoff delay. Unslotted CSMA/CA performs one CCA of detection time equivalent to 8 symbols to report channel status as idle or busy. In contrast, slotted CSMA/CA performs a second CCA and reports an idle channel if the second CCA is also successful and busy otherwise.

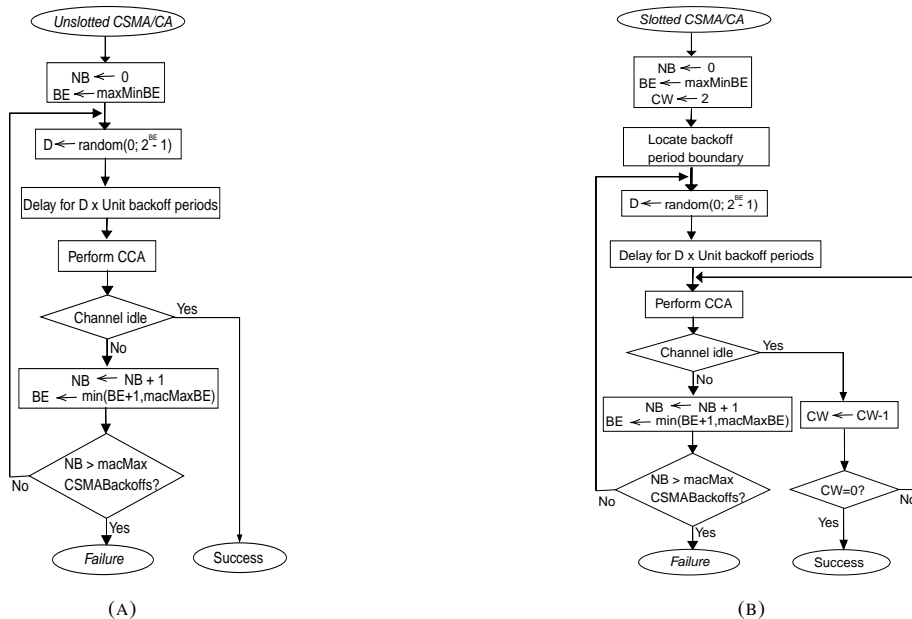

FIGURE 2.6 Flowchart of unslotted and slotted CSMA/CA algorithm in IEEE 802.15.4.

Figure 2.6b and 2.6a illustrate a simplified state machine of slotted and unslotted CSMA/CA process of IEEE 802.15.4 respectively. These algorithms start with the initialization of BE (Backoff Exponent) and NB (Number of Backoff of the current frame). BE is used to calculate the backoff interval $[0; 2^{BE} - 1]$ from which backoff values are randomly chosen. NB counts the number of transmission attempts of the current frame. Next, a random backoff D is chosen from the backoff interval. The backoff is decremented every backoff period slot of 320 micro second. Once it is fully decremented, one or two CCA tests follow depending on the version of CSMA/CA used. Unslotted version requires only one CCA test. If the channel is assessed idle, the frame is sent. Otherwise, BE and NB are incremented and a new backoff is chosen. The BE does not exceed $macMaxBE$ which is equal to 5 according to the standard. Also, when NB reaches $macMaxCSMABackoffs$, a fail to transmit indication is sent to the higher layer.

Slotted CSMA/CA is referred to as performing CSMA/CA while a superframe structure is in place for a beacon-enabled network deployment model. The unslotted CSMA/CA algorithm is used when there is no superframe structure for a non-beacon enabled network deployment model; consequently, no backoff slot alignment is necessary.

2.1.2 MAC protocols in cognitive radio environment

A Cognitive Radio system can be defined as a radio system that can sense and interact with its surrounding environment in order to adapt its behavior [14]. Thus, in heterogeneous networks where multiples technologies and applications are coexisting, the underlying system has to deal with the common aspects of CR system stages, where each stage of the system has its own set of design challenges. The challenges relates to *Spectrum sensing*, *Spectrum decision*, and *Spectrum sharing* [47].

The proposals of MAC protocols in CR environment can be seen as techniques to share radio resources at the MAC sub-layer between two categories of network users: Primary Users (PUs) and Secondary Users (PUs). The Primary Users (PUs) have priority to access to a given spectrum portion, and Secondary Users (PUs) have lower priority than the PUs. Most of the MAC protocols in the CR environment are designed for opportunistic spectrum access by SUs in an environment of PUs. There are various MAC proposals in the literature related to CR theory [19, 22, 47]. Nevertheless, the standardization efforts in cognitive MAC protocols remain particularly challenging; the common proposals target specific scenarios. In the following paragraphs, we will discuss the mode of operation of some representative proposals.

CSMA in cognitive radio networks

A CSMA/CA-based MAC protocol is proposed by [39] to enable the coexistence of a network of PUs and a network of SUs, but with possible interference between them. The network of SUs called Cognitive Radio Network (CRN), and the network of PUs called Primary System (PS) are infra-structured networks, where PUs and SUs are associated with their respective Base Stations (BS). There are only data transmissions from subscribers to BSs, and each BS defines and adapts its subscribers' modulation and coding scheme during the handshake data transmission procedure. Under the following assumption that all interferences caused by RTS (Request to Send) and CTS (Clear to Send) packets can be mitigated by a robust forward error correction code, the medium access scheme is as follow: PUs contend with CSMA/CA with RTS/CTS handshake to transmit their data after the waiting period τ_p . To transmit their data, SUs wait for the period τ_s , where $\tau_s \gg \tau_p$, and also use CSMA/CA with RTS/CTS handshake, with two modifications: (i) if the channel is occupied by PUs after τ_s , a SU still sends its RTS packet. (ii) If its BS receives an RTS packet, the BS computes the feasible transmission

power and rate and replies in consequence with a CTS if the transmission is feasible without causing data loss for PUs.

With this model of access scheme and the strong assumption of ignoring interference caused by all RTS/CTS packets, interferences can still occur to frames received by the PS BS during data transmission of the SUs [19].

Cognitive-MAC for Multi-Channel Wireless Networks

Cognitive-MAC (C-MAC) [18] proposal is based on synchronized time-slot and multi-channel MAC protocols. It aims to increase the overall throughput of the links and the robustness to spectrum changes implemented in a fully distributed manner. C-MAC supports the following features.

- *Inter-channel coordination*: there is no need for a dedicated common coordination channel. Each channel available is a potential one for coordination, called Rendezvous Channel (RC). It is dynamically selected and can change over time.
- *Distributed beaconing*: there is no need for a central device for beaconing, each device is expected to transmit and receive a beacon on the RC.
- *Load balancing*: using the RC, each network node shares its channel occupation information, and the channel selection algorithm at each node takes this into account for load balancing.
- *Coexistence*: in the C-MAC framework, every channel has two consecutive periods: Beacon Period (BP) and Data Transfer Period (DTP). During the DTP of each channel, there are quiet periods scheduled to sense the PUs.

The RC is initiated as follows. Upon power-up, a node starts by scanning all the channels to search for already initiated RC. If no RC is found, the node initiates one itself. Thus, it may have more than one RC in the network at a given time due to the distributed nature of the network.

The symmetric functioning of C-MAC could be summarized as follow. (i) During the association to the network, a node starts by searching the RC to know which node is located on which channel by analyzing the beacons received. (ii) Then, the node selects a channel and contends to get a permanent slot chosen among the first two slots of the BP of the channel (these two first slots are reserved for this purpose). (iii) If the node does not select the RC (probably for the sake of load balancing), it still periodically visits the RC to get resynchronized and for multicast or broadcast diffusion. One of the drawbacks

of C-MAC is that all beacons of network nodes must fit within the BPs of a superframe, limiting the proposal's scaling factor.

2.1.3 MAC protocols orchestration

MAC protocols are usually designed to optimize specific network scenario conditions. We call architecture for MAC protocols orchestration, literature proposals trying to build a system that can dynamically choose a specific MAC protocol suited to specific network conditions. Thus, these architectures can be seen as proposals that share several MAC protocols between the nodes of a network. Each proposal has its definition of network condition, but the following assumptions are common: (i) a network node may have several MAC protocols, (ii) each MAC protocol is more suited for a specific network condition, (iii) and the network condition can change over time. In the following paragraphs we will discuss the mode of operation of some of these proposals.

Meta-MAC protocols

Inspired by the computational learning theory and machine learning techniques, authors in [25] are among the first to propose a framework to coordinate a broadcast channel with an automatic selection of MAC protocols. In their framework, there is no need for any coordination or message exchanges. A network node decides locally to transmit a frame or not during a time slot. The node is assumed to have perfect "feedback" about its previous transmission decision at the end of each slot. The feedback is a binary variable that tells the node whether or not its previous decision was "correct" or "incorrect". Each node relies on its feedback to locally update a trust coefficient for each of its MAC protocols. These coefficients are initiated at system startup and decrease for a MAC protocol when decisions are incorrect.

According to our knowledge, there is no implementation of this theoretical framework, apart from an attempt in [21].

MAC Protocol Service

In [36], the authors made a proof of concept of a centralized framework architecture that can dynamically change a MAC protocol. The change is based on some QoS constraints of the supported applications in the network. In their framework, the central node has three software components. (i) An *Analyzer* which periodically gets QoS in-

formation of running applications (e.g. latency bound and Packet Error Rate) and system information (e.g. channel state information and the number of connected devices). (ii) A *Protocol Engine* which gathers information from the *analyzer* to set the parameter values of a Linear Optimization Problem (this LOP is built and used offline) and solves the LOP in order to select the optimal MAC protocol. (iii) A *Protocol Realizer* which parses protocol reconfiguration information received from the *Protocol Engine*. Then, it reconfigures the protocol stack of the central node, and through a dedicated channel, forwards reconfiguration information to the *Protocol Realizer* deployed on other network nodes, which in turn reconfigure their protocol stacks.

A practical use case of this framework is a connected home where the central node of the architecture could be a smartphone controlling sensors and actuators.

MAC protocol selection based on machine learning

With fewer concerns on actual deployment requirements, authors in [57] reported a framework of prediction of a proper MAC protocol (e.g., competitive or non-competitive) given network load conditions with machine learning techniques. The proposed prediction model is based on a support vector machine training algorithm (Sequential Minimal Optimization). The model is trained with data set collected through extensive simulations by varying Network Parametric Features such as the number of nodes, data rate, inter-arrival time and packet length, and the associated Network Statistics Features such as average load and throughput.

A practical use case of this model can be an infrastructure network, where the central node has complete and real-time knowledge of the network conditions and ideal wireless channels.

In this perspective towards MAC protocol orchestration architectures, there has been plenty of work on software-based implementation of the MAC layer in the paradigm of Software Defined Radios using Field-Programmable Gate Arrays (FPGAs) Circuits typically [20, 31, 78]. These implementations offer flexibility compared to hardware-specific implementations. Nevertheless, the main argument in favor of adopting hardware-based approaches instead of FPGAs has long been the fact that software-based implementations fail to achieve timing requirements, resulting in poor performance [30, 63].

2.1.4 IEEE 802.15.4 and IEEE 802.11 coexistence optimisation

ZigBee adopts IEEE 802.15.4 PHY and MAC layers, and Wi-Fi adopts IEEE 802.11 PHY and MAC layers. Both Wi-Fi and ZigBee have amendments that operate in the 2.4 GHz Industrial, Scientific and Medical (ISM) band with overlapping channels. The coexistence of these two technologies causes significant problems for ZigBee devices [12, 76] typically used for smart home automation and smart metering. This is partly due to the high transmitting power of IEEE 802.11 devices, set to a maximum of 100 mW, whereas IEEE 802.15.4 devices have maximum transmitting power of 1 mW. Due to their higher transmit powers and data rates, IEEE 802.11 networks cause significant inter-technology interference to IEEE 802.15.4 devices, especially in densely populated urban areas. IEEE 802.15.4 devices must therefore implement various interference mitigation and avoidance strategies to coexist with these networks in the same 2.4 GHz band. In what follows, we review the proposals for channel efficiency in IEEE 802.15.4 coexisting with Wi-Fi. We identified three types of proposals in the literature: (i) Wi-Fi interference prediction and avoidance based mechanisms, (ii) Zigbee operating channel control based mechanisms, and (iii) Interference detection and cancellation based mechanisms.

i) Wi-Fi interference prediction and avoidance mechanism for IEEE 802.15.4 based networks are proposed in [13] and [58]. In [13], authors propose a stochastic model for predicting and avoiding Wi-Fi interference in a ZigBee network, where the operation of ZigBee devices is modeled as Markov processes. It provides a link prediction mechanism in a single-channel Zigbee network. Results indicate that as the load on the Wi-Fi network increases, throughput increases and power consumption decreases in the ZigBee network, causing longer access delays as well. The proposal in [58] is an adaptive packet delivery algorithm for instructing ZigBee nodes based on a Wi-Fi channel idle state indicator metric built from a power-law distribution model.

ii) Frameworks for avoiding Wi-Fi interference in multi-channel ZigBee networks are proposed in [50, 69, 71]. The proposal in [71] consists of a centralized channel ranking and allocation mechanism based on relative received signal strength indicator and a throughput estimation for smart home applications. The proposal in [50] intends to maximize packet delivery of the ZigBee network by controlling the operating channels for both Wi-Fi and Zigbee networks using a dedicated synchronization channel. The proposal in [69] is a frequency hopping scheme for sensor networks based on IEEE 802.15.4

standard. It is a centralized mechanism in which a network coordinator decides on the hopping patterns taking into account Wi-Fi interference in order to maintain a regular throughput. Overall results indicate that considering interference of Wi-Fi channels in initialization and deployment of IEEE 802.15.4 based sensor networks benefit the performance of the network.

iii) Unlike above proposals built on top of a medium access control layer, proposals in [35, 61, 77] tackle the coexistence issue of IEEE 802.15.4 and Wi-Fi from the physical layer perspective through interference cancellation instead of avoiding them. Technique called ZIMO in [77] is a Wi-Fi signal interference cancellation mechanism using Multiple-Input and Multiple-Output (MIMO) techniques. A framework called DOTA in [61] also exploits MIMO techniques for interference cancellation of both Wi-Fi and ZigBee signals. The proposal in [35] combines MIMO techniques (for interference cancellation) with a busy-tone multiple access method [66] as a coexistence framework of IEEE 802.15.4 and uncooperative Wi-Fi users. The main drawback of these techniques is the need for MIMO antennas which are not widely available on ZigBee devices mainly for energy efficiency reasons.

Table 2.1 summarizes the approaches of the proposals together with their main Advantage and limitations.

TABLE 2.1 Summary of related work toward channel efficiency in IEEE 802.15.4 coexisting with IEEE 802.11.

Reference	Approach	Advantage for ZigBee network	Disadvantage / Limitation
Chong et al. [13]	Wi-Fi interference prediction and avoidance	Throughput and power consumption improvement	Additional access delay
Qin et al. [58]			Model accuracy relies on specific Wi-Fi traffic patterns
Vikram et al. [71]	Operating channel control based framework	Throughput and access delay improvement	Requirement of coordinator and synchronization channel
Nishikori et al. [50]		Throughput improvement	
Umer et al. [69]			
Kim et al. [35]	Interference detection and cancellation	Frame detection accuracy improvement	Requirement of additional module with unconventional ZigBee transceivers
Shao et al. [61]		Frame detection accuracy and throughput improvement	
Yang et al. [77]		Throughput improvement	
Ping et al. [38]		Impairment of Wi-Fi throughput	

We note that existing contributions for enhancing IEEE 802.15.4 and IEEE 802.11 coexistence are based on modifications of access methods or channel allocation mechanisms without taking into account information that could be provided from both technologies.

2.1.5 Mechanisms to improve resource efficiency in coexistence scenarios: opportunities and open issues

In Internet Exchange Points (IXP), many Internet Service Providers (ISP) share the same routing and switching infrastructures for cost efficiency. One can also imagine such resource sharing applied to network infrastructures in a dense urban environment

for the sake of spectrum and resource efficiency in addition to cost benefits. In order to efficiently allow heterogeneous networking technologies to coexist in connected city environments through such a resource-sharing concept, we consider the following scenario. A roundabout with a Road Side Unit (RSU) broadcasting the states of the traffic lights and a connected vehicle approaching this roundabout retrieves the states of traffic lights to pass with the optimal speed through a dedicated network interface. A gas station is situated near this roundabout with a wireless sensor network deployed for monitoring the station infrastructure and a public hotspot deployed for visitors. The wireless sensor network produces valuable information for nearby cars about the availability of each fuel type, the prices, and the average time spent at the station. The sensor network can be seen as a set of resources that can serve the C-ITS network and provide additional and needed information for nearby or interested vehicles. Thus, in a resource-sharing context, the sensor network and the C-ITS platform can agree on network elements to be shared, such as data, channels, and relay nodes.

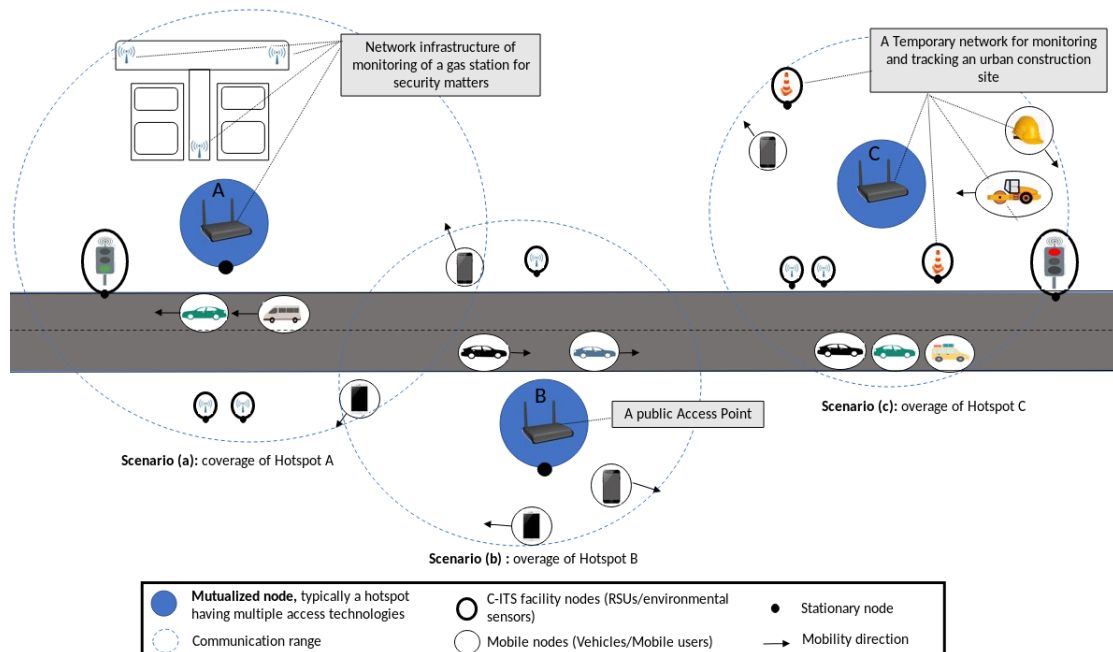

FIGURE 2.7 Network deployment scenario implementing a resource sharing approach in a typical dense urban environment, where the resources of several hotspots having multi-access technologies are pooled by other nodes in the vicinity such as connected vehicles, surrounding sensors or mobile users.

The extended scenario is depicted in figure 2.7. *Scenario a* in figure 3 represents a hotspot A that acts as a gateway for different types of network devices. In this scenario, suppose that: the sensors use 802.15.4 technology to exchange with the hotspot, the

RSUs use 802.11ah technology to exchange with the hotspot, and the mobile users implement various 802.11 standards (e.g., $n|ac|ax$). Thus, in this use case, the impact of network access offloading through the Mutualized Hotspot A (MH-A) having multiple access technologies on the performance of application profiles of the network is a main investigation.

Deployment of additional local management components within the MH-A may serve as (i) to reduce interference between these heterogeneous networks, (ii) and better control and globally guarantee the QoS constraints of the applications from these different networks. Hence, this may lead to a more global efficient coexistence and usage of the resources. A proposal aiming to optimize such a resource sharing approach has to deal with the following issues:

1) the MH-A should be able to maintain an up-to-date table indicating the technology capabilities of nodes. 2) The MH-A should be able to associate a cost for each access technology dynamically. For example, this cost can be related to the data rate or the packet loss associated with each technology at the transmission time. And, 3) the MH-A should also be able at a given time to detect the access technologies that could cause harmful interference to each other.

In order to maintain the table indicating the access technology capabilities of neighboring nodes, the MH-A could build and rely on the communication statistics of its associated devices. When the QoS constraints are defined as a simple requirement of throughput levels, the MH-A could rely on the different data rates of the standards (Modulation and Coding Schemes) to associate a cost dynamically to the access technologies.

A more general use case of a resource sharing approach would be the mutualization of the three hotspots (A, B, and C) of the figure 2.7 by all the nodes in the vicinity (e.g., connected vehicles, surrounding sensors, and mobile users). Thus, this deployment scenario implementing a resource sharing approach may allow to increase the connectivity of the network nodes and to avoid harmful interference between the devices through common radio management techniques between the hotspots [74]. This may lead to a more efficient coexistence and usage of the network access resources. However, the following issues remain open.

A universal framework: the question is to know the scenarios (e.g., expected node density, coverage needs) in which to add more such mutualized hotspots or to add mobility to some of them. For example, for the vehicles in figure 3 *Scenario b*, when leaving the

coverage of the (fixed) access point B and before reaching the coverage of the (mobile) access point C, delay-sensitive applications on these vehicles (such as a critical control application for monitoring/controlling automated vehicles) may fail to meet their Quality-of-Service (QoS) requirements due to lack of coverage. A proposal for such a framework should, therefore, take into account the usual strict requirements of reliability and latency of communication scenarios.

Access technologies and choice mechanism: the question is to know the appropriate technologies to deploy within the mutualized hotspots and the technique of constantly choosing one instead of another to maximize the access resources' global efficiency. These are the main research questions considered in thesis.

Coordination and centralization: in order to have an optimal mutualization strategy, there must be a kind of coordination between the nodes and especially those that have mutualization abilities and intelligence, such as the hotspots in our example. This coordination may not always be possible due to different owners and access providers of these hotspots.

Preconfigured sharing strategies: having a classification of application profiles will help to answer the QoS of each application according to its priority. Having a complete list of application profiles is almost impossible to achieve, but one can imagine categories of applications and a universal classification. This can be compared to the effort made in Class of Service types of IEEE 802.11e. Extending this to multiple technologies remains a challenge and an open issue.

Availability: in order to achieve mutualisation, there must be resources available to be shared. Hence, owners of resources should adhere to this concept in order for this concept to be feasible. This can be encouraged by governments and financial bodies by supporting providers and solutions that are open for sharing.

Security: confidentiality, authentication and integrity of data should be guaranteed from end to end in the process of resource sharing. Thus, rethinking security protocols in such a way to allow negotiation of security elements between heterogeneous nodes and standards would be the next step towards harmonizing security mechanisms.

Efficiency evaluation and experimentations: in the typical vehicle to everything networking environment of figure 2.7, performance evaluation of the protocols are usually made through computer simulations because of the cost and the difficulty of putting in place large scale field tests. To the best of our knowledge, no simulation platform models and brings together the available access technologies expected in the 5G and beyond networking paradigm.

2.2 Access Technology Selection mechanisms in heterogeneous networks

Access technologies are fundamental networking assets and are commonly designed to optimize network performance in a given context. Meanwhile, the high demand for mobile traffic and the diversity of future applications in the 5G paradigm motivate current communication techniques' evolution and revolutions toward ubiquitous radio access. Thus, massive deployment of base stations and access points of different Radio Access Technologies (RATs) is required to achieve robust and reliable connectivity solutions and seamlessly connect all devices. When a new session or handover session arrives in these heterogeneous networks, a decision must astutely be made as to which technology it should be associated with. This is called RAT selection. Overall, there are two main approaches to tackle this problem: centralized and decentralized. Depending on the Decision-Maker (DM) location, a centralized approach can be either network-centric, user-centric, or a collaborative architecture (a combination of both)[55]. These centralized approaches are the most straightforward to apprehend the issue of RAT selection since the problem can be formulated as a centralized optimization task (e.g., using linear and nonlinear programming models) whose objective is to maximize throughput, or equivalently, minimize the delay [33]. In decentralized or non-collaborative approaches, mobile users try to improve their performance by themselves, without a central coordinator, generally using heuristic rules. Our approach is of the later type. This has the advantage of not requiring network infrastructure and extra signaling for coordination that is usually required in centralized approaches.

In the network-centric approach, decisions are made at the network side with or without assistance from the user terminal. The network operators generally control such decisions. The before-mentioned approach is generally based only on the operator's profit, even though some user requirements may be considered before making a decision. As for user-centric approaches, decisions are made at the user terminal, and they are based only on the user's profit without considering network load balancing or

other users. Thus, the network may quickly reach congestion peaks, resulting in quality degradation of ongoing communications. In contrast to the network-centric approach, the user-centric approach can take advantage of the available access networks independently of the network operator. Despite this flexibility, the user-centric decision does not guarantee the efficient use of network resources due to its limited knowledge about network conditions. In [59], a user-centric and context-aware architecture to improve user-experience is proposed. The proposal's effectiveness in terms of the adaptability of the architecture and its capability to deal with contextual information changes is shown.

In the collaborative approach, both the network and the terminal are involved in the decision-making process. An example of a collaborative approach is the IEEE 802.21 Media Independent Handover (MIH) standard, which allows mobile devices and specific network entities to exchange information to facilitate the handover process between heterogeneous networks. In IEEE 802.21, centralized infrastructure support is required to assist the handover process between heterogeneous networks. For instance, network infrastructure can provide information about different access technology's performance, while the mobile terminal can handle applications requirements and decision-making. However, the design of a decision-maker, which strictly works in a collaborative approach, is inherently limited when the user or the network infrastructure cannot provide the information expected by the decision-maker. Using fuzzy logic, the authors in [32] proposed an MIH-based framework to reduce handover failure probability. The obtained findings showed a reduction of handover failure probability by up to 75%.

In a centralized or a decentralized approach, the issue of RAT selection can also be formulated as a Multi-Criteria Decision-Making (MCDM) problem related to considered criteria [68]. Typical MCDM algorithms are Hierarchical Analysis Process (AHP), Fuzzy Analytic Hierarchy Process (FAHP), Technique for Order Preference by Similarity to an Ideal Solution (TOPSIS), and Entropy. In addition to these schemes based on MCDM, Artificial Intelligence-based algorithms have also been applied for this issue, such as Artificial Neural Networks (ANN) and Q-Learning. However, these so-called intelligent algorithms must be iterated many times by probabilistic and heuristic rules to obtain optimal results gradually. Without enough iterations, any intelligence of algorithms will not be reflected, undesirable, or even bad, results may yield. The RAT selection mechanism in this thesis is formulated as a MCDM problem. Indeed, compared to AI-based algorithms, MCDM algorithms are relatively straightforward without

any random factors in the whole runtime. They can obtain the definite result almost directly, relying only on their corresponding formulas rather than multiple loops. However, the results may be less optimal as they can quickly complete the decision process and select the best target network. In what follows, we provide a more comprehensive study on MCDM and AI-based decision methods for the network selection problem in the literature. We end the section with a discussion about common design challenges related to their applicabilities.

2.2.1 Multiple Criteria Decision Making based methods

We describe here representative decision-making algorithms without random factors in the whole runtime namely deterministic Multi-Criteria Decision-Making (MCDM). We end the section with a summary table of these proposals.

A RAT selection mechanism considering the user and the network context is derived in [27]. It adopts the Hierarchical Analysis Process (AHP) for weighing the importance of selection criteria and the Technique for Order Preference by Similarity to an Ideal Solution (TOPSIS) for ranking available RATs. The framework consists of a *context provider* collecting network information from a *context manager* and user preferences and status from a *context consumer* to apply mechanisms toward decision making for the target RAT.

A centralized algorithm that applies the TOPSIS method on network attributes and user preferences to rank network association alternatives WiMAX, LTE, or WLAN is proposed in [1]. Simulation results indicate that the proposed algorithm reduces handover failure probabilities compared to a network decision algorithm based on Received Signal Strength (RSS) only.

Authors in [79] propose a network selection algorithm combining three typical MCDM methods as follows. FAHP is first used to calculate subjective weights of network attributes (e.g., bandwidth) and subjective utility values of all alternatives of four traffic classes (conversational, interactive, streaming, and background). Then Entropy and TOPSIS are used to respectively get the objective weights of network attributes and the objective utility values of all alternatives. The most appropriate network, whose overall utility value is maximum and higher than the corresponding value of the current mobile terminal network, is selected for access.

Authors in [75] propose a utility function-based RAT selection mechanism taking into

account user preferences, channel state information, as well as network loads and service, cost into account. The mechanism consists of central modules that periodically collect and broadcast network loads as part of the input of a normalized user utility function taking into account the quality of service requirements per service. Then the network having the most significant utility function is selected for access.

The approach in [46] is motivated by guaranteeing QoS for different service flows with diverse QoS requirements. The authors propose a handover framework with QoS architecture with scheduling and admission control mechanisms in the MAC layer. The work proposed to extend the Media Independent Handover framework in the IEEE 802.21 standard by a cross-layer architecture with new modules in different layers and new service primitives to facilitate communication. Whereas in [33], an optimization approach to RAT selection problem using a linear programming model considering the downlink of a heterogeneous network with two broadband RATs (Wi-Fi and LTE) is first proposed. Then, heuristic approaches based on users' simple decisions that necessitate no signaling information are proposed.

Table 2.2 summarizes the proposals and their main approaches, features, and findings.

TABLE 2.2 Summary table of deterministic RAT selection methods

Reference	Decision Methods	Networks	Traffic classes	Criteria	Signaling message	Findings
[27]	AHP, TOPSIS	LTE-A, Wi-Fi	Baseline class	RSS, Network load, User velocity	Yes	Improvement of throughput and delay compared to another link quality based handover mechanism.
Continued on next page...						

Table 2.2 – continued from previous page.

Reference	Decision Methods	Networks	Traffic classes	Criteria	Signaling message	Findings
[1]	TOPSIS	WiMAX, LTE, Wi-Fi	Baseline class	Number of nodes associated, User velocity, Service price, RSS	Yes	Handover success probability is increased by considering multiple criteria compared to RSS only based method.
[79]	TOPSIS, FAHP, Entropy	GSM, UMTS, LTE-A, Wi-Fi	Conversation, streaming, interaction, background	Bandwidth, latency, delay jitter, packet loss rate, service price	No	Combination of the MADMs reduces vertical handovers and provides better QoS compared with existing hybrid algorithms.
[75]	Based on cost function	LTE, Wi-Fi	Voice, Streaming	Troughtput, Network load, Service cost	Yes	Load balancing and user throughput improvement compared with a baseline scheme.
[33]	An optimization approach	LTE, Wi-Fi	Baseline class	Troughtput, Network load, RSS	No	Proposed distributed algorithms give efficient results compared to the centralized optimal approach.
Continued on next page...						

Table 2.2 – continued from previous page.

Reference	Decision Methods	Networks	Traffic classes	Criteria	Signaling message	Findings
[46]	Cross-Layer architecture	LTE, Wi-Fi	Real time, background	Bandwidth, Delay, SNIR, user velocity	Yes	Conducted simulations demonstrate the effectiveness of the proposed cross-layer handover architecture.

2.2.2 Artificial Intelligence-based methods

We review here some Artificial Intelligence (AI) based network selection algorithms. We begin with a brief description of the operating principles of the algorithms. We then review the proposals and classify them into two main groups: Machine Learning (ML) and Swarm Intelligence (SI). We end this section by giving a classification and findings summary of the proposals.

ML-based solutions are divided into three main subcategories: (i) Supervised Learning (SL), (ii) Unsupervised Learning (UL), and (iii) Reinforcement Learning (RL). SL and UL are offline ML algorithms where the prediction model has to be built before use. Indeed, SL techniques learn on a labeled data set, providing essential elements that the algorithm can use to evaluate its accuracy on training data. In contrast to UL techniques that provide unlabeled data, SL algorithms attempt to make sense by extracting valuable features. In comparison, RL approaches are classified as online ML algorithms that differ from SL and UL in not needing learning data beforehand. SL is about how software agents take actions in an environment to maximize the notion of reward (i.e feedback).

To begin with, we review Artificial Neural Network (ANN) based techniques included in the SL subcategory. Many papers used ANN to predict the optimal network based on multiple input criteria. ANN algorithms are inspired by the biological neural networks that constitute human brains. Targeting the goal of achieving uninterrupted connectivity taking into account multiple criteria, authors in papers [4, 37], proposed ANN-based solutions. In paper [4], authors' findings showed an improvement of QoS performance compared to the traditional RSS-based scheme. Authors of [37] also showed the benefits of their ANN-based scheme in reducing the number of handovers.

Clustering is a UL technique also frequently used to resolve the network selection problem. In the context of wireless sensor networks (WSNs), papers [49, 65] used clustering techniques for decision-making in centralized architectures. Authors in [49] compared Grouped Vertical Handover (GVHO) scheme with traditional vertical handover for a single user where each mobile station selects the best network without considering the influence from other concurrent handover decision making users. GVHO scheme has been introduced to avoid simultaneous decision-making for mass handover users. Paper [65] proposed a centralized solution based on network classification. The authors' technique is based on a clustering method that aims to classify the network traffic and target low-cost and energy constraints. The method uses data mining with a QoS prediction algorithm to provide an optimal network data transmission for each device. Findings accomplished projected performance. However, the model is evaluated without using a realistic network simulation model implementing protocol stack features.

In [53] authors adopt the game theory to analyze the network selection problem where the focus is to design an efficient Multi-Agent Reinforcement Learning (MARL) algorithm to solve it. The algorithm is based on observing the performance of the selected network and the decision to give a reward or a punishment to this decision. Experimental result demonstrates the effectiveness of the proposal in increasing throughput performance.

In an attempt to resolve the radio access technologies selection in 5G HetNets, authors in paper [48] proposed an ML-based framework where the throughput is the primary objective function. The authors tackled the problem of determining which RAT standard and spectrum to utilize and which Base stations or users to associate within the context of 5G HetNets. The proposed framework combined different machine learning algorithms. It uses feature vector clustering to build a system state model, supervised classification to obtain the current system state, and reinforcement learning to learn an effective policy using a Q-learning algorithm. The authors' proposal learns simple state representations out of the terminal experience and user behavior, and it also allows a multi-objective optimization of the association decisions while incurring minimal network overhead. Matlab simulations showed the benefits of the proposed framework compared to alternative decision methods in a multi-agent environment.

Authors in paper [26] proposed a hybrid intelligent handover decision algorithm primarily founded on two main heuristic algorithms: Artificial Bee Colony (ABC) and

Particle Swarm Optimization (PSO) named ABC-PSO to select the best wireless network during the vertical handover process. The authors considered single and multiple attributes cases to minimize the expected total cost and the average number of unnecessary handovers. The authors' numerical results demonstrated that ABC-PSO achieved lower cost, delay, and the number of handovers, higher available bandwidth compared to the related work. Ant Colony (ACO) based handover decision method is proposed in [24] to select the most suitable network in terms of QoS for mobile users. ACO algorithm uses similar agents called artificial ants that have the same properties as real-life ants, which tend to follow the highest pheromone concentrations in group. The proposed mechanism minimized the number of handover failures and unnecessary handover between cellular networks and WLANs while offering better QoS with less cost and power consumption.

Table 2.3 summarizes the proposals and their main approaches, features, and findings.

TABLE 2.3 Summary table of Artificial Intelligence-based RAT selection methods

Reference	Learning technique	Networks	Traffic class	Criteria	Findings
Supervised learning					
[4]	Neural Network Based Handover Management Scheme (NNBHMS)	LTE WiMAX Wi-Fi	Real-time, and Data services.	Data rate, coverage, Mobility, BER, Cost, and packet process	QoS enhancement.
[37]	Learning Vector Quantization Neural Networks (LVQNNs)	LTE WLAN	Multimedia	RSSI, Bandwidth, mobile speed, monetary cost	Handover reduction and network usage increase.
Unsupervised learning					
Continued on next page...					

Table 2.3 – continued from previous page.

Reference	Learning technique	Networks	Traffic class	Criteria	Findings
[65]	Fuzzy c-means clustering	WSNs	Web usage	QoS	Low energy and low cost constraints are targeted.
[49]	Fuzzy clustering	General context of HetNets	Real-time, Non real-time	Data rate, delay, affordable cost	Handover blocking probability reduction.
Reinforcement Learning					
[53]	Multi-armed bandit	IEEE 802.11 ac/n LTE	Base line	Throughput, delay	Throughput increase with experimental demonstrations.
[48]	Q-learning based framework with clustering and classification process	5G multi-rat architecture	Base line	Throughput, number of users	Low overhead.
Swarm Intelligence					
[26]	ABC-PSO	LTE, WiMAX, Wi-Fi	Streaming, Conversational	QoS	Lower cost and delay, higher available bandwidth and less number of handovers.
Continued on next page...					

Table 2.3 – continued from previous page.

Reference	Learning technique	Networks	Traffic class	Criteria	Findings
[24]	Update version of ACO	4G, Wi-Fi	Base line	Available bandwidth, monetary cost, security level, power consumption, and RSS	Better bandwidth Less cost and power consumption.

2.2.3 Challenges and key issues

There are several open issues in answering how a user should select an access technology at a given time while guaranteeing application needs and efficiently utilizing network resources in HetNets. In the following paragraphs, we will discuss these open issues according to a taxonomy of Multi-Criteria Decision-Making methods and AI-based methods.

Multi-Criteria Decision-Making methods related issues

Typical Multi-Criteria Decision-Making (MCDM) algorithms currently available are the Simple Additive Weighting (SAW) method, Analytic Hierarchy Process (AHP); Technique for Order Preference by Similarity to the Ideal Solution (TOPSIS) Multiplicative Exponent Weighting (MEW). Each of these algorithms has its advantages and disadvantages, and none can solve all MCDM problems perfectly so far [68]. Hence, the question related to choosing one MCDM instead of another is among the number of first challenges to consider in using MCDM in the context of RAT selection.

In the context of RAT selection and MCDMs, different types of applications such as conversation, streaming, interaction, or background traffic may simultaneously be considered together with different attributes such as bandwidth, packet jitter, packet loss, or service cost. Thus, how to astutely define dominant attributes while considering user preferences remains also challenging. This issue refers to the notion of prioritization of decision criteria for each application profile.

Another issue of MCDM methods relates to estimating the performance of access technologies based on decision criteria (e.g., throughput, delay, loss rate, etc. A de-

cision based on very recent or very old criteria data could lead to underestimating or overestimating, resulting in undesirable or wrong decision-making. Furthermore, supported application types should be considered in estimating the performance of access technologies since different applications may give different network metrics. For example, criteria such as packet loss rate, which can be obtained using acknowledgment of unicast applications, cannot be considered using broadcast applications.

Artificial Intelligence-based methods related issues

Limitations of offline machine learning techniques such as SL and UL manifest in two aspects: lack of data and good data. In fact, if the training model is poorly fed, it will give inaccurate results. Hence, these techniques require large amounts of quality data before they begin to give valuable results. The quality of data is a crucial factor affecting the efficiency and accuracy of these learning techniques. Indeed errors in training data might confuse the algorithm and lower its accuracy. Collecting and labeling data is also a time-consuming task. In addition, the training set needs to cover different network performance situations to avoid modeling a decision based on specific use cases.

RL generally uses Markov Decision Process (MDP) and game-theory, convergence to an optimal solution is not always guaranteed and may be complexity prohibitive. Searching for and finding the optimal solutions is cumbersome, especially in the case of large network topology. Formulating the network selection as an optimization problem with low or moderate computational complexity is not a trivial task and can be, in some cases, NP-hard problem [60]. These so-called intelligent algorithms require an iteration phase before the desired results are obtained since fast convergence is not always ensured. Thus, powerful engines and High-Performance Computing (HPC) are essential to minimize the runtime of these algorithms and fit the constraints of handover in terms of latency and quality of user experience.

2.3 Conclusion

We presented and discussed in this chapter techniques of wireless resource sharing in the literature and discussed opportunities and open issues. The discussed methods are in standard technologies and MAC protocols and MAC protocols adaptation proposals in Cognitive radio environment. We also discussed proposals of optimization of the case of IEEE 802.15.4 and IEEE 802.11 coexistence.

An opportunity for heterogeneous coexistence is a resource-sharing framework that

positively impacts network infrastructure for better spectrum efficiency. The related challenges are resource availability and implementation of a universal framework, security, and access technology selection. Issues related to access technology selection are the main research questions considered in this thesis. We presented and discussed some representative work on these issues, categorized as Multiple Attribute Decision Making based methods and Artificial Intelligence-based methods. The current work focuses on the decision algorithm without specifying how the user could prepare the decision data or objectively quantify the QoS constraints of its applications. This is our rationale to design in what follows a complete framework for RAT selection in wireless networks in addition to a mechanism of IEEE 802.15.4 and IEEE 802.11 coexistence optimization.

CHAPTER 3

CONTRIBUTIONS

In this chapter, we present and discuss the methods of the actual thesis contribution. In Section 3.1 we present and discuss the methods for our contribution on Radio Access Technology (RAT) selection in heterogeneous networks namely DURATS. In Section 3.2 we present and discuss the methods for our contribution on IEEE 802.15.4 MAC and IEEE 802.11 coexistence, namely "IEEE 802.15.4 MAC aware of WLAN".

3.1 Distributed User-centric Radio Access Technology Selection framework: DURATS

This section presents the different components of the DURATS framework. To proceed, we first discuss design rationales, and the assumptions of RAT selection problem modelization in the DURATS framework in Section 3.1.1 and Section 3.1.2 respectively. Then in Section 3.1.3, we give formal definitions of decision criteria considered in the DURATS framework. Next, we describe the decision process algorithm in Section 3.1.4, and the algorithm of data collection and decision criterion estimation (in Section 3.1.5). Finally, in Section 3.1.6, we describe the algorithm of RAT ranking based on the estimated criteria values.

3.1.1 Design rationales

We design a RAT selection mechanism, namely DURATS for Distributed User-centric Radio Access Technology Selection framework, to select access technology per application packet basis. This is called *radio interface selection*, and it is different from the classic access network selection, best known as *network selection* [54]. In heterogeneous networks (HetNet) where macro, micro, pico, and femtocell coexist, typical *network selection* approaches associate a cell with a newly arrived user session where the user dwells in the cell during the entire session unless a handover occurs. Thus, compared to *network selection*, *radio interface selection* guarantees that the application is constantly best connected.

Unlike the current work discussed in Section 2.2 that focuses on the decision algorithm without specifying how the user could prepare the decision data or objectively quantify the QoS constraints of its applications, the DURATS framework is a complete framework for RAT selection tackling the following three main is-

sues. (i) Estimation of the performance of access technologies based on decision criteria (e.g., throughput, delay, loss rate).

(ii) Quantification of the QoS constraints of the application profiles. This refers to the notion of prioritization of decision criteria for each application profile.

(iii) The actual decision algorithm for the assignment of application traffic to access technologies that takes into account the estimated criteria and their weights in the decision.

There are two approaches to access technologies performance estimation: analytical and empirical. Analytical methods are mainly based on access layer state variables of the technology (e.g., contention window). In contrast, empirical methods are mainly based on communication history. A common issue of analytical approaches is that they are criterion-specific for a given version of the technology, and therefore, are not general-purpose solutions [28]. Thus, we choose an empirical approach where the main issue relates to the control of traffic history. In fact, a decision based on very recent or very old criteria data could lead to its underestimation or overestimation, both resulting in undesirable or wrong decision making. We propose a mathematical framework for the control of traffic history detailed in the following subsections. To our knowledge, this is the first attempt to develop a decision data processing framework to control traffic history for RAT selection.

The quantification of the QoS constraints of the application profiles refers to the notion of weights of the decision criteria. There are two main categories of weights: objective and subjective [68]. Objective weights are used when the decision-maker lacks background knowledge or when the user or the operator does not have any special requirements. When supported, end-user applications have special requirements such as QoS, subjective weights are used. We propose a mathematical framework to derive subjective weights from QoS requirements of end-user applications objectively. To our knowledge, this is also the first attempt to develop an objective method of deriving subjective weights to consider the application's QoS requirements in the decision-making of RAT selection.

For the actual decision algorithm for the assignment of access technologies,

there are two approaches in the literature: centralized and decentralized, as discussed in Section 2.2 which can both be implemented using AI-based or MADM algorithms. Compared to AI-based algorithms, MADM algorithms are relatively straightforward without any random factors in the whole runtime. They can obtain the definite result almost directly, relying only on their corresponding formulas rather than multiple loops [42]. Thus, MCDM method is considered in the DURATS framework in the decision-making phase.

3.1.2 RAT selection problem model

We consider that a network node has a set of use case application profiles and a set of access interfaces. We assume that every access interface has its access technology, and every access technology has its access interface. Each application profile generates data where a functional module called *decider module* decides on the transmission interface based on local statistics. This is illustrated in Figure 3.1. The purpose of the *decider module* is to meet Quality of Service (QoS) requirements of the application profiles.

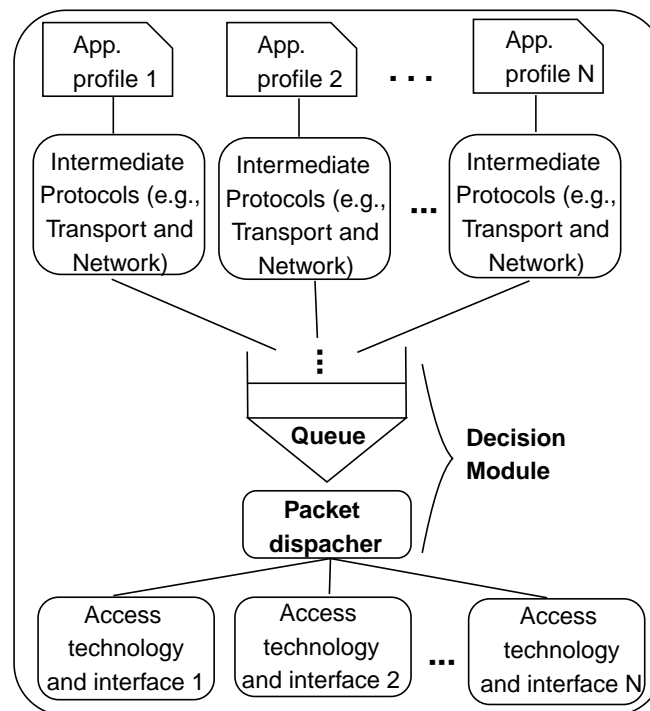

FIGURE 3.1 Architecture of DURATS enabled multi-interface network node.

An application profile $i, i = 1, \dots, N$, is characterized by a set of requirements in terms of network performance, such as minimum required throughput, maximum tolerated delay, and packet loss. For each of these requirements, we will associate a weight w_j , where $j, j = 1, \dots, M$ denotes the j^{th} criterion. Weights will be calculated based on a subjective method described in Section 3.1.6.

Access interfaces are characterized by criteria based on statistical observation of the network performance. These criteria are specified in Section 3.1.3. They are used by the *decider module* in order to choose the best suited interface given the application requirements of the current packet. We focus on use case application profiles that generate unicast traffic requiring acknowledgements for each generated frame.

3.1.3 Decision criteria

The DURATS framework considers three criteria in the decision-making process: Data Delivery Ratio (DDR), Throughput indicator, and Delay indicator. The rationale is that connecting an application to the best network implies usually choosing the one that maximizes its throughput while minimizing its delay and packet loss.

Data delivery ratio

Data Delivery Ratio (DDR) is the criterion that models link reliability between nodes per access technology. It is defined as the ratio between the number of data packets successfully sent *SuccessTransData* (for which the acknowledgement has been received) and the total number of data packets attempted to be transmitted *TransData* using interface $it, it = 1, \dots, I$ over anterior time interval bounded by δ_1 .

DDR is calculated using eq.3.1.

$$DDR_{it}^t = \frac{SuccessTransData_{it}^{[t-\delta_1, t[}}{TransData_{it}^{[t-\delta_1, t[}} \quad (3.1)$$

Throughput indicator

We consider the effective data rate as the throughput indicator on interface i at time t as expressed using eq. (3.2). It is defined as the ratio of the amount of data correctly sent by interface i observed over an anterior time interval δ_2 .

$$Th_{it}^t = \frac{SuccessTransData_{it}^{[t-\delta_2, t[}}{\delta_2} \quad (3.2)$$

Delay indicator

The transmission delay of a packet p using access interface i at time t is calculated based on two parameters:

- $QstayDuration_{it}^t$: an estimate of how long p remained in MAC layer queue starting from t until it reaches the top of the queue.
- $AccessDelay_{it}^t$: an estimate of the time it takes for the access procedure of interface i to send p on the medium at time t .

The transmission delay is defined in eq. 3.3:

$$D_{it}^t = QstayDuration_{it}^t + AccessDelay_{it}^t \quad (3.3)$$

where $AccessDelay_{it}^t$ and $QstayDuration_{it}^t$ are empirically estimated using collected data in $[t - \delta_3, t[$. The mechanisms for initializing and adjusting $\delta_1, \delta_2, \delta_3$, which we call Data Life Time (*DLT*), are discussed in 3.1.5.

3.1.4 Decision process

The goal of the decision process is to choose the current best access interface for an application profile based on a ranking of the access interfaces with defined criteria. For each data packet of an application profile, a functional decision module, called *decider module*, with two sub-modules *Queue* and *packer dispatcher*, chooses the transmission interface to use based on local statistics using Algorithm 1.

Algorithm 1: Access technology selection algorithm.

Input: Application packets *Queue*.

Result: Target access interface for each application packet.

```

1 Initialize Data Life-Times  $\delta_1, \delta_2, \delta_3$  ;
2 while Queue not empty do
3   Pop packet P from Queue;
4   Nets  $\leftarrow$  available network indexes ;
5   C  $\leftarrow$  networks attributes ;
6   DM  $\leftarrow$  PrepareNetAttributes(Nets, C,  $\delta_1, \delta_2, \delta_3$ );
7   targetNet  $\leftarrow$  rankIndex(DM, P_profile);
8   Assign P to targetNet ;
9 end

```

In Algorithm 1, the following steps are performed to assign an access interface to an application packet. **(Steps 4,5)** Alternative access networks are determined as well as the network selection criteria. **(Step 6)** *PrepareNetAttributes* is a procedure that prepares decision data in the form of a matrix called *decision matrix* (DM) considering Data Life-Time duration. The steps of this procedure are specified in 3.1.5. The decision matrix is constituted of values $r_{it,j}$ of the criteria of the different network alternatives, where it is the index of the alternative interface and j is that of the criterion. The *DLT* parameter per interface criterion is initialized by $f(0)$ at **(Step 1)** and is updated taking into account the fluctuation of the interface statistics as well as its utilization rate. **(Step 7)** The *rankIndex* method uses decision process which includes normalization of the decision data, the determination of criterion weight of current application (namely $P_{profile}$), as well as the ranking Algorithm. These steps are detailed in section 3.1.6.

3.1.5 Decision data processing

In the data-processing stage, criterion data is collected and processed based on the steps of the following paragraphs. This allows us to update *DLT* $\delta_1, \delta_2, \delta_3$ and to obtain the decision matrix.

At the time t of decision, criterion data-set of current network index is retrieved using it's *DLT* to control the freshness of the data. These data are statistic samples recorded and time-stamped in the background, either through data traffic or periodic control traffic. The network criterion's Coefficient of Variation (cv) is

calculated from its statistic samples to update its DLT . cv is a statistical measure defined as the relative variation to the mean of a given data [9].

A function f determines DLT based on the cv of the network criterion. This function aims to reduce the DLT when cv increases and to increase it when cv decreases. The rationale is to increase the update frequency of the decision matrix (by reducing DLT) proportionally to the instability of cv due to data fluctuation. Moreover, conversely, to reduce this frequency proportionally to the trend of data stability. The determination of DLT interval length by f must be controlled in the function to guarantee a minimal and maximal size of the decision matrix. Based on the above reasoning, f is a decreasing function of cv with asymptote δ_{min} , which can be obtained using exponential modeling. This is illustrated in figure 3.2.

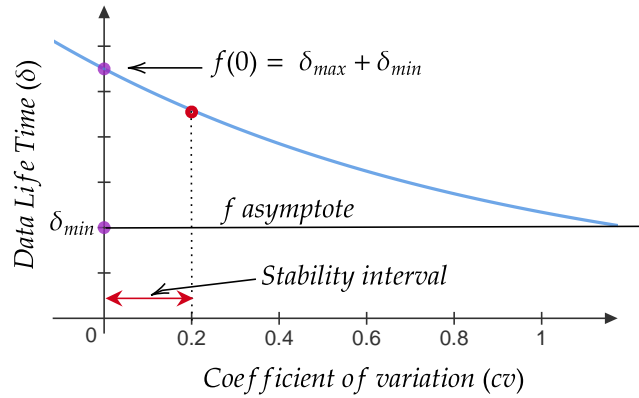

FIGURE 3.2 Data Life-Time ($\delta_1, \delta_2, \delta_3$) function.

For stable values of cv (e.g., $cv \leq 0.2$), DLT values need to be close to the image of 0 ($x = 0$). This condition can be satisfied when f graph crosses the y -axes to form a y -intercept point denoted as $f(0)$ that systematically gives the maximum DLT value denoted as δ_{max} , in addition to the minimum DLT denoted as δ_{min} as illustrated in Figure 3.2.

$f(x)$ can be modeled as a parametric function depending on δ_{max} and δ_{min} as given in equation (3.4).

$$f(x) = e^{-x + \ln(\delta_{max})} + \delta_{min} \quad (3.4)$$

For each interface, decision statistics are collected according to the transmission it makes. Thus, equation (3.5) gives the relationship between δ_{max} , the interface usage period τ , and statistic samples size γ . τ is proportional to data traffic going through the interface. The value of γ and δ_{min} should be controlled to avoid making decisions based on underestimated or overestimated data. These values should depend on the expectation of the network criteria dynamics; for example, their values would be small in a highly dynamic wireless environment.

$$\frac{\delta_{max}}{\tau} = \gamma \quad (3.5)$$

From (3.5) and (3.4) we derive eq. (3.6) as the Data Life Time function.

$$f(x) = e^{-x+\ln(\gamma*\tau)} + \delta_{min} \quad (3.6)$$

Exponential Moving Average (EMA) is then applied to each selected criterion data-set to form the decision matrix. EMA is a moving average that places a greater weight and significance on the most recent data points. The EMA of a series of data denoted as Y is recursively calculated as given in equation (3.7).

$$S_t = \begin{cases} Y_1, & t = 1 \\ Y_t = \alpha Y_t + (1 - \alpha)Y_{t-1}, & t > 1 \end{cases} \quad (3.7)$$

The coefficient α represents a smoothing constant between 0 and 1. A higher value of α allows faster discounting of older observations. Commonly, α is expressed by equation (3.8) to give the higher priority to the most recent value in the selected list of size n [10].

$$\alpha = \frac{2}{(n + 1)} \quad (3.8)$$

3.1.6 RAT ranking

In this section, we discuss Multi-Criteria Decision-Making (MCDM) steps used as the ranking algorithm. These steps include normalization and weighting methods, and we will also discuss the rationales of the considered methods for this

proposal.

Weighting: This step aims to determine the weight of each decision criterion according to an identified application App . The general form of the weight vector namely W_{App} is given by equation (3.9).

$$W_{App} = [w_D \quad w_{Th} \quad w_{DDR}]^T \quad (3.9)$$

We use the pair-wise comparison matrix method to objectively obtain subjective weights W_{app} . This method allows us to assess the relative importance of different criteria based on binary comparisons matrix A_{App} of $M \times M$ having the following form [23]:

$$A_{App} = \begin{bmatrix} a_{11} & \cdots & a_{1M} \\ \vdots & \ddots & \vdots \\ a_{M1} & \cdots & a_{MM} \end{bmatrix}, \text{ where } \begin{cases} a_{uu} = 1 \\ a_{vu} = \frac{1}{a_{uv}} \end{cases} \quad (3.10)$$

In (3.10), M represents the number of criteria. The a_{uv} values, such that $1 \leq u \leq M, 1 \leq v \leq M$ and $v > u$, are the relative importance degree of criterion u compared to criterion v for application App . Then, the Eigenvector or the Weighted Least Squares (WLS) method can be used to estimate the effective weight W_{App} of application App . In WLS method, the optimization problem for weights estimation can be formulated as follows [73]:

$$\min Z = \sum_{u=1}^M \sum_{v=1}^M (a_{uv}w_v - w_u)^2, \text{ s.t. } \sum_{i=u}^M w_u = 1 \quad (3.11)$$

In section 4.1.2, we give a numerical example of calculating a_{uv} values of pair-wise comparison matrix from specific use case applications, and we demonstrate how we extract the effective weights from the pairwise comparison matrices.

Normalization: This step eliminates dimensional data units in estimated decision data ($r_{it,j}$, $it = 1, \dots, I; j = 1, \dots, M$) to obtain numerical and comparable input data using a standard scale. We chose to use a linear normalization tech-

nique of eq. 3.12 that aims to eliminate the usage of absolute min-max values [29]. Illustrated in Figure 3.3, the method allows greater distance between an alternative's normalized values so that the ranking order will be clearer.

$$S_k^*(j) = \begin{cases} \frac{l_j}{S_k(j)}, & \text{for "smaller-the-better" criterion.} \\ \frac{S_k(j)}{u_j}, & \text{for "larger-the-better" criterion.} \end{cases} \quad (3.12)$$

In eq., 3.12 u_j is the maximal value of j^{th} criterion, defined as $\max\{S_1(j), S_2(j) \dots S_n(j)\}$, while l_j is the lowest value. "smaller-the-better" is associated to criterion we aim to minimize (such as delay), and "larger-the-better" is associated to criterion we aim to maximize (such as data rate).

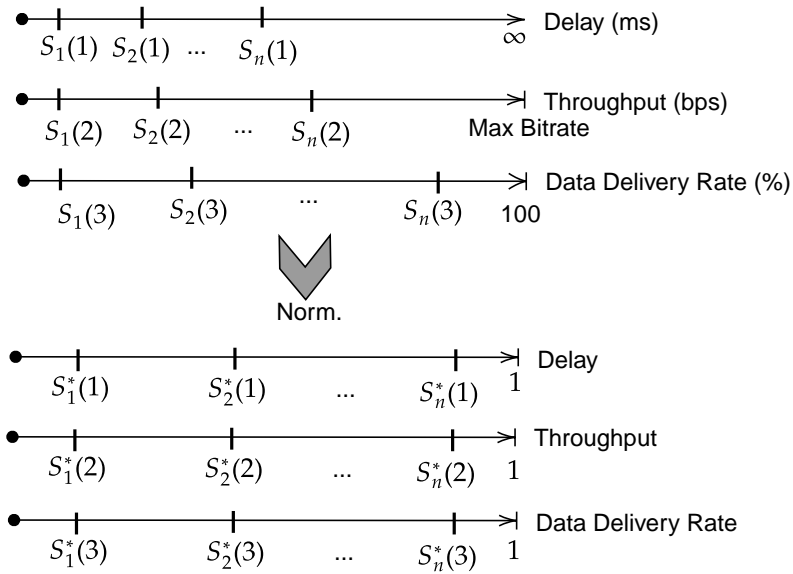

FIGURE 3.3 Illustration of three decision criteria normalization. It should be noted that the $S_k(j)$ are statistical samples that are not necessarily ordered on the scale.

This step results in normalized decision matrix of $r_{it,j}^*$ values where, it the index of the alternative interface, and j the index of the criteria.

Ranking: This step consists of establishing a rank of order for each alternative RAT, taking into account the normalized matrix and the weight of each criterion. Many techniques are available for the rank calculation [67]. We chose to ap-

ply Technique for Order Preference by Similarity to an Ideal Solution (TOPSIS). TOPSIS determines the best alternative based on the concepts of compromise solution. It is relatively simple and offers more accuracy in identifying the alternative rank compared to other MCDM algorithms [67].

TOPSIS algorithm involves the following steps [52].

1. Calculation of the weighted normalized decision matrix. The weighted normalized value $v_{it,j}$ is calculated as

$$v_{it,j} = w_j \times r_{it,j}^*, \quad it = 1, \dots, I; j = 1, \dots, M \quad (3.13)$$

2. Determination of positive-ideal and negative-ideal solutions using equations 3.14 and 3.15.

$$A^* = \{v_1^*, \dots, v_M^*\} = \{(\max_{it} v_{it,j} | j \in M'), (\min_{it} v_{it,j} | j \in M'')\} \quad (3.14)$$

$$A^- = \{v_1^-, \dots, v_M^-\} = \{(\min_{it} v_{it,j} | j \in M'), (\max_{it} v_{it,j} | j \in M'')\} \quad (3.15)$$

where M' is associated with benefit ("larger-the-better") criteria, and M'' is associated with cost ("smaller-the-better") criteria. "smaller-the-better" is associated with a criterion that we aim to minimize, and "larger-the-better" is associated with a criterion that we aim to maximize. Thus, *Delay* and *Data Delivery Ratio (DDR)* are considered as "smaller-the-better", while the *Throughput* is considered as "larger-the-better".

3. Calculation of separation measures, using the n -dimensional Euclidean distance. The separation of each alternative interface it from the ideal solution is given as:

$$D_{it}^* = \sqrt{\sum_{j=1}^M (v_{it,j} - v_j^*)^2}, \quad it = 1, \dots, I \quad (3.16)$$

Similarly, the separation from the negative-ideal solution is given as:

$$D_{it}^- = \sqrt{\sum_{j=1}^M (v_{it,j} - v_j^-)^2}, \quad it = 1, \dots, I \quad (3.17)$$

4. Calculation of the relative closeness to ideal solution. The relative closeness of the alternative it with respect to A^* is defined as

$$C_{it}^* = \frac{D_{it}^-}{D_{it}^* + D_{it}^-}, \quad it = 1, \dots, I \quad (3.18)$$

5. Ranking of the preference order, where the best alternative C^* corresponds to the index of the highest C value.

3.2 IEEE 802.15.4 MAC aware of IEEE 802.11

This section presents our proposals for enhancing IEEE 802.15.4 and IEEE 802.11 coexistence which benefits from a virtual Clear Channel Assessment (CCA) given by the Wi-Fi interface present on the same device. The proposals are two types targeting two typical types of applications.

3.2.1 Backoff mechanism 1 for delay tolerant applications

The first proposed enhancement of backoff mechanism is illustrated by the flow chart of Figure 3.5. The components in gray represent the difference with the standard CSMA/CA mechanism. The algorithm starts with the initialization of BE (Backoff Exponent) and NB (Number of Backoff of the current frame). Then a random backoff of delay D is chosen from the interval $[0; 2^{BE} - 1]$ as with the CSMA/CA mechanism. However, every time the node wants to decrement the backoff, it checks the availability of the channel by checking the value of the Network Allocation Vector (NAV) from the Wi-Fi for a virtual CCA operation. In case the channel is indicated idle by the NAV, the node decrements the value of D . Otherwise, the node refrains from decrementing its backoff until the end of the duration indicated in the NAV. Once this duration is consumed, the node resumes its backoff decrementation. Note that, since there is always a spacing between consecutive NAVs of at least IFS (Inter Frame Space), there is a guarantee that the backoff will reach zero eventually.

The purpose of this modification of the algorithm is to avoid decrementing the backoff if the channel is busy. We call this modification, *backoff mechanism 1*. This mechanism is inspired by the backoff procedure in DCF which decrements the remaining duration of the backoff only while the channel is idle known as the traditional backoff procedure. This mechanism has a drawback of making the node waits for a long period before sending the frame. This mechanism would reduce collision probability as WLAN load is increasing, but with increasingly longer access delays. Thus, it is suitable for applications where we want to avoid packet loss and we can tolerate delay.

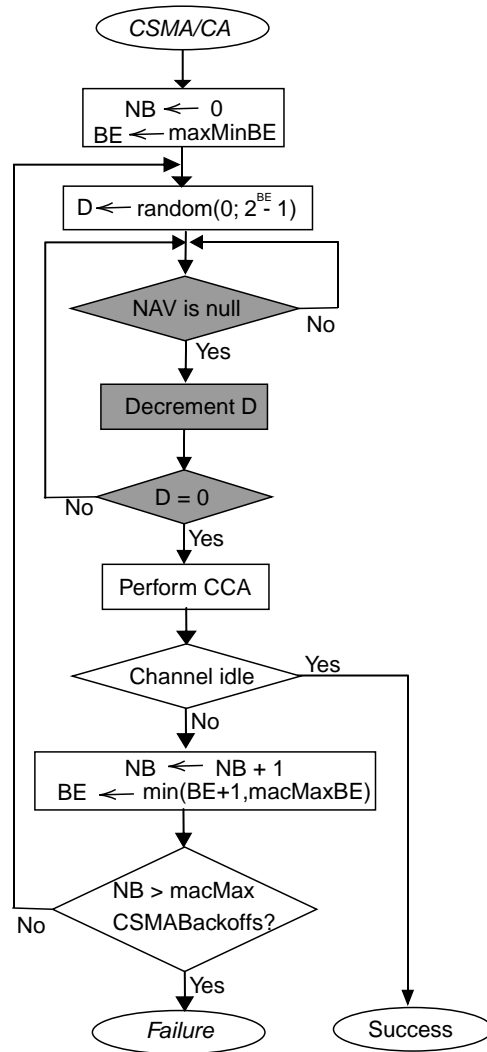

FIGURE 3.4 Flow chart of the extended CSMA/CA mechanism 1 in IEEE 802.15.4 to improve coexistence with IEEE 802.11.

3.2.2 Backoff mechanism 2 for non delay tolerant applications

The second proposal of the backoff mechanism is illustrated by the flow chart in figure 3.5. The components in gray represent the difference with the standard CSMA mechanism. The algorithm starts with the initialization of (Backoff Exponent) and NB . Then a random backoff of delay D is chosen from the interval $[0; 2^{BE} - 1]$. Then the node starts the backoff for this delay as with the standard CSMA/CA. However, when the backoff reaches null, the node checks the NAV first for a virtual CCA operation. Then, if the NAV indicates that the channel is busy, the nodes do not proceed to a physical CCA operation. Instead, it restarts the backoff for a delay equivalent to the previous value minus one backoff period. Thus, for every virtual CCA failure on the NAV, the node restarts a backoff with the same original value reduced each time by one and avoids the incrementation of BE and NB . Otherwise, if the NAV indicates that the channel is idle or after consecutive backoffs and virtual CCA failures equivalent to a number of the original value of backoff (.e.g. $D = 0$), the node continues as with the standard CSMA-CA. This by performing a physical CCA and incrementing of BE and NB consequently.

The rationale behind this mechanism is the following: the node continues decrementing the backoff while the NAV indicates that the channel is busy, thus avoiding the incrementation of BE and NB for additional competition. Indeed, mechanism 2 avoids sending the frame while the channel is busy and waiting for time and energy of retransmitting the frame in case of a collision (which is the most probable result when the NAV indicates that the channel is busy). This mechanism offers a trade-off between channel access delay and collision reduction. Thus, this mechanism would reduce delays at the cost of higher collision rates. Thus, it is suitable for applications that are more compelling delay and we can tolerate packet loss.

These two techniques for enhancing the coexistence of IEEE 802.15.4 and IEEE 802.11 do not require any inter network coordination between IEEE 802.15.4 and IEEE 802.11 contrary to discussed related work in the literature (in section 2.1.4)

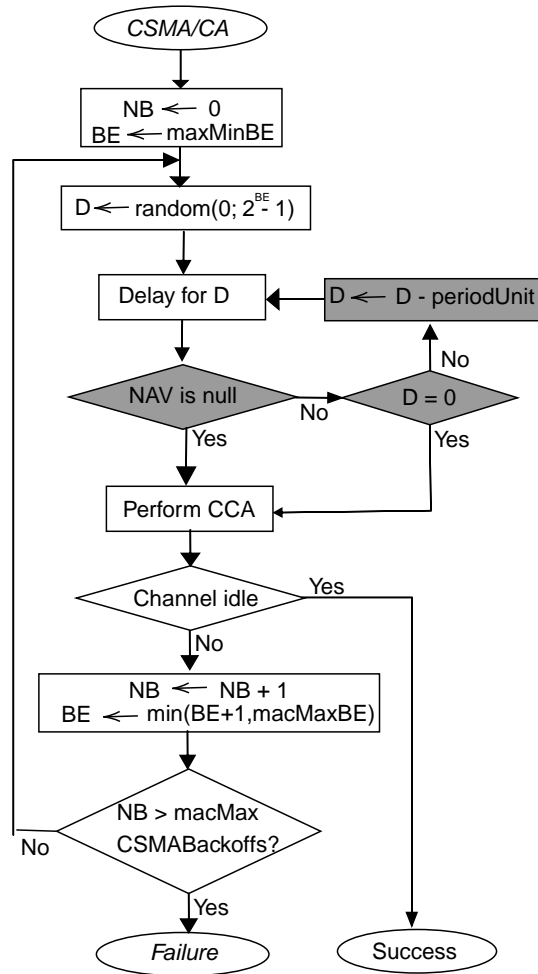

FIGURE 3.5 Flow chart of the extended CSMA/CA mechanism 2 in IEEE 802.15.4 to improve coexistence with IEEE 802.11.

and can be implemented locally on nodes thanks to a memory sharing mechanism between the interfaces.

CHAPTER 4

RESULT AND DISCUSSION

This chapter aims to discuss the evaluation method, the results and findings of our research. Thus, in Section 4.1, we present and discuss the evaluation scenario and the results for our contribution on Radio Access Technology (RAT) selection in heterogeneous networks namely DURATS as the first component of this thesis contribution. In Section 4.2 we present and discuss the evaluation scenario and the results for our contribution on IEEE 802.15.4 MAC and IEEE 802.11 coexistence, namely "IEEE 802.15.4 MAC aware of WLAN" as the second component of this thesis contribution.

4.1 Distributed User-centric Radio Access Technology Selection framework: DURATS

4.1.1 Simulation model

To evaluate the proposed model DURATS, we developed a new framework for heterogeneous network simulation through the integration of the popular, open-source, full-stack network simulation modules projects in the OMNeT++ ecosystem: INET and SimuLTE. INET is a package of standard IETF and IEEE protocols and is considered in this work for the IEEE 802.11 protocol model. SimuLTE is an LTE protocol model written for OMNeT++ [17] and considered in this work for the LTE D2D protocol model. We patched INET (v3.6.6) and SimuLTE (v1.1) in order to develop multi-interface nodes with decision module allowing seamless interface usage.

We consider three multimedia applications: Conversational (Conv), Streaming (Strea), and Interactive (Inter). Table 4.1 summarizes performance expectations of these use case applications from an end-user perspective in terms of delay, data rate, as well as information loss according to International Telecommunication Union [11]. The information loss metric is defined as the ratio of data received with errors to total data received, namely "frame erasure rate." Conversational application delay is the time limit for sending voice packets. The streaming application delay is the user's waiting limit for the beginning of his stream transfer. The Interactive application delay refers to the waiting threshold between the moment the user interacts with his equipment (e.g., click on a web link) and the server

response.

We assume that these performance expectations of delay, data rate, and information loss are respectively assimilated to our delay, throughput, and DDR metrics. Based on these performance expectations, in what follows, we explain how we calculated the weights for our Multi-Criteria Decision-Making (MCDM) model.

TABLE 4.1 End-user performance expectations of some multimedia applications [11].

Application	Delay	Data rate	Information loss
Conversational (e.g. audio call)	$< 0.4s$ (end-to-end delay)	4-25 kbit/s	$< 3\%$ (frame erasure rate)
Streaming (e.g. Movie clips)	$< 10s$ (start-up delay)	20-384 kbit/s	$< 2\%$ (packet loss ratio)
Interactive (e.g. WWW browsing)	$< 4s$ (one-way delay)	4-13 kbit/s	$\ll 1$ (frame erasure rate)

4.1.2 Subjective weights calculation

We derive the effective weights of use case applications from their performance requirements of table 4.1. We start by normalizing the table¹. This step is essential to remove dimensional units and thus be able to compare each criterion's relative importance for a defined application. The normalized value x'_{ij} of application i regarding its performance criterion j such that $1 \leq i \leq N, 1 \leq j \leq M$ is obtained in eq. 4.1. N represents the number of use case application profiles and M the number of performance criteria.

$$x'_{ij} = \frac{x''_{ij}}{\sum_{k=1}^N x''_{kj}} \quad (4.1)$$

In eq. 4.1 $x''_{ij} = x_{ij}$, if j^{th} criterion is "larger-the-better", and $x''_{ij} = \frac{1}{x_{ij}}$, if j^{th} criterion is the "smaller-the-better". x_{ij} are the non-normalized values in table 4.1. "smaller-the-better" is associated with a criterion that we aim to minimize, and "larger-the-better" is associated with a criterion that we aim to maximize. Thus, *Delay* and *Information loss* are considered as "smaller-the-better", while the *Data rate* is considered as "larger-the-better".

¹Note that this normalization is different than the one in Section 3.1.6 which is applied on the actual decision data statistics. The normalization here is done only once to drive the criteria weights to take into account in decision making.

For example, the normalized value of performance expectation for Conversation application regarding the delay e.g., $i = 0$ and $j = 0$ in table 4.1 is:

$$x'_{00} = \frac{1/0.4}{1/0.4 + 1/10 + 1/4} = 0.877192982 \approx 0.88$$

Also, the normalized value of performance expectation for Conversation application regarding the data rate, considering the upper bound of the interval is:

$$x'_{0,1} = \frac{25}{25 + 385 + 13} = 0.059101655 \approx 0.06$$

Using the same procedure of applying eq. 4.1 on Table 4.1 we obtain Table 4.2 which gives the normalized values for each criterion and each use case application.

TABLE 4.2 Normalized end-user performance expectations of some multimedia applications.

Application	Delay	Data rate	Information loss
Conversational (e.g. audio call)	0.88	0,06	0.00033
Streaming (e.g. Movie clips)	0.035	0.91	0.0005
Interactive (e.g. WWW browsing)	0.088	0,033	0.99

Construction of pairwise comparison matrices

The construction of the pairwise comparison matrix for each application profile i is done by applying eq. 4.2 on Table 4.2. Where $1 \leq u \leq M, 1 \leq v \leq M$ and $v > u$, represent the relative importance degree of criterion u compared to criterion v .

$$a_{uv} = \frac{x'_{iu}}{x'_{iv}} \quad (4.2)$$

For example, for Conversational application (e.g., $i = 0$), the relative importance degree of its delay criterion (e.g., $u = 0$) regarding its data rate criterion (e.g., $v = 1$) is:

$$a_{01} = \frac{x'_{00}}{x'_{01}} = \frac{0.88}{0.06} = 14.84210526 \approx 14.84$$

Thus, for Conversational application, the relative importance degree of the data

rate criterion regarding the delay criterion is the inverse of a_{01} : $a_{10} = 1/a_{01} = 1/14.86 \approx 0.07$. Using the same procedure of apply applying eq. 4.2 on Table 4.2, the pairwise comparison matrix of Conversational application is as follows:

$$A_{Conv} = \begin{array}{c|ccc} & \text{Delay} & \text{Data rate} & \text{Information loss} \\ \hline \text{Delay} & 1 & 14,84 & 2633,77 \\ \text{Data rate} & 0,07 & 1 & 177,45 \\ \text{Information loss} & 0,0004 & 0,006 & 1 \end{array}$$

Table 4.3 gives the pairwise comparison matrices for all three use case applications.

TABLE 4.3 Pairwise comparison matrices from end-user performance expectations.

Application	Pairwise comparison matrix		
Conversational	1	14,84	2633,77
	0,07	1	177,45
	0,0004	0,006	1
Streaming	1	0,039	70,23
	25,87	1	1817,12
	0,014	0,0006	1
Interactive	1	2,65	0,088
	0,38	1	0,033
	11,4	30,19	1

Driving effective weights

We use Weighted Least Squares (WLS) method as an estimation method to drive effective weights from the pairwise comparison matrices. Using the WLS method, the optimization problem in eq. 3.11 is solved analytically in [8] to estimate effective weights W from a pairwise comparison matrix A as follows:

$$W = \frac{B^{-1} \cdot E}{E^T \cdot B^{-1} \cdot E}, \quad B = \text{diag}(A \cdot A^T) - A - A^T + M \cdot I \quad (4.3)$$

In eq. 4.3, I is $M \times M$ size identity matrix, E is $M \times 1$ size matrix with each element equal to 1, diag nulls out all the elements of the $M \times M$ size input matrix except the elements in diagonal. Thus, for example, the application of eq. 4.3 to pairwise comparison matrix of Conversation application to estimate effective

weights W_{Conv} is as follows.

$$A \cdot A^T = \begin{bmatrix} 1 & 14,84 & 2633,77 \\ 0,07 & 1 & 177,45 \\ 0,0004 & 0,006 & 1 \end{bmatrix} \cdot \begin{bmatrix} 1 & 0.067 & 0.0004 \\ 14.84 & 1 & 0.006 \\ 2633.77 & 177.45 & 1 \end{bmatrix} = \begin{bmatrix} 1.00454 & 14.9095 & 2645.73 \\ 14.9095 & 221.288 & 39268.2 \\ 2645.73 & 39268.2 & 6.96825e^{06} \end{bmatrix}$$

$$diag(A \cdot A^T) = \begin{bmatrix} 1.00454 & 0 & 0 \\ 0 & 221.288 & 0 \\ 0 & 0 & 6.96825e^{06} \end{bmatrix}$$

$$M \cdot I = 3 \cdot \begin{bmatrix} 1 & 0 & 0 \\ 0 & 1 & 0 \\ 0 & 0 & 1 \end{bmatrix} = \begin{bmatrix} 3 & 0 & 0 \\ 0 & 3 & 0 \\ 0 & 0 & 3 \end{bmatrix}$$

$$diag(A \cdot A^T) - A - A^T + M \cdot I =$$

$$\begin{bmatrix} 2.00454 & -14.9095 & -2633.77 \\ -14.9095 & 222.288 & -177.458 \\ -2633.77 & -177.458 & 6.96825e^{06} \end{bmatrix}$$

$$= B$$

$$B^{-1} = \begin{bmatrix} -6.49667e^{15} & -4.37719e^{14} & -2.46668e^{12} \\ -4.37719e^{14} & -2.94917e^{13} & -1.66195e^{11} \\ -2.46668e^{12} & -1.66195e^{11} & -9.36558e^{08} \end{bmatrix}$$

$$B^{-1} \cdot E = \begin{bmatrix} -6.49667e^{15} & -4.37719e^{14} & -2.46668e^{12} \\ -4.37719e^{14} & -2.94917e^{13} & -1.66195e^{11} \\ -2.46668e^{12} & -1.66195e^{11} & -9.36558e^{08} \end{bmatrix} \cdot \begin{bmatrix} 1 \\ 1 \\ 1 \end{bmatrix} = \begin{bmatrix} -6.93686e^{15} \\ -4.67377e^{14} \\ -2.63381e^{12} \end{bmatrix}$$

$$E^T \cdot B^{-1} \cdot E = \begin{bmatrix} 1 & 1 & 1 \end{bmatrix} \cdot \begin{bmatrix} -6.93686e^{15} \\ -4.67377e^{14} \\ -2.63381e^{12} \end{bmatrix} = -7.40687e^{15}$$

$$\frac{B^{-1} \cdot E}{E^T \cdot B^{-1} \cdot E} = \begin{bmatrix} -6.93686e^{15} / -7.40687e^{15} \\ -4.67377e^{14} / -7.40687e^{15} \\ -2.63381e^{12} / -7.40687e^{15} \end{bmatrix} = \begin{bmatrix} 0.936544 \\ 0.0631005 \\ 0.00035559 \end{bmatrix} = W_{Conv}$$

Using the same procedure of applying eq. 4.3 for each application's pairwise comparison matrix, Table 4.4 gives the estimated weight vectors for all the three use case applications.

In what follows, we present simulation scenarios and results for the evaluation of DURATS where one application is deployed per node (in Section 4.1.3), and where the three applications coexist on each node (in Section 4.1.4).

TABLE 4.4 Weight vector of use case application derived from end-user performance expectations.

Application	Weight vector
Conversational	$[0.94 \ 0.06 \ 0.0004]^T$
Streaming	$[0.037 \ 0.96 \ 0.0005]^T$
Interactive	$[0.078 \ 0.029 \ 0.892]^T$

4.1.3 DURATS with a single application

Simulation scenario and parameters

Our goal is to assess DURATS' impact on network performances when only one of the before-mentioned use cases applications is deployed per node. To proceed, we have considered two groups of nodes. The first group is called "Decision-makers." It is composed of 10 peer nodes wherein each peer; there is a source node and a destination node. The traffic source nodes use DURATS to choose the RAT to transmit, namely "interface 0" and "interface 1", to send unicast traffic to the traffic destination nodes. The second group of nodes, called "Dummy traffic generators" is composed of nodes that run a dummy service. The dummy service traffic acts as disturbance/noise traffic for "Decision-makers" on their "interface 0". Figure 4.1 illustrates the simulation scenario. We varied the disturbance traffic from 20% to 100% of the channel capacity for each scenario.

DURATS is assessed in a scenario where "interface 0" uses IEEE 802.11, and "interface 1" uses LTE-D2D unicast. DURATS is compared to a baseline method for each use case application. The baseline method selects the interface with the last known best value of the criterion, which has the highest weight for the application. For example, for Conversational applications, the baseline method selects the interface with the lowest delay.

The reception capacity of nodes is bounded by their technology's data rates (6 Mbps for IEEE 802.11 and 6.7 Mbps for LTE-D2D unicast). Two traffic load densities are considered: Low and High. In low density, source nodes generate application data traffic which corresponds to 20% of the maximum reception capacity offered by the interface. Whereas, with high traffic load density, source nodes generate application data traffic corresponding to 70% of the maximum reception capacity. In addition to the data traffic, periodic control traffic is deployed

on each interface of source nodes. The control traffic running in the background provides more accurate channel estimations and is 5% of the maximum capacity of the interface. The statistic samples size γ impacting the maximum Data Life Time (δ_{max}) is fixed to 10, while the minimum Data Life Time (δ_{min}) is align with the duration equivalent to generation of one control traffic packet.

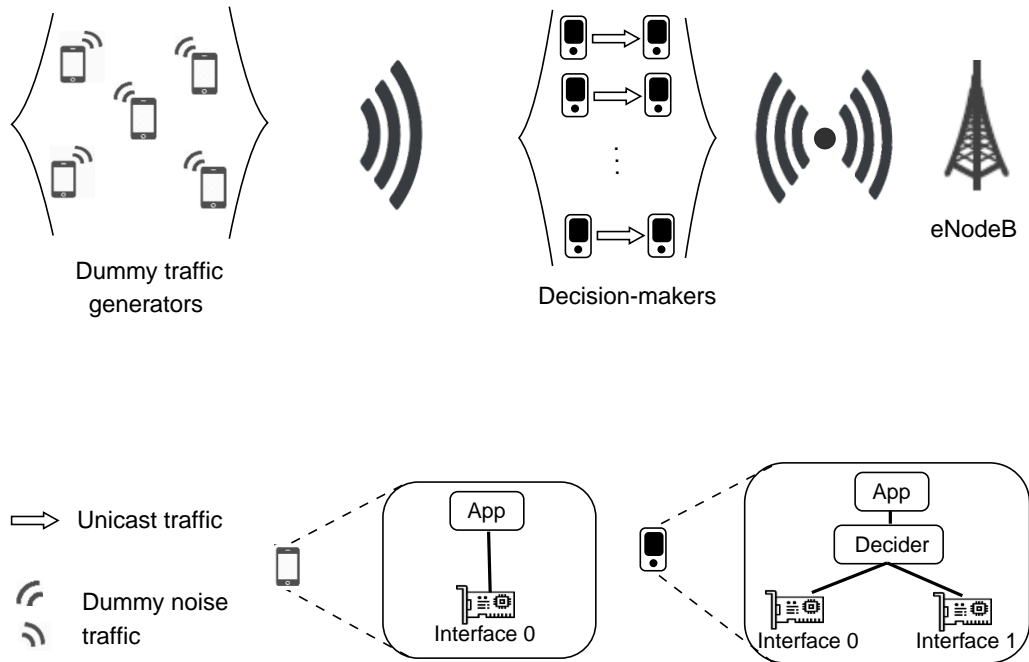

FIGURE 4.1 Simulation scenario composed of two node groups: decision makers and dummy traffic generators.

Simulation results

Results presented in this section are averages of 60 repetitions for scenarios of 60 seconds. Each repetition is composed of $2 * 6 * 5$ scenario runs. 2 is for the low and high density scenarios. 6 corresponds to the combination of run of DURATS and Baseline with one of the three applications. 5 corresponds to the different rates of disturbance traffic (20%, 40%, 60%, 80% and 100%).

For each simulation run where the seed of random number generators is changed, we measure, as performance metrics, End-2-End (E2E) packet delay, effective average total throughput and packet delivery rate, of all the 10 node pairs. We first compare for each application performance's associated to its most weighted criterion. This means, for each couple of DURATS and Baseline runs, we compare

E2E packet delay performance for the Conversational, effective throughput performance for the Streaming application, and packet delivery rate performance for the Interactive application.

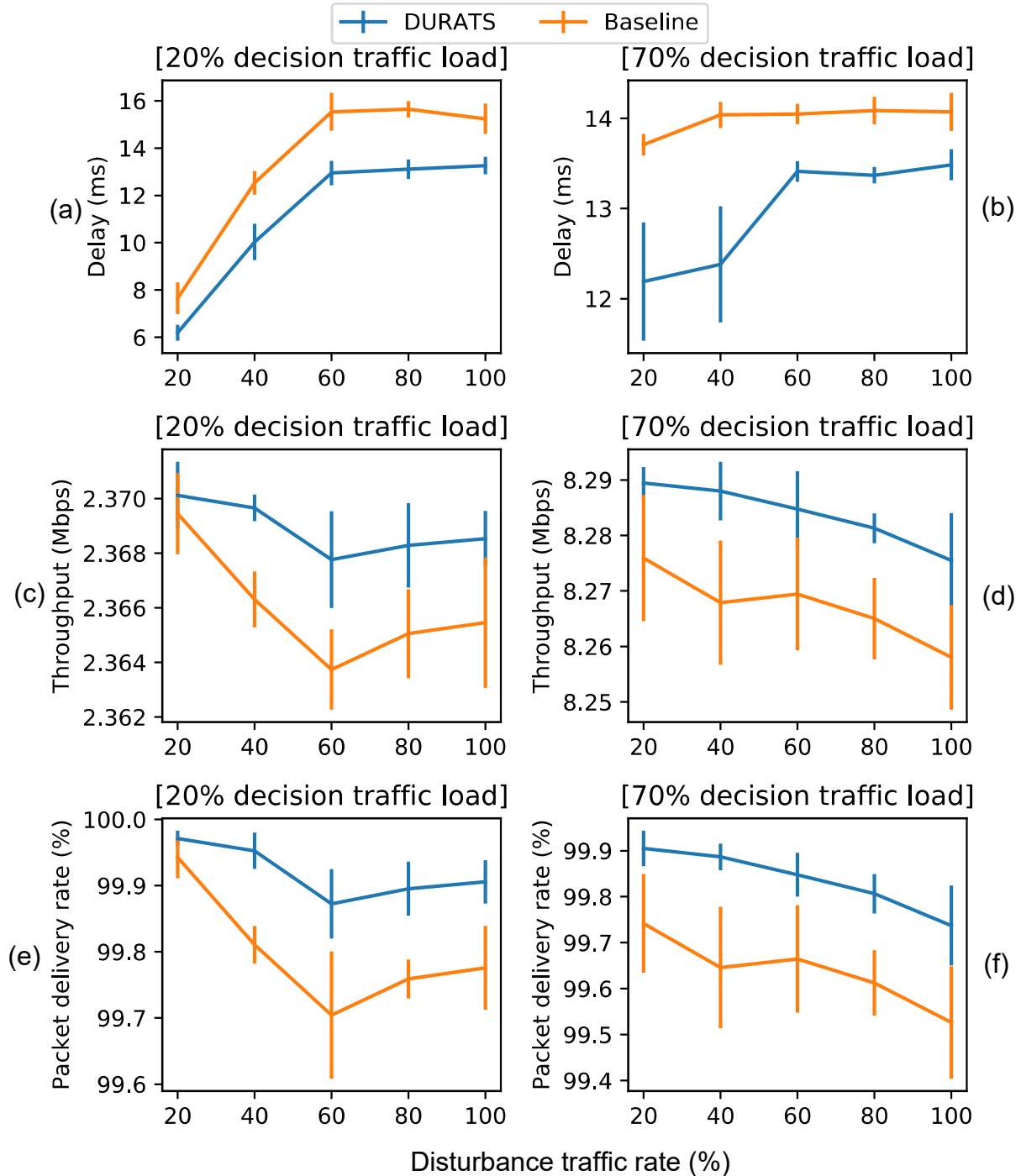

FIGURE 4.2 Delay based decision results for Conversational application.

Figures 4.2-(a) and 4.2-(b) show that DURATS outperforms the baseline algo-

rithm for delay-based decision both in low and high load density scenarios on the delay metric which is the most weighted criteria for the application. Thus, the baseline method here selects the interface with the last known lowest delay metric. We note that in Figures 4.2-(c), 4.2-(d), 4.2-(e) and 4.2-(f), throughput and packet delivery rate performances are almost the same. Indeed, as traffic increases, there would be more fluctuation of the network metrics, hence the importance of the decision based on the moving average compared to the decision based on the last known values of the metrics. This explains that the performance gap between DURATS and the baseline mechanism becomes larger when disturbance traffic increases in low density scenario of Figure 4.2-(a). Then, in high density scenario of Figure 4.2-(b), the performance of DURATS tend to be close to one of the baseline mechanism when disturbance traffic increase. This shows on the other hand DURATS adaptability of the Data Life Time interval to smaller values as a result of fluctuating decision metrics with increasing traffic load.

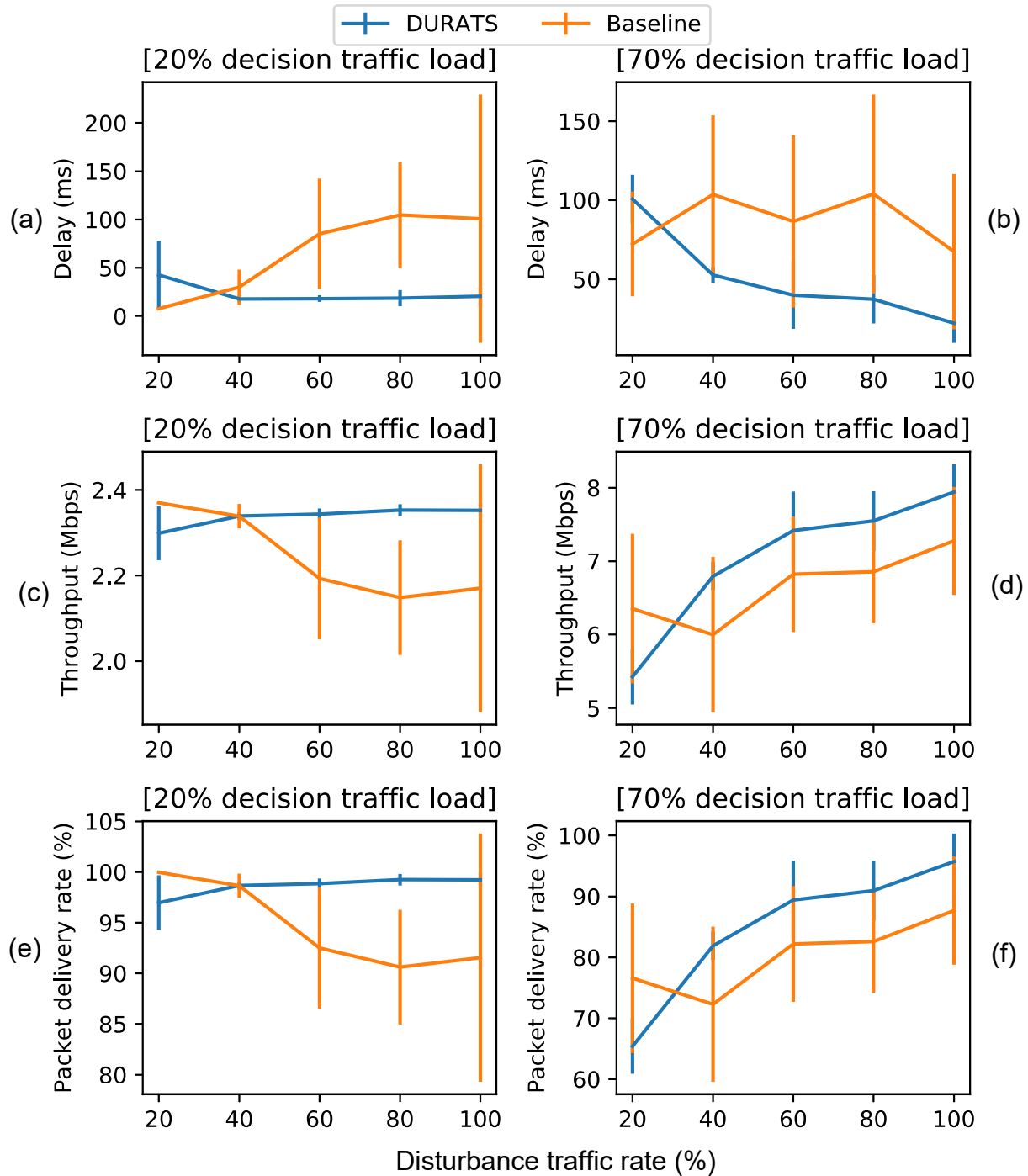

FIGURE 4.3 Throughput based decision results for Streaming application.

Figures 4.3-(c) and 4.3-(d) show that DURATS outperforms the baseline algorithm for throughput-based decisions both in low and high load density scenarios on throughput metric which is the most weighted criteria of the application. Thus, the baseline method here selects the interface with the last known highest

throughput. We note that the performances are slightly lower under a low disturbance traffic rate. We also note that the performance of both DURATS and the baseline increases progressively as the interference increases. This is because the nodes choose Wi-Fi more often, which offers a slightly similar throughput to that of LTE-D2D at low interference. Then as the interference increases on their Wi-Fi interface, they gradually select LTE-D2D more often. In contrast to Figures 4.2-(a) and 4.2-(b) (or Figures 4.4-(a) and 4.4-(b)), we note less clear separation of delay performances between DURATS and the baseline in Figures 4.3-(a) and 4.3-(b). This can be explained by the fact that the interface which offers the best throughput at a given time is not necessarily the one which offers also the best delay performance. This is typically the case where the LTE-D2D offers better throughput than Wi-Fi by aggregating and scheduling the sending of multiple packets at once, but by doing so it increases inter-packet delay also.

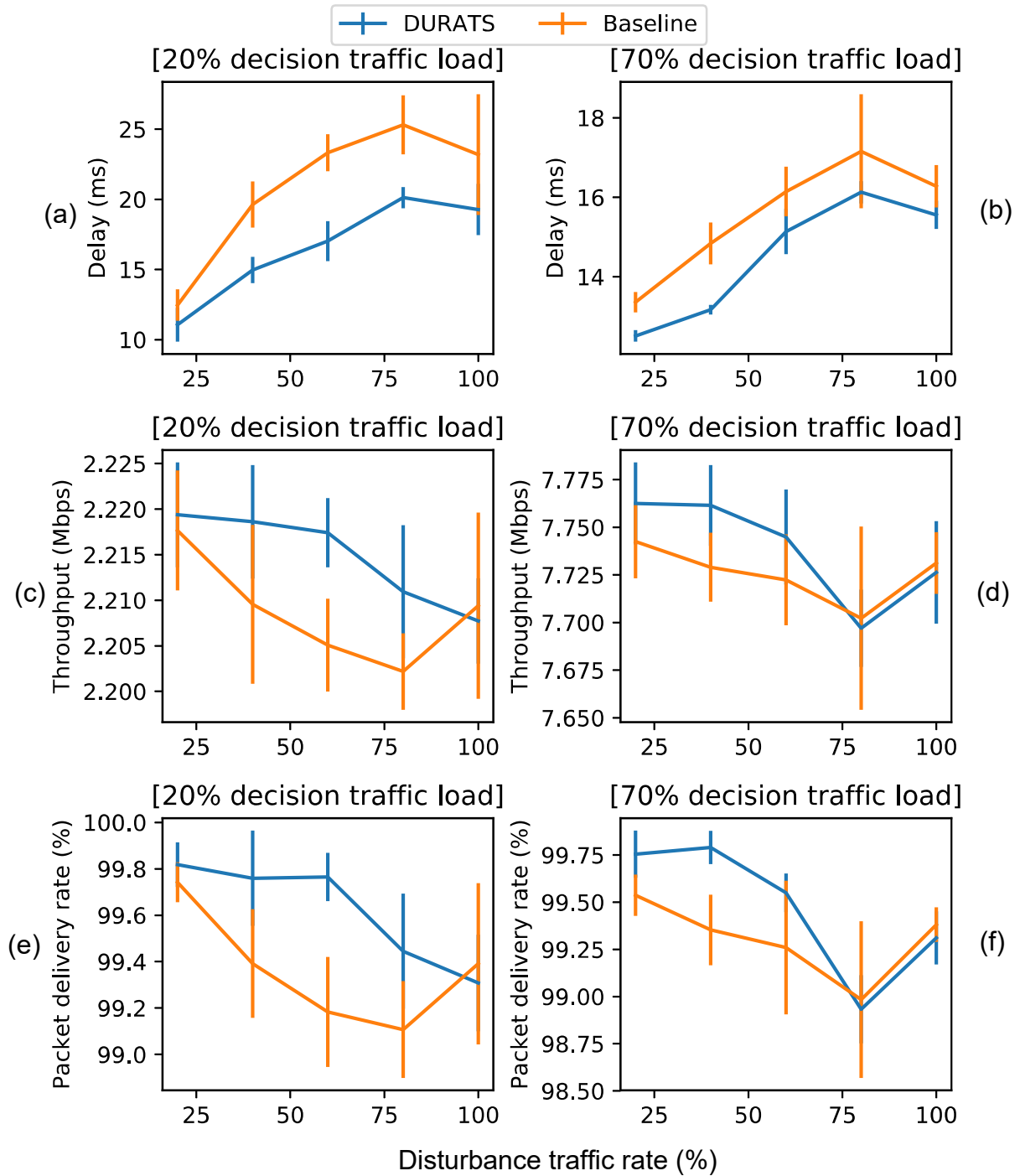

FIGURE 4.4 DDR based decision results for Interactive application.

Figures 4.4-(e) and 4.4-(f) show DURATS and the baseline algorithm have almost the same performances on packet delivery rate which is the most weighted criteria associated to the application. Thus, the baseline method here selects the interface with the last known highest DDR metric. DURATS and the baseline

having the same performance can be explained by the fact that DURATS is designed to adapt Data Life Time, therefore, its behavior can be close the baseline by reducing the Data Life Time interval. We note that in contrast to the delay performances in Figures 4.4-(a) and 4.4-(b), the pattern in Figures 4.4-(e) and 4.4-(f) of packet delivery ratio performances are almost the same as for the throughput. This can be explained by the fact that the throughput metric is more correlated to the DDR metric than with the delay metric.

4.1.4 DURATS with multiple applications

Simulation scenario and parameters

Our goal is to assess the impact of DURATS on network performances considering the before-mentioned use case applications when they all coexist on each node. To proceed, we co-locate 12 pair of nodes divided into four groups (e.g., three pair of nodes per group). Each pair of nodes is formed by a source node and a destination node. Source nodes choose among two interfaces, namely "interface 0" and "interface 1", to send unicast traffic to the traffic destination node for three types of applications deployed, namely, Conversational, Streaming, and Interactive. Figure 4.5 illustrates the simulation scenario. The interface decision mechanism is specific for each group.

- The first group of nodes uses *DURATS* to choose the transmission interface.
- The second group of nodes uses a decision mechanism named "DURATS-Simple", which selects the interface with the last known best value of criterion that has the highest weight for the application. For example, for a Conversational application, the method chooses the interface having the lowest delay for the last collected transmission event.
- The third group uses a decision mechanism named "*RandomDecision*", where the selection is made following Bernoulli's law with probability $p = 0.5$ for choosing each interface. Thus, the decision mechanism of each of the three applications of this node group is the same and their performances are expected to be the same regarding the different metrics.
- The fourth group uses a decision mechanism named "*FixedDecision*". "Fixed-

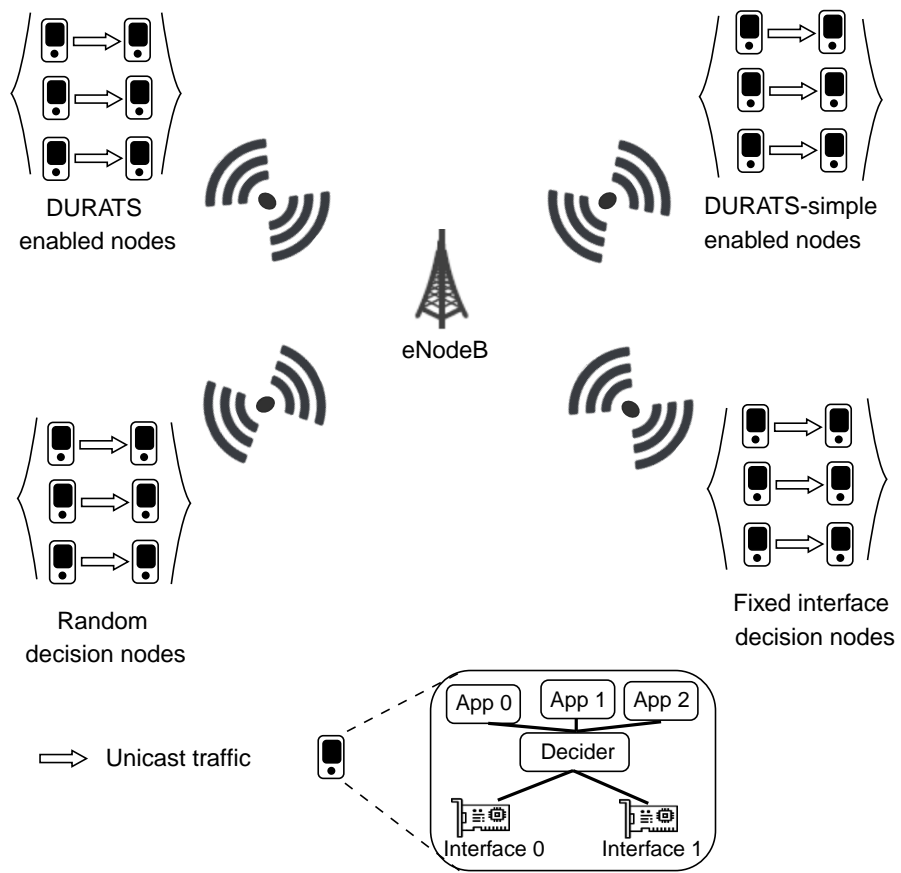

FIGURE 4.5 Simulation scenario composed of four node groups each with different interface selection mechanism.

"Decision" consists of systematically transmitting via "interface 0" for Conversational application traffic (having more stringent in terms of delay), and systematically transmitting via the "interface 1" Streaming and Interactive application's traffic (having more stringent in terms of throughput and DDR respectively).

The nodes are configured to use IEEE 802.11 technology with their "interface 0," and LTE-D2D unicast with their "interface 1". Thus, the rationale of this "FixedDecision" is that, as the traffic increases, IEEE 802.11 offers better delay performance than LTE-D2D unicast but with worse throughput and DDR also.

Performances of each group are then assessed considering multiple traffic loads varied from 20% to 100% of the maximum reception capacity offered by the node interfaces. Data rates of the technologies associated with the interfaces bound the reception capacity. Average bitrates of the technologies are considered; 24 Mbps for the IEEE 802.11 model and Channel Quality Indicator (CQI) 8 (out of the fifteen CQI levels) for the LTE-D2D unicast model. The traffic generated is equally spread over the 12 pairs of nodes for each load level. And this traffic, in turn, is distributed equally among the three applications coexisting on the node. In addition to the data traffic, a periodic control traffic is deployed on each interface of source nodes. The control traffic running in the background is to probe the interfaces periodically to provide more accurate channel estimations and is fixed to 1% of the maximum capacity of each interface. The statistic samples size γ impacting the maximum Data Life Time (δ_{max}) is fixed to 10, while the minimum Data Life Time (δ_{min}) is align with the duration equivalent to generation of one control traffic packet.

Simulation results

Figures 4.6, 4.7 and 4.8 show the relative performance of the baseline methods "RandomDecision" and "FixedDecision" group of nodes vs. the performance of DURATS and DURATS-simple for delay-based decision, throughput-based decision and DDR-based decision, respectively. As for performance metrics, we measure for each node group the average of End-to-End (E2E) packet delay, effective

throughput, and packet delivery rate for all the applications. We then first compare each node group application's performance associated to its most weighted criterion. This means, for each node group, we compare End-to-End (E2E) packet delay performance for the Conversational, effective throughput performance for the Streaming application, and packet delivery rate performance for the Interactive application. Results are averages of 100 repetitions for 30 seconds scenario duration per repetition. Each repetition is composed of five runs which corresponds to run of Figure 4.5 scenario with the five data traffic load rates (20%, 40%, 60%, 80% and 100%). In each simulation run, the seed of random number generators such in Wi-Fi's Distributed Coordination Function (DCF) or LTE-D2D's Random Access Channel (RACH) is changed.

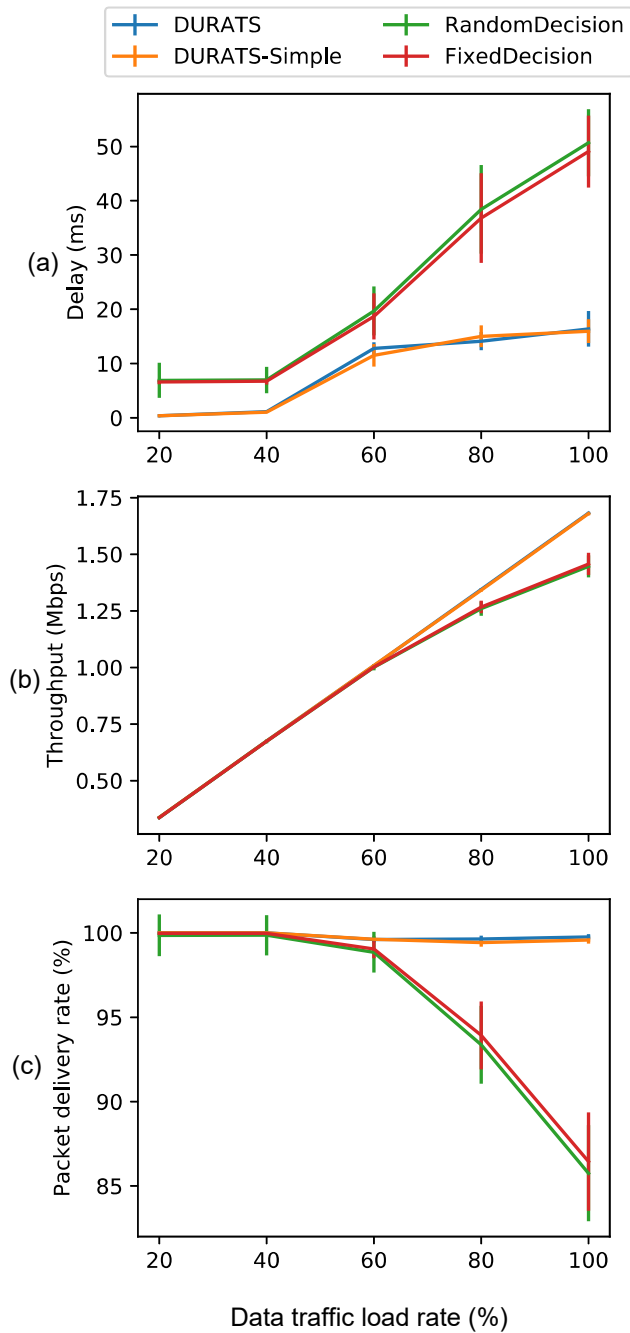

FIGURE 4.6 DURATS and DURATS-simple delay-based decision results for Conversational application vs. random and fixed decision results.

Figure 4.6-(a) shows that DURATS related delay-based decision mechanisms outperform baseline mechanisms regarding the delay performance. DURATS related delay-based decision mechanisms outperform baseline mechanisms also regarding the throughput (in Figure 4.6-(b)) and regarding the DDR (in Figure 4.6-(c)). Also, the performance gap increases when the data traffic increases. We note

that the performances of DURATS and DURATS-Simple are almost the same. This can be explained by the fact that the DURATS is designed to adapt Data Life Time, therefore, its behavior can be close to the DURATS-simple when the decision metrics fluctuate and the Data Life Time is reduced. We also note that the performance of "FixedDecision" outperforms the "RandomDecision" as the load increases. This is because "FixedDecision" sends more traffic than the random mechanism on the interface that usually offers the best performance according to the application's needs.

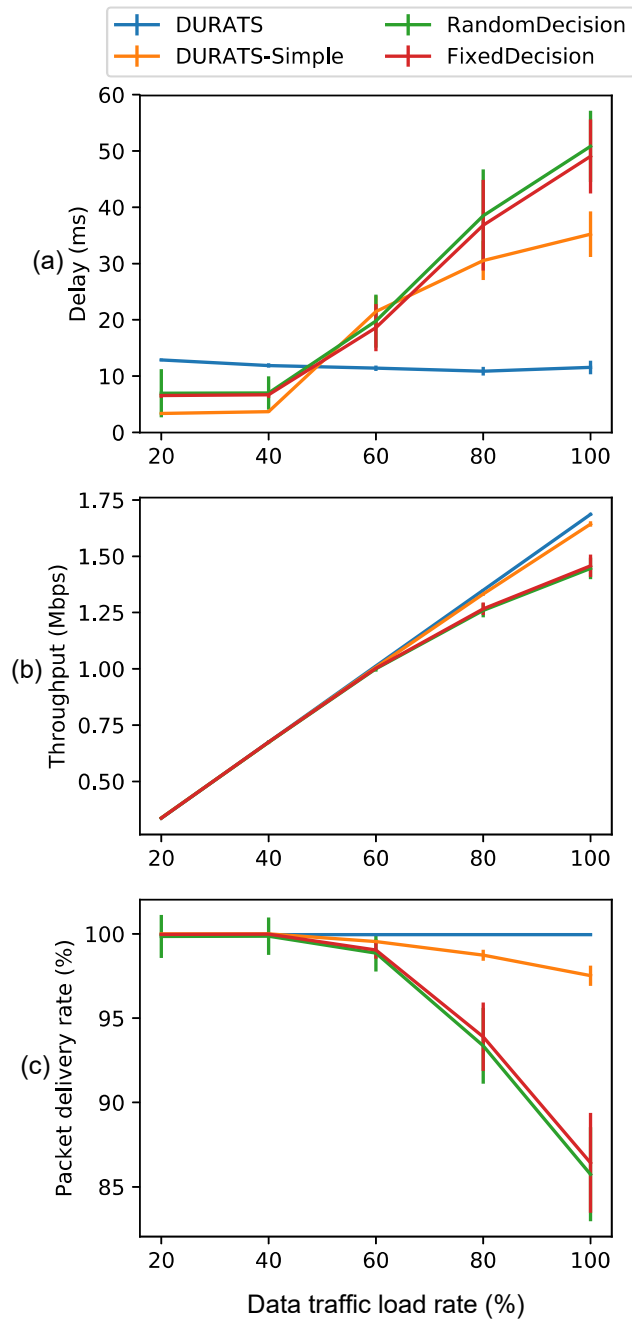

FIGURE 4.7 DURATS and DURATS-simple throughput based decision results for Streaming application vs. random and fixed decision results.

Figure 4.7-(b) shows that DURATS related throughput-based decision mechanisms outperform baseline mechanisms regarding the throughput performance. We note that the performances of DURATS decision mechanisms are not always better than the baseline mechanisms regarding the delay in Figure 4.7-(a). This can be explained by the fact that the interface offering better throughput (which

is the criterion having the more significant weight in DURATS and DURATS-simple decision) does not necessarily provide a better delay. This is typically the case where the LTE-D2D unicast offers better throughput than the IEEE 802.11 by aggregating and scheduling the sending of multiple packets at once, but by doing so it increases inter-packet delay. We also note that the gap between DURATS, DURATS-simple, and the baseline mechanisms increases when traffic increases as for results of Figure 4.6-(a) and Figure 4.8-(c). This can be explained by the fact that, as traffic increases, network metrics will fluctuate more. Hence, the importance of the decision based on average metrics' statistics of DURATS, compared to the decision based on the last known values of the metrics of DURATS-simple.

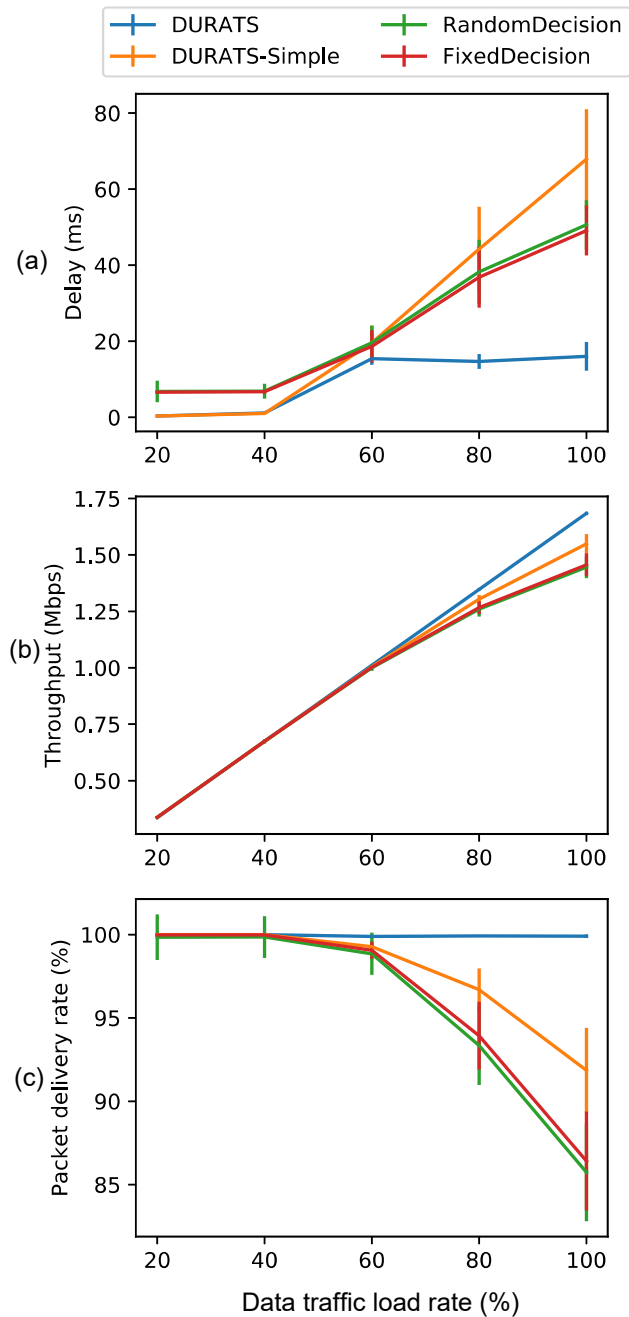

FIGURE 4.8 DURATS and DURATS-simple *DDR* based decision results for Interactive application vs. random and fixed decision results.

Figure 4.8-(c) shows that the performance of DURATS related *DDR*-based decision mechanisms outperform baseline mechanisms regarding the *DDR* performance. As results in Figure 4.7-(a), we note that the performances of DURATS decision mechanisms are not always better than the baseline mechanisms regarding the delay in Figure 4.8-(a). We also note that the gap between DURATS,

DURATS-simple, and the baseline mechanisms increases when traffic increases as for results of Figure 4.6-(a) and Figure 4.7-(b). In Figures 4.8-(b) and 4.8-(c), we note a similar pattern of results as in Figures 4.7-(b) and 4.7-(c) respectively. This can be explained by the correlation of the throughput and DDR metrics.

4.2 IEEE 802.15.4 MAC aware of IEEE 802.11

As the second component of this thesis contribution, this section presents evaluation and results of our proposals for enhancing IEEE 802.15.4 and IEEE 802.11 coexistence which benefits from a virtual Clear Channel Assessment (CCA) given by the Wi-Fi interface present on the same device. In what follows, we will use the terms "Wireless Local Area Network (WLAN)" and "Wi-Fi" interchangeably to refer to IEEE 802.11. We will also use the term "Wireless Personal Area Network (WPAN)" to refer to IEEE 802.15.4.

4.2.1 Simulation model and parameters

We used INET v4.2 as a simulation platform to evaluate the two proposed techniques for enhancing the coexistence of IEEE 802.15.4 and IEEE 802.11. INET v4.2 support cross-technology interference [15]. We developed two patches for the IEEE 802.15.4 model in this simulation framework [2]. The first patch consists of making the Clear Channel Assessment (CCA) duration compliant with the standard specifications. Indeed, the implementation in the INET v4.2 code consists of making an instantaneous CCA at the end of the CCA duration. We modified this part of the code in order to make the node do a CCA for the whole duration of 8 symbols as specified by the standard. The second patch makes the transmission attempt procedure compliant with the standard specifications. Indeed, the INET v4.2 code does not drop a frame when it reaches the maximum transmission attempt retry number. Instead, a node keeps sending the same frame until it is finally sent. We modified the code to manage a transmission attempt retry number as specified by the standard and drop the frame once this number is reached.

A packet is received on the radio interface when two conditions are met. First, physical properties (such as modulation techniques) should match between trans-

mitting and receiving interfaces. Second, the relative Signal-to-Noise plus Interference Ratio (SNIR) of the packet at the receiving interface should be above a predefined threshold. We used 4 dB and -8 dB for WLAN and WPAN respectively, these are the default settings for these technologies [5, 16].

In the simulation scenario, we co-located IEEE 802.11 (WLAN) and IEEE 802.15.4 (WPAN) networks operating in the 2.4 GHz ISM band. Figure 4.9 illustrates the simulation scenario. The channels of the two technologies are configured to be fully overlapping. The signal spectrum of WLAN radios uses IEEE 802.11 Orthogonal Frequency Division Multiplexing (OFDM) spectral mask with 20MHz wide channels, and WPAN radios transmit narrow-band signals based on CC2420 Zigbee transmitters.

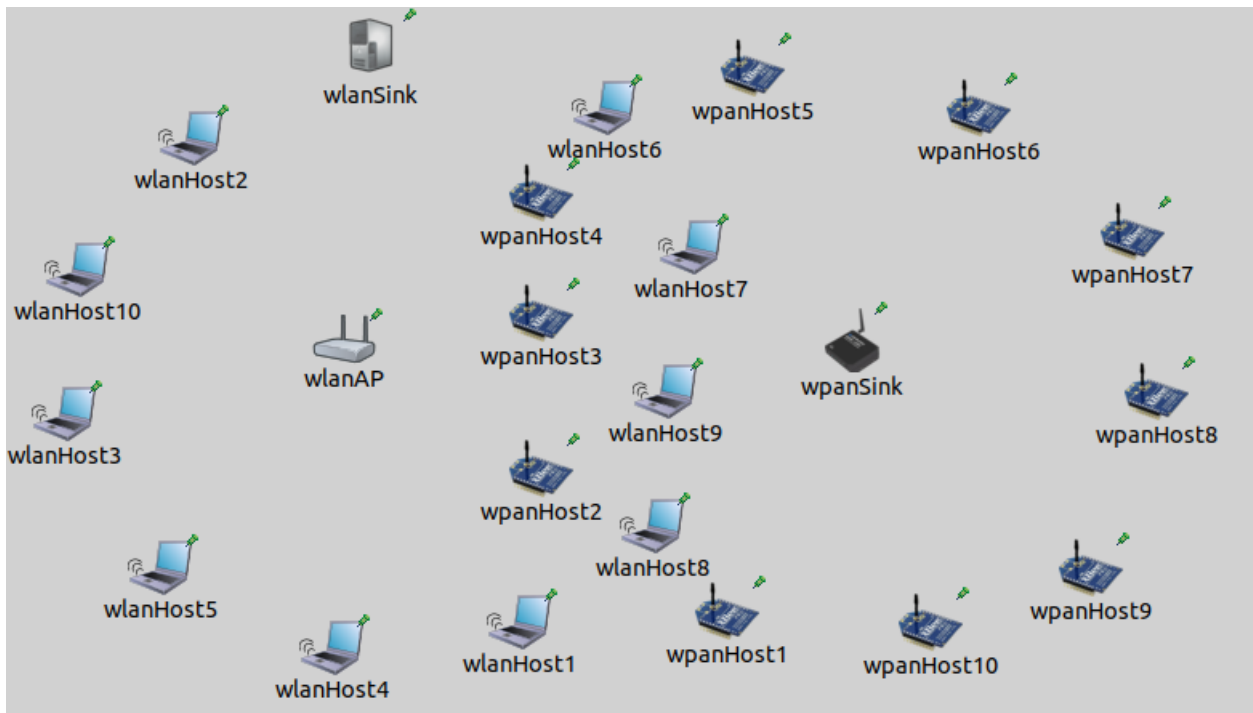

FIGURE 4.9 WLAN and WPAN co-located with ten traffic source nodes and one traffic destination node in each network.

Ten nodes in each network send traffic to a Sink node. Traffic from nodes in the WLAN passes through an Access Point (AP). The nodes of the WPAN network are equipped with Wi-Fi interfaces which allow them to perform the virtual Clear Channel Assessment (CCA) on its Network Allocation Vector (NAV). The relative nodes' positions may change between repetitions, and we ensured that all the

nodes were in the range of one another in each scenario repetition.

All transmissions of WLAN network use the RTS/CTS mechanism. The traffic of each transmitter node in the WPAN is the same and is fixed at the rate of 20 packets per second. This rate maximizes the throughput on their channel as shown in [3, 62]. The amount of traffic generated by every WLAN node is the same and is proportional to the offered load depending on the data rate. This means if x Mbps is offered in WLAN, each transmitter node generates $x/10$ Mbps of traffic.

UDP is used as a transport protocol to control the traffic injection rate better. We considered the maximum payload size for each technology (1500 bytes for 802.11 and 88 for 802.15.4). In WLAN, this packet size could justify the need for this packet to be protected by the RTS/CTS mechanism. Additional simulation parameters are listed in table 5.1 in the appendix.

4.2.2 Numerical results

Results in this section are an average of ten repetitions for 120 seconds of scenario duration per repetition. Results with the labels prefixed by "B-CSMA" on the figures refer to the basic (standard) CSMA/CA mechanism. Results with the label prefixed by "E-CSMA-1" and "E-CSMA-2" refer respectively to our extended mechanisms 1 (section 3.2.1) and 2 (section 3.2.2) of the backoff procedure using both virtual CCA given by the WLAN interface. We considered a minimum data rate of 6 Mbps and a maximum data rate of 54 Mbps. We aim to study the impact at the CSMA/CA mechanism level for 20 MHz channels in Wi-Fi networks. These data rates and channel width are supported by IEEE 802.11b/g/n/ax amendments (802.11b only supports 6 Mbps) operating in the 2.4 GHz.

The standard deviations of all average values presented in the graphs are displayed on all figures but not much visible on some of them as they are small. Tables 5.2 and 5.3 in the appendix give the standard deviation (Std Dev) values of the different scenarios.

Packet loss ratio in WPAN

Figure 4.10 shows the packet loss ratio in WPAN as a function of the offered load percentage in WLAN using the minimum and maximum data rates. The

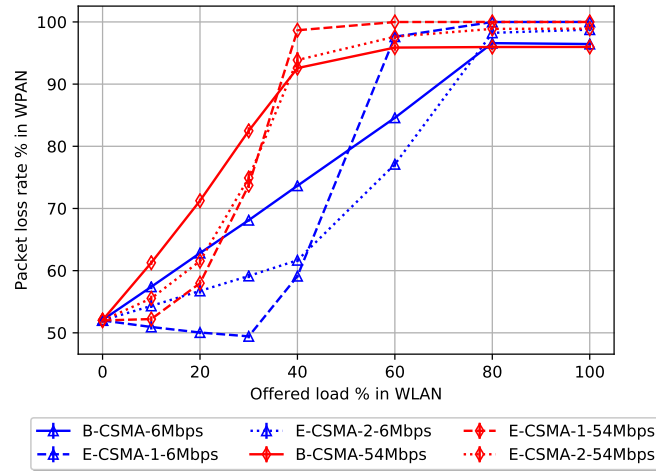

FIGURE 4.10 The average packet loss ratio in the WPAN as a function of offered load in WLAN.

packet loss ratio is the ratio of the sum of traffic generated by the transmitter nodes and the total traffic received at the Sink node. These results first show that the CSMA/CA mechanism of both technologies allows them to coexist up to an offered load threshold. Notice that from an offered load of 40% in WLAN, there is a packet loss rate of more than 90% in the WPAN. Thus, we consider no longer valuable to coexist these two technologies when exceeding this load threshold. Below this threshold, our proposals increase the packet delivery ratio of the basic CSMA/CA mechanism by up to 26% and 13% for backoff mechanisms 1 and 2, respectively, using eq. 4.4 as follows:

$$MaxGain_i = \frac{f(x) - g_i(x)}{f(x)} \times 100 \quad (4.4)$$

where f and g_i are respectively the packet loss rate functions of base mechanism and extended mechanism i . And x is the offered load in WLAN such that $f(x) - g_i(x)$ is maximized. Also note that a higher data rate in WLAN causes more packet loss in WPAN. This will be investigated later.

Throughput in WLAN

Figures 4.12 and 4.11 show the average absolute and relative throughput respectively in WLAN at 40% of offered load using the minimum and maximum data

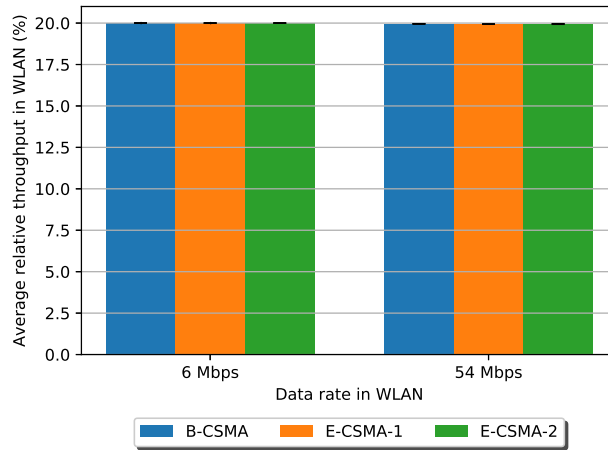

FIGURE 4.11 The average application throughput in WLAN with 40% of offered load relative to data rates used and different CSMA/CA mechanisms in WPAN.

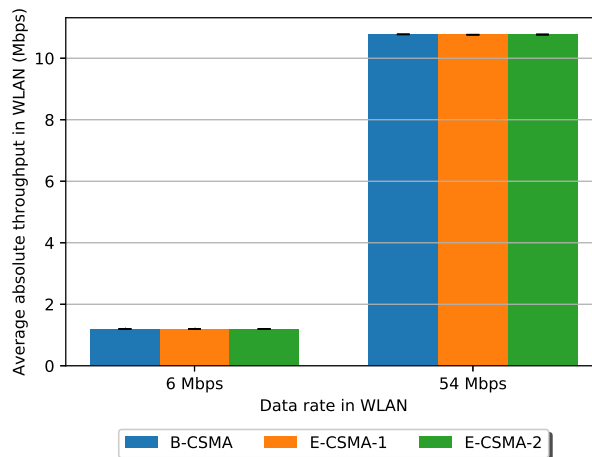

FIGURE 4.12 The average absolute application throughput in WLAN with 40% of offered load using different data rates and CSMA/CA mechanisms in WPAN.

rates. Both Figures show that the CSMA/CA mechanism of WPAN has very little impact on the throughput of WLAN. In Figure 4.12, it can be seen that the throughput is nearly half of the offered load considered. This can be partly explained because with traffic passing through the Access Point, frames from transmitter nodes cross at least twice the channel before reaching the Sink node.

Figure 4.11 shows that the total throughput relative to the receiver capacity, also known as the nominal throughput, for each data rate is almost 20%. Thus, we note that protocol overhead in the WLAN, such as physical layer preamble and header, interframe space, and backoff, has minimal impact on the throughput at this load threshold.

channel occupancy in WLAN

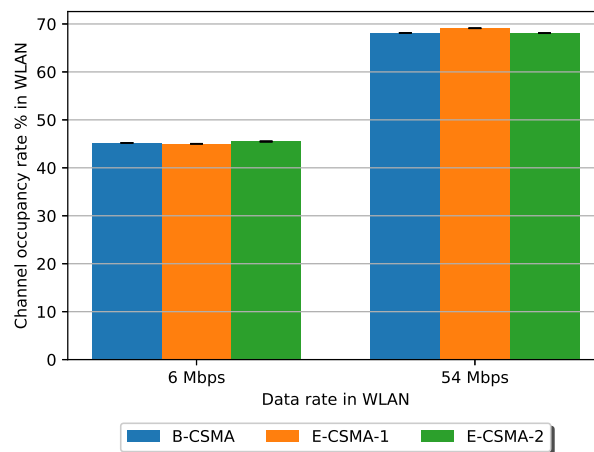

FIGURE 4.13 The average channel occupancy ratio by WLAN with 40% of offered load using different data rates and CSMA/CA mechanisms in WPAN.

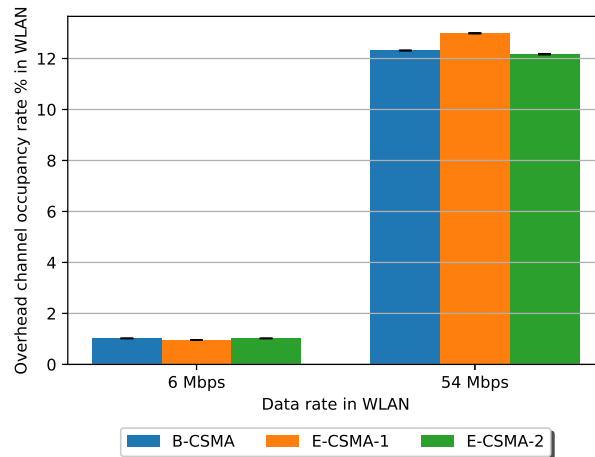

FIGURE 4.14 The average channel occupancy ratio in WLAN due to physical layer overhead (preamble and header) with 40% of offered load using different data rates and CSMA/CA mechanisms in WPAN.

Figure 4.13 shows the channel occupancy of the WLAN with 40% of the offered load for 6 and 54 Mbps data rates. This rate is defined as the ratio between the duration of all transmissions (and retransmissions if any) in WLAN during the simulation and the whole duration of the scenario. Results show that with a data rate of 54 Mbps, the channel is occupied by the WLAN activity at almost a 70% rate. This explains the results of figure 4.10 where a data rate of 54 Mbps causes a higher data loss for WPAN activity. Indeed, with a data rate of 6 Mbps, the WLAN occupies around 45% of channel time. This gives the WPAN more opportunities to send its traffic. This impact can be explained because faster modes in WLAN only transmit the MAC header and content part of frames at higher bitrates. As a result, the overhead (of physical layer preamble and header) on the higher data rates is relatively larger compared to the same offered relative load, and this overhead can be measured in the duration of the transmissions as shown in the results of the figure 4.14. We can also notice a small impact of the type of CSMA/CA used in WPAN on the activity of WLAN

Number of collisions in WPAN

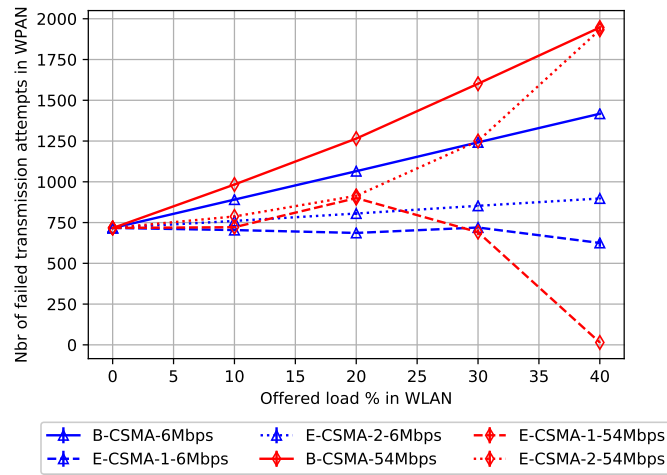

FIGURE 4.15 The average number of failed transmission attempts in WPAN as a function of offered load percentage in WLAN. The results are calculated based on the values of all transmitter nodes.

Figure 4.15 shows the effectiveness of both proposed backoff mechanisms to reduce access collision compared to the standard mechanism. As expected, mechanism 1 reduces access collisions more than mechanism 2. Indeed, the number of failed transmission attempts with mechanism 1 gets close to zero (with 100% loss rate) when the load of the shared channel with WLAN rises above 40%. This is mainly because nodes in WPAN spend their time just doing backoffs and do not attempt to transmit their packets. Whereas, backoff mechanism 2 is not based on the channel activity in WLAN which explains the lower number of reduced collisions compared to mechanism 1. Note that this reduction in access collisions also results in reducing the overall energy footprint of the multi-interface nodes by progressively avoiding longer backoffs followed by CCAs that fail on the WPAN interface.

Access delay in WPAN

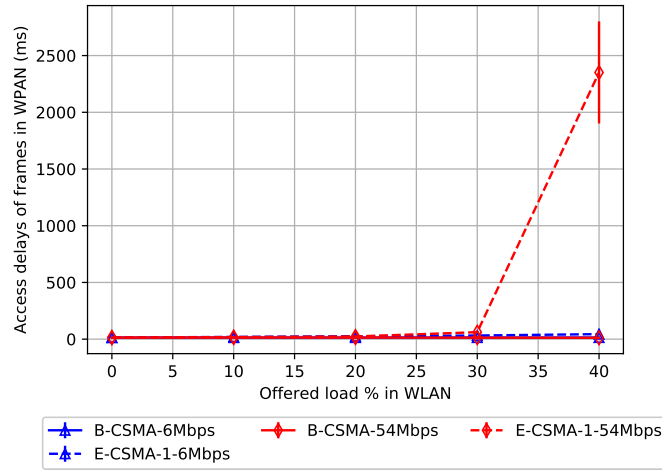

FIGURE 4.16 Average access delay of frames in WPAN as a function of offered load percentage in WLAN. (Mechanism 1 vs base mechanism)

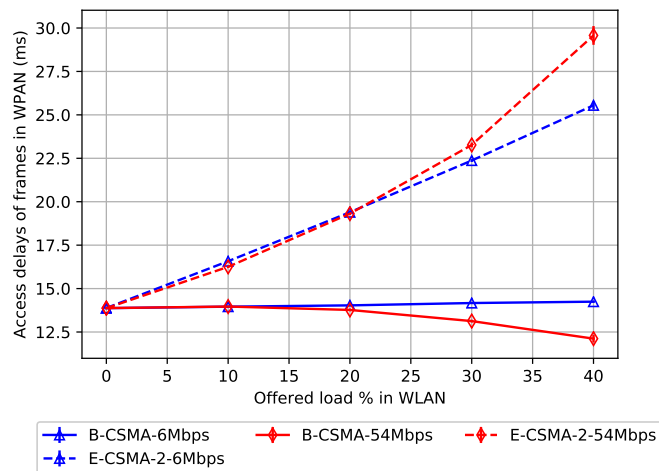

FIGURE 4.17 Average access delay of frames in WPAN as a function of offered load percentage in WLAN. (Mechanism 2 vs base mechanism)

Figures 4.16 and 4.17 show the average access delay of frames of mechanisms 1 and 2, respectively, compared to the standard mechanism. This is the delay from the time a packet reaches head of the MAC queue for transmission till its ACK (if any) is received, including the waiting and transmission time consumed for retransmissions. This result illustrates the average CSMA/CA process cycle duration of the proposed mechanisms that widens as the WLAN load increases.

As a result, there is an increasingly longer delay in transmitting frames over the WPAN channel. We note that backoff mechanism 2 has a lower access delay compared to mechanism 1 when the WLAN load increases. This is explained by the fact that an average backoff time after a virtual CCA failure with mechanism 2 would be relatively fixed compared to that with mechanism 1, which would tend to increase. The significant delay and its standard deviation at the dashed red curve in figure 4.16 when the offered load in WLAN is 40% is because the results are only calculated based on a few frames that still had the opportunity to cross the channel.

CHAPTER 5

CONCLUSIONS AND PERSPECTIVES

This chapter aims to summarize, conclude and give future research directions for this thesis contributions. The stakes highlight the research contributions and recommend future work on the topic.

5.1 Conclusion

This section summarizes the results, the leading pros and cons in the design and evaluation of the two main components of this thesis's contributions.

5.1.1 Access Technology Selection

Access Technology Selection is an essential component in designing heterogeneous networks' coexistence to enable the diversity of future applications, e.g., in the 5G paradigm toward ubiquitous radio access. We designed a RAT selection mechanism, namely DURATS for Distributed User-centric Radio Access Technology Selection framework, to select access technology per application packet basis. The proposed mechanism includes the following.

- Three main decision criteria, namely data delivery ratio, throughput and delay metrics.
- Decision data processing method toward accurate decision data estimation.
- Decision algorithm based on Multi-Criteria Decision-Making.
- An objective method to quantify the QoS constraints of user applications from predefined subjective QoS constraints.

Thus, DURATS is a complete RAT selection framework that selects access technologies per application packet basics, it guarantees that the application is constantly best connected. DURATS assumes that the application's session information is shared between interfaces. This is rarely the case with popular devices like smartphones.

DURATS is evaluated considering three use case applications: Conversational application (with delay as the dominant criterion), Streaming application (with throughput as the dominant criterion) and Interactive application (with Data delivery rate as the dominant criterion). It shows its benefits compared to baseline decision mechanisms such as random or fixed interface decisions by up to 66% on delay performance for example (on Figure 4.6-a). DURATS shows its benefits both in a scenario where only one application is deployed on a node or a scenario where all the three applications are deployed on a node. This by considering the QoS constraints of each of the applications. However, the proof of concept for such a hardware architecture is out of the scope of this work.

5.1.2 IEEE 802.15.4 MAC aware of IEEE 802.11

In the perspective of efficient coexistence of technologies, we studied the possibility of making the CSMA/CA algorithm of IEEE 802.15.4 network aware of information available for

IEEE 802.11 when operating on the same channel. The study is for two proposed backoff mechanisms that take into account channel reservation information announced in the control frames of IEEE 802.11 to improve both network throughput and overall energy efficiency. One mechanism is more preemptive than the other.

Results show that the proposed mechanisms improve the packet delivery ratio of the basic CSMA/CA by up to 26% on average under traffic load in a WLAN that does not exceed 40% of offered load. This is mainly due to an increase of awareness of the channel activity for IEEE 802.15.4 nodes. We also showed that with this enhancement, although we have fewer collisions and less energy consumption, the access delay of 802.15.4 frames is increased.

This work shows the benefits of sharing information about the channel occupation between wireless interfaces working on the same communication channels. This would motivate industries into thinking and developing differently communicating nodes having multiple wireless interfaces working on the same communication channels.

This study assumed that information for the 802.11 interfaces is available for the 802.15.4 interface. This can be made possible with a memory sharing mechanism for both interfaces to access information about channel occupancy.

5.1.3 Performance evaluation

We developed framework of heterogeneous network simulation by integrating the most popular network simulation modules in the OMNet++ ecosystem (INET and SimuLTE) to evaluate our proposals. INET is considered for IEEE protocol models such as 802.11 and 802.15.4, and IETF protocol models such as UDP. SimuLTE is considered for 3GPP protocol models such as LTE-D2D unicast. Thus, in contrast to all reviewed related work, our proposals' effectiveness and efficiency are evaluated using a full-stack network simulator which adds a more practical perspective to the results.

5.2 Perspectives

This section highlights possible future work base on this thesis contributions.

5.2.1 DURATS parameters study

DURATS overloads the network with background traffic to obtain more accurate channel estimations. One can evaluate its impact per application type and reduce it in future work. Furthermore, DURATS has parameters such as δ_{min} and δ_{max} respectively, guaranteeing a minimum and maximum size of the decision data. These parameters may have different optimal values depending, e.g., on the traffic model and application type. Thus, in future work, these parameters can also be studied.

5.2.2 Impact of higher layer protocols on DURATS

Indeed, DURATS decides on a per-packet basis. This means that packets of the same flow can be sent to different RATs, potentially leading to re-orderings within transport or application layer protocols. In future work, these re-orderings on transport or application layer protocols can be analyzed as they may impact the Quality-of-Experience (QoE) in terms of jitters. For example, when using TCP in a higher layer protocol, re-orderings may lead to useless re-transmissions (e.g., when the packet is not lost but just delayed) and rate reductions due to congestion control. This potential impact on QoE, can be reduced in future work with an extended DURATS that would decide not per-packet basis but by a burst of packets.

5.2.3 Enhanced DURATS decision data estimation

Decision data estimation is an essential mechanism in DURATS. It is achieved using a function that controls statistics intervals based on a data fluctuation metric, namely Coefficient of Variation (CV) as a parameter. This function aims to reduce decisions on underestimated or overestimated decision data, both resulting in undesirable or wrong decision making. We assumed that this function can be obtained using exponential modeling, and its benefits have been shown through a careful design of simulation scenario and traffic model. Thus, in the context of emerging and challenging networking uses of recent generation networks such as QoS Based Resource Optimizations and Flight Path Based Dynamic Unmanned Aerial Vehicle Resource Allocation of Open RAN initiatives, this function can be enhanced toward a robust and general purpose solution in future work. This can be done using another function modeling, such as machine learning techniques with additional function parameters to the data fluctuation metric.

5.2.4 Channel information sharing between more technologies

In our proposal of IEEE 802.15.4 MAC aware of IEEE 802.11, we considered that the priority was for IEEE 802.15.4 to avoid collisions and to lose energy doing so. Thus, we only worked on enhancing the CSMA/CA of 802.15.4. However, the proposed technique would be extended for enhancing the CSMA/CA of both protocols. In addition, the concept of information sharing can be extended to other technologies sharing the same channel and embedded on the same device. With the fast-growing deployment of 5G and beyond, other technologies might be candidates for such information sharing with more and more devices embedded with Wi-Fi and Bluetooth, which are two technologies that use the same communication channel also. Bluetooth does not use a CSMA/CA based access method, but the channel selection of its channel hopping technique might benefit from the NAV information, for example.

LIST OF PUBLICATIONS

Survey on wireless networks coexistence: resource sharing in the 5G era

In this paper [45], we survey existing communication protocols, techniques, and mechanisms, as well as features of the 5G communication standards that allow technology to cope well with coexistence. We also propose resource-sharing mechanisms that would positively impact the 5G infrastructure for better spectrum efficiency.

Interference study of coexisting IEEE 802.11 and 802.15.4 Networks

In this paper [44], we report an extension of an open-source simulation framework for OM-NeT++ (INET) to simulate interference impact on the coexistence of IEEE 802.11 and IEEE 802.15.4 in the 2.4GHz ISM bands. We extended the interference module of INET to take into account inter-technology and inter-channel interferences.

Enhancing the CSMA/CA of IEEE 802.15.4 for better coexistence with IEEE 802.11

In this paper [41], we propose backoff algorithms for IEEE 802.15.4 (WPAN) that take into account information collected at a multi-interface node to improve coexistence with IEEE 802.11 (WLAN). The proposed mechanisms benefit from a virtual Clear Channel Assessment given by the WLAN interface to improve both network throughput and overall energy efficiency.

Survey on decision-making algorithms for network selection in heterogeneous architectures

In this paper [43], we survey decision-making algorithms for network selection in heterogeneous communication architectures. We also propose a taxonomy of these algorithms and carry out a discussion about common design challenges related to their applicability.

DURATS: Distributed User-centric Radio Access Technology Selection framework

In this paper [40], we present DURATS: Distributed User-centric Radio Access Technology Selection framework formulated as a Multiple Criteria Decision Making problem in the decision-making step. A full-stack network simulator is used to prove the efficiency of this proposal.

REFERENCES

- [1] R. M. Abdullah, A. Z. Abualkishik, and A. A. Alwan. Improved handover decision algorithm using multiple criteria. *Procedia Computer Science*, 141:32 – 39, 2018. The 9th International Conference on Emerging Ubiquitous Systems and Pervasive Networks (EUSPN-2018) / The 8th International Conference on Current and Future Trends of Information and Communication Technologies in Healthcare (ICTH-2018) / Affiliated Workshops.
- [2] M. M. Ali. INET4.2 Patches, 2020.
- [3] J. T. Ali Mamadou Mamadou and G. Chalhoub. Interference Study of Co-existing IEEE 802.11 and 802.15.4 Networks. Invited paper. *IFIP/IEEE International Conference on Performance Evaluation and Modeling in Wired and Wireless Networks*, 2019.
- [4] N. M. Alotaibi and S. S. Alwakeel. A neural network based handover management strategy for heterogeneous networks. In *2015 IEEE 14th international conference on machine learning and applications (ICMLA)*, pages 1210–1214. IEEE, 2015.
- [5] I. S. association. IEEE 802.11g-2003 - IEEE Standard for Information technology– Local and metropolitan area networks– Specific requirements– Part 11: Wireless LAN Medium Access Control (MAC) and Physical Layer (PHY) Specifications: Further Higher Data Rate Extension in the 2.4 GHz Band, 2003.
- [6] I. S. association. IEEE 802.11ac - IEEE Standard for Information technology - Amendment 4: Enhancements for Very High Throughput for Operation in Bands below 6 GHz., 2013.
- [7] I. S. association. P802.11ax/D4.0 - IEEE Draft Standard for Information Technology – Telecommunications and Information Exchange Between Systems Local and Metropolitan Area Networks – Specific Requirements Part 11: Wireless LAN Medium Access Control (MAC) and Physical Layer (PHY) Specifications Amendment Enhancements for High Efficiency WLAN, Feb 2019.

- [8] R. Bismukhamedov, Y. Yeryomin, and J. Seitz. Evaluation of mcda-based handover algorithms for mobile networks. In *2016 Eighth International Conference on Ubiquitous and Future Networks (ICUFN)*, pages 810–815. IEEE, 2016.
- [9] K. H. Bindu, R. Morusupalli, N. Dey, and C. R. Rao. *Coefficient of variation and machine learning applications*. CRC Press, 2019.
- [10] R. G. Brown. *Smoothing, forecasting and prediction of discrete time series*. Courier Corporation, 2004.
- [11] R. A. Cacheda, D. C. García, A. Cuevas, F. J. G. Castano, J. H. Sánchez, G. Koltsidas, V. Mancuso, J. I. M. Novella, S. Oh, and A. Pantò. Qos requirements for multimedia services. In *Resource management in satellite networks*, pages 67–94. Springer, 2007.
- [12] G. Chalhoub, E. Perrier de La Bathie, and M. Misson. Overhead caused by WiFi on ZigBee Networks using Slotted CSMA/CA. *Journal of Networks*, Feb. 2016.
- [13] Chong, Jo Woon and Cho, Chae Ho and Hwang, Ho Young and Sung, Dan Keun. An adaptive WLAN interference mitigation scheme for Zig-Bee sensor networks. *International Journal of Distributed Sensor Networks*, 11(8):851289, 2015.
- [14] F. C. Commission. 'Notice of proposed rule making and order: Facilitating opportunities for flexible, efficient, and reliable spectrum use employing cognitive radio technologies', ET Docket No. 03-108, Feb. 2005., 2005. Accessed 19 June 2019.
- [15] O. Community. INET Framework, 2020.
- [16] S.-C. . G. I. . Compliant and Z. R. R. T. D. Sheet. Texas Instruments, 2021.
- [17] I. Computer Networking Group of the University of Pisa. LTE User Plane Simulation Model for INET & OMNeT++, 2020.

- [18] C. Cordeiro and K. Challapali. C-MAC: A Cognitive MAC Protocol for Multi-Channel Wireless Networks. In *2007 2nd IEEE International Symposium on New Frontiers in Dynamic Spectrum Access Networks*, pages 147–157, April 2007.
- [19] C. Cormio and K. R. Chowdhury. A survey on mac protocols for cognitive radio networks. *Ad Hoc Networks*, 7(7):1315 – 1329, 2009.
- [20] E. Demirors, G. Sklivanitis, T. Melodia, and S. N. Batalama. RcUBE: Real-time reconfigurable radio framework with self-optimization capabilities. In *2015 12th Annual IEEE International Conference on Sensing, Communication, and Networking (SECON)*, pages 28–36. IEEE, 2015.
- [21] C. Doerr, M. Neufeld, J. Fifield, T. Weingart, D. C. Sicker, and D. Grunwald. MultiMAC - an adaptive MAC framework for dynamic radio networking. In *First IEEE International Symposium on New Frontiers in Dynamic Spectrum Access Networks, 2005. DySPAN 2005.*, pages 548–555, Nov 2005.
- [22] A. D. Domenico, E. C. Strinati, and M. D. Benedetto. A Survey on MAC Strategies for Cognitive Radio Networks. *IEEE Communications Surveys Tutorials*, 14(1):21–44, First 2012.
- [23] E. Dopazo and J. González-Pachón. Consistency-driven approximation of a pairwise comparison matrix. *Kybernetika*, 39(5):561–568, 2003.
- [24] I. El Fachtali, R. Saadane, and M. ElKoutbi. Vertical handover decision algorithm using ants’ colonies for 4g heterogeneous wireless networks. *Journal of Computer Networks and Communications*, 2016, 2016.
- [25] A. Farago, A. D. Myers, V. R. Syrotiuk, and G. V. Zaruba. Meta-MAC protocols: automatic combination of MAC protocols to optimize performance for unknown conditions. *IEEE Journal on Selected Areas in Communications*, 18(9):1670–1681, Sep. 2000.
- [26] S. Goudarzi, W. H. Hassan, M. H. Anisi, A. Soleymani, M. Sookhak, M. K. Khan, A.-H. A. Hashim, and M. Zareei. Abc-pso for vertical handover in heterogeneous wireless networks. *Neurocomputing*, 256:63–81, 2017.

- [27] A. Habbal, S. I. Goudar, and S. Hassan. A context-aware radio access technology selection mechanism in 5g mobile network for smart city applications. *Journal of Network and Computer Applications*, 135:97–107, 2019.
- [28] E. Haghani, M. N. Krishnan, and A. Zakhor. A method for estimating access delay distribution in ieee 802.11 networks. In *2011 IEEE Global Telecommunications Conference - GLOBECOM 2011*, pages 1–6, 2011.
- [29] A. Huszak and S. Imre. Eliminating rank reversal phenomenon in gra-based network selection method. In *2010 IEEE International Conference on Communications*, pages 1–6. IEEE, 2010.
- [30] P. H. Isolani, M. Claeys, C. Donato, L. Z. Granville, and S. Latré. A Survey on the Programmability of Wireless MAC Protocols. *IEEE Communications Surveys Tutorials*, pages 1–1, 2018.
- [31] B. Jooris, J. Bauwens, P. Ruckebusch, P. De Valck, C. Van Praet, I. Moerman, and E. De Poorter. Taise: a cross-platform mac protocol compiler and execution engine. *Computer Networks*, 107:315–326, 2016.
- [32] O. Khattab and O. Alani. Algorithm for seamless vertical handover in heterogeneous mobile networks. In *2014 Science and Information Conference*, pages 652–659. IEEE, 2014.
- [33] K. Khawam, S. Lahoud, M. Ibrahim, M. Yassin, S. Martin, M. E. Helou, and F. Moety. Radio access technology selection in heterogeneous networks. *Physical Communication*, 18:125 – 139, 2016. Special Issue on Radio Access Network Architectures and Resource Management for 5G.
- [34] E. Khorov, A. Kiryanov, A. Lyakhov, and G. Bianchi. A Tutorial on IEEE 802.11ax High Efficiency WLANs. *IEEE Communications Surveys Tutorials*, pages 1–1, 2018.
- [35] J. Kim, W. Jeon, K.-J. Park, and J. P. Choi. Coexistence of full-duplex-based ieee 802.15. 4 and ieee 802.11. *IEEE Transactions on Industrial Informatics*, 14(12):5389–5399, 2018.

- [36] T.-S. Kim, T. Park, M. Sha, and C. Lu. Toward MAC Protocol Service over the air. In *2012 IEEE Global Communications Conference (GLOBECOM)*, pages 451–457, Dec 2012.
- [37] S. Kunarak and R. Sulesathira. Vertical handover decision management on the basis of several criteria for lmqnn with ubiquitous wireless networks. *International Journal of GEOMATE*, 12(34):123, 2017.
- [38] P. Li, Y. Yan, P. Yang, X. Li, and Q. Lin. Coexist wifi for zigbee networks with fine-grained frequency approach. *IEEE Access*, 7:135363–135376, 2019.
- [39] S. . Lien, C. . Tseng, and K. . Chen. Carrier Sensing Based Multiple Access Protocols for Cognitive Radio Networks. In *2008 IEEE International Conference on Communications*, pages 3208–3214, May 2008.
- [40] A. M. Mamadou and G. Chalhoub. Durats: Distributed user-centric radio access technology selection framework. In *2021 17th International Conference on Wireless and Mobile Computing, Networking and Communications (WiMob)*, pages 289–294. IEEE, 2021.
- [41] A. M. Mamadou and G. Chalhoub. Enhancing the csma/ca of ieee 802.15.4 for better coexistence with ieee 802.11. *Wireless Networks*, 27(6):3903–3914, 2021.
- [42] A. M. Mamadou, M. Karoui, G. Chalhoub, and A. Freitas. Survey on decision-making algorithms for network selection in heterogeneous architectures. In *Communication Technologies for Vehicles*, pages "89–98". Springer, 2020.
- [43] A. M. Mamadou, M. Karoui, G. Chalhoub, and A. Freitas. Survey on decision-making algorithms for network selection in heterogeneous architectures. In *International Workshop on Communication Technologies for Vehicles*, pages 89–98. Springer, 2020.

- [44] A. M. Mamadou, J. Toussaint, and G. Chalhoub. Interference study of coexisting IEEE 802.11 and 802.15.4 networks. In *2019 8th International Conference on Performance Evaluation and Modeling in Wired and Wireless Networks (PEMWN)*, pages 1–5. IEEE, 2019.
- [45] A. M. Mamadou, J. Toussaint, and G. Chalhoub. Survey on wireless networks coexistence: resource sharing in the 5G era. *Mobile Networks and Applications*, 25(5):1749–1764, 2020.
- [46] W. Mansouri, F. Zarai, K. Mnif, and L. Kamoun. Cross layer architecture with integrated mih in heterogeneous wireless networks. *Computer Networks*, 127:126–137, 2017.
- [47] J. Marinho and E. Monteiro. Cognitive radio: survey on communication protocols, spectrum decision issues, and future research directions. *Wireless Networks*, 18(2):147–164, Feb 2012.
- [48] P. Naghavi, S. H. Rastegar, V. Shah-Mansouri, and H. Kebriaei. Learning rat selection game in 5g heterogeneous networks. *IEEE Wireless Communications Letters*, 5(1):52–55, 2015.
- [49] L. Ning, Z. Wang, Q. Guo, and K. Jiang. Fuzzy clustering based group vertical handover decision for heterogeneous wireless networks. In *2013 IEEE Wireless Communications and Networking Conference (WCNC)*, pages 1231–1236. IEEE, 2013.
- [50] S. Nishikori, K. Kinoshita, Y. Tanigawa, H. Tode, and T. Watanabe. A cooperative channel control method of ZigBee and WiFi for IoT services. In *2017 14th IEEE Annual Consumer Communications & Networking Conference (CCNC)*, pages 1–6. IEEE, 2017.
- [51] C. P. N. Online. Handset Connectivity Technologies - 4th Edition , 2013.
- [52] S. Opricovic and G.-H. Tzeng. Compromise solution by mcdm methods: A comparative analysis of vikor and topsis. *European journal of operational research*, 156(2):445–455, 2004.

- [53] K. Oshima, T. Onishi, S.-J. Kim, J. Ma, and M. Hasegawa. Efficient wireless network selection by using multi-armed bandit algorithm for mobile terminals. *Nonlinear Theory and Its Applications, IEICE*, 11(1):68–77, 2020.
- [54] R. Paul and Y. J. Choi. Autonomous interface selection for multi-radio d2d communication. *IEEE Access*, 7:108090–108100, 2019.
- [55] K. Piamrat, A. Ksentini, J.-M. Bonnin, and C. Viho. Radio resource management in emerging heterogeneous wireless networks. *Computer Communications*, 34(9):1066–1076, 2011.
- [56] C. public. The fifth generation of wifi, Technical White Paper, 2018. Accessed 19 June 2019.
- [57] M. Qiao, H. Zhao, S. Wang, and J. Wei. MAC protocol selection based on machine learning in cognitive radio networks. In *2016 19th International Symposium on Wireless Personal Multimedia Communications (WPMC)*, pages 453–458, Nov 2016.
- [58] Z. Qin, Y. Sun, J. Hu, W. Zhou, and J. Liu. Enhancing efficient link performance in zigbee under cross-technology interference. *Mobile Networks and Applications*, 25(1):68–81, 2020.
- [59] R. B. Rayana and J.-M. Bonnin. A smart management framework for multihomed mobile nodes & mobile routers. In *2009 IEEE 20th International Symposium on Personal, Indoor and Mobile Radio Communications*, pages 2881–2885. IEEE, 2009.
- [60] A. Rouskas, P. Kosmides, A. Kikilis, and M. Anagnostou. Rat selection optimization in heterogeneous wireless networks. In *International Conference on Broadband Communications, Networks and Systems*, pages 460–472. Springer, 2010.
- [61] C. Shao, H. Park, H. Roh, and W. Lee. Dota: Physical-layer decomposing and threading for zigbee/wi-fi co-transmission. *IEEE Wireless Communications Letters*, 8(1):133–136, 2018.

- [62] Shu, Feng and Sakurai, Taka and Zukerman, Moshe and Vu, Hai L. Packet loss analysis of the IEEE 802.15.4 MAC without acknowledgements. *IEEE communications letters*, 11(1):79–81, 2007.
- [63] P. Steenkiste, G. Nychis, and S. Seshan. Enabling mac protocol implementations on software-defined radios. In *Proceedings of the 6th USENIX Symposium on Networked Systems Design and Implementation*, 2009.
- [64] T. Sugimoto, N. Komuro, H. Sekiya, S. Sakata, and K. Yagyu. Maximum throughput analysis for rts/cts-used ieee 802.11 dcf in wireless multi-hop networks. In *International Conference on Computer and Communication Engineering (ICCCE'10)*, pages 1–6, 2010.
- [65] G. K. Thakur, B. Priya, and P. K. Sharma. Optimal selection of network in heterogeneous environment based on fuzzy approach. *J. Math. Comput. Sci.*, 10(3):554–571, 2020.
- [66] F. Tobagi and L. Kleinrock. Packet switching in radio channels: Part ii-the hidden terminal problem in carrier sense multiple-access and the busy-tone solution. *IEEE Transactions on communications*, 23(12):1417–1433, 1975.
- [67] P. N. Tran and N. Boukhatem. Comparison of MADM decision algorithms for interface selection in heterogeneous wireless networks. In *2008 16th international conference on software, telecommunications and computer networks*, pages 119–124. IEEE, 2008.
- [68] R. Trestian, O. Ormond, and G.-M. Muntean. Performance evaluation of madm-based methods for network selection in a multimedia wireless environment. *Wireless Networks*, 21(5):1745–1763, 2015.
- [69] J. Umer, H. Di, L. Peilin, and Y. Yueming. Frequency hopping in IEEE 802.15.4 to mitigate IEEE 802.11 interference and fading. *Journal of Systems Engineering and Electronics*, 29(3):445–455, 2018.
- [70] I. T. Union. M.2083 : IMT Vision - "Framework and overall objectives of the future development of IMT for 2020 and beyond", 2015-09. Accessed 20 June 2019.

- [71] Vikram, K and Sahoo, Sarat Kumar. A collaborative framework for avoiding interference between Zigbee and WiFi for effective smart metering applications. *Electronics*, 22(1):48–56, 2018.
- [72] A. Viridis, G. Nardini, and G. Stea. Modeling unicast device-to-device communications with simulte. In *2016 1st International Workshop on Link-and System Level Simulations (IWSLS)*, pages 1–6. IEEE, 2016.
- [73] L. Wang and G.-S. G. Kuo. Mathematical modeling for network selection in heterogeneous wireless networks—a tutorial. *IEEE Communications Surveys & Tutorials*, 15(1):271–292, 2012.
- [74] L. Wu and K. Sandrasegaran. A Survey on Common Radio Resource Management. In *The 2nd International Conference on Wireless Broadband and Ultra Wideband Communications (AusWireless 2007)*, pages 66–66, Aug 2007.
- [75] X. Wu and Q. Du. Utility-function-based radio-access-technology selection for heterogeneous wireless networks. *Computers & Electrical Engineering*, 52:171 – 182, 2016.
- [76] D. Yang, Y. Xu, and M. Gidlund. Wireless coexistence between IEEE 802.11-and IEEE 802.15. 4-based networks: A survey. *International Journal of Distributed Sensor Networks*, 7(1):912152, 2011.
- [77] P. Yang, Y. Yan, X.-Y. Li, Y. Zhang, Y. Tao, and L. You. Taming cross-technology interference for wi-fi and zigbee coexistence networks. *IEEE Transactions on Mobile Computing*, 15(4):1009–1021, 2015.
- [78] S. Yau, L. Ge, P.-C. Hsieh, I.-H. Hou, S. Cui, P. Kumar, A. Ekbal, and N. Kundargi. WiMAC: Rapid implementation platform for user definable MAC protocols through separation. *ACM SIGCOMM Computer Communication Review*, 45(4):109–110, 2015.
- [79] H.-W. Yu and B. Zhang. A heterogeneous network selection algorithm based on network attribute and user preference. *Ad Hoc Networks*, 72:68–80, 2018.

APPENDIX A

TABLE 5.1 Simulation parameters for evaluation of IEEE 802.15.4 and IEEE 802.11 coexistence techniques.

WPAN	
<i>parameter</i>	<i>value</i>
CSMA/CA version	unslotted
aUnitBackoffPeriod duration	320 μ s
macMaxCSMABackoffs	4
backoff method	exponential
macMinBE	3
macMaxBE	5
Channel number	20
Frame payload length	88 bytes
use MAC ACKs	no
WLAN	
<i>parameter</i>	<i>value</i>
Channel number	9
Frame payload length	1500 bytes
Common	
<i>parameter</i>	<i>value</i>
Traffic	UDP
Routing	static

TABLE 5.2 Standard deviation values of the averages related to the WLAN metrics with 40 % of the offered load rounded to two decimal places.

WLAN data rate	CSMA in WPAN	B-CSMA	A-CSMA-1	A-CSMA-2
Absolute throughput Std Dev				
6Mbps		0.00e+00	0.00e+00	4.00e-05
54Mbps		1.80e-03	2.08e-03	7.92e-03
Relative throughput Std Dev				
6Mbps		0.00e+00	0.00e+00	6.67e-04
54Mbps		3.34e-03	3.85e-03	1.47e-02
Channel occupancy ratio Std Dev				
6Mbps		1.34e-02	9.79e-03	7.46e-02
54Mbps		1.30e-02	2.23e-02	2.80e-02
Overhead channel occupancy ratio Std Dev				
6Mbps		1.43e-03	2.85e-03	1.94e-03
54Mbps		7.73e-03	1.36e-02	1.46e-02

TABLE 5.3 Standard deviation values of the averages related to the WPAN metrics rounded to two decimal places.

Scenario \ Offered load	0%	10%	20%	30%	40%	60%	80%	100%
Packet loss ratio Std Dev								
B-CSMA-6Mbps	3.08e-01	3.86e-01	2.72e-01	2.20e-01	2.12e-01	1.39e-01	1.21e-01	2.90e-01
B-CSMA-54Mbps	3.25e-01	3.47e-01	3.14e-01	5.77e-01	6.29e-01	4.93e-01	4.83e-01	5.16e-01
A-CSMA-1-6Mbps	3.29e-01	4.05e-01	2.48e-01	3.20e-01	2.25e-01	4.07e-01	7.70e-03	0.00e+00
A-CSMA-1-54Mbps	3.33e-01	4.46e-01	4.95e-01	4.34e-01	1.61e-01	7.59e-03	3.54e-03	5.94e-03
A-CSMA-2-6Mbps	3.34e-01	3.31e-01	4.21e-01	3.54e-01	2.99e-01	3.86e-01	3.90e-01	2.22e-01
A-CSMA-2-54Mbps	3.23e-01	4.40e-01	5.95e-01	7.70e-01	1.25e+00	3.70e-01	2.10e-01	1.93e-01
Failed transmission attempts Std Dev								
B-CSMA-6Mbps	6.05e+00	5.60e+00	5.08e+00	4.93e+00	5.06e+00	-	-	-
B-CSMA-54Mbps	6.33e+00	4.92e+00	3.95e+00	4.08e+00	70e+00	-	-	-
A-CSMA-1-6Mbps	5.03e+00	6.09e+00	3.66e+00	5.38e+00	2.33e+01	-	-	-
A-CSMA-1-54Mbps	4.55e+00	4.40e+00	3.86e+00	1.69e+01	2.11e+00	-	-	-
A-CSMA-2-6Mbps	4.82e+00	5.68e+00	8.48e+00	3.76e+00	6.04e+00	-	-	-
A-CSMA-2-54Mbps	4.35e+00	5.01e+00	6.55e+00	5.89e+00	1.14e+01	-	-	-
Access delay Std Dev								
B-CSMA-6Mbps	4.32e-02	4.39e-02	4.67e-02	5.48e-02	5.48e-02	-	-	-
B-CSMA-54Mbps	4.60e-02	2.73e-02	7.61e-02	7.86e-02	2.21e-01	-	-	-
A-CSMA-1-6Mbps	5.45e-02	9.95e-02	1.33e-01	3.19e-01	1.40e+00	-	-	-
A-CSMA-1-54Mbps	4.52e-02	7.63e-02	1.84e-01	2.68e+00	3.87e+03	-	-	-
A-CSMA-2-6Mbps	5.28e-02	5.33e-02	1.01e-01	8.29e-02	2.26e-01	-	-	-
A-CSMA-2-54Mbps	5.12e-02	5.39e-02	7.57e-02	1.38e-01	5.39e-01	-	-	-