



HAL
open science

Robust analysis of uncertain descriptor systems using non quadratic Lyapunov functions

Ana Carolina dos Santos Paulino

► **To cite this version:**

Ana Carolina dos Santos Paulino. Robust analysis of uncertain descriptor systems using non quadratic Lyapunov functions. Automatic. Université de Strasbourg, 2018. English. NNT : 2018STRAD049 . tel-03907315

HAL Id: tel-03907315

<https://theses.hal.science/tel-03907315>

Submitted on 20 Dec 2022

HAL is a multi-disciplinary open access archive for the deposit and dissemination of scientific research documents, whether they are published or not. The documents may come from teaching and research institutions in France or abroad, or from public or private research centers.

L'archive ouverte pluridisciplinaire **HAL**, est destinée au dépôt et à la diffusion de documents scientifiques de niveau recherche, publiés ou non, émanant des établissements d'enseignement et de recherche français ou étrangers, des laboratoires publics ou privés.

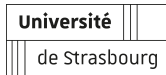

UNIVERSITY OF STRASBOURG



MSII GRADUATE SCHOOL: "MATHÉMATIQUES, SCIENCES DE
L'INFORMATION ET DE L'INGÉNIEUR"

THESIS PRESENTED BY

ANA CAROLINA DOS SANTOS PAULINO

ON DECEMBER 12th, 2018

submitted in fulfillment of the requirements for the degree of **Doctor of
Philosophy of the University of Strasbourg**

Area/Speciality: **Control theory**

**Robust analysis of uncertain descriptor
systems using non quadratic Lyapunov
functions**

THESIS supervised by:

Gabriela Iuliana BARA, Assistant professor at University of Strasbourg, HDR

EXTERNAL REPORTERS:

Cristina MANIU, Assistant professor at CentraleSupélec, HDR

Germain GARCIA, University professor at INSA of Toulouse

OTHER MEMBERS OF THE JURY:

Rachid OUTBIB, University professor at University of Aix-Marseille

Édouard LAROCHE, University professor at University of Strasbourg

Acknowledgements

My many thanks to the French Ministry of Higher Education, Research and Innovation (MENESR) that invested in this research project throughout the three years of my thesis and for the University of Strasbourg, that first hosted me as a master student in *Télécom Physique Strasbourg*, and then as a PhD fellow, monitor in control related subjects and member of its research committee.

My sincere thanks to my supervisor, Iulia, who has been my teacher and mentor throughout all my academic journey in France. I am glad to have witnessed your rigorous and passionate engagement with knowledge, and for having been exposed to the mindset of such an experienced researcher. I am profoundly thankful that you entrusted me this project that became a life-changing experience.

I believe the working environment has significant influence in the motivation and in quality of the work of its collaborators. In this sense, the ICube laboratory is an exceptional place. During this three years affiliated to the laboratory, I could learn with and be encouraged by former teachers and current colleagues. Thank you all for the numerous exchanges. Furthermore, among my contemporary PhD fellows and master interns, I found cherished friendships. My heartfelt thanks to Imane, Chinmay, Lijia, Devesh, Rima, Maximilian and others.

I would also like to address my thanks to friends who, despite being outside the campus in Illkirch and even away from the academic world, have been tender support and cheerful encouragement: my fellows from *Église Baptiste de Strasbourg* and *Groupes Bibliques Universitaires*. I also thank Marcela for the inspiration and for the joyful hopes on the future.

Meus agradecimentos sinceros aos meus pais, Natanael e Ana Lúcia, por tantos sacrifícios e por tanto amor. Eu certamente não estaria aqui sem os senhores.

Chinmay, thank you for everything.

My deepest gratitude to God for everything I could live, learn and synthesize in this thesis.

And, finally, my acknowledgments to all the future readers for your attention, time and interest.

Contents

Acknowledgements	iii
Introduction générale	1
Introduction	7
1 Theoretical background	13
1.1 LTI descriptor systems	14
1.1.1 Examples	15
1.1.2 The singular value decomposition (SVD) normal form	17
1.1.3 Properties of descriptor systems	18
1.1.4 Admissibility analysis of descriptor systems	23
1.2 Standard uncertain systems	26
1.2.1 Example	27
1.2.2 Parameter-dependent systems	27
1.2.3 Stability analysis of uncertain systems	32
1.2.4 Mathematical tools for numerical tractability	36
1.2.5 Homogeneous Polynomial Lyapunov functions	40
1.3 Uncertain descriptor systems	42
1.3.1 Example	43
1.3.2 The singular value decomposition normal form	44
1.3.3 Properties of uncertain descriptor systems	45
1.3.4 Polytopic/affine uncertain descriptor systems	45
1.3.5 Admissibility analysis of uncertain descriptor systems	46
1.3.6 Mathematical tools for numerical tractability	50
1.4 Conclusion	52
2 Admissibility analysis of discrete-time time-varying descriptor systems	53
2.1 Introduction	53
2.2 Time-varying (TV) descriptor systems	53
2.2.1 Class of systems	54
2.2.2 New admissibility analysis conditions for TV descriptor systems	55
2.3 Polytopic descriptor systems	56
2.3.1 Parameters' variation space	57
2.3.2 Structure of slack variables	58

2.3.3	New admissibility analysis conditions for polytopic descriptor systems	60
2.3.4	Numerical Examples	60
2.4	Conclusion	66
3	Extension of homogeneous polynomial Lyapunov functions approach to continuous-time uncertain descriptor systems	67
3.1	Introduction	67
3.2	Affine parameter-dependent standard uncertain systems	68
3.2.1	Class of systems and HPLF	68
3.2.2	Linear mapping between the original and extended standard uncertain systems	69
3.3	Affine parameter-dependent descriptor systems	72
3.3.1	Class of systems	73
3.3.2	Parameter-independent homogeneous polynomial Lyapunov functions	73
3.3.3	Numerical examples	76
3.4	Conclusion	78
4	Admissibility analysis of continuous-time uncertain descriptor systems by parameter-dependent homogeneous polynomial Lyapunov functions	79
4.1	Introduction	79
4.2	Polytopic uncertain descriptor systems	80
4.2.1	Class of systems	80
4.2.2	Parameters' variation space	80
4.3	Admissibility analysis based on polytopic HPLFs	81
4.3.1	Numerical examples	87
4.4	Admissibility analysis based on homogeneously parameter-dependent HPLFs	92
4.4.1	Numerical examples	97
4.4.2	Evaluation of robust admissibility margins and comparison with results from the literature	97
4.4.3	Evaluation of the maximum allowed parameters' rates of variation for different values of robust admissibility margins	99
4.5	Conclusion	99
5	Conclusions and perspectives	103
5.1	Summary of the thesis	103
5.2	Perspectives	104
A	Mathematical tools	107
A.1	Positive-definiteness of a matrix	107
A.2	The convex hull [BV01]	107

A.3 Kronecker product	107
A.4 Norms	108
A.5 Linear Matrix Inequalities (LMIs) [SW99]	108
A.6 Schur complement	108
A.7 Finsler's lemma - Variant of [BSC12]	109
A.8 Permutation matrix [Bre78]	109
A.9 Toolboxes	109
Bibliography	111

List of Figures

1.1	Relationship between linear time-invariant (LTI), linear parameter-varying (LPV) and linear time-varying (LTV) systems	14
1.2	A RLC circuit network	15
1.3	A mechanical system	16
1.4	An electromechanical circuit	27
4.1	Example 3: Maximum allowed velocities of parameters for imposed admissibility margins $\kappa_{2q \cdot }^*$ under conditions of Theorem 4.3.7 for PPD-HPLFs of different orders	91
4.2	Example 3: Maximum allowed velocities of parameters β for increasing values of κ_{2q}^* and different degrees s on the parameter vector. Every figure is traced for a fixed degree q of state vector.	100
4.3	Example 3: Maximum allowed velocities β of parameters for increasing κ_{2q}^* for different degrees q of the state vector, and fixed degree $s = 2$ for the parameter vector.	101

List of Tables

2.1	Choices of indicator functions and their implications over a matrix $M(w(k), w(k + 1))$	59
2.2	Robust admissibility margins κ for different analysis techniques	65
3.1	κ_{2q+1}^* obtained for Example 2	78
4.1	$\kappa_{2q+}^*(100)$ for Example 1	90
4.2	$\kappa_{2q+}^*(50)$ for Example 2	90
4.3	$\kappa_{2q}^*(\beta)$ for Example 3	92
4.4	$\kappa_{2q+}^*(50)$ for Example 2	98
4.5	$\kappa_{2q+}^*(5)$ for Example 3	99

Nomenclature

Sizes

m	Size of the parameter vector w
N	Number of elements of the convex hull \mathcal{W}
n	Size of the dynamic state vector x
n_{ξ}	Size of the algebraic state vector ξ
q	Degree of the power transform on the state vector x

Vectors

x	Dynamic state vector	$x \in \mathbb{R}^n$
ξ	Algebraic state vector	$\xi \in \mathbb{R}^{n_{\xi}}$
X	General state vector	$X \in \mathbb{R}^{(n+n_{\xi})}$
w	Parameter vector, belonging to the convex set \mathcal{W}	$w \in \mathbb{R}^m$
v	Parameter's rate of variation vector, belonging to the convex set \mathcal{V}	$v \in \mathbb{R}^m$
b	Bound on parameter's variation	$b \in \mathbb{R}^m$
d	Vertex of \mathcal{V}	$d \in \mathbb{R}^m$

Matrices

A	Dynamic matrix	$A \in \mathbb{R}^{(n+n_{\xi}) \times (n+n_{\xi})}$
E	Derivative matrix	$E \in \mathbb{R}^{(n+n_{\xi}) \times (n+n_{\xi})}$
P	Lyapunov matrix	
$F, \mathcal{F}, G, \mathcal{G}$	Slack variables	

Functions

η, ρ Indicator functions used in Chapter 2 for selecting the degrees of freedom in LMI conditions

$V(X, w, t)$ Lyapunov function

Sets

\mathcal{V} Convex hull of the parameter's rate of variation vector v $\text{Co}\{v\}$

\mathcal{W} Convex hull of the parameter vector w $\text{Co}\{w\}$

Notations

$0^{n \times n_\xi}$ Zero matrix of size $n \times n_\xi$ $0^{n \times n_\xi} \in \mathbb{R}^{n \times n_\xi}$

0_{n_ξ} Zero matrix of size $n_\xi \times n_\xi$ $0_{n_\xi} \in \mathbb{R}^{n_\xi \times n_\xi}$

$\text{Bdiag}(I_n, 0_{n_\xi})$ Block diagonal matrix given by $\begin{bmatrix} I_n & 0^{n \times n_\xi} \\ 0^{n_\xi \times n} & 0_{n_\xi} \end{bmatrix}$. For the sake of visibility, $\begin{bmatrix} I_n & \\ & 0_{n_\xi} \end{bmatrix}$ is an equivalent representation.

$\text{Co}\{w\}$ Convex hull of w : the set containing all the convex combinations of vectors w [BV01]

$\text{deg}(S)$ Degree of a polynomial expression given by S

$\det(A)$ Determinant of the matrix A

$\dim(X)$ Dimension of a vector X : $\dim(X) = n + n_\xi$

$\mathcal{H}e(A)$ Sum between a matrix and its transpose $\mathcal{H}e(A) = A + A^T$

\mathbb{R}^n Set of real vectors of size n

$\mathbb{R}^{n \times n}$ Set of real matrices of size $n \times m$

\star Matrix block induced by symmetry $\begin{bmatrix} R & \star \\ S & T \end{bmatrix} = \begin{bmatrix} R & S^T \\ S & T \end{bmatrix}$

$\sup\{S\}$ Supremum of a set S

E_0 Orthogonal complement of $E \in \mathbb{R}^{(n+n_\xi) \times (n+n_\xi)}$, $\text{rank}(E) = n$, leading to $E^T E_0 = 0^{(n+n_\xi) \times n_\xi}$ $E_0 \in \mathbb{R}^{(n+n_\xi) \times n_\xi}$

I_n Identity matrix of size n $I_n \in \mathbb{R}^{n \times n}$

$sqr(w)$ Vector whose entries are the square roots of the entries of vector w

$$sqr(w) = \left[\sqrt{w_1} \quad \sqrt{w_2} \quad \dots \quad \sqrt{w_m} \right]^T$$

$sq(w)$ Vector whose entries are the square of the entries of vector w

$$sq(w) = \left[w_1^2 \quad w_2^2 \quad \dots \quad w_m^2 \right]^T$$

Acronyms

CSMR Complete Square Matricial Representation

HPD-HPLF Homogeneously Parameter-Dependent Homogeneous Polynomial Lyapunov Function

HPLF Homogeneous Polynomial Lyapunov Function

LMI Linear Matrix Inequality

LPV Linear Parameter Varying

LTI Linear Time-Invariant

LTV Linear Time-Varying

PPD-HPLF Polytopic Parameter-Dependent Homogeneous Polynomial Lyapunov Function

SMR Square Matricial Representation

SVD Singular Value Decomposition

In memory of my grandmother, Genésia dos Santos.

Introduction générale

La compréhension et l'asservissement des systèmes physiques qui nous entourent s'expriment souvent par le biais d'un langage mathématique. La théorie des systèmes dynamiques est développée depuis des siècles et permet la modélisation abstraite des systèmes concrets à travers des observations, mesures et validations. Toutefois, cette traduction du monde réel dans un formalisme mathématique dépend de la précision de la description. Bien évidemment, des erreurs de mesure et la manque de précision peuvent produire un modèle erroné voir incapable de fournir des prédictions fiables du comportement d'un système. En effet, la description de la réalité est une tâche difficile, pouvant être soit excessivement complexe et superflue, soit trop simpliste pour une application spécifique. Par exemple, dans les expérimentations d'école, telles que prédire l'arrivée d'une balle lancée au sol, nous n'avons pas besoin de précision élevée. Au contraire, dans les domaines médical et aérospatial, des erreurs ou des événements imprévus peuvent mener à des pertes irréparables [Gar03; Has+08]. Ainsi, il existe un compromis entre la précision et la simplicité dans la modélisation d'un système, et ce compromis doit être effectué en fonction du contexte et de l'application.

Le formalisme mathématique proposé par les *systèmes incertains* fournit une bonne précision avec une complexité abordable pour plusieurs domaines d'applications tels que l'aéronautique, la robotique et les applications industrielles, entre autres. Les systèmes incertains sont classifiés comme étant entre les systèmes linéaires et non-linéaires parce qu'ils représentent une famille paramétrée de systèmes linéaires. Ces paramètres peuvent être variables dans le temps, ce qui mène à une dynamique également variable dans le temps. La représentation compacte des systèmes incertains est très convenable, permettant non seulement l'étude de la stabilité de toute la famille de systèmes à la fois, mais aussi la synthèse de correcteurs qui maintiendront le comportement souhaité de cette famille en dépit des variations paramétriques. Bien que cette représentation reste puissante et polyvalente, elle peut engendrer des difficultés et, par conséquent, un certain conservatisme dans le développement des résultats d'analyse. Comme illustration, il peut être impossible de certifier la stabilité d'un système incertain stable par le biais d'une fonction de Lyapunov quadratique. Cela est dû au fait que la classe de fonctions de Lyapunov quadratiques n'est pas universelle pour la classe de systèmes incertains. La propriété d'universalité d'une fonction de Lyapunov consiste dans l'équivalence entre la stabilité d'un système et l'existence d'une fonction de Lyapunov dans cette classe qui vérifie sa stabilité. Une difficulté complémentaire de ce large formalisme est le domaine de vérification. Étant donnée que les paramètres d'un système incertain sont passibles de varier dans un intervalle

réel compact, une infinité de tests est requise pour s'assurer que chaque réalisation possible d'un système incertain est stable. À cause de cela, des techniques de convexification sont utilisées pour rendre possible la résolution numérique du problème, ce qui normalement augmente le conservatisme de l'évaluation. En effet, la recherche de techniques qui réduisent le conservatisme dans l'analyse des systèmes incertains est cruciale et reste un domaine ouvert.

Dans la littérature, on retrouve différentes techniques pour aborder le problème de l'analyse et de la commande des systèmes incertains. Plusieurs de ces techniques ont comme motivation la réduction du conservatisme. Ci-dessous, quelques uns de ces travaux sont évoqués, étant organisés par le type de systèmes qu'ils adressent.

Pour les systèmes incertains à *paramètres invariants dans le temps*, l'article [OBG99] présente des conditions pour l'analyse de stabilité des systèmes incertains à temps discret par le biais d'une fonction de Lyapunov indépendante des paramètres et une fonction de Lyapunov dépendant des paramètres. Dans l'étape de résolution numérique, l'utilisation des variables faibles est proposée. Ces techniques sont devenues la base de plusieurs travaux qui utilisent des variables faibles dans des conditions sous la forme d'inégalités linéaires matricielles (LMIs). Les travaux dans [Pea+00] proposent des conditions pour l'analyse de D-stabilité robuste des systèmes à temps continu et à temps discret avec des incertitudes polytopiques par l'utilisation des fonctions de Lyapunov dépendantes des paramètres et des variables faibles. Dans les travaux de [RP01], la stabilité robuste des systèmes incertains à temps discret ayant des paramètres variants dans le temps est étudiée par l'existence d'une fonction de Lyapunov dépendante des paramètres. Les conditions obtenues sont bornées par des scalaires obtenus de la majoration de polynômes semi-définis positifs. En [RP02], les résultats mentionnés précédemment sont étendus au cas des systèmes incertains à temps continu. Dans [Che+03b], une fonction de Lyapunov quadratique dans le vecteur d'état et homogène dans le vecteur des paramètres est proposée pour l'analyse de stabilité des systèmes incertains à temps continu. La possibilité d'étendre ces résultats au cas à temps discret y est évoquée.

Pour les systèmes incertains ayant des *paramètres variants dans le temps* avec des taux de variation bornés, les auteurs de [Che+07] proposent des conditions d'analyse de stabilité pour des systèmes à temps continu par des fonctions de Lyapunov qui sont homogènes autant dans le vecteur d'état que dans le vecteur des paramètres. Le cas à temps discret est le sujet des travaux de [DB01], où les auteurs étendent les résultats trouvés en [OBG99] aussi en utilisant des fonctions de Lyapunov dépendant des paramètres et des variables faibles. Dans [OP08], les auteurs proposent une nouvelle description de la variation paramétrique comme une fonction des valeurs des paramètres. Une fonction de Lyapunov dépendante des paramètres est utilisée pour dériver des conditions LMI. Dans [OP09], les travaux précédents sont étendus à une représentation plus complexe décrivant la relation entre le taux de variation des paramètres et la valeur des paramètres. Des conditions d'analyse sont obtenues par des fonctions de Lyapunov dépendant des paramètres.

Dans le cas des paramètres variants dans le temps avec des taux de variation arbitraires, [Che+02; Che+03a] abordent le problème d'analyse des systèmes incertains à temps continu en utilisant des fonctions de Lyapunov polynomiales homogènes dans le vecteur d'état et indépendantes des paramètres. Des conditions suffisantes pour la stabilité sont proposées, et dans certains cas, ces conditions sont prouvées comme étant aussi nécessaires.

Le choix de représentation d'un système physique doit être suffisamment complète pour proposer une bonne approximation du comportement entrée-sortie de ce système. La modélisation mathématique standard peut décrire des sorties qui sont des fonctions des entrées dans des instants précédents et des états internes, étant absolument causale. Néanmoins, plusieurs systèmes réels présentent un comportement non-causal provoqué, par exemple, par les étincelles dans les circuits électriques et les impulsions dans des systèmes robotiques [MG89]. Par ailleurs, les systèmes à chaîne cinématique fermée présentent des contraintes algébriques qui ne peuvent pas être décrites sous la modélisation mathématique standard. Ces limitations sont comblées par l'utilisation de l'*approche descripteur* qui peut exprimer un comportement non-causal et des contraintes algébriques. Dans la littérature, les systèmes descripteurs peuvent être référés comme des systèmes singuliers et systèmes dégénérés, entre autres appellations. Cette représentation est assez nouvelle, datant des années 70.

Étant donnée que les systèmes descripteurs sont apparus plus tard dans la littérature, des efforts sont mis en place pour étendre les techniques utilisées dans l'analyse et la commande des systèmes standard vers le cas des systèmes descripteurs. Cette extension doit prendre en compte que la versatilité trouvée dans le formalisme descripteur est suivie d'une complexité croissante. Par exemple, l'existence et l'unicité des solutions sont garanties pour un système linéaire standard, mais pas pour un système descripteur. Ainsi, une loi de commande conçue pour un système descripteur doit non seulement maintenir la stabilité de la boucle fermée, mais aussi assurer que plusieurs autres propriétés du système se conservent. Ces propriétés sont présentées et discutées en profondeur dans la thèse.

Une extension naturelle de la classe des systèmes descripteurs est la fusion avec le formalisme incertain. La classe des *systèmes descripteurs incertains* peut à la fois représenter des incertitudes du modèle, du comportement non-causal et des contraintes algébriques, ce qui est bien au delà de ce qu'un système dynamique standard peut décrire. Cela veut aussi dire qu'une analyse plus complexe des systèmes descripteurs incertains est requise, et en effet cela s'agit d'un domaine de recherche ouvert. De même, la littérature dédiée aux systèmes linéaires descripteurs à temps invariant est bien plus vaste que celle adressant les systèmes descripteurs incertains.

Des travaux dans la littérature traitent les problématiques associées à l'analyse et la commande des systèmes descripteurs en utilisant des fonctions de Lyapunov de différents types, bien comme de diverses techniques de convexification. Une petite synthèse de la recherche faite dans ce domaine se retrouve dans la suite.

Par rapport à la classe des systèmes descripteurs incertains ayant des *paramètres*

invariants dans le temps, les travaux dans [Fan02] fournissent des conditions d'admissibilité autant pour des systèmes à temps continu qu'à temps discret. Les conditions contiennent des inégalités non-strictes bornées par des coefficients obtenus de la majoration des polynômes semi-définis positifs. L'article [KF03] propose une étude de l'admissibilisation des systèmes descripteurs incertains à temps continu et à temps discret par des fonctions de Lyapunov quadratiques menant à des conditions d'inégalité non-strictes. Dans les travaux de [GCS03], la D-admissibilité des systèmes à temps continu et à temps discret est étudiée en utilisant deux fonctions de Lyapunov quadratiques: une indépendante et l'autre dépendante des paramètres. Les conditions obtenues sont aussi des inégalités matricielles non-strictes. Les travaux en [SF05] proposent des inégalités strictes comme des conditions pour l'analyse de stabilité robuste des systèmes descripteurs incertains à temps continu dépendant d'un seul paramètre. Des fonctions de Lyapunov quadratiques dans le vecteur d'état et polynomiales dans le vecteur de paramètres sont utilisés. En [YBC08], des conditions pour l'admissibilité, la D-admissibilité et les normes H_2 et H_∞ sont proposées pour les systèmes descripteurs incertains à temps continu en utilisant une fonction de Lyapunov dépendant des paramètres et des variables faibles.

Pour les systèmes descripteurs incertains ayant des *paramètres variants dans le temps* avec des taux de variation bornés, les travaux en [Bar11b] proposent des conditions d'analyse d'admissibilité pour des systèmes à temps continu par des inégalités strictes issues de l'utilisation des fonctions de Lyapunov dépendant des paramètres et des variables faibles. Dans l'article [Bar11a], l'auteur traite le cas à temps discret avec des paramètres possiblement variant dans le temps. Dans [BSC12], l'admissibilité des systèmes incertains à temps discret est évaluée par l'utilisation des fonctions de Lyapunov quadratiques dans le vecteur d'état et affines ou quadratiques dans le vecteur des paramètres. En [BSC13], les mêmes auteurs se dirigent vers le cas à temps continu en proposant l'analyse d'admissibilité et de performance H_∞ par le biais de fonctions de Lyapunov du même type qu'auparavant.

Des problématiques ouvertes et inexplorées peuvent être retrouvées dans la littérature. D'abord, les techniques proposées pour l'analyse d'admissibilité des systèmes incertains sont nécessaires et suffisantes dans peu de cas, étant seulement suffisantes pour la plupart des systèmes. Cette source de conservatisme peut être adressée par l'utilisation de classes de fonctions de Lyapunov universelles. Deuxièmement, on note que de nombreux outils et techniques originalement destinés pour le cas des systèmes incertains standard ont été transposés pour le contexte des systèmes descripteurs incertains. Toutefois, ce travail n'est pas encore terminé, et, en effet, l'utilisation des fonctions de Lyapunov polynomiales de degré arbitraire dans le vecteur d'état n'a pas encore été proposée pour l'analyse des systèmes descripteurs incertains. Troisièmement, les conditions d'admissibilité proposées dans la littérature sont souvent non-convexes et demandent des techniques de convexification qui peuvent apporter du conservatisme dans les solutions.

Cette thèse est une compilation des efforts placés dans les problèmes mentionnés et propose l'extension de l'utilisation des fonctions de Lyapunov polynomiales homogènes dans le cadre des systèmes descripteurs incertains. Ces extensions ont donné lieu à plusieurs contributions originales et ont fait l'objet de deux publications en conférences internationales de très haut niveau et deux soumissions en cours en revue. Ce manuscrit est structuré comme suit:

- *Chapitre 1*: Les concepts de base et les outils mathématiques utilisés dans les chapitres suivantes de la thèse y figurent. Dans ce chapitre, la formulation mathématique de plusieurs termes évoqués dans cette introduction est présentée.
- *Chapitre 2*: Une étude d'analyse d'admissibilité des systèmes descripteurs incertains à temps discret est proposée. Nous présentons des conditions nécessaires et suffisantes pour l'analyse d'admissibilité des systèmes descripteurs à temps variant. De ces nouvelles conditions contenant des variables faibles variant dans le temps, nous obtenons des conditions suffisantes et numériquement tractables pour l'analyse d'admissibilité des systèmes descripteurs incertains polytopiques ayant des paramètres avec des taux de variation bornés.
- *Chapitre 3*: L'analyse d'admissibilité des systèmes descripteurs incertains à temps continu ayant des paramètres variants dans le temps y est abordée. Cette analyse est produite par la pionnière utilisation des fonctions de Lyapunov homogènes dans le cadre des systèmes incertains descripteurs. Une fonction de Lyapunov homogène et indépendante des paramètres est proposée pour les systèmes ayant des paramètres variant dans le temps avec des taux de variation arbitraires.
- *Chapitre 4*: Des fonctions de Lyapunov homogènes dépendant des paramètres sont utilisées pour l'analyse d'admissibilité des systèmes descripteurs incertains à temps continu ayant des paramètres variants dans le temps avec des taux de variation bornés. Cela étend l'étude du chapitre précédent à un contexte plus général. Des dépendances de degré 1 et de degré quelconque sont étudiées et fournissent des conditions via des techniques de convexification différentes.
- *Chapitre 5*: La conclusion des travaux réalisés le long de la thèse et des perspectives des lignes de recherche qui suivent à cette investigation y sont proposées.

LISTE DES PUBLICATIONS ISSUES DE LA THÈSE

Cette thèse a mené à la publication des travaux suivants :

- dos Santos Paulino, Ana Carolina and Gabriela Iuliana Bara. "Homogeneous polynomial Lyapunov functions for the admissibility analysis of uncertain descriptor systems". Dans: Proceeding of the 56th IEEE Conference on Decision and Control, Melbourne, Australie, pp. 3187–3193.

- dos Santos Paulino, Ana Carolina and Gabriela Iuliana Bara. *“New LMI conditions for admissibility analysis of time-varying descriptor systems”*. Dans: Proceeding of the 20th IFAC World Congress, Toulouse, France 50.1, pp. 15477–15482.

Les travaux suivants sont en cours de soumission en revue :

- dos Santos Paulino, Ana Carolina and Gabriela Iuliana Bara. *“Polytopic parameter-dependent homogeneous polynomial Lyapunov functions for the analysis of uncertain descriptor systems”*.
- dos Santos Paulino, Ana Carolina and Gabriela Iuliana Bara. *“Robust admissibility of time-varying polytopic descriptor systems via parameter-dependent homogeneous polynomial Lyapunov functions”*.

Introduction

The understanding and mastering of the many physical systems that surround us often take a mathematical form. The theory of dynamical systems has been developed for centuries so far and has enabled the abstract modeling of concrete systems through observations, measurements and validation. However, this translation of the real world into a mathematical formalism is subject to how precisely we describe it. Evidently, measurement errors and inaccuracy might lead to a false model that cannot offer a trustworthy prediction of a system's behavior. Nevertheless, a refined description of the reality is a challenging task, sometimes being overwhelmingly complex and unnecessary for an envisaged application. For instance, fine precision might not seem to be a significant issue in school experiments, such as predicting the arrival time of a falling object, but for aerospace and medical fields, errors or unpredicted events can lead to irrecoverable losses [Gar03; Has+08]. Therefore, there exists a trade-off between accuracy and simplicity of the mathematical model of a system, and this trade-off must be tuned according to the context and application.

The framework of *uncertain systems* seems to give enough precision under affordable complexity for a variety of applications in aeronautics, robotics and industrial fields, to cite a few. Uncertain systems are said to be situated between linear and non-linear systems because they consist of a parameterized family of linear systems. The parameters might be time-varying resulting in time-varying dynamics. The compact representation of uncertain systems is very convenient, enabling not only the study of stability of the whole family of systems but also the synthesis of controllers that will keep this family well-behaved regardless of the parameters' variations. Although the uncertain formalism is a powerful and multi-purpose representation, its use may lead to challenges in the analysis that are eventually traded by a certain level of conservativeness in the numerical results. One may not be able to certify the stability an uncertain system using a quadratic Lyapunov function even if the given system is stable. This happens because the class of quadratic Lyapunov functions is not universal for the class of uncertain systems. The universality property of a class of Lyapunov functions consists in the equivalence between stability of a system and existence of a Lyapunov function within this class that certifies its stability. Another difficulty presented by this broad formalism is the space search. Given that the parameters of an uncertain system are able to vary in the real set (R), there is an infinite amount of tests to be performed in order to ensure that every realization of an uncertain system is stable. Because of that, convexification techniques are employed on the numerical resolution of the stability problem, often increasing the degree of conservatism of the

evaluation. Indeed, many attempts of progressively reducing the conservatism of the analysis of uncertain systems have been made, but this is still an open field of work.

In the literature, different techniques have been used to approach the stability analysis and control synthesis problems for uncertain systems. Many of these techniques were propelled by the aforementioned reduction in conservatism, and below, they are classified by the type of systems they address.

For uncertain systems subject to *time-invariant* parameters, the work of [OBG99] presents conditions for the stability analysis of discrete-time uncertain systems by using parameter-independent and parameter-dependent Lyapunov functions with slack variables. This became the basis for several of the following works that also employ slack variables in linear matrix inequality (LMI) conditions. The work of [Pea+00] proposes conditions for robust D-stability analysis of continuous and discrete-time systems with polytopic uncertainties by employing a parameter-dependent polytopic Lyapunov function along with constant slack variables. In the work of [RP01], conditions for the stability analysis of discrete-time uncertain systems subject to time-invariant parameters are evaluated by means of the existence of a parameter-dependent polytopic Lyapunov function. The derived conditions are bounded by scalars obtained from the maximization of positive-semidefinite polynomials. In [RP02], the authors extend the previous results on discrete-time uncertain systems to the continuous-time case. In [Che+03b], a Lyapunov function that is quadratic in the state vector and homogeneous in the parameter vector is proposed for the stability analysis of the continuous-time case with the possibility of extension to the discrete-time case.

For uncertain systems subject to *time-varying* parameters with finite rates of variation, the work [Che+07] proposes stability analysis conditions for the continuous-time case by means of Lyapunov functions that are homogeneously dependent both on the state and on the parameter vectors. The discrete-time case is addressed in [DB01], where the authors extend the results of [OBG99] also using parameter-dependent polytopic Lyapunov functions and slack variables. In [OP08], the authors propose a novel way to describe parameters' rates of variation as a function of the actual values of parameters and use a parameter-dependent polytopic Lyapunov function to derive LMI conditions. In [OP09], the previous work is extended to a more complex representation of the relationship between the parameter's values and their rates of variation and stability analysis conditions are obtained through parameter-dependent polytopic Lyapunov functions.

When the time-varying parameters are subject to unbounded rates of variation, [Che+02; Che+03a] address the problem of stability analysis of continuous-time uncertain systems by using Lyapunov functions that are parameter-independent and homogeneous polynomial in the state vector, deriving conditions that are sufficient, but in some limited cases, also proven to be necessary.

The chosen representation of a physical system must be comprehensive enough to describe a good approximation of the output behavior of a real plant. The massively standard mathematical modeling can provide outputs based on previous inputs and

inner states, being inherently causal. Yet, many systems that surround us present non-causal behavior, such as sparks in an electrical circuit and impulses in robotic systems [MG89]. Furthermore, some systems, such as closed kinetic chain robots, present algebraic constraints that cannot be represented in a standard state-space system. Fortunately, non-causal behavior and algebraic constraints are phenomena that can be depicted through the *descriptor approach*, that in the literature can be named as, for instance, generalized state space systems, semistate systems, degenerate systems, and so on. This broader representation is relatively new, being firstly studied in the 70s.

Given that descriptor systems have been subject of later interest in the literature, there exists an effort in extending techniques used in the analysis and control of standard state-space systems to the case of descriptor systems. This extension must take into account that the versatility found in the descriptor formalism is followed by a more complex analysis. For instance, existence and unicity of solutions are guaranteed for a linear state-space system but not for a descriptor system. Therefore, a control law conceived for a descriptor system must not only provide stability of the closed-loop, but also ensure that a set of other system properties are maintained. These properties are presented in the following chapters of the present thesis.

A natural extension to the class of descriptor systems is the fusion with the uncertain framework. This last class of *uncertain descriptor systems* can simultaneously represent uncertainties in the model, impulsive behavior and algebraic constraints, that is far beyond what can be depicted by standard dynamic systems. This also means that uncertain descriptor systems require a more complex analysis and are an open field of research. Indeed, there is vaster literature dealing with linear time-invariant descriptor systems than with uncertain descriptor systems.

Many works in the literature have addressed the analysis and control of uncertain descriptor systems. To obtain mathematical conditions for such class of systems, Lyapunov functions of different types have been employed, as well as different convexification techniques. Below, there is a non-exhausting list of previous works related to the field.

Concerning the class of uncertain descriptor systems subject to time-invariant parameters, the work [Fan02] provides admissibility conditions for both continuous and discrete-time cases using parameter-dependent polytopic Lyapunov functions. These conditions are given by nonstrict inequalities that are bounded by coefficients coming from the maximization of positive-semidefinite polynomials. The work [KF03] proposes a study on the admissibilization of continuous-time and discrete-time uncertain descriptor systems using a quadratic Lyapunov function to derive nonstrict inequality conditions. The work [GCS03] studies the D-admissibility of continuous and discrete-time systems using a quadratic and a parameter-dependent polytopic Lyapunov functions, also providing nonstrict inequalities as evaluation conditions. The work [SF05] proposes strict inequalities as conditions for the robust stability analysis of continuous-time uncertain descriptor systems with one parameter by employing

Lyapunov functions that are quadratically dependent on the state vector and polynomially dependent on the parameter vector. In the work [YBC08], conditions for the admissibility, D-admissibility and H_∞ and H_2 norms are proposed for continuous-time uncertain descriptor systems using a parameter-dependent Lyapunov function and slack variables.

For uncertain descriptor systems with time-varying parameters subject to finite rates of variation, the work [Bar11b] proposes admissibility analysis conditions for continuous-time uncertain descriptor systems through strict inequalities by means of parameter-dependent Lyapunov functions and slack variables. In the work [Bar11a], the discrete-time case with possibly time-varying parameters is addressed. In the work [BSC12], the admissibility of discrete-time uncertain descriptor systems is evaluated through the use of Lyapunov functions that are quadratic in the state vector and affine or quadratic in the parameter vector. In [BSC13], the authors proceed to the admissibility and H_∞ performance analyses of continuous-time uncertain descriptor systems also with Lyapunov functions that are quadratic in the state vector and affine or quadratic in the parameter vector.

In the cited works, some open problems can be found. First, the proposed approaches for the admissibility analysis of uncertain descriptor systems are necessary and sufficient for restricted cases, being only sufficient for the vast majority of systems. This source of conservatism can be tackled by the use of classes of Lyapunov functions that are guaranteed to provide necessary and sufficient conditions, and there is still much work to be done in this investigation. Second, it is observed that many techniques and tools that are employed in standard uncertain systems have been transposed to the case of uncertain descriptor systems. However, this transposition is still in progress, and the study of Lyapunov functions that are polynomial with arbitrary degree on the state vector has not been performed for the uncertain descriptor case. Third, the stability/admissibility conditions obtained from many of the Lyapunov functions proposed in the literature are not convex, demanding convexification techniques that may bring conservatism to the solutions.

This thesis is a compilation of the efforts placed over the aforementioned problems and aims to extend the homogeneous polynomial Lyapunov function theory proposed for classical uncertain systems to the uncertain descriptor system framework. This document is structured as follows:

- *Chapter 1*: Base concepts and mathematical tools that are used in the following parts of this thesis are reunited. In this chapter, a mathematical formulation for the many concepts evoked in this introduction is presented.
- *Chapter 2*: Admissibility analysis of discrete-time uncertain descriptor systems is studied. We propose necessary and sufficient admissibility criteria for time-varying descriptor systems. Then, with this novel criteria containing time-varying

slack variables, we obtain numerically tractable sufficient conditions for the admissibility analysis of polytopic parameter-dependent uncertain descriptor systems subject to parameters with bounded rates of variation.

- *Chapter 3*: Admissibility analysis of continuous-time uncertain descriptor systems subject to time-varying parameters is addressed. This analysis is performed by the novel use of parameter-independent homogeneous polynomial Lyapunov functions in the context of uncertain descriptor systems having parameters with arbitrary velocities.
- *Chapter 4*: Parameter-dependent homogeneous polynomial Lyapunov functions are used for the admissibility analysis of continuous-time uncertain systems subject to time-varying parameters with bounded rates of variation. This extends the previous studies to a more general case. Dependences of degree 1 and of arbitrary degree on the parameter vector are explored and lead to conditions that are obtained by different convexification techniques.
- *Chapter 5*: Conclusions of the work and topics of further analysis are proposed.

Finally, this thesis led to the publication of the following works:

- dos Santos Paulino, Ana Carolina and Gabriela Iuliana Bara. “Homogeneous polynomial Lyapunov functions for the admissibility analysis of uncertain descriptor systems”. In: Proceeding of the 56th IEEE Conference on Decision and Control, Melbourne, Australia, pp. 3187–3193.
- dos Santos Paulino, Ana Carolina and Gabriela Iuliana Bara. “New LMI conditions for admissibility analysis of time-varying descriptor systems”. In: Proceeding of the 20th IFAC World Congress, Toulouse, France 50.1, pp. 15477–15482.

The ensuing works have been submitted for publication:

- dos Santos Paulino, Ana Carolina and Gabriela Iuliana Bara. “Polytopic parameter-dependent homogeneous polynomial Lyapunov functions for the analysis of uncertain descriptor systems”.
- dos Santos Paulino, Ana Carolina and Gabriela Iuliana Bara. “Robust admissibility of time-varying polytopic descriptor systems via parameter-dependent homogeneous polynomial Lyapunov functions”.

Chapter 1

Theoretical background

In this chapter, mathematical tools that are fundamental for the understanding of the ensuing parts of this thesis are presented. We are mainly interested in the analysis of *uncertain descriptor systems*, that reunite concepts from both *descriptor systems* and *uncertain systems*. In the following, we present the formalism of the aforementioned systems, their uses, properties, and techniques in stability/admissibility analysis that can be found in the literature.

Descriptor systems are a powerful framework for dynamic systems because they not only describe the time evolution of the states but they also allow the insertion of algebraic constraints between the state variables and the representation of impulsive behavior in a model. Several names may refer to descriptor systems such as *behavioral models*, *implicit systems*, *singular systems*, *semistate representation*, *generalized state-space systems*, *differential-algebraic systems*, *degenerate systems*, *constrained systems* [Dai89; Lew86; Ger04; CKM11].

The use of the descriptor representation is useful for various applications. In robotics, parallel driven cable robots, multi-legged robots, tensegrity structures, and closed kinematic chain robots present rigid constraints between their actuators or joints [HLB14; CH08; MG89]. In electronics, frequently used components, such as capacitors and inductors, present impulsive behavior by releasing sparks due to the signal change in circuits. In chemistry and physics, conservation of physical laws, such as conservation of energy and mass, must hold for the mathematical models and can be expressed through algebraic constraints. The class of descriptor systems has also been used in other applications, such as catastrophic behavior, neurology, aircraft dynamics, neutral delay systems, economics [LA77] and demography, as explicated in [Lew86].

A descriptor system can be represented in a state-space representation by the quadruplet (E, A, B, C) in which the elements of the triplet (A, B, C) have the usual meaning found for the standard systems, namely dynamic matrix, input matrix and output matrix, respectively. The innovation is found in the derivative matrix E that multiplies the vector of state derivatives, in the continuous-time case, or the time-shifted state vector, in the discrete-time case.

A descriptor system in which matrices E , A , B and C are time-invariant is called a *linear time-invariant (LTI) descriptor system*. In case these matrices present an explicit

time dependence $E(t)$, $A(t)$, $B(t)$ and $C(t)$, they describe the so-called *time-dependent descriptor system*, here also referred as linear time-varying (LTV) systems. If this time dependence can be parameterized by a vector of parameters $w \in R^m$, matrices $E(w)$, $A(w)$, $B(w)$ and $C(w)$ refer to a *parameter-dependent linear system* here also called a linear parameter varying (LPV) system. The relationship between the dynamic matrices of LTI, LPV and LTV systems is portrayed in Figure 1.1. The same reasoning is applied for the other matrices of the models.

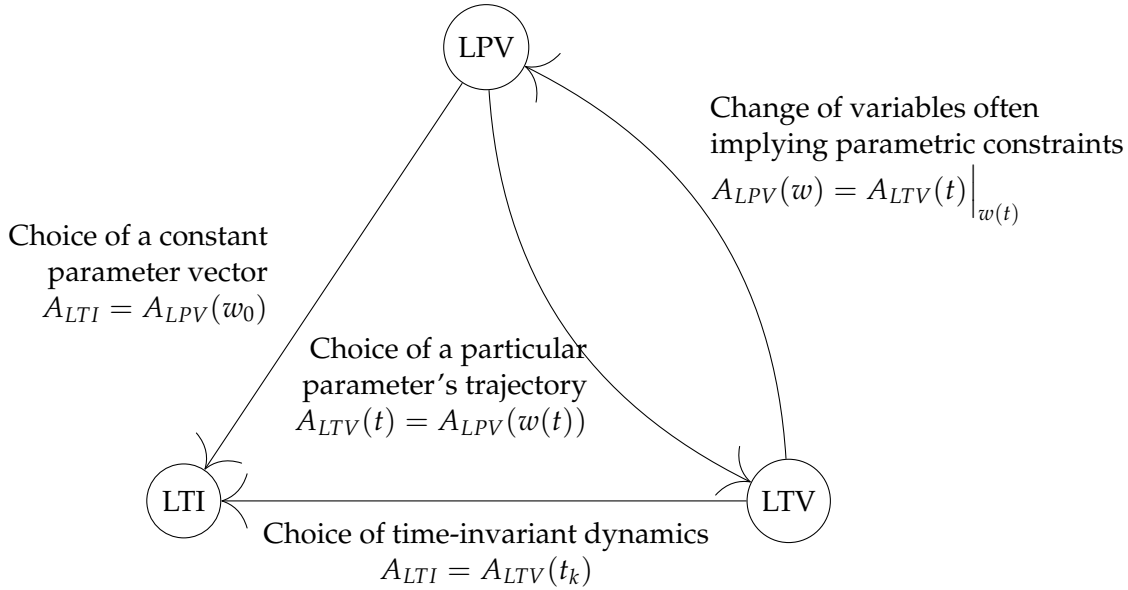

FIGURE 1.1: Relationship between linear time-invariant (LTI), linear parameter-varying (LPV) and linear time-varying (LTV) systems

In this thesis, we are mostly interested in the class of parameter-dependent linear descriptor systems with possibly time-varying parameters. Because of that, the chapter is organized as follows: in the first section, we present concepts related to the simplest version of descriptor systems, *i.e.* LTI descriptor systems. Then, in the second section, we recall the theory of standard parameter-dependent systems. Finally, in the third section, we group the two precedent ones in our subject of interest, the parameter-dependent descriptor systems.

1.1 LTI descriptor systems

The versatility found in descriptor systems, when compared to standard ones, is due to the presence of a derivative matrix, here denoted as E , that multiplies the derivative vector, as follows:

Definition 1.1.1 (Descriptor system): A descriptor system is given by

$$E\delta[X] = AX + Bu \quad (1.1a)$$

$$y = CX, \quad (1.1b)$$

where $X \in \mathbb{R}^{(n+n_\xi)}$ is the system state vector, δ is a derivative operator for the continuous-time case, and a time-shift operator for the discrete-time case, $A \in \mathbb{R}^{(n+n_\xi) \times (n+n_\xi)}$ is the associated dynamic matrix, $B \in \mathbb{R}^{(n+n_\xi) \times g}$ is the input matrix, $C \in \mathbb{R}^{h \times (n+n_\xi)}$ is the output matrix, $E \in \mathbb{R}^{(n+n_\xi) \times (n+n_\xi)}$ is the derivative matrix where $\text{rank}(E) = n$, and vectors $u \in \mathbb{R}^g$ and $y \in \mathbb{R}^h$ are the input and the output, respectively.

Remark 1.1.2 (Dimensions' notations). Dimensions n and n_ξ have been introduced in order to clearly emphasize the dimensions of the dynamic and algebraic parts of the system state vector X . These two parts can be explicitly retrieved through a transformation in the system state vector X given by the Singular value decomposition normal form. This manipulation will be detailed in the ensuing section 1.1.2.

Remark 1.1.3 (Continuous-time and discrete-time representations). Time-dependence is here omitted for the sake of unified notation. If the descriptor system (1.1) is continuous-time, we have

$$E\dot{X}(t) = AX(t), \quad (1.2)$$

and if it is discrete-time, we have

$$EX(k+1) = AX(k). \quad (1.3)$$

We note that the descriptor framework is a generalization of the standard state-space representation. For describing a standard-space system, one can choose to use the formalism in (1.1) with a full-rank E matrix. Please note that for $E = I_{n+n_\xi}$ we obtain a standard dynamic system.

1.1.1 Examples

To illustrate the formalism of descriptor systems, some examples based on the aforementioned applications follow:

Example 1: A simple circuit network [Dai89]

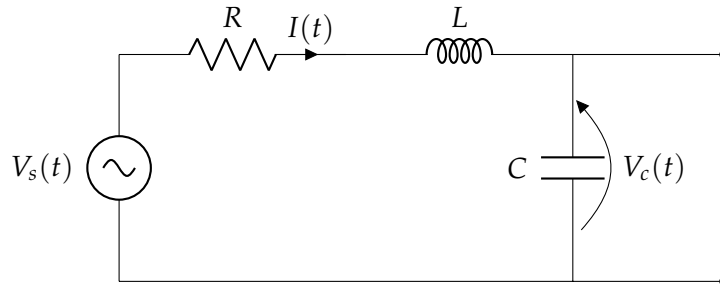

FIGURE 1.2: A RLC circuit network

Consider the classic resistor-inductor-capacitor (RLC) serial circuit network in Figure 1.2. Its dynamical equation is given by

$$V_s(t) - V_R(t) - V_L(t) - V_C(t) = 0, \quad (1.4)$$

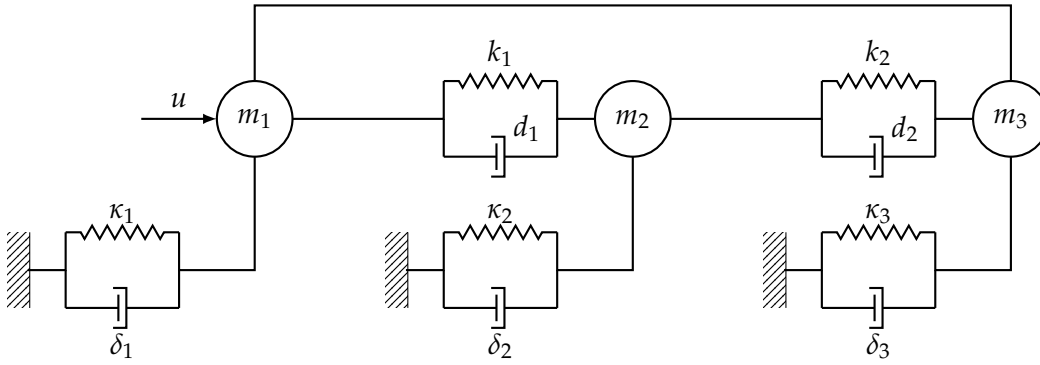

FIGURE 1.3: A mechanical system

and the dynamics of the components are characterized as

$$V_R(t) = RI(t), \quad (1.5)$$

$$V_L(t) = L \frac{d}{dt} I(t), \quad (1.6)$$

$$V_C(t) = \frac{1}{C} \int_0^t I(\tau) d\tau. \quad (1.7)$$

Choosing the state vector $X(t) = [I(t) \ V_R(t) \ V_L(t) \ V_C(t)]^T$, equations (1.4) to (1.7) are stacked in the following descriptor representation:

$$\begin{bmatrix} 0 & 0 & 0 & 0 \\ 0 & 0 & 0 & 0 \\ L & 0 & 0 & 0 \\ 0 & 0 & 0 & C \end{bmatrix} \begin{bmatrix} \dot{I}(t) \\ \dot{V}_R(t) \\ \dot{V}_L(t) \\ \dot{V}_C(t) \end{bmatrix} = \begin{bmatrix} 0 & 1 & 1 & 1 \\ R & -1 & 0 & 0 \\ 0 & 0 & 1 & 0 \\ 1 & 0 & 0 & 0 \end{bmatrix} \cdot \begin{bmatrix} I(t) \\ V_R(t) \\ V_L(t) \\ V_C(t) \end{bmatrix} + \begin{bmatrix} -1 \\ 0 \\ 0 \\ 0 \end{bmatrix} \cdot V_s(t). \quad (1.8)$$

The output is given by $y(t) = [0 \ 0 \ 0 \ 1] X(t)$.

The formulation of the dynamics in (1.8) shows the use of the descriptor state-space representation that employs a rank-deficient matrix E . Note that relation (1.4) describing the electrical circuit Kirchhoff law appears as an algebraic constraint in the descriptor formulation (1.8). Even if for this particular system an equivalent standard formulation can be obtained, for which the matrix E has full rank, it is important to recall that, in general, *if algebraic constraints are no longer explicit, numerical methods might deviate from the constraints and lead to physically meaningless results [CKM11]*.

Example 2: A mechanical system [BW18]

Consider the constrained damped mass-spring system in Figure (1.3). The movement is associated with the following equations:

$$M\dot{v}(t) = Kp(t) + Dv(t) - G^T\lambda(t) + Bu(t) \quad (1.9)$$

$$\dot{p}(t) = v(t) \quad (1.10)$$

$$0 = Gp(t), \quad (1.11)$$

in which the mass matrix is given as $M = B\text{diag}(m_1, m_2, m_3)$, the damping matrix is

$$K = \begin{bmatrix} -k_1 - \kappa_1 & k_1 & 0 \\ k_1 & -k_1 - k_2 - \kappa_2 & k_2 \\ 0 & k_2 & -k_2 - \kappa_3 \end{bmatrix}, \text{ the stiffness matrix is}$$

$$D = \begin{bmatrix} -d_1 - \delta_1 & d_1 & 0 \\ d_1 & -d_1 - d_2 - \delta_2 & d_2 \\ 0 & d_2 & -d_2 - \delta_3 \end{bmatrix}, \text{ the constraint matrix is } G = \begin{bmatrix} 1 & 0 & -1 \end{bmatrix},$$

and the input matrix is $B = \begin{bmatrix} 1 \\ 0 \\ 0 \end{bmatrix}$. Grouping the formulation in the descriptor form,

one obtains:

$$\begin{bmatrix} 0 & M & 0 \\ I_3 & 0 & 0 \\ 0 & 0 & 0 \end{bmatrix} \begin{bmatrix} \dot{p}(t) \\ \dot{v}(t) \\ \dot{\lambda}(t) \end{bmatrix} = \begin{bmatrix} K & D & G^T \\ 0 & I_3 & 0 \\ G & 0 & 0 \end{bmatrix} \begin{bmatrix} p(t) \\ v(t) \\ \lambda(t) \end{bmatrix} + \begin{bmatrix} B \\ 0 \\ 0 \end{bmatrix} u(t). \quad (1.12)$$

The representation (1.12) presents not only the possibility of explicitly describing algebraic constraints (1.11), but a further study shows that this system also presents impulsive behavior, as will be discussed in the following.

1.1.2 The singular value decomposition (SVD) normal form

System (1.1) can be subject to a transformation that separates the state vector X into a dynamic part and an algebraic part. Then, as the notation suggests, the system presents distinctly dynamical equations concatenated with algebraic relations. This is known as the singular value decomposition (SVD) normal form. The transformation that leads to this form is non-unique, and can be obtained through SVD over the derivative matrix E and rank-decomposition. Below, it is shown in what the SVD form consists.

Lemma 1.1.4 (SVD normal decomposition): There exist invertible matrices $S \in \mathbb{R}^{(n+n_\xi) \times (n+n_\xi)}$ and $T \in \mathbb{R}^{(n+n_\xi) \times (n+n_\xi)}$ such that $SET = B\text{diag}(I_n, 0_{n_\xi})$. Then, considering the change of variables $\bar{X} = T^{-1}X$, the SVD normal decomposition of system (1.1) is

$$\begin{bmatrix} I_n & 0 \\ 0 & 0_{n_\xi} \end{bmatrix} \delta[\bar{X}] = \begin{bmatrix} A_{11} & A_{12} \\ A_{21} & A_{22} \end{bmatrix} \bar{X} + \begin{bmatrix} B_1 \\ B_2 \end{bmatrix} u, \quad (1.13)$$

$$y = \begin{bmatrix} C_1 & C_2 \end{bmatrix} \bar{X},$$

where $SAT = \begin{bmatrix} A_{11} & A_{12} \\ A_{21} & A_{22} \end{bmatrix}$, $SB = \begin{bmatrix} B_1 \\ B_2 \end{bmatrix}$ and $CT = \begin{bmatrix} C_1 & C_2 \end{bmatrix}$. Consider $\bar{X} = \begin{bmatrix} x \\ \xi \end{bmatrix}$. The matrixial equality (1.13) is equivalent to two sets of equations, one being dynamic and the other, algebraic:

$$\delta[x] = A_{11}x + A_{12}\xi + B_1u \quad (1.14a)$$

$$0^{n_\xi \times 1} = A_{21}x + A_{22}\xi + B_2u \quad (1.14b)$$

$$y = C_1x + C_2\xi. \quad (1.14c)$$

Remark 1.1.5 (Calculation through SVD and scaling). Consider the derivative matrix E . Given that $\text{rank}(E) = n$, E has n non-null eigenvalues. Therefore, calculating its SVD, we obtain $E = RUV$, where $R, V \in \mathbb{R}^{(n+n_\xi) \times (n+n_\xi)}$ are unitary matrices and $U \in \mathbb{R}^{(n+n_\xi) \times (n+n_\xi)}$ is a diagonal matrix with nonnegative entries. The matrix U is of form $U = B\text{diag}(u_1, u_2, \dots, u_n, 0_{n_\xi})$, in which u_i , $i = 1, \dots, n$ are not necessarily equal to 1. However, $U = B\text{diag}(u_1, u_2, \dots, u_n, I_{n_\xi}) \cdot B\text{diag}(I_n, 0_{n_\xi})$. With such manipulation, we obtain:

$$\begin{aligned} E &= RUV \\ &= R \begin{bmatrix} u_1 & & & \\ & \ddots & & \\ & & u_n & \\ & & & I_{n_\xi} \end{bmatrix} \cdot \begin{bmatrix} I_n & \\ & 0_{n_\xi} \end{bmatrix} V, \end{aligned} \quad (1.15)$$

and we can set $S = B\text{diag}(\frac{1}{u_1}, \frac{1}{u_2}, \dots, \frac{1}{u_n}, I_{n_\xi}) \cdot R^{-1}$, $\bar{E} = B\text{diag}(I_n, 0_{n_\xi})$ and $T = V^{-1}$.

Remark 1.1.6 (Rank decomposition). Suppose that the rank decomposition of the matrix E is $E = HJ$, with $H \in \mathbb{R}^{(n+n_\xi) \times n}$ and $J \in \mathbb{R}^{n \times (n+n_\xi)}$. One can expand this product by introducing a block-diagonal matrix $B\text{diag}(I_n, 0_{n_\xi})$ as follows:

$$E = \begin{bmatrix} H & H_k \end{bmatrix} \cdot \begin{bmatrix} I_n & \\ & 0_{n_\xi} \end{bmatrix} \begin{bmatrix} J \\ J_k \end{bmatrix}, \quad (1.16)$$

where $H_k = \text{Ker}(H^T) \in \mathbb{R}^{(n+n_\xi) \times n_\xi}$ and $J_k = \text{Ker}(J^T) \in \mathbb{R}^{n_\xi \times (n+n_\xi)}$. Please note that matrices $\begin{bmatrix} H & H_k \end{bmatrix}$ and $\begin{bmatrix} J \\ J_k \end{bmatrix}$ are full-rank.

In this case, $\bar{E} = B\text{diag}(I_n, 0_{n_\xi}) = SET$, in which $S = \begin{bmatrix} H & H_k \end{bmatrix}^{-1}$ and $T = \begin{bmatrix} J \\ J_k \end{bmatrix}^{-1}$.

1.1.3 Properties of descriptor systems

The versatility of the descriptor framework is not exempted of costs. Though this formalism can represent more phenomena than a standard state-space representation, existence and uniqueness of solutions for any initial conditions must be verified. This

is an indication that the problem has been well-posed, and it might give some insight about the pertinence of the modeling process. Furthermore, one needs to verify whether the system is stable and causal, and if not, act upon it by designing a suitable control law. Some properties of descriptor systems, and how to compute them, are given on the following.

Regularity

This property ensures the existence and uniqueness of solutions for a given descriptor system.

Definition 1.1.7 (Regularity): The descriptor system (1.1) is regular if $\det(\lambda E - A)$ is not identically zero, i.e. $\det(\lambda E - A) \neq 0$ for some $\lambda \in \mathbb{C}$.

Consider the application of the Laplace transform over the continuous-time version of the autonomous system (1.1) given by $E\dot{X}(t) = AX(t)$. We obtain:

$$E(s\mathbb{X}(s) - X(0)) = A\mathbb{X}(s), \quad (1.17)$$

where s is the Laplace variable, $\mathbb{X}(s) = \int_0^\infty e^{-st}X(t)dt$ and $X(0)$ is the initial condition of the generalized state vector. We have that $\mathbb{X}(s) = (sE - A)^{-1}EX(0)$, therefore, the existence of the inverse of the matrix $(sE - A)$ is necessary for $\mathbb{X}(s)$ to be defined for every $X(0)$.

Concerning the discrete-time version of the autonomous system (1.1), given as $EX(k+1) = AX(k)$, consider the application of the Z-transform:

$$Ez(\mathbb{X}(z) - X(0)) = A\mathbb{X}(z), \quad (1.18)$$

where z is the Z-transform variable, $\mathbb{X}(z) = \sum_{k=0}^{\infty} x[k]z^{-k}$ and $X(0)$ is the vector initial condition. We find $\mathbb{X}(z) = (zE - A)^{-1}zEX(0)$ and, as for the continuous-time case, the inverse of $(zE - A)$ must be well-defined for the computation of $X(z)$.

Therefore, for either continuous and discrete-time cases, we observe that the inverse of a matrix $\lambda E - A$ must exist for some λ . Therefore, *regularity* is mathematically given by $\det(\lambda E - A) \neq 0$.

Besides regularity, other properties are to be verified and ensured over a system, such as absence of impulsive modes and the stability of finite modes.

Absence of impulsive modes or causality

When a continuous-time descriptor system is *impulse-free*, its time-response does not contain impulses or derivatives of the input. Likewise, when a discrete-time descriptor system is *causal*, its response is free of Dirac impulses, and all of the current states can be calculated from past information of the states and the entries of the system. It is important to ascertain the impulsive behavior of a descriptor system

because impulses may lead to degradation in performance and damaging of system components [IT02].

Definition 1.1.8 (Absence of impulsive modes or causality): The descriptor system (1.1) is impulse-free (continuous-time systems) or causal (discrete-time systems) if $\deg(\det(\lambda E - A)) = \text{rank}(E)$.

The poles of a descriptor system are the λ solutions of the characteristic polynomial $\det(\lambda E - A)$. The finite solutions of this equation are the *finite modes*. There are at most $\text{rank}(E)$ finite modes in a descriptor system and the number of finite modes and *infinite modes* sum up to $n + n_\xi$. A system has no *impulsive modes* if the number of finite modes equals $\text{rank}(E)$.

Provided that a descriptor system is regular, there exists a similarity transformation that explicits the presence or absence of impulsive modes as presented in the following. The *canonical form* of a descriptor system is obtained through another similarity transformation that leads to a clear insight of the time response of a given descriptor system. Differently from the dynamic-algebraic separation in the SVD normal form, the canonical form, also known as Weierstrass canonical form and Kronecker's canonical form, divides a regular descriptor system into a fast and a slow subsystems. The fast subsystem contains the impulsive behavior, and the slow one presents the dynamics of a classical state-space system. The formulation of the given transformation is found below.

Lemma 1.1.9 (Canonical form): Consider the regular descriptor system (1.1). There exist invertible matrices $S \in \mathbb{R}^{(n+n_\xi) \times (n+n_\xi)}$ and $T \in \mathbb{R}^{(n+n_\xi) \times (n+n_\xi)}$ such that matrices $SET = B\text{diag}(I_{n_f}, \mathcal{N})$ and $SAT = B\text{diag}(J, I_{n_\infty})$. The matrix $\mathcal{N} \in \mathbb{R}^{n_\infty \times n_\infty}$ is nilpotent with index of nilpotency μ , meaning that $\mathcal{N}^k = 0_{n_\infty} \forall k \geq \mu$. The matrix $J \in \mathbb{R}^{n_f \times n_f}$ contains all the finite modes found in the characteristic polynomial $\det(\lambda E - A)$. Dimensions n_f and n_∞ indicate the sizes of the vectors of finite and infinite modes, such that the equality $n + n_\xi = n_f + n_\infty$ holds. With the change of variables

$\bar{X} = T^{-1}X = \begin{bmatrix} x_1 \\ x_2 \end{bmatrix}$, the canonical form of (1.1) is given by the equivalent forms:

$$\begin{cases} SET\delta[\bar{X}] = SAT\bar{X} + SBu \\ y = CT\bar{X} \end{cases} \Leftrightarrow \begin{cases} \begin{bmatrix} I_{n_f} & \\ & \mathcal{N} \end{bmatrix} \delta \begin{bmatrix} x_1 \\ x_2 \end{bmatrix} = \begin{bmatrix} J & \\ & I_{n_\infty} \end{bmatrix} \begin{bmatrix} x_1 \\ x_2 \end{bmatrix} + \begin{bmatrix} B_1 \\ B_2 \end{bmatrix} u \\ y = \begin{bmatrix} C_1 & C_2 \end{bmatrix} \begin{bmatrix} x_1 \\ x_2 \end{bmatrix} \end{cases}$$

The procedure for obtaining the canonical form is detailed in [Ger04] and evoked in several different works [Dai89; Dua10; BMS05; VD79].

We observe that the canonical form is given by the sets of equations below:

$$\delta[x_1] = Jx_1 + B_1u \quad (1.19a)$$

$$\mathcal{N}\delta[x_2] = x_2 + B_2u \quad (1.19b)$$

$$y = C_1x_1 + C_2x_2 \quad (1.19c)$$

Equation (1.19a) describes the slow subsystem, being defined by an ordinary differential equation. Its solution for the continuous-time case is given as

$$x_1(t) = e^{Jt}x_1(0) + \int_0^t e^{J(t-\tau)}B_1u(\tau)d\tau, \quad (1.20)$$

and for the discrete-time case, is given as

$$x_1(k) = J^kx_1(0) + \sum_{\tau=1}^k J^{k-\tau}B_1u(\tau-1). \quad (1.21)$$

For obtaining the solution x_2 of equation (1.19b), we use the properties of nilpotency of matrix \mathcal{N} . For the continuous-time case, we successively derive and multiply by \mathcal{N} equation (1.19b) for $\mu - 1$ times, obtaining:

$$\begin{aligned} \mathcal{N}\dot{x}_2 &= x_2 + B_2u \\ \mathcal{N}^2x_2^{(2)} &= \mathcal{N}\dot{x}_2 + \mathcal{N}B_2\dot{u} \\ &\dots \\ \mathcal{N}^\mu x_2^{(\mu)} &= \mathcal{N}^{\mu-1}x_2^{(\mu-1)} + \mathcal{N}^{\mu-1}B_2u^{(\mu-1)}. \end{aligned} \quad (1.22)$$

We recursively fetch the equations and recall that $\mathcal{N}^\mu = 0_{n_\infty}$ for obtaining the solution:

$$x_2(t) = - \sum_{i=1}^{\mu-1} \mathcal{N}^i B_2 u^{(i)}(t). \quad (1.23)$$

For the discrete-time case, we successively shift in time and multiply by \mathcal{N} the equation (1.19b), leading to:

$$\begin{aligned} \mathcal{N}x_2(k+1) &= x_2(k) + B_2u(k) \\ \mathcal{N}^2x_2(k+2) &= \mathcal{N}x_2(k+1) + \mathcal{N}B_2u(k+1) \\ &\dots \\ \mathcal{N}^\mu x_2(k+\mu) &= \mathcal{N}^{\mu-1}x_2(k+\mu-1) + \mathcal{N}^{\mu-1}B_2u(k+\mu-1), \end{aligned} \quad (1.24)$$

and analogously to the continuous-time case, we have:

$$x_2(k) = - \sum_{i=1}^{\mu-1} \mathcal{N}^i B_2 u(k+i). \quad (1.25)$$

We note that we may find impulses in (1.23) if the input function is less than $\mu - 1$ smooth derivatives, and that the behavior of (1.25) is clearly non-causal, because the output counts upon the values of $\mu - 1$ future inputs.

Furthermore, a *consistent initial condition* must be respected for continuous and discrete times, respectively:

$$x_2(0) = - \sum_{i=1}^{\mu-1} \mathcal{N}^i B_2 u^{(i)}(0^+), \quad (1.26)$$

$$x_2(0) = - \sum_{i=1}^{\mu-1} \mathcal{N}^i B_2 u(i). \quad (1.27)$$

If such conditions are not respected, impulses may be observed in the output.

Therefore, to avoid impulsive or non-causal behavior, the nilpotency index of matrix \mathcal{N} must be $\mu = 0$. We notice that if this happens, we have a special case of SVD normal form as in (1.13) where $\begin{bmatrix} A_{11} & A_{12} \\ A_{21} & A_{22} \end{bmatrix}$ is a diagonal matrix and $A_{22} = I_{n_\infty}$. Furthermore, n and n_ζ in (1.13) are respectively n_f and n_∞ .

Stability of finite modes

As for standard dynamic systems, stability is an important characteristic for descriptor systems. It is desirable that the time response of an autonomous descriptor system is such that the system leaves from an arbitrary initial configuration and arrives to the equilibrium states after a certain time. Without loss of generality, we consider in the following that the equilibrium point is the origin of the state space.

Definition 1.1.10 (Stability of finite modes): Among the finite modes, stability is ensured if asymptotic convergence towards zero of the associated states is satisfied.

Considering a LTI standard system, for the continuous-time case, stability means that poles must lay in the left side of the complex plan, and for the discrete-time case, poles must be inside the unit circle.

Admissibility

Definition 1.1.11 (Admissibility): The descriptor system (1.1) is *admissible* if it is regular, impulse-free and its finite modes are stable.

Admissibility is a property to be maintained, or ensured, through the process of conceiving a control law. In other words, it is envisaged to maintain the well-posedness of the representation while bringing all the impulsive modes and unstable poles to a finite and stable subset.

It is also important to stress that the existence of constraints and infinite modes do not necessarily impose the presence of impulsive modes. We recall that constraints can be embedded in a pure dynamic representation, the so-called equivalent standard form, and a standard form cannot represent non-causal/impulsive behavior.

Remark 1.1.12 (Admissibility of a system in the SVD normal form). *Consider the autonomous LTI descriptor system in SVD normal form (1.13) with $u = 0$. The invertibility of*

submatrix A_{22} ensures simultaneously regularity and absence of impulsive modes, while the stability of such system is evaluated by the equivalent standard form, that is obtained by implicitly embedding the constraints in a standard space-state form. Indeed, given that A_{22} is invertible and considering equation (1.14b), the algebraic vector ζ can be written as a function of the dynamic vector x as

$$\zeta = -A_{22}^{-1}A_{21}x. \quad (1.28)$$

Introducing (1.28) in equation (1.14a), one obtains the so-called equivalent standard form:

$$\dot{x} = (A_{11} - A_{12}A_{22}^{-1}A_{21})x. \quad (1.29)$$

The asymptotic stability of the equivalent standard form is equivalent to the admissibility of the descriptor system.

1.1.4 Admissibility analysis of descriptor systems

Lyapunov functions are massively used in the control field, and, likewise, they have been employed to derive conditions for the admissibility analysis of descriptor systems. It is known that, for standard LTI systems, stability conditions are equivalent to the existence of a Lyapunov function that is quadratic on the state vector. This fact also holds for descriptor systems and different results have been proposed in the literature for computing such Lyapunov functions.

A quadratic Lyapunov function candidate for descriptor systems has the following form

$$V(X) = X^T E^T P E X. \quad (1.30)$$

Conditions for the existence of such a Lyapunov function for the system (1.1) are derived below for the continuous-time and discrete-time cases.

Admissibility analysis of continuous-time descriptor systems

For the Lyapunov function candidate (1.30) to actually be a suitable Lyapunov function for the descriptor system (1.1), positive-definiteness of the function and negative-definiteness of its time-derivative are required, and the each of these conditions are here deployed for the continuous-time case.

- *Positive-definiteness of the Lyapunov function:* Given that the Lyapunov function of form (1.30) is quadratic with respect to the states, positive-definiteness is ensured once $E^T P E > 0$. However, we recall that E is not full-rank, rather imposing the non-strict inequality $E^T P E \geq 0$. Still, we note that the strict positivity of matrix P is sufficient but not necessary to provide the strict positivity of the scalar function (1.30). Nevertheless, the authors of [UI99] suggest that a relaxation in this condition would be of no gain.

- *Negative-definiteness of the time derivative of the Lyapunov function:* The time-derivative of the Lyapunov function candidate (1.30) is given as

$$\begin{aligned}\frac{d}{dt}V(X(t)) &= \dot{X}^T E^T P E X + X^T E^T P E \dot{X} \\ &= X^T (A^T P E + E^T P A) X.\end{aligned}\quad (1.31)$$

In the work of [Mas+97], we find a Lyapunov function candidate in the form

$$V(X) = X^T E^T \bar{P} X, \quad (1.32)$$

that corresponds to the choice $\bar{P} = PE$ in the Lyapunov function formulation (1.30).

This choice leads to the following set of conditions for the admissibility analysis of continuous-time descriptor systems:

$$E^T \bar{P} = \bar{P}^T E \geq 0, \quad (1.33)$$

$$A^T \bar{P} + \bar{P}^T A < 0. \quad (1.34)$$

These conditions present non-strict inequalities that are undesirable for the numerical implementation. In [UI99], we find that *"because of round-off errors in digital computation, the equality constraints are fragile and in usual not satisfied perfectly. In such cases, it is difficult to judge whether the constraint is really unsatisfied or satisfied but looks unsatisfied for computational reasons."* Such an inconvenient led to the research of Lyapunov function candidates providing strict inequalities.

In the works of [UI99; IT02; MKG03], not only is a Lyapunov function in the form of (1.32) used, but also an extra degree of freedom associated to the rank-deficiency of matrix E is exploited. Consider the *orthogonal complement* of E as being a matrix $E_0 \in \mathbb{R}^{(n+n_\xi) \times n_\xi}$ such that $E^T E_0 = 0^{(n+n_\xi) \times n_\xi}$.

This degree of freedom is introduced through different ways:

- In the works of [UI99; MKG03], a matrix $Q \in \mathbb{R}^{n_\xi \times n_\xi}$ is proposed, so that PE in (1.31) is replaced by $PE + E_0 Q E_0^T$ as:

$$\frac{d}{dt}V(X(t)) = X^T (A^T (PE + E_0 Q E_0^T) + (E^T P + E_0 Q^T E_0^T) A) X. \quad (1.35)$$

Therefore, the obtained admissibility conditions are given by the existence of $P > 0$ and Q such that $A^T (PE + E_0 Q E_0^T) + (E^T P + E_0 Q^T E_0^T) A < 0$ holds.

- In [IT02], a matrix $Q \in \mathbb{R}^{n_\xi \times (n+n_\xi)}$ is used when replacing PE in (1.31) with $PE + E_0 Q$. This leads to

$$\frac{d}{dt}V(X(t)) = X^T (A^T (PE + E_0 Q) + (E^T P + Q^T E_0^T) A) X. \quad (1.36)$$

Therefore, besides condition

$$P > 0, \quad (1.37)$$

it is required that

$$(A^T(PE + E_0Q) + (E^T P + Q^T E_0^T)A) < 0 \quad (1.38)$$

for ensuring the admissibility of system (1.1) by means of the Lyapunov function (1.30).

We notice that conditions (1.33) and (1.34) can be transformed respectively in (1.37) and (1.38) by the change of variables $\bar{P} = PE + E_0Q$, converting the nonstrict inequalities into strict inequalities. Also note that this same change of variables converts the Lyapunov function (1.32) into (1.30).

Remark 1.1.13 (Lyapunov functions for descriptor systems and the SVD normal form). Consider the Lyapunov function with the structure given in (1.30) proposed for the descriptor system in the SVD normal form given in (1.13) as $V(\bar{X}) = \bar{X}^T \bar{E}^T P \bar{E} \bar{X}$. Consider also a partition in the Lyapunov matrix $P = \begin{bmatrix} P_{11} & P_{12} \\ P_{21} & P_{22} \end{bmatrix}$. Replacing the values of \bar{E} and the partitioned P in the expression of the Lyapunov function, we obtain

$$V(X) = x^T P_{11} x. \quad (1.39)$$

We note, then, that only the dynamic part of the state vector appears.

Admissibility analysis of discrete-time descriptor systems

For the discrete-time case, the Lyapunov candidate found in the literature must also respect positive-definiteness, as well as negative-definiteness on its time rate of variation. The deployed conditions follow.

- *Positive-definiteness of the Lyapunov function:* Analogously to the continuous-time case, the Lyapunov function (1.30) is quadratic with respect to the states. Positive-definiteness is given, therefore, by the enforcement of the condition $E^T P E \geq 0$.
- *Negative-definiteness of the time rate of variation of the Lyapunov function:* The rate of variation of (1.30) is given by:

$$\begin{aligned} \Delta V(X(k)) &= V(X(k+1), k+1) - V(X(k), k) \\ &= X^T(k+1) E^T P E X(k+1) - X^T(k) E^T P E X(k). \end{aligned} \quad (1.40)$$

In the work of [HL99], the proposed conditions for the admissibility of a discrete-time uncertain system were given by the existence of a positive-definite matrix P that satisfies the conditions below:

$$A^T P A < E^T P E \quad (1.41)$$

$$E^T P E \geq 0. \quad (1.42)$$

The condition (1.42) is a nonstrict inequality that one would rather avoid for a numerical implementation. Later in [IT03; ZXS08; CD12], positive-definiteness of the Lyapunov function is enforced through the strict inequality condition $P > 0$. Furthermore, these works exploit the use of the extra degree of freedom due to the rank-deficiency of E in different ways:

- In the works of [ZXS08; CD12], a symmetric matrix $Q \in \mathbb{R}^{n_\xi \times n_\xi}$ in (1.40) is introduced, being multiplied to the right and to the left to the orthogonal complement of the derivative matrix:

$$\Delta V(X(k)) = X^T(k)(A^T(P - E_0QE_0^T)A - E^TPE)X(k), \quad (1.43)$$

leading to the condition $A^T(P - E_0QE_0^T)A - E^TPE < 0$;

- In the work of [IT03], a rectangular matrix $Q \in \mathbb{R}^{n_\xi \times (n+n_\xi)}$ is introduced and appears into two terms, being multiplied by the orthogonal complement of the derivative matrix only from one side, so that $A^TPA + A^TE_0Q + Q^TE_0^TA - E^TPE < 0$.

Remark 1.1.14 (Numerical resolution). *The numerical resolution of the presented admissibility analysis conditions, as well as for the following conditions that follow in the manuscript, is massively addressed by the use of Linear Matrix Inequalities (LMIs). For more details about LMIs, please refer to Appendix A.*

1.2 Standard uncertain systems

Modeling of physical systems is subject to many sources of inaccuracies, such as resolution of sensors and their influence over the process to be modeled, nonlinearities associated to hysteresis, dry friction, backlash, dead zone, approximations to a single operation point, to cite a few. All of these imprecisions lead to a model that is not perfectly identical to reality, but there is a trade-off between accuracy and complexity of the model. A model that is too refined and complex also requires complex mathematical tools and massive computational power. Uncertain systems are a mathematical formalism that let us represent a family of dynamics within a compact and intuitive notation.

Therefore, the concept of robustness is paramount in the context of uncertain systems: we wish that the controlled system behaves within predefined metrics even though precise knowledge of the dynamics is lacking. These uncertain models are used for analysis and control synthesis and we envisage to ensure closed-loop stability and performances in spite of all the possible uncertainties.

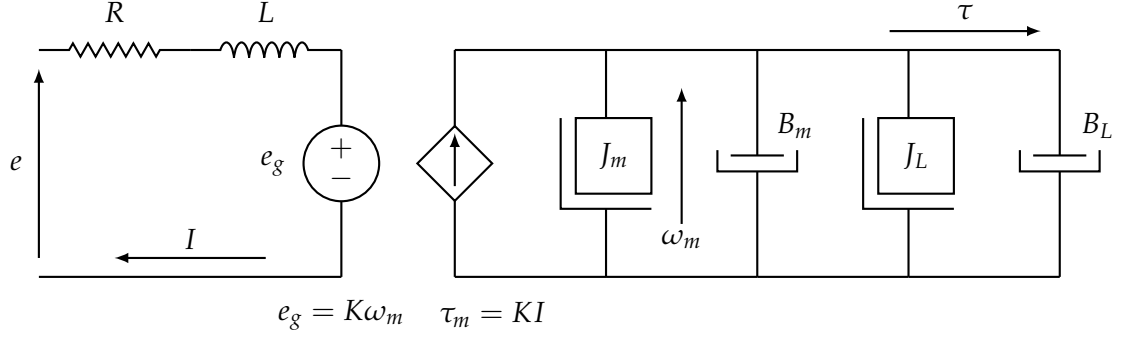

FIGURE 1.4: An electromechanical circuit

1.2.1 Example

An adapted example from [Bar94] shows the application of the uncertain formalism in describing physical systems. It depicts a DC motor driving a viscously damped inertial load.

In the electromechanical circuit given in Figure 1.4, we consider the motor constant to be $K = 0.4 \text{ V/rps}$, the load moment of inertia to be $J_L = 2 \cdot 10^{-5} \text{ kg} \cdot \text{m}^2$, the motor moment of inertia as $J_m = 2 \cdot 10^{-3} \text{ kg} \cdot \text{m}^2$, the motor damping as $B_m = 2 \cdot 10^{-5} \text{ N} \cdot \text{m/rps}$, the armature inductance as $L = 10^{-2} \text{ H}$ and the armature resistance as $R = 1 \Omega$. We suppose that the load damping B_L is imprecisely known, such that $10^{-5} \geq B_L \geq 3 \cdot 10^{-5} \text{ N} \cdot \text{m/rps}$.

A possible uncertain state representation of the electromechanical circuit is given as:

$$\begin{aligned} \begin{bmatrix} \dot{\omega}_m \\ \ddot{\omega}_m \end{bmatrix} &= \begin{bmatrix} 0 & 1 \\ -\frac{R(B_L+B_m)+K^2}{L(J_L+J_m)} & -\frac{R(J_L+J_m)+L(B_L+B_m)}{L(J_L+J_m)} \end{bmatrix} \begin{bmatrix} \omega_m \\ \dot{\omega}_m \end{bmatrix} + \begin{bmatrix} 0 \\ \frac{K}{L(J_L+J_m)} \end{bmatrix} e \\ \tau &= \begin{bmatrix} B_L & J_L \end{bmatrix} \begin{bmatrix} \omega_m \\ \dot{\omega}_m \end{bmatrix}, \end{aligned} \quad (1.44)$$

where ω_m , $\dot{\omega}_m$ and $\ddot{\omega}_m$ are respectively the angular position, velocity and acceleration of the rotor and e is the motor input voltage. In addition, in Figure 1.4, e_g is the electromotive force, I is the armature current, τ_m is the torque released to the motor and τ is the torque applied on the load.

We observe that the dynamic and output matrices of (1.44) are affinely dependent on the value of the load damping B_L . In this sense, this state representation depicts an infinity of possible dynamic behaviors in the input-output relationship.

1.2.2 Parameter-dependent systems

During the modeling of uncertain systems, it is possible that the sources of uncertainties are known, as well as their ranges of variation. When this is the case, the uncertain model can be described as a function of such variables, that we name as *parameters*. The model is, then, called as a *parameter-dependent (PD) system*.

Definition 1.2.1 (Parameter-dependent system): Parameter-dependent systems are under the form:

$$\delta[x] = A(w)x, \quad (1.45)$$

where $x \in R^n$ is the system state vector, δ is a derivative operator for the continuous-time case, and a time-shift operator for the discrete-time case, $A \in R^{n \times n}$ is the associated dynamic matrix, and $w \in \mathcal{W} \subset R^m$ is the possibly time-varying parameter vector. The set \mathcal{W} contains the possible values parameters can take. Further characterizations of the parameter's trajectories are available, so that, for the continuous-time case, $\dot{w}(t) \in \mathcal{V}$, and for the discrete-time case, $\Delta w(k) = w(k+1) - w(k) \in \mathcal{V}$. Sets \mathcal{W} and \mathcal{V} compose the *parameter admissible domain*. Prior available information about the parameters is generally given by bounds on their values and rates of variation.

Remark 1.2.2 (Time dependence). As suggested by the presence of the set \mathcal{V} , that describes the velocities of parameters, the vector of parameters w can be time-varying and represented as $w(t)$ for the continuous-time case and $w(k)$ for the discrete-time case. As a matter of fact, a continuous-time characterization $\dot{x} = A(t)x$, respectively $x(k+1) = A(k)x$ for the discrete-time one, belongs to the larger group of time-varying (TV) systems, and if the time evolution of matrices $A(t)$, or $A(k)$, can be parameterized, we refer to $A(w(t))$, or $A(w(k))$, as being a parameter-dependent characterization.

Remark 1.2.3 (Parameter's measurability). In the context of uncertain systems, parameter's values are not available for the controller in real-time. However, if we can measure the parameters, for instance, the temperature that linearly changes the operation point of a chemical reaction, we classify the system as being a classic linear parameter-varying (LPV) system. There is no difference on the analysis procedures for uncertain and classic LPV systems, because stability must be ensured for all the possible configurations of parameters, regardless of them being measurable or not. Nevertheless, the knowledge on the parameters can be useful for synthesizing a control law. When parameters cannot be assessed in real-time, a single control law is designed for working under any possible parameters' trajectories, thus being categorized as robust control. When parameters are measurable, the control law can be a function of them, and this procedure is known as control scheduling.

The class of uncertain systems is more refined and comprehensive than LTI systems, but less complex than the nonlinear one. In this sense, uncertain systems' framework is a good compromise between complexity and precision. This formalism has been widely used in different applications, such as automobilistics, aeronautics, electronics, robotics, and so on.

The parameter dependency can be represented by different forms: affine, polytopic, norm-bounded, rational, among others. In this thesis, we are particularly interested in the affine and polytopic forms, which we will discuss more in detail in the following.

Affine parameter-dependent systems

An affine parameter-dependent system is given by (1.45), in which the dynamic matrix $A(w)$ is given in an affine form and the parameters are allowed to vary inside minimum and maximum bounds. Our mathematical characterization is given as:

Definition 1.2.4 (Affine parameter-dependent system): The affine parameter-dependent system is a system of form (1.45), so that:

- Parameter values
 - Continuous-time: $\underline{w}_i \leq w_i(t) \leq \overline{w}_i, i = 1, \dots, m,$
 - Discrete-time: $\underline{w}_i \leq w_i(k) \leq \overline{w}_i, i = 1, \dots, m,$
- Parameter rates of variation
 - Continuous-time: $\underline{v}_i \leq \dot{w}_i(t) \leq \overline{v}_i, i = 1, \dots, m,$
 - Discrete-time: $\underline{v}_i \leq \Delta w_i(k) \leq \overline{v}_i, i = 1, \dots, m,$

- Dynamic matrix

- Continuous-time:

$$A(w) = A^{(0)} + \sum_{i=1}^m w_i(t) A^{(i)}, \quad (1.46)$$

- Discrete-time:

$$A(w) = A^{(0)} + \sum_{i=1}^m w_i(k) A^{(i)}. \quad (1.47)$$

Remark 1.2.5 (The constant parameter case). *The affine parameter-dependent representation in Definition 1.2.4 comprises the case of constant parameters through the choice $\underline{v}_i = \overline{v}_i = 0, i = 1, \dots, m.$*

Since each parameter $w_i, i = 1, \dots, m$ is bounded, then the parameter vector w belongs to the convex set \mathcal{W} . For the continuous-time case, this set is given by

$$\mathcal{W} = \{w(t) \in \mathbb{R}^m \mid \underline{w}_i \leq w_i(t) \leq \overline{w}_i, i = 1, \dots, m\} \quad (1.48)$$

and for the discrete-time,

$$\mathcal{W} = \{w(k) \in \mathbb{R}^m \mid \underline{w}_i \leq w_i(k) \leq \overline{w}_i, i = 1, \dots, m\}, \quad (1.49)$$

thus containing all the possible combinations between the maximum and minimum values of the entries of w . The vertices of \mathcal{W} are all the possible combinations of vectors whose entries are exclusively either the minimum bounds \underline{w}_i or the maximum bounds $\overline{w}_i, i = 1, \dots, m$. There are $N = 2^m$ vertices $w^{(i)}, i = 1, \dots, N$ that can describe the set \mathcal{W} as $\mathcal{W} = \text{Co}\{w^{(1)}, w^{(2)}, \dots, w^{(N)}\}$.

For the continuous-time case, when the parameters' rates of variation are bounded, the vector $w(t)$ belongs to the convex set \mathcal{V} that is characterized by

$$\mathcal{V} = \text{Co}\{v^{(1)}, v^{(2)}, \dots, v^{(N)}\}, \quad (1.50)$$

where $N = 2^m$. Each of the entries of the vertices $v^{(i)}$, $i = 1, \dots, N$ contains either the minimum bounds \underline{v}_i or the maximum bounds \bar{v}_i , $i = 1, \dots, m$. However, we notice that for the discrete-time case, the characterization of \mathcal{V} must respect the parameter admissible domain by enforcing that $w(k)$ remains inside \mathcal{W} for any instant k . That actually means

$$\max\{\underline{w}_i - w_i(k), \underline{v}_i\} \leq \Delta w_i(k) \leq \min\{\bar{w}_i - w_i(k), \bar{v}_i\}. \quad (1.51)$$

Finally, matrices $A(w)$ are characterized by a convex envelope whose vertices are $A(w^{(i)})$, $i = 1, \dots, N$. Therefore, $A(w) \in \text{Co}\{A(w^{(i)})\}$, $i = 1, \dots, N$.

Polytopic parameter-dependent systems

A polytopic parameter-dependent system is such that the dynamic matrix $A(w)$ and the parameters' values w are comprised within polytopes. Such system is given by the ensuing definition.

Definition 1.2.6 (Polytopic parameter-dependent system): The polytopic parameter-dependent system is of form (1.45), and:

- Parameter values

- Continuous-time: $0 \leq w_i(t) \leq 1, i = 1, \dots, N, \sum_{i=1}^N w_i(t) = 1 \forall t \geq 0,$

- Discrete-time: $0 \leq w_i(k) \leq 1, i = 1, \dots, N, \sum_{i=1}^N w_i(k) = 1 \forall k \geq 0,$

- Parameter rates of variation

- Continuous-time: $\underline{v}_i \leq \dot{w}_i(t) \leq \bar{v}_i, i = 1, \dots, N,$

- Discrete-time: $\underline{v}_i \leq \Delta w_i(k) \leq \bar{v}_i, i = 1, \dots, N,$

- Dynamic matrix

- Continuous-time:

$$A(w) = \sum_{i=1}^N w_i(t) A^{(i)}, \quad (1.52)$$

- Discrete-time:

$$A(w) = \sum_{i=1}^N w_i(k) A^{(i)}. \quad (1.53)$$

Remark 1.2.7 (The constant parameter case). *The polytopic parameter-dependent representation in Definition 1.2.6 encompasses the case of constant parameters by choosing $v_i = \bar{v}_i = 0$, $i = 1, \dots, N$, in accordance with the affine parameter-dependent representation (cf. Remark 1.2.5).*

Calculating the continuous-time derivative of the parameter condition $\sum_{i=1}^N w_i(t) = 1$, and the discrete-time rate of variation of $\sum_{i=1}^N w_i(k) = 1$, we obtain respectively

$\sum_{i=1}^N \dot{w}_i(t) = 0$ and $\sum_{i=1}^N \Delta w_i(k) = 0$. This is a requirement that a characterization of the parameter rates of variation domain must obey in order to respect the parameter admissible domain. If this is not the case, we may find restrictive analysis conditions.

For the continuous-time case [Che+07; GC06], we consider a polytope of admissible velocities \mathcal{V} as

$$\mathcal{V} = \{v \in \mathbb{R}^N, v \in \text{Co}\{g^1, \dots, g^h\} \mid \sum_{i=1}^N g_i^j = 0, j = 1 \dots h\}. \quad (1.54)$$

Vectors g^i are such that $\|g^i\|_\infty \leq \beta$, $i = 1 \dots h$.

However, for the discrete-time case we must respect not only the condition $\sum_{i=1}^N w_i(k) = 1$, but also take into account the current values of parameters. We remark that the polytope of allowed velocities might change over time because

$$\max\{\underline{w}_i - w_i(k), v_i\} \leq \Delta w_i(k) \leq \min\{\bar{w}_i - w_i(k), \bar{v}_i\}. \quad (1.55)$$

In [OP08; OP09], the authors formalize the dependence between the parameters' values and their current possible rates of variation, and propose LMI conditions for the stability analysis of uncertain systems that consider this relationship.

The set of admissible parameters values and parameters' rates of variation is often referred as *admissible polytope* or *consistent polytope*, but its actual construction is not simple. We notice that a clear definition of the set \mathcal{V} is complex for both continuous and discrete-time systems. Because of that, different works [GC06; SBN06; OP08; OP09] have attempted to provide characterizations that combine low complexity and numerical tractability.

Finally, matrices $A(w)$ are characterized by an envelope whose vertices are $A^{(i)}$, $i = 1, \dots, N$. Therefore, $A(w) \in \text{Co}\{A^{(i)}\}$, $i = 1, \dots, N$.

Remark 1.2.8 (Conversion polytopic-affine). *For the case of time-invariant parameter-dependent systems, a conversion between the affine and polytopic formulations can be performed. In the case of time-varying parameters, the conversion between velocities in affine and polytopic representations is more complex than the one employed for the parameters' values, because of the velocity coupling and the requirement that the parameters always remain in the parameter admissible domain.*

1.2.3 Stability analysis of uncertain systems

The stability analysis of an uncertain system is a complex problem because asymptotic convergence of the states must be verified for all possible values and trajectories of parameters. To tackle this task, different types of Lyapunov functions have been used in the literature. A brief discussion about such systems and the employed Lyapunov functions follow.

The general conditions for a candidate function to be an actual Lyapunov function for a given system are given in the following.

Lemma 1.2.9 (Existence of a Lyapunov function): The candidate function $V(X, w)$, having dependencies in the state vector X and in the vector of parameters $w \in \mathcal{W}$, with $\delta[w] \in \mathcal{V}$ is a Lyapunov function for a given dynamical system of interest if the conditions are verified:

$$V(X(t), w(t)) > 0 \forall X(t) \neq 0, w(t) \in \mathcal{W}, t > 0; \quad (1.56)$$

Continuous-time:

$$\frac{d}{dt}V(X(t), w(t)) < 0 \forall X(t) \neq 0, w(t) \in \mathcal{W}, \dot{w} \in \mathcal{V}, t > 0, \quad (1.57)$$

Discrete-time:

$$\begin{aligned} \Delta V(X(t), w(t)) = V(X(t+1), w(t+1)) - V(X(t), w(t)) < 0 \forall X(t) \neq 0, w(t) \in \mathcal{W}, \\ \Delta w = w(t+1) - w(t) \in \mathcal{V}, t > 0. \end{aligned} \quad (1.58)$$

In this case, $V(X, w)$ is a Lyapunov function that guarantees the asymptotic convergence of the state vector towards zero. Conditions (1.56) and (1.57) are, respectively, the positive-definiteness of a Lyapunov function and the negative-definiteness of its time derivative associated to a continuous-time system. Conditions given (1.56) and (1.58) are the positive-definiteness of a Lyapunov function and the negative-definiteness of its rate of variation associated to a discrete-time system. In the discrete-time case, we recall that the time dependence can be represented by the variable k .

Quadratic Lyapunov functions

Quadratic Lyapunov functions are Lyapunov functions that are quadratic in the state vector and assume the form

$$V(x, w) = x^T P(w)x. \quad (1.59)$$

In the following, we present different dependencies a Lyapunov function candidate (1.59) may display with respect to the parameter vector, and to which classes of systems these functions are used for robust stability analysis purposes.

Lemma 1.2.10 (Parameter-dependent quadratic stability): The uncertain system (1.45) is quadratically stable with a parameter-dependent Lyapunov function (1.59) if the following conditions are verified:

- Positive-definiteness of the Lyapunov function candidate (1.59):

$$P(w) > 0 \quad \forall w \in \mathcal{W}. \quad (1.60)$$

- Negative-definiteness of the time rate of variation of (1.59):

- Continuous-time:

$$\begin{aligned} A^T(w(t))P(w(t)) + P(w(t))A(w(t)) + \frac{d}{dt}P(w(t)) < 0 \\ \forall w(t) \in \mathcal{W}, \dot{w}(t) \in \mathcal{V}, t \geq 0. \end{aligned} \quad (1.61)$$

- Discrete-time:

$$\begin{aligned} A^T(w(k))P(w(k+1))A(w(k)) - P(w(k)) < 0 \\ \forall w \in \mathcal{W}, \Delta w(k) \in \mathcal{V}, k \geq 0. \end{aligned} \quad (1.62)$$

Conditions (1.60), (1.61) and (1.62) can be expressed in different ways depending on the type of parameter dependence. On the following, we present different cases namely *parameter independent, affine/polytopic parameter-dependent and homogeneously parameter-dependent Lyapunov functions*.

Corollary 1.2.11 (Quadratic stability): The uncertain system (1.45) is stable with respect to a parameter-independent Lyapunov function if conditions (1.60), (1.61) and (1.62) are satisfied with $P(w) = P$. In this case $\frac{d}{dt}P(w(t)) = 0$ in (1.61) and $P(w(k+1)) = P(w(k)) = P$ in (1.62).

This quadratic stability criterion is convenient for its simplicity, leading to numerically tractable conditions for robust stability analysis, robust control and robust filter design [MP03]. This choice of Lyapunov functions is robust with respect to the parameter's trajectories. Indeed, if an uncertain system is stable by means of a parameter-independent Lyapunov function, it is stable for every possible values of parameters, and any arbitrarily fast parameters trajectories. This fact is easily remarkable by the fact that the term $\frac{d}{dt}P(w(t))$ is null in (1.61) and $P(w(k+1)) = P(w(k)) = P$ in (1.62) and any infinitely big variation on the parameters is invisible to the referred conditions. However, the existence of a common Lyapunov function is a strong requirement for the case of uncertain systems either with time-invariant parameters or with parameters varying with bounded rates of variation, because a single matrix P is researched for ensuring the stability of the whole uncertainty domain. As a matter of fact, one may be unable to prove the stability of a stable uncertain system by means of a common quadratic Lyapunov function.

This issue of conservativeness is an invitation for more general classes of Lyapunov functions with polynomial dependence on the parameter vector. Indeed, the knowledge of the parameters' domain can be used by adding extra degrees of freedom to the Lyapunov function's structure. It is expected to obtain less restrictive results because

parameter-independent Lyapunov functions are a particular case of the parameter-dependent type. The parameter dependence can be of degree 1, on the so-called *affine/polytopic quadratic Lyapunov functions* [OBG99; Pea+00], of degree 2, being called as *biquadratic Lyapunov functions* [TS99], or of degree equal or higher than two, named as *homogeneous polynomially parameter-dependent quadratic Lyapunov functions* [Che+03b; OP07; OBP08]. Such Lyapunov functions can be employed to the stability analysis of uncertain systems whose parameters are either time-invariant, or time-varying with bounded rates of variation. We deploy the use of these Lyapunov functions below.

Corollary 1.2.12 (Affine/polytopic quadratic stability): The uncertain system (1.45) is stable with respect to an affine/polytopic parameter-dependent Lyapunov function if conditions (1.60), (1.61) and (1.62) are satisfied for

$$P(w) = P^{(0)} + \sum_{i=1}^m w_i P^{(i)} \quad (1.63)$$

if the sought Lyapunov function is affine, characterizing (1.45) as *affinely quadratically stable* [GAC96], and

$$P(w) = \sum_{i=1}^N w_i P^{(i)} \quad (1.64)$$

if the sought Lyapunov function is polytopic.

Corollary 1.2.13 (Stability analysis of uncertain systems using homogeneous polynomially parameter-dependent quadratic Lyapunov functions): The uncertain system (1.45) is stable with respect to a homogeneous polynomially parameter-dependent quadratic Lyapunov function that is homogeneous of degree s on the parameter vector w if conditions (1.60), (1.61) or (1.62) are satisfied with

$$P(w) = \sum_{k \in \mathcal{K}(s)} w_1^{k_1} w_2^{k_2} \dots w_N^{k_N} P^{(k)}, \quad (1.65)$$

where $k = [k_1 \ k_2 \ \dots \ k_N]$, $P^{(k)} \in \mathbb{R}^{n \times n} \ \forall k \in \mathcal{K}(s)$ and $k \in \mathcal{K}(s)$ is such that $\sum_{i=1}^N k_i = s$.

The definition here displayed comes from [OP07] for a polytopic parameter-dependent system. The same type of system is addressed in works [Che+03b; OBP08].

Results in the literature point out that conservatism in robust stability analysis results might be reduced when we progressively increase the degree of parameter dependence in a Lyapunov function. However, stability by means of a Lyapunov function that is quadratic in the state vector is not a necessary condition for the stability of an uncertain system. This fact led to the research of even less conservative results through the use of Lyapunov functions that are no longer quadratic with respect to the state vector.

Nonquadratic Lyapunov functions

The particular choices of Lyapunov function candidates that are quadratic in the state vector and independent or affinely/polytopically-dependent on the parameter vector are motivated by simplicity and because of the important number of mathematical tools that have been developed to handle them. However, the obtained conditions are often only sufficient, what motivates the research for less restrictive and numerically tractable stability conditions. The requirements of low conservatism of the solutions and numerical tractability of the conditions are generally related by a trade-off. On the one hand, there are works that provide different and oftentimes more complex structures of Lyapunov functions for obtaining less conservative results. On the other hand, we find in literature an effort to relax stability conditions, in order to render a criterion verifiable in a finite amount of iterations.

The idea of a non-restrictive Lyapunov function is apprehended by the concept of universality, here quoted:

Definition 1.2.14 (Universality [AAA12]): A given class of Lyapunov functions is said to be universal for the uncertain system under consideration if the robust stability of the system is equivalent to the existence of a Lyapunov function belonging to the class.

The concept of universality has been a propeller of the research of Lyapunov functions of various different forms. For instance, homogeneous polynomial Lyapunov functions are known to be a universal class for uncertain systems [BM95; Che+03a], and piecewise quadratic and polyhedral Lyapunov functions are not conservative for robust stability analysis and robust control synthesis of uncertain systems with time-varying structured uncertainties [Che+03a].

The present section brings two types of nonlinear Lyapunov functions that have been studied aiming for numerical solvability and absence of conservatism.

- Polyhedral: This is a universal class of Lyapunov functions for uncertain systems [Boy+94; BM95; Ama06; AAA12], and it is given in the form

$$V(x) = \max_{i=1,\dots,a} v_i^T x, \quad (1.66)$$

where $v_i, i = 1, \dots, a$ are appropriate row vectors. The whole set of polyhedral functions is spanned for an optimal search when $a \rightarrow \infty$.

- Homogeneous polynomial: This is also a universal class of Lyapunov functions for uncertain systems [Zel94; BM95; Che+03a; Alt06; Che11], and it is defined for containing homogeneous polynomial dependence on the state vector and/or the parameter vector. This functions are also called as "smooth" polyhedral Lyapunov functions [BM99; AAA12]. Some possibilities can be found below:

- Classic homogeneous polynomial Lyapunov functions (HPLFs): A homogeneous polynomial Lyapunov function of degree $2q$ is given by

$$V_{2q}(x) = \sum_{i_1, \dots, i_n} p_{i_1 i_2 \dots i_n} x_1^{i_1} x_2^{i_2} \dots x_n^{i_n}, \quad (1.67)$$

where $i_1, \dots, i_n \in \mathbb{Z}_{\geq 0}$ and $\sum_{j=1}^n i_j = 2q$.

- Homogeneously Parameter-dependent Homogeneous Polynomial Lyapunov functions (HPD-HPLFs) [Che+07]: This class of functions is homogeneously dependent both on the state and on the parameter values, as follows:

$$V_{2q,s}(x(t), w(t)) = \sum_{\substack{i \in \mathbb{N}^m, j \in \mathbb{N}^n \\ \sum_{k=1}^n j_k = 2q, \sum_{k=1}^m i_k = s}} a_{i,j} w^i x^j. \quad (1.68)$$

Homogeneous polynomial Lyapunov functions have been a great subject of interest during this thesis, and they are presented in detail in an ensuing section.

1.2.4 Mathematical tools for numerical tractability

The aforementioned Lyapunov function candidates generate conditions that are not easily exploitable because they require an infinite amount of conditions to be satisfied. Because of that, a number of techniques has been used to render the conditions numerically tractable.

Quadratic separation

This technique is also known as the utilization of *slack variables*. After the work of [OBG99], the use of slack variables appear in the numerical implementation of several robust stability criteria in different works [DB01; LP03a; LCF04; Bar11b; BSC12]. These variables can not only characterize more degrees of freedom that lead to less conservatism, but they also render a robust stability problem convex by decoupling dynamic and Lyapunov matrices. As an example, a realization of the use of slack variables is found in [Pea+00], where continuous and discrete-time examples are found for the robust stability analysis of an uncertain system through a polytopic Lyapunov function.

Theorem 1.2.15 ([Pea+00]). *Consider an uncertain system (1.45) whose dynamic matrices are of form (1.52) for the continuous-time case and (1.53) for the discrete-time case. The parameters w are uncertain, but time-invariant. Also consider a polytopic Lyapunov function candidate whose Lyapunov matrix is of form (1.64).*

The uncertain system is robustly stable if there exists matrices F and $G \in \mathbb{R}^{n \times n}$ and N symmetric positive-definite matrices $P^{(i)}$, $i = 1, \dots, N$ such that, for the continuous-time case,

one finds:

$$\begin{bmatrix} \mathcal{H}e(\mathcal{F}A^{(i)}) & P^{(i)} - F + A^{(i)T}G \\ \star & -\mathcal{H}e(G) \end{bmatrix} < 0, \quad (1.69)$$

and for the discrete-time case,

$$\begin{bmatrix} -P^{(i)} + \mathcal{H}e(\mathcal{F}A^{(i)}) & -F + A^{(i)T}G \\ \star & P^{(i)} - \mathcal{H}e(G) \end{bmatrix} < 0. \quad (1.70)$$

Matrices F and G are the so-called slack variables and matrices $P^{(i)}$, $i = 1, \dots, N$ are the Lyapunov matrices from the polytopic Lyapunov function. Please note that inequalities (1.69) and (1.70) are linear in the decision variables $P^{(i)}$, F and G . The equivalence between forms (1.61) and (1.69), and respectively of (1.62) and (1.70), is proved in [Pea+00].

Sum of polynomials

The method referred in this thesis as sum of polynomials has been explicated in works such as [RP01; RP02; LP03b; LP03a; OP08] and it reduces the infinite amount of inequality conditions to a finite amount that is bound from above by diagonal matrices whose non null entries come from the coefficients of positive semidefinite polynomials. An example of the use of such technique follows:

Theorem 1.2.16 ([RP01] - Robust stability). *Consider a discrete-time polytopic parameter-dependent uncertain system (1.45) whose dynamic matrix is given by (1.53) and a polytopic parameter-dependent Lyapunov function whose Lyapunov matrix is given by (1.64).*

The uncertain system is robustly stable by means of the given Lyapunov function if there exist positive-definite Lyapunov matrices $P^{(i)}$, $i = 1, \dots, N$ such that

$$A^{T(i)}P^{(i)}A^{(i)} - P^{(i)} < -I_n, \quad (1.71)$$

$$i = 1, \dots, N,$$

$$A^{T(i)}P^{(i)}A^{(j)} + A^{T(j)}P^{(j)}A^{(i)} + A^{T(i)}P^{(j)}A^{(i)} - 2P^{(i)} - P^{(j)} < \frac{1}{(N-1)^2}I_n, \quad (1.72)$$

$$i = 1, \dots, N, j \neq i, j = 1, \dots, N,$$

$$\begin{aligned} & A^{T(j)}P^{(i)}A^{(k)} + A^{T(k)}P^{(i)}A^{(j)} + A^{T(i)}P^{(j)}A^{(k)} + \\ & + A^{T(k)}P^{(j)}A^{(i)} + A^{T(i)}P^{(k)}A^{(j)} + A^{T(j)}P^{(k)}A^{(i)} - 2(P^{(i)} + P^{(j)} + P^{(k)}) < \frac{6}{(N-1)^2}I_n, \end{aligned} \quad (1.73)$$

$$i = 1, \dots, N-2, j = i+1, \dots, N-1, k = j+1, \dots, N.$$

Indeed, replacing the definitions of the dynamic matrix (1.53) and the Lyapunov matrix (1.64) into the stability condition (1.62), one obtains

$$\begin{aligned}
& \sum_{i=1}^N w_i^3 (A^{T(i)} P^{(i)} A^{(i)} - P^{(i)}) \\
& - \sum_{i=1}^N \sum_{j=1; j \neq i}^N w_i^2 w_j (A^{T(i)} P^{(i)} A^{(j)} + A^{T(j)} P^{(i)} A^{(i)} + A^{T(i)} P^{(j)} A^{(i)} - 2P^{(i)} - P^{(j)}) \\
& - 6 \sum_{i=1}^N \sum_{j=1; j \neq i}^N \sum_{k=1; k \neq i, j}^N w_i w_j w_k (A^{T(j)} P^{(i)} A^{(k)} + A^{T(k)} P^{(i)} A^{(j)} + A^{T(i)} P^{(j)} A^{(k)} \\
& \quad + A^{T(k)} P^{(j)} A^{(i)} + A^{T(i)} P^{(k)} A^{(j)} + A^{T(j)} P^{(k)} A^{(i)} \\
& \quad - 2(P^{(i)} + P^{(j)} + P^{(k)})) < 0 \\
& \forall w(t) \in \mathcal{W}, \dot{w}(t) \in \mathcal{V}, t \geq 0.
\end{aligned} \tag{1.74}$$

If conditions (1.71) to (1.73) hold, then the left side of inequality (1.74) is upper bounded by the sum

$$\left(\sum_{i=1}^N w_i^3 - \frac{1}{(N-1)^2} \sum_{i=1}^N \sum_{j=1; j \neq i}^N w_i^2 w_j - \frac{6}{(N-1)^2} \sum_{i=1}^N \sum_{j=1; j \neq i}^N \sum_{k=1; k \neq i, j}^N w_i w_j w_k \right) \cdot (-I_n). \tag{1.75}$$

The expression in (1.75) is negative-semidefinite because the sums of polynomials within the left parenthesis are equal to $\frac{\Theta}{(N-1)} + \frac{\Omega}{2(N-1)^2}$, where Θ and Ω are positive semidefinite since they given by:

$$\Theta = \sum_{i=1}^N \sum_{j=1}^N w_i (w_i - w_j)^2 \tag{1.76}$$

$$= (N-1) \sum_{i=1}^N w_i^3 - \sum_{j=1; j \neq i}^N w_i^2 w_j$$

$$\Omega = \sum_{i=1}^N \sum_{j=1; j \neq i}^N \sum_{k=1; k \neq i, j}^N w_k (w_i - w_j)^2 \tag{1.77}$$

$$= 2(N-2) \sum_{j=1; j \neq i}^N w_i^2 w_j - 12 \sum_{i=1}^N \sum_{j=1; j \neq i}^N \sum_{k=1; k \neq i, j}^N w_i w_j w_k.$$

Therefore, based on this sum of polynomials technique, the stability condition (1.62) is satisfied whenever conditions (1.71) to (1.73) hold.

Squares of homogeneous polynomials

This method is found in the work of [Che+07] for rendering convex the robust analysis of continuous-time parameter-dependent uncertain systems by means of homogeneously parameter-dependent homogeneous polynomial Lyapunov functions. It is stated as:

Theorem 1.2.17 ([Che+07] - Squares of homogeneous polynomials). *Let $g(w)$, $g(w) : \mathbb{R}^m \rightarrow \mathbb{R}$ be a homogeneous form. Then*

$$g(w) > 0 \forall w \in \mathcal{W} \iff g(sq(w)) > 0 \forall w \in \mathbb{R}^m \setminus \{0_m\}, \quad (1.78)$$

where $sq(w) \in \mathbb{R}^m$ is the vector whose entries are the square of the entries of w :

$$sq(w) = \begin{bmatrix} w_1^2 & w_2^2 & \dots & w_m^2 \end{bmatrix}^T.$$

This convexification method is further exploited on Chapter 4.

Other convexification techniques

The aforementioned convexification techniques have been used throughout the following chapters of the thesis, but some other techniques are also cited here below:

- **Kharitonov test:** the Kharitonov test addresses the robust stability of an interval polynomial family. It states that the robust stability of this family is verified by the stability of four Kharitonov polynomials that are built from the maximum and the minimum values of the parameters.

One of the reasons of the importance of this method is historical. It is responsible for reviving the interest on the research of parametric uncertainties on the 80s [Bar94]. It is also powerful for consisting in an algebraic analysis. The Kharitonov test is nonconservative when each coefficient of the characteristic polynomials is a function of a single parameter [GAC96]. On the other hand, it can be conservative for disconsidering the existing couplings among parameters [Aou12].

- **S-procedure:** This technique is based upon the constraint that a quadratic form is negative-definite whenever another set of quadratic forms is negative-definite [Boy+94]. The S-procedure can conveniently lead to structuring the negative-definiteness problem in a LMI fashion.

This technique was used, for instance, in the work of [XSF97] to provide robust stability conditions for a time-varying uncertain system containing two vertices, and in [Alm+01] for the more general case of an arbitrary number of vertices.

- **Multiconvexity approach:** This convexification technique consists in imposing convexity on the robust admissibility conditions in each direction of the parameter space in order to ensure global convexity. In [GAC94; GAC96; Bar01], definitions and uses of the multiconvexity technique are found. One example is here cited:

Definition 1.2.18 ([GAC96] - Multiconvexity): Consider a scalar quadratic function of $w \in \mathbb{R}^m$ as

$$f(w) = \alpha_0 + \sum_i \alpha_i w_i + \sum_{i < j} \beta_{ij} w_i w_j + \sum_i \gamma_i w_i^2, \quad (1.79)$$

and assume that $f(w)$ is multiconvex, that is $2\gamma_i = \frac{\partial^2}{\partial w_i^2} f(w) \geq 0$ for $i = 1 \dots m$. Then $f(w)$ is negative in \mathcal{W} if and only if it takes negative values at the vertices of the parameter set \mathcal{W} .

In this work, the definition of multiconvexity is applied for obtaining robust stability conditions for an affine uncertain continuous-time system with time-varying parameters subject to bounded rates of variation by means of an affine parameter-dependent Lyapunov function.

1.2.5 Homogeneous Polynomial Lyapunov functions

Homogeneous Polynomial Lyapunov functions are set aside for a more thorough discussion because they are universal for uncertain systems and because a number of interesting results combining techniques for quadratic Lyapunov functions have been used. This is possible because one can rewrite a homogeneous polynomial Lyapunov function in a quadratic standard form where the new state vector is given by a nonlinear transformation over the state vector of the original system. Conditions derived from these Lyapunov functions can be non-conservative for a given uncertain system if the degree of the homogeneous forms is properly chosen. In this thesis, we are particularly interested in this class of Lyapunov functions not only because of their aforementioned desirable attributes, but also because they had only been employed for the stability analysis of uncertain standard systems, but not for the admissibility analysis of uncertain descriptor systems. Important properties associated to this type of Lyapunov functions are presented in the following.

Definition 1.2.19 (Base vector of homogeneous forms): The base vector of homogeneous forms of degree q of a vector $x \in R^n$ is here denoted by $x^{[q]} \in R^{d(n,q)}$, and is composed by all the integer powered monomials of degree q that can be made from the entries of x . These components are given as

$$x_l^{[q]} = x_1^{i_1} x_2^{i_2} \dots x_n^{i_n}, \quad i_1 + i_2 + \dots + i_n = q$$

$$i_1, i_2, \dots, i_n \geq 0, \quad l \in \{1, \dots, d(n, q)\}$$

where $d(n, q) = \frac{(n+q-1)!}{(n-1)!(q)!}$.

The formula $d(n, q)$ is, by definition, the *multiset coefficient* or *multiset number*, ie. the number of multisets of cardinality q having elements taken from a finite set of cardinality n .

Remark 1.2.20 (Power transformation). The nonlinear mapping between $x^{[q]}$ and x is known as a *power transformation of degree q* of x .

Definition 1.2.21 (Square matricial representation): Consider the homogeneous polynomial Lyapunov function (1.67). Its square matricial representation (SMR) is defined

as

$$V_{2q}(x) = x^{[q]T} P x^{[q]}. \quad (1.80)$$

The matrix $P = P^T \in \mathbb{R}^{d(n,q) \times d(n,q)}$ in (1.80) is non-unique, and can be parameterized as $P + P_0$, $P_0 \in \mathcal{P}$ being

$$\mathcal{P} = \{P_0 = P_0^T \in \mathbb{R}^{d(n,q) \times d(n,q)} \mid x^{[q]T} P_0 x^{[q]} = 0 \forall x \in \mathbb{R}^n\}. \quad (1.81)$$

The set \mathcal{P} is a linear space whose dimension is

$$d_{\mathcal{P}}(n, q) = \frac{1}{2} d(n, q)(d(n, q) + 1) - d(n, 2q). \quad (1.82)$$

Indeed, any matrix of \mathcal{P} can be written as a linear combination of $d_{\mathcal{P}}(n, q)$ matrices, leading to an affine parameterization of the coefficient matrix P . Therefore, the complete square matricial representation (CSMR) of a homogeneous polynomial Lyapunov function is given by:

$$\begin{aligned} V_{2q}(x) &= x^{[q]T} P(\gamma) x^{[q]} = x^{[q]T} (P + P_0(\gamma)) x^{[q]} \\ &= x^{[q]T} \left(P + \sum_{i=1}^{d_{\mathcal{P}}(n, q)} \gamma_i P_{0i} \right) x^{[q]} \end{aligned} \quad (1.83)$$

where the matrices P_{0i} form a base of the linear space (1.81).

Remark 1.2.22 (About the dimension of \mathcal{P}). The size of set \mathcal{P} , given by $d_{\mathcal{P}}$ (1.82), informs the amount of degrees of freedom associated to the CSMR form. We note that the Lyapunov matrix P in (1.80) is of size $d(n, q) \times d(n, q)$. Due to its symmetry, P has $\frac{1}{2} d(n, q)(d(n, q) + 1)$ free entries, namely either its upper or the lower triangle. We also remark that the function $V_{2q}(x)$ is a polynomial of degree $2q$ in the state vector, what means that $V_{2q}(x)$ is a weighted sum of $d(n, 2q)$ monomials. Therefore, the degrees of freedom due to the size of the Lyapunov matrix P that are not used to describe the polynomial $V_{2q}(x)$ are of size $d_{\mathcal{P}}$.

Definition 1.2.23 (Extended matrix): Consider the generic system $\dot{x} = Ax$. The extended matrix $A_{[q]} \in \mathbb{R}^{d(n,q) \times d(n,q)}$ is defined by

$$\frac{d}{dt} x^{[q]} = \frac{\partial x^{[q]}}{\partial x} Ax = A_{[q]} x^{[q]}.$$

The transformation introduced in this definition is such that, if $A, B \in \mathbb{R}^{n \times n}$ and $\alpha, \beta \in \mathbb{R}$, then,

$$(\alpha A + \beta B)_{[q]} = \alpha A_{[q]} + \beta B_{[q]}.$$

For a complete presentation of the properties of this transformation, the interested reader can see [Bro73; BZ83] and [Zel94].

Definition 1.2.24 (Extended system): Consider an affine parameter-dependent standard system

$$\dot{x}(t) = \left(A^{(0)} + \sum_{i=1}^m w_i(t) A^{(i)} \right) x(t), \quad (1.84)$$

and let $A_{[q]}^{(0)}$ and $A_{[q]}^{(i)}$, $i = 1, \dots, m$ denote the extended matrices of $A^{(0)}$ and $A^{(i)}$, respectively. Then, the associated *extended system* is given by:

$$\begin{aligned} \frac{d}{dt} x^{[q]}(t) &= A(w(t))_{[q]} x^{[q]}(t) \\ &= \left(A_{[q]}^{(0)} + \sum_{i=1}^m w_i(t) A_{[q]}^{(i)} \right) x^{[q]}(t). \end{aligned} \quad (1.85)$$

Likewise, consider a polytopic parameter-dependent standard system

$$\dot{x}(t) = \left(\sum_{i=1}^N w_i(t) A^{(i)} \right) x(t), \quad (1.86)$$

and let $A_{[q]}^{(i)}$ be the extended matrices of $A^{(i)}$. The associated *extended system* is given by:

$$\begin{aligned} \frac{d}{dt} x^{[q]}(t) &= A(w(t))_{[q]} x^{[q]}(t) \\ &= \left(\sum_{i=1}^N w_i(t) A_{[q]}^{(i)} \right) x^{[q]}(t). \end{aligned} \quad (1.87)$$

Remark 1.2.25 (Relation between quadratic and homogeneous polynomial Lyapunov functions). *The time-derivative of the Lyapunov function $V_{2q}(x)$ along the trajectories of the extended system (1.85) equals the time-derivative of $V_{2q}(x)$ along the trajectories of (1.84) ie. $\left. \frac{d}{dt} V_{2q}(x) \right|_{(1.85)} = \left. \frac{d}{dt} V_{2q}(x) \right|_{(1.84)}$ (see Lemma 3 in [Zel94] for more details). Therefore, the problem of computing a HPLF of degree $2q$ for the system (1.84) is equivalent to computing a quadratic LF for the extended system (1.85). The reasoning here developed for the affine descriptor case is valid for the polytopic descriptor case by considering the uncertain system as (1.86) and the extended system (1.87).*

It has been emphasized in the literature that there is a linear mapping between the entries of the dynamic matrices of the original and the extended systems [JW01]. A parameterization of this linear mapping is proposed in Chapter 3.

1.3 Uncertain descriptor systems

Uncertain descriptor systems gather the properties of both descriptor and uncertain systems presented so far. Therefore, they can represent simultaneously time-varying behavior, algebraic constraints and non-causal phenomena. A number of applications

has been found for this formalism, such as in aeronautics, robotics, economics, electronics, and so on.

The use of the uncertain descriptor formalism can be useful to reduce the degree of dependence on the parameters. It is known that a parameter-dependent system with rational dependence on parameters can be rewritten as an equivalent descriptor system with affine dependence on parameters. An application that highlights the importance of such property is the study of stability of parameter-dependent systems. The affine dependence may render the stability conditions convex with respect to these parameters, being a positive factor in numerical evaluations.

As for standard uncertain systems, where E is full-rank, several different types of parameter dependences may take place, such as affine, polytopic, rational, norm-bound. Here, we focus on systems with affine and polytopic dependence on parameters.

Definition 1.3.1 (Uncertain descriptor system): An autonomous uncertain descriptor system is given as

$$E\delta[X] = A(w)X, \quad (1.88)$$

where $X \in R^{(n+n_\xi)}$ is the system state vector, δ is the derivative operator in the continuous-time case and a time-shift operator in the discrete-time case, $E \in R^{(n+n_\xi) \times (n+n_\xi)}$ is the derivative matrix, $\text{rank}(E) = n$, $A \in R^{(n+n_\xi) \times (n+n_\xi)}$ is the associated dynamic matrix and $w \in R^m$ is the parameter vector. If w is a time-dependent vector, we refer to (1.88) as an *uncertain parameter-dependent descriptor system with time-varying parameters*. Vector w varies inside the domain \mathcal{W} , and the allowed rates of variation of w are comprised in the domain \mathcal{V} . Definitions of sets \mathcal{W} and \mathcal{V} are found in section 1.2.2, depending whether the system is continuous-time or discrete-time, affine or polytopic.

Therefore, a continuous-time uncertain descriptor system is given by

$$E\dot{X}(t) = A(w(t))X(t) \quad (1.89)$$

and a discrete-time uncertain descriptor system has the form

$$EX(k+1) = A(w(k))X(k). \quad (1.90)$$

Remark 1.3.2 (About parameter-dependence). A parameter-dependent descriptor system can be given by parameter-dependent matrices $(E(w), A(w))$. In this manuscript, as explicated in (1.88), we consider $E(w) = E$. Actually, this consideration is not restrictive because, for the systems in which there are uncertainties on the E matrix, a state augmentation method can be used in order to obtain a constant derivative matrix as in the form (2.1) [SBF08].

1.3.1 Example

Consider the autonomous version of **Example 1** of section 1.1.1. It shows an RLC circuit network whose mathematical expression is given through a descriptor formalism,

here below:

$$\begin{bmatrix} 0 & 0 & 0 & 0 \\ 0 & 0 & 0 & 0 \\ L & 0 & 0 & 0 \\ 0 & 0 & 0 & C \end{bmatrix} \begin{bmatrix} \dot{I}(t) \\ \dot{V}_R(t) \\ \dot{V}_L(t) \\ \dot{V}_C(t) \end{bmatrix} = \begin{bmatrix} 0 & 1 & 1 & 1 \\ R & -1 & 0 & 0 \\ 0 & 0 & 1 & 0 \\ 1 & 0 & 0 & 0 \end{bmatrix} \cdot \begin{bmatrix} I(t) \\ V_R(t) \\ V_L(t) \\ V_C(t) \end{bmatrix}. \quad (1.91)$$

Now, consider the following values for the components: the capacitance is $C = 4\mu F$, the inductance is given by $L = 5mH$ and the resistance is variable, comprised in the interval $1.5\Omega \leq R \leq 100\Omega$. We observe that the system contains one constraint given by the Kirchhoff's laws, and throughout the infinity of possible values that the resistance R can assume, the behavior of this system can be either under- or overdamped.

1.3.2 The singular value decomposition normal form

Analogously to the prior discussion in section 1.1.2, there is a SVD normal form associated to system (1.88). Given that matrix E is constant and of rank n , there exist time-independent invertible matrices S and T such that $SET = Bdiag(I_n, 0_{n_\xi})$. A coordinate transformation $\bar{X} = T^{-1}X$ produces the equivalent SVD normal form of (1.88):

$$\begin{bmatrix} I_n & 0 \\ 0 & 0_{n_\xi} \end{bmatrix} \delta[\bar{X}] = SA(w)T\bar{X} = \begin{bmatrix} A_{11}(w) & A_{12}(w) \\ A_{21}(w) & A_{22}(w) \end{bmatrix} \bar{X}.$$

We observe that this notation is similar to a collection of equations, as given below:

$$\delta[x] = A_{11}(w)x + A_{12}(w)\xi \quad (1.92a)$$

$$0^{n_\xi \times 1} = A_{21}(w)x + A_{22}(w)\xi. \quad (1.92b)$$

in which the first is a dynamic equation, and the second is an algebraic equation that reveals the constraints among state variables. The state vector \bar{X} is divided in two parts: $x \in R^n$ is a vector composed of the dynamic states, and $\xi \in R^{n_\xi}$ regroups the algebraic states. We recall that this system formulation is intuitive for many physical systems such as for robots with joint constraints [MG89; CH08].

Following the lines of the section 1.1.2, one can retrieve the SVD normal form of the uncertain descriptor system (1.88) through SVD or rank decomposition of matrix E .

Remark 1.3.3 (Studies on a time-invariant derivative matrix). *As mentioned in Remark 1.3.2, our study is here limited to a time-invariant derivative matrix E . Note that a time-varying matrix E may have time-varying rank, leading to a SVD normal form with dynamic and algebraic parts of variable sizes.*

1.3.3 Properties of uncertain descriptor systems

As for time-invariant descriptor systems, definitions of regularity, absence of impulsive modes or causality, stability and admissibility (cf. section 1.1.3) are given below. The set of pairs $(E, A(w))$ is:

- **regular** if $\det(\lambda E - A(w)) \neq 0$ for some $\lambda \in \mathbb{C}$ and all $w \in \mathcal{W}$, ensuring existence and uniqueness of solutions;
- **impulse-free**, or **causal**, if $\deg(\det(\lambda E - A(w))) = \text{rank}(E)$ for every possible values of parameter vector $w \in \mathcal{W}$;
- **stable**, if the state vector converges to equilibrium once the system is autonomous. Stability will be discussed more in detail in the ensuing sections.
- **robustly admissible**, if it is regular, impulse-free and stable for every possible trajectory of $w(t) \in \mathcal{W}$ and, for continuous-time systems, $\dot{w}(t) \in \mathcal{V}$, while for discrete-time systems, $\Delta w(k) \in \mathcal{V}$.

Remark 1.3.4 (SVD form and admissibility analysis of uncertain descriptor systems). *For the case of time-invariant uncertain descriptor systems, stability is verified by the stability of the finite solutions of the characteristic polynomial $\det(\lambda E - A(w)) = 0$. Under the SVD normal form (1.3.2), the pair $(E, A(w))$ is admissible if and only if $A_{22}(w)$ matrix is invertible for every $w \in \mathcal{W}$ and the equivalent standard form*

$$\delta[x] = (A_{11}(w) - A_{12}(w)A_{22}(w)^{-1}A_{21}(w))x \quad (1.93)$$

is stable for all $w \in \mathcal{W}$. The invertibility of $A_{22}(w)$ guarantees regularity and absence of impulsive modes of the pair $(E, A(w))$, while ensuring that we are able to re-write the algebraic vector as a function of the state vector [BL87; IT02].

For the case of time-varying descriptor systems, stability of the finite solutions of the characteristic polynomial $\det(\lambda E - A(w)) = 0$ is not sufficient for ensuring the stability of the descriptor system. That happens because certain choices of parameter's rate of variation may destabilize the system. Under the SVD normal form, the pair $(E, A(w))$ is admissible if and only if $A_{22}(w)$ matrix is invertible for every $w \in \mathcal{W}$ and the equivalent standard form (1.93) is stable for every possible parameter's values and trajectories.

1.3.4 Polytopic/affine uncertain descriptor systems

In this manuscript, parameter dependence in uncertain descriptor systems is of order one, so that the dynamic matrices $A(w)$ can be comprised inside a convex polytope, while matrix E remains constant. Polytopic and affine forms of a uncertain descriptor system are given below.

Affine uncertain descriptor systems

Affine uncertain descriptor systems are given as (1.88), in which parameter values w , parameter rates of variation \dot{w} or Δw and dynamic matrix $A(w)$ are given accordingly to Definition 1.2.4.

Polytopic uncertain descriptor systems

Polytopic uncertain descriptor systems are in the form of (1.88). Parameter values w , parameter rates of variation \dot{w} or Δw and dynamic matrix $A(w)$ are set as in Definition 1.2.6.

Remark 1.3.5 (Polytopic/affine dependence and the equivalent standard form). *Recalling Remark 1.3.4, if an uncertain descriptor system is known to be regular and impulse-free, its stability can be evaluated through its equivalent standard form (1.93) for all possible parameter's values and parameters' rates of variation.*

Though the same holds for polytopic and affine uncertainty structures in $(E, A(w))$, the associate form (1.93) no longer retains a polytopic or affine parameter dependence and constitutes a nonconvex admissibility conditions, whose numerical treatment is rather complex [SBF08].

1.3.5 Admissibility analysis of uncertain descriptor systems

The tool set for analysis and control of uncertain descriptor systems is being expanded throughout the years and it is naturally founded upon previous works in descriptor systems and in uncertain systems fields. Here we present some Lyapunov functions that have been proposed in the area so far, namely parameter-independent and parameter-dependent quadratic Lyapunov functions. Please note that the types of Lyapunov functions found in the literature are all quadratic with respect to the state vector. Indeed, to the best of our knowledge, Lyapunov functions that are nonquadratic in the states have not been employed for the analysis of uncertain descriptor systems, and this is an open field that this thesis aims to explore.

Recalling the general definition of a Lyapunov function in Lemma 1.2.9, henceforth we bring some structures of Lyapunov functions used for the admissibility analysis of uncertain descriptor systems found in the literature.

In the following, consider the parameter-dependent Lyapunov function candidate given by

$$V(X, w) = X^T E^T P(w) E X, \quad (1.94)$$

that has clear correlation with the Lyapunov function candidate given in (1.30). Conditions that such a candidate must fulfill for the admissibility analysis of uncertain descriptor systems can be found in the following.

Admissibility analysis of continuous-time uncertain descriptor systems

The Lyapunov candidate (1.94) is given as

$$V(X(t), w(t)) = X(t)^T E^T P(w(t)) E X(t) \quad (1.95)$$

when dealing with a continuous-time system. Conditions over the function and its time derivative are imposed so that it is able to ascertain the admissibility of a continuous-time uncertain descriptor system of form (1.89).

- Positive-definiteness of the the Lyapunov function:

The positive-definiteness of the scalar Lyapunov function (1.95) is given by the condition $E^T P(w(t)) E \geq 0 \forall w(t) \in \mathcal{W}$ because of its quadratic dependence with respect to the state vector. We note that this condition is not strict, but given that the Lyapunov function is, after all, a scalar function, a sufficient condition, but not necessary, for fulfilling the requirement is conveniently given by a strict inequality:

$$P(w(t)) > 0 \forall w(t) \in \mathcal{W}, t > 0. \quad (1.96)$$

- Negative-definiteness of the time derivative of the Lyapunov function:

The time-derivative of (1.95) given by

$$\begin{aligned} \frac{d}{dt} V(X(t), w(t)) &= X(t)^T (A^T(w(t)) P(w(t)) E + E^T P(w(t)) A(w(t))) \\ &\quad + \frac{d}{dt} P(w(t)) X(t) \end{aligned} \quad (1.97)$$

is kept negative-definite when

$$\begin{aligned} A^T(w(t)) P(w(t)) E + E^T P(w(t)) A(w(t)) + \frac{d}{dt} P(w(t)) &< 0 \\ \forall w(t) \in \mathcal{W}, \dot{w}(t) \in \mathcal{V}, t > 0. \end{aligned} \quad (1.98)$$

Admissibility analysis of discrete-time uncertain descriptor systems

The admissibility analysis of the discrete-time version is assessed by means of a Lyapunov function in an analogous fashion of the continuous-time version, being:

$$V(X(k), w(k)) = X(k)^T E^T P(w(k)) E X(k). \quad (1.99)$$

Conditions for the existence of such a Lyapunov function that verifies the admissibility of system (1.90) follow:

- Positive-definiteness of the Lyapunov function: This condition is similar to its continuous-time counterpart, being given as $E^T P(w(k)) E \geq 0 \forall w(k) \in \mathcal{W}$. Likewise, though the given inequality is not strict, the positive-definiteness of the

Lyapunov matrix is sufficient for maintaining the positive-definiteness of the Lyapunov function. In other terms, the condition consists in

$$P(w(k)) > 0 \forall w(k) \in \mathcal{W}, k \geq 0. \quad (1.100)$$

- Negative-definiteness of the time rate of variation of the Lyapunov function:

Given that the time rate of variation of the Lyapunov function candidate (1.99) is given as

$$\begin{aligned} \Delta V(X(k), w(k)) &= V(X(k+1), w(k+1), k+1) - V(X(k), w(k), k) \\ &= X(k)^T (A(w(k))^T P(w(k+1)) A(w(k)) - E^T P(w(k)) E) X(k), \end{aligned} \quad (1.101)$$

this condition is fulfilled once

$$\begin{aligned} A(w(k))^T P(w(k+1)) A(w(k)) - E^T P(w(k)) E &< 0 \\ \forall w(k) \in \mathcal{W}, \Delta w(k) \in \mathcal{V}, k \geq 0. \end{aligned} \quad (1.102)$$

With the admissibility conditions presented, we derive in the following the variants for different types of Lyapunov functions.

Corollary 1.3.6 (Admissibility analysis of uncertain descriptor systems using quadratic parameter-independent Lyapunov functions): The continuous-time uncertain system (1.89) (respectively, the discrete-time uncertain system (1.90)) is admissible by means of a quadratic parameter-independent Lyapunov function if conditions (1.96) and (1.98) (respectively, conditions (1.100) and (1.102)) hold for the choice $P(w) = P$.

The quadratic parameter-independent Lyapunov function appeared in the section 1.1.4 for the LTI case and is here evoked in the context of uncertain descriptor systems. Differently from the section presented before, the admissibility must be ensured for all the possible values and variations of the parameters.

Quadratic parameter-independent Lyapunov functions have been employed both for the case of time-invariant uncertain parameters and for the case of time-varying parameters subject to arbitrary rates of variation. In [KF03], nonstrict conditions are found for the admissibility analysis of time-invariant polytopic parameter-dependent systems. These conditions come from a choice of Lyapunov function as $V(x, w) = X^T E^T P X$. We remark that this choice leads to the function (1.99) once $P = P(w)E$. The obtained conditions are given as nonstrict inequalities in the positivity-definiteness of the Lyapunov function. Indeed, nonstrict inequalities may lead to numerical issues and are avoided with the Lyapunov function structure as (1.99).

As a matter of fact, the parameter-independent Lyapunov function (1.99) is robust for arbitrary rates of change in the parameters because the terms related to their variations, namely $\frac{d}{dt}P(w(t))$ in (1.98) and $P(w(k+1))$ in (1.102), are respectively null and

independent of the ensuing values of parameters. However, for an uncertain descriptor system with known bounds on the parameter's rates of variation, such information can be used for reducing the conservatism of the analysis. This fact also motivates the use of a Lyapunov function containing more degrees of freedom than the parameter-independent case, leading to the ensuing parameter dependences.

Corollary 1.3.7 (Admissibility analysis of uncertain descriptor systems using quadratic affine/polytopic parameter-dependent Lyapunov functions): The uncertain system (1.89) (respectively (1.90)) is admissible by means of a quadratic *affine* parameter-dependent Lyapunov function if conditions (1.96) and (1.98) ((1.100) and (1.102)) hold for the choice $P(w) = P^{(0)} + \sum_{i=1}^m w_i P^{(i)}$, here recalled from (1.63). For the case of a quadratic *polytopic* parameter-dependent Lyapunov function, the aforementioned conditions must hold for $P(w) = \sum_{i=1}^N w_i P^{(i)}$, as previously given in (1.64).

Time dependence on the parameters was here omitted for clarity in the representation.

In the work of [Fan02], a Lyapunov function of form $V(X, w) = X^T E^T P(w) X$ is proposed, and once its Lyapunov matrix is set as $P(w) = P(w)E$, we retrieve the Lyapunov function given by (1.94). In this work, sufficient conditions for the stability robustness of time-invariant polytopic parameter-dependent uncertain descriptor systems with a polytopic parameter-dependent derivative matrix E were provided.

In [GCS03], we find conditions for the existence of a Lyapunov function that are similar to the ones found in [Fan02]. There, the robust D-admissibility of a polytopic parameter-dependent uncertain descriptor system subject to time-invariant parameters can be found by means of a parameter-dependent Lyapunov function. In [MAS03], the synthesis of output-feedback gain-scheduling controllers for standard LPV systems is proposed through a descriptor formulation, where the conditions are also derived from a Lyapunov function of an identical form of [Fan02; GCS03].

The conditions presented in these works contain nonstrict inequalities that are undesirable from the perspective of numerical implementation. This was a strong motivation for the use of Lyapunov functions of different structures that would produce admissibility conditions presented as strict inequalities. Choices found in the literature comprise the full structure of the Lyapunov function (1.94).

Indeed, in the more recent works of [YBC08; SBF08; Bar11b; Bar11a; BSC12; BSC13], admissibility conditions for uncertain descriptor systems subject to possibly time-varying parameters are proposed in the form of strict inequalities.

Admissibility analysis of uncertain descriptor systems using quadratic Lyapunov functions with polynomial dependence on parameters

Following the course of the investigations in the time-invariant descriptor systems, there is interest in producing Lyapunov functions containing more complex dependences in the parameter vector, and one of these efforts follows below, being expressed

through the use of a Lyapunov function containing terms that are quadratic functions of the parameters. In the work of [BSC12], such a function is used for the admissibility analysis of discrete-time uncertain descriptor systems. A prior reformatting of the uncertain descriptor system is proposed as $A(w(k)) = \mathcal{A} \begin{bmatrix} I_{n+n_\xi} \\ w(k) \otimes I_{n+n_\xi} \end{bmatrix}$. The Lyapunov matrix is given as $P(w(k)) = \begin{bmatrix} I_{n+n_\xi} \\ w(k) \otimes I_{n+n_\xi} \end{bmatrix}^T \mathcal{P} \begin{bmatrix} I_{n+n_\xi} \\ w(k) \otimes I_{n+n_\xi} \end{bmatrix}$, what leads to a parameter-dependent Lyapunov matrix containing parameter dependences from degrees 0 to 2.

Furthermore, in the work [SF05], we find conditions for the robust admissibility analysis of time-invariant affine parameter-dependent uncertain descriptor systems containing a single parameter. There, a quadratic Lyapunov function with polynomial dependence of degree d_w on the parameter is proposed, such that $P(w) = \sum_{i=0}^{d_w} w^i P^{(i)}$.

1.3.6 Mathematical tools for numerical tractability

The existence conditions for the Lyapunov functions, as presented in the precedent section, are often not numerically tractable. Their evaluation relies upon the use of mathematical tools, such as slack variables. A collection of examples using these techniques follows below.

Quadratic separation

The use of slack variables is presented onto different forms for the uncertain descriptor formalism. Some works [Bar11b; Bar11a] propose the use of slack variables of reduced size, while others [GCS03; YBC08; BSC12; BSC13] deal with an analogous form of what is found on the standard uncertain case (cf. inequalities (1.69) and (1.70)). Examples of both sorts are here cited:

Theorem 1.3.8 ([Bar11a]). *The discrete-time polytopic parameter-dependent uncertain descriptor system (1.90) is admissible by means of a polytopic parameter-dependent Lyapunov function if there exist symmetric positive-definite matrices $P^{(i)} \in \mathbb{R}^{n \times n}$, $i = 1, \dots, N$, F and $G \in \mathbb{R}^{n \times n}$, X_1 and $X_3 \in \mathbb{R}^{n_\xi \times n}$ and $X_2 \in \mathbb{R}^{n_\xi \times n_\xi}$ such that*

$$\begin{bmatrix} \mathcal{H}e \left(\begin{bmatrix} F & X_3 \\ 0 & X_2 \end{bmatrix} S A^{(i)} T \right) + \begin{bmatrix} P^{(i)} & 0 \\ 0 & 0 \end{bmatrix} & & \\ & \star & \\ \begin{bmatrix} G & X_1 \end{bmatrix} S A^{(i)} T + \begin{bmatrix} F^T & 0 \end{bmatrix} & \mathcal{H}e(G) - (qP^{(i)} + (1-q)P^{(j)}) & \end{bmatrix} < 0 \quad (1.103)$$

holds for every (i, j) within the index sets. Here, S and $T \in \mathbb{R}^{(n+n_\xi) \times (n+n_\xi)}$ are the matrices of the SVD normal form and q stands for an indicator function. Its value is 1 for time-invariant parameters and 0 for time-varying parameters with arbitrary rates of variation.

Theorem 1.3.9 ([BSC12]). *The discrete-time affine uncertain descriptor system (1.90) is robustly admissible if there exist matrices $P^{(i)} = P^{(i)T} \in \mathbb{R}^{(n+n_\xi) \times (n+n_\xi)}$, $Q^{(i)} \in \mathbb{R}^{(n+n_\xi) \times n_\xi}$,*

$i = 0 \dots m$, F and $G \in \mathbf{R}^{(n+n_\xi) \times (n+n_\xi)}$ satisfying the following LMIs:

$$P(w) > 0 \forall w \in \mathcal{W}, \quad (1.104)$$

$$\begin{bmatrix} -EP(w)E + \mathcal{H}e(FA(w)) & \star \\ E_0Q(w) + GA(w) - F^T & P(w + \Delta w) - \mathcal{H}e(G) \end{bmatrix} < 0 \forall w \in \mathcal{W}, \Delta w \in \mathcal{V}. \quad (1.105)$$

In this case, the associated affine parameter-dependent Lyapunov matrix is in the form (1.63).

We note that the choice of constant slack variables in this example led condition (1.105) to be a LMI, but slack variables need not always be parameter-independent for leading to convex inequality conditions.

Sum of polynomials

In [Fan02], we find numerically tractable conditions for the analysis of time-invariant parameter-dependent uncertain descriptor systems that are derived from the inequalities below, for the continuous-time case:

There exists a Lyapunov matrix $P(w)$ such that

$$P(w)E(w) = (P(w)E(w))^T \geq 0, \quad (1.106)$$

$$P(w)A(w) + (P(w)A(w))^T < 0 \forall w \in \mathcal{W}. \quad (1.107)$$

These numerically tractable conditions are obtained when conditions (1.106) and (1.107) are bounded by parameter-dependent semipositive-definite polynomials, as follows:

Theorem 1.3.10 ([Fan02]). *If there exist semipositive-definite matrices $Q, Z \in \mathbf{R}^{(n+n_\xi) \times (n+n_\xi)}$ and $P^{(i)}$, $i = 1, \dots, N$ such that*

$$P^{(i)}E^{(i)} = (P^{(i)}E^{(i)})^T \geq Q, \quad (1.108)$$

$$i = 1, \dots, N;$$

$$P^{(i)}E^{(j)} + P^{(j)}E^{(i)} = (P^{(i)}E^{(j)} + P^{(j)}E^{(i)})^T \geq \frac{-2}{N-1}Q, \quad (1.109)$$

$$i = 1, \dots, N-1, j = i+1, \dots, N;$$

$$P^{(i)}A^{(i)} + (P^{(i)}A^{(i)})^T < -Z, \quad (1.110)$$

$$i = 1, \dots, N;$$

$$P^{(i)}A^{(j)} + P^{(j)}A^{(i)} + (P^{(i)}A^{(j)} + P^{(j)}A^{(i)})^T < \frac{2}{N-1}Z, \quad (1.111)$$

$$i = 1, \dots, N-1, j = i+1, \dots, N.$$

Use of Finsler's lemma

The Finsler's lemma (cf. Appendix A) was used in the works [BSC12; BSC13] to lead to convex conditions in the admissibility analysis problem of an uncertain descriptor

system through a parameter-dependent Lyapunov function that is quadratic on the parameters. In these works, the Finsler's lemma was used to remove the nonlinear parameter dependence from the inequality conditions, so that the resulting admissibility conditions contain parameter dependence of degree 1.

1.4 Conclusion

In the present chapter, a collection of concepts and mathematical tools was recalled from the literature. The class of dynamical systems of interest is the uncertain descriptor one. Therefore, we discuss separately about descriptor systems, then uncertain systems and, finally, about uncertain descriptor systems. In each of these sections, examples found in the literature are referred. Stability properties of uncertain systems and admissibility properties of LTI descriptor and uncertain descriptor systems are presented, as well as their calculation through different types of Lyapunov functions.

We would like to stress that the reduction of conservatism in the choice of the methods to assess the stability or admissibility of the addressed classes of systems is still an open subject of research. Furthermore, Lyapunov functions that are nonquadratic in the state vector have never been employed for the admissibility analysis of uncertain descriptor systems. This open field is precisely the motivation and the subject of the study of the next chapters that gather our main contributions.

Chapter 2

Admissibility analysis of discrete-time time-varying descriptor systems

2.1 Introduction

In the present chapter, we present our contributions that deals with the *admissibility analysis of discrete-time descriptor systems*. First, we deploy necessary and sufficient admissibility criteria for time-varying discrete-time descriptor systems. These criteria are an extension of some conditions found in the literature concerning the time-invariant case. Then, we use this novel criteria to obtain sufficient admissibility conditions for the polytopic parameter-dependent case. These conditions are LMI, so numerically tractable, contain parameter-dependent slack variables and are obtained through the upper bounds provided by positive-semidefinite polynomials.

Therefore, in this chapter, we first deal with time-varying discrete-time descriptor systems, recalling notions from Chapter 1 and presenting the necessary and sufficient conditions for the admissibility analysis of such systems. Later, we evoke concepts about polytopic discrete-time descriptor systems and present sufficient conditions for the admissibility analysis problem. Finally, we bring numerical examples that highlight the advantages of the proposed sufficient conditions and we draw conclusions from the presented techniques.

2.2 Time-varying (TV) descriptor systems

In this section, we explicit properties of TV descriptor systems, that are closely related to uncertain descriptor systems (*cf.* section 1.3). Then, we introduce a novel and important assumption for TV descriptor systems in the SVD normal form that is followed by new admissibility analysis conditions.

2.2.1 Class of systems

Consider the uncertain linear time-varying descriptor system:

$$EX(k+1) = A(k)X(k) \quad (2.1)$$

where $X(k) \in \mathbb{R}^{n+n_\xi}$ is the state vector and $A(k) \in \mathbb{R}^{(n+n_\xi) \times (n+n_\xi)}$ is a time-varying matrix function. $E \in \mathbb{R}^{(n+n_\xi) \times (n+n_\xi)}$ is a constant and, possibly, singular matrix with $\text{rank}(E) = n$.

Remark 2.2.1 (The time-dependent derivative matrix case). *We recall from Remark 1.3.2 that a system containing a time-varying derivative matrix E can be recast into the form (2.1) through a state augmentation method.*

We recall from Figure 1.1 that a linear time-varying descriptor system can be seen as a linear parameter-varying system with a particular choice of parameters' trajectories. Conversely, a time-varying system can be converted in a parameter-varying system once the time dependences are encapsulated in parameters that are related to each other through the implicit time variable. Because of this close relationship between LTV and LPV systems, we recollect the properties of uncertain descriptor systems evoked in section 1.3.3 with little adaptation for the LTV case.

- System (2.1) is *regular* if $\det(\lambda E - A(k)) \neq 0$ for some $\lambda \in \mathbb{C}$ and for all $k \geq 0$.
- The discrete-time descriptor system (2.1) for which the relation $\deg(\det(\lambda E - A(k))) = \text{rank}(E)$ holds for all $k \geq 0$ is called *causal*.
- The discrete-time descriptor system (2.1) is *asymptotically stable* if there exists a Lyapunov function guaranteeing the asymptotic convergence of state vector $X(k)$ towards zero.
- A discrete-time descriptor system is *admissible* if it is regular, causal and stable.

We also recall from section 1.3.2 the SVD normal form of an uncertain descriptor system. It implies the existence of full-rank matrices S and $T \in \mathbb{R}^{(n+n_\xi) \times (n+n_\xi)}$ such

that $SET = B \text{diag}(I_n, 0_{n_\xi})$, $\bar{X} = T^{-1}X = \begin{bmatrix} x \\ \xi \end{bmatrix}$:

$$\begin{bmatrix} I_n & \\ & 0_{n_\xi} \end{bmatrix} \bar{X}(k+1) = SA(k)T\bar{X}(k) = \begin{bmatrix} A_{11}(k) & A_{12}(k) \\ A_{21}(k) & A_{22}(k) \end{bmatrix} \bar{X}(k). \quad (2.2)$$

Furthermore, as discussed in Remark 1.3.4 for the uncertain case in the SVD normal form, this equivalent LTV system is regular and causal if and only if matrix $A_{22}(k)$ is invertible for all $k \geq 0$. The asymptotic stability of the dynamic part of state vector $\bar{X}(k)$ is guaranteed by the asymptotic stability of time-varying state matrix $A_{11}(k) - A_{12}(k)A_{22}^{-1}(k)A_{21}(k)$. In order to also guarantee the convergence towards zero of the algebraic part of state vector $\bar{X}(k)$ when the dynamic part converges towards zero, it is necessary and sufficient that matrix $A_{22}^{-1}(k)$ remains bounded for all $k \geq 0$. Therefore, the following assumption has to be made.

Assumption 1. The matrix $A_{22}(k)$ involved in the equivalent SVD normal form (2.2) of system (2.1) is invertible and its inverse is bounded for all $k \geq 0$.

To seize the importance of the aforementioned assumption, consider a system (2.1) given as

$$\begin{bmatrix} 1 & 0 \\ 0 & 0 \end{bmatrix} X(k+1) = \begin{bmatrix} 1/2 & 0 \\ k+5 & e^{-k} \end{bmatrix} X(k). \quad (2.3)$$

Given that the algebraic variable is computed as $\xi = -A_{22}^{-1}(k)A_{21}(k)x$, for this specific example $\xi = -(k+5)e^k x$. We verify that the algebraic variable is prone to diverge even when the dynamic variable approaches the equilibrium. Thus, Assumption 1 ensures that if the dynamic part of the state vector converges to zero, the algebraic part will also converge to equilibrium. Despite the importance of this assumption, it had never been discussed in the literature, to the best of our knowledge.

In the following, for systems of form (2.1), we focus on admissibility analysis assessed by means of a quadratic time-varying Lyapunov function:

$$V(k, X(k)) = x^T(k)E^T P(k)EX(k), \quad (2.4)$$

in correlation with the Lyapunov function candidate presented in (1.99).

2.2.2 New admissibility analysis conditions for TV descriptor systems

This section presents equivalent conditions for the admissibility analysis of discrete time-varying descriptor systems.

Theorem 2.2.2. [SPB17b] *The descriptor system (2.1) under Assumption 1 is admissible with a quadratic time-varying Lyapunov function (2.4) if and only if one of the following equivalent conditions hold for all $k \geq 0$:*

(i) *there exists a bounded matrix $P(k) = P(k)^T$ such that*

$$E^T P(k)E \geq 0, \quad A^T(k)P(k+1)A(k) - E^T P(k)E < 0, \quad (2.5)$$

(ii) *there exist bounded matrices $P(k) = P(k)^T > 0$ and $Q(k) = Q(k)^T$ such that*

$$A^T(k)(P(k+1) - E_0 Q(k+1)E_0^T)A(k) - E^T P(k)E < 0, \quad (2.6)$$

(iii) *there exist bounded matrices $P(k) > 0$, $Q(k) = Q(k)^T$, $F(k, k+1)$ and $G(k, k+1)$ such that*

$$\left[\begin{array}{c|c} -E^T P(k)E + \mathcal{H}e(F(k, k+1)A(k)) & \star \\ \hline G^T(k, k+1)A(k) - F^T(k, k+1) & P(k+1) - E_0 Q(k+1)E_0^T \\ & -\mathcal{H}e(G(k, k+1)) \end{array} \right] < 0. \quad (2.7)$$

Proof. (i) \leftrightarrow (ii) [ZXS08] presented the proof for the LTI case and the extension of their result to the time-varying case may be done by following the same considerations. In

addition, this proof can also be done by using the results of [BSC12]. Indeed, our condition (i) is equivalent to the admissibility of time-varying system based on Theorem 1.(a) of [BSC12] by choosing $R(k) = -\frac{1}{2}Q(k)E_0^T A(k)$.

(ii)→(iii) Suppose (2.6) holds. Then, for any positive-definite matrix $P(k+1)$ and for any general symmetric matrix $Q(k+1)$ there always exists a general matrix $G(k, k+1)$ such that

$$P(k+1) - E_0 Q(k+1) E_0^T - \mathcal{H}e(G(k, k+1)) < 0. \quad (2.8)$$

Therefore, gathering (2.8) and (2.6) yields

$$\begin{aligned} & \text{Bdiag}(A^T(k)(P(k+1) - E_0 Q(k+1) E_0^T) A(k) - E^T P(k) E, \\ & P(k+1) - E_0 Q(k+1) E_0^T - \mathcal{H}e(G(k, k+1))) < 0. \end{aligned} \quad (2.9)$$

Left- and right-multiplying (2.9) with matrices $\begin{bmatrix} I_{n+n_\xi} & -A^T(k) \\ 0_{n+n_\xi} & I_{n+n_\xi} \end{bmatrix}$ and, respectively, $\begin{bmatrix} I_{n+n_\xi} & 0_{n+n_\xi} \\ -A(k) & I_{n+n_\xi} \end{bmatrix}$ and using the notation

$$F(k, k+1) = A^T(k)(P(k+1) - E_0 Q(k+1) E_0^T - G(k, k+1))$$

leads to (2.7).

(ii)←(iii) Left- and right-multiplying the inequality (2.7) by $\begin{bmatrix} I_{n+n_\xi} & A^T(k) \end{bmatrix}$ and, respectively, $\begin{bmatrix} I_{n+n_\xi} & A^T(k) \end{bmatrix}^T$ leads to the inequality (2.6). \square

Remark 2.2.3. Note that in the case of LTI descriptor systems i.e. $A(k) = A$, the equivalent conditions of Theorem 2.2.2 cover the ones proposed by [CD12] (see Theorem 4).

Remark 2.2.4. Although [BSC12] proposed, allegedly necessary and sufficient, admissibility conditions for time-varying descriptor systems (see their Theorem 1), their results are only sufficient. As a matter of fact, for proving the equivalence of their conditions, non-causal variable attributions were made, generating the loss of necessity. However, when reducing the class of systems to the case of uncertain descriptor systems with time-invariant uncertainties i.e. $A(k) = A(w)$ with w belonging to a convex domain, the conditions proposed by [BSC12] become necessary and sufficient. Indeed, in this case $P(k+1) = P(k) = P(w)$, $Q(k+1) = Q(k) = Q(w)$, and the conditions of [BSC12] are equivalent to our conditions (ii) and (iii) in Theorem 2.2.2 by choosing $R(k) = -\frac{1}{2}Q(k)E_0^T A(k) = -\frac{1}{2}Q(w)E_0^T A(w)$. Unlike the results of [BSC12], we exploit in the following parameter-dependent slack variables $F(w)$ and $G(w)$ in order to obtain less conservative and easily tractable new admissibility conditions as sustained by our numerical examples.

2.3 Polytopic descriptor systems

In this section, we aim to provide numerically tractable admissibility analysis conditions in the form of LMIs from the novel conditions presented in the previous section.

For so, we choose to use TV descriptor systems in a polytopic structure, so that the time dependence is given in terms of time-varying polytopic parameters. The choice of slack variables in the admissibility analysis conditions follows the same principle, becoming parameter-dependent. In the following, the structure of the time-varying parameters is presented, as well as the form of the parameter-dependent slack variables and the LMI admissibility conditions that use them.

Therefore, consider the polytopic time-varying descriptor system:

$$EX(k+1) = A(w(k))X(k), \quad (2.10)$$

as given in (1.90) and discussed in Section 1.3.4. The real time-varying parameters are $w(k) = [w_1(k) \ \dots \ w_N(k)]^T$ and they lie in the unit simplex

$$w(k) \in \mathcal{W} = \{w \in \mathbb{R}^N \mid \sum_{i=1}^N w_i = 1, \ 0 \leq w_i \leq 1\} \quad \forall k \geq 0.$$

We assume that the system dynamic matrix $A(w(k))$ is given by $A(w(k)) = \sum_{i=1}^N w_i(k)A^{(i)}$ as proposed in (1.53) and therefore, it belongs to a convex polytopic set whose vertices are $A^{(i)}$.

2.3.1 Parameters' variation space

Many physical systems exhibit bounded rates of variation on their parameters due to physical limitations, according to [OP09]. Furthermore, information of the maximum allowed variations may be taken into account in the admissibility analysis in order to reduce conservatism on the approaches based on parameter-independent Lyapunov functions. The concept of the set $(w(k), \Delta w(k))$ of admissible values for the parameter's polytope was described by [OP08; OP09] and referred as *consistent polytope* by [TS99; SBN06; BSC12]. In the works of [OP08; OP09], all the parameters are subject to the same variation span. Meanwhile, for different variation bounds for each parameter, there is no precise algorithm or technique for obtaining the convex hull of a consistent polytope, to the best of authors' knowledge.

On the other hand, different variation bounds are referred by [BSC12], but no algorithm or technique for obtaining the convex hull of a consistent polytope is precisely provided.

In the following, we introduce in more detail the description of the parameters' variation space proposed in [OP08], that is used for retrieving numerically tractable admissibility conditions. We consider that each component $w_i(k)$ of the vector of parameters $w(k)$ has bounded rates of variation given by:

$$-b \leq \Delta w_i(k) = w_i(k+1) - w_i(k) \leq b, \ i = 1, \dots, N, \ b \in \mathbb{R}_{\geq 0}. \quad (2.11)$$

Note that $b = 0$ corresponds to time-invariant parameters, referred by [OP08] as *frozen parameters*, while $b = 1$ corresponds to time-varying parameters that are allowed to vary arbitrarily inside the simplex \mathcal{W} . When $0 < b < 1$, the set of all admissible values of $w(k)$ and $\Delta w(k)$ is defined by all possible values of $w(k)$ and $\Delta w(k)$ such that $w(k+1)$ belongs to simplex \mathcal{W} . Therefore, we have the relation: $\sum_{i=1}^N \Delta w_i(k) = 0$, $\forall k \geq 0$. Indeed, the values of $\Delta w_i(k)$ are highly dependent of $w_i(k)$:

$$-bw_i \leq \Delta w_i \leq b(1 - w_i), \quad i = 1, \dots, N \quad (2.12)$$

and hence, the vector $\Delta w(k)$ belongs to a polytope whose vertices are h^j , $j = 1, \dots, N$, where

$$[h^1 \ h^2 \ \dots \ h^N] = b \begin{bmatrix} 1 - w_1 & -w_1 & -w_1 & \dots \\ -w_2 & 1 - w_2 & -w_2 & \dots \\ \vdots & \vdots & \ddots & \dots \\ -w_N & -w_N & -w_N & 1 - w_N \end{bmatrix}.$$

Therefore, $\Delta w(k)$ can be described as

$$\Delta w(k) = \sum_{i=1}^N \beta_i h^i \text{ where } \beta \in \mathcal{W}.$$

Using simplex \mathcal{W} definition, it follows that $\Delta w_i = b(\beta_i - w_i)$.

For the sequel, our admissibility analysis results are based on quadratic Lyapunov function such as (2.4) with a polytopic Lyapunov matrix *i.e.*

$$V(X(k), w(k)) = x^T(k) E^T P(w(k)) E X(k), \quad P(w(k)) = \sum_{i=1}^N w_i(k) P^{(i)}, \quad (2.13)$$

as evoked in Corollary 1.3.7. Based on previous considerations, it follows that $P(w(k+1))$ is given by

$$P(w(k+1)) = (1 - b) \sum_{i=1}^N w_i P^{(i)} + b \sum_{i=1}^N \beta_i P^{(i)}.$$

This section presents admissibility analysis results for polytopic descriptor systems based on the results of our previous section. Given that inequalities (2.5) to (2.7) are not convex with regards to the unknown parameters $w(k)$, it is not possible to use LMI tools to directly solve them. However, transformations can be employed to decouple the non-linear parametric dependence on the admissibility inequality (2.7).

2.3.2 Structure of slack variables

The approaches proposed in the literature successfully rendered their respective stability (or admissibility) inequalities linear with relation to the parameters at the expense of losing the necessity property. For instance, [LP03a] gave a finite number of conditions using sum of polynomials and linearly polytopic variables $F(k, k+1) = F(k)$

TABLE 2.1: Choices of indicator functions and their implications over a matrix $M(w(k), w(k+1))$

$\eta_M \backslash \rho_M$	0	1
0	$M(w(k))$	$M(w(k+1))$
1		$M(w(k), w(k+1))$

and $G(k, k+1) = G(k)$, while [BSC12], Theorem 2, fixed constant matrices $F(k, k+1) = F$ and $G(k, k+1) = G$ all over the polytope.

However, according to our necessary and sufficient conditions stated in (2.7), the structures of $F(k, k+1)$ and $G(k, k+1)$ can be more general than the ones proposed in the aforementioned contributions. The dependence of $F(k, k+1)$ and $G(k, k+1)$ to the parameters encompasses a relation not only with $w(k)$, but also with $w(k+1)$. Aiming to exploit the numerous possibilities to define $F(k, k+1)$ and $G(k, k+1)$, we introduce two indicator functions ρ_M and η_M that are related to a given matrix M , as follows:

$$\rho_M = \begin{cases} 1, & \text{if } M = M(w(k), w(k+1)), \\ 0, & \text{if } M = M(w(k)). \end{cases}$$

$$\eta_M = \begin{cases} 1, & \text{if } M = M(w(k), w(k+1)), \\ 0, & \text{if } M = M(w(k+1)). \end{cases}$$

Therefore, we define the following matrix variables:

$$P(w(k+1)) = (1-b) \sum_{i=1}^N w_i P^{(i)} + b \sum_{j=1}^N \beta_j P^{(j)},$$

$$Q(w(k+1)) = (1-b) \sum_{i=1}^N w_i Q^{(i)} + b \sum_{j=1}^N \beta_j Q^{(j)},$$

$$F(w(k), w(k+1)) = \rho_F b \sum_{i=1}^N \sum_{j=1}^N w_i \beta_j \mathcal{F}_{\eta_F \cdot i, j} + (1 - \rho_F b) \sum_{i=1}^N w_i F_i,$$

$$G(w(k), w(k+1)) = \rho_G b \sum_{i=1}^N \sum_{j=1}^N w_i \beta_j \mathcal{G}_{\eta_G \cdot i, j} + (1 - \rho_G b) \sum_{i=1}^N w_i G_i.$$

The indicator functions η_M and ρ_M act over a given matrix M by regulating its degrees of freedom. Indeed, as indicated in Table 2.1, $\rho_M = 1$ and $\eta_M = 1$ allow us to obtain a matrix whose parameter dependence includes both $w(k)$ and $w(k+1)$. If $\rho_M = 0$, then the indicator function η_M is canceled and the matrix depends only on $w(k)$. For instance, if $\rho_F = 1$ and $\eta_F = 0$ the term $\sum_{i=1}^N \sum_{j=1}^N w_i \beta_j \mathcal{F}_{\eta_F \cdot i, j}$ of

$F(w(k), w(k+1))$ shrinks to $(\sum_{i=1}^N w_i) \cdot \sum_{j=1}^N \beta_j \mathcal{F}_{0, j} = \sum_{j=1}^N \beta_j \mathcal{F}_j$. In such a situation,

$F(w(k), w(k+1))$ depends only on $w(k+1)$ and displays a structure analogous to $P(w(k+1))$ and $Q(w(k+1))$.

2.3.3 New admissibility analysis conditions for polytopic descriptor systems

The main contribution of this chapter is presented in the following theorem and it is expressed as a new set of LMI conditions for assessing the admissibility of descriptor systems with bounded time-varying parameters.

Theorem 2.3.1. [SPB17b] *The discrete-time polytopic descriptor system (2.10) subject to parameters in the unit simplex \mathcal{W} with rates of variation given by (2.11) is admissible if there exist symmetric positive-definite matrices $P^{(i)} \in \mathbb{R}^{(n+n_\xi) \times (n+n_\xi)}$, symmetric matrices $Q^{(i)} \in \mathbb{R}^{n \times n}$, and general matrices $\mathcal{F}_{i,j}, F_i, \mathcal{G}_{i,j}, G_i \in \mathbb{R}^{(n+n_\xi) \times (n+n_\xi)}$, $i = 1, \dots, N$, $j = 1, \dots, N$ such that conditions (2.14) and (2.15) are satisfied. Moreover, the associated parameter-dependent time-varying Lyapunov matrix is given by (2.13).*

Proof. Polytopic system (2.10) is admissible if and only if (2.7) holds according to our Lemma 2.2.2. Using the definitions of $P(w(k+1))$, $Q(w(k+1))$, $F(w(k), w(k+1))$ and $G(w(k), w(k+1))$ proposed above, the left-hand side of inequality condition (2.7) in Theorem 2.2.2 can be rewritten as (2.16). Whenever conditions (2.14) and (2.15) hold, and recalling that w and β belong to unit simplex \mathcal{W} , it follows that expression (2.16), which is the left-hand side of (2.7) in Theorem 2.2.2, satisfies the condition (2.17). Moreover, the scalar that multiplies the matrix $Bdiag(I_{n+n_\xi}, 0_{n+n_\xi})$ in (2.17) can be rewritten as $\frac{1}{N-1} \sum_{m=1}^N \beta_m \left((N-1) \sum_{j=1}^N w_j^2 - 2 \sum_{j=1}^{N-1} \sum_{k=j+1}^N w_j w_k \right)$, which is positive semi-definite since $\beta_m \geq 0$ and through the following sum of powers:

$$(N-1) \sum_{k=1}^N \beta_k \sum_{i=1}^N w_i^2 - 2 \sum_{k=1}^N \beta_k \sum_{i=1}^{N-1} \sum_{j=i+1}^N w_i w_j = \sum_{k=1}^N \beta_k \left(\sum_{i=1}^{N-1} \sum_{j=i+1}^N (w_i - w_j)^2 \right) \geq 0.$$

Therefore, whenever conditions (2.14) and (2.15) are satisfied, it follows that condition (2.7) in Theorem 2.2.2 holds and system (2.10) is admissible. \square

Remark 2.3.2. *The time-invariant case is a particular case covered by (2.5), (2.6) and (2.7) for which $P(k+1) = P(k)$, $Q(k+1) = Q(k)$, $F(k, k+1) = F(k)$, and $G(k, k+1) = G(k) \forall k$. Thus, the admissibility results given in Theorem 2.3.1 boil down to the frozen parameters case, by taking $b = 0$.*

2.3.4 Numerical Examples

In this section, conditions in our Theorem 2.3.1, the ones given in [BSC12], Theorem 2, and the ones given in [Bar11a], Theorem 4.3 are compared by means of robust admissibility margins, that are the maximum κ -expansion of the convex hull $Co(E, \kappa A(k))$ that still ensure admissibility.

To perform these evaluations, a sample system from the literature (example 2 from the work of [Bar11a] referred as Bex_2) and some randomly generated examples were used. The three randomly generated systems (RGS) are defined as follows:

$$\left[\begin{array}{c|c} -E^T P^{(i)} E + \mathcal{H}e(((1 - \rho_F b) \cdot F_i + \rho_F b \mathcal{F}_{\eta_F \cdot i, k}) A^{(i)})) & \star \\ \hline ((1 - \rho_G b) \cdot G_i^T + \rho_G b \mathcal{G}_{\eta_G \cdot i, k}^T) \cdot A^{(i)} - (1 - \rho_F b) \cdot F_i^T - \rho_F b \mathcal{F}_{\eta_F \cdot i, k}^T & (1 - b) \cdot (P^{(i)} - E_0 Q^{(i)} E_0^T - \rho_G \cdot \mathcal{H}e(G_i)) \\ & + b \cdot (P^{(k)} - E_0 Q^{(k)} E_0^T - \rho_G \cdot \mathcal{H}e(\mathcal{G}_{\eta_G \cdot i, k})) \end{array} \right] < \begin{bmatrix} -I_{n+n_\xi} & \\ & 0_{n+n_\xi} \end{bmatrix}, \quad (2.14)$$

$$i = 1, \dots, N; \quad j = 1, \dots, N.$$

$$\left[\begin{array}{c|c} -E^T (P^{(i)} + P^{(j)}) E + \mathcal{H}e(((1 - \rho_F b) \cdot F_i + \rho_F b \mathcal{F}_{\eta_F \cdot i, k}) A^{(j)} + \mathcal{H}e(((1 - \rho_F b) \cdot F_j + \rho_F b \mathcal{F}_{\eta_F \cdot j, k}) A^{(i)})) & \star \\ \hline ((1 - \rho_G b) \cdot G_i^T + \rho_G b \mathcal{G}_{\eta_G \cdot i, k}^T) \cdot A^{(j)} & (1 - b) \cdot (P^{(i)} + P^{(j)} - E_0 (Q^{(i)} + Q^{(j)}) E_0^T) \\ + ((1 - \rho_G b) \cdot G_j^T + \rho_G b \mathcal{G}_{\eta_G \cdot j, k}^T) \cdot A^{(i)} & - (1 - b) \rho_G \cdot \mathcal{H}e(G_i + G_j) \\ - (1 - \rho_F b) \cdot (F_i^T + F_j^T) - \rho_F b (\mathcal{F}_{\eta_F \cdot i, k}^T + \mathcal{F}_{\eta_F \cdot j, k}^T) & + 2b \cdot (P^{(k)} - E_0 Q^{(k)} E_0^T) \\ & - \rho_G b \cdot \mathcal{H}e(\mathcal{G}_{\eta_G \cdot i, k}^T + \mathcal{G}_{\eta_G \cdot j, k}^T) \end{array} \right] < \frac{2}{(N-1)} \begin{bmatrix} I_{n+n_\xi} & \\ & 0_{n+n_\xi} \end{bmatrix}, \quad (2.15)$$

$$i = 1, \dots, N-1; \quad j = i+1, \dots, N; \quad k = 1, \dots, N.$$

left-hand side of (2.7) in Lemma 2.2.2

$$\begin{aligned}
&= \sum_{k=1}^N \beta_m \sum_{i=1}^N w_i^2 \left[\begin{array}{c|c} -E^T P^{(i)} E + \mathcal{H}e(((1 - \rho_F b) \cdot F_i + \rho_F b \mathcal{F}_{\eta_{F \cdot i, k}}) A^{(i)}) & \star \\ \hline ((1 - \rho_G b) \cdot G_i^T + \rho_G b \mathcal{G}_{\eta_{G \cdot i, k}}^T) \cdot A^{(i)} & (1 - b) \cdot (P^{(i)} - E_0 Q^{(i)} E_0^T - \rho_G \cdot \mathcal{H}e(G_i)) \\ & + b \cdot (P^{(k)} - E_0 Q^{(k)} E_0^T - \rho_G \cdot \mathcal{H}e(\mathcal{G}_{\eta_{G \cdot i, k}})) \end{array} \right] + \\
&\sum_{k=1}^N \beta_k \sum_{i=1}^{N-1} \sum_{j=j+1}^N w_i w_k \left[\begin{array}{c|c} -E^T (P^{(i)} + P^{(k)}) E + \mathcal{H}e(((1 - \rho_F b) \cdot F_i + \rho_F b \mathcal{F}_{\eta_{F \cdot i, k}}) A^{(k)}) & \star \\ + \mathcal{H}e(((1 - \rho_F b) \cdot F_k + \rho_F b \mathcal{F}_{\eta_{F \cdot j, k}}) A^{(i)}) & \\ \hline ((1 - \rho_G b) \cdot G_i^T + \rho_G b \mathcal{G}_{\eta_{G \cdot i, k}}^T) \cdot A^{(k)} & (1 - b) \cdot (P^{(i)} + P^{(k)} - E_0 (Q^{(i)} + Q^{(k)}) E_0^T \\ + ((1 - \rho_G b) \cdot G_k^T + \rho_G b \mathcal{G}_{\eta_{G \cdot j, k}}^T) \cdot A^{(i)} & - \rho_G \cdot \mathcal{H}e(G_i + G_k)) \\ - (1 - \rho_F b) \cdot (F_i^T + F_k^T) - \rho_F b (\mathcal{F}_{\eta_{F \cdot i, k}}^T + \mathcal{F}_{\eta_{F \cdot j, k}}^T) & + 2b \cdot (P^{(k)} - E_0 Q^{(k)} E_0^T) \\ & - \rho_G b \cdot \mathcal{H}e(\mathcal{G}_{\eta_{G \cdot i, k}}^T + \mathcal{G}_{\eta_{G \cdot j, k}}^T) \end{array} \right] \quad (2.16)
\end{aligned}$$

$$\left[\begin{array}{c|c} -E^T P^{(j)} E + \mathcal{H}e\{F(j, j+1) A^{(j)}\} & \star \\ \hline G^T(j, j+1) A^{(j)} - F^T(j, j+1) & P^{(j+1)} - E_0 Q^{(j+1)} E_0^T \\ & - \mathcal{H}e\{G(j, j+1)\} \end{array} \right] < - \sum_{k=1}^N \beta_k \left(\sum_{i=1}^N w_i^2 - \sum_{i=1}^{N-1} \sum_{j=i+1}^N \frac{2}{N-1} w_i w_j \right) \begin{bmatrix} I_{n+n_\xi} & \\ & 0_{n+n_\xi} \end{bmatrix} \quad (2.17)$$

Example Bex_2 :

$$E = Bdiag(I_4, 0),$$

$$A^{(1)} = \begin{bmatrix} 0.0248 & 0.2201 & -0.1472 & -0.2277 & 0.0387 \\ 0.2275 & -0.0767 & 0.0767 & -0.0626 & -0.0440 \\ 0.0442 & 0.0466 & 0.0938 & -0.1470 & 0.0949 \\ 0.0223 & 0.1898 & 0.0151 & -0.1052 & -0.2549 \\ -0.0125 & -0.2178 & 0.0815 & -0.2472 & 0.1321 \end{bmatrix},$$

$$A^{(2)} = \begin{bmatrix} 0.3567 & 0.3709 & 0.7896 & -0.3370 & 1.1710 \\ 0.1948 & 0.3811 & 0.1587 & 0.0232 & 0.5549 \\ -0.5563 & -0.1224 & 0.4842 & -0.1492 & 0.1469 \\ 0.3336 & 0.8812 & -0.5565 & 0.6562 & 0.0446 \\ 1.1669 & -0.3536 & 0.0632 & 0.2750 & 0.9339 \end{bmatrix},$$

$$A^{(3)} = \begin{bmatrix} 0.1949 & 0.1114 & 0.0837 & -0.3888 & -0.0733 \\ -0.0248 & -0.4704 & 0.3497 & 0.0521 & 0.1290 \\ -0.0252 & -0.1563 & -0.2602 & 0.2649 & 0.3457 \\ 0.0482 & -0.0678 & 0.0674 & -0.1122 & -0.2558 \\ 0.0017 & 0.2108 & -0.0577 & 0.0213 & 0.1153 \end{bmatrix}.$$

Example RGS_1 :

$$E = Bdiag(I_2, 0),$$

$$A^{(1)} = \begin{bmatrix} 0.3912 & -0.4072 & 0.4 \\ 0.0460 & 0.2556 & 0 \\ 0 & 0 & 1.2 \end{bmatrix}, \quad A^{(2)} = \begin{bmatrix} 0.0836 & 0.4008 & 0 \\ -0.3680 & -0.3420 & -0.4 \\ 0 & 0 & 1.2 \end{bmatrix},$$

$$A^{(3)} = \begin{bmatrix} 0.0204 & -0.2240 & 0.4 \\ 0.4892 & 0.4444 & -0.4 \\ 0.4000 & 0 & 1.2 \end{bmatrix}.$$

Example RGS_2 :

$$E = Bdiag(I_3, 0),$$

$$A^{(1)} = \begin{bmatrix} 0.1631 & -0.0713 & 0.0518 & 0.2840 \\ -0.0925 & -0.2532 & -0.1265 & 0.0295 \\ 0.1797 & 0.3297 & 0.4962 & 0.0407 \\ -0.1323 & -0.1194 & -0.1547 & -0.3188 \end{bmatrix},$$

$$A^{(2)} = \begin{bmatrix} -0.1551 & -0.2571 & 0.0537 & -0.2151 \\ 0.2398 & -0.3308 & -0.4228 & 0.1174 \\ 0.0911 & -0.0780 & -0.1064 & -0.3144 \\ 0.0423 & -0.1919 & 0.4452 & -0.5161 \end{bmatrix},$$

$$A^{(3)} = \begin{bmatrix} 0.2840 & 0.1739 & 0.0302 & 0.1450 \\ -0.0330 & 0.0051 & 0.1020 & 0.0902 \\ 0.0455 & 0.0607 & 0.0209 & 0.0357 \\ -0.0264 & 0.0726 & 0.2341 & -0.0458 \end{bmatrix}.$$

Example RGS_3 :

$$E = Bdiag(I_2, 0),$$

$$A^{(1)} = \begin{bmatrix} -0.0191 & -0.0162 & -0.0031 \\ -0.0232 & -0.0112 & 0.0404 \\ -0.0430 & 0.0177 & -0.0130 \end{bmatrix}, \quad A^{(2)} = \begin{bmatrix} -0.1012 & 0.0149 & 0.0526 \\ -0.0234 & 0.0152 & -0.0301 \\ 0.0166 & 0.0391 & -0.0976 \end{bmatrix},$$

$$A^{(3)} = \begin{bmatrix} 0.0057 & -0.0087 & -0.0427 \\ 0.0690 & -0.0824 & -0.0782 \\ 0.1310 & -0.0977 & -0.0203 \end{bmatrix}, \quad A^{(4)} = \begin{bmatrix} -0.0901 & 0.0796 & -0.0153 \\ 0.0278 & 0.0098 & -0.0733 \\ 0.1076 & 0.0252 & -0.0831 \end{bmatrix}.$$

Time-invariant systems

For our Theorem 2.3.1, the time-invariant case is expressed by setting $b = 0$, as pointed out in Remark 2.3.2. When we let $b = 0$, the complementary degrees of freedom given by $k + 1$ in matrices $F(k, k + 1)$ and $G(k, k + 1)$ are lost, and the robust stability margins become the same for any chosen combination of indicator functions $\rho_F, \rho_G, \eta_F, \eta_G$. For the conditions from [BSC12], Theorem 2, null parameter variation is given by fixing $\Delta\theta = 0$, according to their notation. Finally, for the conditions from [Bar11a], Theorem 4.3, the time-invariant case is assessed by setting the indicator function $q = 1$. The results were displayed in the time-invariant (TI) portion of Table 2.2, showing either the same or better admissibility robust margins derived from our technique.

Time-varying systems subject to bounded rates of variation

In the time-varying context, parameters were allowed to vary in the consistent polytope $(w(k), \Delta w(k))$ with limits described in (2.12) for $b = [0.25; 0.5; 0.75; 1]$. The conditions presented in our Theorem 2.3.1 were tested for different configurations of the indicator functions $\rho_F, \rho_G, \eta_F, \eta_G$, according to Table 2.1:

i) $\rho_F = 1, \rho_G = 1, \eta_F = 1$ and $\eta_G = 1$, leading to matrices $F(w(k), w(k + 1))$ and $G(w(k), w(k + 1))$;

ii) $\rho_F = 1, \rho_G = 1, \eta_F = 0$ and $\eta_G = 0$, yielding matrices $F(w(k + 1))$ and $G(w(k + 1))$;

iii) $\rho_F = 0$ and $\rho_G = 0$ canceling the indicator functions η_F and η_G and hence the dependence on $w(k + 1)$, leading to matrices $F(w(k))$ and $G(w(k))$.

The condition in [BSC12], Theorem 2, was applied for the time-varying case on a consistent polytope. The conditions presented in [Bar11a], Theorem 4.3, apply only for arbitrary parameter variation, i.e. $b = 1$, what is done by setting the indicator function

TABLE 2.2: Robust admissibility margins κ for different analysis techniques

	b	Examples	Bex_2	RGS_1	RGS_2	RGS_3	
TI	0	Theorem 2.3.1 with $\rho_F = 1, \rho_G = 1, \eta_F = 1, \eta_G = 1$	1.399	2.629	2.5487	11.1746	
		Theorem 2.3.1 with $\rho_F = 1, \rho_G = 1, \eta_F = 0, \eta_G = 0$	1.399	2.629	2.5487	11.1746	
		Theorem 2.3.1 with $\rho_F = 0, \rho_G = 0$	1.399	2.629	2.5487	11.1746	
		[BSC12], Theorem 2	1.380	2.384	2.4697	10.2789	
		[Bar11a], Theorem 4.3	1.367	2.311	2.0672	9.5464	
TV	0.25	Theorem 2.3.1 with $\rho_F = 1, \rho_G = 1, \eta_F = 1, \eta_G = 1$	1.276	2.155	2.1437	9.4695	
		Theorem 2.3.1 with $\rho_F = 1, \rho_G = 1, \eta_F = 0, \eta_G = 0$	1.276	2.155	2.1426	9.4695	
		Theorem 2.3.1 with $\rho_F = 0, \rho_G = 0$	1.273	2.131	2.1358	9.3517	
		[BSC12], Theorem 2	1.239	2.110	2.1079	9.0246	
	0.5	Theorem 2.3.1 with $\rho_F = 1, \rho_G = 1, \eta_F = 1, \eta_G = 1$	1.128	1.984	1.9681	8.4206	
		Theorem 2.3.1 with $\rho_F = 1, \rho_G = 1, \eta_F = 0, \eta_G = 0$	1.127	1.984	1.9679	8.4206	
		Theorem 2.3.1 with $\rho_F = 0, \rho_G = 0$	1.124	1.960	1.9663	8.3217	
		[BSC12], Theorem 2	1.104	1.938	1.9528	8.0813	
	0.75	Theorem 2.3.1 with $\rho_F = 1, \rho_G = 1, \eta_F = 1, \eta_G = 1$	0.994	1.874	1.8416	7.7732	
		Theorem 2.3.1 with $\rho_F = 1, \rho_G = 1, \eta_F = 0, \eta_G = 0$	0.993	1.874	1.8414	7.7687	
		Theorem 2.3.1 with $\rho_F = 0, \rho_G = 0$	0.992	1.855	1.8410	7.7077	
		[BSC12], Theorem 2	0.988	1.829	1.8356	7.5225	
	1	1	Theorem 2.3.1 with $\rho_F = 1, \rho_G = 1, \eta_F = 1, \eta_G = 1$	0.929	1.812	1.7462	7.3895
			Theorem 2.3.1 with $\rho_F = 1, \rho_G = 1, \eta_F = 0, \eta_G = 0$	0.929	1.812	1.7462	7.3585
			Theorem 2.3.1 with $\rho_F = 0, \rho_G = 0$	0.928	1.795	1.7462	7.3754
			[BSC12], Theorem 2	0.927	1.758	1.7462	7.1964
[Bar11a], Theorem 4.3			0.927	1.737	1.7462	7.1897	

$q = 0$, according to her notation. The results on Table 2.2 shows that our technique can convey less restrictive results compared to [BSC12] and [Bar11a].

2.4 Conclusion

This chapter presents a contribution that was published in the proceeding of IFAC World Congress 2017 and is about new admissibility analysis conditions for discrete-time parameter-dependent polytopic descriptor systems. It uses parameter-dependent slack variables as well as the orthogonal complement of the derivative matrix E in order to achieve less conservative results. These new admissibility analysis conditions are expressed as a LMI feasibility problem and were obtained by exploiting the convexification technique of sums of polynomials. Numerical examples are proposed for both time-varying and time-invariant cases. They show that the proposed conditions can convey less restrictive results than the ones developed by [Bar11a; BSC12]. This comes from the more comprehensive structure chosen for the slack variables, along with the technique for eliminating the parametric dependence, namely sums of polynomials. Furthermore, a novel assumption was evoked for the stability of time-varying descriptor systems, being necessary for the convergence of the state vector as a whole.

As a future work, the presented admissibility conditions can be improved by incorporating different variation rates for each element of the parameter vector, and the implications of parameter dependence on the derivative matrix E can be evaluated.

Chapter 3

Extension of homogeneous polynomial Lyapunov functions approach to continuous-time uncertain descriptor systems

3.1 Introduction

The present chapter addresses the admissibility analysis of continuous-time uncertain descriptor systems subject to time-varying parameters. We recall that though quadratic Lyapunov functions provide necessary and sufficient conditions for the stability of LTI standard systems, they lead to conservative results for uncertain systems because they do not constitute a universal class for stability analysis (*cf.* Definition 1.2.14). Hence, results assessing the universality other classes of Lyapunov functions have been proposed in the literature for standard uncertain systems using polyhedral [BM95; BM08], piecewise quadratic and homogeneous polynomial functions [Che+03a; Che+07; Che11; Alt06].

Among these classes, the use of homogeneous polynomial Lyapunov functions (HPLFs) for stability analysis is highly advantageous since it can take profit of mathematical tools originally conceived for quadratic Lyapunov functions, as suggested by the form of the *square matricial representation* in Definition 1.2.21 and explicited through Remark 1.2.25, that explains the relation between a quadratic and a homogeneous polynomial Lyapunov function.

Although the use of homogeneous polynomial Lyapunov functions shows clear advantages, it still constitutes an open field of research. First, it is known that there exists a linear mapping between a standard uncertain system and its associated extended system (*cf.* Definition 1.2.24), but a formalized description of this mapping has not yet been proposed, as far as we know. Plus, there is no rule to set a maximum bound of the degree of HPLFs in order to obtain necessary and sufficient robust stability conditions for a time-varying parameter-dependent system. Besides, to the best of our knowledge, homogeneous polynomial Lyapunov functions have never been used in the more general framework of descriptor systems. This is mainly due to the fact

that, so far, it is completely unclear how the power transformations (Remark 1.2.20) shall be defined with regards to the dynamic and algebraic parts of the state vector.

Therefore, among the contributions of this chapter, we propose a description of the linear mapping between a standard uncertain system and its associated extended system. Then, a novel power transformation applied to the uncertain descriptor framework is defined, affecting dynamic and algebraic parts of the state vector differently and leading to a new extended descriptor system that remains linear with respect to the parameters. Thus, we are able to propose a novel description of the extended system for affine uncertain descriptor systems that is linear with respect to the uncertain parameters, and after, this extended system is used to elaborate new LMI admissibility analysis conditions by means of homogeneous polynomial Lyapunov functions for the original uncertain descriptor system. These results tend to fill the gap between the standard uncertain state-space systems and the uncertain descriptor ones by investigating the use of homogeneous polynomial Lyapunov functions for admissibility analysis purposes. Finally, numerical examples show that our new LMI-based robust admissibility analysis results are less restrictive than the ones using quadratic Lyapunov functions.

3.2 Affine parameter-dependent standard uncertain systems

In this section, we recall some concepts related to standard uncertain systems in order to introduce the first contribution of this chapter, namely a description of the mapping between a standard uncertain system and its extended version.

3.2.1 Class of systems and HPLF

Consider a continuous-time affine parameter-dependent uncertain system in the form (1.45):

$$\dot{x} = A(w(t))x = \left(A^{(0)} + \sum_{i=1}^m w_i(t)A^{(i)} \right) x, \quad (3.1)$$

where, as precised in Definition 1.2.4, the uncertain time-varying parameter vector $w(t) = [w_1(t) \dots w_m(t)]^T$ belongs to the convex set $w(t) \in \mathcal{W} = \text{Co}\{w^{(1)}, \dots, w^{(N)}\}$ where the vectors $w^{(i)}$, for $i = 1, \dots, N$, are given. As a consequence, the matrices $A_{ij}(w(t))$ also belong to convex sets whose N vertices are $A_{ij}(w^{(k)})$ for $k = 1, \dots, N$.

Concerning HPLFs, its properties can be found in section 1.2.3 and are here given:

- A HPLF of degree $2q$ is given, as shown in, by (1.67):

$$V_{2q}(x) = \sum_{i_1, \dots, i_n} p_{i_1 i_2 \dots i_n} x_1^{i_1} x_2^{i_2} \dots x_n^{i_n},$$

where $i_1, \dots, i_n \in \mathbb{Z}_{\geq 0}$ and $i_1 + i_2 + \dots + i_n = 2q$;

- (Definition 1.2.19) The base vector of homogeneous forms of degree q over the vector x is denoted as $x^{[q]}$, and $\dim(x^{[q]}) = d(n, q) = \frac{(n+q-1)!}{(n-1)!(q)!}$. The mapping between x and $x^{[q]}$ is called power transformation;
- (Definition 1.2.21) The square matrix representation associated to the Lyapunov function is $V_{2q}(x) = x^{[q]T} P x^{[q]}$. The matrix P is not unique, so a complete matrixial representation can take place in the form (1.83):

$$\begin{aligned} V_{2q}(x) &= x^{[q]T} P(\gamma) x^{[q]} = x^{[q]T} (P + P_0(\gamma)) x^{[q]} \\ &= x^{[q]T} \left(P + \sum_{i=1}^{d_{\mathcal{P}}(n,q)} \gamma_i P_{0i} \right) x^{[q]} \end{aligned}$$

where P_{0i} constitute a base of the linear space \mathcal{P} whose size is

$$d_{\mathcal{P}}(n, q) = \frac{1}{2} d(n, q)(d(n, q) + 1) - d(n, 2q);$$

- (Definition 1.2.24) The extended system associated to an affine uncertain system (3.1) is (1.85):

$$\frac{d}{dt} x^{[q]}(t) = A(w(t))_{[q]} x^{[q]}(t) = \left(A_{[q]}^{(0)} + \sum_{i=1}^m w_i(t) A_{[q]}^{(i)} \right) x^{[q]}(t). \quad (3.2)$$

Matrices $A_{[q]}^{(0)}$ and $A_{[q]}^{(i)}$, $i = 1, \dots, m$ are named as extended matrices of $A^{(0)}$ and $A^{(i)}$, respectively.

With these concepts in mind, we are able to introduce our description of the mapping between (3.1) and (3.2).

3.2.2 Linear mapping between the original and extended standard uncertain systems

It has been emphasized in the literature that there is a linear mapping between the entries of the dynamic matrices of the original and the extended systems [JW01]. This fact is also sustained by the following lemma.

Lemma 3.2.1: [BSP16] There exist matrices M_i, N_i , for $i = 1, \dots, d(n, q-1)$, such that the extended matrix $A(w(t))_{[q]}$ is given by

$$A(w(t))_{[q]} = \sum_{i=1}^{d(n,q-1)} M_i A(w(t)) N_i, \quad (3.3)$$

where $d(n, q-1) = \dim(x^{[q-1]}) = \frac{(n+q-2)!}{(n-1)!(q-1)!}$, and $M_i \in \mathbb{R}^{d(n,q) \times n}$, $N_i \in \mathbb{R}^{n \times d(n,q)}$ are constant matrices. Matrices N_i are such that $x_i^{[q-1]}x = N_i x^{[q]}$ and matrices M_i are given by $M_i = \frac{d\left(\frac{\partial x^{[q]}}{\partial x}\right)}{dx_i^{[q-1]}}$.

Proof. The extended matrix definition (Definition 1.2.23) involves the term $\frac{\partial x^{[q]}}{\partial x}$ which is the jacobian matrix of $x^{[q]}$. Each (l, j) -entry of this matrix is given by $\frac{\partial x_l^{[q]}}{\partial x_j} = i_j x_1^{i_1} \dots x_j^{i_j-1} \dots x_n^{i_n}$, where $i_k > 0$, $k = 1, \dots, n$ and $\sum_{k=1}^n i_k = q$. This means that each entry of the jacobian matrix is proportional to a monomial of degree $q-1$ of x . Therefore, using the definitions of M_i and N_i given in the formulation of the lemma and since there are $d(n, q-1) = \dim(x^{[q-1]})$ monomials of degree $q-1$ of x , the jacobian matrix of $x^{[q]}$ is given by $\frac{\partial x^{[q]}}{\partial x} = \sum_{i=1}^{d(n,q-1)} M_i x_i^{[q-1]}$. This implies that the dynamic of the extended system is defined by:

$$\dot{x}^{[q]}(t) = \sum_{i=1}^{d(n,q-1)} M_i x_i^{[q-1]} A(w(t))x = \sum_{i=1}^{d(n,q-1)} M_i A(w(t))x_i^{[q-1]}x.$$

Since the entries of $x^{[q-1]}x$ are monomials of degree q of x there exist constant unique matrices $N_i \in \mathbb{R}^{n \times d(n,q)}$ such that $x_i^{[q-1]}x = N_i x^{[q]}$. This yields the form (3.3) for the extended matrix $A(w(t))_{[q]}$. \square

Matrices M_i and N_i depend only on the choice of the base vector $x^{[q]}$ of homogeneous forms of degree q . In general, this vector is chosen in lexicographical order. Examples of matrices M_i , N_i for different matrix dimensions n and degrees q are given below.

Example 3.2.1. Consider a parameter-dependent system (3.1) where $\dim(x) = n = 2$ and $A(w(t)) = \begin{bmatrix} a_{11}(w(t)) & a_{12}(w(t)) \\ a_{21}(w(t)) & a_{22}(w(t)) \end{bmatrix}$. We deploy the dimensions and the matrices of the mapping M_i , N_i , $i = 1, \dots, d(n, q-1)$ for power transformations of different degrees below:

- Choice of power transformation of degree $q = 2$: We obtain $d(n, q) = 3$ and $d(n, q-1) = 2$. The power transformation of degree 2 of x is $x^{[2]} = \begin{bmatrix} x_1^2 & x_1 x_2 & x_2^2 \end{bmatrix}^T$ and the extended state matrix is

$$A_{[2]}(w(t)) = \begin{bmatrix} 2a_{11}(w(t)) & 2a_{12}(w(t)) & 0 \\ a_{21}(w(t)) & a_{11}(w(t)) + a_{22}(w(t)) & a_{12}(w(t)) \\ 0 & 2a_{21}(w(t)) & 2a_{22}(w(t)) \end{bmatrix}.$$

Lemma 3.2.1 holds with

$$\left[M_1 \mid M_2 \right] = \left[\begin{array}{cc|cc} 2 & 0 & 0 & 0 \\ 0 & 1 & 1 & 0 \\ 0 & 0 & 0 & 2 \end{array} \right], \quad \left[\begin{array}{c} N_1 \\ N_2 \end{array} \right] = \left[\begin{array}{ccc} 1 & 0 & 0 \\ 0 & 1 & 0 \\ 0 & 1 & 0 \\ 0 & 0 & 1 \end{array} \right].$$

- Choice of power transformation of degree $q = 3$: We have $d(n, q) = 4$ and $d(n, q - 1) = 3$. The power transformation of degree 3 of x is $x^{[3]} = [x_1^3 \ x_1^2 x_2 \ x_1 x_2^2 \ x_2^3]^T$ and the extended matrix is

$$A_{[3]}(w(t)) = \left[\begin{array}{cccc} 3a_{11}(w(t)) & 3a_{12}(w(t)) & 0 & 0 \\ a_{21}(w(t)) & 2a_{11}(w(t)) + a_{22}(w(t)) & 2a_{12}(w(t)) & 0 \\ 0 & 2a_{21}(w(t)) & a_{11}(w(t)) + 2a_{22}(w(t)) & a_{12}(w(t)) \\ 0 & 0 & 3a_{21}(w(t)) & 3a_{22}(w(t)) \end{array} \right].$$

Matrices M_i and N_i in Lemma 3.2.1 are given by

$$\left[\begin{array}{c} M_1^T \\ M_2^T \\ M_3^T \end{array} \right] = \left[\begin{array}{cccc} 3 & 0 & 0 & 0 \\ 0 & 1 & 0 & 0 \\ 0 & 2 & 0 & 0 \\ 0 & 0 & 2 & 0 \\ 0 & 0 & 1 & 0 \\ 0 & 0 & 0 & 3 \end{array} \right] \quad \text{and} \quad \left[\begin{array}{c} N_1 \\ N_2 \\ N_3 \end{array} \right] = \left[\begin{array}{cccc} 1 & 0 & 0 & 0 \\ 0 & 1 & 0 & 0 \\ 0 & 1 & 0 & 0 \\ 0 & 0 & 1 & 0 \\ 0 & 0 & 1 & 0 \\ 0 & 0 & 0 & 1 \end{array} \right].$$

Example 3.2.2. Consider now a parameter-dependent descriptor system (3.1) where $\dim(x) = n = 3$ and

$$A(w(t)) = \left[\begin{array}{ccc} a_{11}(w(t)) & a_{12}(w(t)) & a_{13}(w(t)) \\ a_{21}(w(t)) & a_{22}(w(t)) & a_{23}(w(t)) \\ a_{31}(w(t)) & a_{32}(w(t)) & a_{33}(w(t)) \end{array} \right].$$

The dimensions and the matrices of the mapping $M_i, N_i, i = 1, \dots, d(n, q - 1)$ for power transformations of different degrees are found in the following:

- Choice of power transformation of degree $q = 2$: We obtain $d(n, q) = 6$, $d(n, q - 1) = 3$, $x^{[2]} = [x_1^2 \ x_1 x_2 \ x_1 x_3 \ x_2^2 \ x_2 x_3 \ x_3^2]^T$ and $A_{[2]}$ extended matrix is

$$A_{[2]}(w(t)) = \left[\begin{array}{ccc} 2a_{11}(w(t)) & 2a_{12}(w(t)) & 2a_{13}(w(t)) \\ a_{21}(w(t)) & a_{11}(w(t)) + a_{22}(w(t)) & a_{23}(w(t)) \\ a_{31}(w(t)) & a_{32}(w(t)) & a_{11}(w(t)) + a_{33}(w(t)) \\ 0 & 2a_{21}(w(t)) & 0 \\ 0 & a_{31}(w(t)) & a_{21}(w(t)) \\ 0 & 0 & 2a_{31}(w(t)) \end{array} \right]$$

$$\begin{bmatrix} 0 & 0 & 0 \\ a_{12}(w(t)) & a_{13}(w(t)) & 0 \\ 0 & a_{12}(w(t)) & a_{13}(w(t)) \\ 2a_{22}(w(t)) & 2a_{23}(w(t)) & 0 \\ a_{32}(w(t)) & a_{22}(w(t)) + a_{33}(w(t)) & a_{23}(w(t)) \\ 0 & 2a_{32}(w(t)) & 2a_{33}(w(t)) \end{bmatrix}.$$

Therefore, Lemma 3.2.1 holds with

$$\begin{bmatrix} M_1 & | & M_2 & | & M_3 \end{bmatrix} = \begin{bmatrix} 2 & 0 & 0 & | & 0 & 0 & 0 & | & 0 & 0 & 0 \\ 0 & 1 & 0 & | & 1 & 0 & 0 & | & 0 & 0 & 0 \\ 0 & 0 & 1 & | & 0 & 0 & 0 & | & 1 & 0 & 0 \\ 0 & 0 & 0 & | & 0 & 2 & 0 & | & 0 & 0 & 0 \\ 0 & 0 & 0 & | & 0 & 0 & 1 & | & 0 & 1 & 0 \\ 0 & 0 & 0 & | & 0 & 0 & 0 & | & 0 & 0 & 2 \end{bmatrix},$$

$$\begin{bmatrix} N_1^T & | & N_2^T & | & N_3^T \end{bmatrix} = \begin{bmatrix} 1 & 0 & 0 & | & 0 & 0 & 0 & | & 0 & 0 & 0 \\ 0 & 1 & 0 & | & 1 & 0 & 0 & | & 0 & 0 & 0 \\ 0 & 0 & 1 & | & 0 & 0 & 0 & | & 1 & 0 & 0 \\ 0 & 0 & 0 & | & 0 & 1 & 0 & | & 0 & 0 & 0 \\ 0 & 0 & 0 & | & 0 & 0 & 1 & | & 0 & 1 & 0 \\ 0 & 0 & 0 & | & 0 & 0 & 0 & | & 0 & 0 & 1 \end{bmatrix}.$$

Remark 3.2.2 (Parameter dependence in the extended system). *Note that, for a standard affine/polytopic parameter-dependent system with time-varying parameters, the entries of the extended dynamic matrix generated by the use of power transformations are linear with respect to the coefficients of the original dynamic matrix and therefore affine with respect to uncertain parameters. This property can be exploited in order to reduce the infinite set of robust stability analysis conditions to a finite one involving the vertices of the uncertainties polytope.*

The characterization proposed in the previous lemma is fundamental for the contributions of the ensuing section, that no longer deals with standard uncertain systems, but with the uncertain descriptor case.

3.3 Affine parameter-dependent descriptor systems

In this section, concepts about the class of affine parameter-dependent descriptor systems are recalled and novel admissibility analysis conditions are provided for such systems by means of parameter-independent HPLFs. Furthermore, a power transformation for descriptor systems state vectors is proposed. Numerical examples give some insight on the relevance of the results.

3.3.1 Class of systems

Consider an affine parameter-dependent descriptor system in section 1.3.4 in the SVD normal form (1.92):

$$\dot{x}(t) = A_{11}(w(t))x(t) + A_{12}(w(t))\zeta(t) \quad (3.4a)$$

$$0^{n_\xi \times 1} = A_{21}(w(t))x(t) + A_{22}(w(t))\zeta(t). \quad (3.4b)$$

Matrices $A_{ij}(w(t))$ are affine according to the uncertain parameters and given by

$$A_{ij}(w(t)) = A_{ij}^{(0)} + \sum_{k=1}^m w_k(t)A_{ij}^{(k)} \quad (3.5)$$

where $A_{22}(w(t))$ is square and $A_{ij}^{(k)}$, for $i = 1, 2, j = 1, 2, k = 1, \dots, m$, are given matrices. The characteristics of the parameter space are given in Definition 1.2.4 and recalled in the previous section 3.2.1. Likewise, matrices $A_{ij}(w(t))$ also belong to convex sets with N vertices given as $A_{ij}(w^{(k)})$ for $k = 1, \dots, N$.

From section 1.3.2, we have that any time-varying descriptor system $E\dot{X}(t) = A(t)X(t)$, where $\text{rank}(E) = n \leq n + n_\xi$ and $\dim(X) = n + n_\xi$, can be rewritten in the SVD normal form (3.4) through a change of coordinates whenever E is a constant matrix. Important properties for uncertain descriptor systems, such as regularity, absence of impulse modes, stability of finite modes and admissibility are detailed in section 1.3.3.

3.3.2 Parameter-independent homogeneous polynomial Lyapunov functions

This section presents one of our main contributions in the context of this thesis, that is the extension of the homogeneous polynomial Lyapunov function approach, previously developed only for standard state-space systems, to the more general case of uncertain descriptor time-varying systems. As far as we know, the power transformations have never been used in the context of uncertain descriptor systems, and there is no available literature defining how the dynamic and the algebraic parts of the original state vector should compose the extended state vector.

For evaluating the admissibility of the uncertain descriptor system (3.4) using homogeneous polynomial Lyapunov functions, one could try to rewrite it according to the equivalent standard form as stated in Remark 1.3.4, and then, employ the power transformations to study the stability of this equivalent standard system. However, this procedure leads to an augmented system whose state matrix entries are nonlinear functions of the entries of matrices $A_{ij}(w(t))$, $i = 1, 2, j = 1, 2$, producing nonlinear couplings between the uncertain parameters.

In the following, we provide a new technique circumventing this nonlinearity problem by exploiting the equivalent standard form while preserving the affine dependence property. The lemma and theorem below aim to fill the gap between the

standard state-space systems and the descriptor systems by extending the HPLF approach to the context of descriptor systems.

Lemma 3.3.1 ([SPB17a]): The uncertain descriptor system (3.4) is robustly admissible with a HPLF of degree $2q$ if and only if the extended descriptor system

$$\mathcal{E} \begin{bmatrix} \frac{d}{dt} x^{[q]}(t) \\ \frac{d}{dt} (x^{[q-1]}(t) \otimes \zeta(t)) \end{bmatrix} = \begin{bmatrix} A_{11_{[q]}}(w(t)) & M_1 A_{12}(w(t)) & M_2 A_{12}(w(t)) & \dots & M_{d(n,q-1)} A_{12}(w(t)) \\ A_{21}(w(t)) N_1 & A_{22}(w(t)) & & & \\ A_{21}(w(t)) N_2 & & A_{22}(w(t)) & & \\ \vdots & & & \ddots & \\ A_{21}(w(t)) N_{d(n,q-1)} & & & & A_{22}(w(t)) \end{bmatrix} \begin{bmatrix} x^{[q]}(t) \\ x^{[q-1]}(t) \otimes \zeta(t) \end{bmatrix} \quad (3.6)$$

is robustly admissible with a quadratic Lyapunov function. In (3.6), $\mathcal{E} = B \text{diag}(I_{d(n,q)}, 0_{d(n,q-1)n_\zeta})$, $M_i \in \mathbb{R}^{d(n,q) \times n}$, $N_i \in \mathbb{R}^{n \times d(n,q)}$, $i = 1, \dots, d(n, q-1)$ are given according to Lemma 3.2.1.

Proof. As presented in section Remark 1.3.4, the uncertain descriptor system (3.4) is robustly admissible if and only if $A_{22}(w(t))$ matrix is invertible for all possible values of the parameter vector $w(t) \in \mathcal{W}$ and the following equivalent standard state-space system

$$\dot{x}(t) = \Gamma(w(t))x(t), \quad (3.7)$$

where the matrix $\Gamma(w(t))$ defined as

$$\Gamma(w(t)) = A_{11}(w(t)) - A_{12}(w(t))A_{22}(w(t))^{-1}A_{21}(w(t)),$$

is stable for all possible uncertain parameters trajectories $w(t) \in \mathcal{W}$. In order to ensure the stability of this standard system, we employ HPLFs of degree $2q$. Therefore, the extended system obtained by applying a power transformation of degree q on the state vector x of system (3.7) is given, according to Definition 1.2.24, by

$$\dot{x}^{[q]}(t) = \Gamma_{[q]}(w(t))x^{[q]}(t). \quad (3.8)$$

The HPLFs-based stability of system (3.7) is guaranteed whenever the extended system (3.8) is quadratically stable. Using Lemma 3.2.1, it follows that there exist matrices M_i, N_i , for $i = 1, \dots, d(n, q-1)$, such that this extended system state-matrix rewrites

$$\begin{aligned} \Gamma_{[q]}(w(t)) &= \sum_{i=1}^{d(n,q-1)} M_i \Gamma(w(t)) N_i \\ &= \sum_{i=1}^{d(n,q-1)} M_i A_{11}(w(t)) N_i - \sum_{i=1}^{d(n,q-1)} M_i A_{12}(w(t)) A_{22}^{-1}(w(t)) A_{21}(w(t)) N_i. \end{aligned}$$

The first sum of the right-hand expression represents the extended matrix $A_{11_{[q]}}(w(t))$ throughout Lemma 3.2.1. Using the Schur lemma, and exploiting the same Lemma 3.2.1, it follows that the quadratic stability of the extended system (3.8) for all possible uncertain parameters trajectories $w(t) \in \mathcal{W}$ and the invertibility of $A_{22}(w(t))$ matrix for all possible uncertain parameters trajectories $w(t) \in \mathcal{W}$ is equivalent to the robust admissibility (cf. section 1.3.3) of the extended descriptor system (3.6) based on quadratic Lyapunov functions. \square

Remark 3.3.2. *The application of a power transformation of degree q over the equivalent standard state-space system (3.7) leads to the extended descriptor system (3.6) with the associated state vector $\begin{bmatrix} x^{[q]} \\ x^{[q-1]} \otimes \xi \end{bmatrix}$. This extended state vector is homogeneous of degree q but it does not involve all the possible monomials of degree q of the vector $\begin{bmatrix} x \\ \xi \end{bmatrix}$. The upper part of this extended state vector, $x^{[q]}$, represents the power transformation of degree q of the dynamic state x of the original descriptor system (1.88) while the lower part, $x^{[q-1]} \otimes \xi$, represents the algebraic state of the extended descriptor system. This algebraic part of the extended descriptor system is homogeneous of degree q and involves products between the algebraic state variables ξ of the original system and all the monomials of degree $q - 1$ of the dynamic state x of the original system (1.88).*

From now on, we refer to equation (3.6) with the compact notation

$$\mathcal{E} \begin{bmatrix} \frac{d}{dt} x^{[q]}(t) \\ \frac{d}{dt} (x^{[q-1]}(t) \otimes \xi(t)) \end{bmatrix} = \mathcal{A}_{\{q\}}(w(t)) \begin{bmatrix} x^{[q]}(t) \\ x^{[q-1]}(t) \otimes \xi(t) \end{bmatrix}. \quad (3.9)$$

Note that the extended descriptor system (3.6) is affine with respect to the uncertain parameters. This property allows to formulate new LMI admissibility conditions for affine parameter-dependent continuous-time descriptor systems based on HPLFs as stated in the following theorem.

Theorem 3.3.3 ([SPB17a]). *The time-varying parameter-dependent descriptor system (3.4) is robustly admissible based on HPLFs if there exist a bloc-partitioned matrix $P = \begin{bmatrix} P_{11} & 0 \\ P_{21} & P_{22} \end{bmatrix}$, where $P_{11} \in \mathbf{R}^{d(n,q) \times d(n,q)}$, $P_{21} \in \mathbf{R}^{d(n,q-1) \cdot n_{\xi} \times d(n,q)}$ and $P_{22} \in \mathbf{R}^{d(n,q-1) \cdot n_{\xi} \times d(n,q-1) \cdot n_{\xi}}$, and scalars γ_{ij} , $i = 1, \dots, N$, $j = 1, \dots, d_{\mathcal{P}}(n, q)$, satisfying the following LMI conditions:*

$$\begin{aligned} & P_{11} > 0, \\ & \mathcal{A}_{\{q\}}(w^{(i)})^T P + P \mathcal{A}_{\{q\}}(w^{(i)}) + \sum_{j=1}^{d_{\mathcal{P}}(n,q)} \gamma_{ij} \begin{bmatrix} P_{0j} & \\ & 0 \end{bmatrix} < 0, \\ & i = 1, \dots, N \end{aligned}$$

where $w^{(i)}$ are the vertices of \mathcal{W} and matrices P_{0j} are a base of the linear space \mathcal{P} .

Proof. The LMI conditions of this theorem derive from the strict LMI admissibility conditions proposed in [IT02]. In fact, the work [IT02] showed that a descriptor system $E\dot{X} = AX$ is admissible if and only if there exist a positive-definite matrix \bar{P} and a general matrix \bar{Q} such that $\mathcal{H}e(A^T(\bar{P}E + E_0\bar{Q})) < 0$ where E_0 is such that $E^T E_0 = 0$. Whenever the system is in the SVD form, *i.e.* $E = B \text{diag}(I_n, 0_{n_\xi})$, then $E_0 = \begin{bmatrix} 0_{n_\xi \times n} & I_{n_\xi} \end{bmatrix}^T$ and one can easily prove that this necessary and sufficient condition is equivalent to the existence of a block-partitioned matrix $P = \begin{bmatrix} P_{11} & 0 \\ P_{21} & P_{22} \end{bmatrix}$ such that $P_{11} > 0$ and $A^T P + PA < 0$. Therefore, the use of a triangular structure in P is not restrictive, because the degree of freedom given by the use of \bar{Q} in [IT02] is embedded in the submatrices P_{21} and P_{22} .

This result generalizes to affine parameter-dependent systems by using the convexity principle. Therefore, the application of this generalization to the extended descriptor system (3.6), that is affine with respect to the parameters, leads to the LMI admissibility conditions of our theorem with $\gamma_{ij} = 0$.

The Lyapunov function ensuring the robust admissibility of the extended descriptor system (3.6) is

$$V_{2q} = \begin{bmatrix} x^{[q]}(t) \\ x^{[q-1]}(t) \otimes \xi(t) \end{bmatrix}^T \mathcal{E}^T P \begin{bmatrix} x^{[q]}(t) \\ x^{[q-1]}(t) \otimes \xi(t) \end{bmatrix}. \quad (3.10)$$

Considering the block structure of the matrix P and the definition of \mathcal{E} in (3.6), it follows that $V_{2q} = x^{[q]T}(t)P_{11}x^{[q]}(t)$. As mentioned in Definition 1.2.21, the use of HPLFs generates the nonuniqueness of the matrix P associated to the SMR representation. Therefore, the complete parameterization $P_0(\gamma)$ of the linear space \mathcal{P} associated to P_{11} may be added in order to introduce complementary degrees of freedom leading to less conservative results for the admissibility analysis problem. Different parameterizations for each vertex of the parameters domain \mathcal{W} are obtained for $\gamma_{ij} \neq 0$. \square

The next section shows that the HPLF approach extended to uncertain time-varying descriptor systems allows to obtain less restrictive results than the ones based on quadratic Lyapunov functions.

3.3.3 Numerical examples

The following examples illustrate the interest of using HPLFs for assessing robust admissibility margins for uncertain descriptor systems. For the comparison, we use the following metrics:

Definition 3.3.4 ($\kappa_{2q\Box}^*$ admissibility margins): The ℓ_∞ $2q$ -HPLF asymmetric and symmetric admissibility margins with respect to the perturbation set, respectively κ_{2q+}^*

and $\kappa_{2q|\cdot|}^*$, are defined as:

$$\begin{aligned}\kappa_{2q\Box}^* &= \sup\{\kappa : \exists V_{2q} \text{ for (3.4), } w(t) \in \bar{\mathcal{B}}_{\kappa\Box}, \Box = \{+, |\cdot|\}\}, \\ \bar{\mathcal{B}}_{\kappa+} &= \{b \in R^m : 0 \leq b_i \leq \kappa, i = 1, \dots, m\}, \\ \bar{\mathcal{B}}_{\kappa|\cdot|} &= \{b \in R^m : |b_i| \leq \kappa, i = 1, \dots, m\}.\end{aligned}$$

These robust admissibility margins are based on [Che+03a], and are applied here for robust admissibility analysis purposes.

Example 1

Consider the parameter-dependent descriptor system

$$E \begin{bmatrix} \dot{x}(t) \\ \dot{\zeta}(t) \end{bmatrix} = A(w(t)) \begin{bmatrix} x(t) \\ \zeta(t) \end{bmatrix}, \quad (3.11)$$

where $x(t) \in R^3$, $\zeta(t) \in R$, $E = Bdiag(I_3, 0)$, and $A(w(t)) = A^{(0)} + w(t)A^{(1)}$, with

$$A^{(0)} = \begin{bmatrix} 0 & 1 & 0 & 0.5 \\ 0 & 0 & 1 & 1 \\ -1 & -2 & -4 & 0 \\ 1 & 0 & 0 & 1 \end{bmatrix}, \quad A^{(1)} = \begin{bmatrix} -2 & 0 & -1 & 0 \\ 1 & -10 & 3 & 1 \\ 3 & -4 & 2 & 0 \\ -1 & 0 & 0 & 0.2 \end{bmatrix}.$$

Since $m = 1$, the set \mathcal{W} has $N = 2^1$ vertices given by $w^{(1)} = 0$ and $w^{(2)} = \kappa$. For HPLFs of degree 4 ($q = 2$), the vector $x^{[2]}$ in lexicographical order is given by $[x_1^2 \ x_1x_2 \ x_1x_3 \ x_2^2 \ x_2x_3 \ x_3^2]^T$. The dimension of the linear space \mathcal{P} is $d_{\mathcal{P}}(n, q) = 6$ and the parameterization of the HPLF is

$$P_0(\gamma) = \begin{bmatrix} 0 & 0 & 0 & -\gamma_1 & -\gamma_2 & -\gamma_3 \\ 0 & 2\gamma_1 & \gamma_2 & 0 & -\gamma_4 & -\gamma_5 \\ 0 & \gamma_2 & 2\gamma_3 & \gamma_4 & \gamma_5 & 0 \\ -\gamma_1 & 0 & \gamma_4 & 0 & 0 & -\gamma_6 \\ -\gamma_2 & -\gamma_4 & \gamma_5 & 0 & 2\gamma_6 & 0 \\ -\gamma_3 & -\gamma_5 & 0 & -\gamma_6 & 0 & 0 \end{bmatrix}.$$

The matrices M_i and N_i for this system are described in Lemma 3.2.1. Their numerical values and the vector $x^{[2]}$ are indicated in Example 3.2.2 of the same Lemma. Using HPLFs of degree 4 throughout the application of our criteria stated in Theorem 3.3.3 guarantees an admissibility margin $\kappa_{4+}^* = 16.3943$, while for a quadratic Lyapunov function one finds $\kappa_{2+}^* = 4.6667$. This shows an important improvement of the ℓ_{∞} $2q$ -HPLF positive admissibility margin when using the HPLF approach here given.

Example 2

Consider the parameter-dependent descriptor system given by (3.11), with $x(t) \in \mathbb{R}^2$, $\zeta(t) \in \mathbb{R}$, $E = \text{Bdiag}(I_2, 0)$, and $A(w(t)) = A^{(0)} + w(t)A^{(1)}$,

$$A^{(0)} = \begin{bmatrix} 0 & 1 & 0.2 \\ -6 & -1 & 0 \\ 0.1 & 0.2 & 1 \end{bmatrix}, \quad A^{(1)} = \begin{bmatrix} 0 & 0 & 0 \\ -1 & 0 & 0 \\ 0 & 0 & 0.1 \end{bmatrix}.$$

Since $m = 1$, the set \mathcal{W} has $N = 2^1$ vertices given by $w^{(1)} = -\kappa$ and $w^{(2)} = \kappa$. For different degrees $2q$ of the HPLF, the obtained values of $\kappa_{2q|\cdot}^*$ are provided in Table 3.1, showing progressive improvements of the robust admissibility margins for higher values of q .

TABLE 3.1: $\kappa_{2q|\cdot}^*$ obtained for Example 2

$2q$	2	4	6	8	10	12	14
$\kappa_{2q \cdot}^*$	2.5726	3.4510	3.6506	3.7157	3.8170	3.8205	3.8660

3.4 Conclusion

The present chapter provides new LMI admissibility analysis conditions for time-varying parameter-dependent continuous-time descriptor systems. The results here presented tend to fill the gap between the uncertain standard state-space systems and the uncertain descriptor ones by investigating the use of homogeneous polynomial Lyapunov functions for admissibility analysis purposes. This has been achieved by using a new power transformation of the state vector that takes into account its dynamic and algebraic parts differently. Numerical examples show that the use of power transformations of higher degrees may lead to less conservative results.

Chapter 4

Admissibility analysis of continuous-time uncertain descriptor systems by parameter-dependent homogeneous polynomial Lyapunov functions

4.1 Introduction

In the previous chapter, conditions for the admissibility analysis of continuous-time affine parameter-dependent descriptor systems were provided. There, the analysis results hold for arbitrary parameters' rates of variation, what is particularly important for the cases in which there is no knowledge available about the parameters' velocities or when parameters can vary instantaneously, such as in the context of switched systems.

However, in [OP08] it is evoked that many systems contain parameters with bounds in their variation, and by experience and observation, we remark that, for certain systems, parameters such as the temperature cannot change instantaneously. Therefore, when knowledge about the limits of parameters' velocities is available, the use of this information can lead to less conservative results.

In this chapter, we present admissibility analysis conditions for continuous-time polytopic parameter-dependent descriptor systems. The system parameters' velocities are considered to be bound, and this information is incorporated in the analysis criteria through the use of parameter-dependent homogeneous polynomial Lyapunov functions.

For proceeding with the extension of the scope of applications of homogeneous polynomial Lyapunov functions, the chapter has been structured with the introduction of the class of systems of interest, followed by the presentation of admissibility conditions based upon the existence of parameter-dependent homogeneous polynomial Lyapunov functions. Two functions are given: one with dependence of degree

one in the uncertain parameter vector, and the other, with dependence of arbitrary degree in the parameters. Numerically tractable sufficient conditions are obtained through different convexification techniques and compared with the use of numerical examples.

4.2 Polytopic uncertain descriptor systems

In this first section, we introduce the class of systems we address, namely the continuous-time polytopic parameter-dependent descriptor systems, and we characterize the parameter variation space.

4.2.1 Class of systems

Consider a parameter-dependent descriptor system in the SVD normal form (1.92):

$$\dot{x}(t) = A_{11}(w(t))x(t) + A_{12}(w(t))\bar{\zeta}(t) \quad (4.1a)$$

$$0^{n_\xi \times 1} = A_{21}(w(t))x(t) + A_{22}(w(t))\bar{\zeta}(t). \quad (4.1b)$$

In such form, matrices $A_{ij}(w(t))$, $i = 1, 2$, $j = 1, 2$ have polytopic parameter dependence, so that

$$A_{ij}(w(t)) = \sum_{k=1}^N w_k(t) A_{ij}^{(k)}. \quad (4.2)$$

Recalling Definition 1.2.6, the parameter w lies in the unit simplex and the matrices $A_{ij}(w(t))$ are also described within polytopes of matrices.

Considerations about the SVD normal form for uncertain descriptor systems can be found in section 1.3.2, properties of uncertain descriptor systems, such as admissibility, are found in section 1.3.3, and information about HPLFs can be retrieved in section 1.2.5. In addition, we define the following matrix space that regroups the set of realizations of the linear space \mathcal{P} (cf. Definition 1.2.21):

$$\mathcal{U} = \{P_0(\gamma) \in \mathbb{R}^{d(n,q) \times d(n,q)} \mid P_0(\gamma) = \sum_{i=1}^{d_{\mathcal{P}}(n,q)} \gamma_i P_{0i} \text{ with } \gamma_i \in \mathbb{R} \text{ and } P_{0i} \in \mathcal{P}\}. \quad (4.3)$$

Given that we are working with time-varying parameters subject to bounded velocities, a characterization of the space of parameters' variations is necessary. This is done in the following section.

4.2.2 Parameters' variation space

Recalling section 1.2.2, the characterization of the space of parameters' variations is not a simple task because there are algebraic constraints to be satisfied and, eventually, the shape of this space can be time-varying. In Chapter 2, we explored a description proposed in [OP08], and here we employ a characterization given in [GC06].

Polytopic parameters belong to the set \mathcal{W} , as

$$w(t) \in \mathcal{W} = \{w \in \mathbb{R}^N \mid \sum_{i=1}^N w_i = 1, 0 \leq w_i \leq 1\} \forall t \geq 0.$$

A natural consequence of the parameter description $w(t) \in \mathcal{W}$ over the velocities of parameters $\dot{w}(t)$ is that $\sum_{i=1}^N \dot{w}_i(t) = 0$ must always hold true. Accordingly to the formulation of [GC06; Che+07], the set of admissible parameters is $w(t) \in \mathcal{W}$ and $\dot{w}(t) \in \mathcal{V} \forall t \geq 0$ as (1.54):

$$\mathcal{V} = \{v \in \mathbb{R}^N, v \in \text{Co}(g^1, \dots, g^h) \mid \sum_{i=1}^N g_i^j = 0, j = 1 \dots h\},$$

and $\|g^j\|_\infty \leq \beta, j = 1 \dots h$ holds.

As an example, consider the case $N = 2$, where velocities are bound by a scalar β : $|\dot{w}(t)| \leq \beta$. The set of admissible parameters is given by $w(t) = [w_1(t) \ w_2(t)]^T \in \mathcal{W}$ and parameters' velocities are such that $\dot{w}(t) \in \mathcal{V}, h = 2$ and $\{g^1, g^2\} = \left\{ \begin{bmatrix} \beta \\ -\beta \end{bmatrix}, \begin{bmatrix} -\beta \\ \beta \end{bmatrix} \right\}$.

The fact that $\dot{w}(t) \in \mathcal{V}$ allows us to employ the following polytopic notation:

$$\dot{w}(t) = \sum_{j=1}^h \sigma_j(t) g^j, \sigma(t) \in \mathcal{W} \forall t \geq 0. \quad (4.4)$$

4.3 Admissibility analysis based on polytopic HPLFs

In this section, we propose new admissibility analysis conditions for uncertain descriptor systems subject to parameters with bounded velocities by means of Lyapunov functions that are homogeneous polynomial in the states and polytopic-dependent in the uncertain parameters as defined below.

Definition 4.3.1 (Polytopic parameter-dependent HPLFs - PPD-HPLFs [SPB18a]): A polytopic parameter-dependent HPLF (PPD-HPLF) of degree $2q$ for the uncertain system (4.1) is given by:

$$V_{2q} = \begin{bmatrix} x^{[q]}(t) \\ x^{[q-1]}(t) \otimes \zeta(t) \end{bmatrix}^T \mathcal{E}^T P(w(t)) \mathcal{E} \begin{bmatrix} x^{[q]}(t) \\ x^{[q-1]}(t) \otimes \zeta(t) \end{bmatrix}, \quad (4.5)$$

where the Lyapunov matrix is given as $P(w(t)) = \sum_{i=1}^N w_i(t) P^{(i)}$,

$P^{(i)} \in \mathbb{R}^{(d(n,q)+d(n,q-1)*n_\zeta) \times (d(n,q)+d(n,q-1)*n_\zeta)}$, $i = 1, \dots, N$. Parameters are defined as $w(t) \in \mathcal{W}$ and $\dot{w}(t) \in \mathcal{V}$. The matrix \mathcal{E} comes from the extended descriptor system associated to (4.1), in accordance with the notation of (3.9).

Remark 4.3.2. Note that the polytopic definition of $P(w(t))$ and $\dot{w}(t) \in \mathcal{V}$ given in (4.4) can be employed in the definition of $P(\dot{w}(t))$ as follows:

$$P(\dot{w}(t)) = \sum_{i=1}^N \dot{w}_i(t) P^{(i)} = \sum_{i=1}^N \sum_{j=1}^h \sigma_j(t) g_i^j P^{(i)} = \sum_{j=1}^h \sigma_j(t) \underbrace{\sum_{i=1}^N g_i^j P^{(i)}}_{=P(g^j)}. \quad (4.6)$$

Remark 4.3.3. In the work [BSC13, Theorem 1], some necessary and sufficient conditions for the admissibility analysis of LTV descriptor systems have been presented. Note that these conditions are necessary and sufficient only for the existence of a quadratic Lyapunov function. In the present chapter, we assess the admissibility of a parameter-dependent system by providing necessary and sufficient conditions for the existence of Lyapunov functions belonging to a larger class, namely the class of homogeneous polynomial Lyapunov functions. This class of Lyapunov functions is universal for uncertain systems, and its use might lead to less conservative robust admissibility margins.

Lemma 4.3.4 ([SPB18a]): The polytopic uncertain descriptor system (4.1) subject to time-varying parameters with bounded rates of variation is robustly admissible with a PPD-HPLF if and only if there exist matrices $P(w(t))$, $F(w(t))$ and $G(w(t)) \in \mathbb{R}^{(d(n,q)+d(n,q-1) \cdot n_{\xi}) \times (d(n,q)+d(n,q-1) \cdot n_{\xi})}$, $Q(w(t)) \in \mathbb{R}^{(d(n,q-1) \cdot n_{\xi}) \times (d(n,q)+d(n,q-1) \cdot n_{\xi})}$, and $\Gamma(\gamma(w, \dot{w})) \in \mathcal{U}$ satisfying one of the following equivalent sets of conditions:

$$(i) \begin{cases} P(w(t)) > 0 \\ \mathcal{H}e(\mathcal{A}_{\{q\}}^T(w(t))(P(w(t))\mathcal{E} + \mathcal{E}_0 Q(w(t)))) + \\ \mathcal{E}^T P(\dot{w}(t))\mathcal{E} + B \text{diag}(\Gamma(\gamma(w, \dot{w})), 0_{d(n,q-1) \cdot n_{\xi}}) < 0 \end{cases} \quad (4.7)$$

$\forall w(t) \in \mathcal{W}$ and $\dot{w}(t) \in \mathcal{V}$;

$$(ii) \begin{cases} P(w(t)) > 0 \\ \left[\begin{array}{c|c} \mathcal{E}^T P(\dot{w}(t))\mathcal{E} + \\ \mathcal{H}e(F(w(t))\mathcal{A}_{\{q\}}(w(t))) + \\ B \text{diag}(\Gamma(\gamma(w, \dot{w})), 0_{d(n,q-1) \cdot n_{\xi}}) & * \\ \hline P(w(t))\mathcal{E} + \mathcal{E}_0 Q(w(t)) + \\ G(w(t))\mathcal{A}_{\{q\}}(w(t)) - F^T(w(t)) & -\mathcal{H}e(G(w(t))) \end{array} \right] < 0 \end{cases} \quad (4.8)$$

$\forall w(t) \in \mathcal{W}$ and $\dot{w}(t) \in \mathcal{V}$.

The matrix $\mathcal{E}_0 \in \mathbb{R}^{(d(n,q)+d(n,q-1)n_{\xi}) \times (d(n,q-1)n_{\xi})}$ is the orthogonal complement of \mathcal{E} . The Lyapunov function associated to the above sets of conditions is given by (4.5).

Proof. Necessity: Suppose that the system (4.1) is admissible with a PPD-HPLF of degree $2q$. By using Lemma 3.3.1, the associated extended system (3.9) is known to be admissible with a quadratic Lyapunov function of the form (4.5). For such candidate

to be a Lyapunov function, the positive-definiteness of the function is required, as well as the negative-definiteness of its time derivative. These requirements are fulfilled in the two sets of inequalities presented in (i).

Sufficiency: Suppose that inequalities (i) are satisfied. Then, a quadratic Lyapunov function for the extended system (3.9) exists, and it ensures both the admissibility of the extended system (3.9) via a quadratic Lyapunov function, and the admissibility of the original system (4.1) via a PPD-HPLF of degree $2q$.

Equivalence: (i) \rightarrow (ii): Consider the strict inequality (4.7). There exists a small scalar e such that left side of inequality (4.7) $< -\frac{e}{2}\mathcal{A}_{\{q\}}^T(w(t))\mathcal{A}_{\{q\}}(w(t))$. The choices $F = \mathcal{E}^T P(w(t)) + Q^T(w(t))\mathcal{E}_0^T$ and $G = e \cdot I_{d(n,q)+d(n,q-1)\cdot n_\xi}$ along with the use of Schur complements lead to inequality (4.8).

(ii) \rightarrow (i): A multiplication of the left side of inequality (4.8) by the matrices $\begin{bmatrix} I_{d(n,q)+d(n,q-1)\cdot n_\xi} & \mathcal{A}_{\{q\}}^T(w(t)) \end{bmatrix}$ and $\begin{bmatrix} I_{d(n,q)+d(n,q-1)\cdot n_\xi} & \mathcal{A}_{\{q\}}^T(w(t)) \end{bmatrix}^T$, to the right and to the left respectively, lead to inequality (4.7). □

Remark 4.3.5. *Some complementary degrees of freedom associated to the Lyapunov function given above can be highlighted. The first of them is related to the CMSR described in Definition 1.2.21, caused by the power transformation of the state vectors. The second of them is related to the rank-deficiency of the matrix \mathcal{E} , and it can be exploited by the orthogonal complement of this matrix. The orthogonal complement appears explicitly in [BSC13, Theorem 1] and is represented by E_0 . In our Theorem 3.3.3, it appears implicitly in the triangular structure of P , as detailed in the proof.*

Remark 4.3.6. *The negative-definiteness of the derivative of the Lyapunov function can accommodate the so-called slack variables that are referred as $F(w(t))$ and $G(w(t))$ in (4.8). When the infinite amount of conditions to be observed (i.e. inequality (4.8) must be verified for every possible values of parameters and parameter's rate of variation) is brought to a finite amount of conditions due to a certain choice on the structure of the unknown matrices, the slack variables might provide extra degrees of freedom, leading to less conservative results.*

The admissibility conditions presented in Lemma 4.3.4 might lead to nonlinear matrix inequalities. In the following, two different structures of the involved variables are chosen in order to obtain new LMI admissibility conditions for uncertain descriptor systems subject to parameters with bounded velocities.

Theorem 4.3.7 ([SPB18a]). *The polytopic uncertain descriptor system (4.1) subject to parameters with bounded rates of variation is robustly admissible based on a PPD-HPLF if there exist matrices $P^{(i)} > 0$, $Q^{(i)}$, F , G , and $\Gamma_{il}(\gamma) \in \mathcal{U}$ in (4.3), $i = 1 \dots N$, $l = 1 \dots h$, of the same dimensions as in Lemma 4.3.4, satisfying the LMI conditions below:*

$$\begin{bmatrix} \mathcal{E}^T P(d^l) \mathcal{E} + \mathcal{H}e(F \mathcal{A}_{\{q\}}^{(i)}) + B \text{diag}(\Gamma_{il}(\gamma), 0_{d(n,q-1)\cdot n_\xi}) & \star \\ P^{(i)} \mathcal{E} + \mathcal{E}_0 Q^{(i)} + G \mathcal{A}_{\{q\}}^{(i)} - F^T & -\mathcal{H}e(G) \end{bmatrix} < 0, \quad (4.9)$$

$i = 1, \dots, m, l = 1, \dots, h.$

Matrices $\mathcal{A}_{\{q\}}^{(i)}$ are the vertices of $\mathcal{A}_{\{q\}}$, that is the dynamic matrix of the extended descriptor system associated to (4.1), in accordance with the notation of (3.9).

Proof. Condition (4.9) is directly derived from (4.8) through the particular choice of constant slack variables $F(w(t)) = F$ and $G(w(t)) = G$, and by considering polytopic realizations of matrices $P(w(t))$ and $Q(w(t))$. We recall that the term $\Gamma(\gamma(w, \dot{w}))$ in (4.8) spans a linear space, and that the dependence of $\gamma(w, \dot{w})$ with respect to the parameters, and to the parameter's velocities, can be conveniently chosen in such a way that the term $\Gamma_{il}(\gamma)$ is convex with respect to these both independent sets. Therefore, the matrix inequality (4.9) still holds convexity and can be evaluated in the finite set $\mathcal{W} \times \mathcal{V}$. \square

Remark 4.3.8. Theorem 4.3.7 covers the results provided in [BSC13]. Indeed, the conditions in [BSC13] are given for the existence of a quadratic Lyapunov function, and do not consider extra degrees of freedom related to the CMSR (see Remark 4.3.5). This particular case is translated to the choice $q = 1$, and $\gamma(w, \dot{w}) \equiv 0$.

Theorem 4.3.9 ([SPB18a]). The polytopic uncertain descriptor system (4.1) subject to parameters with bounded rates of variation is robustly admissible based on a PPD-HPLF if there exist polytopic matrices $P(w(t))$, $F(w(t))$, $G(w(t))$, and $Q(w(t))$, of the same dimensions as in Lemma 4.3.4, given by

$$\begin{aligned} P(w(t)) &= \sum_{i=1}^N w_i(t) P^{(i)}, & Q(w(t)) &= \sum_{i=1}^N w_i(t) Q^{(i)}, \\ F(w(t)) &= \sum_{i=1}^N w_i(t) F_i, & G(w(t)) &= \sum_{i=1}^N w_i(t) G_i, \end{aligned}$$

for $w(t) \in \mathcal{W}$ and $\dot{w}_i(t) \in \mathcal{V}$, such that the LMI conditions (4.10) are satisfied. Matrices $\Gamma_{il}(\gamma)$, $i = 1, \dots, N$, $l = 1, \dots, h$; $\Lambda_{ijl}(\gamma)$, $i = 1, \dots, N$, $j = 1, \dots, N$, $j \neq i$, $l = 1, \dots, h$; and $\Omega_{ijkl}(\gamma)$, $i = 1, \dots, N-2$, $j = i+1, \dots, N-1$, $k = j+1, \dots, N$, $l = 1, \dots, h$, belong to the set \mathcal{U} .

Proof. Consider the polytopic definition of the system (4.1) and of matrices $P(w(t))$, $Q(w(t))$, $F(w(t))$, $G(w(t))$ and $P(\dot{w}(t))$, this last one being deployed in Remark 4.3.2. Using Lemma 4.3.4, system (4.1) is robustly admissible if (4.8) holds, whose left side is given as in (4.11).

Please note that $\Gamma_{il}(\gamma)$, $\Lambda_{ijl}(\gamma)$ and $\Omega_{ijkl}(\gamma)$ are dependent upon (w, \dot{w}) , two independent sets. We conveniently choose a structure for such matrices that is affine with both of these sets.

Whenever inequalities (4.10) hold, it follows that the left hand side of (4.8), expressed as in (4.11), satisfies inequality (4.12). Since the scalar

$$\sum_{l=1}^h \sigma_l \left(\sum_{i=1}^N w_i^3 - \frac{1}{(N-1)^2} \sum_{j=1; j \neq i}^N w_i^2 w_j - \frac{6}{(N-1)^2} \sum_{i=1}^{N-2} \sum_{j=i+1}^{N-1} \sum_{k=j+1}^N w_i w_j w_k \right)$$

$$\left[\begin{array}{c|c} \mathcal{E}^T P(d^l) \mathcal{E} + \mathcal{H}e(F_{i,\mathcal{A}_{\{q\}}^{(i)}}) + \text{Bdiag}(\Gamma_{il}(\gamma), 0_{d(n,q-1) \cdot n_{\xi}}) & \star \\ \hline P^{(i)} \mathcal{E} + \mathcal{E}_0 Q^{(i)} + G_{i,\mathcal{A}_{\{q\}}^{(i)}} - F_i^T & -\mathcal{H}e(G_i) \end{array} \right] < - \begin{bmatrix} I_{d(n,q)+d(n,q-1) \cdot n_{\xi}} & \\ & 0_{d(n,q)+d(n,q-1) \cdot n_{\xi}} \end{bmatrix},$$

$$i = 1, \dots, N, l = 1, \dots, h.$$

$$\left[\begin{array}{c|c} 3\mathcal{E}^T P(d^l) \mathcal{E} + \mathcal{H}e(F_{i,\mathcal{A}_{\{q\}}^{(j)}} + F_{j,\mathcal{A}_{\{q\}}^{(i)}} + F_{i,\mathcal{A}_{\{q\}}^{(i)}}) + \text{Bdiag}(\Lambda_{ijl}(\gamma), 0_{d(n,q-1) \cdot n_{\xi}}) & \star \\ \hline 2(P^{(i)} \mathcal{E} + \mathcal{E}_0 Q^{(i)} - F_i^T) + (P^{(j)} \mathcal{E} + \mathcal{E}_0 Q^{(j)} - F_j^T) + G_{i,\mathcal{A}_{\{q\}}^{(j)}} + G_{j,\mathcal{A}_{\{q\}}^{(i)}} + G_{i,\mathcal{A}_{\{q\}}^{(i)}} & -\mathcal{H}e(2G_i + G_j) \end{array} \right] < \frac{1}{(N-1)^2} \begin{bmatrix} I_{d(n,q)+d(n,q-1) \cdot n_{\xi}} & \\ & 0_{d(n,q)+d(n,q-1) \cdot n_{\xi}} \end{bmatrix},$$

$$i = 1, \dots, N, j = 1, \dots, N, j \neq i, l = 1, \dots, h.$$

$$\left[\begin{array}{c|c} 6\mathcal{E}^T P(d^l) \mathcal{E} + \mathcal{H}e(F_{i,\mathcal{A}_{\{q\}}^{(j)}} + F_{i,\mathcal{A}_{\{q\}}^{(k)}} + F_{j,\mathcal{A}_{\{q\}}^{(k)}} \\ + F_{j,\mathcal{A}_{\{q\}}^{(i)}} + F_{k,\mathcal{A}_{\{q\}}^{(i)}} + F_{k,\mathcal{A}_{\{q\}}^{(j)}}) + \text{Bdiag}(\Omega_{ijkl}(\gamma), 0_{d(n,q-1) \cdot n_{\xi}}) & \star \\ \hline 2(P^{(i)} + P^{(j)} + P^{(k)}) \mathcal{E} + 2\mathcal{E}_0(Q^{(i)} + Q^{(j)} + Q^{(k)}) - 2(F_i^T + F_j^T + F_k^T) \\ + G_{i,\mathcal{A}_{\{q\}}^{(j)}} + G_{j,\mathcal{A}_{\{q\}}^{(i)}} + G_{i,\mathcal{A}_{\{q\}}^{(k)}} + G_{k,\mathcal{A}_{\{q\}}^{(i)}} + G_{j,\mathcal{A}_{\{q\}}^{(k)}} + G_{k,\mathcal{A}_{\{q\}}^{(j)}} & -2\mathcal{H}e(G_i + G_j + G_k) \end{array} \right] < \frac{6}{(N-1)^2} \begin{bmatrix} I_{d(n,q)+d(n,q-1) \cdot n_{\xi}} & \\ & 0_{d(n,q)+d(n,q-1) \cdot n_{\xi}} \end{bmatrix},$$

$$i = 1, \dots, N-2, j = i+1, \dots, N-1, k = j+1, \dots, N, l = 1, \dots, h.$$

(4.10)

$$\begin{aligned}
\text{left-hand side of (4.8)} &= \sum_{l=1}^h \sigma_l \sum_{i=1}^N w_i^3 \left[\frac{\mathcal{E}^T P(d^l) \mathcal{E} + \mathcal{H}e(F_i \mathcal{A}_{\{q\}}^{(i)}) + B \text{diag}(\Gamma_{il}(\gamma), 0_{d(n,q-1) \cdot n_{\xi}})}{P^{(i)} \mathcal{E} + \mathcal{E}_0 Q^{(i)} + G_i \mathcal{A}_{\{q\}}^{(i)} - F_i^T} \middle| \begin{array}{c} \star \\ -\mathcal{H}e(G_i) \end{array} \right] + \\
&\sum_{l=1}^h \sigma_l \sum_{i=1}^N \sum_{j=1, j \neq i}^N w_i^2 w_j \left[\frac{3 \mathcal{E}^T P(d^l) \mathcal{E} + \mathcal{H}e(F_i \mathcal{A}_{\{q\}}^{(j)} + F_j \mathcal{A}_{\{q\}}^{(i)} + F_i \mathcal{A}_{\{q\}}^{(i)}) + B \text{diag}(\Lambda_{ijl}(\gamma), 0_{d(n,q-1) \cdot n_{\xi}})}{2(P^{(i)} \mathcal{E} + \mathcal{E}_0 Q^{(i)} - F_i^T) + (P^{(j)} \mathcal{E} + \mathcal{E}_0 Q^{(j)} - F_j^T) + G_i \mathcal{A}_{\{q\}}^{(j)} + G_j \mathcal{A}_{\{q\}}^{(i)} + G_i \mathcal{A}_{\{q\}}^{(i)}} \middle| \begin{array}{c} \star \\ -\mathcal{H}e(2G_i + G_j) \end{array} \right] + \\
&\sum_{l=1}^h \sigma_l \sum_{i=1}^{N-2} \sum_{j=i+1}^{N-1} \sum_{k=j+1}^N w_i w_j w_k \left[\frac{6 \mathcal{E}^T P(d^l) \mathcal{E} + \mathcal{H}e(F_i \mathcal{A}_{\{q\}}^{(j)} + F_i \mathcal{A}_{\{q\}}^{(k)} + F_j \mathcal{A}_{\{q\}}^{(k)} + F_j \mathcal{A}_{\{q\}}^{(i)} + F_k \mathcal{A}_{\{q\}}^{(i)} + F_k \mathcal{A}_{\{q\}}^{(j)}) + B \text{diag}(\Omega_{ijkl}(\gamma), 0_{d(n,q-1) \cdot n_{\xi}})}{2(P^{(i)} + P^{(j)} + P^{(k)}) \mathcal{E} + 2 \mathcal{E}_0 (Q^{(i)} + Q^{(j)} + Q^{(k)}) - 2(F_i^T + F_j^T + F_k^T) + G_i \mathcal{A}_{\{q\}}^{(j)} + G_j \mathcal{A}_{\{q\}}^{(i)} + G_i \mathcal{A}_{\{q\}}^{(k)} + G_k \mathcal{A}_{\{q\}}^{(i)} + G_j \mathcal{A}_{\{q\}}^{(k)} + G_k \mathcal{A}_{\{q\}}^{(j)}} \middle| \begin{array}{c} \star \\ -2\mathcal{H}e(G_i + G_j + G_k) \end{array} \right]
\end{aligned} \tag{4.11}$$

$$\left[\frac{\mathcal{E}^T \dot{P}(w(t)) \mathcal{E} + \mathcal{H}e(F(w(t)) \mathcal{A}_{\{q\}}(w(t))) + B \text{diag}(\Gamma(\gamma(w, \dot{w})), 0_{d(n,q-1) \cdot n_{\xi}})}{P(w(t)) \mathcal{E} + \mathcal{E}_0 Q(w(t)) + G(w(t)) \mathcal{A}_{\{q\}}(w(t)) - F^T(w(t))} \middle| \begin{array}{c} \star \\ -\mathcal{H}e(G(w(t))) \end{array} \right] < - \frac{6}{(N-1)^2} \sum_{i=1}^{N-2} \sum_{j=i+1}^{N-1} \sum_{k=j+1}^N w_i w_j w_k \left[\begin{array}{c} - \sum_{l=1}^h \sigma_l \left(\sum_{i=1}^N w_i^3 - \frac{1}{(N-1)^2} \sum_{j=1; j \neq i}^N w_i^2 w_j \right) \\ I_{d(n,q) + d(n,q-1) \cdot n_{\xi}} \\ 0_{d(n,q) + d(n,q-1) \cdot n_{\xi}} \end{array} \right] \tag{4.12}$$

can be rewritten as:

$$\begin{aligned} & \frac{1}{(N-1)^2} \sum_{l=1}^h \sigma_l \left((N-1)^2 \sum_{i=1}^N w_i^3 - \sum_{\substack{j=1; \\ j \neq i}}^N w_i^2 w_j - 6 \sum_{i=1}^{N-2} \sum_{j=i+1}^{N-1} \sum_{k=j+1}^N w_i w_j w_k \right) \\ & = \frac{1}{(N-1)^2} \sum_{l=1}^h \sigma_l \left((N-1)\Theta + \frac{\Omega}{2} \right), \end{aligned}$$

then it is positive semidefinite, given Θ as (1.76) and Ω as (1.77).

Furthermore, vector σ belongs to the unit simplex. Therefore, the left hand side of (4.8) is negative-definite *i.e.* (4.8) is satisfied, and the system (4.1) is admissible. \square

Remark 4.3.10. Theorem 4.3.9 also covers results proposed in the literature. When using a quadratic Lyapunov function and disconsidering the degrees of freedom associated to the CSMR, or in other words, when choosing $q = 1, \gamma \equiv 0$ for the stability analysis of a standard continuous-time uncertain system (e.g. $n_{\bar{z}} = 0, E = I_n$), the same conditions can be found in [LP03a].

The ensuing section brings numerical results that show reduction in the conservatism when using the proposed LMI conditions.

4.3.1 Numerical examples

In this section, numerical examples are proposed to show the performance of the LMI conditions of Theorem 4.3.7 and Theorem 4.3.9.

First, robust admissibility margins are obtained for uncertain descriptor systems subject to different bounds on parameters' velocities, and compared with results provided from techniques available in the literature. Then, the influence of the degree of PPD-HPLFs over the robust admissibility margins is evaluated.

Considering the system formulation given in (3.11), the polytopic systems we use for our numerical analysis are the following:

Example 1

$$E = B \text{diag}(I_3, 0),$$

$$A = \begin{bmatrix} -2r(t) & 1 & -r(t) & 0.5 \\ r(t) & -10r(t) & 1 + 3r(t) & 1 + r(t) \\ -1 + 3r(t) & -2 - 4r(t) & -4 + 2r(t) & 0 \\ 1 - r(t) & 0 & 0 & 1 + 0.2r(t) \end{bmatrix},$$

$$0 \leq r(t) \leq k, |\dot{r}(t)| \leq \beta,$$

that corresponds to system (3.11) with:

$$A^{(1)} = \begin{bmatrix} 0 & 1 & 0 & 0.5 \\ 0 & 0 & 1 & 1 \\ -1 & -2 & -4 & 0 \\ 1 & 0 & 0 & 1 \end{bmatrix}, \quad A^{(2)} = \begin{bmatrix} -2k & 0 & -k & 0 \\ k & -10k & 1+3k & 1+k \\ -1+3k & -2-4k & -4+2k & 0 \\ 1-k & 0 & 0 & 1+0.2k \end{bmatrix},$$

$$\{g^1, g^2\} = \left\{ \begin{bmatrix} -\gamma/k \\ \gamma/k \end{bmatrix}, \begin{bmatrix} \gamma/k \\ -\gamma/k \end{bmatrix} \right\}.$$

Example 2

$$E = Bdiag(I_2, 0),$$

$$A = \begin{bmatrix} -5+2r(t) & -2+r(t) & 0.1r(t) \\ 2 & -r(t) & 0 \\ 0 & 10r(t) & 1+0.1r(t) \end{bmatrix},$$

$$0 \leq r(t) \leq k, \quad |\dot{r}(t)| \leq \beta,$$

that corresponds to system (3.11) with:

$$A^{(1)} = \begin{bmatrix} -5 & -2 & 0 \\ 2 & -1 & 0 \\ 0 & 0 & 1 \end{bmatrix}, \quad A^{(2)} = \begin{bmatrix} -5+2k & -2+k & 0.1k \\ 2 & -k & 0 \\ 0 & 10k & 1+0.1k \end{bmatrix},$$

$$\{g^1, g^2\} = \left\{ \begin{bmatrix} -\gamma/k \\ \gamma/k \end{bmatrix}, \begin{bmatrix} \gamma/k \\ -\gamma/k \end{bmatrix} \right\}.$$

Example 3

$$E = Bdiag(I_2, 0),$$

$$A = \begin{bmatrix} 0 & 1 & 0.2 \\ -6-r(t) & -1 & 0 \\ 0.1 & 0.2 & 1+0.1r(t) \end{bmatrix},$$

$$-k \leq r(t) \leq k, \quad |\dot{r}(t)| \leq \beta,$$

that corresponds to system (3.11) with:

$$A^{(1)} = \begin{bmatrix} 0 & 1 & 0.2 \\ -6+k & -1 & 0 \\ 0.1 & 0.2 & 1-0.1k \end{bmatrix}, \quad A^{(2)} = \begin{bmatrix} 0 & 1 & 0.2 \\ -6-k & -1 & 0 \\ 0.1 & 0.2 & 1+0.1k \end{bmatrix},$$

$$\{g^1, g^2\} = \left\{ \begin{bmatrix} -\gamma/2k \\ \gamma/2k \end{bmatrix}, \begin{bmatrix} \gamma/2k \\ -\gamma/2k \end{bmatrix} \right\}.$$

We base the definition of robust admissibility margins on the previously given Definition 3.3.4 :

Definition 4.3.11 ($\kappa_{2q}^*(\beta)$): The ℓ_∞ $2q$ -PPD-HPLF admissibility margin with respect to the perturbation set $\kappa_{2q}^*(\beta)$ for a maximum velocity of parameters β is defined as:

$$\begin{aligned} \kappa_{2q}^*(\beta) &= \sup\{\kappa : \exists V_{2q} \text{ for (4.1), } r(t) \in \bar{\mathcal{B}}_\kappa, \\ &\quad |\dot{r}_i(t)| \leq \beta, i = 1, \dots, N\}, \\ \bar{\mathcal{B}}_\kappa &= \{b \in \mathbb{R}^m : 0 \leq b_i \leq \kappa, i = 1, \dots, N\}. \end{aligned}$$

For the proposed systems, $r(t)$ is a scalar, leading to $N = 2$.

Evaluation of robust admissibility margins and comparison with results from the literature

In this part, we compute the robust admissibility margins for the considered systems using conditions given in Theorem 4.3.7 and Theorem 4.3.9, and the ones found in Theorem 3.3.3, [Bar11b, Theorem 3.1], and [BSC13, Lemma 3]. The technique in Theorem 3.3.3 uses Lyapunov functions that are independent on the parameters, providing robust admissibility margins that are valid for an arbitrary parameters' rate of variation. However, the other techniques employ a Lyapunov function that is linearly dependent on parameters. We recall that the technique provided in [BSC13, Lemma 3] is covered by Theorem 4.3.7 for the choice $q = 1$ and for a realization $\gamma \equiv 0$. In other words, [BSC13, Lemma 3] provides an admissibility analysis based on the existence of a Lyapunov function that is quadratic on the state vector and that does not contain the extra degrees of freedom derived from the power transformation over the states.

From the results of the tables 4.1, 4.2 and 4.3, we remark that the results obtained by using the proposed LMI conditions in both Theorem 4.3.7 and Theorem 4.3.9 can lead to robust admissibility margins at least as big as the techniques proposed in the literature. This is particularly true because, first of all, the result proposed in [BSC13, Lemma 3] is covered in Theorem 4.3.7. Secondly, the condition proposed in [Bar11b, Theorem 3.1] has significant similarities to its counterpart in [BSC13, Lemma 3], but it presents less degrees of freedom than this latter one.

Throughout the tables we notice that, for a fixed degree of Lyapunov function, sometimes conditions Theorem 4.3.7 give better results than Theorem 4.3.9, but not always. Indeed, these conditions, as the ones previously presented in the literature, are sufficient, but not necessary, and they might not span the same space of solutions. Another phenomenon that can be observed in the tables is that a reduction of the conservatism might be obtained through an augmentation of the degree of the Lyapunov function, given by increasing q . However, this is not a rule, as shown in Table 4.2, column $\beta = 0$, and Table 4.3, columns $\beta = 0$ and $\beta = 5$. In these cases, robust admissibility margins become more restrictive with the the augmentation on the degree of the PPD-HPLFs. This point is discussed in the next section.

TABLE 4.1: $\kappa_{2q+}^*(100)$
for Example 1

		$\kappa_{2q}^*(100)$
Theorem 3.3.3	q=1	4.6667
	q=2	16.3940
	q=3	16.7008
[Bar11b, Theorem 3.1]		4.9337
[BSC13, Lemma 3]		4.9621
Theorem 4.3.7	q=1	4.9621
	q=2	16.6823
	q=3	16.7008
Theorem 4.3.9	q=1	4.9706
	q=2	16.6946
	q=3	16.7007

TABLE 4.2: $\kappa_{2q+}^*(50)$
for Example 2

		$\kappa_{2q}^*(50)$
Theorem 3.3.3	q=1	2.433
	q=2	2.899
	q=3	3.107
	q=4	3.132
	q=5	3.179
	q=6	3.195
	q=7	3.206
[Bar11b, Theorem 3.1]		2.4434
[BSC13, Lemma 3]		2.4434
Theorem 4.3.7	q=1	2.4434
	q=2	2.9097
	q=3	3.1074
	q=4	3.1449
	q=5	3.1855
	q=6	3.2022
	q=7	3.213
Theorem 4.3.9	q=1	2.4471
	q=2	2.9182
	q=3	3.1101
	q=4	3.1496
	q=5	3.1853
	q=6	3.2033
	q=7	3.2064

Evaluation of the augmentation of the degree of PPD-HPLFs

In this section, we compute for **Example 3** the maximum allowed velocity of parameters for a given dilation on the parameter set. We use conditions obtained from PPD-HPLFs of different orders within Theorem 4.3.7.

Interestingly, we notice from Figure 4.1 that the curves of different orders of PPD-HPLFs might overlap. For instance, among the performed tests, the PPD-HPLF providing the biggest allowed velocity of parameters for the dilation $\kappa_{2q|\cdot}^* = 4$ is the one of order 14, whilst for the dilation $\kappa_{2q|\cdot}^* = 5$, the best choice of order for a PPD-HPLF is 6. As a matter of fact, these results follow the same tendency displayed in the work [Che+07] for the standard uncertain systems case ($E = I_n$). Indeed, in [Che+07], it is highlighted that, for Lyapunov functions with parameter dependence of any degree higher than or equal to one, a mere augmentation on the degree of the state variables does not necessarily lead to better robust stability margins. That once more highlights one open problem concerning parameter-dependent homogeneous polynomial Lyapunov functions: there is no defined rule for choosing its best suitable order for a given system and given parameters' trajectories. It also shows that different PPD-HPLFs might provide different sets of necessary conditions, so that PPD-HPLFs of higher orders do not necessarily span the same space of solutions of PPD-HPLFs of

FIGURE 4.1: **Example 3:** Maximum allowed velocities of parameters for imposed admissibility margins $\kappa_{2q|\cdot}^*$ under conditions of Theorem 4.3.7 for PPD-HPLFs of different orders

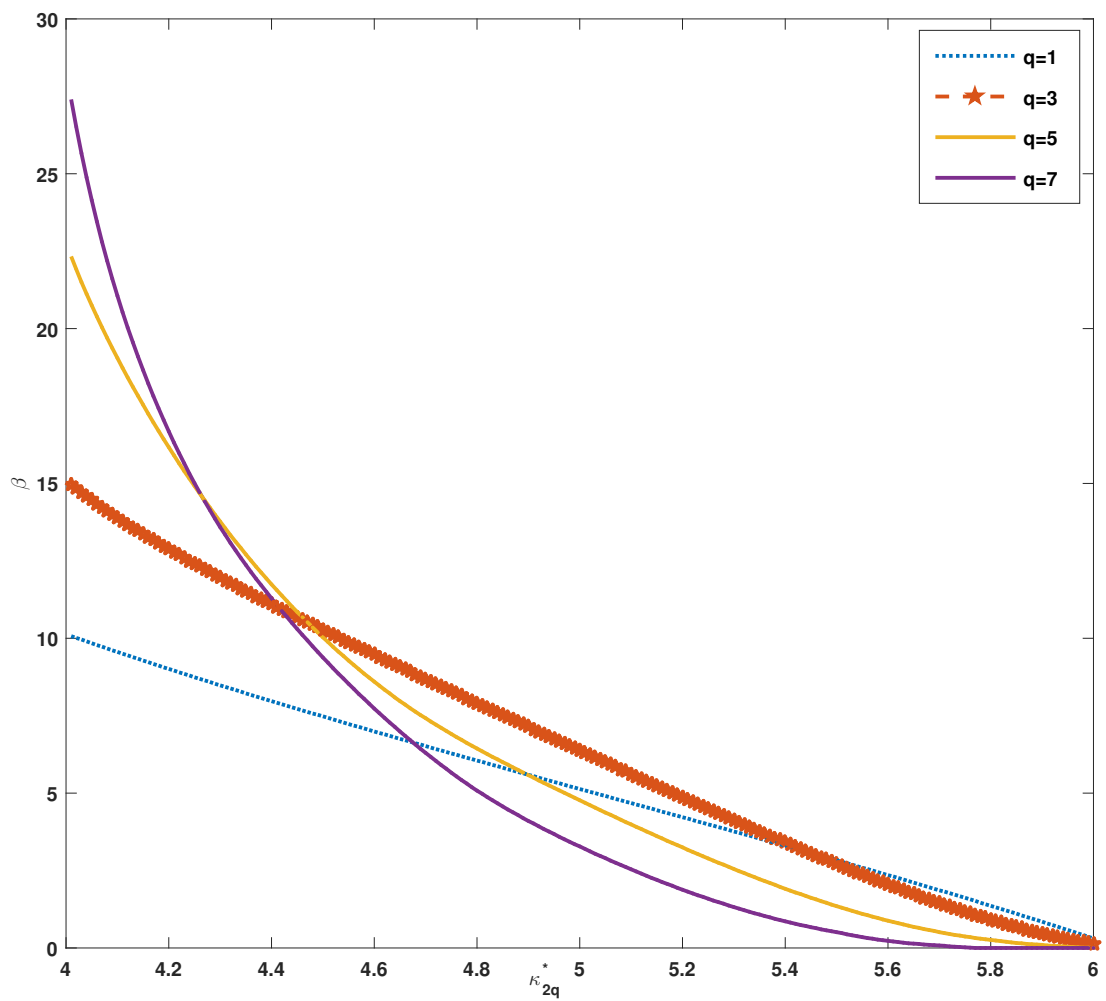

TABLE 4.3: $\kappa_{2q}^*(\beta)$ for Example 3

		$\kappa_{2q}^*(5)$	$\kappa_{2q}^*(100)$
Theorem 3.3.3	q=1	2.572	
	q=2	3.451	
	q=3	3.650	
	q=4	3.715	
	q=5	3.817	
	q=6	3.820	
	q=7	3.866	
[Bar11b, Theorem 3.1]		5.0139	2.5896
[BSC13, Lemma 3]		5.0304	2.5897
Theorem 4.3.7	q=1	5.0304	2.5897
	q=2	5.2756	3.4525
	q=3	5.1832	3.6588
	q=4	5.0798	3.7318
	q=5	4.9715	3.8236
	q=6	4.8779	3.8482
	q=7	4.8083	3.8728
Theorem 4.3.9	q=1	5.3228	2.5898
	q=2	5.2797	3.4531
	q=3	5.2423	3.6659
	q=4	5.1124	3.733
	q=5	4.986	3.826
	q=6	4.89	3.8401
	q=7	4.8131	3.8669

lower orders. As a matter of fact, the authors of [Che+07] state that, for standard uncertain systems, the joint augmentation on the degree of the homogeneous polynomial Lyapunov function with respect to the state and the parameter vectors might lead to less restrictive conditions. However, there is no guarantee that conservatism will decrease for an augmentation on the degree of the power transformation of the state vector alone.

4.4 Admissibility analysis based on homogeneously parameter-dependent HPLFs

In this section, we propose admissibility analysis conditions for uncertain descriptor systems through the existence of homogeneously parameter-dependent homogeneous polytopic Lyapunov functions (HPD-HPLFs).

Consider Lemma 3.3.1 that shows the equivalence between the admissibility of an uncertain descriptor system by means of a HPLF and the admissibility of its correspondent extended system by means of a quadratic Lyapunov function. In the previous chapter and section, we evaluated HPLFs in the form of (4.5) in which the Lyapunov matrix $P(w(t))$ is parameter-independent and linearly dependent on parameters, respectively. In the current section, we employ Lyapunov functions of the form

(4.5) containing homogeneous polynomial dependence in the vector of parameters. Indeed, one of the ways to represent the HPD-HPLF (1.68) is through the form (4.5), in which every entry of the Lyapunov matrix $P(w(t))$ is a homogeneous polynomial of degree s of the parameter vector.

It was shown in Theorem 3.3.3 that it is, actually, not restrictive to consider (4.5) in the following form:

$$V_{2q,s}(x(t), w(t)) = \begin{bmatrix} x^{[q]}(t) \\ x^{[q-1]}(t) \otimes \xi(t) \end{bmatrix}^T \mathcal{E}^T P(w(t)) \begin{bmatrix} x^{[q]}(t) \\ x^{[q-1]}(t) \otimes \xi(t) \end{bmatrix} \quad (4.13)$$

$$= x^{[q]}(t)^T P_{11}(w(t)) x^{[q]}(t), \quad (4.14)$$

with the choice of matrix $P(w(t)) = \begin{bmatrix} P_{11}(w(t)) & \mathbf{0}^{d(n,q) \times d(n,q-1) \cdot n_\xi} \\ P_{21}(w(t)) & P_{22}(w(t)) \end{bmatrix}$, each entry of $P(w(t))$ being homogeneous in w of degree s . As a matter of fact, $P(w(t))$ in (4.13) is equivalent to $P(w(t))\mathcal{E}$ in (4.5). Furthermore, in (4.13), the degrees of freedom related to the rank-deficiency of matrix \mathcal{E} are embedded in submatrices $P_{21}(w(t))$ and $P_{22}(w(t))$, as discussed in Remark 4.3.5. We recall that \mathcal{E} is the derivative matrix of the extended descriptor system associated to (4.1).

With a Lyapunov function candidate of form (4.13), we derive conditions for its eligibility to ascertain the admissibility of the uncertain descriptor system (4.1), imposing the positive-definiteness of (4.13) and the negative-definiteness of its time derivative. Each of these conditions will be developed in the following.

Positive-definiteness of the HPD-HPLF

Using Theorem 1.2.17 on the function $V_{2q,s}(x(t), w(t))$, we obtain that

$$\begin{aligned} V_{2q,s}(x(t), w(t)) &> 0 \quad \forall x(t) \in \mathbb{R}^n \setminus \{0_n\}, w \in \mathcal{W} \\ &\iff \\ V_{2q,2s}(x(t), sq(w(t))) &> 0 \quad \forall x(t) \in \mathbb{R}^n \setminus \{0_n\}, w \in \mathbb{R}^N \setminus \{0_N\}. \end{aligned} \quad (4.15)$$

We are interested in establishing the positive-definiteness of the function $V_{2q,s}(x(t), w(t))$, and this will be done through the form $V_{2q,2s}(x(t), sq(w(t)))$. In this latter form, every entry of the matrix $P(sq(w(t)))$ is a polynomial of degree $2s$ in the vector w . Thus, it is possible to write the (i, j) entry of $P(sq(w(t)))$ as

$$p_{ij}(sq(w)) = w^{[s]T} \Pi_{ij} w^{[s]}, \quad i = 1, \dots, d(n, q), \quad j = 1, \dots, d(n, q).$$

Matrices Π_{ij} belong to

$$\mathcal{O}(m, s) = \{\Pi_{ij} = \Pi_{ij}^T \in \mathbb{R}^{d(N,s) \times d(N,s)} : p_{ij}(sq(w)) \text{ does not contain monomials in } w \text{ with any odd power}\}.$$

The dimension of this linear space is [Che+07]

$$d_{\mathcal{O}}(N, s) = \frac{1}{2}d(N, s)(d(N, s) + 1) - (d(N, 2s) - d(N, s)).$$

With the definition of matrices Π_{ij} , we are able to rewrite $V_{2q, 2s}(x(t), sq(w(t)))$ as:

$$\begin{aligned} V_{2q, 2s}(x(t), sq(w(t))) &= x^{[q]}(t)^T P_{11}(sq(w(t))) x^{[q]}(t) \\ &= x^{[q]}(t)^T \underbrace{\begin{bmatrix} w^{[s]T} & & & \\ & w^{[s]T} & & \\ & & \ddots & \\ & & & w^{[s]T} \end{bmatrix}}_{(I \otimes w^{[s]})^T} \cdot \underbrace{\begin{bmatrix} \Pi_{11} & \Pi_{12} & \cdots & \Pi_{1d(n,q)} \\ \star & \Pi_{22} & \ddots & \vdots \\ & \cdots & & \\ \star & \star & \cdots & \Pi_{d(n,q)d(n,q)} \end{bmatrix}}_{H_1} \cdot \underbrace{\begin{bmatrix} w^{[s]} & & & \\ & w^{[s]} & & \\ & & \ddots & \\ & & & w^{[s]} \end{bmatrix}}_{(I \otimes w^{[s]})} x^{[q]}(t), \end{aligned} \quad (4.16)$$

where $(I \otimes w^{[s]}) \in \mathbf{R}^{d(n,q) \cdot d(N,s) \times d(n,q)}$ and $H_1 \in \mathbf{R}^{d(n,q) \cdot d(N,s) \times d(n,q) \cdot d(N,s)}$.

Note, however, that though matrix H_1 in (4.16) has size $d(n, q) \cdot d(N, s) \times d(n, q) \cdot d(N, s)$, it does not mean that it has $(d(n, q) \cdot d(N, s))^2$ free variables. Actually, $V_{2q, 2s}(x(t), sq(w(t)))$ has only $d(n, 2q) \cdot d(N, s)$ different monomials, and that is the amount of free variables contained in H_1 . Let α be the vector that contains these free variables, so that we write $H_1 = H_1(\alpha)$. This also allows us to write $P_{11}(w(t)) = P_{11}(w(t), \alpha)$.

Using properties of Kronecker products [Bre78], we obtain:

$$\begin{aligned} V_{2q, 2s}(x, sq(w), \alpha) &= x^{[q]T} \cdot (I \otimes w^{[s]})^T \cdot H_1(\alpha) \cdot (I \otimes w^{[s]}) \cdot x^{[q]} \\ &= (x^{[q]} \otimes w^{[s]})^T \cdot H_1(\alpha) \cdot (x^{[q]} \otimes w^{[s]}). \end{aligned} \quad (4.17)$$

Now, consider the linear space \mathcal{L} :

$$\begin{aligned} \mathcal{L} &= \{L = L^T \in \mathbf{R}^{d(n,q) \cdot d(N,s) \times d(n,q) \cdot d(N,s)} \mid \\ &\quad (x^{[q]} \otimes w^{[s]})^T \cdot L \cdot (x^{[q]} \otimes w^{[s]}) = 0 \forall x \in \mathbf{R}^n, w \in \mathbf{R}^N \setminus \{0_N\}\}. \end{aligned} \quad (4.18)$$

The dimension of \mathcal{L} is

$$d_{\mathcal{L}}(n, q, N, s) = \frac{1}{2}d(N, s)d(n, q)(d(N, s)d(n, q) + 1) - d(N, 2s)d(n, 2q). \quad (4.19)$$

We are able to comprise extra degrees of freedom in the description of (4.17) as follows:

$$V_{2q, 2s}(x, sq(w), \alpha, \lambda) = (x^{[q]} \otimes w^{[s]})^T \cdot \{H_1(\alpha) + \sum_{i=1}^{d_{\mathcal{L}}(n,q,N,s)} \lambda_i L_i\} \cdot (x^{[q]} \otimes w^{[s]}). \quad (4.20)$$

With these considerations, we can analyse the second condition to be satisfied by the Lyapunov function candidate (4.13).

Negative-definiteness of the time-derivative of the HPD-HPLF

Consider the definition of extended descriptor system presented in Lemma 3.3.1. We obtain as time-derivative of the Lyapunov function candidate (4.13) the form below:

$$\begin{aligned} \frac{d}{dt}V_{2q,s}(x, w, \alpha) = & \begin{bmatrix} x^{[q]}(t) \\ x^{[q-1]}(t) \otimes \xi(t) \end{bmatrix}^T \left(\mathcal{A}_{\{q\}}(w)^T P(w, \alpha) \right. \\ & \left. + P(w, \alpha) \mathcal{A}_{\{q\}}(w) + \frac{d}{dt}P(w, \alpha) \right) \begin{bmatrix} x^{[q]}(t) \\ x^{[q-1]}(t) \otimes \xi(t) \end{bmatrix}. \end{aligned} \quad (4.21)$$

The sum of terms $\mathcal{A}_{\{q\}}(w)^T P(w, \alpha) + P(w, \alpha) \mathcal{A}_{\{q\}}(w)$ has degree $s + 1$ in w . Each entry of $\frac{d}{dt}P(w, \alpha)$ has degree $s - 1$ in w , and a multiplication by the scalar $(\sum_{k=1}^N w_k)^2$ on each of its entries renders it dependent on w with the same homogeneous degree as the other terms in (4.21). After this manipulation, the function $\frac{d}{dt}V_{2q,s}(x, w, \alpha)$ becomes a homogeneous polynomial function of degree $2q$ in the state vector $\begin{bmatrix} x^{[q]}(t) \\ x^{[q-1]}(t) \otimes \xi(t) \end{bmatrix}$ and of degree $s + 1$ in the parameter vector w . We express this fact by using the notation $(\frac{d}{dt}V_{2q,s}(x, w, \alpha))_{2q, s+1}$.

To ensure the negative-definiteness of form $(\frac{d}{dt}V_{2q,s}(x, w, \alpha))_{2q, s+1}$, we use Theorem 1.2.17 and rather impose conditions upon the function $(\frac{d}{dt}V_{2q,s}(x, w, \alpha))_{2q, 2s+2}$. This leads to:

$$\begin{aligned} \left(\frac{d}{dt}V_{2q,s}(x, w, \alpha) \right)_{2q, 2s+2} &= \frac{d}{dt}V_{2q,s}(x, w, \alpha) \Big|_{w=sq(w)} \\ &= \begin{bmatrix} x^{[q]}(t) \\ x^{[q-1]}(t) \otimes \xi(t) \end{bmatrix}^T \left(\mathcal{A}_{\{q\}}(sq(w))^T P(sq(w), \alpha) + P(sq(w), \alpha) \mathcal{A}_{\{q\}}(sq(w)) \right. \\ & \quad \left. + \frac{d}{dt}P(w, \alpha) \Big|_{w=sq(w)} \cdot \left(\sum_{k=1}^N w_k^2 \right)^2 \right) \begin{bmatrix} x^{[q]}(t) \\ x^{[q-1]}(t) \otimes \xi(t) \end{bmatrix}. \end{aligned} \quad (4.22)$$

Using the same considerations made for writing the function $V_{2q,2s}(x(t), sq(w(t)))$ in the form (4.16), we are able to find a matrix

$$H_2(\alpha) \in \mathbf{R}^{\{d(N,s+1) \cdot (d(n,q) + d(n,q-1) \cdot n_\xi)\} \times \{d(N,s+1) \cdot (d(n,q) + d(n,q-1) \cdot n_\xi)\}} \text{ such that}$$

$$\mathcal{A}_{\{q\}}^T(sq(w))P(sq(w), \alpha) + P(sq(w), \alpha) \mathcal{A}_{\{q\}}(sq(w)) = (I \otimes w^{[s+1]})^T \cdot H_2(\alpha) \cdot (I \otimes w^{[s+1]}). \quad (4.23)$$

Likewise, there exists a matrix

$$H_3(\dot{w}, \alpha) \in \mathbf{R}^{\{d(N,s+1) \cdot (d(n,q) + d(n,q-1) \cdot n_\xi)\} \times \{d(N,s+1) \cdot (d(n,q) + d(n,q-1) \cdot n_\xi)\}} \text{ such that}$$

$$\frac{d}{dt}P(w, \alpha) \Big|_{w=sq(w)} \cdot \left(\sum_{k=1}^N w_k^2 \right)^2 = (I \otimes w^{[s+1]})^T \cdot H_3(\dot{w}, \alpha) \cdot (I \otimes w^{[s+1]}). \quad (4.24)$$

Consider the linear space \mathcal{U} :

$$\mathcal{U} = \left\{ U = U^T \in \mathbb{R}^{\{d(N,s+1) \cdot (d(n,q)+d(n,q-1) \cdot n_\xi)\} \times \{d(N,s+1) \cdot (d(n,q)+d(n,q-1) \cdot n_\xi)\}} \mid \right. \\ \left. \left(\begin{bmatrix} x^{[q]} \\ x^{[q-1]} \otimes \xi \end{bmatrix} \otimes w^{[s+1]} \right)^T \cdot U \cdot \left(\begin{bmatrix} x^{[q]} \\ x^{[q-1]} \otimes \xi \end{bmatrix} \otimes w^{[s+1]} \right) = 0, \right. \\ \left. \forall x \in \mathbb{R}^n, w \in \mathbb{R}^N \setminus \{0_N\} \right\} \quad (4.25)$$

The dimension of \mathcal{U} is given by

$$d_{\mathcal{U}}(n, q, N, s, n_\xi) = \begin{cases} d_{\mathcal{L}}(n, q, N, s+1) + d(n, q)d(n, q-1)d(N, s+1)^2 n_\xi \\ - d(n, 2q-1)d(N, 2s+2)n_\xi \\ + \frac{1}{2}d(n, q-1)d(N, s+1)n_\xi (d(n, q-1)d(N, s+1)n_\xi + 1) \\ - d(n, 2q-2)d(N, 2s+2)d(n_\xi, 2), & \text{if } n_\xi \neq 0, \\ d_{\mathcal{L}}(n, q, N, s+1), & \text{if } n_\xi = 0. \end{cases} \quad (4.26)$$

Remark 4.4.1 (About the dimension of the space \mathcal{U} , $d_{\mathcal{U}}$). The scalar $d_{\mathcal{U}}(n, q, N, s, n_\xi)$ re-groups the amount of degrees of freedom related to the couplings $(x^{[q]} \otimes w^{[s+1]}, x^{[q]} \otimes w^{[s+1]})$, $(x^{[q]} \otimes w^{[s+1]}, x^{[q-1]} \otimes \xi \otimes w^{[s+1]})$ and $(x^{[q-1]} \otimes \xi \otimes w^{[s+1]}, x^{[q-1]} \otimes \xi \otimes w^{[s+1]})$. When $n_\xi = 0$, the state vector of the extended system (3.9) is given by $x^{[q]}$. Therefore, the above mentioned couplings only take place between the pair $(x^{[q]} \otimes w^{[s+1]}, x^{[q]} \otimes w^{[s+1]})$, and this explains the reduced formulation of scalar $d_{\mathcal{U}}(n, q, N, s, n_\xi)$ for this particular case.

With the above considerations, we are able to write (4.22) as

$$\left(\frac{d}{dt} V_{2q,s}(x, w, \alpha, \phi) \right)_{2q, 2s+2} = \left(\begin{bmatrix} x^{[q]} \\ x^{[q-1]} \otimes \xi \end{bmatrix} \otimes w^{[s+1]} \right)^T \cdot \\ \left(H_2(\alpha) + H_3(i\dot{v}, \alpha) + \sum_{i=1}^{d_{\mathcal{U}}(n,q,N,s,n_\xi)} \phi_i U_i \right) \cdot \left(\begin{bmatrix} x^{[q]} \\ x^{[q-1]} \otimes \xi \end{bmatrix} \otimes w^{[s+1]} \right). \quad (4.27)$$

Based on the previous considerations, we present in the following theorem novel admissibility criteria for uncertain descriptor system by means of HPD-HPLFs.

Theorem 4.4.2 ([SPB18b]). The uncertain descriptor system (4.1) subject to time-varying parameters with bounded rates of variation is robustly admissible with a HPD-HPLF if there exist free parameter vectors $\alpha \in \mathbb{R}^{d(n,2q) \cdot d(N,s)}$, $\lambda \in \mathbb{R}^{d_{\mathcal{L}}(n,q,N,s)}$ and $\phi \in \mathbb{R}^{hd_{\mathcal{U}}(n,q,N,s,n_\xi)}$, such that there are symmetric matrices $H_1(\alpha) \in \mathbb{R}^{d(n,q) \cdot d(N,s) \times d(n,q) \cdot d(N,s)}$, $H_2(\alpha)$ and $H_3(\alpha) \in \mathbb{R}^{\{d(N,s+1) \cdot (d(n,q)+d(n,q-1) \cdot n_\xi)\} \times \{d(N,s+1) \cdot (d(n,q)+d(n,q-1) \cdot n_\xi)\}}$ such that the following LMI conditions hold:

$$H_1(\alpha) + \sum_{i=1}^{d_{\mathcal{L}}(n,q,N,s)} \lambda_i L_i > 0; \quad (4.28)$$

$$H_2(\alpha) + H_3(\alpha, g^j) + \sum_{i=1}^{d_{\mathcal{U}}(n,q,N,s,n_\xi)} \phi_{ij} U_i < 0, \quad j = 1, \dots, h. \quad (4.29)$$

Proof. The first inequality (4.28) ensures the positive-definiteness of the sought Lyapunov function by enforcing the positive-definiteness over the form (4.20), and the second condition (4.29) guarantees the negative-definiteness of the time-derivative of the Lyapunov function by imposing negative-definiteness over the function (4.27). \square

Remark 4.4.3 (Correlation with [Che+07]). *The results of this section cover the ones found in [Che+07], where HPD-HPLFs are employed for standard uncertain systems. In [Che+07], the Lyapunov function candidate is given by (1.68) and represented as:*

$$V_{2q,s}(x, w, \alpha) = (\text{sqr}(w)^{[s]} \otimes x^{[q]})^T \cdot H_{1c}(\alpha) \cdot (\text{sqr}(w)^{[s]} \otimes x^{[q]}). \quad (4.30)$$

where $H_{1c}(\alpha)$ is so that all the monomials in $V_{2q}(x, \text{sqr}(w))$ have integer degree in s .

Now we observe the Lyapunov function in (4.17) for the case $n_{\xi} = 0$. Likewise, it can be represented by:

$$V_{2q,s}(x, w, \alpha) = (x^{[q]} \otimes \text{sqr}(w)^{[s]})^T \cdot H_1(\alpha) \cdot (x^{[q]} \otimes \text{sqr}(w)^{[s]}). \quad (4.31)$$

By using properties of Kronecker products, we are able to determine the relationship between H_1 and H_{1c} . Indeed, based on permutation matrix properties [Bre78], (cf. Appendix A), the vectors $(x^{[q]} \otimes \text{sqr}(w)^{[s]})$ and $(\text{sqr}(w)^{[s]} \otimes x^{[q]})$ are related as:

$$x^{[q]} \otimes \text{sqr}(w)^{[s]} = U_{d(n,q) \times d(N,s)} (\text{sqr}(w)^{[s]} \otimes x^{[q]}). \quad (4.32)$$

Finally, replacing (4.32) in (4.31) and identifying the obtained expression, we find that

$$H_{1c} = U_{d(n,q) \times d(N,s)}^T H_1 U_{d(n,q) \times d(N,s)}.$$

4.4.1 Numerical examples

For the numerical examples, we use systems that were presented in the previous section for comparing our novel technique with other works found in the literature that also address the problem of robust admissibility of uncertain descriptor systems whose parameters have finite rate of variation. We first compare robust admissible margins for a fixed rate of variation, and then we verify the maximum allowed rate of variation for a given robustness margin. In our tests, we use **Example 2** and **Example 3** in section 4.3.1, and we consider the definition of $\kappa_{2q}^*(\beta)$ in Definition 4.3.11 for the computation of robust admissibility margins.

4.4.2 Evaluation of robust admissibility margins and comparison with results from the literature

In this part, we compute the robust admissibility margins $\kappa_{2q}^*(\beta)$ of the given systems. We compare the results provided by the technique proposed in Theorem 4.4.2 (arbitrary q and s) with Theorem 4.3.7, where a Lyapunov function homogeneous in the states and polytopic in the parameters is employed (arbitrary q and $s = 1$); and

Theorem 3.3.3, where a parameter-independent homogeneous polynomial Lyapunov function is used (arbitrary q and $s = 0$). We also display the results generated by conditions proposed in [Bar11b, Theorem 3.1], and [BSC13, Lemma 3] ($q = 1, s = 1$). We recall that the case $s = 0$ in Theorem 3.3.3 is specially pertinent to the study of uncertain descriptor systems with arbitrary rates of variation on the parameters.

The obtained robust admissibility margins $\kappa_{2q}^*(\beta)$ can be found in tables 4.4 and 4.5. In table 4.4, we notice that the HPLF framework is very powerful when compared to the quadratic approaches in [Bar11b, Theorem 3.1] and [BSC13, Lemma 3], because the augmentation of the degree q alone led to less conservative results than the ones given by the previous references.

It is known that, for standard systems, the augmentation on the state vector degree in a homogeneous polynomial Lyapunov function does not necessarily lead to less restrictive admissibility conditions. However, an augmentation on the degree of the parameter vector does not increase the degree of conservativeness [Che+07]. Furthermore, a suitable simultaneous augmentation of the degrees of state and parameter vectors might lead to less restrictive robustness margins. This has also been confirmed on descriptor systems through our numerical evaluation. These phenomena can be seen in both tables 4.4 and 4.5, where, for a given admissibility analysis technique, values on the same column do not necessarily grow from top to bottom, but values on the same line either remain constant or increase from left to right. We also note that the values of robust admissibility margins in the right bottom of each table are the greatest ones found there, highlighting the benefits of a joint augmentation of q and s .

TABLE 4.4: $\kappa_{2q}^*(50)$ for Example 2

		$\kappa_{2q}^*(50)$			
		$s = 0$	$s = 1$	$s = 2$	$s = 3$
[Bar11b, Theorem 3.1]			2.44		
[BSC13, Lemma 3]			2.44		
Theorem 3.3.3	q=1	2.43			
	q=2	2.89			
	q=3	3.10			
	q=4	3.13			
Theorem 4.3.7	q=1		2.44		
	q=2		2.90		
	q=3		3.10		
	q=4		3.14		
Theorem 4.4.2	q=1	2.47	2.48	2.48	2.62
	q=2	2.9	2.93	3.00	3.15
	q=3	2.88	2.91	3.02	3.12
	q=4	2.86	2.92	3.11	3.2

TABLE 4.5: $\kappa_{2q+}^*(5)$ for **Example 3**

		$\kappa_{2q}^*(5)$			
		$s = 0$	$s = 1$	$s = 2$	$s = 3$
[Bar11b, Theorem 3.1]			5.01		
[BSC13, Lemma 3]			5.03		
Theorem 3.3.3	q=1	2.57			
	q=2	3.45			
	q=3	3.65			
	q=4	3.71			
Theorem 4.3.7	q=1		5.03		
	q=2		5.27		
	q=3		5.18		
	q=4		5.07		
Theorem 4.4.2	q=1	2.33	5.38	5.67	5.73
	q=2	4.96	5.82	6.04	6.05
	q=3	4.45	5.66	6.03	6.05
	q=4	4.56	5.74	6.05	6.05

4.4.3 Evaluation of the maximum allowed parameters' rates of variation for different values of robust admissibility margins

In this section, **Example 3** was evaluated for increasing values of κ , and for each of these bounds the maximum velocity β that ensures admissibility was calculated according to Theorem 4.4.2. For that, Lyapunov functions of different degrees of dependence on the state and on the parameter vector were employed. Results are found in figures 4.2 and 4.3.

Once more, we note that an augmentation of q might make all the curves from a graph recede. That is what can be noticed between figures 4.2b and 4.2c, as well as in figure 4.3, where the criteria based on a Lyapunov function of degree 4 on the states ($q = 2$) lead to less restrictive margins in most part of the interval $[4.5, 6]$ of κ_{2q}^* . However, we note that curves with the same degree q and different degrees s (figures 4.2) do not cross each other, and that is due to the fact that an augmentation in s does not increase the conservativeness of a solution.

4.5 Conclusion

The present chapter presents robust admissibility analysis conditions for continuous-time polytopic uncertain descriptor systems with bounded rates of variation on parameters. We extend the scope of our previous work in Chapter 3 by proposing conditions that are based on parameter-dependent homogeneous polynomial Lyapunov functions.

In the first part, homogeneous polynomial Lyapunov functions with parameter dependence of degree 1 were used along with parameter-dependent slack variables to obtain necessary and sufficient conditions for the admissibility analysis of uncertain

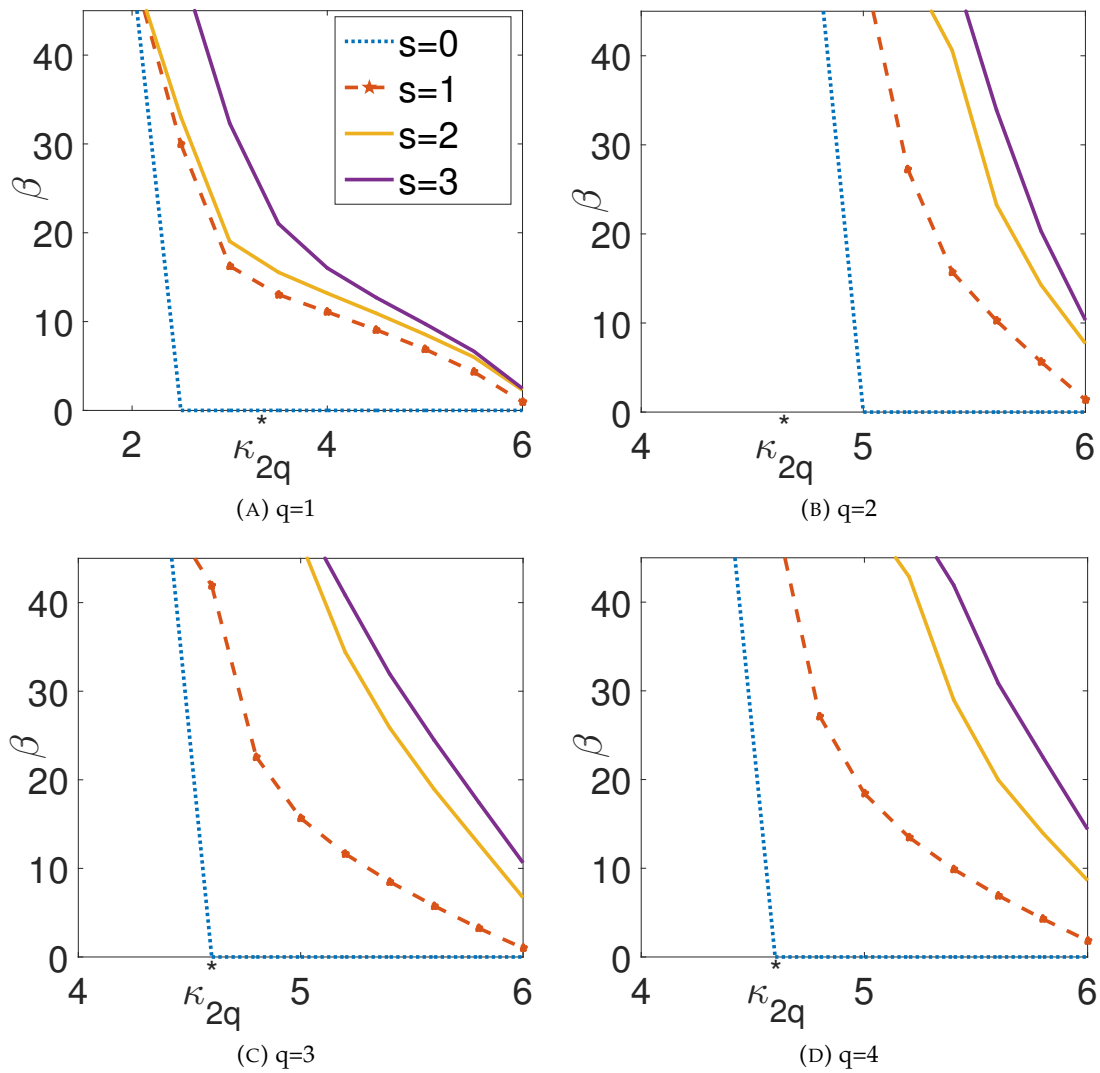
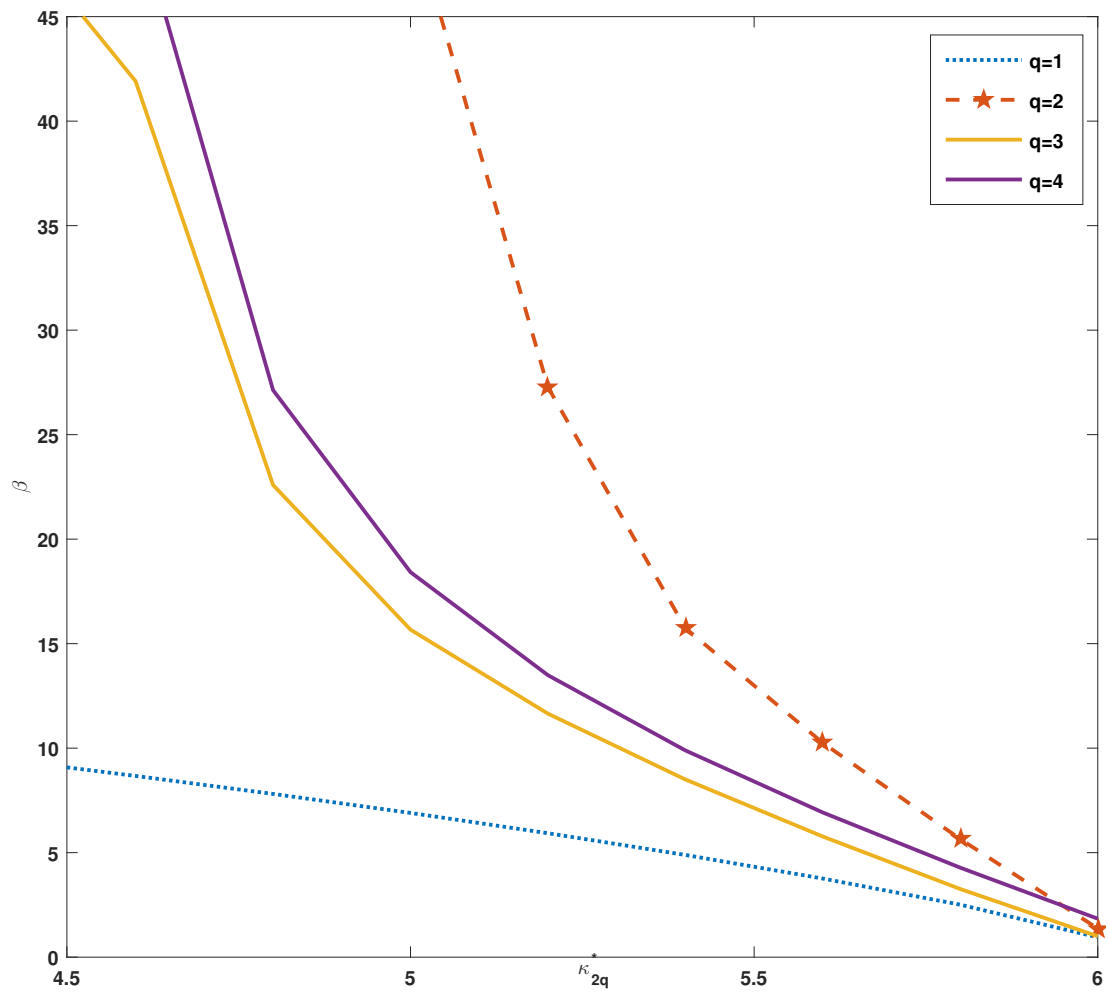

FIGURE 4.2: **Example 3:** Maximum allowed velocities of parameters β for increasing values of κ_{2q}^* and different degrees s on the parameter vector. Every figure is traced for a fixed degree q of state vector.

FIGURE 4.3: **Example 3:** Maximum allowed velocities β of parameters for increasing κ_{2q}^* for different degrees q of the state vector, and fixed degree $s = 2$ for the parameter vector.



descriptor systems. Then, through different convexification techniques, LMI conditions were obtained and compared by use on numerical examples. It is shown, in accordance with [Che+07], that for the case of parameter-dependent homogeneous polynomial Lyapunov functions, the augmentation of the polynomial degree can lead to less conservative results.

As a further study, homogeneous polynomial Lyapunov functions with arbitrary dependence on the parameter vector were employed to obtain LMI sufficient conditions for the admissibility analysis of uncertain descriptor system. It makes use of the degrees of freedom found in the complete square matricial representation to obtain less conservative solutions. Numerical results show a progressive improvement of the robust admissibility margins once both the degree of dependence on the state vector and on the parameter vector increase appropriately.

Chapter 5

Conclusions and perspectives

5.1 Summary of the thesis

This manuscript gathers research about the admissibility analysis of uncertain descriptor systems. This class of systems is placed among linear and nonlinear systems and enables the representation of impulses and algebraic constraints. Its versatility comes with a cost: the complexity of analysis and control is increased with respect to the classes of descriptor systems and uncertain systems alone. High complexity can be tackled by relaxations that often increase the conservativeness of solutions, and though a trade-off is set, research aims to provide less restrictive and reliable results with affordable computational power.

Therefore, there are still many open fields of research related to uncertain descriptor systems. Particularly about the robust admissibility analysis problem, on the one side, different convexification techniques have been proposed to reduce the dimensions of the set of conditions to be verified. On the other side, less restrictive conditions have been sought, mainly by means of Lyapunov functions. This thesis is mostly focused in the latter problem.

Lyapunov functions are a powerful mathematical tool for the analysis and control of dynamical systems. Its flexibility has provided less restrictive results through the selection of different dependences on the state and parameter vectors. The choice of a particular class of Lyapunov function can be determinant in the reduction of conservatism because some classes may not be universal for a given system of interest, meaning that not every class of Lyapunov function is able to assert the admissibility of an actual admissible system. In this thesis, we are interested in studying homogeneous polynomial Lyapunov functions because they are universal for uncertain systems. Among the universal Lyapunov functions for standard uncertain systems, the homogeneous polynomial type is particularly appealing because it can be represented in a quadratic structure through the so-called power transformation in the vector state. Nevertheless, homogeneous polynomial Lyapunov functions have never been used in the formulation of admissibility analysis conditions for uncertain descriptor systems because a definition of power transformation for such systems had not been set. The central interest of this project was to fill in this scientific gap.

This manuscript begins with a theoretical introduction to provide a basic understanding of the concepts that will be used throughout the document and give some insight of the open fields of research concerning the admissibility analysis of the larger class of uncertain descriptor systems. This theoretical introduction contains information about LTI descriptor systems and standard uncertain systems with the intention to facilitate the understanding of the properties of uncertain descriptor systems. Some findings in the literature concerning the admissibility analysis of descriptor systems, the stability analysis of standard uncertain systems, and the admissibility analysis of uncertain descriptor systems are evoked, and informations on homogeneous polynomial Lyapunov functions, that have been used for the robust stability analysis of standard uncertain systems, are given more in detail.

The second chapter contains our first contribution to the admissibility analysis of uncertain descriptor systems, and it is the only one related to the discrete-time case. There, we propose new necessary and sufficient admissibility analysis conditions for time-varying descriptor systems based on time-dependent Lyapunov functions and time-dependent slack variables. We also come up with a novel assumption that is required for the convergence of the time-varying descriptor system state vector towards the equilibrium. Then, we derive LMI sufficient conditions for the admissibility analysis of polytopic parameter-dependent uncertain descriptor systems containing parameter-dependent slack variables.

The third chapter brings our main contributions, that consists in generalizing the homogeneous polytopic Lyapunov function approach proposed for standard uncertain systems to uncertain descriptor systems. At first, we deal with standard uncertain systems, proposing a characterization of the linear mapping between an original system and its extended version. This novel characterization enables us to introduce new numerically tractable admissibility conditions using parameter-independent homogeneous polynomial Lyapunov functions and leads us to retrieve the power transformation of an uncertain descriptor system state vector for the first time.

The promising results obtained with parameter-independent Lyapunov functions propelled the research of admissibility conditions derived from parameter-dependent homogeneous polynomial Lyapunov functions for the same class of systems. In the fourth chapter, we investigate Lyapunov functions with parameter-dependence of order greater or equal to one, exploring different convexification techniques to obtain numerically tractable admissibility conditions.

5.2 Perspectives

The results obtained so far are merely the beginning of various contributions that may take place in future. Among them, it was mentioned [Che+07] that there is no technique to define an upper bound on the degree of homogeneous polynomial Lyapunov functions in order to obtain necessary and sufficient robust stability conditions for a

time-varying parameter-dependent system. Furthermore, to the best of our knowledge, all the techniques using homogeneous polynomial Lyapunov functions for stability and admissibility analysis address the continuous-time case, but not the discrete-time one. For the techniques here proposed, there can be envisaged extensions to the evaluation of H_2 and H_∞ performances, stabilizability, different types of controllability and observability, and control synthesis. There might be interest in better understanding the relationship between the original and the extended systems, evaluating how their dynamics are correlated, and extensions to neighbor fields, such as switched systems and singular perturbed systems, can be considered. Numerical libraries for uncertain descriptor systems would probably facilitate the use and understanding of this class of systems, and finally, the research of less restrictive convexification techniques would be beneficial for our domain and countless others.

Appendix A

Mathematical tools

A.1 Positive-definiteness of a matrix

A symmetric matrix $M \in \mathbb{R}^{n \times n}$ is respectively positive-definite, positive semidefinite, negative-definite and negative semidefinite if for any vector $x \in \mathbb{R}^n$, $x \neq 0^{n \times 1}$, one obtains $x^T M x > 0$, $x^T M x \geq 0$, $x^T M x < 0$ and $x^T M x \leq 0$. Furthermore, the eigenvalues of M are respectively all positive, positive and/or zero, all negative, negative and/or zero.

A.2 The convex hull [BV01]

The convex hull of a set w , $\text{Co}\{w\}$, is a set containing all the convex combinations of elements in w , such that

$$\text{Co}\{w\} = \{k_1 w^{(1)} + k_2 w^{(2)} + \dots + k_N w^{(N)} \mid w^{(i)} \in w \forall i = 1, \dots, N, k_i \geq 0, \sum_{i=1}^N k_i = 1\}. \quad (\text{A.1})$$

The convex hull of w is the smallest convex set that contains all the elements in w . Considering w as a set of vectors of size m , $w^{(i)}$, $i = 1, \dots, N$ are not only realizations of this set, but also the vertices of its convex hull.

A.3 Kronecker product

The Kronecker product between two matrices $M \in \mathbb{R}^{a \times b}$ and $N \in \mathbb{R}^{c \times d}$ is given by

$$M \otimes N \in \mathbb{R}^{(ac) \times (bd)} = \begin{bmatrix} M_{11}N & M_{12}N & \dots & M_{1b}N \\ M_{21}N & M_{22}N & \dots & M_{2b}N \\ & & \ddots & \\ M_{a1}N & M_{a2}N & \dots & M_{ab}N \end{bmatrix}. \quad (\text{A.2})$$

Several properties of the Kronecker product can be found, for example, in the reference [Bre78].

A.4 Norms

The k-norm of a vector $w \in R^m$ is given as

$$\|w\|_k = \left(\sum_{i=1}^m w_i^k \right)^{\frac{1}{k}}. \quad (\text{A.3})$$

The infinity norm of w is equivalent to $\|w\|_\infty = \max(|w_1|, |w_2|, \dots, |w_m|)$.

A.5 Linear Matrix Inequalities (LMIs) [SW99]

A Linear Matrix Inequality is an inequality constraint in the form

$$F(z) = F_0 + z_1 F_1 + z_2 F_2 + \dots + z_n F_n < 0, \quad (\text{A.4})$$

where $F_i \in R^{a \times a}$, $i = 0, \dots, n$ are symmetric matrices and z_i , $i = 1, \dots, n$ are real scalars named as *decision variables*. LMIs are, thus, affine functions of the decision variables.

As a matter of fact, LMIs can be defined in a more general manner, so that the decision variables are no longer scalars, but matrices. Therefore, a LMI $F(Z) < 0$ is an affine function of the decision variable $Z \in R^{a \times a}$ whose result is a symmetric matrix.

We note that the affine dependence on the decision variables renders the inequality (A.4) convex with respect to these decision variables. Convexity is a desirable property to be found in a matrix inequality problem because convex functions have only one global minimum/maximum, and this is of great interest for the numerical optimization.

LMIs are massively used in stability analysis and control synthesis problems because they count on numerical techniques, such as interior point methods, that grant them an efficient resolution. Furthermore, numerical tools, such as the Matlab Robust Control Toolbox and the parser Yalmip, provide a user-friendly experience in coding and obtaining solutions for LMI problems.

A.6 Schur complement

The Schur complement is a powerful tool that can simplify the parameter dependence of a problem. Consider the following inequality:

$$F(z) = \begin{bmatrix} F_{11}(z) & F_{12}(z) \\ F_{21}(z) & F_{22}(z) \end{bmatrix} < 0. \quad (\text{A.5})$$

It is equivalent to the following two sets of inequalities:

$$\begin{cases} F_{11}(z) < 0 \\ F_{11}(z) - F_{12}(z)F_{22}^{-1}(z)F_{21}(z) < 0 \end{cases} \quad \begin{cases} F_{22}(z) < 0 \\ F_{22}(z) - F_{21}(z)F_{11}^{-1}(z)F_{12}(z) < 0 \end{cases}$$

A.7 Finsler's lemma - Variant of [BSC12]

Given matrices $M(\zeta) = M(\zeta)^T$, $N(\zeta)$ and vector $\sigma(\zeta)$, with ζ in a set \mathcal{D} and appropriate dimensions for the matrices and vector, then

$$\sigma^T(\zeta)M(\zeta)\sigma(\zeta) < 0 \quad \forall \zeta \in \mathcal{D} \quad (\text{A.6})$$

in which $N(\zeta)\sigma(\zeta) = 0$ for $\sigma(\zeta) \neq 0$ holds if there exists a matrix L such that

$$M(\zeta) + \mathcal{H}e(LN(\zeta)) < 0 \quad \forall \zeta \in \mathcal{D}. \quad (\text{A.7})$$

A.8 Permutation matrix [Bre78]

A permutation matrix $U_{a \times b}$ is a square, full-rank matrix of size $ab \times ab$, given by:

$$U_{a \times b} = \sum_i^a \sum_k^b \begin{pmatrix} e_i \cdot e_k^T \\ (a) \quad (b) \end{pmatrix} \otimes \begin{pmatrix} e_k \cdot e_i^T \\ (b) \quad (a) \end{pmatrix}, \quad (\text{A.8})$$

where e_i is an $a \times 1$ vector having one in the i -th entry and zero elsewhere.

A.9 Toolboxes

Several toolboxes explore the subject of uncertain systems and descriptor systems. Here we collect some of them:

- *MATLAB Robust Control Toolbox* [Mat]: this toolbox provides mathematical tools for analysis and control of single-input-single-output (SISO) systems, as well as of multiple-input-multiple-output (MIMO) systems subject to uncertainties. Furthermore, it provides general purpose LMI-related resources with different functions and solvers.
- *R-RoMulOC - Randomized and Robust Multi-Objective Control toolbox* [Rro]: this toolbox provides tools for the resolution of the robust control problem for uncertain systems and LMI optimization problems for robust multi-objective control. The addressed system models can be given with different uncertainty structures, such as affine polytopic and linear fractional transformation (LFT). The analysis tools are based on Lyapunov theory and different criteria for robustness evaluations can be assessed. This toolbox uses the parser Yalmip for operating with different solvers.

- *SLICOT* [Sli]: this library proposes Fortran and Matlab based tools for addressing problems related to time-invariant multivariable systems analysis and synthesis. Such systems can be either descriptor or standard. Among the functionalities of the toolbox, one can find similarity transformations for descriptor and standard systems, solutions of Lyapunov and Riccati equations and model order reduction.
- *Descriptor System Tools (DSTOOLS)* [Var17]: this is a MATLAB-based library for the operation and manipulation of linear time-invariant systems through their correspondent descriptor realizations. It uses functions from MATLAB Robust Control Toolbox and SLICOT.
- *Model Order Reduction Laboratory (MORLAB) toolbox* [Mor; BW18]: this is a MATLAB-based toolbox that works with the model order reduction of LTI continuous-time systems and is able to address medium-scale descriptor systems.

Other than toolboxes, some important tools are used in the resolution of descriptor and uncertain systems related problems. Among them, the *solvers* provide the solutions of different optimization problems. In this thesis we are mostly interested in LMI feasibility problems that are solved through semidefinite programming, and for so, solvers LMILAB [Lmia; Lmib], MoseK [Mos] and SEDUMI [Sed] were employed. Although not addressed in this thesis, the control synthesis problem can lead to bilinear matrix inequality (BMI) problems that can be solved using the solver PENBMI [Pen]. Another important set of tools is the *parsers*, that are employed for interfacing optimization problems with different solvers, and are useful to the context of this thesis because the evoked LMI feasibility problems are solved through semidefinite programming. In this matter, the MATLAB Robust Control Toolbox and Yalmip toolbox [Lof04] provide a user-friendly platform for coding optimization problems.

Bibliography

- [AAA12] R. Ambrosino, M. Ariola, and F. Amato. "A Convex Condition for Robust Stability Analysis via Polyhedral Lyapunov Functions". In: *SIAM Journal on Control and Optimization* 50.1 (2012), pp. 490–506.
- [Alm+01] H. L. S. Almeida et al. "A team algorithm for robust stability analysis and control design of uncertain time-varying linear systems using piecewise quadratic Lyapunov functions". In: *International Journal of Robust and Nonlinear Control* 11.4 (Mar. 2001), pp. 357–371.
- [Alt06] C. Altafini. "Homogeneous Polynomial Forms for Simultaneous Stabilizability of Families of Linear Control Systems: a Tensor Product Approach". In: *Proceedings of the 45th IEEE Conference on Decision and Control, San Diego, USA* (Dec. 2006), pp. 1381–1386.
- [Ama06] Francesco Amato. *Robust Control of Linear Systems Subject to Uncertain Time-Varying Parameters*. Vol. 325. Lecture Notes in Control and Information Sciences. Springer-Verlag Berlin Heidelberg, 2006.
- [Aou12] Nedja Aouani. "Robust Control of LPV Systems". PhD thesis. Université du 7 Novembre à Carthage, June 2012.
- [Bar01] Gabriela Iuliana Bara. "Estimation d'état des systèmes linéaires à paramètres variants". PhD thesis. Institut National Polytechnique de Lorraine, 2001.
- [Bar11a] Gabriela Iuliana Bara. "Dilated LMI conditions for time-varying polytopic descriptor systems: the discrete-time case". In: *International Journal of Control* 84.6 (June 2011), pp. 1010–1023.
- [Bar11b] Gabriela Iuliana Bara. "Robust analysis and control of parameter-dependent uncertain descriptor systems". In: *Systems & Control Letters* 60.5 (Mar. 2011), pp. 356–364.
- [Bar94] B. Ross Barmish. *New Tools for robustness of linear systems*. Macmillan Publishing Company, 1994.
- [BL87] D.J. Bender and A. J. Laub. "The linear-quadratic optimal regulator for descriptor systems". In: *IEEE Transactions on Automatic Control* AC-32 (1987), pp. 672–688.
- [BM08] F. Blanchini and S. Miani. *Set-Theoretic Methods in Control*. Vol. Systems & Control: Foundations & Applications. Birkhäuser Basel, 2008.
- [BM95] Franco Blanchini and Stefano Miani. "Nonquadratic Lyapunov functions for robust control". In: *Automatica* 31.3 (1995), pp. 451–461.

- [BM99] Franco Blanchini and Stefano Miani. "A new class of universal Lyapunov functions for the control of uncertain linear systems". In: *IEEE Transactions on Automatic Control* 44.3 (1999), pp. 641–647.
- [BMS05] Peter Benner, Volker Mehrmann, and Sorensen C. Sorensen. *Dimension Reduction of Large-Scale Systems*. Vol. 45. Lecture Notes in Computational Science and Engineering. Springer-Verlag Berlin Heidelberg, 2005.
- [Boy+94] Stephen Boyd et al. *Linear Matrix Inequalities in System and Control Theory*. Vol. 15 of Studies in Applied Mathematics, Society for Industrial and Applied Mathematics (SIAM), 1994.
- [Bre78] John W. Brewer. "Kronecker products and matrix calculus in system theory". In: *IEEE Transactions on Circuits and Systems* 25.9 (Sept. 1978), pp. 772–781.
- [Bro73] R. W. Brockett. *Lie algebra and Lie groups in control theory*. Vol. 3. In D.Q. Mayne and R.W. Brockett, editors, *Geometric Methods in Systems Theory*, NATO Advanced Study Institutes Series (Series C — Mathematical and Physical Sciences), pp. 43-82. Springer Dordrecht, 1973.
- [BSC12] K. A. Barbosa, C. E. de Souza, and D. Coutinho. "Robust stability of discrete-time linear descriptor systems with time-varying uncertainties via parametric Lyapunov function". In: *Proceeding of the 51st IEEE Conference on Decision and Control, Maui, Hawaii, USA*. Dec. 2012, pp. 5134–5139.
- [BSC13] K. A. Barbosa, C. E. de Souza, and D. Coutinho. "Robust admissibility and H_∞ performance of time-varying descriptor systems". In: *Proceeding of the 10th IEEE International Conference on Control and Automation (ICCA), Hangzhou, China*. June 2013, pp. 1138–1143.
- [BSP16] Gabriela Iuliana Bara and Ana Carolina dos Santos Paulino. "Homogeneous polynomial Lyapunov functions for uncertain systems". In: (2016). Internal Report, 2016.
- [BV01] Stephen Boyd and Lieven Vandenberghe. *Convex Optimization*. Cambridge University Press, 2001.
- [BW18] Peter Benner and Steffen W.R. Werner. "Model Reduction of Descriptor Systems with the MORLAB Toolbox". In: *9th Vienna International Conference on Mathematical Modelling* 51.2 (2018), pp. 547–552.
- [BZ83] A. I. Barkin and A. L. Zelentsovsky. "Method of power transformations for analysis of stability of nonlinear control systems". In: *Systems & Control Letters* 3 (1983), pp. 303–310.
- [CD12] M. Chadli and M. Darouach. "Novel bounded real lemma for discrete-time descriptor systems: Application to H_∞ control design". In: *Automatica* 48 (Jan. 2012), pp. 449–453.

- [CH08] C. T. Chang and H. P. Huang. "Robust joint-model-based control for constrained robots". In: *Proceeding of the IEEE Workshop on Advanced Robotics and its Social Impacts, Taipei, Taiwan*. Aug. 2008, pp. 1–6.
- [Che+02] Graziano Chesi et al. "LMI-based construction of homogeneous Lyapunov functions for systems with structured uncertainties". In: *Proceedings of the 41st IEEE Conference on Decision and Control, Las Vegas, Nevada, USA*. Dec. 2002, pp. 281–286.
- [Che+03a] Graziano Chesi et al. "Homogeneous Lyapunov functions for systems with structured uncertainties". In: *Automatica* 39 (Jan. 2003), pp. 1027–1035.
- [Che+03b] Graziano Chesi et al. "Robust stability of polytopic systems via polynomially parameter-dependent Lyapunov functions". In: *Proceedings of the 42nd IEEE Conference on Decision and Control, Maui, Hawaii, USA*. Dec. 2003, pp. 574–580.
- [Che+07] Graziano Chesi et al. "Robust stability of time-varying polytopic systems via parameter-dependent homogeneous Lyapunov functions". In: *Automatica* 43.2 (2007), pp. 309–316.
- [Che11] Graziano Chesi. "LMI conditions for time-varying uncertain systems can be non-conservative". In: *Automatica* 47.3 (2011), pp. 621–624.
- [CKM11] Stephen L. Campbell, Peter Kunkel, and Volker Mehrmann. *Control and Optimization with Differential-Algebraic Constraints – Chapter 2: Regularization of Linear and Nonlinear Descriptor Systems*. Society for Industrial and Applied Mathematics, 2011.
- [Dai89] L. Dai. *Singular control systems*. Lecture Notes in Control and Information Sciences, Springer-Verlag, 1989.
- [DB01] Jamal Daafouz and Jacques Bernussou. "Parameter dependent Lyapunov functions for discrete time systems with time varying parametric uncertainties". In: *Systems & Control Letters* 43 (2001), pp. 355–359.
- [Dua10] Guang-Ren Duan. *Analysis and Design of Descriptor Linear Systems*. Springer-Verlag New York, 2010.
- [Fan02] C. H. Fang. "Stability robustness analysis of uncertain descriptor systems - An LMI approach". In: *Proceedings of the 41st IEEE Conference on Decision and Control, Las Vegas, Nevada, USA*. 2002, pp. 1459–1460.
- [GAC94] Pascal Gahinet, Pierre Apkarian, and Mahmoud Chilali. "Parameter-Dependent Lyapunov Functions for Real Parametric Uncertainty". In: *IEEE Transactions on Automatic Control* (Dec. 1994).
- [GAC96] Pascal Gahinet, Pierre Apkarian, and Mahmoud Chilali. "Affine parameter-dependent Lyapunov functions and real parametric uncertainty". In: *IEEE Transactions on Automatic Control* 41.3 (1996), pp. 436–442.

- [Gar03] Raimundo Garrone. "Accident wounds Brazil's space program". In: *ABC Science* (Aug. 2003). Accessed on September 13, 2018. URL: <https://tinyurl.com/ybvst38d>.
- [GC06] José C. Geromel and Patrizio Colaneri. "Robust stability of time varying polytopic systems". In: *Systems & Control Letters* 55.1 (2006), pp. 81–85.
- [GCS03] Lixin Gao, Wenhai Chen, and Youxian Sun. "On robust admissibility condition for descriptor systems with convex polytopic uncertainty". In: *Proceeding of the 2003 American Control Conference, Denver, Colorado, USA*. 2003, pp. 5083–5088.
- [Ger04] Markus Gerdin. "Computation of a Canonical Form for Linear Differential-Algebraic Equations". In: *Linköping University Electronic Press*. 2004, 1–11.
- [Has+08] M. Hashizume et al. "New real-time MR image-guided surgical robotic system for minimally invasive precision surgery". In: *International Journal of Computer Assisted Radiology and Surgery* 2.6 (Apr. 2008), pp. 317–325.
- [HL99] K. L.-. Hsiung and L. Lee. "Lyapunov inequality and bounded real lemma for discrete-time descriptor systems". In: *IET Control Theory and Applications* 146.4 (July 1999), pp. 327–331.
- [HLB14] Housseem Halalchi, Edouard Laroche, and Gabriela Iuliana Bara. "Flexible-Link Robot Control Using a Linear Parameter Varying Systems Methodology". In: *International Journal of Advanced Robotic Systems* 11.3 (2014), p. 46.
- [IT02] João Yoshiyuki Ishihara and Marco Henrique Terra. "On the Lyapunov theorem for singular systems". In: *IEEE Transactions on Automatic Control* 47.11 (2002), pp. 1926–1930.
- [IT03] João Yoshiyuki Ishihara and Marco Henrique Terra. "A new Lyapunov equation for discrete-time descriptor systems". In: *Proceeding of the 2003 American Control Conference, Denver, Colorado, USA*. June 2003, pp. 5078–5082.
- [JW01] Zachary William Jarvis-Wloszek. "Matrix Representations of Polynomials: Theory and Applications". MA thesis. University of California, Berkeley, May 2001.
- [KF03] Ching-Hu Kuo and Chun-Hsiung Fang. "An LMI approach to admissibilization of uncertain descriptor systems via static output feedback". In: *Proceeding of the 2003 American Control Conference, Denver, Colorado, USA*. 2003, pp. 5104–5109.
- [LA77] David G. Luenberger and Ami Arbel. "Singular Dynamic Leontief Systems". In: *Econometrica* 45.4 (1977), pp. 991–995.

- [LCF04] Li Lee, Jian-Liung Chen, and Chun-Hsiung Fang. "On LMI approach to admissibilization of discrete-time descriptor systems". In: *Proceedings of the 5th Asian Control Conference, Melbourne, Australia*. 2004, pp. 1001–1008.
- [Lew86] F. L. Lewis. "A Survey of Linear Singular Systems". In: *Circuits Systems Signal Process* 5.1 (Sept. 1986), pp. 3–36.
- [Lmia] LMILAB. <https://yalmip.github.io/solver/lmilab/>. Accessed on October 23, 2018.
- [Lmib] *Tools for Specifying and Solving LMIs*. <https://fr.mathworks.com/help/robust/ug/introduction.html>. Accessed on October 23, 2018.
- [Lof04] J. Lofberg. "YALMIP : a toolbox for modeling and optimization in MATLAB". In: *Proceedings of the 2004 IEEE International Conference on Robotics and Automation*. Sept. 2004, pp. 284–289.
- [LP03a] V. J. S. Leite and P. L. D. Peres. "An improved LMI condition for robust D-stability of uncertain polytopic systems". In: *Proceeding of the 2003 American Control Conference, Denver, Colorado, USA*. June 2003, pp. 833–838.
- [LP03b] V. J. S. Leite and P. L. D. Peres. "An improved LMI condition for robust D-stability of uncertain polytopic systems". In: *IEEE Transactions on Automatic Control* 48.3 (Mar. 2003), pp. 500–504.
- [Mas+97] Izumi Masubuchi et al. " H_∞ Control for Descriptor Systems: A Matrix Inequalities Approach". In: *Automatica* 33.4 (1997), pp. 669–673.
- [MAS03] I. Masubuchi, T. Akiyama, and M. Saeki. "Synthesis of output feedback gain-scheduling controllers based on descriptor LPV system representation". In: *Proceedings of the 42nd IEEE Conference on Decision and Control, Maui, Hawaii, USA*. Dec. 2003, pp. 6115–6120.
- [Mat] *MathWorks - Robust Control ToolboxTM*. <https://fr.mathworks.com/products/robust.html>. Accessed on October 23, 2018.
- [MG89] J. K. Mills and A. A. Goldenberg. "Force and position control of manipulators during constrained motion tasks". In: *IEEE Transactions on Robotics and Automation* 5.1 (Feb. 1989), pp. 30–46.
- [MKG03] B. Marx, D. Koenig, and D. Georges. "Robust pole-clustering for descriptor systems a strict LMI characterization". In: *Proceeding of the European Control Conference, Cambridge, United Kingdom*. Sept. 2003, pp. 1117–1122.
- [Mor] MORLAB - Model Order Reduction Laboratory. <http://www.mpi-magdeburg.mpg.de/projects/morlab>. Accessed on October 23, 2018.
- [Mos] *Mosek*. <https://www.mosek.com/>. Accessed on October 23, 2018.
- [MP03] V. F. Montagner and Pedro L.D. Peres. "A new LMI condition for the robust stability of linear time-varying systems". In: *Proceedings of the 42nd IEEE Conference on Decision and Control, Maui, Hawaii, USA*. Vol. 6. Dec. 2003, pp. 6133–6138.

- [OBG99] M.C. de Oliveira, J. Bernussou, and J.C. Geromel. "A new discrete-time robust stability condition". In: *Systems & Control Letters* 37 (1999), pp. 261–265.
- [OBP08] Ricardo C.L.F. Oliveira, P. Bliman, and Pedro L.D. Peres. "Robust LMIs with parameters in multi-simplex: Existence of solutions and applications". In: *Proceedings of the 47th IEEE Conference on Decision and Control, Cancun, Mexico*. Dec. 2008, pp. 2226–2231.
- [OP07] Ricardo C.L.F. Oliveira and Pedro L.D. Peres. "Parameter-Dependent LMIs in Robust Analysis: Characterization of Homogeneous Polynomially Parameter-Dependent Solutions Via LMI Relaxations". In: *IEEE Transactions on Automatic Control* 52.7 (July 2007), pp. 1334–1340.
- [OP08] Ricardo C.L.F. Oliveira and Pedro L.D. Peres. "Robust stability analysis and control design for time-varying discrete-time polytopic systems with bounded parameter variation". In: *Proceeding of the 2008 American Control Conference, Washington, USA*. June 2008, pp. 3094–3099.
- [OP09] Ricardo C.L.F. Oliveira and Pedro L.D. Peres. "Time-varying discrete-time linear systems with bounded rates of variation: Stability analysis and control design". In: *Automatica* 45.11 (2009), pp. 2620–2626.
- [Pea+00] D. Peaucelle et al. "A new robust \mathcal{D} -stability condition for real convex polytopic uncertainty". In: *Systems & Control Letters* 40 (2000), pp. 21–30.
- [Pen] *PENBMI*. <http://www.penopt.com/penbmi.html>. Accessed on October 23, 2018.
- [RP01] Domingos C.W. Ramos and Pedro L.D. Peres. "A less conservative LMI condition for the robust stability of discrete-time uncertain systems". In: *Systems & Control Letters* 43 (2001), pp. 371–378.
- [RP02] Domingos C.W. Ramos and Pedro L.D. Peres. "An LMI condition for the robust stability of uncertain continuous-time linear systems". In: *IEEE Transactions on Automatic Control* 47.4 (2002), pp. 675–678.
- [Rro] *R-RoMulOC - Randomized and Robust Multi-Objective Control toolbox*. <http://homepages.laas.fr/peaucell/software.php>. Accessed on October 23, 2018.
- [SBF08] Carlos E. de Souza, Karina A. Barbosa, and Minyue Fu. "Robust filtering for uncertain linear discrete-time descriptor systems". In: *Automatica* 44 (2008), pp. 792–798.
- [SBN06] C. E. de Souza, K. A. Barbosa, and A. T. Neto. "Robust H_∞ filtering for discrete-time linear systems with uncertain time-varying parameters". In: *IEEE Transactions on Signal Processing* 54.6 (June 2006), pp. 2110–2118.
- [Sed] *SeDuMi - Optimization over symmetric cones*. <http://sedumi.ie.lehigh.edu/>. Accessed on October 23, 2018.

- [SF05] R. Sakuwa and Y. Fujisaki. "Robust stability analysis of single-parameter dependent descriptor systems". In: *Proceedings of the 44th IEEE Conference on Decision and Control, and the European Control Conference, Seville, Spain*. 2005, pp. 2933–2938.
- [Sli] SLICOT - Subroutine Library in Systems and Control Theory. <http://slicot.org/>. Accessed on October 23, 2018.
- [SPB17a] Ana Carolina dos Santos Paulino and Gabriela Iuliana Bara. "Homogeneous polynomial Lyapunov functions for the admissibility analysis of uncertain descriptor systems". In: *Proceeding of the 56th IEEE Conference on Decision and Control, Melbourne, Australia*. Dec. 2017, pp. 3187–3193.
- [SPB17b] Ana Carolina dos Santos Paulino and Gabriela Iuliana Bara. "New LMI conditions for admissibility analysis of time-varying descriptor systems". In: *Proceeding of the 20th IFAC World Congress, Toulouse, France* 50.1 (2017), pp. 15477–15482.
- [SPB18a] Ana Carolina dos Santos Paulino and Gabriela Iuliana Bara. "Polytopic parameter-dependent homogeneous polynomial Lyapunov functions for the analysis of uncertain descriptor systems". In: (2018). Submitted.
- [SPB18b] Ana Carolina dos Santos Paulino and Gabriela Iuliana Bara. "Robust admissibility of time-varying polytopic systems via parameter-dependent homogeneous polynomial Lyapunov functions". In: (2018). Submitted.
- [SW99] Carsten Scherer and Siep Weiland. *Lecture Notes DISC Course on Linear Matrix Inequalities in Control*. Version 2.0. Accessed on October 22, 2018. Apr. 1999. URL: <https://tinyurl.com/ydbbbf3r>.
- [TS99] Alexandre Trofino and Carlos E. de Souza. "Bi-quadratic stability of uncertain linear systems". In: *Proceedings of the 38th IEEE Conference on Decision and Control, Phoenix, Arizona, USA*. Vol. 5. Dec. 1999, pp. 5016–5021.
- [UI99] Eiho Uezato and Masao Ikeda. "Strict LMI conditions for stability, robust stabilization, and H_∞ control of descriptor systems". In: *Proceedings of the 38th IEEE Conference on Decision and Control, Phoenix, Arizona, USA*. 1999, pp. 4092–4097.
- [Var17] Andreas Varga. *Descriptor System Tools (DSTOOLS) User's Guide*. 2017. arXiv: [1707.07140](https://arxiv.org/abs/1707.07140) [cs.SY].
- [VD79] P. Van Dooren. "The computation of Kronecker's canonical form of a singular pencil". In: *Linear Algebra and its Applications* 27 (1979), pp. 103–140.
- [XSF97] Lin Xie, Serge Shishkin, and Minyue Fu. "Piecewise Lyapunov functions for robust stability of linear time-varying systems". In: *Systems & Control Letters* 31.3 (1997), pp. 165–171.

- [YBC08] M. Yagoubi, A. Bouali, and P. Chevrel. "Multiobjective controller synthesis for parameter dependent descriptor systems via dilated LMI characterizations". In: *Proceedings of the 47th IEEE Conference on Decision and Control, Cancun, Mexico*. Dec. 2008, pp. 4801–4806.
- [Zel94] A. L. Zelentsovsky. "Nonquadratic Lyapunov functions for robust stability analysis of linear uncertain systems". In: *IEEE Transactions on Automatic Control* 39.1 (1994), pp. 135–138.
- [ZXS08] Gaomin Zhang, Yuanqing Xia, and Peng Shi. "New bounded real lemma for discrete-time singular systems". In: *Automatica* 44.3 (2008), pp. 886–890.

Robust analysis of uncertain descriptor systems using non quadratic Lyapunov functions

Résumé

Les systèmes descripteurs incertains sont convenables pour la représentation des incertitudes d'un modèle, du comportement impulsif et des contraintes algébriques entre les variables d'état. Ils peuvent décrire bien plus de phénomènes qu'un système dynamique standard, mais, en conséquence, l'analyse des systèmes descripteurs incertains est aussi plus complexe.

Des recherches sont menées de façon à réduire le degré de conservatisme dans l'analyse des systèmes descripteurs incertains. L'utilisation des fonctions de Lyapunov qui sont en mesure de générer des conditions nécessaires et suffisantes pour une telle évaluation y figurent. Les fonctions de Lyapunov polynomiales homogènes font partie de ces classes, mais elles n'ont jamais été employées pour les systèmes descripteurs incertains.

Dans cette thèse, nous comblons ce vide dans la littérature en étendant l'usage des fonctions de Lyapunov polynomiales homogènes du cas incertain standard vers les systèmes descripteurs incertains.

Mots-clés : systèmes descripteurs incertains, fonctions de Lyapunov non quadratiques, conditions nécessaires et suffisantes, inégalités matricielles linéaires.

Abstract

Uncertain descriptor systems are a convenient framework for simultaneously representing uncertainties in a model, as well as impulsive behavior and algebraic constraints. This is far beyond what can be depicted by standard dynamic systems, but it also means that the analysis of uncertain descriptor systems is more complex than the standard case.

Research has been conducted to reduce the degree of conservatism in the analysis of uncertain descriptor systems. This can be achieved by using classes of Lyapunov functions that are known to be able to provide necessary and sufficient conditions for this evaluation. Homogeneous polynomial Lyapunov functions constitute one of such classes, but they have never been employed in the context of uncertain descriptor systems.

In this thesis, we fill in this scientific gap, extending the use of homogeneous polynomial Lyapunov functions from the standard uncertain case for the uncertain descriptor one.

Keywords: uncertain descriptor systems, nonquadratic Lyapunov functions, necessary and sufficient conditions, LMIs.