



**HAL**  
open science

## 2-distance coloring of sparse graphs

Xuan Hoang La

► **To cite this version:**

Xuan Hoang La. 2-distance coloring of sparse graphs. Computer science. Université de Montpellier, 2022. English. NNT : 2022UMONS025 . tel-04041467

**HAL Id: tel-04041467**

**<https://theses.hal.science/tel-04041467v1>**

Submitted on 22 Mar 2023

**HAL** is a multi-disciplinary open access archive for the deposit and dissemination of scientific research documents, whether they are published or not. The documents may come from teaching and research institutions in France or abroad, or from public or private research centers.

L'archive ouverte pluridisciplinaire **HAL**, est destinée au dépôt et à la diffusion de documents scientifiques de niveau recherche, publiés ou non, émanant des établissements d'enseignement et de recherche français ou étrangers, des laboratoires publics ou privés.

# THÈSE POUR OBTENIR LE GRADE DE DOCTEUR DE L'UNIVERSITÉ DE MONTPELLIER

En Informatique

École doctorale : Information, Structures, Systèmes

Unité de recherche LIRMM, UMR 5506

## 2-distance coloring of sparse graphs

Présentée par **Hoang LA**  
Le 01 Juillet 2022

Sous la direction de Mickael Montassier,  
Alexandre Pinlou, et Petru Valicov

Devant le jury composé de

Marthe BONAMY, Chargé de recherche, Université de Bordeaux

Daniel CRANSTON, Associate professor, Virginia Commonwealth University

Louis ESPERET, Directeur de recherche, Université Grenoble Alpes

Fabien LAGUILLAUMIE, Professeur, Université de Montpellier

Mickael MONTASSIER, Professeur, Université de Montpellier

Alexandre PINLOU, Professeur, Université de Montpellier

Jean-Sébastien SERENI, Directeur de recherche, Université de Strasbourg

Petru VALICOV, Maître de conférences, Université de Montpellier

Examinatrice

Rapporteur

Rapporteur

Examineur, Président du jury

Directeur de thèse

Co-directeur de thèse

Examineur

Co-encadrant de thèse



UNIVERSITÉ  
DE MONTPELLIER

## Acknowledgements

---

D'abord, je voudrais remercier mes directeurs de thèse Mickaël, Alex, et Petru pour m'avoir guidé durant ces trois années de thèse. Votre soutien non seulement scientifique mais aussi moral m'a permis de bien mener ma thèse malgré la pandémie et pour cela je vous en suis très reconnaissant.

I would like to thank Dan and Louis for accepting to review my thesis. I am very grateful for your comments not only on the scientific content but also the writing style. I will take your advices to grow further as a researcher.

Je voudrais remercier Fabien pour présider mon jury et Jean-Sébastien pour être examinateur. Je remercie Marthe pour être examinatrice mais surtout pour ces conseils et son enthousiasme envers les thésards.

To all of my co-authors and collaborators, I would like to thank all of you for teaching me so many things during our time working together.

Je remercie l'équipe AIGCo et amis pour être très accueillant et ouvert face à mes questions et ma curiosité.

Je remercie les collègues à l'IUT de Montpellier-Sète pour m'avoir appris comment être un bon enseignant.

Con cảm ơn bố mẹ và gia đình vì đã đồng hành với con trong suốt quá trình con đi học. Anh cảm ơn Cu Tý for providing me with entertainments et pour ta curiosité envers mon travail.

Cuối cùng, con xin dành tặng luận văn tiến sĩ này cho ông nội. Con mong là con làm ông tự hào.

## Résumé

---

Dans cette thèse, on étudie le nombre chromatique à distance 2 des graphes épars, à savoir, les graphes planaires et les graphes avec degré moyen maximum borné. Les bornes supérieures sont obtenues en repoussant les limites de la méthode du déchargement. En particulier, on la combine avec la méthode du potentiel. De plus, on développe un outil d'assistance par ordinateur pour la procédure de déchargement. On fournit aussi des constructions pour les bornes inférieures sur le nombre chromatique à distance 2. Finalement, on étudie les variantes, à savoir, la coloration  $r$ -nuancée, la coloration injective et la coloration du carré exact.

## Abstract

---

In this thesis, we study the 2-distance chromatic number of sparse graphs, namely, planar graphs and graphs with bounded maximum average degree. Upper bounds are obtained by pushing the limits of the discharging method. In particular, we combine it with the potential method. Further, we develop a computer assistance framework for the discharging procedure. We also provide constructions for lower bounds of the 2-distance chromatic number. Finally, we study variants, namely  $r$ -hued coloring, injective coloring, and exact square coloring.

## Overview of the results in the thesis

---

In this thesis, we focus on the problem of 2-distance coloring of sparse graphs. Research on other subjects that was done during the thesis is also summarized in this overview. This manuscript does not present the proof of every result but the corresponding contribution can be found in the Appendix.

### 2-distance coloring of sparse graphs

In 1969, Kramer and Kramer introduced the notion of 2-distance coloring [80, 81]. This notion generalizes the “proper” constraint (that does not allow two adjacent vertices to have the same color) in the following way: a *2-distance  $k$ -coloring* is such that no pair of vertices at distance at most 2 have the same color. The *2-distance chromatic number* of  $G$ , denoted by  $\chi^2(G)$ , is the smallest integer  $k$  such that  $G$  has a 2-distance  $k$ -coloring. Similarly to proper  $k$ -list-coloring, one can also define *2-distance  $k$ -list-coloring*. We denote  $\chi_\ell^2(G)$  the *2-distance list chromatic number* of  $G$ .

For a graph  $G$ , we denote  $\Delta(G)$  the maximum degree of a graph  $G$ . One can observe that, for any graph  $G$ ,  $\Delta(G) + 1 \leq \chi^2(G) \leq \Delta^2(G) + 1$ . The lower bound is trivial since, in a 2-distance coloring, every neighbor of a vertex  $v$  with degree  $\Delta(G)$ , and  $v$  itself must have a different color. As for the upper bound, a greedy algorithm shows that  $\chi^2(G) \leq \Delta^2(G) + 1$ . Moreover, that upper bound is tight for some graphs like the cycle on five vertices or the Petersen graph.

By nature, (2-distance) list colorings and the (2-distance) list chromatic number of a graph depend a lot on the number of vertices in the neighborhood of every vertex. More precisely, the “sparser” a graph is, the lower its (2-distance) chromatic number will be. One way to quantify the sparsity of a graph is through its maximum average degree. The *maximum average degree*  $\text{mad}(G)$  is the maximum, over all subgraphs  $H$  of  $G$ , of  $\frac{2|E(H)|}{|V(H)|}$ . Another way to measure the sparsity is through the girth, i.e. the length of a shortest cycle. We denote  $g(G)$  the girth of  $G$ . Intuitively, the higher the girth of a graph is, the sparser it gets. These two measures are actually linked in the case of planar graphs (see Proposition 2).

A graph is *planar* if one can draw its vertices with points on the plane, and edges with curves intersecting only at its endpoints. When  $G$  is a planar graph, Wegner conjectured in 1977 that  $\chi^2(G)$  becomes linear in  $\Delta(G)$ :

**Conjecture 1** (Wegner [117]). Let  $G$  be a planar graph with maximum degree  $\Delta$ . Then,

$$\chi^2(G) \leq \begin{cases} 7, & \text{if } \Delta \leq 3, \\ \Delta + 5, & \text{if } 4 \leq \Delta \leq 7, \\ \lfloor \frac{3\Delta}{2} \rfloor + 1, & \text{if } \Delta \geq 8. \end{cases}$$

The upper bound for the case where  $\Delta \geq 8$  is tight. Recently, the case  $\Delta \leq 3$  was proved by Thomassen [114], and by Hartke *et al.* [66] independently. For  $\Delta \geq 8$ , Havet *et al.* [68] proved that the bound is  $\frac{3}{2}\Delta(1 + o(1))$ , where  $o(1)$  is as  $\Delta \rightarrow \infty$  (this bound holds for 2-distance list-colorings).

Wegner’s conjecture motivated extensive researches on 2-distance chromatic number of sparse graphs, planar graphs with high girth or graphs with upper bounded maximum average degree.

**Proposition 2** (Folklore). For every planar graph  $G$ ,  $(\text{mad}(G) - 2)(g(G) - 2) < 4$ .

As a consequence, any theorem with an upper bound on  $\text{mad}(G)$  can be translated to a theorem with a lower bound on  $g(G)$  under the condition that  $G$  is planar. Many results for  $\chi^2$  have the following form: “*every graph  $G$  of  $\text{mad}(G) \leq m_0$  and  $\Delta(G) \geq \Delta_0$  satisfies  $\chi^2(G) \leq \Delta(G) + c(m_0, \Delta_0)$  where  $c(m_0, \Delta_0)$  is a small constant depending only on  $m_0$  and  $\Delta_0$* ”. By Proposition 2, these results can be restated on planar graphs with girth  $g \geq g_0(m_0)$  where  $g_0$

$g_0 \backslash \chi^2(G)$	$\Delta + 1$	$\Delta + 2$	$\Delta + 3$	$\Delta + 4$	$\Delta + 5$	$\Delta + 6$	$\Delta + 7$	$\Delta + 8$
3				$\Delta = 3$				$\Delta = 4$
4							$\Delta = 4$	
5		$\Delta \geq 10^7$	$\Delta \geq 339$	$\Delta \geq 312$	$\Delta \geq 15$	$\Delta \geq 12$	$\Delta \neq 7, 8$	$\Delta \geq 3$
6		$\Delta \geq 17$	$\Delta \geq 9$		$\Delta \geq 3$			
7	$\Delta \geq 16$	$\Delta \geq 10$	$\Delta \geq 6$	$\Delta = 4$				
8	$\Delta \geq 9$	$\Delta \geq 6$	$\Delta \geq 3$					
9	$\Delta \geq 7$	$\Delta \geq 5$						
10	$\Delta \geq 6$	$\Delta \geq 4$						
11								
12	$\Delta \geq 5$	$\Delta \geq 3$						
13								
14	$\Delta \geq 4$							
...								
21	$\Delta \geq 3$							

Bảng 1: The latest results with a coefficient 1 before  $\Delta$  in the upper bound of  $\chi^2$ .

depends on  $m_0$ . In Table 1, we summarize the latest results on the 2-distance chromatic number of planar graphs with high girth.

For example, the result from line “7” and column “ $\Delta + 1$ ” reads: “*every planar graph  $G$  of girth at least 7 and of maximum degree  $\Delta$  at least 16 satisfies  $\chi^2(G) \leq \Delta + 1$* ”. The highlighted results are the contribution of this thesis, the corresponding statements are listed below.

[84] If  $G$  is a planar graph with  $g(G) \geq 21$ , then  $\chi^2(G) \leq \Delta(G) + 1$  for  $\Delta(G) \geq 3$ .

[85] If  $G$  is a graph with  $\text{mad}(G) < \frac{18}{7}$ , then  $\chi^2(G) \leq \Delta(G) + 1$  for  $\Delta(G) \geq 7$ .

[88] If  $G$  is a planar graph with  $g(G) \geq 8$ , then  $\chi^2(G) \leq \Delta(G) + 1$  for  $\Delta(G) \geq 9$ .

[87] If  $G$  is a planar graph with  $g(G) \geq 10$ , then  $\chi^2(G) \leq \Delta(G) + 2$  for  $\Delta(G) \geq 4$ .

[86] If  $G$  is a graph with  $\text{mad}(G) < \frac{8}{3}$ , then  $\chi^2(G) \leq \Delta(G) + 2$  for  $\Delta(G) \geq 6$ .

[86] If  $G$  is a graph with  $\text{mad}(G) < \frac{14}{5}$ , then  $\chi^2(G) \leq \Delta(G) + 2$  for  $\Delta(G) \geq 10$ .

[90] If  $G$  is a graph with  $g(G) \geq 8$ , then  $\chi^2(G) \leq \Delta(G) + 3$  for  $\Delta(G) \geq 3$ .

[82] If  $G$  is a graph with  $\text{mad}(G) < \frac{8}{3}$ , then  $\chi_\ell^2(G) \leq \Delta(G) + 3$  for  $\Delta(G) \geq 4$ .

[82] If  $G$  is a graph with  $\text{mad}(G) < \frac{14}{5}$ , then  $\chi_\ell^2(G) \leq \Delta(G) + 3$  for  $\Delta(G) \geq 6$ .

[89] If  $G$  is a planar graph with  $g(G) \geq 4$  and  $\Delta(G) = 4$ , then  $\chi_\ell^2(G) \leq \Delta(G) + 7$ .

The details of the proofs and the techniques involved in proving them is discussed in Chapter 2 and Chapter 3 of this manuscript.

In Chapter 4, we discuss the constructions of non 2-distance colorable graphs (for a given number of colors) when the girth is too small. More precisely, we contribute the following to the existing constructions.

[84] There exists a planar graph  $G$  with  $g(G) \geq 11$ ,  $\Delta(G) = 3$ , and  $\chi^2(G) \geq \Delta(G) + 2$ .

[87] There exists a planar graph  $G$  with  $g(G) \geq 4$  and  $\chi^2(G) \geq \Delta(G) + 3$ .

[87] There exists a planar graph  $G$  with  $g(G) \geq 5$ ,  $\Delta(G) = 4$ , and  $\chi^2(G) \geq \Delta(G) + 3$ .

[90] There exists a planar graph  $G$  with  $g(G) \geq 6$ ,  $\Delta(G) = 3$ , and  $\chi^2(G) \geq \Delta(G) + 3$ .

Finally, in Chapter 5, we present the following variants of 2-distance colorings:  $r$ -hued coloring, injective coloring, and exact square coloring.

### $r$ -hued coloring

The “2-distance” condition in 2-distance colorings requires that vertices at distance at most two have different colors. In other words, all neighbors of the same vertex must have different colors. This condition was generalized recently and the notion of  $r$ -hued coloring was introduced by Montgomery [98]. Let  $r, k \geq 1$  be two integers. An  $r$ -hued  $k$ -coloring of the vertices of  $G$  is a proper  $k$ -coloring of the vertices, such that all vertices are  $r$ -hued. A vertex is  $r$ -hued if the number of colors in its open neighborhood  $N_G(v) = \{x \mid xv \in E\}$  is at least  $\min\{d_G(v), r\}$ . The  $r$ -hued chromatic number of  $G$ , denoted  $\chi_r(G)$ , is the smallest integer  $k$  so that  $G$  has an  $r$ -hued  $k$ -coloring.

It is indeed a generalization of 2-distance colorings which corresponds to the case  $r \geq \Delta$ , as all vertices in the same neighborhood have different colors. More generally, its link to proper coloring and 2-distance coloring resides in the following equation:

$$\chi(G) = \chi_1(G) \leq \chi_2(G) \leq \dots \leq \chi_\Delta(G) = \chi_{\Delta+1}(G) = \dots = \chi^2(G) \quad (1)$$

Similar to the 2-distance chromatic number, the  $r$ -hued chromatic number is linear in  $r$  when it comes to planar graphs. In 2014, Song *et al.* proposed a generalization of Wegner’s conjecture:

**Conjecture 3** (Song *et al.* [108]). Let  $G$  be a planar graph. Then,

$$\chi_r(G) \leq \begin{cases} r + 3, & \text{if } 1 \leq r \leq 2, \\ r + 5, & \text{if } 3 \leq r \leq 7, \\ \lfloor \frac{3r}{2} \rfloor + 1, & \text{if } r \geq 8. \end{cases}$$

One can note that the case  $r = 1$  corresponds to the Four Color Theorem [3, 4]; additionally, by taking  $r = \Delta(G)$ , Conjecture 3 implies Wegner’s conjecture except for the case  $r = 3$ . Moreover, the only extremal known examples reaching the upper bounds of Conjecture 3 are the same as for Wegner’s conjecture.

The case of  $r = 2$  was proved by Chen *et al.* in [33]. Song and Lai [109] proved that, if  $r \geq 8$ , then every planar graph verifies  $\chi_r(G) \leq 2r + 16$ . Similar to 2-distance coloring, the coefficient before  $r$  in this upper bound becomes 1 for planar graphs with a higher girth (or graphs with lower mad).

Our contribution to the existing knowledge about  $r$ -hued coloring is the following.

**Theorem 4** ([88]). If  $G$  is a planar graph with  $g(G) \geq 8$ , then  $\chi_r(G) \leq r + 1$  for  $r \geq 9$ .

### Injective and exact square colorings

This work was done in collaboration with Kenny Štorgel.

An *injective coloring* of a graph  $G$  is a coloring of the vertices of  $G$  in which every pair of vertices with a common neighbor receive distinct colors. An *exact square coloring* of a graph  $G$  is a coloring of the vertices of  $G$  in which every pair of vertices at distance exactly two receive



distinct colors. This can also be extended to list-coloring. We denote  $\chi_\ell^i$ , the list injective chromatic number, and  $\chi_\ell^{\#2}$  the list exact square chromatic number.

Unlike the 2-distance coloring, both the injective coloring and the exact square coloring are not necessarily proper, i.e. adjacent vertices can receive the same color, provided that they satisfy certain conditions. For instance, in the exact square coloring two vertices can be colored with the same color if they are adjacent, and in the injective coloring two vertices can be colored with the same color if they are adjacent and do not share a common neighbor. It is therefore easy to observe that every 2-distance coloring is an injective coloring, and every injective coloring is an exact square coloring. Thus, for every graph  $G$  we have the following chain of inequalities:

$$\chi^{\#2}(G) \leq \chi^i(G) \leq \chi^2(G).$$

Moreover,  $\chi^{\#2}(G) = \chi^i(G)$  in the case of triangle-free graphs, i.e. graphs in which adjacent vertices cannot share a common neighbor.

The injective coloring was first introduced in 2002 by Hahn *et al.* [64]. The authors proved that for every graph  $G$ ,  $\Delta(G) \leq \chi^i(G) \leq \Delta^2(G) - \Delta(G) + 1$ . They also characterized the regular graphs which achieve the lower bound and the graphs which attain the upper bound. In 2005, Doyon *et al.* [49] presented the first results on injective colorings of planar graphs and later, Chen *et al.* [32] proved that for every  $K_4$ -minor free graph  $G$ ,  $\chi^i(G) \leq \lceil \frac{3}{2}\Delta(G) \rceil$  and in the same paper posed the following conjecture.

**Conjecture 5** (Chen *et al.* [32]). Let  $G$  be a planar graph with maximum degree  $\Delta$ . Then,

$$\chi^i(G) \leq \left\lceil \frac{3}{2}\Delta \right\rceil.$$

In 2015, the conjecture was disproved in general by Lužar and Škrekovski [95]. As a result, they proposed a new conjecture.

**Conjecture 6** (Lužar, Škrekovski [95]). Let  $G$  be a planar graph with maximum degree  $\Delta$ . Then,

$$\chi^i(G) \leq \begin{cases} 5, & \text{if } \Delta \leq 3, \\ \Delta + 5, & \text{if } 4 \leq \Delta \leq 7, \\ \left\lceil \frac{3}{2}\Delta \right\rceil + 1, & \text{if } \Delta \geq 8. \end{cases}$$

Note that since the injective coloring is a relaxation of the 2-distance coloring, proving Conjecture 1 would prove Conjecture 6, except in the case of subcubic graphs, i.e. the class of graphs with maximum degree 3. Brimkov *et al.* [21] proved that 5 colors suffice for subcubic planar graphs with girth at least 6. If true, then the conjectured upper bound for subcubic graphs is also tight (see, e.g., [95]).

Finally, the study of the exact distance  $p$ -powers of graphs was started by Simić [107] and exact  $p$ -distance colorings have first been studied in [101]. This parameter received an increasing attention in the last decade (see [20, 59, 70, 103]).

The following is our contribution to injective and exact square coloring.

**Theorem 7** ([89]). If  $G$  is a planar graph with  $\Delta(G) = 4$ , then  $\chi_\ell^i(G) \leq \Delta(G) + 7$ .

**Theorem 8** ([89]). If  $G$  is a planar graph with  $g(G) \geq 4$  and  $\Delta(G) = 4$ , then  $\chi_\ell^{\#2}(G) = \chi_\ell^i(G) \leq \Delta(G) + 5$ .

**Theorem 9** ([89]). If  $G$  is a planar graph with  $\Delta(G) = 4$ , then  $\chi_\ell^{\#2}(G) \leq \Delta(G) + 6$ .

## Research on other topics

---

During the three years of my Ph.D., I had the opportunities to collaborate with researchers from France, Slovenia, and Spain. During these collaborations, I worked on other research topics that are not related to 2-distance coloring.

### The 3-color Problem and precoloring extensions

This work was done in collaboration with Kenny Štorgel and Borut Lužar.

The Four Color Theorem provides an upper bound on the chromatic number of any planar graph, but determining which graphs achieve the equality is an NP-complete problem [43]. Consequently, searching for properties of (planar) graphs that guarantee 3-colorability is a very vibrant field (see, e.g., [13] for a survey). It turns out that triangles play an important role in this decision problem. Indeed, a cornerstone theorem of Grötzsch [62] states that every triangle-free planar graph is 3-colorable. Consequently, the focus turned to investigating ways in which triangles can appear in 3-colorable planar graphs. For example, for any planar triangulation, Heawood [69] showed that it is 3-colorable if and only if all of its vertices have even degrees.

Some triangles can be allowed in general planar graphs while maintaining 3-colorability: Havel [67] conjectured that a 3-colorable planar graph can contain arbitrarily many triangles as long as they are sufficiently far apart and Steinberg [111] conjectured that allowing triangles while forbidding cycles of length 4 and 5 is a sufficient condition for a planar graph to be 3-colorable. While Havel's conjecture has been proved by Dvořák *et al.* [50], Steinberg's conjecture has been refuted by Cohen-Addad *et al.* [35].

Another direction of research is focused on planar graphs with a small number of triangles. Grünbaum [63], Aksenov [1], then Borodin *et al.* [15] all provided proofs that a planar graph may contain three triangles and still retain 3-colorability.

The authors of [15] also presented short proofs of several other extensions of the Grötzsch Theorem, which guarantee 3-colorability of graphs being close to triangle-free planar graphs, improving upon multiple previous results.

We introduce new results about 3-colorability of planar graphs with small number of triangles and some precolored vertices, improving further on the results in [15].

**Theorem 10** ([83]). Let  $G$  be a planar graph with at most one triangle. Then each coloring of any two non-adjacent vertices can be extended to a 3-coloring of  $G$ .

The result is tight in terms of the number of precolored vertices and in terms of the number of triangles

**Theorem 11** ([83]). Let  $G$  be a planar graph with at most one triangle and let  $H$  be a graph such that  $G = H - v$  for some vertex  $v$  of degree at most 3 in  $H$ , which is adjacent with at most two vertices of the triangle in  $G$  if it exists. Then  $H$  is 3-colorable.

Again, the result is tight in terms of the number of precolored vertices and in terms of the number of triangles as well as in terms of the number of neighbors of  $v$  on the triangle.

**Theorem 12** ([83]). Let  $G$  be a planar graph with at most one triangle and let  $f$  be a face of  $G$  of length at most 4. Then each 3-coloring of  $f$  can be extended to a 3-coloring of  $G$ .

This result is tight in terms of the size of  $f$ .

Let  $K'_4$  be the graph obtained from  $K_4$  by subdividing once the three edges incident with a vertex  $v$ . We call a graph  $K'_4$ -free if it does not contain  $K'_4$  as a subgraph in such a way that the vertex  $v$  of  $K'_4$  has degree 3 also in  $G$ . It is easy to see that the vertices in the neighborhood of  $v$  cannot be colored with a same color.

**Theorem 13** ([83]). Let  $G$  be a  $K_4$ -free planar graph with at most one triangle. Then, for every vertex of degree at most 3 with an independent neighborhood, a precoloring of its neighbors with the same color can be extended to a 3-coloring of  $G$ .

This result is tight in terms of the degree of a vertex and in terms of the number of triangles.

Other than improving upon existing results, one motivation for the above-mentioned results was a conjecture on adynamic coloring of planar graphs with one triangle. An *adynamic coloring* is a proper vertex coloring of a graph  $G$  such that, for at least one vertex of degree at least 2 (denoted  $2^+$ -vertex), all of its neighbors are colored with a same color. Clearly, to admit such a coloring,  $G$  must have at least one  $2^+$ -vertex  $v$  with an independent neighborhood, i.e.  $v$  is not incident to a triangle.

In [116] by Šurimová et al., it was proved that every triangle-free planar graph admits an adynamic 3-coloring. On the other hand, there are planar graphs with two triangles that need 4 colors. Regarding planar graphs with one triangle, the authors of [116] conjectured that they are 3-colorable as soon as they contain a  $2^+$ -vertex with an independent neighborhood. Using the previous results, we answer the conjecture in affirmative.

**Theorem 14** ([83]). Every planar graph with at most one triangle and a  $2^+$ -vertex with an independent neighborhood is adynamically 3-colorable.

## Cops and Robber

This work was done in collaboration with Valentin Bartier, Laurine Bénéteau, Marthe Bonamy, and Jonathan Narboni.

*Cops and Robber* is a pursuit-evasion two-player turn-based game between the cops and the robber. In the first round, each cop chooses a starting vertex, then the robber chooses its starting vertex. Then, at each round, each cop chooses to move to an adjacent vertex, or to stay on its current vertex, then the robber has a similar choice. The cops win if after a finite number of rounds, a cop occupies the same vertex as the robber. The robber wins if he can indefinitely avoid the cops. The *cop number* of a graph  $G$ , which is denoted by  $c(G)$ , is the minimum number of cops needed to guarantee that they have a winning strategy. Albeit being very simple, this game is related to fundamental questions regarding the structural properties of graphs (see [10], [11] and [9] for a survey, and additional background on this game).

Here, we consider a new variant of this game, namely *Zombies and Survivor*, defined in [58] by Fitzpatrick *et al.* as follows: zombies take the place of the cops and the survivor takes the place of the robber. The zombies, being of limited intelligence, have a very simple objective in each round – to move closer to the survivor. Therefore, each zombie must move along some shortest path joining itself and the survivor. We say that the zombies capture the survivor if one of the zombies moves onto the same vertex as the survivor. In this version, zombies may have a choice as to which shortest path to follow, if there are multiple ones. Similarly to Cops and Robber, the *zombie number* of a graph  $G$  is the minimum number of zombies needed to ensure that the survivor will be eventually captured, and is denoted by  $z(G)$ .

Recall that a Cartesian product  $G \square H$  of graphs  $G = (V(G), E(G))$  and  $H = (V(H), E(H))$  is a graph such that the vertices is the Cartesian product  $V(G) \times V(H) = \{(u, v) | u \in V(G), v \in V(H)\}$  and the edges is the set  $\{((u, u'), (v, v')) | u = v \text{ and } (u', v') \in E(H), \text{ or } u' = v' \text{ and } (u, v) \in E(G)\}$ .

We proved the following theorems.

**Theorem 15** ([5]). For all graphs  $G$  and  $H$ ,  $z(G \square H) \leq z(G) + z(H)$ .

**Theorem 16** ([5]). Over all graphs  $G$ , the ratio  $\frac{z(G)}{c(G)}$  can be arbitrarily large.

These answers two questions asked as well as improved upon multiple results in [58].

## Feedback vertex sets in (directed) graphs of bounded degeneracy or treewidth

This work was done in collaboration with Petru Valicov and Kolja Knauer.

A set  $F \subseteq V(G)$  of vertices of a (directed) graph  $G$ , is a *feedback vertex set* if deleting  $F$  results in a (directed) graph without (directed) cycles. The complement of a feedback vertex set is called *acyclic set*. Deciding whether a graph has a feedback vertex set of a given size is NP-complete [73].

Because of its hardness, a natural class to study the minimum size of a feedback vertex set are sparse (directed) graphs. A particular example are planar graphs. The size of a minimum feedback vertex set in a planar graph is (famously) conjectured to be at most half the vertices by Albertson and Berman [2]. Up to date the best-known upper bound is  $\frac{3}{5}n$  achieved through acyclic colorings with Borodin's result [12]. This conjecture remains open even in the directed setting. Note that, in this setting, it is a weakening of the Neumann-Lara conjecture.

**Conjecture 17** (Neumann-Lara [100]). Every planar oriented graph can be vertex-partitioned into two acyclic sets.

Further, it is known that if true this bound is best-possible [78]. Moreover, it is noteworthy that the best known upper bound coincides with the above mentioned  $\frac{3}{5}n$  from the undirected setting [12].

Another class that has received attention in the directed setting are tournaments. Already Stearns [110] and Erdős and Moser [53] have shown that any tournament on  $n$  vertices admits a feedback vertex set of size  $n - \lfloor \log_2(n) \rfloor - 1$ , while there are tournaments where no feedback vertex set on less than  $n - 2\lfloor \log_2(n) \rfloor - 1$  vertices exists. More precise bounds for small values of  $n$  have been obtained by Sanchez-Flores [105, 106], Neiman *et al.* [99], and Lidický and Pfender [93].

We focus on the class of (directed) graphs of bounded treewidth or degeneracy. Here, the treewidth or degeneracy of a directed graph is simply the treewidth or degeneracy of its underlying undirected graph. Recall that every graph of treewidth  $k$  also has degeneracy  $k$ . In the undirected setting, the minimum feedback vertex set of graphs of bounded treewidth has been determined by Fertin *et al.* [57]: for a graph of order  $n$ , treewidth  $k$ , the size of a minimum feedback vertex set is at most  $\frac{k-1}{k+1}n$  and this bound is best-possible. Moreover, for odd degeneracy  $k$  it is easy to achieve the same upper bound. However, for even degeneracy the same argument only yields an upper bound of  $\frac{k}{k+2}n$ , and a lower bound of  $\frac{k-1}{k+1}n$ . Indeed, Borowiecki *et al.* [17] show that the true value for  $k = 2$  is  $\frac{2}{5}n$  which lies strictly between the above bounds.

Our main contribution here is to construct for any even  $k$  a family of graphs of degeneracy  $k$ , whose members of large order  $n$  have minimum feedback vertex sets whose size comes arbitrarily close to  $\frac{3k-2}{3k+4}n$ . Let  $n(G)$  be the number of vertices of  $G$  and  $f(G)$  be the size of a minimum feedback vertex set of  $G$ .

**Theorem 18** ([77]). For every even  $k$  there exists a family of  $k$ -degenerate graphs  $(G_i)_{i \in \mathbb{N}}$  such that  $n(G_i) = \frac{3k+6}{2} + i\frac{3k+4}{2}$  and  $f(G_i) = \frac{3k-2}{2} + i\frac{3k-2}{2}$ .

On the other hand we know that there exists no graphs of order  $n$  and even degeneracy  $k$  whose minimum feedback vertex set is of size  $\frac{k}{k+2}n$ .

**Proposition 19** ([77]). For every even  $k \geq 2$  there is a graph  $G$  with degeneracy  $k$ ,  $n(G) = \frac{(k+2)k}{2} + 1$  and  $f(G) = \frac{k^2}{2}$ .

In the directed setting, to our knowledge, apart from the above mentioned results in planar digraphs and tournaments, no classes of given degeneracy or treewidth have been studied previously. We give an upper bound for the smallest feedback vertex sets of  $n$ -vertex graphs of degeneracy  $k$ .

**Theorem 20** ([77]). Let  $D$  be a  $k$ -degenerate directed graph, we have  $f(D) \leq \frac{k-1}{k+1}n(D)$  and the inequality is strict when  $k$  is odd.

For  $k = 2$  and  $k = 3$ , this yields tight bounds  $\frac{1}{3}n$  and  $\frac{1}{2}n$ , respectively. For  $k = 2$ , the directed triangle is a simple example reaching the upper bound and for  $k = 3$ , the construction from [78] yields  $\frac{1}{2}n$  for degeneracy 3. Unlike the undirected setting, we know that there exists no graph of order  $n$  and odd degeneracy  $k$  whose minimum feedback vertex set is of size  $\frac{k-1}{k+1}n$ .

We also present constructions [77] for digraphs with large minimum feedback vertex set and given small degeneracy or treewidth that improve on the bounds obtained from using just tournaments from [105, 106, 99].

For general treewidth, by taking disjoint unions of the tournaments, one can find  $n$ -vertex digraphs of treewidth  $k$  and  $f \geq \frac{k-2\lfloor \log_2(k+1) \rfloor}{k+1}n$  [53]. However, we show that on general graphs of treewidth  $k$  one can force slightly larger minimum feedback vertex sets.

**Theorem 21** ([77]). For every  $k$ , there exists a family of directed graphs  $(D_i)_{i \in \mathbb{N}}$  of treewidth  $k$ , such that  $n(D_i) = k + 2 + i(k + 1)$  and  $f(D_i) \geq (i + 1)(k - 2\lfloor \log(k) \rfloor)$ .

On the other hand, we show that every  $n$ -vertex digraph of treewidth  $k$  has a feedback vertex set of size at most  $\frac{k}{k+3}n$ .

**Theorem 22** ([77]). If  $G$  has treewidth  $k$ , then  $f(G) \leq \frac{k}{k+3}n(G)$ .

## Submitted and published papers

---

Below are the papers that have been submitted to or published in international journals with peer review.

- [5] V. Bartier, L. Bénéteau, M. Bonamy, H. La, and J. Narboni. A note on deterministic zombies. *Discrete Applied Mathematics*, 301:65–68, 2021.
- [77] K. Knauer, H. La, and P. Valicov. Feedback vertex sets in (directed) graphs of bounded degeneracy or treewidth. arXiv:2111.14986, 2021.
- [82] H. La. 2-distance list  $(\Delta + 3)$ -coloring of sparse graphs. arXiv:2105.01684, 2021.
- [83] H. La, B. Lužar, and K. Štorgel. Further extensions of grötzsch theorem. *Discrete Mathematics*, 345(6):112849, 2022.
- [84] H. La and M. Montassier. 2-distance 4-coloring of planar subcubic graphs with girth at least 21. arXiv:2106.03587, 2021.
- [85] H. La and M. Montassier. 2-distance  $(\Delta + 1)$ -coloring of sparse graphs using the potential method. arXiv:2103.11687, 2021.
- [86] H. La and M. Montassier. 2-distance  $(\Delta + 2)$ -coloring of sparse graphs. arXiv:2109.11927, 2021.
- [87] H. La and M. Montassier. 2-distance list  $(\Delta + 2)$ -coloring of planar graphs with girth at least 10. arXiv:2109.14499, 2021.
- [88] H. La, M. Montassier, A. Pinlou, and P. Valicov.  $r$ -hued  $(r + 1)$ -coloring of planar graphs with girth at least 8 for  $r \geq 9$ . *European Journal of Combinatorics*, 91, 2021.
- [89] H. La and K. Štorgel. 2-distance, injective, and exact square list-coloring of planar graphs with maximum degree 4. arXiv, 2022.
- [90] H. La and P. Valicov. Computer assisted discharging procedure on planar graphs: application to 2-distance coloring. arXiv:2202.03885, 2022.

# Mục lục

<b>1</b>	<b>Introduction</b>	<b>2</b>
1.1	Definitions and notations . . . . .	2
1.2	Proper coloring . . . . .	4
1.3	2-distance coloring . . . . .	6
1.4	The discharging method . . . . .	12
<b>2</b>	<b>The potential method</b>	<b>17</b>
2.1	Elementary operations with the potential function . . . . .	18
2.2	Structural properties of a minimal counterexample . . . . .	20
2.3	Discharging procedure . . . . .	38
<b>3</b>	<b>Computer assisted discharging procedures</b>	<b>46</b>
3.1	Useful observations and lemmas . . . . .	46
3.2	Structural properties of a minimal counterexample . . . . .	52
3.3	Discharging procedure . . . . .	60
3.4	Generalization of the discharging algorithm . . . . .	68
<b>4</b>	<b>Building planar graphs with high <math>g</math> and <math>\chi^2</math></b>	<b>70</b>
<b>5</b>	<b>Other variants of 2-distance coloring</b>	<b>76</b>
5.1	$r$ -hued coloring . . . . .	76
5.2	Injective and exact square coloring . . . . .	88
<b>6</b>	<b>Conclusion</b>	<b>99</b>
	<b>References</b>	<b>101</b>
	<b>Appendix</b>	<b>108</b>

# Chương 1

## Introduction

We start out with some definitions and an introduction to the motivation behind the study of 2-distance coloring on sparse graphs as well as the discharging method, the main tool that we will be using throughout the thesis.

### 1.1 Definitions and notations

---

A (*simple*) graph  $G$  is a pair  $(V, E)$  of finite sets such that  $E$  is a set of pairs of elements of  $V$ . The elements of  $V$  are called the *vertices* of  $G$ , and the elements of  $E$  are called the *edges* of  $G$ . The set of vertices of a graph  $G$  is denoted by  $V(G)$ . The set of edges of a graph  $G$  is denoted by  $E(G)$ . The *order* of a graph  $G$  is  $|V(G)|$ , the number of elements of  $V(G)$ . The *size* of  $G$  is  $|E(G)|$ .

Consider a graph  $G$  and let  $u$  and  $v$  be two vertices in  $V(G)$ . We also say that  $u$  and  $v$  are two vertices of  $G$ . An edge  $\{u, v\}$ , denoted by  $uv$ , is *incident* to the vertices  $u$  and  $v$ , and these vertices are the *endpoints* of  $uv$ . We say that  $u$  and  $v$  are *adjacent* if they are incident to the same edge. The *neighbors* of  $u$  are the vertices that are adjacent to  $u$ . The set of neighbors of  $u$  is called the *open neighborhood* of  $u$  and is denoted by  $N_G(u)$ . The *closed neighborhood* of  $u$  is  $N_G[u] = N_G(u) \cup \{u\}$ . By default, when we say the neighborhood of  $u$ , we mean the open neighborhood  $N_G(u)$  unless specified otherwise. For all set  $S \subseteq V(G)$ ,  $N_G[S] = \bigcup_{s \in S} N_G[s]$  is the closed neighborhood of  $S$ , and  $N_G(S) = N_G[S] \setminus S$  is the open neighborhood of  $S$ . The *degree* of  $u$  is  $d_G(u) = |N_G(u)|$ . For an integer  $k$ , a *k-vertex*, *k<sup>+</sup>-vertex*, or *k<sup>-</sup>-vertex* denote a vertex with degree  $k$ , at least  $k$ , or at most  $k$  respectively. Similarly, given a vertex  $u$ , a *d-neighbor*, *d<sup>+</sup>-neighbor*, or *d<sup>-</sup>-neighbor* denote a neighbor of  $u$  with degree  $d$ , at least  $d$ , or at most  $d$  respectively. For two integers  $k, l$  with  $k \leq l$  and a vertex  $u$ , a *(k ↔ l)-vertex* (*(k ↔ l)-neighbor*) is a vertex (neighbor of  $u$ ) with degree between  $k$  and  $l$  included. The *minimum degree* of  $G$  is  $\delta(G) = \min_{u \in V(G)} d_G(u)$ . The *maximum degree* of  $G$  is  $\Delta(G) = \max_{u \in V(G)} d_G(u)$ . The *average degree* of  $G$  is  $\text{ad}(G) = \frac{2|E(G)|}{|V(G)|}$ . A graph where every vertex has degree  $d$  is called a *d-regular graph*.

A *subgraph*  $H$  of a graph  $G$  is a graph such that  $V(H) \subseteq V(G)$  and  $E(H) \subseteq E(G)$ . For a set  $S \subseteq V(G)$ , the subgraph *induced* by  $S$  in  $G$  is  $G[S] = (S, E(G) \cap (S \times S))$ . We denote  $G - S$  the graph  $G[V(G) \setminus S]$ . For simplicity, we denote  $G - \{u\}$  by  $G - u$  for a vertex  $u$  of  $G$ . For conciseness, we will also use  $G - s_1 s_2 \dots s_n$  instead of  $G - \{s_1, s_2, \dots, s_n\}$  when there is no ambiguity. For a set  $T \subseteq E(G)$ , we denote  $G - T$  the graph  $(V(G), E(G) \setminus T)$ . Similarly, for simplicity, we denote  $G - \{e\}$  by  $G - e$  for an edge  $e \in E(G)$ . For a set  $T$  of pairs of elements of  $V$  such that  $F \cap E(G) = \emptyset$ , we define  $G + T = (V(G), E(G) \cup T)$ . Sometimes, we abuse this previous notation when we add a set of vertices  $S$  to  $G$  by writing  $G + S$ ; in such a case, we define exactly the edges that are added to  $G$ . The *maximum average degree* of  $G$ , denoted by  $\text{mad}(G)$ , is the maximum over  $\text{ad}(H)$  for all  $H$  subgraph of  $G$ .

A *path*  $P$  in  $G$  is a sequence of distinct vertices  $u_0, u_1, \dots, u_{k+1}$  such that  $u_i u_{i+1}$  is an edge for every  $0 \leq i \leq k$ . The vertices  $u_0$  and  $u_{k+1}$  are called the *endvertices* of  $P$ . A *d-endvertex*, *d<sup>+</sup>-*

*endvertex*, or  $d^-$ -*endvertex* denote an endvertex with degree  $d$ , at least  $d$ , or at most  $d$  respectively. The vertices  $u_i$  for  $1 \leq i \leq k$  are the *inner vertices* of  $P$ . The *length of a path* is  $k + 1$  if it has  $k$  inner vertices. The graph consisting of only one path of length  $k$  is denoted by  $P_k$ . The *distance* between two vertices  $u$  and  $v$  is the length of a *shortest path* (i.e. path with minimum length) with endvertices  $u$  and  $v$ . A graph  $G$  is *connected* if there exists a path between every pair of vertices of  $G$ . The *components* of a graph are its maximum connected subgraphs. The maximum distance in a connected graph is called the *diameter* of the graph. A path is a *thread* when the inner vertices are all 2-vertices. For an integer  $k$ , a  $k$ -*thread*,  $k^+$ -*thread*, or  $k^-$ -*thread* denote a thread with exactly  $k$ , at least  $k$ , or at most  $k$  inner vertices respectively. A  $(k_1, k_2, \dots, k_d)$ -*vertex* is a  $d$ -vertex that is incident with  $d$  different threads where the  $i$ th thread is a  $k_i$ -thread for all  $1 \leq i \leq d$ . A *cycle*  $C$  in  $G$  is a sequence of distinct vertices  $u_1, u_2, \dots, u_k$  such that  $u_i u_{i+1}$  is an edge for every  $0 < i < k$  and  $u_1 u_k$  is an edge. For an integer  $k \geq 3$ , a  $k$ -*cycle*,  $k^+$ -*cycle*, or  $k^-$ -*cycle* denote a cycle on exactly  $k$ , at least  $k$ , or at most  $k$  vertices respectively. The *length of a  $k$ -cycle* is  $k$ . The graph consisting of only one  $k$ -cycle is denoted by  $C_k$ . The *girth* of  $G$ , denoted by  $g(G)$ , is the length of its smallest cycle.

An *independent set* (resp. a *clique*) of a graph  $G$  is a set of vertices such that no (resp. every) pair of vertices are adjacent to one another. The size of the biggest independent set (resp. clique) of  $G$  is denoted  $\alpha(G)$  (resp.  $\omega(G)$ ). A graph whose set of vertices is a clique is a *complete graph*. For an integer  $k \geq 1$ , the complete graph on  $k$  vertices is denoted by  $K_k$ . A graph is *bipartite* if its set of vertices can be partitioned into two disjoint sets  $A$  and  $B$  where every edge has exactly one endpoint in  $A$  (the other is in  $B$ ). A *forest* is a graph with no cycles. The girth of a forest is considered to be infinite. A *tree* is a connected forest. A *rooted tree* is a tree where exactly one vertex is called the *root* of the tree. In a rooted tree, we can define a parent-children relationship recursively between two adjacent vertices. The root is the *parent* of all of its neighbors. Once a vertex  $u$  has a parent  $v$ ,  $u$  is called the *child* of  $v$  and  $u$  is in turn the parent of all vertices in  $N(u) \setminus \{v\}$ . The *grandparent* (resp. a *grandchild*) of a vertex in a rooted tree is the parent of its parent (resp. a child of one of its child). These notions are well-defined in a tree since there are no cycles.

Let  $k \geq 1$  be an integer. A  $k$ -*coloring*  $\phi$  of a graph  $G$  is a function from  $V(G)$  to the set of integers  $\{1, 2, \dots, k\}$ , called set of colors, that assigns to each vertex of  $V(G)$  a color from  $\{1, 2, \dots, k\}$ . A coloring also defines a natural vertex partition of  $V(G)$  into disjoint sets called *color classes*. A *proper coloring* is a coloring where every color class is an independent set. For an integer  $d \geq 1$ , a  $d$ -*distance coloring* is a coloring where each color class is a set of vertices where every pair of vertices are at distance at least  $d + 1$  from one another. Hence proper coloring corresponds to 1-distance coloring. The *chromatic number* of a graph  $G$ , denoted by  $\chi(G)$ , is the smallest integer  $k$  such that  $G$  has a proper  $k$ -coloring. The  $d$ -*distance chromatic number* of  $G$ , denoted by  $\chi^d(G)$ , is the smallest integer  $k$  such that  $G$  has a  $d$ -distance  $k$ -coloring. Given a graph  $G$ , a *list assignment*  $L$  is a function that maps each vertex  $u \in V(G)$  to a *list of colors*  $L(u)$  which is a set of integers. We say that  $G$  is  *$L$ -list-colorable* or  *$L$ -choosable* if there exists a proper coloring  $\phi$  of  $G$  such that  $\phi(u) \in L(u)$  for all  $u \in V(G)$ . A  $k$ -list assignment is a list assignment  $L$  where  $|L(v)| \geq k$  for every vertex  $v \in V(G)$ . If  $G$  is colorable for every  $k$ -list assignment, then we say that  $G$  is  *$k$ -list-colorable* or  *$k$ -choosable*. The *list chromatic number* or *choice number* of a graph  $G$ , denoted by  $\chi_\ell(G)$ , is the smallest integer  $k$  such that  $G$  is  $k$ -choosable. The notion of  $d$ -distance colorings can be extended to a list version. We say that  $G$  is  *$d$ -distance  $k$ -list-colorable* or  *$d$ -distance  $k$ -choosable* if for every  $k$ -list assignment  $L$ , there exists a  $d$ -distance coloring  $\phi$  of  $G$  such that  $\phi(u) \in L(u)$  for all  $u \in V(G)$ . The  $d$ -*distance list chromatic number* of  $G$ , denoted by  $\chi_\ell^d(G)$ , is the smallest integer  $k$  such that  $G$  has a  $d$ -distance  $k$ -list-coloring.

A notion that is closely related to distance coloring is the power of graphs. We denote by  $G^d$ , the  $d$ th *power* of  $G$ , the graph on  $V(G)$  where  $u$  and  $v$  are adjacent if they are at distance at most  $d$  in  $G$  for all  $u$  and  $v$  in  $V(G)$ . Given a graph  $G$  and a type of coloring (for example a  $d$ -distance coloring), we can define the *conflict graph* of  $G$  as the graph with the same vertices of  $V(G)$  and



there exists an edge between two vertices  $u$  and  $v$  if they must have different colors. Observe that the conflict graph of  $G$  for a proper coloring is  $G$  itself. The conflict graph of  $G$  for a 2-distance coloring is  $G^2$ , also called the *square* of  $G$ . In general, the conflict graph of  $G$  for a  $d$ -distance coloring  $G^d$ . We say that two vertices of  $G$  *see* each other in a type of coloring if they are adjacent in the corresponding conflict graph.

Since we are paying special attention to 2-distance coloring, we will also define the following notions. Given a graph  $G$ , for each vertex  $u \in V(G)$ , the *2-distance (open) neighborhood* of  $v$ , denoted by  $N_G^*(v)$ , is the set of vertices at distance at most 2 from  $v$  not including  $v$ . We also define  $d_G^*(v) = |N_G^*(v)|$ .

Each graph has an *embedding* on a surface where its vertices can be represented with distinct points and its edges with curves between its endpoints. A graph is *planar* if it has an embedding on the plane where its edges only intersect at their endpoints. A *plane graph* is a planar embedding of a planar graph. In a plane graph, a *face*  $f$  is a maximum connected surface that do not contain any edges or vertices. The set of edges and vertices that are in contact with  $f$  is the *boundary* of  $f$ . Vertices and edges in the boundary of  $f$  are *incident* to  $f$ . Two faces are adjacent if their boundaries share an edge. The *degree of a face*  $f$ , denoted by  $d(f)$ , is the number of edges in its boundary and the edges that are not in the boundary of any other faces are counted twice. A  $d$ -face,  $d^+$ -face, or  $d^-$ -face denote a face with degree  $d$ , at least  $d$ , or at most  $d$  respectively. The set of faces of a graph  $G$  is denoted by  $F(G)$ . For convenience, starting now, we will identify a face  $f$  with its boundary. Of course, this definition of a face also holds for surfaces other than a plane but for this thesis, we are concentrating on plane graphs.

For all of the notations defined above, we will drop the subscript and/or the argument when it is clear from context. And for general drawing conventions, black vertices will have their degree represented and white vertices may have a higher degree than what is drawn unless specified otherwise. Some figures will also contain extra information, in which case, their meaning will be specified.

## 1.2 Proper coloring

---

When talking about graph coloring, one has to mention the famous Four Color Theorem.

**Theorem 1.1** (Appel *et al.* [3, 4]). Every planar graph is 4-colorable.

This theorem started as a conjecture by Francis Guthrie in 1852 who was trying to color a map of English counties such that no regions sharing a border can be colored the same. This question was brought, by Francis' brother, to the attention of De Morgan and subsequently the mathematical community at large. Many attempted to prove this conjecture but failed. One such famous attempt was due to Kempe in 1879 and for a decade, the Four Color Conjecture was accepted as the Four Color Theorem. However, in 1890, it returned to being a conjecture when Heawood pointed out an error in Kempe's proof but his method was still valid to prove that any planar graph is 5-colorable. This problem remained open for almost a century until 1976 when it was proven by Appel *et al.* [3, 4] using the discharging method with computer assistance. In 1997, Robertson *et al.* simplified the proof using the same method [104]. Later on, this proof was verified by Gonthier using Coq [61].

The Four Color Conjecture and in turn the Four Color Theorem motivated a lot of research in graph colorings and also popularized the discharging method.

For proper colorings, we have the following upper bound for any graph  $G$ :  $\chi(G) \leq \Delta(G) + 1$ . This upper bound is trivial as one can color the vertices greedily by picking for a vertex, a color that is not present in its neighborhood. This bound is easily reached for any graph  $G$  containing a clique of size  $\Delta(G) + 1$ . A more refined version of this upper bound is Brooks' Theorem.

**Theorem 1.2** (Brooks [22]). Every connected graph  $G$  satisfies  $\chi(G) \leq \Delta(G)$  excepted when  $G = K_{\Delta(G)+1}$  or  $G$  is an odd cycle for which  $\Delta(G) + 1$  colors are necessary.

The upper bound in Brooks' Theorem is also reached for an infinite amount of graphs (any graph containing a clique of size  $\Delta$ ). Intuitively, the "proper constraint" means that the chromatic number of a graph depends on the number of vertices in the neighborhood of every vertex. This was illustrated above by the upper bound using the maximum degree. Thus, the question of coloring "sparser" graphs comes very naturally.

### Proper coloring in sparse graphs

An initial observation one can have is that the maximum degree might not be a good measure of the "density" of the graph as it might only have one vertex with very high degree for example. A slightly better measure of "sparseness" is the average degree which is simply a ratio of number edges over number of vertices in the graph. One can be even more precise with the maximum average degree which guarantees a better "distribution" of the edges (avoiding cases where there is a "dense" subgraph and a very sparse rest of the graph which decreases the average degree). This intuition is confirmed by the following result by Szekeres and Wilf.

**Theorem 1.3** (Szekeres, Wilf [112]). Let  $G$  be a graph and  $\lambda(G)$  be any real valued function on  $G$  with the following properties:

- $\lambda(G) \geq \delta(G)$ .
- For any subgraph  $H$  of  $G$ ,  $\lambda(H) \leq \lambda(G)$ .

Then,  $\chi(G) \leq \lambda(G) + 1$ .

The maximum average degree clearly verifies the two properties of  $\lambda$  in Theorem 1.3. Thus, we have the following corollary.

**Corollary 1.4.** For every graph  $G$ ,  $\chi(G) \leq \text{mad}(G) + 1$ .

In this sense, the class of planar graphs is the most famous class of sparse graphs. Intuitively, the constraint of not having edge crossings in a planar drawing of the graph limits the number of edges you can have given the number of vertices. Euler's formula quantifies this sparseness exactly using an object that is specific to graphs that are embeddable on surfaces without edges crossing: its faces. Euler's formula applied to a connected plane graph  $G$  says:

$$|V(G)| + |F(G)| - |E(G)| = 2. \tag{1.1}$$

This equation means that the number of edges is basically equal to the number of vertices and faces in a connected planar graph  $G$ . One intuitive way to understand this equation is by drawing  $G$  starting with the vertices. Then, whenever we draw a new edge between two vertices, we either visit a new vertex or close off a region which becomes a new face.

Using Euler's formula, when  $|V(G)| \geq 3$ , the fact that every face of a planar graph has degree at least 3 (as we only consider simple graphs), and that  $\sum_{f \in F(G)} d(f) = 2|E(G)|$ , we can deduce that  $|E(G)| \leq 3|V(G)| - 6$ . This yields an average degree less than 6 and the same holds for the maximum average degree as any subgraph of a planar graph is also planar by definition. In other words, on average, a vertex in a planar graph has less than 6 neighbors.

While a planar graph can have an arbitrary maximum degree, its bounded maximum average degree drops the upper bound on the chromatic number from  $\Delta + 1$  to at most 7 by Corollary 1.4. The Four Color Theorem suggests that there exists something more than just bounded maximum average degree ( $\text{mad} < 6$ ) for planar graphs since we drop from 7 to 4 colors. Moreover,  $K_5$  is a non-planar graph ( $|E(K_5)| = 10 > 3|V(K_5)| - 6 = 9$ ) with  $\chi(K_5) = \text{mad}(K_5) + 1 = 5 < 6$ . So, even though bounding maximum average degree is a good way to decrease the chromatic number, planar graphs contain more structural properties than just bounded  $\text{mad}$ .

## Proper list-coloring

Another recurring notion of coloring throughout this thesis is list-coloring. Since a proper coloring is a proper list-coloring where every list is the same, we obtain the following inequality:

$$\chi(G) \leq \chi_\ell(G).$$

At first glance, it is unclear that  $\chi_\ell$  can be much larger than  $\chi$  as one might think that it is easier to obtain a proper coloring if our vertices have very different list of colors. However, Erdős *et al.* showed that the gap between the chromatic number and the choice number can be arbitrarily large.

**Theorem 1.5** (Erdős *et al.* [55]). For every integer  $k$ , there exists a bipartite graph  $G$  with  $\chi_\ell(G) \geq k$ .

By definition, a bipartite graph is 2-colorable where the two classes of colors constitutes the partition of the set of vertices. However, Theorem 1.5 shows that we can obtain a very large choice number despite the graph being 2-colorable.

For planar graphs, Vizing conjectured that every planar graph is 5-choosable in 1975, and this statement was proved by Thomassen in 1994:

**Theorem 1.6** (Thomassen [113]). Every planar graph is 5-choosable.

Theorem 1.6 along with the Four Color Theorem implies that we have a gap of at most 1 between the chromatic and the choice number for planar graphs. This gap was confirmed to be exactly 1 around the same time. In 1979, Erdős *et al.* conjectured that there are planar graphs which are not 4-choosable and this was proven by Voigt in 1993.

**Theorem 1.7** (Voigt [115]). There exists a planar graph  $G$  with  $\chi_\ell(G) \geq 5$ .

## 1.3 2-distance coloring

---

In 1969, Kramer and Kramer introduced the notion of  $d$ -distance coloring [80, 81] for an integer  $d \geq 1$ . This notion generalizes proper coloring which can be seen as 1-distance coloring. Throughout the years, an extensive amount of research has been done on distance coloring, most of which concentrated on the first interesting case after  $d = 1$ , which is naturally 2-distance coloring, one of the focus this thesis.

Similarly to proper coloring, one can also bound the 2-distance chromatic number by using the maximum degree of the graph. Observe that, for any graph  $G$ ,  $\Delta(G) + 1 \leq \chi^2(G) \leq \Delta(G)^2 + 1$ . The lower bound is trivial since, in a 2-distance coloring, every neighbor of a vertex  $v$  with degree  $\Delta$ , and  $v$  itself must have a different color. For the upper bound, a greedy coloring algorithm shows that  $\chi^2(G) \leq \Delta(G)^2 + 1$ , i.e. it suffices to color a vertex differently from every colored vertex in its 2-distance neighborhood which is of size at most  $\Delta(G)^2$ . This bound is reached by Moore graphs of type  $(\Delta, 2)$ , which are  $\Delta$ -regular graphs with diameter 2 and  $\Delta^2 + 1$  vertices. In other words, Moore graphs are the graphs whose square are complete graphs. For example, the cycle  $C_5$  and the Petersen graph are graphs of type  $(2, 2)$  and  $(3, 2)$  respectively (See Figure 1.1).

However, Hoffman and Singleton proved that there exists only a finite number of such graphs [71]. Similar to Brooks' Theorem for proper coloring, there exist Brooks-like results for powers of graphs [102] showing that the number of graphs reaching this trivial upper bound is finite for a given power and maximum degree. For the case of 2-distance coloring, Cranston and Rabern proved the following.

**Theorem 1.8** (Cranston, Rabern [39]). If  $G$  is not a Moore graph, then  $\chi^2(G) \leq \Delta(G)^2 - 1$ .

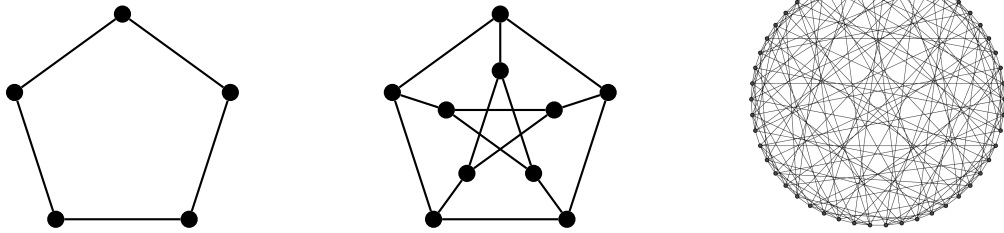

(i) The Moore graph of type (2,2): the odd cycle  $C_5$ . (ii) The Moore graph of type (3,2): the Petersen graph. (iii) The Moore graph of type (7,2): the Hoffman-Singleton graph.

Hình 1.1: Examples of Moore graphs for which  $\chi^2 = \Delta^2 + 1$ .

While there is a finite number of graphs reaching the trivial upper bound, McKay *et al.* built a family of graphs of diameter 2 of order  $\frac{8}{9}(\Delta + 12)^2$  [97] for an infinite number of  $\Delta$ . Any graph containing such subgraphs will have a 2-distance chromatic number that is quadratic in the maximum degree.

### 2-distance choosability

As a 2-distance coloring is also a proper coloring of the square, we have  $\chi^2(G) = \chi(G^2)$ . The same can be said for list coloring. Thus, we also have the same inequality between the 2-distance chromatic number and the 2-distance choice number:

$$\chi^2(G) \leq \chi_\ell^2(G).$$

Given what we know about the gap between the chromatic number and the choice number, one might suspect that the same will hold for their 2-distance version. However, it is unclear that this is true as constructions of bipartite graphs like in Theorem 1.5 fail when we consider a coloring of the square of the graph. In 2001, Kostoshka and Woodall even conjectured that these two numbers are one and the same [79]. This was known as the List Square Coloring Conjecture. In 2013, Kim and Park gave infinitely many counterexamples to the conjecture, going as far as showing that  $\chi_\ell^2 - \chi^2$  can be arbitrarily large.

**Theorem 1.9** (Kim, Park [74]). For every prime number  $p \geq 3$ , there exists a graph  $G$  such that  $\chi_\ell^2(G) - \chi^2(G) \geq p - 1$ .

While we also get a big gap between the choice number and the chromatic number for 2-distance coloring, the construction proposed in [74] is very dense and is far from being planar. Up to our knowledge, the List Square Coloring Conjecture is still open for planar graphs.

### 2-distance coloring of sparse graphs

Corollary 1.4, which gives a Brooks-like result for proper coloring, bounds the chromatic number in terms of the maximum average degree. This justifies the intuition of studying sparser graphs. However, we do not have an equivalent version for 2-distance coloring. Indeed, a tree, which has  $\text{mad} < 2$ , can have an arbitrarily large maximum degree and thus an arbitrarily large 2-distance chromatic number ( $\chi^2 \geq \Delta + 1$ ) compared to the maximum average degree.

Despite this observation, in 1977, Wegner conjectured that  $\chi^2(G)$  becomes linear in  $\Delta(G)$  for a planar graph  $G$ .

**Conjecture 1.10** (Wegner [117]). Let  $G$  be a planar graph with maximum degree  $\Delta$ . Then,

$$\chi^2(G) \leq \begin{cases} 7, & \text{if } \Delta \leq 3, \\ \Delta + 5, & \text{if } 4 \leq \Delta \leq 7, \\ \lfloor \frac{3\Delta}{2} \rfloor + 1, & \text{if } \Delta \geq 8. \end{cases}$$

These conjectured upper bounds would be tight due to the constructions in Figures 1.2 and 1.3. Recently, the case  $\Delta \leq 3$  was proved by Thomassen [114], and by Hartke *et al.* [66] independently. For  $\Delta \geq 8$ , Havet *et al.* [68] proved that the bound is  $\frac{3}{2}\Delta(1 + o(1))$ , where  $o(1)$  is as  $\Delta \rightarrow \infty$  (this bound even holds for 2-distance list-colorings). These results confirmed the intuition for sparse graphs where the upper bound on  $\chi^2$  dropped by a factor of  $\Delta$ .

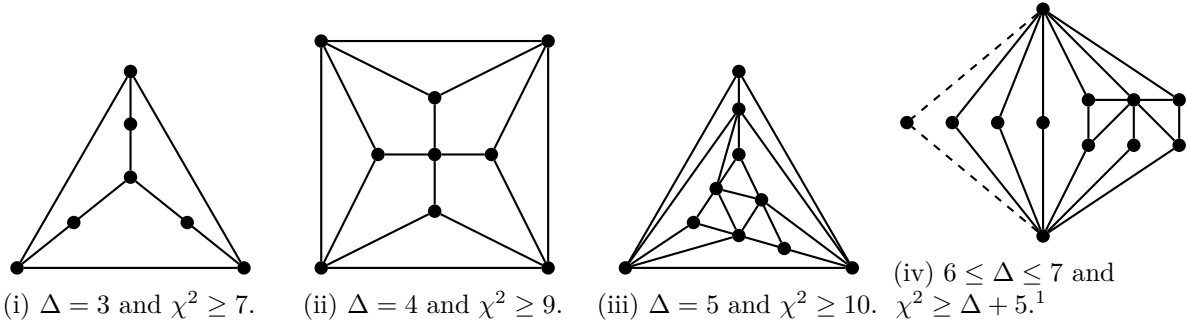

Hình 1.2: Constructions by Wegner in [117].

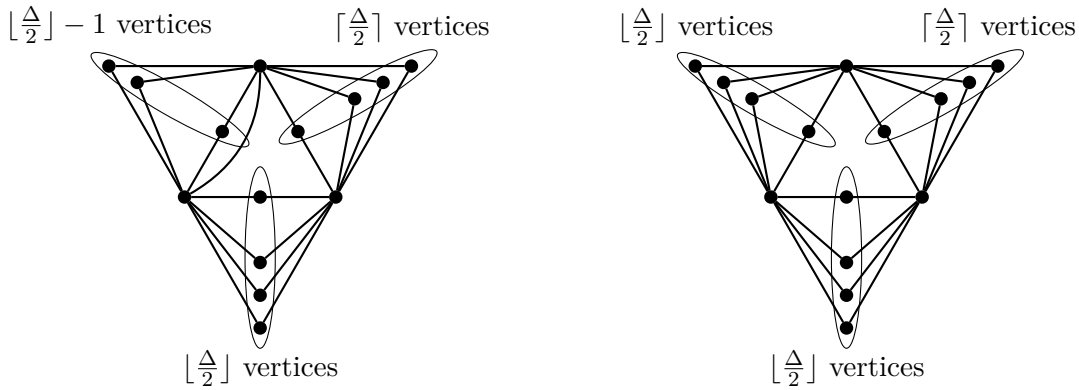

(i) A graph with girth 3 and  $\chi^2 = \lfloor \frac{3\Delta}{2} \rfloor + 1$  (drawn for  $\Delta = 8$ ).

(ii) A graph with girth 4 and  $\chi^2 = \lfloor \frac{3\Delta}{2} \rfloor$  (drawn for  $\Delta = 8$ ).

Hình 1.3: Graphs with  $\chi^2 \approx \frac{3}{2}\Delta$  [117].

While planarity seems to not be reduced to bounded maximum average degree in the case of proper coloring, the same is not trivial for 2-distance coloring. However, we can also show that structural properties of planar graphs, even when “squared”, contributes more than just bounded mad. Indeed, consider the Petersen graph where we remove one vertex. The resulting graph has  $\Delta = 3$ ,  $\text{mad} = \frac{8}{3}$  and  $\chi^2 = 8$  while it was proven that planar graphs with  $\Delta = 3$  are 2-distance 7-colorable. Moreover, the graph in Figure 1.2(i) where we add an edge between two 2-vertices is planar, has  $\Delta = 3$ ,  $\text{mad} = \frac{20}{7} > \frac{8}{3}$ , and  $\chi^2 = 7$ . This seems to indicate that we need to exploit the difference between planar graphs and general graphs with bounded mad. One such difference is the presence of faces. This is one of the driving ideas of results that will be discussed in this thesis.

<sup>1</sup>The dashed edges are included for  $\Delta = 7$  and are not for  $\Delta = 6$ .

Although the passage from general to planar graphs decreased the quadratic bound to a linear bound in  $\Delta$ , there is still a gap between the lower bound of  $\Delta + 1$  and the upper bound of  $\lfloor \frac{3}{2}\Delta \rfloor + 1$ . The study of graph classes that fit in this gap became an extensive field of research in 2-distance coloring (see Table 1.1). The most natural next step in this direction is to decrease the maximum average degree even further, or alternatively restrict the class of planar graphs by increasing its girth, to obtain sparser graphs. Intuitively, in a planar graph, the higher the girth is, the further away the vertices are from one another. This intuition is quantifiable through Proposition 1.11, which also links the two measures of sparseness, girth and mad, in the case of planar graphs: the higher the girth of our planar graph is, the smaller its mad is.

**Proposition 1.11** (Folklore). For every connected planar graph  $G$  with finite girth,  $(\text{mad}(G) - 2)(g(G) - 2) < 4$ .

*Chứng minh.* Let  $H$  be a subgraph of  $G$  such that  $\text{mad}(G) = \text{ad}(H) = \frac{2|E(H)|}{|V(H)|}$ . Euler's formula states that:  $|E(H)| - |V(H)| + 2 = |F(H)|$ . Since

$$\begin{aligned} \sum_{f \in F(H)} g(H) &\leq \sum_{f \in F(H)} d(f) \\ |F(H)|g(H) &\leq 2|E(H)| \\ |F(H)| &\leq \frac{2|E(H)|}{g(H)} \end{aligned}$$

We have

$$\begin{aligned} |E(H)| - |V(H)| &< \frac{2|E(H)|}{g(H)} \\ \frac{2g(H)}{|V(H)|}|E(H)| - 2g(H) &< \frac{4|E(H)|}{|V(H)|} \\ \text{mad}(G)g(H) - 2g(H) &< 2\text{mad}(G) \\ \text{mad}(G)g(H) - 2g(H) - 2\text{mad}(G) + 4 &< 4 \\ (\text{mad}(G) - 2)(g(H) - 2) &< 4 \end{aligned}$$

Since  $g(H) \geq g(G)$  and  $\text{mad}(G) - 2 > 0$  as  $G$  has finite girth,  $(\text{mad}(G) - 2)(g(G) - 2) < 4$ .  $\square$

One might think that a high girth plays a big role in the sparseness of the graph but the proof of Proposition 1.11 relies heavily on Euler's formula, in other words, the planarity of the graph. In fact, in 1959, Erdős already proved that there is no relationships between the chromatic number and the girth of the graph in the general case.

**Theorem 1.12** (Erdős [54]). For every integers  $k$  and  $l$ , there exists a graph  $G$  with  $g(G) \geq k$  and  $\chi(G) \geq l$ .

Theorem 1.12 implies that a high girth alone does not suffice to decrease the mad of a graph or it would contradict Corollary 1.4.

Before moving on, we will take a look at some easy cases. Proposition 1.11 only holds for graphs with finite girth. To be exhaustive, we turn our attention to graphs with infinite girth, which are forests by definition. In this case, their 2-distance chromatic number reaches the minimum possible value.

**Proposition 1.13.** For every forest  $T$ ,  $\chi^2(T) = \Delta(T) + 1$ .

*Chứng minh.* Suppose by contradiction that there exists a vertex-minimal forest  $T$  for which  $\chi^2(T) \geq \Delta(T) + 2$ . Since  $T$  is a forest, there exists a 1-vertex  $t$ . We can color  $T - t$  with  $\Delta(T) + 1$  colors by the minimality of  $T$ . We can extend this coloring to  $t$  by choosing a color that does

not appear in its 2-distance neighborhood. This is possible as  $t$  only sees at most  $\Delta(T)$  colored vertices. Thus, we obtain a 2-distance  $\Delta(T) + 1$ -coloring of  $T$ , which is a contradiction. So, for every forest  $T$ ,  $\chi^2(T) \leq \Delta(T) + 1$ . Combining this with the lower bound on  $\chi^2$  for every graph, we obtain the desired result.  $\square$

The case when  $\Delta = 2$  is also easily solved by Proposition 1.14 and its upper bound is reached by  $C_5$ .

**Proposition 1.14.** For every graph  $G$  with  $\Delta(G) \leq 2$ ,  $\chi^2(G) \leq 5$ .

*Chứng minh.* Suppose by contradiction that there exists a vertex-minimal graph  $G$  with  $\Delta(G) \leq 2$  and  $\chi^2(G) \geq 6$ . If  $G$  is a forest, then  $\chi^2(G) \leq 3$  due to the previous proposition. Thus,  $G$  is a cycle as it is connected by minimality. However, there is a contradiction as every cycle is 2-distance 5-colorable.

Indeed, we argue by induction on the order of the cycle. If a cycle  $C$  has at most 5 vertices, then  $\chi^2(C) \leq 5$ . Now consider a cycle  $C$  with at least 6 vertices, we remove one vertex  $u$  and connect its two neighbors with an edge. By induction hypothesis, there exists a 2-distance 5-coloring  $\psi$  of that smaller cycle. Now, we define the following coloring  $\phi$  for  $C$ . For every vertex  $v$  of  $C - u$ , we choose  $\phi(v) = \psi(v)$  and for  $\phi(u)$  we choose a color that does not appear in its 2-distance neighborhood. This is possible since we have 5 colors and  $d^*(u) = 4$ . Moreover, since  $\psi$  is a 2-distance 5-coloring of  $C - u$  where we added an edge between the neighbors of  $u$ ,  $\phi$  is a 2-distance 5-coloring of  $C$  by construction.  $\square$

To fill the gap between  $\Delta + 1$  and  $\lfloor \frac{3}{2}\Delta \rfloor + 1$ , many results are of the following form: *every graph  $G$  of  $\text{mad}(G) \leq m_0$  and  $\Delta(G) \geq \Delta_0$  satisfies  $\chi^2(G) \leq \Delta(G) + c(m_0, \Delta_0)$  where  $c(m_0, \Delta_0)$  is a small constant depending only on  $m_0$  and  $\Delta_0$* . Moreover, for a planar graph  $G$ , any theorem with an upper bound on  $\text{mad}(G)$  can be translated to a theorem with a lower bound on  $g(G)$  thanks to Proposition 1.11. More precisely, planar graphs with girth at least  $g$  has  $\text{mad} < \frac{2g}{g-2}$ . Thus, as a corollary, we have the same results on planar graphs of girth  $g \geq g_0(m_0)$  where  $g_0$  depends on  $m_0$ . Table 1.1 shows the state of the art (of positive and negative results), up to our knowledge, on the 2-distance chromatic number of planar graphs with fixed girth, either proven directly for planar graphs with high girth or came as a corollary of a result on graphs with bounded maximum average degree.

The positive results in Table 1.1 are read as follows. For example, the result from line “7” and column “ $\Delta + 1$ ” reads: “*every planar graph  $G$  of girth at least 7 and of maximum degree  $\Delta$  at least 16 satisfies  $\chi^2(G) \leq \Delta + 1$* ”.

Below, we list all of the negative results corresponding to the crossed out cases in Table 1.1.

- Girths 3 to 6 in column “ $\Delta + 1$ ” correspond to Proposition 1.15.
- Girth 11 in column “ $\Delta + 1$ ” correspond to Proposition 1.16.
- Girths 3 and 4 in column “ $\Delta + 2$ ” correspond to Proposition 1.17.
- Girths 5 and 6 in column “ $\Delta + 2$ ” correspond to Propositions 1.18 and 1.19.
- Girth 3 in column “ $\Delta + 3$ ” correspond to Figure 1.2(i).
- Girth 3 in column “ $\Delta + 4$ ” correspond to Figures 1.2 and 1.3.
- The remaining crossed out values in rows “3” and “4” correspond to Figure 1.3.

Every highlighted result in Table 1.1 are part of our contribution to this field of research.



$\chi^2(G)$	$\Delta + 1$	$\Delta + 2$	$\Delta + 3$	$\Delta + 4$	$\Delta + 5$	$\Delta + 6$	$\Delta + 7$	$\Delta + 8$
$g_0$								
3				$\Delta = 3$ [114, 66] $\Delta \geq 4^{2 \cdot 3}$	$\Delta \geq 10^3$	$\Delta \geq 12^3$	$\Delta \geq 14^3$	$\Delta = 4$ [18] $\Delta \geq 16^3$
4			$\Delta \geq 8^4$	$\Delta \geq 10^4$	$\Delta \geq 12^4$	$\Delta \geq 14^4$	$\Delta = 4$ [89] $\Delta \geq 16^4$	$\Delta \geq 18^4$
5		$\Delta \geq 10^7$ [6] <sup>6</sup> $\Delta = 4$ [87]	$\Delta \geq 339$ [48]	$\Delta \geq 312$ [47]	$\Delta \geq 15$ [26] <sup>5</sup>	$\Delta \geq 12$ [25] <sup>6</sup>	$\Delta \neq 7, 8$ [47]	$\Delta \geq 3$ [46]
6		$\Delta \geq 17$ [8] <sup>8</sup> $\Delta = 3$ [90]	$\Delta \geq 9$ [25] <sup>6</sup>		$\Delta \geq 3$ [28]			
7	$\Delta \geq 16$ [72] <sup>6</sup>	$\Delta \geq 10$ [86] <sup>8</sup>	$\Delta \geq 6$ [82] <sup>7</sup>	$\Delta = 4$ [36] <sup>7</sup>				
8	$\Delta \geq 9$ [88] <sup>5</sup>	$\Delta \geq 6$ [86] <sup>8</sup>	$\Delta \geq 3$ [90]					
9	$\Delta \geq 7$ [85] <sup>8</sup>	$\Delta \geq 5$ [24] <sup>7</sup>						
10	$\Delta \geq 6$ [72] <sup>6</sup>	$\Delta \geq 4$ [87]						
11	$\Delta = 3$ [84]							
12	$\Delta \geq 5$ [72] <sup>6</sup>	$\Delta \geq 3$ [16] <sup>6</sup>						
13								
14	$\Delta \geq 4$ [7] <sup>8</sup>							
...								
21	$\Delta \geq 3$ [84]							

Bảng 1.1: The latest results with a coefficient 1 before  $\Delta$  in the upper bound of  $\chi^2$ .

Below are the statements of our (positive) results, some are proven for larger graph classes (bounded mad instead of planar graphs with high girth) or for the list version of the problem.

[84] If $G$ is a planar graph with $g(G) \geq 21$ , then $\chi^2(G) \leq \Delta(G) + 1$ for $\Delta(G) \geq 3$ .
[85] If $G$ is a graph with $\text{mad}(G) < \frac{18}{7}$ , then $\chi^2(G) \leq \Delta(G) + 1$ for $\Delta(G) \geq 7$ .
[88] If $G$ is a planar graph with $g(G) \geq 8$ , then $\chi^2(G) \leq \Delta(G) + 1$ for $\Delta(G) \geq 9$ .
[87] If $G$ is a planar graph with $g(G) \geq 10$ , then $\chi^2(G) \leq \Delta(G) + 2$ for $\Delta(G) \geq 4$ .
[86] If $G$ is a graph with $\text{mad}(G) < \frac{8}{3}$ , then $\chi^2(G) \leq \Delta(G) + 2$ for $\Delta(G) \geq 6$ .
[86] If $G$ is a graph with $\text{mad}(G) < \frac{14}{5}$ , then $\chi^2(G) \leq \Delta(G) + 2$ for $\Delta(G) \geq 10$ .
[90] If $G$ is a graph with $g(G) \geq 8$ , then $\chi^2(G) \leq \Delta(G) + 3$ for $\Delta(G) \geq 3$ .
[82] If $G$ is a graph with $\text{mad}(G) < \frac{8}{3}$ , then $\chi_\ell^2(G) \leq \Delta(G) + 3$ for $\Delta(G) \geq 4$ .
[82] If $G$ is a graph with $\text{mad}(G) < \frac{14}{5}$ , then $\chi_\ell^2(G) \leq \Delta(G) + 3$ for $\Delta(G) \geq 6$ .
[89] If $G$ is a planar graph with $g(G) \geq 4$ and $\Delta(G) = 4$ , then $\chi_\ell^2(G) \leq \Delta(G) + 7$ .

These results were proven using the discharging method for which the basics will be presented in Section 1.4. In Chapter 2 and Chapter 3, we will present some of these results that will highlight more interesting ideas and nuances in 2-distance coloring as well as the discharging method in general. However, every proof will be available in their corresponding articles in the Appendixes.

In Chapter 4, we will discuss the negative results presented below along with their implications on the hardness of some related decision problems. Finally, in Chapter 5, we will present some variants of 2-distance colorings along with our contributions.

<sup>2</sup>Figure 1.2

<sup>3</sup>Figure 1.3(i)

<sup>4</sup>Figure 1.3(ii)

<sup>5</sup>Corollaries of more general colorings of planar graphs.

<sup>6</sup>Corollaries of 2-distance list-colorings of planar graphs.

<sup>7</sup>Corollaries of 2-distance list-colorings of graphs with a bounded maximum average degree.

<sup>8</sup>Corollaries of 2-distance colorings of graphs with a bounded maximum average degree.



**Proposition 1.15** (Dvořák *et al.* [51]). For every integer  $d \geq 2$ , there exists a planar graph  $G$  with  $g(G) = 6$ ,  $\Delta(G) = d$ , and  $\chi^2(G) \geq d + 2$ .

**Proposition 1.16** ([84]). There exists a planar graph  $G$  with  $g(G) \geq 11$ ,  $\Delta(G) = 3$ , and  $\chi^2(G) \geq \Delta(G) + 2$ .

**Proposition 1.17** ([87]). There exists a planar graph  $G$  with  $g(G) \geq 4$  and  $\chi^2(G) \geq \Delta(G) + 3$ .

**Proposition 1.18** ([87]). There exists a planar graph  $G$  with  $g(G) \geq 5$ ,  $\Delta(G) = 4$ , and  $\chi^2(G) \geq \Delta(G) + 3$ .

**Proposition 1.19** ([90]). There exists a planar graph  $G$  with  $g(G) \geq 6$ ,  $\Delta(G) = 3$ , and  $\chi^2(G) \geq \Delta(G) + 3$ .

## 1.4 The discharging method

---

The method that is employed to obtain almost all upperbounds in Table 1.1 and all of our (positive) results is the discharging method.

The discharging method is a very common tool used for proving coloring results on sparse graphs. At heart, it is a counting argument that guarantees the existence of (easily) colorable structures in a given sparse graph. Such structures are commonly named *reducible configurations* as they cannot appear in a minimal counterexample to a desired theorem. A typical counting argument in the discharging method consists in translating the global sparseness of the graph into local weights, called *charges*. For instance, a charge can be the degree of a vertex or the size of a face (when the graph is planar). The goal then is to obtain, through a clever redistribution of these charges, a contradiction by showing that there exists a reducible configuration in a minimal counterexample. This redistribution is done via *discharging rules*. See the survey of Cranston and West [40] for more detailed explanations.

To illustrate the method, we will prove the following result.

**Theorem 1.20** ([82]). If  $G$  is a graph with  $\text{mad}(G) < \frac{8}{3}$ , then  $\chi_\ell^2(G) \leq \Delta(G) + 3$  for  $\Delta(G) \geq 4$ .

The first step is to assume by contradiction that there exists a counterexample to Theorem 1.20. More precisely, we consider a graph  $G$ , minimizing the number of vertices, with  $\text{mad}(G) < \frac{8}{3}$ ,  $\Delta(G) \geq 4$ , and  $\chi_\ell^2(G) \geq \Delta(G) + 4$ .

Using the fact that  $G$  is a minimal counterexample, we can deduce some structural properties of  $G$  and more precisely, some reducible configurations. Since we will always consider 2-distance list-colorings, we will omit “2-distance” for conciseness. For this section, as a drawing convention, next to each vertex, we will indicate a lower bound on the number of available colors given a certain precoloring from the context.

### Structural properties of $G$

**Lemma 1.21.** Graph  $G$  is connected.

*Chứng minh.* If  $G$  is not connected, then a component of  $G$  would be a smaller counterexample, which contradicts its minimality.  $\square$

We start by lower bounding the minimum degree of  $G$ .

**Lemma 1.22.**  $\delta(G) \geq 2$ .

*Chứng minh.* By Lemma 1.21,  $\delta(G) \geq 1$  or  $G$  would be a single isolated vertex which is  $(\Delta + 3)$ -list-colorable. If  $G$  contains a 1-vertex  $v$ , then we can simply remove such vertex and color the resulting graph, which is possible by minimality of  $G$ . Then, we add  $v$  back and color  $v$  (at most  $\Delta$  constraints and  $\Delta + 3$  available colors in its list).  $\square$

By Lemma 1.22,  $G$  cannot have vertices with too low degrees, we will also see (Lemmas 1.23 to 1.25) that  $G$  cannot have adjacent vertices with low degrees.

**Lemma 1.23.** Graph  $G$  has no  $2^+$ -threads.

*Chứng minh.* Suppose that  $G$  contains a 2-thread  $uvw$  (see Figure 1.4). We color  $G - \{v, w\}$  by minimality of  $G$ . Observe that  $v$  and  $w$  each sees at most  $\Delta + 1$  colors so they have at least two available colors left each. For example for  $v$ ,  $u$  and its colored neighborhood forbid at most  $\Delta(G)$  colors and  $x$  forbids one more; hence there remains two available colors for  $v$ . Thus, we can easily extend the coloring to  $v$  and  $w$ .  $\square$

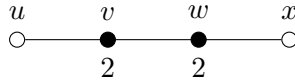

Hình 1.4: A  $2^+$ -thread.

In the same vein, we inspect sparse structures where a lot of vertices with low degree are close together.

**Lemma 1.24.** Graph  $G$  has no  $(1, 1, 1)$ -vertices.

*Chứng minh.* Suppose by contradiction that there exists a  $(1, 1, 1)$ -vertex  $u$  with three 2-neighbors  $u_1, u_2$ , and  $u_3$  (see Figure 1.5). We color  $G - \{u, u_1, u_2, u_3\}$  by minimality of  $G$ , then we extend this coloring to the remaining vertices by coloring  $u_1, u_2, u_3$ , and  $u$  in this order. Observe that this is possible since each  $u_i$  has 3 available colors and  $u$  has  $\Delta \geq 4$  available colors.  $\square$

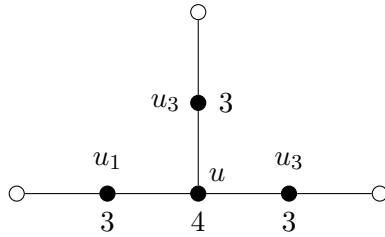

Hình 1.5: A  $(1, 1, 1)$ -vertex.

**Lemma 1.25.** Graph  $G$  has no  $(1, 0^+, 0)$ -vertices that are adjacent to a  $(1, 1, 0)$ -vertex.

*Chứng minh.* Suppose by contradiction that there exists a  $(1, 0^+, 0)$ -vertex  $u$  with a 2-neighbor  $v$  and a  $(1, 1, 0)$ -neighbor  $w$ . Let the 2-neighbors of  $w$  be  $w_1$  and  $w_2$  (see Figure 1.6).

First, observe that if two adjacent 3-vertices share a common 2-neighbor, for example, if  $u$  is also adjacent to  $w_1$ , then we color  $G - \{u, w, w_1\}$  by minimality of  $G$  and finish by coloring  $u, w$ , and  $w_1$  in this order. This is possible since we have  $\Delta + 3$  colors and  $\Delta \geq 4$ . Hence, all named vertices are distinct.

Now, we color  $G - \{u, v, w, w_1, w_2\}$  by minimality. Let  $L(x)$  be the list of available colors left for a vertex  $x \in \{u, v, w, w_1, w_2\}$ . Since we have  $\Delta + 3$  colors and  $\Delta \geq 4$ ,  $|L(v)| \geq 2$ ,  $|L(u)| \geq 2$ ,  $|L(w)| \geq 4$ ,  $|L(w_1)| \geq 3$ , and  $|L(w_2)| \geq 3$ . We remove the extra colors so that  $|L(x)|$  reaches the lower bound for each  $x \in \{u, v, w, w_1, w_2\}$ . Consider the two following cases.

- If  $L(u) \neq L(v)$ , then we color  $u$  with  $c \in L(u) \setminus L(v)$ . We finish by coloring  $w_1, w_2, w$ , and  $v$  in this order.

- If  $L(u) = L(v)$ , we color  $w_1$  with  $c \in L(w_1) \setminus L(u)$  (which is possible since  $|L(w_1)| = 3$  and  $|L(u)| = 2$ ). Then, we color  $w$  with  $d \in L(w) \setminus (L(u) \cup \{c\})$  (which is possible as  $|L(w)| = 4$ ). Finally, we finish by coloring  $w_2, u$ , and  $v$  in this order.

We thus obtain a valid coloring of  $G$ , which is a contradiction. □

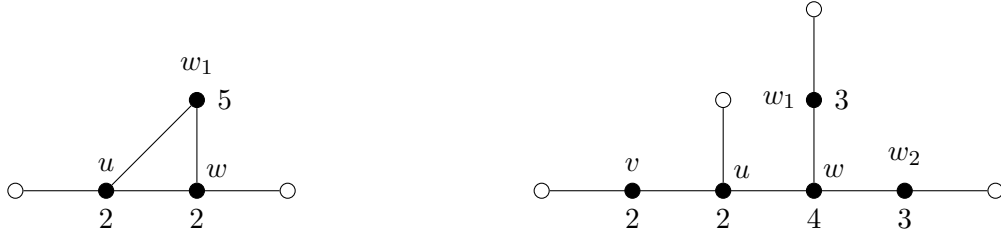

(i) Two 3-vertices sharing a 2-neighbor. (ii) A  $(1, 0^+, 0)$ -vertex  $u$  that is adjacent to a  $(1, 1, 0)$ -vertex  $w$ .

Hình 1.6: Reducible configurations from Lemma 1.25.

**Lemma 1.26.** Graph  $G$  has no 3-vertices with two  $(1, 1, 0)$ -neighbors and another 3-neighbor.

*Chứng minh.* Suppose by contradiction that there exists a 3-vertex  $u$  with two  $(1, 1, 0)$ -neighbors  $v$  and  $w$  and another 3-neighbor  $t$ . Let  $v_1$  and  $v_2$  (resp.  $w_1$  and  $w_2$ ) be  $v$ 's (resp.  $w$ 's) 2-neighbors (see Figure 1.7).

If  $v$  and  $w$  share a common 2-neighbor, say  $v_1 = w_1$ , then we color  $G - \{u, v, w, v_1, v_2, w_2\}$  by minimality of  $G$  and finish by coloring  $u, v, w, v_2, w_2$ , and  $v_1$  in this order. This is possible since we have  $\Delta + 3$  colors and  $\Delta \geq 4$ . Note that this coloring also works when  $v_2 = w_2$ . Hence, all named vertices are distinct.

Now, we color  $G - \{u, v, w, w_1, w_2\}$  by minimality. Let  $L(x)$  be the list of available colors left for a vertex  $x \in \{u, v, w, w_1, w_2\}$ . Since we have  $\Delta + 3$  colors and  $\Delta \geq 4$ ,  $|L(u)| \geq 2$  (as  $d(t) = 3$ ),  $|L(v)| \geq 2$ ,  $|L(w)| \geq 4$ ,  $|L(w_1)| \geq 3$ , and  $|L(w_2)| \geq 3$ . Note that we obtain the same lower bounds on the lists of colors as in Lemma 1.25. Thus, the exact same proof holds and we have a valid coloring of  $G$ , which is a contradiction. □

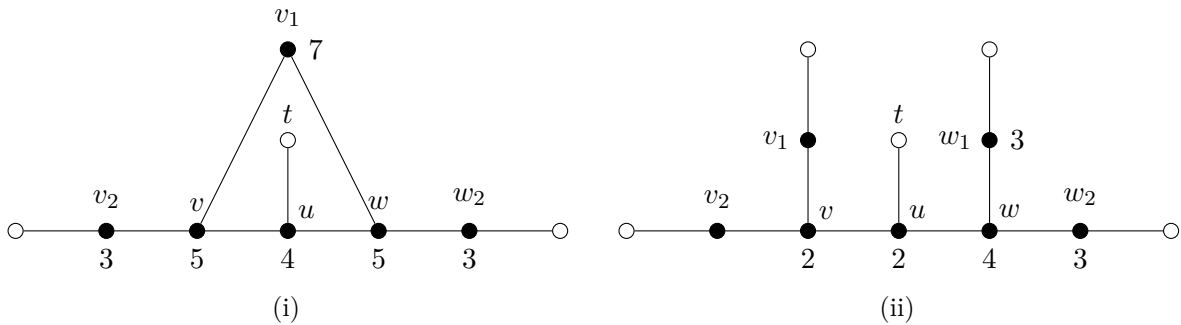

Hình 1.7: A 3-vertex  $u$  with two  $(1, 1, 0)$ -neighbors  $v, w$ , and another 3-neighbor  $t$ .

After studying the structural properties of  $G$ , we have eliminate sparse (colorable) structures from  $G$ . Now, we aim to prove that  $G$  is sparse enough to contain at least one of these structures, which is a contradiction. To do so, we will use a discharging procedure which is the main tool of the discharging method.

### Discharging rules

First, we translate  $G$ 's sparseness into local charges as follows. Since  $\text{mad}(G) < \frac{8}{3}$ , we have

$$\sum_{u \in V(G)} (3d(u) - 8) < 0 \quad (1.2)$$

We assign to each vertex  $u$  the charge  $\mu(u) = 3d(u) - 8$ . To prove the non-existence of  $G$ , we will redistribute the charges preserving their sum and obtaining a non-negative total charge, which will contradict Equation (1.2). This redistribution will be done via the following discharging rules:

**R0** Every  $3^+$ -vertex gives 1 to each of its 2-neighbors.

**R1** Every  $4^+$ -vertex gives 1 to each of its 3-neighbors.

**R2** Every  $(0, 0, 0)$ -vertex gives 1 to each of its  $(1, 1, 0)$ -neighbors.

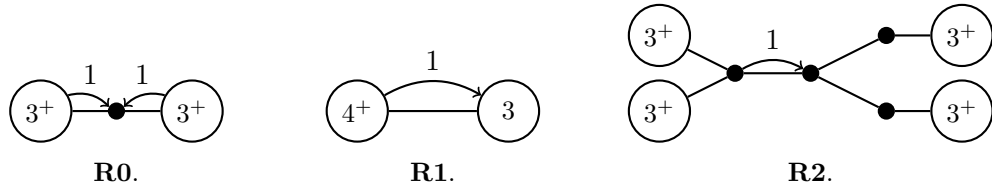

Hình 1.8: Discharging rules (the white vertices are labeled with their degree).

### Verifying that charges on each vertex are non-negative

Let  $\mu^*$  be the assigned charges after the discharging procedure. In what follows, we will prove that:

$$\forall u \in V(G), \mu^*(u) \geq 0.$$

Let  $u \in V(G)$ .

**Case 1:** If  $d(u) = 2$ , then  $u$  receives charge 1 from each endvertex of the 1-thread it lies on by **R0** (as there are no  $2^+$ -threads by Lemma 1.23). Thus, we get

$$\mu^*(u) = \mu(u) + 2 \cdot 1 = 3 \cdot 2 - 8 + 2 = 0.$$

**Case 2:** If  $d(u) = 3$ , then  $\mu(u) = 3 \cdot 3 - 8 = 1$ . Since there are no  $2^+$ -threads due to Lemma 1.23 and no  $(1, 1, 1)$ -vertices due to Lemma 1.24, we have the following cases.

- If  $u$  is a  $(1, 1, 0)$ -vertex, then  $u$  gives 1 to each of its two 2-neighbors by **R0**. At the same time,  $u$  also receives 1 from its  $3^+$ -neighbor  $v$  by **R1** or **R2** as  $v$  is either a  $4^+$ -vertex or a  $(0, 0, 0)$ -vertex by Lemma 1.25. To sum up,

$$\mu^*(u) \geq 1 - 2 \cdot 1 + 1 = 0.$$

- If  $u$  is a  $(1, 0, 0)$ -vertex, then  $u$  only gives 1 to its 2-neighbor by **R0**. Hence,

$$\mu^*(u) \geq 1 - 1 = 0.$$

- If  $u$  is a  $(0, 0, 0)$ -vertex, then  $u$  only gives charge to  $(1, 1, 0)$ -vertices by **R2**. Let  $t$ ,  $v$ , and  $w$  be  $u$ 's  $3^+$ -neighbors.

If  $u$  is adjacent to a  $4^+$ -neighbor, then it receives 1 by **R1** and at worst, it gives 1 to each of the two other neighbors by **R2**. As a result,

$$\mu^*(u) \geq 1 + 1 - 2 \cdot 1 = 0.$$

If  $u$  is adjacent to three 3-vertices, then at most one of them can be a  $(1, 1, 0)$ -vertex due to Lemma 1.26. So,  $u$  only gives at most 1 to a  $(1, 1, 0)$ -neighbor by **R2**. Consequently,

$$\mu^*(u) \geq 1 - 1 = 0.$$

**Case 3:** If  $4 \leq d(u) \leq \Delta$ , then, at worst,  $u$  gives 1 to each of its neighbors by **R0** and **R1**. As a result,

$$\mu^*(u) \geq 3d(u) - 8 - d(u) \geq 2 \cdot 4 - 8 = 0.$$

To conclude, we started with a charge assignment with a negative total sum, but after the discharging procedure, which preserved this sum, we end up with a non-negative one, which is a contradiction. In other words, there exists no counter-examples to Theorem 1.20.

## Chương 2

# The potential method

In this chapter, we discuss one of the limits of the discharging method and how we push this limit further with the potential method.

The idea with the discharging method is to show that a graph with bounded mad is sparse enough to contain a colorable structure. In practice, we try to color sparse structures to prove that they are reducible configurations. For dense structures, the vertices in the graph naturally contain more charges as our charge assignment often increases with their degree. This allows a redistribution of charges in order to obtain a non-negative final sum more easily. Hence, the limit of this method comes from structures that are not sparse enough to be reducible but also not dense enough to have sufficient charge. In this context, the *potential method* helps reducing denser structures.

Reducing a configuration (with set of vertices)  $S$ , in a minimal counter-example  $G$ , often implies the extension a precoloring of  $G - S$ . Until now, we have always assumed the worst case scenario for the precoloring of  $G - S$ . In order to avoid the worst case scenario, we need to add some vertices and edges, say a set  $T$ , to  $G - S$  but we might run into the risk of increasing our maximum average degree, i.e.  $G - S + T$  is not in the same class of bounded mad. The potential method introduces a potential function that quantifies precisely the maximum average degree of  $G - S$  and  $G - S + T$ . This helps with introducing constraint on the precoloring to avoid the worst case scenario while staying in the same class of graphs.

With the help of the potential method, we will prove the following theorem.

**Theorem 2.1** ([85]). If  $G$  is a graph with  $\text{mad}(G) < \frac{18}{7}$ , then  $G$  is 2-distance  $(\Delta(G) + 1)$ -colorable for  $\Delta(G) \geq 7$ .

Since Bonamy *et al.* has already proven in [7] that:

**Theorem 2.2** (Bonamy *et al.* [7]). If  $G$  is a graph with  $\text{mad}(G) < \frac{18}{7}$ , then  $G$  is list 2-distance  $(\Delta(G) + 1)$ -colorable for  $\Delta(G) \geq 8$ .

We will prove the following, which is a stronger version with  $\text{mad}(G) \leq \frac{18}{7}$  instead of  $\text{mad}(G) < \frac{18}{7}$ :

**Theorem 2.3.** If  $G$  is a graph with  $\text{mad}(G) \leq \frac{18}{7}$ , then  $G$  is 2-distance  $(\Delta(G) + 1)$ -colorable for  $\Delta(G) = 7$ .

To prove Theorem 2.3, let us define the potential function, which is the key to the potential method.

**Definition 2.4.** Let  $A \subseteq V(G)$ , we define  $\rho_G(A) = 9|A| - 7|E(G[A])|$ .

**Definition 2.5.** We define the *potential function*  $\rho_G^*(A) = \min\{\rho_G(S) | A \subseteq S \subseteq V(G)\}$  for all  $A \subseteq V(G)$ .

Note that  $\rho_G^*(A) \geq 0$  for all  $A \subseteq V(G)$  if and only if  $\text{mad}(G) \leq \frac{18}{7}$ . Thus, we will prove the following equivalent version of Theorem 2.3.

**Theorem 2.6.** Let  $G$  be a graph such that  $\rho_G^*(A) \geq 0$  for all  $A \subseteq V(G)$ , then  $G$  is 2-distance  $(\Delta(G) + 1)$ -colorable for  $\Delta(G) = 7$ .

First, let us start by studying some elementary operations with the potential function.

## 2.1 Elementary operations with the potential function

In this section, we will prove some useful inequalities, that will be used repeatedly in our proof, involving this potential function on a graph  $G$  with  $\text{mad}(G) \leq \frac{18}{7}$ .

We start with some simple observations that come as a consequence of the definition of the potential function.

Let  $A, S \subseteq V(G)$  such that  $A \subseteq S$ . Since any  $K \subseteq V(G)$  that contains  $S$  will also contain  $A$ , by definition of  $\rho_G^*$ , we have:

$$\rho_G^*(S) \geq \rho_G^*(A). \quad (2.1)$$

Let  $A \subseteq V(G)$  and  $H$  be a subgraph of  $G$  that contains  $A$ . Since any subset  $S \subseteq V(H)$  that contains  $A$  is also a subset of  $V(G)$ , by definition of  $\rho_G^*$ , the following ensues:

$$\rho_H^*(A) \geq \rho_G^*(A). \quad (2.2)$$

Let  $A, B \subseteq V(G)$ . Since  $|A| + |B| = |A \cup B| + |A \cap B|$  and  $|E(G[A])| + |E(G[B])| \leq |E(G[A \cup B])| + |E(G[A \cap B])|$ , we have  $\rho_G(A) + \rho_G(B) \geq \rho_G(A \cup B) + \rho_G(A \cap B)$ .

Now, let  $A \subseteq S \subseteq V(G)$  and  $B \subseteq T \subseteq V(G)$  such that  $\rho_G(S) = \rho_G^*(A)$  and  $\rho_G(T) = \rho_G^*(B)$ . By the previous observation, we have  $\rho_G^*(A) + \rho_G^*(B) = \rho_G(S) + \rho_G(T) \geq \rho_G(S \cup T) + \rho_G(S \cap T)$ . Since  $(A \cup B) \subseteq (S \cup T)$  and  $(A \cap B) \subseteq (S \cap T)$ , by definition of  $\rho_G^*$ , we have the following:

$$\rho_G^*(A) + \rho_G^*(B) \geq \rho_G^*(A \cup B) + \rho_G^*(A \cap B). \quad (2.3)$$

Now, we come to the most important property of the potential function. Let  $A$  and  $S$  be disjoint subsets of  $V(G)$  such that  $S$  contains (at least) every vertex (not in  $A$ ) that is adjacent to a vertex in  $A$ . We denote  $E(A, S)$  the set of edges between vertices of  $A$  and  $S$  (see Figure 2.1).

By definition,  $\rho_G(A \cup S) = 9|A \cup S| - 7|E(G[A \cup S])| = 9(|A| + |S|) - 7(|E(G[A])| + |E(G[S])| + |E(A, S)|) = (9|S| - 7|E(G[S])|) + (9|A| - 7|E(G[A])|) - 7|E(A, S)| = \rho_G(S) + \rho_G(A) - 7|E(A, S)|$ . Since  $\text{mad}(G) \leq \frac{18}{7}$ , we know that  $\rho_G(A \cup S) \geq 0$ . Thus,  $\rho_G(S) \geq 7|E(A, S)| - \rho_G(A)$ . Observe that  $S \subseteq V(G - A)$  and the previous inequality holds for any  $K \subseteq V(G - A)$  that contains  $S$ . Moreover for every  $K$  that contains  $S$  we have  $|E(A, S)| = |E(A, K)|$  by definition of  $S$ . Hence, the following also holds:

$$\rho_{G-A}^*(S) \geq 7|E(A, S)| - \rho_G(A). \quad (2.4)$$

In practice, when we remove a certain structure  $A$  from a minimal counterexample  $G$ . We try to color  $G - A$  then extend this coloring to  $G$  to prove that  $A$  is a reducible configuration. However, sometimes, there exists a worst case scenario where the coloring of  $G - A$  is not extendable to  $G$ . Equation (2.4) quantifies the increase of potential (which is the interesting case) of  $N_G(A)$  when we remove  $A$ . In other words, we know how much ‘‘sparser’’ the ‘‘surrounding’’ of  $A$  gets when we remove  $A$ . This allows us to replace  $A$  with another ‘‘good’’ structure, say  $A'$  (see Figure 2.1), that can decrease that potential while staying non-negative which means that we stay in the same class of  $\text{mad}$ . In terms of coloring, it means that  $H = G - A + A'$  has  $\text{mad} \leq \frac{18}{7}$ , is smaller than  $G$ , and is thus colorable. Moreover, the presence of  $A'$  imposes some constraints on the coloring of  $N_G(A)$  which might allow us to avoid the worst case scenario and to extend the coloring to  $G$ .

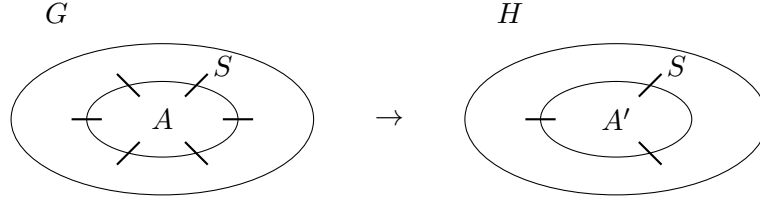

Hình 2.1: Replacing a configuration  $A$  with a “good” structure  $A'$ .

The following lemmas show how we can add threads between two vertices depending on their (positive) potential.

**Lemma 2.7.** Suppose graph  $H$  verifies  $\text{mad}(H) \leq \frac{18}{7}$ . Let  $k \geq 0$  and  $u, v \in V(H)$ . Moreover assume that  $\rho_H^*(\{u, v\}) \geq 7 - 2k$ . Let  $H' = H + P$  be the graph obtained from  $H$  in which we add a  $k$ -thread  $P$  between  $u$  and  $v$  ( $P$  is just an edge when  $k = 0$ ), then  $\text{mad}(H') \leq \frac{18}{7}$  (equivalently,  $\forall T \subseteq V(H'), \rho_{H'}(T) \geq 0$ ).

*Chứng minh.* Indeed, every subset  $S \subseteq V(H')$  that does not contain any vertex or edges of  $P$  is a subset of  $V(H)$  so  $\rho_{H'}(S) = \rho_H(S) \geq 0$ . Now, consider a vertex set  $T$ , intersecting with  $P$ , with the minimum potential. Observe that vertices in  $T$  have degree, in  $H'[T]$ , at least 2. Otherwise, it suffices to remove a vertex of degree 0 or 1 from  $T$  and we obtain a set with lower potential (which contradicts the minimality of  $\rho(T)$ ) as removing an isolated vertex decreases the potential by 9 and removing a vertex of degree 1 decreases the potential by  $9 - 7 = 2$ . Consequently,  $T$  must contain the whole thread  $P$  as well as  $u, v$ . Observe that  $T - P$  is a subset of  $V(H)$  that contains  $u, v$  and  $\rho_{H'}(T) = \rho_H(T - P) + 9k - 7(k + 1) = \rho_H(T - P) + 2k - 7 \geq \rho_H^*(\{u, v\}) + 2k - 7 \geq 7 - 2k + 2k - 7 = 0$ .  $\square$

**Observation 2.8.** Let  $0 \leq k \leq 3$ , observe that in the proof of Lemma 2.7, adding a  $k$ -thread  $P$  between  $u$  and  $v$  in  $H$  decreases the potential of every set containing  $\{u, v\}$  by at most  $7 - 2k$  in  $H + P$ . In other words, for every  $S \subseteq V(H + P)$  such that  $\{u, v\} \subseteq S$ ,  $\rho_{H + P}^*(S) \geq \rho_H^*(S - P) - (7 - 2k)$  ( $S - P$  still contains  $\{u, v\}$ ).

**Lemma 2.9.** Let  $H$  be a graph,  $u, v \in V(H)$  and  $0 \leq k \leq 3$ . Let  $H' = H + P$  be the graph obtained from  $H$  in which we add a  $k$ -thread  $P$  between  $u$  and  $v$  ( $P$  is just an edge when  $k = 0$ ), then for every  $A \subseteq V(H)$ ,  $\rho_H^*(A) = \rho_{H'}^*(A)$  or  $\rho_{H'}^*(A) \leq \rho_H^*(A) \leq \rho_H^*(A \cup \{u, v\}) \leq \rho_{H'}^*(A) + (7 - 2k)$ .

*Chứng minh.* First, by Equation (2.2),  $\rho_H^*(A) \geq \rho_{H + P}^*(A)$ . Let us consider  $S \subseteq V(H + P)$  such that  $A \subseteq S$  and  $\rho_{H + P}(S) = \rho_{H + P}^*(A)$ . Note that  $\rho_{H + P}(S) = \rho_{H + P}^*(S)$  since  $\rho_{H + P}(S) \geq \rho_{H + P}^*(S)$  by definition of  $\rho^*$ , and  $\rho_{H + P}(S) \leq \rho_{H + P}^*(S)$  or else, it means there exists  $T$  such that  $A \subseteq S \subset T$  and  $\rho_{H + P}(T) < \rho_{H + P}(S) = \rho_{H + P}^*(A)$  which is a contradiction.

If  $\{u, v\} \not\subseteq S$ , then  $S \subseteq V(H)$  as  $S$  cannot intersect  $P$  by minimality of  $\rho_{H + P}(S)$  (or else it would contain a vertex, of degree 0 or 1 in  $H'[S]$ , whose removal would decrease the potential). Thus,  $\rho_H(S) = \rho_{H + P}(S)$ . As a result,  $\rho_H^*(A) \leq \rho_H(S) = \rho_{H + P}(S) = \rho_{H + P}^*(A)$ .

If  $\{u, v\} \subseteq S$ , then  $S$  contains  $P$  by minimality of  $\rho_{H + P}(S)$  (or else by adding  $P$  to  $S$ , we would decrease the potential by  $7(k + 1) - 9k = 7 - 2k \geq 1$ ). By Observation 2.8,  $\rho_H^*(S - P) - (7 - 2k) \leq \rho_{H + P}^*(S)$ . So, by Equation (2.1),  $\rho_H^*(A) \leq \rho_H^*(A \cup \{u, v\}) \leq \rho_H^*(S - P) \leq \rho_{H + P}^*(S) + (7 - 2k) = \rho_{H + P}(S) + (7 - 2k) = \rho_{H + P}^*(A) + (7 - 2k)$ .  $\square$

From now on, we will write  $\rho_G^*(v_0 v_1 \dots v_i)$  instead of  $\rho_G^*(\{v_0, v_1, \dots, v_i\})$  for conciseness. Also, for a graph  $H$ , we will say  $\text{mad}(H) \leq \frac{18}{7}$  instead of “for all  $S \subseteq V(H)$ ,  $\rho_H^*(S) \geq 0$ ” which is equivalent.



## 2.2 Structural properties of a minimal counterexample

Since the whole chapter will be about 2-distance coloring, from now on, when we say “to color” a vertex, it means to color such vertex differently from all of its colored neighbors at distance at most two. Similarly, any considered coloring will be a 2-distance coloring. As a drawing convention, dashed edges and vertices represent threads that we might add after removing some structure from the graph in the context. We will also label some white vertices with information about its degree.

Let  $G$  be a counterexample to Theorem 2.6 with the fewest number of vertices plus edges. In other words,  $G$  has  $\Delta(G) = 7$ ,  $\text{mad}(G) \leq \frac{18}{7}$ , and  $\chi^2(G) \geq \Delta(G) + 2 = 9$ . Once again, we start by studying the structural properties of  $G$  to find reducible configurations.

We start by lower bounding the minimum degree in  $G$ .

**Lemma 2.10.** Graph  $G$  is connected.

*Chứng minh.* Otherwise a connected component of  $G$  would be a smaller counterexample.  $\square$

**Lemma 2.11.**  $\delta(G) \geq 2$ .

*Chứng minh.* By Lemma 2.10,  $\delta(G) \geq 1$ . If  $G$  contains a 1-vertex  $v$ , then we can simply remove the unique edge incident to  $v$  and color the resulting graph, which is possible by minimality of  $G$ . Then, we add the edge back and recolor  $v$  (at most 7 constraints and 8 colors).  $\square$

Here, we show that a vertex cannot have too many neighbors with a small 2-distance neighborhood or it would be reducible.

**Lemma 2.12.** Let  $w$  be a vertex of  $V$  that is adjacent to  $k$  vertices  $u_i$  ( $k \leq d(w)$ ), each satisfying  $d_G^*(u_i) \leq \Delta + i - 1$  for  $1 \leq i \leq k$ . Then we have  $d_G^*(w) \geq \Delta + k + 1$ .

*Chứng minh.* Suppose by contradiction that  $w$  is adjacent to  $u_i$  with  $d_G^*(u_i) \leq \Delta + i - 1$  for  $1 \leq i \leq k$ , but  $d_G^*(w) \leq \Delta + k$  (see Figure 2.2). We remove the edges  $wu_i$  for  $1 \leq i \leq k$ . By minimality of  $G$ , let  $\phi_H$  be a coloring of  $H = (V, E \setminus \{wu_1, \dots, wu_k\})$ .

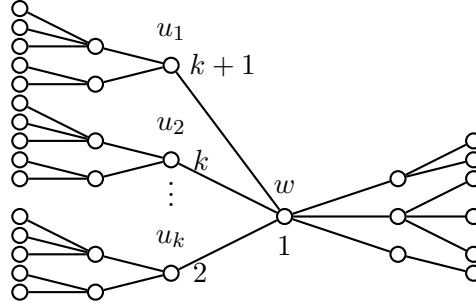

Hình 2.2: Next to each vertex is the number of available colors left when  $G - \{w, u_1, u_2, \dots, u_k\}$  is already colored.

We extend  $\phi$  to  $G$  as follows :

1. We define  $\phi_G(v) = \phi_H(v)$  for all  $v \in V \setminus \{w, u_1, \dots, u_k\}$ .
2. We choose  $\phi_G(w)$  a color that does not appear in  $F_w = N_G^*(w) \setminus \{u_1, \dots, u_k\}$ . We have  $|F_w| = d_G^*(w) - k$ . By hypothesis, we have  $d_G^*(w) \leq \Delta + k$  and thus  $|F_w| \leq \Delta$ . Thus, we can color  $w$  since we have  $\Delta + 1$  colors.
3. One by one, from  $k$  to 1, we choose  $\phi_G(u_i)$  a color that does not appear in  $F_{u_i} = N_G^*(u_i) \setminus \{u_1, \dots, u_{i-1}\}$ . Since  $d_G^*(u_i) \leq \Delta + i - 1$ , we have  $|F_{u_i}| = d_G^*(u_i) - (i - 1) \leq (\Delta + i - 1) - (i - 1) = \Delta$ . So, there remains at least one color for  $u_i$ .

Hence the obtained coloring  $\phi_G$  is a 2-distance coloring of  $G$ , which is a contradiction.  $\square$

**Observation 2.13.** Let  $w$  be a vertex of  $V$  that is adjacent to  $k$  vertices  $u_i$ , each satisfying  $d^*(u_i) \leq 7 = \Delta$  ( $\leq \Delta + i - 1$ ) for  $1 \leq i \leq k$ . Then we have  $d^*(w) \geq \Delta + k + 1 = 8 + k$  due to Lemma 2.12.

Using Observation 2.13, we can deduce some properties of sparse structures like threads in  $G$ .

**Lemma 2.14.** Graph  $G$  has no  $4^+$ -threads.

*Chứng minh.* Suppose  $G$  contains a 4-thread  $v_0v_1 \dots v_5$  (see Figure 2.3). Then,  $d^*(v_2) = d^*(v_3) = 4 \leq \Delta$  which contradicts Observation 2.13.  $\square$

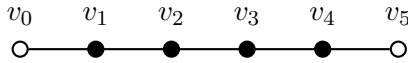

Hình 2.3: A 4-thread.

**Lemma 2.15.** A 3-thread has two distinct endvertices and both have degree  $\Delta$ .

*Chứng minh.* Suppose that  $G$  contains a 3-thread  $v_0v_1 \dots v_4$  (see Figure 2.4).

If  $v_0 = v_4$ , then we color  $H = G - \{v_1, v_2, v_3\}$  by minimality of  $G$  and extend the coloring to  $G$  by coloring greedily  $v_1$  and  $v_3$  who has two available colors each and finish with  $v_2$  who only sees three colors.

Now, suppose that  $v_0 \neq v_4$ , since  $d^*(v_2) = 4 \leq \Delta$ , we have  $d^*(v_3) \geq \Delta + 2$  due to Observation 2.13. Moreover,  $d^*(v_3) = d(v_4) + 2$ , so  $d(v_4) \geq \Delta$ . The same holds for  $v_0$  by symmetry.  $\square$

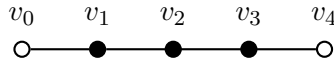

Hình 2.4: A 3-thread.

**Lemma 2.16.** At least one of the endvertices of a 2-thread has degree  $\Delta$  or both of them have degree  $\Delta - 1$ . The endvertices of a 2-thread are also distinct.

*Chứng minh.* Consider a 2-thread  $v_0v_1v_2v_3$  (see Figure 2.5) where  $d(v_0) \leq d(v_3)$ .

If  $v_0 = v_3$ , then we color  $H = G - \{v_1, v_2\}$  by minimality of  $G$  and extend the coloring to  $G$  by coloring greedily  $v_1$  and  $v_2$  who has two available colors each.

Now, suppose that  $v_0 \neq v_3$ . Suppose by contradiction that  $d(v_3) \leq \Delta - 1$  and  $d(v_0) \leq \Delta - 2$ . Since  $d(v_0) \leq \Delta - 2$ ,  $d^*(v_1) = d(v_0) + 2 \leq \Delta$ . So, by Observation 2.13,  $d^*(v_2) = d(v_3) + 2 \geq \Delta + 2$  meaning that  $d(v_3) \geq \Delta$ , which is a contradiction.  $\square$

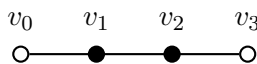

Hình 2.5: A 2-thread.

**Lemma 2.17.** Let  $uvwx$  be a 2-thread. If  $d(u) = 7$  and  $d(x) \leq 6$ , then  $u$  cannot be adjacent to  $x$ .

*Chứng minh.* Suppose by contradiction that  $u$  is adjacent to  $x$ . Let  $H = G - \{v, w\}$ . By minimality of  $G$ , we color  $H$ , then we finish by coloring  $v$  then  $w$  in this order.  $\square$

**Lemma 2.18.** Let  $v \in V$  such that  $3 \leq d(v) \leq \lfloor \frac{\Delta+1}{2} \rfloor$ . Then  $v$  cannot be a  $(2, 1^+, 1^+, \dots, 1^+)$ -vertex.

*Chứng minh.* Suppose that  $G$  contains a vertex  $v$  with  $3 \leq d(v) \leq \lfloor \frac{\Delta+1}{2} \rfloor$  that is a  $(2, 1^+, 1^+, \dots, 1^+)$ -vertex. Let  $w$  be a neighbor of  $v$  that belongs to a 2-thread (see Figure 2.6). We have  $d^*(w) = d(v) + 2$  and  $d^*(v) = 2d(v)$ . Moreover, as  $d(v) \leq \lfloor \frac{\Delta+1}{2} \rfloor$ , it follows that  $d^*(w) \leq \Delta$  since  $\Delta > 3$ . Thus,  $d^*(v) \geq \Delta + 2$  by Observation 2.13. Since  $d(v)$  is an integer and  $2d(v) \geq \Delta + 2$ ,  $d(v) \geq \lceil \frac{\Delta+2}{2} \rceil$  which contradicts  $d(v) \leq \lfloor \frac{\Delta+1}{2} \rfloor$ .  $\square$

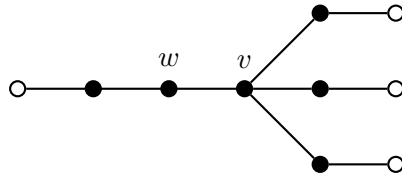

Hình 2.6: A  $(2, 1^+, \dots, 1^+)$ -vertex  $v$  with  $3 \leq d(v) \leq \lfloor \frac{\Delta+1}{2} \rfloor$ .

Now, we reduce some sparse structures surrounding high degree vertices.

**Lemma 2.19.** Let  $u$  be a 7-vertex that is incident to six 2-threads where the other endvertices are  $5^-$ -vertices. Then,  $u$  cannot be incident to a 3-thread, a  $(2, 2, 0)$ -vertex or another 2-thread where the other endvertex is a  $6^-$ -vertex.

*Chứng minh.* Suppose by contradiction that  $u$  is incident to six 2-threads where the other endvertices are  $5^-$ -vertices and that  $u$  is also incident to a 3-thread, or a  $(2, 2, 0)$ -vertex, or another 2-thread where the other endvertex is a  $6^-$ -vertex (see Figure 2.7).

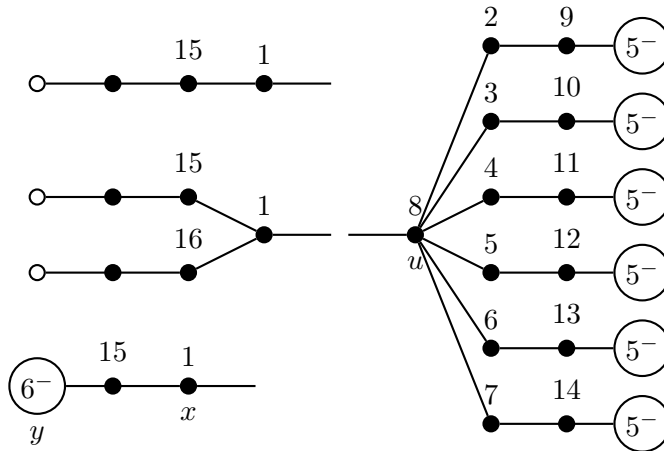

Hình 2.7: The order in which the coloring will be extended to  $G$  is indicated above the vertices.

First, observe that  $u$  is distinct from the other endvertex of its incident 3-thread due to Lemma 2.15 and from the endvertices of the 2-threads incident to its  $(2, 2, 0)$ -neighbor due to Lemma 2.17.

Consider  $H = G - (\{u\} \cup N_G^*(u))$ . By minimality of  $G$ , there exists a coloring of  $H$  that we will extend to  $G$  by coloring the vertices in the order indicated in Figure 2.7 with the specification that in the case where  $u$  is incident to another 2-thread with a  $6^-$ -endvertex  $y$ ,  $u$ 's 2-neighbor  $x$

on this thread will be colored with the same color as a colored neighbor of  $y$ . The indicated order verifies at each step that the considered vertex sees at most seven colors. Thus, we obtain a valid coloring of  $G$  which is a contradiction.  $\square$

Observe that until the proof of Lemma 2.19, all lemmas hold for a list version of the coloring. However, when we repeat a color on  $x$  that appears on some other colored vertex, we need a non-list version of the coloring. The same type of arguments will be used in future lemmas, thus the result is restricted to non-list 2-distance coloring.

**Lemma 2.20.** A 6-vertex cannot be incident to six 2-threads where the other endvertices are 6-vertices.

*Chứng minh.* Consider  $H$  the graph  $G$  where we removed the 6-vertex  $u$  and all 2-vertices on the 2-threads incident to  $u$ . Consider the internal 2-vertices  $p_1$  and  $p_2$  on a 2-thread incident to  $u$  (see Figure 2.8). We color the 2-vertex  $p_2$  at distance 2 from  $u$ , which has at least two available colors, and a 2-neighbor  $x$  of  $u$  (at distance 3 from  $p_2$ ), which has seven available colors, with the same color by the pigeonhole principle (as we have 8 colors in total). Now, we color all other 2-vertices at distance 2 from  $u$ , then  $u$ . Finally, we color all vertices of  $N_G(u)$  by finishing with  $p_1$  which now sees eight colored vertices but two of them share the same color.  $\square$

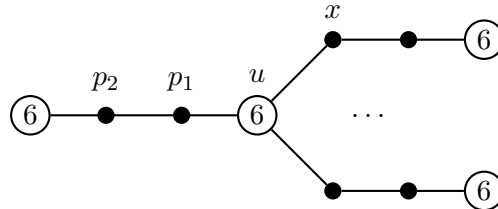

Hình 2.8: A 6-vertex  $u$  incident to six 2-threads with 6-endvertices.

Now, we take a look at a sparse structure that is right at the limit of not being sparse enough to be reducible directly but not dense enough to have enough charges for our future discharging procedure. The configuration at issue is 3-threads. We start by showing that 3-threads in  $G$  form a forest-like structure.

**Lemma 2.21.** Graph  $G$  has no cycles consisting of 3-threads.

*Chứng minh.* Suppose that  $G$  contains a cycle consisting of  $k$  3-threads (see Figure 2.9). We remove all vertices  $v_{4i+1}, v_{4i+2}, v_{4i+3}$  for  $0 \leq i \leq k - 1$ . Consider a coloring of the resulting graph. We color  $v_1, v_3, v_5, \dots, v_{4k-1}$ , which is possible since each of them has at least two choices of colors (as  $d(v_0) = d(v_4) = \dots = d(v_{4(k-1)}) = \Delta$  due to Lemma 2.15) and by 2-choosability of even cycles. Finally, it is easy to color greedily  $v_2, v_6, \dots, v_{4k-2}$  since they each have at most four forbidden colors.  $\square$

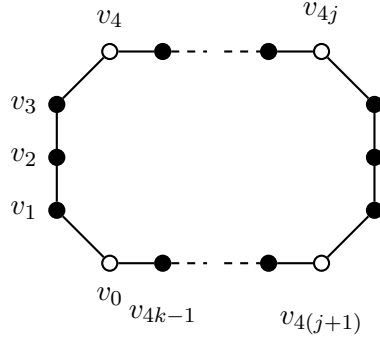

Hình 2.9: A cycle consisting of consecutive 3-threads.

Without the use of the potential function, results that came before ours had to deal with arbitrarily large forests of 3-threads. However, we show that the size of these structures are relatively “small” with the following three lemmas.

**Lemma 2.22.** Let  $1 \leq k \leq 3$  and  $up_1 \dots p_kv$  be a  $k$ -thread in  $G$  and let  $P = \{p_1, \dots, p_k\}$ . If  $\rho_{G-P}^*(u) \leq \rho_{G-P}^*(v)$ , then  $\rho_{G-P}^*(v) \geq 1$ .

*Chứng minh.* Suppose by contradiction that  $\rho_{G-P}^*(v) = \rho_{G-P}^*(u) = 0$  (recall that  $\rho_{G-P}^*(u) \geq 0$  since  $\text{mad}(G) \leq \frac{18}{7}$ ). Then, by Equation (2.3),  $0 = \rho_{G-P}^*(v) + \rho_{G-P}^*(u) \geq \rho_{G-P}^*(uv)$ . However, by Equation (2.4),  $\rho_{G-P}^*(uv) \geq 7|E(P, \{u, v\})| - \rho_G(P) \geq 7 \cdot 2 - (9 \cdot 3 - 7 \cdot 2) = 1$ , which is a contradiction.  $\square$

**Lemma 2.23.** Let  $up_1p_2p_3v$  and  $vp'_1p'_2p'_3w$  be two consecutive 3-threads in  $G$  and let  $P = \{p_1, p_2, p_3\}$  and  $P' = \{p'_1, p'_2, p'_3\}$ . Then  $\rho_{G-P}^*(u) = \rho_{G-P'}^*(w) = 0$ .

*Chứng minh.* Note that by Lemma 2.15 and Lemma 2.21,  $u, v$ , and  $w$  are pairwise distinct and  $d(u) = d(v) = d(w) = \Delta = 7$ . Let  $H = G - (P \cup P')$ . We add the 3-thread  $up'_1p'_2p'_3w$  in  $H$  and let  $P'' = \{p''_1, p''_2, p''_3\}$  and let  $H + P''$  be the resulting graph (see Figure 2.10).

Suppose that  $\rho_H^*(uw) \geq 1$ . Then, by Lemma 2.7 with  $k = 3$ ,  $\text{mad}(H + P'') \leq \frac{18}{7}$ . Observe that  $|V(H + P'')| + |E(H + P'')| < |V(G)| + |E(G)|$ , so  $H + P''$  is colorable with a coloring  $\psi$  by minimality of  $G$ . We define  $\phi$  a coloring of  $G$  as follows:

- If  $x \in V(H)$ , then  $\phi(x) = \psi(x)$ .
- Let  $\phi(p_1) = \psi(p''_1)$  and  $\phi(p'_3) = \psi(p''_3)$ .
- Observe that  $p_3$  and  $p'_1$  can be colored. Otherwise, they have to see the same seven colors at distance at most 2. Since they see the same 6 colored vertices in  $v \cup N_G(v) \setminus \{p_3, p'_1\}$  (as  $d(v) = \Delta = 7$  by Lemma 2.15),  $\phi(p_1)$  must be the same as  $\phi(p'_3)$ , which is impossible because  $\phi(p_1) = \psi(p''_1) \neq \psi(p''_3) = \phi(p'_3)$ .
- Finally,  $p_2$  and  $p'_2$  can be colored greedily since they see at most 4 different colors at distance 2 each.

As  $\psi$  is a valid coloring of  $H + P''$ ,  $\phi$  is a valid coloring of  $G$ , which is a contradiction.

Suppose that  $\rho_H^*(uw) = 0$  (recall that  $\rho_H^*(uw) \geq 0$  since  $H$  is a subgraph of  $G$ ). By Equation (2.1),  $\rho_H^*(uw) \geq \rho_H^*(u)$  and by Equation (2.2),  $\rho_H^*(u) = \rho_{G-(P \cup P')}^*(u) \geq \rho_{G-P}^*(u)$ . Hence,  $0 \leq \rho_{G-P}^*(u) \leq \rho_H^*(uw) = 0$ . Symmetrically, the same holds for  $\rho_{G-P'}^*(w)$ .  $\square$

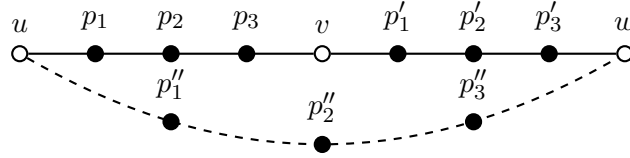

Hình 2.10: Two consecutive 3-threads.

**Lemma 2.24.** Graph  $G$  has no three consecutive 3-threads.

*Chứng minh.* Suppose by contradiction that  $G$  has three consecutive 3-threads  $up_1p_2p_3v$ ,  $vp'_1p'_2p'_3w$ , and  $wp''_1p''_2p''_3x$ . Let  $P' = \{p'_1, p'_2, p'_3\}$ . By applying Lemma 2.23 to  $up_1p_2p_3v$  and  $vp'_1p'_2p'_3w$ , we get  $\rho_{G-P'}^*(w) = 0$ . By applying Lemma 2.23 to  $vp'_1p'_2p'_3w$  and  $wp''_1p''_2p''_3x$ , we get  $\rho_{G-P'}^*(v) = 0$ . This is impossible due to Lemma 2.22.  $\square$

Due to Lemma 2.24, the 3-threads in  $G$  have a “star-like” structure. Moreover, with Lemma 2.23, we know that the extremities of these stars must be dense. Thus, we can avoid some sparse configurations in their surroundings.

Before moving on, we make an useful coloring observation that comes as a consequence of Hall’s Theorem.

**Theorem 2.25** (Hall [65]). A bipartite graph with partition sets  $A$  and  $B$  admits a matching (set of non incident edges) that covers every vertex of  $A$  if and only if for every set  $S \subseteq A$ ,  $|N(S)| \geq |S|$ .

**Observation 2.26.** Let  $u_1, u_2, \dots, u_k$  be  $k$  vertices that are pairwise at distance at most two and let  $L_i$  be the list of available colors of  $u_i$  for  $1 \leq i \leq k$ . Consider the bipartite graph  $H$  where  $V(H) = \{u_1, \dots, u_k\} \cup \{1, 2, \dots, 8\}$  and  $E(H) = \{(u_i, k) | k \in L_i\}$  (see Figure 2.11 for an example). By Hall’s Theorem, if for all  $1 \leq l \leq k$ , for all  $i_1, i_2, \dots, i_l$ ,  $|\cup_{j=1}^l L_{i_j}| \geq l$ , then  $u_1, u_2, \dots, u_k$  are colorable, each with a color from its list.

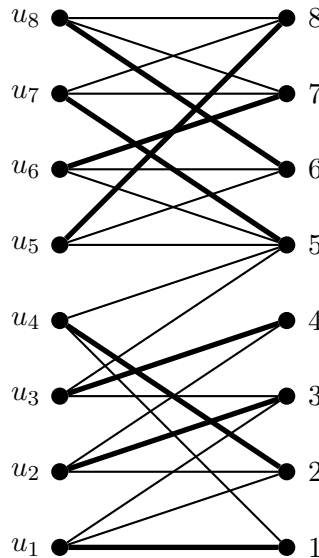

Hình 2.11: The thick edges form a matching that gives a valid coloring of  $\{u_1, \dots, u_8\}$ .

In other words, if there are more available colors for any subset of vertices than the size of that subset, then we can color every vertex with a different color. Such a coloring is, in particular, a 2-distance coloring.

**Lemma 2.27.** Let  $u$  be a 7-vertex and  $up_1p_2v$  be a 2-thread incident to  $u$  and let  $P = \{p_1, p_2\}$ . If  $\rho_{G-P}^*(u) \leq \rho_{G-P}^*(v)$ , then  $u$  cannot be incident to six other 2-threads where the other endvertices are  $5^-$ -vertices.

*Chứng minh.* Suppose by contradiction that  $u$  is incident to seven 2-threads, say  $uq_iq'_iv_i$  for  $1 \leq i \leq 6$  and  $up_1p_2v$ . Note that by Lemma 2.16,  $u$  is distinct from  $v$ . Let  $H = G - (\{q_i, q'_i | 1 \leq i \leq 6\} \cup \{p_1, p_2, u\})$ .

Consider  $A = \{q_i, q'_i | 1 \leq i \leq 6\} \cup \{p_1, p_2, u\}$  and  $S = \{v, v_1, v_2, \dots, v_6\}$ . Using Equation (2.4), we can lower bound the potential of  $S$  when we remove  $A$ . This potential is high enough (equivalently,  $S$  is “sparse enough” in  $G - A$ ) that when we add a 2-thread  $P$  between vertices of  $S$ , we still stay in the same class of bounded mad and we can use a coloring of  $G - A + P$  (which is smaller than  $G$ ) to define a coloring for  $G$  (avoiding the worst case scenario given by a coloring of  $G - A$ ). See Figure 2.12.

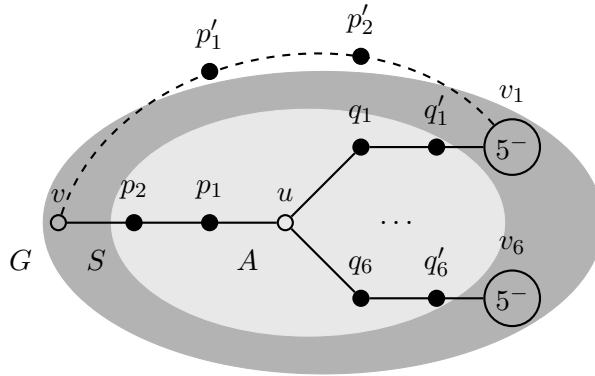

Hình 2.12: A 7-vertex incident to 2-threads, six of which have  $5^-$ -endvertices.

More formally, we claim that:

**Claim 2.28.** For all  $1 \leq i \leq 6$ ,  $\rho_H^*(vv_i) \leq 2$ .

*Chứng minh.* W.l.o.g. suppose by contradiction that  $\rho_H^*(vv_1) \geq 3$ . We add the 2-thread  $vp'_1p'_2v_1$  in  $H$  and let  $P' = \{p'_1, p'_2\}$  and let  $H + P'$  be the resulting graph. Since  $\rho_H^*(vv_1) \geq 3$ , by Lemma 2.7 with  $k = 2$ ,  $\text{mad}(H + P') \leq \frac{18}{7}$ . By minimality of  $G$ , there exists a coloring  $\psi$  of  $H + P'$ . We define  $\phi$  a coloring of  $G$  as follows:

- If  $x \in V(H)$ , then  $\phi(x) = \psi(x)$ .
- Let  $\phi(p_2) = \psi(p'_1)$ .
- Note that  $d_G^*(q'_i) \leq 7$  since  $d_G(v_i) \leq 5$  for all  $1 \leq i \leq 6$ . As a result, we can always color them last.
- Let  $L(x)$  be the list of available colors left for a vertex  $x$ . Observe that we have  $|L(p_1)| \geq 6$  and  $|L(u)|, |L(q_1)|, \dots, |L(q_6)| \geq 7$ . By Observation 2.26, the only way these eight vertices are not colorable is if  $|L(p_1) \cup L(u) \cup L(q_1) \cup \dots \cup L(q_6)| \leq 7$ . As a result,  $|L(u) \cup L(q_1)| = 7$  and  $|L(u)|, |L(q_1)| \geq 7$ . In other words,  $L(u) = L(q_1)$ . However,  $u$  sees  $\phi(p_2) = \psi(p'_1) \neq \psi(v_1) = \phi(v_1)$  which  $q_1$  sees. So  $L(u) \neq L(q_1)$ .

We obtain a valid coloring of  $G$  which is a contradiction.  $\square$

First, recall that  $\rho_{G-P}^*(u) \leq \rho_{G-P}^*(v)$  and by Lemma 2.22,  $\rho_{G-P}^*(v) \geq 1$ . As a result,  $\rho_H^*(v) \geq \rho_{G-P}^*(v) \geq 1$  by Equation (2.2).

Now, by Claim 2.28, we have  $\sum_{i=1}^6 \rho_H^*(vv_i) \leq 2 \cdot 6 = 12$ . However, by Equation (2.3), then Equation (2.4) and the fact that  $\rho_H^*(v) \geq 1$ , we have  $\sum_{i=1}^6 \rho_H^*(vv_i) \geq \rho_H^*(vv_1 \dots v_6) + 5\rho_H^*(v) \geq 12 + 5 \cdot 1 = 17$ . That contradiction completes the proof of Lemma 2.27.  $\square$

**Lemma 2.29.** Consider  $u$  a 7-vertex that is incident to a unique 3-thread  $up_1p_2p_3v$  and let  $P = \{p_1, p_2, p_3\}$ . If  $\rho_{G-P}^*(u) \leq \rho_{G-P}^*(v)$ , then  $u$  is incident to at most two 2-threads where the other endvertices are  $5^-$ -vertices.

*Chứng minh.* Note that by Lemma 2.15,  $u$  and  $v$  are distinct vertices and  $d(u) = d(v) = 7$ . Suppose by contradiction that  $u$  is incident to at least three 2-threads  $uq_1q'_1v_1$ ,  $uq_2q'_2v_2$ , and  $uq_3q'_3v_3$  where  $v_1, v_2$ , and  $v_3$  have degree at most 5. Note that by Lemma 2.16,  $u$  is distinct from  $v_i$  for all  $1 \leq i \leq 3$ . Let  $H = G - \{p_1, p_2, p_3, q_1, q'_1, q_2, q'_2, q_3, q'_3\}$ . Recall that  $\rho_{G-P}^*(u) \leq \rho_{G-P}^*(v)$  and by Lemma 2.22,  $\rho_{G-P}^*(v) \geq 1$ . As a result,  $\rho_H^*(v) \geq \rho_{G-P}^*(v) \geq 1$  by Equation (2.2).

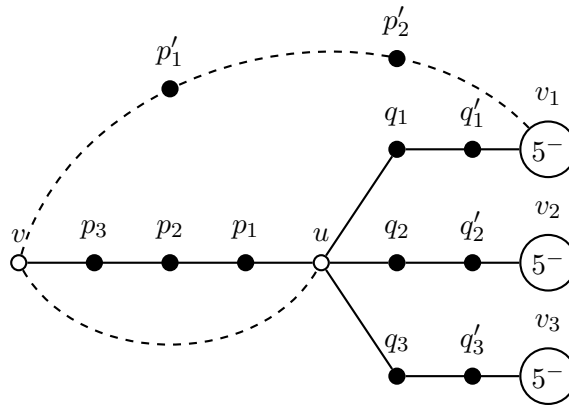

Hình 2.13: A 7-vertex incident to a 3-thread and three 2-threads which have  $5^-$ -endvertices.

We claim the following:

**Claim 2.30.** For all  $1 \leq i \leq 3$ ,  $\rho_H^*(vv_i) \leq 2$  and  $\rho_H^*(uv) \leq 6$ .

*Chứng minh.* Let us prove Claim 2.30 by contradiction.

First, suppose w.l.o.g. that  $\rho_H^*(vv_1) \geq 3$ . We add the 2-thread  $vp'_1p'_2v_1$  in  $H$ , let  $P' = \{p'_1, p'_2\}$ , and let  $H + P'$  be the resulting graph. Since  $\rho_H^*(vv_1) \geq 3$ , by Lemma 2.7 with  $k = 2$ ,  $\text{mad}(H + P') \leq \frac{18}{7}$ . By minimality of  $G$ , there exists a coloring  $\psi$  of  $H + P'$ . We define  $\phi$  a coloring of  $G$  as follows:

- If  $x \in V(H)$ , then  $\phi(x) = \psi(x)$ .
- Let  $\phi(p_3) = \psi(p'_1)$ .
- Note that  $d_G^*(q'_i) \leq \Delta = 7$  since  $d_G(v_i) \leq 5$  for all  $1 \leq i \leq 3$ . As a result, we can always color them last. The same holds for  $p_2$  since  $d_G^*(p_2) = 4$ .
- The only vertices left uncolored are  $p_1, q_1, q_2, q_3$  and each of them has at least three available colors left. By Observation 2.26, they can be colored unless they have exactly the same three available colors each. Since they all see the same four colors in  $N_H(u) \cup \{u\}$  and  $\phi(p_3) = \psi(p'_1) \neq \psi(v_1) = \phi(v_1)$ ,  $p_1$  and  $q_1$  cannot have the same three available colors.

We obtain a valid coloring  $\phi$  of  $G$ , so  $\rho_H^*(vv_i) \leq 2$  for all  $1 \leq i \leq 3$ .

Now, suppose that  $\rho_H^*(uv) \geq 7$ . We add the edge  $e = uv$  in  $H$ . Since  $\rho_H^*(uv) \geq 7$ , by Lemma 2.7 with  $k = 0$ ,  $\text{mad}(H + e) \leq \frac{18}{7}$ . By minimality of  $G$ , there exists a coloring  $\psi$  of  $H + e$ . We define  $\phi$  a coloring of  $G$  as follows:



- If  $x \in V(H)$ , then  $\phi(x) = \psi(x)$ .
- Let  $\phi(p_3) = \psi(u)$ .
- Note that  $d_G^*(q'_i) \leq \Delta = 7$  since  $d_G(v_i) \leq 5$  for all  $1 \leq i \leq 3$ . As a result, we can always color them last. The same holds for  $p_2$  since  $d_G^*(p_2) = 4$ .
- We color  $q_1, q_2, q_3$  which is possible since they have at least three available colors each.
- We finish by coloring  $p_1$  which sees eight colored vertices but since it sees  $\phi(u) = \phi(p_3)$  twice, it has at least one available color left.

We obtain a valid coloring  $\phi$  of  $G$ , so  $\rho_H^*(uv) \leq 6$ . Thus, Claim 2.30 is true.  $\square$

By Claim 2.30, we get  $\rho_H^*(uv) + \sum_{i=1}^3 \rho_H^*(vv_i) \leq 6 + 3 \cdot 2 = 12$ . However, by Equation (2.3) then by Equation (2.4) and recall that  $\rho_H^*(v) \geq 1$ , we get  $\rho_H^*(uv) + \sum_{i=1}^3 \rho_H^*(vv_i) \geq \rho_H^*(uvv_1v_2v_3) + 3\rho_H^*(v) \geq 10 + 3 \cdot 1 = 13$  which is a contradiction. That completes the proof of Lemma 2.29.  $\square$

**Lemma 2.31.** Consider  $u$  a 7-vertex that is incident to a unique 3-thread  $up_1p_2p_3v$  and let  $P = \{p_1, p_2, p_3\}$ . If  $\rho_{G-P}^*(u) \leq \rho_{G-P}^*(v)$ , then  $u$  has a neighbor that is neither a  $(2, 2, 0)$ -vertex nor a 2-vertex belonging to a 2-thread.

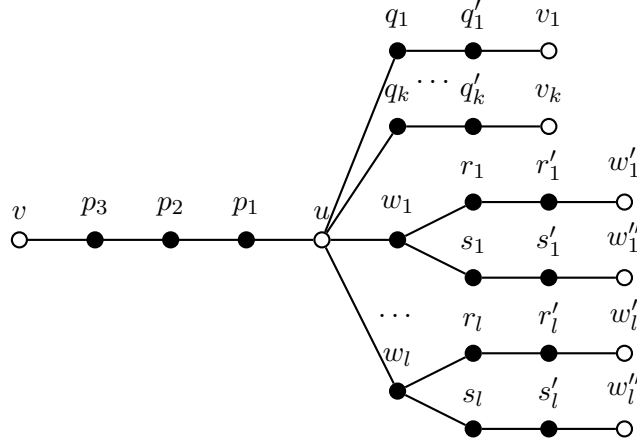

Hình 2.14: A 7-vertex that is incident to a 3-thread,  $k$  2-threads, and  $l$   $(2, 2, 0)$ -vertices where  $k + l = 6$ .

*Chứng minh.* Suppose by contradiction that  $u$  is incident to  $k$  2-threads  $uq_iq'_iv_i$  for  $1 \leq i \leq k$  and adjacent to  $l$   $(2, 2, 0)$ -vertices  $w_j$  for  $1 \leq j \leq l$  where  $k + l = 6$ . For all  $1 \leq j \leq l$ , let  $w_jr_jr'_jw'_j$  and  $w_js_js''_j$  be the 2-threads incident to  $w_j$ . Due to Lemma 2.15, Lemma 2.16, and Lemma 2.17,  $u$  is distinct from  $v, v_1, \dots, v_k, w_1, \dots, w_l, w'_1, \dots, w'_l, w''_1, \dots, w''_l$  and for all  $1 \leq j \leq l$ ,  $w_j$  is distinct from  $w'_1, \dots, w'_l, w''_1, \dots, w''_l$ .

We claim that:

**Claim 2.32.** For all subgraph  $H$  of  $G - P$ ,  $\rho_H^*(v) \geq 1$ .

*Chứng minh.* Indeed, recall that  $\rho_{G-P}^*(u) \leq \rho_{G-P}^*(v)$  and by Lemma 2.22,  $\rho_{G-P}^*(v) \geq 1$ . As a result,  $\rho_H^*(v) \geq \rho_{G-P}^*(v) \geq 1$  by Equation (2.2).  $\square$

Now we will prove the lemma for each possible value of  $0 \leq k \leq 6$ .

**Suppose that  $k = 0$ .**

Let  $H = G - (\{u, p_1, p_2\} \cup \{w_j, r_j, s_j | 1 \leq j \leq 6\})$ . By minimality of  $G$ , there exists a coloring of  $H$ . We will extend this coloring to  $G$ :

- If  $x \in V(H)$ , then  $\phi(x) = \psi(x)$ .
- Note that  $d_G^*(p_2) = 4$  and  $d_G^*(r_j) = d_G^*(s_j) = 5$  for all  $1 \leq j \leq 6$ , so we can always color them last.
- We color  $w_1, w_2, \dots, w_6$  since they have six available colors each.
- We color  $p_1$  then  $u$ .

We obtain a valid coloring of  $G$  so  $k \neq 0$ .

**Suppose that  $k = 1$ .**

Let  $H = G - (\{u, p_1, p_2, p_3, q_1, q'_1\} \cup \{w_j, r_j, s_j | 1 \leq j \leq 5\})$ . We add the 3-thread  $vp'_1p'_2p'_3v_1$  in  $H$ , let  $P' = \{p'_1, p'_2, p'_3\}$  and let  $H + P'$  be the resulting graph. Since  $\rho_H^*(vv_1) \geq \rho_H^*(v) \geq 1$  by Equation (2.1) and Claim 2.32, we get  $\text{mad}(H + P') \leq \frac{18}{7}$  by Lemma 2.7. By minimality of  $G$ , there exists a coloring  $\psi$  of  $H$ . We will extend  $\psi$  to a coloring  $\phi$  of  $G$ :

- If  $x \in V(H)$ , then  $\phi(x) = \psi(x)$ .
- Let  $\phi(p_3) = \psi(p'_1)$  and  $\phi(q'_1) = \psi(p'_3)$ .
- Note that  $d_G^*(p_2) = 4$  and  $d_G^*(r_j) = d_G^*(s_j) = 5$  for all  $1 \leq j \leq 5$  so we can always color them last.
- We color  $w_1, w_2, \dots, w_5$ , and  $q_1$  since they have six available colors each.
- We can color  $u$  and  $p_1$  unless they have exactly the same color left which is impossible since they see the same six colors in  $\{\phi(w_1), \phi(w_2), \dots, \phi(w_5), \phi(q_1)\}$  and  $p_1$  sees  $\phi(p_3) = \psi(p'_1) \neq \psi(p'_3) = \phi(q'_1)$  which  $u$  sees.

We obtain a valid coloring of  $G$  so  $k \neq 1$ .

**Suppose that  $k \geq 2$ .**

Let  $H = G - (\{u, p_1, p_2, p_3\} \cup \{q_i, q'_i | 1 \leq i \leq k\})$ . Note that  $\text{mad}(H) \leq \frac{18}{7}$  since  $H$  is a subgraph of  $G$ .

First, observe that by minimality of  $G$ , there exists a coloring  $\psi$  of  $H$ . If we can define a coloring  $\phi$  that extends  $\psi$  to  $G$ , then we obtain a contradiction. So, let us see the potential problems.

- First, if  $x \in V(H) \setminus \{w_j, r_j, s_j | 1 \leq j \leq l\}$ , then we repeat the same colors for  $x$ . Thus, let  $\phi(x) = \psi(x)$ .
- For all  $1 \leq i \leq k$ , we might have only one choice of colors for  $q'_i$  so we color them accordingly. The same holds for  $p_3$ .
- Since  $d_G^*(p_2) = 4$  and  $d_G^*(r_j) = d_G^*(s_j) = 5$  for all  $1 \leq j \leq l$ , we can always color them last.
- The remaining uncolored vertices are exactly  $N_G(u) \cup \{u\}$ . Let  $L(x)$  be the list of available colors left for a vertex  $x$ . Observe that  $|L(u)| \geq 8 - k \geq 2$ ,  $|L(q_1)|, \dots, |L(q_k)| \geq 6$ ,  $|L(w_1)|, \dots, |L(w_k)| \geq 6$ , and  $|L(p_1)| \geq 7$ .
- Due to Observation 2.26, the only two reasons that make these eight remaining vertices uncolorable are the following:

- We have seven vertices in  $N_G(u) \cup \{u\} \setminus \{p_1\}$  but  $|L(u) \cup L(q_1) \cup \dots \cup L(q_k) \cup L(w_1) \cup \dots \cup L(w_l)| \leq 6$ . Since  $|L(q_1)|, \dots, |L(q_k)|, |L(w_1)|, \dots, |L(w_k)| \geq 6$ , we have  $L(q_1) = \dots = L(q_k) = L(w_1) = \dots = L(w_l)$  and  $|L(q_1)| = 6$ . In other words,  $q_1, \dots, q_k, w_1, \dots, w_k$  all see the same two colors. More precisely,  $\{\phi(q'_1), \phi(v_1)\} = \dots = \{\phi(q'_k), \phi(v_k)\} = \{\phi(r'_1), \phi(s'_1)\} = \dots = \{\phi(r'_l), \phi(s'_l)\}$ .
- Or, we have eight vertices in  $N_G(u) \cup \{u\}$  but  $|L(u) \cup L(p_1) \cup L(q_1) \cup \dots \cup L(q_k) \cup L(w_1) \cup \dots \cup L(w_l)| \leq 7$ . Since  $|L(p_1)| \geq 7$ , we have  $|L(p_1)| = 7$ . Moreover,  $L(q_1), \dots, L(q_k), L(w_1), \dots, L(w_k) \subseteq L(p_1)$ . In other words,  $q_1, \dots, q_k, w_1, \dots, w_k$  all see  $\phi(p_3)$ . More precisely,  $\phi(p_3) \in \{\phi(q'_i), \phi(v_i)\}$  for all  $1 \leq i \leq k$  and  $\phi(p_3) \in \{\phi(r'_j), \phi(s'_j)\}$  for all  $1 \leq j \leq l$ .

To solve these two problems, the idea is to add two threads (or edges) to  $H$ , each one preventing one problem. If we can add these two threads, then we can define a valid coloring  $\phi$  of  $G$ , thus obtaining a contradiction. As a consequence, we cannot add both threads. However, it results in an upper bound on the potential of the endvertices of the added threads. In Claims 2.33 to 2.36, we show these upper bounds by using this technique of adding two threads to the graph  $H$  and constructing a valid coloring of  $G$ . Once we obtain all of these inequalities on the potential in  $H$  of  $v, v_1, \dots, v_k, w_1, \dots, w_l$ , we show, for each value of  $k$ , that the obtained set of inequalities is not feasible, thus obtaining a contradiction.

**Claim 2.33.** For  $k \geq 2$  and  $j \geq 1$ , if there exists  $1 \leq i \neq i' \leq k$  and  $1 \leq j \leq l$  such that  $\rho_H^*(v_i v_{i'}) \geq 3$  and  $\rho_H^*(v w_j) \geq 7$ , then  $\rho_H^*(v w_j v_i v_{i'}) \leq 9$ .

*Chứng minh.* Suppose by contradiction that, w.l.o.g.,  $\rho_H^*(v_1 v_2) \geq 3$ ,  $\rho_H^*(v w_1) \geq 7$ , and  $\rho_H^*(v w_1 v_1 v_2) \geq 10$ . We add the 2-thread  $v_1 p'_1 p'_2 v_2$  in  $H$ , let  $P' = \{p'_1, p'_2\}$ , and let  $H + P'$  be the resulting graph. Since  $\rho_H^*(v_1 v_2) \geq 3$ , we get  $\text{mad}(H + P') \leq \frac{18}{7}$  by Lemma 2.7. Observe that  $\rho_{H+P'}^*(v w_1) \geq 7$ , otherwise, by Lemma 2.9, we get  $6 \geq \rho_{H+P'}^*(v w_1) = \rho_H^*(v w_1) \geq 7$  or  $10 \leq \rho_H^*(v w_1 v_1 v_2) \leq 6 + 3 = 9$  which are both contradictions. Now, we add the edge  $e = v w_1$  in  $H + P'$  and by Lemma 2.7, we have  $\text{mad}(H + P' + e) \leq \frac{18}{7}$ . By minimality of  $G$ , there exists a coloring  $\psi$  of  $H + P' + e$ . We define  $\phi$  a coloring of  $G$  as follows:

- If  $x \in V(H) \setminus \{w_j, r_j, s_j | 1 \leq j \leq l\}$ , then  $\phi(x) = \psi(x)$ .
- We color  $q'_i$  for all  $3 \leq i \leq k$  since they all have at least one available color each.
- Let  $\phi(p_3) = \phi(w_1) = \psi(w_1)$ ,  $\phi(q'_1) = \psi(p'_1)$ , and  $\phi(q'_2) = \psi(p'_2)$ .
- Note that  $d_G^*(p_2) = 4$  and  $d_G^*(r_j) = d_G^*(s_j) = 5$  for all  $1 \leq j \leq l$ , so we can always color them last.
- We color  $u$  who has at least two available colors left as  $u$  sees  $\phi(q'_1), \dots, \phi(q'_k)$ , and  $\phi(w_1)$ .
- Then, we color  $w_2, \dots, w_l$  and  $q_3, \dots, q_k$  since there are three of them and each one has at least three available colors left.
- Now, we color  $q_1$  and  $q_2$  which each has at least one color left. These colors are different since  $q_1$  and  $q_2$  see the same five colors in  $\{\phi(u), \phi(w_1), \dots, \phi(w_l)\}$  and  $\{\phi(q_3), \dots, \phi(q_k)\}$  and  $q_1$  sees  $\{\phi(q'_1), \phi(v_1)\} = \{\psi(v_1), \psi(p'_1)\} \neq \{\psi(p'_2), \psi(v_2)\} = \{\phi(q'_2), \phi(v_2)\}$  which  $q_2$  sees.
- We color  $p_1$  since it sees eight colored vertices but two of them, namely  $w_1$  and  $p_3$  have the same color.

We obtain a valid coloring of  $G$  which is a contradiction.  $\square$

**Claim 2.34.** For  $k \geq 1$  and  $j \geq 2$ , if there exist  $1 \leq i \leq k$  and  $1 \leq j \neq j' \leq l$  such that  $\rho_H^*(v w_{j'}) \geq 7$  and  $\rho_H^*(v_i w_j) \geq 7$ , then  $\rho_H^*(v w_{j'} v_i w_j) \leq 13$ .

*Chứng minh.* Suppose by contradiction that, w.l.o.g.,  $\rho_H^*(vw_2) \geq 7$ ,  $\rho_H^*(v_1w_1) \geq 7$ , and  $\rho_H^*(vw_2v_1w_1) \geq 14$ . We add the edge  $e = vw_2$  in  $H$  and let  $H + e$  be the resulting graph. Since  $\rho_H^*(vw_2) \geq 7$ , we get  $\text{mad}(H + e) \leq \frac{18}{7}$  by Lemma 2.7. We have  $\rho_{H+e}^*(v_1w_1) \geq 7$ , otherwise, by Lemma 2.9, we get  $6 \geq \rho_{H+e}^*(v_1w_1) = \rho_H^*(v_1w_1) \geq 7$  or  $14 \leq \rho_H^*(vw_2v_1w_1) \leq 6 + 7 = 13$  which are both contradictions. Now, we add the edge  $e' = v_1w_1$  in  $H + e$ . So, by Lemma 2.7, we have  $\text{mad}(H + e + e') \leq \frac{18}{7}$ . By minimality of  $G$ , there exists a coloring  $\psi$  of  $H + e + e'$ . We define  $\phi$  a coloring of  $G$  as follows:

- If  $x \in V(H) \setminus \{w_j, r_j, s_j | 1 \leq j \leq l\}$ , then  $\phi(x) = \psi(x)$ .
- We color  $q'_i$  for all  $2 \leq i \leq k$  since they all have at least one available color each.
- Let  $\phi(p_3) = \phi(w_2) = \psi(w_2)$  and  $\phi(w_1) = \phi(q'_1) = \psi(q'_1)$ .
- Note that  $d_G^*(p_2) = 4$  and  $d_G^*(r_j) = d_G^*(s_j) = 5$  for all  $1 \leq j \leq l$ , so we can always color them last.
- We color  $u$  who has at least two available colors.
- Then, we color  $w_3, \dots, w_l$  and  $q_2, \dots, q_k$  since there are three of them and each one has three available colors left.
- Now, we color  $q_1$  which sees eight colored vertices but two of them, namely  $w_1$  and  $q'_1$  have the same color.
- Similarly, we can color  $p_1$  since it sees eight colored vertices but two of them, namely  $w_2$  and  $p_3$  have the same color.

We obtain a valid coloring of  $G$  which is a contradiction.  $\square$

**Claim 2.35.** For  $k \geq 3$ , if there exist three distinct integers  $1 \leq i, i', i'' \leq k$ ,  $\rho_H^*(vv_{i''}) \geq 3$  and  $\rho_H^*(v_i v_{i'}) \geq 3$ , then  $\rho_H^*(vv_i v_{i'} v_{i''}) \leq 5$ .

*Chứng minh.* Suppose by contradiction that, w.l.o.g.,  $i = 1, i' = 2, i'' = 3$ . In other words,  $\rho_H^*(vv_3) \geq 3$ ,  $\rho_H^*(v_1v_2) \geq 3$ , and  $\rho_H^*(vv_1v_2v_3) \geq 6$ . We add the 2-thread  $v_1p'_1p'_2v_2$  in  $H$  and let  $P' = \{p'_1, p'_2\}$ . Since  $\rho_H^*(v_1v_2) \geq 3$ , we get  $\text{mad}(H + P') \leq \frac{18}{7}$  by Lemma 2.7. We have  $\rho_{H+P'}^*(vv_3) \geq 3$ , otherwise, by Lemma 2.9, we get  $2 \geq \rho_{H+P'}^*(vv_3) = \rho_H^*(vv_3) \geq 3$  or  $6 \leq \rho_H^*(v_1v_2vv_3) \leq 2 + 3 = 5$  which are both contradictions. Now, we add the 2-thread  $vp''_1p''_2v_3$  in  $H + P'$  and let  $P'' = \{p''_1, p''_2\}$ . So, by Lemma 2.7, we have  $\text{mad}(H + P' + P'') \leq \frac{18}{7}$ . By minimality of  $G$ , there exists a coloring  $\psi$  of  $H + P' + P''$ . We define  $\phi$  a coloring of  $G$  as follows:

- If  $x \in V(H) \setminus \{w_j, r_j, s_j | 1 \leq j \leq l\}$ , then  $\phi(x) = \psi(x)$ .
- We color  $q'_i$  for all  $4 \leq i \leq k$  since they all have at least one available color each.
- Let  $\phi(p_3) = \psi(p''_1)$ ,  $\phi(q'_3) = \psi(p''_2)$ ,  $\phi(q'_1) = \psi(p'_1)$ , and  $\phi(q'_2) = \psi(p'_2)$ .
- Note that  $d_G^*(p_2) = 4$  and  $d_G^*(r_j) = d_G^*(s_j) = 5$  for all  $1 \leq j \leq l$ , so we can always color them last.
- Let  $L(x)$  be the list of available colors left for a vertex  $x$ . Observe that we have  $|L(u)| \geq 2$ ,  $|L(w_1)|, \dots, |L(w_l)|, |L(q_1)|, \dots, |L(q_k)| \geq 6$  and  $|L(p_1)| \geq 7$ . By Observation 2.26, the only two ways these eight vertices are not colorable is the following:
  - We have seven vertices  $u, w_1, \dots, w_l, q_1, \dots, q_l$  but  $|L(u) \cup L(w_1) \cup \dots \cup L(w_l) \cup L(q_1) \cup \dots \cup L(q_l)| \leq 6$ . However, this is not possible since  $q_1$  sees  $\{\phi(q'_1), \phi(v_1)\} = \{\psi(v_1), \psi(p'_1)\} \neq \{\psi(p'_2), \psi(v_2)\} = \{\phi(q'_2), \phi(v_2)\}$  which  $q_2$  sees. So,  $|L(q_1) \cup L(q_2)| \geq 7$ .

- We have  $|L(u) \cup L(p_1) \cup L(w_1) \cup \dots \cup L(w_l) \cup L(q_1) \cup \dots \cup L(q_l)| \leq 7$ . However, this is not possible since  $p_1$  sees  $\phi(p_3) = \psi(p'_1) \notin \{\psi(p'_2), \psi(v_3)\} = \{\phi(q'_3), \phi(v_3)\}$  which  $q_3$  sees. So,  $|L(p_1) \cup L(q_3)| \geq 8$ .

We obtain a valid coloring of  $G$  which is a contradiction.  $\square$

**Claim 2.36.** For  $k \geq 2$  and  $j \geq 1$ , if there exists  $1 \leq i \neq i' \leq k$  and  $1 \leq j \leq l$  such that  $\rho_H^*(vv_{i'}) \geq 3$  and  $\rho_H^*(v_i w_j) \geq 7$ , then  $\rho_H^*(vv_i v_i w_j) \leq 9$ .

*Chứng minh.* Suppose by contradiction that, w.l.o.g.,  $\rho_H^*(vv_2) \geq 3$ ,  $\rho_H^*(v_1 w_1) \geq 7$ , and  $\rho_H^*(vv_2 v_1 w_1) \geq 10$ . We add the 2-thread  $vp'_1 p'_2 v_2$  in  $H$  and let  $P' = \{p'_1, p'_2\}$ . Since  $\rho_H^*(vv_2) \geq 3$ , we get  $\text{mad}(H + P') \leq \frac{18}{7}$  by Lemma 2.7. We have  $\rho_{H+P'}^*(v_1 w_1) \geq 7$ , otherwise, by Lemma 2.9, we get  $6 \geq \rho_{H+P'}^*(v w_1) = \rho_H^*(v_1 w_1) \geq 7$  or  $10 \leq \rho_H^*(vv_2 v_1 w_1) \leq 6 + 3 = 9$  which are both contradictions. Now, we add the edge  $e = v_1 w_1$  in  $H + P'$ . So, by Lemma 2.7, we have  $\text{mad}(H + P' + e) \leq \frac{18}{7}$ . By minimality of  $G$ , there exists a coloring  $\psi$  of  $H + P' + e$ . We define  $\phi$  a coloring of  $G$  as follows:

- If  $x \in V(H) \setminus \{w_j, r_j, s_j | 1 \leq j \leq l\}$ , then  $\phi(x) = \psi(x)$ .
- We color  $q'_i$  for all  $3 \leq i \leq k$  since they all have at least one available color each.
- Let  $\phi(p_3) = \psi(p'_1)$ ,  $\phi(q'_2) = \psi(p'_2)$ , and  $\phi(q'_1) = \phi(w_1) = \psi(w_1)$ .
- Note that  $d_G^*(p_2) = 4$  and  $d_G^*(r_j) = d_G^*(s_j) = 5$  for all  $1 \leq j \leq l$ , so we can always color them last.
- Let  $L(x)$  be the list of available colors left for a vertex  $x$ . Observe that we have  $|L(u)| \geq 2$ ,  $|L(w_2)|, \dots, |L(w_l)|, |L(q_1)|, \dots, |L(q_k)| \geq 5$ , and  $|L(p_1)| \geq 6$ . By Observation 2.26, the only two ways these seven vertices are not colorable is the following:
  - We have six vertices  $u, w_2, \dots, w_l, q_1, \dots, q_l$  but  $|L(u) \cup L(w_1) \cup \dots \cup L(w_l) \cup L(q_1) \cup \dots \cup L(q_l)| \leq 5$ . However, this is not possible since  $q_1$  sees only three colored vertices:  $v_1, q'_1$ , and  $w_1$  and  $\phi(q'_1) = \phi(w_1)$ . So,  $|L(q_1)| \geq 6$ .
  - We have  $|L(u) \cup L(p_1) \cup L(w_1) \cup \dots \cup L(w_l) \cup L(q_1) \cup \dots \cup L(q_l)| \leq 6$ . However, this is not possible since  $p_1$  sees  $\phi(p_3) = \psi(p'_1) \notin \{\psi(p'_2), \psi(v_2)\} = \{\phi(q'_2), \phi(v_2)\}$  which  $q_2$  sees. So,  $|L(p_1) \cup L(q_2)| \geq 7$ .

We obtain a valid coloring of  $G$  which is a contradiction.  $\square$

Given Claims 2.33 to 2.36, we can show upper bounds on the potential on some subsets of vertices of  $G$ . However, due to Equation (2.4), the lower bounds on the potential of these subsets exceed the upper bounds, which is a contradiction.

First, recall that  $H = G - (\{u, p_1, p_2, p_3\} \cup \{q_i, q'_i | 1 \leq i \leq k\})$  and observe that:

**Observation 2.37.** For  $0 \leq i \leq k$  and  $0 \leq j \leq l$ , by applying Equation (2.4) to the graph  $G - \{up_1, uq_{i+1}, \dots, uq_k, uw_{j+1}, \dots, uw_l\}$  with  $A = \{u\} \cup \{q_x, q'_x | 1 \leq x \leq i\}$  and  $S = \{v_1, \dots, v_i, w_1, \dots, w_j\}$ , we have  $\rho_H^*(S) \geq 3i + 7j - 9$ . Similarly, by applying Equation (2.4) to the graph  $G - \{uq_{i+1}, \dots, uq_k, uw_{j+1}, \dots, uw_l\}$  with  $A = \{u, p_1, p_2, p_3\} \cup \{q_x, q'_x | 1 \leq x \leq i\}$  and  $S = \{v, v_1, \dots, v_i, w_1, \dots, w_j\}$ ,  $\rho_H^*(S) \geq 3i + 7j - 8$ .

Indeed, by Equation (2.4), we obtain the first inequality through the following calculations:

$$\begin{aligned}
 \rho_H^*(S) &\geq 7(i + j) - (9(2i + 1) - 7 \cdot 2i) \\
 &\geq 7i + 7j - (18i + 9 - 14i) \\
 &\geq 7i + 7j - 18i - 9 + 14i \\
 &\geq 3i + 7j - 9
 \end{aligned}$$

Similarly, we can obtain the second equation through the same kind of calculations.

Now, we consider the different values of  $2 \leq k \leq 6$ .

**For  $k = 2$ :**

- Suppose that  $\rho_H^*(vw_j) \leq 6$  for all  $1 \leq j \leq 4$ .  
As a result, for all  $1 \leq i \leq 2$ ,  $\rho_H^*(vw_1) + \dots + \rho_H^*(vw_4) + \rho_H^*(vv_i) \leq 6 \cdot 4 + \rho_H^*(vv_i) = 24 + \rho_H^*(vv_i)$ . We also have  $\rho_H^*(vw_1) + \dots + \rho_H^*(vw_4) + \rho_H^*(vv_i) \geq \rho_H^*(vv_i w_1 \dots w_4) + 4\rho_H^*(v) \geq 3 \cdot 1 + 7 \cdot 4 - 8 + 4\rho_H^*(v) \geq 23 + 4 \cdot 1 = 27$  where the first inequality corresponds to Equation (2.3), the second one to Observation 2.37, and the third one to Claim 2.32 (from now on, we will repeat the same scheme). So,  $\rho_H^*(vv_i) \geq 27 - 24 = 3$  for all  $1 \leq i \leq 2$ .  
Suppose there exist  $1 \leq i \leq 2$  and  $1 \leq j \leq 4$  such that  $\rho_H^*(v_i w_j) \geq 7$ . Say w.l.o.g. that  $\rho_H^*(v_2 w_2) \geq 7$ , then by Claim 2.36,  $\rho_H^*(vv_1 v_2 w_2) \leq 9$ . Thus, we get  $\rho_H^*(vv_1 v_2 w_2) + \rho_H^*(vw_1) + \rho_H^*(vw_3) + \rho_H^*(vw_4) \leq 9 + 3 \cdot 6 = 27$ . However, by Equation (2.3), Observation 2.37 then Claim 2.32, we have  $\rho_H^*(vv_1 v_2 w_2) + \rho_H^*(vw_1) + \rho_H^*(vw_3) + \rho_H^*(vw_4) \geq \rho_H^*(vv_1 v_2 w_1 \dots w_4) + 3\rho_H^*(v) \geq 3 \cdot 2 + 7 \cdot 4 - 8 + 3\rho_H^*(v) \geq 26 + 3 = 29$ .  
So, for all  $1 \leq i \leq 2$  and  $1 \leq j \leq 4$ ,  $\rho_H^*(v_i w_j) \leq 6$ . Thus, we get  $\rho_H^*(v_1 w_1) + \rho_H^*(v_2 w_2) + \rho_H^*(v w_3) + \rho_H^*(v w_4) \leq 4 \cdot 6 = 24$ . However, by Equation (2.3), Observation 2.37 then Claim 2.32, we have  $\rho_H^*(v_1 w_1) + \rho_H^*(v_2 w_2) + \rho_H^*(v w_3) + \rho_H^*(v w_4) \geq \rho_H^*(vv_1 v_2 w_1 \dots w_4) + \rho_H^*(v) \geq 3 \cdot 2 + 7 \cdot 4 - 8 + \rho_H^*(v) \geq 26 + 1 = 27$ .
- Suppose w.l.o.g. that  $\rho_H^*(v w_1) \geq 7$ .
  - Suppose that for all  $1 \leq i \leq 2$  and  $2 \leq j \leq 4$ , we have  $\rho_H^*(v_i w_j) \leq 6$ .  
As a result,  $\rho_H^*(v_2 w_2) + \rho_H^*(v_1 w_3) + \rho_H^*(v_1 w_4) + \rho_H^*(v_1 w_1) \leq 3 \cdot 6 + \rho_H^*(v_1 w_1) = 18 + \rho_H^*(v_1 w_1)$ . Moreover, by Equation (2.3) then Observation 2.37,  $\rho_H^*(v_2 w_2) + \rho_H^*(v_1 w_3) + \rho_H^*(v_1 w_4) + \rho_H^*(v_1 w_1) \geq \rho_H^*(v_1 v_2 w_1 \dots w_4) + 2\rho_H^*(v_1) \geq 3 \cdot 2 + 7 \cdot 4 - 9 = 25$ . So, we get  $\rho_H^*(v_1 w_1) \geq 25 - 18 = 7$ .  
Suppose there exists  $2 \leq j \leq 4$  such that  $\rho_H^*(v w_j) \geq 7$ . Say w.l.o.g. that  $\rho_H^*(v w_2) \geq 7$ , then by Claim 2.34,  $\rho_H^*(v_1 w_1 v w_2) \leq 13$ . We get  $\rho_H^*(v_1 w_1 v w_2) + \rho_H^*(v_2 w_3) + \rho_H^*(v_2 w_4) \leq 13 + 2 \cdot 6 = 25$ . However, by Equation (2.3) then Observation 2.37,  $\rho_H^*(v_1 w_1 v w_2) + \rho_H^*(v_2 w_3) + \rho_H^*(v_2 w_4) \geq \rho_H^*(vv_1 v_2 w_1 \dots w_4) + \rho_H^*(v_2) \geq 3 \cdot 2 + 7 \cdot 4 - 8 = 26$ .  
So,  $\rho_H^*(v w_j) \leq 6$  for all  $2 \leq j \leq 4$ . We get  $\rho_H^*(v w_2) + \rho_H^*(v_1 w_3) + \rho_H^*(v_2 w_4) \leq 3 \cdot 6 = 18$ . However, by Equation (2.3) then Observation 2.37,  $\rho_H^*(v w_2) + \rho_H^*(v_1 w_3) + \rho_H^*(v_2 w_4) \geq \rho_H^*(vv_1 v_2 w_2 w_3 w_4) \geq 3 \cdot 2 + 7 \cdot 3 - 8 = 19$ .
  - Suppose that there exist  $1 \leq i \leq 2$  and  $2 \leq j \leq 4$  such that  $\rho_H^*(v_i w_j) \geq 7$ . Say w.l.o.g.  $\rho_H^*(v_2 w_2) \geq 7$ .  
By Claim 2.34,  $\rho_H^*(v w_1 v_2 w_2) \leq 13$ . As a result, by Equation (2.3) then Observation 2.37, we get  $\rho_H^*(v w_1 v_2 w_2) + \rho_H^*(v_1 w_3) + \rho_H^*(v_1 w_4) \geq \rho_H^*(vv_1 v_2 w_1 \dots w_4) + \rho_H^*(v_1) \geq 3 \cdot 2 + 7 \cdot 4 - 8 = 26$ . So,  $\rho_H^*(v_1 w_3) + \rho_H^*(v_1 w_4) \geq 26 - 13 = 13$  and  $\rho_H^*(v_1 w_3) \geq 7$  w.l.o.g.  
By Claim 2.34,  $\rho_H^*(v w_1 v_1 w_3) \leq 13$ . As a result, by Equation (2.3) then Observation 2.37, we get  $\rho_H^*(v w_1 v_2 w_2) + \rho_H^*(v w_1 v_1 w_3) + \rho_H^*(v_1 w_4) \geq \rho_H^*(vv_1 v_2 w_1 \dots w_4) + \rho_H^*(v w_1) + \rho_H^*(v_1) \geq 3 \cdot 2 + 7 \cdot 4 - 8 + 7 = 33$ . So,  $\rho_H^*(v_1 w_4) \geq 33 - 2 \cdot 13 = 7$ .  
By Claim 2.34,  $\rho_H^*(v w_1 v_1 w_4) \leq 13$ . Finally, we have  $\rho_H^*(v w_1 v_2 w_2) + \rho_H^*(v w_1 v_1 w_3) + \rho_H^*(v w_1 v_1 w_4) \leq 3 \cdot 13 = 39$ . However, by Equation (2.3) then Observation 2.37,  $\rho_H^*(v w_1 v_2 w_2) + \rho_H^*(v w_1 v_1 w_3) + \rho_H^*(v w_1 v_1 w_4) \geq \rho_H^*(vv_1 v_2 w_1 \dots w_4) + 2\rho_H^*(v w_1) + \rho_H^*(v_1) \geq 3 \cdot 2 + 7 \cdot 4 - 8 + 2 \cdot 7 = 40$ .

**For  $k = 3$ :**

Suppose that  $\rho_H^*(v w_j) \leq 6$  for all  $1 \leq j \leq 3$ .

Let  $\{i, i', i''\}$  be any permutation of  $\{1, 2, 3\}$ ,  $\rho_H^*(v w_1) + \rho_H^*(v w_2) + \rho_H^*(v w_3) + \rho_H^*(v_i v_{i'}) \leq 3 \cdot 6 + \rho_H^*(v_i v_{i'}) = 18 + \rho_H^*(v_i v_{i'})$ . Moreover, by Equation (2.3), Observation 2.37 then Claim 2.32,

$\rho_H^*(vw_1) + \rho_H^*(vw_2) + \rho_H^*(vw_3) + \rho_H^*(v_i v_{i'}) \geq \rho_H^*(vv_i v_{i'} w_1 w_2 w_3) + 2\rho_H^*(v) \geq 3 \cdot 2 + 7 \cdot 3 - 8 + 2 = 21$ . So, we get  $\rho_H^*(v_i v_{i'}) \geq 21 - 18 = 3$ .

If  $\rho_H^*(vv_{i''}) \geq 3$ , then by Claim 2.35,  $\rho_H^*(vv_i v_{i'} v_{i''}) \leq 5$ . Since  $\rho_H^*(vv_i v_{i'} v_{i''}) = \rho_H^*(vv_1 v_2 v_3)$ , we get  $\rho_H^*(vw_1) + \rho_H^*(vw_2) + \rho_H^*(vw_3) + \rho_H^*(vv_1 v_2 v_3) \leq 3 \cdot 6 + 5 = 23$ . However, by Equation (2.3), Observation 2.37 then Claim 2.32,  $\rho_H^*(vw_1) + \rho_H^*(vw_2) + \rho_H^*(vw_3) + \rho_H^*(vv_1 v_2 v_3) \geq \rho_H^*(vv_1 v_2 v_3 w_1 w_2 w_3) + 3\rho_H^*(v) \geq 3 \cdot 3 + 7 \cdot 3 - 8 + 3 = 25$ .

Observe the previous argument holds for any permutation of  $\{i, i', i''\} = \{1, 2, 3\}$ . So  $\rho_H^*(vv_{i''}) \leq 2$  for all  $1 \leq i'' \leq 3$ . Thus, we get  $\rho_H^*(vw_1) + \rho_H^*(vw_2) + \rho_H^*(vw_3) + \rho_H^*(vv_1) + \rho_H^*(vv_2) + \rho_H^*(vv_3) \leq 3 \cdot 6 + 3 \cdot 2 = 24$ . However, by Equation (2.3), Observation 2.37 then Claim 2.32,  $\rho_H^*(vw_1) + \rho_H^*(vw_2) + \rho_H^*(vw_3) + \rho_H^*(vv_1) + \rho_H^*(vv_2) + \rho_H^*(vv_3) \geq \rho_H^*(vv_1 v_2 v_3 w_1 w_2 w_3) + 5\rho_H^*(v) \geq 3 \cdot 3 + 7 \cdot 3 - 8 + 5 = 27$ .

Now, suppose there exists  $1 \leq j \leq 3$  such that  $\rho_H^*(vw_j) \geq 7$ . Say w.l.o.g. that  $\rho_H^*(vw_1) \geq 7$ .

- Suppose that there exist  $1 \leq i \leq 3$  and  $2 \leq j \leq 3$  such that  $\rho_H^*(v_i w_j) \geq 7$ . Say w.l.o.g. that  $\rho_H^*(v_3 w_3) \geq 7$ . By Claim 2.34,  $\rho_H^*(vw_1 v_3 w_3) \leq 13$ .

– If  $\rho_H^*(v_1 v_2) \leq 2$ , then  $\rho_H^*(vw_1 v_3 w_3) + \rho_H^*(v_1 v_2) + \rho_H^*(v_2 w_2) \leq 13 + 2 + \rho_H^*(v_2 w_2) = 15 + \rho_H^*(v_2 w_2)$ . By Equation (2.3) then Observation 2.37,  $\rho_H^*(vw_1 v_3 w_3) + \rho_H^*(v_1 v_2) + \rho_H^*(v_2 w_2) \geq \rho_H^*(vv_1 v_2 v_3 w_1 w_2 w_3) + \rho_H^*(v_2) \geq 3 \cdot 3 + 7 \cdot 3 - 8 = 22$ . So,  $\rho_H^*(v_2 w_2) \geq 22 - 15 = 7$ .

By Claim 2.34,  $\rho_H^*(vw_1 v_2 w_2) \leq 13$ . Thus, we get  $\rho_H^*(vw_1 v_2 w_2) + \rho_H^*(vw_1 v_3 w_3) + \rho_H^*(v_1 v_2) \leq 2 \cdot 13 + 2 = 28$ . However, by Equation (2.3) then Observation 2.37,  $\rho_H^*(vw_1 v_2 w_2) + \rho_H^*(vw_1 v_3 w_3) + \rho_H^*(v_1 v_2) \geq \rho_H^*(vv_1 v_2 v_3 w_1 w_2 w_3) + \rho_H^*(vw_1) + \rho_H^*(v_2) \geq 3 \cdot 3 + 7 \cdot 3 - 8 + 7 = 29$ .

– If  $\rho_H^*(v_1 v_2) \geq 3$ , then by Claim 2.33,  $\rho_H^*(vw_1 v_1 v_2) \leq 9$ . So, we get  $\rho_H^*(vw_1 v_1 v_2) + \rho_H^*(vw_1 v_3 w_3) + \rho_H^*(v_2 w_2) \leq 9 + 13 + \rho_H^*(v_2 w_2) = 22 + \rho_H^*(v_2 w_2)$ . By Equation (2.3) then Observation 2.37,  $\rho_H^*(vw_1 v_1 v_2) + \rho_H^*(vw_1 v_3 w_3) + \rho_H^*(v_2 w_2) \geq \rho_H^*(vv_1 v_2 v_3 w_1 w_2 w_3) + \rho_H^*(vw_1) + \rho_H^*(v_2) \geq 3 \cdot 3 + 7 \cdot 3 - 8 + 7 = 29$ . As a result,  $\rho_H^*(v_2 w_2) \geq 29 - 22 = 7$ .

By Claim 2.34,  $\rho_H^*(vw_1 v_2 w_2) \leq 13$ . Thus,  $\rho_H^*(vw_1 v_3 w_3) + \rho_H^*(vw_1 v_2 w_2) + \rho_H^*(vw_1 v_1 v_2) \leq 2 \cdot 13 + 9 = 35$ . However, by Equation (2.3) then Observation 2.37,  $\rho_H^*(vw_1 v_3 w_3) + \rho_H^*(vw_1 v_2 w_2) + \rho_H^*(vw_1 v_1 v_2) \geq \rho_H^*(vv_1 v_2 v_3 w_1 w_2 w_3) + 2\rho_H^*(vw_1) + \rho_H^*(v_2) \geq 3 \cdot 3 + 7 \cdot 3 - 8 + 2 \cdot 7 = 36$ .

- Suppose that  $\rho_H^*(v_i w_j) \leq 6$  for all  $1 \leq i \leq 3$  and  $2 \leq j \leq 3$ .

If  $\rho_H^*(v_1 v_2) \geq 3$ , then by Claim 2.33,  $\rho_H^*(vw_1 v_1 v_2) \leq 9$ . Thus,  $\rho_H^*(vw_1 v_1 v_2) + \rho_H^*(v_2 w_2) + \rho_H^*(v_3 w_3) \leq 9 + 2 \cdot 6 = 21$ . However, by Equation (2.3) then Observation 2.37,  $\rho_H^*(vw_1 v_1 v_2) + \rho_H^*(v_2 w_2) + \rho_H^*(v_3 w_3) \geq \rho_H^*(vv_1 v_2 v_3 w_1 w_2 w_3) + \rho_H^*(v_2) \geq 3 \cdot 3 + 7 \cdot 3 - 8 = 22$ .

So,  $\rho_H^*(v_1 v_2) \leq 2$ . Thus,  $\rho_H^*(v_1 v_2) + \rho_H^*(v_2 w_2) + \rho_H^*(v_3 w_3) \leq 2 + 2 \cdot 6 = 14$ . Moreover, by Equation (2.3) then Observation 2.37,  $\rho_H^*(v_1 v_2) + \rho_H^*(v_2 w_2) + \rho_H^*(v_3 w_3) \geq \rho_H^*(v_1 v_2 v_3 w_2 w_3) + \rho_H^*(v_2) \geq 3 \cdot 3 + 7 \cdot 2 - 9 + \rho_H^*(v_2) = 14 + \rho_H^*(v_2)$ . As a result,  $\rho_H^*(v_2) \leq 14 - 14 = 0$ . However,  $\rho_H^*(v_1 w_2) + \rho_H^*(v_3 w_3) + \rho_H^*(v_2) \leq 2 \cdot 6 + 0 = 12$  and by Equation (2.3) then Observation 2.37,  $\rho_H^*(v_1 w_2) + \rho_H^*(v_3 w_3) + \rho_H^*(v_2) \geq \rho_H^*(v_1 v_2 v_3 w_2 w_3) \geq 3 \cdot 3 + 7 \cdot 2 - 9 = 14$ .

#### For $k = 4$ :

If  $\rho_H^*(v_1 v_2) \leq 2$  and  $\rho_H^*(v_3 v_4) \leq 2$ , then  $\rho_H^*(v_1 v_2) + \rho_H^*(v_3 v_4) + \rho_H^*(w_1) + \rho_H^*(w_2) \leq 4 + \rho_H^*(w_1) + \rho_H^*(w_2)$ . Moreover, by Equation (2.3) then Observation 2.37,  $\rho_H^*(v_1 v_2) + \rho_H^*(v_3 v_4) + \rho_H^*(w_1) + \rho_H^*(w_2) \geq \rho_H^*(v_1 v_2 v_3 v_4 w_1 w_2) \geq 3 \cdot 4 + 7 \cdot 2 - 9 = 17$ . As a result,  $\rho_H^*(w_1) + \rho_H^*(w_2) \geq 17 - 4 = 13$ . So,  $\rho_H^*(w_1) \geq 7$  w.l.o.g. and by Equation (2.1),  $\rho_H^*(w_1 v_i) \geq 7$  for all  $1 \leq i \leq 4$ .

At the same time,  $\rho_H^*(v_1 v_2) + \rho_H^*(v_3 v_4) + \rho_H^*(vw_2) \leq 4 + \rho_H^*(vw_2)$ . Moreover, by Equation (2.3) then Observation 2.37,  $\rho_H^*(v_1 v_2) + \rho_H^*(v_3 v_4) + \rho_H^*(vw_2) \geq \rho_H^*(vv_1 v_2 v_3 v_4 w_2) \geq 3 \cdot 4 + 7 - 8 = 11$ . As a result,  $\rho_H^*(vw_2) \geq 11 - 4 = 7$ .

By Claim 2.34, we get  $\rho_H^*(vw_2w_1v_i) \leq 13$  for all  $1 \leq i \leq 4$ . As a result, we have  $\rho_H^*(v_1v_2) + \rho_H^*(v_3v_4) + \rho_H^*(vw_1w_2v_1) \leq 2 \cdot 2 + 13 = 17$ . However, by Equation (2.3) then Observation 2.37,  $\rho_H^*(v_1v_2) + \rho_H^*(v_3v_4) + \rho_H^*(vw_1w_2v_1) \geq \rho_H^*(vv_1v_2v_3v_4w_1w_2) + \rho_H^*(v_1) \geq 3 \cdot 4 + 7 \cdot 2 - 8 = 18$ .

Thus, we can suppose w.l.o.g. that  $\rho_H^*(v_1v_2) \geq 3$ .

- Suppose that  $\rho_H^*(vw_1) \leq 6$  and  $\rho_H^*(vw_2) \leq 6$ .
  - Suppose that  $\rho_H^*(vv_3) \leq 2$  and  $\rho_H^*(vv_4) \leq 2$ .  
Then  $\rho_H^*(vw_1) + \rho_H^*(vw_2) + \rho_H^*(vv_3) + \rho_H^*(vv_4) + \rho_H^*(v_1) + \rho_H^*(v_2) \leq 2 \cdot 6 + 2 \cdot 2 + \rho_H^*(v_1) + \rho_H^*(v_2) = 16 + \rho_H^*(v_1) + \rho_H^*(v_2)$ . Moreover, by Equation (2.3), Observation 2.37 then Claim 2.32,  $\rho_H^*(vw_1) + \rho_H^*(vw_2) + \rho_H^*(vv_3) + \rho_H^*(vv_4) + \rho_H^*(v_1) + \rho_H^*(v_2) \geq \rho_H^*(vv_1v_2v_3v_4w_1w_2) + 3\rho_H^*(v) \geq 3 \cdot 4 + 7 \cdot 2 - 8 + 3 \cdot 1 = 21$ . As a result,  $\rho_H^*(v_1) + \rho_H^*(v_2) \geq 21 - 16 = 5$ . So,  $\rho_H^*(v_1) \geq 3$  w.l.o.g. and by Equation (2.1)  $\rho_H^*(v_1v_i) \geq 3$  for all  $2 \leq i \leq 4$ .  
If  $\rho_H^*(vv_2) \geq 3$ , then  $\rho_H^*(vv_2v_1v_3) \leq 5$  and  $\rho_H^*(vv_2v_1v_4) \leq 5$  by Claim 2.35. As a result,  $22 = 2 \cdot 6 + 2 \cdot 5 \geq \rho_H^*(vw_1) + \rho_H^*(vw_2) + \rho_H^*(vv_2v_1v_3) + \rho_H^*(vv_2v_1v_4) \geq \rho_H^*(vv_1v_2v_3v_4w_1w_2) + \rho_H^*(vv_1v_2) + 2\rho_H^*(v) \geq 3 \cdot 4 + 7 \cdot 2 - 8 + 3 + 2 \cdot 1 = 23$  by Equation (2.3), Observation 2.37 then Equation (2.1) and Claim 2.32.  
If  $\rho_H^*(vv_2) \leq 2$ , then  $18 = 3 \cdot 2 + 2 \cdot 6 \geq \rho_H^*(vv_2) + \rho_H^*(vv_3) + \rho_H^*(vv_4) + \rho_H^*(vw_1) + \rho_H^*(vw_2) \geq \rho_H^*(vv_2v_3v_4w_1w_2) + 4\rho_H^*(v) \geq 3 \cdot 3 + 7 \cdot 2 - 8 + 4 \cdot 1 = 19$  by Equation (2.3), Observation 2.37 then Claim 2.32.
  - Suppose w.l.o.g. that  $\rho_H^*(vv_3) \geq 3$ .  
Then, by Claim 2.35,  $\rho_H^*(vv_3v_1v_2) \leq 5$ . As a result,  $\rho_H^*(vv_3v_1v_2) + \rho_H^*(vw_1) + \rho_H^*(vw_2) + \rho_H^*(vv_4) \leq 5 + 2 \cdot 6 + \rho_H^*(vv_4) = 17 + \rho_H^*(vv_4)$ . Moreover, by Equation (2.3), Observation 2.37 then Claim 2.32,  $\rho_H^*(vv_3v_1v_2) + \rho_H^*(vw_1) + \rho_H^*(vw_2) + \rho_H^*(vv_4) \geq \rho_H^*(vv_1v_2v_3v_4w_1w_2) + 3\rho_H^*(v) \geq 3 \cdot 4 + 7 \cdot 2 - 8 + 3 \cdot 1 = 21$ . So,  $\rho_H^*(vv_4) \geq 21 - 17 = 4$ .  
Thus, by Claim 2.35,  $\rho_H^*(vv_4v_1v_2) \leq 5$ . Finally,  $22 = 2 \cdot 6 + 2 \cdot 5 \geq \rho_H^*(vw_1) + \rho_H^*(vw_2) + \rho_H^*(vv_3v_1v_2) + \rho_H^*(vv_4v_1v_2) \geq \rho_H^*(vv_1v_2v_3v_4w_1w_2) + \rho_H^*(vv_1v_2) + 2\rho_H^*(v) \geq 3 \cdot 4 + 7 \cdot 2 - 8 + 3 + 2 \cdot 1 = 23$  by Equation (2.3), Observation 2.37 then Equation (2.1), and Claim 2.32.
- Suppose w.l.o.g. that  $\rho_H^*(vw_1) \geq 7$ , by Claim 2.33,  $\rho_H^*(vw_1v_1v_2) \leq 9$ .  
If  $\rho_H^*(v_3v_4) \geq 3$ , then by Claim 2.33,  $\rho_H^*(vw_1v_3v_4) \leq 9$ . As a result,  $\rho_H^*(vw_1v_1v_2) + \rho_H^*(vw_1v_3v_4) + \rho_H^*(vw_2) \leq 2 \cdot 9 + \rho_H^*(vw_2) = 18 + \rho_H^*(vw_2)$ . Moreover, by Equation (2.3), Observation 2.37 then Claim 2.32,  $\rho_H^*(vw_1v_1v_2) + \rho_H^*(vw_1v_3v_4) + \rho_H^*(vw_2) \geq \rho_H^*(vv_1v_2v_3v_4w_1w_2) + \rho_H^*(vw_1) + \rho_H^*(v) \geq 3 \cdot 4 + 7 \cdot 2 - 8 + 7 + 1 = 26$ . So,  $\rho_H^*(vw_2) \geq 26 - 18 = 8$ . Thus, by Claim 2.33,  $\rho_H^*(vw_2v_3v_4) \leq 9$ . Finally,  $18 = 2 \cdot 9 \geq \rho_H^*(vw_1v_1v_2) + \rho_H^*(vw_2v_3v_4) \geq \rho_H^*(vv_1v_2v_3v_4w_1w_2) + \rho_H^*(v) \geq 3 \cdot 4 + 7 \cdot 2 - 8 + 1 = 19$  by Equation (2.3), Observation 2.37, and Claim 2.32.  
If  $\rho_H^*(v_3v_4) \leq 2$ , then we get  $\rho_H^*(vw_1v_1v_2) + \rho_H^*(v_3v_4) + \rho_H^*(vw_2) \leq 9 + 2 + \rho_H^*(vw_2) = 11 + \rho_H^*(vw_2)$ . Moreover, by Equation (2.3), Observation 2.37 then Claim 2.32,  $\rho_H^*(vw_1v_1v_2) + \rho_H^*(v_3v_4) + \rho_H^*(vw_2) \geq \rho_H^*(vv_1v_2v_3v_4w_1w_2) + \rho_H^*(v) \geq 3 \cdot 4 + 7 \cdot 2 - 8 + 1 = 19$ . As a result,  $\rho_H^*(vw_2) \geq 19 - 11 = 8$  and by Claim 2.33,  $\rho_H^*(vw_2v_1v_2) \leq 9$ . Finally,  $20 = 2 \cdot 9 + 2 \geq \rho_H^*(vw_1v_1v_2) + \rho_H^*(vw_2v_1v_2) + \rho_H^*(v_3v_4) \geq \rho_H^*(vv_1v_2v_3v_4w_1w_2) + \rho_H^*(vv_1v_2) \geq 3 \cdot 4 + 7 \cdot 2 - 8 + 3 = 21$  by Equation (2.3), Observation 2.37, and Equation (2.1).

**For  $k = 5$ :**

- Suppose that  $\rho_H^*(vw_1) \leq 6$ .  
As a result,  $\rho_H^*(vw_1) + \rho_H^*(vv_1v_2v_3v_4v_5) \leq 6 + \rho_H^*(vv_1v_2v_3v_4v_5)$ . Moreover, by Equation (2.3), Observation 2.37 then Claim 2.32,  $\rho_H^*(vw_1) + \rho_H^*(vv_1v_2v_3v_4v_5) \geq \rho_H^*(vv_1v_2v_3v_4v_5w_1) + \rho_H^*(v) \geq 3 \cdot 5 + 7 - 8 + 1 = 15$ . So,  $\rho_H^*(vv_1v_2v_3v_4v_5) \geq 15 - 6 = 9$ .



By Equation (2.3), Observation 2.37 then Claim 2.32,  $\sum_{i=1}^5 \rho^*(vv_i) \geq \rho_H^*(vv_1v_2v_3v_4v_5) + 4\rho_H^*(v) \geq 9 + 4 = 13$ . So, there exists  $1 \leq i \leq 5$  such that  $\rho_H^*(vv_i) \geq 3$ .

Say w.l.o.g. that  $\rho^*(vv_1) \geq 3$ .

If  $\rho^*(v_i v_j) \leq 2$  for all  $2 \leq i \neq j \leq 5$ , then  $\rho_H^*(v_2v_3) + \rho_H^*(v_4v_5) + \rho_H^*(vw_1) \leq 2 \cdot 2 + 6 = 10$ . However, by Equation (2.3), Observation 2.37 then Claim 2.32,  $\rho_H^*(v_2v_3) + \rho_H^*(v_4v_5) + \rho_H^*(vw_1) \geq \rho_H^*(vv_2v_3v_4v_5w_1) \geq 3 \cdot 4 + 7 - 8 = 11$ .

So, there exist  $2 \leq i \neq j \leq 5$  such that  $\rho_H^*(v_i v_j) \geq 3$ . Say w.l.o.g. that  $\rho_H^*(v_2v_3) \geq 3$ .

By Claim 2.35,  $\rho_H^*(vv_1v_2v_3) \leq 5$ . Moreover, by Equation (2.3), Observation 2.37 then Claim 2.32,  $\rho_H^*(vv_1v_2v_3) + \rho_H^*(vw_1) + \rho_H^*(v_4v_5) \geq \rho_H^*(vv_1v_2v_3v_4v_5w_1) + \rho_H^*(v) \geq 3 \cdot 5 + 7 - 8 + 1 = 15$ . As a result,  $5 + 6 + \rho_H^*(v_4v_5) \geq \rho_H^*(vv_1v_2v_3) + \rho_H^*(vw_1) + \rho_H^*(v_4v_5) \geq 15$ . In other words,  $\rho_H^*(v_4v_5) \geq 15 - 11 = 4$ .

By Claim 2.35,  $\rho_H^*(vv_1v_4v_5) \leq 5$ . As a result,  $\rho_H^*(vv_1v_2v_3) + \rho_H^*(vv_1v_4v_5) + \rho_H^*(vw_1) \leq 2 \cdot 5 + 6 = 16$ . However, by Equation (2.3), Observation 2.37 then Claim 2.32,  $\rho_H^*(vv_1v_2v_3) + \rho_H^*(vv_1v_4v_5) + \rho_H^*(vw_1) \geq \rho_H^*(vv_1v_2v_3v_4v_5w_1) + \rho_H^*(vv_1) + \rho_H^*(v) \geq 3 \cdot 5 + 7 - 8 + 3 + 1 = 18$ .

- Suppose that  $\rho_H^*(vw_1) \geq 7$ .

If  $\rho_H^*(v_i v_j) \leq 2$  for all  $1 \leq i \neq j \leq 5$ , then  $\rho_H^*(v_1v_2) + \rho_H^*(v_3v_4) + \rho_H^*(v_5v_1) \leq 3 \cdot 2 = 6$ . Moreover, by Equation (2.3) then Observation 2.37  $\rho_H^*(v_1v_2) + \rho_H^*(v_3v_4) + \rho_H^*(v_5v_1) \geq \rho_H^*(v_1v_2v_3v_4v_5) + \rho_H^*(v_1) \geq 3 \cdot 5 - 9 + \rho_H^*(v_1) = 6 + \rho_H^*(v_1)$ . So,  $\rho_H^*(v_1) \leq 6 - 6 = 0$ . Symmetrically,  $\rho_H^*(v_i) \leq 0$  for all  $2 \leq i \leq 5$ . However, by Equation (2.3) then Observation 2.37,  $0 \geq \sum_{i=1}^5 \rho_H^*(v_i) \geq \rho_H^*(v_1v_2v_3v_4v_5) \geq 3 \cdot 5 - 9 = 6$ . So, w.l.o.g.  $\rho_H^*(v_1v_2) \geq 3$ .

By Claim 2.33,  $\rho_H^*(vw_1v_1v_2) \leq 9$ . Moreover, by Equation (2.3), Observation 2.37 then Claim 2.32,  $\rho_H^*(vw_1v_1v_2) + \rho_H^*(v_3v_4) + \rho_H^*(v_3v_5) \geq \rho_H^*(vv_1v_2v_3v_4v_5w_1) + \rho_H^*(v_3) \geq 3 \cdot 5 + 7 - 8 = 14$ . As a result,  $9 + \rho_H^*(v_3v_4) + \rho_H^*(v_3v_5) \geq \rho_H^*(vw_1v_1v_2) + \rho_H^*(v_3v_4) + \rho_H^*(v_3v_5) \geq 14$ . In other words,  $\rho_H^*(v_3v_4) + \rho_H^*(v_3v_5) \geq 14 - 9 = 5$ . So, w.l.o.g.  $\rho_H^*(v_3v_4) \geq 3$ .

By Claim 2.33,  $\rho_H^*(vw_1v_3v_4) \leq 9$ . Moreover, by Equation (2.3), Observation 2.37 then Claim 2.32,  $\rho_H^*(vw_1v_1v_2) + \rho_H^*(vw_1v_3v_4) + \rho_H^*(v_3v_5) \geq \rho_H^*(vv_1v_2v_3v_4v_5w_1) + \rho_H^*(vw_1) + \rho_H^*(v_3) \geq 3 \cdot 5 + 7 - 8 + 7 = 21$ . As a result,  $2 \cdot 9 + \rho_H^*(v_3v_5) \geq \rho_H^*(vw_1v_1v_2) + \rho_H^*(vw_1v_3v_4) + \rho_H^*(v_3v_5) \geq 21$ . In other words,  $\rho_H^*(v_3v_5) \geq 21 - 18 = 3$ .

By Claim 2.33,  $\rho_H^*(vw_1v_3v_5) \leq 9$ . As a result,  $\rho_H^*(vw_1v_1v_2) + \rho_H^*(vw_1v_3v_4) + \rho_H^*(vw_1v_3v_5) \leq 3 \cdot 9 = 27$ . However, by Equation (2.3), Observation 2.37 then Claim 2.32,  $\rho_H^*(vw_1v_1v_2) + \rho_H^*(vw_1v_3v_4) + \rho_H^*(vw_1v_3v_5) \geq \rho_H^*(vv_1v_2v_3v_4v_5w_1) + 2\rho_H^*(vw_1) + \rho_H^*(v_3) \geq 3 \cdot 5 + 7 - 8 + 2 \cdot 7 = 28$ .

### For $k = 6$ :

By Equation (2.3), Observation 2.37 then Claim 2.32,  $\sum_{i=1}^6 \rho_H^*(vv_i) \geq \rho_H^*(vv_1v_2v_3v_4v_5v_6) + 5\rho_H^*(v) \geq 3 \cdot 6 - 8 + 5 = 15$ . So, there exists  $1 \leq i \leq 6$  such that  $\rho_H^*(vv_i) \geq 3$ .

Say w.l.o.g. that  $\rho_H^*(vv_1) \geq 3$ .

If  $\rho_H^*(v_i v_j) \leq 2$  for all  $2 \leq i \neq j \leq 6$ , then  $\rho_H^*(v_2v_3) + \rho_H^*(v_4v_5) + \rho_H^*(v_6v_2) \leq 3 \cdot 2 = 6$ . Moreover, by Equation (2.3) then Observation 2.37,  $\rho_H^*(v_2v_3) + \rho_H^*(v_4v_5) + \rho_H^*(v_6v_2) \geq \rho_H^*(v_2v_3v_4v_5v_6) + \rho_H^*(v_2) \geq 3 \cdot 5 - 9 + \rho_H^*(v_2)$ . So,  $\rho_H^*(v_2) \leq 6 - 6 = 0$ . Symmetrically,  $\rho_H^*(v_i) \leq 0$  for all  $2 \leq i \leq 6$ . However, by Equation (2.3) then Observation 2.37,  $0 \geq \sum_{i=2}^6 \rho_H^*(v_i) \geq \rho_H^*(v_2v_3v_4v_5v_6) \geq 3 \cdot 5 - 9 = 6$ . So, there exist  $2 \leq i \neq j \leq 6$  such that  $\rho_H^*(v_i v_j) \geq 3$ .

Say w.l.o.g. that  $\rho_H^*(v_2v_3) \geq 3$ .

By Claim 2.35,  $\rho_H^*(vv_1v_2v_3) \leq 5$ . Moreover, by Equation (2.3) then Observation 2.37,  $\rho_H^*(vv_1v_2v_3) + \rho_H^*(v_4v_5) + \rho_H^*(v_4v_6) \geq \rho_H^*(vv_1v_2v_3v_4v_5v_6) + \rho_H^*(v_4) \geq 3 \cdot 6 - 8 = 10$ . As a result,  $\rho_H^*(v_4v_5) + \rho_H^*(v_4v_6) + 5 \geq \rho_H^*(vv_1v_2v_3) + \rho_H^*(v_4v_5) + \rho_H^*(v_4v_6) \geq 10$ . In other words,  $\rho_H^*(v_4v_5) + \rho_H^*(v_4v_6) \geq 10 - 5 = 5$ . So w.l.o.g.  $\rho_H^*(v_4v_5) \geq 3$ .

By Claim 2.35,  $\rho_H^*(vv_1v_4v_5) \leq 5$ . Moreover, by Equation (2.3) then Observation 2.37,  $\rho_H^*(vv_1v_2v_3) + \rho_H^*(vv_1v_4v_5) + \rho_H^*(v_4v_6) \geq \rho_H^*(vv_1v_2v_3v_4v_5v_6) + \rho_H^*(vv_1) + \rho_H^*(v_4) \geq 3 \cdot 6 - 8 + 3 = 13$ . As a result,  $\rho_H^*(v_4v_6) + 2 \cdot 5 \geq \rho_H^*(vv_1v_2v_3) + \rho_H^*(vv_1v_4v_5) + \rho_H^*(v_4v_6) \geq 13$ . So,  $\rho_H^*(v_4v_6) \geq 13 - 10 = 3$ .

By Claim 2.35,  $\rho_H^*(vv_1v_4v_6) \leq 5$ . As a result,  $\rho_H^*(vv_1v_2v_3) + \rho_H^*(vv_1v_4v_5) + \rho_H^*(vv_1v_4v_6) \leq 3 \cdot 5 = 15$ . However, by Equation (2.3) then Observation 2.37,  $\rho_H^*(vv_1v_2v_3) + \rho_H^*(vv_1v_4v_5) + \rho_H^*(vv_1v_4v_6) \geq \rho_H^*(vv_1v_2v_3v_4v_5v_6) + 2\rho_H^*(vv_1) + \rho_H^*(v_4) \geq 3 \cdot 6 - 8 + 2 \cdot 3 = 16$ . □

**Lemma 2.38.** Consider  $u$  a 7-vertex that is incident to a unique 3-thread  $up_1p_2p_3v$  and let  $P = \{p_1, p_2, p_3\}$ . Suppose that  $\rho_{G-P}^*(u) \leq \rho_{G-P}^*(v)$ , that  $u$  is adjacent to at least one 2-thread where the other endvertex is a  $5^-$ -vertex, and that  $u$  is adjacent to exactly one vertex  $x$  where  $d_G^*(x) \leq 12$ . Then,  $u$  has another neighbor that is neither a  $(2, 2, 0)$ -vertex nor a 2-vertex belonging to a 2-thread.

*Chứng minh.* Suppose by contradiction that  $u$  is incident to a unique 3-thread  $up_1p_2p_3v$ , to a unique neighbor  $x$  where  $d_G^*(x) \leq 12$ , to  $k$  2-threads  $uq_iq'_i v_i$  for  $1 \leq i \leq k$  where  $k \geq 1$  and  $d_G(v_1) \leq 5$ , and  $l$   $(2, 2, 0)$ -vertices  $w_j$  for  $1 \leq j \leq l$  where each  $w_j$  is incident to two 2-threads  $w_j r_j r'_j w'_j$  and  $w_j s_j s'_j w''_j$ , and finally  $k + l = 5$  (see Figure 2.15). Due to Lemma 2.15, Lemma 2.16, Lemma 2.17, and the fact that we have no multi-edges,  $u$  is distinct from  $v, x, t, v_1, \dots, v_k, w_1, \dots, w_l, w'_1, \dots, w'_l, w''_1, \dots, w''_l$ , and the endvertices of the 1-thread and 2-thread incident to  $x$  when  $x$  is a  $(2, 1, 0)$ -vertex. Similarly, for all  $1 \leq j \leq l$ ,  $w_j$  is distinct from  $w'_1, \dots, w'_l, w''_1, \dots, w''_l$ .

Let  $H = G - (\{u, p_1, p_2, p_3\} \cup \{q_i, q'_i | 1 \leq i \leq k\})$ .

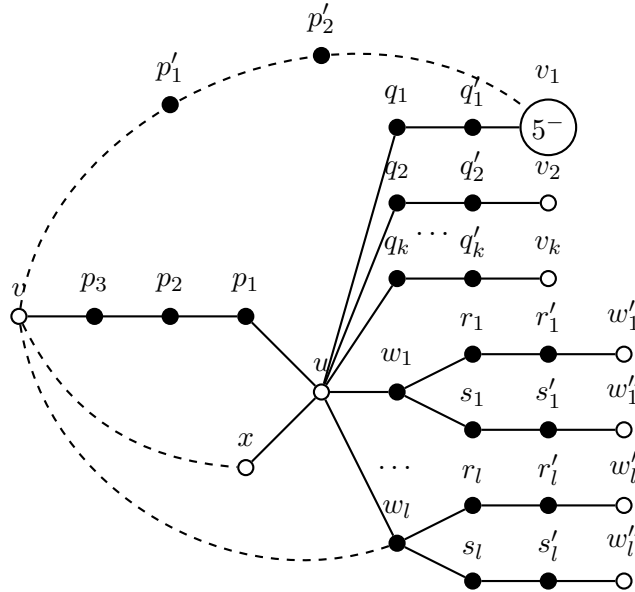

Hình 2.15: A 7-vertex that is incident to a 3-thread,  $k$  2-threads,  $l$   $(2, 2, 0)$ -vertices, and a vertex  $x$  where  $k + l = 5$  and  $d_G^*(x) \leq 12$ .

We claim that:

**Claim 2.39.** For all  $1 \leq i \leq k$  and  $1 \leq j \leq l$ ,  $\rho_H^*(vv_i) \leq 2$ ,  $\rho_H^*(vw_j) \leq 6$ , and  $\rho_H^*(vx) \leq 6$ .

If Claim 2.39 holds, then we have the following. Recall that  $\rho_{G-P}^*(u) \leq \rho_{G-P}^*(v)$  and by Lemma 2.22,  $\rho_{G-P}^*(v) \geq 1$ . As a result,  $\rho_H^*(v) \geq \rho_{G-P}^*(v) \geq 1$  by Equation (2.2). By Claim 2.39, we have  $\sum_{i=1}^k \rho_H^*(vv_i) + \sum_{j=1}^l \rho_H^*(vw_j) + \rho_H^*(vx) \leq 2k + 6l + 6 = 16 + 4l$ . However, by Equation (2.3),

then by Equation (2.4) and the fact that  $\rho_H^*(v) \geq 1$ , we also have  $\sum_{i=1}^k \rho_H^*(vv_i) + \sum_{j=1}^l \rho_H^*(vw_j) + \rho_H^*(vx) \geq \rho_H^*(vxv_1 \dots v_k w_1 \dots w_l) + 5\rho_H^*(v) \geq 14 + 4l + 5 = 19 + 4l$  which is contradiction.

Now, let us prove Claim 2.39.

First, suppose that  $\rho_H^*(vv_{i_0}) \geq 3$  for  $1 \leq i_0 \leq k$ . We add the 2-thread  $vp'_1 p'_2 v_{i_0}$  in  $H$ , let  $P' = \{p'_1, p'_2\}$  and let  $H + P'$  be the resulting graph. Since  $\rho_H^*(vv_{i_0}) \geq 3$ , by Lemma 2.7,  $\text{mad}(H + P') \leq \frac{18}{7}$ . By minimality of  $G$ , there exists a coloring  $\psi$  of  $H + P'$ . We define  $\phi$  a coloring of  $G$  as follows:

- If  $y \in V(H) \setminus (\{x\} \cup \{w_j, r_j, s_j | 1 \leq j \leq l\})$ , then  $\phi(y) = \psi(y)$ .
- Let  $\phi(q'_{i_0}) = \psi(p'_2)$  unless  $i_0 = 1$  and  $\phi(p_3) = \psi(p'_1)$ .
- We color  $q'_i$  for all  $i \neq i_0$  and  $2 \leq i \leq k$  since they all have at least one available color each.
- Note that  $d_G^*(p_2) = 4$ ,  $d_G^*(q'_1) = d_G(v_1) + 2 \leq 5 + 2 = 7$ , and  $d_G^*(r_j) = d_G^*(s_j) = 5$  for all  $1 \leq j \leq l$  so we can always color them last.
- Let  $L(y)$  be the list of available colors left for a vertex  $y$ . Observe that we have  $|L(u)| \geq 8 - (k-1) - 3 \geq 1$ ,  $|L(x)| \geq 3$  (since  $x$  sees  $d_G^*(x) - 7 \leq 5$  colored vertices),  $|L(p_1)|, |L(q_1)| \geq 7$  and  $|L(w_1)|, \dots, |L(w_l)|, |L(q_2)|, \dots, |L(q_k)| \geq 6$ . By Observation 2.26, these eight vertices are colorable unless  $|L(u) \cup L(x) \cup L(p_1) \cup L(q_1) \cup \dots \cup L(q_k) \cup L(w_1) \cup \dots \cup L(w_l)| = 7$ . However,  $p_1$  sees  $\phi(p_3) = \psi(p'_1) \notin \{\psi(p'_2), \psi(v_{i_0})\} = \{\phi(q'_{i_0}), \phi(v_{i_0})\}$  which  $q_{i_0}$  sees when  $i_0 \neq 1$ . And when  $i_0 = 1$ ,  $p_1$  sees  $\phi(p_3) = \psi(p'_1) \neq \psi(v_1) = \phi(v_1)$  which  $q_1$  sees. In both cases, we have  $|L(p_1) \cup L(q_{i_0})| \geq 8$ .

We obtain a valid coloring of  $G$  so  $\rho_H^*(vv_i) \leq 2$  for all  $1 \leq i \leq k$ .

Now, suppose that  $\rho_H^*(vz) \geq 7$  for  $z = x$  or  $z = w_{j_0}$  for  $1 \leq j_0 \leq l$ . We add the edge  $e = vz$  in  $H$  and let  $H + e$  be the resulting graph. Since  $\rho_H^*(vz) \geq 7$ , by Lemma 2.7,  $\text{mad}(H + e) \leq \frac{18}{7}$ . By minimality of  $G$ , there exists a coloring  $\psi$  of  $H + e$ . We define  $\phi$  a coloring of  $G$  as follows:

- If  $y \in V(H) \setminus (\{x\} \cup \{w_j, r_j, s_j | 1 \leq j \leq l\})$ , then  $\phi(y) = \psi(y)$ .
- Let  $\phi(p_3) = \phi(z) = \psi(z)$ .
- We color  $q'_i$  for all  $2 \leq i \leq k$  since they all have at least one available color each.
- Note that  $d_G^*(p_2) = 4$ ,  $d_G^*(q'_1) = d_G(v_1) + 2 \leq 5 + 2 = 7$ , and  $d_G^*(r_j) = d_G^*(s_j) = 5$  for all  $1 \leq j \leq l$  so we can always color them last.
- Hence, it remains to color  $N_G(u) \cup \{u\} \setminus \{z\}$ . Let  $L(y)$  be the list of available colors left for a vertex  $y$ . Observe that we have  $|L(u)| \geq 8 - (k-1) - 1 - 2 \geq 1$ ,  $|L(x)| \geq 2$  if  $z = w_{j_0}$  (since  $x$  sees  $d_G^*(x) - 6 \leq 6$  colored vertices),  $|L(q_1)| \geq 6$  and  $|L(w_1)|, \dots, |L(w_l)|, |L(q_2)|, \dots, |L(q_k)| \geq 5$ . Since there are six uncolored vertices without counting  $p_1$ , by Observation 2.26, we can color all of these vertices except  $p_1$ .
- Finally, we can color  $p_1$  since it sees eight colored vertices but it sees  $\phi(p_3) = \phi(z)$  twice.

We obtain a valid coloring of  $G$  so  $\rho_H^*(vw_j) \leq 6$  for all  $1 \leq j \leq l$  and  $\rho_H^*(vx) \leq 6$ .  $\square$

## 2.3 Discharging procedure

In this section, we will define a discharging procedure that contradicts the structural properties of  $G$  (Lemmas 2.12 to 2.38) showing that  $G$  does not exist. First, we will give a name to some special vertices in  $G$ .

**Definition 2.40** (Small, medium, and large 2-vertex). A 2-vertex  $v$  is said to be

- *large* if it is adjacent to two  $3^+$ -vertices,
- *medium* if it is adjacent to exactly one 2-vertex,
- *small* if it is adjacent to two 2-vertices.

**Definition 2.41** (Bridge vertices). We call a large 2-vertex, a 1-*thread bridge* if it has a 3-neighbor and a  $6^+$ -neighbor. We call two adjacent medium 2-vertices, a 2-*thread bridge* if one has a  $5^-$ -neighbor and the other a 7-neighbor.

**Definition 2.42** (Sponsor vertex). Due to Lemma 2.21 and Lemma 2.24, the 3-threads in  $G$  form a forest of stars. We can thus define the root of each tree in the forest as follows:

- If a tree is a star with at least two 3-threads, then the root will be the center of the star.
- If a tree has only one 3-thread, then let  $sp_1p_2p_3r$  be such a 3-thread and  $P = \{p_1, p_2, p_3\}$ . Suppose w.l.o.g. that  $\rho_{G-P}^*(r) \geq \rho_{G-P}^*(s)$ . Then,  $r$  will be the root (chosen arbitrarily if  $\rho_{G-P}^*(r) = \rho_{G-P}^*(s)$ ).

We call a vertex  $a$  *sponsor* if it is a non-root endvertex of a 3-thread. To each sponsor is assigned the small 2-vertex on the 3-thread connecting it to the root.

**Observation 2.43.** In Definition 2.42, the root of a star and the root of a matching are chosen “differently”. However, if we consider a 3-thread belonging to a star, due to Lemma 2.22 and Lemma 2.23, the center of the star will always have a higher potential than the sponsor endvertex in the subgraph where we removed the internal 2-vertices of the 3-thread.

Since we have  $\text{mad}(G) \leq \frac{18}{7}$ , we must have

$$\sum_{v \in V(G)} (7d(v) - 18) \leq 0 \quad (2.5)$$

We assign to each vertex  $v$  the charge  $\mu(v) = 7d(v) - 18$ . To prove the non-existence of  $G$ , we will redistribute the charges preserving their sum and obtaining a positive total charge, which will contradict Equation (2.5). We will do so via the following discharging rules:

**R0** (see Figure 2.16):

- Every  $3^+$ -vertex gives 2 to each adjacent large 2-neighbor, and 4 to each adjacent medium 2-neighbor.
- Every sponsor gives 4 to its assigned small 2-neighbor.
- Every  $6^+$ -vertex gives 1 to each adjacent 1-thread bridge.
- Every 7-vertex gives  $\frac{1}{2}$  to each adjacent 2-thread bridge.

**R1** (see Figure 2.17):

- Every  $6^+$ -vertex gives 4 to each adjacent (2,2,0)-neighbor.
- Every  $5^+$ -vertex gives  $\frac{5}{2}$  to each adjacent (2,1,0)-neighbor.
- Every  $4^+$ -vertex gives 1 to each adjacent (1,1,0)-neighbor and  $\frac{1}{2}$  to each adjacent (2,0,0)-neighbor.
- Every 1-thread bridge gives 1 to its 3-neighbor.

**R2** (see Figure 2.18):

- (i) Every  $5^+$ -vertex gives  $\frac{1}{2}$  to each  $(2,2,2,0)$ -neighbor.
- (ii) Every 2-thread bridge gives  $\frac{1}{2}$  to its  $5^-$ -neighbor.

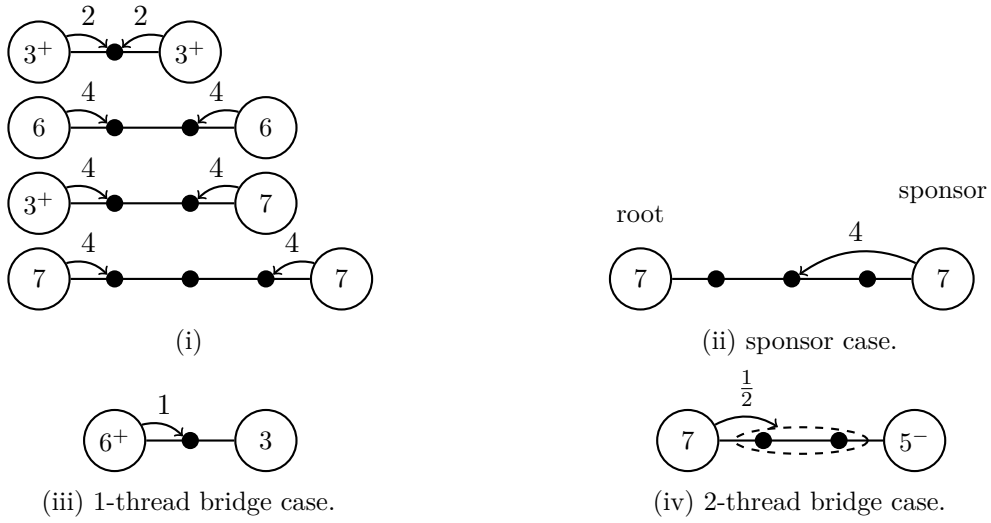

Hình 2.16: **R0**.

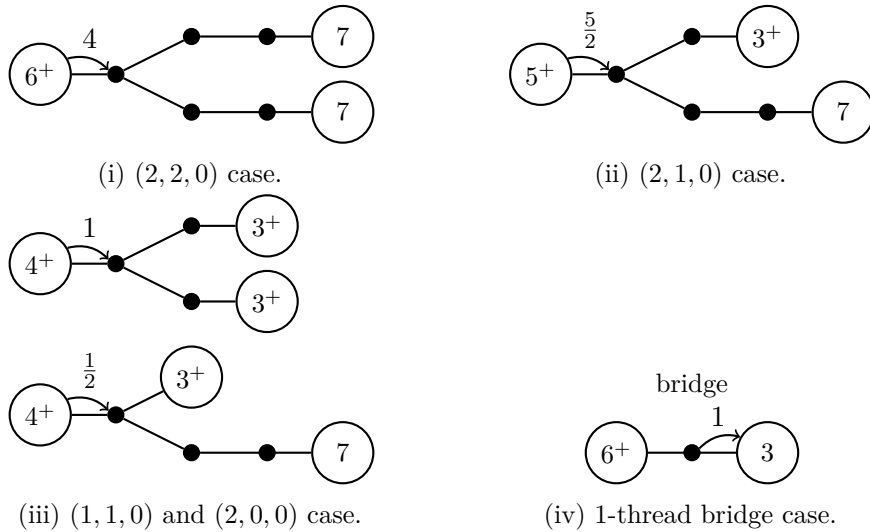

Hình 2.17: **R1**.

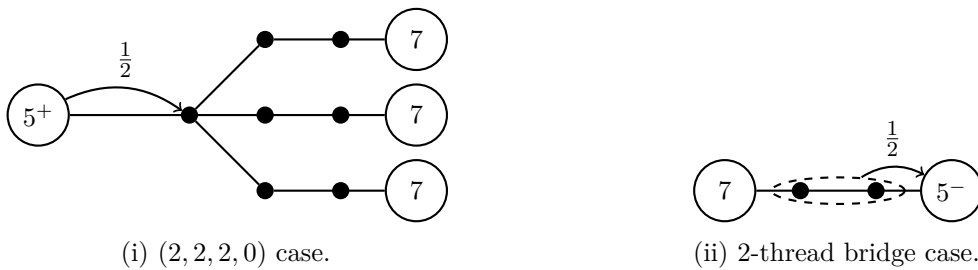

Hình 2.18: **R2**.

In the following two subsections, we will first prove that every vertex ends up with a non-negative charge after the discharging procedure. Thus, by Equation (2.5), every vertex must have exactly charge 0 which will be proven to be impossible.

### Verifying that charges on each vertex are non-negative

Let  $\mu^*$  be the assigned charges after the discharging procedure. In what follows, we prove that:

$$\forall v \in V(G), \mu^*(v) \geq 0.$$

**Case 1:**  $d(v) = 2$ .

We have  $\mu(v) = -4$ . Vertex  $v$  receives 4 by **R0**(i) and **R**(0ii). Now if  $v$  belongs to a 1-thread (resp. 2-thread) bridge, then it also gives 1 (resp.  $\frac{1}{2}$ ) to a 3-vertex (resp.  $5^-$ -vertex) by **R1**(iv) (resp. **R2**(ii)), but it also receives 1 (resp.  $\frac{1}{2}$ ) from **R0**(iii) (resp. **R0**(iv)). In all cases,  $\mu^*(v) = 0$ .

**Case 2:**  $d(v) = 3$ .

Vertex  $v$  only gives away charges by **R0**(i): 4 (resp. 2) in the case of a 2-thread (resp. in the case of a 1-thread) and receives charges by **R1** and **R2**(ii). Recall  $\mu(v) = 3$ . By Lemma 2.18,  $v$  is not a  $(2, 1^+, 1^+)$ -vertex. Let us examine all possible configurations for  $v$ .

- Suppose that  $v$  is a  $(2, 2, 0)$ -vertex. Let  $v_1, v_2$ , and  $u$  be the two 2-neighbors and  $3^+$ -neighbor of  $v$  respectively. Since  $v_1$  and  $v_2$  satisfy  $d^*(v_1) = d^*(v_2) = 5 \leq \Delta$ , by Observation 2.13,  $d^*(v) \geq 10$  and  $d^*(v) = d(u) + 4$ , so  $d(u) \geq 6$ . By **R1**(i),  $v$  receives 4 from  $u$ . Due to Lemma 2.16 and by **R2**(ii),  $v$  also receives charge  $\frac{1}{2}$  twice from incident 2-thread bridges. In total, we have

$$\mu^*(v) \geq 3 - 4 \cdot 2 + 4 + 2 \cdot \frac{1}{2} = 0.$$

- Suppose that  $v$  is a  $(2, 1, 0)$ -vertex. Let  $v_1, v_2$ , and  $u$  be the two 2-neighbors (where  $v_1$  belongs to the 1-thread and  $v_2$  belongs to the 2-thread) and the  $3^+$ -neighbor of  $v$  respectively. As previously, due to Lemma 2.16 and by **R2**(ii),  $v$  receives  $\frac{1}{2}$  from the incident 2-thread bridge. Vertex  $v_2$  has  $d^*(v_2) = 5 \leq \Delta$ . By Observation 2.13,  $d^*(v) \geq 9$  and  $d^*(v) = d(u) + 4$ , so  $d(u) \geq 5$ . Hence,  $v$  receives  $\frac{5}{2}$  from  $u$  by **R1**(ii). So,

$$\mu^*(v) \geq 3 - 4 - 2 + \frac{1}{2} + \frac{5}{2} = 0.$$

- Suppose that  $v$  is a  $(2, 0, 0)$ -vertex. Let  $u_1, u_2$ , and  $v_1$  be the two  $3^+$ -neighbors and the 2-neighbor of  $v$  respectively. Since  $d^*(v_1) = 5 \leq \Delta$ . By Observation 2.13,  $d^*(v) \geq 9$  and  $d^*(v) = d(u_1) + d(u_2) + 2$ , so  $d(u_1) + d(u_2) \geq 7$ . We can assume w.l.o.g. that  $d(u_1) \geq 4$ , thus  $v$  receives  $\frac{1}{2}$  from  $u_1$  by **R1**(iii). Due to Lemma 2.16 and by **R2**(ii),  $v$  also receives  $\frac{1}{2}$  from the incident 2-thread bridge. So,

$$\mu^*(v) \geq 3 - 4 + \frac{1}{2} + \frac{1}{2} = 0.$$

- Suppose that  $v$  is a  $(1, 1, 1)$ -vertex. Let  $vv'v''$  be a 1-thread incident to  $v$ . We have  $d^*(v) = 6 \leq \Delta$ . It follows that  $d^*(v') \geq 9$  by Observation 2.13 and as  $d^*(v') = d(v'') + 3$ , we have  $d(v'') \geq 6$ , meaning that  $v'$  is a 1-thread bridge. Thus, vertex  $v$  gives 2 to each 2-neighbor by **R0**(i) and receives 1 from each 2-neighbor by **R1**(iv). We have

$$\mu^*(v) \geq 3 - 3 \cdot 2 + 3 \cdot 1 = 0.$$

- Suppose that  $v$  is a  $(1, 1, 0)$ -vertex. Let  $vv_1w_1$  and  $vv_2w_2$  be the two 1-threads incident to  $v$  and let  $u$  be the  $3^+$ -neighbor of  $v$ .

If  $d(u) = 3$ , then  $d^*(v) = 7 \leq \Delta$ . By Observation 2.13,  $d^*(v_1) \geq 9$ . As  $d^*(v_1) = d(w_1) + 3$ , we have  $d(w_1) \geq 6$  meaning that  $v$  receives 1 from  $v_1$  by **R1(iv)** (and from  $v_2$  by symmetry). Hence,

$$\mu^*(v) \geq 3 - 2 \cdot 2 + 2 \cdot 1 = 1.$$

If  $d(u) \geq 4$ , then  $v$  receives 1 from  $u$  by **R1(iii)**. And so,

$$\mu^*(v) \geq 3 - 2 \cdot 2 + 1 = 0.$$

- Suppose that  $v$  is a  $(1^-, 0, 0)$ -vertex, then at worst, we have

$$\mu^*(v) \geq 3 - 2 = 1.$$

**Case 3:**  $d(v) = 4$ .

Vertex  $v$  may give 4 (resp. 2, 1,  $\frac{1}{2}$ ) by **R0(i)** in the case of a 2-thread (resp. **R0(i)** in the case of a 1-thread, **R1(iii)** in the case of a  $(1, 1, 0)$ -neighbor, **R1(iii)** in the case of a  $(2, 0, 0)$ -neighbor). Recall  $\mu(v) = 10$ .

By Lemma 2.18,  $v$  is not a  $(2, 1^+, 1^+, 1^+)$ -vertex. Hence,  $v$  is incident to at most three 2-threads:

- If  $v$  is a  $(2, 2, 2, 0)$ , then let  $v_1, v_2, v_3$  be the 2-neighbors along the three 2-threads and  $u$  the last neighbor. Since  $d(v_i) = 6 \leq \Delta$  for all  $1 \leq i \leq 3$ , by Observation 2.13,  $d^*(v) \geq 11$ . Moreover,  $d^*(v) = d(u) + 6$  so  $d(u) \geq 5$ . By **R2(i)**,  $v$  receives  $\frac{1}{2}$  from  $u$ . Due to Lemma 2.16 and by **R2(ii)**,  $v$  also receives  $\frac{1}{2}$  from each incident 2-thread bridge. So,

$$\mu^*(v) \geq 10 - 3 \cdot 4 + \frac{1}{2} + 3 \cdot \frac{1}{2} = 0.$$

- If  $v$  is a  $(2, 2, 1^-, 0)$ , then let  $v_1, v_2$  be the 2-neighbors along the two 2-threads and  $u_1, u_2$  the other two neighbors. Since  $d(v_1) = d(v_2) = 6 \leq \Delta$ , by Observation 2.13,  $d^*(v) \geq 10$ . Moreover,  $d^*(v) = d(u_1) + d(u_2) + 4$  so  $d(u_1) + d(u_2) \geq 6$ . Due to Lemma 2.16 and by **R2(ii)**,  $v$  also receives  $\frac{1}{2}$  from each incident 2-thread bridge.

If  $d(u_1) = 2$ , then  $d(u_2) \geq 4$ . So,

$$\mu^*(v) \geq 10 - 2 \cdot 4 - 2 + 2 \cdot \frac{1}{2} = 1.$$

If  $d(u_1) \geq 3$  and  $d(u_2) \geq 3$ , then at worst,

$$\mu^*(v) \geq 10 - 2 \cdot 4 - 2 \cdot 1 + 2 \cdot \frac{1}{2} = 1.$$

- If  $v$  is a  $(2, 1^-, 1^-, 0)$ , then at worst

$$\mu^*(v) \geq 10 - 4 - 2 \cdot 2 - 1 = 1.$$

- If  $v$  is a  $(1^-, 1^-, 1^-, 1^-)$ , then at worst

$$\mu^*(v) \geq 10 - 4 \cdot 2 = 2.$$

**Case 4:**  $d(v) = 5$ .

Vertex  $v$  may give 4 (resp.  $2, \frac{5}{2}, 1, \frac{1}{2}, \frac{1}{2}$ ) by **R0(i)** in the case of a 2-thread (resp. **R0(i)** in the case of a 1-thread, **R1(ii)**, **R1(iii)** in the case of a  $(1,1,0)$ -neighbor, **R1(iii)** in the case of a  $(2,0,0)$ -neighbor, **R2(i)**). Recall  $\mu(v) = 17$ .

If  $v$  is a  $(2, 2, 2, 2, 0^+)$ , then let  $v_1, v_2, v_3, v_4$  be the 2-neighbors along the four 2-threads and  $u$  the last neighbor. Since  $d(v_i) = 7 \leq \Delta$  for all  $1 \leq i \leq 4$ , by Observation 2.13,  $d^*(v) \geq 12$ . Moreover,  $d^*(v) = d(u) + 8$  so  $d(u) \geq 4$ . Finally,

$$\mu^*(v) \geq 17 - 4 \cdot 4 - \frac{1}{2} = \frac{1}{2}.$$

If  $v$  is a  $(2, 2^-, 2^-, 1^-, 1^-)$ , then  $v$  may give at most  $4, 4, 4, \frac{5}{2}, \frac{5}{2}$  along incident edges ; so

$$\mu^*(v) \geq 17 - 3 \cdot 4 - 2 \cdot \frac{5}{2} = 0.$$

If  $v$  is a  $(1^-, 1^-, 1^-, 1^-, 1^-)$ , then  $v$  may give at most  $\frac{5}{2}$  along each incident edge ; so

$$\mu^*(v) \geq 17 - 5 \cdot \frac{5}{2} = \frac{9}{2}.$$

**Case 5:**  $d(v) = 6$ .

Observe that  $v$  never gives away more than 4 along any edge. Indeed, it may give 4 (resp.  $3, 4, \frac{5}{2}, 1, \frac{1}{2}, \frac{1}{2}$ ) by **R0(i)** in the case of a 2-thread (resp. **R0(i)** and **R0(iii)** in the case of a 1-thread, **R1(i)**, **R1(ii)**, **R1(iii)** in the case of a  $(1,1,0)$ -neighbor, **R1(iii)** in the case of a  $(2,0,0)$ -neighbor, **R2(i)**). Recall that  $\mu(v) = 24$ . So, at worst we have

$$\mu^*(v) \geq 24 - 6 \cdot 4 = 0.$$

**Case 6:**  $d(v) = 7$ .

Observe that every rule except for **R1(iv)** and **R2(ii)** may apply to  $v$  and recall that  $\mu(v) = 31$ . Observe that, when  $v$  is not a sponsor, the largest amount of charge that  $v$  can send away along an edge is  $\frac{9}{2}$  which only happens in the case of a 2-thread bridge by **R0(i)** and **R0(iv)**.

- Suppose that  $v$  is not incident to a 3-thread. The case where  $v$  is incident to seven 2-thread bridges is impossible due to Lemma 2.19. It follows that,

$$\mu^*(v) \geq 31 - 6 \cdot \frac{9}{2} - 4 = 0.$$

- Suppose that  $v$  is incident to a 3-thread, then:

- Suppose that  $v$  is not a sponsor. Then,  $v$  gives only 4 to a medium 2-neighbor on a 3-thread and nothing to the small 2-neighbor at distance 2. Due to Lemma 2.19,  $v$  cannot be also incident to six 2-thread bridges. So, at worst, we have

$$\mu^*(v) \geq 31 - 4 - 5 \cdot \frac{9}{2} - 4 = \frac{1}{2}.$$

- Suppose that  $v$  is a sponsor. Then, by definition,  $v$  is incident to a unique 3-thread. So,  $v$  gives 4 to its medium 2-neighbor and 4 to its small 2-neighbor at distance 2, which is a total of 8 that  $v$  sends away along the 3-thread.

Suppose that  $v$  is not incident to any 2-thread bridge. Observe that  $v$  gives 4 to a neighbor only by **R0(i)** in the case of a 2-thread and **R1(i)** in the case of a  $(2, 2, 0)$ -neighbor. By Observation 2.43 and Lemma 2.31, a sponsor has a neighbor different from a  $(2, 2, 0)$ -vertex, a 2-vertex on a 2-thread and a 2-vertex on a 3-thread. In other



words,  $v$  gives less than 4 to a vertex, which is at most 3 (by **R0(i)** and **R0(iii)** in the case of a 1-thread bridge and less than 3 in the other cases). Thus, at worst, we have

$$\mu^*(v) \geq 31 - 8 - 3 - 5 \cdot 4 = 0.$$

Suppose that  $v$  is incident to a 2-thread bridge. Vertex  $v$  is incident to at most two 2-thread bridges due to Observation 2.43 and Lemma 2.29 ( $v$  gives away  $\frac{9}{2}$  along each of these 2-thread bridges). Due to Observation 2.43 and Lemma 2.31, at least one of  $v$ 's neighbors is not a 2-vertex belonging to a 2-thread or a 3-thread, nor a  $(2, 2, 0)$ -vertex. So  $v$  gives less than 4 to at least one neighbor.

If  $v$  gives less than 4 to two neighbors, then we have

$$\mu^*(v) \geq 31 - 8 - 2 \cdot \frac{9}{2} - 2 \cdot 3 - 2 \cdot 4 = 0.$$

So  $v$  gives less than 4 to exactly one neighbor. If that amount is at most 2, then at worst, we have

$$\mu^*(v) \geq 31 - 8 - 2 \cdot \frac{9}{2} - 2 - 3 \cdot 4 = 0.$$

So that amount must be more than 2, so it must be  $\frac{5}{2}$  by **R1(ii)** in the case of a  $(2, 1, 0)$ -neighbor, or 3 by **R0(i)** and **R0(iii)** in the case of a 1-thread bridge. Both of these cases cannot occur by Lemma 2.38.

### Proving the non-existence of $G$ .

In the previous subsection, we have proven that every vertex has a non-negative amount of charge after the discharging procedure. Since the discharging rules preserve the total amount of charge and the total is non-positive by Equation (2.5), every vertex must have exactly charge 0. Consequently, we have the following:

- There are no 3-threads since the endvertex of a 3-thread that is not a sponsor always has at least charge  $\frac{1}{2}$  due to **Case 6**.
- There are no 7-vertices. Indeed, since there are no 3-threads, a 7-vertex  $v$ , with final charge 0, must be incident to six 2-thread bridges (where  $v$  gives away  $\frac{9}{2}$  along each thread) and be adjacent to a  $(2, 2, 0)$ -vertex or a 2-vertex belonging to a 2-thread (where  $v$  gives 4 in each case). The former is impossible due to Lemma 2.19. In the latter, the endvertex  $u$  of the 2-thread, which is not a bridge, must be a 7-vertex by Lemma 2.19. Since  $u$  also has charge 0,  $u$  must also be incident to six 2-thread bridges, which is not possible due to Lemma 2.27.
- There are no 4-vertices or 5-vertices. Indeed, since there are no 7-vertices, due to Lemma 2.16, a 4-vertex or 5-vertex cannot be incident to a 2-thread. So by **Case 3** and **Case 4**, they always have at least charge 2.
- There are no 6-vertices. Indeed, by **Case 5**, a 6-vertex, with final charge 0, must give 4 to each of its neighbors. In other words, its neighbors must be  $(2, 2, 0)$ -vertices (which is impossible by Lemma 2.16 and the fact that we have no 7-vertices) or 2-vertices belonging to 2-threads (where the other endvertices are 6-vertices for the same reason). However, by Lemma 2.20, we cannot have a 6-vertex that is incident to six 2-threads with 6-endvertices.
- There are no 3-vertices. Indeed, if we take a closer look at **Case 2**, we can observe the following:
  - There are no 3-vertices incident to a 2-thread by Lemma 2.16 and the fact that we have no 7-vertices.

- There are no  $(1, 1, 1)$ -vertices since the other endvertices of the 1-threads are  $6^+$ -vertices and we have no  $6^+$ -vertices.
- There are no  $(1, 1, 0)$ -vertices. Indeed, the  $3^+$ -neighbor must be a 3-vertex since there are no  $4^+$ -vertices, and as a result, the  $(1, 1, 0)$ -vertex has at least charge 1 left.
- There are no  $(1^-, 0, 0)$ -vertices since they always have at least charge 1 left.

Finally,  $G$  has only 2-vertices so  $G$  must be a cycle which is 2-distance 8-colorable. That completes the proof of Theorem 2.6.

## Chương 3

# Computer assisted discharging procedures

One of the limits of the discharging method is achieved when one needs to consider a large amount of case distinctions in a proof. This happens essentially for two main reasons: the coloring of a configuration involves a complicated case analysis, or the set of reducible configurations needed in the proof is too large. Using computer assistance seems to be the most natural way to overcome this hurdle.

The most famous example of computer assistance in the discharging procedure is the proof of the Four Color Theorem. Showing that a configuration is reducible is very dependent on the type of coloring. On the other hand, generating a set of unavoidable configurations is more dependent on the class of graphs. In this chapter, we present an algorithm that, given a particular set of discharging rules, generates all to-be-reduced configurations for planar graphs. We implemented this algorithm and applied it to show the following theorem. The source code can be found at <https://gite.lirmm.fr/discharging/planar-graphs>.

**Theorem 3.1.** Let  $G$  be a planar subcubic graph with girth  $g \geq 8$ . Then  $\chi^2(G) \leq 6$ .

We wish to highlight that, even though a large part of this chapter deals with the technicality of this particular problem, our algorithm is independent from the coloring problem. Indeed, we propose an efficient encoding of local structures of planar graphs with respect to a discharging procedure. Using this encoding we show how to filter out the “problematic” configurations in order to obtain a proof. We first show how to use these ideas in the case of 2-distance coloring (see Section 3.3.2) and then give the general idea of how to use our algorithm and computer program for other problems (see Section 3.4).

The main idea of the proof is to use a charge distribution that concentrates the charges on vertices and the only faces with negative charge are of length 8. With the assistance of a computer program, we list each possible close neighbourhoods around a face of length 8. For each of these neighborhoods, our algorithm shows that either it contains a reducible configuration or it can get enough charge from its incident vertices (Section 3.3.2).

In this chapter, we always consider a 2-distance 6-coloring. Thus, for a vertex  $v$ , we denote  $L(v)$  the set of available colors from  $\{a, b, c, d, e, f\}$ . We also use Hall’s Theorem (Observation 2.26) very often.

### 3.1 Useful observations and lemmas

---

Before diving into the proof of Theorem 3.1, we show some colorable and non-colorable configurations, that is graphs together with lists of available colors for each vertex. These observations will be extensively used in Section 3.2.

For this section, a vertex  $v$  will be labeled with its name. Additionally, when a lower bound on  $|L(v)|$  is known, it will be depicted on the figure. For example, the graph depicted in Figure 3.1i is a path  $v_1v_2v_3v_4$  with the following size of lists of available colors:  $|L(v_1)| \geq 2$ ,  $|L(v_2)| \geq 3$ ,  $|L(v_3)| \geq 2$ ,  $|L(v_4)| \geq 2$ .

**Lemma 3.2.** The graphs depicted in Figures 3.1i to 3.1xv are 2-distance colorable.

*Chứng minh.* In the proofs of this section, whenever the size of a list  $|L(v)| \geq k$  we assume that  $|L(v)| = k$  by arbitrarily removing the extra colors from the list. One can easily observe that these proofs will hold for the case when  $|L(v)| > k$ .

We will give the proofs for each figure in order:

*Proof of Figure 3.1i.* If  $v_1$  and  $v_4$  can be colored with the same color, then finish by coloring  $v_3, v_2$  in this order. Otherwise, since  $L(v_1) \cap L(v_4) = \emptyset$  we have  $|L(v_1) \cup L(v_4)| \geq 4$ , so one can apply Hall's Theorem. □

*Proof of Figure 3.1ii.* If  $L(v_4) \neq L(v_5)$ , then color  $v_5$  with  $x \notin L(v_4)$  and get Figure 3.1i, so we are done. Otherwise, color  $v_3$  with a color  $y \notin L(v_5) \cup L(v_4)$ . Then color  $v_1, v_2, v_4, v_5$ , in this order. □

*Proof of Figure 3.1iii.* If  $L(v_1) \neq L(v_3)$ , then color  $v_1$  with  $x \notin L(v_3)$  and get Figure 3.1ii. Otherwise, color  $v_2$  with a color  $y \notin L(v_3) \cup L(v_1)$ , then color  $v_3, v_4, v_5, v_6$  using Figure 3.1i and finish by coloring vertex  $v_1$ . □

*Proof of Figure 3.1iv.* Observe that  $L(v_3) = L(v_4)$  because if not we color  $v_4$  with  $x \notin L(v_3)$  and we get Figure 3.1i. Thus color  $v'_3$  with  $y \notin L(v_3)$  and get Figure 3.1i again. □

*Proof of Figure 3.1v.* If  $L(v_2) \neq L(v_4)$ , then one could color  $v_4$  with  $x \notin L(v_2)$ , then by Figure 3.1i we are done. Otherwise, since  $|L(v'_3)| \geq 3$ , color  $v'_3$  with a color  $y \notin L(v_4) \cup L(v_2)$ . Then again by Figure 3.1i we are done. □

*Proof of Figure 3.1vi.* Observe that there exists  $x \in L(v'_3) \setminus L(v_2)$ . Thus  $x \in L(v_4)$  as otherwise one could color  $v'_3$  with  $x$  and get Figure 3.1ii. Hence  $x \in L(v_5)$ , as otherwise one could color  $v_4$  with  $x$ , color vertices  $v_1, v_2, v_3, v'_3$  by Figure 3.1i and finish by coloring vertex  $v_5$ . Therefore, we color  $v'_3$  and  $v_5$  with  $x$  and we get Figure 3.1i. □

*Proof of Figure 3.1vii.* First observe that  $L(v_1) \subset L(v'_2)$ . Otherwise, we define the following coloring  $\phi$ . By coloring  $v_3$  with  $x \notin L(v_1)$  and coloring  $v_4, v'_3$  and  $v_2$  in this order, if we cannot finish the coloring, then both  $v_1$  and  $v'_2$  must have the same remaining color  $y$ . Moreover, it means  $L(v_1) = \{y, \phi(v_2)\} \subset L(v'_2) = \{y, \phi(v_2), x\}$  while  $L(v_1) \not\subset L(v'_2)$ .

Now, suppose  $L(v_3) \neq L(v'_2)$  and color vertex  $v_3$  with  $y \notin L(v'_2) \supset L(v_1)$ . Then color  $v_4, v'_3, v_2, v_1, v'_2$  in this order. Therefore  $L(v_3) = L(v'_2) \supset L(v_1)$  and we color  $v_2$  with  $z \notin L(v_3)$  and finish by coloring  $v_4, v'_3, v_3, v_1, v'_2$  in this order. □

*Proof of Figure 3.1viii.* First note that  $L(v_4) = L(v_5)$  as otherwise by coloring  $v_5$  with  $x \notin L(v_4)$  we get Figure 3.1vii. If  $L(v_5) \subset L(v'_3)$ , then we color vertex  $v_3$  with  $y \notin L(v'_3)$  and  $v_1, v'_2, v_2, v_4, v_5, v'_3$  in this order. We conclude that  $|L(v'_3) \setminus L(v_5)| \geq 2$ . Thus by replacing  $L(v'_3)$  with  $L(v'_3) \setminus L(v_5)$  and  $L(v_3)$  with  $L(v_3) \setminus L(v_5)$ , we can color vertices  $v_1, v_2, v'_2, v_3, v'_3$  by Figure 3.1v and finish by coloring vertices  $v_4$  and  $v_5$ . □

*Proof of Figure 3.1ix.* Suppose  $L(v_2) \neq L(v'_3)$ . Then restrict the list of colors of  $v_3$  to  $L(v_3) \setminus L(v_1)$ , color vertices  $v_3, v_4, v'_4, v_5$ , and  $v_6$  by Figure 3.1v and finish by coloring  $v'_3, v_2$ , and  $v_1$  in this order. Therefore, we have  $L(v_2) = L(v'_3)$ . Now, if  $L(v_5) \neq L(v_6)$ , then we color vertex  $v_4$  with  $x \notin L(v'_3)$ , color  $v_5$  and  $v_6$  (because theirs lists are different) and finish by coloring  $v'_4, v_3, v_1, v_2$ , and  $v'_3$  in this order. Thus we have  $L(v_5) = L(v_6)$ . Color vertex  $v_3$  with  $y \notin L(v_2) = L(v'_3)$ . If  $y \in L(v_6)$ , then color vertex  $v_6$  with  $y$  and finish by coloring  $v_5, v'_4, v_4, v_1, v_2, v'_3$  in this order. If  $y \notin L(v_6) = L(v_5)$ , then color  $v'_4, v_4, v_5, v_6$  by Figure 3.1i and finish by coloring  $v_1, v_2, v'_3$  in this order. □

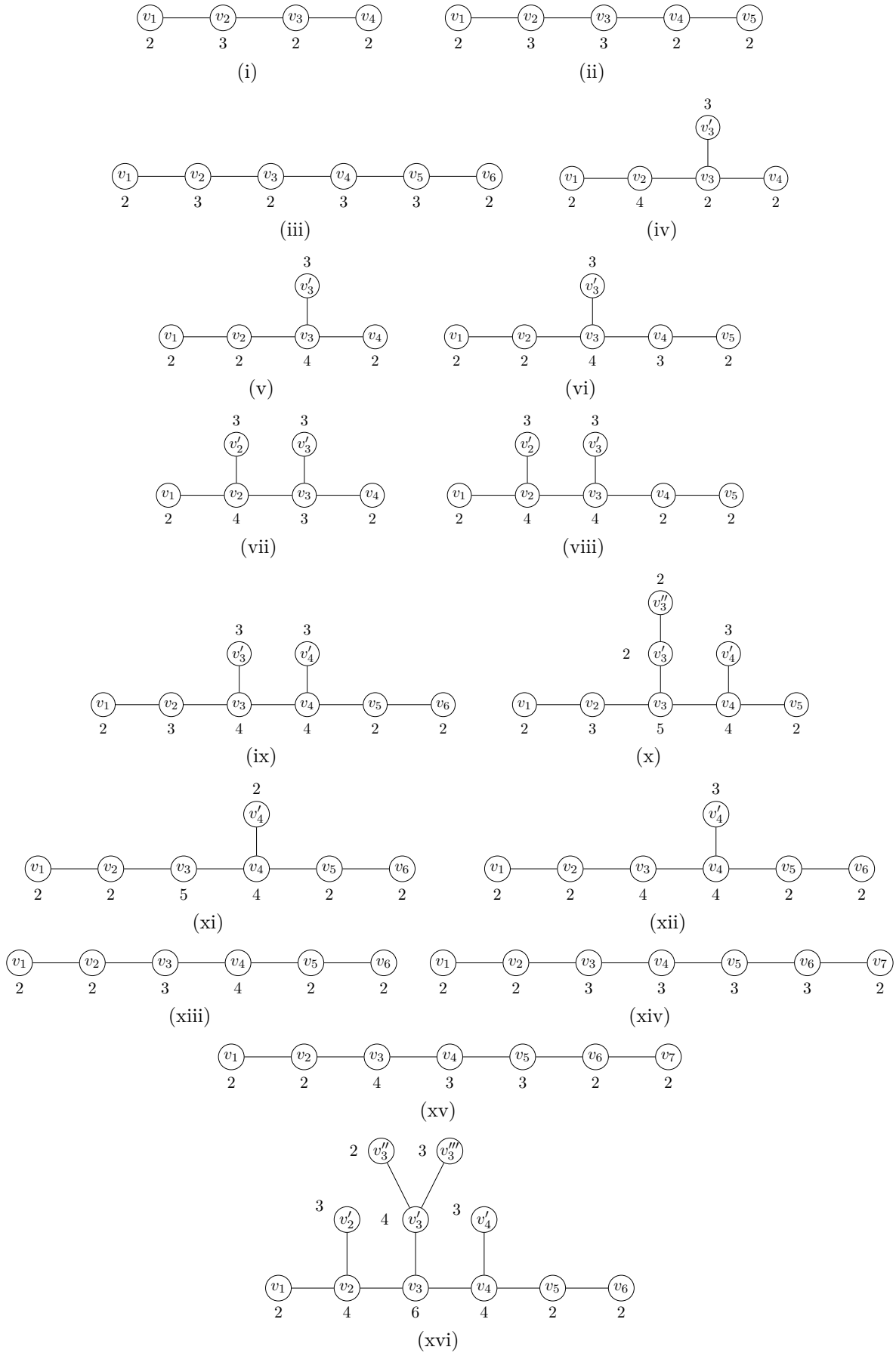

Hình 3.1: Useful 2-distance colorable configurations (Lemma 3.2).

*Proof of Figure 3.1x.* If  $L(v_1) \not\subset L(v_2)$ , then by coloring  $v_1$  with  $y \notin L(v_2)$  we get Figure 3.1viii. Hence, we have w.l.o.g.  $L(v_1) = \{a, b\}$  and  $L(v_2) = \{a, b, c\}$ .

If  $L(v_2) \not\subset L(v_3)$ , then we restrict  $L(v_3)$  to  $L(v_3) \setminus L(v_2)$ . Observe that  $|L(v_3) \setminus L(v_2)| \geq 3$ . Now, we look at the two following cases:

- When  $L(v'_3) = L(v''_3)$ , we color  $v_3$  with  $x \notin L(v'_3)$  and then  $v_5, v'_4, v_4, v'_3, v''_3, v_2, v_1$  in this order.
- When  $L(v'_3) \neq L(v''_3)$ , we color  $v''_3$  with  $y \notin L(v'_3)$  and we obtain Figure 3.1v. We color  $v_2$  and  $v_1$  last.

So,  $L(v_2) \subset L(v_3)$ . We can thus assume w.l.o.g. that  $L(v_3) = \{a, b, c, d, e\}$ .

If  $d \notin L(v'_3) \cup L(v''_3)$ , then we color  $v_3$  with  $d$ , then  $v_5, v'_4, v_4, v'_3, v''_3, v_2, v_1$  in this order. The same holds for  $e$ . So, we must have  $\{d, e\} \subseteq L(v'_3) \cup L(v''_3)$ .

If  $L(v'_3) = L(v''_3)$ , then due to the previous observation,  $L(v'_3) = L(v''_3) = \{d, e\}$ . In this case, we color  $v_3$  with  $c$ , then  $v_5, v'_4, v_4, v'_3, v''_3, v_2, v_1$  in this order. As a result,  $L(v'_3) \neq L(v''_3)$ .

If  $L(v'_3) \subset L(v_2)$ , then we must have  $L(v''_3) = \{d, e\}$ . We then color  $v_3$  with  $d$ , then  $v''_3, v_5, v'_4, v_4, v'_3, v_2, v_1$  in this order.

If  $L(v'_3) \not\subset L(v_3)$ , then  $f \in L(v'_3)$ . We color  $v'_3$  with  $f$ , then  $v''_3$  and  $v_5$ . We can then finish coloring  $v_1, v_2, v_3, v_4, v'_4$  by Figure 3.1ii. We can thus assume w.l.o.g. that  $d \in L(v'_3)$ .

If  $c \notin L(v'_3)$ , then we color  $v_2$  with  $c$ ,  $v_4$  with  $x \in L(v_4) \setminus L(v'_3)$ , and  $v_5, v'_4, v_3, v_1$  in this order. We can finish by coloring  $v'_3$  and  $v''_3$  since  $L(v'_3) \neq L(v''_3)$ . So,  $c \in L(v'_3)$ .

To summarize the previous observations, we have  $L(v_1) = \{a, b\}$ ,  $L(v_2) = \{a, b, c\}$ ,  $L(v_3) = \{a, b, c, d, e\}$ ,  $L(v'_3) = \{c, d\}$  and  $e \in L(v''_3)$ . We color  $v''_3$  with  $e$ . We restrict  $L(v_3)$  to  $\{c, d\}$ . We color  $v'_3, v_3, v_4, v'_4, v_5$  by Figure 3.1v. Finally, we finish by coloring  $v_2$  and  $v_1$  in this order.  $\square$

*Proof of Figure 3.1xi.* If  $L(v_2) \neq L(v_1)$ , then color  $v_2$  with  $x \notin L(v_1)$ , color vertices  $v'_4, v_4, v_5, v_6$  by Figure 3.1i and finish with  $v_3$  and  $v_1$ . If  $L(v_2) = L(v_1)$ , then by restricting the list of colors of  $v_3$  to  $L(v_3) \setminus L(v_2)$ , we color vertices  $v_3, v_4, v'_4, v_5, v_6$  by Figure 3.1v and finish with  $v_2$  and  $v_1$ .  $\square$

*Proof of Figure 3.1xii.* Observe that  $L(v_1) = L(v_2)$  since otherwise one could color  $v_1$  with  $x \notin L(v_2)$  and get Figure 3.1vi. Therefore, we restrict the list of colors of  $v_3$  to  $L(v_3) \setminus L(v_2)$ . We color then  $v_3, v_4, v'_4, v_5, v_6$  by Figure 3.1v and finish with  $v_2$  and  $v_1$ .  $\square$

*Proof of Figure 3.1xiii.* If  $L(v_5) \neq L(v_6)$ , then by coloring  $v_6$  with  $x \notin L(v_5)$ , one could finish by Figure 3.1ii. Thus  $L(v_5) = L(v_6)$  and we restrict the list of colors of  $v_4$  to  $L(v_4) \setminus L(v_5)$ , color vertices  $v_1, v_2, v_3, v_4$  by Figure 3.1i and finish with  $v_5$  and  $v_6$ .  $\square$

*Proof of Figure 3.1xiv.* Observe that  $L(v_1) = L(v_2)$  as otherwise by coloring  $v_2$  with  $x \notin L(v_1)$ , one could color  $v_3, v_4, v_5, v_6, v_7$  by Figure 3.1ii and finish by coloring  $v_1$ . Therefore, color  $v_3$  with  $y \notin L(v_2) \cup L(v_1)$ , color  $v_4, v_5, v_6, v_7$  by Figure 3.1i and finish by coloring  $v_2, v_1$  in this order.  $\square$

*Proof of Figure 3.1xv.* Note that  $L(v_6) = L(v_7)$  as otherwise by coloring  $v_7$  with  $x \notin L(v_6)$  one could finish by Figure 3.1xiii. Hence color  $v_5$  with  $y \notin L(v_7) \cup L(v_6)$ , then color  $v_1, v_2, v_3, v_4$  by Figure 3.1i and finish with  $v_6, v_7$ .  $\square$

*Proof of Figure 3.1xvi.* If it is possible to color  $v_1$  and  $v_5$  with the same color, then after coloring  $v_6$ , we get Figure 3.1x. Hence  $L(v_1) \cap L(v_5) = \emptyset$ . If it is possible to color  $v_5$  and  $v'_2$  with a common color, then after coloring  $v_6$ , we get again Figure 3.1x. Hence  $L(v'_2) \cap L(v_5) = \emptyset$ . Symmetrically, we have  $L(v''_3) \cap L(v_5) = \emptyset$  and  $L(v'''_3) \cap L(v_5) = \emptyset$ .

Now, since we are considering a 6-coloring, we restrict the list of colors of  $v_3$  to  $L(v_3) = L(v_5)$  and color vertices  $v_3, v_4, v'_4, v_5, v_6$  by Figure 3.1v. We finish by coloring the remaining vertices in the following order:  $v_1, v_2, v'_2, v'_3, v''_3, v'''_3$ .  $\square$

$\square$

In Figures 3.2 to 3.5 we provide several useful non-colorable configurations. The important fact is that the non-colorable configurations can force the lists of colors on some vertices.

**Lemma 3.3.** The graphs depicted in Figure 3.2(i) to Figure 3.5(i) are 2-distance colorable unless their lists of available colors are exactly as indicated (up to renaming) in Figure 3.2(ii) to Figure 3.5(ii) respectively.

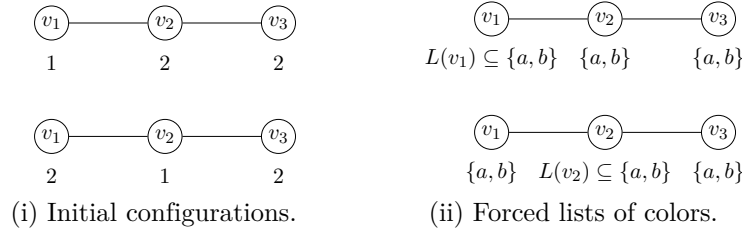

Hình 3.2: A non-colorable graph on 3 vertices.

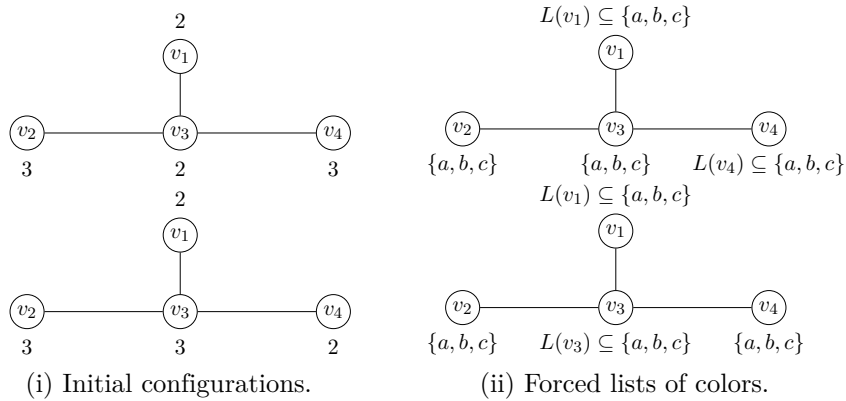

Hình 3.3: A non-colorable graph on 4 vertices.

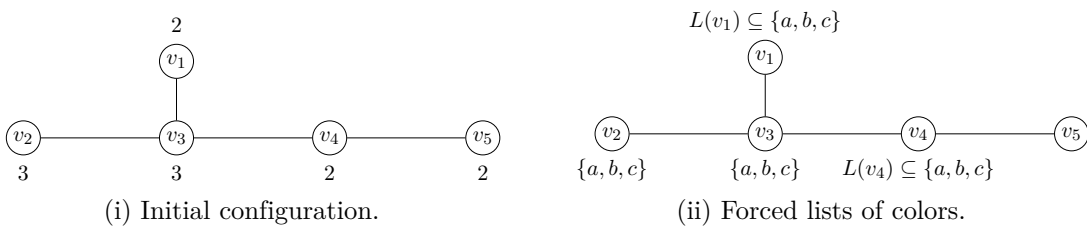

Hình 3.4: A non-colorable graph on 5 vertices.



Hình 3.5: A non-colorable graph on 5 vertices.

*Proof of Figure 3.2.* By Hall's Theorem, if  $|L(v_1) \cup L(v_2) \cup L(v_3)| \geq 3$ , then the graph is 2-distance colorable. Hence the forced lists in Figure 3.2ii follow. □

*Proof of Figure 3.3.* By Hall's Theorem, if  $|L(v_1) \cup L(v_2) \cup L(v_3) \cup L(v_4)| \geq 4$ , then the graph is 2-distance colorable. Hence the forced lists in Figure 3.3ii follow.  $\square$

*Proof of Figure 3.4.* First, observe that if  $|L(v_1)| \geq 4$  or  $|L(v_2)| \geq 4$ , we can color the other vertices by Figure 3.1i and finish with  $v_1$  or  $v_2$  respectively. If  $|L(v_4)| \geq 4$ , then we obtain Figure 3.1iv. Similarly, if  $|L(v_3)| \geq 4$ , then we obtain Figure 3.1v.

Also note that if  $|L(v_5)| \geq 3$ , then either  $v_1, v_2, v_3, v_4$  can be colored and we color  $v_5$  last. Or they cannot be colored and by Figure 3.3ii, we have Figure 3.4ii.

We will show that if  $v_1, v_2, v_3, v_4$  are colorable, then the whole configuration is colorable ( $v_5$  included). Thus, they cannot be colored and by Figure 3.3 (since all four vertices see each other at distance two), we obtain Figure 3.4ii.

So, let us assume that  $v_1, v_2, v_3, v_4$  are colorable, in which case,  $|L(v_1) \cup L(v_2) \cup L(v_3) \cup L(v_4)| \geq 4$  and  $|L(v_5)| = 2$ .

If  $L(v_5) \subseteq L(v_4)$ , then we restrict  $L(v_3)$  to  $L(v_3) \setminus L(v_5)$  and observe that  $|L(v_1) \cup L(v_2) \cup (L(v_3) \setminus L(v_5)) \cup L(v_4)| = |L(v_1) \cup L(v_2) \cup L(v_3) \cup L(v_4)| \geq 4$  since  $L(v_5) \subseteq L(v_4)$ . So, we can color  $v_1, v_2, v_3, v_4$  and finish by coloring  $v_5$ .

If  $L(v_5) \not\subseteq L(v_4)$ , then we restrict  $L(v_4)$  to  $L(v_4) \setminus L(v_5)$ . If  $|L(v_1) \cup L(v_2) \cup L(v_3) \cup (L(v_4) \setminus L(v_5))| \geq 4$ , then we can color  $v_1, v_2, v_3, v_4$  and finish with  $v_5$ . Thus,  $|L(v_1) \cup L(v_2) \cup L(v_3) \cup (L(v_4) \setminus L(v_5))| = 3$  and we can assume w.l.o.g. that  $L(v_1) \subseteq L(v_2) = L(v_3) = \{a, b, c\}$  and  $d \in L(v_4) \cap L(v_5)$  (which exists otherwise  $L(v_4) \setminus L(v_5) = L(v_4)$  and  $|L(v_1) \cup L(v_2) \cup L(v_3) \cup (L(v_4) \setminus L(v_5))| = |L(v_1) \cup L(v_2) \cup L(v_3) \cup L(v_4)| \geq 4$ ). Now, it suffices to color  $v_4$  with  $d$ , then color  $v_5, v_1, v_3, v_2$  in this order.  $\square$

*Proof of Figure 3.5.* First, observe that if  $|L(v_1)| \geq 3$ , then we can color the other vertices by Figure 3.1i and color  $v_1$  last. If  $|L(v_2)| \geq 3$ , then we obtain Figure 3.1ii. Symmetrically, the same holds for  $L(v_4)$  and  $L(v_5)$ . If  $|L(v_3)| \geq 5$ , we can color  $v_1, v_2, v_4, v_5, v_3$  in this order.

Now, let us try to color the configuration. If  $L(v_1) \neq L(v_2)$ , then color  $v_1$  with  $a \notin L(v_2)$  and get Figure 3.1i. Therefore we have  $L(v_1) = L(v_2)$  and symmetrically  $L(v_4) = L(v_5)$ . Finally, if  $L(v_1) \cup L(v_5) \neq L(v_3)$ , then one could color  $v_3$  with  $b \notin L(v_1) \cup L(v_5)$  and finish by coloring  $v_1, v_2, v_4, v_5$  in this order. Hence the lists in Figure 3.5ii follow.  $\square$

**Lemma 3.4.** If there exists a coloring  $\phi$  of the configuration from Figure 3.5i where  $\phi(v_1) \neq \phi(v_5)$ , then there exists a coloring  $\phi'$  such that  $\phi(v_1) \neq \phi'(v_1)$  or  $\phi(v_5) \neq \phi'(v_5)$ .

*Chứng minh.* Suppose that the configuration from Figure 3.5i is colorable with  $\phi$  where  $\phi(v_1) = a$ ,  $\phi(v_5) = b$  and  $a \neq b$ . Suppose by contradiction that for every coloring  $\phi'$  of Figure 3.5i,  $\phi'(v_1) = a$  and  $\phi'(v_5) = b$ .

Let  $L(v_1) = \{a, x\}$ . We color  $v_1$  with  $x$ . Since there exist no valid colorings  $\phi'$  where  $\phi'(v_1) = x$ , the remaining configuration must not be colorable. So  $x \in L(v_2)$ , otherwise, we can color  $v_2, v_3, v_4, v_5$  by Figure 3.1i. Let  $L(v_2) = \{x, y\}$ . Moreover,  $x, y \in L(v_3)$ . Otherwise, we color  $v_1$  with  $x$ ,  $v_2$  with  $y$  and finish by coloring  $v_4, v_5, v_3$  in this order.

Symmetrically, the same holds for  $v_5$ . Let  $L(v_5) = \{b, x'\}$ , then we must have  $L(v_4) = \{x', y'\}$  and  $x', y' \in L(v_3)$ .

Observe that when we color  $v_1$  with  $x$  and  $v_2$  with  $y$ , the remaining configuration is not colorable so by Figure 3.2, the remaining list of colors for  $v_3$  must be the same as  $L(v_5)$ , thus  $L(v_3) = \{x, y, b, x'\}$ . Symmetrically, if instead we color  $v_5$  with  $x'$  and  $v_4$  with  $y'$ , then the remaining list of colors for  $v_3$  must be the same as  $L(v_5)$ , thus  $L(v_3) = \{x', y', a, x\}$ . We conclude that  $\{x, x', b, y\} = \{x, x', a, y'\}$ . In other words,  $a = y$  and  $b = y'$ . Thus, we have  $L(v_1) = L(v_2) = \{a, x\}$ ,  $L(v_4) = L(v_5) = \{b, x'\}$  and  $L(v_3) = \{a, x, b, x'\}$ . By Figure 3.5, we know that this configuration is not colorable, which is a contradiction as there exists a valid coloring  $\phi$ .  $\square$



### 3.2 Structural properties of a minimal counterexample

---

Let  $G$  be a counterexample to Theorem 3.1 with the minimum number of vertices, namely a planar subcubic graph with  $g(G) \geq 8$  and  $\chi^2(G) \geq 7$ . For this and the following sections, the degree of a vertex will always be represented exactly in the figures so every vertex will be labeled with their name instead of being black or white.

First,  $G$  clearly verifies the following properties.

**Lemma 3.5.** Graph  $G$  is connected.

**Lemma 3.6.**  $\delta(G) \geq 2$ .

**Lemma 3.7.** Graph  $G$  has no  $k$ -threads with  $k \geq 2$ .

*Chứng minh.* Assume by contradiction that  $G$  has a  $k$ -thread with  $k \geq 2$ . We remove the 2-vertices of this thread and color the resulting graph. One can easily see that such coloring is greedily extendable to the removed 2-vertices.  $\square$

In order to simplify the reading of this chapter later on, the figures of the reducible configurations contain captions that will be explained later in Section 3.3.2.

In each of the reducible configurations, we define  $S$  as the set of all vertices labeled  $v_i$ ,  $v'_i$ ,  $v''_i$  or  $v'''_i$ , where  $i$  is a positive integer. In order to prove the reducibility of  $S$  we consider a 2-distance coloring  $\phi$  of  $G - S$  (by induction hypothesis) and show how to extend  $\phi$  to  $G$  leading to a contradiction. In each figure, the number drawn next to a vertex of  $S$  in the figure corresponds to the number of available colors in the precoloring extension of  $G - S$ .

Since  $G$  has girth  $g \geq 8$ , one can easily observe that  $G[S]^2 = G^2[S]$  for each configuration in Figure 3.6. In other words, there are no extra conflicts between vertices in  $S$  than the conflicts in  $G[S]$ . Unlike the configurations of Figure 3.6, in those of Figure 3.8, some pair of vertices may see each other in  $G$  while they are at distance at least 3 in the subgraph induced by  $S$ , that is sometimes  $G[S]^2 \neq G^2[S]$ .

**Lemma 3.8.** Graph  $G$  does not contain the configurations depicted in Figure 3.6.

*Chứng minh.* We will give the proofs for each figure in order:

*Proof of Figure 3.6i.* Color arbitrarily vertex  $v'_2$  and then get Figure 3.1ii.  $\square$

*Proof of Figure 3.6ii.* Direct implication of Figure 3.1viii.  $\square$

*Proof of Figure 3.6iii.* Direct implication of Figure 3.1vii.  $\square$

*Proof of Figure 3.6iv.* To prove this configuration, we redefine the set  $S$  to be  $\{v_1, v_2, v_3\}$ . Consider a 2-distance coloring  $\phi$  of  $G - S$ . If  $\phi$  is extendable to  $G$ , then we are done. Thus the available colors of vertices in  $S$  correspond to Figure 3.2. More precisely,  $L(v_2) \subseteq L(v_1) = L(v_3) = \{a, b\}$ . Now, uncolor vertices  $v_4, v_5, v_6$ , and  $v'_5$  and observe that the numbers of available colors of the non-colored vertices of  $G$  are the ones depicted in Figure 3.6iv.

Without loss of generality we may assume that  $\phi(v_4) = c$  and  $\phi(v_5) = d$ . Consequently, after the uncoloring of vertices  $v_4, v_5, v_6$ , and  $v'_5$ , we have  $L(v_3) = \{a, b, c, d\}$  and  $L(v_1) = \{a, b\}$ . If we can choose a color  $x \notin \{c, d\}$  for  $v_4$  and color vertices  $v_5, v_6$  and  $v'_5$ , then due to Figure 3.2, we can finish the coloring of  $v_1, v_2$ , and  $v_3$ . Observe that when  $v_4$  is colored  $x$ , the remaining number of available colors for  $v'_5, v_5$ , and  $v_6$  are at least 2 for each vertex. By Figure 3.2), we know that  $v'_5, v_5$ , and  $v_6$  must all have the same two remaining colors  $\{y, z\}$ . Thus, initially,  $L(v'_5) = L(v_5) = L(v_6) = \{x, y, z\} \in \{a, b, c, d, e, f\}$ . Note that  $\phi(v_4) = c \notin \{x, y, z\}$ , otherwise  $\phi$  would not be a valid coloring of  $G - S$ . Now, we color  $v_4$  with  $c$ ,  $v_5$  with a color different from  $d$ , then  $v'_5$  and  $v_6$ . Finally, due to Figure 3.2 we can finish by coloring  $v_1, v_2, v_3$  since the lists of available colors for  $v_1$  and  $v_3$  are not the same anymore.  $\square$

*Proof of Figure 3.6v.* Direct implication of Figure 3.1xi.  $\square$

*Proof of Figure 3.6vi.* Color  $v'_3$  with a color  $a \notin L(v''_3)$ , and color  $v_4, v_5$  in order. Then color vertices  $v_1, v_2, v_3, v'_2, v''_2, v'''_2$  by Figure 3.1vii and finish by coloring  $v'''_3$  and  $v'_3$  in this order.  $\square$

*Proof of Figure 3.6vii and Figure 3.6viii.* Direct implication of Figure 3.1xvi for Figure 3.6viii. As for Figure 3.6vii, it suffices to see that by adding an imaginary vertex  $v_6$  adjacent to  $v_5$  with any list of colors that verifies  $|L(v_6)| \geq 2$ , Figure 3.1xvi gives us a valid coloring for vertices of Figure 3.6vii.  $\square$

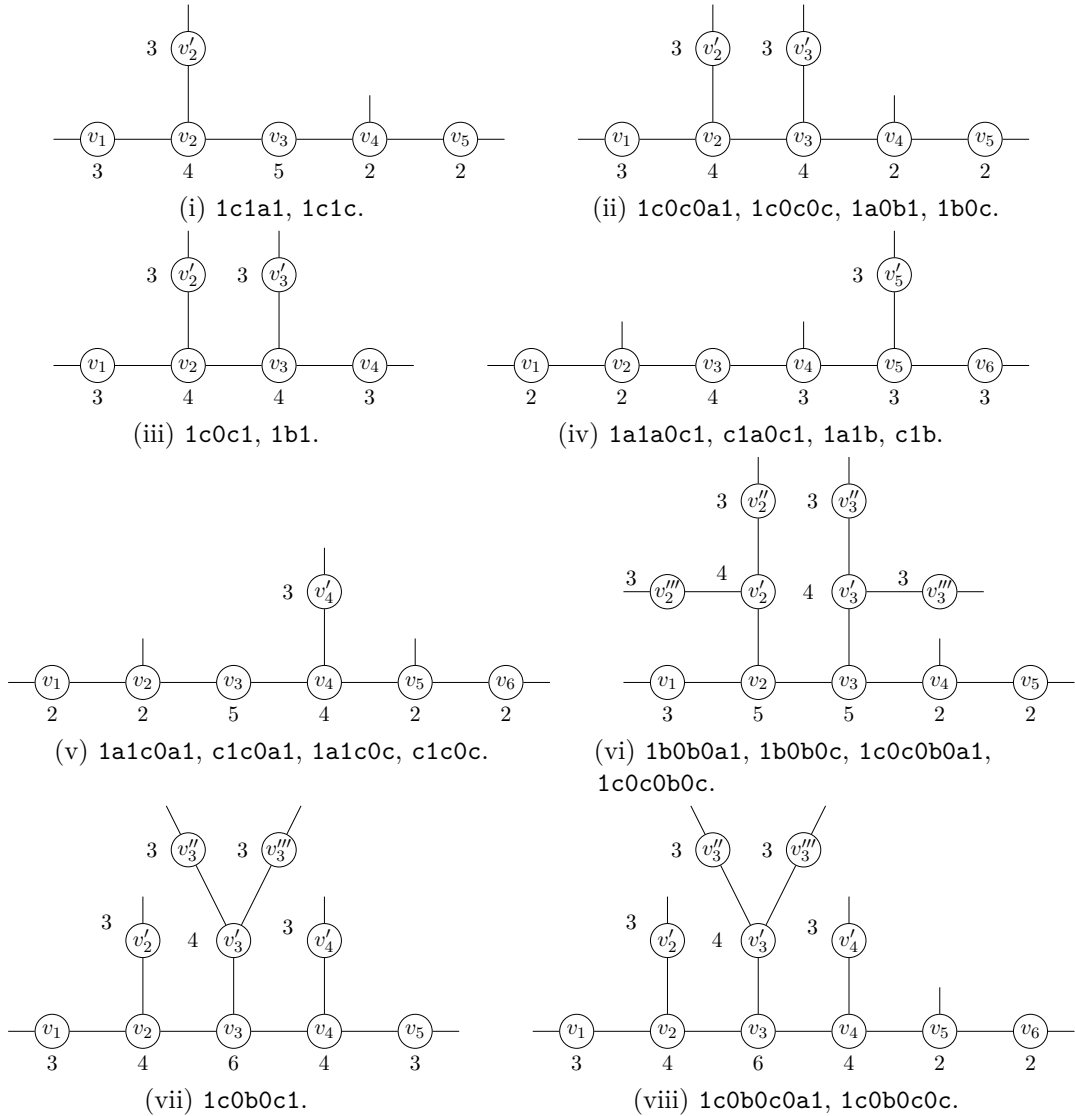

Hình 3.6: Reducible configurations in Lemma 3.8.

**Lemma 3.9.** Graph  $G$  does not contain the configurations depicted in Figure 3.7.

*Chứng minh.*

*Proof of Figure 3.7i.* Here, we redefine  $S = \{v_0, v_1, v_2, v_3, v_4\}$ . By Figure 3.5,  $L(v_0) = L(v_1) = \{a, b\}$ ,  $L(v_3) = L(v_4) = \{c, d\}$  and  $L(v_2) = \{a, b, c, d\}$ . Therefore, we can assume w.l.o.g that  $v_6$  is colored  $e$ . Since  $|L(v_0)| = 2$ , all of the colored vertices that  $v_0$  sees must be colored differently. The same holds for  $v_4$ . However, it means that  $v_2$  does not see the color  $e$ , which is impossible since  $L(v_2) = \{a, b, c, d\}$ .  $\square$

*Proof of Figure 3.7ii.* Note that  $G[S]^2 = G^2[S]$ . We first prove three important observations.

- $L(v_7) \neq L(v'_6)$ . Suppose the contrary and color  $v_7, v_6, v'_6, v_5, v'_5, v_4, v_3$  by Figure 3.1viii. Now if  $v_0, v_1$ , and  $v_2$  are colorable, then we are done. Thus according to Figure 3.2, we can assume that  $L(v_1) \subset L(v_0) = L(v_2)$ . But then, since by our assumption  $L(v_7) = L(v'_6)$ , we permute the colors of  $v'_6$  and  $v_7$  so that  $L(v_0) \neq L(v_2)$  and we are done.
- $L(v_3) \subset L(v_2) \supset L(v_4)$ . If not, then color  $v_3$  and  $v_4$  such that  $|L(v_2)| \geq 3$ . Recall that  $L(v_7) \neq L(v'_6)$ . Hence we color  $v'_5, v_5, v_6, v'_6, v_7$  by Figure 3.4. We finish by coloring  $v_1, v_0, v_2$  in this order.
- $L(v_1) \cap L(v_4) = \emptyset$ . By contradiction, suppose  $a \in L(v_1) \cap L(v_4)$ . We will show the following observations.
  - $a \notin L(v'_6)$ . If  $a \in L(v'_6)$ , then we color  $v_1, v_4$  and  $v'_6$  with  $a$ . Then, we color  $v_3$ . After that, we color  $v'_5, v_5, v_6, v_7$  by Figure 3.1i and we finish by coloring  $v_0$  and  $v_2$  in this order.
  - $a \in L(v_7)$ . If  $a \notin L(v_7)$ , then we color  $v_1$  and  $v_4$  with  $a$ . Then, we color  $v_3$ . After that, we color  $v'_5, v_5, v_6, v'_6, v_7$  by Figure 3.4 (recall that  $L(v'_6) \neq L(v_7)$ ) and finish by coloring  $v_0$  and  $v_2$  in this order.
  - $a \in L(v'_5)$ . If  $a \notin L(v'_5)$ , then we color  $v_4$  and  $v_7$  with  $a$ . Then, we color  $v_3$ . Finally, we finish by coloring  $v_1, v_2, v_0, v_6, v_5, v'_6, v'_5$  in this order.
  - $|L(v_3) \setminus \{a\}| = 1$ . Otherwise, we color  $v_4$  and  $v_7$  with  $a$ . Then, we color  $v_5$  in such a way that  $v_3$  has at least 2 colors left. After that, we color  $v'_5, v_5, v_6, v_7$  in this order. Finally, we finish by coloring  $v_3, v_2, v_1, v_0$  by Figure 3.1i.

Thus, we color  $v'_5, v_3$ , and  $v_7$  with  $a$ , then we color the remaining vertices in the following order:  $v_4, v_2, v_1, v_0, v_6, v_5, v'_6$ .

Since  $L(v_1) \cap L(v_4) = \emptyset$ , we assume w.l.o.g. that  $L(v_4) \subseteq \{a, b, c\}$  and  $L(v_1) = \{d, e, f\}$ . As  $L(v_3) \subset L(v_2) \supset L(v_4)$ , there exists a color, say  $d$ , in  $L(v_1)$  such that after coloring  $v_1$  with  $d$ , we have  $|L(v_2)| \geq 4$  and  $|L(v_3)|, |L(v_3)| \geq 2$ . In conclusion, we color  $v_1$  with  $d$ ,  $v_7, v_6, v'_6, v_5, v'_5, v_4, v_3$  by Figure 3.1viii and finish by coloring  $v_0$  and  $v_2$  in this order.

□

*Proof of Figure 3.7iii.* If  $v'_2$  sees  $v'_6$ , then they are at distance exactly 2 and share a common neighbor, say  $v_8$ . Then vertices  $v'_6, v_8, v'_2, v_2, v_3, v_4, v_5, v_6$  correspond to the reducible configuration of Figure 3.7i.

Therefore, we can assume that  $G[S]^2 = G^2[S]$ . Color  $v_2$  with  $x \notin L(v'_2)$  and color greedily  $v_1$ . Then color vertices  $v_4, v_5, v'_5, v_6, v'_6, v_7, v_0$  by Figure 3.1viii and finish by coloring  $v_3$  and  $v'_2$  in this order.

□

*Proof of Figure 3.7iv.* If  $v''_5$  sees  $v_1$  by sharing a common neighbor, say  $v_8$ , then vertices  $v''_5, v'_5, v''_5, v_8, v_1, v_2, v_0$  form the reducible configuration of Figure 3.6iv. The case when  $v'''_5$  sees  $v_1$  is symmetric.

Therefore, we can suppose that  $G[S]^2 = G^2[S]$ . First we show that  $L(v_1) \cap L(v_7) = \emptyset$ . Suppose the contrary and color  $v_1$  and  $v_7$  with a same color. Then restrict  $L(v_5)$  to  $L(v_5) \setminus L(v''_5)$  and color vertices  $v_6, v_5, v_4, v'_4, v_3$  by Figure 3.1v. Finish by coloring vertices  $v'_5, v'''_5, v''_5, v_7, v_2, v_0$  in this order.

Observe that  $L(v_1) \subset L(v_0)$ . Therefore, since  $L(v_1) \cap L(v_7) = \emptyset$  and since we are doing a 6-coloring, we conclude that  $L(v'_7) \not\subset L(v_0)$ .

We color  $v'_5$  with  $x \notin L(v''_5)$  and  $v_6, v_5, v_4, v'_4, v_3$  by Figure 3.1iv. Then we color  $v'''_5$  and  $v''_5$  in this order. Observe the remaining uncolored vertices are  $v'_7, v_7, v_0, v_1$ , and  $v_2$ . If the lists of available colors of these vertices, do not correspond to Figure 3.5, then we are done. And it is indeed the case, since the only colored vertex seen by both  $v_0$  and  $v'_7$  is  $v_6$ , and since initially  $L(v'_7) \not\subset L(v_0)$ .

□

*Proof of Figure 3.7v.* We have  $G[S]^2 = G^2[S]$ . Color vertices  $v_0$  and  $v_4$  with the same color by pigeonhole principle and then  $v_3, v_1$ , and  $v_2$  in this order. The remaining vertices can be colored by Figure 3.1x.

(□)

*Proof of Figure 3.7vi.* If  $v'_3$  sees  $v'_7$ , then they must be at distance exactly 2 since  $G$  has girth 8. Say  $v_8$  is their common neighbor, then  $v_0, v_7, v'_7, v_8, v'_3, v_3, v_2$ , and  $v_1$  form the reducible configuration from Figure 3.7i.

Thus, we have  $G[S]^2 = G^2[S]$ . First, observe that  $|L(v'_7)| = |L(v'_5)| = |L(v'_6)| = 3$  and we will prove the following:

- $L(v_6) = L(v'_7)$ . Otherwise, color  $v_6$  differently from  $L(v'_7)$ , then color  $v_1$  and  $v_2$  in this order. Color  $v'_5, v_5, v_4, v_3$ , and  $v'_3$  by Figure 3.1xiii. Finish by coloring  $v_7, v_0$ , and  $v'_7$  in this order.
- $L(v_6) = L(v'_5)$ . Otherwise, color  $v_6$  differently from  $L(v'_5)$ , then color  $v'_7, v_7, v_0, v_1$ , and  $v_2$  by Figure 3.1ii. Finish by coloring  $v'_3, v_3, v_5, v_4$ , and  $v'_5$  in this order.
- $L(v_1) \cap L(v'_7) = \emptyset$ . Otherwise, color  $v_1$  and  $v'_7$  with  $x \in L(v_1) \cap L(v'_7)$ . Then, color  $v_2$  and  $v_6$ . Color  $v'_5, v_5, v_4, v_3$ , and  $v'_3$  by Figure 3.1xiii. Finish by coloring  $v_7$  and  $v_0$  in this order.

Using the equalities above, we have the following. Color  $v_7$  differently from  $L(v_6)$  and  $L(v'_7)$ . Now, color  $v_1$  and  $v_4$  with the same color, which is possible since  $v_4$  has all six colors available. Observe that, since  $L(v_1) \cap L(v'_7) = \emptyset$  and  $L(v'_7) = L(v_6) = L(v'_5)$ ,  $v_6$  and  $v_5$  still have the same amount of available colors remaining. Finish by coloring  $v_2, v'_3, v_3, v_5, v_6, v'_5, v_0$ , and  $v'_7$  in this order.

(□)

*Proof of Figure 3.7vii.* Note that  $G[S]^2 = G^2[S]$ . Here, we redefine  $S = \{v_0, v_1, v'_1, v_2\}$ . Consider  $\phi$  a coloring of  $G - S$ . Note that if  $\phi$  is extendable to  $G$ , then we have a contradiction. Thus,  $L(v_0) = L(v_1) = L(v'_1) = L(v_2) = \{a, b, c\}$  by Figure 3.3. Now, we uncolor  $v_3, v_4, v'_4, v_5, v_6, v'_6, v_7$  and note that the number of available colors correspond to what is depicted in Figure 3.7vii. We assume w.l.o.g. that  $L(v_0) = \{a, b, c, d, e\}$  where  $d = \phi(v_7)$  and  $e = \phi(v_6)$ . Observe that  $L(v'_6) \neq L(v_7)$ , otherwise, we can permute the colors of  $v'_6$  and  $v_7$  in  $\phi$  and extend  $\phi$  to  $G$  as  $L(v_0)$  would no longer be  $\{a, b, c\}$ . Symmetrically,  $L(v_3) \neq L(v'_4)$ .

If  $d \notin L(v'_6)$ , then we can color  $v_7$  with  $d$ ,  $v_6$  with  $x \neq e$ ,  $v_5$ , then  $v_3, v_4, v'_4$  by Figure 3.2 since  $L(v_3) \neq L(v'_4)$ , and finish by coloring  $v'_6$ . As  $L(v_0) \neq \{a, b, c\}$ ,  $\phi$  is extendable to  $G$ .

Now,  $d \in L(v'_6)$ . In which case, there exists  $y \in L(v_7) \setminus L(v'_6)$ . So we color  $v_7$  with  $y$ ,  $v_6$  with  $z \neq d$ ,  $v_5$ , then  $v_3, v_4, v'_4$  and finish by coloring  $v'_6$ . Finally,  $\phi$  is extendable to  $G$  because  $L(v_0) \neq \{a, b, c\}$ .

(□)

□

**Lemma 3.10.** Graph  $G$  does not contain the configurations depicted in Figure 3.8.

*Chứng minh. Proof of Figure 3.8i.* If  $v_1$  does not see  $v_7$ , then the proof is a direct implication of Figure 3.1xv. If  $v_1$  sees  $v_7$ , then they must be at distance exactly 2 since  $G$  has girth at least 8 and therefore  $|L(v_1)| \geq 3$  and  $|L(v_7)| \geq 3$ . We color  $v_1$  such that  $v_2$  has at least 2 colors left. We then obtain Figure 3.1xiii.

(□)

*Proof of Figure 3.8ii.* If  $v_1$  sees  $v'_6$ , then they must be at distance exactly 2 since  $G$  has girth at least 8. Say  $v_0$  is their common neighbor, then  $v'_6, v_0, v_1, \dots, v_6$  form the reducible configuration from Figure 3.7i. If  $v_1$  sees  $v_7$ , then they share a common neighbor  $v_0$  and  $v_1, v_2, v_3, v_4, v_5, v'_5, v_6, v'_6, v_7, v_8, v_0$  form the reducible configuration from Figure 3.7ii. If  $v_2$  sees  $v_8$ , then they share a common neighbor  $v'_2$  and  $v_8, v'_2, v_2, v_1, v_3, v_4, v_5, v'_5, v_6, v'_6, v_7$  form the reducible configuration from Figure 3.7iii.

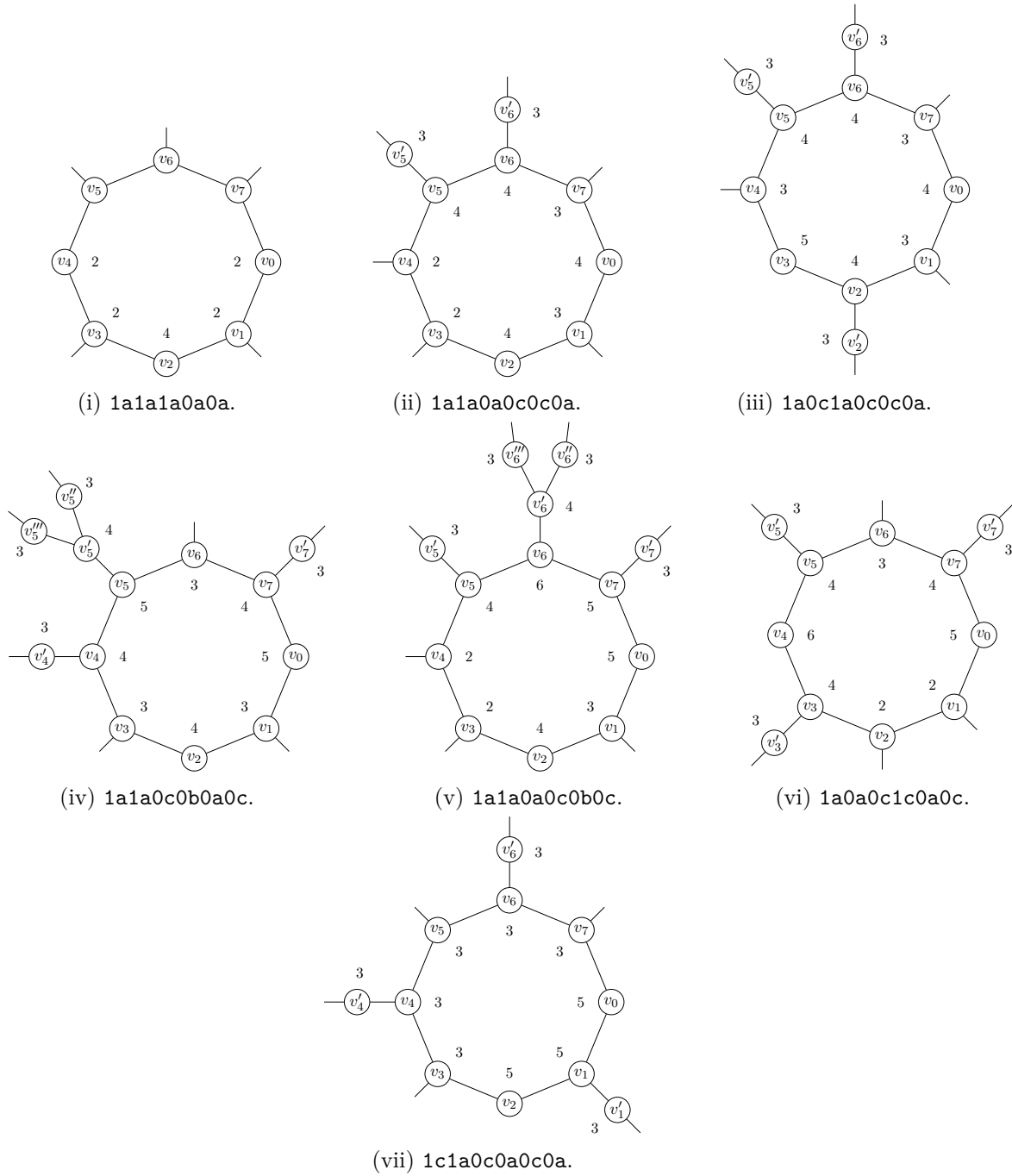

Hình 3.7: Reducible configuration in Lemma 3.9.

If  $v_1$  sees  $v_8$ , they must be at distance exactly 2 since both are 2-vertices and there are no 2-threads due to Lemma 3.7. Thus,  $3 \leq |L(v_1)|, |L(v_8)| \leq 4$ . If we can color  $v_2$  such that  $v_1$  has at least 3 colors left, then we can color  $v_4, v_5, v'_5, v_6, v'_6, v_7, v_8$  by Figure 3.1viii and finish by coloring  $v_3$  and  $v_1$  in this order. Therefore,  $|L(v_1)| = 3$  and  $L(v_2) \subseteq L(v_1)$ . We color  $v_3$  with  $x \notin L(v_1)$ . Then, we color  $v_4, v_5, v'_5, v_6, v'_6, v_7$  by Figure 3.1vii and finish by coloring  $v_8, v_2$ , and  $v_1$  in this order.

Now,  $G[S]^2 = G^2[S]$ . If we can color  $v_2$  such that  $v_1$  has at least 2 colors left, then we can color  $v_4, v_5, v'_5, v_6, v'_6, v_7, v_8$  by Figure 3.1viii, and finish by coloring  $v_3$  and  $v_1$  in this order. Therefore,  $L(v_1) = L(v_2)$  and  $|L(v_1)| = 2$ . We restrict  $L(v_3)$  to  $L(v_3) \setminus L(v_1)$ . Then, we color  $v_3, v_4, v_5, v'_5, v_6, v'_6, v_7, v_8$  by Figure 3.1ix and finish by coloring  $v_2$  and  $v_1$  in this order.

*Proof of Figure 3.8iii.* If  $v_3''$  sees  $v_7$ , then they must be at distance exactly 2 since  $G$  has girth 8. Say  $v_8$  is their common neighbor, then  $v_3'', v_3', v_3''', v_8, v_7, v_6, v_6'$  form the reducible configuration from Figure 3.8i. Note that the cases when  $v_3'''$  sees  $v_7$ , or  $v_3''$  sees  $v_6'$ , or  $v_3''$  sees  $v_7$  are symmetric.

Observe that since  $v_1$  cannot see both  $v_6'$  and  $v_7$ , we can assume that  $v_1$  does not see  $v_6'$ . Note that in this case  $|L(v_6')| = 3$ . Thus we restrict  $L(v_5)$  to  $L(v_5) \setminus L(v_6')$  and  $L(v_4)$  to  $L(v_4) \setminus L(v_4'')$ . We color vertices  $v_5, v_4, v_3, v_2, v_1, v_3', v_3'', v_3'''$  by Figure 3.1x. Then finish by coloring  $v_5', v_4', v_4'', v_4''', v_6, v_7, v_6'$  in this order. □

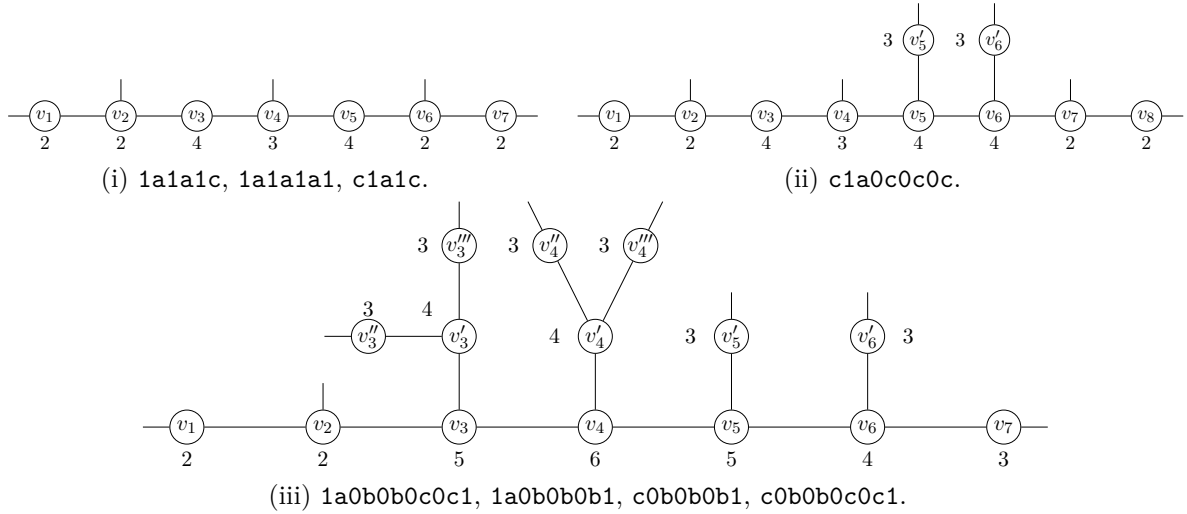

Hình 3.8: Reducible configurations in Lemma 3.10.

**Lemma 3.11.** Consider the configuration in Figure 3.9. If  $v_3, v_4, v_5, v_6,$  and  $v_7$  are colorable, but the configuration as a whole is not, then  $L(v_3) = L(v_4) = L(v_6) = L(v_7) = L(v_1) \setminus L(v_1')$  and  $|L(v_3)| = 2$ .

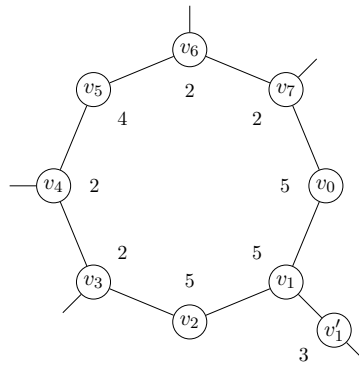

Hình 3.9: 1c1a0a1a0a.

*Chứng minh.* First, observe that we have  $G[S]^2 = G^2[S]$ . We color  $v_3, v_4, v_5, v_6,$  and  $v_7$ . Observe that  $|L(v_0)| = |L(v_2)| = |L(v_1')| = 3$  and  $|L(v_1)| \geq 3$ . So, the remaining vertices are not colorable if and only if  $L(v_0) = L(v_1) = L(v_1') = L(v_2) = \{a, b, c\}$  w.l.o.g. due to Figure 3.3.

Now, let  $\{d, e\} = L(v_1) \setminus L(v_1')$  and uncolor  $v_3, v_4, v_5, v_6,$  and  $v_7$ . Due to our previous observations, we can assume w.l.o.g. that  $v_3$  and  $v_7$  must have been colored  $d$  and  $e$  respectively. Moreover, due to Lemma 3.4, since we know that  $v_3, v_4, v_5, v_6,$  and  $v_7$  are colorable, there exists another coloring of these vertices where  $v_3$  is not colored  $d$  or  $v_7$  is not colored  $e$ . As  $v_0, v_1, v_1',$

and  $v_2$  must remain uncolorable, we know that  $v_3$  must have been colored  $e$  and  $v_7$  colored  $d$ . So, we know that  $\{d, e\} \subseteq L(v_3)$  and  $\{d, e\} \subseteq L(v_7)$ . In addition, when  $v_3$  was colored  $d$  (resp.  $e$ ),  $d$  (resp.  $e$ ) must be in  $L(v_2)$  or we would have had  $|L(v_2)| \geq 4$  after the coloring of  $v_3, v_4, v_5, v_6$ , and  $v_7$ . In other words,  $L(v_2) = \{a, b, c, d, e\}$ . Symmetrically, the same holds for  $L(v_0)$ . Knowing that  $L(v_2) = \{a, b, c, d, e\}$ , when  $v_3$  was colored  $d$  (resp.  $e$ ),  $v_4$  must have been colored  $e$  (resp.  $d$ ). So we get  $\{d, e\} \subseteq L(v_4)$ . Similarly, the same holds for  $L(v_6)$ . Finally, if any of  $v_3, v_4, v_6$ , or  $v_7$  has another available color  $x \notin \{d, e\}$ , we could have colored that vertex with  $x$ , and finish coloring the rest of the configuration due to Figure 3.5 and Figure 3.3, which is impossible. Consequently, we have  $L(v_3) = L(v_4) = L(v_6) = L(v_7) = L(v_1) \setminus L(v'_1) = \{d, e\}$ .  $\square$

**Lemma 3.12.** The configurations in Figure 3.10 are colorable.

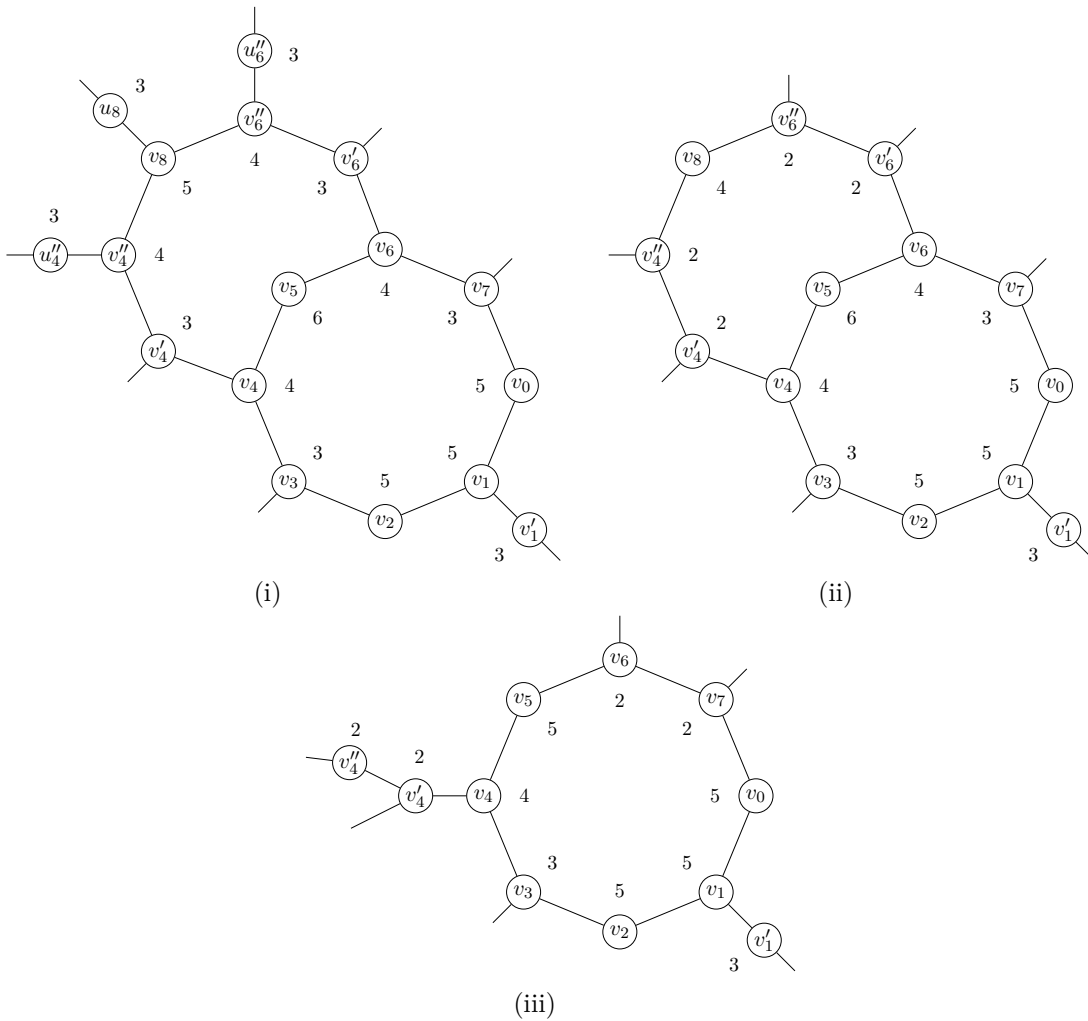

Hình 3.10: Reducible configurations in Lemma 3.12.

*Chứng minh.* The outline of each proof uses the same conventions as before.

*Proof of Figure 3.10i.* If  $v'_1 = u_8$ , then  $|L(v'_1)| = |L(u_8)| = |L(v_1)| = 6$ . Now, consider the two following cases:

- If there exists  $x \in L(v_3) \cap L(v_7)$ , then color  $v_3$  and  $v_7$  with  $x$ . Color  $v'_6$  such that  $u''_6$  still has 3 colors remaining, then  $v'_6$  and  $v_6$  in this order. Color  $v_4, v'_4, v''_4$ , and  $u''_4$  by Figure 3.1i. Finish by coloring  $v_5, v_8, u''_6, v'_1 (= u_8), v_0, v_2$ , and  $v_1$  in this order.

- If  $L(v_3) \cap L(v_7) = \emptyset$ , then we show the following. Suppose that there exists a coloring  $\phi$  of  $v'_4, v''_4, u''_4, v_8, v'_6, v''_6$ , and  $u''_6$  such that  $v_3, v_4, v_5, v_6$ , and  $v_7$  are colorable afterwards. Then, we obtain the configuration from Lemma 3.11 where  $v_3, v_4, v_5, v_6$ , and  $v_7$  are colorable but  $L(v_3) \cap L(v_7) = \emptyset$ . Thus, we can finish the coloring.

Now, we show the existence of  $\phi$ . We can start by coloring  $v''_4$  such that  $u''_4$  still has 3 colors remaining. Similarly, color  $v_6$  such that  $v_7$  still has 3 colors remaining. Then, we can color  $v'_4, v_4, v_3, v_5, v'_6, v_7, v''_6, u''_6, v_8$ , and  $u''_4$  in this order. This coloring restricted to  $v'_4, v''_4, u''_4, v_8, v'_6, v''_6$ , and  $u''_6$  gives us  $\phi$  such that  $v_3, v_4, v_5, v_6$ , and  $v_7$  are colorable afterwards.

Now,  $v'_1 \neq u_8$ . Observe that  $v'_1$  might see  $u''_4$  and if it does, then they must be at distance exactly 2 since  $G$  has no  $2^+$ -threads due to Lemma 3.7. Symmetrically, the same holds if  $v'_1$  sees  $u''_6$ . The following colorings will still work when  $v'_1$  sees  $u''_4$  or  $u''_6$ .

Consider the two following cases:

- If  $|L(v_3) \cap L(v_7)| \geq 2$ , say  $\{d, e\} \subset L(v_3) \cap L(v_7)$ , then let  $x \in L(v_3) \setminus \{d, e\}$ . We restrict  $L(v'_4)$  to  $L(v'_4) \setminus \{x\}$  and we color  $v'_6$  differently from  $\{d, e\}$ . Color  $v'_4, v''_4, u''_4, v_8, u_8, v''_6$ , and  $u''_6$  by Figure 3.1viii.

Observe that we obtain the configuration from Figure 3.7vii where  $v_3, v_4, v_5, v_6$ , and  $v_7$  are colorable by Figure 3.5 since  $L(v_3)$  and  $L(v_7)$  will have at least one color in common. Moreover, we will have either  $L(v_7) = \{d, e\}$  and  $x \in L(v_3) \setminus \{d, e\}$ , or  $|L(v_7)| \geq 3$ , both of which means that the remaining configuration is colorable by Lemma 3.11.

- If  $|L(v_3) \cap L(v_7)| \leq 1$ , then we show the following. Suppose that there exists a coloring  $\phi$  of  $v'_4, v''_4, u''_4, v_8, u_8, v'_6, v''_6$ , and  $u''_6$  such that  $v_3, v_4, v_5, v_6$ , and  $v_7$  are colorable afterwards. Then, we obtain the configuration from Lemma 3.11 where  $v_3, v_4, v_5, v_6$ , and  $v_7$  are colorable but  $|L(v_3) \cap L(v_7)| \leq 1$ . Thus, we can finish the coloring.

Now, we show the existence of  $\phi$ . We can start by coloring  $v''_4$  such that  $u''_4$  still has 3 colors remaining. Similarly, color  $v_6$  such that  $v_7$  still has 3 colors remaining. Then, color  $v'_6$ . Color  $u''_6, v''_6, v_8$ , and  $u_8$  by Figure 3.1i. Finish by coloring  $v'_4, u''_4, v_4, v_3, v_5$ , and  $v_7$  in this order. This coloring restricted to  $v'_4, v''_4, u''_4, v_8, u_8, v'_6, v''_6$ , and  $u''_6$  gives us  $\phi$  such that  $v_3, v_4, v_5, v_6$ , and  $v_7$  are colorable afterwards.

(□)

*Proof of Figure 3.10ii.* If  $v'_1$  sees  $v''_4$ , then they must be at distance exactly 2 since  $G$  has girth 8. Say  $v$  is their common neighbor, then  $v'_1, v_1, v_0, v_2, v_3, v_4, v_5, v'_4, v''_4$ , and  $v$  form the reducible configuration from Figure 3.7vii. Symmetrically, the same holds if  $v'_1$  sees  $v''_6$ .

So we have  $G[S]^2 = G^2[S]$ .

We redefine  $S = \{v_0, v_1, v'_1, v_2\}$  and let  $\phi$  be the coloring of the rest of the graph. Now we uncolor the rest of the configuration and we have the corresponding list of colors as in Figure 3.10ii.

After coloring  $v'_4, v''_4, v_8, v'_6$ , and  $v''_6$  with  $\phi$ , the remaining colors for  $v_3, v_4, v_6, v_7$  must be the same two colors, say  $\{d, e\}$  (determined by  $L(v_1) \setminus L(v'_1)$ ), or the whole configuration would be colorable by Lemma 3.11. We can also deduce that  $L(v_3) = \{d, e, \phi(v'_4)\}$ . Similarly,  $L(v_7) = \{d, e, \phi(v'_6)\}$ . Now, thanks to Lemma 3.4, we know there exists another coloring  $\phi'$  of  $v'_4, v''_4, v_8, v''_6$ , and  $v'_6$  such that  $\phi'(v'_4) \neq \phi(v'_4)$  or  $\phi'(v'_6) \neq \phi(v'_6)$ . Say w.l.o.g. that  $\phi'(v'_4) \neq \phi(v'_4)$ . As a result,  $v_3, v_4, v_5, v_6$ , and  $v_7$  is colorable by Figure 3.5 and  $L(v_3) \neq \{d, e\}$  so the configuration is colorable by Lemma 3.11.

(□)

*Proof of Figure 3.10iii.* If  $v'_1$  sees  $v''_4$ , then they must be at distance exactly 2 since  $G$  has girth 8. Say  $v$  is their common neighbor, then  $v''_4, v, v'_1, v_1, v_2, v_3, v_4$ , and  $v'_4$  form the reducible configuration from Figure 3.7i.

Now, we have  $G[S]^2 = G^2[S]$ .



We redefine  $S = \{v_0, v_1, v'_1, v_2\}$  and let  $\phi$  be the coloring of the rest of the graph. Now we uncolor  $v_3, v_4, v'_4, v''_4, v_5, v_6$ , and  $v_7$  and we have the corresponding list of colors as in Figure 3.10iii.

Let  $\{d, e\} \subseteq L(v_6)$ .

If  $\{d, e\} \subseteq L(v_3)$ , then we color  $v'_4$  differently from  $L(v_3) \setminus \{d, e\}$  and color  $v''_4$ . As a result,  $v_3, v_4, v_5, v_6$ , and  $v_7$  are colorable by Figure 3.5 and  $L(v_3) \neq \{d, e\} \subseteq L(v_6)$  so the configuration is colorable by Lemma 3.11.

If  $\{d, e\} \not\subseteq L(v_3)$ , then since  $v_3, v_4, v'_4, v''_4, v_5, v_6$ , and  $v_7$  was colorable with  $\phi$ , we recolor  $v'_4$  and  $v''_4$  with  $\phi(v'_4)$  and  $\phi(v''_4)$  respectively. Now, observe that  $v_3, v_4, v_5, v_6$ , and  $v_7$  are colorable but  $L(v_3) \neq L(v_6)$  so the configuration is colorable by Lemma 3.11.  $\square$

The rest of the configurations along with their proofs can be found in (Lemma 10 of) our paper [90] that is in the Appendix. It follows the same scheme as Lemma 3.9 and uses Section 3.1 as well as the previous lemmas. There are more than 30 configurations and their proofs are quite tedious, but do not contribute extra value to what we already know, even though they are necessary.

Due to the large amount of configurations, we have started out by coloring these configurations by computer (by testing all precoloring of the set of vertices separating our configuration from the rest of the graph) but this process was very time consuming. Moreover, there are tricks that can be done manually (restricting the considered set of vertices in the configurations, uncoloring then recoloring part of the configuration) that can hardly be replicated by computer. Concretely, it means that not all precoloring is a possible precoloring of a proper subgraph of  $G$  and we cannot know which precoloring to test, which not to with our naive approach. Thus, we opted to prove the reducibility of every configuration “manually”.

### 3.3 Discharging procedure

---

**Charge distribution:** Euler’s formula can be rewritten as

$$\sum_{v \in V(G)} \left( \frac{7}{2}d(v) - 9 \right) + \sum_{f \in F(G)} (d(f) - 9) = -18. \quad (3.1)$$

We assign to each vertex  $v$  the charge  $\mu(v) = \frac{7}{2}d(v) - 9$  and to each face  $f$  the charge  $\mu(f) = d(f) - 9$ . To prove the non-existence of  $G$ , we will redistribute the charges preserving their sum and obtaining a non-negative total charge, which will contradict Equation (3.1).

To do so, we will divide the discharging procedure into multiple rounds. In the first round, we will redistribute the charges only between the vertices of  $G$ , resulting in a non-negative amount of charge on each vertex. For the second round, first observe that  $\mu(f) = d(f) - 9 \geq 0$  for every face  $f$  of size at least 9. Therefore, since  $g(G) \geq 8$  and  $\mu(f) = -1$  for every 8-face  $f$ , we will redistribute the remaining charges on each vertex over the non-reducible 8-faces to obtain a non-negative amount of charge on faces. The third round is there to patch up some remaining problems surrounding faces that still have a negative charge after the second round. Thus, we will get a non-negative total of charge, which is a contradiction to Equation (3.1). In our proof, we have to consider a large number of non-reducible 8-faces. To handle this, we will provide a computer procedure that checks the remaining charge on each non-reducible 8-face. In order to define this procedure, we will present an encoding of the 8-faces, the reducible configurations, and the discharging rules.

#### 3.3.1 First round: vertices to vertices

We define the following discharging rules on the vertices of  $G$  :

**R0** A 3-vertex gives 1 to a 2-neighbor.

**R1** A 3-vertex gives  $\frac{1}{2}$  to a (1,1,0)-neighbor.

**R2** A 3-vertex gives  $\frac{1}{2}$  to a (1,1,1)-vertex at distance 2.

We will now calculate the exact amount  $\mu^*(v)$  of charges that  $v$  ends up with after applying **R0**, **R1**, and **R2**.

**Case  $d(v) = 2$ :** Recall that the initial charge for  $v$  is  $\mu(v) = \frac{7}{2}d(v) - 9 = -2$ . By Lemma 3.7,  $v$  can only have 3-neighbors. According to the discharging rules,  $v$  receives 1 from each of its neighbor by **R0** and does not give any charge away. Thus,  $v$  ends up with

$$\mu^*(v) = -2 + 2 \cdot 1 = 0.$$

**Case  $d(v) = 3$ :** Recall that the initial charge is  $\mu(v) = \frac{7}{2}d(v) - 9 = \frac{3}{2}$ .

- Suppose  $v$  is a (1, 1, 1)-vertex.

Every neighbor of  $v$  is a 2-vertex so only **R0** and **R2** may apply. However, due to Figure 3.6i, there is no (1, 1, 0<sup>+</sup>)-vertices at distance 2 from  $v$ . So,  $v$  does not give away any charge to distance 2 3-vertices but only receives instead by Lemma 3.7. Thus, by **R0** and **R2**, we have

$$\mu^*(v) = \frac{3}{2} - 3 \cdot 1 + 3 \cdot \frac{1}{2} = 0.$$

- Suppose  $v$  is a (1, 1, 0)-vertex.

Due to Figure 3.6i, there is no (1, 1, 1)-vertices at distance 2 from  $v$  so **R2** does not apply. Due to Figure 3.6iii,  $v$  cannot have a (1, 1, 0)-neighbor. So,  $v$  does not give away any charge to 3-vertices but only receive by **R1** instead. Thus, by **R0** and **R1**, we have

$$\mu^*(v) = \frac{3}{2} - 2 \cdot 1 + \frac{1}{2} = 0.$$

- Suppose  $v$  is a (1, 0, 0)-vertex.

- If  $v$  has a (1, 1, 0)-neighbor, then  $v$  cannot have another (1, 0<sup>+</sup>, 0)-neighbor due to Figure 3.6ii. By Figure 3.6iv,  $v$  cannot share a common 2-neighbor with a (1, 1, 0<sup>+</sup>)-vertex at distance 2 so **R2** does not apply. Hence, by **R0** and **R1**, we have

$$\mu^*(v) = \frac{3}{2} - 1 - \frac{1}{2} = 0.$$

- If  $v$  sees a (1, 1, 1)-vertex at distance 2, then  $v$  can only see exactly one such vertex. By Figure 3.6iv,  $v$  cannot have (1, 1, 0)-neighbor so **R1** does not apply. Thus, by **R0** and **R2**, we have

$$\mu^*(v) = \frac{3}{2} - 1 - \frac{1}{2} = 0.$$

- If  $v$  does not have a (1, 1, 0)-neighbor and does not see a (1, 1, 1)-vertex at distance 2, then only **R0** applies and we have

$$\mu^*(v) = \frac{3}{2} - 1 = \frac{1}{2}.$$

- Suppose  $v$  is a (0, 0, 0)-vertex.

Observe that **R0** and **R2** cannot apply since  $v$  does not have any 2-neighbor and cannot see a (1, 1, 1)-vertex at distance 2. So, only **R1** can apply and by Figure 3.6vii,  $v$  cannot have three (1, 1, 0)-neighbors. Consequently,

– If  $v$  has exactly two  $(1, 1, 0)$ -neighbors, then we have

$$\mu^*(v) = \frac{3}{2} - 2 \cdot \frac{1}{2} = \frac{1}{2}.$$

– If  $v$  has exactly one  $(1, 1, 0)$ -neighbor, then we have

$$\mu^*(v) = \frac{3}{2} - \frac{1}{2} = 1.$$

– If  $v$  has no  $(1, 1, 0)$ -neighbors, then we have

$$\mu^*(v) = \frac{3}{2}.$$

Below, we recapitulate the remaining charges of each type of 3-vertex  $v$  (as 2-vertices are at 0) after applying **R0**, **R1**, and **R2**. In Figures 3.11 to 3.17, the 2-vertices will be filled while the 3-vertices will not be.

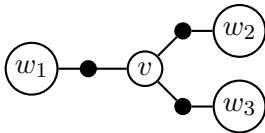

Hình 3.11:  $(1,1,1)$ .  
 $w_1, w_2, w_3 \neq (1, 1, 0^+)$ .  
 $\mu^*(v) = 0$ .

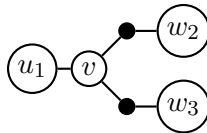

Hình 3.12:  $(1,1,0)$ .  
 $u_1 \neq (1, 1, 0)$ .  
 $w_2, w_3 \neq (1, 1, 1)$ .  
 $\mu^*(v) = 0$ .

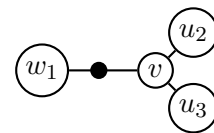

Hình 3.13:  $(1,0,0)$ .  
 $w_1 \neq (1, 1, 1)$ .  
 $u_2, u_3 \neq (1, 1, 0)$ .  
 $\mu^*(v) = \frac{1}{2}$ .

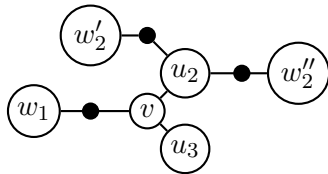

(i)  $w_1 \neq (1, 1, 0^+)$ .  
 $u_3 \neq (1, 0^+, 0)$ .

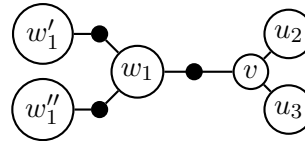

(ii)  $u_2, u_3 \neq (1, 1, 0)$ .

Hình 3.14:  $(1,0,0)$ .  
 $\mu^*(v) = 0$ .

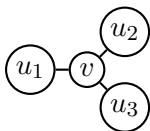

Hình 3.15:  $(0,0,0)$ .  
 $u_1, u_2, u_3 \neq (1, 1, 0)$ .  
 $\mu^*(v) = \frac{3}{2}$ .

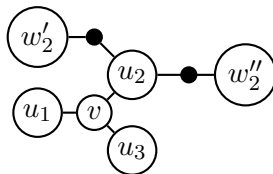

Hình 3.16:  $(0,0,0)$ .  
 $u_1, u_3 \neq (1, 1, 0)$ .  
 $\mu^*(v) = 1$ .

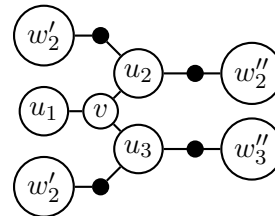

Hình 3.17:  $(0,0,0)$ .  
 $u_1 \neq (1, 1, 0)$ .  
 $\mu^*(v) = \frac{1}{2}$ .

$v \backslash \mu^*(v)$	$\frac{3}{2}$	1	$\frac{1}{2}$	0
(1,1,1)	/	/	/	fig. 3.11
(1,1,0)	/	/	/	fig. 3.12
(1,0,0)	/	/	fig. 3.13	fig. 3.14
(0,0,0)	fig. 3.15	fig. 3.16	fig. 3.17	/

Bảng 3.1: Available amount of charges for each type of 3-vertex after applying **R0-R2**.

### 3.3.2 Second round: vertices to faces

Recall that  $\mu^*(v)$  is the remaining charge of  $v$  after applying rules **R0-R2**. We define the following discharging rules between the vertices and 8-faces of  $G$ :

**R3** If a 3-vertex  $v$  is not a  $(1,0,0)$ -vertex, then it gives  $\frac{\mu^*(v)}{n_1}$  to each incident 8-face, where  $n_1$  is the number of incident 8-faces.

**R4** For a  $(1,0,0)$ -vertex  $v$ , let  $n_2$  be the number of 8-faces incident to  $v$  and to its 2-neighbor. Vertex  $v$  gives  $\frac{\mu^*(v)}{n_2}$  to each of these  $n_2$  8-faces.

Observe that  $0 \leq n_1 \leq 3$  and  $0 \leq n_2 \leq 2$ . Recall that, given a face  $f$ , the initial amount of charge is  $\mu(f) = d(f) - 9$ . So, all  $k$ -faces with  $k \geq 9$  have a positive charge. Moreover, after applying **R3-R4**, every 3-vertex  $v$  will have a remaining charge of at least  $\mu^*(v) - n_i \cdot \frac{\mu^*(v)}{n_i} = 0$  for  $1 \leq i \leq 2$ .

As a result, it remains to verify that every 8-face  $f$  will receive at least charge 1 so that its final charge will be  $\mu^*(f) \geq \mu(f) - 9 + 1 = 8 - 8 = 0$ .

To generate every possible 8-face efficiently, we introduce the following encoding of a configuration around an 8-face.

#### Encoding a face $f$ :

- For every pair of consecutive 3-vertices in clockwise order, count the number of 2-vertices in between. We obtain a circular sequence of integers in clockwise order of length equal to the number of 3-vertices of  $f$ . Since  $G$  has no  $2^+$ -threads by Lemma 3.7, each integer is in  $\{0, 1\}$ . Observe that there are at most as many ways to write this sequence of integers as the number of 3-vertices of  $f$ . Indeed, we can choose any 3-vertex  $v$  as a starting point and start counting the number of 2-vertices between  $v$  and the next 3-vertex in clockwise order. We choose as representative the first one in the lexicographic order where 1 precedes 0 and call it the *number-word* of  $f$ .

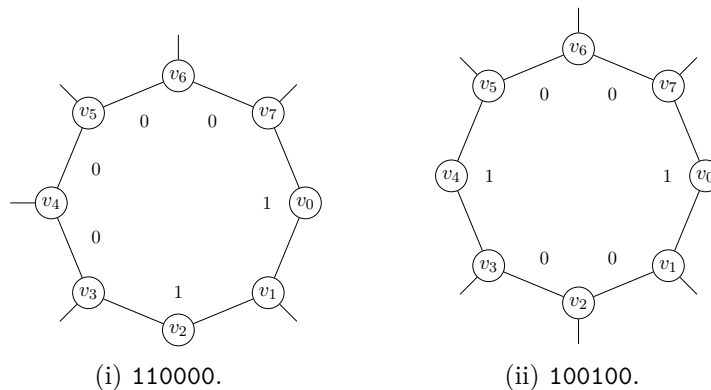

Hình 3.18: Examples of number-words on 8-faces.

Examples:

- Take the 8-face in Figure 3.18i as an example. We consider the 3-vertices in clockwise order starting at any 3-vertex, say  $v_1$ . We get  $v_1, v_3, v_4, v_5, v_6, v_7$ . Now, we count the number of 2-vertices between two consecutive vertices in that sequence. More precisely, there is one 2-vertex ( $v_2$ ) in between  $v_1$  and  $v_3$ , then none between  $v_3$  and  $v_4$ , and so on. This gives us the sequence of numbers 100001. Had we chosen another starting 3-vertex (say  $v_3$ ) we would have obtained another sequence (000011). Among all of these different sequences, we choose the one that comes first in the lexicographic order where 1 comes before 0. And that sequence is 110000, the number-word of  $f$ , which corresponds to the starting 3-vertex  $v_7$ .
- We can do the same with the 8-face in Figure 3.18ii. The number-word for  $f$  is 100100. Observe that this sequence can be obtained by taking, in clockwise order, either  $v_7$  or  $v_3$  as a starting point.
- Due to our discharging rules, we are interested in configurations around 3-vertices. So, given a 3-vertex  $v$  on  $f$ , we choose the following letters to encode the neighborhood outside  $f$  of  $v$ :
  - **c** means that  $v$  has a 2-neighbor outside  $f$ .
  - **b** means that  $v$  has a  $(1, 1, 0)$ -neighbor outside  $f$ .
  - **a** represents the rest of the possible neighbors of  $v$ . In other words, the neighbor of  $v$  outside  $f$  is a 3-vertex that is not a  $(1, 1, 0)$ -vertex.

Observe that there may be multiple starting 3-vertices that give the same number-word for  $f$ . Given one possible starting 3-vertex of the number-word  $nw$ , we insert between each pair of consecutive integers of  $nw$  the letter encoding of the neighborhood outside  $f$  of the corresponding 3-vertex. We obtain an alternating sequence  $fw$  of integers and letters for each starting 3-vertex.

Among the possible alternating sequences  $fw$ , we choose the one where the subsequence of letters is the smallest in alphabetical order. We call this alternating sequence the **full-word** of  $f$  and the corresponding subsequence of letters the **letter-word** of  $f$ .

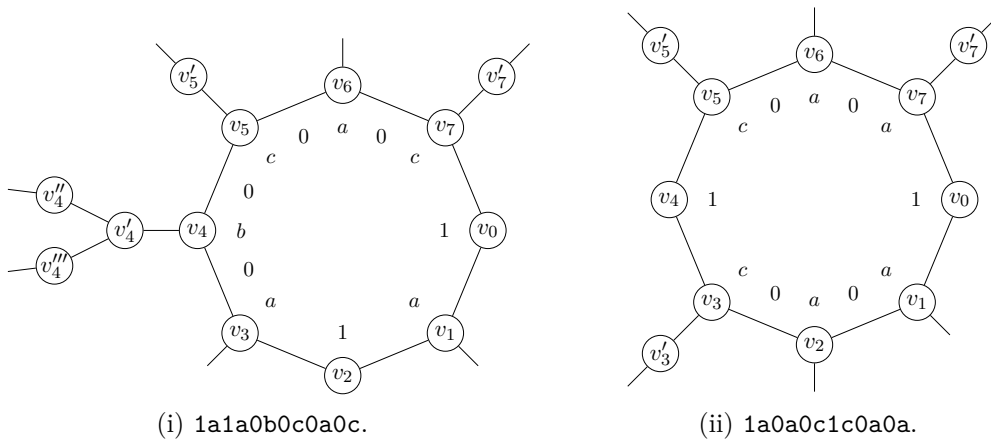

Hình 3.19: Examples of full-words on 8-faces.

Examples:

- Take the 8-face  $f$  in Figure 3.19i as an example. It is the same face as in Figure 3.18i, this time with more information about the neighborhood of the 3-vertices outside of  $f$ . Observe that when we do not have extra information about the neighborhood of a

3-vertex outside of  $f$  (it could be  $a$ ,  $b$ , or  $c$ ), we will denote it  $a$  for now and explain it later on. We consider the neighborhood of each 3-vertex, starting with the one that comes right after the first number, which is the 3-vertex  $v_1$ . In order, they corresponds to the letters  $a$ ,  $a$ ,  $b$ ,  $c$ ,  $a$ ,  $c$ , which give us the letter-word  $aabcac$ . Finally, we combine these the number-word and the letter-word into the full-word  $1a1a0b0c0a0c$ .

- We can do the same with the 8-face in Figure 3.19ii, which is the face in Figure 3.18ii with extra information. When we choose the letter-word for  $f$ , we need to consider two encodings, one that starts with the 3-vertex that comes right after  $v_7$  in clockwise order, namely  $v_1$ , or the one after  $v_3$ , namely  $v_5$ . These give us two sequence of letters  $aaccaa$  and  $caaac$  respectively. For our letter-word, we choose the first one in alphabetical order, which is  $aaccaa$ . Finally, we get the full-word  $1a0a0c1c0a0a$ .

**Observation 3.13.** Each face has a unique encoding full-word and each full-word uniquely defines a face.

Under each 8-cycle of Figures 3.7 and 3.9, you have the corresponding encoding of the reducible configuration if it were an 8-face.

In what follows we explain the generation of all possible 8-faces, how to check which ones are reducible and which ones will obtain enough charge from its incident 3-vertices by **R3** and **R4**. The corresponding pseudocode is summarized in Algorithm 1.

---

**Algorithm 1:** Filtering forbidden and dischargeable full-words corresponding to faces with a given size.

---

**Data:** forbidden\_subwords, dictionary\_of\_charges, number\_words, alphabet, target\_charge.

**Result:** The list of full-words that are not forbidden nor dischargeable.

```

1 foreach number_word ∈ number_words do
2   n = length of number_word;
3   letter_words = set of words of size n in alphabet;
4   foreach letter_word ∈ letter_words do
5     build full_word from number_word and letter_word;
6     if full_word does not contain a subword in forbidden_subwords then
7       Compute the charge of full_word using dictionary_of_charges;
8       if charge < target_charge then
9         Write full_word to output;
10      end
11    end
12  end
13 end

```

---

Since  $G$  has no  $2^+$ -threads and  $f$  has length 8, there can be at most four 2-vertices on  $f$ . On the other hand, given a number-word  $nw$  of  $f$ , the number of 2-vertices of  $f$  is given by the number of 1s in  $nw$ . Therefore, one can easily check the following observation:

**Observation 3.14.** The only possible number-words for 8-faces in  $G$  are 1111, 11100, 11010, 110000, 101000, 100100, 1000000, and 00000000.

Since the process of generating these number-words is done naively and it is not the main focus of the algorithm, we will not go into technical details. However, the script is available at <https://gite.lirmm.fr/discharging/planar-graphs>. For this case, the set of number-words is small enough that it can even be checked manually.

Now, for each number-word  $nw$ , we can generate all possible sequences of letters in  $\{a, b, c\}$  with the same length as  $nw$  that we will then interlace with  $nw$  to create an alternating sequence

corresponding to a full-word (line 5 of Algorithm 1). Observe that during this process of generation, we may obtain several words representing the same face and only one of them is the unique full-word encoding  $f$ . This has no influence on the correctness of our algorithm, only on the time complexity, as some faces might be checked multiple times. Here, it is possible to identify the symmetries in the generated words in order to keep the unique full-words. However, in practice, at least for our case, this subroutine adds complications with minimal time gain.

The list of full-words described above corresponds to all possible neighborhoods at distance at most 2 of an 8-face. We filter out every neighborhood that either contains a reducible configuration (line 6 of Algorithm 1), or has enough charge available for its 8-face by **R3** and **R4** (line 8 of Algorithm 1).

In order to check that the corresponding subgraph of a full-word contains a reducible configuration, we encode the latter using similar conventions as for the neighborhood of the 8-faces. Indeed, the considered configuration is encoded as seen from an incident face. Thus, one configuration may have multiple different encodings (depending on the incident faces) and we call these encodings **forbidden subwords**. A full-word that contains a forbidden subword is **forbidden**.

Since we always consider the worst case scenario, if a forbidden subword contains a letter **a**, then one can always build two other (“weaker”) forbidden subwords by replacing this **a** by **b** or **c**. Therefore, whenever we consider a forbidden subword containing **a**, we also implicitly consider the other “weaker” subwords. See Figures 3.6 to 3.8 where the captions contain all possible forbidden (“strong”) subwords of each reducible configuration. In a general case, one can define a different symbol (another letter, say  $d$  for example) that can be rewritten as multiple different letters (here **a**, **b**, and **c**). Our choice was **a** for simplicity.

In the code implementation of Algorithm 1, we define a forbidden subword as a regular expression and rewriting rule (formal grammar) in which **a** can be rewritten as **b** or **c**.

**Observation 3.15.** In a forbidden subword, **a** can mean **a**, **b**, or **c** in a real encoding.

Now, recall that a full-word is actually circular and is read in clockwise order. Thus, in order to check whether it is forbidden, one has to check if it contains a forbidden subword or its mirror. Once we removed the forbidden subword, we are ready to move on to the next step of the algorithm.

The next step (lines 7-8 of Algorithm 1) is to check, for every full-word  $fw$ , whether the 3-vertices of the corresponding subgraph give enough charge to  $f$  according to **R3** and **R4** (at least a total charge 1). If it is the case, then we say that  $fw$  is **dischargeable**. Similar to the encoding of the reducible configurations, we can also encode into a dictionary the configurations from Figures 3.11 to 3.17. The encoding of each entry of the dictionary corresponds to a possible neighborhood of a 3-vertex, along with  $\frac{\mu^*(v)}{3}$  for the worst case scenario in **R3** (Figures 3.11, 3.12 and 3.15 to 3.17) and  $\frac{\mu^*(v)}{2}$  for **R4** (Figures 3.13 and 3.14). To work with integers, we multiply by 12 the charge of each vertex and each face of  $G$ . In Table 3.2, we detail the dictionary entries for each configuration.

fig. 3.11	fig. 3.12	fig. 3.13	fig. 3.14i	fig. 3.14ii	fig. 3.15	fig. 3.16	fig. 3.17
1c1 : 0	1a1 : 0	1a0 : 3	1b0 : 0	0a1c1 : 0	0a0 : 6	0b0 : 4	0b0c1 : 2
	1c0 : 0	0c0 : 0	1a0c1 : 0			0a0c1 : 4	1c0a0c1 : 2

Bảng 3.2: The dictionary of charges. Each entry is written as “<encoding> : <charge>”. Every value was multiplied by 12 to get an integer.

Observe that, in our case, every encoding in a dictionary entry starts and ends with a number. Thus, we have the following observation.

**Observation 3.16.** The encoding in a dictionary entry always has odd length.

As a consequence, the 3-vertex  $v$  that holds the charge in the encoding of a dictionary entry corresponds to:

- either the letter in the middle when it has length 3 or 7,
- or the letter in second position when it has length 5.

Once again, each encoding can be read from left to right or right to left. Note that one has to be mindful of the position of  $v$  when reading an encoding of length 5 from right to left.

In order to count the total amount of charge that an 8-face will receive from its 3-vertices, the algorithm consists of sliding a window of odd length across the circular full-word. We start with the window of the largest possible length (7 according to our dictionary) in order to have the most information about the neighborhood of  $v$ . At each step, it searches for the corresponding encoding (or its mirror) in the dictionary and if it exists, it marks the position as “discharged” and adds the corresponding amount of charge to its total amount. For a given window size, if the corresponding subword is not in the dictionary, then it means that the dictionary entry corresponding to  $v$  must have an encoding of smaller length (recall that the dictionary entries are exhaustive). Then, it suffices to verify that the total amount is at least 12 (`target_charge`) since we multiplied every charge by 12. In such a case, we know that our 8-face will end up with a non-negative amount of charge.

### 3.3.3 Third round: faces to faces

We ran Algorithm 1 to compute the outcome of the second round of discharging. The only remaining type of face which was output by the algorithm corresponds to the face  $f$  in Figure 3.20 with full-word 1c1a0a1a0a. We define another discharging rule **R5** to take care of this last case.

**R5** Let  $f$  and  $f'$  be as depicted in Figure 3.20. If  $f'$  is an 8-face, then  $f'$  gives  $\frac{1}{2}$  to  $f$ .

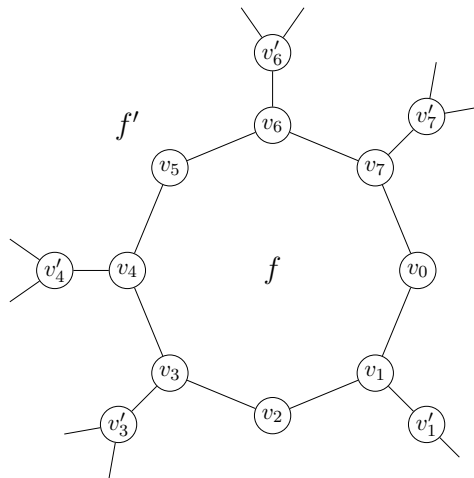

Hình 3.20:  $v'_3, v'_4, v'_6, v'_7 \neq (1, 1, 0)$ .

We show that after applying **R5**, we get  $\mu^*(f) \geq 0$  and  $\mu^*(f') \geq 0$ . Recall that 8-faces have starting charge  $-1$ .

First of all, by Figure 3.13 and **R4**, if  $f'$  is not an 8-face, then  $v_4$  and  $v_6$  each give  $\frac{1}{2}$  to  $f$ . So,

$$\mu^*(f) \geq -1 + 2 \cdot \frac{1}{2} = 0.$$



If  $f'$  is an 8-face, then  $v_4$  and  $v_6$  each give  $\frac{1}{4}$  to  $f$  by Figure 3.13 and **R4**, and  $f'$  gives  $f$   $\frac{1}{2}$  by **R5**. Thus,

$$\mu^*(f) \geq -1 + 2 \cdot \frac{1}{4} + \frac{1}{2} = 0.$$

Now, let us show that  $\mu^*(f') \geq 0$ . We know that  $f'$  is an 8-face so  $\mu(f') = -1$  and  $f'$  gives  $\frac{1}{2}$  to  $f$  by **R5**.

Let  $f' = v'_4 v_4 v_5 v_6 v'_6 v''_6 v_8 v''_4$ . By Figure 3.10iii,  $v'_4$  cannot be a 2-vertex so it must be a 3-vertex. Symmetrically,  $v''_6$  must also be a 3-vertex. By Figure 3.10ii,  $v_8$  must also be a 3-vertex. Observe that **R5** can thus only apply once to  $f'$ . Let  $u''_4$ ,  $u''_6$ , and  $u_8$  be the neighbors that do not lie on  $f'$  of  $v'_4$ ,  $v''_6$ , and  $v_8$  respectively.

Observe that  $v_4$  and  $v_6$  each give  $\frac{1}{4}$  to  $f'$  by Figure 3.13 and **R4**. Moreover, since  $v'_4$  cannot have a 2-neighbor by Figure 3.10iii,  $v'_4$  gives at least  $\frac{1}{3}$  to  $f'$  by Figures 3.15 and 3.16 and **R3**. Symmetrically, the same holds for  $v''_6$ . We conclude with the following cases:

- If  $u''_4$  (or  $u''_6$ ) is a 3-vertex, then  $v'_4$  (or  $v''_6$ ) gives at least  $\frac{1}{3}$  to  $f'$  by Figures 3.15 and 3.16 and **R3**. To sum up,

$$\mu^*(f') \geq -1 - \frac{1}{2} + 2 \cdot \frac{1}{4} + 3 \cdot \frac{1}{3} = 0.$$

- If  $u''_4$  and  $u''_6$  are 2-vertices, then  $u_8$  must be a 3-vertex by Figure 3.10i. In that case,  $v_8$  gives at least  $\frac{1}{3}$  to  $f'$  by Figures 3.15 and 3.16 and **R3**. To sum up,

$$\mu^*(f') \geq -1 - \frac{1}{2} + 2 \cdot \frac{1}{4} + 3 \cdot \frac{1}{3} = 0.$$

To conclude, we started with a negative total amount of charge on the vertices and faces of  $G$  by Equation (3.1) and after our discharging procedures, which preserve the total amount of charge, we ended up with a non-negative amount of charge on each vertex and face of  $G$ . This is a contradiction, so  $G$  does not exist and this ends the proof of Theorem 3.1.

### 3.4 Generalization of the discharging algorithm

---

In Section 3.3.2, we presented an algorithm (Algorithm 1) that automates the discharging procedure with a given set of reducible configurations. This becomes extremely helpful for proofs where the discharging procedure involves a large case analysis. For the input we efficiently encode a face, the set of reducible configurations, as well as the amount of charge of a vertex depending on its neighborhood. The corresponding computer program was written in Python 3.7. The source code and its documentation is publically available on <https://gite.lirmm.fr/discharging/planar-graphs>. In the case of Theorem 3.1, the execution time takes few seconds on a standard machine. In order to show how to use our computer program, we provide another example on the public repository proving the 2-distance 8-choosability of planar graphs with maximum degree 4 and girth at least 7, one of the results by Cranston *et al.* in [36].

Our approach can be applied to other problems on planar graphs by concentrating charges on the vertices of the graph when the distribution of charges is made (according to the Euler formula). First, one can try to obtain a non-negative sum of charges on the vertices (by realizing an easy discharging procedure for example). This concentrates the difficulty of the problem on the second round of discharging. In that round, one has to redistribute the remaining charge of the vertices to the faces with negative charge and that is where our algorithm can come in handy. Note that the way our algorithm is designed, a vertex can also take charge from a face by giving it a negative charge.

The encoding of a face with a number-word and a letter-word can be done in the same way. In our case, since  $G$  has no  $2^+$ -threads, the number-word of a face is composed of integers in  $\{0, 1\}$ . But this alphabet can be extended to  $\{0, 1, \dots, k-1\}$  if  $G$  has no  $k^+$ -threads. Observe that one

can partition a face into  $i$ -threads ( $0 \leq i \leq k - 1$ ) and consider that each thread contains only one endvertex. Therefore, in order to obtain the starting number-words for a face of size  $d(f)$ , it suffices to decompose  $d(f)$  into sums where each term corresponds to the number of vertices in an  $i$ -thread. As for the letter-words, it suffices to choose a letter for each different neighborhood of interest outside the considered face. In our case, three letters are sufficient but one can always work with a larger alphabet to suit the considered problems. Once the convention for the encoding of a face is fixed, the reducible configurations and entries of the dictionary of charges can be done in the same way.

There are a few details to note about the entries of the dictionary. First, the position of the vertex  $v$  holding the charge must be in the center of the entry (or just left of the center). Second, the encoding has to start and end with a number. These properties can be guaranteed by extending the encoding with every possible sequence up to a certain length. Finally, one has to be mindful that  $v$  is in the center when the length of the encoding is congruent to 3 modulo 4, and left of the center when it is congruent to 1 modulo 4.

Moreover, we would like to note that, when a discharging procedure along with the given reducible configurations do not prove the desired result, Algorithm 1 returns a sufficient set of missing configurations (to be reduced). This helps to pinpoint the possible difficulty of the proof using the discharging method. In practice, start with a simple discharging procedure and reduce the missing configurations returned by Algorithm 1. If there are non-reducible configurations left, then refine the discharging procedure. Repeat the process until a sufficient set of discharging rules and reducible configurations is reached. In particular, this is how we obtained the reducible configurations in the proof of Theorem 3.1. In that sense, Algorithm 1 is not only a tool to verify a proof but also a tool to assist the research process.

## Chương 4

# Building planar graphs with high $g$ and $\chi^2$

Most of the research done in 2-distance coloring of planar graphs with high girth (Table 1.1) have been focused on providing upper bounds on  $g_0$  or  $\Delta_0$  for the following questions.

**Question 4.1.** For a given constant  $c_0$  and  $\Delta_0$  (resp.  $g_0$ ), what is the smallest  $g_0$  (resp.  $\Delta_0$ ) such that every planar graph  $G$  with  $g(G) \geq g_0$  and  $\Delta(G) \geq \Delta_0$  verifies  $\chi^2(G) \leq \Delta(G) + c_0$ ?

However, there is also another approach to Question 4.1, that is to find lower bounds on  $g_0$  (resp.  $\Delta_0$ ) for a fixed  $\Delta_0$  (resp.  $g_0$ ). These bounds are obtained from constructions with high girth and high 2-distance chromatic number. Apart from some small graphs initially provided by Wegner, there are few other constructions improving those lower bounds. That shows that we still lack a deep understanding of the behaviors of 2-distance colorings despite the simplicity in its concept.

**Proposition 4.2** (Dvořák *et al.* [51]). For every integer  $d \geq 2$ , there exists a planar graph  $G$  with  $g(G) = 6$ ,  $\Delta(G) = d$ , and  $\chi^2(G) \geq d + 2$ .

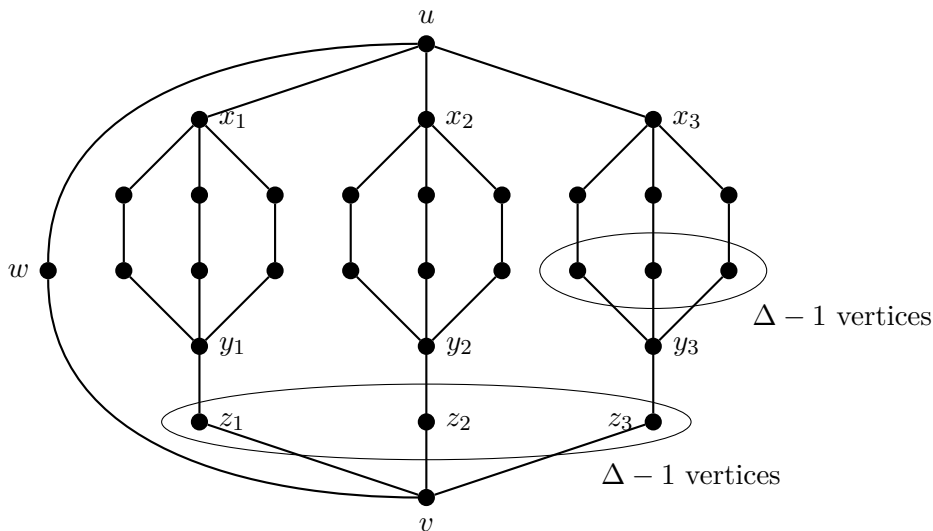

Hình 4.1: A graph with girth 6 and  $\chi^2 \geq \Delta + 2$  (drawn for  $\Delta = 4$ ) [51].

To match these efforts in finding graphs with high girth and high 2-distance chromatic number, we proved the following negative results.

**Proposition 4.3** ([87]). There exists a planar graph  $G$  with  $g(G) \geq 4$  and  $\chi^2(G) \geq \Delta(G) + 3$ .

**Proposition 4.4** ([87]). There exists a planar graph  $G$  with  $g(G) \geq 5$ ,  $\Delta(G) = 4$ , and  $\chi^2(G) \geq \Delta(G) + 3$ .

**Proposition 4.5** ([84]). There exists a planar graph  $G$  with  $g(G) \geq 11$ ,  $\Delta(G) = 3$ , and  $\chi^2(G) \geq \Delta(G) + 2$ .

**Proposition 4.6** ([90]). There exists a planar graph  $G$  with  $g(G) \geq 6$ ,  $\Delta(G) = 3$ , and  $\chi^2(G) \geq \Delta(G) + 3$ .

The graphs in Propositions 4.3 to 4.4 are provided in Figure 4.2(i) and (ii) respectively.

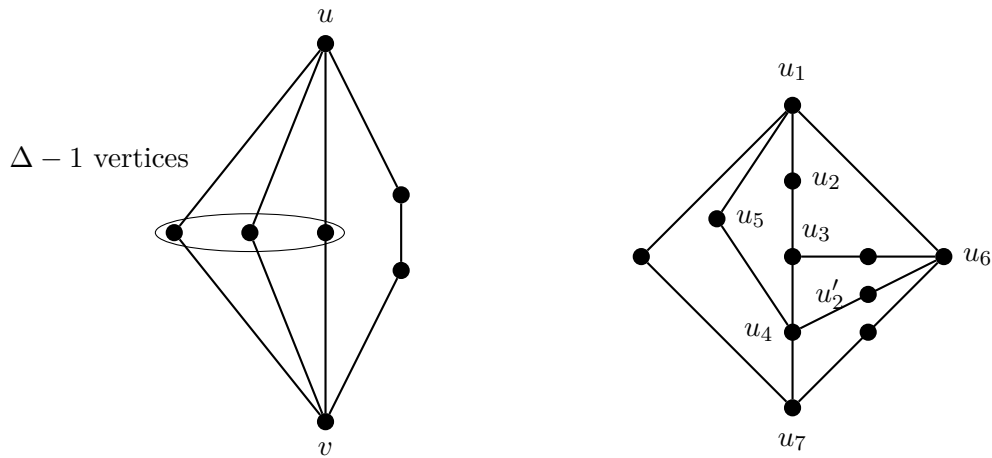

(i) A graph with girth 4 and  $\chi^2 \geq \Delta + 3$ .

(ii) A graph with  $\Delta = 4$ , girth 5, and  $\chi^2 \geq 7$ .

Hình 4.2: Graphs with  $\chi^2 \geq \Delta + 3$ .

## Building a non 4-colorable subcubic planar graph of girth 11

In [52], Dvořák *et al.* presented a non 4-colorable, planar, and subcubic graph with girth at least 9. The main building block of that graph relies upon an interesting property of 4-colorings of paths of length 5. Using the same property we managed to build a non 4-colorable planar subcubic graph of girth 11.

**Lemma 4.7.** Let  $H$  be a subcubic graph of girth at least 11 and  $\phi$  a 4-coloring of  $H$ . Let  $u_1u_2u_3u_4u_5u_6$  be a path of length 5 in  $H$ , if  $\phi(u_1) = \phi(u_6)$ , then  $\phi(u_2) = \phi(u_5)$ .

*Chứng minh.* Since  $H$  has girth at least 11, all vertices are distinct (see Figure 4.3). Suppose by contradiction that  $\phi(u_1) = \phi(u_6)$  but  $\phi(u_2) \neq \phi(u_5)$ . W.l.o.g. we set  $\phi(u_1) = \phi(u_6) = a$ ,  $\phi(u_2) = b$ , and  $\phi(u_5) = c$ . Since  $u_3$  sees  $u_1$ ,  $u_2$ , and  $u_5$ , colored respectively  $a$ ,  $b$ , and  $c$ , it must be colored  $d$ . Finally,  $u_4$  sees  $u_2$ ,  $u_3$ ,  $u_5$ , and  $u_6$ , colored respectively by  $b$ ,  $d$ ,  $c$ , and  $a$ . Thus,  $u_4$  is non-colorable, which is a contradiction since  $\phi$  is a 4-coloring of  $H$ .  $\square$

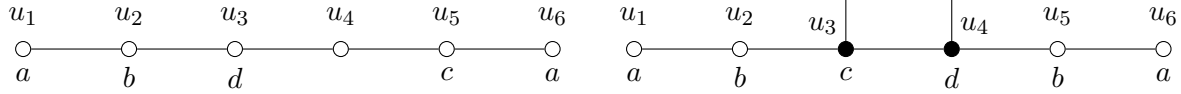

Hình 4.3: A non-valid coloring of  $H$  in Lemma 4.7.

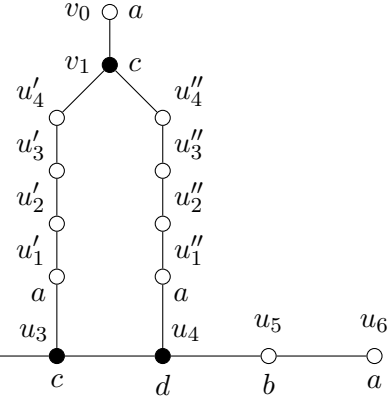

Hình 4.4: A non-valid coloring of  $H$  in Lemma 4.8.

**Lemma 4.8.** Let  $H$  be a subcubic graph of girth 11 and  $\phi$  a 4-coloring of  $H$ . Let  $u_1u_2u_3u_4u_5u_6$ ,  $u_3u'_1u'_2u'_3u'_4v_1$ ,  $u_4u''_1u''_2u''_3u''_4v_1$  be paths of length 5 in  $H$ . Let  $v_0 \notin \{u'_4, u''_4\}$  be adjacent to  $v_1$ . If  $\phi(u_1) = \phi(u_6) = \phi(v_0)$ , then  $\phi(u_2) = \phi(u_5) = \phi(v_1)$ .

*Chứng minh.* Since  $H$  has girth 11, all vertices are distinct (see Figure 4.4). We assume w.l.o.g. that  $\phi(u_1) = \phi(u_6) = \phi(v_0) = a$ . By Lemma 4.7, since  $\phi(u_1) = \phi(u_6)$ , we must have  $\phi(u_2) = \phi(u_5)$ . W.l.o.g. we set  $\phi(u_2) = \phi(u_5) = b$ . As a result, we have  $\{\phi(u_3), \phi(u_4)\} = \{c, d\}$ . We assume w.l.o.g. that  $\phi(u_3) = c$  and  $\phi(u_4) = d$ . Now, suppose by contradiction that  $\phi(v_1) = c$ . By Lemma 4.7, since  $\phi(u_3) = \phi(v_1)$ , we must have  $\phi(u'_1) = \phi(u'_4) = a$ . However, this is impossible since  $u'_4$  sees  $v_0$  which is colored  $a$ . By symmetry, the same argument holds when  $\phi(v_1) = d$ . Finally, since  $v_1$  also sees  $v_0$ , thus  $\phi(v_1) \notin \{a, c, d\}$ , and so  $\phi(v_1) = b = \phi(u_2) = \phi(u_5)$ .  $\square$

**Lemma 4.9.** The graph  $G_{\neq}(u, v)$  in Figure 4.5i has the following properties:

- $G_{\neq}(u, v)$  is planar and subcubic.
- $G_{\neq}(u, v)$  has girth 11.
- The distance in  $G_{\neq}(u, v)$  between  $u$  and  $v$  is 7.
- Every 4-coloring  $\phi$  of  $G_{\neq}(u, v)$  satisfies  $\phi(u) \neq \phi(v)$ .

*Chứng minh.* One can verify that  $G_{\neq}(u, v)$  is planar, subcubic, has girth 11, and that the distance between  $u$  and  $v$  is 7 thanks to Figure 4.5i. It remains to prove that  $\phi(u) \neq \phi(v)$  for every 4-coloring  $\phi$  of  $G_{\neq}(u, v)$ .

Suppose by contradiction that there exists a 4-coloring  $\phi$  such that  $\phi(u) = \phi(v) = a$ . We can assume w.l.o.g. that  $\phi(u_1) = b$ ,  $\phi(u_2) = c$ , and  $\phi(v_5) = d$ . Since  $u_6$  sees  $v$  which is colored  $a$ , we distinguish the following cases based on  $\phi(u_6)$ :

- If  $\phi(u_6) = b$ , then  $\phi(u_5) = \phi(u_2) = c$  by Lemma 4.7 as  $\phi(u_6) = \phi(u_2)$ . As a result,  $\phi(v_1) = d$ . Since  $v_2$  and  $v_4$  both see  $b$  and  $d$ , we have  $\{\phi(v_2), \phi(v_4)\} = \{a, c\}$ . Now,  $v_3$  sees  $\{\phi(v_1), \phi(v_2), \phi(v_4), \phi(v_5)\} = \{d, a, c\}$ , so  $\phi(v_3) = b$ . Finally,  $v_7$  sees  $\{\phi(v_2), \phi(v_3), \phi(v_4)\} = \{a, b, c\}$ , hence  $\phi(v_7) = d$ . However, this is impossible since  $\phi(u_1) = \phi(u_6) = \phi(v_3) = b$ , thus  $\phi(u_2) = \phi(u_5) = \phi(v_7) = c$  by Lemma 4.8.
- If  $\phi(u_6) = c$ , then we have the two following cases:

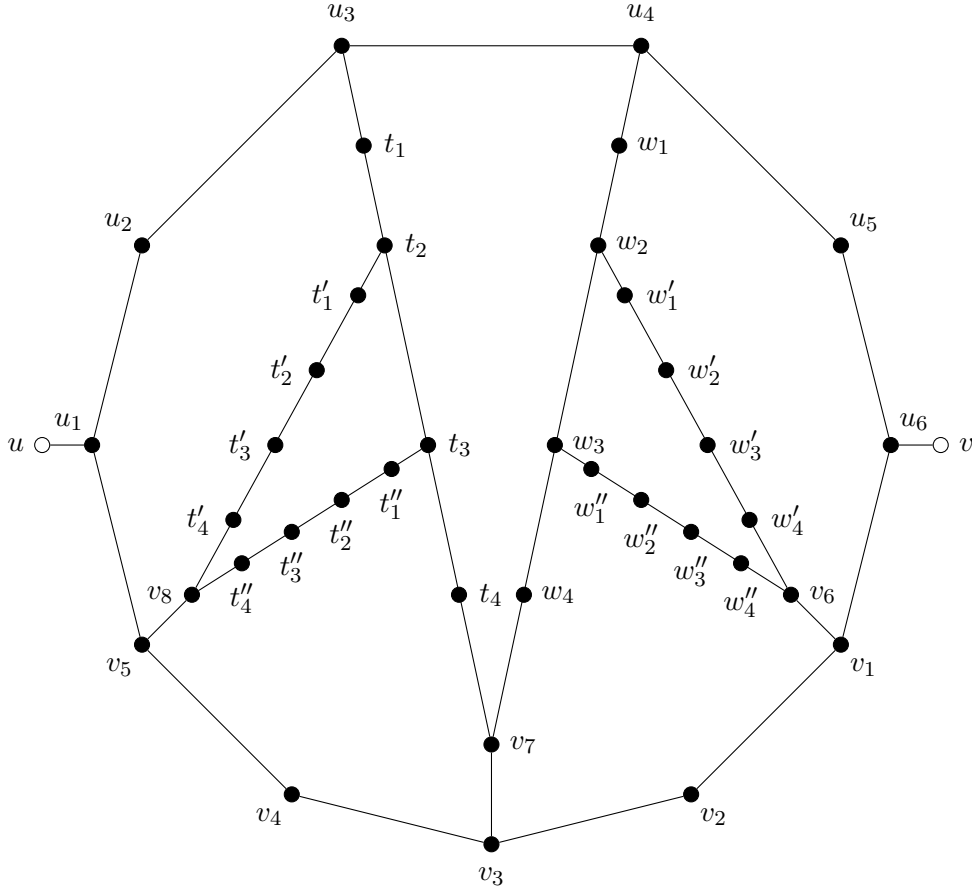

(i) The gadget  $G_{\neq}(u, v)$  in Lemma 4.9.



(ii) Simplified drawing of  $G_{\neq}(u, v)$ .

Hình 4.5:  $G_{\neq}(u, v)$ .

- If  $\phi(v_1) = b$ , then  $\phi(v_2) = \phi(v_5) = d$  by Lemma 4.7 as  $\phi(v_1) = \phi(u_1)$ . As a result,  $\phi(u_5) = d$  and  $\phi(v_6) = a$ . Since  $v_3$  and  $v_4$  both see  $b$  and  $d$ , we have  $\{\phi(v_3), \phi(v_4)\} = \{a, c\}$ . Now,  $v_7$  sees  $\{\phi(v_2), \phi(v_3), \phi(v_4)\} = \{d, a, c\}$ , so  $\phi(v_7) = b$ . Since  $u_3$  sees  $b, c$ , and  $d$ ,  $\phi(u_3) = a$  and consequently,  $\phi(u_4) = b$  and  $\phi(w_1) = c$ . However, this is impossible since  $\phi(u_4) = \phi(v_7) = \phi(v_1) = b$ , thus  $\phi(w_1) = \phi(w_4) = \phi(v_6) = a$  by Lemma 4.8.
- If  $\phi(v_1) = d$ , then  $\phi(u_5) = b$ . Since  $v_2, v_3$ , and  $v_4$  all see  $d$ ,  $\{\phi(v_2), \phi(v_3), \phi(v_4)\} = \{a, b, c\}$ . As a result,  $\phi(v_7) = d$ . Both  $u_3$  and  $u_4$  see  $b$  and  $c$ , so  $\{\phi(u_3), \phi(u_4)\} = \{a, d\}$ . Since  $w_1$  sees  $\{\phi(u_3), \phi(u_4), \phi(u_5)\} = \{a, d, b\}$ ,  $\phi(w_1) = c$ . Due to Lemma 4.8, we must have  $\phi(u_4) = a$ . Otherwise,  $\phi(u_4) = d = \phi(v_7) = \phi(v_1)$  and  $\phi(w_1) = \phi(w_4) = \phi(v_6) = c$  which is impossible since  $v_6$  sees  $u_6$  colored  $c$ . Thus,  $\phi(u_3) = d$  and  $\phi(t_1) = b$ . However, this is also impossible since  $\phi(u_3) = \phi(v_7) = \phi(v_5) = d$ , thus  $\phi(t_1) = \phi(t_4) = \phi(v_8) = b$  by Lemma 4.8 and  $v_8$  sees  $u_1$  colored  $b$ .
- If  $\phi(u_6) = d$ , then  $\phi(v_1) = \phi(v_4)$  by Lemma 4.7 as  $\phi(u_6) = \phi(v_5)$ . Since  $v_4$  sees  $b$  and  $d$  and  $v_1$  sees  $a$  and  $d$ ,  $\phi(v_4) = \phi(v_1) = c$ . As a result,  $\phi(u_5) = b$  and  $\phi(v_8) = a$ . Both  $v_2$  and  $v_3$  see  $c$  and  $d$ , so  $\{\phi(v_2), \phi(v_3)\} = \{a, b\}$ . Now,  $v_7$  sees  $\{\phi(v_2), \phi(v_3), \phi(v_4)\} = \{a, b, c\}$ , so  $\phi(v_7) = d$ . Since  $u_4$  sees  $d, b$ , and  $c$ ,  $\phi(u_4) = a$  and consequently,  $\phi(u_3) = d$  and  $\phi(t_1) = b$ . However, this is impossible since  $\phi(u_3) = \phi(v_7) = \phi(v_5) = d$ , thus  $\phi(t_1) = \phi(t_4) = \phi(v_8) = a$  by Lemma 4.8.

□

**Lemma 4.10.** The graph  $G'_{\neq}(u, v)$  in Figure 4.6i has the following properties:

- $G'_{\neq}(u, v)$  is planar and subcubic.
- $G'_{\neq}(u, v)$  has girth 11.
- The distance in  $G'_{\neq}(u, v)$  between  $u$  and  $v$  is 10.
- Every 4-coloring  $\phi$  of  $G'_{\neq}(u, v)$  satisfies  $\phi(u) \neq \phi(v)$ .

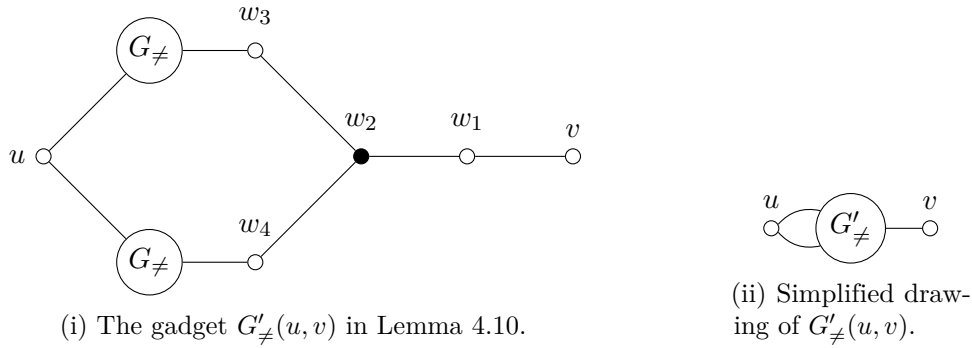

Hình 4.6:  $G'_{\neq}(u, v)$ .

*Chứng minh.* One can verify that  $G'_{\neq}(u, v)$  is planar, subcubic, has girth 11, and that the distance between  $u$  and  $v$  is 10 thanks to Figure 4.6i and Lemma 4.9. It remains to prove that  $\phi(u) \neq \phi(v)$  for every 4-coloring  $\phi$  of  $G'_{\neq}(u, v)$ . Suppose by contradiction that there exists a 4-coloring  $\phi$  of  $G'_{\neq}(u, v)$  such that  $\phi(u) = \phi(v)$ , say  $\phi(u) = a$ . We only need to observe that  $w_3$  and  $w_4$  cannot be colored  $a$  thanks to  $G_{\neq}(u, v)$  and  $w_1$  and  $w_2$  cannot be colored  $a$  since they see  $v$ . This is a contradiction as we have four vertices at distance two pairwise but only three colors left.  $\square$

**Lemma 4.11.** The graph  $G_{=}(u, v)$  in Figure 4.7i has the following properties:

- $G_{=}(u, v)$  is planar and subcubic.
- $G_{=}(u, v)$  has girth 11.
- The distance in  $G_{=}(u, v)$  between  $u$  and  $v$  is 3.
- Every 4-coloring  $\phi$  of  $G_{=}(u, v)$  satisfies  $\phi(u) = \phi(v)$ .

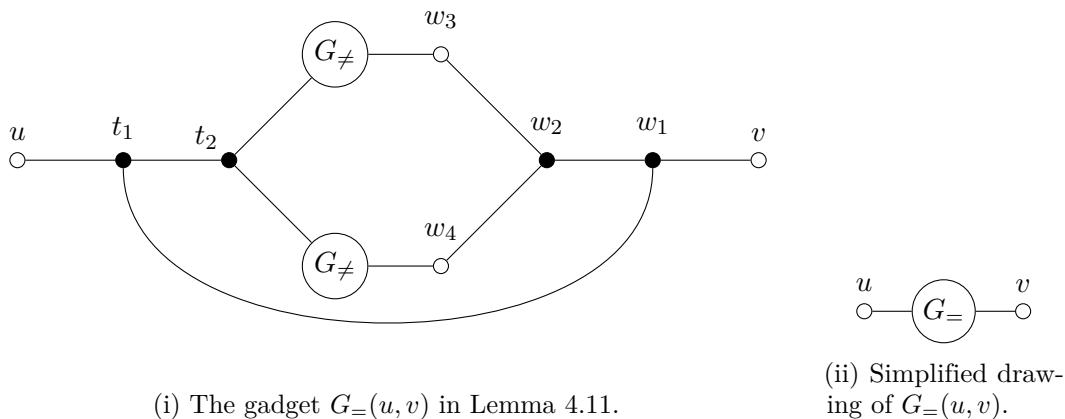

Hình 4.7:  $G_{=}(u, v)$ .

*Chứng minh.* One can verify that  $G_{=}(u, v)$  is planar, subcubic, has girth 11, and that the distance between  $u$  and  $v$  is 3 thanks to Figure 4.7i and Lemma 4.11. It remains to prove that  $\phi(u) = \phi(v)$  for every 4-coloring  $\phi$  of  $G_{=}(u, v)$ . Let  $\phi$  be a 4-coloring of  $G_{=}(u, v)$ , we can assume w.l.o.g. that  $\phi(u) = a$ ,  $\phi(t_1) = b$ ,  $\phi(t_2) = c$ , and  $\phi(w_1) = d$ . Observe that  $v$  sees  $t_1$  and  $w_1$  colored respectively  $b$  and  $d$ . Moreover, due to Lemma 4.10,  $\phi(v) \neq \phi(t_2) = c$  as  $G_{=}(u, v)$  contains  $G'_{\neq}(t_2, v)$ . As a result, we must have  $\phi(v) = a = \phi(u)$ .  $\square$

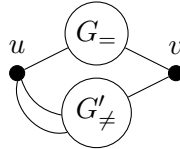

Hình 4.8: A non-4-colorable planar subcubic graph of girth 11.

As a direct consequence of Lemma 4.10 and Lemma 4.11, we get the following lemma.

**Lemma 4.12.** The graph  $G$  in Figure 4.8 is a planar subcubic graph of girth 11 with  $\chi^2(G) \geq 5$ .

In [52], the authors also proved the NP-completeness of the problem of deciding if a planar subcubic graph of girth 9 is 4-colorable using a gadget that can reproduce colors at a far enough distance to preserve the girth condition. The same proof can be adapted directly to prove the NP-completeness of deciding if a planar subcubic graph of girth 11 is 4-colorable by using a concatenation of  $G_{=}(u, v)$  to get a large enough distance. This fact also points out the difficulty of characterizing planar graphs that are 2-distance colorable (for a given number of colors) even when we have restrictions on its maximum degree and girth.

The behaviors of 2-distance colorings that we have observed in this chapter raise an interesting question concerning the plausibility of Conjecture 1.10. Indeed, given a maximum degree, the number of vertices of a planar graph of diameter 2 is bounded and Conjecture 1.10 comes from an intuition on that maximum number of vertices. These intuitions were confirmed by Fellows *et al.* [56] who proved Conjecture 1.10 for planar graphs with diameter at most 2 and  $\Delta \geq 8$  and by Dai *et al.* [42] who proved the conjecture for the remaining cases ( $\Delta < 8$ ). Thus, one might believe that Conjecture 1.10 indicates that the conflicts and difficulties in 2-distance coloring do not come from vertices that are far away from each other but rather neighborhoods with a small diameter. This intuition seems to be false as we have seen, in this chapter, that it is possible to create conflicts between vertices at arbitrary distance.

At the same time, the conjectured bounds could be the right threshold where there are enough colors for the problem to become easy. To illustrate this phenomenon more clearly, a comparison with proper coloring can be drawn. Indeed, the maximum number of vertices in a planar graph with diameter 1 is 4, which is also the sufficient amount of colors to color any planar graph properly by the Four Color Theorem. However, the problem of deciding if a planar graph is 3-colorable becomes NP-complete. So, one might believe that the same type of results holds for 2-distance coloring. More precisely, for a given maximum degree, the maximum number of vertices in a planar graph with diameter 2 can also be the sufficient amount of colors to 2-distance color a planar graph of any diameter, but the decision problem on  $\chi^2$  is NP-complete when we are below that threshold. This is already proven for planar subcubic graphs. Indeed, the maximum number of vertices in a planar subcubic graph of diameter 2 is 7, which is also the sufficient amount of colors to 2-distance color any planar subcubic graphs [114, 66]. However, as we have seen in this chapter, the problem of deciding if a planar subcubic graphs is 4-colorable becomes NP-complete even when we are restricted to graphs with high girth.



# Chương 5

## Other variants of 2-distance coloring

In this chapter, we present some works that have been done on other variants of 2-distance coloring, namely  $r$ -hued coloring, injective coloring, and exact square coloring.

### 5.1 $r$ -hued coloring

The “2-distance constraint” in 2-distance colorings requires that vertices at distance at most two have different colors. In other words, all neighbors of the same vertex must have different colors. This condition was generalized recently and the notion of  $r$ -hued coloring was introduced by Montgomery [98]. Let  $r, k \geq 1$  be two integers. An  $r$ -hued  $k$ -coloring (also called  $r$ -dynamic  $k$ -coloring in the literature) of the vertices of  $G$  is a proper  $k$ -coloring of the vertices, such that all vertices are  $r$ -hued. A vertex is  $r$ -hued if the number of colors in its neighborhood  $N_G(v) = \{x | xv \in E\}$  is at least  $\min\{d_G(v), r\}$ . The  $r$ -hued chromatic number of  $G$ , denoted  $\chi_r(G)$ , is the smallest integer  $k$  so that  $G$  has an  $r$ -hued  $k$ -coloring.

It is indeed a generalization of 2-distance colorings which corresponds to the case  $r \geq \Delta$ , as all vertices in the same neighborhood will have different colors. More generally, its link to proper coloring and 2-distance coloring resides in the following equation:

$$\chi(G) = \chi_1(G) \leq \chi_2(G) \leq \dots \leq \chi_\Delta(G) = \chi_{\Delta+1}(G) = \dots = \chi^2(G) \quad (5.1)$$

Examples of  $r$ -hued colorings are given in Figure 5.1.



(i) A 2-hued 5-coloring which is not a 2-distance coloring.

(ii) A 5-hued 6-coloring which is also a 2-distance coloring.

Hình 5.1: The vertices are labeled with their color.

Similar to the 2-distance chromatic number, the  $r$ -hued chromatic number is linear in  $r$  when it comes to planar graphs. In 2014, Song *et al.* proposed a generalization of Conjecture 1.10:

**Conjecture 5.1** (Song *et al.* [108]). Let  $G$  be a planar graph. Then,

$$\chi_r(G) \leq \begin{cases} r + 3, & \text{if } 1 \leq r \leq 2, \\ r + 5, & \text{if } 3 \leq r \leq 7, \\ \lfloor \frac{3r}{2} \rfloor + 1, & \text{if } r \geq 8. \end{cases}$$

One can note that the case  $r = 1$  corresponds to the Four Color Theorem [3, 4] ; additionally, by taking  $r = \Delta(G)$ , Conjecture 5.1 implies Conjecture 1.10 except for the case  $r = 3$ . Moreover, the only extremal known examples reaching the upper bounds of Conjecture 5.1 are the same as for Conjecture 1.10 (see Figure 1.3(i)).

The case of  $r = 2$  has been proven by Chen *et al.* [33]. Song and Lai [109] proved that, if  $r \geq 8$ , then every planar graph verifies  $\chi_r(G) \leq 2r + 16$ . Similar to 2-distance coloring, the coefficient before  $r$  in this upper bound becomes 1 for graphs with a higher girth. Table 5.1 shows all latest results of the following form: *let  $r$  and  $r_0$  be integers such that  $r \geq r_0$ , every planar graph  $G$  of girth  $g(G) \geq g_0$  satisfies  $\chi_r(G) \leq r + c(g_0, r_0)$ , where  $c(g_0, r_0)$  is a constant depending only on  $g_0$  and  $r_0$ .*

$\chi_r(G)$ $g_0$	$r + 1$	$r + 2$	$r + 3$	$r + 4$	$r + 5$	$r + 6$	$r + 7$	...	$r + 10$
3			$r = 2$ [33]				$r = 3$ [94]		
4									
5					$r \geq 15$ [26] <sup>1</sup>				all $r$ [26]
6					$r \geq 3$ [91]				
7		$r = 2$ [76] <sup>2</sup>		$r = 3$ [75] <sup>2</sup>					
8	$r \geq 9$								
9	$r \geq 8$ [27] <sup>2</sup>		$r = 3$ [75] <sup>2</sup>						
10	$r \geq 6$ [27] <sup>2</sup>								
11									
12	$r \geq 5$ [27] <sup>2</sup>								
13									
14		$r = 3$ [34]							

Bảng 5.1: The latest results with a coefficient 1 before  $r$  in the upper bound of  $\chi_r$ .

The result from the “9” line and “ $r + 1$ ” column reads “for  $r \geq 8$ , every planar graph  $G$  of girth at least 9 satisfies  $\chi_r(G) \leq r + 1$ ”. Since an  $r$ -hued coloring is a 2-distance coloring when  $r \geq \Delta$ , some results for 2-distance colorings come from  $r$ -hued colorings. Similarly to 2-distance colorings, many of these results also come from  $r$ -hued list-colorings, or  $r$ -hued colorings of graphs with a bounded maximum average degree.

We are interested in the case  $\chi_r(G) = r + 1$  (as  $r + 1$  is a trivial lower bound for  $\chi_r(G)$  as soon as the graph contains a vertex of degree at least  $r$ ). In particular, we were looking for the smallest integer  $r$  such that a planar graph of girth at least 8 can be  $r$ -hued colored with  $r + 1$  colors, with the aim to find a sufficiently good lower bound to obtain a new result on 2-distance coloring.

Our result on  $r$ -hued coloring is the following.

**Theorem 5.2** ([88]). If  $G$  is a planar graph with  $g(G) \geq 8$ , then  $\chi_r(G) \leq r + 1$  for  $r \geq 9$ .

Hence for  $r = \Delta$ , we obtain the following theorem.

**Theorem 5.3** ([88]). If  $G$  is a planar graph with  $g(G) \geq 8$ , then  $\chi^2(G) \leq \Delta(G) + 1$  for  $\Delta(G) \geq 9$ .

## Proof of Theorem 5.2

Here, we employ more “traditional” discharging proof techniques while also focusing on faces to exploit the planarity of the graph.

Let us now consider  $G$  a counterexample to Theorem 5.2 with the fewest number of edges and vertices. The purpose of the proof is to prove that  $G$  cannot exist.

<sup>1</sup>Corollaries of results on  $r$ -hued list-colorings of planar graphs.

<sup>2</sup>Corollaries of results on  $r$ -hued list-colorings of graphs with a bounded maximum average degree.

**Structural properties of  $G$**

When we deal with vertices with degree less than  $r$ , the behavior of the  $r$ -hued coloring is similar to a 2-distance coloring, thus we obtain very similar structural results. As for vertices with degree larger than  $r$ , it is often easier to color the configuration as we have less constraints than 2-distance coloring.

This can be illustrated with some initial assumptions on  $G$ . Without loss of generality, we can assume that  $G$  is connected. Moreover,  $\delta(G) \geq 2$ . Otherwise, we can simply remove the unique edge incident to such vertex  $v$  and color the resulting graph with an  $r$ -hued coloring  $\phi$ , which is possible due to the minimality of  $|E(G)|$ . Then, we add the edge back and check the degree of  $v$ 's unique neighbor  $x$  in  $G$ . If  $d(x) \leq r$ , then we can choose a color for  $v$  different from  $x$ 's and all of its neighbors' to maintain the  $r$ -hued property of the coloring. Here, we also need to check the case where  $d(x) > r$ . In this case,  $x$  is already  $r$ -hued, so it suffices to choose a color for  $v$  different from  $\phi(x)$ .

In a similar fashion, the proofs of Lemmas 5.4 to 5.9 are very similar to that of Lemmas 2.12 to 2.18 and Lemma 2.21, and will thus be omitted (these proofs can be found in the corresponding article [88] in the Appendices).

**Lemma 5.4.** Let  $w$  be a vertex of  $G$  that is adjacent to  $k$  vertices  $u_i$  ( $k \leq d(w)$ ), each satisfying  $d^*(u_i) \leq r + i - 1$  for  $1 \leq i \leq k$ . Then we have  $d^*(w) \geq r + k + 1$ .

**Lemma 5.5.** Graph  $G$  has no  $4^+$ -threads.

**Lemma 5.6.** Both endvertices of a 3-thread have degree  $r$ .

**Lemma 5.7.** At least one of the endvertices of a 2-thread has degree  $r$  or both of them have degree  $r - 1$ .

**Lemma 5.8.** Graph  $G$  has no cycles consisting of 3-threads.

**Lemma 5.9.** Let  $v$  be a vertex such that  $3 \leq d(v) \leq \lfloor \frac{r+1}{2} \rfloor$ . Then  $v$  cannot be a  $(2, 1^+, 1^+, \dots, 1^+)$ -vertex.

**Lemma 5.10.** Graph  $G$  does not contain the configurations depicted by Figure 5.2.

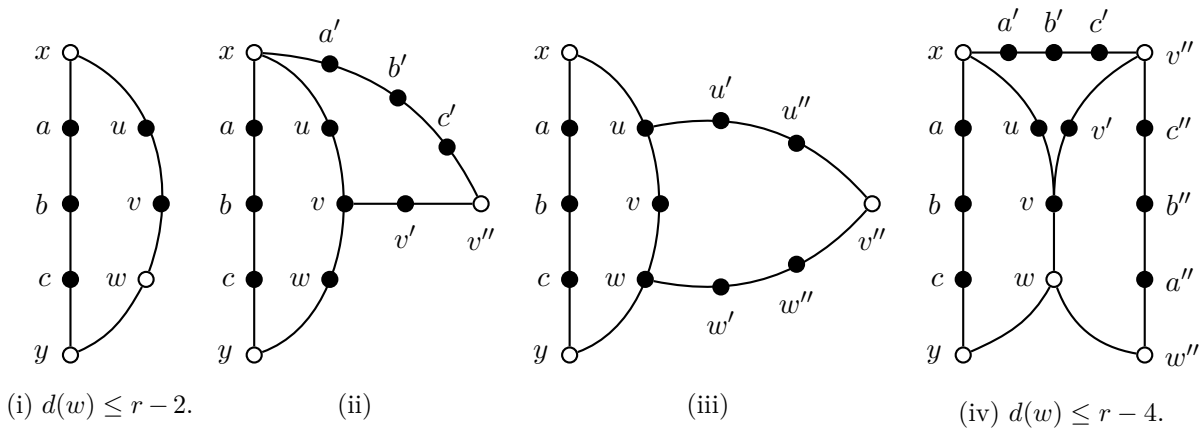

Hình 5.2: Configurations of Lemma 5.10.

*Chứng minh.* Recall that the endvertex of a 3-thread always have degree  $r$  by Lemma 5.6. Also, at least one endvertex of a 2-thread has degree  $r$  unless they both have degree  $r - 1$  by Lemma 5.7. Thus,  $x$ ,  $y$ , and  $v''$  always have degree  $r$  in what follows ( $r \geq 9$ ).

- (a) Consider the configuration depicted on Figure 5.2(i) where  $d(w) \leq r - 2$ .

By minimality of  $G$ , let  $\phi$  be an  $r$ -hued coloring of  $G' = G - \{a, b, u, v\}$ . Let us start coloring  $a$  and  $u$ . Both vertices have  $r - 2 + 1 = r - 1$  restrictions coming from  $x$ . Additionally,  $a$  (resp.  $u$ ) has one restriction from  $c$  (resp.  $w$ ). As  $\phi(c) \neq \phi(w)$  (since  $d(y) = r$ ), one can color  $a$  and  $u$  with two distinct colors. Finally,  $b$  and  $v$  can always be 2-distance colored since  $b$  only has four restrictions on its number of colors, and  $v$  always has at least one choice of color as  $d(w) \leq r - 2$ . The obtained coloring is  $r$ -hued. That contradiction completes the proof.

- (b) Consider the configuration depicted on Figure 5.2(ii).

By minimality of  $G$ , let  $\phi$  be an  $r$ -hued coloring of  $G' = G - \{a, b, c, u, v, w, a', b', c', v'\}$ . Observe first that, since  $d^*(b) < r + 1$ ,  $d^*(v) < r + 1$ ,  $d^*(b') < r + 1$ , vertices  $b, v, b'$  can be 2-distance colored at the end. Vertices  $a, u, a'$  have the same  $r - 2$  restrictions coming from  $x$ ; they must be colored with the last three available colors, say  $\alpha_1, \alpha_2, \alpha_3$ . Similarly  $c$  and  $w$  (resp.  $c'$  and  $v'$ ) have the same  $r - 1$  restrictions coming from  $y$  (resp.  $v''$ ); they must be colored with the last two available colors, say  $\beta_1$  and  $\beta_2$  (resp.  $\gamma_1$  and  $\gamma_2$ ). Now, if  $\beta_1$  does not occur in  $\{\alpha_1, \alpha_2, \alpha_3\}$ , then one can sequentially color  $c$  with  $\beta_1$ , then  $w, v', u, c', a'$ , and  $a$ . So by symmetry, we have  $\{\beta_1, \beta_2\} \subset \{\alpha_1, \alpha_2, \alpha_3\}$  and  $\{\gamma_1, \gamma_2\} \subset \{\alpha_1, \alpha_2, \alpha_3\}$ . It follows that  $\{\beta_1, \beta_2\}$  and  $\{\gamma_1, \gamma_2\}$  have at least one common element, say  $\beta_1 = \gamma_1$ . Hence we color the vertices as follows:  $c$  with  $\beta_1$ ,  $w$  with  $\beta_2$ ,  $v'$  with  $\gamma_1 = \beta_1$ ,  $c'$  with  $\gamma_2$  (which may be equal to  $\beta_2$ ),  $a'$  with  $\beta_1$ ,  $a$  with  $\beta_2$ , and  $u$  with the color of  $\{\alpha_1, \alpha_2, \alpha_3\} \setminus \{\beta_1, \beta_2\}$ . That leads to an  $r$ -hued coloring of  $G$ , a contradiction.

- (c) Consider the configuration depicted on Figure 5.2(iii).

By minimality of  $G$ , let  $\phi$  be an  $r$ -hued coloring of  $G' = G - \{a, b, c\}$ . Since  $d^*(b) < r + 1$ ,  $d^*(v) < r + 1$ ,  $d^*(u') < r + 1$ ,  $d^*(w') < r + 1$ ,  $b$  can be 2-distance colored and the vertices  $v, u', w'$  can be 2-distance recolored at the end if necessary. Vertex  $a$  (resp.  $c$ ) has  $r$  restrictions coming from  $x$  and  $u$  (resp.  $y$  and  $w$ ). If  $a$  and  $c$  can be colored differently, then we obtain an  $r$ -hued coloring of  $G$ . So, they must have the same available color left, say  $\alpha$ . Without loss of generality, say  $\phi(u) = \beta$  and  $\phi(w) = \gamma$ . Since  $\phi$  is  $r$ -hued,  $\alpha, \beta, \gamma$  are all distinct. Moreover at least one of  $u''$  and  $w''$  has a color distinct from  $\alpha$ ; by symmetry say  $\phi(u'') \neq \alpha$ . We now recolor  $u$  with  $\alpha$ , we color  $a$  with  $\beta$ ,  $c$  with  $\alpha$ , we 2-distance color  $b$  and as well  $u', v, w'$  if necessary. That leads to an  $r$ -hued coloring of  $G$ , a contradiction.

- (d) Consider the configuration depicted on Figure 5.2(iv) where  $d(w) \leq r - 4$ .

By minimality of  $G$ , let  $\phi$  be an  $r$ -hued coloring of  $G' = G - \{a', b', c'\}$ . Recall that  $d(w) \leq r - 4$ ; so  $d^*(v) < r + 1$ . The same holds for  $d^*(b)$  and  $d^*(b')$ , so vertices  $v, b, b'$  can be 2-distance recolored at the end. Vertex  $a'$  (resp.  $c'$ ) has  $r$  restrictions coming from  $x, a, u$  (resp.  $v'', v', c''$ ). If  $a'$  and  $c'$  can be colored differently, then we can obtain an  $r$ -hued coloring of  $G$ . So, they must have the same available color left, say  $\alpha$ . Let  $\beta$  be the color of  $u$  and  $\gamma$  the one of  $a$ . Since  $\phi$  is  $r$ -hued,  $\alpha, \beta, \gamma$  are all distinct. If  $\phi(c) \neq \alpha$ , then we recolor  $a$  with  $\alpha$ ,  $a'$  with  $\gamma$ , and  $c'$  with  $\alpha$ . It follows that  $\phi(c) = \alpha$ . Now observe that, as  $d(y) = d(v'') = r$ , we have  $\phi(w) \neq \alpha$  and  $\phi(v') \neq \alpha$  (as  $\alpha$  is the available color for  $c'$ ). So we recolor  $u$  with  $\alpha$ ; we color  $a'$  with  $\beta$  and  $c'$  with  $\alpha$ . It remains to 2-distance recolor  $v$  if necessary and to 2-distance color  $b'$ . That leads to an  $r$ -hued coloring of  $G$ , a contradiction.

□

**Lemma 5.11.** Given a  $(2, 1, 0)$ -vertex  $v$  having a 7-neighbor, the endvertex of the 1-thread (distinct from  $v$ ) is a  $8^+$ -vertex.

*Chứng minh.* Suppose  $G$  contains a  $(2, 1, 0)$ -vertex  $v$  having three neighbors  $a, b, c$  such that  $a$  belongs to a 2-thread,  $b$  belongs to a 1-thread  $vbd$ , and such that  $c$  has degree 7 and  $d$  has degree

at most 7. See Figure 5.3. Let  $\phi$  be an  $r$ -hued coloring of  $G' = G - \{a, b, v\}$ . Let us sequentially 2-distance color  $v, b$ , and  $a$ . The obtained coloring is  $r$ -hued, a contradiction.  $\square$

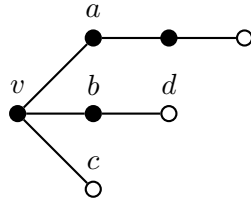

Hình 5.3: A  $(2, 1, 0)$ -vertex having a 7-neighbor.

### Discharging procedure

Before defining our discharging rules, we will define some special vertices.

**Definition 5.12** (Small, medium, and large 2-vertex). A 2-vertex  $v$  is said to be

- *large* if it is adjacent to two  $3^+$ -vertices,
- *medium* if it is adjacent to exactly one 2-vertex,
- *small* if it is adjacent to two 2-vertices.

**Definition 5.13** (Bridge vertex). A large 2-vertex is called a *bridge* if it has a 3-neighbor and a  $8^+$ -neighbor.

**Definition 5.14** (Sponsor). Consider the set of 3-threads in  $G$ . By Lemma 5.6, the endvertices of every 3-threads are  $r$ -vertices and by Lemma 5.8, the graph induced by the edges of all the 3-threads of  $G$  is a forest  $\mathcal{F}$ . For each tree of  $\mathcal{F}$ , we choose an arbitrary root. Each small 2-vertex  $v$  is assigned a unique *sponsor* which is the  $r$ -vertex corresponding to the grandson of  $v$ . See Figure 5.4.

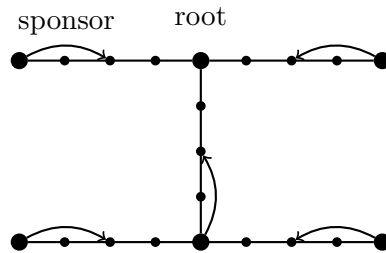

Hình 5.4: The sponsor assignment in a tree consisting of 3-threads.

**Definition 5.15** (Special and non-special vertices). A  $(3 \leftrightarrow 5)$ -vertex is said to be *special* if it has at least two  $r$ -neighbors and *non-special* otherwise.

We first assign to each vertex  $v$  the charge  $\mu(v) = 3d(v) - 8$  and to each face  $f$  the charge  $\mu(f) = d(f) - 8$ . Since  $\sum_{v \in V(G)} (3d(v) - 8) + \sum_{f \in F(G)} (d(f) - 8) = -16$  by Euler's formula, the total sum of the charges is negative. We then apply the following discharging rules.

**Vertices to vertices:****R0** (see Figure 5.5):

- (i) Every  $3^+$ -vertex gives 1 to its large 2-neighbors, and 2 to its medium 2-neighbors.
- (ii) Every sponsor gives 1 to its small 2-neighbors.
- (iii) Every  $8^+$ -vertex gives 1 to its adjacent bridges.

**R1** (see Figure 5.6):

- (i) Every  $8^+$ -vertex gives 2 to its 3-neighbors.
- (ii) Every  $(5 \leftrightarrow 7)$ -vertex  $v$  gives 1 to its 3-neighbors.
- (iii) Every bridge gives 1 to its 3-neighbor.

**R2** (see Figure 5.7):

- (i) Every  $8^+$ -vertex gives 2 to its 4-neighbors.
- (ii) Every  $(6 \leftrightarrow 7)$ -vertex gives 1 to its 4-neighbors.

**R3** (see Figure 5.8): Every  $8^+$ -vertex gives 2 to its 5-neighbors.**R4** (see Figure 5.9): Every special vertex gives 1 to its  $r$ -neighbors.**Vertices to faces:****R5** (see Figure 5.10): Each 8-face  $f = v_1v_2 \dots v_8$  with  $d(v_1) = d(v_7) = r$ ,  $3 \leq d(v_4) \leq 5$  and  $d(v_2) = d(v_3) = d(v_5) = d(v_6) = 2$ , receives charge  $\frac{1}{2}$  from  $v_1$  and  $v_7$ .**R6** (see Figure 5.13): Let  $f = xabcywvu$  be an 8-face where  $abcy$  is a 3-thread.

- (i) If  $xuvw$  is a 2-thread with  $d(w) \geq r - 1$ , then  $y$  gives  $\frac{1}{2}$  to  $f$ .
- (ii) If  $xuv$  is a 1-thread with  $d(v) \geq 4$ , then  $x$  gives  $\frac{1}{2}$  to  $f$ .
- (iii) If  $xuv$  is a 1-thread with  $d(v) = 3$  and  $d(w) \leq 5$ , then  $v$  gives  $\frac{1}{2}$  to  $f$ .
- (iv) If  $xuv$  is a 1-thread with  $d(v) = 3$  and  $d(w) \geq 6$ ,  $y$  gives  $\frac{1}{2}$  to  $f$ .
- (v) If  $d(u) \geq 6$  and  $d(w) \geq 3$ , then  $x$  gives  $\frac{1}{2}$  to  $f$ .
- (vi) If  $4 \leq d(u) \leq 5$  and  $d(w) \geq 3$ , then  $u$  gives  $\frac{1}{2}$  to  $f$ .
- (vii) If  $d(u) = 3$  and  $d(v) \geq 3$ , then  $u$  gives  $\frac{1}{2}$  to  $f$ .
- (viii) If  $u$  is a  $(1, 1, 0)$ -vertex, or a  $(1, 0, 0)$ -vertex, with  $d(v) = 2$ , and  $d(w) \geq 3$ , then  $u$  gives  $\frac{1}{2}$  to  $f$ .

**Faces to faces:****R7** (see Figure 5.11): Let  $f = xabcywvu$  be an 8-face where  $abcy$  is a 3-thread, and  $u$  and  $w$  are  $(2, 1, 0)$ -vertices (with the 1-thread in common). Let  $u'$ ,  $u''$ , and  $u'''$  (resp.  $w'$ ,  $w''$ , and  $w'''$ ) be, respectively, the 1-distance, 2-distance and 3-distance neighbor of  $u$  (resp.  $w$ ) along its incident 2-thread. We also suppose that  $u''' \neq w'''$ . Let  $f'$  be the  $9^+$ -face incident to  $u'''u''u'vwv'w''w'''$ . Face  $f'$  gives  $\frac{1}{2}$  to  $f$ .**Faces to vertices:****R8** (see Figure 5.12): Each face  $f$  gives  $\frac{1}{2}$  to each of its incident small 2-vertices<sup>3</sup>.**R9** (see Figure 5.10): Each  $8^+$ -face  $f$  incident to a path  $v_1v_2 \dots v_7$  as described in **R5** gives 1 to  $v_4$ .

---

<sup>3</sup> $f$  gives  $\frac{1}{2}$  twice to a small 2-vertex if that vertex is only incident to  $f$ .

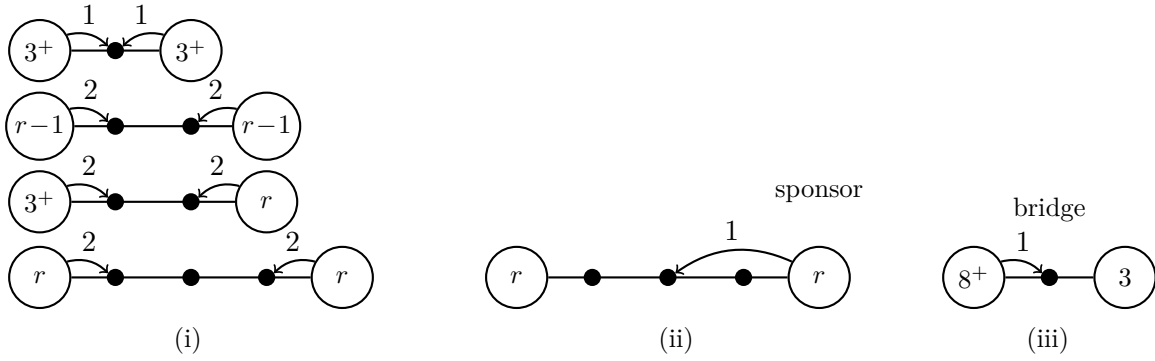

Hình 5.5: **R0**.

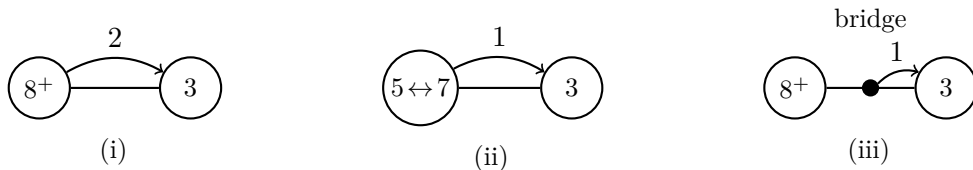

Hình 5.6: **R1**.

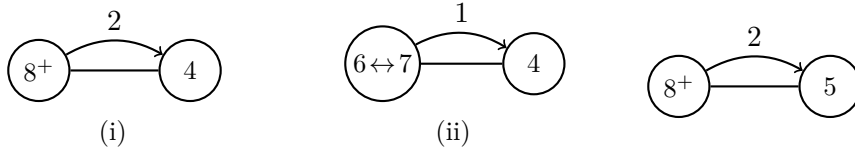

Hình 5.7: **R2**.

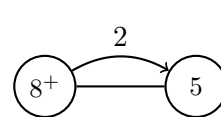

Hình 5.8: **R3**.

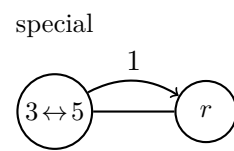

Hình 5.9: **R4**.

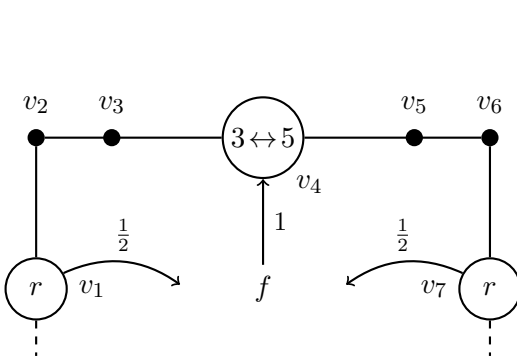

Hình 5.10: **R5** and **R9**.

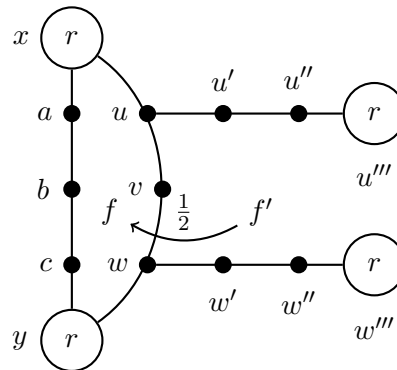

Hình 5.11: **R7**.

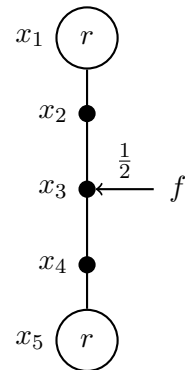

Hình 5.12: **R8**.

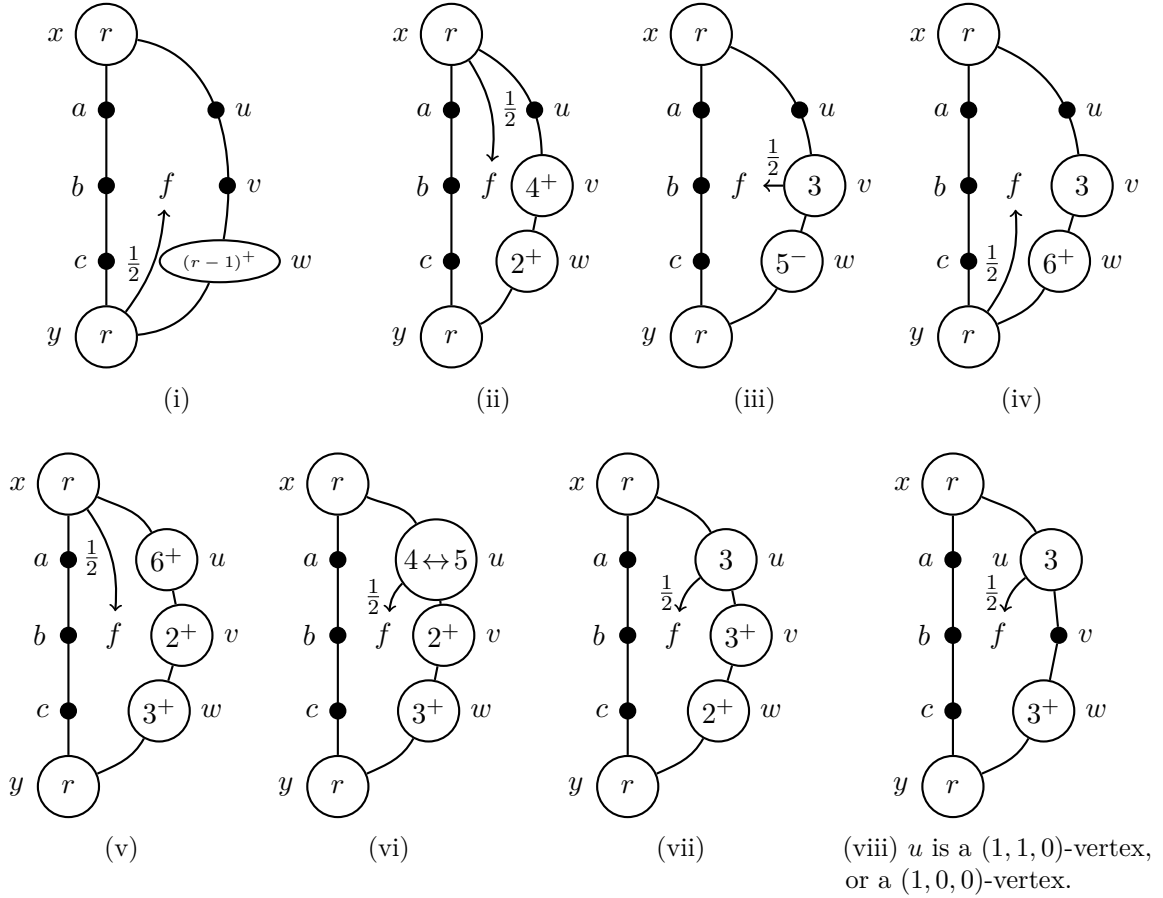

Hình 5.13: **R6**.

### Verifying that charges on vertices and faces are non-negative

Let  $\mu^*$  be the assigned charges after the discharging procedure. In what follows, we prove that:

$$\forall x \in V(G) \cup F(G), \mu^*(x) \geq 0$$

#### Faces

Let  $f$  be a face of  $G$ . Recall that  $\mu(f) = d(f) - 8$ . We consider two cases according to the length of  $f$ :

**Case 1:**  $d(f) \geq 9$ .

Note that  $f$  may give  $\frac{1}{2}$  (resp.  $\frac{1}{2}, 1$ ) by **R7** (resp. **R8, R9**). By **R9** (resp. **R8, R7**), face  $f$  may give 1 (resp.  $\frac{1}{2}, \frac{1}{2}$ ) at most  $\frac{d(f)}{6}$  (resp.  $\frac{d(f)}{4}, \frac{d(f)}{8}$ ) times. Observe that in Figures 5.10 to 5.12 except the  $r$ -vertices ( $u'', w'', x_1, x_5, v_1, v_7$ ), all other vertices are pairwise distinct. Therefore, assuming that **R9** (resp. **R8, R7**) is applied  $i$  (resp.  $j, k$ ) times, we must have  $d(f) \geq 6i + 4j + 8k$ .

Observe that:  $\mu^*(f) \geq d(f) - 8 - i - \frac{j}{2} - \frac{k}{2} \geq 6i + 4j + 8k - 8 - i - \frac{j}{2} - \frac{k}{2} \geq 5i + \frac{7}{2}j + \frac{15}{2}k - 8 \geq 0$  when  $i \geq 2$  or  $k \geq 2$  or  $j \geq 3$  or  $(j \geq 1$  and  $i = 1)$  or  $(j \geq 1$  and  $k = 1)$  or  $(i = 1$  and  $k = 1)$ . Now observe that for the remaining cases:  $\mu^*(f) \geq d(f) - 8 - i - \frac{j}{2} - \frac{k}{2} \geq 1 - i - \frac{j}{2} - \frac{k}{2} \geq 0$  when  $(i, j, k) = (1, 0, 0)$  or  $(i, j, k) = (0, 0, 1)$  or  $(i, j, k) = (0, 2^-, 0)$ . It follows that  $\mu^*(f) \geq 0$ .

**Case 2:**  $d(f) = 8$ .

Suppose  $f$  is not incident to a 3-thread. It follows that  $f$  is involved only in **R5** and **R9**. Observe that



if **R9** applies, then **R5** applies. In all cases, we have either  $\mu^*(f) \geq d(f) - 8 + 2 \cdot \frac{1}{2} - 1 = 8 - 8 + 1 - 1 = 0$  or  $\mu^*(f) \geq \mu(f) \geq 0$ .

Suppose that  $f$  is incident to a 3-thread. By Lemma 5.8,  $f$  has only one such thread on its boundaries. Face  $f$  gives once  $\frac{1}{2}$  by **R8** (and **R9** cannot be applied). We show now that  $f$  receives  $\frac{1}{2}$  by **R6** or **R7**. Let  $f = xabcywu$  where  $xabcy$  is a 3-thread.

- If  $f$  is also incident to a 2-thread of the form  $xuvw$ , then  $f$  gets  $\frac{1}{2}$  by **R6**(i) (see Figure 5.13(i)). Note that the case where  $d(w) \leq r - 2$  does not occur by Lemma 5.10(i).

$$\mu^*(f) \geq d(f) - 8 - \frac{1}{2} + \frac{1}{2} = 8 - 8 - \frac{1}{2} + \frac{1}{2} = 0.$$

- If  $f$  is incident to a 1-thread of the form  $xuv$ , then  $f$  gets  $\frac{1}{2}$  by **R6**(ii), (iii), or (iv) (see Figure 5.13(ii), (iii), (iv))).

$$\mu^*(f) \geq 0 - \frac{1}{2} + \frac{1}{2} = 0.$$

- If  $f$  is incident to a 1-thread of the form  $uvw$  and  $d(u) > 3$ , then  $f$  gets  $\frac{1}{2}$  from **R6**(v) or (vi) (see Figure 5.13(v), (vi)). If  $d(u) = 3$ , then  $u$  is either a  $(1, 1, 0)$ -vertex, or a  $(1, 0, 0)$ -vertex, or a  $(2, 1, 0)$ -vertex. By symmetry, the same reasoning holds for  $w$ . If one of them is a  $(1, 1, 0)$ -vertex, or a  $(1, 0, 0)$ -vertex, then  $f$  gets  $\frac{1}{2}$  by **R6**(viii) (see Figure 5.13(viii)). If both of them are  $(2, 1, 0)$ -vertices, then we are in Configuration **R7** (see Figure 5.11) with  $u''' \neq w'''$  by Lemma 5.10(iii). In that case,  $f$  also receives  $\frac{1}{2}$ . So, we have in all cases:

$$\mu^*(f) \geq 0 - \frac{1}{2} + \frac{1}{2} = 0.$$

- In the remaining case,  $f$  receives  $\frac{1}{2}$  by **R6**(v), (vi) or (vii) (see Figure 5.13(v), (vi), (vii)).

$$\mu^*(f) \geq 0 - \frac{1}{2} + \frac{1}{2} = 0.$$

## Vertices

**Observation 5.16.** Consider a special  $(3 \leftrightarrow 5)$ -vertex  $u$  adjacent to an  $r$ -vertex  $v$ . It follows that **R4** applies, so  $u$  gives 1 to  $v$ . In return, if  $d(u) = 3$  (resp.  $d(u) = 4$ ,  $d(u) = 5$ ), then  $v$  gives 2 to  $u$  by **R1**(i) (resp. **R2**(i), **R3**). Additionally,  $u$  may give  $\frac{1}{2}$  (at most twice) along  $uv$  to incident faces by **R6**(vi), (vii) or (viii) (see Figure 5.14). To sum up, when **R4** applies,  $u$  does not lose charge along  $uv$ , as in the worst case  $2 - 1 - 2 \cdot \frac{1}{2} = 0$ . Moreover, when **R6** does not apply,  $u$  gains  $2 - 1 = 1$ .

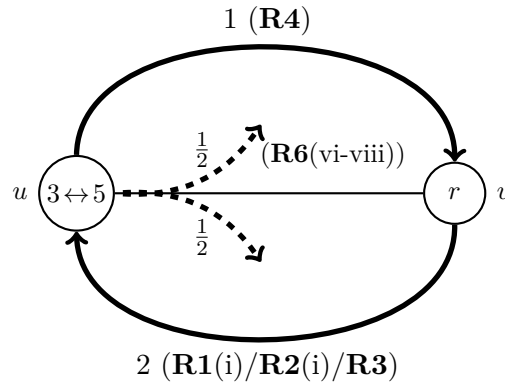

Hình 5.14: The charge distribution when **R4** applies. Dashed arrows indicate the possible application of **R6**.

**Case 1:**  $d(v) \geq 8$ .

Suppose first that  $d(v) \neq r$ . Observe that  $v$  is involved in **R0**(i) and (iii), **R1**(i), **R2**(i), **R3** and  $v$  gives at most 2 to each adjacent vertex by **R0**(i), **R1**(i), **R2**(i), **R3** or a combination of **R0**(i) and (iii) (in the case of a bridge). Hence,

$$\mu^*(v) \geq 3d(v) - 8 - 2d(v) = d(v) - 8 \geq 0.$$

Suppose now that  $d(v) = r$ . Additionally,  $v$  also gives charges to faces by **R5** and **R6** and to sponsored small 2-vertices by **R0**(ii). Using the same idea as before, we show that  $v$  gives at most 2 along each incident edge.

When **R5** is applied to  $v$ , w.l.o.g.  $v_1 = v$  in Figure 5.10, one sends  $\frac{1}{2}$  to  $f$  via the edge  $v_1v_8$ . The edge  $v_1v_8$  belongs to two faces, hence  $v_1v_8$  may be involved twice by **R5**. If  $v_8$  has degree at least 6, then no additional charges transit via  $v_1v_8$ . If  $v_8$  is a  $(3 \leftrightarrow 5)$ -vertex, then  $v_1$  gives 2 to  $v_8$  by **R1**(i), **R2**(i), and **R3**, but it receives 1 by **R4** since  $v_8$  would be special as  $v_1, v_7$  are  $r$ -vertices. If  $v_8$  has degree 2, then only 1 may transit by **R0**(i). In all cases, at most 2 transits from  $v_1$  along  $v_1v_8$ .

Consider now that **R6** is applied to  $v$ . As previously, we show that the charge  $\frac{1}{2}$  is given to  $f$  via a particular edge on which at most 2 transits. Rule **R6** is applied to  $v$  in the cases **R6**(i), **R6**(ii), **R6**(iv), and **R6**(v). Observe that no charges are given to  $6^+$ -vertices. Hence charge  $\frac{1}{2}$  transits (at most twice) along edge  $yw$  in **R6**(i) and **R6**(iv), along edge  $xu$  in **R6**(v). In case **R6**(ii), charge  $\frac{1}{2}$  transits (at most twice) along edge  $xu$  and  $x = v$  gives 1 to  $u$  by **R0**(i). Again at most 2 transits along each incident edge.

Finally, vertex  $v$  can sponsor at most one small 2-vertex by the definition of the sponsor relation and **R0**(ii). It follows that:

$$\begin{aligned} \mu^*(v) &\geq 3d(v) - 8 - 2d(v) - 1 \\ &\geq d(v) - 9 = r - 9 \geq 0 \end{aligned}$$

**Case 2:**  $d(v) = 7$ .

Observe that  $v$  may send 1 by **R1**(ii), **R2**(ii), and **R0**(i) in the case of the 1-thread, and may send 2 by **R0**(i) in the case of the 2-thread. As  $\mu(v) = 13$ ,  $\mu^*(v) \geq 0$  except in the case where  $v$  is incident to seven 2-threads, but in that case  $d^*(v) = 14$ , contradicting Lemma 5.4 (that implies  $d^*(v) \geq 17$ ).

**Case 3:**  $d(v) = 6$ .

Vertex  $v$  may give 1 (resp. 2, 1, 1) by **R0**(i) in the case of the 1-thread (resp. **R0**(i) in the case of the 2-thread, **R1**(ii), **R2**(ii)). As  $\mu(v) = 10$ ,  $\mu^*(v) \geq 0$  except in the case where  $v$  gives 2 to each of five of its neighbors and gives at least 1 to its last neighbor, but in that case  $d^*(v) \leq 14$ , contradicting Lemma 5.4 (that implies  $d^*(v) \geq 15$ ).

**Case 4:**  $d(v) = 5$ .

Vertex  $v$  may give 1 (resp. 2, 1, 1,  $\frac{1}{2}$ ) by **R0**(i) in the case of the 1-thread (resp. **R0**(i) in the case of the 2-thread, **R1**(ii), **R4** when it is a special vertex, and **R6**(vi)) and may receive 2 (resp. 1) by **R3**(i) (resp. **R9**). Recall  $\mu(v) = 7$ .

Suppose that **R6**(vi) is applied to  $v$  ( $v$  plays the role of  $u$  in Figure 5.13(vi)). Let us use the notations of Figure 5.13(vi). Hence  $u$  gives  $\frac{1}{2}$  to  $f$  (let say via the edge  $ux$ ). It may give 1 to  $x$  by **R4** (if  $u$  is special), and receives 2 from  $x$  by **R3**. Moreover **R6**(vi) may be applied to the two faces incident to  $ux$ . When we sum the charges transiting along  $ux$ ,  $u$  may give at most  $2 \cdot \frac{1}{2} - 2 + 1 = 0$ . Hence in the following we consider that, if **R6**(vi) is applied to  $u$ , no charges are transferred along  $ux$ .

By Lemma 5.9,  $v$  is not a  $(2, 1^+, 1^+, 1^+, 1^+)$ -vertex. Hence  $v$  is incident to at most four 2-threads. If  $v$  is incident to four 2-threads, then  $v$  receives 1 from three incident faces by **R9** and may give at most 2, 2, 2, 2, 1 along incident edges ; so  $\mu^*(v) \geq 7 + 3 - 4 \cdot 2 - 1 = 1$ . If  $v$  is incident to

exactly three 2-threads, then  $v$  receives at least 1 by **R9** and may give at most 2, 2, 2, 1, 1 along incident edges ; so  $\mu^*(v) \geq 7 + 1 - 3 \cdot 2 - 2 \cdot 1 = 0$ . If  $v$  is incident to at most two 2-threads, then  $\mu^*(v) \geq 7 - 2 \cdot 2 - 3 \cdot 1 = 0$ .

**Case 5:**  $d(v) = 4$ .

Vertex  $v$  may give 1 (resp. 2, 1,  $\frac{1}{2}$ ) by **R0(i)** in the case of the 1-thread (resp. **R0(i)** in the case of the 2-thread, **R4**, **R6(vi)**) and may receive 2 (resp. 1, 1) by **R2(i)** (resp. **R2(ii)**, **R9**). Recall  $\mu(v) = 4$ . Similar to 5-vertices, if **R6(vi)** is applied to  $v$ , then no charges are transferred along the edge linking  $v$  and the  $r$ -vertex. By Lemma 5.9,  $v$  is not a  $(2, 1^+, 1^+, 1^+)$ -vertex. Hence,  $v$  is incident to at most three 2-threads.

If  $v$  is incident to three 2-threads, then  $v$  is not special,  $v$  receives 1 from two incident faces by **R9** and gives 2, 2, 2, 0 along incident edges ; so  $\mu^*(v) = 4 + 2 \cdot 1 - 3 \cdot 2 = 0$ .

Suppose now that  $v$  is incident to two 2-threads. If  $v$  is not incident to a 1-thread, then we are done as  $\mu^*(v) = 4 - 2 \cdot 2 = 0$  whether  $v$  is special or not due to Observation 5.16. So consider that  $v$  is incident to exactly one 1-thread by Lemma 5.9 and so is not special. The  $3^+$ -neighbor of  $v$  has degree at least 6 (otherwise it contradicts Lemma 5.4,  $d^*(v) \leq 11$  while we must have  $d^*(v) \geq 12$ ), then it gives at least 1 to  $v$  by **R2** and so  $\mu^*(v) \geq 4 + 1 - 2 \cdot 2 - 1 = 0$ .

Finally assume that  $v$  is incident to at most one 2-thread. If  $v$  gives at most one along each incident edge, then we are done (as  $\mu^*(v) \geq 4 - 4 \cdot 1 \geq 0$ ). So assume that  $v$  gives 2 to one of its neighbors. In that case, it means that **R0(i)** applied and  $v$  is thus incident to exactly one 2-thread. Since  $v$  is not a  $(2, 1^+, 1^+, 1^+)$ -vertex, it may be incident to at most two 1-threads. If  $v$  is incident to a 2-thread and two other 1-threads, then  $v$  is not special. Hence we have  $\mu^*(v) \geq 4 - 2 - 1 - 1 \geq 0$ .

**Case 6:**  $d(v) = 3$ .

Vertex  $v$  may give 1 (resp. 2,  $\frac{1}{2}$ , 1) by **R0(i)** in the case of the 1-thread (resp. **R0(i)** in the case of the 2-thread, **R6**, **R4**) and may receive 2 (resp. 1, 1, 1) by **R1(i)** (resp. **R1(ii)**, **R1(iii)**, **R9**). Recall  $\mu(v) = 1$ . By Lemma 5.9,  $v$  is not a  $(2, 1^+, 1^+)$ -vertex. Let us examine all possible configurations for  $v$ .

- Suppose that  $v$  is a  $(2, 2, 0)$ -vertex. Let  $v_1, v_2$ , and  $u$  be the two 2-neighbors and  $3^+$ -neighbor of  $v$  respectively. Since  $v$  is not special, **R4** does not apply. Vertex  $v$  does not fall into any configuration of **R6**, so **R6** does not apply. Vertex  $v$  gives 2 to each of its 2-neighbors by **R0(i)**. By Lemma 5.7, the other endvertices of the two 2-threads are  $r$ -vertices; so  $v$  falls into the configuration in **R9** and receives 1 from an incident face. Moreover,  $v_1$  and  $v_2$  satisfy  $d^*(v_i) = 5 \leq r$  ( $i = 1, 2$ ). By Lemma 5.4,  $d^*(v) \geq 12$  and  $d^*(v) = d(u) + 4$ , so  $d(u) \geq 8$ . By **R1(i)**,  $v$  receives 2 from  $u$ . In total, we have

$$\mu^*(v) \geq 1 - 2 \cdot 2 + 1 + 2 = 0.$$

- Suppose that  $v$  is a  $(2, 1, 0)$ -vertex. Let  $v_1, v_2$ , and  $u$  be the two 2-neighbors (where  $v_1$  belongs to the 2-thread and  $v_2$  belongs to the 1-thread) and  $3^+$ -neighbor of  $v$  respectively. As previously,  $v$  is not special. Vertex  $v_1$  has  $d^*(v_1) = 5 \leq r$ . By Lemma 5.4,  $d^*(v) \geq 11$ , and  $d^*(v) = d(u) + 4$ , so  $d(u) \geq 7$ . It follows that **R6** does not apply (in particular **R6(iii)**).

If  $d(u) \geq 8$ , then  $v$  receives 2 from  $u$  by **R1(i)**. Hence, by **R0(i)** and **R1(i)**, we have:

$$\mu^*(v) \geq 1 - 2 - 1 + 2 = 0.$$

If  $d(u) = 7$ , then  $v$  receives 1 from  $u$  by **R1(ii)**. Moreover, the neighbor of  $v_2$  (different from  $v$ ) has degree at least 8 by Lemma 5.11. Hence  $v$  receives 1 from  $v_2$  by **R1(iii)**. It follows that:

$$\mu^*(v) \geq 1 - 2 - 1 + 1 + 1 = 0.$$

- Suppose that  $v$  is a  $(2, 0, 0)$ -vertex. Let  $x_1, x_2$  be the 0-thread neighbors of  $v$  and  $v_1$  be the 2-thread neighbor of  $v$ .

Suppose first that  $v$  is not concerned by **R6(vii)** (i.e.  $v$  only gives charge to vertices). Vertex  $v_1$  satisfies  $d^*(v_1) = 5 \leq r$ . By Lemma 5.4,  $d^*(v) \geq r + 2$ . Since  $d^*(v) = d(x_1) + d(x_2) + 2$ , we have  $d(x_1) + d(x_2) \geq r \geq 9$ . W.l.o.g.  $x_1$  has degree at least 5. Note that, if  $v$  is non-special, then **R4** does not apply and  $v$  receives at least 1 from  $x_1$  by **R1(i)** or **R1(ii)**; if  $v$  is special, then  $d(x_1) = d(x_2) = r$ ,  $v$  gives 1 to  $x_1$  and  $x_2$  by **R4** and receives 2 from  $x_1$  and  $x_2$  by **R1(i)**. In both case, we can consider that  $v$  receives at least 1 from  $x_1$ . So

$$\mu^*(v) \geq 1 - 2 + 1 = 0.$$

Suppose now that **R6(vii)** is applied to  $v$ . Observe that **R6(vii)** is applied once. If  $v$  is non-special, then  $v$  receives 2 from its  $r$ -neighbor by **R1(i)**; if it is special, by the same arguments as in the previous paragraph, we can consider that  $v$  receives 1 from both  $x_1$  and  $x_2$  (by **R1(i)** and **R4**). So

$$\mu^*(v) \geq 1 - 2 - \frac{1}{2} + 2 > 0.$$

- Suppose that  $v$  is a  $(1, 1, 1)$ -vertex. Note that only **R0(i)**, **R1(iii)**, and **R6(iii)** may concern  $v$ . Vertex  $v$  gives 1 to each 2-neighbor by **R0(i)** and  $\frac{1}{2}$  to at most one incident face by **R6(iii)** and Lemma 5.10(ii). Let  $vxw$  be a 1-thread incident to  $v$ . We have  $d^*(v) = 6 \leq r$ . It follows that  $d^*(x) \geq 11$  by Lemma 5.4 and as  $d^*(x) = d(w) + 3$ , we have  $d(w) \geq 8$ , meaning that **R1(iii)** applies. Thus,

$$\mu^*(v) \geq 1 - 3 \cdot 1 - \frac{1}{2} + 3 \cdot 1 > 0.$$

- Suppose that  $v$  is a  $(1, 1, 0)$ -vertex. Let  $vv_1w_1$  and  $vv_2w_2$  be the two 1-threads incident to  $v$  and let  $u$  be the  $3^+$ -neighbor of  $v$ . Note that  $v$  is not special, and it may be concerned by **R0(i)**, **R1**, **R6(iii)**, and **R6(viii)**.

Suppose first that  $v$  is not concerned by **R6** (i.e.  $v$  only gives charge to vertices). By **R0(i)**,  $v$  gives 1 to each of its 2-neighbors.

If  $d(u) \geq 5$ , then we have by **R1(i)** and **R1(ii)**:

$$\mu^*(v) \geq 1 - 2 \cdot 1 + 1 = 0.$$

If  $d(u) \leq 4$ , then  $d^*(v) = 8 \leq r$ . By Lemma 5.4,  $d^*(v_1) \geq 11$ . As  $d^*(v_1) = d(w_1) + 3$ , we have  $d(w_1) \geq 8$  meaning that  $v$  receives 1 from  $v_1$  by **R1(iii)** (and from  $v_2$  by symmetry). Hence,

$$\mu^*(v) \geq 1 - 2 \cdot 1 + 2 \cdot 1 > 0.$$

Suppose that **R6(iii)** or **R6(viii)** is applied to  $v$ .

Assume we are in configuration **R6(viii)**. Vertex  $v$  gives 1 to each of its 2-neighbors and  $\frac{1}{2}$  to at most three incident faces (by a combination of **R6(iii)** and **R6(viii)**), and receives 2 from  $u$  by **R1(i)**. If it gives charge to three faces, then  $w_1$  and  $w_2$  are also endvertices of a 3-thread, meaning that they are of degree  $r \geq 8$ . By **R1(iii)**,  $v$  receives 1 from each bridge  $v_1$  and  $v_2$ . Thus,

$$\mu^*(v) \geq 1 - 2 \cdot 1 - 3 \cdot \frac{1}{2} + 2 + 2 \cdot 1 > 0.$$

Now, if  $v$  only gives charge to at most two faces, then we have:

$$\mu^*(v) \geq 1 - 2 \cdot 1 - 2 \cdot \frac{1}{2} + 2 = 0.$$

Assume we are in configuration **R6**(iii) (only, otherwise we are in the previous case). Let us reuse the notation of Figure 5.13. Observe that either  $w$  has degree 2 and  $u$  and  $w$  are two bridges (since  $x$  and  $y$  are  $r$ -vertices), or  $w$  is a  $(3 \leftrightarrow 5)$ -vertex and the endvertices of the 1-threads incident to  $v$  (different from  $v$ ) are  $8^+$ -vertices by Lemma 5.4 implying that the 2-neighbors of  $v$  are bridges. Hence if **R6**(iii) is applied at most twice, we have by **R0**(i) and **R1**(iii):

$$\mu^*(v) \geq 1 - 2 \cdot 1 - 2 \cdot \frac{1}{2} + 2 \cdot 1 = 0.$$

Now, if **R6**(iii) is applied three times, then we obtain the configuration depicted by Figure 5.2(iv) which is forbidden by Lemma 5.10.

- Suppose that  $v$  is a  $(1, 0, 0)$ -vertex. Let  $u$ ,  $v_1$ , and  $v_2$  be its 2-neighbor and the two  $3^+$ -neighbors of  $v$ , respectively. First note that each time **R4** applies, by Observation 5.16, in the worst case, the total number of charges transferred via  $vv_1$  and  $vv_2$  is 0. So,

$$\mu^*(v) \geq 1 - 1 = 0$$

Suppose now that **R6**(iii), (vii) or (viii) is applied to  $v$  (which is not special).

If **R6**(vii) or **R6**(viii) is applied to  $v$ , then (at least) one of the  $3^+$ -neighbors of  $v$  is an  $r$ -vertex. So  $v$  gains 2 by **R1**(i). It follows that

$$\mu^*(v) \geq 1 - 1 - 3 \cdot \frac{1}{2} + 2 > 0.$$

Suppose now only **R6**(iii) is applied to  $v$ . Observe that **R6**(iii) may be applied at most twice. Vertex  $v$  receives 1 from the bridge by **R1**(iii). Hence,

$$\mu^*(v) \geq 1 - 1 - 2 \cdot \frac{1}{2} + 1 = 0.$$

- Suppose that  $v$  is a  $(0, 0, 0)$ -vertex. If **R4** is applied (i.e.  $v$  is special), then  $v$  does not need any charge by Observation 5.16. Suppose that  $v$  is not special. Vertex  $v$  may give charge to faces only by **R6**(vii) and in that case it receives 2 from its  $r$ -neighbor by **R1**(i). It follows that:

$$\mu^*(v) \geq 1 - 3 \cdot \frac{1}{2} + 2 > 0.$$

**Case 7:**  $d(v) = 2$ .

We have  $\mu(v) = -2$ . Vertex  $v$  receives 2 by **R0**(i) unless  $v$  is a small 2-vertex. When  $v$  is small, it receives 1 from its sponsor by **R0**(ii) and twice  $\frac{1}{2}$  from incident faces by **R8**. Now if  $v$  is a bridge, then it also gives 1 to a 3-vertex by **R1**(iii), but it also receives 1 from **R0**(iii). In all cases,  $\mu^*(v) = 0$ .

To sum up, we have proven that we started out with a negative total number of charge, and after the discharging procedure that preserves this sum, we end up with a non-negative one, a contradiction. That completes the proof of Theorem 5.2.

## 5.2 Injective and exact square coloring

---

A 2-distance coloring can also be seen as a proper coloring of such that every pair of vertices with a common neighbor receive distinct colors. If we remove the proper constraint on the coloring, then we get what is called an *injective coloring*. The *injective chromatic number*, denoted by  $\chi^i(G)$ , is the smallest integer  $k$  such that there exists an injective coloring of  $G$  with  $k$  colors. We can also extend these notions to list coloring.

The injective coloring was first introduced in 2002 by Hahn *et al.* [64]. The authors proved that for every graph  $G$ ,  $\Delta \leq \chi^i(G) \leq \Delta^2 - \Delta + 1$ . They also characterized the regular graphs which achieve the lower bound, and the graphs which attain the upper bound. In 2005, Doyon *et al.* [49] presented the first results on injective colorings of planar graphs and later Chen *et al.* [32] posed the following conjecture.

**Conjecture 5.17** (Chen *et al.* [32]). Let  $G$  be a planar graph with maximum degree  $\Delta$ . Then,

$$\chi^i(G) \leq \left\lceil \frac{3}{2}\Delta \right\rceil.$$

As injective coloring is less restrictive, one might believe that it will require less colors than 2-distance coloring. However, in 2015, Lužar and Škrekovski [95] refuted this false intuition and Conjecture 5.17 was proven to be incorrect. In their paper, they presented an infinite family of planar graphs with small maximum degree (between 4 and 7), or of even maximum degree, for which Conjecture 5.17 is false. For  $\Delta \in \{4, 5, 6, 7\}$  they proved that there exist planar graphs which require  $\Delta + 5$  colors and for  $\Delta \geq 8$  they proved that there exist planar graphs which require  $\lfloor \frac{3}{2}\Delta \rfloor + 1$  colors, which is one more color than the conjectured bound. Finally, the authors proposed a conjecture which closely resembles Wegner's conjecture with the only difference being the subcubic case.

**Conjecture 5.18** (Lužar, Škrekovski [95]). Let  $G$  be a planar graph with maximum degree  $\Delta$ . Then,

$$\chi^i(G) \leq \begin{cases} 5, & \text{if } \Delta \leq 3, \\ \Delta + 5, & \text{if } 4 \leq \Delta \leq 7, \\ \lfloor \frac{3}{2}\Delta \rfloor + 1, & \text{if } \Delta \geq 8. \end{cases}$$

Note that since injective coloring is a relaxation of the 2-distance coloring, proving Wegner's conjecture would prove Conjecture 5.18 (except in the case of subcubic graphs). Brimkov *et al.* [21] proved that 5 colors suffice for subcubic planar graphs with girth at least 6, but in general the case when  $\Delta = 3$  is still open. If true, then the conjectured upper bound for subcubic graphs is also tight (see [95]). For the sake of completeness we present a table summarizing the latest known results regarding the injective chromatic number of planar graphs for different girth values like what we did for 2-distance coloring.

Table 5.2 is read as follows. For example, the result from line “7” and column “ $\Delta$ ” reads: “every planar graph  $G$  of girth at least 7 and of  $\Delta$  at least 16 satisfies  $\chi^i(G) \leq \Delta + 1$ ”. The highlighted results are part of our contribution.

The negative results are the following:

- Girth 3 to 6 in column “ $\Delta$ ” correspond to Figure 5.15.
- Girth 10 in column “ $\Delta$ ” corresponds to the existence of a subcubic graph with girth 10 and  $\chi^i \geq 4$  [96].
- Similar constructions for girth 3 in columns “ $\Delta + 1$ ” to “ $\Delta + 4$ ” are presented in [32] and [95].
- Girth 3 and columns “ $\Delta + 5$ ” to “ $\Delta + 7$ ” correspond to the existence of a planar graph with girth 3 and  $\chi^i \geq \lfloor \frac{3}{2}\Delta \rfloor + 1$  for all  $\Delta \geq 8$  [95].
- Girth 4 and columns “ $\Delta + 1$ ” to “ $\Delta + 7$ ” correspond to the existence of a planar graph with girth 4 and  $\chi^i \geq \lceil \frac{3}{2}\Delta \rceil$  for all  $\Delta \geq 3$  [96].

$\chi^i$ $g_0$	$\Delta$	$\Delta + 1$	$\Delta + 2$	$\Delta + 3$	$\Delta + 4$	$\Delta + 5$	$\Delta + 6$	$\Delta + 7$
3	/	/	$\Delta \geq 4$ [95]	$\Delta \geq 4$ [95] $\Delta = 3$ [32]	$\Delta \geq 4$ [95]	$\Delta \geq 10$ [95]	$\Delta \geq 12$ [95]	$\Delta \geq 14$ [95] $\Delta = 4$
4	/	$\Delta \geq 4$ [96]	$\Delta \geq 6$ [96]	$\Delta \geq 8$ [96] $\Delta = 3$ [32]	$\Delta \geq 10$ [96]	$\Delta \geq 12$ [96] $\Delta = 4$	$\Delta \geq 14$ [96]	$\Delta \geq 16$ [96]
5	/			$\Delta = 3$ [32] $\Delta \geq 35$ [45]	$\Delta \geq 11$ [23]	$\Delta \geq 11$ [23]	$\Delta \geq 3$ [45]	
6	/	$\Delta \geq 17$ [44]	$\Delta = 3$ [21] $\Delta \geq 8$ [30]	$\Delta \geq 3$ [44]				
7	$\Delta \geq 16$ [14]	$\Delta \geq 7$ [29]	$\Delta = 3$ [96] $\Delta \geq 4$ [38]					
8	$\Delta \geq 10$ [14]	$\Delta \geq 5$ [30]						
9	$\Delta \geq 9$ [31]	$\Delta \geq 4$ [41]						
10	$\Delta \geq 6$ [14] $\Delta = 3$ [96]	$\Delta \geq 3$ [96]						
11								
12	$\Delta \geq 5$ [14]							
13	$\Delta \geq 4$ [41]							
19	$\Delta \geq 3$ [96]							

Bảng 5.2: Summary of the latest results with a coefficient 1 before  $\Delta$  in the upper bound of  $\chi^i$ .

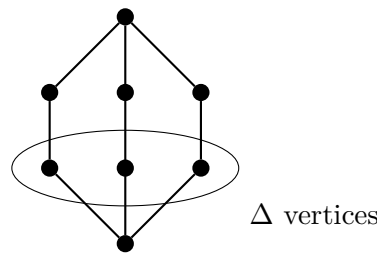

Hình 5.15: A graph with girth 6 and  $\chi^i \geq \Delta + 1$  (drawn for  $\Delta = 3$ ) [96].

Another natural relaxation in  $p$ -distance coloring is by replacing “at most” in the constraint that “every pair of vertices at distance at most  $p$  must receive distinct colors” by “exactly”. This gave birth to the study of *exact  $p$ -distance colorings* [101]. This parameter received an increasing attention in the last decade ([20, 59, 70, 103]). In [59], Foucaud et al. began the first systematic study of the exact square coloring (exact 2-distance coloring) with respect to the maximum degree. In their paper they considered the exact square coloring for some specific classes of subcubic graphs.

We denote  $\chi^{\#2}(G)$ , the *exact square chromatic number*, is the smallest integer  $k$  such that there exists an exact square coloring of  $G$  with  $k$  colors. By definition, an injective coloring is also an exact square coloring as vertices at distance 2 must share a common neighbor. Thus, exact square coloring is also a relaxation of injective coloring (see Figure 5.16 for examples of a comparison of these colorings). Hence, we obtain the following chain of inequalities:

$$\chi^{\#2}(G) \leq \chi^i(G) \leq \chi^2(G).$$

Moreover,  $\chi^{\#2}(G) = \chi^i(G)$  in the case of triangle-free graphs, i.e., graphs in which no pair of adjacent vertices share a common neighbor. Consequently, all the results in Table 5.2, except for the row corresponding to girth at least 3, also hold for exact square coloring.

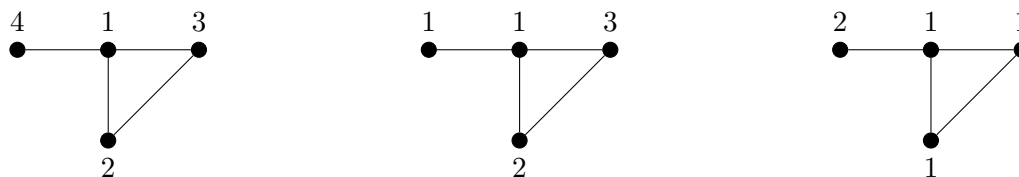

(i) A 2-distance coloring. (ii) An injective coloring. (iii) An exact square coloring.

Hình 5.16: A 2-distance coloring, injective coloring, and exact square coloring of the same graph.

Below are our results for injective and exact square colorings.

**Theorem 5.19** ([89]). If  $G$  is a planar graph with  $\Delta(G) = 4$ , then  $\chi_\ell^i(G) \leq \Delta(G) + 7$ .

**Theorem 5.20** ([89]). If  $G$  is a planar graph with  $g(G) \geq 4$  and  $\Delta(G) = 4$ , then  $\chi_\ell^{\#2}(G) = \chi_\ell^i(G) \leq \Delta(G) + 5$ .

**Theorem 5.21** ([89]). If  $G$  is a planar graph with  $\Delta(G) = 4$ , then  $\chi_\ell^{\#2}(G) \leq \Delta(G) + 6$ .

The proofs of these results rely heavily on faces of the considered planar graphs and none of them, even in their non-list version, can be extended to non-planar graphs as there exists a 4-regular bipartite graph on 26 vertices with  $\chi^2 = \chi^i = \chi^{\#2} = 13$  (see Figure 5.17). However, this graph has  $\text{mad} = 4$  while some of our results are on planar graphs with girth 4 which have  $\text{mad} < \frac{2 \cdot 4}{4-2} = 4$  so one might think that it might be extendable to graphs with  $\text{mad} < 4$ . Unfortunately, in this case, removing any vertex of the graph in Figure 5.17 will yield a graph with  $\text{mad} < 4$  and  $\chi^{\#2} \geq 12$ , which still proves that these results are “optimal” in the sense that planarity is needed not only for sparseness.

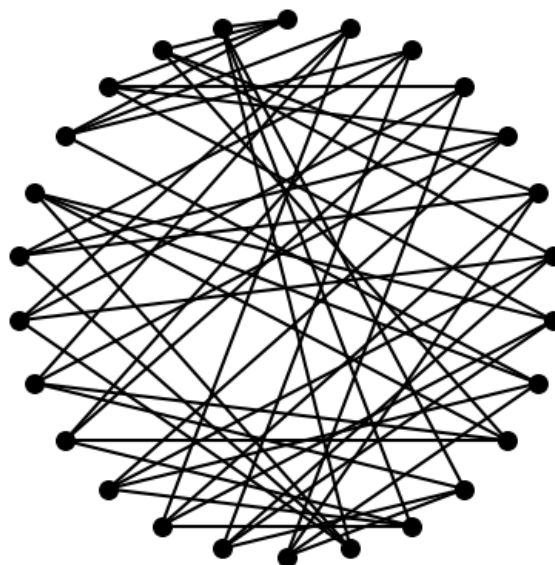

Hình 5.17: A 4-regular bipartite graph on 26 vertices with  $\chi^{\#2} = 13$ .

Graph6 string of the graph: Ys\_????????????GwA?wOGoco?WQ?gK?'I?G'0?d0?AIG?Ac\_?AX???

In this chapter, we will only present the proof of Theorem 5.20 as the other proofs also follow similar ideas. Every proof can be found in the Appendix.

Let  $G$  be a counterexample to Theorem 5.20 minimizing the number of edges plus vertices.



5.2.1 Structural properties of  $G$

In this section, we abuse the list notation  $L$  to mean the remaining list of colors for non-colored vertices in a precoloring of  $G$ .

Observe that since  $g(G) \geq 4$ , whenever two vertices are adjacent, they do not see each other (they do not share a common neighbor). Otherwise,  $G$  would contain a 3-cycle. As a result, an injective coloring of  $G$  is also an exact square coloring as only vertices at distance exactly 2 see each other.

**Lemma 5.22.**  $\delta(G) \geq 2$ .

*Chứng minh.* If  $G$  contains a 1-vertex  $v$ , then we can simply remove  $v$  and color the resulting graph, which is possible by minimality of  $G$ . Then, we add  $v$  back and extend the coloring, since  $v$  shares a neighbor with at most 3 other vertices and we have 9 colors in total.  $\square$

We do not have enough colors to reduce a 2-vertex directly. However, the presence of such a “small” vertex guarantees that its neighbors must have a large neighborhood. From now on, for every vertex  $u \in V(G)$ , we denote  $d^{\#2}(u)$  the number of vertices at distance exactly 2 from  $u$ .

**Lemma 5.23.** If a 4-vertex  $u$  in  $G$  is adjacent to a 2-vertex, then  $d^{\#2}(u) \geq 9$ .

*Chứng minh.* Suppose by contradiction that  $u$  is a 4-vertex that is adjacent to a 2-vertex  $v$  and  $d^{\#2}(u) \leq 8$ . Then, color  $G - \{v\}$  by minimality and uncolor  $u$ . Vertex  $u$  sees as many colors as  $d^{\#2}(u) \leq 8$ , so it is colorable. Finish by coloring  $v$  which sees only  $d^{\#2}(v) \leq 6$  colors.  $\square$

**Lemma 5.24.** Graph  $G$  cannot contain the following configurations:

- (i) Two adjacent  $3^-$ -vertices.
- (ii) A 4-vertex adjacent to two 2-vertices.
- (iii) A 4-vertex adjacent to a 2-vertex and two 3-vertices.
- (iv) A 2-vertex incident to a 4-cycle.
- (v) A 3-vertex incident to two 4-cycles.
- (vi) A 4-vertex  $u$  adjacent to a 2-vertex and a 3-vertex  $v$ , and  $uv$  is incident to a 4-cycle.

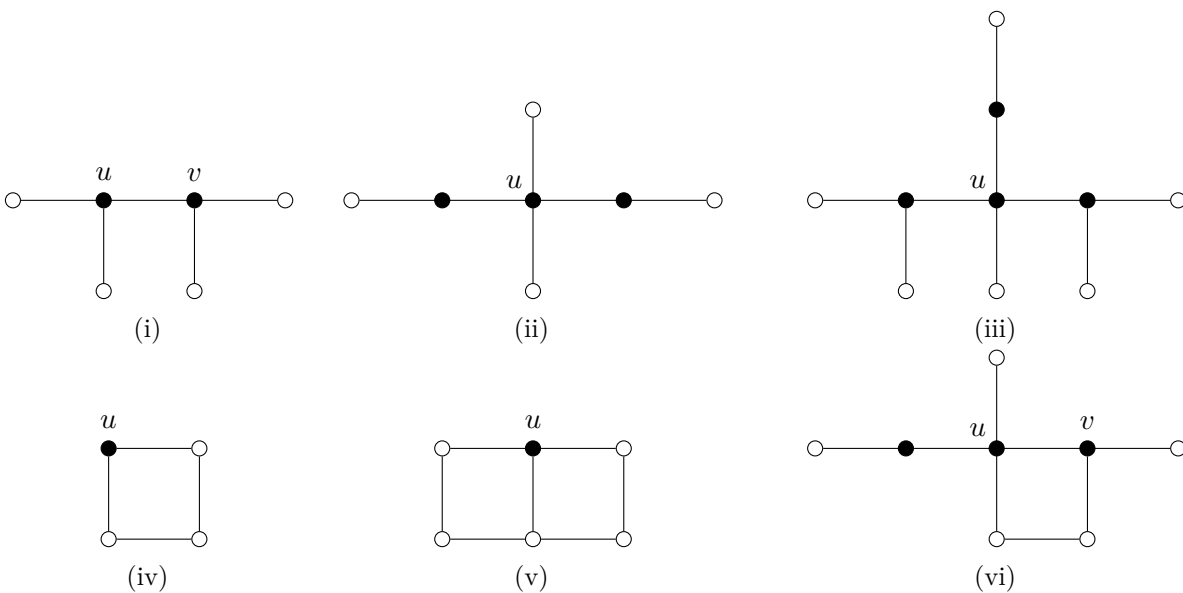

Hình 5.18: Reducible configurations in Lemma 5.24.

*Chứng minh.* We separate the proof into four parts based on the configurations.

- (i) Suppose by contradiction that there exist two adjacent  $3^-$ -vertices  $u$  and  $v$ . Color  $G - \{uv\}$  by minimality. Uncolor  $u$  and  $v$ . Observe that  $d^{\#2}(u) \leq 8$ . The same holds for  $v$ . Thus,  $u$  and  $v$  are colorable.
- (iv) Suppose by contradiction that there exists a 2-vertex  $u$  incident to a 4-cycle. Color  $G - \{u\}$  by minimality. Observe that the two neighbors of  $u$  will also have different colors in  $G$  since they are at distance 2 in  $G - \{u\}$ . Thus, we only need to color  $u$  which sees only  $d^{\#2}(u) \leq 5$  colors.
- (v) Suppose by contradiction that there exists a 3-vertex  $u$  incident to two 4-cycles. Let  $e$  be the edge incident to  $u$  that is incident to both cycles. Color  $G - \{e\}$  by minimality and uncolor  $u$ . Observe that every pair of neighbors of  $u$  are still at distance 2 in  $G - \{e\}$ . Thus, we only need to color  $u$  which sees only  $d^{\#2}(u) \leq 7$  colors.
- (ii), (iii), and (vi) Observe that the 4-vertex  $u$  with the 2-neighbor in these configurations always verifies  $d^{\#2}(u) \leq 8$ , which is impossible due to Lemma 5.23.

Thus, if  $G$  contains any of the above configurations, then  $\chi_\ell^i(G) \leq 9$ , a contradiction. □

Before continuing with proving some more structural results, we first give some additional useful definitions and observations.

**Definition 5.25** (Good and bad faces). We call a 5-face *bad* if it is incident to a 2-vertex and a 3-vertex. Additionally, we call a  $5^+$ -face *good*, if it is not a bad 5-face.

The following observation is a direct consequence of Lemma 5.24(i).

**Observation 5.26.** A 2-vertex and a 3-vertex on a bad 5-face  $f$  in  $G$  must be at distance 2 and they are the only  $3^-$ -vertices on  $f$ .

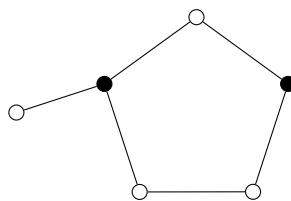

Hình 5.19: A bad face.

To further help us with the proofs, we now divide  $3^-$ -vertices into three different types.

**Definition 5.27** (Small, medium, and large  $3^-$ -vertices). We call a  $3^-$ -vertex *small*, if it is either a 2-vertex or a 3-vertex incident to a bad 5-face and a 4-face. A 3-vertex is called *medium*, if it is incident to either a bad 5-face or a 4-face. Finally, a 3-vertex is called *large*, if it is neither medium nor small.

Due to Lemma 5.24(vi) we have the following observation.

**Observation 5.28.** A 4-face in  $G$ , adjacent with a bad 5-face  $f$  and incident to a small 3-vertex  $v$ , cannot be incident to the common neighbor of  $v$  and the 2-vertex on  $f$ .

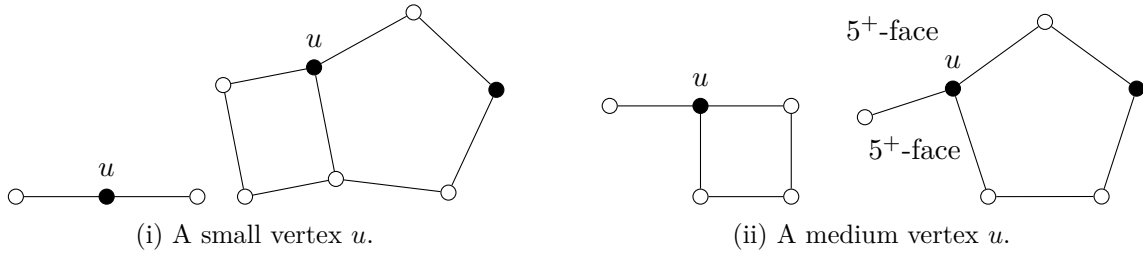

Hình 5.20: Small and medium  $3^-$ -vertices.

We are now ready to prove some structural properties regarding bad 5-faces.

**Lemma 5.29.** Let  $f = v_1v_2v_3v_4v_5$  be a bad 5-face in  $G$  where  $v_1$  is the 3-vertex and  $v_3$  is the 2-vertex. Let  $f' = v'_1v'_2v'_3v'_4v'_5 \neq f$  be another 5-face incident to  $v_1 = v'_1$ . Then, we have the following:

- If  $f'$  is incident to  $v_1v_2$ , then  $f'$  does not contain any other  $3^-$ -vertices (distinct from  $v_1$ ).
- If  $f'$  is incident to  $v_1v_5$ , then  $f'$  does not contain any other small vertices (distinct from  $v_1$ ).

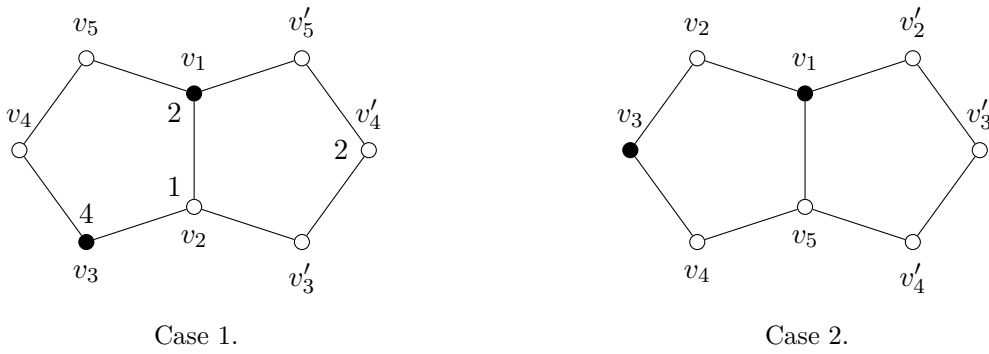

Hình 5.21: Reducible configurations from Lemma 5.29.

*Chứng minh.* We assume w.l.o.g. that  $v'_1 = v_1$ . Since  $g(G) \geq 4$ , every vertex of  $f$  and  $f'$  (except for the two common vertices that are  $v_1$  and one of its neighbor) is distinct.

Suppose by contradiction that  $f'$  contains (another) small vertex different from  $v_1$ .

**Case 1:** Suppose  $f'$  is incident to  $v_1v_2$ , say  $v'_2 = v_2$ . First, observe that  $d(v'_3) = 4$  due to Lemma 5.24(iii) and  $d(v'_5) = 4$  due to Lemma 5.24(i). Thus,  $v'_4$  must be a  $3^-$ -vertex. Color  $G - \{v_3\}$  and uncolor  $v_1, v_2$ , and  $v'_4$ . Observe that  $|L(v_1)| \geq 2, |L(v_2)| \geq 1, |L(v_3)| \geq 4, |L(v'_4)| \geq 2$ . Therefore, we can color  $v_2, v'_4, v_1$ , and  $v_3$  in this order.

**Case 2:** Suppose  $f'$  is incident to  $v_1v_5$ , say  $v'_5 = v_5$ . By Lemma 5.24(i),  $v'_2$  cannot be a small vertex, and at most one of  $v'_3$  and  $v'_4$  can be. Thus, we have the following two cases:

- If  $v'_4$  is a  $3^-$ -vertex, then color  $G - \{v_3\}$  and uncolor  $v_1, v_4$ , and  $v'_4$ . Observe that  $|L(v_1)| \geq 3, |L(v_4)| \geq 1, |L(v_3)| \geq 4, |L(v'_4)| \geq 2$ . Therefore, we can color  $v_4, v'_4, v_1$ , and  $v_3$  in this order.
- If  $v'_3$  is a  $3^-$ -vertex, then recall that  $v'_3$  is a small vertex.
  - If  $v'_3$  is a small 3-vertex, then it is incident to a bad 5-face  $f'' \neq f'$  (since  $f'$  is a good face) and a 4-face. If  $f''$  is incident to  $v'_2v'_3$ , then the 4-face must be incident to  $v'_3v'_4$ . By Lemma 5.24(iii, vi),  $f''$  cannot be incident to a 2-vertex, which is a contradiction. Thus,  $f''$  must be incident to  $v'_3v'_4$ . By Lemma 5.24(vi), the 2-vertex incident to  $f''$  must be adjacent to  $v'_4$ . However, in this case, we can use the same proof as in **Case 1** from the point of view of  $v'_3, f''$ , and  $f'$  instead.

- If  $v'_3$  is a 2-vertex, then we color  $G - \{v_3\}$  and uncolor every vertex on  $f$  and  $f'$ . Observe that the remaining list of colors for these vertices have size:  $|L(v_1)| \geq 5$ ,  $|L(v_2)| \geq 3$ ,  $|L(v_3)| \geq 5$ ,  $|L(v_4)| \geq 2$ ,  $|L(v_5)| \geq 2$ ,  $|L(v'_2)| \geq 3$ ,  $|L(v'_3)| \geq 5$ , and  $|L(v'_4)| \geq 2$ . Moreover, if we can color  $v_2, v_4, v_5, v'_2$ , and  $v'_4$ , then we can always finish by coloring  $v_1, v'_3$ , and  $v_3$  in this order.

If  $L(v_4)$  and  $L(v_5)$  have a common color  $c$ , then we color them with  $c$  and color  $v'_4, v_2$ , and  $v'_2$  in this order. The same holds for  $L(v'_4)$  and  $L(v_5)$ . As a result,  $|L(v_4) \cup L(v_5)| \geq 4$  and  $|L(v'_4) \cup L(v_5)| \geq 4$ .

If  $L(v_4)$  and  $L(v'_2)$  have a common color  $c$ , then we proceed as follows. Suppose  $v_4$  and  $v'_2$  do not see each other, then we color them with  $c$ . Recall that  $L(v'_4) \cap L(v_5) = \emptyset$ . So, we can color  $v'_4, v_2$ , and  $v_5$  in this order. The same holds for  $L(v'_4)$  and  $L(v_2)$ . As a result, if  $L(v_4)$  and  $L(v'_2)$  share a color, then  $v_4$  must see  $v'_2$ . The same holds for  $v'_4$  and  $v_2$ . By planarity,  $v_2, v_4, v'_2$ , and  $v'_4$  must share a common neighbor  $u$ . However, this is impossible since  $v_3$  would be a 2-vertex incident to the 4-cycle  $v_2v_3v_4u$  contradicting Lemma 5.24(iv). Finally, we must have  $|L(v_4) \cup L(v'_2)| \geq 5$  or  $|L(v'_4) \cup L(v_2)| \geq 5$ .

Finally, we have  $|L(v_4) \cup L(v_5)| \geq 4$ ,  $|L(v'_4) \cup L(v_5)| \geq 4$ , and at least one of the following two inequalities:  $|L(v_4) \cup L(v'_2)| \geq 5$  or  $|L(v'_4) \cup L(v_2)| \geq 5$ . Therefore, we can always color  $v_2, v_4, v_5, v'_2$ , and  $v'_4$  by Hall's theorem.

Thus, we can conclude that  $\chi_\ell^i(G) \leq 9$ , a contradiction.  $\square$

Finally, we show that small vertices cannot be close to each other from the perspective of a face of size at least 6.

**Definition 5.30** (Facial-distance). Let  $f = u_1u_2 \dots u_{d(f)}$  be a face in  $F(G)$ , and let  $u_i$  and  $u_j$  be vertices incident to  $f$ . The facial-distance on  $f$  between  $u_i$  and  $u_j$  is their distance on the cycle  $u_1u_2 \dots u_{d(f)}$  (which is  $\min(i - j \pmod{d(f)}, j - i \pmod{d(f)})$ ).

**Lemma 5.31.** Two small vertices incident to a same  $6^+$ -face  $f$  in  $G$  are at facial-distance at least 3 on  $f$ .

*Chứng minh.* By Lemma 5.24(i), small vertices cannot be adjacent. By Lemma 5.24(ii), two 2-vertices must be at distance at least 3. We only need to check if a small 3-vertex and a 2-vertex, or two small 3-vertices can be at facial-distance 2 on  $f$ . Let  $f = v_1v_2v_3v_4 \dots$  is a  $6^+$ -face.

Suppose that  $v_1$  is a 2-vertex and  $v_3$  a small 3-vertex. Observe that  $v_2v_3$  cannot be incident to a 4-face by Lemma 5.24(vi), so  $v_3v_4$  must be incident to a 4-face and  $v_2v_3$  is incident to a bad 5-face (different from  $f$  since  $f$  is a  $6^+$ -face). However, due to Lemma 5.24(ii, vi), the bad 5-face incident to  $v_2v_3$  cannot be incident to a 2-vertex, which is a contradiction.

Now, suppose that  $v_1$  and  $v_3$  are small 3-vertices. They must both be incident to some 4-faces and bad 5-faces. If  $v_3v_4$  is incident to a 4-face, then  $v_2v_3$  must be incident to a bad 5-face. However, by Lemma 5.24(i, iii, vi), this 5-face cannot be incident to any 2-vertex. As a result,  $v_2v_3$  must be incident to a 4-face. By symmetry,  $v_1v_2$  is also incident to a 4-face. Additionally,  $v_3v_4$  must be incident to a bad 5-face. By Lemma 5.24(vi), the 2-vertex  $u$  on this bad 5-face must be adjacent to  $v_4$ . Now, color  $G - \{u\}$  and uncolor  $v_4$  and  $v_2$ . Observe that  $|L(v_4)| \geq 1$ ,  $|L(v_2)| \geq 2$ , and  $|L(u)| \geq 3$ . Thus, we can finish by coloring  $v_4, v_2$ , and  $v_3$  in this order.  $\square$

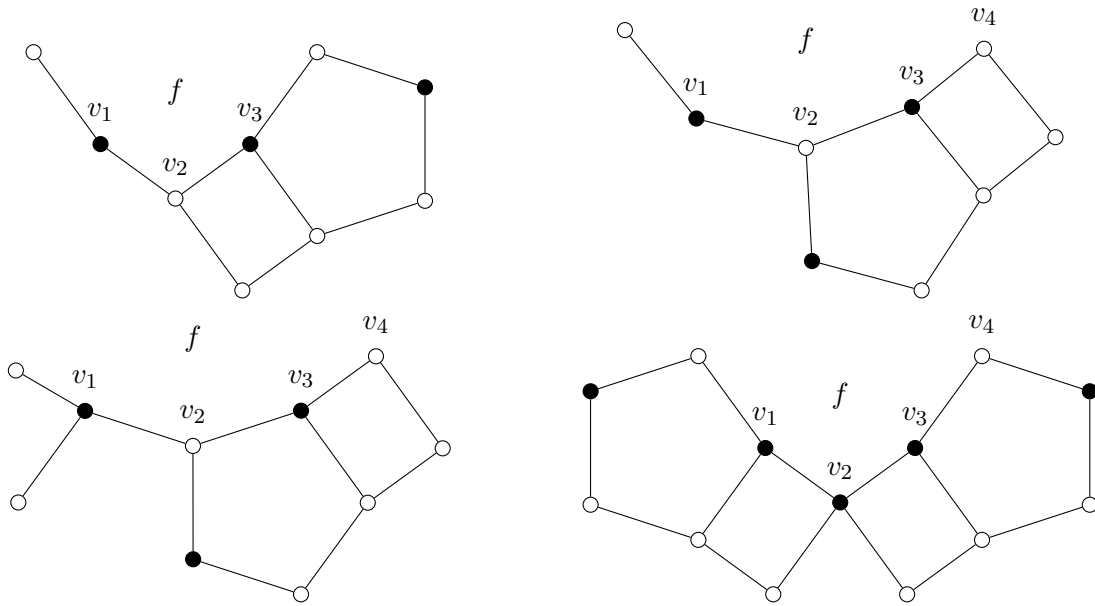

Hình 5.22: Reducible configurations in Lemma 5.31.

### 5.2.2 Discharging procedure

We assign to each vertex the charge  $\mu(v) = d(v) - 4$ , and to each face  $\mu(f) = d(f) - 4$ . By Euler's formula, we have  $\sum_{v \in V(G)} \mu(v) + \sum_{f \in F(G)} \mu(f) = -8$ . To get a contradiction, we apply the following rules in the discharging procedure:

- R0** Every  $5^+$ -face  $f$  gives 1 to each 2-vertex.
- R1** Every good  $5^+$ -face  $f$  gives 1 to each small 3-vertex.
- R2** Every good  $5^+$ -face  $f$  gives  $\frac{1}{2}$  to each medium 3-vertex.
- R3** Every  $5^+$ -face  $f$  gives  $\frac{1}{3}$  to each large 3-vertex.

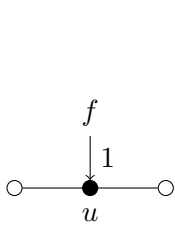

Hình 5.23: **R0.**

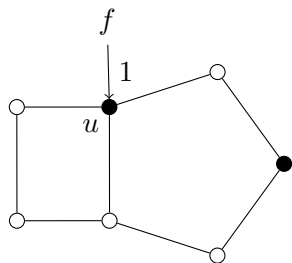

Hình 5.24: **R1.**

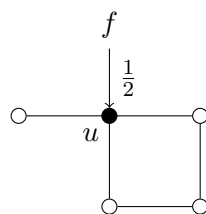

Hình 5.25: **R2.**

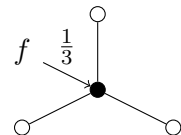
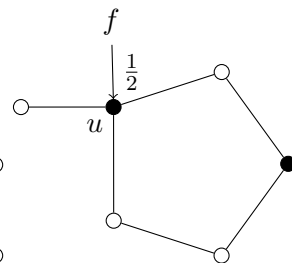

Hình 5.26: **R3.**

Let  $\mu^*$  be the assigned charges after the discharging procedure. In what follows, we will prove that:

$$\forall x \in V(G) \cup F(G), \mu^*(x) \geq 0.$$

### Vertices

Let  $u$  be a vertex in  $V(G)$ . Vertex  $u$  has degree at least 2 by Lemma 5.22. Recall that  $\Delta(G) = 4$  and  $\mu(u) = d(u) - 4$ .

**Case 1:** If  $d(u) = 4$ , then  $u$  does not give any charge. So,

$$\mu^*(u) = \mu(u) = d(u) - 4 = 0.$$

**Case 2:** If  $d(u) = 3$ , then  $\mu(u) = d(u) - 4 = -1$  and we have the following cases:

- If  $u$  is a small 3-vertex, then  $u$  is incident to one good  $5^+$ -face due to Lemma 5.24(v) and Lemma 5.29. By **R1**, we have

$$\mu^*(u) \geq -1 + 1 = 0.$$

- If  $u$  is a medium 3-vertex, then it is incident to two good  $5^+$ -faces due to Lemma 5.24(v) and Lemma 5.29. By **R2**, we have

$$\mu^*(u) \geq -1 + 2 \cdot \frac{1}{2} = 0.$$

- If  $u$  is a large 3-vertex, then by definition,  $u$  is incident to only  $5^+$ -face. Thus, by **R3**, we have

$$\mu^*(u) \geq -1 + 3 \cdot \frac{1}{3} = 0.$$

**Case 3:** If  $d(u) = 2$ , then  $u$  has to be incident to only  $5^+$ -faces due to Lemma 5.24(iv). By **R0**, we have

$$\mu^*(u) \geq 2 - 4 + 2 \cdot 1 = 0.$$

## Faces

Let  $f$  be a face in  $F(G)$ . Recall that  $\mu(f) = d(f) - 4$  and  $d(f) \geq 4$  since  $g(G) \geq 4$ . Let  $i_0$ ,  $i_1$ ,  $i_2$ , and  $i_3$  be respectively the number of times  $f$  gives charge by **R0**, **R1**, **R2**, and **R3**. We distinguish the following cases.

**Case 1:**  $d(f) \geq 7$

Let  $u$  and  $v$  be two small vertices on  $f$ . By Lemma 5.31,  $u$  and  $v$  must be at facial-distance at least 3 on  $f$ . As a result, the neighbors of  $u$  and  $v$  on  $f$  are distinct. Moreover, due to Lemma 5.24(i), those neighbors are 4-vertices. Thus, we also have  $i_2 + i_3 \leq d(f) - 3(i_0 + i_1)$ . Due to Lemma 5.24(i), we also have  $i_2 + i_3 \leq \frac{1}{2}d(f)$ . Consequently,  $i_2 + i_3 \leq \min(d(f) - 3(i_0 + i_1), \frac{1}{2}d(f))$ .

We claim that  $f$  gives at most  $\frac{5}{12}d(f)$  charge away. Indeed, recall that  $f$  gives  $i_0 + i_1 + \frac{1}{2}i_2 + \frac{1}{3}i_3$  by **R0**, **R1**, **R2**, and **R3**. By the above inequalities,

- if  $d(f) - 3(i_0 + i_1) \leq \frac{1}{2}d(f)$ , then  $i_0 + i_1 \geq \frac{1}{6}d(f)$ . Moreover, we get

$$\begin{aligned} i_0 + i_1 + \frac{1}{2}i_2 + \frac{1}{3}i_3 &\leq i_0 + i_1 + \frac{1}{2}(i_2 + i_3) \\ &\leq i_0 + i_1 + \frac{1}{2}(d(f) - 3(i_0 + i_1)) \\ &\geq \frac{1}{2}(d(f) - (i_0 + i_1)) \\ &\geq \frac{1}{2}(d(f) - \frac{1}{6}d(f)) \\ &\geq \frac{5}{12}d(f) \end{aligned}$$

- if  $d(f) - 3(i_0 + i_1) > \frac{1}{2}d(f)$ , then  $i_0 + i_1 < \frac{1}{6}d(f)$ . Moreover, we get

$$\begin{aligned} i_0 + i_1 + \frac{1}{2}i_2 + \frac{1}{3}i_3 &\leq i_0 + i_1 + \frac{1}{2}(i_2 + i_3) \\ &\leq \frac{1}{6}d(f) + \frac{1}{2} \cdot \frac{1}{2}d(f) \\ &\geq \frac{5}{12}d(f) \end{aligned}$$

To conclude, we have

$$\mu^*(f) \geq d(f) - 4 - \frac{5}{12}d(f) \geq \frac{7}{12}d(f) - 4 \geq 0$$

since  $d(f) \geq 7$ .

**Case 2:**  $d(f) = 6$

Similar to the previous case, two small vertices cannot be at facial-distance 2 on  $f$  by Lemma 5.31. As a result, we get  $i_0 + i_1 \leq 2$ . Moreover, by Lemma 5.24(i), two  $3^-$ -vertices cannot be adjacent, so we get  $i_0 + i_1 + i_2 + i_3 \leq 3 \Leftrightarrow i_2 + i_3 \leq 3 - (i_0 + i_1)$ . Now, we distinguish the following cases.

- Suppose  $i_0 + i_1 = 2$ . Observe that, since small vertices cannot share neighbors on  $f$  and their neighbors are all 4-vertices, we have exactly two  $3^-$ -vertices on  $f$ . In other words,  $i_2 + i_3 = 0$ . Recall that  $\mu(f) = d(f) - 4 = 2$  and that  $f$  gives  $i_0 + i_1 + \frac{1}{2}i_2 + \frac{1}{3}i_3$  by **R0**, **R1**, **R2**, and **R3**. Thus,

$$\mu^*(f) \geq 2 - (i_0 + i_1 + \frac{1}{2}i_2 + \frac{1}{3}i_3) = 2 - 2 + 0 = 0.$$

- Suppose  $i_0 + i_1 \leq 1$ . We get

$$\mu^*(f) \geq 2 - (i_0 + i_1 + \frac{1}{2}i_2 + \frac{1}{3}i_3) \geq 2 - (i_0 + i_1 + \frac{1}{2}(3 - (i_0 + i_1))) \geq \frac{1}{2} - \frac{1}{2}(i_0 + i_1) \geq 0.$$

**Case 3:**  $d(f) = 5$

Recall that  $\mu(f) = d(f) - 4 = 1$ . Observe that we have the following inequalities.

- $i_0 + i_1 + i_2 + i_3 \leq 2$  since there are no adjacent  $3^-$ -vertices by Lemma 5.24(i).
- $i_0 \leq 1$  due to Lemma 5.24(ii).
- $i_1 \leq 1$  due to Lemma 5.29.

Recall that  $f$  gives  $i_0 + i_1 + \frac{1}{2}i_2 + \frac{1}{3}i_3$ .

- If  $i_0 = 1$ , then either  $f$  is incident to a 3-vertex, in which case, it is a bad 5-face and **R1**, **R2**, **R3** do not apply (by definition of a bad face), or it is not incident to any 3-vertex. In both cases,  $i_1 + i_2 + i_3 = 0$ . So,

$$\mu^*(f) \geq 1 - (i_0 + i_1 + \frac{1}{2}i_2 + \frac{1}{3}i_3) \geq 1 - (1 + 0) = 0.$$

- If  $i_0 = 0$  and  $i_1 = 1$ , then  $f$  cannot be incident to any other (than the small 3-vertex)  $3^-$ -vertices due to Lemma 5.29. As a result,  $i_2 + i_3 = 0$ . So,

$$\mu^*(f) \geq 1 - (i_0 + i_1 + \frac{1}{2}i_2 + \frac{1}{3}i_3) \geq 1 - (1 + 0) = 0.$$

- If  $i_0 = i_1 = 0$ , then

$$\mu^*(f) \geq 1 - (i_0 + i_1 + \frac{1}{2}i_2 + \frac{1}{3}i_3) \geq 1 - (0 + \frac{1}{2} \cdot 2) = 0.$$

**Case 4:**  $d(f) = 4$

Recall that  $\mu(f) = d(f) - 4 = 0$ . Since  $f$  does not give any charge, we have

$$\mu^*(f) = \mu(f) = 0.$$

We started with a negative total charge, but after the discharging procedure, which preserved the total sum, we end up with a non-negative total sum. In other words, there exist no counterexamples to Theorem 5.20.

# Chương 6

## Conclusion

In this thesis, we discussed two main aspects of the problem of 2-distance coloring of sparse graphs: the technical aspects of the proofs that relate more to the class of graphs, and the difficulty of understanding the behavior of 2-distance coloring.

Starting with the proof techniques, in Chapter 2, the potential method helped more configurations, thus improving the previously known results. However, our usage of the potential function remains quite rudimentary as it is only a reformulation of the constraint on the maximum average degree. It is also only related to the class of graphs (with bounded maximum average degree) and does not exploit the properties of the coloring. Designing a better suited potential function by using knowledge of critical graphs for the parameters of the coloring (see for instance [37]) seems to be the next step in this direction.

In Chapter 3, we exploited the presence of faces in planar graphs with the help of computer assistance. It seems very natural to apply these ideas to graphs that are embeddable on orientable surfaces with a higher genus. For these classes of graphs, Euler's formula ( $|V| - |E| + |F| = 2 - 2\gamma$  where  $\gamma$  is the genus of the graph) also provides a bound on the number of edges compared to the number of vertices and faces in the graph, which lends itself well to using the discharging method.

Recently, Bousquet *et al.* [19] proposed a linear programming approach to automatically look for a discharging proof. Similar to our algorithm, this implementation can return a set of to-be-reduced configurations that will help with the research process and there are also restrictions on the type of rules that can be implemented. In our case, there are less constraints on the set of rules that can be defined and the algorithm consists in generating all cases and verifying if such set suffices. Whereas, the upside of algorithm in [19] is the capability of finding the rules automatically. However, this process is not fully autonomous as part of the rules has to be decided manually to limit the number of cases the algorithm has to go through. While these ideas of automatic discharging only work for colorings with local constraints, they contribute towards the next step for the discharging method: automatic proofs.

For 2-distance coloring, in Chapter 4, we discussed how there was a lack of constructions of planar graphs with high 2-distance chromatic number which fundamentally stems from a lack of understanding of the behavior of this type of coloring. Since the intuition for Wegner's Conjecture comes from planar graphs with diameter 2, the next step towards a better understanding of the coloring and towards proving the conjecture in the general case is to study the 2-distance chromatic number of planar graphs with a fixed diameter.

Either confirming or disproving Wegner's Conjecture for 2-distance coloring of planar graphs will also provide a better insight into general distance coloring and get us closer to answering another one of Wegner's Conjectures:

**Conjecture 6.1** ([117]). For all integers  $k \geq 1$  and  $\Delta \geq 3$ ,

$$\max_{\{G|\Delta(G)=\Delta\}} \chi^k(G) = \max_{\{G|\Delta(G)=\Delta\}} \omega(G^k).$$



While Conjecture 6.1 holds for  $k = 1$  thanks to Brook's theorem (Theorem 1.2), the case  $k = 2$  is only solved for  $\Delta \in \{2, 3, 4, 5, 7\}$  [39].

Moreover, the same type of question can be asked for exact distance coloring. In this context, we have the following trivial upper bound: for any graph  $G$ ,  $\omega(G^{\#2}) \leq \Delta^2(G) - \Delta(G) + 1$ . The existence of graphs reaching this upper bound is still an open question for  $\Delta \geq 11$  [92]. Additionally, the existence of these graphs is equivalent to the existence of finite projective geometries [60] which are conjectured to exist only when  $\Delta + 1$  is a prime number.

# Tài liệu tham khảo

- [1] V. A. Aksenov. On continuation of 3-colouring of planar graphs (in Russian). *Diskret. Anal. Novosibirsk*, 26:3–19, 1974.
- [2] M.O. Albertson and D.M. Berman. A conjecture on planar graphs. *Graph Theory and Related Topics (J.A. Bondy and U.S.R. Murty, eds.)*, 1976.
- [3] K. Appel and W. Haken. Every planar map is four colorable. part I. discharging. *Illinois Journal of Mathematics*, 21:429–490, 1977.
- [4] K. Appel, W. Haken, and J. Koch. Every planar map is four colorable. part II. reducibility. *Illinois Journal of Mathematics*, 21:491–567, 1977.
- [5] V. Bartier, L. Bénéteau, M. Bonamy, H. La, and J. Narboni. A note on deterministic zombies. *Discrete Applied Mathematics*, 301:65–68, 2021.
- [6] M. Bonamy, D. Cranston, and L. Postle. Planar graphs of girth at least five are square  $(\Delta + 2)$ -choosable. *Journal of Combinatorial Theory, Series B*, 134:218–238, 2019.
- [7] M. Bonamy, B. Lévêque, and A. Pinlou. 2-distance coloring of sparse graphs. *Journal of Graph Theory*, 77(3), 2014.
- [8] M. Bonamy, B. Lévêque, and A. Pinlou. Graphs with maximum degree  $\Delta \geq 17$  and maximum average degree less than 3 are list 2-distance  $(\Delta + 2)$ -colorable. *Discrete Mathematics*, 317:19–32, 2014.
- [9] Anthony Bonato. *The game of cops and robbers on graphs*. American Mathematical Soc., 2011.
- [10] Anthony Bonato. What is...cop number? *Notices of the American Mathematical Society*, 59:1100–1101, 2012.
- [11] Anthony Bonato and Paweł Prałat. *Graph searching games and probabilistic methods*. CRC Press, 2017.
- [12] O. V. Borodin. A proof of Grünbaum’s conjecture on the acyclic 5-colorability of planar graphs. *Sov. Math., Dokl.*, 17:1499–1502, 1976.
- [13] O. V. Borodin. Colorings of plane graphs: A survey. *Discrete Math.*, 313(4):517–539, 2013.
- [14] O. V. Borodin and A. O. Ivanova. List injective colorings of planar graphs. *Discrete Mathematics*, 311:154–165, 2 2011.
- [15] O. V. Borodin, A. V. Kostochka, B. Lidický, and M. Yancey. Short proofs of coloring theorems on planar graphs. *Europ. J. Combin.*, 36:314–321, 2014.
- [16] O.V. Borodin and A.O. Ivanova. List 2-facial 5-colorability of plane graphs with girth at least 12. *Discrete Mathematics*, 312:306–314, 2012.

- [17] M. Borowiecki, E. Drgas-Burchardt, and E. Sidorowicz. A feedback vertex set of 2-degenerate graphs. *Theor. Comput. Sci.*, 557:50–58, 2014.
- [18] N. Bousquet, L. d. Meyer, Q. Deschamps, and T. Pierron. Square coloring planar graphs with automatic discharging. *arXiv*, page 2204.05791, 2022.
- [19] N. Bousquet, L. d. Meyer, Q. Deschamps, and T. Pierron. Square coloring planar graphs with automatic discharging. *arXiv*, page 2204.05791, 2022.
- [20] N. Bousquet, L. Esperet, A. Harutyunyan, and R. de Joannis de Verclos. Exact distance colouring in trees. *Combinatorics, Probability and Computing*, 28(2):177–186, 2019.
- [21] B. Brimkov, J. Edmond, R. Lazar, B. Lidický, K. Messerschmidt, and S. Walker. Injective choosability of subcubic planar graphs with girth 6. *Discrete Mathematics*, 340:2538–2549, 10 2017.
- [22] R. L. Brooks. On colouring the nodes of a network. *Mathematical Proceedings of the Cambridge Philosophical Society*, 37(2):194–197, 1941.
- [23] Y. Bu and C. Huang. List injective coloring of a class of planar graphs without short cycles. *Discrete Mathematics, Algorithms and Applications*, 10(5), 2018.
- [24] Y. Bu, X. Lv, and X. Yan. The list 2-distance coloring of a graph with  $\Delta(G) = 5$ . *Discrete Mathematics, Algorithms and Applications*, 7(2):1550017, 2015.
- [25] Y. Bu and C. Shang. List 2-distance coloring of planar graphs without short cycles. *Discrete Mathematics, Algorithms and Applications*, 8(1):1650013, 2016.
- [26] Y. Bu and J. Zhu. *Channel Assignment with  $r$ -Dynamic Coloring: 12th International Conference, AAIM 2018, Dallas, TX, USA, December 3–4, 2018, Proceedings*, pages 36–48. 2018.
- [27] Y. Bu and J. Zhu. List  $r$ -dynamic coloring of graphs with small maximum average degree. *Discrete Applied Mathematics*, 258:254–263, 2019.
- [28] Y. Bu and X. Zhu. An optimal square coloring of planar graphs. *Journal of Combinatorial Optimization*, 24:580–592, 2012.
- [29] Yuehua Bu and K. A.I. Lu. Injective coloring of planar graphs with girth 7. *Discrete Mathematics, Algorithms and Applications*, 4, 6 2012.
- [30] Yuehua Bu and Kai Lu. List injective coloring of planar graphs with girth 5, 6, 8. *Discrete Applied Mathematics*, 161:1367–1377, 7 2013.
- [31] Yuehua Bu, Kai Lu, and Sheng Yang. Two smaller upper bounds of list injective chromatic number. *Journal of Combinatorial Optimization*, 29:373–388, 2 2015.
- [32] M. Chen, G. Hahn, A. Raspaud, and W. Wang. Some results on the injective chromatic number of graphs. *Journal of Combinatorial Optimization*, 24:299–318, 10 2012.
- [33] Y. Chen, S. Fan, H.-J. Lai, H. Song, and L. Sun. On dynamic coloring for planar graphs of higher genus. *Discrete Applied Mathematics*, 160:1064–1071, 2012.
- [34] J. Cheng, H.-J. Lai, K.J. Lorenzen, R. Luo, J.C. Thompson, and C.-Q. Zhang.  $r$ -hued coloring of sparse graphs. *Discrete Applied Mathematics*, 237:75–81, 2018.
- [35] V. Cohen-Addad, M. Hebdige, Daniel Král', Z. Li, and E. Salgado. Steinberg's Conjecture is false. *J. Combin. Theory Ser. B*, 122:452–456, 2017.

- [36] D. Cranston, R. Eрман, and R. Škrekovski. Choosability of the square of a planar graph with maximum degree four. *Australasian Journal of Combinatorics*, 59(1):86–97, 2014.
- [37] D. Cranston and M. Yancey. Vertex partitions into an independent set and a forest with each component small. *SIAM Journal on Discrete Mathematics*, 35(3):1769–1791, 2021.
- [38] D. W. Cranston, S. Jin. Kim, and G. Yu. Injective colorings of graphs with low average degree. *Algorithmica*, 60:553–568, 7 2011.
- [39] D. W. Cranston and L. Rabern. Painting squares in  $\Delta^2 - 1$  shades. *The Electronic Journal of Combinatorics*, 23(2):P2.50, 2016.
- [40] D. W. Cranston and D. B. West. An introduction to the discharging method via graph coloring. *Discrete Mathematics*, 340(4):766–793, 2017.
- [41] Daniel W. Cranston, Seog Jin Kim, and Gexin Yu. Injective colorings of sparse graphs. *Discrete Mathematics*, 310:2965–2973, 11 2010.
- [42] Y. Dai, J. Lin, and Y. Yang. Largest planar graphs and largest maximal planar graphs of diameter two. *Journal of Computational and Applied Mathematics*, 144(1):349–358, 2002.
- [43] D. P. Dailey. Uniqueness of colorability and colorability of planar 4-regular graphs are NP-complete. *Discrete Math.*, 30(3):289–293, 1980.
- [44] W. Dong and W. Lin. Injective coloring of planar graphs with girth 6. *Discrete Mathematics*, 313:1302–1311, 2013.
- [45] W. Dong and W. Lin. Injective coloring of plane graphs with girth 5. *Discrete Mathematics*, 315-316:120–127, 2014.
- [46] W. Dong and W. Lin. An improved bound on 2-distance coloring plane graphs with girth 5. *Journal of Combinatorial Optimization*, 32(2):645–655, 2016.
- [47] W. Dong and W. Lin. On 2-distance coloring of plane graphs with girth 5. *Discrete Applied Mathematics*, 217:495–505, 2017.
- [48] W. Dong and B. Xu. 2-distance coloring of planar graphs with girth 5. *Journal of Combinatorial Optimization*, 34:1302–1322, 2017.
- [49] A. Doyon, G. Hahn, and A. Raspaud. Some bounds on the injective chromatic number of graphs. *Discrete Mathematics*, 310:585–590, 2 2010.
- [50] Z. Dvořák, D. Král, and R. Thomas. Three-coloring triangle-free graphs on surfaces V. Coloring planar graphs with distant anomalies. *J. Combin. Theory Ser. B*, 150:244–269, 2021.
- [51] Z. Dvořák, D. Král, P. Nejedlý, and R. Škrekovski. Coloring squares of planar graphs with girth six. *European Journal of Combinatorics*, 29(4):838–849, 2008.
- [52] Z. Dvořák, R. Škrekovski, and M. Tancer. List-coloring squares of sparse subcubic graphs. *SIAM Journal on Discrete Mathematics*, 22(1):139–159, 2008.
- [53] P. Erdős and L. Moser. On the representation of directed graphs as unions of orderings. *Magyar Tud. Akad. Mat. Kutató Int. Közl.*, 9:125–132, 1964.
- [54] P. Erdős. Graph theory and probability. *Canadian Journal of Mathematics*, 11:34–38, 1959.

- [55] P. Erdős, A. L. Rubin, and H. Taylor. Choosability in graphs. *Proc. West Coast Conf. on Combinatorics, Graph Theory and Computing, Congressus Numerantium XXVI*, pages 125–157, 1979.
- [56] M. R. Fellows, P. Hell, and K. Seyffarth. Constructions of large planar networks with given degree and diameter. *Networks*, 32(4):275–281, 1998.
- [57] G. Fertin, E. Godard, and A. Raspaud. Minimum feedback vertex set and acyclic coloring. *Inf. Process. Lett.*, 84(3):131–139, 2002.
- [58] Shannon L Fitzpatrick, Jared Howell, Margaret-Ellen Messinger, and David A Pike. A deterministic version of the game of zombies and survivors on graphs. *Discrete Applied Mathematics*, 213:1–12, 2016.
- [59] F. Foucaud, H. Hocquard, S. Mishra, N. Narayanan, R. Naserasr, É. Sopena, and P. Valicov. Exact square coloring of subcubic planar graphs. *Discrete Applied Mathematics*, 293:74–89, 2021.
- [60] F. Foucaud, S. Mishra, N. Narayanan, R. Naserasr, and P. Valicov. Cliques in exact distance powers of graphs of given maximum degree. *Procedia Computer Science*, 195:427–436, 2021.
- [61] G. Gonthier. Formal proof—the four-color theorem. *Notices of the AMS*, 55(11):1382–1393, 2008.
- [62] H. Grötzsch. Ein Dreifarbensatz für dreikreisfreie Netze auf der Kugel. *Wiss. Z. Martin-Luther-Univ. Halle-Wittenberg Math.-Natur.*, 8:109–120, 1959.
- [63] B. Grünbaum. Grötzsch’s theorem on 3-coloring. *Michigan Math. J.*, 10:303–310, 1963.
- [64] G. Hahn, J. Kratochvíl, J. Širáň, and D. Sotteau. On the injective chromatic number of graphs. *Discrete Mathematics*, 256:179–192, 2002.
- [65] P. Hall. On Representatives of Subsets. *J. Lond. Math. Soc.*, s1–10(1):26–30, 1935.
- [66] S.G. Hartke, S. Jahanbekam, and B. Thomas. The chromatic number of the square of subcubic planar graphs. arXiv:1604.06504, 2018.
- [67] I. Havel. On a Conjecture of B. Grünbaum. *J. Combin. Theory Ser. B*, 7:184–186, 1969.
- [68] F. Havet, J. Van Den Heuvel, C. McDiarmid, and B. Reed. List colouring squares of planar graphs. arXiv:0807.3233, 2017.
- [69] P. J. Heawood. On the four-colour map theorem. *Quart. J. Pure Appl. Math.*, 29:270–285, 1898.
- [70] J. van den Heuvel, H. A. Kierstead, and D. A. Quiroz. Chromatic numbers of exact distance graphs. *Journal of Combinatorial Theory, Series B*, 134:143–163, 2018.
- [71] A. J. Hoffman and R. R. Singleton. On moore graphs with diameters 2 and 3. *IBM Journal*, 4:497–504, 1960.
- [72] A.O. Ivanova. List 2-distance  $(\Delta+1)$ -coloring of planar graphs with girth at least 7. *Journal of Applied and Industrial Mathematics*, 5(2):221–230, 2011.
- [73] R. M. Karp. *Reducibility among Combinatorial Problems*, pages 85–103. Springer US, Boston, MA, 1972.

- [74] S.-J. Kim and B. Park. Counterexamples to the list square coloring conjecture. *Journal of Graph Theory*, 78(4):239–247, 2015.
- [75] S.-J. Kim and B. Park. List 3-dynamic coloring of graphs with small maximum average degree. *Discrete Mathematics*, 341:1406–1418, 2018.
- [76] S.-J. Kim and W.-J. Park. List dynamic coloring of sparse graphs. *Combinatorial Optimization and Applications*, 6831:156–162, 2011.
- [77] K. Knauer, H. La, and P. Valicov. Feedback vertex sets in (directed) graphs of bounded degeneracy or treewidth. arXiv:2111.14986, 2021.
- [78] K. Knauer, P. Valicov, and P. S. Wenger. Planar digraphs without large acyclic sets. *J. Graph Theory*, 85(1):288–291, 2017.
- [79] A. V. Kostochka and D. R. Woodall. Choosability conjectures and multicircuits. *Discrete Mathematics*, 240:123–143, 2001.
- [80] F. Kramer and H. Kramer. Ein Färbungsproblem der Knotenpunkte eines Graphen bezüglich der Distanz  $p$ . *Revue Roumaine de Mathématiques Pures et Appliquées*, 14(2):1031–1038, 1969.
- [81] F. Kramer and H. Kramer. Un problème de coloration des sommets d’un graphe. *Comptes Rendus Mathématique Académie des Sciences, Paris*, 268:46–48, 1969.
- [82] H. La. 2-distance list  $(\Delta + 3)$ -coloring of sparse graphs. arXiv:2105.01684, 2021.
- [83] H. La, B. Lužar, and K. Štorgel. Further extensions of Grötzsch theorem. *Discrete Mathematics*, 345(6):112849, 2022.
- [84] H. La and M. Montassier. 2-distance 4-coloring of planar subcubic graphs with girth at least 21. arXiv:2106.03587, 2021.
- [85] H. La and M. Montassier. 2-distance  $(\Delta + 1)$ -coloring of sparse graphs using the potential method. arXiv:2103.11687, 2021.
- [86] H. La and M. Montassier. 2-distance  $(\Delta + 2)$ -coloring of sparse graphs. arXiv:2109.11927, 2021.
- [87] H. La and M. Montassier. 2-distance list  $(\delta + 2)$ -coloring of planar graphs with girth at least 10. arXiv:2109.14499, 2021.
- [88] H. La, M. Montassier, A. Pinlou, and P. Valicov.  $r$ -hued  $(r + 1)$ -coloring of planar graphs with girth at least 8 for  $r \geq 9$ . *European Journal of Combinatorics*, 91, 2021.
- [89] H. La and K. Štorgel. 2-distance, injective, and exact square list-coloring of planar graphs with maximum degree 4. arXiv, 2022.
- [90] H. La and P. Valicov. Computer assisted discharging procedure on planar graphs: application to 2-distance coloring. arXiv:2202.03885, 2022.
- [91] H.-J. Lai, H. Song, and J.-L. Wu. On  $r$ -hued coloring of planar graphs with girth at least 6. *Discrete Applied Mathematics*, 198:251–263, 2016.
- [92] C. F. Laywine and G. L. Mullen. *Discrete mathematics using Latin squares*, volume 49. Wiley, 1998.

- [93] B. Lidický and F. Pfender. Semidefinite programming and Ramsey numbers. *SIAM J. Discrete Math.*, 35(4):2328–2344, 2021.
- [94] S. Loeb, T. Mahoney, B. Reiniger, and J. Wise. Dynamic coloring parameters for graphs with given genus. *Discrete Applied Mathematics*, 235:129–141, 2018.
- [95] B. Lužar and R. Škrekovski. Counterexamples to a conjecture on injective colorings. *Ars Mathematica Contemporanea*, 8:291–295, 2015.
- [96] B. Lužar, R. Škrekovski, and M. Tancer. Injective colorings of planar graphs with few colors. *Discrete Mathematics*, 309:5636–5649, 9 2009.
- [97] B. D. McKay, M. Miller, and J. Širáň. A note on large graphs of diameter two and given maximum degree. *Journal of Combinatorial Theory, Series B*, 74(1):110–118, 1998.
- [98] B. Montgomery. Ph.d. dissertation. *West Virginia University*, 2001.
- [99] D. Neiman, J. Mackey, and M. Heule. Tighter bounds on directed Ramsey number  $R(7)$ , 2020.
- [100] V. Neumann-Lara. Vertex colourings in digraphs. Some problems. *University of Waterloo*, 1985.
- [101] J. Nešetřil and P. O. de Mendez. *Sparsity — Graphs, Structures, and Algorithms*, volume 28. Springer-Verlag, Berlin, Heidelberg, 2012.
- [102] T. Pierron. A brooks-like result for graph powers. *arXiv:1912.11181*, 2019.
- [103] D. A. Quiroz. Colouring exact distance graphs of chordal graphs. *Discrete Mathematics*, 343(5):111769, 2020.
- [104] N. Robertson, D. Sanders, P. Seymour, and R. Thomas. The four-colour theorem. *Journal of Combinatorial Theory, Series B*, 70(1):2–44, 1997.
- [105] A. Sanchez-Flores. On tournaments and their largest transitive subtournaments. *Graphs Comb.*, 10(4):367–376, 1994.
- [106] A. Sanchez-Flores. On tournaments free of large transitive subtournaments. *Graphs Comb.*, 14(2):181–200, 1998.
- [107] S. K. Simić. Graph equations for line graphs and  $n$ -distance graphs. *Publications de l'Institut de Mathématiques de Beograd*, 33(47):203–216, 1983.
- [108] H. Song, S.-H. Fan, Y. Chen, L. Sun, and H.-J. Lai. On  $r$ -hued coloring of  $K_4$ -minor free graphs. *Discrete Mathematics*, 315-316:47–52, 2014.
- [109] H. Song and H.-J. Lai. Upper bound of  $r$ -hued colorings of planar graphs. *Discrete Applied Mathematics*, 243:262–369, 2018.
- [110] R. Stearns. The voting problem. *Am. Math. Mon.*, 66:761–763, 1959.
- [111] R. Steinberg. The State of the Three Color Problem. In J. Gimbel, J. W. Kennedy, and L. V. Quintas, editors, *Quo Vadis, Graph Theory?*, volume 55 of *Annals of Discrete Mathematics*, pages 211–248. Elsevier, 1993.
- [112] G. Szekeres and Herbert S. Wilf. An inequality for the chromatic number of a graph. *Journal of Combinatorial Theory*, 4(1):1–3, 1968.

- [113] C. Thomassen. Every planar graph is 5-choosable. *Journal of Combinatorial Theory, Series B*, 62(1):180–181, 1994.
- [114] C. Thomassen. The square of a planar cubic graph is 7-colorable. *Journal of Combinatorial Theory, Series B*, 128:192–218, 2018.
- [115] M. Voigt. List colourings of planar graphs. *Discrete Mathematics*, 120(1):215–219, 1993.
- [116] M. Šurimová, B. Lužar, and T. Madaras. Adynamic coloring of graphs. *Discrete Appl. Math.*, 284:224–233, 2020.
- [117] G. Wegner. Graphs with given diameter and a coloring problem. *Technical report, University of Dortmund*, 1977.



# Appendix

In order:

- [5] V. Bartier, L. Bénéteau, M. Bonamy, H. La, and J. Narboni. A note on deterministic zombies. *Discrete Applied Mathematics*, 301:65–68, 2021.
- [77] K. Knauer, H. La, and P. Valicov. Feedback vertex sets in (directed) graphs of bounded degeneracy or treewidth. arXiv:2111.14986, 2021.
- [82] H. La. 2-distance list  $(\Delta + 3)$ -coloring of sparse graphs. arXiv:2105.01684, 2021.
- [83] H. La, B. Lužar, and K. Štorgel. Further extensions of grötzsch theorem. *Discrete Mathematics*, 345(6):112849, 2022.
- [84] H. La and M. Montassier. 2-distance 4-coloring of planar subcubic graphs with girth at least 21. arXiv:2106.03587, 2021.
- [85] H. La and M. Montassier. 2-distance  $(\Delta + 1)$ -coloring of sparse graphs using the potential method. arXiv:2103.11687, 2021.
- [86] H. La and M. Montassier. 2-distance  $(\Delta + 2)$ -coloring of sparse graphs. arXiv:2109.11927, 2021.
- [87] H. La and M. Montassier. 2-distance list  $(\Delta + 2)$ -coloring of planar graphs with girth at least 10. arXiv:2109.14499, 2021.
- [88] H. La, M. Montassier, A. Pinlou, and P. Valicov.  $r$ -hued  $(r + 1)$ -coloring of planar graphs with girth at least 8 for  $r \geq 9$ . *European Journal of Combinatorics*, 91, 2021.
- [89] H. La and K. Štorgel. 2-distance, injective, and exact square list-coloring of planar graphs with maximum degree 4. arXiv, 2022.
- [90] H. La and P. Valicov. Computer assisted discharging procedure on planar graphs: application to 2-distance coloring. arXiv:2202.03885, 2022.