



**HAL**  
open science

# Geometric challenges in combinatorial optimization : packing, hitting, and coloring rectangles

Marco Caoduro

► **To cite this version:**

Marco Caoduro. Geometric challenges in combinatorial optimization : packing, hitting, and coloring rectangles. Combinatorics [math.CO]. Université Grenoble Alpes [2020-..], 2022. English. NNT : 2022GRALM028 . tel-04076241

**HAL Id: tel-04076241**

**<https://theses.hal.science/tel-04076241v1>**

Submitted on 20 Apr 2023

**HAL** is a multi-disciplinary open access archive for the deposit and dissemination of scientific research documents, whether they are published or not. The documents may come from teaching and research institutions in France or abroad, or from public or private research centers.

L'archive ouverte pluridisciplinaire **HAL**, est destinée au dépôt et à la diffusion de documents scientifiques de niveau recherche, publiés ou non, émanant des établissements d'enseignement et de recherche français ou étrangers, des laboratoires publics ou privés.

THÈSE

Pour obtenir le grade de

**DOCTEUR DE L'UNIVERSITÉ GRENOBLE ALPES**

École doctorale : MSTII - Mathématiques, Sciences et technologies de l'information, Informatique

Spécialité : Mathématiques et Informatique

Unité de recherche : Laboratoire des Sciences pour la Conception, l'Optimisation et la Production de Grenoble

**Problèmes de géométrie en optimisation combinatoire : packing, transversaux, et coloration de rectangles**

**Geometric challenges in combinatorial optimization: packing, hitting, and coloring rectangles**

Présentée par :

**Marco CAODURO**

Direction de thèse :

**Andras SEBO**

Directeur de thèse

**Matej STEHLIK**  
Professeur, UGA

Co-directeur de thèse

Rapporteurs :

**BARTOSZ WALCZAK**

Professeur associé, Uniwersytet Jagielloński w Krakowie

**DANIEL GONÇALVES**

Chargé de recherche HDR, CNRS DELEGATION OCCITANIE EST

Thèse soutenue publiquement le **8 novembre 2022**, devant le jury composé de :

**ZOLTAN SZIGETI**

Professeur des Universités, GRENOBLE INP

Président

**BARTOSZ WALCZAK**

Professeur associé, Uniwersytet Jagielloński w Krakowie

Rapporteur

**DANIEL GONÇALVES**

Chargé de recherche HDR, CNRS DELEGATION OCCITANIE EST

Rapporteur

**ANDREAS WIESE**

Professeur associé, Technische Universität München

Examineur

**LOUIS ESPERET**

Directeur de recherche, CNRS DELEGATION ALPES

Examineur

**MARTHE BONAMY**

Chargé de recherche, CNRS DELEGATION AQUITAINE

Examinatrice

**VICTOR CHEPOI**

Professeur des Universités, AIX-MARSEILLE UNIVERSITE

Examineur

Invités :

**ANDRAS SEBŐ**

Directeur de recherche émérite, CNRS DELEGATION ALPES

**MATEJ STEHLIK**

Professeur des Universités, UNIVERSITE DE PARIS-CITE





# Acknowledgments

Thinking back on the years I spent in Grenoble preparing my doctoral dissertation, there are so many people I would like to thank that it is difficult for me even to know where to begin.

Let's start with the two people without whom this thesis would not have even begun: my advisors, András Sebő and Matěj Stehlík. András, I am sincerely grateful for all the time you dedicated to me during these three years. Your passion for mathematics has been highly contagious. Thank you for the countless corrections and the help you offered me while writing this manuscript. It is an honor to be your last (official) student! Matěj, thank you for your energy, understanding, and help throughout my project. Thank you for supporting me during the supervision of Thomas Boudier and for putting me in touch with Lyuben Lichev. Both collaborations have had a significant impact on my development. Also, it was a pleasure to be your guest at IRIF.

A big thank you goes to the jury: to the jury chair, Zoltan (Zoli) Szigeti; to the examiners Marthe Bonamy, Andreas (Andy) Wiese, Louis Esperet, and Victor Chepoi; and especially to the two referees, Bartosz Walczak and Daniel Gonçalves. Your comments and questions have enabled me to further improve the content and presentation of the manuscript.

I would also like to thank all the members of my laboratory for creating a stimulating and supportive environment in which to conduct my research. Particularly, Fadila, Marie Jo, and Sarah for helping me solve bureaucratic problems; my officemates (and friends): Emilio, Akash, Ernest, and Camille; my tutor (and chess mentor) Florian; and Alexandre and Cléopée for many pleasant afternoons thinking about graph problems.

My heartfelt thanks to my friends! A complete list would be too long, but I cannot fail to mention *Les Dents* or *Bellu*, Ludo, Marti, and Calum; Thomas (aka *Il Presidente*); and Pietro and Marta for helping me get through the difficult months of the pandemic.

Last but far from least, my better half, Marie; my parents, Marina and Mario; and all my family. Without them, this achievement would not have been possible.



# Contents

<b>Abstract</b>	<b>11</b>
<b>Résumé</b>	<b>13</b>
<b>Introduction</b>	<b>15</b>
0.1 Warm-up . . . . .	16
0.2 Geometric objects . . . . .	18
0.3 Notions of Graph Theory . . . . .	20
0.4 Complexity . . . . .	21
0.5 Problems . . . . .	22
0.5.1 Two useful techniques . . . . .	23
0.5.2 Intervals in a line . . . . .	24
0.5.3 Segments in the plane . . . . .	25
<b>1 Axis-parallel rectangles</b>	<b>27</b>
1.1 Coloring rectangles . . . . .	29
1.1.1 Triangle-free families . . . . .	31
1.1.2 Rectangles with a bounded aspect ratio . . . . .	34
1.2 Hitting rectangles . . . . .	35
1.2.1 Cross-free rectangles . . . . .	39
1.2.2 Rectangles with a bounded aspect ratio . . . . .	43
1.2.3 Extra bounds on $\tau$ . . . . .	44
<b>2 Axis-parallel segments</b>	<b>47</b>
2.1 Introduction . . . . .	48
2.2 Lower bound . . . . .	50
2.3 Extreme examples . . . . .	54
2.4 Upper bound on the hitting number . . . . .	56
<b>3 Squares and rectangles</b>	<b>59</b>
3.1 Introduction . . . . .	60
3.2 Relating hitting and covering . . . . .	62
3.2.1 The relation . . . . .	63
3.2.2 General brute force framework . . . . .	64
3.3 Filling holes . . . . .	67
3.3.1 Filling holes inside triangles . . . . .	67
3.3.2 Filling holes outside separating lines . . . . .	68

3.3.3	Patch using the triangle inequality . . . . .	69
3.4	Deducing the new bounds for squares . . . . .	69
3.4.1	Completing the tools . . . . .	70
3.4.2	Hitting Squares . . . . .	71
3.4.3	Coloring squares . . . . .	78
3.5	Rectangles . . . . .	79
3.5.1	Hitting dancing rectangles . . . . .	79
3.5.2	Coloring rectangles . . . . .	81
3.6	Conclusion and open questions . . . . .	83
<b>4</b>	<b>Boxicity of popular graphs and Kneser graphs</b>	<b>85</b>
4.1	Introduction . . . . .	87
4.2	Properties of co-rectangle graphs . . . . .	89
4.2.1	Direct applications . . . . .	91
4.3	Boxicity of the Ramsey graph $G_{3,5}$ and the Grötzsch graph . . . . .	92
4.3.1	The Ramsey graph $G_{3,5}$ . . . . .	92
4.3.2	The Grötzsch graph . . . . .	94
4.4	Boxicity of the Kneser graph $K(n, 2)$ . . . . .	96
	<b>Conclusion</b>	<b>107</b>
	<b>Bibliography</b>	<b>114</b>

# List of Figures

1	Map of Grenoble with neighborhoods modeled by disks (background image from Google Maps). . . . .	16
2	Map of Grenoble with antennas transmitting in the neighborhoods. The different colors of the disks represent different frequencies (background image from Google Maps). . . . .	18
3	Five disks forming a cycle. The red disks are a packing, and the black points are a hitting set. . . . .	19
4	Five disks forming a cycle and a proper 3-coloring of them. . . . .	19
5	Three pairwise intersecting squares with an empty intersection. . . . .	20
6	Two different drawings of the same graph. . . . .	20
7	A family of $n$ segments with $\Delta = 2$ , $\chi = n$ , and $\nu = 1$ , $\tau = \lceil n/2 \rceil$ . It can be constructed by taking $n$ lines in general position and considering the intersection between them and a large disk containing all the intersection points. . . . .	25
1.1	Different types of intersection between axis-parallel rectangles. . . . .	30
1.2	A family of convex sets with the underlying planar graph. . . . .	33
1.3	Definition of the hitting set $P$ . . . . .	34
1.4	Illustration of the lines used in Proposition 1.19. . . . .	36
1.5	Four axis-parallel rectangles forming a cycle. . . . .	38
1.6	Representation of the family $\mathcal{J}_4$ . . . . .	38
1.7	From left to right $R$ is: pendant, a horizontal-bridge from $M$ to $M'$ , and a vertical-bridge from $M$ to $M'$ . . . . .	40
1.8	Representation of some rectangles in $\mathcal{M}$ (fat borders) and horizontal-bridges (gray rectangles), and the corresponding subgraph of $G$ . . . . .	42
1.9	On the left, the light gray rectangles represent a packing, and the other rectangles are a set of bridges. On the right, the graph obtained following the construction in the proof of Theorem 1.25 . . . . .	43
2.1	Selection of the two pairwise disjoint families in the proof of Lemma 2.9. Crosses are the meeting points, disks are the candidate points, and gray disks are the cut points. The black dotted line is the cut. Dashed blue and solid orange segments are those chosen for the families $\mathcal{S}_{\text{blue}}$ and $\mathcal{S}_{\text{orange}}$ , respectively. . . . .	53
2.2	A 6-box. Crosses represent the meeting points. Every line contains two segments of the box intersecting only the meeting point on the line. . . . .	54
2.3	The family $\mathcal{M}_3$ . Crosses represent the meeting points. The dashed lines indicate the sides of the large square and the $k$ -boxes. . . . .	55



3.1	An axis-parallel square and the domain of the centers of its neighbors. . .	64
3.2	A “hole” not covered by any of three disks, but “patched”: the three vertices of the triangle hit all unit squares having their center in the dark hole. . .	65
3.3	The outer and inner squares of two intersecting convex sets with slimness $\rho_\infty \leq \rho$ and inner unit squares. In red, the inner square of $F_0$ and in blue, the one of $F$ . . . . .	67
3.4	A feasible input for Lemma 3.12 . . . . .	69
3.5	Figure (a) illustrates the setup of Lemma 3.13, while Figure (b) shows the additional “patch” that is obtained. . . . .	70
3.6	The two kinds of crossing intersections. . . . .	71
3.7	A unit square and the 10 points hitting its neighbors. . . . .	72
3.8	(a) The half-disk $Q$ , the “strip” $Q_t$ , and the disk $B_2(O, \frac{\sqrt{2}}{2})$ swept by all possible $C$ . (b) The planned 6 hitting points with the disks of all centers of unit squares they surely hit. . . . .	73
3.9	Representation of the sets $C_1$ and $C_2$ . . . . .	74
3.10	Representation of the center of a square that is not hit by any point in $H_1$ . . . . .	76
3.11	Transformation of the squares in $N[S] - S$ . . . . .	77
3.12	Pairwise intersecting squares with $\nu = 1$ , and $\tau = 2$ (a), $\tau = 3$ (b), (c). . . . .	77
3.13	13 pairwise intersecting squares with $\nu = 1$ , and $\tau = 4$ . . . . .	78
3.14	Definition of the distance $d$ . . . . .	80
3.15	Hitting points of the neighbors of $R$ . . . . .	81
3.16	Points in $R$ . . . . .	82
3.17	Crossing rectangles $R, R'$ , where $R'$ does not intersect the middle segment of $R$ . . . . .	82
3.18	Some possible intersections between $s$ and $R'$ . . . . .	83
3.19	Unit square with seven pairwise disjoint neighbors. . . . .	84
4.1	Family of circular arcs having $\overline{3K_2}$ as intersection graph. . . . .	92
4.2	$G_{3,5}$ where the vertices of the defining circuit $Q$ are labelled consecutively from $v_1$ to $v_{13}$ (left); a family of axis-parallel rectangles realizing the intersection graph of $G_{3,5} - \{v_1, v_7\}$ (right). . . . .	93
4.3	Grötzsch graph $M(C_5)$ , where the vertices of $C_5$ are $v_1, \dots, v_5$ , and then the notation follows the Mycielski construction (left); a family of axis-parallel rectangles realizing the intersection graph of $M(C_5) - v_0$ (right). . . . .	95
4.4	The continuous black lines are edges of the Grötzsch graph that play a role for the three induced 5-cycle with a common edge $v_3v_4$ in the proof. The dotted lines represent red edges and the dash-dotted ones blue edges. The contradiction appears when it comes to color edge $v'_2v'_5$ . . . . .	95
4.5	A triangle-free family of 15 axis-parallel rectangles with chromatic number 4. . . . .	96
4.6	(left) $K_5$ , the complete graph on five vertices, (right) $\overline{L(K_5)}$ , the Petersen graph. The correspondences between the edges of $K_5$ and the vertices of $\overline{L(K_5)}$ are remarked in the labels of the drawing on the right. . . . .	97
4.7	The edges of $V(K_n)$ that can be contained in $\sigma$ in Case 1. The edges with fat lines are the ones corresponding to $v_1, v_2, v_3$ , and the ones with dashed red lines correspond to the vertices in $N^+(v_3)$ . . . . .	100

- 4.8 The edges of  $V(K_n)$  that can be contained in  $\sigma$  in Case 2. The edges with fat lines are the ones corresponding to  $v_1, v_2, v_3$ , and the ones with dashed red lines correspond to the vertices in  $N^+(v_3)$ . . . . . 101
- 4.9 The edges of  $V(K_n)$  that can be contained in  $\sigma$  in Case 3. The edges with fat lines are the ones corresponding to  $v_1$  and  $v_2$ , and the ones with dashed red lines correspond to the vertices in  $N^+(v_2)$ . . . . . 102



# Abstract

Geometric intersection graphs are graphs arising from families of geometric objects in the plane (and, more generally, in  $\mathbb{R}^d$ ). This class has captured the attention of many researchers because it is rich in theoretical issues and practical applications. In this manuscript, we restrict our attention to the combinatorial properties of rectangles, segments, and squares in the plane, axis-parallel or not. Many fundamental questions about these objects arose in the '60s. These works focused on the relation between the *hitting number* (minimum number of points necessary to hit all the objects in the family) and the *packing number* (maximum number of pairwise disjoint objects), and between the *chromatic number* (minimum number of colors such that all pairs of intersecting objects have distinct colors) and the *clique number* (maximum number of pairwise intersecting objects).

The first part of the thesis deals with Wegner's conjecture. This conjecture, proposed by Gerd Wegner in 1965, states that *for every family of axis-parallel rectangles in the plane, the hitting number of the family is smaller than twice its packing number*. We present the state of the art on this problem with several partial results, mainly focusing on particular cases, such as families with a triangle-free intersection graph and families with no crossing rectangles. Similarly, we also explore the problem of bounding the chromatic number in terms of the clique number. Then, we deal with the particular case of axis-parallel segments. We prove that not only the multiplicative constant in Wegner's conjecture is *valid* for this degenerate class of rectangles, but, surprisingly, it is also *tight*.

In the second part of the manuscript, we drop the axis-parallel assumption and study the combinatorial properties of rectangles that are not necessarily parallel to the axes. When the rectangles are also allowed to rotate, neither the hitting number nor the chromatic number can be bounded by the packing number or the clique number, respectively. For this reason, we restrict our attention to squares and rectangles with a *bounded aspect ratio*, where the aspect ratio of a rectangle is the ratio between its longer and shorter sides. The ratio between hitting and packing numbers and chromatic and clique numbers are wide open for natural objects such as disks and squares. For squares, we decrease these gaps by establishing linear bounds with reasonably small constants. Moreover, we generalize these results for rectangles with a bounded aspect ratio.

These questions lead to the subject of the *boxicity* of a graph, that is, the minimum dimension  $d$  such that the graph is the intersection graph of a family of axis-aligned boxes in  $\mathbb{R}^d$ . This parameter, introduced by Roberts in 1969, is well-studied for several graph classes, such as planar graphs, chordal graphs, and line graphs. In the third and final part of the thesis, we develop techniques to compute the boxicity of a graph based on the forbidden induced subgraphs of interval graphs and specific properties of interval orders. These techniques aim to explore the class of graphs having parameters of interest for the hitting and coloring conjectures discussed in the first part. Doing this, we prove that various of the

most popular graphs in *Graph Theory*, such as the Grötzsch graph, the Chvátal graph, the Petersen graph, and two of the smallest Ramsey graphs, are not the intersection graphs of axis-parallel rectangles in the plane, while they can be represented by axis-aligned boxes in  $\mathbb{R}^3$ . Our method also extends to higher dimensions and allows us to compute exactly the boxicity of the complement of the line graph of  $K_n$  for  $n \geq 5$  (that corresponds to the Kneser graph  $K(n, 2)$ ).

# Résumé

Les graphes d'intersection géométriques sont des graphes qui proviennent de familles d'objets géométriques dans le plan (et, plus généralement, dans  $\mathbb{R}^d$ ). Cette classe a attiré l'attention de nombreux chercheurs car elle est riche en questions théoriques et en applications pratiques. Dans ce manuscrit, nous nous limitons aux propriétés combinatoires des rectangles, segments et carrés dans le plan, parallèles aux axes ou non. De nombreuses questions fondamentales sur ces objets ont été soulevées dans les années 60. Ces travaux se sont concentrés sur la relation entre le *nombre transversal* (nombre minimum de points nécessaires pour intersecter tous les objets de la famille) et le *nombre de packing* (nombre maximum d'objets disjoint 2 à 2), ainsi qu'entre le *nombre chromatique* (nombre minimum de couleurs telles que toutes paires d'objets s'intersectant ont des couleurs distinctes) et le *nombre de clique* (nombre maximum d'objets que s'intersectant 2 à 2).

La première partie de la thèse traite de la célèbre conjecture de Wegner. Cette conjecture, proposée par Gerd Wegner en 1965, stipule que *pour toute famille de rectangles parallèles aux axes dans le plan, le nombre transversal de la famille est au plus deux fois son nombre de packing moins un*. Nous présentons l'état de l'art sur ce problème avec plusieurs résultats partiels, en nous concentrant principalement sur des cas particuliers, tels que les familles avec un graphe d'intersection sans triangle et les familles sans rectangles croisés. De même, nous explorons le problème de la borne du nombre chromatique en fonction du nombre de clique. Ensuite, nous traitons le cas particulier des segments parallèles aux axes. Nous prouvons que non seulement la constante de la conjecture de Wegner est *valide* pour cette classe dégénérée de rectangles, mais, qu'étonnamment, elle est aussi *optimale*.

Dans la deuxième partie du manuscrit, nous abandonnons l'hypothèse de parallélisme des axes et étudions les propriétés combinatoires des rectangles qui ne vérifient pas nécessairement cette propriété. Lorsque la rotation des rectangles est également autorisée, ni le nombre transversal ni le nombre chromatique ne peuvent être bornés respectivement par le nombre de packing ou le nombre de clique. Pour cette raison, nous portons notre attention sur les carrés et les rectangles dont le rapport de forme, c'est-à-dire le rapport entre la longueur de ses côtés les plus longs et les plus courts, est borné. Le rapport entre les nombres transversal et de packing ainsi que celui entre les nombres chromatique et de clique sont également des questions ouvertes pour les objets naturels tels que les disques et les carrés. Nous réduisons ces écarts en établissant des bornes linéaires avec des constantes raisonnablement petites pour les carrés et en généralisant ces résultats pour les rectangles dont le rapport de forme est borné.

Ces questions nous amènent à nous interroger sur la *boxicité* d'un graphe, c'est-à-dire la dimension minimale  $d$  telle que le graphe soit le graphe d'intersection d'une famille de boîtes alignées sur l'axe dans  $\mathbb{R}^d$ . Ce paramètre, introduit par Roberts en 1969, est bien étudié dans plusieurs classes de graphes, comme les graphes planaires, les graphes triangulés

et les line graphs. Dans la troisième et dernière partie de la thèse, nous développons des techniques pour calculer la boxicité d'un graphe en se basant sur les sous-graphes induits interdits des graphes d'intervalles et sur des propriétés spécifiques des ordres d'intervalles. Ces techniques visent à explorer la classe des graphes ayant des paramètres d'intérêt pour les conjectures de transversal et de coloration discutées dans la première partie. Ainsi, nous prouvons que certains des graphes parmi les plus célèbres en *Théorie des graphes*, tels que le graphe de Grötzsch, le graphe de Chvátal, le graphe de Petersen, et certains des plus petits graphes de Ramsey, ne sont pas des graphes d'intersection de rectangles parallèles aux axes dans le plan, alors qu'ils peuvent être représentés par des boîtes parallèles aux axes dans  $\mathbb{R}^3$ . Notre méthode s'étend également aux dimensions supérieures et nous permet de calculer exactement la boxicité du complément du line graph de  $K_n$  pour  $n \geq 5$  (ce qui correspond au graphe de Kneser  $K(n, 2)$ ).

# Introduction

In this chapter, we give a gentle introduction to the problems of packing, hitting, and coloring geometric objects and the notation used in this work. In Section 0.1, we describe three real-life problems that serve as warm-up and, in Section 0.2, we give the formal definition of hitting, packing, and coloring. Although our work is not directly motivated by practical purposes, making a connection between theoretical problems and practical examples helps to understand and to make sense of the optimization problems we will address later. In Section 0.3, we recall definitions and useful results from *Graph Theory* and discuss the relationship between a family of sets and its corresponding intersection graph. In Section 0.4, we review concepts of *Complexity Theory*. Finally, in Section 0.5, we explicitly state the research problems we study in the following chapters. Moreover, we detail the degeneracy argument that often occurs in this thesis and we give two similarly looking examples with different behaviors: intervals in a line and segments in the plane.



## 0.1 Warm-up

We live and move in a world made up of objects: the desks we work on, the shelves where we rearrange our books, and the containers we use to ship goods around the world. Relating to geometric objects, we are often confronted with optimization problems. As a warm-up, we present some samples.

A comprehensive set of problems that can be modeled using points and intervals is given in Golumbic [44]. We detail here one of them.

### *Scheduling lectures*

**Input:** Time intervals of university lectures that are scheduled on a given day.

**Output:** The minimum number of classrooms needed to allocate all lectures to a classroom, avoiding two lectures with a time intersection being assigned to the same classroom.

**Model:** An optimal solution is a minimum coloring of the intervals such that two intersecting intervals receive a different color. The minimum size of the coloring equals the minimum number of classrooms needed.

Shifting from one to two dimensions, the range of different scenarios that can be modeled using geometric objects increases considerably. In the following, we give three applications that can be presented in a similar setting. Consider a metropolitan city structured in neighborhoods. For simplicity, assume that every neighborhood has a center (for example, the point that has the minimal maximal distance from the buildings in the neighborhood), and approximate the area with a geometric shape, such as a disk or a polygon (see Figure 1).

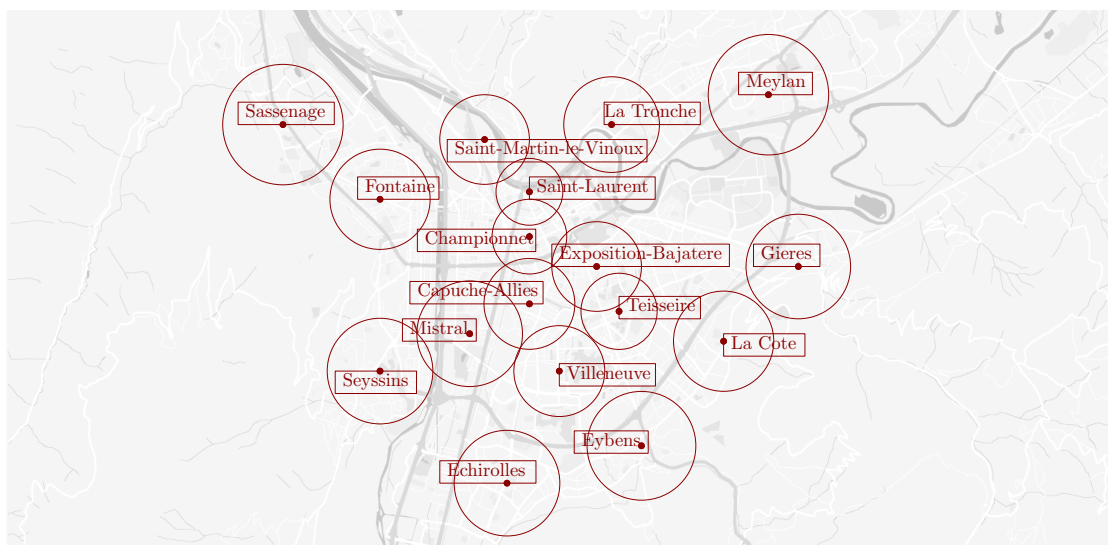

Figure 1: Map of Grenoble with neighborhoods modeled by disks (background image from Google Maps).

### *Map labeling problem [1]*

**Input:** A map of a city and a set of labels to display. Each label contains the name of a neighborhood.

**Output:** An arrangement of the labels such that the number of displayed labels is maximized, each displayed label contains the center of the neighborhood it represents, and, for readability, no two labels intersect.

**Model:** Represent the centers of the neighborhoods as points in the plane. Define a set of possible labels considering for each center all possible arrangements of an axis-parallel rectangle that contains it (the height is fixed and the width depends on the length of the name of that neighborhood). An optimal solution to the problem is a maximum set of pairwise disjoint rectangles (see Figure 1). Notice that two rectangles representing the same label intersect in the center of their neighborhood, so both cannot be in the same solution.

The second problem deals with allocating antennas to provide access to a new kind of signal (e.g. 5G). We assume that antennas are powerful enough to provide connection to a neighborhood if they are contained in it (or, more precisely, in the geometric object that approximates it) but not powerful enough to cover a nearby area that does not include it.

*Resource allocation problem [88]*

**Input:** A map of a city structured in neighborhoods.

**Output:** A minimum size arrangement of antennas such that each neighborhood can access the signal from at least one antenna.

**Model:** Represent in the plane the geometric objects approximating the neighborhoods. An optimal solution to the problem is a minimum set of points that hit the objects, that is, every object contains at least one point.

The same problem could also be modeled as a *covering* problem: assume that each antenna can provide a connection to the points at distance at most  $d \in \mathbb{R}$  kilometers from it. Then, a solution is a set of disks of radius  $d$  covering all the centers of the neighborhoods (see Figure 2). In practice, it can be realized by placing an antenna in the center of each of the disks in a solution. The connection between hitting and covering will be further developed in Section 3.2.

Once the antennas are placed, we aim to reduce interference and limit the use of the frequency spectrum. In our model, two antennas cause mutual interference if they use the same frequency and are close to each other (that is, at a distance smaller than  $2d$  kilometers).

*Bandwidth allocation problem [52]*

**Input:** A map of a city and an arrangement of antennas.

**Output:** An assignment of frequencies to the antennas so that two antennas with mutual interference receive different frequencies and the number of used frequencies is minimized.

**Model:** Represent each antenna with a disk of radius  $d$  centered in the position of the antennas. An optimal solution to the problem is a coloring of the disks in such a way that two intersecting disks receive different colors. Assigning the same frequency to the antennas with the same color result in a solution to the allocation problem (see Figure 2).

## Certificates

The resource and bandwidth allocation problems have a property in common: both these problems have dual parameters that give a lower bound on the size of an optimal solution. If there are  $n$  neighborhoods with pairwise disjoint reception areas, then at least  $n$  antennas are necessary since each of these neighborhoods needs a different one. Similarly, if there

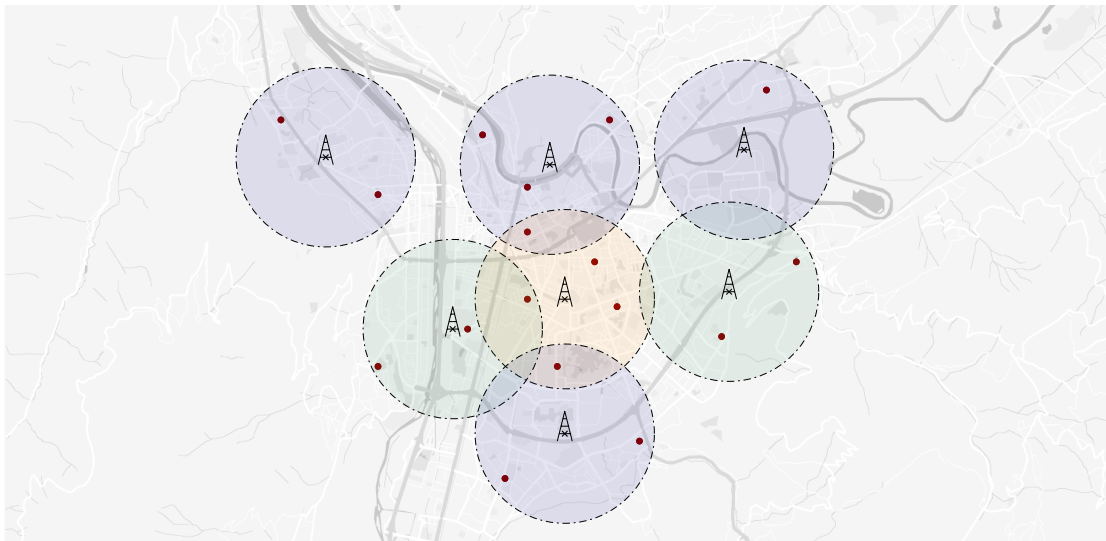

Figure 2: Map of Grenoble with antennas transmitting in the neighborhoods. The different colors of the disks represent different frequencies (background image from Google Maps).

are  $m$  antennas that can transmit at the same point, then any of these antennas has to have a different frequency, so at least  $m$  different frequencies are needed.

Two questions naturally arise: *is there a solution that matches this necessary condition? And if not, how far can an optimal solution be from this first approximation?* For example, if among the antennas there are ten with pairwise mutual interference, and there are no assignments of ten frequencies that meet our needs, should we expect to have a solution with eleven frequencies, twenty frequencies, or could it even be possible that a hundred, or more, frequencies are needed? This kind of question lies at the heart of our work.

## 0.2 Geometric objects

The three problems we previously presented are about finding or estimating parameters of a configuration of objects in the plane, while the final part of Section 0.1 addressed the relations between these parameters. In this section, we state formal definitions allowing us to model and generalize the discussed topics.

The definitions of the main parameters for geometric objects (disks, squares, convex sets, etc.) in the plane can be stated more generally for families of sets.

Let  $\mathcal{F}$  be a finite family of sets on a common set of elements (that may be infinite). A *packing* in  $\mathcal{F}$  is a subfamily of pairwise disjoint sets in  $\mathcal{F}$ . The *packing number* of  $\mathcal{F}$ , denoted by  $\nu(\mathcal{F})$ , is the maximum size of a packing. A *hitting set* is a set of points with a non-empty intersection with each set in  $\mathcal{F}$ . The *hitting number* of  $\mathcal{F}$ , denoted by  $\tau(\mathcal{F})$ , is the minimum size of a hitting set. For any family  $\mathcal{F}$  of sets,  $\tau(\mathcal{F}) \geq \nu(\mathcal{F})$  because an element cannot hit two disjoint sets. Equality does not generally hold: Figure 3 shows a family of five disks with packing number  $\nu = 2$  and hitting number  $\tau = 3$ .

Going back to Section 0.1, in the map labeling problem, we ask for the packing number of the family of axis-parallel rectangles used in the model, while in the resource allocation problem for a minimum hitting set of the geometric objects used to model the neighbor-

hood.

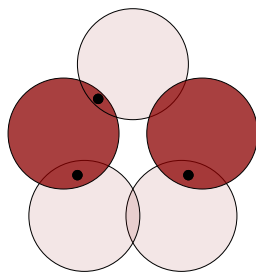

Figure 3: Five disks forming a cycle. The red disks are a packing, and the black points are a hitting set.

A *coloring* of  $\mathcal{F}$  is an assignment of colors to the sets of  $\mathcal{F}$  with the property that intersecting sets receive different colors, or equivalently, a coloring is a partition of  $\mathcal{F}$  into packings. The *chromatic number* of  $\mathcal{F}$ , denoted by  $\chi(\mathcal{F})$ , is the minimum number of colors that can be used to obtain a coloring of  $\mathcal{F}$ . A *clique* of  $\mathcal{F}$  is a subfamily of pairwise intersecting sets in  $\mathcal{F}$ . The *clique number* of  $\mathcal{F}$ , denoted by  $\omega(\mathcal{F})$ , is the maximum size of a clique of  $\mathcal{F}$ . As for the hitting number and the packing number, the chromatic number and the clique number are linked by a direct relation. For any family  $\mathcal{F}$  of sets,  $\chi(\mathcal{F}) \geq \omega(\mathcal{F})$  because any two intersecting sets need distinct colors. A family  $\mathcal{F}$  of five disks forming a cycle has a clique number of two, but it cannot be colored with two colors. Hence,  $\chi(\mathcal{F}) \neq \omega(\mathcal{F})$  (see Figure 4).

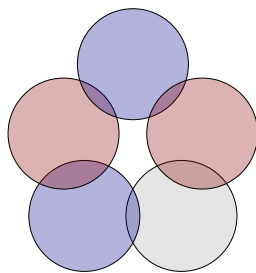

Figure 4: Five disks forming a cycle and a proper 3-coloring of them.

The *maximum degree* of  $\mathcal{F}$ , denoted by  $\Delta(\mathcal{F})$ , is the maximum number of sets in  $\mathcal{F}$  that contain a common element. Since any set of objects containing all a common element are pairwise intersecting,  $\omega(\mathcal{F}) \geq \Delta(\mathcal{F})$ . We say that  $\mathcal{F}$  has the *Helly property* if any subfamily of pairwise intersecting sets in  $\mathcal{F}$  contains a common element. Clearly, if  $\mathcal{F}$  has the Helly property, then  $\Delta(\mathcal{F}) = \omega(\mathcal{F})$ . Not all families of geometric objects have the Helly property, Figure 5 shows three pairwise intersecting squares with an empty intersection.

We introduce more useful definitions. Given a convex object  $A \subset \mathbb{R}^2$ , we denote by  $p_1(A)$  and  $p_2(A)$  its projection on the horizontal and vertical axes, respectively. We can then compare two objects by comparing their projections. For a pair of convex objects  $A, B \subset \mathbb{R}^2$ ,  $A \prec_1 B$  if  $p_1(A)$  is completely to the left of  $p_1(B)$ . Similarly,  $A \prec_2 B$  if  $p_2(A)$  is completely below  $p_2(B)$ . Given a family of convex objects, the two pairs  $(\mathcal{F}, \prec_1)$  and  $(\mathcal{F}, \prec_2)$  are particular types of partially order sets (or posets) called *interval orders*. Interval orders can be characterized in several ways. We report a characterization that outlines the

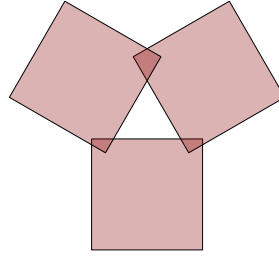

Figure 5: Three pairwise intersecting squares with an empty intersection.

particularity of interval orders. Let  $\mathcal{S}_2$  denote the four element poset  $(\{a_1, b_1, a_2, b_2\}, \prec)$  with relations  $a_1 \prec b_1, a_2 \prec b_2$ .

**Theorem 0.1** (Fishburn , 1970 [37]). *A poset  $\mathcal{P}$  is an interval order if and only if  $\mathcal{P}$  does not contain  $\mathcal{S}_2$  as a subposet.*

### 0.3 Notions of Graph Theory

In this section, we introduce essential definitions that we use in this manuscript. We refer the reader to [30] for further definitions and details.

A (simple) *graph*  $G$  can be defined as a pair  $(V(G), E(G))$  of two sets with  $E(G) \subseteq \binom{V(G)}{2} := \{\{u, v\} : u, v \in V(G) \text{ and } u \neq v\}$ . The first set is called *vertex set* and the second one *edge set*. The cardinality of  $V(G)$  is the *order* of  $G$ , while the one of  $E(G)$  is the *size* of  $G$ . For simplicity, we denote an edge  $\{u, v\}$  with  $uv$ . Informally, a graph can be represented as a set of points in the plane linked by curves. The points represent the vertex set, and two points  $u, v$  are joined by a curve if  $uv$  is an edge. It is important not to confuse the graph with its representation since the same graph can be drawn in several different ways (see Figure 6).

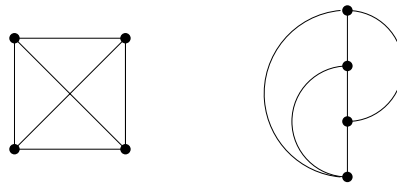

Figure 6: Two different drawings of the same graph.

Given a graph  $G = (V, E)$ , two vertices  $u, v \in V$  are *adjacent* if  $uv$  is an edge of  $G$ . A vertex  $u$  is *incident* to an edge  $e$  if  $u \in e$  and two edges  $e, e'$  are *incident* if they have a common vertex. The set of *neighbors* of a vertex  $u$ , denoted by  $N(u)$ , is  $\{v \in V(G) : uv \in E(G)\}$  and  $N[u]$  is the set  $N(u) \cup \{u\}$ . The set of edges incident to a vertex  $u$  is denoted by  $\delta(u)$ . The *degree* of  $u$ , denoted by  $d(u)$ , is  $|N(u)| = |\delta(u)|$ . By  $\Delta_{\min}(G)$  and  $\Delta_{\max}(G)$  we denote the minimum and maximum degree of a graph  $G$ , respectively.

A *subgraph* of  $G$  is a graph  $H$  with vertex set  $V(H) \subseteq V(G)$  and edge set  $E(H) \subseteq E(G)$ . A subgraph  $H$  is *spanning* if  $V(H) = V(G)$ , and *induced* if for every edge  $uv \in E(G)$ ,  $uv \in E(H)$  if and only if  $\{u, v\} \subseteq V(H)$ . For  $V' \subseteq V(G)$ , we denote by  $G[V']$  the induced subgraph of  $G$  having  $V'$  as vertex set and by  $G - V'$  the subgraph  $G[V \setminus V']$ .

A *stable set*, or *independent set*, in  $G$  is a set of pairwise non-adjacent vertices in  $V(G)$  and the *stability number*, denoted by  $\alpha(G)$ , is the size of a maximum stable set. A *clique* in  $G$  is a set of pairwise adjacent vertices in  $V(G)$  and the *clique covering number*, denoted by  $\theta(G)$ , is the minimum number of cliques needed to partition  $V(G)$ . A (proper) *coloring* of  $G$  is an assignment of colors to the vertices of  $G$  with the property that adjacent vertices receive different colors. The *chromatic number* of  $G$ , denoted by  $\chi(G)$ , is the minimum number of colors used by a coloring of  $G$ . Finally, the *clique number* of  $G$ , denoted by  $\omega(G)$ , is the maximum size of a clique in  $G$ .

These definitions look similar to the ones in Section 0.2. This similarity can be formalized by using the concept of intersection graph. Given a family  $\mathcal{F}$  of sets, the *intersection graph* of  $\mathcal{F}$ , denoted by  $G(\mathcal{F})$ , is the graph having  $\mathcal{F}$  as vertex set and an edge between two vertices if the corresponding sets intersect.

**Lemma 0.2.** *Let  $\mathcal{F}$  be a family of sets and  $G$  its corresponding intersection graph. Then,*

1.  $\chi(\mathcal{F}) = \chi(G)$
2.  $\omega(\mathcal{F}) = \omega(G)$
3.  $\nu(\mathcal{F}) = \alpha(G)$
4.  $\tau(\mathcal{F}) \geq \theta(G)$ , equality holds if  $\mathcal{F}$  has the Helly property.

□

Now, we present a short collection of graph properties and relevant graphs. Consider a graph  $G$ :  $G$  is *bipartite* if  $V(G)$  can be partitioned in two stable sets,  $G$  is *planar* if it can be drawn in the plane so that the curves representing its edges meet only at the vertices' points. The *complement graph* of  $G$ , denoted by  $\overline{G}$ , is the graph having  $V(G)$  as vertex set and  $\{uv : u, v \in V(G) \text{ and } uv \notin E(G)\}$  as edge set. Clearly,  $\chi(G) = \theta(\overline{G})$  and  $\omega(G) = \alpha(\overline{G})$ . The *line graph* of  $G$ , denoted by  $L(G)$ , is the graph having  $E(G)$  as vertex set and an edge between  $x, y \in E(G)$  if  $x$  and  $y$  are incidents in  $G$  (it is the intersection graph of  $E(G)$ ).

The *complete graph* of order  $n$ , denoted by  $K_n$ , is a graph having a vertex set  $V(K_n)$  of size  $n$  and edge set  $E(K_n) = \binom{V(K_n)}{2}$ . Figure 6 shows two different drawings of the graph  $K_4$ . The *path* of order  $n$ , denoted by  $P_n$ , is a graph  $G = (V, E)$  of the form  $V = \{v_1, v_2, \dots, v_n\}$  and  $E = \{v_1v_2, v_2v_3, \dots, v_{n-1}v_n\}$ . The *cycle* of order  $n$ , denoted by  $C_n$ , is  $P_n$  plus the edge  $v_nv_1$ . Observe that the previous definitions refer to *abstract graphs*. When we deal in practice with these graphs, we say a *copy* of a  $K_n, P_n$ , or  $C_n$ , or simply a  $K_n, P_n$ , or  $C_n$ . Moreover, given two graphs  $G$  and  $H$ , we say that a graph  $G$  contains a  $H$  if  $H$  is (simply) a subgraph of  $G$ , while  $G$  contains an induced  $H$  if  $H$  is an induced subgraph of  $G$ .

## 0.4 Complexity

In this manuscript, we use notions and results from *Computational Complexity Theory*. In this section, we give a brief introduction to the main concepts. We refer to [27] for more details.

Studying a problem, particularly one related to a family of geometric objects or a graph, we would like to distinguish between problems that are “tractable” or “hard” to solve. We say that a problem is “tractable”, or *polynomial-time solvable* if there is an algorithm that finds an optimal solution to the problem with worst-case running time bounded by a polynomial function of the input size. The class of all polynomial-time solvable problems is denoted by  $\mathcal{P}$ . Non-trivial examples of problems in  $\mathcal{P}$  are computing the stability number and the clique covering number of a bipartite graph.

The time spent by an algorithm depends on the representation of the data it deals with. Fortunately, this does not cause any trouble: for graphs and families of geometric objects, all the classical models are equivalent from this point of view.

Before arriving at a formal definition of “hard” problems, we need to make a little detour. A *decision problem* is a problem whose answer is either “yes” or “no”. The class  $\mathcal{NP}$  is the class containing all the decision problems for which the “yes” answer is *verifiable*, that is, there is a certificate that validates the solution and can be verified in time polynomial in the size of the input problem. Any decision problem in  $\mathcal{P}$  is also in  $\mathcal{NP}$  since the polynomial algorithm that solves it can be used as a solution certificate.

Given two decision problems  $A$  and  $B$ , we say that  $A$  can be *Karp-reduced*, or simply *reduced*, to  $B$  if there is a transformation that takes an instance of  $A$  and returns an instance of  $B$  with the following properties:

- the transformation takes a time that is polynomial in the input size of  $A$ ;
- the input size of  $B$  is polynomial in the input size of  $A$ ;
- the problem  $A$  and its reduction to  $B$  have the same answer.

Finally, a problem is “hard”, or  *$\mathcal{NP}$ -hard*, if any problem in  $\mathcal{NP}$  can be reduced to it. The class  *$\mathcal{NP}$ -complete* contains the problems that are in  $\mathcal{NP} \cap \mathcal{NP}$ -hard.

In 1971, at the very dawn of Computational Complexity Theory, Cook [26] asked the following question:

Is  $\mathcal{P}$  equal to  $\mathcal{NP}$ ?

More than fifty years later, this is still one of the most intriguing research problems in theoretical computer science and one of the seven *Millennium Prize Problems* selected by the Clay Mathematics Institute.

The majority of the problems we deal with are  $\mathcal{NP}$ -complete, so we also explore approximation algorithms. Given a certain problem  $A$ , an *approximation algorithm* for  $A$  is a polynomial-time algorithm that finds a solution  $APP$  to the problem with the property that the optimum value  $OPT$  is “not too far” from it. More precisely, there is a positive integer  $k$  such that  $\frac{OPT}{APP} \leq k$  if  $A$  is a maximization problem, or  $\frac{APP}{OPT} \leq k$  if  $A$  is a minimization problem. In this case, we say that the algorithm is a  $k$ -approximation algorithm. A problem has a *polynomial-time approximation scheme*, or simply *PTAS*, if for any fixed  $\epsilon > 0$  there is a  $1 + \epsilon$  approximation algorithm.

## 0.5 Problems

In this section, we approach the problem of bounding  $\chi$  and  $\tau$  in terms of  $\omega$  and  $\nu$ , respectively. After analyzing the situation in the general case of graphs (with no additional

assumptions), in Section 0.5.1 we borrow the concept of degenerate graphs from graph theory and show how to use it to address our problems. This concept will prove useful in later chapters. Then, in Sections 0.5.2 and 0.5.3 we analyze the relationship between the parameters of families of geometric objects in two special cases: intervals and segments.

Given  $\mathcal{C}$  a class of families of geometric objects, or a class of graphs, we say that  $\mathcal{C}$  is  $\chi$ -bounded if there exists a *binding function*  $f$  such that for every  $C \in \mathcal{C}$ ,  $\chi(C) \leq f(\omega(C))$ . The function  $f$  is *optimal* if there is a  $C \in \mathcal{C}$  with  $\chi(C) = f(\omega(C))$ . Similarly,  $\mathcal{C}$  is  $\tau$ -bounded (resp.  $\theta$ -bounded for graphs) if there exists a *binding function*  $f$  such that for every  $C \in \mathcal{C}$ ,  $\tau(C) \leq f(\nu(C))$  (resp.  $\theta(C) \leq f(\alpha(C))$ ),  $f$  is optimal if there is a  $C \in \mathcal{C}$  with  $\tau(C) = f(\nu(C))$  (resp.  $\theta(C) = f(\alpha(C))$ ).

Tutte (1945) and Zykov (1947) proved independently that the class of all graphs is not  $\chi$ -bounded (see [73]) by showing that there exist graphs with a fixed clique number and an arbitrarily large chromatic number. We report here a stronger result of Erdős. The *girth* of a graph  $G$ , denoted by  $g(G)$ , is the minimum size of a cycle contained in  $G$ . Clearly, if  $g(G) \geq 4$ , then  $G$  does not contain any copy of  $K_3$ , so  $\omega(G) \leq 2$ .

**Theorem 0.3** (Erdős, 1959). *For every integer  $k \geq 3$ , there exists a graph  $G$  with  $g(G) > k$  and  $\chi(G) > k$ .*

Taking the complement of the graphs in Theorem 0.3, we have that the class of all graphs is not  $\theta$ -bounded either.

**Corollary 0.4.** *For every integer  $k \geq 3$ , there exists a graph  $G$  with  $\omega(G) \leq 2$  and  $\chi(G) > k$ . Moreover,  $\alpha(\overline{G}) \leq 2$  and  $\theta(\overline{G}) > k$ .*

The two main questions we investigate in this manuscript are the following.

**Question 0.5.** *Given  $\mathcal{C}$  a class of families of geometric objects, is  $\mathcal{C}$   $\chi$ -bounded? If so, what is the optimal binding function?*

**Question 0.6.** *Given  $\mathcal{C}$  a class of families of geometric objects, is  $\mathcal{C}$   $\tau$ -bounded? If so, what is the optimal binding function?*

Notice that the complement of the intersection graph of a family  $C \in \mathcal{C}$  may not belong to the considered class. Hence,  $\chi$ -boundness and  $\tau$ -boundness are two independent problems.

### 0.5.1 Two useful techniques

Degeneracy can be used to deduce coloring results. Although this is quite a rough, greedy way of coloring, degeneracy is a frequently used method, often providing the best-known way to color geometric intersection graphs [59, 76, 79]. We say that a graph  $G$  is  $k$ -degenerate if for any subgraph  $H$  of  $G$ ,  $\Delta_{\min}(H) \leq k$ . A family  $\mathcal{F}$  of sets is  $k$ -degenerate if its intersection graph is. It is interesting to note that the minimum integer  $k$  for which a graph is  $k$ -degenerate is equal to the maximum of the minimum degree over all subgraphs, and this number can be determined simply by deleting greedily a vertex of minimum degree and then iterating this: the maximum degree in this sequence is the mentioned number.

The following well-known result formulates the use of degeneracy to upper bound the chromatic number.



**Lemma 0.7.** *If a graph  $G$  is  $k$ -degenerate, then  $\chi(G) \leq k + 1$ . In particular, if a family of sets  $\mathcal{F}$  is  $k$ -degenerate, then  $\chi(\mathcal{F}) \leq k + 1$ .*

□

In close analogy with degeneracy for coloring, we say that a family  $\mathcal{F}$  is *hitting- $k$ -degenerate* if for every  $\mathcal{F}' \subseteq \mathcal{F}$  there is a set  $F' \in \mathcal{F}'$  such that  $\tau(N[F']) \leq k$ , meaning that  $F'$  and its neighbors can be hit by at most  $k$  elements. Notice that, since each element is contained in at most  $\Delta(\mathcal{F})$  sets, *hitting- $k$ -degeneracy implies  $k\Delta(\mathcal{F})$ -degeneracy*.

The simple statement analogous to coloring by degeneracy is stated in the following lemma. It formulates the simple and standard induction step, converting the hitting set of the neighbors into a bound on  $\tau$  in terms of  $\nu$ . It has been used more generally for translates of a convex body, see, for instance, the “greedy decomposition” in [60], or [33].

**Lemma 0.8.** *If  $\mathcal{F}$  is a hitting- $k$ -degenerate family of sets, then  $\tau(\mathcal{F}) \leq k\nu(\mathcal{F})$ . Moreover, if  $\tau \leq k_0$  for families satisfying  $\nu(\mathcal{F}) = 1$ , then  $\tau(\mathcal{F}) \leq k_0 + k(\nu(\mathcal{F}) - 1)$ .*

*Proof.* We proceed immediately with the proof of the second statement by induction on  $\nu(\mathcal{F})$ , since then, the first statement follows by substituting  $k_0 := k$ . If  $\nu(\mathcal{F}) = 1$ , then  $\tau(\mathcal{F}) \leq k_0$  by the condition. Assume now that  $\nu(\mathcal{F}) \geq 2$  and that the statements are true for any subfamily  $\mathcal{F}'$  of  $\mathcal{F}$  having  $\nu(\mathcal{F}') < \nu(\mathcal{F})$ . Let  $F \in \mathcal{F}$  be given by the condition, that is,  $N[F]$  can be hit by  $k$  points. Any packing  $\mathcal{I}'$  in  $\mathcal{F} - N[F]$  has size at most  $\nu(\mathcal{F}) - 1$  since  $\mathcal{I}' \cup \{F\}$  is a packing in  $\mathcal{F}$ . Then, since the condition is still satisfied by  $\mathcal{F} - N[F]$ , by the induction hypothesis,

$$\begin{aligned} \tau(\mathcal{F}) &\leq \tau(\mathcal{F} - N[F]) + k \\ &\leq k_0 + k(\nu(\mathcal{F} - N[F]) - 1) \\ &\leq k_0 + k(\nu(\mathcal{F}) - 2) + k \\ &= k_0 + k(\nu(\mathcal{F}) - 1). \end{aligned}$$

□

### 0.5.2 Intervals in a line

A graph  $G$  is an *interval graph* if it is the intersection graph of a family of intervals in a line. Interval graphs are used in multiple applications such as scheduling, chemicals storage, and sequence dating [44].

One of the simplest ways to establish a bound between  $\chi$  and  $\omega$ , and  $\tau$  and  $\nu$ , is to use degeneracy. This technique allows generalizing a local property verified in the neighborhood of a vertex to the whole graph. For a family of intervals, this approach is sufficient to prove equality between the studied parameters. In other situations, such as segments in the plane lying in at most a fixed number of directions, this local technique only allows rough approximations of  $\chi$  and  $\tau$ .

**Lemma 0.9.** *Let  $\mathcal{I}$  be a family of intervals in a line and  $L \in \mathcal{I}$  an interval with a left-most right endpoint  $p$ . Then the neighbors of  $L$  contain  $p$ ,  $|N(L)| \leq \omega(\mathcal{I}) - 1$ , and  $\tau(N[L]) = 1$ .*

□

Let  $\mathcal{I}$  be a family of intervals in a line and  $G$  its intersection graph. Lemma 0.9 states that  $\mathcal{I}$  is  $(\omega(\mathcal{I}) - 1)$ -degenerate and also hitting-1-degenerate. Then, the following two

theorems, originally proved by Gallai in an unpublished manuscript (as reported in [49]), are immediate consequences of Lemmas 0.7 and 0.8.

**Theorem 0.10.** *Let  $\mathcal{I}$  be a family of intervals in a line. Then  $\chi(\mathcal{I}) = \omega(\mathcal{I})$ .*

**Theorem 0.11.** *Let  $\mathcal{I}$  be a family of intervals in a line. Then  $\tau(\mathcal{I}) = \nu(\mathcal{I})$ .*

From the inductive argument used to prove Lemmas 0.7 and 0.8 we can also deduce two polynomial-time algorithms to compute  $\chi$  and  $\tau$  for a family of intervals [47].

### 0.5.3 Segments in the plane

Shifting from a line to the plane, things change drastically. Even the two extreme cases of segments, the “thinnest” rectangle, and squares, the “fattest” rectangles, are unexpectedly difficult. In this section, we show that for segments in the plane, the ratio between the hitting number and the packing number, as the one between the chromatic number and the maximum degree, can be arbitrarily large. Later on, in Chapter 3 we will study these ratios for squares.

Segments in the plane do not have the Helly property. Exploiting this, we can construct families of pairwise intersecting segments with no three segments meeting at a point, and arbitrarily large ratios  $\frac{\chi}{\omega}$  and  $\frac{\tau}{\nu}$  (see Figure 7) [76].

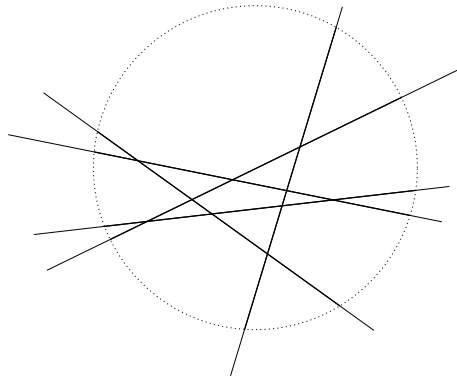

Figure 7: A family of  $n$  segments with  $\Delta = 2$ ,  $\chi = n$ , and  $\nu = 1$ ,  $\tau = \lceil n/2 \rceil$ . It can be constructed by taking  $n$  lines in general position and considering the intersection between them and a large disk containing all the intersection points.

The previous example gives information about the property we can expect from a family of segments in the plane. Still, since the segments are pairwise intersecting, it does not say much about the intersection graph of the family. In the 70s, Erdős asked if the intersection graph of a family of segments is  $\theta$ -bounded and  $\chi$ -bounded.

Pach and Törőcsik [77] proved that this class of graphs is  $\theta$ -bounded.

**Theorem 0.12** (Pach and Törőcsik, 1994). *Let  $G$  be a segment graph. Then,  $\theta(G) \leq \alpha(G)^4$ .*

The second part of Erdős’s question was answered in the negative in [78].

**Theorem 0.13** (Pawlik, Kozik, Krawczyk, Lasoń, Micek, Trotter, and Walczak, 2013). *For each positive integer  $k$ , there exists a triangle-free family of segments in the plane with chromatic number  $\chi \geq k$ .*



# Chapter 1

## Axis-parallel rectangles

In this chapter, we discuss axis-parallel rectangles. The interest in this kind of object has a twofold origin. Besides offering a reasonably simple model into which to transform many practical problems (e.g. [1, 58, 68], and Section 0.1), axis-parallel rectangles have captured the attention of researchers for several decades with appealing open problems about their combinatorial structure. Reducing ourselves to the study of coloring and packing rectangles, the earliest traces of these themes date back to 1948 and 1965, respectively. In 1948, Bielecki [10] asked if any family of axis-parallel rectangles with a triangle-free intersection graph could be colored with a fixed number of colors; while in 1965, Wegner [90] proposed a more precise relationship between the hitting and the packing number of rectangles. He conjectured that the hitting number of any family of axis-parallel rectangles can be bounded by twice its packing number minus one,  $\tau \leq 2\nu - 1$ .

The purpose of this chapter is to outline the main recent progress in these areas and discuss open problems related to interesting sub-cases. In the first part of this chapter, we focus on the relationship between the chromatic number and the clique number, while in the second, we address the hitting number and the packing number.

The seminal work of Asplund and Grünbaum offered the first bound on the chromatic number of axis-parallel rectangles. Even if their paper dates back to 1960, it contains methods and ideas that are still valuable today. In Section 1.1, we present their work and integrate it with the best-known upper and lower bounds on  $\chi$  using  $\omega$ . An overview of the proofs in this part will put forward the existence of various kinds of intersections that can occur between two rectangles. In particular, we will deal with the case where all rectangles have only *crossing intersections* or only *corner intersections*. In Section 1.1.1, we present the results of Asplund and Grünbaum on the triangle-free case. This will be the occasion to highlight an interesting relationship between planar graphs and geometric intersection graphs without triangles. We conclude this part with Section 1.1.2 discussing rectangles with a bounded aspect ratio. A classical result of Pach implies that the ratio  $\chi/\omega$  for this kind of family is bounded by a constant depending linearly on the aspect ratio of the family. We improve this dependency from linear to logarithmic.

We follow a similar structure in the part dedicated to hitting and packing. Section 1.2 starts with an overview of the best bounds on  $\tau$  available in the literature. Finding lower bounds for the ratio  $\tau/\nu$  is a difficult task. We report an example of Jelínek showing that this ratio is at most 2. We continue offering partial results on interesting families. In Section 1.2.1, we improve a bound of Chudnovsky, Spirkl, and Zerbib [23] about rectangles

with corner intersections. Then, in Section 1.2.2, we observe that the coloring techniques used for rectangles with a bounded aspect ratio also imply a bound on  $\tau/\nu$ . This new result will offer a proof (and a considerable improvement) to a statement of Ahlswede and Karapetyan [2]. Finally, in Section 1.2.3, we prove two simple bounds on the hitting number, and we use them to convert results on the chromatic number into results for the hitting number. In particular, we analyze the case when the intersection graph is triangle-free. Since Wegner's conjecture is still not settled, the investigation of particular cases, such as restricting the possible intersections, or forbidding subfamilies, could be a source of new intuitions to better understand the general framework.

A first insight into the behavior of axis-parallel rectangles can be gained by highlighting their relationship with intervals in a line. Clearly, an axis-parallel rectangle  $R$  is the Cartesian product of two intervals, one lying in the horizontal axis  $p_1(R)$  and one in the vertical axis  $p_2(R)$ .

**Fact 1.1.** *A pair of axis-parallel rectangles  $R, R'$  intersects if and only if  $p_1(R) \cap p_1(R') \neq \emptyset$  and  $p_2(R) \cap p_2(R') \neq \emptyset$ .*

This straightforward observation can be used to derive a rough bound between  $\tau$  and  $\nu$  and the hitting result for intervals we described in Section 0.5 (Theorem 0.11).

**Proposition 1.2.** *Let  $\mathcal{R}$  be a family of axis-parallel rectangles, then*

$$\tau(\mathcal{R}) \leq \nu(\mathcal{R})^2.$$

*Proof.* Consider the two families of intervals  $\mathcal{I}_1 := \{p_1(R) : R \in \mathcal{R}\}$  and  $\mathcal{I}_2 := \{p_2(R) : R \in \mathcal{R}\}$ . By Theorem 0.11 and Fact 1.1, for  $i \in \{1, 2\}$ ,  $\tau(\mathcal{I}_i) = \nu(\mathcal{I}_i) \leq \nu(\mathcal{R})$ . The Cartesian product of a hitting set of  $\mathcal{I}_1$  and a hitting set of  $\mathcal{I}_2$  hits all rectangles in  $\mathcal{R}$ , so

$$\tau(\mathcal{R}) \leq \tau(\mathcal{I}_1)\tau(\mathcal{I}_2) \leq \nu(\mathcal{R})^2.$$

□

The upper bound in Proposition 1.2 is inaccurate for large values of  $\nu$ , but it is interesting for small values. In particular, for  $\nu = 1$ , it says that any family of pairwise intersecting axis-parallel rectangles can be hit by one point, that is, axis-parallel rectangles have the *Helly property*.

Observe that Proposition 1.2 can be easily generalised to higher dimension: *for any family of axis-parallel boxes  $\mathcal{B}$  in  $\mathbb{R}^d$ ,  $\tau(\mathcal{B}) \leq \nu(\mathcal{B})^d$* . Consequently, the Helly property still holds also for multi-dimensional boxes.

## 1.1 Coloring rectangles

A classical result, proved independently by Tutte and Zikov (see Section 0.5), states that there are graphs with a fixed clique number  $\omega$  and an arbitrarily large chromatic number  $\chi$ . In 1948, Bielecki [10] asked about the relation of  $\chi$  and  $\omega$  for the intersection graphs of axis-parallel rectangles. Unlike the relationship between  $\tau$  and  $\nu$ , studying the projections of the rectangles on the axes gives practically no hint about that. However, it did not take long for a solution to be found. In 1960 Asplund and Grünbaum [7] showed that a bound on  $\chi$  by using  $\omega$  is possible, even with a polynomial function.

**Theorem 1.3** (Asplund and Grünbaum, 1960). *Let  $\mathcal{R}$  be a family of axis-parallel rectangles, then*

$$\chi(\mathcal{R}) \leq 4\omega(\mathcal{R})^2 - \omega(\mathcal{R}).$$

The bound in Theorem 1.3 remained essentially optimal for almost 60 years. Only recently Chalermsook and Walczak [18] improved it showing that  $\chi = \mathcal{O}(\omega \log(\omega))$ . The proof of their result is based on a smart *divide and conquer* approach that allows to bound

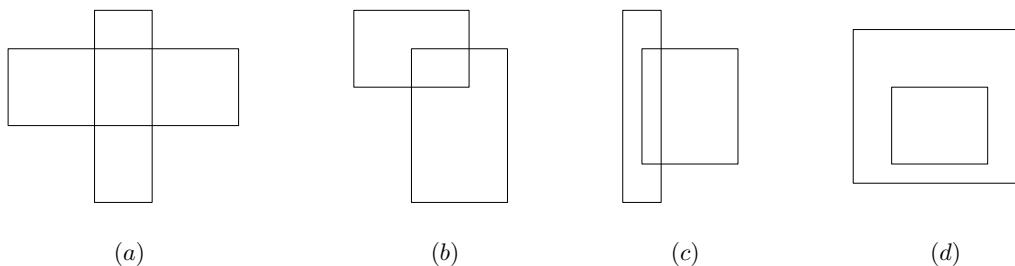

Figure 1.1: Different types of intersection between axis-parallel rectangles.

the clique number of the family's sub-classes and so color them separately with “few” colors.

Kostochka [62], Krawczyk and Walczak [66] constructed families of rectangles with chromatic number  $\chi = 3\omega$  and  $\chi = 3\omega - 2$ , respectively. *Closing the gap between the linear lower bound and the super-linear upper bound is an interesting open problem.* Also, simply improving the lower bound would be a significant result.

**Question 1.4.** *Is there a family of axis-parallel rectangles with  $\chi > 3\omega$ ?*

This section is dedicated to studying the coloring property of rectangles when additional conditions are required between the intersection of pairs. These results will give a better understanding of the behavior of axis-parallel rectangles and simultaneously provide the basis for the proof of Theorem 1.3.

Besides the properties of the intersection graph, geometric objects have interesting behavior related to how objects intersect. To familiarize ourselves with the different types of intersections, we find appropriate names for each of them.

Let  $S, Q$  be two intersecting axis-parallel rectangles. We say that  $S$  and  $Q$  *cross*, or have a *crossing intersection*, if  $S \cap Q$  contains none of the eight corners of  $S$  and  $Q$ . Equivalently,  $S$  and  $Q$  cross if  $p_1(S) \subset p_1(Q)$  and  $p_2(Q) \subset p_2(S)$ , or vice-versa (see Figure 1.1 (a)). In particular, *two axis-parallel squares cannot cross*.

If  $S$  and  $Q$  do not cross, we say they have a *corner intersection*. We can differentiate between three types of corner intersections: Figure 1.1 (b), (c), and (d).

**Fact 1.5.** *If two axis-parallel rectangles  $S, Q$  have a corner intersection, then  $S \cap Q$  contains at least two of the eight corners of  $S$  and  $Q$ .*

A family of rectangles is said to be *crossing* if it has only crossing intersections, while it is said to be *cross-free* if it has only corner intersections. Adding restrictions on the intersection of a family of rectangles simplifies the coloring problem drastically. In Lemmas 1.6 and 1.7, we analyze the case when only crossing, or only corner, intersections are allowed.

**Lemma 1.6** ([7]). *Let  $\mathcal{R}$  be a family of axis-parallel rectangles and  $G$  the subgraph of  $G(\mathcal{R})$  whose edges consist only of crossing intersections. Then  $G$  is a comparability graph. In particular, if  $\mathcal{R}$  is a crossing family, then  $\chi(\mathcal{R}) = \omega(\mathcal{R})$  and  $\tau(\mathcal{R}) = \nu(\mathcal{R})$ .*

*Proof.* A comparability graph is a graph that links pairs of vertices that are comparable in a partial order. To prove the lemma, we define the following relation  $\preceq$  on the rectangles in  $\mathcal{R}$ : given  $S, Q \in \mathcal{R}$ ,  $S \preceq Q$  if and only if  $S$  and  $Q$  have a crossing intersection and

$p_1(S) \subseteq p_1(Q)$ . It is easy to observe that this relation is *reflexive*, *anti-symmetric* and *transitive*. Hence,  $\mathcal{P} := (\mathcal{R}, \preceq)$  is a poset. Moreover, its comparability graph is isomorphic to  $G$ , concluding the first part of the proof.

Now, assume that  $\mathcal{R}$  is a crossing family, in particular  $G = G(\mathcal{R})$ . Since any pair of intersecting rectangles is crossing, there is a one-to-one relation between *chains* in  $\mathcal{P}$  and *cliques* in  $\mathcal{R}$ , and between *anti-chains* and *packings*. Finally, the two bounds in the statement follow directly from the well-known theorems of Mirsky [71] and Dilworth [31], respectively.  $\square$

For a cross-free family, we can bound the chromatic number using a linear function of the clique number. The proof adapts the *averaging argument* used by Asplund and Grünbaum in [7], exhibited in an elegant way by Chalermsook and Walczak [18, Lemma 3].

This same technique will be useful in other parts of the manuscript (e.g. Sections 3.4 and 3.5). It is also possible to prove that the relation between  $\tau$  and  $\nu$  is linear, but since the proof is more involved, we postpone the result to Section 1.2.1.

**Lemma 1.7** ([7], [18]). *Let  $\mathcal{R}$  be a family of axis-parallel rectangles. If  $\mathcal{R}$  is cross-free and  $\omega(\mathcal{R}) \geq 2$ , then  $\chi(\mathcal{R}) \leq 4(\omega(\mathcal{R}) - 1)$ .*

*Proof.* Let  $G := G(\mathcal{R})$  be the intersection graph of  $\mathcal{R}$ ,  $n := |\mathcal{R}|$ . Each point of a rectangle can be contained in at most  $\omega(\mathcal{R}) - 1$  other rectangles with some strict inequalities at the borders (for example, the left-most point that is a corner of a rectangle cannot be contained in any other rectangle). For each rectangle  $R \in \mathcal{R}$  and each of the four corners  $v$  of  $R$  we count the pairs  $(v, R')$ , where  $R'$  is a neighbor of  $R$  containing  $v$ . The quantity obtained from counting is strictly less than  $4(\omega(\mathcal{R}) - 1)n$ .

*This sum counts each edge at least twice.* Indeed, the family  $\mathcal{R}$  is cross-free, and when two rectangles have a corner intersection, at least two of their eight corners are contained in the intersection (Fact 1.5), so at least two pairs correspond to the intersection. Hence,  $2|E| < 4n(\omega(\mathcal{R}) - 1)$  and therefore  $\Delta_{\min}(G) < 4(\omega(\mathcal{R}) - 1)$ . The same argument can be repeated for any subfamily of  $\mathcal{R}$  implying that the family is  $k$ -degenerate for  $k \leq 4(\omega(\mathcal{R}) - 1) - 1$ . Finally, Lemma 0.7 concludes the proof.  $\square$

Now, the proof of Theorem 1.3 is a simple combination of the previous two lemmas, it follows with no additional effort.

*Proof of Theorem 1.3.* Let  $H$  be the subgraph of the intersection graph of  $\mathcal{R}$  whose edges consist only of crossing intersections. Lemma 1.6 implies that  $H$  is a comparability graph, so we can partition the rectangles, corresponding to the vertices in  $H$ , in  $\omega(H) \leq \omega(\mathcal{R})$  classes with the property that no pair of rectangles in the same class has a crossing intersection. Hence, by Lemma 1.7 each class can be properly colored with a set of at most  $4(\omega(\mathcal{R}) - 1)$  distinct colors. This gives a coloring of  $\mathcal{R}$  with at most  $4\omega(\mathcal{R})^2 - \omega(\mathcal{R})$  colors.  $\square$

### 1.1.1 Triangle-free families

In this section, we study the case when the intersection graph  $G$  of the family is *triangle-free*, that is,  $G$  has no  $K_3$  as subgraph or equivalently, by the Helly property, no three rectangles meet at a point. We call such a family *triangle-free*. Since  $K_3$  is contained in every larger clique  $K_n$  for  $n \geq 3$ ,  $\omega(\mathcal{R}) \leq 2$ .



Theorem 1.3 implies that a triangle-free family of axis-parallel rectangles is 14-colorable. In the same paper where Theorem 1.3 appeared [7], Asplund and Grünbaum proved a tight result for triangle-free families of rectangles.

**Theorem 1.8** (Asplund and Grünbaum, 1960). *Let  $\mathcal{R}$  be a triangle-free family of axis-parallel rectangles. Then  $\chi(\mathcal{R}) \leq 6$ . Moreover, there are triangle-free families with a chromatic number of 6.*

The example constructed to show that the bound in Theorem 1.8 is tight is rather ingenious. Details about the construction can be found in the original paper [7] or in [48]. We only give the proof of the first part of the theorem. After giving the details of the original proof, we present an alternative one that builds on a connection between triangle-free families and planar graphs.

Given  $\mathcal{R}$  a triangle-free family of axis-parallel rectangles, we say that a rectangle is of a *vertical type* (resp. *horizontal type*) if no other rectangle intersects both its horizontal (resp. vertical) sides. It is easy to check that the *triangle-free property* implies that any rectangle in  $\mathcal{R}$  has at least one type. Moreover, if a pair of rectangles has a crossing intersection, then they have different types: the thinner (smaller width) is of a vertical type, and the larger is of a horizontal type.

We can cover  $\mathcal{R}$  with two subfamilies: the family  $\mathcal{A}$  of vertical type rectangles and the family  $\mathcal{B}$  of horizontal type rectangles.

**Lemma 1.9.** *The subfamilies  $\mathcal{A}$  and  $\mathcal{B}$  are both 2-degenerate.*

*Proof.* Let  $R$  be the rectangle in  $\mathcal{A}$  having left-most right corners. Any rectangle  $Q \in \mathcal{A}$  intersecting  $R$  has to contain the top-right corner or the bottom-right corner of  $R$ . Hence, any rectangle in  $N[R] \cap \mathcal{A}$  is hit by one of the two right corners of  $R$ . Since  $\mathcal{A}$  is a triangle-free family, both the right corners of  $R$  can be contained in at most one other rectangle,  $|N(R) \cap \mathcal{A}| \leq 2$ . Repeating this argument for any subfamily of  $\mathcal{A}$ , we can conclude that the family is 2-degenerate. By symmetry,  $\mathcal{B}$  is 2-degenerate by iteratively considering a rectangle having bottom-most top corners.  $\square$

*Original Proof of Theorem 1.8.* Consider a triangle-free family  $\mathcal{R}$  of axis-parallel rectangles and let  $\mathcal{A}$  be the family containing the vertical type rectangles of  $\mathcal{R}$  and  $\mathcal{B}' := \mathcal{R} - \mathcal{A}$  (a subfamily of  $\mathcal{B}$  in Lemma 1.9). By Lemma 1.9 followed by Lemma 0.7,  $\mathcal{A}$  and  $\mathcal{B}'$  are 3-colorable. Coloring  $\mathcal{A}$  and  $\mathcal{B}'$  with two separate sets of 3 colors, we obtain a proper coloring of  $\mathcal{R}$  with 6 colors.  $\square$

Another way to prove Theorem 1.8 is to focus on the subclass of cross-free triangle-free families. A result of Pereplitsa [79] shows a natural connection between this subclass and triangle-free planar graphs.

**Lemma 1.10** (Pereplitsa, 2003). *Let  $G$  be the triangle-free intersection graph of a finite number of compact connected sets  $A_i$  with boundaries that are piece-wise differentiable Jordan curves. If for every  $i$  and  $j$ ,  $A_i \setminus A_j$  is non-empty and connected, then  $G$  is a planar graph.*

Even if it is possible to construct “artificially” convex sets with boundaries that are not piece-wise differentiable, almost any convex objects we can think about satisfies this property. In particular, rectangles and also polygons with  $k \in \mathbb{N}$  sides satisfy it.

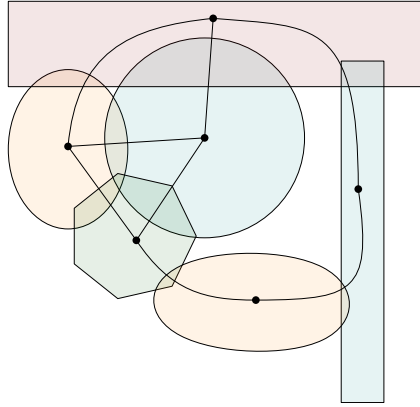

Figure 1.2: A family of convex sets with the underlying planar graph.

**Theorem 1.11.** *Let  $G$  be the triangle-free intersection graph of a finite family of axis-parallel rectangles  $\mathcal{R}$ . If  $\mathcal{R}$  is cross-free, then  $G$  is a planar graph. In particular,  $\chi(G) \leq 3$ .*

*Proof.* We can assume that no rectangle in  $\mathcal{R}$  is contained in another rectangle. Indeed, if there are  $S, Q \in \mathcal{R}$  and  $S \subseteq Q$ , then we can temporarily remove  $S$  from the family. Since  $S$  cannot have any neighbors other than  $Q$ , we can add it back at the end without impacting either the planarity of the graph or its 3-colorability.

If two rectangles  $S, Q$  have a corner intersection and  $S \not\subseteq Q$ , then  $S \setminus Q$  is connected and not empty. Then, Lemma 1.10 implies that the intersection graph  $G$  is planar. Further,  $G$  is triangle-free, so by Grötzsch's Theorem [45],  $\chi(G) \leq 3$ .  $\square$

**Corollary 1.12.** *Let  $\mathcal{S}$  be a triangle-free family of axis-parallel squares. Then  $\chi(\mathcal{S}) \leq 3$ .*

*Alternative Proof of Theorem 1.8.* Let  $H$  be the subgraph of the intersection graph of  $\mathcal{R}$  whose edges consist only of crossing intersections. The subgraph  $H$  is triangle-free, and by Lemma 1.6, it is also a comparability graph. Hence, we can partition the rectangles into two cross-free classes, say  $\mathcal{A}$  and  $\mathcal{B}$ . By Theorem 1.11,  $\mathcal{A}$  and  $\mathcal{B}$  can both be colored with two separate sets of 3 colors. These 6 colors define a proper coloring of  $\mathcal{R}$ .  $\square$

Even if the constant of 6 cannot be improved for triangle-free families of rectangles, strengthening the hypothesis in a similar direction allows better coloring. Recall that the girth of a graph  $G$  is the minimum size of a cycle contained as a subgraph in  $G$ . Clearly, triangle-free graphs have a girth of at least 4.

**Theorem 1.13** (Kostochka and Pereplitsa, 2000 [63]). *Let  $G$  be the intersection graph of a finite family of axis-parallel rectangles  $\mathcal{R}$ . If  $G$  has girth at least 6, then  $\chi(G) \leq 4$ . Moreover, if  $G$  has girth at least 8, then  $\chi(G) \leq 3$ .*

The ratio of  $\tau$  to  $\nu$  is well understood for small values of  $\nu$  (as we will see in Theorem 1.20). For  $\chi$  and  $\omega$ , it is not the same: although Theorem 1.8 settles the problem of coloring axis-parallel rectangles for  $\omega = 2$ , already for  $\omega$  fixed at 3 we do not know what the best bound for the chromatic number is.

**Question 1.14.** *Is any family of axis-parallel rectangles with  $\omega \leq 3$  colorable with at most 9 colors?*

### 1.1.2 Rectangles with a bounded aspect ratio

The *aspect ratio* of a rectangle is the ratio between its longer and shorter side. Clearly, a rectangle has an aspect ratio of 1 if and only if it is a square. We denote the *aspect ratio* of a rectangle  $R$  by  $\rho(R)$ , and by  $L(R)$  (resp.  $l(R)$ ) the length of the larger (resp. smaller) side of  $R$ , so  $\rho(R) = \frac{L(R)}{l(R)}$ . The intuition is that a rectangle  $R$  with aspect ratio  $\rho$  behaves roughly as a set of  $\lceil \rho \rceil$  squares. Indeed, interesting properties for rectangles with a bounded aspect ratio can be obtained with techniques similar to the ones used for squares. In this section, we prove that for these kinds of families, the ratio  $\chi/\omega$  is bounded by a constant depending on the aspect ratio. Then, in Section 1.2.2 the same will be done for the ratio  $\tau/\chi$ . These results are based on joint work with András Sebő [16].

In 1980 Pach [76] proved that if a family of convex sets  $\mathcal{F}$  has the property that, for any set of  $\mathcal{F}$ , the ratio between the area of the smallest circle containing it and its area is at most a fixed constant  $q$ , then  $\chi(\mathcal{F}) \leq 9q\omega(\mathcal{F})$ . For a rectangles with an aspect ratio  $\rho$ ,  $q$  is bounded by  $\frac{\pi}{4}(\rho + 1/\rho)$ . In terms of the aspect ratio, Pach's result gives the bound  $\chi(\mathcal{F}) \leq \frac{9\pi}{4}(\rho + 1)\omega(\mathcal{F})$ .

Partitioning the rectangles according to their aspect ratio, we could improve the dependency on  $\rho$  from linear to logarithmic.

**Theorem 1.15.** *Let  $\mathcal{R}$  be a family of axis-parallel rectangles in the plane with an aspect ratio of at most  $\rho$ . Then,*

$$\chi(\mathcal{R}) \leq 2(\lceil \rho \rceil + 1)(\omega(\mathcal{R}) - 1) + 1.$$

Furthermore, if  $\rho \geq 2$ ,

$$\chi(\mathcal{R}) \leq \lceil \log_2 \rho \rceil (12\omega(\mathcal{R}) - 10),$$

improving the linear bound for  $\rho \geq 30$ .

Before defining the partition, in the following lemma, we show that the family is degenerate and hitting-degenerate.

**Lemma 1.16.** *Let  $\mathcal{R}$  be a family of axis-parallel rectangles in the plane with an aspect ratio of at most  $\rho$ , then  $\mathcal{R}$  is  $k(\omega(\mathcal{R}) - 1)$ -degenerate and hitting- $k$ -degenerate for  $k \leq 2(\lceil \rho \rceil + 1)$ .*

*Proof.* Let  $R$  be a rectangle with the shortest side in  $\mathcal{R}$ , assume this side is its height, and choose it to be the unity:  $L(R) \geq l(R) = 1$ . Define  $P := \{p_1, \dots, p_{\lceil \rho \rceil + 1}, q_1, \dots, q_{\lceil \rho \rceil + 1}\}$  as the set of  $2(\lceil \rho \rceil + 1)$  points:  $\lceil \rho \rceil + 1$  points equally spaced along each of the upper and lower sides of  $R$ , subdividing them into segments of length at most  $\frac{L(R)}{\lceil \rho \rceil} \leq 1$ , and  $\{p_1, p_{\lceil \rho \rceil + 1}, q_1, q_{\lceil \rho \rceil + 1}\}$  coincides with the set of vertices of  $R$  (see Figure 1.3).



Figure 1.3: Definition of the hitting set  $P$ .

Now, any rectangle  $S \in \mathcal{N}[R]$  contains at least one of the points in  $P$ . Indeed, since  $S \cap R \neq \emptyset$ ,  $S$  intersects at least one of the  $\lceil \rho \rceil$  rectangles with vertices in  $P$  partitioning  $R$ .

We denote this rectangle by  $P(R)$ :  $P(R) \cap S \neq \emptyset$ . Since both sides of  $P(R)$  are of length at most one and both sides of  $S$  are of length at least one,  $S$  contains a vertex of  $P(R)$ . Hence,  $S \cap P \neq \emptyset$ , and,  $P$  is a hitting set of  $N[R]$ . Since any point of  $P$  can be contained in at most  $\omega(\mathcal{R}) - 1$  rectangles, besides  $R$ ,  $|N(R)| \leq 2(\lceil \rho \rceil + 1)(\omega(\mathcal{R}) - 1)$ . The same argument can be repeated in any subclass of  $\mathcal{R}$ , showing the degeneracy and hitting-degeneracy claimed in the statement.  $\square$

*Proof of Theorem 1.15.* The first statement follows directly by Lemma 1.16 and the coloring property of degenerate family expressed in Lemma 0.7.

We suppose now that  $\rho \geq 2$  and prove the second part of the theorem. We cover  $\mathcal{R}$  with  $2\lceil \log_2 \rho \rceil$  classes:

$$\begin{aligned} \mathcal{A}_i &:= \{R \in \mathcal{R} : 2^{i-1} \leq \rho \leq 2^i, \text{ and the horizontal side of } R \text{ is of length } L(R)\}, \\ \mathcal{B}_i &:= \{R \in \mathcal{R} : 2^{i-1} \leq \rho \leq 2^i, \text{ and the vertical side of } R \text{ is of length } L(R)\} \end{aligned}$$

for  $i = 1, \dots, \lceil \log_2 \rho \rceil$  some of which may be empty. Apply now a horizontal-homothety with coefficient  $\lambda_i := 1/2^i$  (multiply the horizontal coordinates by  $\lambda_i$ ) to all rectangles in  $\mathcal{A}_i$ , and a vertical-homothety with the same coefficient to the rectangles  $\mathcal{B}_i$ . Denote the families of rectangles consisting of the images of rectangles by  $\mathcal{A}'_i, \mathcal{B}'_i$ . Each of these families has aspect ratio less than 2, so substituting  $\rho = 2$  to the already proven first part,  $\chi(\mathcal{A}'_i) \leq 6(\omega(\mathcal{A}'_i) - 1) + 1$  and  $\chi(\mathcal{B}'_i) \leq 6(\omega(\mathcal{B}'_i) - 1) + 1$ . Therefore we have:

$$\begin{aligned} \chi(\mathcal{R}) &\leq \sum_{i=1}^{\lceil \log_2 \rho \rceil} \left( \chi(\mathcal{A}'_i) + \chi(\mathcal{B}'_i) \right) \leq \sum_{i=1}^{\lceil \log_2 \rho \rceil} \left( 6(\omega(\mathcal{A}'_i) - 1) + 1 + 6(\omega(\mathcal{B}'_i) - 1) + 1 \right) \\ &\leq \sum_{i=1}^{\lceil \log_2 \rho \rceil} \left( 12(\omega(\mathcal{R}) - 1) + 2 \right) \leq \lceil \log_2 \rho \rceil (12\omega(\mathcal{R}) - 10). \end{aligned}$$

$\square$

## 1.2 Hitting rectangles

A long-standing conjecture of Wegner [90] states a much better bound on  $\tau$  than the one proposed in Proposition 1.2.

**Conjecture 1.17** (Wegner, 1965). *Let  $\mathcal{R}$  be a family of axis-parallel rectangles, then*

$$\tau(\mathcal{R}) \leq 2\nu(\mathcal{R}) - 1.$$

The first essential improvement on the bound of Proposition 1.2 was achieved by J. Beck in an unpublished work (see [56] or [38]). He showed that  $\tau = \mathcal{O}(\nu \log^2(\nu))$ . Then, Károlyi [56] further improve the bound to  $\tau = \mathcal{O}(\nu \log(\nu))$ . Károlyi's proof was simplified by Fon-Der-Flaass and Kostochka [38]. Their intuition was to use a *divide and conquer* approach: place a vertical line to divide the plane in two, then solve iteratively the problems for the rectangles strictly to the left and strictly to the right of the line. Once this is done, hit the rectangles intersecting the vertical line by looking at their intersection with it (the resulting interval family can be hit by Theorem 0.11).

**Theorem 1.18** (Fon-Der-Flaass and Kostochka, 1993). *Let  $\mathcal{R}$  be a family of axis-parallel rectangles, then*

$$\tau(\mathcal{R}) \leq \nu(\mathcal{R}) \log_2(\nu(\mathcal{R})) + 2 - \frac{\nu(\mathcal{R})}{2}.$$

Instead of proving the original theorem, we propose the proof of a simpler result that appeared in [3]. This should be sufficient to convey the intuition of the proof, avoiding calculations that are not vital to understanding the idea.

**Proposition 1.19** (Akopyan, 2007). *Let  $\mathcal{R}$  be a family of axis-parallel rectangles. If there are two horizontal lines  $h_1, h_2$  such that every rectangle in  $\mathcal{R}$  intersects at least one of them, then*

$$\tau(\mathcal{R}) \leq \frac{3}{2}\nu(\mathcal{R}).$$

*Proof.* By induction on  $\nu(\mathcal{R})$  with a step of 2. The statement for  $\nu(\mathcal{R}) = 1$  follows from Proposition 1.2, while if  $\nu(\mathcal{R}) \leq 2$ ,  $\tau(\mathcal{R}) \leq 3$  by [49, Proposition 4.1].

Assume  $k := \nu(\mathcal{R}) \geq 3$  and the statement holds for any subfamily of  $\mathcal{R}' \subset \mathcal{R}$  with  $\nu(\mathcal{R}') < k$ . The following partition is at the core of the inductive argument: let  $l_a$  be the vertical line with horizontal coordinate  $a \in \mathbb{R}$ , we denote by  $\mathcal{R}_a^-$  (resp.  $\mathcal{R}_a^+$ ) the subfamilies of rectangles in  $\mathcal{R}$  strictly to the left (resp. to the right) of  $l_a$ , and by  $\mathcal{R}_a := \mathcal{R} \setminus (\mathcal{R}_a^- \cup \mathcal{R}_a^+)$ , that are the rectangles in  $\mathcal{R}$  intersecting  $l_a$ .

Set  $b := \sup_{b \in \mathbb{R}} (\nu(\mathcal{R}_b^-) \leq 1)$ . By the choice of  $b$ , we have that the subfamily of rectangles in  $\mathcal{R}$  to the left of  $l_b$  (not strictly) have a packing number of at least 2. Since these rectangles are disjoint from  $\mathcal{R}_b^+$ ,  $\nu(\mathcal{R}_b^+) \leq k - 2$ . Furthermore,  $\tau(\mathcal{R}_b) \leq 2$  because every rectangle in  $\mathcal{R}_b$  intersects the line  $l_b$  and at least one of the two horizontal lines  $h_1, h_2$ , so it is hit either by  $l_b \cap h_1$ , or  $l_b \cap h_2$  (see Figure 1.4). Finally, applying the inductive hypothesis on  $\mathcal{R}_b^+$ ,

$$\begin{aligned} \tau(\mathcal{R}) &\leq \tau(\mathcal{R}_b^-) + \tau(\mathcal{R}_b^+) + \tau(\mathcal{R}_b) \\ &\leq 1 + \frac{3}{2}(\nu(\mathcal{R}) - 2) + 2 \\ &= \frac{3}{2}\nu(\mathcal{R}). \end{aligned}$$

□

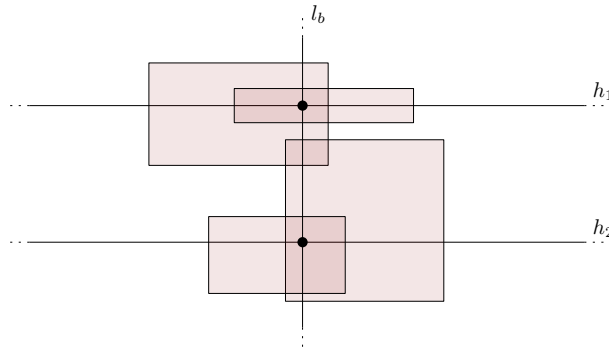

Figure 1.4: Illustration of the lines used in Proposition 1.19.

For small values of  $\nu$ , Theorem 1.18 gives almost optimal bounds.

**Theorem 1.20** (Fon-Der-Flaass and Kostochka, 1993). *Let  $\mathcal{R}$  be a family of axis-parallel rectangles, then*

- if  $\nu(\mathcal{R}) \leq 2$ ,  $\tau(\mathcal{R}) \leq 3$ ;
- if  $\nu(\mathcal{R}) \leq 3$ ,  $\tau(\mathcal{R}) \leq 5$ ;
- if  $\nu(\mathcal{R}) \leq 4$ ,  $\tau(\mathcal{R}) \leq 8$ .

The first two statements imply that Wegner’s conjecture is valid for  $\nu \leq 3$ . It remains open if Wegner’s conjecture holds for  $\nu = 4$ . Recently, Chen and Dumitrescu [20] constructed a family of axis-parallel rectangles with  $\nu = 4$  and  $\tau = 7$ , implying that if the conjecture is true for this particular case, then it is also tight. Inspired by these results, we ask the following question.

**Question 1.21.** *Is there a family of axis-parallel rectangles with  $\nu = 4$  and  $\tau = 8$ , refuting Wegner’s conjecture?*

For larger values of  $\nu$ , the best-known upper bound was proven in [28]. Surprisingly, it comes from a natural combination of two previously known results about  $\tau$  [6] and  $\nu$  [17].

**Theorem 1.22** (Correa, Feuilloley, Pérez-Lantero, and Soto, 2015). *Let  $\mathcal{R}$  be a family of axis-parallel rectangles, then*

$$\tau(\mathcal{R}) = \mathcal{O}(\nu(\mathcal{R}) \log^2 \log \nu(\mathcal{R})).$$

When trying to construct examples with a ratio  $\tau/\nu$  as large as possible, usually the first attempt is a cycle of size 5. This configuration can be achieved for most geometric objects in the plane and has  $\tau = 3 > 2 = \nu$ . It is not apparent how to build better examples than this. Almost thirty years after Wegner stated his conjecture, Fon-Der-Flaass and Kostochka [38] built a sophisticated family of 23 axis-parallel rectangles with  $\tau = 5$  and  $\nu = 3$ . Only recently Jelínek<sup>1</sup> constructed triangle-free families of  $n$  rectangles with ratio  $\tau/\nu$  approaching 2 as  $n$  increases. This family of examples shows that if Wegner’s conjecture is true, then it is also tight. In Section 2.3, we will see how to obtain a similar construction by replacing rectangles with axis-parallel segments.

**Theorem 1.23** (Jelínek, 2015). *There exists a triangle-free family  $\mathcal{J}_k$  of  $4k$  axis-parallel rectangles such that  $\tau(\mathcal{J}_k) = 2k$  and  $\nu(\mathcal{J}_k) = k + 2$ , that is,  $\tau(\mathcal{J}_k) = 2(\nu(\mathcal{J}_k) - 2)$ .*

The proof we report is inspired by the original proof in [28], but it transforms the original case checking into a more direct argument, showing more clearly the peculiarities of the constructed family.

*Proof.* Consider a family of four squares  $\{L, R, U, D\}$  forming a 4-cycle as in Figure 1.5. Note that these four rectangles can be hit by two points and have packing number two.

We construct a set  $\mathcal{J}_k$  of axis-parallel rectangles by arranging  $k \in \mathbb{N}$  copies of  $\{L, U, R, D\}$  into a large square, denote these copies by  $\mathcal{B}_i := \{L_i, R_i, U_i, D_i\}$  ( $i \in \{1, \dots, k\}$ ). The copies are placed on the diagonal of the square, distant enough from one another so that the rectangles in distinct copies are disjoint. After this, the “free ends” of the rectangles are

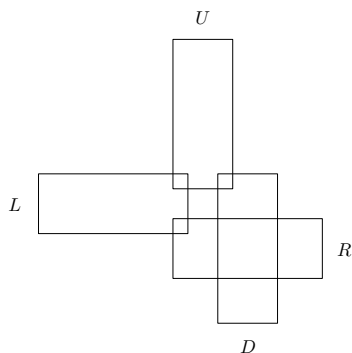
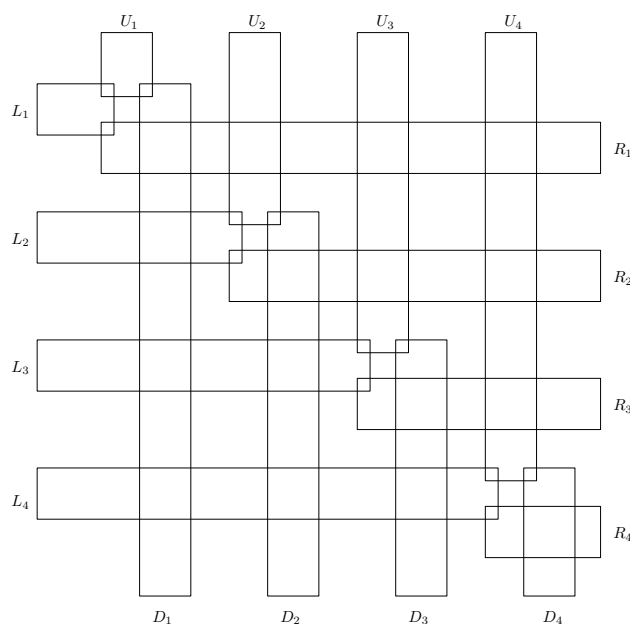

Figure 1.5: Four axis-parallel rectangles forming a cycle.

Figure 1.6: Representation of the family  $\mathcal{J}_4$ .

extended until the borders of the square. Figure 1.6 shows the family obtained by taking 4 copies of the set  $\{L, U, R, D\}$ .

On the one hand,  $\tau(\mathcal{J}_k) = 2k$ , since any point in the plane is contained in at most two rectangles, and the equality holds since we can hit the four rectangles of each of the  $k$  copies of the four rectangles by two points.

On the other hand, we prove  $\nu(\mathcal{J}_k) = k + 2$ . We give a set of  $k + 2$  pairwise disjoint rectangles in  $\mathcal{J}_k$ , showing  $\nu(\mathcal{J}_k) \geq k + 2$ . This packing consists of:

- the rectangles  $L_1$  and  $D_1$  of  $\mathcal{B}_1$ ;
- the rectangles  $R_2$  and  $U_2$  of  $\mathcal{B}_2$ ;
- the rectangle  $R_i$  of  $\mathcal{B}_i$  for  $3 \leq i \leq k$ .

---

<sup>1</sup>Jelínek's example is reported in [28], his contribution is clarified in the *Acknowledgement* of the cited paper.

The size of the intersection between a packing  $\mathcal{P}$  and a copy  $\mathcal{B}_i$  ( $i \in \{1, \dots, k\}$ ) is at most 2. If this is the case, we say that the index  $i$  is *interesting* for  $\mathcal{P}$ . For an interesting index  $i$ , the intersection  $\mathcal{P} \cap \mathcal{B}_i$  coincides either with  $\{L_i, D_i\}$  or  $\{R_i, U_i\}$ .

The number of interesting indices does not depend on the size of  $\mathcal{J}_k$ , a packing  $\mathcal{P}$  can have only two interesting indices. Indeed, if it has at least three, then two of them would be of the same type, say  $\{L_i, D_i\}$  and  $\{L_j, D_j\}$  for  $i < j$ . Then,  $D_i$  intersects  $L_j$  in contradiction with the fact that they both belong to the same packing  $\mathcal{P}$ . Finally, for any packing  $\mathcal{P} \subseteq \mathcal{J}_k$ ,

$$|\mathcal{P}| \leq \sum_{i=1}^k |\mathcal{P} \cap \mathcal{B}_i| \leq 2 + 2 + (k - 2) = k + 2.$$

□

### 1.2.1 Cross-free rectangles

Chan and Har-Peled proved that every family of pseudo-disks (that is, a collection of objects such that the boundary of every pair of them intersects at most twice) in the plane satisfies  $\tau = \mathcal{O}(\nu)$ . Chudnovsky, Spirkl, and Zerbib [23] studied the hitting number of a family of axis-parallel boxes generalizing Chan and Har-Peled's result in higher dimensions and improving the bounds for cross-free axis-parallel rectangles. Notice that cross-free rectangles are indeed pseudo-disks.

**Theorem 1.24** (Chudnovsky, Spirkl, and Zerbib, 2018). *Let  $\mathcal{R}$  be a family of cross-free axis-parallel rectangles. Then  $\tau(\mathcal{R}) \leq 14\nu(\mathcal{R})$ .*

According to Wegner's conjecture (Conjecture 1.17), the constant in Theorem 1.24 would be at most of 2. We take a step in the direction of this conjecture, improving the constant from 14 to 8. Moreover, we believe that a more careful analysis of our proof could give a constant of 6.

**Theorem 1.25.** *Let  $\mathcal{R}$  be a family of cross-free axis-parallel rectangles. Then  $\tau(\mathcal{R}) \leq 8\nu(\mathcal{R})$ .*

*Proof.* Let  $\mathcal{R}$  be a cross-free family of axis-parallel rectangles. We assume without loss of generality that there is no containment because if there are two distinct  $R, R' \in \mathcal{R}$  such that  $R \subseteq R'$  we can remove  $R'$  without changing either  $\tau$  or  $\nu$ .

Let  $\mathcal{M} \subseteq \mathcal{R}$  be a maximum packing that minimizes  $\sum_{M \in \mathcal{M}} u(M)$ , where  $u(M)$  is the vertical coordinate of the upper corners of  $M$ . Due to the cross-free property of the family, we can observe that every pair  $(M, R)$  for  $M \in \mathcal{M}$  and  $R \in \mathcal{R}$  satisfies exactly one of the following statements:

- (1)  $M \cap R = \emptyset$ ;
- (2)  $R$  contains a corner of  $M$ ;
- (3)  $M$  contains exactly two corners of  $R$ .

We start constructing a hitting set of  $\mathcal{R}$  by taking the four corners of the rectangles in  $\mathcal{M}$ . This set has exactly  $4\nu(\mathcal{R})$  points and hits all the rectangles belonging to a pair satisfying Case (2). Let  $\mathcal{R}'$  be the family of rectangles not hit by the corners of the rectangles



in  $\mathcal{M}$ . Since  $\mathcal{M}$  is maximal and only Cases (1) and (3) are possible, every  $R \in \mathcal{R}'$  intersects at least one and at most two rectangles of  $\mathcal{M}$ . According to this property, it is convenient to separate  $\mathcal{R}'$  in smaller units:

If  $R$  intersects exactly one rectangle  $M \in \mathcal{M}$ , we say that  $R$  is *pendant* to  $M$  (see Figure 1.7(a)) and denote the family of the rectangles pendant to  $M$  by  $\mathcal{P}(M)$ ,  $\mathcal{P} := \bigcup_{M \in \mathcal{M}} \mathcal{P}(M)$ . Otherwise,  $R$  intersects two rectangles in  $\mathcal{M}$ , say  $M$  and  $M'$ , and it has exactly two corners in each of them. We say that  $R$  is a *horizontal-bridge* from  $M$  to  $M'$  if  $p_1(M)$  is completely to the left of  $p_1(M')$  (see Figure 1.7(b)), and we denote these rectangles by  $\mathcal{W}_1(M, M')$ ,  $\mathcal{W}_1 := \bigcup_{M, M' \in \mathcal{M}} \mathcal{W}_1(M, M')$ . Similarly, we say that  $R$  is a *vertical-bridge* from  $M$  to  $M'$  if  $p_2(M)$  is completely below  $p_2(M')$  (see Figure 1.7(c)), and we denote these rectangles by  $\mathcal{W}_2(M, M')$ ,  $\mathcal{W}_2 := \bigcup_{M, M' \in \mathcal{M}} \mathcal{W}_2(M, M')$ . Clearly,  $\mathcal{R}' = \mathcal{P} \cup \mathcal{W}_1 \cup \mathcal{W}_2$ .

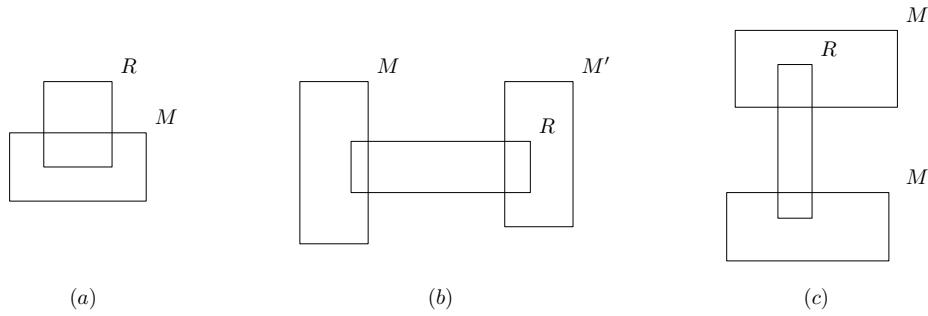

Figure 1.7: From left to right  $R$  is: pendant, a horizontal-bridge from  $M$  to  $M'$ , and a vertical-bridge from  $M$  to  $M'$ .

The set of bridges in  $\mathcal{R}'$  looks almost like a packing. As we show in the following claim, two bridges can intersect only inside a rectangle of  $\mathcal{M}$ .

**Claim 1.** *Let  $R, R'$  be the bridges of two distinct pairs  $(M_1, M_2)$  and  $(M_3, M_4)$ , respectively. If  $R \cap R' \neq \emptyset$ , then there is an index  $i \in \{1, 2, 3, 4\}$  such that  $R \cap R' \subseteq M_i$ , and  $R$  and  $R'$  intersect different sides of  $M_i$ .*

Indeed, we can assume that one corner  $c$  of  $R$  is contained in  $R'$ . Since  $c$  is contained in  $M_1$  or  $M_2$ ,  $R'$  has to intersect one of them, so the pairs  $(M_1, M_2)$  and  $(M_3, M_4)$  have a common rectangle. Assume that  $M_1 = M_3$  (if not, we can reflect the family of rectangles along the origin). Let  $a := R \cap \overset{\circ}{M}_1$  and  $b := R' \cap \overset{\circ}{M}_1$ , where  $\overset{\circ}{M}_1$  is the boundary of  $M_1$ . Recall that  $R, R' \in \mathcal{R}'$  can neither cross nor contain a corner of  $M_1$ , so  $a$  and  $b$  are strictly contained in a side of  $M_1$ . If  $a$  and  $b$  lie on different sides of  $M_1$ , then since they do not cross  $M_1$ , the intersection  $R \cap R'$  is contained in  $M_1$ .

Otherwise,  $a$  and  $b$  lie on the same side of  $M_1$ . In this case,  $R$  and  $R'$  are horizontal-bridges. Hence,  $M_2, M_4$  are on the right of  $M_1$  and since  $c \in R \cap R'$ ,  $a \cap b \neq \emptyset$ . In the horizontal side of  $R$  that contains  $c$ , consider the right-most point that is also contained in  $R'$ , and call this point  $c'$ . We consider two cases according to whether  $c'$  is, or not, a corner of  $R$ . In both cases, we reach a contradiction, showing that  $a$  and  $b$  cannot lie on the same side of  $M_1$ .

*Case (1)* If  $c'$  coincides with a corner of  $R$ , then  $c' \in R \cap R'$  and  $c' \in M_2$ . But  $R'$  can intersect only two elements of  $\mathcal{M}$  so, the pairs  $(M_1, M_2)$  and  $(M_3, M_4)$  coincide, a contradiction.

*Case (2)* If  $c'$  does not coincide with a right corner of  $R$ , then it belongs to a vertical side of  $R'$ . This side is also contained in  $M_4$ , so  $c' \in R \cap M_4 \neq \emptyset$ . Again,  $R$  can intersect only

two elements of  $\mathcal{M}$  so, the pairs  $(M_1, M_2)$  and  $(M_3, M_4)$  coincide, a contradiction. This concludes the proof of the claim.

We can simply bound the packing and hitting numbers in any of the units of  $\mathcal{R}'$ .

**Claim 2.** *For any  $M, M' \in \mathcal{M}$ ,  $\nu(\mathcal{P}(M)) \leq 1$ ,  $\nu(\mathcal{W}_2(M, M')) \leq 2$ , and  $\nu(\mathcal{W}_1(M, M')) \leq 1$ .*

First, since  $M$  is the only rectangle in  $\mathcal{M}$  that is intersected by the elements in  $\mathcal{P}(M)$ , for any packing  $\mathcal{A}$  in  $\mathcal{P}(M)$  the family  $\mathcal{M} \setminus \{M\} \cup \mathcal{A}$  is also a packing. Hence, the maximality of  $\mathcal{M}$  forces  $|\mathcal{A}| \leq 1$ . Similarly, for any packing  $\mathcal{A}$  in  $\mathcal{W}_1(M, M')$ , or in  $\mathcal{W}_1(M, M')$ , the family  $\mathcal{M} \setminus \{M, M'\} \cup \mathcal{A}$  is a packing, so  $|\mathcal{A}| \leq 2$ . Moreover, it is easy to observe that replacing  $M$  and  $M'$  with two disjoint rectangles in  $\mathcal{W}_1(M, M')$  decreases the value of  $\sum_{M \in \mathcal{M}} u(M)$ , so any packing in  $\mathcal{W}_1(M, M')$  can have size at most 1. This concludes the proof of the claim.

**Claim 3.** *For any  $M \in \mathcal{M}$  there exists at most one  $M' \in \mathcal{M}$  with  $\nu(\mathcal{W}_2(M, M')) = 2$ . Moreover,  $\tau(\mathcal{W}_2(M, M') \cup \mathcal{P}(M)) \leq 2$ .*

We start by proving the first statement. Suppose for a contradiction that there are two distinct pairs  $(M, M_1), (M, M_2)$  such that  $\nu(\mathcal{W}_2(M, M_1)) = \nu(\mathcal{W}_2(M, M_2)) = 2$  and let  $\mathcal{A}$  and  $\mathcal{B}$  be two packings of size 2 in  $\mathcal{W}_2(M, M_1)$  and  $\mathcal{W}_2(M, M_2)$ , respectively. If  $\mathcal{A} \cup \mathcal{B}$  is a packing, then also  $\mathcal{M} \setminus \{M, M_1, M_2\} \cup \mathcal{A} \cup \mathcal{B}$  is, contradicting the maximality of  $\mathcal{M}$ . Hence, there are  $A \in \mathcal{A}$  and  $B \in \mathcal{B}$  such that  $A \cap B \neq \emptyset$ . By Claim 1,  $A$  and  $B$  intersect  $M$  on different sides, but this is not possible because all vertical-bridge in  $\mathcal{W}_2(M, M')$  ( $M' \in \mathcal{M}$ ) intersect only the upper side of  $M$ .

Similarly,  $\nu(\mathcal{W}_2(M, M') \cup \mathcal{P}(M)) \leq 2$ . Moreover, a rectangles  $R$  in  $\mathcal{P}(M)$  can intersect only the upper side of  $M$ , otherwise we could replace  $M$  with  $R$  in  $\mathcal{M}$  and find a packing with a smaller value of  $\sum_{M \in \mathcal{M}} u(M)$ . Then, all the rectangles in  $\mathcal{W}_2(M, M') \cup \mathcal{P}(M)$  intersect the upper side of  $M$ , so *two rectangles intersect if and only if their projections on that side intersect*. Instead of hitting the rectangles, we can hit the intervals on the upper side. By Theorem 0.11, if  $\nu(\mathcal{W}_2(M, M') \cup \mathcal{P}(M)) \leq 2$ , two points suffice. This concludes the proof of the claim.

Let  $\alpha$  and  $\beta$  be the number of non-empty classes of type  $\mathcal{W}_1(M, M')$  and  $\mathcal{W}_2(M, M')$ , respectively. By Claim 2, we can use the Helly property to hit the units with packing number 1,

$$\tau(\mathcal{W}_1) \leq \sum_{M, M' \in \mathcal{M}} \tau(\mathcal{W}_1(M, M')) \leq \alpha.$$

Then, by Claim 3, we can hit the vertical-bridges and the pendant rectangles simultaneously,

$$\tau(\mathcal{W}_2 \cup \mathcal{P}) \leq \sum_{M \in \mathcal{M}} \tau\left(\mathcal{P}(M) + \sum_{M' \in \mathcal{M}} \mathcal{W}_2(M, M')\right) \leq \nu(\mathcal{R}) + \beta.$$

Putting together the bounds,

$$\tau(\mathcal{R}) \leq 4\nu(\mathcal{R}) + \tau(\mathcal{R}') \leq 4\nu(\mathcal{R}) + \tau(\mathcal{W}_1) + \tau(\mathcal{W}_2 \cup \mathcal{P}) \leq 5\nu(\mathcal{R}) + \alpha + \beta.$$

Now, it is enough to estimate the number of non-empty units,  $\alpha + \beta$ . Let  $G$  be a graph having  $\mathcal{M}$  as vertex set and an edge between  $M$  and  $M'$  if there is a horizontal-bridge or a vertical-bridge between the two. Observe that  $|E(G)| = \alpha + \beta$  and many bridges

could correspond to the same edge, as can be observed in the example in Figure 1.8. In [23, Lemma 19], a bound on the number of edges in  $G$  was obtained by orienting its edges and then using a well-known property of directed graphs. Here we show that the  $G$  is a planar graph. Euler's formula will then give an upper bound on  $|E(G)|$ .

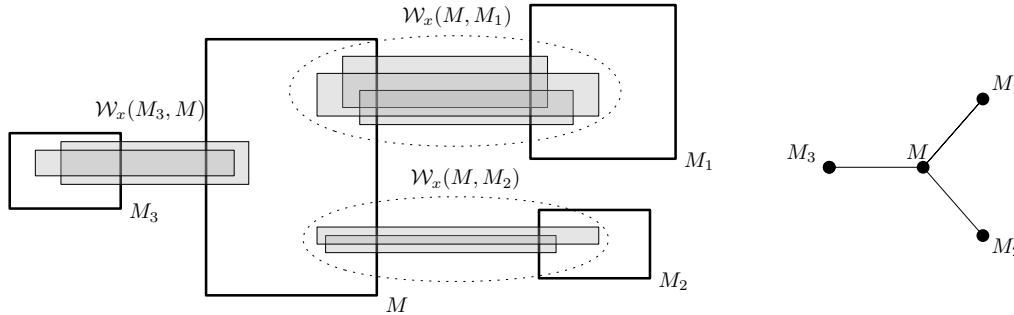

Figure 1.8: Representation of some rectangles in  $\mathcal{M}$  (fat borders) and horizontal-bridges (gray rectangles), and the corresponding subgraph of  $G$ .

**Claim 4.** *The graph  $G$  is planar. As a consequence,  $|E(G)| \leq 3|V(G)| - 6$ .*

Consider the family  $\mathcal{W}'$  of rectangles constructed by taking exactly one rectangle  $R$  from any non-empty  $\mathcal{W}(M, M')$  (either horizontal or vertical bridges) and then removing from  $R$  the interior of  $M$  and  $M'$ . These *reduced rectangles* are still rectangles (as can be observed in Figure 1.7(b,c)) and each of them intersects two rectangles in  $\mathcal{M}$ . By Claim 1, two bridges can intersect only inside a common element of  $\mathcal{M}$ , hence the family of reduced rectangle  $\mathcal{W}'$  is a packing. The intersection graph of  $G' := G(\mathcal{W}' \cup \mathcal{M})$  is isomorphic to the graph obtained by  $G$  by subdividing all its edges (which means replacing each  $uv \in E(G)$  with a path  $u, w, v$  through a new vertex  $w$ ). Clearly,  $G$  is planar if and only if  $G'$  is.

Since  $\mathcal{W}'$  and  $\mathcal{M}$  are two packings,  $G'$  is bipartite and so triangle-free. Moreover,  $\mathcal{W}' \cup \mathcal{M}$  is cross-free since by the definition of  $\mathcal{W}'$  the intersection between a rectangle  $W \in \mathcal{W}'$  and a rectangle  $M \in \mathcal{M}$  is either empty or correspond to a side of  $W$ . We can then apply Theorem 1.11 to conclude that  $G'$  is planar.

The condition  $|E(G)| \leq 3|V(G)| - 6$  is a simple (and well-known) consequence of Euler's formula for planar graphs. This concludes the proof of the claim.

Recall that  $\tau(\mathcal{R}) \leq 5\nu(\mathcal{R}) + \alpha + \beta = 5\nu(\mathcal{R}) + |E(G)|$ , and  $|V(G)| = \nu(\mathcal{R})$ , so Claim 4 concludes the proof.  $\square$

It seems that the proof technique used in the previous theorem may be further pushed to improve the bounds. We believe that the claims also hold under a weaker hypothesis: for example, one could start by using only the top-left and bottom-right corners of the rectangles in  $\mathcal{M}$  (instead of the four corners) to hit the rectangles intersecting more than two elements in  $\mathcal{M}$ . After this, pendant rectangles and bridges could be defined similarly. Such an approach could be enough to prove  $\tau \leq 6\nu$ .

Another idea to further improve the constant is to give better estimates on the number of edges of the graph  $G$ . This seems possible but not easy to prove since it has to use the maximality of  $\mathcal{M}$  cleverly. Indeed, removing the hypothesis that  $\mathcal{M}$  is a maximum packing, one could find a set of rectangles  $\mathcal{R}$  that induces a maximum planar triangulation (see Figure 1.9).

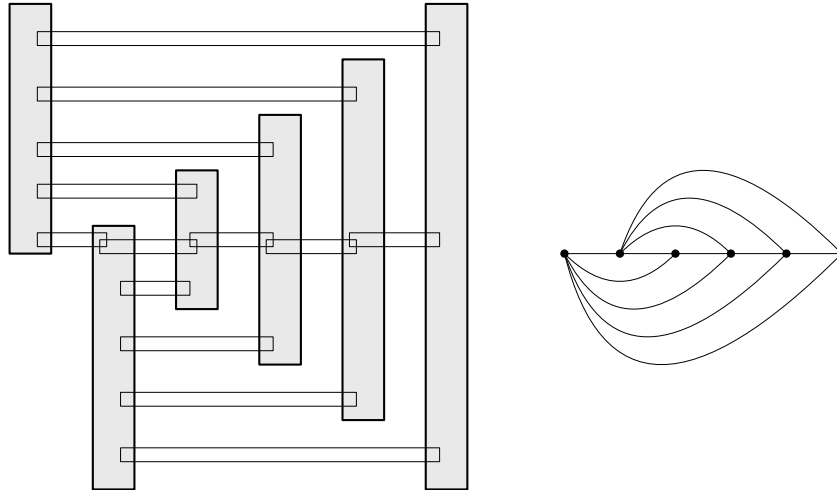

Figure 1.9: On the left, the light gray rectangles represent a packing, and the other rectangles are a set of bridges. On the right, the graph obtained following the construction in the proof of Theorem 1.25

It is not clear if a refinement of this method could decrease the constant in the bound until it matches the one obtained for  $\chi$  and  $\omega$  in Lemma 1.7.

**Question 1.26.** *For a family of axis-parallel squares,  $\tau \leq 4\nu$  holds and can be proved easily by hitting-degeneracy. Does it also hold for cross-free families of axis-parallel rectangles?*

### 1.2.2 Rectangles with a bounded aspect ratio

The first, and apparently last, upper bound  $2(\lceil \rho \rceil + 1)$  for the  $\tau/\nu$  ratio concerning axis-parallel rectangles of aspect ratio at most  $\rho$  has been stated without proof by Ahlswede and Karapetyan [2, Statement 1]. A proof by Chudnovsky, Spirkl, and Zerbib does occur in [23] of a linear bound but with a worse constant.

The techniques developed in Section 1.1.2 enable us to transpose the bounds in Theorem 1.15 from  $\chi$  and  $\omega$  to  $\tau$  and  $\nu$ . This will give a formal proof of the previous result and improve the dependence on  $\rho$  from linear to logarithmic. This result is based on joint work with András Sebő [16].

**Theorem 1.27** (Caoduro and Sebő, 2022). *Let  $\mathcal{R}$  be a family of axis-parallel rectangles in the plane with an aspect ratio of at most  $\rho$ . Then,*

$$\tau(\mathcal{R}) \leq 2(\rho + 1)\nu(\mathcal{R}).$$

Furthermore, if  $\rho \geq 2$ ,

$$\tau(\mathcal{R}) \leq 12 \lceil \log_2 \rho \rceil \nu(\mathcal{R}),$$

improving the linear bound for  $\rho \geq 30$ .

We skip the proof of the theorem because it is entirely analogous to the proof of the corresponding coloring theorem (Theorem 1.15).

Since there is no example providing a  $\tau/\nu$  ratio larger than 2 for axis-parallel rectangles [28, 90], if Wegner's conjecture is proved, these results will become obsolete. Anyway,

Theorem 1.27 still gives us helpful information on the behavior of axis-parallel rectangles. For example, a weaker form of Wegner’s conjecture [49, Problem 4.3] states that the ratio  $\tau/\nu$  is bounded by a constant. The result on rectangles with a bounded aspect ratio implies that a counterexample of this needs to have rectangles with an aspect ratio that grows proportionally with the ratio  $\tau/\nu$ .

Both cross-free rectangles and rectangles with aspect ratios are generalizations of squares. For squares, Theorem 1.27 implies that  $\tau \leq 4\nu - 3$ . Moreover, for unit squares, the multiplicative constant can be improved to two [2, 33], a special case of Wegner’s conjecture. It is unknown whether these two bounds are tight, and, surprisingly, the best-known lower bound is only  $3/2$ , simply achievable with a cycle of five unit squares. The following questions are two of the most frustrating open problems left by this manuscript.

**Question 1.28.** *Is there a family of axis-parallel squares with  $\frac{\tau}{\nu} > \frac{3}{2}$ ?*

**Question 1.29.** *Does Wegner’s conjecture hold for axis-parallel squares?*

### 1.2.3 Extra bounds on $\tau$

In this section, we derive other constant bounds on the ratio  $\tau/\nu$  first using the concept of “critical” families (Theorem 1.32) and then exploiting a connection between the hitting number and the chromatic number (Theorem 1.34). These results help outline open problems on particular families of axis-parallel rectangles where the relationship between  $\tau$  and  $\nu$  is linear, but Wegner’s conjecture, or the optimal multiplicative constant, is not known. We mainly address triangle-free families of axis-parallel rectangles. For this special case, it is easy to show  $\tau \leq 3\nu$ , but we did not manage to reduce the multiplicative constant to 2 (the lower bound given by Theorem 1.23). The hardness of this problem makes us believe that fundamental intuitions about Wegner’s conjecture, or possibly, a counterexample, could be hidden in it.

Given a family  $\mathcal{F}$  of sets, we say that  $\mathcal{F}$  is  $\tau$ -critical if  $\tau(\mathcal{F}) > \tau(\mathcal{F} - F)$  for every  $F \in \mathcal{F}$ , and *connected* if its corresponding intersection graph is connected. Critical families naturally appear when looking at minimal counterexamples on a certain upper bound for the ratio  $\tau/\nu$ .

**Lemma 1.30.** *Let  $\mathcal{F}$  be a family of sets such that  $\tau(\mathcal{F})/\nu(\mathcal{F}) > \tau(\mathcal{F} - F)/\nu(\mathcal{F} - F)$  for any  $F \in \mathcal{F}$ . Then  $\mathcal{F}$  is a  $\tau$ -critical family.*

*Proof.* By contradiction, if  $\mathcal{F}$  is not a  $\tau$ -critical family, then there is a set  $F \in \mathcal{F}$  such that  $\tau(\mathcal{F}) = \tau(\mathcal{F} - F)$ . Clearly,  $\nu(\mathcal{F} - F) \leq \nu(\mathcal{F})$ . Hence,

$$\tau(\mathcal{F} - F)/\nu(\mathcal{F} - F) = \tau(\mathcal{F})/\nu(\mathcal{F} - F) \geq \tau(\mathcal{F})/\nu(\mathcal{F}),$$

a contradiction with the assumption. □

**Lemma 1.31** (Stehlík [85], 2006). *Let  $\mathcal{F}$  be a family of sets. If  $\mathcal{F}$  is connected and  $\tau$ -critical, then  $\tau(\mathcal{F}) \leq \frac{|\mathcal{F}|+1}{2}$ .*

The following theorem shows how to use critical families together with results on  $\nu$  to infer a bound on  $\tau$ . For triangle-free families, Lemma 1.31 can be replaced by Gallai’s lemma (see Section 2.4).

**Theorem 1.32.** *Let  $\mathcal{F}$  be a family of sets. If there is a positive integer  $k$  such that  $\nu(\mathcal{F}') \geq \frac{|\mathcal{F}'|+1}{k}$  for any  $\mathcal{F}' \subseteq \mathcal{F}$ , then  $\tau(\mathcal{F}) \leq \frac{k}{2}\nu(\mathcal{F})$ .*

*Proof.* By contradiction, assume that the statement does not hold and let  $\mathcal{F}' \subseteq \mathcal{F}$  be a counterexample with minimal cardinality. This means that *the property holds for any proper subfamily of  $\mathcal{F}'$* . Hence, for any  $F \in \mathcal{F}'$ ,  $\tau(\mathcal{F}' - F)/\nu(\mathcal{F}' - F) \leq k/2 < \tau(\mathcal{F}')/\nu(\mathcal{F}')$ , implying by Lemma 1.30 that  $\mathcal{F}'$  is  $\tau$ -critical.

Moreover,  $\mathcal{F}'$  has to be connected. Otherwise, it could be partitioned into two non-empty disjoint components  $\mathcal{F}'_1, \mathcal{F}'_2 \subseteq \mathcal{F}'$  such that:

$$\begin{aligned} \tau(\mathcal{F}') &= \tau(\mathcal{F}'_1) + \tau(\mathcal{F}'_2) \\ &\leq \frac{k}{2}\nu(\mathcal{F}'_1) + \frac{k}{2}\nu(\mathcal{F}'_2) = \frac{k}{2}\nu(\mathcal{F}'), \end{aligned}$$

contradicting that  $\mathcal{F}'$  is a counterexample.

Now that we showed that  $\mathcal{F}'$  is  $\tau$ -critical and connected, we can reach the same contradiction again using Lemma 1.31, and the hypothesis on the packing number,

$$\tau(\mathcal{F}') \leq \frac{(|\mathcal{F}'| + 1)}{2} \leq \frac{k}{2}\nu(\mathcal{F}').$$

□

If a graph  $G$  on  $n$  vertices is  $k$ -colorable, then by taking the largest color class we can find a packing of size  $\lceil \frac{n}{k} \rceil$ . For certain values of  $n$  and  $k$ , this is not enough to recover the condition of Theorem 1.32 since the “+1” in the numerator could cause trouble. A similar result can be achieved using a well-known property of bipartite graphs.

**Theorem 1.33.** *If  $G$  is a bipartite graph, then  $\theta(G) = \alpha(G)$ .*

**Theorem 1.34.** *For every family of sets  $\mathcal{F}$  with chromatic number  $\chi(\mathcal{F}) = k$ ,  $\tau(\mathcal{F}) \leq \lceil \frac{k}{2} \rceil \nu(\mathcal{F})$ .*

*Proof.* Assume that  $k$  is even (otherwise add an empty color class without increasing  $\lceil \frac{k}{2} \rceil$ ). The sets in  $\mathcal{F}$  can be partitioned in  $k$  color classes  $\{\mathcal{C}_1, \dots, \mathcal{C}_k\}$ . For any  $1 \leq i \leq \frac{k}{2}$ , the subfamily  $\mathcal{C}_{2i-1} \cup \mathcal{C}_{2i}$  has a bipartite intersection graph. Since bipartite families have the Helly property,  $\tau(\mathcal{C}_{2i-1} \cup \mathcal{C}_{2i}) = \theta(G(\mathcal{C}_{2i-1} \cup \mathcal{C}_{2i}))$ , and by Theorem 1.33,  $\tau(\mathcal{C}_{2i-1} \cup \mathcal{C}_{2i}) = \nu(\mathcal{C}_{2i-1} \cup \mathcal{C}_{2i}) \leq \nu(\mathcal{F})$ . Finally,

$$\tau(\mathcal{F}) \leq \sum_{i=1}^{k/2} \tau(\mathcal{C}_{2i-1} \cup \mathcal{C}_{2i}) \leq \sum_{i=1}^{k/2} \nu(\mathcal{F}) \leq \frac{k}{2}\nu(\mathcal{F}).$$

□

The previous theorems allow us to transform some coloring results into hitting results. First, we look at families with a planar intersection graph. Theorem 1.34, together with the *Four Color Theorem* [4, 5], imply Wegner’s conjecture (if we slightly weaken it by removing the “−1” at the end).

**Corollary 1.35.** *Let  $\mathcal{R}$  be a family of axis-parallel rectangles with a planar intersection graph. Then  $\tau(\mathcal{S}) \leq 2\nu(\mathcal{S})$ .*

□

Then, we can focus on rectangles with a triangle-free intersection graph. Recall that such a family is 6-colorable by Theorem 1.8.

**Corollary 1.36.** *Let  $\mathcal{R}$  be a family of axis-parallel rectangles with a triangle-free intersection graph. Then  $\tau(\mathcal{S}) \leq 3\nu(\mathcal{S})$ .*

□

This time our method gives a multiplicative constant that is larger than the one proposed in Wegner's conjecture. Notice that, for this special case, the value of the optimal multiplicative constant is at least 2 (Theorem 1.23). In the final part of this section, we add further hypotheses to get special cases of Wegner's conjecture, and we propose an almost equivalent problem addressing the packing number of the family.

First, the problem becomes easy if we substitute rectangles with squares (or, more generally, cross-free rectangles).

**Theorem 1.37.** *Let  $\mathcal{S}$  be a triangle-free family of axis-parallel squares. Then  $\tau(\mathcal{S}) \leq \frac{3}{2}\nu(\mathcal{S})$ .*

*Proof.* As a consequence of Lemma 1.10, the intersection graph  $G := G(\mathcal{S})$  is planar. Steinberg and Tovey [86] strengthened Grötzsch theorem by proving that any triangle-free planar graph has a non-uniform 3-coloring. This directly implies that  $\alpha(G) = \nu(\mathcal{S}) \geq \lfloor \frac{n}{3} \rfloor + 1 \geq \frac{n+1}{3}$ . Then, the result follows from Theorem 1.32. □

Another way to obtain a multiplicative constant of 2 is to ask for a stronger condition on the girth of the intersection graph. This allows us to recover the 4-colorability by Theorem 1.13.

**Corollary 1.38.** *Let  $\mathcal{R}$  be a family of axis-parallel rectangles. If the intersection graph of  $\mathcal{R}$  has girth at least 6, then  $\tau(\mathcal{S}) \leq 2\nu(\mathcal{S})$ .*

□

To conclude, we propose a problem that is essentially equivalent to Wegner's conjecture for triangle-free families of axis-parallel rectangles.

**Question 1.39.** *Does  $\nu(\mathcal{R}) \geq \frac{n+2}{4}$  hold for any triangle-free family  $\mathcal{R}$  on  $n$  axis-parallel rectangles?*

If Wegner's conjecture holds, that for any triangle-free family on  $n$  axis-parallel rectangles, we have

$$\nu(\mathcal{R}) \geq \frac{\tau(\mathcal{R}) + 1}{2} \geq \frac{n + 2}{4},$$

where the second inequality holds since  $\tau(\mathcal{R}) \geq \frac{n}{2}$ . In addition, if Question 1.39 has a positive answer, then Theorem 1.32 implies  $\tau(\mathcal{R}) \leq 2\nu(\mathcal{R})$ , for any triangle-free family  $\mathcal{R}$  of axis-parallel rectangles.

Note that  $\nu(\mathcal{R}) \geq \frac{n}{6}$  since triangle-free families of axis-parallel rectangles are 6-colorable (Theorem 1.8) and that there are families on  $n$  rectangles with packing number  $\frac{n}{4} + 2$  (Theorem 1.23).

# Chapter 2

## Axis-parallel segments

In this chapter, we focus on axis-parallel segments, not only an area where general critical aspects of rectangles may emerge more purely but also a relevant topic in its own right that has been considered in several research papers [8, 53, 64]. Chapter 1 does not close the gap between the lower and upper bound of  $\tau/\nu$ , not even for triangle-free axis-parallel rectangles. In the following, we achieve this goal in the special case of axis-parallel segments.

In Section 2.1, we formally introduce the problem and draw some consequences putting our results in the framework of Wegner's conjecture and linking them to a recent breakthrough in the theory of approximation algorithms. Then in Sections 2.2 and 2.3, we give a detailed proof of our two main results: a lower bound on  $\nu$  for axis-parallel segments with a triangle-free intersection graph and the construction showing that this lower bound is essentially tight. Finally, in Section 2.4, we use the former lower bound on  $\nu$  to deduce a new bound on the hitting number of triangle-free axis-parallel segments.

This chapter is the result of joint work with Jana Cslovjecsek, Michał Pilipczuk, and Karol Węgrzycki during the trimester of Discrete Optimization at the Hausdorff Research Institute for Mathematics (HIM) in Bonn, Germany [13].



## 2.1 Introduction

Let  $\mathcal{S}$  be a family of segments in the plane. The parameters  $\tau$  and  $\nu$  are  $\mathcal{NP}$ -hard to compute for families of segments, even if the segments are axis-parallel [36, 65].

The packing number is a trivial lower bound of the hitting number,  $\tau \geq \nu$ . For families of segments lying in at most  $d$  directions, it is also easy to prove a linear upper bound on  $\tau$  using  $\nu$ .

**Proposition 2.1.** *Let  $\mathcal{F}$  be a family of segments in the plane lying in at most  $d$  directions. Then  $\tau(\mathcal{F}) \leq d\nu(\mathcal{F})$ .*

*Proof.* The family  $\mathcal{F}$  can be decomposed into  $d$  subfamilies of parallel segments  $\{\mathcal{F}_1, \dots, \mathcal{F}_d\}$ . For each of these subfamilies  $\nu(\mathcal{F}_i) \leq \nu(\mathcal{F})$  and  $\tau(\mathcal{F}_i) = \nu(\mathcal{F}_i)$  by Theorem 0.11. Hence,  $\tau(\mathcal{F}) \leq \sum_{i=1}^d \tau(\mathcal{F}_i) \leq d\nu(\mathcal{F})$ .  $\square$

This argument gives a bound on the hitting number that could look rough. It is natural to ask if the upper bound can be improved. In this chapter, we study the case  $d = 2$ . Surprisingly, we show that the bound is tight for families of segments lying in at most 2 directions.

**Theorem 2.2.** *For any  $\epsilon > 0$ , there is a family  $\mathcal{M}$  of segments lying in at most 2 directions for which*

$$\frac{\tau(\mathcal{M})}{\nu(\mathcal{M})} \geq 2 - \epsilon.$$

In addition,  $\mathcal{M}$  can be chosen to consist of triangle-free axis-parallel segments, that is, axis-parallel segments with a triangle-free intersection graph. We denote this class by  $\mathcal{G}_{\text{seg}}$ .

We construct a sequence of families in  $\mathcal{G}_{\text{seg}}$  with a ratio  $\tau/\nu$  that approaches 2 as the size of the family grows. More precisely, we prove the following result.

**Theorem 2.3.** *For any integer  $k \geq 1$ , there exists a family  $\mathcal{M}_k$  of axis-parallel segments in  $\mathcal{G}_{\text{seg}}$  with size  $4k^2$ , hitting number  $2k^2$  and packing number*

$$\nu(\mathcal{M}_k) = k^2 + 3k - 2,$$

*that is, its intersection graph  $G$  has  $n$  vertices,  $\theta(G) = \frac{n}{2}$ , and  $\alpha(G) = \frac{n}{4} + \frac{3}{2}\sqrt{n} - 2$ .*

The simple lower bound  $\nu \geq n/\chi$ , where  $n$  is the size of the considered family, is often useful for comparison. Observe that we have  $\chi(\mathcal{S}) \leq 4$  for every  $\mathcal{S} \in \mathcal{G}_{\text{seg}}$  because we can use two colors to properly color the horizontal segments and another two for the vertical segments. Hence, if  $\mathcal{S} \in \mathcal{G}_{\text{seg}}$  has  $n$  segments, then  $\nu(\mathcal{S}) \geq n/4$ . As a side remark, note that for  $n$  large enough,  $n/3 > n/4 + 3\sqrt{n}/2 - 2$ , implying that after a certain  $k$  the family  $\mathcal{M}_k$  is not 3-colorable.

The following result reveals that the lower bound  $\nu(\mathcal{S}) \geq n/4$  can always be improved by an additive term of order  $\sqrt{n}$ .

**Theorem 2.4.** *Let  $\mathcal{S}$  be a family in  $\mathcal{G}_{\text{seg}}$  with  $n$  axis-parallel segments. Then the packing number of  $\mathcal{S}$  is*

$$\nu(\mathcal{S}) \geq \frac{n}{4} + \frac{\sqrt{3}}{12}\sqrt{n}.$$

From Theorems 2.3 and 2.4 follows that the maximum  $\nu_n$  of  $\nu$  on  $n$  axis-parallel rectangles families satisfies  $\nu_n - \frac{n}{4} = \theta(\sqrt{n})$ .

## Consequences

Axis-parallel segments can be seen as degenerate axis-parallel rectangles. Regarding a family of axis-parallel rectangles, there is a long-standing conjecture of Wegner concerning the relation between the hitting number  $\tau$  and the packing number  $\nu$  (Conjecture 1.17).

As we discuss in Chapter 1, the best-known upper bound on the hitting number of a family of axis-parallel rectangles is  $\tau = \mathcal{O}(\nu \log^2 \log \nu)$  [28]. In particular, no linear bounds are known, and only recently a sequence of families with ratio  $\tau/\nu$  arbitrarily close to 2 was found (Theorem 1.23).

Our results have relevant consequences for Wegner's conjecture. On the one hand, Theorem 2.2 implies that *the multiplicative constant of 2 in Wegner's conjecture cannot be improved* even in the highly restricted case of axis-parallel segments, even with the assumption of triangle-freeness. It is worth observing that the class of axis-parallel segments is one of the few sub-classes of axis-parallel rectangles for which Conjecture 1.17 is proved to be asymptotically optimal. Indeed, Wegner's conjecture holds in other subclasses as unit squares [33] and diagonal-touched rectangles [28]. Still, it is not known in any of these cases if the bound in Conjecture 1.17 is optimal or not.

On the other hand, *Wegner's conjecture can be strengthened by an additive term of order  $\sqrt{\nu}$*  for triangle-free families of axis-parallel segments. The analogous improvement cannot be achieved for rectangles in general since there exist families of axis-parallel rectangles with  $\tau = 2\nu - 4$  (Theorem 1.23). This marks a clear difference in the behavior of axis-parallel segments and axis-parallel rectangles.

**Corollary 2.5.** *Let  $\mathcal{S}$  be a family in  $\mathcal{G}_{\text{seg}}$  with  $n$  axis-parallel segments. Then the hitting number of  $\mathcal{S}$  is at most*

$$\tau(\mathcal{S}) \leq 2\nu(\mathcal{S}) - c_3 \sqrt{\nu(\mathcal{S})},$$

for some absolute positive constant  $c_3$ .

The proof of Corollary 2.5 is presented in Section 2.4. As for Theorem 2.4, Theorem 2.3 implies that also Corollary 2.5 is best possible, up to an additive term of order  $\sqrt{\nu}$ .

Theorem 2.2 can be further strengthened to the fractional setting, implying a lower bound on the integrality gap of the standard LP relaxation of the independent set problem. Namely, consider the *fractional independence number* of a graph  $G$ , denoted  $\alpha^*(G)$ , which is defined similarly to  $\alpha(G)$ , but every vertex  $u$  can be included in the solution with a fractional multiplicity  $x_u \in [0, 1]$ , and the constraints are that  $x_u + x_v \leq 1$  for every edge  $uv$  of  $G$ . Similarly, in the *fractional clique covering number*  $\theta^*(G)$  every clique  $K$  in  $G$  can be included in the covering with a fractional multiplicity  $y_K \in [0, 1]$ , and the constraints are that  $\sum_{K: v \in K} y_K \geq 1$  for every vertex  $v$  [84, Section 64.5]. In triangle-free graphs the linear programs defining  $\alpha^*(G)$  and  $\theta^*(G)$  are dual to each other, hence

$$\alpha(G) \leq \alpha^*(G) = \theta^*(G) \leq \theta(G) \quad \text{for every triangle-free } G.$$

Theorem 2.3 has direct consequences in the fractional setting.

**Corollary 2.6.** *For any  $\epsilon > 0$ , there exists a family  $\mathcal{S}$  in  $\mathcal{G}_{\text{seg}}$  having an intersection graph  $G$  such that*

$$\alpha^*(G) \geq (2 - \epsilon)\alpha(G).$$

Consequently, the integrality gap of the standard LP relaxation of the maximum independent set problem is not smaller than 2.

We note that recently, Gálvez, Khan, Mari, Mömke, Pittu, and Wiese gave a polynomial-time  $(2 + \epsilon)$ -approximation algorithm for the maximum independent set problem in intersection graphs of axis-parallel rectangles [41, 42]. Thus, Corollary 2.6 shows that one cannot improve upon the approximation ratio of 2 by only relying on the standard LP relaxation, even in the case of axis-parallel segments. In this case, obtaining a 2-approximation algorithm is very easy: restricting attention to either horizontal or vertical segments reduces the problem to the setting of interval graphs, where it is polynomial-time solvable [47].

## 2.2 Lower bound for $\nu$ : proof of Theorem 2.4

This section aims to prove Theorem 2.4. For this, we examine a family  $\mathcal{S} \in \mathcal{G}_{\text{seg}}$  and exhibit three different families of pairwise disjoint segments. A trade-off between these three families then results in a large packing.

Let  $\mathcal{S} \in \mathcal{G}_{\text{seg}}$ . Our proof starts with a couple of observations on the families of segments we deal with. We may assume that in  $\mathcal{S}$  every two parallel intersecting segments meet at a single point, called the *meeting point*. If two segments do not meet at a single point, we can choose any common point and shorten both segments up to this one. Since no three segments of  $\mathcal{S}$  meet at one point, all intersections are preserved. Further, we may assume that if two orthogonal segments intersect, their intersection point lies in their interiors. Indeed, otherwise, we could slightly extend one or both of these segments around the meeting point. Finally, we may assume that the segments of  $\mathcal{S}$  lie on a grid of size  $\ell_{\text{horiz}} \times \ell_{\text{vert}}$  so that the segments lying on the same grid line induce a path in the intersection graph. Indeed, if the segments induce a disjoint union of several paths on a single grid line, we can move these paths slightly so that they are realized on separate grid lines. A family of segments  $\mathcal{S}$  with the above properties is called *favorable*.

We first need some notation to give constructions for the subfamilies of pairwise disjoint segments in a favorable family  $\mathcal{S}$ . Suppose the  $\ell_{\text{horiz}} \times \ell_{\text{vert}}$  grid has  $\ell_{\text{even}}$  grid lines with an even number of segments and  $\ell_{\text{odd}}$  grid lines with an odd number of segments. In total, there are  $s_{\text{even}}$  segments that lie on a grid line with an even number of segments and  $s_{\text{odd}}$  segments which lie on a grid line with an odd number of segments. Let  $t$  be the maximum number of segments lying on a line.

Each of the following three lemmas corresponds to a different family of pairwise disjoint segments in  $\mathcal{S}$ . In all three lemmas, we assume  $\mathcal{S}$  to be a favorable family in  $\mathcal{G}_{\text{seg}}$  with  $n$  segments.

**Lemma 2.7.** *There exists a subfamily of  $\mathcal{S}$  consisting of  $\frac{n}{4} + \frac{\ell_{\text{odd}}}{4}$  pairwise disjoint segments.*

**Lemma 2.8.** *There exists a subfamily of  $\mathcal{S}$  consisting of  $\frac{n}{4} + \frac{t}{4}$  pairwise disjoint segments.*

**Lemma 2.9.** *There exists a subfamily of  $\mathcal{S}$  consisting of  $\frac{n}{4} + \frac{\sqrt{2s_{\text{even}}}}{4} - \frac{\ell_{\text{odd}}}{4}$  pairwise disjoint segments.*

Before proving these lemmas, we use them to prove Theorem 2.4.

*Proof of Theorem 2.4.* Let  $\mathcal{S}$  be a favorable family in  $\mathcal{G}_{\text{seg}}$ . We distinguish three cases. If  $\ell_{\text{odd}} \geq \sqrt{n}/c$  for some constant  $c$ , by Lemma 2.7  $\mathcal{S}$  has a packing of size at least

$$\frac{n}{4} + \frac{1}{4c}\sqrt{n}.$$

If  $\ell_{\text{odd}} \leq \sqrt{n}/c$  and  $s_{\text{even}} \geq 2n/c^2$ , by Lemma 2.9  $\mathcal{S}$  has a packing of size at least

$$\begin{aligned} \frac{n}{4} + \frac{\sqrt{2s_{\text{even}}}}{4} - \frac{\ell_{\text{odd}}}{4} &\geq \frac{n}{4} + \frac{\sqrt{4n}}{4c} - \frac{\sqrt{n}}{4c} \\ &\geq \frac{n}{4} + \frac{\sqrt{n}}{4c}. \end{aligned}$$

If  $\ell_{\text{odd}} \leq \sqrt{n}/c$  and  $s_{\text{even}} \leq 2n/c^2$ , we get  $s_{\text{odd}} \geq n(1 - 2/c^2)$  using  $s_{\text{even}} + s_{\text{odd}} = n$ . Then the maximum number of segments  $t$  lying on a single line is at least

$$t \geq \frac{s_{\text{odd}}}{\ell_{\text{odd}}} \geq \frac{n(1 - 2/c^2)}{\sqrt{n}/c} = \frac{c^2 - 2}{c} \sqrt{n}.$$

By Lemma 2.8 we get a packing in  $\mathcal{S}$  of size at least

$$\frac{n}{4} + \frac{c^2 - 2}{4c} \sqrt{n}.$$

Setting  $c = \sqrt{3}$  gives the desired result: there is always packing of size at least  $\frac{n}{4} + \frac{1}{4\sqrt{3}}\sqrt{n}$ .  $\square$

It remains to prove the three lemmas.

*Proof of Lemma 2.7.* This construction exploits grid lines with an odd number of segments on them. For each horizontal and vertical grid line, select every second segment lying on that line, starting from the left-most or bottom-most, respectively. If the grid line has an even number of segments, exactly half of the segments are selected. If the grid line has an odd number of segments, the selected number of segments is half rounded up. This corresponds to selecting exactly half of all the segments and adding  $1/2$  for each grid line with an odd number of segments. In total,

$$\frac{n}{2} + \frac{\ell_{\text{odd}}}{2}$$

segments are selected.

By construction of this subset, two segments are only intersecting if one is horizontal and the other one is vertical. The family can be partitioned into horizontal and vertical segments with both parts only containing pairwise disjoint segments, and one of the two parts has at least half of the selected segments.  $\square$

*Proof of Lemma 2.8.* This construction exploits a single grid line with  $t$  segments on it. Let  $g_{\text{horiz}}$  be a horizontal grid line with the maximum number of segments  $t_{\text{horiz}}$  lying on it. Let  $s_{\text{vert}}$  be the total number of vertical segments. Let  $\mathcal{S}_{\text{horiz}}$  be the family consisting of all segments lying on  $g_{\text{horiz}}$  and all vertical segments. Analogously define  $g_{\text{vert}}$ ,  $t_{\text{vert}}$ ,  $s_{\text{horiz}}$ , and  $\mathcal{S}_{\text{vert}}$ . Now we choose the larger family among  $\mathcal{S}_{\text{vert}}$  and  $\mathcal{S}_{\text{horiz}}$ . The size of this family is

$$\begin{aligned} \max\{s_{\text{horiz}} + t_{\text{vert}}, s_{\text{vert}} + t_{\text{horiz}}\} &\geq \frac{s_{\text{horiz}} + t_{\text{vert}} + s_{\text{vert}} + t_{\text{horiz}}}{2} \\ &\geq \frac{n + t}{2} \end{aligned}$$

For the second inequality, we use assertions  $s_{\text{horiz}} + s_{\text{vert}} = n$  and  $t = \max\{t_{\text{horiz}}, t_{\text{vert}}\}$ .

We now observe that the intersection graphs of both families  $S_{\text{vert}}$  and  $S_{\text{horiz}}$  are bipartite. Indeed, any cycle in the intersection graph has to contain at least two horizontal segments lying on two different horizontal grid lines and two vertical segments lying on two different vertical grid lines. But  $S_{\text{vert}}$  contains horizontal segments from only one horizontal grid line, while  $S_{\text{horiz}}$  contains vertical segments from only one vertical grid line. In a bipartite graph, the vertices can be partitioned into two independent sets  $A$  and  $B$ , one of which contains at least half of the vertices. Hence, the larger of the two families  $S_{\text{vert}}$  and  $S_{\text{horiz}}$  contains a packing of size at least  $\frac{n+t}{4}$ .  $\square$

The proof of Lemma 2.9 heavily depends on the following classic theorem of Erdős and Szekeres, here rephrased in the plane setting.

**Theorem 2.10** (Erdős and Szekeres, 1935 [34]). *Given  $n$  distinct points in the plane, ordered by their vertical coordinates, it is always possible to choose at least  $\sqrt{n}$  of them and arrange them into a sequence that is either non-increasing or non-decreasing with respect to the vertical coordinates.*

*Proof of Lemma 2.9.* The construction exploits grid lines with an even number of segments. With the help of Theorem 2.10 we first construct a polyline that cuts through the segments. Then we use this polyline to define two families of pairwise disjoint segments in  $\mathcal{S}$ , one of which has the desired size.

Recall that meeting points are the points in which two parallel segments intersect. A meeting point on a grid line naturally partitions the segments lying on this line into two parts: those to the left of it and to the right of it (for horizontal lines), or those above it and below it (for vertical lines). Call a meeting point a *candidate point* if both these parts have odd cardinalities. Thus, candidate points only occur on grid lines with an even number of segments. In total, there are  $s_{\text{even}}/2$  candidate points.

By Theorem 2.10, there exists either a non-increasing or a non-decreasing sequence of  $\sqrt{s_{\text{even}}/2}$  candidate points. Suppose without loss of generality that the sequence is non-increasing and of maximum possible length. We call *cutting points* the candidate points in the sequence, and we use  $C$  to denote the number of cutting points. Observe that  $C \geq \sqrt{s_{\text{even}}/2}$ . For every two consecutive cutting points, connect them with a segment. Then consider two half-lines with negative inclinations, one ending at the first cutting point and one starting at the last cutting point. This gives a polyline intersecting all vertical and horizontal grid lines. We call this path the *cut*.

Using the cut, we construct two families of segments  $\mathcal{S}_{\text{blue}}$  and  $\mathcal{S}_{\text{orange}}$  (see Figure 2.1).

**Construction of  $\mathcal{S}_{\text{blue}}$ :** The family  $\mathcal{S}_{\text{blue}}$  is constructed as follows. For each vertical grid line, start from the segment with the bottom-most endpoint and choose every second segment with the upper endpoint on the cut or below. Next, for each horizontal grid line, start from the segment with the right-most endpoint and choose every second segment with the left endpoint on the cut or to the right.

**Construction of  $\mathcal{S}_{\text{orange}}$ :** The family  $\mathcal{S}_{\text{orange}}$  is symmetrical to  $\mathcal{S}_{\text{blue}}$ . Namely, for each vertical grid line, start from the segment with the top-most endpoint and choose every second segment with the lower endpoint on the cut or above. For each horizontal grid line, start from the segment with the left-most endpoint and choose every second segment with the right endpoint on the cut or to the left.

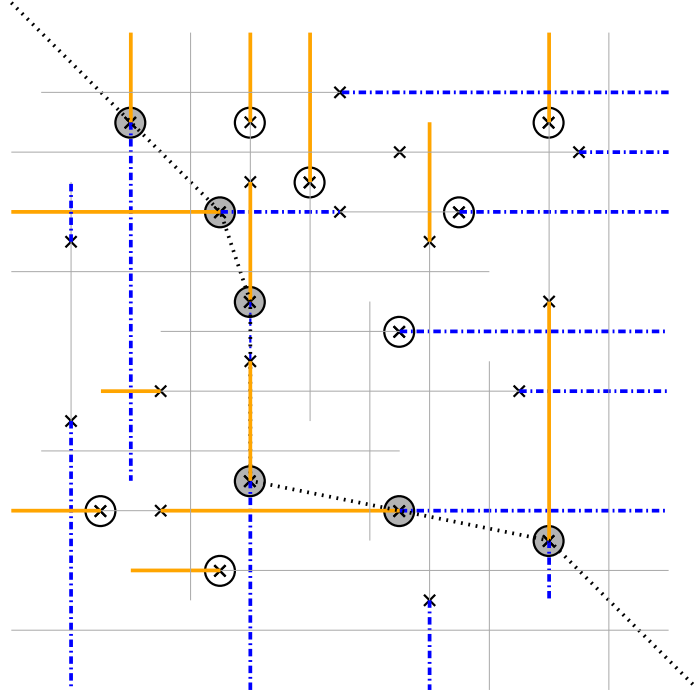

Figure 2.1: Selection of the two pairwise disjoint families in the proof of Lemma 2.9. Crosses are the meeting points, disks are the candidate points, and gray disks are the cut points. The black dotted line is the cut. Dashed blue and solid orange segments are those chosen for the families  $\mathcal{S}_{\text{blue}}$  and  $\mathcal{S}_{\text{orange}}$ , respectively.

If the sequence would be non-decreasing, the choice strategy for horizontal segments would be inverted between  $\mathcal{S}_{\text{blue}}$  and  $\mathcal{S}_{\text{orange}}$ .

We argue that *the segments of  $\mathcal{S}_{\text{blue}}$  are pairwise disjoint*. Note that the segments on the cut's bottom-left side are vertical and pairwise disjoint by the construction, while those on the top-right side of the cut are horizontal and pairwise. So it remains to argue that there is no pair of a vertical segment and a horizontal from  $\mathcal{S}_{\text{blue}}$  that would intersect at a point lying on the cut. Recall that since the representation is favorable, this intersection point would lie in the interiors of both segments. This would imply that either the vertical segment would have the top endpoint strictly above the cut or the horizontal segment would have the left endpoint strictly to the left of the cut. This is a contradiction with the construction of  $\mathcal{S}_{\text{blue}}$ . A symmetric argument shows that also *the segments of  $\mathcal{S}_{\text{orange}}$  are pairwise disjoint*.

It remains to show that  $\mathcal{S}_{\text{blue}} \cup \mathcal{S}_{\text{orange}}$  has at least  $\frac{n}{2} + \frac{\sqrt{2s_{\text{even}}}}{2} - \frac{\ell_{\text{odd}}}{2}$  segments.

Indeed, consider a grid line with an even number of segments. For each candidate point on this line that is not a cutting point, precisely one segment containing this cutting point is in  $\mathcal{S}_{\text{blue}} \cup \mathcal{S}_{\text{orange}}$ . However, for each cutting point on this line, both segments meeting at this point are included in  $\mathcal{S}_{\text{blue}} \cup \mathcal{S}_{\text{orange}}$ , as there is an odd number of segments on either side. This means that on each such grid line, the total number of segments included in  $\mathcal{S}_{\text{blue}} \cup \mathcal{S}_{\text{orange}}$  is precisely half of all the segments, plus one segment for each cutting point on the grid line.

Consider now a grid line with an odd number of segments. The families  $\mathcal{S}_{\text{blue}}$  and  $\mathcal{S}_{\text{orange}}$  contain every second segment starting from the outermost ones. Without the cut, this would include half of the segments lying on the line rounded up. Since there is an odd

number of segments on the grid line, the cut crosses it only at one point. So at most one segment is removed from  $\mathcal{S}_{\text{blue}} \cup \mathcal{S}_{\text{orange}}$  due to this. This means that among the segments lying on the line, at least half rounded down is included in  $\mathcal{S}_{\text{blue}} \cup \mathcal{S}_{\text{orange}}$ . Hence we lose at most  $1/2$  of a segment for each odd grid line.

Together, this gives that  $\mathcal{S}_{\text{blue}} \cup \mathcal{S}_{\text{orange}}$  contains at least

$$\frac{s_{\text{even}}}{2} + C + \frac{s_{\text{odd}}}{2} - \frac{\ell_{\text{odd}}}{2} \geq \frac{n}{2} + \frac{\sqrt{2s_{\text{even}}}}{2} - \frac{\ell_{\text{odd}}}{2}$$

segments. By choosing the larger of the two families, we obtain a packing of the desired size.  $\square$

### 2.3 Extreme examples: proof of Theorem 2.3

In this section, we construct triangle-free families of axis-parallel segments that satisfy the requirements of Theorem 2.3 and with  $\alpha^* = 2k^2$ . Then, Theorem 2.2 and Corollary 2.6 follow by considering  $G = G_k$  for  $k$  large enough depending on  $1/\epsilon$ .

Fix an integer  $k \geq 1$ . We construct a family of  $4k^2$  axis-parallel segments  $\mathcal{M}_k$ . The family  $\mathcal{M}_k$  will consist of  $k$  families of  $4k$  segments each; these families will be called  $k$ -boxes. A  $k$ -box is a family of  $4k$  axis-parallel segments distributed on  $k$  horizontal and  $k$  vertical lines, each with exactly two segments on it. For every line, the two segments on this line intersect at a single meeting point. In the construction of a  $k$ -box, the meeting points are arranged in a diagonal from the top left to the bottom right, see the case  $k = 6$  in Figure 2.2. The *up segments* (resp. *down segments*) of a  $k$ -box are the segments lying vertically above (resp. below) a meeting point. Similarly, we define the *left* and *right segments* of a  $k$ -box.

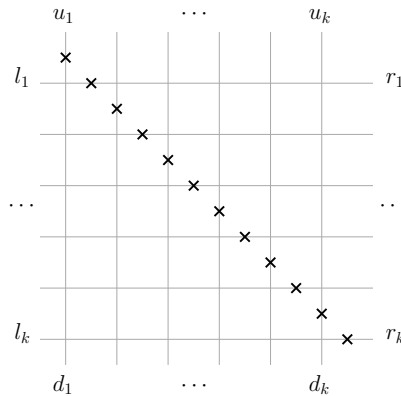

Figure 2.2: A 6-box. Crosses represent the meeting points. Every line contains two segments of the box intersecting only the meeting point on the line.

To construct  $\mathcal{M}_k$ , consider a large square and place  $k$  different  $k$ -boxes  $\{\mathcal{B}_i\}_{i=1}^k$  along its diagonal from the bottom left to the top right. Then, extend each segment away from the meeting point until it touches a side of the square (see Figure 2.3). The construction results in the family  $\mathcal{M}_k$  consisting of  $4k^2$  segments. We note that  $\mathcal{M}_k$  is a favorable family in the sense introduced in Section 2.2. Also, perhaps not surprisingly, the construction is inspired

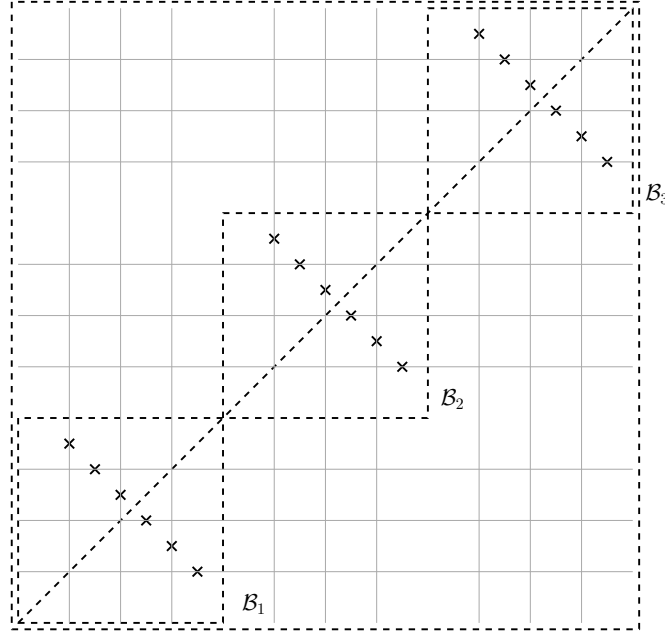

Figure 2.3: The family  $\mathcal{M}_3$ . Crosses represent the meeting points. The dashed lines indicate the sides of the large square and the  $k$ -boxes.

by a tight example for the Erdős-Szekeres Theorem (Theorem 2.10), so that it proves the tightness of the bound provided by Lemma 2.9.

It remains to verify the asserted properties of  $\mathcal{M}_k$ . First, we introduce some notation and definitions. Let  $\mathcal{P}$  be a family of pairwise disjoint segments in  $\mathcal{M}_k$ . A  $k$ -box  $\mathcal{B}_i$  of  $\mathcal{M}_k$  is said to be *interesting* for  $\mathcal{P}$  if  $\mathcal{B}_i \cap \mathcal{P}$  contains either at least one down segment and one right segment, or at least one up segment and one left segment. Otherwise, the  $k$ -box is *boring* for  $\mathcal{P}$ . Distinguishing between interesting and boring boxes allows for more precise estimates of the maximum possible cardinality of  $\mathcal{P}$ .

In the following two lemmas, we consider  $\mathcal{P}$  a family of pairwise disjoint segments in  $\mathcal{M}_k$ .

**Lemma 2.11.** *For any  $k$ -box  $\mathcal{B}$  in  $\mathcal{M}_k$ ,  $|\mathcal{B} \cap \mathcal{P}| \leq 2k$ . Moreover, if  $\mathcal{B}$  is boring for  $\mathcal{P}$ , then  $|\mathcal{B} \cap \mathcal{P}| \leq k + 1$ .*

*Proof.* The first statement holds because  $\mathcal{P}$  contains at most one segment per line, and there are  $2k$  lines in a box:  $k$  vertical and  $k$  horizontal.

Assume that  $\mathcal{B}$  is a boring box for  $\mathcal{P}$ . Enumerate the up and down segments of  $\mathcal{B}$  from left to right as  $U = \{u_1, \dots, u_k\}$  and  $D = \{d_1, \dots, d_k\}$ , and the right and left segments from top to bottom as  $R = \{r_1, \dots, r_k\}$  and  $L = \{l_1, \dots, l_k\}$  (see Figure 2.2). If all segments of  $\mathcal{B} \cap \mathcal{P}$  are pairwise parallel (that is, they are either all vertical or all horizontal), then  $|\mathcal{B} \cap \mathcal{P}| \leq k$  since  $\mathcal{P}$  can contain only one segment per line. Then, two cases are left to check: either  $\mathcal{B}$  contains only up and right segments or only down and left segments. Observe that  $U \cup R$  can be partitioned into  $k + 1$  parts as follows:  $u_1$  and  $r_k$  are in singleton parts, and  $k - 1$  pairs of intersecting segments  $\{u_{i+1}, r_i\}_{i=1}^{k-1}$ . Similarly,  $D \cup L$  can be partitioned into  $k$  pairs of intersecting segments  $\{d_i, l_i\}_{i=1}^k$ . The packing  $\mathcal{P}$  can contain at most one segment from each part of these partitions. Hence,  $|\mathcal{B} \cap \mathcal{P}| \leq k + 1$  in both cases.  $\square$

**Lemma 2.12.** *There are at most two boxes that are interesting for  $\mathcal{P}$ .*



*Proof.* We show that there is at most one interesting box with at least one up and one left segment included in  $\mathcal{P}$ . Then a symmetric argument shows that there is at most one interesting box with at least one down and one right segment included in  $\mathcal{P}$ , implying that there are at most two interesting boxes in total.

Assume for a contradiction that  $\mathcal{M}_k$  has two distinct interesting boxes  $\mathcal{B}, \mathcal{B}'$  of the first kind. Then, either an up segment of  $\mathcal{B} \cap \mathcal{P}$  intersects a left segment of  $\mathcal{B}' \cap \mathcal{P}$ , or vice-versa. This contradicts the fact that segments of  $\mathcal{P}$  are pairwise disjoint.  $\square$

With the lemmas in place, we are in a position to finish the proof of Theorem 2.3. Let  $G_k$  be the intersection graph of  $\mathcal{M}_k$ . By construction, the family  $\mathcal{M}_k$  consists of  $4k^2$  axis-parallel segments and  $\mathcal{M}_k \in \mathcal{G}_{\text{seg}}$ .

First, we compute the clique covering number and the fractional independence number of  $G_k$ . Observe that the  $2k^2$  meeting points of  $\mathcal{M}_k$  form a hitting set, so  $\theta(G_k) = \tau(\mathcal{M}_k) \leq 2k^2$ .

On the other hand, taking every vertex of  $G_k$  with multiplicity  $1/2$  gives a fractional independent set of size  $\frac{|\mathcal{M}_k|}{2} = 2k^2$ , implying that  $\alpha^*(G_k) \geq 2k^2$ . Since  $\theta(H) \geq \alpha^*(H)$  for every triangle-free graph  $H$ , we conclude that

$$\theta(G_k) = \alpha^*(G_k) = 2k^2.$$

It remains to prove that  $\alpha(G_k) = k^2 + 3k - 2$ . We give a family of pairwise disjoint segments in  $\mathcal{M}_k$ , corresponding to an independent set in  $G_k$ . This shows that  $\alpha(G_k) \geq k^2 + 3k - 2$ . The family of segments in  $\mathcal{M}_k$  consists of: (i) the left and up segments of  $\mathcal{B}_1$ , and (ii) the right and down segments of  $\mathcal{B}_2$ , and (iii) the right segments and the top-most up segment of  $B_i$ , for each  $3 \leq i \leq k$ . This is a family of pairwise disjoint segments in  $\mathcal{M}_k$  and it contains  $2(2k) + (k-2)(k+1) = k^2 + 3k - 2$  segments.

To show that  $\alpha(G_k) \leq k^2 + 3k - 2$  we apply Lemma 2.11 and Lemma 2.12 to obtain, for any family  $\mathcal{P}$  of pairwise disjoint segments in  $\mathcal{M}_k$ , that

$$|\mathcal{P}| = |\mathcal{M}_k \cap \mathcal{P}| = \sum_{i=1}^k |\mathcal{B}_i \cap \mathcal{P}| \leq 2(2k) + (k-2)(k+1) = k^2 + 3k - 2.$$

This concludes the proof of Theorem 2.3.

As a final remark, observe in  $\mathcal{M}_k$  every segment has a “free-end” that can be extended without creating any new intersection. Therefore, it is possible to modify the segments appropriately, so they all have the same length. Consequently, the lower bound in Theorem 2.4 cannot be improved under the stronger assumption that the axis-parallel segments have unit length.

## 2.4 Upper bound on the hitting number: proof of Corollary 2.5

In this section, we prove Corollary 2.5 with absolute constant  $c_3 := \frac{c_1}{4} = \frac{\sqrt{3}}{48}$ . Exploiting the properties of factor-critical graphs, this becomes a simple consequence of Theorem 2.4.

For a graph  $G$ , we denote by  $\nu(G)$ , the *maximum matching* in  $G$ , that is, the maximum number of edges in  $G$  without common vertices. Since  $\nu(G)$  corresponds to the packing

number of the family  $E(G)$ , a more coherent notation would be  $\nu(E(G))$ . Still, we choose  $\nu(G)$  since it is simpler. A graph  $G$  on  $n$  vertices is *factor-critical* if  $\nu(G - v) = \frac{n-1}{2}$  for any  $v \in V(G)$ . The following result of Gallai gives a useful characterization of these graphs.

**Lemma 2.13** (Gallai [40], 1963). *A graph  $G$  is factor-critical if and only if  $G$  is connected and  $\nu(G) = \nu(G - v)$  for any  $v \in V(G)$ .*

*Proof of Corollary 2.5.* Assume for a contradiction that Corollary 2.5 does not hold and let  $G$  be the intersection graph of a counterexample with the minimum number of segments. Clearly,  $n := |V(G)| \geq 4$ . First, observe that  $G$  has to be factor-critical. Indeed,  $G$  is connected. Otherwise, it could be separated into two disjoint non-empty components, say  $G_1$  and  $G_2$ . By the minimality of  $G$ ,  $\theta(G_i) \leq 2\alpha(G_i) - c_3\sqrt{\alpha(G_i)}$  for  $i \in \{1, 2\}$ . Hence,

$$\begin{aligned} \theta(G) &= \theta(G_1) + \theta(G_2) \\ &\leq 2(\alpha(G_1) + \alpha(G_2)) - c_3\left(\sqrt{\alpha(G_1)} + \sqrt{\alpha(G_2)}\right) \\ &\leq 2\alpha(G) - c_3\sqrt{\alpha(G)}, \end{aligned}$$

contradicting that  $G$  is a counterexample. Similarly, one can easily check that  $\alpha(G) = \alpha(G - v)$  and  $\theta(G) = \theta(G - v) + 1$  for any  $v \in V(G)$ . Recall that for a triangle-free graph  $H$  on  $k$  vertices,  $k - \theta(H) = \nu(H)$ . Then, the relation between  $\theta(G)$  and  $\theta(G - v)$  gives that  $\nu(G) = \nu(G - v)$ , and Lemma 2.13 implies that  $G$  is factor-critical.

Finally, we have  $\theta(G) = \frac{n+1}{2}$ , and  $\alpha(G) \geq \frac{n}{4} + c_1\sqrt{n}$ , by Theorem 2.4 ( $c_1 = \frac{\sqrt{3}}{12}$ ). Hence,

$$\begin{aligned} \theta(G) &= \frac{n+1}{2} + (2c_1\sqrt{n} - 2c_1\sqrt{n}) \\ &\leq 2\alpha(G) - 2\frac{\sqrt{3}}{12}\sqrt{n} + \frac{1}{2} \\ &\leq 2\alpha(G) - \frac{\sqrt{3}}{48}\sqrt{\alpha(G)}, \end{aligned}$$

where in the last inequality we use that  $n \geq 4$  and  $n \geq \alpha(G)$ . This contradicts that  $G$  is a counterexample, concluding the proof.  $\square$



# Chapter 3

## Squares and rectangles

In this chapter, we provide the first bounds for the  $\tau/\nu$  ratio on not necessarily axis-parallel squares: an upper bound of 6 for unit squares and 10 for squares of varying sizes. The worst ratios we can provide with examples are 3 and 4, respectively. For comparison, in the axis-parallel case, the supremum of the considered ratio is in the interval  $[\frac{3}{2}, 2]$  for unit squares and  $[\frac{3}{2}, 4]$  for arbitrary squares. The new bounds necessitate a mixture of novel and classical techniques of possibly extendable use.

Furthermore, we study rectangles with a bounded aspect ratio. We improved on the best-known  $\tau/\nu$  bound, which was quadratic in terms of the aspect ratio. We reduce it from quadratic to linear for not necessarily axis-parallel rectangles. Finally, we prove similar bounds for the chromatic number of squares and rectangles with a bounded aspect ratio.

The chapter is organized as follows. In Section 3.1, we state our main results and compare them with analogous hitting and packing results for disks and other convex sets. In Section 3.2, we explore the simple and well-known relation between hitting a family of geometric objects and covering a set of points by such a family. This allows pointing at some first bounds on the  $\tau/\nu$  ratio and also at the incompleteness of this method: while an appropriately defined covering is always sufficient for determining a hitting set, it is necessary only in the axis-parallel case. In Section 3.3, we develop our main tools that complete the “covering method”, enabling us to turn some imperfect coverings to be sufficient for constructing smaller hitting sets, enhancing our bounds. In Section 3.4, we complete the geometric setting for efficiently putting together the results of the previous sections and prove the upper and lower bounds for hitting and the upper bound for coloring.

The developed tools can also be applied to families of rectangles with a bounded aspect ratio, where the aspect ratio of a rectangle is the larger side of a rectangle divided by its smaller side. In Section 3.5, we state and prove hitting and coloring theorems for such rectangles. We conclude in Section 3.6 presenting further open questions.

This is joint work with András Sebő [16].

### 3.1 Introduction

Surprisingly, the most natural bounds between packing and hitting numbers are wide open also for some of the simplest geometric objects. In this chapter, we aim to decrease this gap for squares. We bound  $\tau$  from above with a linear function of  $\nu$  and deduce similar bounds for  $\omega$  and  $\chi$  as well. These results are achieved using both classical tools and novel arguments we are presenting here. We also extend the results to a family of *similar convex sets*: two convex sets are called *similar* if they arise from one another by translations, rotations, and homothecies. Clearly, similarity is an equivalence relation, and squares form an equivalence class. Better results can be proved if only translations and rotations are allowed, including the particular case of unit squares. Excluding rotations, we get another specific case that includes axis-parallel squares, for which even better results hold (see Table 3.1).

	<i>convex set</i>	<i>centrally symmetric</i>	<i>disk</i>	<i>square</i>
<i>translation</i>	$\tau \leq 6\nu$ [33]	$\tau \leq 6\nu$ [33]	$\tau \leq 4\nu - 1$ [33]	$\tau \leq 2\nu - 1$ [2]
<i>translation+</i> <i>homothecy</i>	$\tau \leq 16\nu$ [60]	$\tau \leq 7\nu$ [33]	$\tau \leq 7\nu - 3$ [33]	$\tau \leq 4\nu - 3$ [2]
<i>translation+</i> <i>rotation</i>	$\tau \leq 18\rho^2\nu$ Thm. 3.9	$\tau \leq 4\lceil\rho\rceil^2\nu$ Thm. 3.9	$\tau \leq 4\nu - 1$ [33]	$\tau \leq 6\nu$ Thm. 3.2
<i>translation+</i> <i>rotation+</i> <i>homothecy</i>	$\tau \leq 18\rho^2\nu$ Thm. 3.9	$\tau \leq 8\lceil\rho\rceil^2\nu$ Thm. 3.9	$\tau \leq 7\nu - 3$ [33]	$\tau \leq 10\nu$ Thm. 3.2

Table 3.1:  $\tau/\nu$  bounds for a family obtained by translations, rotations, or homothecies of a convex set  $A$ . The *slimness*  $\rho(A)$  of  $A$  is defined here as  $R/r$  where  $R$  is the smallest radius of a disk containing  $A$  and  $r$  is the largest radius of a disk contained in  $A$  (see Section 3.2).

Consider a family  $\mathcal{F}$  of geometric objects. Recall that, a *neighbor* of  $F \in \mathcal{F}$  is simply  $F' \in \mathcal{F}$  such that  $F \cap F' \neq \emptyset$  and the *closed neighborhood*  $N[F]$  of  $F$  consists of  $F$  and all its neighbors, while the *neighborhood* is  $N(F) := N[F] \setminus \{F\}$ . Clearly, deleting  $N[F]$  ( $F \in \mathcal{F}$ ), the maximum size of a packing in  $\mathcal{F}$  decreases by at least one, and the hitting number decreases by at most  $\tau(N[F])$ . Kim, Nakprasit, Pelsmajer, and Skokan [60] exploit this for the translates of a convex body in terms of their “greedy decomposition”. The induction based on bounding  $\tau(N[F])$  is in close analogy with  $k$ -degeneracy for coloring: it will be our main frame for bounding the  $\tau/\nu$  ratio (see Lemma 3.8). It is therefore important to bound  $\tau(N[F])$ , which became the target of the novel geometric methods we worked out, providing the following bounds.

**Lemma 3.1.** *Let  $\mathcal{C}$  be a family of unit squares. The neighbors of any square  $C \in \mathcal{C}$  can be hit by 10 points. Moreover, if the center of  $C$  is left-most among all centers in  $\mathcal{C}$ , 6 points suffice.*

While the induction by degeneracy is a kind of simple greedy framework, this bounding of  $\tau(N[F])$  is a real challenge.

The first part of Lemma 3.1 can be extended to squares of arbitrary size by selecting a square with minimal size and applying homothecy to each of its neighbors (local homothecy, see below), allowing us to conclude.

**Theorem 3.2.** *If  $\mathcal{C}$  is a family of squares,  $\tau(\mathcal{C}) \leq 10\nu(\mathcal{C})$ . Moreover, if the squares have equal sizes,  $\tau(\mathcal{C}) \leq 6\nu(\mathcal{C})$ .*

Finding lower bounds for the ratio  $\tau/\nu$  is also not easy. For families of axis-parallel squares, the only known lower bound is  $3/2$ , achieved by a family of unit squares whose intersection graph is a vertex disjoint union of 5-cycles; no better lower bound is known for squares of different sizes. If arbitrary rotations of the squares are allowed, the  $\tau/\nu$  ratio for unit squares may even be 3, and 4 if squares of different sizes are allowed.

**Theorem 3.3.** *There exists a family of 9 pairwise intersecting unit squares that cannot be hit with less than 3 points. Moreover, there exists a family of 13 pairwise intersecting squares that cannot be hit with less than 4 points.*

Pach [76] proved that for any family  $\mathcal{F}$  of convex sets in the plane,

$$\chi(\mathcal{F}) \leq 9q\Delta(\mathcal{F}),$$

where for each  $F \in \mathcal{F}$  the ratio between the area of the smallest disk  $D(F)$  containing  $F$  (outer disk) and the area of  $F$  is at most  $q \in \mathbb{R}$ . He actually proved  $9q\Delta(\mathcal{F}) - 1$ -degeneracy:

Let  $D(F_0)$  ( $F_0 \in \mathcal{F}$ ) have the smallest radius among  $F \in \mathcal{F}$ , and suppose this radius is 1. We check  $|N(F_0)| \leq 9q\Delta(\mathcal{F}) - 1$ . For each  $F \in N(F_0)$  pick an arbitrary point  $p \in F \cap F_0$  and apply an appropriate homothety with center  $p$  and ratio  $\lambda \leq 1$  – we call this operation *local homothety* –, so that the images of the outer disks (equal to outer disks of the images) are also of radius 1. By convexity,  $F' \subseteq F$ , for all  $F \in N[F_0]$ . Let  $c_0$  be the center of  $D(F_0)$ . Obviously, all these images of outer disks and, therefore, all images  $F'$  ( $F \in N[F_0]$ ) are contained in the disk  $B_2(c_0, 3)$ . Local homothety did not increase the maximum degree of  $\mathcal{F}$ , since  $F' \subseteq F$ , therefore the disk  $B_2(c_0, 3)$  is covered by these images  $F'$ , ( $F \in N[F_0]$ ), at most  $\Delta(\mathcal{F})$  times. The areas of the images  $F'$ , each of which is at least  $1^2\pi/q$  by the definition of  $q$ , sums up to less than  $9\pi\Delta(\mathcal{F})$ :  $|N[F_0]| \leq \frac{9\Delta(\mathcal{F})\pi}{\pi/q} = 9q\Delta(\mathcal{F})$  and  $|N(F_0)| \leq |N[F_0]| - 1$ , as claimed.

If  $\mathcal{C}$  consists of squares, then  $q = \frac{\pi}{2}$ , so Pach's bound is  $\chi(\mathcal{C}) \leq 9\frac{\pi}{2}\Delta(\mathcal{C}) \approx 14.14\Delta(\mathcal{C})$ . This can be essentially improved:

**Theorem 3.4.** *If  $\mathcal{C}$  is a family of squares and  $\Delta(\mathcal{C}) \geq 2$ , then  $\chi(\mathcal{C}) \leq 9(\Delta(\mathcal{C}) - 1)$ . Moreover, if the squares have equal sizes,  $\chi(\mathcal{C}) \leq 6\Delta(\mathcal{C})$ .*

Other results on the chromatic number of families of convex sets can be found in Table 3.2. Note that for any family,  $\Delta \leq \omega$ .

We do not know about nontrivial lower bounds for coloring squares. Since the intersection graph of unit squares may be a  $C_5$ , the chromatic number may be  $\chi = 3$  if  $\omega = 2$ , which is also an upper bound for unit squares with  $\omega = 2$ , because of 2-degeneracy (e.g. [79]). However, the  $3/2$  lower bound cannot be easily kept for higher values of  $\omega$ : the best bound we know about arises by choosing  $\omega$  to be divisible by 4, taking each square of the  $C_5$  example  $\omega/2$  times. In terms of the intersection graph, this is a replication of each vertex  $\omega/2$  times. An optimal coloring is provided then by taking each of the five maximal stable sets of  $C_5$   $\omega/4$  times as color classes, showing  $\chi = \frac{5}{4}\omega$  (e.g. [32]), and this seems to be the best-known example for squares of varying sizes (and not necessarily axis-parallel) as well.

	<i>convex set</i>	<i>centrally symmetric</i>	<i>disk</i>	<i>square</i>
<i>translation</i>	$\chi \leq 3\omega - 2$ [59]	$\chi \leq 3\omega - 2$ [59]	$\chi \leq 3\omega - 2$ [79]	$\chi \leq 2\omega - 1$ [79]
<i>translation+</i> <i>homothecy</i>	$\chi \leq 6\omega - 6$ [59]	$\chi \leq 6\omega - 6$ [59]	$\chi \leq 6\omega - 6$ [59]	$\chi \leq 4\omega - 3$ [2]
<i>translation+</i> <i>rotation</i>	$\chi \leq 9q\Delta$ [76]	$\chi \leq 9q\Delta$ [76]	$\chi \leq 3\omega - 2$ [79]	$\chi \leq 6\Delta$ Thm. 3.4
<i>translation+</i> <i>rotation+</i> <i>homothecy</i>	$\chi \leq 9q\Delta$ [76]	$\chi \leq 9q\Delta$ [76]	$\chi \leq 6\omega - 6$ [59]	$\tau \leq 9(\Delta - 1)$ Thm. 3.4

Table 3.2:  $\chi/\omega$  and  $\chi/\Delta$  bounds for translations, rotations, or homothecies of a convex set.

## 3.2 Relating hitting and covering

In this section, we consider the relation of covering problems to hitting problems for various geometric objects. The two problems are equivalent for axis-parallel unit squares. This equivalence also holds between packing such squares and independent point sets. It is a special case of general statements about unit balls of normed spaces of arbitrary dimension, in particular, or unit boxes of arbitrary dimension (Section 3.2.1).

If we allow arbitrary unit squares (translations and rotations of the unit ball), hitting and covering are no more equivalent: the covering associated with a correct hitting set may have holes! We describe such a situation that will be a powerful tool in the sequel (Section 3.3). Covering with unit squares will also play an important role in hitting squares of arbitrary sizes (Section 3.4). The ideas have then a more general use for handling rectangles (Section 3.5) and convex sets in general (Section 3.2.2).

Supposing an arbitrary norm  $\|\cdot\|$ , recall that for  $x, y \in \mathbb{R}^n$ , the two-variable function  $\|x - y\|$  is a *metric* (that is, a symmetric non-negative function satisfying the “triangle inequality”, and taking the value 0 only for  $x = y$ ); a *ball* is a set of the form

$$B(c, r) := \{x \in \mathbb{R}^n : \|x - c\| \leq r\} \quad (c \in \mathbb{R}^n, r \in \mathbb{R}^+).$$

The point  $c$  is called the *center* of the ball,  $r$  is its *radius*, and  $\mathring{B}(c, r)$  is its *boundary*.

A ball centered at 0 of radius  $r$  is a compact convex set. Moreover it is *centrally symmetric* that is, for  $x \in B$ ,  $-x \in B$ . Conversely, it is also true that any centrally symmetric compact convex set is the unit ball for a norm. For any convex, compact set,  $K - K$  is clearly centrally symmetric, where  $K - L := \{x - y : x \in K, y \in L\}$  ( $K, L \subseteq \mathbb{R}^n$ ).

In our problems will be use mainly the  $l_2$ -norm, also called *Euclidean-norm* and the  $l_\infty$  norm, also called *max-norm*. If there is ambiguity we write the norm we mean in index, in particular,  $\text{dist}_2(x, y) := \|x - y\|_2$ ,  $\text{dist}_\infty(x, y) := \|x - y\|_\infty$ . In two dimensions, balls  $B_2(0, r)$  for the Euclidean norm are *disks* of radius  $r$ , the boundary of a disk is called a *circle*; for the max-norm they are axis-parallel squares of side  $2r$ . Squares  $1 \times 1$ , that is, rotations of balls  $B_\infty(c, 1/2)$  for any  $c \in \mathbb{R}^2$  are called *unit squares*. Sorry for the slight divergence between unit squares and unit balls  $B_\infty(c, 1)$ : the latter are  $2 \times 2$  squares!

Let  $V \subseteq \mathbb{R}^2$  and  $\|\cdot\|$  be a given norm. A *covering* with respect to  $V$  is a set  $\mathcal{B}$  of balls of radius  $\frac{1}{2}$  such that  $V \subseteq \bigcup_{B \in \mathcal{B}} B$ . A subset  $A \subseteq V$  is *independent* if for any pair of different

points  $u, v \in A$ ,  $\|u - v\| > 1$ . The minimum size of a covering, the *covering number*, will be denoted by  $\zeta(V)$ , and the maximum size of an independent subset of points by  $\alpha(V)$ . These definitions are valid for arbitrary norms, and we will mainly use them for the Euclidean norm  $l_2$  or the max-norm  $l_\infty$  by using the indices 2 or  $\infty$ .

Note the distance of any two points  $x, y \in B(c, 1/2)$  is  $\|x - y\| \leq \|x - c\| + \|c - y\| \leq \frac{1}{2} + \frac{1}{2} = 1$ , so  $\alpha \leq \zeta$ . In two dimensions for the max-norm, it follows: *the maximum size of an independent subset of  $V$  is not larger than the minimum cover by axis-parallel unit squares.*

Some further notations will be useful: if  $X$  is a set of points,  $\text{conv}(X)$  denotes their convex hull; if  $X = \{a, b\}$ , we use the shorter notation  $[a, b] := \text{conv}(X)$ . For a square  $C$ ,  $l(C)$  is the length of a side of  $C$ ,  $c(C)$  denotes the center of  $C$ , and given a family of squares  $\mathcal{C}$ ,  $c(\mathcal{C}) := \{c(C) : C \in \mathcal{C}\}$ .

### 3.2.1 The relation

**Proposition 3.5.** *For any norm and family  $\mathcal{B}$  of balls of radius  $\frac{1}{2}$ ,  $\nu(\mathcal{B}) = \alpha(c(\mathcal{B}))$  and  $\tau(\mathcal{B}) = \zeta(c(\mathcal{B}))$ .*

*Proof.* The first equality follows from the fact that  $\mathcal{P} \subseteq \mathcal{B}$  is a packing if and only if for all  $p, q \in c(\mathcal{P})$ ,  $\|p - q\| > 1$ .

For the second equality note that  $H$  is a hitting set of  $\mathcal{B}$ , if and only if for each  $c \in c(\mathcal{B})$  there exists  $h \in H$  such that  $\|c - h\| \leq \frac{1}{2}$ . This means, indeed, exactly that the balls of radius  $\frac{1}{2}$  with centers in  $H$  cover  $c(\mathcal{B})$ .  $\square$

Considering the max-norm and recalling that the balls of radius  $\frac{1}{2}$  are the unit squares for this norm, we obtain the following corollary.

**Corollary 3.6.** *For any family  $\mathcal{C}$  of axis-parallel unit squares,  $\nu(\mathcal{C}) = \alpha_\infty(c(\mathcal{C}))$ ,  $\tau(\mathcal{C}) = \zeta_\infty(c(\mathcal{C}))$ .*

It is easy to see that the axis-parallel unit squares, neighbors of an axis-parallel unit square, can be hit by at most four points (the four corners), and for a left-most unit square by at most two (the two corners on the right side). To illustrate the reformulation of these to the covering number by the second part of Corollary 3.6 we repeat the previous sentence in terms of coverings: *the centers of all possible axis-parallel unit squares intersecting a unit square  $C$  form a square of size  $2 \times 2$  with center  $c(C)$ , hence four unit squares are enough to cover them* (see Figure 3.1). Therefore  $\tau(c(N[C])) = \zeta_\infty(c(N[C])) \leq 4$ . By the ‘‘greedy induction’’ we present in Lemma 3.8,  $\tau \leq 4\nu - 3$  follows for axis-parallel squares of arbitrary size, and  $\tau \leq 2\nu - 1$  for axis-parallel unit squares.

For not necessarily axis-parallel squares Corollary 3.6 is not directly applicable. We make a detour through other norms to still apply the second part of Proposition 3.5 at the price of losing a small constant factor:

The inner disk of a unit square  $C$  is  $B_2(c(C), \frac{1}{2})$  and its outer disk is  $B_2(c(C), \frac{\sqrt{2}}{2})$ . Hitting the inner disks, we also hit the original squares, and packing the outer disks, we also pack the correspondent squares. When arbitrary rotations of any convex body are allowed, the best approximation for  $\tau$  is provided so far by inner balls for the Euclidean norm. For  $\nu$ , we will mainly use the mentioned ‘‘greedy induction’’. Let us illustrate here how the  $\tau$  of the neighbors, serving this greedy induction, can be approximated with the help of the second part of Proposition 3.5. The bound here is slightly weaker than Lemma 3.1, which



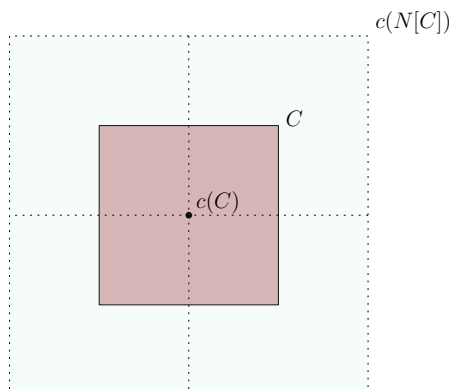

Figure 3.1: An axis-parallel square and the domain of the centers of its neighbors.

will be proved by completing the covering argument used here with the novel methods of Section 3.3.

**Proposition 3.7.** *Let  $\mathcal{C}$  be a family of unit squares and  $C \in \mathcal{C}$ . Then  $\tau(N[C]) \leq 12$ , so  $\tau(\mathcal{C}) \leq 12\nu(\mathcal{C})$ .*

*Proof.* The centers of any unit square intersecting  $C$  are clearly contained in a square  $T$  of size  $\sqrt{2} + 1$ . Replace each  $C' \in \mathcal{C}$  by its inner disk  $B' \subseteq S'$  of radius  $\frac{1}{2}$ , and denote  $\mathcal{B}$  the set of these inner disks. According to Proposition 3.5,  $\tau(N[S]) \leq \tau(\mathcal{B}) = \zeta_2(c(\mathcal{B}))$ , in other words,  $\tau(N[\mathcal{S}])$  can be upper bounded by the minimum number of disks of radius  $\frac{1}{2}$  that cover  $T$ . It is enough to give these disks to prove that 12 such disks are sufficient. Since we will prove the better bound 10 with a more powerful method, we refer to a result of Nurmela and Östergård. In [74], they provide for  $1 \leq n \leq 30$  the minimum  $r_n$  of the equal radii of  $n$  disks that cover a unit square. Then proportionally,  $\frac{1}{2r_n}$  is the maximum side of a square that can be covered by disks of radius  $\frac{1}{2}$ , and  $\frac{1}{2r_{12}} > \sqrt{2} + 1$ .  $\square$

In conclusion, note that hitting and the corresponding covering problem for the centers – while being equivalent for axis-parallel unit squares by Corollary 3.6 – are not equivalent if the squares are not axis-parallel, as Figure 3.2 shows. The centers of the three disks of radius  $\frac{1}{2}$  shown by the figure do hit more unit squares than those whose centers are covered by these disks. All unit squares, even if their center is in the “hole”, as for the represented unit square, are hit. So the triangle can be considered to be a “patch” for the hole between the disks. In Section 3.3 and 3.4, the idea of allowing holes in the cover – and covering them with “patches” is further explored and used to improve the bound offered by Proposition 3.7.

### 3.2.2 General brute force framework

In this section, we show how to apply the tools explained for squares in the introduction to general objects without any specific geometric knowledge about them. Seeing how the covering tool can be used in such a distilled way will help us focus on the more sophisticated geometric arguments in the following sections. At the same time, such a brute force application of the covering tool already shows a constant bound for  $\tau/\nu$  for the translates

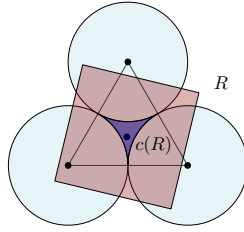

Figure 3.2: A “hole” not covered by any of three disks, but “patched”: the three vertices of the triangle hit all unit squares having their center in the dark hole.

of rotated homothetic copies of a fixed convex set. The rest of the chapter will then enrich this framework with novel geometric arguments to provide essential improvement for squares.

As mentioned in the introduction, the bounds for the minimum hitting sets will use a tool similar to the  $k$ -degeneracy used for coloring graphs. Recall from Section 0.5 that a family  $\mathcal{F}$  of sets is *hitting- $t$ -degenerate* ( $t \in \mathbb{N}$ ) if every  $\mathcal{F}' \subseteq \mathcal{F}$  contains  $F' \in \mathcal{F}'$  with  $\tau(N[F']) \leq t$ . The following lemma was proved in the Introduction (Lemma 0.8).

**Lemma 3.8.** *Let  $\mathcal{F}$  be a hitting- $t$ -degenerate family of sets. Then  $\tau(\mathcal{F}) \leq t\nu(\mathcal{F})$ , moreover if  $\tau \leq t_0$  for families satisfying  $\nu(\mathcal{F}) = 1$ , then  $\tau(\mathcal{F}) \leq t_0 + t(\nu(\mathcal{F}) - 1)$ .*

Surprisingly, neither for the chromatic numbers of intersection graphs of geometric objects versus their maximum degrees nor for bounding their hitting numbers via their packing numbers, nothing is known that would take into consideration the family of objects in a more global way. While hitting-degeneracy used by Lemma 3.8 remains an elementary frame, bounding the parameters  $t$  and  $t_0$  presents real challenges where novel ideas provide relevant improvements.

A convex set  $K$  is said to be *full dimensional* if it contains a ball of positive radius (e.g. in the Euclidean norm, the definition being the same for all equivalent norms). For a full dimensional compact (bounded and close) convex set  $K$ , we can define the *slimness* of  $K$ , denoted by  $\rho_{\|\cdot\|}(K)$ , as the ratio of the radius of the smallest ball containing  $K$  and the largest ball contained in  $K$ . The norm that we will use in various situations depends on the efficiency of the different possibilities. We simplify the notation for the mostly used Euclidean and max norms:  $\rho_2(K)$  denotes the ratio of the radius of the smallest disk containing  $K$  and the largest disk contained in  $K$ ; similarly,  $\rho_\infty(K)$  is the ratio of the sides of the smallest axis-parallel square containing  $K$  and the largest axis-parallel square contained in  $K$ . Observe that  $\rho_2(K)$  is invariant under translations, rotations, and homothety. Moreover,  $\rho_2(K)$  and  $\rho_\infty(K)$  are within a factor of  $\sqrt{2}$  from each other.

For a rectangle  $R$  with sides parallel to the axes,  $\rho_\infty(R)$  is exactly the ratio of the larger side over the smaller side of  $R$ . We call this the *aspect ratio* also for not necessarily axis-parallel rectangles, and denote it  $\rho(R)$  with a slight abuse. This is clearly within a well-controlled constant factor with respect to  $\rho_2(K)$  or  $\rho_\infty(K)$ .

Pach’s coefficient  $q$  is smaller than or equal to  $\rho_{\|\cdot\|}$  since the inner ball is contained in the considered set. The slimness, or for rectangles the closely related aspect ratio, are parameters that have been often used when studying the packing and hitting number (see for example [2] and [19]).

The proof of the following theorem details the repeatedly occurring “local homothety trick” applied here to the  $\tau/\nu$  ratio.

**Theorem 3.9.** *Let  $\mathcal{F}$  be a family of convex sets on the plane of slimness  $\rho_\infty \leq \rho \in \mathbb{R}^+$ . Then*

$$(i) \tau(\mathcal{F}) \leq 9\rho^2 \nu(\mathcal{F}),$$

*Moreover, if the sets are centrally symmetric,*

$$(ii) \tau(\mathcal{F}) \leq 4\lceil \rho \rceil^2 \nu(\mathcal{F}), \text{ and}$$

$$(iii) \tau(\mathcal{F}) \leq 2\lceil \rho \rceil^2 \nu(\mathcal{F}), \text{ if the inner disks are all of the same size.}$$

*Proof.* We proceed by using local homothecies to deduce hitting-degeneracy (as Pach [76] did by degeneracy for the chromatic number, see Section 3.1), and then, applying Lemma 3.8. In this proof, we use the max-norm, so a ball of radius  $r \in \mathbb{R}$  is an axis-parallel square of side length  $2r$ . All the squares in this proof are axis-parallel, so we omit this specification.

Let  $F_0 \in \mathcal{F}$  be a convex set with the smallest inner square and assume for simplicity that the side length of its inner square is 1, and  $F_0 \subseteq B_\infty(c_0, \frac{\rho}{2})$  for a  $c_0 \in \mathbb{R}^2$ .

Apply local homothecies: for any  $F \in N(F_0)$  consider a point  $f \in F_0 \cap F$  and take a homothetic copy  $F'$  of  $F$  containing  $f$ , contained in  $F$ , and with inner square of side length one. Define  $F'_0 := F_0$ . We have that: (a)  $F' \subseteq F$ ; (b)  $f \in F_0 \cap F'$ , in particular,  $F_0 \cap F' \neq \emptyset$ ; and (c) there is a square of side length  $\rho$  containing  $F'$ .

By (a), we can hit the sets in  $N[F_0]$  by hitting  $N' := \{F' : F \in N[F]\}$ , which can be achieved, in turn, by hitting their inner squares. Properties (b) and (c) imply then that all sets in  $N'$ , are contained in  $B_\infty(c_0, \frac{3}{2}\rho)$ , and therefore the centers of these inner squares, all of side length 1, are in  $B_\infty(c_0, \frac{3\rho-1}{2})$  (see Figure 3.3). By Proposition 3.5, then hitting *all possible inner squares* is equivalent to covering the square  $B_\infty(c_0, \frac{3\rho-1}{2})$  by unit squares. Hence,

$$\tau(N[F_0]) \leq \tau(N') \leq \tau(\text{innersquares}(N')) \leq \zeta(B_\infty(p, \frac{3\rho-1}{2})).$$

We immediately get  $\zeta(B_\infty(c_0, \frac{3\rho-1}{2})) \leq \lceil 3\rho-1 \rceil^2 \leq 9\rho^2$ . Applying this to an arbitrary subset of  $\mathcal{F}$ , we see that it is hitting- $9\rho^2$ -degenerate, so (i) follows from Lemma 3.8.

The proof of (ii) follows with the only difference that it exploits the fact that the centers of the inner and outer squares coincide, and the centers of outer squares of sets in  $N'$  are all in  $B_\infty(c_0, \rho)$ , the square of center  $c_0$  and side length  $2\rho$ .

If, in addition, the inner squares of the centrally symmetric sets in  $\mathcal{F}$  all have the same size, local homothecy is not needed anymore, leaving us free to choose  $F_0 \in \mathcal{F}$  to have in addition an inner square with a left-most center. Now the centers of outer squares are contained in one half of  $B_\infty(c_0, \rho)$ , denote it  $M$ . We get  $\tau(N[F_0]) \leq \zeta(M) \leq \lceil \rho \rceil \lceil 2\rho \rceil \leq 2\lceil \rho \rceil^2$ .  $\square$

To bound the hitting number of translates of rotated homothetic copies of a fixed convex set  $K$ , it is unfortunately not sufficient to substitute its slimness to Theorem 3.9, since  $\rho_\infty$  is not invariant under rotation. However,  $\rho_2$  is, and using this, the theorem can be applied. Since  $\rho_\infty(K) \leq \sqrt{2}\rho_2(K)$ , this only adds a factor of 2 in the bounds (see Table 3.1).

These estimates are, of course, rough but do satisfy the modest goal of showing how local homothecy applies to handling slimness and how to take advantage of particularities like central symmetry for sharpening the results. We will be less generous and care about getting the best bound we can for squares and unit squares.

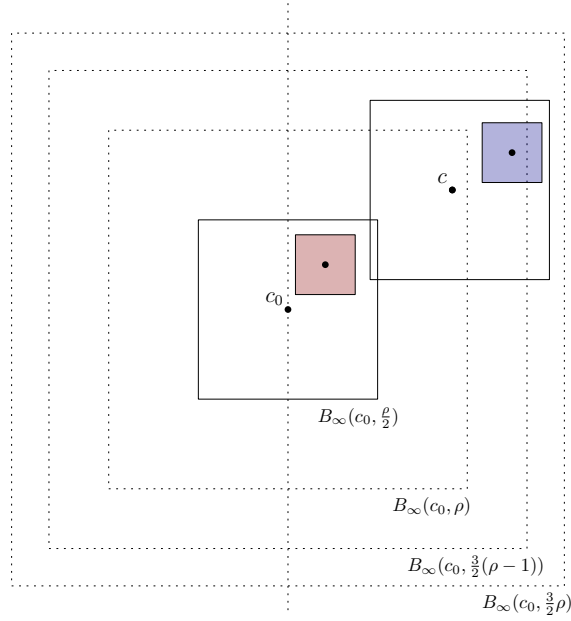

Figure 3.3: The outer and inner squares of two intersecting convex sets with slimness  $\rho_\infty \leq \rho$  and inner unit squares. In red, the inner square of  $F_0$  and in blue, the one of  $F$ .

### 3.3 Filling holes

In this section, we find “patches” for “holes” left out by coverings. A first kind of hole, shown by Figure 3.2, is discussed and patched in Section 3.3.1. Section 3.3.2 further develops this technique by finding another set of covering objects for points outside a convex hull by Thales’ celebrated theorem. Finally, Section 3.3.3 completes the picture by showing one more “patch” for filling holes.

The covering balls, completed by these three kinds of patches, reformulate the hitting versus packing bound with an enhanced covering tool that is used in Section 3.4 for proving the main results of this chapter.

#### 3.3.1 Filling holes inside triangles

First, let us formalize the intuition coming from Figure 3.2.

**Lemma 3.10.** *Let  $a, b, c$  be three points in the plane,  $\text{dist}_2(a, b) \leq 1$ ,  $\text{dist}_2(b, c) \leq 1$ , and  $\text{dist}_2(a, c) \leq 1$ . Then any square  $C$  of sides at least 1 and center  $c(C) \in T := \text{conv}(\{a, b, c\})$  contains either  $a, b$ , or  $c$ .*

*Proof.* By the condition,  $c(C) \in K := T \cap C$ . We prove that *the polygon  $K$  has a vertex which is a vertex of  $T$ .*

Suppose for a contradiction that this is not true. Then the vertices of  $K$  are vertices of  $C$  or intersections of a side of  $C$  and a side of  $T$ , so *the vertices of  $K$  lie on the sides of  $C$ , and all of them lie on two intersecting sides  $[x, y], [y, z]$  of  $C$  since the distance of any pair of vertices on two distinct parallel sides of  $C$  is at least 1, while the distance of points of  $T \setminus \{a, b, c\}$  it is smaller than 1.*

However, among the convex hulls of pairs of points in  $[x, y] \cup [y, z]$ , only  $[x, z]$  contains  $c(C)$ . Since  $c(C) \in K$ , we have  $x, z \in K \subseteq T$ . But  $\text{dist}_2(x, z) > 1$ , a contradiction.  $\square$

### 3.3.2 Filling holes outside separating lines

The equivalence of the following statements is an immediate consequence of Thales's theorem or its converse.

**Proposition 3.11.** *Let  $a, b$  be two points on a line  $L \subseteq \mathbb{R}^2$  and  $q$  the middle point of the segment  $[a, b]$ . The following statements are equivalent for a point  $c$  of the plane:*

- (i) *The point  $c$  forms a non-degenerate triangle with  $a$  and  $b$ , and  $\text{dist}_2(c, q) < \text{dist}_2(q, a) (= \text{dist}_2(q, b) = \text{dist}_2(a, b)/2)$ .*
- (ii) *The point  $c$  is in one of the two open half-disks determined by the intersection of the inside of the circle with center  $q$ , radius  $qa$ , and the line  $L$ .*
- (iii) *There exists a right-angled triangle with a proper subsegment of  $[a, b]$  as hypotenuse and  $c$  as third vertex.*
- (iv) *There exists a right-angled triangle with a proper subsegment of  $[a, b]$  symmetric to  $q$  as hypotenuse and  $c$  as third vertex.*
- (v) *The angle  $acb$  satisfies  $\pi/2 < acb < \pi$ , (that is, it is an obtuse angle).*

We need here mainly the equivalence of (i) with (iv), the others are just reformulations for occasional comfort, the right picture, or possible future use.

*Proof.* Statements (i) and (ii) just phrase the same fact slightly differently. Then (i) or (ii) obviously imply all the others by Thales, and the others imply (i) and (ii) by the converse of Thales.  $\square$

We say that a line *separates* two sets if these sets are in two different open half-planes bordered by the line. The following lemma is still essentially Thales's theorem, reformulating and completing the equivalence of (i) and (iii) to a form that will be comfortable to use for hitting sets.

**Lemma 3.12.** *Let  $a, b$  be two points on a line  $L \subseteq \mathbb{R}^2$ ,  $\text{dist}(a, b) \leq 1$ ,  $q$  the middle point of the segment  $[a, b]$ , and  $c \in \mathbb{R}^2 \setminus L$ . Then  $\text{dist}_2(q, c) \geq \text{dist}_2(q, a)$  if and only if each unit square  $S$ ,  $c \in S$  so that  $L$  separates  $c(S)$  from  $c$ , and  $S \cap [a, b] \neq \emptyset$  contains either  $a$  or  $b$ .*

*Proof.* We prove  $\text{dist}_2(q, c) < \text{dist}_2(q, a)$  if and only if there exists a unit square  $S$  whose center is separated from  $c$  by  $L$ , and  $a, b \notin S$ .

First, suppose  $\text{dist}_2(q, c) < \text{dist}_2(q, a)$ . Then there exist two points  $a', b'$  on the subsegment  $[a', b']$  of the segment  $[a, b]$ , symmetric to  $q$ , so that  $\text{dist}_2(a', b') = \text{dist}_2(q, c) < \text{dist}_2(q, a)$ . The circle of center  $q$ , diameter  $[a', b']$  contains  $c$ , so by Thales's theorem,  $a'b'c$  is a triangle with a right angle at  $c$ . Since the hypotenuse of the triangle has length  $\text{dist}_2(a', b') < \text{dist}_2(a, b) \leq 1$  we also have that the sides  $a'c$  and  $b'c$  are of length less than 1. Therefore, this triangle can be completed to a unit square intersecting  $[a, b]$ , containing  $c$ , but avoiding  $a$  and  $b$ , and its center is separated from  $c$  by  $L$ .

Conversely, assume there exists a unit square  $S$  whose center is separated from  $c$  by  $L$ , which meets  $[a, b]$  and contains  $c$ , but neither  $a$ , nor  $b$ . By the separation and the convexity of  $S$ ,  $S \cap [a, b]$  is a non-empty proper subsegment of  $[a, b]$ , and since  $\text{dist}_2(a, b) \leq 1$ , no

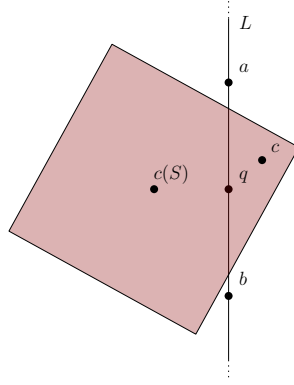

Figure 3.4: A feasible input for Lemma 3.12

two parallel sides of  $S$  can meet  $[a, b]$ . Therefore, the half-plane containing  $c$  intersects  $S$  in a right-angled triangle  $a'b'c'$ , with hypotenuse  $[a', b'] \subset [a, b]$ , and right angle in  $c'$ . Clearly,  $\text{dist}_2(q, c) \leq \text{dist}_2(q, c')$ , and  $\text{dist}_2(q, c') < \text{dist}_2(q, a)$  applying Proposition 3.11 “(iii) implies (i)” to the point  $c'$  and the triangle  $a'b'c'$ .  $\square$

### 3.3.3 Patch using the triangle inequality

The following lemma strengthens Lemma 3.12. It is used in some situations to fill in the holes left by previous covers and patches.

**Lemma 3.13.** *Let  $a, b \in \mathbb{R}^2$ ,  $\text{dist}_2(a, b) \leq 1$ ,  $q$  the middle point of the segment  $[a, b]$ , and  $d := \text{dist}_2(q, a)$ . Then any square of side at least 1 with center in  $B_2(q, \frac{\sqrt{2}}{2} - d)$  contains either  $a$  or  $b$ .*

*Proof.* Let  $L$  be the line containing  $[a, b]$  and, for a contradiction, let  $S$  be a unit square  $S$  with center in  $B_2(q, \frac{\sqrt{2}}{2} - d)$  that meets  $[a, b]$ , but contains neither  $a$ , nor  $b$ . By the convexity of  $S$ ,  $S \cap [a, b]$  is a segment  $[a', b']$  and since  $\text{dist}_2(a', b') < 1$ , no two parallel sides of  $S$  can meet  $[a, b]$ . Therefore, two incident sides of  $S$  meet  $L$ , let  $c$  be the vertex of  $S$  where they intersect. The half-plane defined by  $L$  and containing  $c$  intersects  $S$  in a right-angled triangle  $a'b'c$ , with  $a', b' \in [a, b]$ , and the right angle in  $c$ . Applying Proposition 3.11 “(iii) implies (i)”,  $\text{dist}_2(q, c) < \text{dist}_2(q, a) = d$ . Consider the triangle defined by  $c(S)$ ,  $q$  and  $c$  (Figure 3.5(a)), by the triangle inequality, we have

$$\frac{\sqrt{2}}{2} = \text{dist}_2(c(S), c) \leq \text{dist}_2(c(S), q) + \text{dist}_2(q, c) < \left( \frac{\sqrt{2}}{2} - d \right) + d = \frac{\sqrt{2}}{2}.$$

This contradiction concludes the proof of the lemma.  $\square$

## 3.4 Deducing the new bounds for squares

In Section 3.2 and Section 3.3, we developed the main tools for proving our results. In this section, we first complete these by deducing simple consequences (Section 3.4.1). Then, in Section 3.4.2, we provide the proofs of our hitting and coloring results: Theorems 3.2, 3.3, and 3.4.

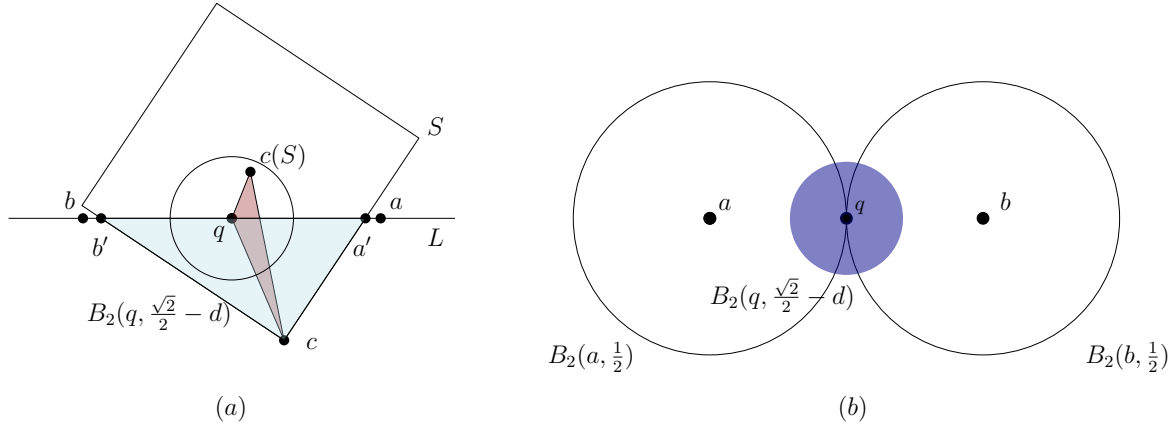

Figure 3.5: Figure (a) illustrates the setup of Lemma 3.13, while Figure (b) shows the additional “patch” that is obtained.

### 3.4.1 Completing the tools

We get an efficient tool for proving stronger  $\tau/\nu$  bounds by combining Lemma 3.10 and Lemma 3.12: a sufficient condition follows then for hitting each unit square that contains a point inside a convex polygon, far enough from its vertices. We state this tool in a theorem that can then be used for any compact set inside the polygon distant enough from the vertices:

**Theorem 3.14.** *Let  $\{p_1, \dots, p_k\} \subset \mathbb{R}^2$  be a set of points in convex position,  $P := \text{conv}(p_1, \dots, p_k)$ ,  $p_{k+1} := p_1$ , and denote by  $q_i$  the middle point of the side  $[p_i, p_{i+1}]$  of  $P$ . Moreover, let  $p_0 \in P$ ,  $C \subseteq P$  a closed set, and assume*

- (i)  $\text{dist}_2(p_0, p_i) \leq 1$  for any  $1 \leq i \leq k$ ;
- (ii)  $\text{dist}_2(p_i, p_{i+1}) \leq 1$  for any  $1 \leq i \leq k$ ;
- (iii)  $\text{dist}_2(p_i, q_i) \leq \text{dist}_2(q_i, C)$  for each  $1 \leq i \leq k$ .

*Then a unit square  $S$ ,  $S \cap C \neq \emptyset$  is hit by at least one of the points in  $\{p_0, p_1, \dots, p_k\}$ . Furthermore, if (iii) holds only for  $i \in I$ ,  $I \subseteq \{1, \dots, k\}$ , then the assertion still holds in addition  $c(S)$  is on the same side of the line  $L_i \supset [p_i, p_{i+1}]$  as  $C$ , for all  $i \in \{1, \dots, k\} \setminus I$ .*

*Proof.* We only prove the more general additional statement, then the main assertion follows with the choice  $I = \{1, \dots, k\}$ .

First, suppose  $c(S) \in P$ . Let  $T_i := \text{conv}(p_0, p_i, p_{i+1})$  ( $1 \leq i \leq k$ ), and note  $P = \cup_{i=1}^k T_i$ . Therefore there exists  $i \in \{1, \dots, k\}$ , such that  $c(S) \in T_i$ , and by the conditions (i) and (ii) we can apply Lemma 3.10 to  $T_i$ . Applying it, we get that  $a := p_0$ ,  $b := p_i$  or  $c := p_{i+1}$  do hit  $T_i$ .

Second, assume  $c(S) \notin P$ , and let  $c \in S \cap C$ . Since  $c \in P$ , there exists a side of the polytope  $P$ , say  $[p_i, p_{i+1}]$  whose line  $L_i$  separates  $c(S)$  and  $c$ . Then  $i \in I$ , since otherwise, by the condition,  $c(S)$  and  $c$  cannot be separated by  $L_i$ . Now according to (iii) the condition of Lemma 3.12 is satisfied for  $c$ ,  $a := p_i$ ,  $b := p_{i+1}$ , and therefore either  $p_i$  or  $p_{i+1}$  hits  $S$ .  $\square$

Let  $R$  and  $S$  be two squares. Recall that  $R$  and  $S$  are *crossing*, or have a *cross intersection*, if  $R \cap S$  is non-empty but contains none of the eight vertices of the two squares. Otherwise,  $R$  and  $S$  have a *corner intersection*. The following lemma will be useful for coloring squares:

**Lemma 3.15.** *Given two crossing squares, each of them contains the center of the other.*

*Proof.* Let  $R$  and  $S$  be two crossing squares,  $p \in R \cap S$ , and suppose for a contradiction that  $c := c(S) \notin R$ . Then the segment  $[p, c]$  crosses the boundary of  $R$  in a side of  $R$ , let  $[u, v]$  be this side, where  $u$  and  $v$  are vertices of  $R$ , and  $L$  the line that contains  $[u, v]$ . Since  $S$  contains neither  $u$  nor  $v$ ,  $\emptyset \neq L \cap S$  is a proper subset of  $[u, v]$ , denote its endpoints by  $u'$  and  $v'$ .

We distinguish two cases:

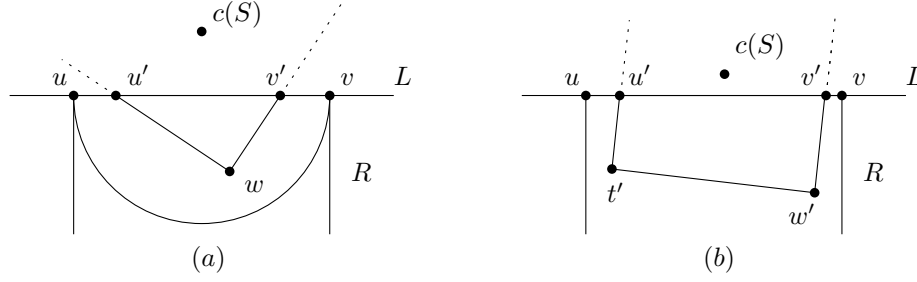

Figure 3.6: The two kinds of crossing intersections.

**Case a:** *The segment  $[u', v']$  joins two intersecting sides of  $S$  (see Figure 3.6 (a)).*

Then  $S \cap R$  is a right-angled triangle  $u'v'w$ , where  $w$  is a vertex of  $S$ . By Proposition 3.11 “(iii) implies (ii)” applied to  $a = u$ ,  $b = v$ ,  $c = w$ ,  $w$  lies in the open half-disk with diameter  $[u, v]$ . However, this half-disk is fully contained in  $R$ , and contains the vertex  $w$  of  $S$ , contradicting that  $R$  and  $S$  are crossing.

**Case b:** *The segment  $[u', v']$  joins two parallel sides of  $S$  (see Figure 3.6 (b)).*

Then  $L$  separates  $c$  and two vertices  $t'$  and  $w'$  of  $S$ , assume that  $t'$  lies on the same side of  $S$  as  $u'$ , and  $w'$  on the same side as  $v'$ . Both  $t'$  and  $w'$  are in the same half-plane limited by  $L$ , as  $R$ , and also in the same half-plane as  $R$  limited by the side  $L'$  parallel to  $L$ , since otherwise  $\text{dist}_2(u', t') \geq l(R)$  or  $\text{dist}_2(v', w') \geq l(R)$  respectively, contradicting  $l(S) \leq \text{dist}_2(u', v') < l(R)$ .

Furthermore, at least one of two vertices  $t'$  and  $w'$  of  $S$  must also be in the intersection of the half-spaces limited by the two parallel sides of  $R$  perpendicular to  $L$ , containing  $R$ . Then  $t'$  or  $w'$  is in  $R$ , contradicting that  $R$  and  $S$  are crossing. Indeed, if  $t'$  and  $w'$  are in different half-spaces not containing  $R$  then  $\text{dist}_2(t', w') = l(S) > l(R)$ , which is the same contradiction again; or if they are in the same half-space not containing  $R$  then either  $\text{dist}_2(u', t')$  or  $\text{dist}_2(v', w')$  would be larger than  $\text{dist}_2(u', v') \geq l(S)$ .  $\square$

### 3.4.2 Hitting Squares

In this section, we first prove the promised upper bound on the hitting number: Lemma 3.1 leading to Theorem 3.2. Then we proceed with the proof of the lower bound stated in Theorem 3.3.

**Proof of Lemma 3.1.** Let  $C$  be an arbitrary unit square in  $\mathbb{R}^2$ , and suppose that the origin is in  $c(C)$  and the axes are parallel to the sides of  $C$ . We want to present 10 points and apply Theorem 3.14 to show that they hit all possible neighbors of  $C$ . For satisfying conditions (i) and (ii) we first find a set of 9 points on the circle  $\mathring{B}_2(p_0, 1)$  of center  $p_0 := c(C)$  and



radius 1. As a first trial, we can choose these to form a regular 9-gon. However, the relation of a regular 9-gon to  $C$  is not regular. To satisfy condition (iii), slight modifications of the 9-gon are necessary:

Since the sides of  $P$  are significantly smaller than 1, we have a margin to move the vertices of  $P$  while preserving condition (ii), performing the following task: move two neighboring vertices closer together when their mid-point  $q$  is too close to  $C$  to satisfy (iii), happening when the closest point of  $C$  is a vertex of  $P$ , while it can be afforded to move the two vertices of a side away from one another when the mid-point  $q$  of the side is relatively far from  $C$ . The margin is sufficiently large to easily get points satisfying (iii) without worrying about rounding errors.

The coordinates of the points we found are given in Figure 3.7. They clearly satisfy (i) and (ii) without computation, and for checking (iii), it is sufficient to check the distances from the vertices and the sides of  $C$ . Hence, by Theorem 3.14, for any possible unit square  $S$  intersecting  $C$ , we get that  $S$  is hit by at least one of the points in  $\{p_0, p_1, \dots, p_9\}$ .

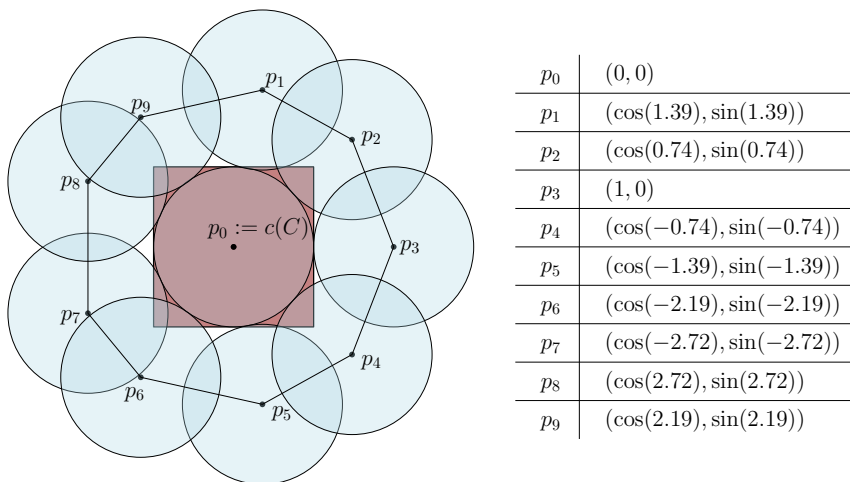

Figure 3.7: A unit square and the 10 points hitting its neighbors.

To prove the second part of the Lemma, suppose the squares of the family  $\mathcal{C}$  (consisting of unit squares) are given in  $\mathbb{R}^2$ , and that the origin is the left-most center of a square, denote  $C$  such a square,  $O = c(C)$ . The sides of  $C$  are not necessarily parallel to the axes, causing complications.

However, by choice of  $C$ , no squares have their center to the left of the vertical axis. We also know that the centers of the neighbors we want to hit are in the disk  $B_2(O, \sqrt{2})$ :

**Claim 1.** *All centers of squares in  $N[C]$  are in the half-disk  $Q := \{(x, y) \in B_2(O, \sqrt{2}) : x \geq 0\}$ .*

Unfortunately, we cannot immediately rely on some half of the 10 hitting points of the first part of the proof, for instance, arguing that the right part of Figure 3.7, that is, hitting points  $p_0, \dots, p_5$  suffice, because some squares having their centers in  $Q$  may have had their unique hitting point on the left. Moreover, we must remember that the sides of  $C$  cannot be supposed now to be parallel to the axes.

Let  $v$  be the vertex of  $C$  in the non-negative quadrant. We call the angle of  $Ov$  with the horizontal axis, the *angle* of  $C$ , and denote it  $\angle(C)$ . The range of angles to be considered is  $0 \leq \angle(C) \leq \pi/2$ . For instance if  $C$  is axis-parallel,  $\angle(C) = \pi/4$ .

We will keep looking for five of our hitting points to be on  $\overset{\circ}{B}_2(p_0, 1)$ , but instead of  $p_0 = c(C)$  it is better now to have  $p_0 := (t, 0)$  for  $t \in \mathbb{R}^+$  that we will choose later. Then in view of Theorem 3.14 we search the five other hitting points on  $\overset{\circ}{B}_2(p_0, 1)$ . We fix  $p_0 := (t, 0)$ ,  $p_1 := (t, 1)$ ,  $p_3 := (t + 1, 0)$ ,  $p_5 := (t, -1)$ , parameterized by  $t$ . Figure 3.8 shows the introduced hitting points, with a tentative choice for  $p_2$  and  $p_4$  that will need a more refined definition depending on  $C$ . The figure includes some circles and disks that play a role. In the spirit of Proposition 3.5 it is important that unit squares having their center in  $\cup_{i=0}^5 B_2(p_i, \frac{1}{2})$  are hit by  $\{p_0, \dots, p_5\}$ . It remains to work for hitting squares not having their center in these disks. There are two difficulties to overcome for covering the “holes” (white zones) of  $Q$ , that is, those, not covered by  $\cup_{i=0}^5 B_2(p_i, \frac{1}{2})$ :

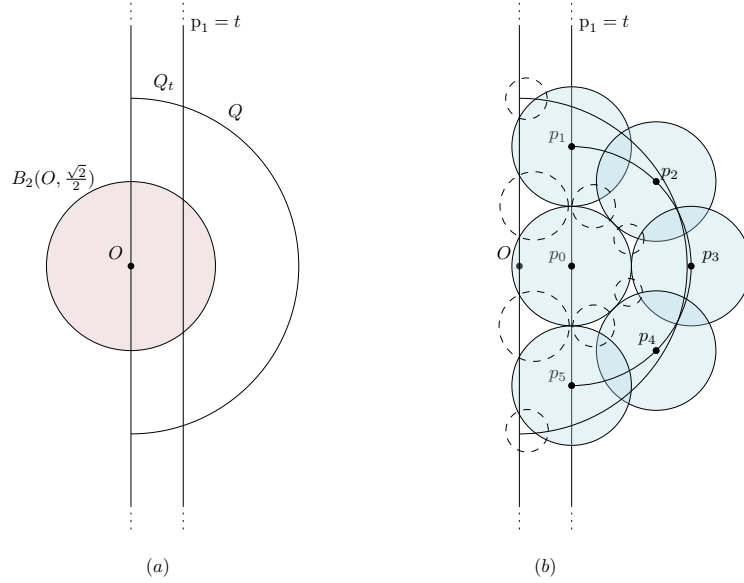

Figure 3.8: (a) The half-disk  $Q$ , the “strip”  $Q_t$ , and the disk  $B_2(O, \frac{\sqrt{2}}{2})$  swept by all possible  $C$ .

(b) The planned 6 hitting points with the disks of all centers of unit squares they surely hit.

First, we have to cover the white holes of  $Q_t := Q \cap \{(x, y) : 0 \leq x \leq t\}$ , that is points not covered by  $\cup_{i=0}^5 B_2(p_i, \frac{1}{2})$ . The larger  $t$  is, the larger the holes are at four possible places of  $Q_t$  (see Figure 3.8 (b)). If  $t$  is small, two of these disappear, and Lemma 3.13 provides sufficient “patches” for the other two and also for computing the maximum of  $t$  for which this is possible (Claim 2).

Second, for the centers in  $Q \cap \{(x, y) : x \geq t\}$ , if the  $t$  value is too small, no matter how we fix three more points on the boundary of the half-disk  $Q$ , they will not suffice for satisfying condition (iii) of Theorem 3.14 for all possible  $C$ . We will see, though, that for the maximum value of  $t$  computed in Claim 2, one out of two choices of sets of size 6 will always be hitting, depending on  $\angle(C)$  (Claim 3).

**Claim 2.** *If  $t = \frac{\sqrt{4\sqrt{2}-5}}{4}$ , then  $S \cap \{p_0, p_1, p_5\} \neq \emptyset$  for any unit square  $S$ ,  $c(S) \in Q_t$ .*

Since unit squares contain a disk of radius  $\frac{1}{2}$ , this is true if  $c(S) \in B_2(p_0, \frac{1}{2}) \cup B_2(p_1, \frac{1}{2}) \cup B_2(p_5, \frac{1}{2})$ . Apply now Lemma 3.13 with  $a = p_0$ ,  $b = p_1$ , and consequently  $d = \frac{1}{2}$ , to conclude that any unit square with center in  $B_2(q, \frac{\sqrt{2}-1}{2})$  contains either  $p_0$  or  $p_1$ , where  $q$

is the middle point of the segment  $[p_0, p_1]$ . Therefore, if the intersection point of  $B_2(p_0, \frac{1}{2})$  with the vertical axis is contained in  $B_2(q, \frac{\sqrt{2}-1}{2})$ , then by obvious symmetries, we get that either  $\{p_0, p_1\}$  or  $\{p_0, p_5\}$  meet every square  $S$  with  $c(S) \in Q_t$ , provided that the following two conditions are satisfied:

$$t^2 + \left(\frac{1}{2} - \sqrt{\frac{1}{4} - t^2}\right)^2 \leq \left(\frac{\sqrt{2}-1}{2}\right)^2; \quad \text{dist}_2(p_1, (0, \sqrt{2}))^2 = t^2 + (\sqrt{2}-1)^2 \leq \frac{1}{4}.$$

The maximum of  $t$  under the first condition is  $\frac{\sqrt{4\sqrt{2}-5}}{4}$ , and for this value, the second condition is also satisfied, finishing the proof of Claim 2.

**Claim 3.** *There exists  $p_2 \in \mathring{B}_2(0, 1)$  such that if  $0 \leq \angle(C) \leq \frac{\pi}{4}$ ,*

$$\text{dist}_2\left(\frac{p_1 + p_2}{2}, p_2\right) \leq \text{dist}_2\left(\frac{p_1 + p_2}{2}, C\right), \quad \text{dist}_2\left(\frac{p_3 + p_2}{2}, p_2\right) \leq \text{dist}_2\left(\frac{p_3 + p_2}{2}, C\right).$$

*Similarly, there exist  $p'_2$ , where the same holds if  $\frac{\pi}{4} \leq \angle(C) \leq \frac{\pi}{2}$ , replacing  $p_2$  by  $p'_2$ .*

To prove Claim 3, increase  $\angle(C)$  from 0 to  $\frac{\pi}{4}$ , continuously: the union of the points of the changing squares  $C$  is denoted by  $C_1$  (see Figure 3.9 (a));  $C_1$  is a well-defined closed set. Note also that moving the candidate for  $p_2$  from  $p_3$  to  $p_1$  on  $\mathring{B}_2(p_0, 1)$ , the segment  $[p_2, p_3]$  increases, and  $[p_1, p_2]$  decreases. The two disks having these segments as diameters – denote these open disks by  $D_{23}, D_{12}$  –, also increase and decrease, respectively.

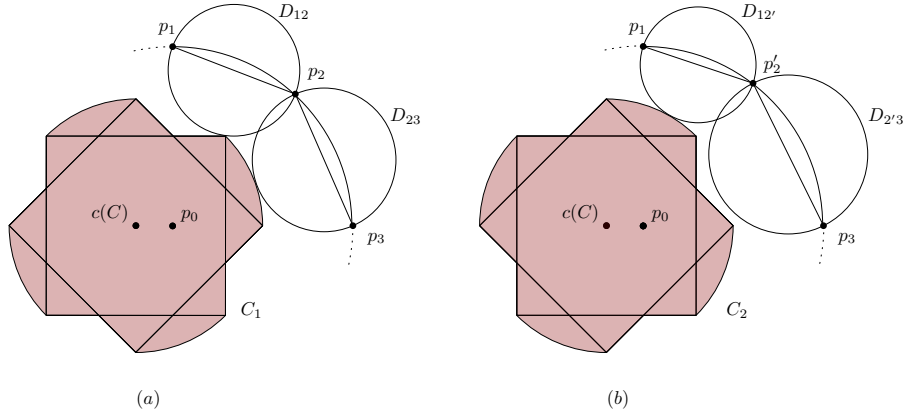

Figure 3.9: Representation of the sets  $C_1$  and  $C_2$ .

The assertion of Claim 3 for squares of  $\angle(C) \leq \frac{\pi}{4}$  is then clearly equivalent to the following: *There exists a point  $p_2$  for which both  $D_{23}$  and  $D_{12}$  are disjoint from  $C_1$ .*

Indeed, then

$$\begin{aligned} \text{dist}_2\left(\frac{p_1 + p_2}{2}, p_2\right) &\leq \text{dist}_2\left(\frac{p_1 + p_2}{2}, C_1\right) \leq \text{dist}_2\left(\frac{p_1 + p_2}{2}, C\right), \\ \text{dist}_2\left(\frac{p_2 + p_3}{2}, p_2\right) &\leq \text{dist}_2\left(\frac{p_2 + p_3}{2}, C_1\right) \leq \text{dist}_2\left(\frac{p_2 + p_3}{2}, C\right). \end{aligned}$$

With the  $t$  value provided by Claim 2,  $p_2 := (t + \cos(0.82), \sin(0.82))$  verifies this property.

Similarly, increasing  $\angle(C)$  from  $\frac{\pi}{4}$  to  $\frac{\pi}{2}$ ,  $C$  “sweeps”  $C_2$  (see Figure 3.9 (b)); moving now the candidate for  $p_2$  further, denote it  $p'_2$ , the open disks with diameter  $[p'_2, p_3]$ ,  $[p_1, p'_2]$  are both disjoint of  $C_2$  for instance if  $p'_2 := (t + \cos(0.92), \sin(0.92))$  (this is now an even easier choice than  $p_2$  was, because  $p'_2$  can be chosen from a larger arc). Claim 3 is proved.

Now, we can define the two sets hitting the neighbors of  $C$  according to  $\angle(C)$ . Recall that we fixed  $p_1 := (t, 1)$ ,  $p_5 := (t, -1)$ ,  $p_0 := (t, 0)$ ,  $p_3 := (t + 1, 0)$ , where  $t = \frac{\sqrt{4\sqrt{2}-5}}{4}$ , and we defined  $p_2$  and  $p'_2$  to satisfy Claim 3 under two different conditions that cover all the possibilities for  $C$ . Denote  $p_4$  the reflexion of  $p_2$  to the horizontal axis, and  $p'_4$  the reflexion of  $p'_2$ .

We show that all neighbors of  $C$  are hit by  $H_1 := \{p_0, p_1, p_2, p_3, p'_4, p_5\}$  if  $0 \leq \angle(C) \leq \frac{\pi}{4}$ , and by  $H_2 := \{p_0, p_1, p'_2, p_3, p_4, p_5\}$  if  $\frac{\pi}{4} \leq \angle(C) \leq \frac{\pi}{2}$ .

If  $S \in N(C)$ , then by Claim 1,  $c(S) \in Q$ . If furthermore  $c(S) \in Q_t$ , then we get from Claim 2 that already the 3-element subset  $\{p_0, p_1, p_5\}$  is hitting. Otherwise  $c(S) \in Q \setminus Q_t$ , where  $Q \setminus Q_t$  contains both  $P_1 := \text{conv}(p_0, p_1, p_2, p_3, p'_4, p_5)$  and  $P_2 := \text{conv}(p_0, p_1, p'_2, p_3, p_4, p_5)$ , which can be considered to be hexagons with the peculiarity that two sides are collinear, since  $p_0$  is contained in  $[p_1, p_5]$ .

In view of the application of Theorem 3.14, since  $C$  is not fully contained in  $Q \setminus Q_t$ , we replace it with  $C_t := C \cap \{(x, y) : x \geq t\}$ .

**Claim 4.** *If a unit square  $S \in N(C)$  satisfies  $c(S) \in Q \setminus Q_t$  and  $S \cap C_t \neq \emptyset$ , then  $S$  is hit by  $H_1$  if  $0 \leq \angle(C) \leq \frac{\pi}{4}$ , and by  $H_2$  if  $\frac{\pi}{4} \leq \angle(C) \leq \frac{\pi}{2}$ .*

To prove Claim 4, we assume  $0 \leq \angle(C) \leq \frac{\pi}{4}$ . The case with  $\frac{\pi}{4} \leq \angle(C) \leq \frac{\pi}{2}$  is the same by symmetry. We apply Theorem 3.14 considering  $P = P_1$ ,  $p_0 = p_0$ , and  $C = C_t$ . Observe that  $p_0$  plays the double role of corner of  $P_1$  and “center” in condition (i). Clearly,  $C_t \subseteq P_1$  and conditions (i) and (ii) are satisfied. We continue by checking the other conditions in (iii):

Note that  $c(S)$  is on the same side of the line  $L_5 = L_0$  containing  $[p_5, p_0]$ , and  $[p_0, p_1]$ . Therefore, looking at the additional assertion of Theorem 3.14 we need to check (iii) only for the indices in  $I := \{1, 2, 3, 4\}$ . Since  $0 \leq \angle(C) \leq \frac{\pi}{4}$ , Claim 3 makes sure that (iii) holds for  $i = 1$ , and  $i = 2$ . However, the angle of the vertex of  $C$  which is in the quadrant  $\mathbb{R}^+ \times \mathbb{R}^-$  is  $|\angle(C) - \frac{\pi}{2}| \geq \frac{\pi}{4}$ , and by symmetry this luckily means that (iii) holds for  $i = 3$  and  $i = 4$ . So it holds for all  $i \in I$ , and therefore the assertion of Theorem 3.14 can be applied, that is,  $S$  is hit by  $H_1 = \{p_0, p_1, p_2, p_3, p'_4, p_5\}$ , and Claim 4 is proved.

To conclude, we prove the following claim.

**Claim 5.** *Every neighbor of  $C$  is hit by  $H_1$  or  $H_2$  according to the angle  $\angle(C)$ .*

Indeed, assume for a contradiction that there is a square  $S \in N(C)$  that does not contain any point of  $H_1$  and  $H_2$ . We have that  $c(S) \in Q \setminus Q_t$ , otherwise,  $S$  satisfies the condition of Claim 2, and it would be hit by  $\{p_0, p_1, p_5\}$ . Similarly,  $S \cap C_t = \emptyset$ , otherwise,  $S$  satisfies the condition of Claim 4, and it would be hit by  $H_1$  or  $H_2$ . Hence, the vertical line  $L := \{(x, y) : x = t\}$  separates the points  $c(S)$  and  $c \in S$ . Now, we show  $\text{dist}_2(c, c(S)) > \frac{\sqrt{2}}{2}$ , proving that  $S \cap C = \emptyset$ , contradicting  $S \in N(C)$ .

The square  $S$  does not intersect any of the segments  $[a, b]$  for  $a, b$  two consecutive points in  $(p_1, p_2, p_3, p'_4, p_5)$  if  $0 \leq \angle(C) \leq \frac{\pi}{4}$ , or in  $(p_1, p'_2, p_3, p_4, p_5)$  if  $\frac{\pi}{4} \leq \angle(C) \leq \frac{\pi}{2}$ , otherwise we could apply Lemma 3.12 and since there is a square ( $S$  indeed) that contains  $c$ , but it is

not hit by  $\{a, b\}$  we would have

$$\text{dist}_2\left(\frac{a+b}{2}, a\right) > \text{dist}_2\left(\frac{a+b}{2}, c\right) \geq \text{dist}_2\left(\frac{a+b}{2}, C\right)$$

in contradiction with Claim 3.

Then  $[c(S), c]$  crosses the line  $L$  either above  $p_1$  or below  $p_5$ . We can assume that it crosses above  $p_1$  (the other case is symmetric). In particular, the horizontal line  $H := \{(x, y) : y = 1\}$  separates  $c$  and  $c(S)$ , denote by  $q$  the intersection point between  $[c(S), c]$  and  $H$  (see Figure 3.10).

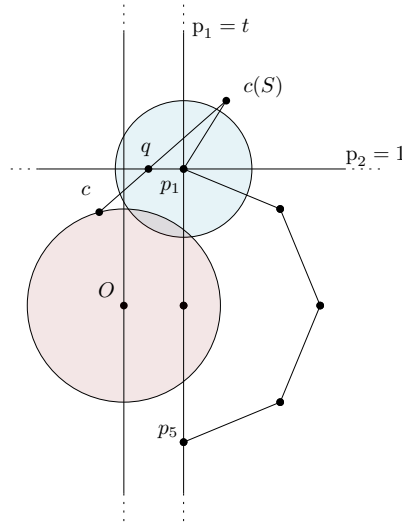

Figure 3.10: Representation of the center of a square that is not hit by any point in  $H_1$ .

It is easy to see that,  $\text{dist}_2(c(S), q) > \text{dist}_2(c(S), p_1) > \frac{1}{2}$  where the second inequality comes from the fact that  $p_1$  does not hit  $S$ , so  $c(S) \notin B_2(p_1, \frac{1}{2})$ , and  $\text{dist}_2(q, c) \geq 1 - \frac{\sqrt{2}}{2}$  since  $q$ , as  $p_1$ , has a vertical coordinate of 1 and  $c \in C$  lies below the line  $\{(x, y) : y = \frac{\sqrt{2}}{2}\}$ . Finally,

$$\text{dist}_2(c(S), c) = \text{dist}_2(c(S), q) + \text{dist}_2(q, c) > \frac{1}{2} + 1 - \frac{\sqrt{2}}{2} > \frac{\sqrt{2}}{2}.$$

□

**Proof of Theorem 3.2.** Let  $S$  be a square minimizing  $l(S')$ ,  $S' \in \mathcal{S}$ , and for the simplicity of the notations choose  $l(S') = 1$  to be of unit length.

Now for each square  $Q \in N[S] - S$ , fix a point  $p \in Q \cap S$  and let  $Q'$  be a unit square containing  $p$  and completely contained in  $Q$  (see Figure 3.11), and let  $N' := \{Q' : Q \in N[S] - S\}$ . We say that  $Q$  and  $Q'$  *correspond* to one another. Clearly, each  $Q' \in N'$  still intersects  $S$ , and for each point hitting a subset of  $N'$  the same point is hitting all the corresponding sets in  $N[S] - S$ . This is what we called *local homothety* in the introduction.

Since  $\{S\} \cup N'$  contains only unit squares, by Lemma 3.1  $\tau(N[S]) \leq \tau(N') \leq 10$ . Since we can iterate this procedure to any subfamily of  $\mathcal{S}$ , we proved that  $\mathcal{S}$  is hitting-10-degenerate, and Lemma 3.8 concludes the proof of the first statement of Theorem 3.2.

The proof of the second statement is analogous, and even simpler since now we directly have only unit squares, so by the second part of Lemma 3.1, there exists a square  $S$  with

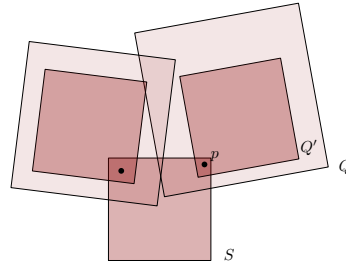
Figure 3.11: Transformation of the squares in  $N[S] - S$ .

the property  $\tau(N[S]) \leq 6$ . Therefore  $S$  is now hitting-6-degenerate, and we conclude by Lemma 3.8 again.  $\square$

We continue now with the proof of the lower bound:

**Proof of Theorem 3.3.** The proof consists in showing squares with  $\nu = 1$  and  $\tau = 3$  or  $\tau = 4$ , if the squares may have different sizes. The constructions borrow ideas of [11] for unit disks, or [33] for translations of a triangle.

Start by Figure 3.12 (a), and note that the three squares of the figure *can be hit by two points only if one of these points is a vertex of the triangle formed by one side of each*.

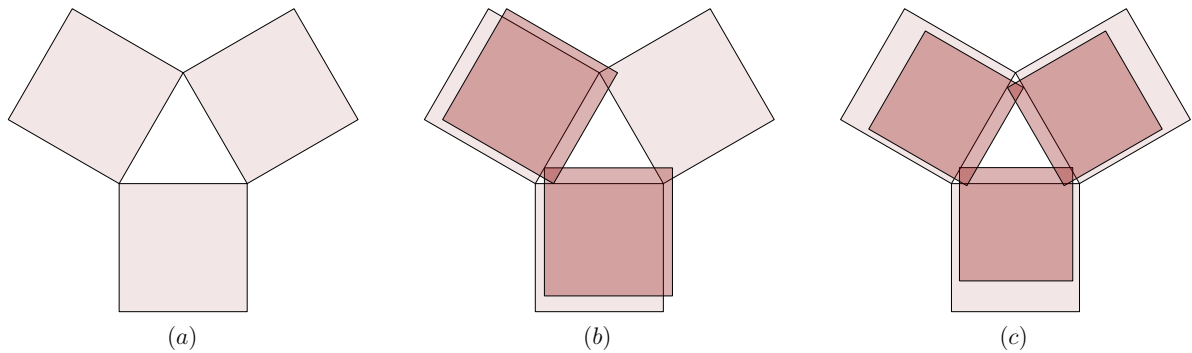
Figure 3.12: Pairwise intersecting squares with  $\nu = 1$ , and  $\tau = 2$  (a),  $\tau = 3$  (b), (c).

Add now a small shift of each of the two squares at each vertex as (b) shows for one of the three vertices. Six squares are added in this way, altogether, we mean a family of nine squares in the example (b). *We have  $\tau = 3$  for this family, since deleting any vertex of the triangle (as proved to be necessary) we need two more vertices.*

The same holds for the six squares of two different sizes with  $\nu = 1$  of (c), so we have  $\tau = 3$  for the same reason, and we use this to continue the construction with more squares for having  $\tau = 4$  while keeping  $\nu = 1$ .

To this end Figure 3.13 adds one more layer to Figure 3.12 (c). Figure 3.13 (a) contains Figure 3.12(a), but each of the three red squares of the latter is completed to a chain of 3 squares containing one another, an orange and a green one. Each color forms a triangle, and the six squares belonging to any pair of colors form a drawing “isomorphic” to Figure 3.12(c). (Mainly: the intersections of different pairs of squares of the same color are disjoint from one another.) Therefore the 6 rectangles of any two colors cannot be hit by less than 3 points. It follows that none of the intersection points of two red squares can be in a hitting set of size three, since it does not hit any orange or green square. Therefore *a hitting set of size three must contain one point of each red square.*

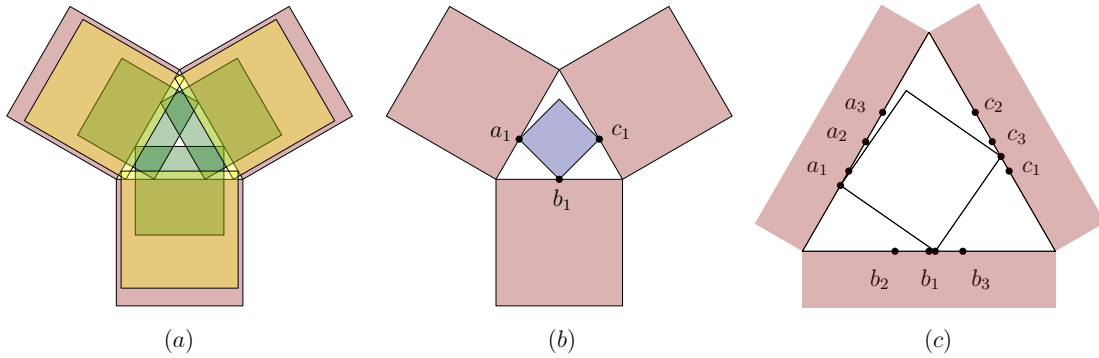

Figure 3.13: 13 pairwise intersecting squares with  $\nu = 1$ , and  $\tau = 4$ .

Now add three smaller (blue) squares touching all the three red squares, one of them in the middle point of a side, the two others symmetrically, one of these is drawn on Figure 3.13 (b), and on Figure 3.13 (c) all the three intersection points of blue points in the red squares are present. Since we also have to hit these blue squares, from the conclusion of the previous paragraph, we get that *the only hitting sets of size 3 are  $\{a_1, b_2, c_3\}$  and the 27 different symmetric versions of it*. We now have three squares of each of four colors.

Adding a thirteenth new square that does not contain any of the nine points  $a_1, b_1, c_1, a_2, b_2, c_2, a_3, b_3, c_3$  as in Figure 3.13 (c), obliging a fourth point of the hitting set that have been proved to be necessary for a hitting set of size three.  $\square$

Taking disjoint copies of the 13 squares of Figure 3.13, or of the 9 of Figure 3.12(c), we immediately obtain the following result:

**Corollary 3.16.** *There exists families of squares with arbitrarily large values of  $\nu$  such that  $\tau = 4\nu$ , and also of squares of equal size and  $\tau = 3\nu$ .*

### 3.4.3 Coloring squares

We prove here the upper bound for the chromatic number of a family of squares.

**Proof of Theorem 3.4:** To prove the first part of Theorem 3.4 we adapt the *averaging argument* already used in the proof of Lemma 1.7.

Let  $\mathcal{S}$  be a family of squares,  $G := G(\mathcal{S})$  the intersection graph of  $\mathcal{S}$ ,  $n := |\mathcal{S}|$ . Each point of a square can be contained in at most  $\Delta(\mathcal{S}) - 1$  other squares with some strict inequalities at the borders (for example, the left-most point that is a vertex of a square cannot be contained in any other square).

For each square  $R \in \mathcal{S}$  counting *twice* the pairs  $(v, R')$ ,  $v$  is a vertex of  $R$ ,  $R' \in N(R)$ ,  $v \in R \cap R'$ , and *only once* if  $v$  is the center of  $R$ , and  $v \in R' \in N(R)$ , we get less  $(2 \times 4 + 1)$  times the maximum degree of these vertices minus one, for each square. Adding these numbers for all squares, the sum we get is strictly less than  $9n(\Delta(\mathcal{S}) - 1)$ .

This sum counts each edge at least twice because if two squares have a vertex intersection, then there exists a pair  $(v, R)$ , such that  $v$  is a vertex of one of them,  $R$  is the other and  $v \in R$ , and this pair is counted twice; if they have a crossing intersection, then by Lemma 3.15 applied twice, both centers are in the intersection. Hence,  $2|E| < 9n(\Delta(\mathcal{S}) - 1)$ , and therefore the average degree of  $G$ , and then the minimum degree of  $G$  is strictly less

than  $9(\Delta(\mathcal{S}) - 1)$ . Applying this to any subgraph, we get that  $G$  is  $k$ -degenerate with  $k < 9(\Delta(\mathcal{S}) - 1)$ , and hence  $9(\Delta(\mathcal{S}) - 1)$ -colorable.

To prove the second part of the theorem, let now  $\mathcal{S}$  be a family of unit squares and  $S$  a square with a left-most center. Since any point in  $\mathbb{R}^2$  can be contained in at most  $\Delta(\mathcal{S})$  squares and, by Lemma 3.1, there are 6 points intersecting all the neighbors of  $S$  we have  $|N[S]| \leq 6\Delta(\mathcal{S})$ , so  $|N(S)| \leq 6\Delta(\mathcal{S}) - 1$ . Applying this to any subset of  $\mathcal{S}$  we get that  $\mathcal{S}$  is  $6\Delta(\mathcal{S}) - 1$ -degenerate, and therefore  $6\Delta(\mathcal{S})$ -colorable.  $\square$

Note that both parts of Theorem 3.4 proceed by degeneracy, but two different methods have been used: an averaging argument for squares in general, and Lemma 3.1 for unit squares. Both methods work for both parts, but for arbitrary squares Lemma 3.1 gives only  $10\Delta$  versus the  $9(\Delta - 1)$  upper bound due to the averaging argument, while for unit squares, the averaging argument does not obviously lead to anything better than  $9(\Delta - 1)$ , versus the  $6\Delta$  of the more sophisticated method of Lemma 3.1. For  $\Delta \leq 2$ , the former bound is better, though. In the next section, the averaging argument will be generalized to rectangles. To give a bound, the rectangles have to be constrained.

## 3.5 Rectangles

In this section, we extend the results to rectangles with a bounded aspect ratio. Recall that the *aspect ratio* of a rectangle  $R$  is  $\rho(R) := \frac{L(R)}{l(R)}$ , where  $L(R)$  (resp.  $l(R)$ ) denotes the length of the larger (resp. smaller) side of  $R$ . In Chapter 1 Theorems 1.27 and 1.15, we prove a bound on the ratio  $\tau/\nu$  and one on the ratio  $\chi/\omega$  of axis-parallel rectangles depending logarithmically on the aspect ratio. The first bound improved the linear bound of Ahlswede and Karapetyan [2, Statement 1]. Now, we generalize Theorems 3.2 and 3.4 for (not necessarily axis-parallel) rectangles showing bounds depending linearly on the aspect ratio (Sections 3.5.1 and 1.1).

It is crucial to be aware that the bounds for rectangles, in general, do need the aspect ratio. Indeed, the ratios  $\tau/\nu$  and  $\chi/\Delta$  can be arbitrarily large (see Figure 7 in the Section 0.5).

### 3.5.1 Hitting dancing rectangles

In this section, we are bounding the hitting number of a family of rectangles using its aspect ratio and its packing number. We define the *middle segment* of a rectangle  $R$  as the segment joining the midpoints of the two sides of length  $l(R)$ , and the *middle line*, as the line containing this segment. For squares, choose arbitrarily between the two sides.

**Theorem 3.17.** *Let  $\mathcal{R}$  be a family of rectangles in the plane with an aspect ratio of at most  $\rho$ , then*

$$\tau(\mathcal{R}) \leq \left( (\sqrt{7} + 1)\rho + 11 \right) \nu(\mathcal{R}).$$

*Proof.* We proceed by proving that  $\mathcal{R}$  is hitting- $(\sqrt{7} + 1)\rho + 11$ -degenerate. Then, the theorem follows by applying Lemma 3.8.

Let  $R$  be a rectangle in  $\mathcal{R}$  with the smallest side, and assume that the length of this side is 1. As a first step, we repeat the local homothety trick (shown in detail in Section 3.2.2): for each rectangle  $Q \in N(R)$ , fix a point  $p$  in  $Q \cap R$  and let  $Q'$  be a unit square containing  $p$



and completely contained in  $Q$ . This operation is possible since  $l(Q) \geq l(R) = 1$ . Clearly,  $Q'$  still intersects  $R$ , and no new intersections are created since  $Q' \subseteq Q$ . We denote the family of these unit squares by  $N'$ . Any hitting set of  $N'$  that includes a point in  $R$  is also a hitting set of  $N[R]$ . For this reason, it is enough to construct a hitting set for  $N'$ .

First, we define a set of points  $P$  that will be the hitting set for  $N'$ . In the proof of Lemma 3.1, the neighbors of a unit square were hit by placing one point in the center of the square and the remaining ones around it. To hit the neighbors of  $R$ , we consider an adapted approach: place some points on its middle segment  $s$ , some other points around its shorter sides, and the remaining ones on two lines  $L_1, L_2$  parallel to the middle line  $L$  and at a distance of  $d + \frac{1}{2}$  ( $d$  defined below) from  $L$ . The desired distance  $d$  satisfies the equation  $1 - (\frac{1}{2} + d)^2 = d^2$ , so  $d = \frac{\sqrt{7}-1}{4}$ . This particular choice of  $d$  has the property that for any point  $p$  in the middle segment of  $R$ , the circle  $\mathring{B}_2(p, 1)$  intersects  $L_i$  ( $i \in \{1, 2\}$ ) in two points, say  $a$  and  $b$ , such that  $\frac{\text{dist}_2(a,b)}{2} = \text{dist}_2(R, L_i) = d$  (see Figure 3.14).

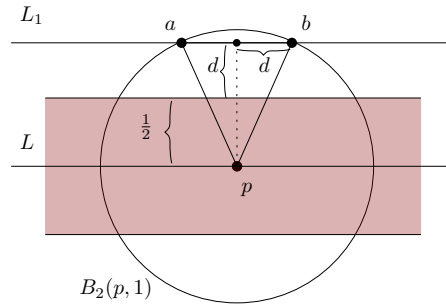

Figure 3.14: Definition of the distance  $d$ .

For simplicity of the notation, suppose that the horizontal axis coincides with the middle line  $L$  and the origin  $O$  is in the left endpoint of the middle segment  $s$ . Let  $t := \lceil \frac{\rho}{2d} \rceil$ , the set of points  $P$  is composed of:

- a set of  $t$  consecutive points  $\{p_0, \dots, p_{t-1}\}$  on  $L$  such that  $p_0$  has horizontal coordinate  $d$  and two consecutive points have distance  $2d$ ;
- two sets of  $t + 1$  consecutive points each,  $\{p_0^1, \dots, p_t^1\}$  on  $L_1$  and  $\{p_0^2, \dots, p_t^2\}$  on  $L_2$ , such that  $p_0^1$  and  $p_0^2$  have horizontal coordinates 0 and two consecutive points on each line have distance  $2d$ ;
- $c_1 = (-\frac{\sqrt{2}}{2} + d, \frac{\sqrt{2}}{2})$ ,  $c_2 = (-1 + d, 0)$ , and  $c_3 = (-\frac{\sqrt{2}}{2} + d, -\frac{\sqrt{2}}{2})$  on  $\mathring{B}_2(p_0, 1)$
- $c_4 = (\frac{\sqrt{2}}{2} + p_1(p_{t-1}), \frac{\sqrt{2}}{2})$ ,  $c_5 = (1 + p_1(p_{t-1}), 0)$ , and  $c_6 = (\frac{\sqrt{2}}{2} + p_1(p_{t-1}), -\frac{\sqrt{2}}{2})$  on  $\mathring{B}_2(p_{t-1}, 1)$ .

See Figure 3.15.

Notice that for any  $0 \leq i \leq t - 1$  the circle  $\mathring{B}_2(p_i, 1)$  intersects  $L_1$  in  $\{p_i^1, p_{i+1}^1\}$  and  $L_2$  in  $\{p_i^2, p_{i+1}^2\}$ , and

$$|P| = 3t + 8 \leq 3\left(\frac{\rho}{2d} + 1\right) + 8 = \frac{6\rho}{\sqrt{7}-1} + 11 = \rho(\sqrt{7} + 1) + 11.$$

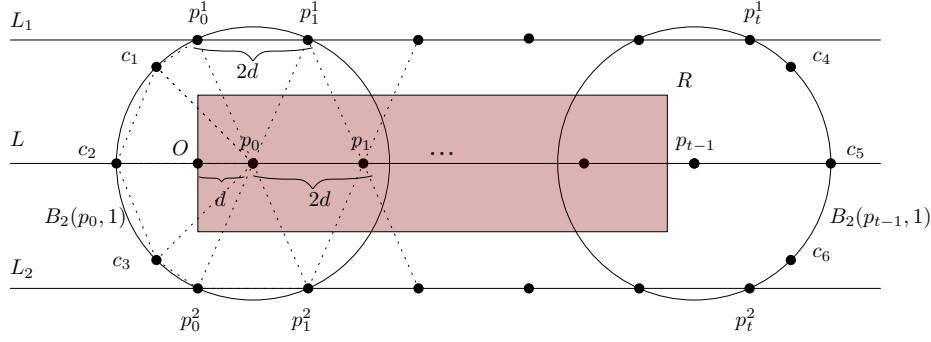

Figure 3.15: Hitting points of the neighbors of  $R$ .

The convex hull  $K := \text{conv}(P)$  can be decomposed in a family  $\mathcal{T}$  of triangles as in Figure 3.15. In  $\mathcal{T}$ , there are two types of triangles: the triangles of *type 1* formed by two unit radii of some  $B_2(p_i, 1)$  and one horizontal segment of length  $2d$ , such as  $\text{conv}(\{p_0, p_0^1, p_1^1\})$  and  $\text{conv}(\{p_0, p_1^1, p_1\})$ , and the ones of *type 2* formed by two unit radii and a chord of  $\overset{\circ}{B}_2(p_0, 1)$  or  $\overset{\circ}{B}_2(p_{t-1}, 1)$ , such as  $\text{conv}(\{p_0^1, p_0, c_1\})$  and  $\text{conv}(\{c_1, p_0, c_2\})$ .

**Claim 1.** *All triangles in  $\mathcal{T}$  have sides of length at most one.*

Indeed, the triangles of type 1 have two unit sides, and the third side of length  $2d < 0.83$ , while the triangles of type 2 also have two unit sides, and the third side of length either  $\text{dist}_2(p_0^1, c_1) < 0.36$  or  $\text{dist}_2(c_1, c_2) < 0.77$ .

**Claim 2.** *For each triangle in  $\mathcal{T}$ , let  $a, b$  be the endpoints of the shortest side and  $q$  the middle point of  $[a, b]$ . Then  $\text{dist}_2(a, q) \leq \text{dist}_2(R, q)$ .*

Indeed, if  $a$  and  $b$  are corners of a triangle of type 1, then, by the choice of  $d$ ,  $\text{dist}_2(a, q) = \text{dist}_2(R, q) = d$ . Otherwise,  $a$  and  $b$  are corners of a triangle of type 2. Then we can assume  $\{a, b\}$  on  $\overset{\circ}{B}_2(p_0, 1)$  since if they are on  $\overset{\circ}{B}_2(p_{t-1}, 1)$ ,  $q$  is even farther from  $R$ . By symmetry, it is enough to check the condition for  $(a, b) = (p_0^1, c_1)$  and  $(a, b) = (c_1, c_2)$ . In the first case, an easy computation gives  $\text{dist}_2(a, q) < 0.18$  and  $0.34 < \text{dist}_2(R, q)$ , while in the second case,  $\text{dist}_2(a, q) < 0.39$  and  $0.44 < \text{dist}_2(R, q)$ . This concludes the proof of Claim 2.

Finally, we show that for any unit square  $S$  intersecting  $R$ ,  $P \cap S \neq \emptyset$ . We cannot use Theorem 3.9 directly because we do not have a unique point that satisfies condition (i), so we use Lemmas 3.10 and 3.12 separately: if  $c(S) \in K$ , then there exists a triangle  $T \in \mathcal{T}$ , such that  $c(S) \in T$ . By Claim 1, we can apply Lemma 3.10 to  $T$  and conclude that one of its corners hit  $R'$ . Otherwise, if  $c(S) \notin K$ , then let  $c \in S \cap K$ . Since  $c \in K$ , there exists a side of the polytope  $K$ , say  $[a, b]$ , whose line separates  $c(S)$  and  $c$ . The segment  $[a, b]$  is the shortest side of a triangle  $T \in \mathcal{T}$ . Now according to Claim 2, the condition of Lemma 3.12 is satisfied for  $c, a, b$ , and therefore the set  $\{a, b\} \subseteq P$  hits  $S$ .

In conclusion,  $P$  hits any unit square intersecting  $R$ , so in particular  $N'$  and consequently  $N[R]$ . Since  $\mathcal{R}$  can be substituted by any subset of  $\mathcal{R}$ , we have proved the claimed hitting-degeneracy result, and the theorem follows.  $\square$

### 3.5.2 Coloring rectangles

Pach's simple bound on the chromatic number for general families of convex sets (Section 3.1) could be improved for squares (Theorem 3.4). We now extend the approach to rectan-

gles with a bounded aspect ratio, completing the result on axis-parallel rectangles (Theorem 1.15).

**Theorem 3.18.** *Let  $\mathcal{R}$  be a family of rectangles in the plane with an aspect ratio of at most  $\rho$  and  $\Delta(\mathcal{R}) \geq 2$ , then*

$$\chi(\mathcal{R}) \leq 2(\rho + 4)(\Delta(\mathcal{R}) - 1).$$

The centers of squares played an essential role in the proof of Theorem 3.4 (mainly Lemma 3.15). For this reason, defining a specific notion of “center” for rectangles is also useful. We define the  $\rho$ -centers of a (not necessarily axis-parallel) rectangle  $R$  as the points  $p_1^R, \dots, p_{\lceil \rho \rceil}^R$  that correspond to the centers of the  $\lceil \rho \rceil$  rectangle of side lengths  $l(R)$  and  $\frac{l(R)}{\rho}$  contained in  $R$  (see Figure 3.16).

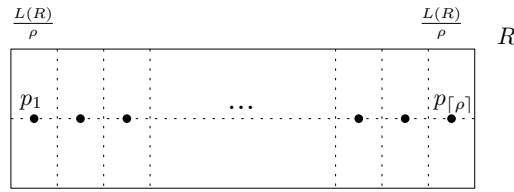

Figure 3.16: Points in  $R$ .

**Lemma 3.19.** *If two rectangles  $R$  and  $R'$  have a crossing intersection and  $l(R') \geq \frac{l(R)}{2}$ , then the middle segment of  $R$  intersects  $R'$ .*

*Proof.* Suppose for a contradiction that the middle segment of  $R$  does not intersect  $R'$ . Then, by convexity,  $R' \cap R$  is completely on one side, say above the middle segment of  $R$ . Since  $R$  and  $R'$  cross, two parallel sides of  $R'$  cross the short side of  $R$  in its part above the middle line (Figure 3.17), implying  $l(R') < \frac{l(R)}{2}$ , a contradiction.  $\square$

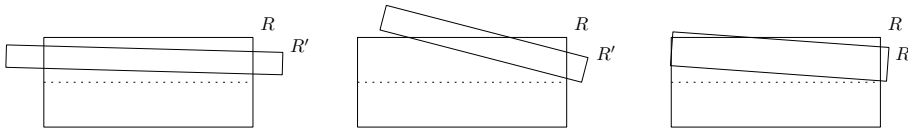

Figure 3.17: Crossing rectangles  $R, R'$ , where  $R'$  does not intersect the middle segment of  $R$ .

**Lemma 3.20.** *Let  $R, R'$  be two rectangles in the plane. If  $R$  and  $R'$  have a crossing intersection, then  $R \cap R'$  contains at least one of the  $\rho$ -centers of  $R$  or one of  $R'$ .*

*Proof.* Let  $R$  and  $R'$  be two rectangles in  $\mathcal{R}$  having a crossing intersection and assume that  $l(R') \geq l(R)$ . We denote by  $s$  the middle segment of  $R$ , by  $p$  and  $q$  its endpoints. We show that at least one of the centers  $p_1^R, \dots, p_{\lceil \rho \rceil}^R$  is contained in  $R'$ .

By Lemma 3.19,  $s$  intersects  $R'$ . We have to consider three cases according to whether  $i := |R' \cap \{p, q\}|$  is 2, 1 or 0. If  $i = 2$ , then  $[p, q] \in R'$ , so all the centers of  $R$  are in  $R'$ . If  $i = 1$ , then assume  $p \in R'$  and let  $x'$  be the corner of  $R$  closer to  $p$ . We consider two cases depending on whether  $s$  crosses a side of  $R'$  that is incident to  $x'$  or not (Figure 3.18 (a),(b)). If  $i = 0$ , then we have two further cases depending on whether  $s$  crosses two parallel or incident sides of  $R'$  (Figure 3.18 (c),(d)). Elementary geometric observations show that in each of these four cases, at least one of the  $\rho$ -centers of  $R$  is in  $R'$ , concluding the proof.  $\square$

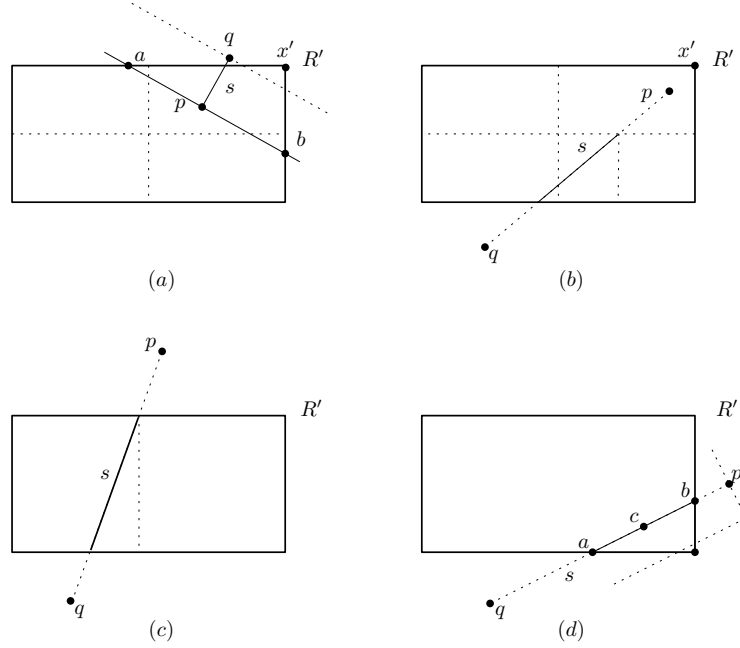

Figure 3.18: Some possible intersections between  $s$  and  $R'$ .

**Proof of Theorem 3.18:** Let  $\mathcal{R}$  be a family of rectangles with aspect ratio bounded by  $\rho$  and  $G := G(\mathcal{R})$  the intersection graph of  $\mathcal{R}$ ,  $n := |\mathcal{R}|$ . Each point of a rectangle can be contained in at most  $\Delta(\mathcal{S}) - 1$  other rectangles with some strict inequalities at the borders. Counting *once* for each rectangle  $R$  the pairs  $(v, R')$ , where  $v$  is a vertex or a  $\rho$ -center of  $R$ , and  $v \in R' \in N(R)$  and adding these numbers for all rectangles, the sum we get is strictly less than  $(4 + \rho)n(\Delta(\mathcal{S}) - 1)$ . This sum counts each edge at least once because if two rectangles  $R, R'$  have a corner intersection, then at least one of their eight vertices is counted, and if they have a crossing intersection, then, by Lemma 3.20, at least one of the  $\rho$ -centers of  $R$  or  $R'$  is counted. Hence,  $2|E| < 2(\rho + 4)n(\Delta(\mathcal{R}) - 1)$  and the minimum degree of  $G$  is strictly less than  $2(\rho + 4)(\Delta(\mathcal{R}) - 1)$ , allowing us to conclude by Lemma 0.7.  $\square$

### 3.6 Conclusion and open questions

In this chapter, we provided the best linear bounds we could for the hitting number of squares in the plane: Theorem 3.2 provides the upper bounds, and Theorem 3.3 the lower bounds, both proved in Section 3.4. These establish the worst  $\tau/\nu$  ratio in the interval  $[3, 6]$  for unit squares and in  $[4, 10]$  for squares in general. Finding the correct value remains elusive even for the special case when  $\nu = 1$ , meaning that the squares are pairwise intersecting. Grünbaum [46] mentioned that any family of pairwise intersecting translates and rotations of a fixed convex set can be hit by a constant number of points, depending on the convex object. For the particular case of unit disks, H. Hadwiger and H. Debrunner [51] provided an exact result showing that 3 points can hit any family of pairwise intersecting unit disks and that 3 points are sometimes necessary. For unit squares 3 points are necessary Theorem 3.3, and it is not difficult to show that 4 points are sufficient. We wonder if this bound can be improved or if a better lower bound can be achieved. We ask the

following questions:

**Question 3.21.** *Can every family of pairwise intersecting unit squares be hit by 3 points?*

**Question 3.22.** *Is there a family of squares with  $\frac{\tau}{\nu} > 4$ ?*

The bounds for the hitting number we established are based on hitting-degeneracy (Lemma 3.8). The greedy local induction of this approach is almost tight: Figure 3.19 presents a unit square  $S$  with  $\tau(N[S]) = 7$ , moreover, removing the three squares to the left of  $c(S)$  we have an example of a unit square with left-most center and  $\tau(N[S]) = 5$ , which shows the limits of this method. Though, there is no reason to think that the bounds of Theorem 3.2 cannot be improved with other methods.

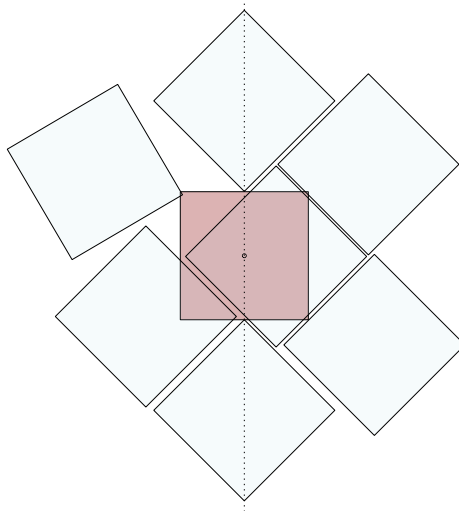

Figure 3.19: Unit square with seven pairwise disjoint neighbors.

Considering the chromatic number analogous questions can be asked. In the literature, we could not find any lower bound on the ratio  $\frac{\chi}{\nu}$  better than  $\frac{3}{2}$  neither for translations and homothecies of a fixed convex set, nor for translates and rotations. Families of axis-parallel squares and (not necessarily axis-parallel) unit squares are two particular examples of these families. We ask the following questions:

**Question 3.23.** *Is there a family of axis-parallel squares, or not necessarily axis-parallel unit squares, with  $\frac{\chi}{\omega} > \frac{3}{2}$ ?*

Finding the correct value of  $\sup \frac{\chi}{\omega}$  for squares is an open problem also in the particular case  $\omega = 2$ , that is when the intersection graph is triangle-free. Pereplitsa [79, Corollary 8] showed that any triangle-free family of axis-parallel squares is 3-colorable. Her results follow directly from Grötzsch's theorem, once observed that the intersection graph of such a family is planar. Allowing the squares to rotate, this property is lost, but this change may not significantly impact the chromatic number:

**Question 3.24.** *What is the smallest  $k$  such that any triangle-free family of squares is  $k$ -colorable?*

“Triangle-free” means  $\omega \leq 2$  here. A method similar to the one used by Pereplitsa [79] can be used to show 6-colorability, but we do not know any better bound. According to Theorem 3.4 the answer is between 3 and 9 under the weaker condition  $\Delta \leq 2$ .

## Chapter 4

# Boxicity of popular graphs and Kneser graphs

The *boxicity* of a graph is the minimum dimension  $d$  such that the graph is the intersection graph of a family of axis-aligned boxes in  $\mathbb{R}^d$ . The problem of deciding the boxicity of a graph is  $\mathcal{NP}$ -hard, even for  $d = 2$ . Even though no efficient algorithms can be expected, the research on the subject necessitates developing strong enough methods for executing this task for small concrete graphs or, hopefully, relevant classes of graphs.

There are notable examples between 10 and 20 vertices, such as the Petersen graph, the Grötzsch graph, and some of the smallest Ramsey graphs, for which finding the exact value of the boxicity has been an intriguing challenge for decades, and no solutions, or only complicated ones, exist. The needs to clarify the situation for graphs of small sizes are beyond self-interest: showing that particular graphs with “interesting” values of invariants (such as the stability number, chromatic number, or the clique number) have boxicity two would refute, or provide new tight examples, for well-known open problems such as Wegner’s conjecture.

In this chapter, we develop systematic methods to calculate the boxicity of concrete examples. After introducing the main notations and properties of the boxicity of a graph (Section 4.1), we prove a set of properties for graphs with boxicity two, that we call rectangle graphs (Section 4.2). These techniques are based on the simple fact that interval graphs do not contain induced cycles. Hence it is also possible to use them to study another parameter, similar to the boxicity, the *chordality* (that is, the minimum number of chordal graphs whose intersection is the graph itself). In Section 4.3, we apply our method to two popular graphs: the Ramsey graph on 13 vertices and the Grötzsch graph. After proper preparation, it will be easy to show that both have boxicity 3. Moreover, we discuss a natural algorithm to efficiently recognize rectangle graphs of small orders. Using this, we could find the order of the smallest triangle-free rectangle graph with a chromatic number of 4. We conclude the chapter with Section 4.4 by showing that the Petersen graph has boxicity 3. Even if our algorithm can quickly verify that the Petersen graph is not a rectangle graph, its characteristics make it challenging to show it “by hand”. This challenge stimulated new techniques based on the size of the minimal interval completion (the interval completion of a graph  $G$  is the smallest interval supergraph of  $G$ ). More generally, this method can be applied to the complement of line graphs, and, with a small additional effort, we use it to compute the boxicity of the complement of the line graph of  $K_n$  for any  $n \geq 5$ . This graph is also

known as the *Kneser graph*  $K(n, k)$  considering the values  $n \geq 5$  and  $k = 2$ . The problem of finding the boxicity of the Kneser graph was initially proposed to us by Matěj Stehlík.

This is joint work with András Sebő [15].

## 4.1 Introduction

Given a graph  $G$ , the *boxicity* of  $G$ , denoted by  $\text{box}(G)$ , is the minimum dimension  $d$  such that  $G$  is the intersection graph of a family  $\{B_v\}_{v \in V}$  of axis-aligned boxes in  $\mathbb{R}^d$ . A graph  $G$  has  $\text{box}(G) = 0$  if and only if  $G$  is a complete graph, and  $\text{box}(G) = 1$  if and only if it is an interval graph. We say that a graph with boxicity at most 2 is a *rectangle graph*. Boxicity was first introduced by Roberts in 1969 [82]. It can be applied to problems of niche overlap (competition) in ecology and fleet maintenance in operations research (see [29] for more details).

In the last decades, boxicity has been the subject of several studies. These have shown that it is  $\mathcal{NP}$ -hard to recognize graphs with boxicity  $d$ , even if  $d = 2$  [64], and generally, it is not easy to predict the boxicity of a class of graphs. Indeed, there are both “relatively simple” graph classes with bounded and unbounded boxicity:

On the one hand, outerplanar graphs and triangle-free planar graphs have boxicity at most two [83, 87]; planar graphs have boxicity at most three [87], and more generally, any graph that can be embedded in a surface of genus  $g$  has boxicity at most  $5g + 3$  [35]. On the other hand, other classes of graphs have unbounded boxicity, although they are considered to be “close” to interval graphs in some respect. This is the case for chordal graphs (even split graphs [29]) and circular arc graphs [9].

In Sections 4.3 and 4.4, we address three well-known graphs with specific graph invariant values: a Ramsey graph on 13 vertices, the Grötzsch graph, and the Petersen graph. Dealing with an  $\mathcal{NP}$ -hard problem, we cannot expect to come out with a general method. Still, we aim to collect various ideas that can simplify the recognition of rectangle graphs in multiple cases.

Let us point out that the need to clarify the situation for graphs, even if of a small order, is beyond self-interest. Any personal computer can efficiently deal with graphs of small order and quickly compute many invariants such as the stability number, the clique number, the chromatic number, and the clique cover number. Hence, there is an excellent choice for possible counterexamples and tight examples for our conjectures about rectangle graphs, mainly Wegner’s conjecture (Conjecture 1.17) and the analog problem for the chromatic number,  $\chi \leq 3\omega$  (see Questions 1.4 and 1.14). A way of formalizing this is to reformulate Wegner’s conjecture in terms of boxicity:

**Conjecture 4.1** (Reformulation of Conjecture 1.17). *If for a graph  $G$  the inequality  $\theta(G) \geq 2\alpha(G)$  holds, then  $\text{box}(G) \geq 3$ .*

In the following proposition, we show that Wegner’s conjecture and the analogous question for the chromatic number hold for graphs with a “considerable” number of vertices.

**Proposition 4.2.** *Let  $G$  be a rectangle graph with  $n$  vertices. Then Wegner’s conjecture holds if  $n \leq 16$  and the inequality  $\chi(G) \leq 3\omega$  holds if  $n \leq 25$ .*

*Proof.* From the work of Gyárfás, Sebő, and Trotignon [50]: the *chromatic gap* is the difference between the chromatic number and the clique number of a graph and, similarly, the *covering gap* is the difference between the clique covering number and stability number of a graph. For a positive integer  $k$ , denote by  $\text{gap}(k)$  the smallest order of a graph with gap  $k$ .

First, since  $\text{gap}(4) = 17$ , if  $n \leq 16$ , the gap is at most 3, so for every rectangle graph on  $n$  vertices  $\theta(G) - \alpha(G) \leq 3$ . If in addition  $3 \leq \alpha(G) - 1$ , we have  $\theta(G) - \alpha(G) \leq 3 \leq \alpha(G) - 1$



and Wegner's conjecture is proved. So we can suppose  $\alpha \leq 3$ , but then for every rectangle graph  $\theta(G) \leq 5$  (Theorem 1.20).

Then, since  $\text{gap}(7) > 25$ , if  $n \leq 25$ , the gap is at most 6, so for every rectangle graph on at most  $n$  vertices  $\chi(G) - \omega(G) \leq 6$ . Similarly to the previous paragraph, we are done if  $6 \leq 2\omega$ . Moreover, triangle-free rectangle graphs have a chromatic number of at most 6 (Theorem 1.8), so  $\omega \leq 2$  implies  $\chi \leq 6$  independently of the number of vertices.  $\square$

Let  $k$  and  $n$  be two positive integers such that  $n \geq 2k + 1$ . The *Kneser graph*  $K(n, k)$  is the graph with vertex set given by all subsets of  $[n] := \{1, 2, \dots, n\}$  of size  $k$  where two vertices are adjacent if their corresponding  $k$ -sets are disjoint. The notion of the Kneser graph appeared in 1956 in a paper by Kneser [61], where he conjectured that the chromatic number  $\chi(K(n, k))$  is equal to  $n - 2k + 2$ . In 1978 Lovász [69] settled this conjecture with an original topological proof. Since then, several papers have focused on the properties of this family, see for example [21, 39, 54]. For  $k = 2$  the Kneser graph  $K(n, 2)$  is the complement of the line graph of  $K_n$ . Pushing further our method, we compute the boxicity of the Petersen graph (that is,  $K(5, 2)$ ) and, more generally, we show that  $\text{box}(K(n, 2)) = n - 2$  for any  $n \geq 5$ . This settles an open problem left in our work with Lyuben Lichev [14, Conjecture 6.1].

In the remaining part of this introductory section, we show a couple of simple but useful lemmas to obtain upper bounds on the boxicity of a graph.

An axis-aligned box in  $\mathbb{R}^d$  is a Cartesian product  $I_1 \times I_2 \times \dots \times I_b$  where each  $I_i$  is a closed interval in the real line. Axis-parallel boxes  $B, B'$  intersect if and only if for all  $1 \leq i \leq d$  the intervals  $I_i$  and  $I'_i$  intersect. This simple fact immediately implies the following lemma.

**Lemma 4.3** (Roberts, 1969). *Let  $G = (V, E)$  be a simple graph. Then  $\text{box}(G) \leq k$  if and only if there are  $k$  interval graphs  $\{G_i\}_{1 \leq i \leq k}$  on the vertex set  $V(G)$  such that  $E(G) = E(G_1) \cap E(G_2) \cap \dots \cap E(G_k)$ .*

Note that by deleting or adding an edge, the boxicity may increase! However, for any graph  $G = (V, E)$  and  $v \in V$ ,  $\text{box}(G[V \setminus \{v\}]) \leq \text{box}(G) \leq \text{box}(G[V \setminus \{v\}]) + 1$ . We state and prove a stronger fact that contains this remark:

**Lemma 4.4** (Roberts, 1969). *Let  $G = (V, E)$  be a simple graph. If  $u, v \in V$  and  $uv \notin E$ , then  $\text{box}(G) \leq \text{box}(G[V \setminus \{u, v\}]) + 1$ .*

*Proof.* Let  $V' := V \setminus \{u, v\}$ ,  $G' := G[V']$ ,  $d' := \text{box}(G')$ , and  $\mathcal{B}'$  a family of boxes in  $\mathbb{R}^{d'}$  such that  $G(\mathcal{B}') = G'$ . Denote by  $B'_t$  the box associated to the vertex  $t \in V'$ . To obtain a representation of  $G$ , we embed the boxes of  $\mathcal{B}'$  in  $\mathbb{R}^{d'+1}$  and add two additional boxes representing  $u$  and  $v$ . First, for all  $t \in V'$ , define:

- $B_t := B'_t \times [0, 1]$ , if  $t \in N(u) \setminus N(v)$ ;
- $B_t := B'_t \times [-1, 0]$ , if  $t \in N(v) \setminus N(u)$ ;
- $B_t := B'_t \times [-1, 1]$ , if  $t \in N(u) \cap N(v)$ ;
- $B_t := B'_t \times \{0\}$ , if  $t \notin N(u) \cup N(v)$ .

The intersection of each box in  $\{B_t\}_{t \in N(u)}$  with the hyper-plane  $\{x \in \mathbb{R}^{d'+1} : p_{d'+1}(x) = 1\}$  is non-empty and there exists a box  $B_u$  in this hyper-plane, containing all the intersections. Similarly, each box in  $\{B_t\}_{t \in N(v)}$  has non-empty intersection with  $\{x \in \mathbb{R}^{d'+1} : p_{d'+1}(x) = -1\}$  and there exists a box  $B_v$  containing these intersections. Now,  $\mathcal{B} := \{B_t\}_{t \in V'} \cup \{B_u, B_v\}$  and clearly,  $G(\mathcal{B}) = G$ .  $\square$

By induction on the number of vertices of the graph, we can easily obtain the following results of Roberts [82].

**Theorem 4.5** (Roberts, 1969). *Let  $G = (V, E)$  be a simple graph on  $n$  vertices. Then  $\text{box}(G) \leq \lfloor \frac{n}{2} \rfloor$ .*

In particular, every graph with less than 6 vertices is a rectangle graph. Trotter [89] showed that, up to isomorphism, there is only one graph of order 6 and boxicity 3. This graph will be present in Theorem 4.11.

## 4.2 Properties of co-rectangle graphs

Roberts' reformulation of the definition of boxicity (Lemma 4.3) has been put in a slightly different form by Cozzens and Roberts that was more comfortable for deducing first bounds on the boxicity:

We say that the family of edge sets of a graph  $G = (V, E)$ ,  $\mathcal{C} = \{C_1, \dots, C_k\}$  ( $C_i \subseteq E$ ) is a *co-interval-cover*, or a *k-co-interval-cover* of  $E$  (or  $G$ ) if  $\cup_{i=1}^k C_i = E$ , and each  $(V, C_i)$  is a co-interval graph. The  $C_i$  will mostly be called colors: an edge in  $C_i$  will be said to have *color i*; for two colors, we will also use the words “blue” and “red”, and for any subset of edges  $F \subseteq E$ ,  $F_{\text{blue}}$  is the set of blue edges of  $F$  and  $F_{\text{red}}$  the set of red edges. Some edges will have several colors, which is necessary to make each color a co-interval graph, so  $F_{\text{blue}} \cap F_{\text{red}}$  is not necessarily empty; an edge will be called *pure* if it has only one color. The set of pure edges is the symmetric difference  $F_{\text{blue}} \Delta F_{\text{red}}$ .

**Lemma 4.6** (Cozzens and Roberts, 1982). *Let  $G$  be a graph. Then  $\text{box}(G) \leq k$  if and only if  $\overline{G}$  has a  $k$ -co-interval-cover.*

This immediately follows from the “de Morgan” law by taking the complement of intersections of sets, noting that we have to do this for graphs defined on  $V(G)$  for each of the  $C_i$  participating in the co-interval-cover. However, this does not have to be required in the definition of co-interval covers since adding isolated vertices to a co-interval graph, we still have a co-interval graph (indeed, for each isolated vertex, add an interval containing all the others).

From the class of forbidden induced subgraphs characterizing interval graphs, we will use two extensively: cycles of sizes four and five. For practical uses, we refer to this (easy) part of the characterization of Lekkerkerker and Boland [67] in the following lemma.

**Lemma 4.7.** *Let  $G$  be an interval graph. Then  $G$  does not contain:*

- (a) *a copy of  $C_4$  as induced subgraph, or equivalently,  $\overline{G}$  does not contain an induced  $2K_2$ .*
- (b) *a copy of  $C_5$  as induced subgraph, or equivalently,  $\overline{G}$  does not contain an induced  $C_5$ .*

*In particular, in a 2-co-interval-cover, both edges of any induced  $2K_2$  are pure and of different colors, and the five edges of an induced  $C_5$  do not have a common color.*

A *k-chord*  $k \in \mathbb{N}$  of a path or cycle  $P$  is an edge between two vertices at distance  $k$  (joined by a subpath of  $k$  edges) on  $P$ , so for cycles,  $k$  is always at most half of the length. A path is called  *$P_4$ -inducing* if it has neither 2-chords nor 3-chords, that is, if any three

consecutive edges form an induced  $P_4$ . A  $k$ -co-chord of  $P$  is a co-edge (that is, an edge in  $\overline{P}$ ) between two vertices at distance  $k$  on  $P$ . If  $P$  is a  $P_4$ -inducing path of length 3, then it induces a  $P_4$ , but if it is of length 4, it can induce a  $P_5$  or a  $C_5$ . Clearly, a  $P_4$ -inducing path may also be of arbitrary length. We use a consequence of Lemma 4.7 in the following form:

**Corollary 4.8.** *A co-interval graph does not contain any  $P_4$ -inducing path of length four. In other words, if a co-interval-cover of a  $P_4$ -inducing path has a common color, then it is of length at most three.*

*Proof.* Suppose for a contradiction that  $P$  is a  $P_4$ -inducing path of 4 consecutive edges on 5 vertices. Then the only chord of  $P$  is a 4-chord, that is, one joining its endpoints. However, by Lemma 4.7 (b), there is no edge between the two endpoints of  $P$ . But then the first and last edge of  $P$  form an induced  $2K_2$ , contradicting Lemma 4.7 (a).  $\square$

The *chordality* of a graph  $G$  is the smallest possible  $k$  for which a  $k$ -co-chordal-cover exists in  $G$  (replacing co-interval graphs by co-chordal graphs in the definition of cover) [70]. Since our key Lemma 4.7 trivially holds for chordal graphs, many of the boxicity results of this chapter can be generalized to chordality.

Since most of the results concern rectangle representations, we are particularly interested in 2-co-interval-covers. The following theorem describes the color pattern of paths and cycles: essentially, two colors are alternating in sequences of length 2 and 3 and only rare intersections.

**Theorem 4.9.** *Let  $G$  be a graph given with a 2-co-interval-cover  $\{E_{\text{blue}}, E_{\text{red}}\}$  and  $Q$  a  $P_4$ -inducing path or cycle on  $n$  vertices. Then*

- (a) *each component  $C_{\text{blue}}$  of  $Q_{\text{blue}}$  and  $C_{\text{red}}$  of  $Q_{\text{red}}$  is a 2-path or a 3-path;*
- (b) *for each pair of components  $C_{\text{blue}}$  of  $Q_{\text{blue}}$  and  $C_{\text{red}}$  of  $Q_{\text{red}}$ ,  $|E(C_{\text{blue}}) \cap E(C_{\text{red}})| \leq 1$ , and if the equality holds  $|E(C_{\text{blue}})| = |E(C_{\text{red}})| = 3$ . Moreover, for each component, there is at most one such equality;*
- (c) *if  $Q$  is a cycle and  $n$  is odd, then the number of 3-paths in  $Q_{\text{blue}}$  and  $Q_{\text{red}}$ , minus the number of edges having both colors, has the same rest as  $n$  modulo 4.*

*Proof.* We start with two coloring properties of three consecutive edges inducing a  $P_4$ .

**Claim 1.** *If three edges  $e_1, e_2, e_3$  induce a  $P_4$  and edges  $e_1, e_3$  have a common color, then  $e_2$  has also the same color.*

Indeed, if  $e_1$  and  $e_3$  have a common color, say red, but  $e_2$  is a pure blue edge then  $\{e_1, e_3\}$  forms an induced  $2K_2$  in the red subgraph, contradicting Lemma 4.7 (a).

**Claim 2.** *If three edges  $e_1, e_2, e_3$  induce a  $P_4$  and edge  $e_2$  is pure, then either  $e_1$  or  $e_3$  is also pure, and of the same color.*

Indeed, if neither  $e_1$  nor  $e_3$  is pure, or simply if both  $e_1$  and  $e_3$  have a common color different from the one of  $e_2$ , then they induce an induced  $2K_2$  of that color, contradicting Lemma 4.7 (a).

First, we prove Statement (a). By Corollary 4.8, each component  $C_{\text{blue}}$  and  $C_{\text{red}}$  is a path of length at most 3, so we just need to show that it has length at least 2. Assume for a contradiction that there exists a component that is a 1-path, say  $C_{\text{blue}}$ . Let  $e$  be the edge in this component, and consider four consecutive edges  $e_1, e_2, e_3, e_4$  in  $Q$  such that  $e_2 = e$ .

The edges  $e_1, e_3$  are not in  $C_{\text{blue}}$ , so they are pure red edges. Then,  $e$  also has the red color by Claim 1 applied to  $e_1, e, e_3$ , and so  $e_4$  is a pure red edge by Claim 2 applied to  $e, e_3, e_4$ . Now, the four considered edges are red, contradicting Corollary 4.8.

Now, we proceed with Statement (b). Assume for a contradiction that  $|E(C_{\text{blue}}) \cap E(C_{\text{red}})| \geq 2$  and consider four consecutive edges  $e_1, e_2, e_3, e_4$  in  $Q$  such that  $e_1, e_2 \in E(C_{\text{blue}}) \cap E(C_{\text{red}})$ . By Corollary 4.8, these four edges cannot have a common color, so we can assume  $e_3$  is a pure blue edge and  $e_4$  is a pure red edge. Then,  $\{e_2, e_4\}$  induces a red  $2K_2$ , in contradiction with Lemma 4.7 (a). So, the inequality in (b) is proved.

To finish the proof of Statement (b), let us analyze when  $|E(C_{\text{blue}}) \cap E(C_{\text{red}})| = 1$ . Let  $e$  be the only edge in this intersection and consider the five consecutive edges  $e_1, e_2, e_3, e_4, e_5$  in  $Q$  such that  $e = e_3$ . By the proven inequality of Statement (b), the edges  $e_2$  and  $e_4$  are pure. Moreover, they have opposite colors, otherwise,  $E(C_{\text{blue}})$  or  $E(C_{\text{red}})$  would be a component of size one, contradicting Statement (a). Now, by Claim 2,  $e_5$  is a pure edge, and it has the same color of  $e_4$ . Similarly,  $e_1$  is a pure edge and it has the same color of  $e_2$ . Hence,  $e_1, e_2$  are red pure edges and  $e_4, e_5$  are blue pure edges, showing that  $|E(C_{\text{blue}})| = |E(C_{\text{red}})| = 3$  and both  $C_{\text{blue}}$  and  $C_{\text{red}}$  have at most one non-pure edge.

Finally, we show Statement (c). Let  $x$  and  $y$  be the number of 3-paths and 2-paths, respectively, and  $z$  the number of edges having both colors. By Statement (a), the number of edges in  $Q$  is  $n = 3x + 2y - z = 3(x - z) + 2(y + z)$ . Since the components of  $Q_{\text{blue}}$  and  $Q_{\text{red}}$  are alternating along  $Q$ , the number of paths is even, and so  $x$  and  $y$  have the same parity. Clearly, also  $x - z$  and  $y + z$  have the same parity. Moreover, since  $n$  is odd,  $x - z$ , and consequently  $y + z$ , has to be odd. It follows that  $2(y + z)$  is congruent to 2 modulo 4 and since  $3 \equiv -1 \pmod{4}$ , we have that  $n - 2 \equiv -(x - z) \pmod{4}$ . For odd numbers, adding 2 mod 4 is the same as multiplying by  $-1 \pmod{4}$ , so  $n \equiv (x - z) \pmod{4}$ .  $\square$

For applications and frequent use, we state the specialization separately for an induced 5-cycle:

**Corollary 4.10.** *A 2-co-interval-cover of an induced 5-cycle contains two paths of two pure edges, one for each color.*

### 4.2.1 Direct applications

**Theorem 4.11** (Trotter, 1979). *For a positive integer  $n \geq 2$ ,  $\text{box}(\overline{nK_2}) = n$ .*

*Proof.* The upper bound follows directly by Theorem 4.5,  $\text{box}(\overline{nK_2}) \leq n$ . No co-interval graph can contain an induced  $2K_2$  (Lemma 4.7), hence each edges of  $nK_2$  has to be contained in a different co-interval graph,  $\text{box}(\overline{nK_2}) \geq n$ .  $\square$

Some curiosities about the above result. Theorem 4.5 implies that graphs with less than five vertices are rectangle graphs. Trotter [89] proved that  $\overline{3K_2}$  is the unique graph on 6 vertices with boxicity three. Also, notice that  $\overline{3K_2}$  is a planar graph, so the maximum boxicity of a planar graph is at least three (and at most three by [87]). Bhowmick and Chandran [9] observed that for any  $n$ , the complement of  $nK_2$  is a circular arc graph (see Figure 4.1 for a representation of  $\overline{3K_2}$ ). Hence circular arc graphs may have an arbitrarily large boxicity.

**Theorem 4.12** (Cozzens and Roberts, 1982). *For a positive integer  $n \geq 4$ ,  $\text{box}(\overline{C_n}) = \lceil \frac{n}{3} \rceil$ .*

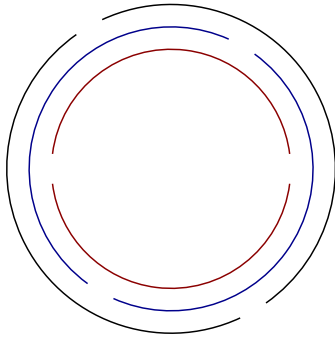

Figure 4.1: Family of circular arcs having  $\overline{3K_2}$  as intersection graph.

*Proof.* For the upper bound, observe that a co-interval-cover can be obtained by taking  $\lceil \frac{n}{3} \rceil$   $P_4$ . Hence, by Lemma 4.6,  $\text{box}(\overline{C_n}) \leq \lceil \frac{n}{3} \rceil$ .

Assume for a contradiction that  $\text{box}(\overline{C_n}) < \lceil \frac{n}{3} \rceil$  and consider a co-interval-cover of  $C_n$  of size  $\lceil \frac{n}{3} \rceil - 1$ . Then, there is a co-interval graph  $G$  in the cover with at least 4 edges, but every set of four edges in  $C_n$  contains an induced  $2K_2$ , contradicting Lemma 4.7 (a).  $\square$

The only induced  $\overline{C_n}$  that a rectangle graph can contain is  $\overline{C_5} = C_5$ . Because of the *Strong Perfect Graph Theorem* [22], we can directly generalize a result of Ahlswede and Karapetyan [2, Statement 5].

**Proposition 4.13.** *If a rectangle graph  $G$  does not contain any induced odd cycle of size  $k \geq 5$ , then  $G$  is a perfect graph. In particular,  $\theta(G) = \alpha(G)$ , and  $\chi(G) = \omega(G)$ .*

### 4.3 Boxicity of the Ramsey graph $G_{3,5}$ and the Grötzsch graph

In this section, we apply the properties of Theorem 4.9 to two notorious graphs: the unique Ramsey graph on 13 vertices with no triangles and no stable set of size five and the Grötzsch graph. These results will give an idea of the potential of our method.

#### 4.3.1 The Ramsey graph $G_{3,5}$

Let us first recall Ramsey's Theorem (see, for instance, [30, Chapter 9]): sufficiently large graphs have either a large clique or a large stable set. The Ramsey number  $R(k, l)$  is the smallest number such that every graph of order  $R(k, l)$  either has a clique of size  $k$  or a stable set of size  $l$ . By this minimality there is at least one graph of order  $R(k, l) - 1$  with maximum clique size  $k - 1$  and maximum stable set size  $l - 1$ . Such a graph is called a  $(k, l)$ -Ramsey graph.

As an example, we explain the main issues related to our interest in rectangles for  $k = 3$  and  $l = 5$ . It is well-known that  $R(3, 5) = 14$  [81] and there is only one Ramsey graph, a "circularly symmetric" graph  $G_{3,5}$  (Figure 4.2, (left)): a cycle  $Q$  on 13 vertices together with its 13 5-chords. Since it is triangle-free, it needs at least 7 cliques to cover all its vertices, and actually, 7 cliques are enough (it has a perfect matching deleting any vertex); at the same time, it has no stable set of size 5. If it were a rectangle graph, we would have:  $\nu = 4$  and  $\tau =$

7, providing a tight example of Wegner’s conjecture. Currently, the only known rectangle graph with these properties has a finite (but large and not explicitly computed) number of vertices [20].  $G_{3,5}$  also has good properties with respect to the chromatic number/clique number ratio: it is a triangle-free graph with a chromatic number of 4 (in [7] is presented a triangle-free rectangle graph on 21 vertices).

Other parameters of interest for Wegner’s conjecture are  $k = 4$  and  $l = 4$ , for which  $R(4, 4) = 18$ . The only Ramsey graph for these parameters is the Paley graph on 17 vertices  $G_{4,4}$  [81]. This graph has stability number and clique number 3, so its clique covering number is at least 6. If it were a rectangle graph, it would have  $\nu = 3$  and  $\tau = 6$ . By Proposition 4.2, it would be the smallest counterexample to Wegner’s conjecture! This is not the case: for every rectangle graph with  $\nu \leq 3$ , the inequality  $\tau \leq 5$  holds (Theorem 1.20), hence without any computation we can conclude  $\text{box}(G_{4,4}) \geq 3$ .

Computing the boxicity of  $G_{3,5}$  will not be as direct as this and we will need to use Theorem 4.9 in its full extent.

**Theorem 4.14.**  $\text{box}(G_{3,5}) = 3$ .

*Proof.* The upper bound  $\text{box}(G_{3,5}) \leq 3$  follows from Lemma 4.4 and the rectangle representation of  $G_{3,5}$  with two non-adjacent deleted vertices offered in Figure 4.2 (right).

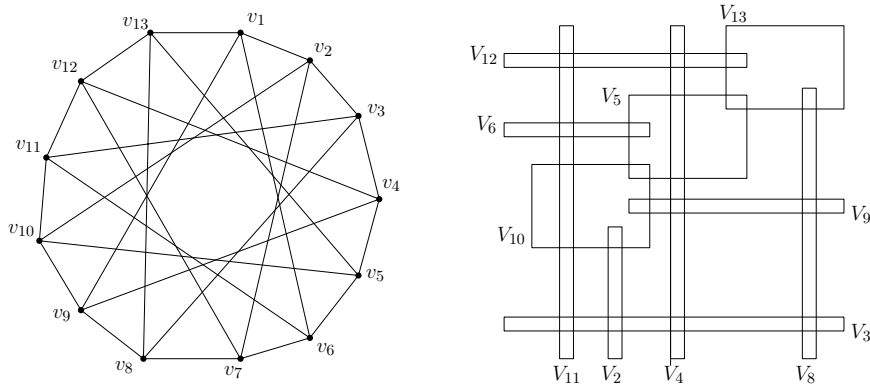

Figure 4.2:  $G_{3,5}$  where the vertices of the defining circuit  $Q$  are labelled consecutively from  $v_1$  to  $v_{13}$  (left); a family of axis-parallel rectangles realizing the intersection graph of  $G_{3,5} - \{v_1, v_7\}$  (right).

For the lower bound, assume for a contradiction that  $G_{3,5}$  is a rectangle graph. By Lemma 4.6, this means that  $G := \overline{G_{3,5}}$  has a 2-co-interval-cover. As usual, we use blue and red for the two interval graphs that cover the edges of  $G$ .

Since all chords are of the same size, two “consecutive” chords form a 4-circuit with two edges of  $Q$  (for example,  $\{v_1, v_2, v_6, v_7\}$ ). The  $2K_2$  of the complement of this 4-circuit consists of a 4-co-chord and a 6-co-chord. The set of the 13 such  $2K_2$  establishes a bijection between the 4-co-chords and the 6-co-chords of  $Q$  in  $G_{3,5}$ . Moreover, by Lemma 4.7 all these co-chords are pure edges, so the bijection is strictly between pure edges of different colors.

Since both 4 and 6 are relatively prime with 13, the 4-co-chords form 13-circuits in  $G$ , and so do the 6-co-chords, denote these circuits  $F$  and  $S$  respectively. We summarize these observations in the following claim:

**Claim.** In a 2-co-interval-cover of  $G$  each edge of  $E(F) \cup E(S)$  is pure, and there exists a color-changing bijection  $f : E(F) \rightarrow E(S)$ .

Furthermore, both  $F$  and  $S$  are  $P_4$ -inducing. Indeed, vertices at distance 2 or 3 on  $F$  and  $S$  are either sides or chords of  $G_{3,5}$ , so  $F$  and  $S$  have no 2-chords or 3-chords. Therefore Theorem 4.9 can be applied to them:

Since, by the Claim, all edges are pure and  $13 \equiv 1 \pmod{4}$ , by Theorem 4.9 the edges of  $F$  are colored alternately by 2-paths of red, 2-paths of blue edges, and one 3-path (the congruence would allow for five or more 3-paths but the number of edges in  $F$  does not). The pattern of colors in the cyclic order of  $E(F)$  is thus (by assigning blue and red to the two colors appropriately, without loss of generality)  $bbrrbbrrbbrrr$  where  $b$  stays for the blue color and  $r$  for the red color.

Now  $\{f(e) : e \in E(F)\} = E(S)$ , and by the claim, the image of each edge of  $F$  is an edge of  $S$  of a different color. Reordering the edges in the cyclic order of  $E(S)$ , we get the color pattern  $rrrbbrrrbbbb$ . So  $S$  contains 4 consecutive edges of the same color, contradicting Corollary 4.8, and finishing the proof of the theorem.  $\square$

### 4.3.2 The Grötzsch graph

Given a graph  $G = (V, E)$ , the *Mycielski operator* on  $G$  defines a graph  $M(G)$  on  $2|V| + 1$  vertices: replicate each  $v \in V$ , introducing a new vertex  $v'$ , and join it exactly to the neighbors of  $v$  (without joining  $v$  and  $v'$ ). Let  $V' := \{v' : v \in V\} \cup \{v_0\}$ , where  $v_0$  is an additional new vertex joined to all vertices of  $V'$ . Let the new edges, all incident to  $V'$ , by  $E'$ . Then the constructed graph is  $M(G) := (V \cup V', E \cup E')$ . Mycielski's goal [72] was to construct triangle-free graphs with a high chromatic number. He achieved that through the following two properties of his operator: if  $G$  is triangle-free, then so is  $M(G)$ , and  $\chi(M(G)) = \chi(G) + 1$ .

The graph  $M(C_5)$  is called the *Grötzsch graph*. The boxicity of Grötzsch graph is computed in [55], but the proof is achieved via an involved case analysis<sup>1</sup>. The short and simple proof we provide here uses essentially only the easy observations we summarized in Lemma 4.7. The way we apply these observations turned out to be general enough to be successful in further cases shown in the sequel.

**Theorem 4.15.**  $\text{box}(M(C_5)) = 3$ .

*Proof.* We follow the representation of the Grötzsch graph  $M(C_5)$  by the Mycielski construction (see Figure 4.3 (left)). The right figure represents  $M(C_5) - v_0$  as the intersection graph of a set of axis-parallel rectangles. By Lemma 4.4,  $\text{box}(G) \leq \text{box}(G - v) + 1 \leq 2 + 1 = 3$ .

For the lower bound, assume by contradiction that  $\text{box}(M(C_5)) \leq 2$ . By Lemma 4.6, this implies that  $G := \overline{M(C_5)}$  can be covered by the edges of two co-interval graphs, with red edges and blue edges.

By the Mycielski construction starting with the induced cycle  $(v_1, \dots, v_5)$ , denote  $Q$  its complement. The vertices  $v_i$  and  $v'_i$  are non-adjacent in  $M(C_5)$ , and have the same neighbors  $v_{i-1}, v_{i+1}$ , so the edges  $v_i v'_i, v_{i-1} v_{i+1} \pmod{5}$  form a  $2K_2$  in  $G$ . Then by Lemma 4.7 all edges of the induced 5-cycle  $Q$ , are pure, and then by Corollary 4.10 (by choosing the colors appropriately), it consists of a pure red path of length 3 and a pure blue path of length 2. In each of the detected  $2K_2$  the edge  $v_i v'_i$  has the color which is different from that of  $v_{i-1} v_{i+1} \in Q$ . Therefore, we can suppose without loss of generality that  $v_1 v_3, v_1 v_4$  are blue

<sup>1</sup>This proof is unpublished, we thank the author of [55] for sharing it with us.

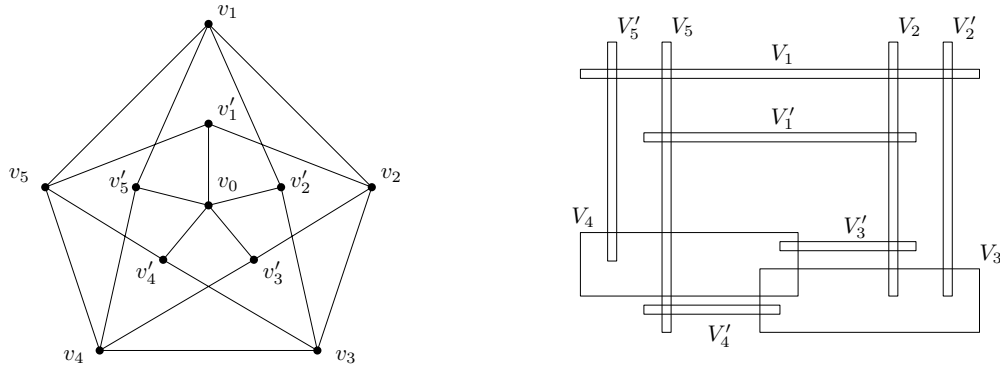

Figure 4.3: Grötzsch graph  $M(C_5)$ , where the vertices of  $C_5$  are  $v_1, \dots, v_5$ , and then the notation follows the Mycielski construction (left); a family of axis-parallel rectangles realizing the intersection graph of  $M(C_5) - v_0$  (right).

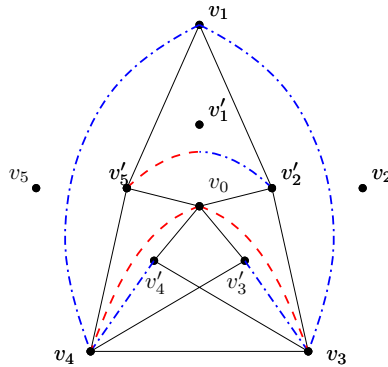

Figure 4.4: The continuous black lines are edges of the Grötzsch graph that play a role for the three induced 5-cycle with a common edge  $v_3v_4$  in the proof. The dotted lines represent red edges and the dash-dotted ones blue edges. The contradiction appears when it comes to color edge  $v'_2v'_5$ .

and the other edges of  $Q$  are red, and therefore  $v_2v'_2, v_5v'_5$  are red, and  $v_1v'_1, v_3v'_3$  and  $v_4v'_4$  are blue.

**Claim.** Both  $v_0v_3$  and  $v_0v_4$  are red.

Indeed, by Corollary 4.10 the induced 5-cycle  $(v_0, v_3, v'_3, v'_4, v_4)$  has also two consecutive purely red edges. Since the edges  $v_3v'_3$  and  $v_4v'_4$  are blue the only possibility for two consecutive red edges is  $v_0v_3$  and  $v_0v_4$ , as claimed.

Now the contradiction appears: observe that the induced 5-cycle  $v_1v'_2v_3v_4v'_5$  and  $v_0v'_2v_3v_4v'_5$  differ only in one vertex, in particular they have the edge  $v'_2v'_5$  in common, moreover this edge is the middle edge of an uncolored sequence of three edges in both. The other two edges have both already been colored blue in the former circuit (edges  $v_1v_3$  and  $v_1v_4$  by the above coloring of  $Q$ ), and red in the latter one (edges  $v_0v_3$  and  $v_0v_4$  by the claim). So by Corollary 4.10 there is a pure sequence of the other color in both, and  $v'_2v'_5$ , as the middle edge of both must be included in it: it must be red in the former circuit and blue in the latter, a contradiction that finishes the proof of the theorem (see Figure 4.4).  $\square$

In 1973, Chvátal [24] proved that the smallest 4-chromatic triangle-free graph has 11



vertices and is unique. This graph is the Grötzsch graph. Since in Theorem 4.15 we showed that Grötzsch graph is not a rectangle graph, a question naturally arises:

*What is the size of the smallest triangle-free rectangle graph with a chromatic number of 4?*

In joint work with Alexandre Talon, we design an algorithm that, using the properties of 2-co-interval-covers presented in Lemma 4.7 and Theorem 4.9, can efficiently recognize rectangle graphs with a small order (approximately 20).

Through a computer search among triangle-free 4-critical graphs of order 12 to 15 (a graph is  $k$ -critical if it has chromatic number  $k$  and each of its proper induced subgraphs has a smaller chromatic number), we established the following result.

**Theorem 4.16.** *Every triangle-free rectangle graph with at most 14 vertices is 3-colorable. Moreover, there exist examples with 15 vertices that are not 3-colorable.*

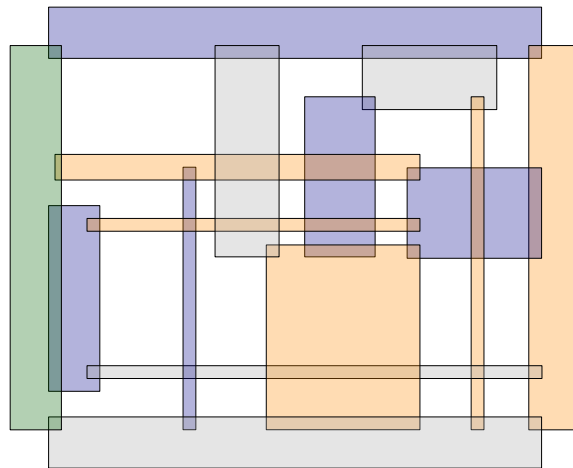

Figure 4.5: A triangle-free family of 15 axis-parallel rectangles with chromatic number 4.

A direct consequence of Theorem 4.16 is that some well-known graphs with small order are not rectangle graphs. For example, Chvátal graph [25] (the smallest triangle-free, 4-chromatic, 4-regular graph) is not.

## 4.4 Boxicity of the Kneser graph $K(n, 2)$

The Petersen graph is probably one of the most famous graphs in Graph Theory. It owes its popularity to its versatility in serving as a primary example or counterexample for numerous conjectures. Initially, it was constructed by Petersen [80]<sup>2</sup> to show that there are cubic, bridgeless graphs that have chromatic index 4.

The Petersen graph is edge and vertex-transitive: it is  $\overline{L(K_5)}$ . Since we extensively use this relationship, we exhibit a bijection in Figure 4.6 between the edges of  $K_5$  and the vertices of the Petersen graph, where two edges of  $K_5$  are incident if and only if the two corresponding vertices of the Petersen graph are non-adjacent.

<sup>2</sup>The same graph already appeared in a paper of Kempe about ten years earlier[57].

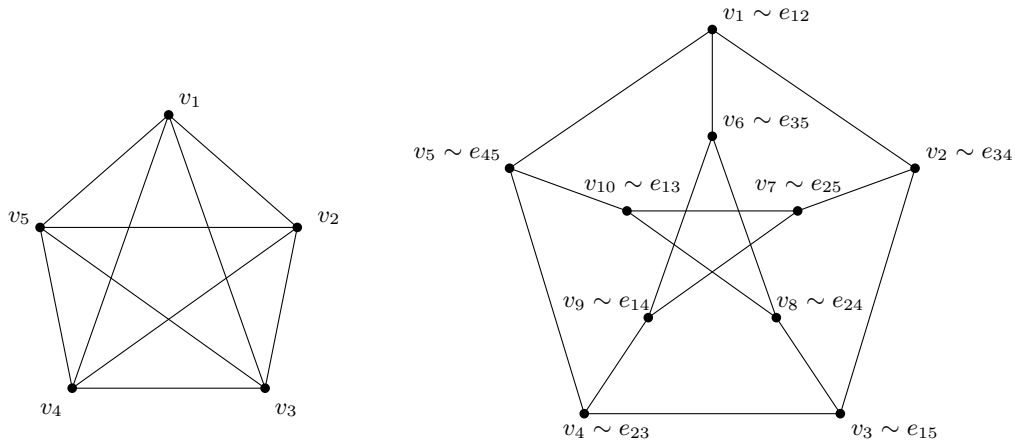

Figure 4.6: (left)  $K_5$ , the complete graph on five vertices, (right)  $\overline{L(K_5)}$ , the Petersen graph. The correspondences between the edges of  $K_5$  and the vertices of  $L(K_5)$  are remarked in the labels of the drawing on the right.

Henning Bruhn [12] wrote that “calculating the boxicity is not an easy task: try the Petersen graph”. To the best of our knowledge, the boxicity of the Petersen graph was not yet established, so we took the challenge: in this section, we show that the boxicity of the Petersen graph is three. Moreover, our approach easily extends to general complements of line graphs, in particular to  $\overline{L(K_n)}$  for any  $n \geq 2$ . Hence, instead of limiting ourselves to the Petersen graph, we study the boxicity of  $\overline{L(K_n)}$ . This graph corresponds to the Kneser graph  $K(n, 2)$ .

Our method consists again of studying the co-interval subgraphs of  $L(K_n)$  directly. We then show that  $n - 3$  of these cannot cover all of its edges, settling a conjecture stated in [14].

Given  $n$  intervals in  $\mathbb{R}$ , we order them in a non-decreasing order  $\sigma = I_1 \dots I_n$  of their right end-points. For the co-interval graph  $G = (V, E)$ , and  $V = \{v_1, \dots, v_n\}$ , where  $v_i$  corresponds to  $I_i$  ( $i = 1, \dots, n$ ) and two vertices are joined if and only if the corresponding intervals are disjoint (the complement of their intersection graph), we have then the following:

Orienting the edges of  $G$  from the vertices of smaller index towards those of larger index, we have:

$$\text{if } i > j, \text{ then } N^+(v_i) \subseteq N^+(v_j), \tag{4.1}$$

where the *out-neighborhood* of a vertex  $v_l \in V(G)$  is the set  $N^+(v_l) := \{v_m : v_l v_m \in E(G), l < m\}$ .

By necessity, one realizes with a simple inductive proof, that this “chain property” actually *characterizes* co-interval graphs, as the reader can also easily check. We found the first clear, explicit statement of this in Olariu’s paper [75]:

**Lemma 4.17.** *Let  $G$  be a simple undirected graph. Then  $G = (V, E)$  is a co-interval graph if and only if  $V$  has an order  $(v_1, \dots, v_n)$  so that orienting the edges from the vertices of smaller index towards those of larger index (4.1) holds.*

Inspired by this characterization, we can define co-interval subgraphs of an arbitrary graph. Let  $G = (V, E)$  be a graph and  $\sigma$  an ordering of  $V(G)$ . We define then the graph

$G^\sigma = (V, E^\sigma)$ ,  $E^\sigma := E_1 \cup E_2 \cup \dots \cup E_{n-1} \subseteq E$  as follow: let  $V_0 := V$ ,  $V_i := V_{i-1} \cap N_G(v_i)$  for  $1 \leq i \leq n$ , and  $E_i$  be the set of edges from  $v_i$  to  $V_i$ .

In turn, we denote by  $\vec{G}^\sigma = (V, \vec{E}^\sigma)$  the digraph we get by orienting the edges of  $G^\sigma$  from its endpoint of smaller index to the one with larger index. Clearly  $N^+(v_i) = V_i$ , so by our construction (4.1) is satisfied, and then Lemma 4.17 immediately implies the first part of the following corollary. The converse also follows by considering the ordering  $\sigma$  satisfying (4.1) that exists by the reverse implication of Lemma 4.17:

**Corollary 4.18.** *Let  $G = (V, E)$  be a simple undirected graph. Then for any ordering  $\sigma$  of  $V$ ,  $G^\sigma$  is a co-interval subgraph of  $G$ . Conversely, any inclusionwise maximal co-interval subgraph of  $G$  is  $G^\sigma$  for some ordering  $\sigma$  of  $V$ .*

Note that a partial ordering  $v_1, \dots, v_i$  is already sufficient for defining  $V_i$  the set that is becoming eventually  $N^+(v_i)$ , and therefore we will anticipate the notation  $N^+(v_i)$  and use it already when the partial ordering is defined.

Note that *in the chain of (4.1), only the first at most  $\Delta := \Delta_{\max}(G)$  sets are non-empty!* Indeed, suppose  $N^+(v_i) \neq \emptyset$  for  $i \geq \Delta + 1$ , let  $x \in N^+(v_i)$ . Then by (4.1),  $x$  is also in the neighborhood of all previous vertices, that is,  $N_G(x) \supseteq \{v_1, \dots, v_{\Delta+1}\}$ , contradicting that  $\Delta$  is the maximum degree. The out-degrees of the  $v_i$  ( $i = 1, \dots, n$ ) are decreasing from  $d(v_1)$  to 0.

Given a graph  $G$ , an *interval completion* of  $G$  is an interval spanning supergraph of  $G$ , that is, an interval graph with  $V(G)$  as vertex set and a superset of  $E(G)$  as edge set. Computing the minimum interval completions is an  $\mathcal{NP}$ -hard problem [43], and by complementation, it is equivalent to the maximum co-interval subgraph. However, the properties of line graphs enable us to solve the problem in polynomial time and also to compute the boxicity when it is below an arbitrarily fixed bound (see [15]).

The interval completion problem for a graph is equivalent, by complementation, to finding a co-interval graph in the complement of the graph. The following lemma makes it easier to encounter such subgraphs, and in particular for line graphs of complete graphs, for which only the special case  $|N| = 2$  plays a role.

**Lemma 4.19.** *Let  $G = (V, E)$  be a simple graph,  $\sigma_i = (v_1, v_2, \dots, v_i)$   $i \in \mathbb{N}, 1 \leq i < n$ , the starting sequence of an ordering of  $V$ , and  $N$  the set of common neighbors of  $V_i := \{v_1, v_2, \dots, v_i\}$  in  $V \setminus V_i$ . Then for every maximal co-interval subgraph  $G^\sigma$  with  $\sigma$  continuing  $\sigma_i$ ,  $\sigma_i$  is immediately followed by the entire set of common neighbors in  $V \setminus V_i$  of all elements of  $N$ , in arbitrary order. If  $|N| = 2$ , then there are at most two such maximal co-interval graphs.*

Denote the common neighbors in  $V \setminus V_i$  of all elements of  $N$  by  $N'$ , and note that  $N' \subseteq V \setminus V_i$  is exactly the set of elements electable to be added to  $\sigma$  as  $v_{i+1}$  so that  $N^+(v_{i+1}) = N^+(v_i)$ . In particular,  $N' \cap N = \emptyset$ , since each  $v \in N$  is not in  $N(v)$  and therefore it is not in  $N'$ . It is therefore false – while tempting – to think that once a few elements of  $\delta(a) \subseteq E(K_n)$  ( $a \in V(K_n)$ ) are listed in  $\sigma$ , those that are not yet there, are in  $N'$ .

*Proof.* If  $\sigma_i$  is not immediately followed by the vertices of  $N'$ , move all vertices of  $N'$ . Clearly, each set of neighbors in (4.1) is replaced by a superset (at least once a proper superset), and therefore the edge set of  $G^\sigma$  increases, contradicting maximality, and the first assertion is proved.

If  $|N| = 2$ , denote  $x$  and  $y$  its two elements, and  $N_{xy}, N_x, N_y$  be the vertices in  $V \setminus V_i$  adjacent to both, or only  $x$ , only  $y$  respectively. By the already proven first part, then  $\sigma'$

is immediately followed by  $N_{xy}$ , and then for maximality, either an element of  $N_x$  or an element of  $N_y$  should follow, unless both are empty. Applying again the already proven first part, then the entire  $N_x$  or the entire  $N_y$  must follow, presenting the two co-interval graphs.  $\square$

Clearly,  $\text{box}(\overline{L(K_2)}) = 0$ ,  $\text{box}(\overline{L(K_3)}) = 1$ , however  $\text{box}(\overline{L(K_4)}) = 1$ , as  $\overline{L(K_4)}$  is a perfect matching with three edges.

We will now switch to a higher gear, settling the interval completion problem and boxicity of larger complements of line graphs. For each of these, we will start with Corollary 4.18. For an illustration, note that  $\text{box}(\overline{L(K_4)}) = 1$  can also be seen by considering in  $L(K_4)$  the order  $v_1, v_2, v_3, v_4$ , where  $v_1, v_2$  are edges of  $K_4$  forming a matching,  $v_3, v_4$  is another matching, altogether covering  $4 + 4 + 2 + 2$  different edges, that is, all edges of  $L(K_4)$ . This will turn out to be the *only* exception to  $\text{box}(\overline{L(K_n)}) = n - 2$  for  $n \geq 3$ .

A solution necessitates, already for a small value of  $n$ , refined knowledge about interval completions of complements of line graphs (including the Petersen graph), that is, about co-interval subgraphs of line graphs. The following lemma establishes that  $L(K_n)$  has three essentially different maximal co-interval subgraphs.

In order to describe these subgraphs, it will be helpful to borrow notation from  $K_n$  for some *edge sets* in  $L(K_n)$ : for  $v \in V(K_n)$ ,  $Q_v$  will denote the set of  $\frac{(n-1)(n-2)}{2}$  edges of the clique formed in  $L(K_n)$  by the  $n - 1$  edges of  $\delta(v) \subseteq E(K_n)$  as vertices of  $L(K_n)$ ; for an edge  $e = uv \in E(K_n)$ ,  $\delta_{uv}$  denotes the set of edges  $ef \in E(L(K_n))$ , where  $f \in V(L(K_n))$  is incident to  $u$  or  $v$  in  $K_n$ , that is,  $\delta_{uv}$  is the star of center  $e = uv \in V(L(K_n))$  in  $L(K_n)$ ,  $|\delta_{uv}| = 2(n - 2)$ ; the set  $\delta_{uv^-}$  consists only of the edges  $ef$ , where  $f$  is incident to  $u$  in  $K_n$ ,  $|\delta_{uv^-}| = n - 2$ ; finally, for any  $U \subseteq V(K_n)$ ,  $K_U$  is the edge set of the line graph of the complete subgraph on  $U$  (isomorphic to  $L(K_{|U|})$ ), and  $K_{u,v,w^-}$  contains the two edges in  $L(K_n)$  joining  $uv$  and  $uw$ , the one joining  $vu$  and  $vw$ , but not the third edge of  $K_{\{u,v,w\}}$ ,  $|K_{u,v,w^-}| = 2$ .

**Lemma 4.20.** *Let  $n \geq 5$ . Then the edge set of any co-interval subgraph of  $L(K_n)$  is a subset of one of the following sets, forming co-interval graphs  $G^\sigma = (V, E^\sigma)$  for an appropriate ordering  $\sigma$ .*

(a)  $H = (V, E_{a,b,c,b',c'})$  for five different vertices  $a, b, c, b', c' \in V(K_n)$ ,

$$E_{a,b,c,b',c'} = Q_a \cup \delta_{ab} \cup \delta_{ac} \cup K_{\{a,b,b'\}} \cup K_{\{a,c,c'\}}, |E_{a,b,c,b',c'}| = \frac{(n+2)(n-1)}{2}.$$

(b)  $H = (V, E_{a,b,c,d})$  for four different vertices  $a, b, c, d \in V(K_n)$ ,

$$E_{a,b,c,d} = \delta_{ab} \cup \delta_{ad} \cup K_{\{a,b,c,d\}}, |E_{a,b,c,d}| = 4(n-1).$$

(c)  $H = (V, F_{a,b,c,d})$  for four different vertices  $a, b, c, d \in V(K_n)$ ,

$$F_{a,b,c,d} = \delta_{ab} \cup \delta_{ad} \cup \delta_{ac^-} \cup K_{\{a,b,c\}} \cup K_{\{a,b,d\}} \cup K_{d,a,c^-} \cup K_{c,b,d^-},$$

or the same edge set replacing  $\delta_{ad}$  by  $\delta_{bc}$ ,  $|F_{a,b,c,d}| = 5(n-2)$ .

*Proof.* Consider an ordering  $\sigma$  so that  $E^\sigma$  is inclusionwise maximal, and let us prove that  $E^\sigma$  has one of the claimed forms. Let  $v_1 := ab \in E(K_n)$ , and  $i$  be the first index such that  $v_i$ , as an edge of  $K_n$ , is not incident to  $a$ . If there is no such a  $v_i$ , when we define  $i := \infty$ .

*Case 1:  $i \geq 4$*

We can suppose  $v_2$  and  $v_3$  are two edges in  $K_n$  incident to the same vertex  $a$  (Figure 4.7).

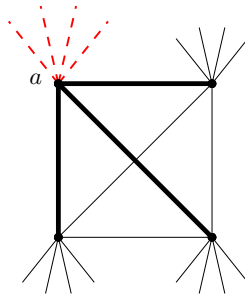

Figure 4.7: The edges of  $V(K_n)$  that can be contained in  $\sigma$  in Case 1. The edges with fat lines are the ones corresponding to  $v_1, v_2, v_3$ , and the ones with dashed red lines correspond to the vertices in  $N^+(v_3)$ .

**Claim.**  $i = n - 2$  or  $i = n - 3$ , and in the latter case there exists  $\sigma'$  with  $i = n - 2$  and  $G^{\sigma'} = G^\sigma$ .

Indeed,  $i \leq n - 2$ , since  $i > n - 2$  would imply  $N^+(v_{n-3})$  be equal to the set of edges incident to  $a$  not participating in the ordering  $v_1, \dots, v_{n-3}$ ; denoting the other endpoints of these two edges by  $c'$  and  $c$ , Lemma 4.19 obliges  $v_{n-2} = c'c$ , and  $i = n - 2$ . Similarly, if  $i < n - 2$ , denote again  $v_i := c'c$ : then  $N^+(v_i) = \{ac, ac'\}$ , and by Lemma 4.19 again, the edges different from  $v_1, \dots, v_{i-1}$  and from  $ac, ac'$  incident to  $a$  must be the following  $n - i - 2 > 0$  elements  $v_{i+1}, \dots, v_{n-2}$  of  $\sigma$ . However, if  $n - i - 2 = 1$ , then postponing  $v_i$  after these, results in a proper superset of  $E^\sigma$ , contradicting maximality; if  $n - i - 2 = 1$  then postponing  $v_i$  after  $v_{n-2}$  we get an ordering  $\sigma'$  with  $G^{\sigma'} = G^\sigma$ , finishing the proof of the claim.

According to the Claim, we can suppose  $i = n - 2$  for finishing Case 1. Applying Lemma 4.19 once more to  $N^+(v_{n-2}) = \{ac', ac\}$  our only possible choice is to finish the construction of  $\sigma$  by adding the remaining neighbors of  $ac \in V(L(K_n))$  in arbitrary order (after possibly interchanging the notations for  $c$  and  $c'$ ).

Now besides the edges of  $Q_a \subseteq E(L(K_n))$  we get  $n - 2$  more edges of  $\delta_{ba-}$ ; denoting  $b'$  the other endpoint of  $v_2$  as an edge of  $K_n$ ,  $|N^+(v_2)|$  contains  $\{bb'\}$  in addition to the edges in  $Q_a$  ( $bb'$  is the unique additional edge of  $K_{\{a,b,b'\}}$  compared to  $Q_a \cup \delta_{ab}$ ); when we add  $v_{n-2}$  and the neighbors of  $ac \in V(L(K_n))$ , we add  $1 + n - 2$  edges, arriving at  $E_{a,b,c,b',c'}$  of size:

$$\frac{(n-1)(n-2)}{2} + n - 2 + 1 + 1 + n - 2 = \frac{(n+2)(n-1)}{2}$$

*Case 2:  $i = 3$*

We can suppose  $v_2 = ac \in E(K_n)$  for some  $c \in V(K_n)$  different of  $a$  and  $b$ . Once we choose  $v_3 \in E(K_n)$ , there are three possible cases: either  $v_1, v_2, v_3$  form the three edges of a triangle of  $K_n$ , or of a  $P_4$ , or of a  $P_3 + K_2$  (see Figure 4.8).

*Case 2.1:  $v_1, v_2, v_3$  form the three edges of a triangle of  $K_n$  (Figure 4.8 (left)).*

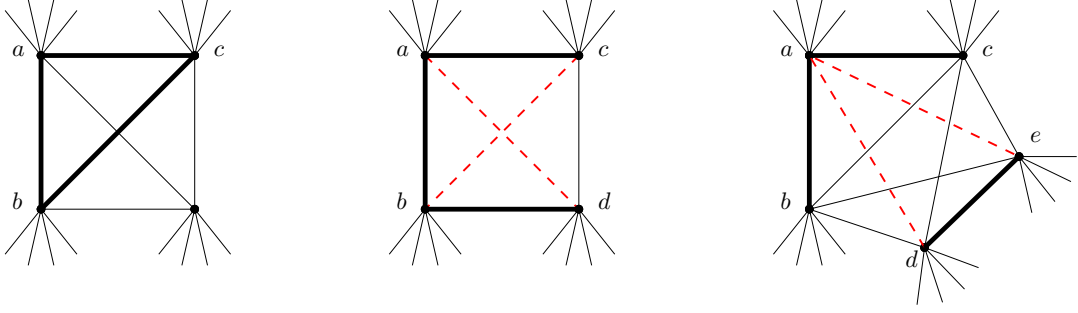

Figure 4.8: The edges of  $V(K_n)$  that can be contained in  $\sigma$  in Case 2. The edges with fat lines are the ones corresponding to  $v_1, v_2, v_3$ , and the ones with dashed red lines correspond to the vertices in  $N^+(v_3)$ .

Then  $v_1, v_2$  and  $v_3$  have no common neighbors, so any completion of the order starting with  $v_1, v_2$  will be contained in  $\delta_{ab} \cup \delta_{ac}$ , a subset of (a), (b) or (c), contradicting maximality.

*Case 2.2:*  $v_1, v_2, v_3$  form the three edges of a  $P_4$  (Figure 4.8 (center)).

Then  $v_3 = bd$  (or, equivalently  $v_3 = cd$ ), where  $d \in V(K_n)$  is different from  $a, b, c$ . The set of common neighbors of  $v_1, v_2, v_3$  is  $\{bc, ad\}$ , and by Lemma 4.19,  $v_4 = cd$  (or, equivalently  $v_4 = bd$ , if  $v_3 = cd$ ), and we can either continue the construction of an order  $\sigma$  with all neighbors in  $L(K_n)$  of  $bc$ , or all neighbors of  $ad$ , arriving respectively at the following two co-interval graphs:

$$\delta_{ab} \cup \delta_{ad} \cup \delta_{ac^-} \cup K_{\{a,b,c\}} \cup K_{\{a,b,d\}} \cup K_{\{d,a,c^-\}} \cup K_{\{c,b,d^-\}},$$

$$\delta_{ab} \cup \delta_{bc} \cup \delta_{ac^-} \cup K_{\{a,b,c\}} \cup K_{\{a,b,d\}} \cup K_{\{d,a,c^-\}} \cup K_{\{c,b,d^-\}}.$$

Hence, Case 2.2 leads to co-interval graphs in the form of (c). We can now calculate  $|F_{\{a,b,c,d\}}|$  for instance by counting the number of new edges of  $G^\sigma$  after each  $v_i$ :  $|N^+(v_1)| = 2(n-2)$ ;  $|N^+(v_2)| = n-2$  since  $N^+(v_2)$  consists of  $n-3$  the edges in  $K_n$  incident to  $a$ , without counting  $ab$ , and of  $bc \in V(L(K_n))$ ;  $|N^+(v_3)| = |N^+(v_4)| = 2$ ; then we add  $2(n-4)$  edges in  $L(K_n)$  with an out-neighborhood of cardinality 1, after which the out-neighborhoods are empty, and in total we added  $3(n-2) + 4 + 2(n-4) = 5(n-2)$  edges.

*Case 2.3:*  $v_1, v_2, v_3$  form the three edges of a  $P_3 + K_2$  (Figure 4.8 (right)).

Then  $v_3 = de$ , where  $d, e \in V(K_n)$  is different from  $a, b, c$ . In this case  $N^+(v_3) = \{ad, ae\}$ , and the analysis done in the Claim holds again, implying that  $i = n-2$ . If  $n = 5$ , we get graph (a), otherwise the maximality is violated.

*Case 3:*  $i = 2$

Then denote  $c$  and  $d$  the two endpoints of  $v_2 \in E(K_n)$ , different from  $a$ . If  $c$ , or  $d$ , coincides with  $b$ , then interchange  $a$  and  $b$ , obtaining  $i > 2$ . Otherwise,  $N^+(v_2) = N_{L(K_n)}(v_1) \cap N_{L(K_n)}(v_2) = \{ad, db, bc, ca\}$ , and any choice of  $v_3$  corresponding to an edge in  $K_n$  incident to  $a, b, c$ , or  $d$  will lead to  $|N^+(v_3)| = 2$  (see Figure 4.9). There are two non-equivalent ways of continuing then:

*Case 3.1:*  $v_3 = ac$  (interchanging notations,  $ac$  can be any of the four vertices of  $N^+(v_2)$ ).

Then by Lemma 4.19  $v_4 = bd$  and then the size of the out-neighborhood decreases to 1, and its unique edge can be supposed (by symmetry) to be  $ad$ . Observing that besides  $\delta_{ab} \cup \delta_{ad}$

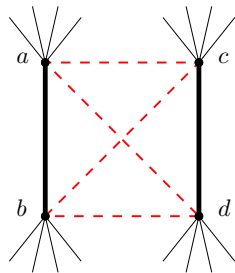

Figure 4.9: The edges of  $V(K_n)$  that can be contained in  $\sigma$  in Case 3. The edges with fat lines are the ones corresponding to  $v_1$  and  $v_2$ , and the ones with dashed red lines correspond to the vertices in  $N^+(v_2)$ .

only the edges of  $K_{\{a,b,c,d\}}$  are covered, we get that  $E^\sigma = E_{a,b,c,d} = \delta_{ab} \cup \delta_{ad} \cup K_{\{a,b,c,d\}}$ , and has  $2(n-4) + 2(n-4) + 12 = 4(n-1)$  elements.

*Case 3.2:*  $v_3$  is an edge of  $K_n$  incident to  $a$  different from  $ac$  and  $ad$  (interchanging notations,  $v_3$  can be any edge incident to  $b, c$ , or  $d$  not in  $N^+(v_2)$ ).

Then  $N^+(v_3) = \{ac, ad\}$ . By Lemma 4.19 the rest (besides  $ac, ad$ ) of the edges incident to  $a$ , and  $cd$  follow then in  $\sigma$  in arbitrary order, followed by the edges having then only one out-neighbors:  $\delta_{ad}$  and  $ac$ , providing again the set (c). □

Consider  $G$  a maximal co-interval subgraph of  $L(K_n)$ , we say that  $E(G)$  is of type (a), (b), or (c) if its edge set corresponds to the set in case (a), (b), or (c) of Lemma 4.20.

**Theorem 4.21.**  $\text{box}(\overline{L(K_n)}) = n - 2$  if  $n \geq 5$  or  $2 \leq n \leq 3$ , and  $\text{box}(\overline{L(K_n)}) = n - 3$  if  $n = 4$ .

In the following proofs, we denote the vertices of  $V(K_n)$  by  $v_1, v_2, \dots, v_n$ . We start by showing the upper bound. This result, but with a different proof, also appeared in [14].

**Lemma 4.22.**  $\text{box}(\overline{L(K_n)}) \leq n - 2$  if  $n \geq 3$ .

*Proof.* By Lemma 4.6, it is enough to exhibit an  $(n-2)$ -co-interval-cover of  $L(K_n)$ . For  $i \in [n-2]$ , let  $G_i = (V, E_i)$  be a co-interval subgraph of  $L(K_n)$  with edge set of type (a),  $E_i \supset Q_{v_i} \cup \delta_{v_i v_{n-1}} \cup \delta_{v_i v_n}$ . We show that  $\{E_i\}_{i \in [n-2]}$  covers  $E(L(K_n))$ :

Observe that  $E(L(K_n)) = \bigcup_{v \in V(K_n)} Q_v$ . For  $i \in [n-2]$ , we have  $Q_{v_i} \subset E_i$  by definition. Moreover,  $\delta_{v_{n-1} v_n}$  is covered since for  $i \in [n-2]$ , the edges  $\{v_i v_{n-1}, v_{n-1} v_n\}$  and  $\{v_i v_n, v_{n-1} v_n\}$  are contained in  $\delta_{v_i v_{n-1}}$  and  $\delta_{v_i v_n}$ , respectively. Hence, also the edge sets  $Q_{v_{n-1}} \subset \bigcup_{i \in [n], i \neq n-1} \delta_{v_i v_{n-1}}$  and  $Q_{v_n} \subset \bigcup_{i \in [n-1]} \delta_{v_i v_n}$  are covered, concluding the proof. □

Although the growth of the number of edges is quadratic in case (a), while in (b) and (c) is only linear, the three numbers are comparable for small values of  $n$ . For this reason, the arguments to show the lower bound in Theorem 4.21 for  $n \leq 6$  and  $n \geq 7$  are slightly different. For simplicity, we prove the particular cases  $n = 5$  and  $n = 6$  before proving Theorem 4.21.

**Fact 4.23.** Let  $a, b, c, d \in V(K_n)$ ,  $a \neq b$ , and  $c \neq d$ . Then  $\delta_{ab} \cap \delta_{cd} \neq \emptyset$  if and only if  $\{a, b\} \cap \{c, d\} \neq \emptyset$ .

**Theorem 4.24.**  $\text{box}(\overline{L(K_5)}) = 3$ .

*Proof.* The upper bound follows directly by Lemma 4.22, so we focus on the lower bound. Assume for a contradiction that  $\text{box}(\overline{L(K_5)}) \leq 2$  and let  $E_1$  and  $E_2$  be a 2-co-interval-cover of  $L(K_5)$ . We can assume that  $(V, E_1)$  and  $(V, E_2)$  are maximal co-interval subgraphs of  $L(K_5)$ .

**Claim.**  $|E_1 \cap E_2| \geq 1$ .

Indeed, by Lemma 4.20, for  $i \in \{1, 2\}$  there are three distinct vertices  $a_i, b_i, c_i \in V(K_5)$  such that  $\delta_{a_i b_i} \cup \delta_{a_i c_i} \subseteq E_i$ . If one of the pairs in  $\{\{a_1, b_1\}, \{a_1, c_1\}\}$  has a non-empty intersection with one of the pairs in  $\{\{a_2, b_2\}, \{a_2, c_2\}\}$ , we have the claimed property by Fact 4.23. Otherwise, the six vertices are distinct, but this is impossible since  $|V(K_5)| = 5$ .

By Lemma 4.20,  $E_1$  and  $E_2$  have either 14 (Case (a)), 15 (Case (c)), or 16 edges (Case (b)). Since  $|E(L(K_5))| = 5 \binom{4}{2} = 30$  and  $E_1, E_2$  have an edge in common, at least one of  $E_1$  and  $E_2$  has 16 edges, say  $E_1$ , and  $|E_2| \geq 15$ . So,  $E_1$  is of type (b), and  $E_2$  is of type (b) or (c). In both cases, there are two sets of four distinct vertices in  $V(K_5)$  defining the edge set of  $E_1$  and  $E_2$ . Since  $|V(K_5)| = 5$ , these two sets have at least three common vertices, say  $\{a, b, c\}$ . Then, the three edges in  $K_{a,b,c}$  are contained in  $E_1$  and at least 2 of them are in  $E_2$ , if  $E_2$  is of type (c), or all of them, if it is of type (b). Hence, either  $|E_2| = 15$  and  $|E_1 \cap E_2| \geq 2$ , or  $|E_2| = 16$  and  $|E_1 \cap E_2| \geq 3$ . Either way,  $|E_1| + |E_2| - |E_1 \cap E_2| < 30$  contradicting that  $\{E_1, E_2\}$  is a co-interval-cover of  $E(L(K_5))$ .  $\square$

**Theorem 4.25.**  $\text{box}(\overline{L(K_6)}) = 4$ .

*Proof.* By Lemma 4.22,  $\text{box}(\overline{L(K_6)}) \leq 4$ . For the upper bound, assume for a contradiction that  $\text{box}(\overline{L(K_6)}) \leq 3$  and let  $\{E_1, E_2, E_3\}$  be a 3-co-interval-cover of  $L(K_6)$ . We can assume that  $(V, E_1)$ ,  $(V, E_2)$ , and  $(V, E_3)$  are maximal co-interval subgraphs of  $L(K_5)$ .

By Lemma 4.20,  $|E_i| = 20$  (no matter if it is of type (a), (b), or (c)) and there are three distinct vertices  $a_i, b_i, c_i \in V(K_6)$  such that  $\delta_{a_i b_i} \cup \delta_{a_i c_i} \subseteq E_i$ . Since  $|E(L(K_6))| = 6 \binom{5}{2} = 60$ ,  $E_1, E_2$  and  $E_3$  are pairwise disjoint. Then,  $\delta_{a_i b_i} \cap \delta_{a_j b_j}$ ,  $\delta_{a_i b_i} \cap \delta_{a_j c_j}$ , and  $\delta_{a_i c_i} \cap \delta_{a_j c_j}$  are empty for all  $i, j \in [3]$ ,  $i \neq j$  and so, by Fact 4.23, the nine vertices in  $\{a_i, b_i, c_i\}_{i \in [3]}$  are all distinct, a contradiction since  $|V(K_6)| = 6$ .  $\square$

*Proof of Theorem 4.21.* Clearly,  $\text{box}(\overline{L(K_2)}) = 0$ ,  $\text{box}(\overline{L(K_3)}) = 1$ , and  $\text{box}(\overline{L(K_4)}) = 1$ . The cases  $n = 5$  and  $n = 6$  are proved in Theorems 4.24 and 4.25, so we can assume  $n \geq 7$ . Once more, the upper bound follows from Lemma 4.22, so we just prove the lower bound.

Assume for a contradiction that  $\text{box}(\overline{L(K_n)}) \leq n - 3$  and let  $\{E_i\}_{i \in [n-3]}$  be an  $(n - 3)$ -co-interval-cover of  $L(K_n)$ . We can assume that  $\{(V, E_i)\}_{i \in [n-3]}$  are maximal co-interval subgraphs of  $L(K_n)$ .

First, observe that *at least  $n - 4$  of the edge sets in the cover are of type (a)*. Indeed, if there are at most  $n - 5$  edge sets of type (a), then the number of edges in the cover is bounded by

$$(n - 5) \frac{(n + 2)(n - 1)}{2} + \max\{10(n - 2), 8(n - 1), 9n - 14\}$$

quantity that, for  $n \geq 7$ , is strictly smaller than  $|E(L(K_n))| = n \binom{n-1}{2}$ .

Therefore, the only cases to consider are: the cover contains  $n - 3$  edge set of type (a), or it contains  $n - 4$  edge sets of type (a) and one edge set of type (b) or (c).

*Case 1: all edge sets are of type (a).*



For all  $i \in [n-3]$ ,  $E_i \supset Q_{a_i} \cup \delta_{a_i, b_i} \cup \delta_{a_i, c_i}$  for distinct  $a_i, b_i, c_i \in V(K_n)$ . We reach a contradiction by showing that for any assignment of  $\{(a_i, b_i, c_i)\}_{i \in [n-3]}$ , the number of edges in  $\bigcup_{i \in [n-3]} E_i$  is strictly smaller than  $|E(L(K_n))|$ . Clearly, this is the case when the number of edges that appear in at least two of the sets  $\{E_i\}_{i \in [n-3]}$  is strictly larger than

$$(n-3) \frac{(n+2)(n-1)}{2} - \frac{n(n-1)(n-2)}{2} = \frac{(n-1)(n-6)}{2}.$$

The edge set  $Q_{a_i}$  has  $\frac{(n-1)(n-2)}{2} > \frac{(n-1)(n-6)}{2}$  edges, hence all the elements in  $\{a_i\}_{i \in [n-3]}$  have to be distinct, so we can assume that for  $i \in [n-3]$ ,  $a_i = v_i$ .

**Claim.** *If there exists  $i \in [n-3]$  with  $b_i$  (or  $c_i$ ) in  $\{v_1, \dots, v_{n-3}\}$ , then, the co-interval-cover obtained by re-assigning  $b_i$  to a vertex in  $\{v_{n-2}, v_{n-1}, v_n\}$  is a superset of previous one.*

Indeed, if  $b_i = v_j = a_j$  for  $j \in [n-3]$ , then the edges in  $\delta_{a_i, b_i}$  are already in  $\bigcup_{i \in [n-3]} Q_{a_i}$  because  $\delta_{a_i, b_i} = \delta_{a_i, a_j} \subseteq Q_{a_i} \cup Q_{a_j}$ . The same holds if  $c_i = v_j$ .

By the Claim, we can assume that for all  $i \in [n-3]$ ,  $\{b_i, c_i\} \subset \{v_{n-2}, v_{n-1}, v_n\}$ . For  $i, j \in [n-3]$ ,  $i < j$  notice that since  $\{b_i, c_i, b_j, c_j\} \subseteq \{n-2, n-1, n\}$ , either  $b_j \in \{b_i, c_i\}$  or  $c_j \in \{b_i, c_i\}$ . Hence, by Fact 4.23, the intersection between  $\delta_{a_i, b_i} \cup \delta_{a_i, c_i}$  and  $\delta_{a_j, b_j} \cup \delta_{a_j, c_j}$  is not empty. This means that  $E_j$  can add to  $\bigcup_{i \in [j-1]} E_i$  at most  $|E_j| - (j-1)$  new edges. Hence,

$$\left| \bigcup_{i \in [n-3]} E_i \right| \leq (n-3) \frac{(n+2)(n-1)}{2} - \sum_{j=2}^{n-3} (j-1) < |E(L(K_n))|.$$

*Case 2: all edge sets, except one, are of type (a).*

For all  $i \in [n-4]$ ,  $E_i \supset Q_{a_i} \cup \delta_{a_i, b_i} \cup \delta_{a_i, c_i}$  for distinct  $a_i, b_i, c_i \in V(K_n)$ , and  $E_{n-3} \supset \delta_{a_{n-3}, b_{n-3}} \cup \delta_{a_{n-3}, c_{n-3}}$  for distinct  $a_{n-3}, b_{n-3}, c_{n-3} \in V(K_n)$ . We reach a contradiction by showing that for any assignment of  $\{(a_i, b_i, c_i)\}_{i \in [n-3]}$  the set  $\bigcup_{i \in [j-1]} E_i$  does not have enough edges to cover  $E(L(K_n))$ . This is the case when the number of edges that appear at least twice is strictly larger than  $n-6$ .

As before, we can assume the vertices in  $\{a_i\}_{i \in [n-4]}$  are all distinct and  $\{b_i, c_i\} \subset V(K_n) \setminus \{a_i\}_{i \in [n-4]}$ . Moreover,  $a_{n-3}, b_{n-3}, c_{n-3}$  have to be distinct from the previous  $a_i$  because otherwise there exists  $i$  such that  $|E_i \cap E_{n-3}| \geq |Q_{a_i} \cap (\delta_{a_{n-3}, b_{n-3}} \cup \delta_{a_{n-3}, c_{n-3}})| \geq n-2$  and there are too many edges that appear at least twice. We can assume  $a_i = v_i$  for all  $i \in [n-3]$ , and  $(b_{n-3}, c_{n-3}) = (v_{n-2}, v_{n-1})$ . Further, observe that if  $v_n$  is distinct from all  $b_i$  and  $c_i$  ( $i \in [n-4]$ ), then the edges in  $Q_{v_n}$  are not covered so, we can assume  $b_1 = v_n$ .

Now, for all  $2 \leq i \leq n-4$ ,  $b_i \in \{v_{n-3}, v_{n-2}, v_{n-1}, v_n\}$ , so by Fact 4.23,  $\delta_{a_i, b_i}$  intersects  $\delta_{a_1, v_n} \cup \delta_{a_{n-3}, v_{n-2}} \cup \delta_{a_{n-3}, v_{n-1}}$ . The same holds for  $\delta_{a_i, c_i}$ . This means that  $E_j$  can add to  $E_1 \cup E_{n-3}$  at most  $|E_j| - 2$  new edges. Hence,

$$\left| \bigcup_{i \in [n-3]} E_i \right| \leq (n-4) \frac{(n+2)(n-1)}{2} + 5(n-2) - \sum_{j=2}^{n-4} 2 < |E(L(K_n))|.$$

□

There are two natural problems to consider after Theorem 4.21. First, since we study only the complement of the line graph of a complete graph, one could wonder what happens

for general graphs. We analyze the boxicity of  $\overline{L(G)}$  for a graph  $G$  in [15]. Second, since  $\overline{L(K_n)} = K(n, 2)$  one could consider, more generally, the Kneser graph  $K(n, k)$  for  $k \geq 2$ . We proved the following bounds in our work with Lyuben Lichev [14].

**Theorem 4.26.** (Caoduro and Lichev, 2021) *Fix two positive integers  $k, n$  with  $n \geq 2k + 1$ . The boxicity of the Kneser graph  $K(n, k)$  is at most  $n - 2$ . Moreover, if  $n \geq 2k^3 - 2k^2 + 1$ , then  $\text{box}(K(k, n)) \geq n - \frac{13k^2 - 11k + 16}{2}$ .*

The upper bound of  $n - 2$  is tight for  $k = 2$  (Theorem 4.21), but the upper and lower bounds are far apart for larger values of  $k$ . Even for  $k = 3$ , it is unclear which value to conjecture for  $\text{box}(K(n, 3))$ . We believe that a generalization of Lemma 4.20 could be a helpful tool to deal with this problem.



# Conclusion

This thesis studied the relationship between the hitting and packing numbers and the chromatic and clique numbers. Along the way, we presented several binding functions. For axis-parallel segments, we found the asymptotically optimal one, showing that Wegner's conjecture trivially holds and is asymptotically tight for this particular class of rectangles (Theorem 2.4). For other classes, such as cross-free axis-parallel rectangles and axis-parallel rectangles with an aspect ratio bounded by  $\rho$ , we improved on the best-known bound. In the first case, we reduced the constant in the linear bound from 12 to 8 (Theorem 0.10), while in the second case, we improved the dependency on  $\rho$  from linear to logarithmic (Theorem 1.27). Also, we took a further step in understanding the combinatorial properties of (not necessarily axis-parallel) squares by offering linear bounds, with relatively small constants, on  $\tau$  and  $\chi$  in terms of  $\nu$  and  $\omega$  (Theorems 3.2 and 3.4, respectively).

Boxicity is another topic we explored in this manuscript. In an attempt to find tight examples or counterexamples to the stated conjectures, we tried to represent several popular graphs as rectangle graphs. These candidates turned out not to be rectangle graphs. Moreover, while studying the Petersen graph (that is,  $\overline{L(K_5)}$ ), we could determine the boxicity of the superclass of the complement of line graphs of  $K_n$  for  $n \geq 3$ , proving a conjecture we previously proposed in [14].

Numerous problems and questions have been asked and collected in this manuscript. We present here our favorite ones.

First, we select three special cases of Wegner's conjecture.

**Question 1:** *Wegner's conjecture for  $\nu = 4$ .*

Is there a family of axis-parallel rectangles with  $\nu = 4$  and  $\tau = 8$ , refuting Wegner's conjecture in its exact form?

**Question 2:** *Wegner's conjecture for triangle-free families of rectangles.*

Does Wegner's conjecture hold for every triangle-free family of axis-parallel rectangles  $\mathcal{R}$ ? Or equivalently, is  $\nu(\mathcal{R}) \geq \frac{n+2}{4}$ ?

**Question 3:** *Wegner's conjecture for squares.*

Does Wegner's conjecture hold for axis-parallel squares? Moreover, does  $\chi \leq 2\omega - 1$  hold for any family of axis-parallel squares?

Second, by studying squares in the plane, many open questions emerged. We select what seems to be the most surprising to remain open.

**Question 4:** *Hitting pairwise intersecting squares.*

What is the minimum number of points needed to hit every family of pairwise (not necessarily axis-parallel) squares in the plane? Can the lower bound of 4 be increased? And, is the minimum for the special case of unit squares 3 or 4?

Having reached the last paragraph of this manuscript, it is time to give our opinion on Wegner's conjecture. After three years of work on this problem, it seems likely that a linear bound of the hitting number in terms of the packing number is achievable (this is also known as the Gyárfás-Lehel's conjecture [49, Problem 4.3]). On the other hand, the constant of 2 proposed in Wegner's conjecture may be too optimistic and reflect only the lack of tools. Recently, many examples appeared showing the tightness of Wegner's conjecture in various special cases (e.g. Theorem 1.23 [28], and [20, Theorem 4]). Also, at the end of Section 2.2 we noted that the multiplicative constant of Wegner's conjecture is tight in the highly constrained case of triangle-free axis-parallel unit segments. This makes us believe that there is still much work to be done on lower bounds and that a counterexample of Wegner's conjecture may appear on a less restricted case by exploiting the thickness of rectangles and the possibility of having large cliques.

# Bibliography

- [1] P. K. Agarwal, M. van Kreveld, and S. Suri. “Label placement by maximum independent set in rectangles”. In: *Computational Geometry* 11 (1998), pp. 209–218.
- [2] R. Ahlswede and I. Karapetyan. “Intersecting graphs of rectangles and segments”. In: *LNCS* 4123 (2006), pp. 1064–1065.
- [3] A. Akopyan. “Intersection of Parallelepipeds in  $\mathbb{R}^d$ ”. In: 83 (2008), pp. 153–156.
- [4] K. Appel and W. Haken. “Every planar map is four colorable. Part I: Discharging”. In: *Illinois Journal of Mathematics* 21.3 (1977), pp. 429–490.
- [5] K. Appel, W. Haken, and J. Koch. “Every planar map is four colorable. Part II: Reducibility”. In: *Illinois Journal of Mathematics* 21.3 (1977), pp. 491–567.
- [6] B. Aronov, E. Ezraand, and M. Shair. “Small-Size  $\epsilon$ -Nets for Axis-Parallel Rectangles and Boxes”. In: *Proceedings of the Forty-First Annual ACM Symposium on Theory of Computing*. STOC ’09. Bethesda, MD, USA: Association for Computing Machinery, 2009, pp. 639–648. ISBN: 9781605585062.
- [7] E. Asplund and B. Grünbaum. “On a coloring problem”. In: *Math. Scand.* 8 (1960), pp. 181–188.
- [8] S. Bellantoni, I. Ben-Arroyo Hartman, T. Przytycka, and S. Whitesides. “Grid intersection graphs and boxicity”. In: *Discrete Mathematics* 114.1 (1993), pp. 41–49. ISSN: 0012-365X.
- [9] D. Bhowmick and L. Chandran. “Boxicity of Circular Arc Graphs”. In: *Graphs and Combinatorics* 27 (Nov. 2011), pp. 769–783.
- [10] A. Bielecki. “Problem 56”. In: *Colloq. Math* 1 (1948), p. 333.
- [11] A. Biniáz, P. Bose, and Y. Wang. “Simple Linear Time Algorithms For Piercing Pairwise Intersecting Disks”. In: *Proceedings of the 33rd Canadian Conference on Computational Geometry*. CCCG 2021. Dalhousie University Halifax, Nova Scotia Canada, 2021, pp. 228–236.
- [12] H. Bruhn. *Boxicity (Meeting in honor of András Sebő)*. URL: [https://pagesperso.g-scop.grenoble-inp.fr/~szigetiz/SA60/talkspdf/13\\_enning.pdf](https://pagesperso.g-scop.grenoble-inp.fr/~szigetiz/SA60/talkspdf/13_enning.pdf). Mar. 2014.
- [13] M. Caoduro, J. Cslovjecsek, M. Pilipczuk, and K. Węgrzycki. *Independence number of intersection graphs of axis-parallel segments*. 2022. arXiv: [2205.15189](https://arxiv.org/abs/2205.15189).
- [14] M. Caoduro and L. Lichev. *On the Boxicity of Kneser Graphs and Complements of Line Graphs*. 2021. arXiv: [2105.02516](https://arxiv.org/abs/2105.02516).
- [15] M. Caoduro and A. Sebő. *Boxicity: Simple proofs for Popular graphs and Polynomial Algorithms for Superclasses*. In preparation. Aug. 2022.

- [16] M. Caoduro and A. Sebő. *Packing, Hitting and Coloring Squares*. 2022. arXiv: [2206.02185](https://arxiv.org/abs/2206.02185).
- [17] P. Chalermsook and J. Chuzhoy. “Maximum Independent Set of Rectangles”. In: *Proceedings of the 2009 Annual ACM-SIAM Symposium on Discrete Algorithms (SODA)*. 2009, pp. 892–901.
- [18] P. Chalermsook and B. Walczak. “Coloring and maximum weight independent set of rectangles”. In: *Proceedings of the Thirty-Second Annual ACM-SIAM Symposium on Discrete Algorithms*. Society for Industrial and Applied Mathematics, 2021, pp. 860–868.
- [19] T. M. Chan. “Polynomial-time approximation schemes for packing and piercing fat objects”. In: *Journal of Algorithms* 46.2 (2003), pp. 178–189. ISSN: 0196-6774.
- [20] K. Chen and A. Dumitrescu. “On Wegner’s inequality for axis-parallel rectangles”. In: *Discrete Mathematics* 343.12 (2020), p. 112091.
- [21] Y. Chen. “Kneser Graphs Are Hamiltonian For  $n \geq 3k$ ”. In: *Journal of Combinatorial Theory, Series B* 80 (1) (2000), pp. 69–79.
- [22] M. Chudnovsky, N. Robertson, P. Seymour, and R. Thomas. “The strong perfect graph theorem”. In: *Annals of Mathematics. Second Series* 164.1 (2006), pp. 51–229. ISSN: 0003-486X.
- [23] M. Chudnovsky, S. Spirkl, and S. Zerbib. “Piercing axis-parallel boxes”. In: *The Electronic Journal of Combinatorics* 25(1) (2018), P1.70.
- [24] V. Chvátal. “The minimality of the mycielski graph”. In: *Graphs and Combinatorics*. Ed. by Ruth A. Bari and Frank Harary. Berlin, Heidelberg: Springer Berlin Heidelberg, 1974, pp. 243–246. ISBN: 978-3-540-37809-9.
- [25] V. Chvátal. “The smallest triangle-free 4-chromatic 4-regular graph”. In: *Journal of Combinatorial Theory* 9.1 (1970), pp. 93–94. ISSN: 0021-9800.
- [26] S. A. Cook. “The Complexity of Theorem-Proving Procedures”. In: *Proceedings of the Third Annual ACM Symposium on Theory of Computing*. STOC ’71. Shaker Heights, Ohio, USA: Association for Computing Machinery, 1971, pp. 151–158. ISBN: 9781450374644.
- [27] T. H. Cormen, C. E. Leiserson, R. L. Rivest, and C. Stein. *Introduction to Algorithms, Third Edition*. 3rd. The MIT Press, 2009. ISBN: 0262033844.
- [28] J. Correa, L. Feuilloley, P. Pérez-Lantero, and J. A. Soto. “Independent and hitting sets of rectangles intersecting a diagonal line: algorithms and complexity”. In: *Discrete Computational Geometry* 53 (2015), pp. 344–365.
- [29] M. B. Cozzens and F. S. Roberts. “Computing the boxicity of a graph by covering its complement by cointerval graphs”. In: *Discrete Applied Mathematics* 6.3 (1983), pp. 217–228. ISSN: 0166-218X.
- [30] R. Diestel. *Graph Theory (Graduate Texts in Mathematics)*. Springer, 2005. ISBN: 3540261826.
- [31] R. P. Dilworth. “A Decomposition Theorem for Partially Ordered Sets”. In: *Annals of Mathematics* 51.1 (1950), pp. 161–166. ISSN: 0003486X.
- [32] A. Dumitrescu and M. Jiang. “Coloring translates and homothets of a convex body”. In: *Contributions to Algebra and Geometry* 53 (2012), pp. 365–377.

- [33] A. Dumitrescu and M. Jiang. “Piercing translates and homothets of a convex body”. In: *Algorithmica* 61 (2011), pp. 94–115.
- [34] P. Erdős and G. Szekeres. “A combinatorial problem in geometry”. In: *Compositio mathematica* 2 (1935), pp. 463–470.
- [35] L. Esperet and G. Joret. “Boxicity of Graphs on Surfaces”. In: *Graphs and Combinatorics* 29 (2013), pp. 417–427.
- [36] S. P. Fekete, K. Huang, J. S. B. Mitchell, O. Parekh, and C. A. Phillips. “Geometric Hitting Set for Segments of Few Orientations”. In: *Sanità L., Skutella M. (eds) Approximation and Online Algorithms. WAOA 2015*. Springer, Cham, 2015, pp. 145–157.
- [37] P. C. Fishburn. “Intransitive indifference with unequal indifference intervals”. In: *Journal of Mathematical Psychology* 7.1 (1970), pp. 144–149. ISSN: 0022-2496.
- [38] D. G. Fon Der Flaass and A. V. Kostochka. “Covering boxes by points”. In: *Discrete Mathematics* 120 (1993), pp. 269–275.
- [39] P. Frankl and Z. Füredi. “Extremal problems concerning Kneser Graphs”. In: *Journal of Combinatorial Theory, Series B* 40 (1986), pp. 270–284.
- [40] T. Gallai. “Neuer Beweis eines Tutte’schen Satzes”. In: *Magyar Tud. Akad. Mat. Kutató Int. Közl.* 8 (1963), pp. 135–139.
- [41] W. Gálvez, A. Khan, M. Mari, T. Mömke, M. R. Pittu, and A. Wiese. “A  $(2 + \varepsilon)$ -Approximation Algorithm for Maximum Independent Set of Rectangles”. In: *CoRR* abs/2106.00623 (2021).
- [42] W. Gálvez, A. Khan, M. Mari, T. Mömke, M. R. Pittu, and A. Wiese. “A 3-Approximation Algorithm for Maximum Independent Set of Rectangles”. In: *Proceedings of the 2022 ACM-SIAM Symposium on Discrete Algorithms, SODA 2022*. SIAM, 2022, pp. 894–905.
- [43] M. R. Garey and D. S. Johnson. *Computers and Intractability: A Guide to the Theory of NP-Completeness (Series of Books in the Mathematical Sciences)*. First Edition. W. H. Freeman, 1979. ISBN: 0716710455.
- [44] M. C. Golumbic. “Chapter 8 - Interval graphs”. In: *Algorithmic Graph Theory and Perfect Graphs*. Ed. by M. C. Golumbic. Vol. 57. Annals of Discrete Mathematics. Elsevier, 2004, pp. 171–202.
- [45] H. Grötzsch. “Zur Theorie der diskreten Gebilde, VII: Ein Dreifarbensatz für dreikreisfreie Netze auf der Kugel”. In: *Math.-Nat. Reihe* 8 (1959), pp. 109–120.
- [46] B. Grünbaum. “On intersections of similar sets”. In: *Portugaliae mathematica* 18.3 (1959), pp. 155–164.
- [47] U. I. Gupta, D. T. Lee, and Joseph Y.-T. Leung. “Efficient algorithms for interval graphs and circular-arc graphs”. In: *Networks* 12 (1982), pp. 459–467.
- [48] A. Gyárfás. *Combinatorics of Intervals. unpublished*, 2003.
- [49] A. Gyárfás and J. Lehel. “Covering and coloring problems for relatives of intervals”. In: *Discrete Mathematics* 55 (1985), pp. 161–166.
- [50] A. Gyárfás, A. Sebő, and N. Trotignon. “The chromatic gap and its extremes”. In: *Journal of Combinatorial Theory, Series B* 102.5 (2012), pp. 1155–1178. ISSN: 0095-8956.



- [51] H. Hadwiger and H. Debrunner. “Ausgewahlte Einzelprobleme der kombinatorischen Geometrie in der Ebene”. In: *Enseignement Math* 2 (1955), pp. 56–89.
- [52] W.K. Hale. “Frequency assignment: Theory and applications”. In: *Proceedings of the IEEE* 68.12 (1980), pp. 1497–1514.
- [53] I. Ben-Arroyo Hartman, I. Newman, and R. Ziv. “On grid intersection graphs”. In: *Discrete Mathematics* 87.1 (1991), pp. 41–52. ISSN: 0012-365X.
- [54] D. J. Harvey and D. R. Wood. “Treewidth of the Kneser Graph and the Erdős-Ko-Rado Theorem”. In: *The Electronic Journal of Combinatorics* 21(1) (2014).
- [55] A. Kamibepu. “Bounds for the boxicity of Mycielski graphs”. In: *Contributions to Discrete Mathematics* 13 (Jan. 2018), pp. 63–78.
- [56] Gy. Károlyi. “On point covers of parallel rectangles”. In: *Periodica Math. Hung.* 23 (1991), pp. 105–107.
- [57] A. B. Kempe. “I. A memoir on the theory of mathematical form”. In: *Philosophical Transactions of the Royal Society of London* 177 (1886), pp. 1–70.
- [58] S. Khanna, S. Muthukrishnan, and M. Paterson. “On Approximating Rectangle Tiling and Packing”. In: *Proceedings of the Ninth Annual ACM-SIAM Symposium on Discrete Algorithms*. SODA 98. San Francisco, California, USA, 1998, pp. 384–393. ISBN: 0898714109.
- [59] S. J. Kim, A. Kostochka, and K. Nakprasit. “On the chromatic number of intersection graphs of convex sets in the plane”. In: *The Electronic Journal of Combinatorics* 11 (2004).
- [60] S. J. Kim, K. Nakprasit, M. J. Pelsmayer, and J. Skokan. “Transversal numbers of translates of a convex body”. In: *Discrete Mathematics* 306.18 (2006), pp. 2166–2173.
- [61] M. Kneser. “Aufgabe 360”. In: *Jahresbericht der Deutschen Mathematiker-Vereinigung* 2 27 (1956).
- [62] A. Kostochka. “Coloring intersection graphs of geometric figures with a given clique number”. In: *Towards a Theory of Geometric Graphs*. Vol. 342. 2004, pp. 127–138. ISBN: 9780821834848.
- [63] A.V. Kostochka and I.G. Perepelitsa. “Colouring triangle-free intersection graphs of boxes on the plane”. In: *Discrete Mathematics* 220.1 (2000), pp. 243–249. ISSN: 0012-365X.
- [64] J. Kratochvíl and J. Matoušek. “Intersection Graphs of Segments”. In: *Journal of Combinatorial Theory, Series B* 62 (1994), pp. 289–315.
- [65] J. Kratochvíl and J. Nešetřil. *INDEPENDENT SET and CLIQUE problems intersection-defined classes of graphs*. 1990.
- [66] T. Krawczyk and B. Walczak. “On-line approach to Off-Line coloring problems on graphs with geometric representations”. In: *Combinatorica* 37.6 (2016), pp. 1139–1179.
- [67] C. Lekkerkerker and J. Boland. “Representation of a finite graph by a set of intervals on the real line”. In: *Fundamenta Mathematicae* 51.1 (1962), pp. 45–64.

- [68] L. Lewin-Eytan, J.S. Naor, and A. Orda. “Routing and Admission Control in Networks with Advance Reservations”. In: *Approximation Algorithms for Combinatorial Optimization*. Ed. by Klaus Jansen, Stefano Leonardi, and Vijay Vazirani. Berlin, Heidelberg: Springer Berlin Heidelberg, 2002, pp. 215–228. ISBN: 978-3-540-45753-4.
- [69] L. Lovász. “Kneser’s conjecture, chromatic number, and homotopy”. In: *Journal of Combinatorial Theory, Series A* 25 (1978), pp. 319–324.
- [70] T. A. McKee and E. R. Scheinerman. “On the chordality of a graph”. In: *Journal of Graph Theory* 17.2 (1993), pp. 221–232.
- [71] L. Mirsky. “A Dual of Dilworth’s Decomposition Theorem”. In: *The American Mathematical Monthly* 78.8 (1971), pp. 876–877.
- [72] J. Mycielski. “Sur le coloriage des graphs”. In: *Colloquium Mathematicae* 3.2 (1955), pp. 161–162.
- [73] J. Nešetřil. “A Combinatorial Classic — Sparse Graphs with High Chromatic Number”. In: *Erdős Centennial*. Ed. by László Lovász, Imre Z. Ruzsa, and Vera T. Sós. Berlin, Heidelberg: Springer Berlin Heidelberg, 2013, pp. 383–407.
- [74] K.J. Nurmela and P.R.J. Östergård. *Covering a Square with up to 30 Equal Circles*. WorkingPaper HUT-TCS-A62. Helsinki University of Technology, 2000, p. 14.
- [75] S. Olariu. “An optimal greedy heuristic to color interval graphs”. In: *Information Processing Letters* 37.1 (1991), pp. 21–25. ISSN: 0020-0190.
- [76] J. Pach. “Decomposition of multiple packing and covering”. In: *2. Kolloquium über Diskrete Geometrie* (1980), pp. 169–178.
- [77] J. Pach and J. Törócsik. “Some geometric applications of Dilworth’s theorem”. In: *Discrete & Computational Geometry* 12.1 (1994), pp. 1–7.
- [78] A. Pawlik, J. Kozik, T. Krawczyk, M. Lasoń, P. Micek, W. T. Trotter, and B. Walczak. “Triangle-Free Geometric Intersection Graphs with Large Chromatic Number”. In: *Discrete & Computational Geometry* 50.3 (2013), pp. 714–726.
- [79] I.G. Perepelitsa. “Bounds on the chromatic number of intersection graphs of sets in the plane”. In: *Discrete Mathematics* 262 (2003), pp. 221–227.
- [80] J. Petersen. “Sur le théorème de Tait”. In: *L’Intermédiaire des Mathématiciens* 5 (1898), pp. 225–227.
- [81] S. P. Radziszowski. “Small Ramsey Numbers”. In: *Electronic Journal of Combinatorics* 1000 (2011).
- [82] F.S. Roberts. “On the boxicity and cubicity of a graph”. In: *W.T. Tutte (Ed.), Recent Progress in Combinatorics*. New York: W.T. Tutte (Ed.), Academic Press, 1969, pp. 301–310.
- [83] E. R. Scheinerman. “Intersection Classes and Multiple Intersection Parameters of Graphs”. PhD thesis. Princeton University, 1984.
- [84] A. Schrijver. *Combinatorial Optimization. Polyhedra and Efficiency*. Publisher Springer Berlin, Heidelberg, 2003. ISBN: 978-3-540-44389-6.
- [85] M. Stehlík. “Minimal Connected  $\tau$ -Critical Hypergraphs”. In: *Graphs and Combinatorics* 22 (2006), pp. 421–426.

- [86] R. Steinberg and C.A. Tovey. "Planar Ramsey Numbers". In: *Journal of Combinatorial Theory, Series B* 59.2 (1993), pp. 288–296. ISSN: 0095-8956.
- [87] C. Thomassen. "Interval representations of planar graphs". In: *Journal of Combinatorial Theory, Series B* 40.1 (1986), pp. 9–20. ISSN: 0095-8956.
- [88] C. Toregas, R. Swain, C. ReVelle, and L. Bergman. "The Location of Emergency Service Facilities". In: *Operations Research* 19.6 (1971), pp. 1363–1373.
- [89] W. T. Trotter. "A Characterization of Robert's Inequality for Boxicity". In: *Discrete Math.* 28.3 (1979), pp. 303–313. ISSN: 0012-365X.
- [90] G. Wegner. "Über eine kombinatorisch-geometrische Frage von Hadwiger und Debrunner". In: *Israel J. Math* 3 (1965), pp. 187–198.