



HAL
open science

Cooperative Communications in Ad Hoc Networks

Wasimon Panichpattanakul

► **To cite this version:**

Wasimon Panichpattanakul. Cooperative Communications in Ad Hoc Networks. Networking and Internet Architecture [cs.NI]. Institut National Polytechnique de Toulouse - INPT, 2010. English. NNT : 2010INPT0092 . tel-04275803

HAL Id: tel-04275803

<https://theses.hal.science/tel-04275803>

Submitted on 8 Nov 2023

HAL is a multi-disciplinary open access archive for the deposit and dissemination of scientific research documents, whether they are published or not. The documents may come from teaching and research institutions in France or abroad, or from public or private research centers.

L'archive ouverte pluridisciplinaire **HAL**, est destinée au dépôt et à la diffusion de documents scientifiques de niveau recherche, publiés ou non, émanant des établissements d'enseignement et de recherche français ou étrangers, des laboratoires publics ou privés.



Université
de Toulouse

THÈSE

En vue de l'obtention du
DOCTORAT DE L'UNIVERSITÉ DE TOULOUSE

Délivré par :
Institut National Polytechnique de Toulouse (INP Toulouse)

Discipline ou spécialité :
Réseaux, Télécommunications, Système et Architecture

Présentée et soutenue par :
Wasimon PANICHPATTANAKUL

le : vendredi 5 novembre 2010

Titre :
Cooperative Communications in Ad Hoc Networks

JURY

M. Khaldoun AL AGHA, Prof., Université PARIS 11, Rapporteur/Président
Mme Caroline BES, Ingénieur Dr. CNES, Membre
Dr. Benoît ESCRIG, MCF Dr. INPT/ENSEEIH, Membre
Mme Béatrice PAILLASSA, Prof. INPT/ENSEEIH, Membre
M. Daniel ROVIRAS, Prof. CNAM, Membre

Ecole doctorale :
Mathématiques Informatique Télécommunications (MITT)

Unité de recherche :
UMR 5505 - IRIT

Directeur(s) de Thèse :
Mme Béatrice PAILLASSA
M. Daniel ROVIRAS

Rapporteurs :
M. Khaldoun AL AGHA
M. Kosai RAOOF

Cooperative Communications in Ad Hoc Networks

Wasimon PANICHPATTANAKUL

This thesis is supervised by

Prof. Béatrice PAILLASSA – Thesis director

Prof. Daniel ROVIRAS – Thesis co-director

Dr. Benoît ESCRIG – Thesis advisor

A ma mère
Je te suis reconnaissant de t'être si bien occupé de moi.
Tu m'as toujours soutenu et fais part de ta fierté à mon encontre.
Maman, je suis si fier de toi.
Je t'aime.

Acknowledgements

Vivre et étudier à l'étranger seul est l'une des expériences les plus intéressantes de ma vie. J'ai apprécié chaque moment de ma vie d'étude à Toulouse malgré l'éloignement loin de mon pays d'origine la Thaïlande parce que j'y ai rencontré de nombreuses personnes sympathiques. Et aujourd'hui, je peux dire que le jour de ma soutenance de thèse fut un jour très heureux. Je voudrais exprimer ma reconnaissance à toutes ces personnes sans lesquelles je n'aurais sans doute pas réussi.

Tout d'abord, je voudrais exprimer mes sincères remerciements à mon directeur de thèse, le professeur Béatrice PAILLASSA, pour ses conseils, ses encouragements, et sa relation au travail. Tout cela m'a été utile sous tous aspects, que ce soit pour mes études ou pour ma vie. Je remercie également mon codirecteur de thèse (professeur Daniel ROVIRAS) ainsi que mon co-encadrant (Dr. Benoît ESCRIG) pour leur bonté et leurs conseils.

Mes très vifs remerciements s'adressent aux membres du jury de thèse qui ont accepté de juger ce travail. Je suis profondément reconnaissant à mes deux rapporteurs, Monsieur Khaldoun AL AGHA et Monsieur Kosai RAOOF, d'avoir accepté de lire et d'évaluer ma thèse. Je tiens également à remercier Madame Caroline BES qui m'a fait l'honneur de participer au jury.

Merci au personnel du laboratoire, de l'INPT et de l'UPS pour les aides permanentes reçues. Je remercie en particulier Sylvie EICHEN et Sylvie ARMENGUAD qui ont été disponibles à chaque fois que j'ai eu besoin d'aide.

Je remercie également l'ensemble des enseignants et doctorants qui m'ont offert un excellent cadre de travail ont rendu mon séjour extrêmement agréable. Merci à Michel DAYDE, André-Luc BEYLOT, Emmanuel CHAPUT, Jérôme ERMONT, Julien FASSON, Sakuna CHAREONPANYASAK, Cholatip YAWUT, Rahim KACIMI, Alexandra NICULAE, Amadou Baba BAGAYOKO, et Warodom WERAPUN.

Je voudrais adresser aussi un grand merci à tous mes amis français et thaïlandais. Merci à Emeline, J.M., Manu, Christelle, Florent, Mélanie, Silvia, Valérie, Christophe, P'Pierre, P'Por, P'Ning, Chapumt, P'Tom+, P'Ae+, P'Keng', P'A, P'Nop, P'Chin, P'Ae, Vee, N'Tan, N'Eak, N'Boy, N'View, N'Meaw, N'Sing, N'Prea, N'Kla, N'Vee, N'Chol, et tous ceux que je n'ai pas mentionné ici.

Que mon université d'origine, Prince of Songkla University, et le gouvernement français soient également remerciés pour leur aide.

Enfin et surtout, je voudrais exprimer ma sincère gratitude à mes parents et à ma sœur pour leur soutien sans faille. Ce grand succès n'aurait pu avoir lieu sans eux. Leur amour et encouragement sont les facteurs les plus importants de cet accomplissement.

Acknowledgement	I
Indexes	III
Figure Indexes	VII
Table indexes	XI
Introduction	1
1 Wireless Communications	7
1.1 Diversity	9
1.1.1 Time diversity	9
1.1.2 Frequency diversity	10
1.1.3 Spatial diversity	10
1.2 Multiple-Input Multiple-Output (MIMO)	11
1.2.1 Properties of MIMO transmissions	11
1.2.2 Limitations of MIMO transmission	13
1.3 Cooperative communications	13
1.3.1 Properties of Cooperative Communications	15
1.3.2 Limitations of Cooperative Communications	16
1.4 Conclusion	17
2 Cooperative Transmissions at the Physical Layer	19
2.1 Forwarding schemes	21
2.2 Cooperative transmission modes	25
2.1.1 Fixed relaying	26
2.1.2 Adaptive relaying.....	26
2.3 Cooperative Scenarios	27
2.4 Channel access	28
2.4.1 Multiplexing	28
2.4.2 Channel access at the MAC layer	29
2.4.3 Resource optimization, the coding issue	29
2.5 System parameters	32
2.5.1 Relay locations	32
2.5.2 Number of relay terminals	32
2.5.3 Channel availability	33
2.6 Conclusion	34

3	Cooperative Setup Analysis	35
3.1	Cooperative setup in the MAC layer	39
3.1.1	IEEE 802.11 MAC standard	39
3.1.2	Distributed relay selections	42
3.1.3	Centralized relay selections	45
3.1.4	Conclusion of cooperative setup in the MAC layer	48
3.2	Cooperative setup in the Network layer	49
3.2.1	Cooperative setup in the network layer mainly concerns with relay selections	49
3.2.2	Cooperative setup in the network layer with all details of cooperative setup	51
3.2.3	Conclusion of cooperative setup in the network layer	53
3.3	Comparisons of cooperative setup in the MAC layer and the network layer	54
3.4	Conclusion	56
4	Cooperative Network Model	57
4.1	Proposed Model (Cooperative Network Model)	59
4.2	Data plane	60
4.3	Control plane	63
4.3.1	CF1: Cooperative mode activations	63
4.3.2	CF2: Cooperative information acquisitions	65
4.3.3	CF3: Relay selection algorithms	68
4.3.4	CF4: Cooperative mode notifications	68
4.4	Applying the proposed cooperative network model to existing protocols	71
4.4.1	Modelling the ACR protocol: Cooperative setup in the network layer	72
4.4.2	Modelling the DCM protocol: Distributed cooperative setup in the MAC layer	76
4.4.3	Modelling the CoopMAC protocol: Centralized cooperative setup in the MAC layer	80
4.5	Conclusion	84
5	Proxy Cooperative Transmission	85
5.1	Proxy cooperative (ProxyCoop) transmission background	87
5.2	ProxyCoop transmission	91
5.3	Effects of channel quality to ProxyCoop performance	99
5.3.1	System model	99
5.3.2	Simulation results and analysis	101
5.3.3	Confidence interval	106
5.3.4	Conclusion	106
5.4	Effects of channel quality and channel availability to ProxyCoop performance	107
5.4.1	Interference topology	107
5.4.2	System model	111

5.4.3	Simulation results and analysis	111
5.4.4	Conclusion	120
5.5	Conclusion	122
6	Proxy Cooperative Setup	123
6.1	ProxyCoopSetup Designs	125
6.1.1	Cooperative mode activations	130
6.1.2	CoI acquisitions	131
6.1.3	Relay selection methods	139
6.1.4	Cooperative mode notifications	140
6.2	ProxyCoopSetup Performance	146
6.2.1	System model and simulation parameters	146
6.2.2	Simulation results and analysis	147
6.3	Proxy cooperative communications in IEEE 502.11s WLAN mesh networks	152
6.4	Conclusion	154
	Conclusion	155
	Acronyms	157
	Bibliographies	161

Figure Indexes

1	Thesis organization	4
1.1.1.	A repetition technique	9
1.1.2.1	Multi carrier communications	10
1.1.3.1	SIMO transmissions	11
1.2.1.1	Binary error probability P_b curve	12
1.3.1	An example of cooperative scenario	14
1.3.2	An example of cooperative scenario in multi-hop networks	14
1.3.1.1	BER of cooperative and non-cooperative communications in Rayleigh fading channels	15
2.1.1	Forwarding schemes (a) Amplify-and-Forward (AF) scheme and (b) Decode-and-Forward (DF) scheme	22
2.1.2	The performance of the AF transmission scheme	24
2.1.3	The performance of the DF transmission scheme	24
2.3.1	An example of the symmetric cooperation in a cellular network	28
2.3.2	An example of the symmetric cooperation in a wireless LAN	28
2.4.1	A simple network coding example	30
2.4.2	(a) Traditional relay cooperative system and (b) Cooperative system with network coding in a cellular network	31
2.4.3	Cooperative system with network coding in an ad-hoc network	31
3.1.1.1	Basic access method of the IEEE 802.11 MAC standard	39
3.1.1.2	Hidden terminal problem	40
3.1.1.3	Optional access method of the IEEE 802.11 MAC standard	40
3.1.1.4	Message flows of cooperative transmission based on IEEE 802.11 MAC standard in (a) basic access method and in (b) optional access method	41
3.1.1.5	An example of hidden terminal problems in cooperative communications	42
3.1.2.1	Frame schedule of the IEEE802.11 DFC-based cooperative MAC	44
3.1.2.2	Hidden terminal problems between PRTs in DCM method	44
3.1.3.1	Message flow in CoopMAC	46
3.1.3.2	The exchange of control packets for CoopMAC	46
3.1.3.3	The exchange of data and ACK packets for CoopMAC	46
3.1.3.4	Hidden terminal problems in CoopMAC method	47
3.2.1.1	An illustrative network with link costs in term of minimum power requirement for data transmissions	50
3.2.2.1	An illustrative network with 6 terminals	51

3.2.2.2	Routing update packet of the terminal 1	52
3.2.2.3	An example of the routing table at terminal 2	52
3.2.2.4	An example of neighbour terminal table at terminal 2	52
3.2.2.5	The resource allocation of ACR	53
4.1.1	Cooperative Network Model	59
4.2.1	A data transmission method in cooperative communications	63
4.3.1.1	Internal cooperative mode activations	64
4.3.1.2	External cooperative mode activations	65
4.3.2.1	Cooperation information signaling among cooperative participating terminals	66
4.3.2.2	Example of Cooperative Information (CoI) signaling	67
4.3.3.1	Relay selections	68
4.3.4.1	Cooperative mode notification signaling among cooperative participating terminals	69
4.3.4.2	Example of cooperative mode notification initiated by the destination terminal D	70
4.3.4.3	Example of cooperative mode notification when the relay terminal R and terminal S are notified	71
4.4.1.1	Data plane and control plane interactions of the ACR protocol at a potential relay terminal R	73
4.4.1.2	Data plane and control plane interactions of the ACR protocol with cooperation bit at a potential relay terminal R	74
4.4.1.3	Data plane and control plane interactions of the ACR protocol with cooperation bit at the source terminal S	74
4.4.1.4	Data plane and control plane interactions of the ACR protocol with cooperation bit at the destination terminal D	75
4.4.1.5	The interaction among cooperative models of all cooperative participating terminals in the ACR protocol	75
4.4.2.1	The interaction among cooperative models of all cooperative participating terminals in the DCM protocol	77
4.4.2.2	Data plane and control plane interactions of the DCM protocol at a PRT R	78
4.4.2.3	Data plane and control plane interactions of the DCM protocol at the source terminal S	79
4.4.2.4	Data plane and control plane interactions of the DCM protocol at the destination terminal D	79
4.4.3.1	The control packet exchanges of CoopMAC based on cooperative network model	81
4.4.3.2	Data plane and control plane interactions of the CoopMAC protocol at the source terminal S	82
4.4.3.3	Data plane and control plane interactions of the CoopMAC protocol at a PRT R	82
4.4.3.4	Data plane and control plane interactions of the CoopMAC protocol at the destination terminal D	83

5.1.1	Direct transmission mode	87
5.1.2	Multi-hop transmission mode	88
5.1.3	An example of multi-hop network	88
5.1.4	Transmission mode transition of non-cooperative transmission	89
5.1.5	Message flows of (a) Non-cooperative transmissions (b) Cooperative transmissions and (c) Non-cooperative transmissions with re-transmission processes	90
5.1.6	Cooperative Network Model	91
5.2.1	Message flows of ProxyCoop	92
5.2.2	Transmission mode transition of ProxyCoop	93
5.2.3	ProxyCoop transmission with basic access method of IEEE 802.11 MAC protocol on the cooperative network model	94
5.2.4	Data transmissions of CoopMAC (a) in the design and (b) in the Implementation.....	96
5.2.5	Basic access method when defer backoff of the relay terminal is set to zero	97
5.2.6	Optional access method when defer backoff of the relay terminal is set to zero	97
5.3.1.1	A 3-terminal network	100
5.3.1.2	Non-cooperative transmission in (a) Direct transmission mode and (b) Multi-hop mode	101
5.3.1.3	ProxyCoop in (a) Direct transmission mode (b) Proxy cooperative transmission mode and (c) Multi-hop mode	101
5.3.2.1	Percentage of data frames sent in multi-hop mode when $P1 = 0.1$	102
5.3.2.2	Percentage of data frames sent in multi-hop mode when $P1 = 0.2$	102
5.3.2.3	NRDM per second when $P1 = 0.1$	103
5.3.2.4	NRDM per second when $P1 = 0.2$	104
5.3.2.5	PDR when $P1 = 0.1$	105
5.3.2.6	PDR when $P1 = 0.2$	105
5.3.3.1	PDR when $P1=0.2$ with maximum and minimum confidence limits	106
5.4.1.1	Three scenarios of 5-terminal networks	108
5.4.1.2	A scenario of a 9-terminal network	109
5.4.1.3	Data transmissions in the 9-terminal network (a) Non-cooperative transmissions and (b) Proxy cooperative transmissions	109
5.4.1.4	A scenario of a 8-terminal network	110
5.4.1.5	Data transmissions in the 8-terminal network (a) Non-cooperative transmission (b) ProxyCoop Type1 (c) ProxyCoop Type2	110
5.4.3.1	The percentage of data frames sent in multi-hop mode in scenario 1	112
5.4.3.2	PDR of non-cooperative and ProxyCoop transmissions in scenario 1	112
5.4.3.3	The percentage of data frames sent in multi-hop mode in scenario 2	113
5.4.3.4	PDR of non-cooperative and PoxyCoop transmissions in scenario 2	114
5.4.3.5	The percentage of data frames sent in multi-hop mode in scenario 3	115
5.4.3.6	PDR of non-cooperative and ProxyCoop transmissions in scenario 3	115

5.4.3.7	The percentage of data frames sent in multi-hop mode in the 9-terminal network	116
5.4.3.8	PDR of non-cooperative and ProxyCoop transmissions in the 9-terminal network	117
5.4.3.9	The percentage of data frames sent in multi-hop mode in the 8-terminal network	119
5.4.3.10	PDR of non-cooperative and ProxyCoop transmissions in the 8-terminal network	120
6.1.1	RREQ broadcasting	125
6.1.2	RREP process	126
6.1.3	ARP process	127
6.1.4	An example of 5-terminal network	128
6.1.5	ProxyCoopSetup based on AODV routing protocol	129
6.1.1.1	Cooperative mode activation in ProxyCoopSetup	130
6.1.2.1	CoI acquisitions of ProxyCoopSetup at terminal P	131
6.1.2.2	Cooperative mode activations and CoI acquisitions of ProxyCoopSetup at terminal N	133
6.1.2.3	Cooperative mode activations and CoI acquisitions of ProxyCoopSetup at terminal R	132
6.1.2.4	RREQ packet format	133
6.1.2.5	ReREQ packet format	134
6.1.2.6	ReREQ packet spreading	135
6.1.2.7	ReREQ packets in CoI acquisitions	137
6.1.3.1	Data transmissions when relay selection is based on (a) per frame basis and (b) per flow basis	140
6.1.4.1	Cooperative mode notifications of ProxyCoopSetup at terminal N	141
6.1.4.2	Cooperative mode notifications of ProxyCoopSetup at terminal R	142
6.1.4.3	Cooperative mode notifications of ProxyCoopSetup at terminal P	142
6.1.4.4	RREP packet format	143
6.1.4.5	ReREP packet format	144
6.2.1.1	A 3-terminal network	146
6.2.1.2	A 9-terminal network	146
6.2.2.1	The number of route discovery and maintenance (NRDM) per second of the 3-terminal network	148
6.2.2.2	Packet delivery ratio (PDR) of the 3-terminal network	149
6.2.2.3	The number of route discovery and maintenance (NRDM) per second of the 9-terminal network	150
6.2.1.4	Packet delivery ratio (PDR) of the 9-terminal network	151
6.3.1	Network architecture of IEEE 802.11 WLANs	152
6.3.2	Network architecture of IEEE 802.11s WMNs	152
6.3.3	Proxy cooperation (a1) and (a2) in BSS (b) in mesh networks	153

Table Indexes

6.1.2.1	Cooperative table of terminal R after the CoI process	138
6.1.2.2	Cooperative table of terminal N after the CoI process	138
6.1.2.3	Cooperative table of terminal P after the CoI process	138
6.1.4.1	Cooperative table of terminal R after the cooperative mode notification ...	145
6.1.4.1	Cooperative table of terminal N after the cooperative mode notification ...	145
6.1.4.1	Cooperative table of terminal P after the cooperative mode notification ...	145

Motivation

In wireless communications, fading causes errors on data transmissions. Based on IEEE MAC standard [IEEE07], re-transmission processes are required when erroneous data frames are detected. Obviously, re-transmissions increase delay and decrease the packet delivery ratio (PDR) of the network. More precisely, in multi-hop networks, if the re-transmission counter reaches a given threshold, a route recovery process, that generates additional frames, is activated. Since the bandwidth is limited, it can lead to network congestion problems.

In addition, if the route re-discovery process occurs when the direct path from a source terminal S to a destination terminal D is momentarily dropped, the transmission mode can be switched from direct transmission mode to multi-hop transmission mode even if the direct transmission becomes available. Rather than directly transmits a data frame from S to D in one time slot, the multi-hop transmission requires two time slots to respectively send this data frame from S to I and from I to D , where I denotes an intermediate terminal. Therefore, similar to re-transmission processes, multi-hop transmissions can increase delays and decrease PDR of the networks.

Thus, the direct transmission mode must be improved in order to reduce the number of re-transmissions. Multiple-input Multiple-output (MIMO) is an example of transmission techniques that have been proposed to improve transmission performance in wireless communications. MIMO provide the advantages of spatial diversity by generating uncorrelated signal components at a source terminal and/or a destination terminal. However, each antenna in the antenna array must be separated at least $\lambda/2$ in order to provide independent signals, where λ is the wave length of the system and it can be calculated by c/f_c when c is a speed of light (3×10^8 m/s) and f_c is a carrier frequency. Thus, for the commonly used 2.4 GHz frequency band, a space between antennas in the order of 6 cm is required. These requirements make MIMO techniques to be difficult to employ in networks with small wireless terminals such as ad hoc networks and sensor networks. In addition, each terminal in MIMO techniques requires multiple antennas (also called an antenna array) which are costly. Therefore, for these kinds of contexts, cooperative transmissions have been proposed. Cooperative transmissions provide an interesting alternative that can gain benefits of spatial diversity while a single-antenna is required in each terminal. The concept of cooperative transmissions is to exploit the broadcast nature of the wireless medium and to transform single-antenna neighbour terminals, to work as virtual antenna arrays.

Although cooperative transmissions provide benefits of spatial diversity to the networks, they utilize more medium than non-cooperative transmissions since data must be sent at least two times by the source terminal and the relay terminal. However, if the channel quality of a direct path (from a source to a destination terminal) used by non-cooperative transmissions is dropped and re-transmissions are required, cooperative transmissions outperform direct transmissions. Therefore, adaptive cooperative transmissions have been proposed. Rather than remain their transmission mode in cooperative modes all the time, cooperative transmissions should be able to switch their transmission modes between cooperative mode and non-cooperative one.

Previous works on cooperative transmissions have mainly considered the designs of cooperative transmission schemes and how to acquire benefits of spatial diversity based on information theory. Details of relay selections, how cooperative transmissions interact with protocol stack, and resource allocations have not been addressed. These issues have lately been considered in cooperative setup research fields. Thus, cooperative communication designs compose of two major parts; cooperative transmission designs and cooperative setup designs. To fully take advantages of cooperative communications and to implement cooperative communications in real networks, details of cooperative transmission and cooperative setup must be addressed.

Issues in Cooperative Protocols

The first challenge concerns the medium access method in distributed networks. Currently, the most popular Medium Access Control (MAC) protocol is the wifi one; it is conformed to the IEEE 802.11 standard. This protocol can support different transmission rates. The transmission rates are adjusted based on the channel conditions. If the distance between the terminals is important and/or the channel conditions are too bad, the message transmission is done at low rate. Thus, the performance of the whole distributed network (the packet delivery rations, for example) decreases. Moreover, if the channel conditions are really too bad, a network protocol should discover a multi-hop route that will pass through better links. However, multi-hop route may provide less rapid transmission links than the initial route (with the good channel quality). Therefore, the introduction of a relay terminal (or a helper terminal as named by different authors) would lead to high speed cooperative transmission and efficient route. Nevertheless, since a relay terminal and a source terminal have to access to the same medium, some additional exchanges have to be added to the IEEE 802.11 protocol in order to avoid collisions. Various protocols have been proposed in literature. In this content, we will focus on IEEE solutions, which will be presented in chapter 3, since our objective is to propose a MAC solution that is compatible with the IEEE 802.11.

Another challenge is the relay selection issue. Various factors have to be considered such as rate improvement, interference decrease, and fairness in the resource consumption. Obviously, introducing relay terminals provides information transmission improvement; meanwhile, it induces interferences to other terminals in the network. Therefore, the relay

selection must concern the interference that the relay terminal provides to its neighbour terminals. The interference should be minimized. Generally, the authors theoretically analyse the performance of the proposed protocol or simulate them with a simple system with three terminals; therefore, we will also use it in the chapter 5 of this thesis. However, considering the interference aspects, we will extend the analysis to more sophisticated networks. Besides, for the relay selection issue, since the cooperation consumes energy and medium to help the source terminal, power and medium consumptions would be considered in the cooperative process. Thus, in this thesis, we will put forward the evaluation in our work to derive the interesting conditions for cooperation.

Moreover, concerning the interest of cooperative communications in real networks, not only the data transmission level, but also the control level must be addressed. Cooperative transmissions can provide diversity gain in the standpoint of information theory; however, the cooperative protocols require cooperative signaling methods to enable cooperation among terminals. This can decrease the cooperation performance, or even badly impact the system performance in such a way that cooperative communications are worse than non-cooperative communications. Thus, we will propose a method to setup a cooperative communication that aims at reusing some existing protocols and at minimizing the resource consumption in terms of data exchanges.

Contribution

In this thesis, first, we have proposed a “*Cooperative Network Model*” to enable existing cooperative protocol comparisons and facilitate future cooperative protocol designs. The comparisons and designs of cooperative communications are complicated since cooperative communications involve several layers of the Open Systems Interconnection (OSI) model. The cooperative transmissions are done at the physical layer whereas cooperative setup functions; i.e., cooperative mode activations, relay selections, cooperative mode notifications, and resource allocations are implemented at upper layers. To our knowledge, a common framework for cooperative communication comparisons and designs does not exist yet.

Second, we have proposed an adaptive cooperative transmission technique called “*Proxy Cooperative Transmission (ProxyCoop)*”. The proposition is simple but effective. The interoperability issues between terminals with cooperative functionality and legacy terminals have been considered. Based on the IEEE 802.11 medium access control (MAC) protocol, in contrast to other adaptive cooperative transmission methods, ProxyCoop can automatically switch its transmission mode for each data frame between a cooperative mode and a non-cooperative mode based on the absence of acknowledge (ACK) frames. In contrast to other adaptive cooperative transmission techniques, ProxyCoop can compatibly work with the IEEE 802.11 medium access method in both of the basic mode (also called two-hand shaking: Data/ACK) and the optional Request-To-Send/Clear-To-Send (RTS/CTS) mode (also called four-hand shaking: RTS/CTS/Data/ACK) since the RTS/CTS frames are not used or modified in our proposition.

Third, in order to fully take advantages of cooperative transmissions and to implement cooperative transmissions in real networks, a design of cooperative setup based on AODV routing protocol called “*Proxy Cooperative Setup (ProxyCoopSetup)*” is proposed. The proposed cooperative setup responds for cooperative mode activations, relaying data acquisitions, relay selections, and relay notifications. Route Request (RREQ) packets are modified to serve as a control packet for cooperative mode activations and relaying data acquisitions while Route Reply packets are modified to serve as a control packet for cooperative mode notifications.

Thesis organization

This thesis is separated into six chapters as shown in Fig.1. Details of each chapter in brief are as follows;

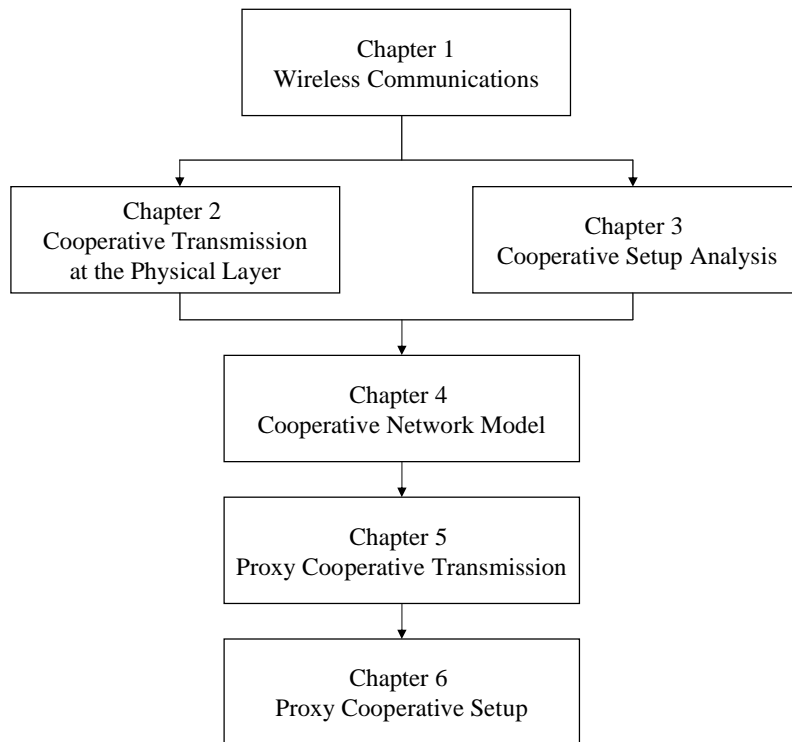

Figure 1: Thesis organization.

Chapter 1: Wireless Communications

An introduction on wireless communications is presented. The objective is to introduce diversity techniques that are used in wireless communications. After a brief review of existing diversity techniques, we focus on spatial diversity techniques and the MIMO transmission schemes. We then introduce an alternative solution to achieve spatial diversity when MIMO techniques are not possible called cooperative communications. Cooperative communications compose of two parts; i.e., cooperative transmission and cooperative setup protocols. These two topics are respectively described in chapter 2 and chapter 3.

Chapter 2: Cooperative Transmission at the Physical Layer

First, forwarding schemes are presented in order to understand how a relay terminal helps a source terminal on data relaying. Then, cooperative transmission modes are presented in order to provide an idea on when the relay terminals have to work on cooperative data relaying. Since the source and relay terminals have to cooperatively transmit data to the destination, channel access methods are described to present how the resource are allocated among cooperative terminals. Finally, the system parameters that influence the cooperative transmission performance are presented.

Chapter 3: Cooperative Setup Analysis

The objective of this chapter is to observe and categorize the literature on *what* and *how* cooperative setup functions have been considered in each cooperative setup protocol. Then, the analyses on the advantages and disadvantages of each type of cooperative setup protocol are presented.

Chapter 4: Cooperative Network Model (A Proposition on a Network Model)

After literature reviews on cooperative transmissions and cooperative setup, we firstly propose a framework for cooperative communications called a “Cooperative Network Model”. Details of our proposition in terms of functional processes and interactions between elements in the model are described. Then, a validation of the proposed framework is given by modeling the existing cooperative setup protocols that have been proposed in the MAC layer and the network layer.

Chapter 5: Proxy Cooperative Transmission (A Proposition on Cooperative Transmission Design)

For our second proposition, we have proposed an adaptive cooperative transmission technique called “ProxyCoop Transmission”. Motivations and details of the proposition are described. Then, the evaluation of ProxyCoop transmission is done by simulations. Finally, simulation result analysis and conclusion are provided.

Chapter 6: Proxy Cooperative Setup (A Proposition on Cooperative Setup Design)

We propose, our third proposition, a cooperative setup protocol called “ProxyCoopSetup”. Firstly, details of ProxyCoopSetup designs are presented. Then, ProxyCoopSetup is implemented in ProxyCoop transmissions in order to study the costs of ProxyCoopSetup

to ProxyCoop transmissions. The evaluation is done by simulations. Then, simulation result analysis and conclusion are provided. Finally, the implementation of the proxy cooperative communication and how it can be integrated on existing networks (WLAN Mesh Networks: WMNs, for example) are presented.

Chapter 1

WIRELESS COMMUNICATIONS

Content

- 1.1. Diversity
 - 1.1.1. Time diversity
 - 1.1.2. Frequency diversity
 - 1.1.3. Spatial diversity
 - 1.2. Multiple-Input Multiple-Output (MIMO)
 - 1.2.1. Properties of MIMO transmissions
 - 1.2.2. Limitations of MIMO transmissions
 - 1.3. Cooperative communications
 - 1.3.1. Properties of Cooperative Communications
 - 1.3.2. Limitations of Cooperative Communications
 - 1.4. Conclusion
-
-

In the past decades, wireless communications have been experiencing exponential growth because they enable multimedia communications between or among people and devices from any location of the service areas. At the same time, wireless devices have been developed to be smaller, cheaper, more convenient, and more powerful in order to run many applications and network services. All of these factors fuel the explosive growth of demand in wireless performance in many aspects such as system capacity and reliability. However, wireless communications suffer from some drawbacks compared to wire-line communications as follows.

Wireless communications are suffering from interference. Interferences come from radio propagation and obstacles objects (multi-path interference), from other users in the system (multi-user interference), and from other systems (inter-system interference). Wireless communication channels are also known to be highly time-varying. These defects limit the performance of wireless systems in terms of reliability, transmission rates, coverage, and energy consumption.

At the physical layer, these issues are addressed by implementing transmission techniques. These transmission techniques are usually described using the common paradigm of **diversity**.

Chapter Organization

This chapter is devoted to the presentation of diversity techniques. After a brief review of existing diversity techniques, we focus on spatial diversity techniques and the MIMO transmission schemes. We then introduce an alternative solution to achieve spatial diversity when implementations of MIMO techniques are difficult, called cooperative communications.

1.1. DIVERSITY

The basic idea of diversity is to transmit and/or to receive uncorrelated signal components. The more the number of uncorrelated components increases, the more the probability that they are all deeply faded decreases. We present the concept of diversity in the three areas: time, frequency, and space.

1.1.1. Time diversity

When studying time diversity in wireless communications, it is useful to consider the time duration over which a wireless channel is considered stationary. This time duration is referred to as the coherence time T_c . A transmission technique is achieving time diversity when it enables the emission and/or reception of signal components separated by time duration of T_c at least. In the following, we present two transmission schemes achieving time diversity.

Repetition scheme

Time diversity can be achieved by repeating the same signal several times as shown in Fig.1.1.1.1. Hence, when the repetition period is greater than the coherence time of the wireless channel, all the replicas are altered by a different wireless channel. So, the probability that one replica can be successfully decoded grows with the number of replicas. The disadvantage of this technique is that it has poor spectral efficiency, the spectral efficiency being the ratio between the transmitted data rate and the frequency band.

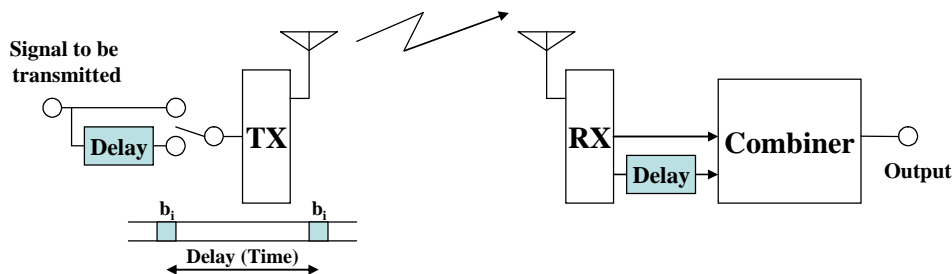

Figure 1.1.1.1: A repetition technique.

Interleaving

An interleaver is used at a source terminal in order to change the symbol ordering. An interleaver is usually built so that two symbols separated by a symbol period at the interleaver input are separated by the coherence time of the wireless channel at the interleaver output. A corresponding de-interleaver is used at a destination terminal in order to restore the original sequence of symbols. So, when error bursts occur in the wireless channel, these bursts are split after the de-interleaver step. Hence, small error sequences are more easily tackled by error correcting decoders. However, the use of interleaving techniques increases the system latency because the system has to wait for an entire interleaved block to be received before the de-interleaving process can be done.

1.1.2. Frequency diversity

When studying frequency diversity in wireless communications, it is useful to consider the bandwidth over which a wireless channel is considered as a constant gain. This frequency band is referred to as the coherence bandwidth B_c . A transmission technique is achieving frequency diversity when it enables the emission and/or reception of signal components separated by a frequency band of B_c at least. In the following, we present two transmission schemes achieving frequency diversity.

Orthogonal frequency-division multiplexing (OFDM): OFDM is a way to achieve frequency diversity. The high data rate stream is divided into several parallel low data rate streams. Each sub-stream is transmitted over a sub-channel, the bandwidth of which is smaller than the coherence bandwidth of the wireless channel. Hence, if the bandwidth of the OFDM system is larger than B_c , the overall data stream is transmitted over sub-channels that are independently attenuated by the wireless channel.

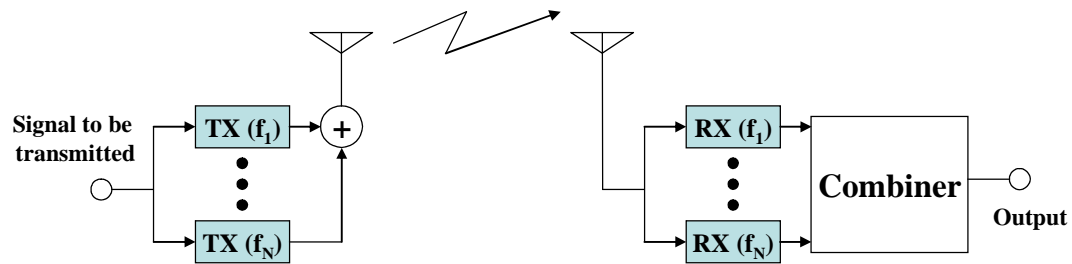

Figure 1.1.2.1: Multi carrier communications.

Frequency hopping (FH): the concept of FH consists in rapidly changing the carrier frequency of the transmitted signal. The switching method among frequency channels is done by a pseudorandom sequence, which is known by both the transmitter and the receiver. Hence, the signal is transmitted over many uncorrelated channels if the total allocated bandwidth is larger than B_c . So when a channel exhibits a deep fade in a given frequency band, the time period over which the signal is transmitted in that particular frequency band is diminished compared to the case of single carrier systems.

1.1.3. Spatial diversity

When studying spatial diversity in wireless communications, it is useful to consider the space separation over which a wireless channel is considered stationary. This space separation is referred to as the coherence distance D_c . A transmission technique is achieving space diversity when it enables the emission and/or reception of signal components separated by a distance of D_c at least. In the following, we present a transmission scheme achieving spatial diversity.

Single Input Multiple Output (SIMO): in a SIMO system, the signal is transmitted by a single antenna terminal and it is received by a terminal with multiple antennas. As long as the several antennas of the receiver are spaced by a distance larger than D_c , the fading experienced by received signals can be considered as being uncorrelated.

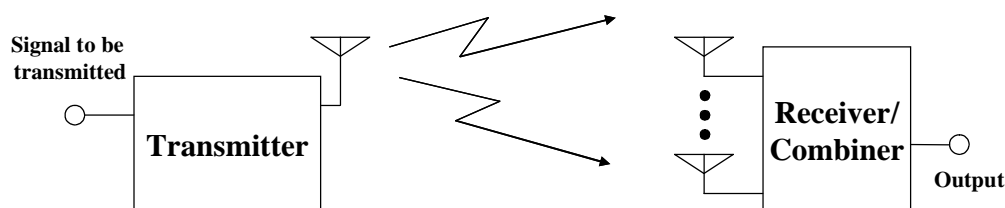

Figure 1.1.3.1: SIMO transmissions.

In subsequent paragraphs, we focus on Multiple Input Multiple Output (MIMO) techniques since cooperative communications have been initially presented as an alternative solution to MIMO transmission schemes.

1.2. MULTIPLE-INPUT MULTIPLE-OUTPUT (MIMO)

During the past decades, MIMO technology [Tela95] [FoGa98] has attracted attention in wireless communications, since it offers both of spatial diversity and multiplexing gain without requiring additional bandwidth or transmit power [Ilya03].

1.2.1. Properties of MIMO transmissions

Spatial diversity can be negotiated in two different ways according to the number of transmitted data streams.

When applied to a single data stream, the reception of several versions of the same emitted signal allows increasing the spatial diversity of the transmission. At the receiver, the signals received on the antennas are coherently combined in order to achieve a higher Signal to Noise Ratio (SNR) and hence, a better binary error probability P_b or a better Bit Error Rate (BER). In particular, in a Rayleigh fading channel, P_b for a Single Input Single Output (SISO) transmission decays like $(SNR)^{-1}$, P_b for a SIMO transmission scales like SNR^{-r} , where r denotes the number of receiving antennas (see the figure below). This property can be quantified in terms of increased diversity order. The diversity order of a transmission is defined in eqn. (1.2.1.1).

$$d = - \lim_{SNR \rightarrow +\infty} \frac{\log[P_b(SNR)]}{\log(SNR)} \quad (1.2.1.1)$$

In that case, when P_b decays like SNR^{-r} , the diversity order is r . The diversity order is basically the slope of the P_b curve in the high SNR regime when P_b is expressed in a logarithmic scale as shown in Fig.1.2.1.1. The full-line represents of SISO transmission ($r=1$) and the dot-line represents of SIMO transmission with two receiving antennas ($r=2$).

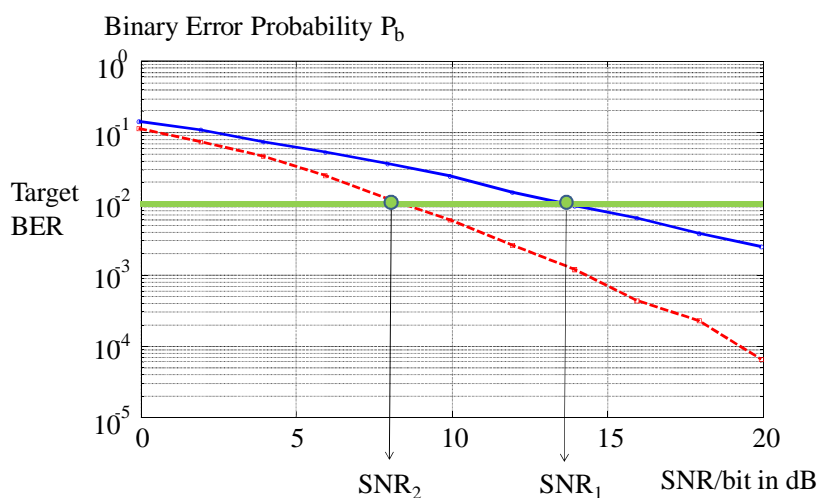

Figure 1.2.1.1: Binary error probability P_b curve in Rayleigh fading channel.

This property can be exploited in different ways. For instance, when SNR_1 denotes the required SNR in order to achieve a target BER in the SISO case, the required SNR in the SIMO case, denoted SNR_2 , is much lower than SNR_1 . This property allows for energy savings at the emitter side since the target BER is now achieved with a lower emitted power. The gain on the received SNR can also be used in order to increase the coverage area of the emitter.

Even if the BER is a largely used criterion, this indicator has a major drawback: it depends on the modulation scheme that is used to transmit the data. To avoid this dependence, another criterion is often used in this context: the outage probability. The outage probability p^{out} stands for the probability that the mutual information (I_D) of the transmission is less than a given spectral efficiency (R), as presented in eqn. (1.2.1.2)

$$P^{out} = \Pr[I_D < R] \quad (1.2.1.2)$$

When applied to several data streams, spatial diversity allows for the parallel transmission of all these data streams. Hence, the data rate of the overall transmission is increasing but the BER on each stream is the one of a SISO transmission. So the two objectives, robustness and increased throughput, cannot be achieved at the same time. Note that Space Time Codes (STCs) are used in order to orthogonally transmit the parallel data streams.

1.2.2. Limitations of MIMO transmissions

MIMO transmissions induce an additional cost due to the installation of multiple antennas on the terminals. Moreover, an additional processing time is required to process several emitted and/or received signals. But the major limitation of MIMO transmissions is due to the coherence distance D_c . Indeed, spatial diversity is achieved if and only if the received signals can be considered as being uncorrelated. And this property can only be achieved when the receiving antennas are spaced by the coherence distance at least. The coherence distance is on the order of $\lambda/2$, λ being the wavelength of the signals calculated by eqn. (1.2.2.1).

$$\lambda = \frac{c}{f_c} \quad (1.2.2.1)$$

c is a speed of light and f_c is the carrier frequency. For instance, in the frequency band of IEEE 802.11 wifi networks, the carrier frequency is chosen close to 2.4 GHz. So the space between antennas is on the order of 6 cm. This constraint may not be suitable for systems where the size of the wireless terminals should be minimized, e.g. sensor networks. In this context, cooperative communications provide an interesting alternative.

1.3. COOPERATIVE COMMUNICATIONS

Cooperative communications have been introduced by [SeEA03a] [SeEA03b] [LaTW04] and [NoHu04]. Cooperative communications provide an alternative form of spatial diversity. The concept of cooperative communications is to exploit the broadcast nature of the wireless medium by transforming single-antenna terminals into a virtual antenna array. Thus, multiple signals are transmitted from source and relay(s) terminals through uncorrelated channels to the destination and provide benefits of spatial diversity.

An example of single-relay cooperative scenarios is shown in Fig.1.3.1. When a source terminal S transmits a signal to a destination terminal D through its direct path (S-D), other terminals such as the relay terminal R can overhear the signal. So when terminal R is in a cooperative mode, it forwards the source message to the destination D. Thus, D receives two signals: the original one transmitted from S through the direct path (S-D) and the relayed one forwarded by R through the relayed path (S-R-D).

As a result, the two received signals at the destination terminal are combined to achieve a better spatial diversity compared to the one achieved with a single direct path. Note that more than one relay terminal can be deployed. Moreover, in this thesis, S and D can also represent a current terminal and next hop terminal in multi-hop networks.

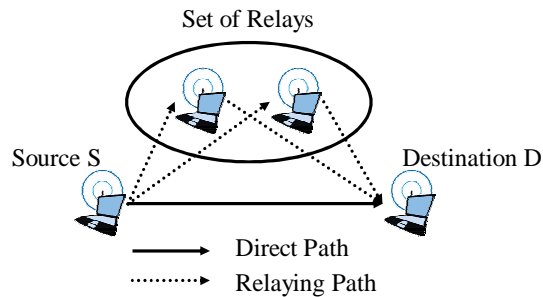

Figure 1.3.1: An example of cooperative scenario.

In multi-hop networks as shown in Fig.1.3.2, the cooperation can be used in any intermediate hop along the data transmission route. A relay terminal or a set of relay terminals helps on data relaying from a previous terminal to a next-hop terminal. In this thesis, the use of “a source terminal” can also refer to “a previous terminal” and “a destination terminal” can also refer to “a next-hop terminal”.

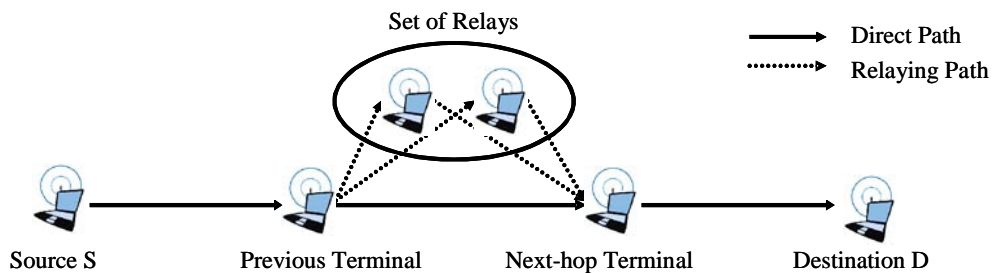

Figure 1.3.2: An example of cooperative scenario in multi-hop networks.

Cooperative communications have been implemented in several communication systems such as cellular networks [SeEA03a] and [SeEA03b], wireless local area networks (WLANs) [ZhZJ09], ad hoc networks [Lane02] and [LaWT04], mobile broadband radio networks [PWSF04], and cognitive radio networks [ZhJZ09]. In each communication system, cooperation scenarios have been designed compatibly with the natures of each network types; for example, centralize cooperative setup is proposed for cellular or wireless local area network (WLAN) networks while distributed ones are designed for in ad hoc and sensor networks.

1.3.1. Properties of Cooperative Communications

Spatial diversity is the main advantage provided by cooperative communications. This property can be expressed in terms of increased diversity order. For instance, Fig.1.3.1.1 presents a comparison of transmission schemes over Rayleigh channels. Rayleigh transmission is a typical model for wireless transmissions. The BER values are observed over a given range of E_b/N_0 ratios, where E_b/N_0 denotes the received SNR per bit. The dotted curve represents the performance for a direct transmission between a source terminal and a destination terminal (SISO case). The slope of the curve gives the diversity order of this transmission scheme. The diversity order of the direct transmission is one. The dashed curve represents the theoretical BER performance of a SIMO transmission with two receiving antennas. Hence, the diversity order is two, the number of receiving antennas. The curve with circles and the solid curve represent the performance of a simulated Amplify-and-Forward (AF) transmission and the theoretical performance of an AF transmission respectively. The AF transmission scheme is a cooperative transmission scheme. This cooperation scheme involves only one relay terminal. The figure shows that the AF transmission scheme achieves a diversity order of two. Note that the received power has been normalized to allow fair comparison, i.e. the destination terminal is always receiving the same power.

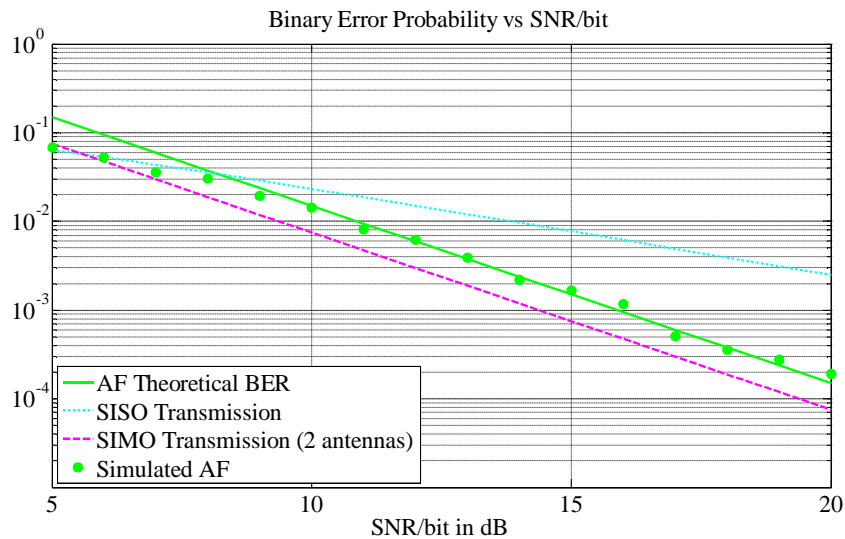

Figure 1.3.1.1: BER of cooperative and non-cooperative communications in Rayleigh fading channels.

Again, the gain in the diversity order achieved by a cooperative transmission can be used in order to lower the emitted power or in order to extend the range of the terminal.

1.3.2. Limitations of Cooperative Transmissions

Spatial diversity benefits come with some costs. Since at least one relay terminal retransmits the transmission overheard from a source terminal, cooperative transmissions are consuming more resource than a direct transmission. The resource can be expressed in terms of time slots, frequency bands, spreading codes, or space time codes.

Moreover, the implementation of cooperative communications implies additional design constraints so that cooperative transmissions do not interfere with other direct transmissions.

1.4. CONCLUSION

Multi-antenna MIMO techniques are largely used in order to provide spatial diversity in a wireless transmission between a source terminal and a destination terminal. Compared to single antenna transmissions, spatial diversity allows for the achievement of a target BER with a lower emitted power. However, the implementation of MIMO techniques ask for a space between antennas that is on the order of half the wavelength of the system. This condition is hard to fulfil in a context such as sensor networks and ad hoc networks. In this context, cooperative transmissions have been proposed as an alternative solution. The multi-antennas reception of a signal is emulated by the multiple transmissions of a same signal: one from the source terminal and other transmissions from relay terminals. Hence, several signals are received by the destination terminal, as if there were several antennas on the destination terminal. The following chapters present the major issues in the design of cooperative transmissions and cooperative setup.

Chapter 2

COOPERATIVE TRANSMISSION AT THE PHYSICAL LAYER

Contents

- 2.1. Forwarding schemes
 - 2.2. Cooperative Transmission Modes
 - 2.2.1. Fixed relaying
 - 2.2.2. Adaptive relaying
 - 2.3. Cooperation Scenarios
 - 2.4. Channel Access
 - 2.4.1. Multiplexing
 - 2.4.2. Channel access at the MAC layer
 - 2.4.3. Resource optimization, the coding issue
 - 2.5. System Parameters
 - 2.5.1. Relay locations
 - 2.5.2. Number of relay terminals
 - 2.5.3. Channel availability
 - 2.6. Conclusion
-

The basic concept of cooperative transmissions is to allow several single-antenna terminals to perform as a virtual multi-antenna terminal. In a scenario with a single relay terminal, an original signal and an uncorrelated redundant signal are respectively transmitted by a source terminal and a relay terminal. This cooperation scheme consumes more resource than a non-cooperative scheme. Therefore, the main issue in cooperative transmissions consists in both maximizing the spatial diversity and minimizing the resource consumption. This chapter present the basics of cooperative transmissions.

Chapter Organization

In the first part, forwarding schemes are presented in order to understand how relay terminals helps a source terminal on data relaying. Then, cooperative transmission modes are presented in order to provide an idea when the relay terminals have to work on cooperative data relaying. Since the source and relay terminals have to cooperatively

transmit data to the destination, channel access methods are described to present on how the resource are allocated among cooperative participating terminals . Finally, the system parameters that influence on the cooperative transmission performance are presented.

2.1. FORWARDING SCHEMES

In a cooperative scenario, a relay terminal (or a set of relay terminals) has to help a source terminal to forward data to a destination terminal. There are two common forwarding schemes that are used for data forwarding at a relay terminal: Amplify-and-Forward (AF) and Decode-and-Forward (DF). First, a system model is specified.

System model

We study the cooperative transmission between a source terminal S and a destination terminal D with the help of a relay terminal R. We consider a slow Rayleigh fading channel model. Our analysis focuses on the case of slow fading, to capture scenarios in which delay constraints are on the order of the channel coherence time. A half duplex constraint is imposed across each relay terminal, i.e. it cannot transmit and listen simultaneously. Moreover, transmissions are multiplexed in time, they use the same frequency band.

Let h_{ij} be the channel gain between a transmitting terminal i and a receiving terminal j . The channel gain h_{ij} captures the effects of path loss and Rayleigh fading. We consider scenarios in which each fading coefficient h_{ij} is accurately measured by the receiver j , but not known to the transmitter i . We also assume that the channel gain h_{ij} is identical to the channel gain h_{ji} . This assumption is relevant since both channels are using the same frequency band. Statistically, channel gains h_{ij} between any two pair of terminals i and j are modelled as independent and identically distributed (i.i.d.) circularly symmetric complex Gaussian random variables with zero mean and equal variance σ^2 . Let P be the power transmitted by each terminal and σ_w^2 be the variance of the AWGN (Additive White Gaussian Noise) in the wireless channel. We define $SNR=P/\sigma_w^2$ to be the effective signal-to-noise ratio.

We also restrict our study to a single source-destination pair and we assume that the relay terminal has already been allocated to the source-destination transmission. Moreover, the relay terminal R is not involved in any other transmission.

Amplify-and-forward (AF)

In this scheme, the relay terminal amplifies the received signal from a source terminal and forwards it to a destination terminal, as shown in Fig.2.1.1a. This technique has been considered in [IsKr09], [ChCY08], and [NiQB06] for examples.

We use a base-band-equivalent, discrete-time channel model for the continuous-time channel. Three discrete time received signals are defined in the following. Here, $y_{ij}(n)$ denotes the signal received by terminal j and transmitted by terminal i . During the first time-slot, D and the relay terminal R are receiving signals from S. The received signal at D and R sent by S are shown in eqn. (2.1.1) and (2.1.2) respectively.

$$y_{SD}(n) = h_{SD}x(n) + w_{SD}(n) \quad (2.1.1)$$

$$y_{SR}(n) = h_{SR}x(n) + w_{SR}(n) \quad (2.1.2)$$

for $n=1,2,\dots,T_M/2$, where T_M denotes the duration of time-slots reserved for each message. During the second time-slot, the relay terminal R transmits a new signal using a fixed AF scheme. The received signal at D sent by R is shown in eqn. (2.1.3).

$$y_{RD}(n) = h_{RD}\beta y_{SR}(n) + w_{RD}(n) \quad (2.1.3)$$

for $n= T_M /2+1,\dots, T_M$. The noise $w_{ij}(n)$ between transmitting terminal i and receiving terminal j are all assumed to be independent and identically distributed (i.i.d.) circularly symmetric complex Gaussian with zero mean and variance σ_w^2 . Symbols transmitted by the source terminal S are denoted $x(n)$. For simplicity, we impose the same power constraint at both the source and the relay: $E\{|x(n)|^2\} \leq P$ and $E\{|\beta y_{SR}(n)|^2\} \leq P$. We implement a fixed AF cooperation scheme. So the normalization factor β must satisfy eqn. (2.1.4)

$$\beta = P / (|h_{SR}|^2 P + \sigma_w^2) \quad (2.1.4)$$

We assume that the source and the relay each transmit orthogonally on half of the time-slots. We also consider that a perfect synchronization is provided at the block, carrier, and symbol level.

Decode-and-forward (DF)

Instead of being amplified, the received signal transmitted by the source terminal is decoded at the relay terminal. Then, the relay re-encodes the data, and forwards it to the destination terminal, as shown in Fig.2.1.1b. These techniques have been introduced by [SeEA03a] [SeEA03b] and [BCGH06].

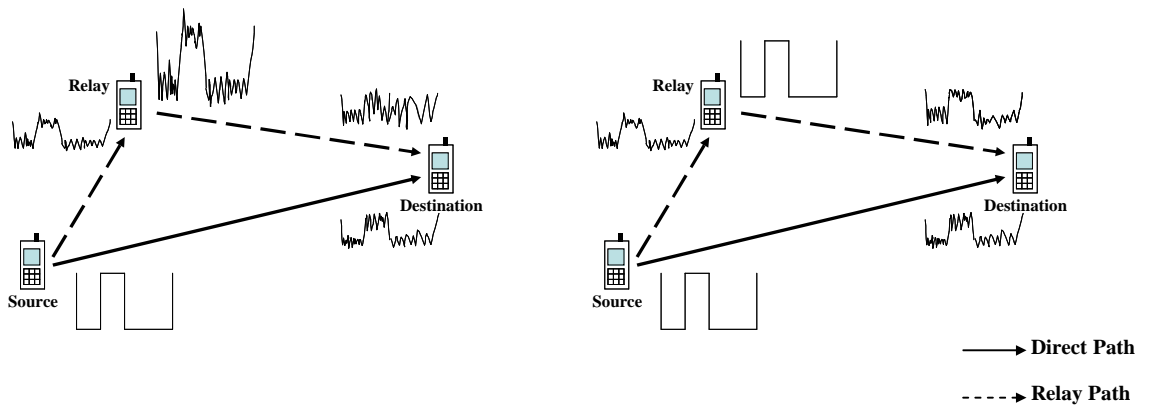

Figure 2.1.1: Forwarding schemes (a) Amplify-and-Forward: AF and (b) Decode-and-Forward: DF.

So, during the second time-slot, the received signal at D sent by R is shown in eqn. (2.1.5).

$$y_{RD}(n) = h_{RD}\hat{x}(n) + w_{RD}(n) \quad (2.1.5)$$

where $\hat{x}(n)$ denotes the estimate of $x(n)$.

Optimal Receiver at the signal level

The optimal receiver implements a Maximum Ratio Combiner (MRC). This approach maximizes the signal to noise ratio at the receiver so the BER is minimized. More particularly, the receiver is computing the following signals for an AF optimal receiver, given the two received signals $y_{SD}(n)$ and $y_{RD}(n)$ as shown in eqn. (2.1.6) and (2.1.7).

$$r_{SD}(n) = h_{SD}^* y_{SD}(n) \quad (2.1.6)$$

$$r_{RD}(n) = (h_{RD}\beta h_{SR})^* y_{RD}(n) \quad (2.1.7)$$

The following expressions shown in eqn. (2.1.8) and (2.1.9) are for the DF optimal receiver.

$$r_{SD}(n) = h_{SD}^* y_{SD}(n) \quad (2.1.8)$$

$$r_{RD}(n) = h_{RD}^* y_{RD}(n) \quad (2.1.9)$$

For any transmission scheme, the decision on the bit transmitted at time n is taken according to the observation $r_D(n)$ in eqn. (2.1.10)

$$r_D(n) = r_{SD}(n) + r_{RD}(n) \quad (2.1.10)$$

Sub-optimal techniques may be used, such as equal gain combining (EGC) and selection combining (SC). These techniques provide a trade off between optimality and complexity.

Performance of AF and DF transmission schemes

The performance parameters that are used to characterize cooperative communications are related to the notion of spatial diversity. So, just like in the MIMO area, performance indicators such as BER, outage probability, and diversity order are commonly used in this domain. Again, even if the performance of a transmission scheme is characterized by an increased diversity order, it should be noted that this advantage can be converted into many ways: lower emitted power and extended coverage area.

Fig.2.1.2 and 2.1.3 respectively show the performance of the AF and DF transmission scheme for the system model as presented previously. Performance is expressed in terms of Bit Error Rate (BER) with respect to the signal to noise ratio per bit. The modulation scheme used is a BPSK (Binary Phase Shift Keying) modulation. Data bits are transmitted until that one hundred errors have been experienced.

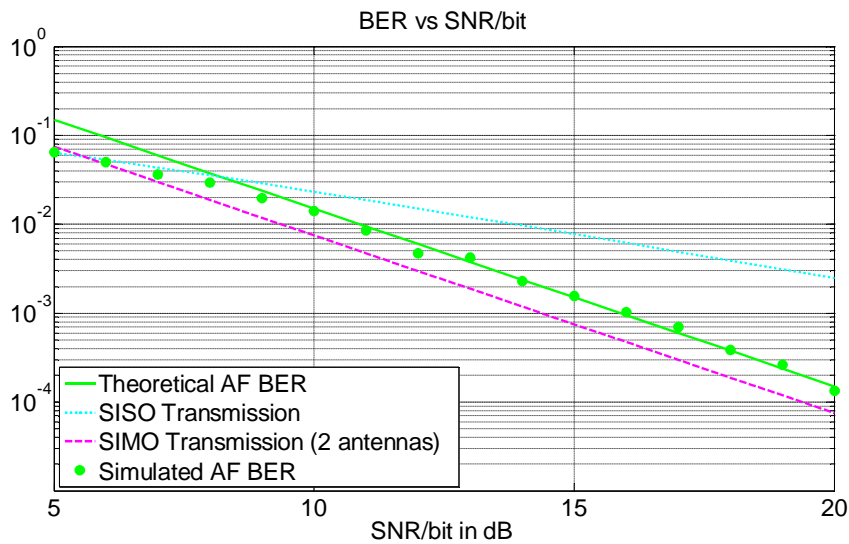

Figure 2.1.2: The performance of the AF transmission scheme.

The AF curves show that the diversity order of the AF transmission scheme is two, i.e. the spatial diversity of an AF cooperative scheme is similar to the one achieved when the destination terminal has two receiving antennas. However, the BER of the AF scheme is higher than the one of a SIMO transmission with two antennas. This is due to the fact that the AF transmission scheme is forwarding AWGN noise in the relay-destination channel.

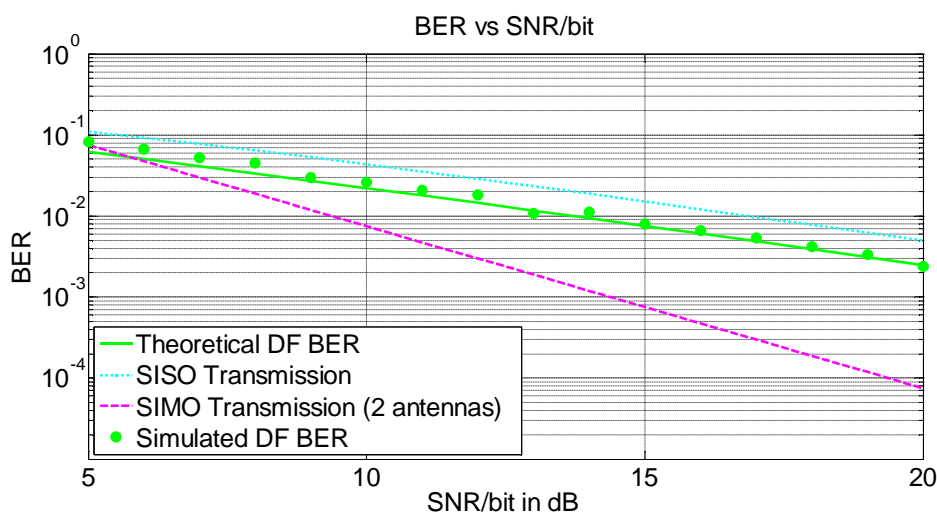

Figure 2.1.3: The performance of the DF transmission scheme.

The DF curves show that the diversity order of the DF transmission scheme is one, i.e. the spatial diversity of a DF cooperative scheme is similar to the one achieved with a direct transmission. There is no improvement on the diversity order compared to a direct transmission. This is due to the fact that the DF transmission scheme is sometimes forwarding errors in the relay-destination channel. The performance of the overall transmission scheme is dominated by the performance of the source-relay channel.

Optimal receiver at the bit level

Instead of combining the two received signals, namely $r_{SD}(n)$ and $r_{RD}(n)$, separate decisions are made on each signal. Hence, two bit streams are estimated: one from the signal transmitted by S and one from the signal transmitted by R. Then, error correcting decoders are used to combine the two bit streams. Indeed, physical layer standards are all implementing error correcting codes. Data are encoded with a given code parameterized by the code rate $R_c=k/n$, where k denotes the number of bits at the encoder input and n is the number of bits at the encode output. When a single bit stream is decoded at the receiver, a R_c code rate decoder is used. When two bit streams are jointly decoded at the receiver, a $R_c/2$ code rate decoder is used. Since the performance of an error correcting code is directly related to the amount of redundant data, the $R_c/2$ code rate decoder will perform better than the R_c code rate one. This combination scheme is called Chase combining and is used in HARQ (Hybrid Automatic Repeat reQuest) mechanisms [ODHJ03] and [JLLC09] in order to combine several retransmissions of the same frame.

Comparison of AF and DF cooperation schemes

The advantage of the AF scheme over the DF scheme is that it consumes less processing time since the decoding and re-encoding processes are not required at the relay terminal. However, as shown in Fig.2.1.1a, the noise from source-to-relay channel is also amplified and is forwarded from the relay terminal to the destination terminal. This noise can cause performance degradations in term of bit error rate.

The advantage of the DF scheme over the AF scheme is that the noise from source-to-relay channel is not forwarded to the destination. However, if the channel quality of the source-to-relay channel is not good enough, decoding errors at a relay terminal are forwarded and cause errors on the decoding processes at the destination terminal. The performance of AF in terms of BER or outage probability is better than the one of DF, despite the noise that is amplified and forwarded [BoFY04].

2.2. COOPERATIVE TRANSMISSION MODES

Once a cooperative transmission technique has been selected, the cooperative transmission protocol should also decide whether a relay must always forward the source message or not. When the relay always forwards the source message, we refer this option as fixed relaying. Other options include adaptive relaying schemes such as selective relaying and on-demand relaying.

2.2.1. Fixed relaying

In a fixed relaying scenario, relay terminals are always relaying the source message. So resource should always be assigned to relay transmissions. Examples of fixed cooperative mode utilization can be found in [BoFY04] [LaTW04]. Note that when using a DF transmission scheme, the source message is always forwarded by the relay terminal, even if the message has been received with errors. Error propagation is the main drawback in a fixed DF transmission scheme. That is the reason why the diversity order of this transmissions scheme is limited to the value of one.

2.2.2. Adaptive relaying

In an adaptive relaying scenario, relay terminals are not always relaying the source message. The decision on whether to forward the source message or not is made depending on some extra information on the context. Examples of adaptive relaying are selective relaying and on-demand relaying.

Selective relaying

The relay terminal may choose not to transmit the source message. The decision may be based on channel measurements such as signal-to-noise ratios [BCGH06], or fading gains estimates [LaTW04]. When the parameter lies above an operating threshold, the relaying is activated. Otherwise, the relay remains silent. A similar approach consists in checking the control field of the source message. When the Cyclic Redundancy Check (CRC) is correct, the source message is forwarded. Otherwise, the relay remains silent. The decision can also be based on either local information such as remaining power and queue length, or global information transmitted by other terminals. Typically, selective DF performs much better than a fixed DF scheme. A selective DF scheme is achieving a diversity order of two.

In that context, an issue arises on what to do with the unused resource (e.g., time-slot and frequency band) when it has been decided that the relay should not transmit. The resource is lost when the resource allocation process is static and resource has already been assigned to relay transmissions. This can happens when cooperative transmissions are dealt with at the physical layer. Otherwise, the released resource can be used for another purpose, maybe another source transmission. This can happens when cooperative transmissions are dealt with at the upper layers. Examples of adaptive cooperative transmission protocols can be found in [LiTP05] and [PPER09]. Cooperative transmission mode is only turned on by the relay terminal when system performance can be improved by cooperative transmissions. To get this knowledge, the transmission of additional signaling information among terminals is usually required. For instance, an additional control frame called a Helper Ready to Send (HTS) is used in [LiTP05] in order to activate cooperative transmission mode. If the relay path (source-relay-destination) can provide higher data rate than the direct path (source-destination), the HTS frame is sent by the relay terminal to inform the source terminal and destination terminal that the cooperative transmission mode is turned on.

On-demand relaying

Cooperative transmissions can also be initiated when needed, when the destination fails in decoding the source message, for instance. Examples of on-demand cooperative transmission protocols can be found in [LaTW04] and [GZVP07]. In [LaTW04], an on-demand cooperative protocol named incremental relaying protocol has been proposed. A negative acknowledgement (NACK) of automatic repeat request (ARQ) protocol has been proposed to work as a cooperative request and is sent from a destination terminal. While in [GZVP07], an additional control frame called Claim for Cooperation (CFC) is used as a cooperative request and is sent by a destination terminal to its neighbour terminals (also called potential relay terminals).

Based on cooperative forwarding schemes as mentioned above, the selective DF scheme with adaptive relaying provides a diversity order of two with resource efficiency; thus, this forwarding scheme is interesting for our cooperative transmission design.

2.3 COOPERATION SCENARIOS

Cooperative communications have been implemented in several communication systems such as cellular networks [SeEA03a] and [SeEA03b], ad hoc networks [Lane02] and [LaWT04], mobile broadband radio networks [PWSF04], and cognitive radio networks [ZhJZ09].

In each case, cooperation scenarios have been designed compatibly with the natures of each network types; for example, centralized cooperative setup methods are proposed for cellular or wireless LAN networks while distributed ones are designed for in ad hoc and sensor networks.

For instance, some approaches minimized the resource consumption by allowing the source terminal to forward the relay message [SeEA03a], [SeEA03b], and [LaTW04]. This can happen in the context of cellular networks and wireless LANs, where the destination terminal is the base station or the access point (see Fig.2.3.1 and 2.3.2). Hence, the source terminal and the relay terminal may be two end-user terminals having data to send to the base station or the access point. In that context, the relay terminal helps the source terminal, and inversely the source terminal helps the relay terminal. Actually, there is no more a source terminal and a relay terminal but two source terminals instead.

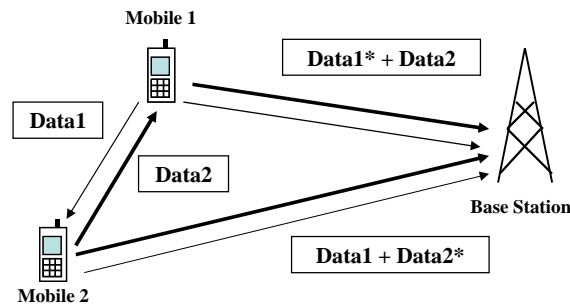

Figure 2.3.1: An example of the symmetric cooperation in a cellular network.

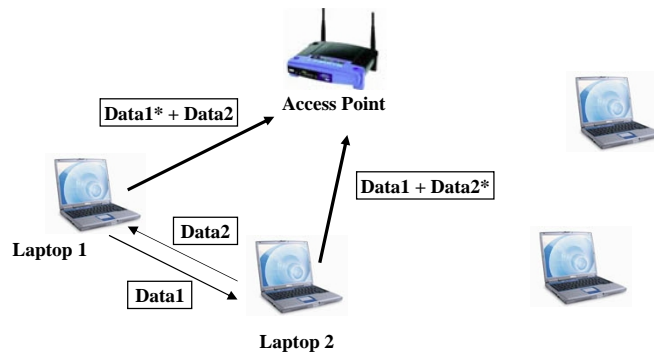

Figure 2.3.2: An example of the symmetric cooperation in a wireless LAN.

2.4. CHANNEL ACCESS

The main limitation of cooperative communications is the resource consumption. Indeed, a cooperative transmission consumes more resource than a direct non-cooperative transmission since there are at least two transmissions: the one from the source terminal and the one from the relay terminal. This is due to that fact that these two transmissions should not interfere. Thus, they should take place on two orthogonal, non-interfering channels. This is a channel access issue. The channel access is generally processed at the MAC layer since cooperation needs a dynamic resource allocation process. But this issue can also be addressed at the physical layer when the resource allocation is rather static. Allocating resource is then referred to as a multiplexing issue.

2.4.1. Multiplexing issues

The source signal and the relay signal should not interfere. These signals should be transmitted over orthogonal channels. Orthogonality can be provided in many ways.

Time-division multiplexing

The most straightforward method to allow source and relay terminals to transmit data orthogonally is the separation in time, called time-division multiplexing. The original data and relayed data are transmitted in non-overlapping time intervals.

Frequency-division multiplexing

For the frequency-division multiplexing technique, the idea is to transmit original and relayed data using separated carrier frequencies. This idea is suitable for cellular systems because the frequency band of the uplink is separated into small frequency channels. Therefore, the source terminal and relay terminal(s) can cooperately transmit their data to the base station in different frequency channels. However, this idea is not suitable for ad hoc wireless networks since all mobile terminals use the same frequency band.

Code-division multiplexing

In [SeEA03a], [SeEA03b], and [AzAA05], the orthogonality between source and relay terminals is achieved via spreading codes, just like in CDMA (Code Division Multiple Access) systems.

Space time coding

Transmit diversity can be achieved using space time codes. In typical scenarios, space time codes allow the transmissions of orthogonal versions of a same signal over several transmit antennas. When these antennas are distributed over several single antenna relay terminals, the same amount of spatial diversity can be achieved. Note that distributing space time codes on each terminal is resource consuming and that an additional amount of resource is necessary for orthogonal transmission when the number of terminals exceeds two [[BrCG01]], [JHHN04], and [LaWo03].

2.4.2. Channel access at the MAC layer

Resource can be allocated dynamically among cooperating terminals according to a MAC layer protocol. For instance, signaling approaches like the RTS/CTS (Ready-to-Send/Clear-To-Send) handshake for IEEE 802.11-based wireless networks can be implemented in order to enable the transmission of relay terminal [ChYW07], [AzAA05], and [LTNK07].

2.4.3. Resource optimization, the coding issue

Additional resource is consumed in order to enable cooperation among terminals. Usually, relays terminals repeat the source message using an extra time-slot or a different frequency band. Two coding techniques can reduce the amount of resource that is consumed during cooperation: the first one is related to error correcting codes and the second one is related to network coding.

Error Correcting Codes

From a coding point of view, repeating information is not an efficient transmission method. Indeed, repetition codes are known to have bad performance compared to any other codes. Based of this observation, many optimization opportunities arise. In the area of coded cooperation, the relay terminal sends a modified version of the source message.

For instance, when the source terminal encodes its data frame with punctured convolutional codes, different groups of parity bits are generated. The source terminal may send the data frame with a first group of parity bits and the relay terminal can send the second group of parity bits. Since the amount of redundancy is usually lower than the amount of data, this approach achieves resource optimization. Note that this approach is similar to the one implemented in the incremental redundancy method of the HARQ mechanism. Several other implementations have been proposed in [LiSS08], [StEr04], and [HuNo06].

Network coding

Network coding was introduced in 2000 by R. Ahlswede et al. [ACLY00]. Instead of simply forwarding data, terminals may combine several input data packets into one or several output data packets in order to reduce the number of data transmissions. Therefore, system performance in term of throughput, delay, and energy consumption is beneficial [PeFL08]. A simple network coding example in half-duplex channels with a time-division duplex (TDD) is shown in Fig.2.4.1. Terminal A and B would like to communicate to each other and they have to exchange their data packets through terminal R, which is an intermediate terminal in ad-hoc networks or a base station in cellular systems. For a traditional transmission method, terminal A and B respectively transmit their data packets (“a” and “b”) to terminal R. Then, terminal R forwards data packets “a” and “b” to terminal B and A in sequence, as shown in Fig.2.4.1a. By implementing a network coding technique as shown in Fig.2.4.1b, after R receives data packets “a” and “b” sent by terminal A and B, “a xor b” is broadcasted to both of terminal A and B at the same time. The xor is an exclusive or operation. For the result, both of terminal A and B can recover the packet of interest, while the number of transmission is reduced.

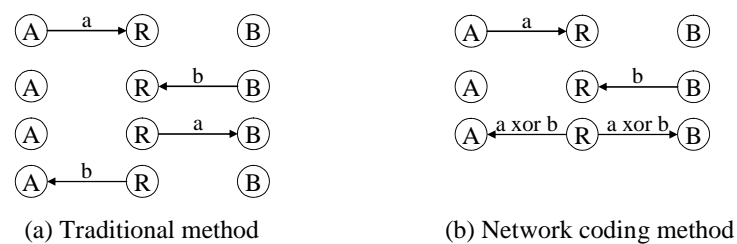

Figure 2.4.1: A simple network coding example.

The idea of network coding has been widely used in cooperative transmissions such as in [PeFL08], [ZhCi08], [SuLW09], [WaLW09], [WHLP08], [MeMe09], and [DiRL09]. It has been implemented in a cellular network [SuLW09], as shown in Fig.2.4.2. Terminal A and B are source terminals that would like to transmit their data (denoted as “a” and “b” respective) to the same base station through half-duplex channels with a time-division duplex (TDD). Instead of using two relay terminals (R1 and R2 as shown in Fig.2.4.2a) to relay data from source terminals A and B to a base station as in a traditional relay cooperative system, a single relay is used for two source terminals A and B in a

cooperative system with network coding technique as shown in Fig.2.4.2b. The relayed data transmitted from R can be “a xor b” or a combination of incremental redundancy frames of A and B resulted from a channel coding technique. The xor stands for an exclusive or operation.

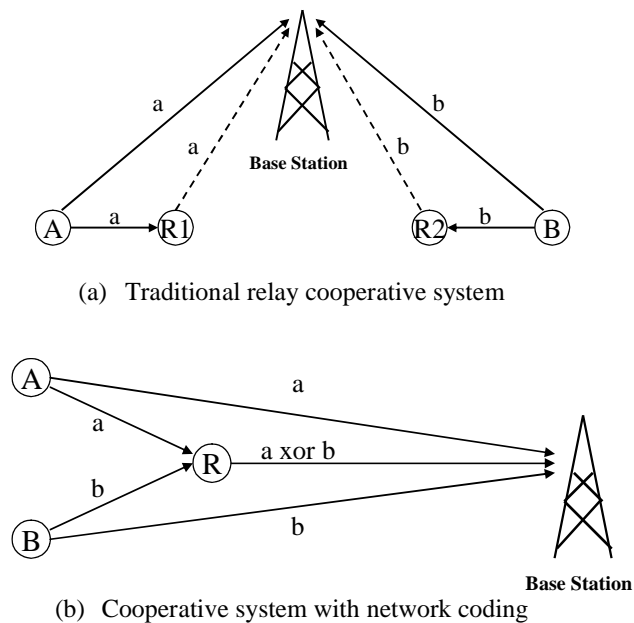

Figure 2.4.2: (a) Traditional relay cooperative system and (b) Cooperative system with network coding in a cellular network.

Network coding techniques have also been implemented in ad-hoc networks, [WaLW09] for example. Terminal A and B would like to communicate to each other and terminal R is their relay terminal. In phase (1), A transmits its data (a) to B and R. Then, in phase (2), B transmits its data (b) to A and R. Finally, in phase (3), R broadcasts “a xor b” to A and B as shown in Fig.2.4.3.

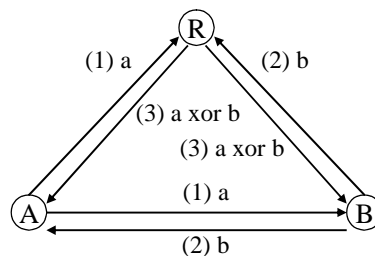

Figure 2.4.3: Cooperative system with network coding in an ad-hoc network.

2.5. SYSTEM PARAMETERS

Apart from the trade off between spatial diversity and resource consumption, other parameters such as relay locations, the number of relays, and the channel availability may influence the performance of cooperative transmissions.

2.5.1. Relay locations

Fading channels are modelled using a channel gain that multiplies the emitted signal. This gain is a random variable with three components representing three loss types: a free-space loss, a shadowing factor and a Rayleigh gain. The first coefficient depends on the distance between terminals; the second factor depends on the environment of the terminals (presence of obstacles). Spatial diversity is generally studied assuming Rayleigh paths with identical statistical characteristics like mean and variance. Basically, this assumes equal distance between terminals. So when the channel model includes both the Rayleigh gain and the free-space loss, optimization opportunities depending on the distance arise.

In [BoFY04], the effects of relay positions on the performance of cooperative transmissions with AF and DF schemes have been studied. Cooperative transmissions with amplify-and-forward (AF) scheme reach optimal performance in terms of BER when the relay locates near the destination terminal. Indeed, in power constrained conditions, when the distance of R-D decreases, a smaller percentage of the total allocated power is required at the relay terminal. Thus, the source terminal can transmit with greater power and yields better signal quality at the relay and destination terminals.

In contrast to AF, cooperative transmissions with decode-and-forward (DF) transmission yields its best performance when the relay is located closed to the source terminal or when the channel quality of S-R is high. The BER of DF increases when the distance between S-R increases or when the channel quality of S-R drops. This drawback happens because the relay terminal may send erroneous bits to the destination. Basically, when D is receiving a true bit from S and a wrong bit from R, the resulting BER is 0.5 in average. These results attest that the relay position should be concerned in relay terminal(s) selection processes.

2.5.2. Number of relay terminals

It can be shown that the error probability on Rayleigh fading channels scales like SNR^{-K} , where K is the number of transmitting terminals, i.e. source and relay terminals. This means that cooperative communication takes more advantage from spatial diversity when it deploys more relay terminals. However, since the wireless medium (whether in time, frequency, or codes) is shared among cooperative participating terminals (i.e. source, relays, and destination terminals), cooperative transmissions consume more medium when the number of relays increases.

2.5.3. Channel availability

If the network has high density of active terminals, i.e. terminals that have their own data to transmit, there is a high demand for medium access. Therefore, relay terminals have to compete with those active terminals to acquire the medium. This causes collisions and possible delays to the network. Thus, the use of cooperative mode must also consider the channel availability.

2.6. CONCLUSION

In this chapter, we have presented the basics of cooperative transmissions. The design of cooperative transmissions mainly focuses on how to transmit, to relay, and to receive data. When cooperative communications are implemented in real networks based on a stack of protocols, cooperative transmissions are dealt with at the physical layer. Indeed, the physical layer is in charge of forwarding schemes, cooperation modes, multiplexing and signal combination issues.

It has been noticed that resource consumption was the main limitation of cooperative transmissions. A dynamic resource allocation should provide many optimization opportunities on that topic. This issue is usually not dealt with at the physical layer, but rather at upper layers. In particular, MAC layer protocols are often responsible for resource allocation. So the complete design of a cooperative network should also include MAC concerns to address the resource allocation issue. Moreover, it has been assumed that relay terminals have been already assigned to a given source-destination pair, up to now. The assignation process should also be addressed at upper layers. We call these configuration issues “*cooperative setup*” [AzAA05], [BISW07], [ChYW07], [GZVP07], and [LTNK07].

Chapter 3

COOPERATIVE SETUP ANALYSIS

Content

- 3.1. Cooperative Setup in the MAC Layer
 - 3.1.1. IEEE 802.11 MAC standard
 - 3.1.2. Distributed relay selections
 - Distributed cooperative MAC for multihop wireless networks (DCM) [ShZW09]
 - 3.1.3. Centralized relay selections
 - CoopMAC: A cooperative MAC for Wireless LANs [LTNK07]
 - 3.1.4. Conclusion of cooperative setup in the MAC layer
 - 3.2. Cooperative Setup in the Network Layer
 - 3.2.1. Cooperative setup in the network layer mainly concerns with relay selections
 - Cooperative Routing and Power Allocation in Ad-hoc Networks [YaLH05]
 - 3.2.2. Cooperative setup in the network layer with all details of cooperative setup
 - Ad Hoc Cooperative Routing Algorithm Based on Optimal Channel Selection (ACR) [ChZZ06]
 - 3.2.3. Conclusion of cooperative setup in the network layer
 - 3.3. Comparisons of Cooperative Setup in the MAC Layer and the Network Layer
 - 3.4. Conclusion
-

The previous chapter concerns the concept of cooperative communications that have been firstly introduced and developed in a cooperative transmission research area. Cooperative transmissions focus only on transmission designs and how to acquire benefits of spatial diversity based on information theory. Thus, cooperative transmissions have been extensively proposed in the physical layer, [SEA03a] [SEA03b] and [JHHN04] for examples, in order to improve their transmission performance.

However, issues on inter-layer interaction between cooperative transmissions in the physical layer to protocols in the upper layers (especially the MAC layer and the network layer) have not yet been considered. These issues have lately been considered by modern

cooperative communication researches and, in this thesis, they are called “*cooperative setup*” topics. There are many questions in these contexts that have to be answered.

- *How terminals know that they have to participate in cooperative setup process?*
- *How to choose a relay terminal (or a set of relay terminals)?*
- *How the chosen relay terminal and other terminals know that which terminal is chosen as a relay terminal?*
- *How the source terminal and the relay terminal know their transmission sequence when they work in cooperative transmission mode?*

However, to our knowledge, there is not any common framework for cooperative setup design yet. Each cooperative setup protocol proposes its cooperative setup functions concerning to different issues on cooperative setup. Thus, the objective of this chapter is to observe and to categorize the literature on *what* and *how* cooperative setup functions have been considered in each cooperative setup protocol. Then, the analyses on the advantages and disadvantages of each type of cooperative setup protocol will be presented.

In this thesis, each question on cooperative setup is considered and categorized as follows.

- *How terminals know that they have to participate in cooperative setup process?*
The cooperative setup function concerning to this issue will be considered as a ***Cooperative activation process***.
- *How the relay terminal(s) is/are chosen?*
This cooperative setup function is called a ***Relay selection algorithm***. Relay selections are done based on any information in order to confirm that the selected relay terminal will provide better performance for the systems. Therefore, an ***Acquisition process*** should be concerned in order to provide information for the relay selection algorithm.
- *How the chosen relay terminal and other terminals know that which terminal is chosen as a relay terminal?*
A cooperative setup function will be considered as a ***Cooperative notification*** method.
- *How the source terminal and the relay terminal know their transmission sequence when they work in cooperative transmission mode?*
A cooperative setup function related to this issue is called a ***Resource allocation*** method.

In the following part of this chapter, we will present some examples of cooperative setup protocols. The selected cooperative setup protocols are specified at different levels of the protocol stack: the MAC layer and the Network layer. Details and advantages of the two basic methods of relay selections in cooperative setup: a centralized relay selection method and a distributed one will be presented. In addition, the interest of the presented

protocols in term of cooperation achievements through two different transmission methods; i.e., connection-oriented (per flow basis) and connectionless (per frame basis) transmission methods, will be described.

Chapter Organisation

The first section of the chapter is devoted to the cooperative setup in the MAC layer. After the presentation of the IEEE 802.11 MAC protocol, two examples of cooperative setup protocols are described. They are representatives of the various patterns of the literature concerning with relay selection methods and cooperative transmission modes. The first example is a cooperative setup protocol with a distributed relay selection method, which has been designed to work with connectionless transmission methods. The second example is a cooperative setup protocol with a centralized relay selection method, which has been designed to work with connection-oriented transmission methods. Finally, the advantages and disadvantages of cooperative setup in the MAC layer will be presented.

The second section concerns the cooperative setup in the network layer. The literature proposes mainly cooperative routing protocols that deal only with the relay selections. Details of cooperative setup in other aspects such as cooperative activations, cooperative notifications, and resource allocations have generally been neglected. However, there are a few protocols, which take these issues into account but they are cross-layer methods. In this part, an example of cooperative setup in the network layer has been chosen to be described. Its relay selection is done at the network layer, while the cooperative activation, the cooperative notification, and the resource allocation have done in other layers. Finally, the advantages and disadvantages of cooperative setup in the network layer will be analysed.

3.1. COOPERATIVE SETUP IN THE MAC LAYER

The main purposes of cooperative setup in the MAC layer are to allocate the resources and to setup cooperative environment among cooperative participating terminals. The participating terminals exchange information in order to decide on the cooperation and assign a relay (or a set of relay) terminal. The MAC exchanges are generally based of the IEEE 802.11 standard.

3.1.1. IEEE 802.11 MAC Standard

For interoperability issues, cooperative setup in the MAC layer has been extensively designed based on IEEE 802.11 MAC standard [IEEE07].

Basic of the IEEE 802.11 MAC Standard

In IEEE 802.11 standard, there are two major coordinate functions; Point Coordinate Function (PCF) and Distributed Coordinate Function (DCF). The PCF suits for infrastructure networks. The DCF is more flexible since it can be used within both of independent basic service set and infrastructure network configurations. Thus, DCF access method has been widely used in cooperative communication researches and also in our research. Details of the DCF are presented as follows.

The basic access mechanism of DCF is a Carrier Sense Multiple Access with Collision Avoidance (CSMA/CA). A terminal willing to transmit senses the medium. If the medium is busy, then it defers. If the medium is free for a specified time (called DIFS, Distributed Inter Frame Space), then the station is allowed to transmit. If the data are successfully received by the receiving terminal, an acknowledgement (ACK) frame is sent back to the transmitting terminal after a Short Inter Frame Space (SIFS) as shown in Fig.3.1.1.1. Reception of the ACK indicates the transmitting terminal that no collision occurred and that the data have been successfully received by the receiving terminal. Then, the transmitting terminal senses the medium again in order to transmit its next data frame. If the transmitting terminal does not receive the ACK before its transmission timeout reaches to zero, a re-transmission is required. This access method is called a basic access method or two-way handshaking (Data/ACK).

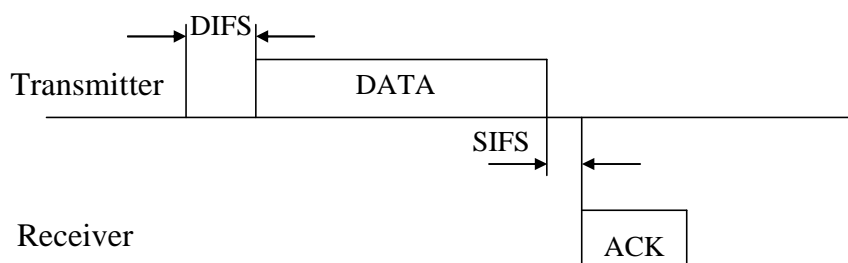

Figure 3.1.1.1: Basic access method of the IEEE 802.11 MAC standard.

Hidden Terminal Problems

However, a hidden terminal problem as shown in Fig.3.1.1.2 can be occurred when two transmitting terminals (S1 and S2) cannot hear each other. Therefore, in order to alleviate the collision probability, an optional access method or four-way handshaking (RTS/CTS/Data/ACK) as shown in Fig.3.1.1.3 has been proposed.

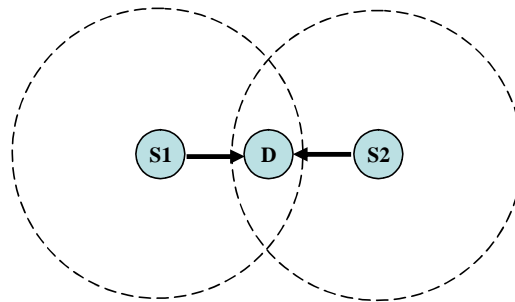

Figure 3.1.1.2: Hidden terminal problem.

A terminal willing to transmit data will first transmit a short control frame called Request To Send (RTS) to a receiving terminal. The receiver replies a response control frame called a Clear To Send (CTS) frame back to the transmitter. Other terminals receiving either RTS and/or CTS will defer their transmissions with the duration indicated in RTS and/or CTS frames called Network Allocation Vector (NAV). Based on Fig.3.1.1.2, the optional access method reduces the collision probability since the CTS frame that D has replied to S1 allows S2, which is hidden from S1, to know that D is busy.

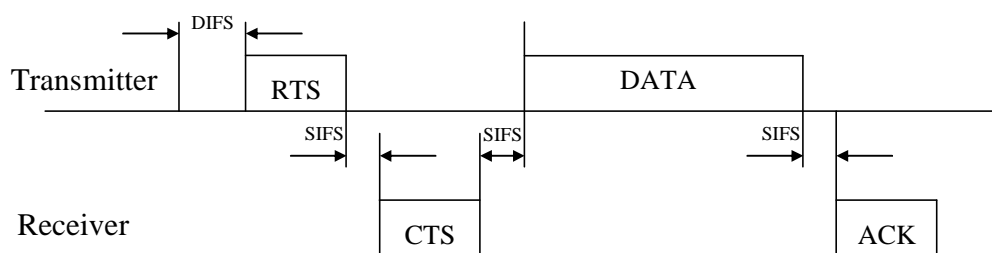

Figure 3.1.1.3: Optional access method of the IEEE 802.11 MAC standard.

It has to be noted that the RTS/CTS mode is an optional mode in the IEEE 802.11 MAC standard that is generally not used as it consumes more power than the mode without RTS/CTS frames (i.e., basic mode). In addition, the IEEE 802.11 MAC standard indicates that the RTS/CTS mechanism needs not to be used for every data frame

transmission especially for short data frames since RTS/CTS frames cause overhead inefficiency to the systems.

IEEE 802.11 and Cooperation Challenges

Some modifications have been done to implement cooperative setup processes on the standard. In cooperative transmission, a relay terminal has to help a source terminal on data relaying and thus also to access to the medium. The relayed data are sent after the original one. Fig.3.1.1.4 shows an example of cooperative transmission methods. The message flows of cooperative transmission based on IEEE 802.11 MAC standard in basic access method and in optional access method are shown in Fig.3.1.1.4a and Fig.3.1.1.4b, respectively. As shown in the figures, the message flows of IEEE 802.11 MAC protocol when it works in cooperative transmission mode are changed. Thus, when cooperative concept has been implemented, adaptations in the MAC protocol must be concerned.

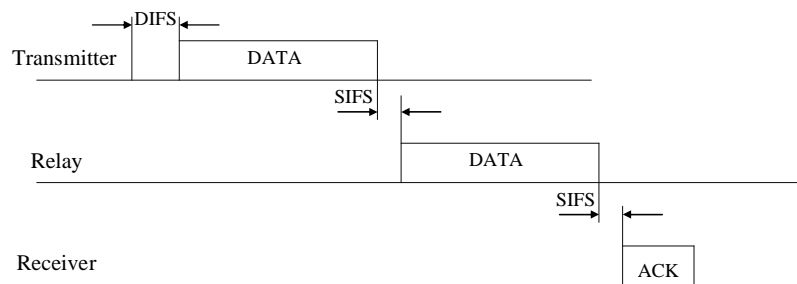

(a) Cooperative transmission in basic access method.

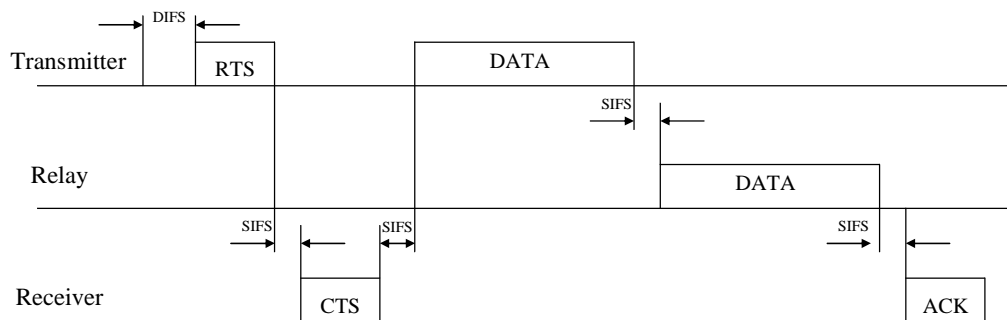

(b) Cooperative transmission in optional access method.

Figure 3.1.1.4: Message flows of cooperative transmission based on IEEE 802.11 MAC standard in (a) basic access method and in (b) optional access method.

Hidden Terminal Problems in Cooperative Communications

The hidden terminal problem is more severe in cooperative communications. Whether the optional access method (RTS/CTS mode) has been designed to alleviate hidden terminal

problems, hidden terminal problems must be re-concerned when cooperative concept has been implemented.

Fig.3.1.1.5 shows an example of hidden terminal problems in cooperative communications when the medium access method as shown in Fig 3.1.1.4(b) is applied. The RTS and CTS frames are used to reserve the medium for cooperative transmissions; however, terminal A is hidden to terminal S and terminal D. Transmissions from terminal A and terminal R are collision.

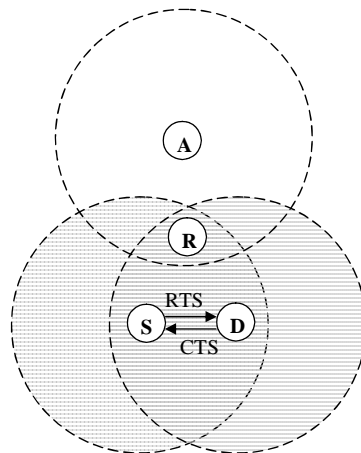

Figure 3.1.1.5: An example of hidden terminal problems in cooperative communications.

MAC Cooperative Protocols Characteristics

Cooperative setup in the MAC layer can be classified into two categories based on relay selection methods; i.e., ***distributed*** and ***centralized relay selecting methods***.

Furthermore, relay selections may be done either on a per frame basis (it is a ***connectionless*** mode) or per flow basis (it is a ***connection-oriented*** mode). For connectionless, the relay selections of cooperative setup in the MAC layer are done in each single data frame transmission. In contrast, for connection-oriented transmission methods, the relay selections of cooperative setup in the MAC layer will be done once and the chosen relay terminal will be used in multiple data frames, or until the end of data transmissions, or until route recovery processes are required.

3.1.2. Distributed Relay Selections

In distributed relay selection methods, the selections are done by each Potential Relay Terminal (PRT). The decisions are done based only on all local relay selecting information collected by the relay itself. As proposed in [ShZW09], a distributed cooperative MAC for multihop wireless network (DCM), each PRT proposes itself to work as a selected relay. The proposition is done based on its two-hop transmission rates

(source-to-relay and relay-to-destination) *calculated from RTS/CTS frames* of the handshake between source-destination pair. This cooperative setup is suitable for connectionless transmission method because the relay selection is done for each data frame transmission.

DCM Cooperative Setup Method

For cooperative setup, every terminal of the DCM method is assumed to work in the cooperative mode transmission all the time; therefore, *cooperative mode activation signaling* is not required. Each terminal internally activates itself to work in the cooperative mode transmission. The cooperative mode activation makes each PRT terminal *to acquire* its two-hop transmission rates, which will be used in the relay selecting method. The two-hop transmission rates can be acquired by listening RTS/CTS frames respectively sent from a source terminal and a destination terminal. As shown in Fig.3.1.2.1, if any PRTs have their two-hop transmission rate higher than source-destination single-hop rate, they send out a Helper Indicator (HI) frame. The HI frame is used *to notify* the willingness and the existence of relays to the source and destination terminals. If there is no HI frame, the source terminal starts to send its data in non-cooperative transmission mode. Thus, HI frame is used to switch the transmission mode between cooperative and non-cooperative modes meaning that DCM can work with adaptive cooperative transmissions.

After sending an HI frame, each PRT sends out a Ready-To-Help (RTH) frame after a backoff time. The backoff time is calculated based on its two-hop transmission. The best relay ends the backoff process earliest. As shown in Fig.3.1.2.1, the good PRT ends its backoff process earlier than the bad PRT; thus, it sends out a RTH frame first. When bad PRTs receive the RTH frame sent from the best PRT, they remain quiet with a Network Allocation Vector (NAV) value. The NAV value maintains a prediction of future traffic on the medium based on duration information that is announced in RTS/CTS frames. However, note that if the bad PRTs are hidden from the best PRT, they compete with the best PRT on transmitting the RTH frame, which causes collision problems.

When the destination terminal receives the RTH frame, it broadcasts a Clear-To-Receive (CTR) frame for three purposes. First, the CTR frame is used to confirm the chosen relay terminal that it has to work on data relaying. Second, it is used to notify all PRTs to stop their contention, and third, to notify the source terminal to start to send its data frame.

DCM Resource Allocations

For resource allocations, as shown in Fig.3.1.2.1, the DCM method uses the CTR frame to notify the chosen relay terminal that it has to defer with SIFS after receiving a data frame sent from the source terminal, then it has to work on data relaying.

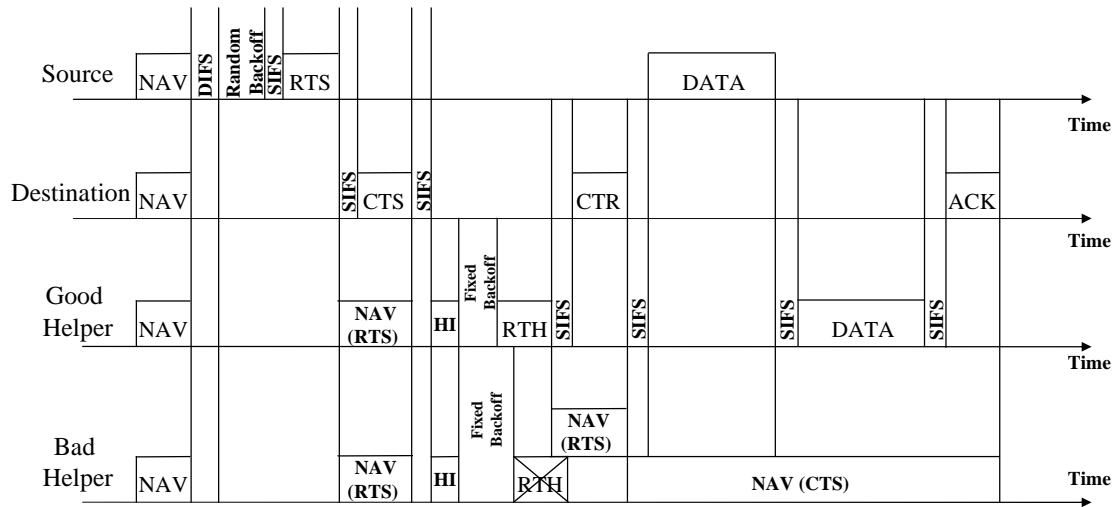

Figure 3.1.2.1: Frame schedule of the IEEE802.11 DFC-based cooperative MAC.

Hidden Terminal Problems in Distributed Relay Selecting Methods

The DCM method also faces with hidden terminal problems. If the good PRT (R_1) and the bad PRT (R_2) are located as shown in Fig 3.1.2.2, they are hidden to each other. Therefore, see Fig.3.1.2.1, the RTH frames from the good PRT and the bad PRT are collision at the destination terminal.

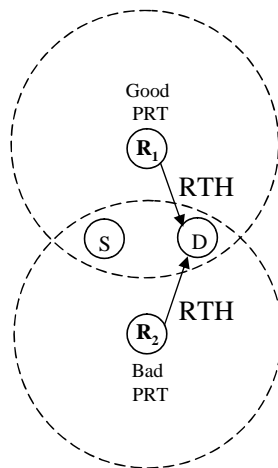

Figure 3.1.2.2: Hidden terminal problems between PRTs in DCM method.

Advantages/Disadvantages of Distributed Relay Selecting Methods

To participate in cooperative transmissions, each PRT makes its own decision based only on all local relay selecting information collected by the relay itself; thus, accumulating methods, which is used to collect relay selecting information of other PRTs are not

required. Thus, distributed relay selections are not complex and can fast interact with its relay selection process.

However, since the relay selecting information of each relay terminal is not compared, the optimal relay selection may not be provided. In addition, if PRTs are hidden to each other, more than one PRT proposes itself to work on data relaying; thus, collision is occurred. Therefore, in these contexts, centralized relay selecting methods have been proposed.

3.1.3. Centralized Relay Selections

In centralized relay selecting methods, relay selecting information of all PRTs are compared. Thus, the optimal relay selection can be provided and problems of hidden terminal among PRTs are also alleviated. However, in contrast to distributed relay selecting methods, these selecting methods require accumulating methods to collect relay selecting information of all PRTs. Thus, it gains complexity and delay to the networks.

Centralized selecting methods can be applied in both of infrastructure and non-infrastructure networks. In networks with infrastructure, the relay selecting information is collected at base stations for cellular networks and at access points for WLAN networks. For non-infrastructure networks such as ad hoc networks, the relay selecting information is collected at a source terminal or a destination terminal.

A Cooperative MAC for Wireless LANs (CoopMAC) [LTNK07] is a major example of centralized relay selecting method implemented in an ad hoc network.

This protocol is centralized since the decision is made based on all information indicated in the “CoopTable” at a source terminal. The CoopTable is introduced in each mobile terminal in order to collect data rates of the transmissions from itself to the i^{th} PRT (R_{SR_i}) and from the i^{th} PRT to the destination terminal (R_{RiD}). Based on IEEE 802.11 standard, the creation and updating of the CoopTable can be done by passively listening to all ongoing transmissions. The R_{SR_i} is acquired by the measurement at terminal S when it passively listening to ongoing transmissions of the i^{th} PRT. The R_{RiD} is added into the physical-level header of the frames sent from terminal D to terminal S.

At the source terminal, if one of transmission rates through high rate two-hop transmissions via any PRTs is higher than that of the source-destination single-hop rate, a cooperative transmission mode is turned on. A relay terminal having highest transmission rate will be chosen. If there is not any PRTs having its two-hop transmission rate higher than that of the source-destination single-hop rate, CoopMAC remains its transmission mode in non-cooperative transmissions. Thus, CoopMAC can be implemented in adaptive cooperative transmissions.

CoopMAC Cooperative Setup Method

Since every terminal of CoopMAC method is assumed to work in the cooperative mode transmission all the time; cooperative mode activation signaling is not required. Each terminal internally activates itself to work in the cooperative mode transmission. The cooperative mode activation allows each terminal to passively listen to all ongoing transmissions and create the “CoopTable”. For cooperative mode notification, the chosen relay is notified by *a modified RTS frame* (called CoopRTS) sent from the source terminal as shown in Fig.3.1.3.1. In CoopRTS, three new fields are appended to the RTS frame, which are the MAC address of the chosen relay, R_{SR} , and R_{RD} .

When terminal R receives the modified RTS frame, it checks if the R_{SR} and R_{RD} can be sustained. Then, a Helper Ready to Send (HTS) packet *derived from CTS frame* is unicastly sent from terminal R to terminal S. When terminal D hears the HTS frame, it unicastly send a CTS frame back to terminal S to reserve the channel for a two-hop transmission via the chosen relay terminal.

Illustrations of the message flow, the exchange of control packets, and the exchange of data/ACK packet for CoopMAC are shown in Fig.3.1.3.1, Fig.3.1.3.2 and Fig.3.1.3.3, respectively.

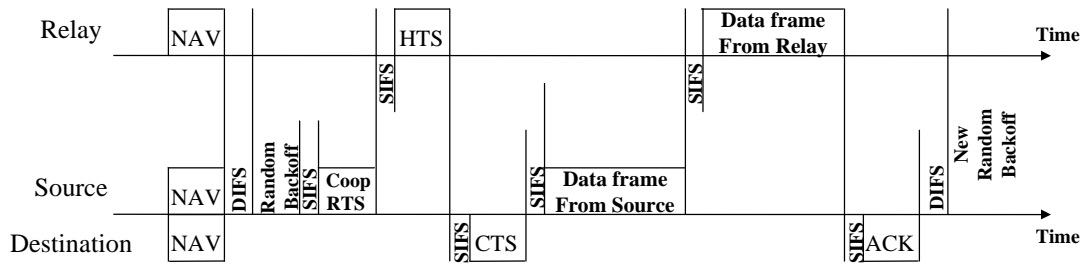

Figure 3.1.3.1: Message flow in CoopMAC.

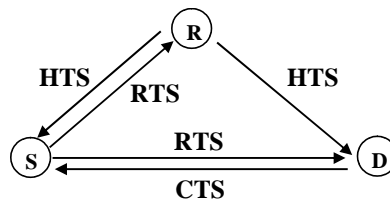

Figure 3.1.3.2: The exchange of control packets for CoopMAC.

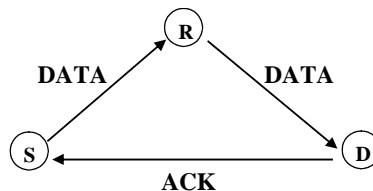

Figure 3.1.3.3: The exchange of data and ACK packets for CoopMAC.

CoopMAC Resource Allocations

For resource allocation, as shown in Fig.3.1.3.1, the CoopMAC method uses the CTS frame to notify the chosen relay terminal and the source terminal to switch its transmission mode from a direct transmission mode (S to D) to a multi-hop transmission mode (S to R to D). Thus, in cooperative transmission mode, the chosen relay terminal will defer itself with SIFS value after receiving a data frame sent from the source terminal, then it has to work on data relaying.

Hidden Terminal Problems in Centralized Relay Selecting Methods

In contrast to distributed relay selections, cooperative setup in the MAC layer with centralized relay selections can alleviate hidden terminal problems among PRTs. However, it still has some problems on hidden terminals as shown in Fig.3.1.3.4.

In the handshaking method of CoopMAC, CoopRTS, HTS, and CTR frames are used to respectively reserve the medium for terminal S, R, and D. The use of an additional control frame (i.e., HTS) causes the handshaking method of CoopMAC takes longer time than the optional access method of the IEEE 802.11. Thus, terminal E takes longer time to know that terminal D would like to use the medium than when it works with the legacy handshaking (see Fig.3.1.3.4). Therefore, the probability that terminal E interferes the handshaking method of CoopMAC the handshaking is higher than that of the legacy handshaking.

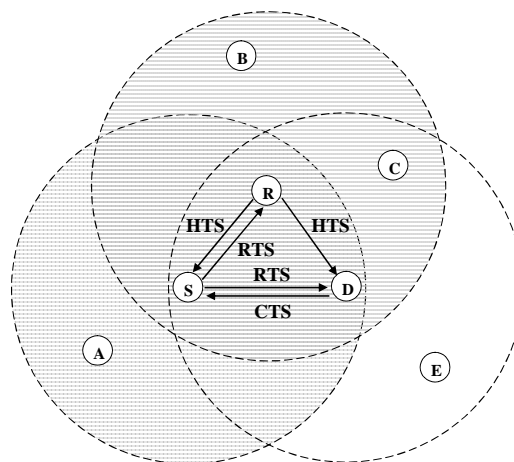

Figure 3.1.3.4: Hidden terminal problems in CoopMAC method.

Advantages/Disadvantages of centralized relay selecting methods

In centralized relay selections, accumulating methods used for collecting relay selecting information of other PRTs are required. Thus, it is more complicated and generates more delay compared with distributed relay selecting methods. Nevertheless, since the relay

selecting information of every relay terminal is compared, optimal relay selections are provided.

For hidden terminal problems, centralized relay selections still have some problems on hidden terminal (as shown in Fig.3.1.3.4 for example). However, unlike distributed relay selections, the hidden terminal problems among PRTs in centralized relay selections are alleviated.

3.1.4. Conclusion of cooperative setup in the MAC layer

The presented examples of cooperative setup in the MAC layer address the issues of cooperative mode activations, cooperative mode notifications, relay selections, and resource allocation. They support different cooperative transmission methods (connectionless or connection-oriented) and different relay selections (distributed or centralized). The activations/notifications between cooperative participating terminals and the resource allocations are done based on the IEEE 802.11 MAC standard with some modifications. The proposed examples illustrate also various methods to measure the channel conditions in order to choose the relays.

Connectionless Support

The advantage of cooperative setup in MAC layer when it works with connectionless transmission methods is that it can tackle with channel variations faster than connection-oriented transmission methods since its relay selections are processed in each single data frame. However, to select a new relay terminal in every single data frame causes delay and overhead to the networks. Furthermore, in power conservative point of view, [ZoRo03a] and [ZoRo03b] recognize that transmitting, receiving, and listening to an idle radio channel require comparable amount of power. The only way to save substantial energy is to allow mobile terminal to be powered off or to be switched in a sleep mode. In these contexts, connection-oriented transmission methods are interesting.

Supportable Only the Optional Access Method

The examples of cooperative setup in the MAC show that RTS and CTR frames in the MAC layer have been used and modified for cooperative mode activations, cooperative mode notification, or relay selections (in both of distributed and centralized relay selections); thus, cooperative setup in the MAC layer can be implemented only in the networks using the optional access method of IEEE 802.11 protocol. They cannot work with the basic access method. To transmit data in the optional access method of is costly in term of resource consumption when the size of data frame is small compared with the size of RTS/CTS frames. Moreover, the optional access method consumes more power than the basic one. Therefore, there are some researches propose cooperative setup methods in the network layer. Instead of being processed in the MAC layer, cooperative setup processes are done in the network layer.

3.2. COOPERATIVE SETUP IN THE NETWORK LAYER

In wireless networks, generally, only one best route is chosen for forwarding data from a source terminal to a destination terminal. There are many routing protocols, which have been developed and are used in wireless networks such as Dynamic Source Routing (DSR) [JoMa96], Destination-Sequenced Distance-Vector Routing (DSDV) [PeBh94], and Ad hoc On-Demand Distance Vector (AODV) [PeRD03]. These protocols perform well but cannot directly be implemented to cooperative communications since more than one route are required to send data from a source to a destination (or from a previous terminal to a next-hop terminal); therefore, cooperative routing protocols have been developed.

Cooperative setup in the network layer is usually called “*cooperative routing protocols*” since these protocols mainly incorporate cooperative transmission into route selections. The objectives are to take advantages of cooperative communications in term of energy saving when several terminals cooperate to forward the information to the next-hop terminal along a route to the destination. However, details of cooperative mode activations, cooperative mode notifications and resource allocations have generally been neglected, [GuDC09], [KAMZ07], [MMMZ09], [SMTE07], and [YaLH05], for examples.

3.2.1. Cooperative Setup in the Network Layer Mainly Concerns with Relay Selections

[MMMZ09] is an example of cooperative routing protocol, which has been proposed to take advantages of energy saving provided by cooperative transmissions. Similar to [AkEr08], [IbHL07], and [YaLH05] for instance, the relay selection is done based on total power consumption, which is used to forward data from a source terminal to a destination terminal. The link costs of each link have been considered. The link costs represent minimum power requirement for data transmissions in each link, which allows the receivers to be able to decode the data correctly.

More clearly, an example of how cooperative transmissions provide advantages of energy saving to the network is shown in Fig.3.2.1.1. The link costs of each link are as shown in Fig.3.2.1.1a. Terminal 1 has its data to send to the terminal 4. For non-cooperative direct transmissions, from terminal 1 to terminal 4, the minimum power required for non-cooperative direct transmissions (P_{Direct}) is 42, as shown in Fig.3.2.1.1b. For non-cooperative multi-hop transmissions, the data are sent from terminal 1 to terminal 2 and to terminals 4. The minimum power required for non-cooperative multi-hop transmissions ($P_{\text{Multi-hop}}$) is 40 acquired by 10 from terminal 1 to terminal 2 ($P_{\text{Multi-hop1}}$) and 30 from terminal 2 to terminal 4 ($P_{\text{Multi-hop2}}$), as shown in Fig.3.2.1.1c.

For cooperative transmissions (see Fig.3.2.1.1d), terminal 2 is chosen to work as a relay terminal. To allow terminal 2 to be able to decode data sent from terminal 1 correctly, it

requires minimum power for data transmissions ($P_{\text{Cooperative1}}$) equals to 10. To make terminal 4 to be able to decode data correctly based on power constraint, $(P_{\text{Cooperative1}})/42 + (P_{\text{Cooperative2}})/30 = 1$, and thus it requires $(P_{\text{Cooperative2}}) \approx 22.86$. Therefore, the overall power consumption for cooperative transmissions ($P_{\text{Cooperative}}$) is then $(P_{\text{Cooperative1}}) + (P_{\text{Cooperative2}}) = 32.86$, which is less than the overall power consumption for non-cooperative direct transmissions and the overall power consumption for non-cooperative multi-hop transmissions.

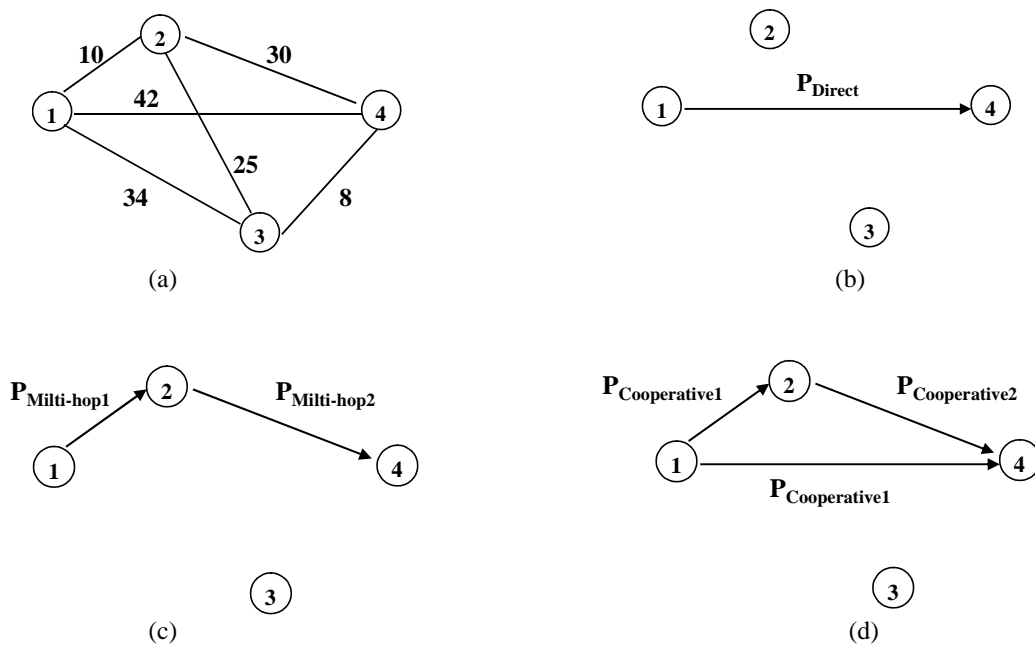

Figure 3.2.1.1: An illustrative network with link costs in term of minimum power requirement for data transmissions.

Other link metrics used for relay selection in the network layer have also been introduced in [CZZY07] and [SMTE07], the relay selecting method has done based on the remaining energy of the relay terminal, the Channel State Information (CSI) of the cooperative path from source to relay and to destination terminals, and the probability of the detection error in a given route.

Examples of cooperative setup in the network layer show that relay selecting methods have been extensively introduced; however, in contrast to cooperative setup in the MAC layer, details of cooperative mode activations, cooperative mode notifications, and resource allocation methods have not been widely concerned. There are very few researches that propose cooperative setup in the network layer with details of these issues.

3.2.2. Cooperative Setup in the Network Layer with All Details of Cooperative Setup

In contrast to other general cooperative setup in the network layer, an ad hoc cooperative routing algorithm based on optimal channel selection (ACR) [ChZZ06] with all details of cooperative setup has been proposed. ACR method is an example of cooperative setup in the network layer that details of cooperative mode activations, cooperative mode notifications, and resource allocation methods have been considered. The routing algorithm of ACR is a cross-layer method; channel state information (CSI) from the physical layer and multicast technology at the MAC layer are considered. ACR has been developed based on a Destination-Sequenced Distance-Vector (DSDV) [PeBh94] which is a table-driven routing protocol, which requires every terminal to maintain a routing table pointing to the next hop of the arbitrary destination terminals. Routing update is done by periodical *routing update packet* sent by the neighbour terminals.

ACR modifies the DSDV routing protocol to be able to support cooperative transmissions by implementing an additional table in each mobile terminal called a *neighbour terminal table*. The neighbour terminal table records the addresses of all neighbour terminals and the addresses of the next-hop of these neighbour terminals (also called 2-hop neighbour terminals).

For example, as shown in Fig.3.2.2.1, terminal 1 has five neighbour terminals (2, 3, 4, 5, and 6) while terminal 2 has three neighbour terminals (1, 3, and 4). For routing update, terminal 1 sends a routing update packet, as shown in Fig.3.2.2.2, to its neighbour terminals. When terminal 2, for example, receives the routing update packet, it updates its routing table and also its neighbour terminal table as shown in Fig.3.2.2.3 and 3.2.2.4, respectively.

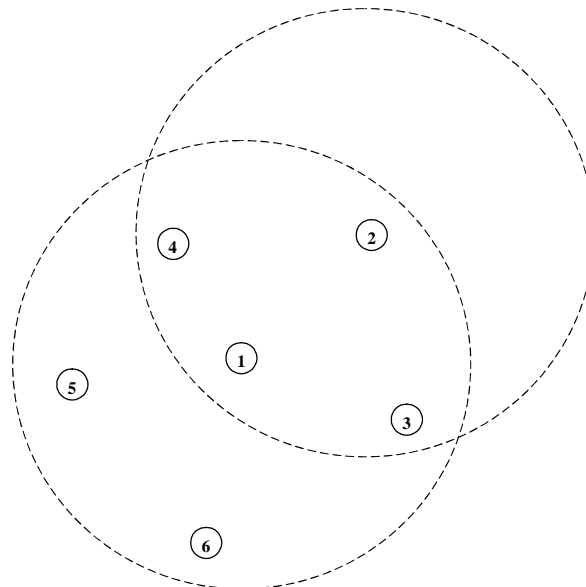

Figure 3.2.2.1: An illustrative network with 6 terminals.

1	Seq Num	Metric	...	2, 3, 4, 5, 6
---	---------	--------	-----	---------------

Figure 3.2.2.2: Routing update packet of the terminal 1.

Destination	Metric	Next Hop	Seq Num
1	0		24
3	0		19
4	0		36
5	1	1	25
6	1	1	31

Figure 3.2.2.3: An example of the routing table at terminal 2.

Terminal id	SNR (received power)	Neighbour terminal id
1	3, 4, 5, 6
.....

Figure 3.2.2.4: An example of neighbour terminal table at terminal 2.

From the routing table and neighbour terminal table as respectively shown in Fig.3.2.2.3 and Fig.3.2.2.4, terminal 2 knows that terminal 3 and 4 locate between terminal 1 and 2, and they are called PRTs which are able to work as relay terminals. Thus, for the relay selection, one of the PRTs is chosen based on the SNR value in the neighbour terminal table.

ACR Cooperative setup

For cooperative setup, every terminal of ACR method is assumed to work in the cooperative mode transmission all the time; thus, it internally activates itself to work in the cooperative mode transmission. The cooperative activation allows each terminal to generate routing update packets and its neighbour terminal table. In the cooperative mode notification process, the chosen relay terminal is notified by data frames in the MAC layer. The source terminal unicastly sends its cooperative data frames to the chosen relay terminal.

ACR Resource Allocations

The data transmissions of ACR are separated into three phases. In the first phase, a data frame is sent from a source terminal S to a destination terminal D. In the second phase, the same data frame (called a cooperative data frame) is sent from S to the chosen relay terminal R indicated by the address of the relay terminal in the header of the data frame; then, R forwards the cooperative data frame to D in the third phase, as shown in Fig.3.2.2.5.

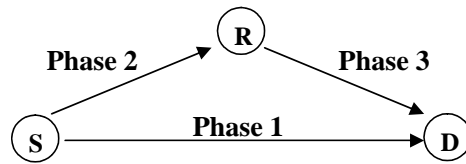

Figure 3.2.2.5: The resource allocation of ACR.

Advantages/Disadvantages of ACR Cooperative Setup

Delay Increment

As shown in Fig.3.2.2.5, in contrast to other cooperative transmission modes that at least two time slots are required to send one data frame from a source terminal and a relay terminal, ACR requires at least three time slots to send one data frame in its cooperative transmission mode. This requirement causes delay to the ACR systems.

Connection-oriented transmissions

Similar to the traditional routing protocols, relay selecting methods of cooperative setup in the network layer are not processed frame-by-frame. The chosen cooperative routing terminals will be used for multi-frame transmissions, or it will be used until the end of data transmissions or until route recovery processes are required; thus, they cannot fast tackle with channel variations.

IEEE 802.11 Basic & Optional Access Modes Supportable

The major advantage of the ACR method is that its cooperative setup is done in the network layer and its resource allocation method does not use or modify RTS/CTS frames. Therefore, ACR can be implemented with both of the basic and the optional access modes of the IEEE802.11 MAC protocol.

Adaptive Cooperative Transmission Support

The ACR can support adaptive cooperative transmissions since the source terminal can decide whether the cooperative transmission mode should be turned on or not. If the cooperative transmission mode can provide higher transmission rate than the non-cooperative one, S sends its data frame to D and sends its cooperative data frame to R, otherwise S transmits in the non-cooperative mode by only sending its data frame to D.

3.2.3. Conclusion of cooperative setup in the network layer

Cooperative setup in the network layer is usually called “***cooperative routing protocols***” since the main objective of cooperative setup in the network layer is to design relay selecting methods.

Relay Selecting Methods are Only Concerned

Although the relay selecting methods have been extensively introduced in cooperative setup in the network layer, in contrast to cooperative setup in the MAC layer, details of

how terminals interact to each others (such as the cooperative mode activation and cooperative mode notification methods), and resource allocation methods have not been widely concerned.

IEEE 802.11 Basic & Optional Access Modes Supportable

Since the relay selection methods have been introduced in the network layer, and cooperative mode activations/notifications can be also done in the network layer, RTS/CTR frames are not used or modified. Therefore, the major advantage of cooperative setup in the network layer is that it is flexible to interact with the MAC layer since it can be implemented with both of basic and optional access modes of the IEEE802.11 protocol.

Connection-oriented Transmissions

Similar to the traditional routing protocols, relay selecting methods of cooperative setup in the network layer are not processed frame-by-frame as proposed in cooperative setup in the MAC layer; therefore, they cannot fast tackle with channel variations compared to relay selecting methods of cooperative setup in the MAC layer. The chosen cooperative routing terminals will be used for multi-frame transmissions, or it will be used until the end of data transmissions or until route recovery processes are required.

Energy conservations

Because the relay selection method is done once and the result is used for multi-frame transmissions or until the end of data transmissions, these relay selecting methods provide advantage in term of energy saving. Only the chosen relay terminal is in an activate mode while other potential relay terminals can be powered off or can be switched to an idle mode.

3.3. COMPARISONS OF COOPERATIVE SETUP IN THE MAC LAYER AND THE NETWORK LAYER

Cooperative setup functions

Every issue on inter-layer interaction between cooperative transmissions in the physical layer to the upper layers, cooperative mode activations, cooperative mode notifications, relay selections, and resource allocations have been considered in cooperative setup in the MAC layer while cooperative setup in the network layer generally consider only on relay selection methods.

Interoperability of the IEEE802.11 MAC standard

Based on IEEE 802.11 MAC standard, cooperative setup in the MAC layer uses and modifies RTS/CTS frames; thus, it can only be implemented in the optional access mode of the standard. The use of RTS/CTS frame is costly when the size of data frame is small. In contrast, cooperative setup in the network layer does not use or modify RTS/CTS

frames in the MAC layer; therefore, it can be implemented in both of the basic access mode and the optional access mode of the standard.

Transmission method supports

Cooperative setup in the MAC layer supports both of connectionless and connection-oriented transmission methods while cooperative setup in the network layer is suitable for connection-oriented transmissions.

3.4. CONCLUSION

Different cooperative setup have been designed in the MAC layer and the network layer in order to answer issues on how physical-layer cooperative transmissions can be integrated with higher layers of the protocol stack and how layers of the protocol stack interact to each others. These requirements make cooperative setup to be complicate.

Cooperative setup designs concern with many tasks such as relay selections, cooperative mode activations, cooperative mode notifications, and resource allocations. In addition, each cooperative setup has to be designed to support each specific type of cooperative transmission methods in the physical layer. The details of cooperative transmissions such as they are fixed or adaptive cooperative transmissions, or their transmission modes are connectionless or connection-oriented methods must be considered.

Therefore, in order to compare or develop existing protocols and to design future cooperative communication protocols, we proposed a model called **“Cooperative Network Model”** to facilitate these purposes. The details of the Coop Network Model will be described in Chapter 4 of this thesis.

Chapter 4

COOPERATIVE NETWORK MODEL

(A PROPOSITION ON NETWORK MODEL)

Contents

- 4.1. Proposed Model (Cooperative Network Model)
 - 4.2. Data Plane
 - 4.3. Control Plane
 - 4.3.1. CF1: Cooperative mode activations
 - 4.3.2. CF2: Cooperative information acquisitions
 - 4.3.3. CF3: Relay selection algorithms
 - 4.3.4. CF4: Cooperative mode notifications
 - 4.4. Applying the Proposed Cooperative Network Model to Existing Protocols
 - 4.4.1. Modelling the ACR protocol: Cooperative setup in the network layer
 - 4.4.2. Modelling the DCM protocol: Distributed cooperative setup in the MAC layer
 - 4.4.3. Modelling the CoopMAC protocol: Centralized cooperative setup in the MAC layer
 - 4.5. Conclusion
-
-

The design of cooperative communications involves several layers of the Open Systems Interconnection (OSI) model. Transmission and multiplexing techniques of cooperative communications are addressed at the physical layer as proposed in [LaTW04], [JKFK07], [SEA03a], [SEA03b], and [JHHN04] whereas the cooperative setup (such as cooperative mode activations/notifications among cooperative participating terminals, relay selections, and resource allocations) is done at the layers above (mainly at the Medium Access Control (MAC) layer and Network layer) as proposed in [AzAA05], [LTNK07], and [BISW07].

However, the comparison of the existing approaches is difficult since there are no common criteria adapted in this domain and, to our knowledge, a common framework of description does not exist yet. Therefore, we propose an original framework of a

cooperative network at the system level called “**Cooperative Network Model**” [EPRP08].

The purpose is to analyse the cooperation process in its entirety by integrating both the physical notion that have been presented in the first and second chapters and the cooperation achievement with the protocol notions presented in the chapter 3. The interest is to understand what the cooperation is and how it can be achieved.

The main difficulty of the modeling is to represent interaction in the protocol level of the cooperative setup with the data treatment level. We adopted an approach that has been developed for telephonic networks, the plane modeling; a plane is devoted to the cooperative setup while another one to the data. In the plane modelling, the model does not reflect the protocol layering; thus, we can generalize the cooperation process and obtain an analysis that is available for many solutions.

Chapter Organization

At the first part of this chapter, the proposed model is explained. Functional processes, abbreviations, and interactions between the two planes will be described. At the second part, a validation of the proposed framework is given by modeling the existing cooperative routing and cooperative MAC protocols that have been presented in the previous chapter.

4.1. PROPOSED MODEL (COOPERATIVE NETWORK MODEL)

Inspired from models of the International Telecommunication Union (ITU) normative organization, our cooperative network model is based on two planes: a data plane and a control plane (as shown in Fig.4.1.1). The data plane responds for cooperative transmissions while the control plane is in charge of the cooperative transmission setup.

The instantiation of the model depends on cooperative methods and terminal types: the source, relay, and destination terminals are terminals with cooperative functionalities. The illustrations of model usages are presented in section 4.4 through examples of existing cooperative protocols. Notations of each model element in each plane are detailed as follows.

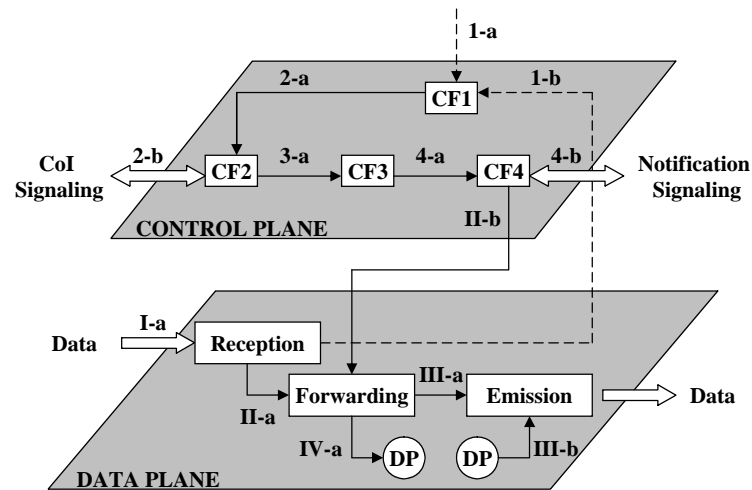

Figure 4.1.1: Cooperative Network Model.

Notation:

Arrow Numbering: An input arrow is labeled with a number associated to its input block. Because the model does not represent temporal dependencies between the planes, numbering of the control plane is done Arab numbering while Roman numbering is used for the data plane; i.e. the input arrows of the forwarding square block in the data plane are labeled II-a and II-b, the input of the CF1 square block are 1-a and 1-b, for instance.

Double arrows: If any cooperative functions of a terminal supporting the proposed model have to exchange (i.e., receive or send) data with other terminals, it is symbolized by the double arrows.

Circle DP (Data Processing): The data exchanges between terminals are under the responsibility of a protocol stack. Since cooperation may be achieved at different protocol levels, as seen in the previous chapters, the protocol stack is not detailed in the model. The *circle DP* is used to represent an access point to the communication protocols and their Data Processing in the protocol stack. In addition, since the cooperative model

does not reflect the protocol layering, for convenience, we are going to use generic term “frame” to describe the model without suppose that it is related to any specific protocol levels.

Based on Fig.4.1.1, data frames are received by the reception block in the data plane through I-a. It is an input from an external terminal. Data frames may or may not concern with the cooperation. Those that concern the cooperation will be interpreted by some data processing to be further treated by the control plane. This link between data plane and control plane is protocol dependant; it is not explicitly shown on the figure. We consider that there is an access between the control and the data planes that is achieved by the communication protocol stack through DP circles.

Square block: Inside a terminal, there are different functional blocks that are represented by *square blocks* in the figure. Depending upon the model instantiation, some functional block may be empty. For example, considering a centralized relay selection algorithm done by the source terminal, the functional blocks associated to the relay selection process are empty at the destination terminal and at the relay terminal while they are full at the source one.

Simple arrows: They show the interactions between blocks. The inputs/outputs of a block are treated data and activations. Activations are shown by *dashed arrow* while data are *full arrow*. To alleviate troublesome figures, only the activations connected to the cooperative mode activation process are presented. Else, it is supposed that when a block receives data, it is automatically activated.

4.2. DATA PLANE

The data plane of the model is composed of three blocks corresponding to data receptions, data emissions, and data forwarding. In cooperative transmissions, data sent from a source terminal and a relay terminal may or may not be combined at a destination terminal. In addition, the combinations can be also done either in the signal level or bit level depending upon the cooperation schemes. Therefore, note that the data combinations can be either under the responsibility of the reception block or the forwarding block. Our analysis does not detail in this point.

The Reception Block

When data are received through I-a, the reception block is able to compute the Cyclic Redundant Check (CRC) and measure the signal level of the received data. Then, if the received data are erroneous for example, the reception block sends an activation to trigger the cooperation in the control plane through 1-b. The activation will be treated by a given block (CF1).

The received data are also passed to the forwarding block through II-a. The two outputs of the reception block are not exclusives. An erroneous frame reception can trigger the cooperation and also generate an error message that will be later treated by a protocol.

The Forwarding Block

The forwarding block stores and decides on how to treat the data frames (acquired from II-a). It acts as an on-off switch that is able to switch its transmission mode between cooperative transmission mode and non-cooperative transmission mode according to the activation sent by the control plane through II-b.

The forwarding block is essential for every terminal in cooperative transmission. For example, the forwarding block of the source terminal informs its emission block (through III-a) to reserve more medium for data transmission done by itself and by a relay terminal or it has to communicate with the DP block (through IV-a) to add additional cooperative information in the data frame. At a relay terminal, the forwarding block controls its data relaying process whether it has to work with cooperative transmissions or not. For a destination terminal, after the forwarding block receives a data frame from the reception block, it treats the received data differently in non-cooperative transmissions and cooperative ones. The received data sent by a source terminal may be sent directly to the DP block or it must wait for the relay data sent from a relay terminal.

There are two ways to notify the forwarding block. The first one is to inform by a per data basis, the second one is to inform by a per flow basis. The first method considers that cooperation is decided for each data frame transmission. It is like a connectionless transmission. The second method decides on cooperation for a set of data packets. The relay selection result is memorized for a period of time (the connection time, for example). It is like a connection-oriented transmission.

The interest of using a given transmission mode depends on the channel time variability and the overhead control. If the channel does not change significantly over a time period greater than the connection time, the connection-oriented transmission mode is usable. It would generate less control overhead than the connection less mode. Otherwise, the connectionless transmission mode would be recommended.

- ***Connectionless method***

For connectionless methods, cooperative protocols are usually implemented in the MAC layer. Basically, for each data frame, the protocol selects a relay terminal and allocates time for data relaying. The chosen relay terminal forwards the overheard data after some frame exchanges. Many propositions have been made in this context. They are mainly based on the IEEE 802.11 standard and on the exchange of RTS/CTS frames with some additional extensions, [AzAA05], [BISW07], [LTNK07], and [ZhCa06] for examples.

- ***Connection- oriented method***

A switching table is consulted on data arrival. The table contains the identity of the received data and the forwarding state (ON, OFF). The identity value is provided by

the transmission system or by the MAC protocol through the MAC address. The relay table can be filled by routing protocols, MAC protocols, or cross-layer mechanisms.

In cooperative transmissions, if any frame modifications are not required (Relay receives data and then forward them to the destination), the received data frames are directly forwarded to the emission block through III-a. If frame modifications are required, the received data are sent to the DP through IV-a (for de-encapsulations and re-encapsulations, for example). Then, the data from the DP are sent to the emission block through III-b in order to be transmitted to the destination terminal.

If the terminal that received the data frame is the destination of the data frame, the received frames are sent through IV-a to be de-encapsulated and processed by the DP.

Data Processing (DP)

The DP is an access to the communication protocol stack for data processing. The destination terminal passes the received data to its DP to be de-encapsulated and processed. If the data concern with any cooperative functions in the control plane, the data will be passed to those cooperative functions through double arrows in the control plane. The DP also responds for data and control information encapsulations before they are emitted by the emission block. The encapsulated frames are sent to the emission block through III-b.

Emission Block

The emission block is in charge of the data and control information transmitting. The inputs of the emission block are sent from the forwarding block through III-a and the DP through III-b.

Data plane illustration

Example of data transmission in cooperative communications is shown in Fig.4.2.1. The DP of the source terminal S generates a data frame and transmits it to an emission block of itself. Then, the data frame is emitted to a destination terminal D and also the relay terminal R. When R works in cooperative transmission mode, it responds on data relaying. Thus, at terminal R, the data frame is sent from the reception block to the forwarding block. If the data frame needs not to be modified, the data frame is directly forwarded to the emission block. Then, the emission block of R help terminal S to re-emit the data to terminal D. Finally, terminal D passes these received data to its data processing.

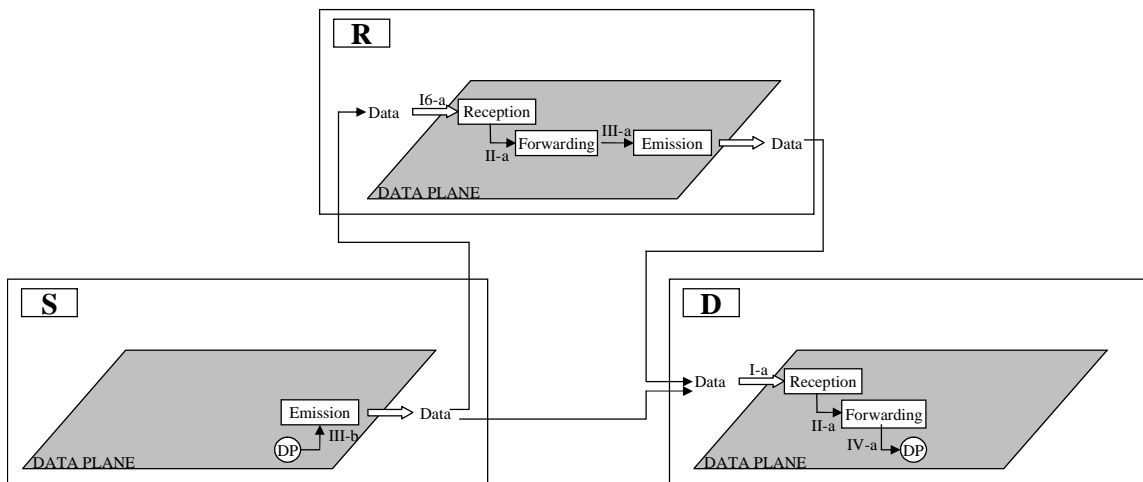

Figure 4.2.1: A data transmission method in cooperative communications.

4.3. CONTROL PLANE

The objective of the control plane is to setup a cooperative environment for the networks. When systems require to work in cooperative mode, the control plane of every cooperative participating terminal (i.e., a source terminal, potential relay terminals, and a destination terminal) has to communicate together in order to choose a relay (or a set of relays) terminal and activate the data forwarding block in its data plane.

This modeling approach is similar to the one used to represent the functions related to the services in Public Switched Telephone Networks (PSTNs). In PSTNs, the control plane is in charge of the voice path set up, while the data plane is in charge of the voice transport.

We put forward four functions in the control plane, i.e.

- CF1: Cooperative mode activation
- CF2: Cooperative information acquisition
- CF3: Relay selection algorithm
- CF4: Cooperative mode notification

4.3.1. CF1: Cooperative Mode Activation

If we consider that terminals are always in a cooperative mode, they are activated by default, else the cooperative mode has to be activated. The cooperation mode activation is similar to a terminal activation in the sense that the terminal is online but it does not mean that the terminal transmits or receives. So, even if the cooperative mode is activated it is not yet instantiated. Instantiation would be done by some signaling exchanges between the terminals. Since the cooperation mode is on, signaling messages are treated

by a given terminal else they will be deleted. The interest of this function is to simply enable or disable the cooperation processes.

As shown in the figure of cooperative network model, there are two inputs that can activate cooperative setup processes. These two inputs correspond to two types of activations; i.e., an external and an internal one.

First, when cooperation is internally activated, the cooperative setup process is initiated by any other layer's processes of the protocol stack. The activation is done through (1-a) as shown in Fig.4.3.1.1. The triggering process may be a configuration process that manages the power consumption, or a transport layer process that manages the packet error rate. However, precisely consider the activation done by the transport layer, since transport protocol is only concerned the end to end terminals of a given communication, the cooperative setup at intermediate terminals have to be activated by other ways (e.g., other protocols or default activations). Even if the source and the destination terminals are link adjacent, the transport protocol can only activate the cooperation at the source terminal and the destination terminal, not at the relay terminal. Thus, the relay terminal must be activated by other ways or by default.

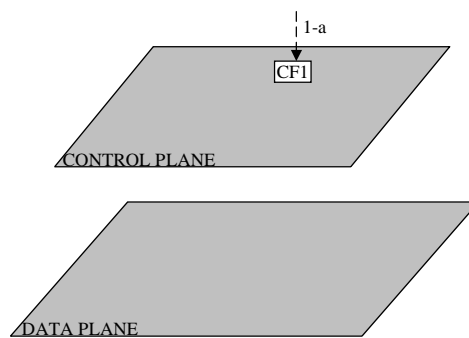

Figure 4.3.1.1: Internal cooperative mode activations.

Second, when cooperation is externally configured, the cooperative setup process is activated when needed based on the received data at the reception block in the data plane. If any errors or cooperative activating frames have been detected by the reception block, the CF1 block in the control plane is activated through 1-b, as shown in Fig.4.3.1.2. Once the cooperation mode is activated, other cooperative functions in cooperative setup processes are started to select a relay terminal, or a pre-determined of a relay terminal (or a set of relay terminals) is parameterized in the activating frames ([LTNK07] and [JKFK07]).

Furthermore, cooperative mode activations can be done in hybrid ways. Both of the external and internal cooperative mode activations are concerned. For example, the

cooperative setup processes will be activated if terminals have enough remaining power and errors in the received data are detected.

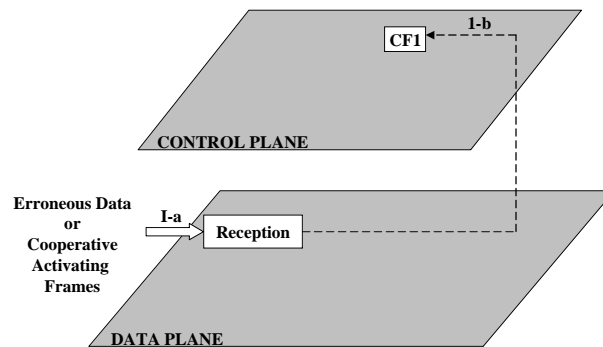

Figure 4.3.1.2: External cooperative mode activations.

4.3.2. CF2: Cooperative Information Acquisition

The cooperative information acquisition block (CF2) is under the control of the cooperative mode activation one. The CF1 triggers and sends Cooperative Information (CoI) to the CF2 through 2-a. CoI is information that will be used in relay selecting methods. Therefore, the responsibility of the CoI acquisition function is to exchange and collect all CoI among cooperative participating terminals as shown in Fig.4.3.2.1.

If the CoI is already available at the terminal (i.e. remaining power, queue length or the transmission error rate), CF2 transmits it to CF3; otherwise, CF2 has to obtain the CoI by a signaling protocol, named CoI signaling. The CoI signaling is done through 2-b.

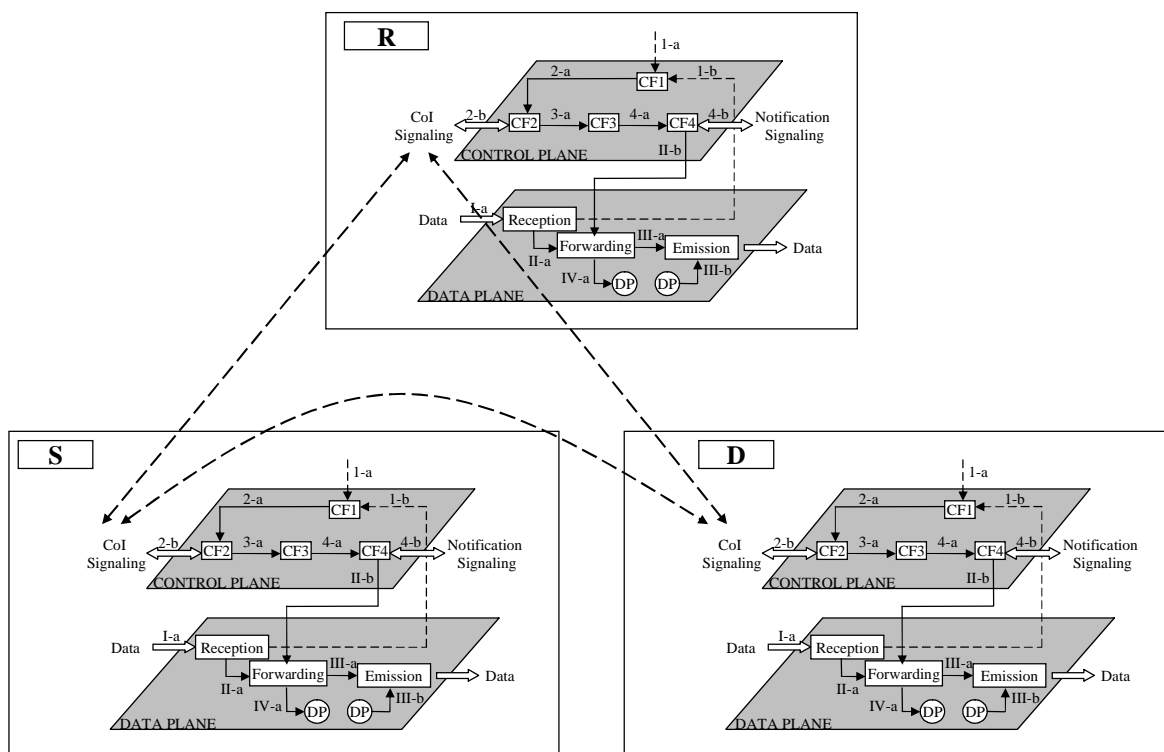

Figure 4.3.2.1: Cooperation information signaling among cooperative participating terminals.

Cooperation Information (CoI)

CoI may include parameters related to the quality of the radio channel (sometimes referred to a channel state information: CSI) or administrative information (e.g., remaining power or queue length). Examples of CoI are the estimations of the Rayleigh gain (g_{ij}) between terminal i and terminal j as used in [BISW07] or the estimation of the Signal-to-Noise ratios (SNR_{ij}) between both terminals as found in [ChYW07]. CoI can be available at the terminal or it can be sent from other cooperative participating terminals by being added in RTS/CTS frames as proposed in [ChYW07] and [LTNK07].

Cooperation Information signaling

The signaling solutions are characterized by their type and their level. They can be separated into two categories; out-band and in-band signaling. When out-band signaling is implemented, a specific protocol is designed for the control plane. It induces extra resources consumption. In contrast, when in-band signaling is considered, the data protocol is used to transmit signaling information. It may be a standardised protocol with minor modifications, or a new protocol. The signaling may be achieved at the physical level, PLCP (Physical Layer Convergence Protocol) level, MAC level, routing level, or at cross-layer level.

Signaling Protocol: Control plane and Data plane Interactions

To transmit and receive the cooperative information, the control plane has to interact with the data plane. Fig.4.3.2.2a illustrates an example of the interaction between the control plane and the data plane when a CoI signaling is initialized at a source terminal. The CF1 triggers and may send local CoI to the CF2 through 2-a. Then, the CF2 block communicates with the DP block in the data plane to generate a control frame to send the CoI to other cooperative participating terminals. The control frame is sent through the emission block through III-b.

Fig.4.3.2.2b shows CoI receptions at a relay terminal and a destination terminal. The CF2 blocks of terminal R and D collect local CoI sent from CF1 through 2-a and inter CoI extracted from the CoI frame, which are received from the reception block in their data planes.

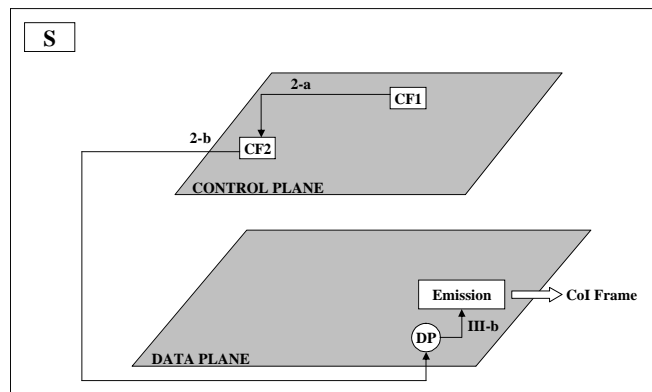

(a) Initialization of the CoI signaling at a source terminal.

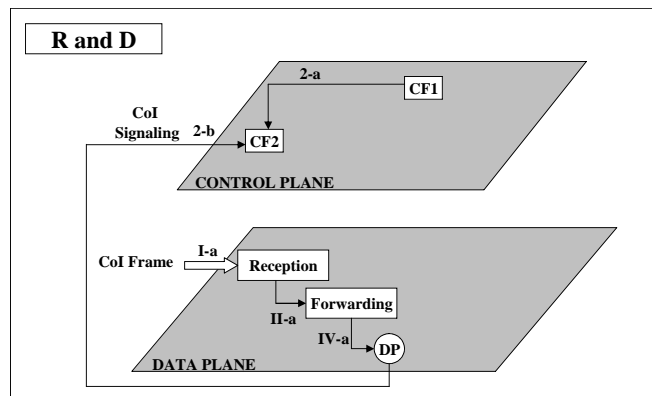

(b) CoI reception at a relay terminal and a destination terminal.

Figure 4.3.2.2: Example of Cooperative Information (CoI) signaling.

4.3.3. CF3: Relay Selection Algorithm

The collected CoI is sent from a CF2 to a CF3 block through 3-a in order to be processed to choose a relay (or a set of relays) terminal as shown in Fig.4.3.3.1. Classical selection criteria are best source-relay and relay-destination channels, and maximum achievable data rates. The result of CF3 (4-a) is constituted by the selected relay terminals based on information obtained by CoI signaling (2b then 3a) or by administrative configuration (i.e., local CoI acquired from 1-a, 2-a, and 3a).

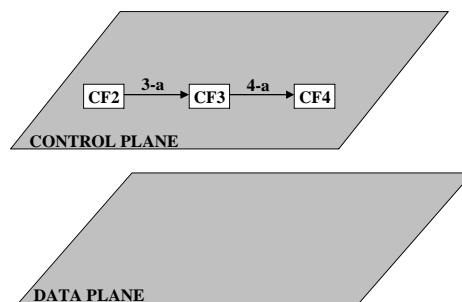

Figure 4.3.3.1: Relay selections.

We assume that the terminal in charge of this process is also in charge of the relay notification function in the CF4 block. The relay selection can be done by the source, the destination, or the relay terminals.

An optimum selection process occurs when CoI of every potential relay terminal (PRT) is provided at the CF3 block of the terminal responding for relay selection. The respective merits of every PRT are compared and allow the CF3 block to determine the best relay (or a set of best relays). Otherwise, for distributed relay selections, the CF3 block of each PRT can only get the CoI of itself as proposed in [BISW07] and [ChYW07], the PRT simply decides whether it should work in cooperative transmission mode or not.

At the end of the relay selection process, the CF3 block delivers the result to the CF4 block (the cooperative mode notification). In addition, CF3 may also compute some additional parameters such as the allocated transmitting power, or the transmission rate for each cooperative participating terminal as proposed in [AzAA05], [LTNK07], and [ZhCa06].

4.3.4. CF4: Cooperative Mode Notification

Once the relay selection has been processed, all cooperative participating terminals (i.e., the source terminal, the destination terminal, the selected relay terminal or the set of selected relay terminals, and all other PRTs) should be notified. In particular, the selected relay terminal has to know the result of the selection in order to achieve the forwarding in the data plane.

In the proposed cooperative network model, two types of the notifications of the CF4 block are noted. There are an internal activation (II-b) and an external one (4-b). The internal activation refers to plane interactions inside a terminal while the external one concerns the interaction between peer entities inside the control plane of different terminals. In the first case, a PRT obtains its transmission mode (i.e., cooperative transmission mode or non-cooperative transmissions mode) through the internal notification (II-b) between the control plane and the data plane. In the second case, the terminal being in charge of the relay selection is also in charge of the cooperative mode notification to all cooperative participating terminals. The notification signaling will be received through 4-b and then it will be used for plane interactions inside the terminal as shown in Fig.4.3.4.1.

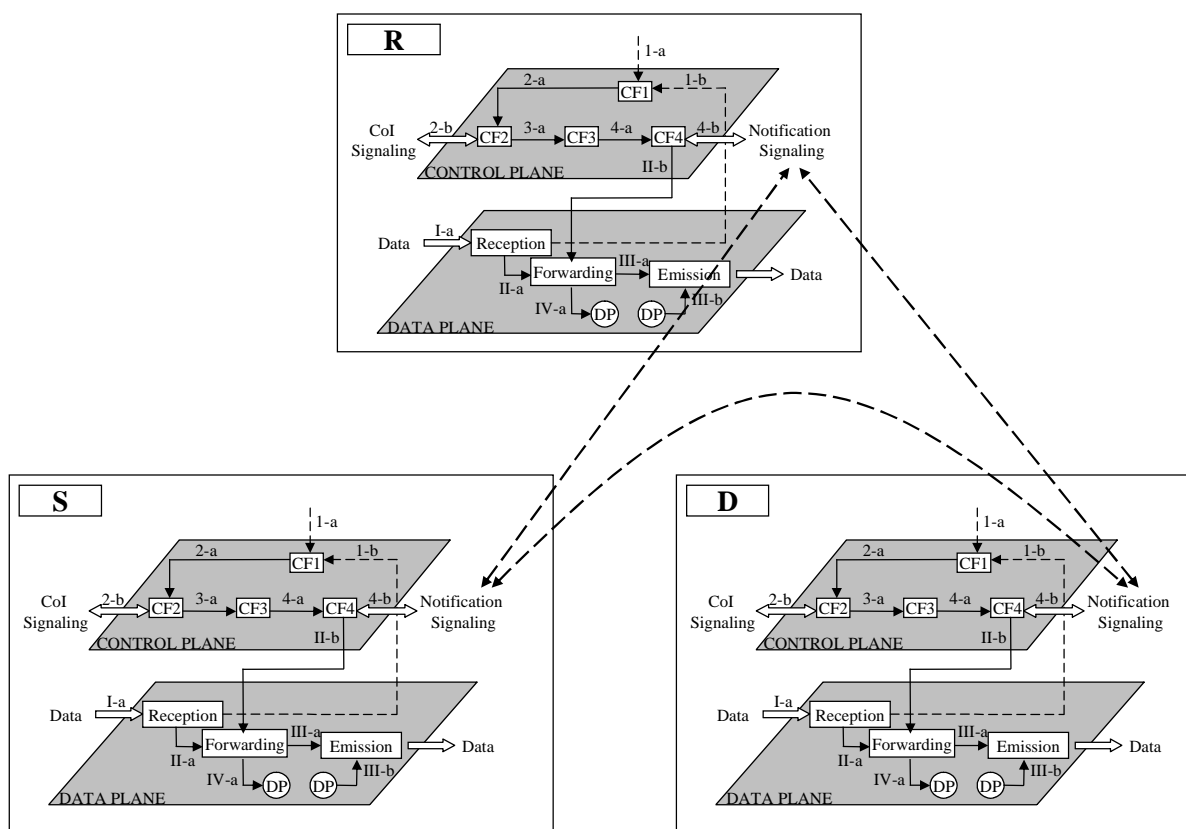

Figure 4.3.4.1: Cooperative mode notification signaling among cooperative participating terminals.

As previously stated concerning with the CoI signaling, there are also several types of cooperative mode notification signalizations, i.e. out-band and in-band signaling that require interaction between data and control planes.

More precisely, assume that the terminal D responds to cooperative mode notification. Its CF4 block will interact with the DP block in order to generate a notification frame to send out to notify every cooperative participating terminal as shown in Fig.4.3.4.2.

When the terminal R and terminal S receive the notification frame sent by terminal D, the notification is respectively sent from the reception block to the forwarding block and to the DP block in the data plane of terminal R and terminal S. Then, the CF4 blocks in the control plane are notified (see Fig.4.3.4.3). The cooperative setup is finished when every participating terminal is notified that it has to participate on cooperative communication.

After cooperative setup, every terminal is ready to work on cooperative transmissions. When the CF4 block of terminal R is notified, terminal R knows that it has to work as a relay terminal. The forwarding block of terminal R is internally notified through II-b that it has to communicate with the DP block or/and the emission block to work on data relaying in the cooperative transmission mode.

When the CF4 block of terminal S is notified, terminal S knows that it has to send data in cooperative transmission mode and terminal R will work as a relay terminal. The forwarding block of terminal S is internally notified through II-b that it has to communicate with the DP block or/and the emission block to modify its data frames and/or to configure its transmission parameters to be able to work in its cooperative transmission mode.

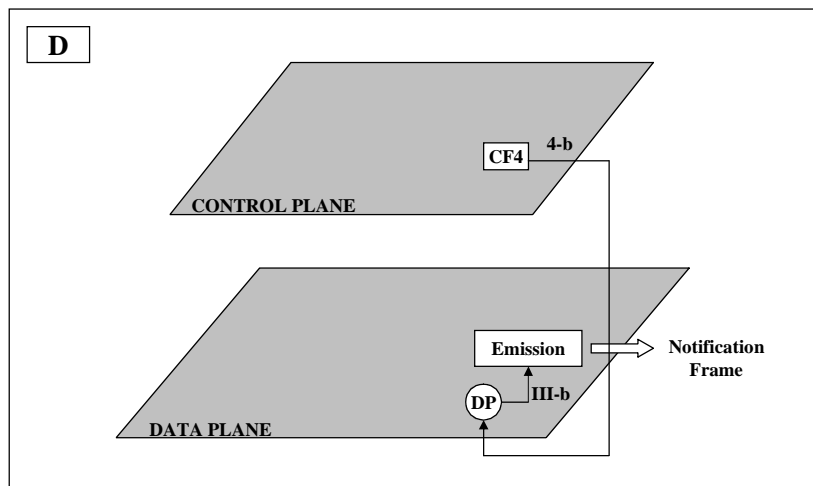

Figure 4.3.4.2: Example of cooperative mode notification initiated by the destination terminal D.

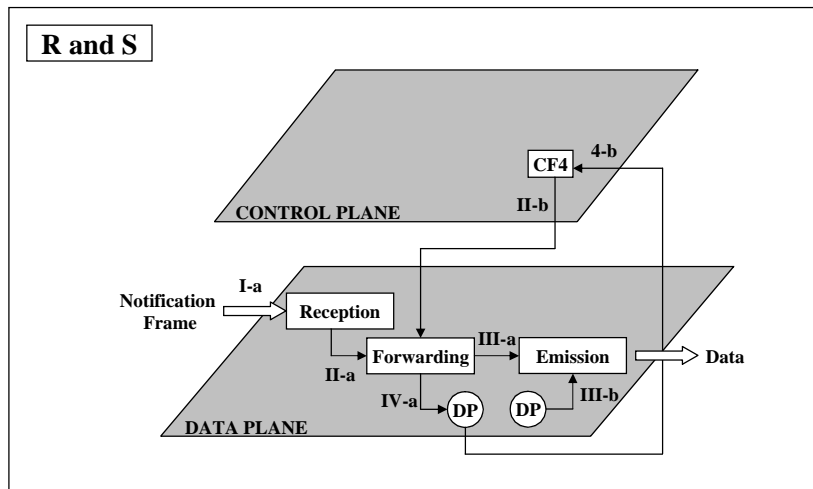

Figure 4.3.4.3: Example of cooperative mode notification when the relay terminal R and terminal S are notified.

4.4. APPLYING THE PROPOSED COOPERATIVE NETWORK MODEL TO EXISTING PROTOCOLS

In this section, three different cooperation protocols implemented at the network layer and the IEEE 802.11 MAC layer standard will be explained through the proposed model. These cooperation protocols are representatives of various types of cooperation setup protocols since they are designed at different levels and different schemes of relay selections. The chosen cooperation protocols are as follows.

- A cooperative setup protocol in the network layer, referred to An Ad Hoc Cooperative Routing Algorithm Based on Optimal Channel Selection (**ACR**) [ChZZ06].
- A distributed cooperation protocol in the MAC layer, referred to a Distributed Cooperative MAC for Multihop Wireless Networks (**DCM**) [ShZW09].
- A centralized cooperation protocol in the MAC layer, referred to a Cooperative MAC protocol for Wireless Local Area Networks (**CoopMAC**) [LTNK07]

These cooperation protocols have been chosen in order to show the capacity of our proposed model that it can describe different scenarios of cooperation.

In this part, we are going to show that applying the model analysis is useful for a better understanding of the cooperation achievements. In addition, some questions are posed by the analyses, which are not presented in the references, helping us to precise the design of the proposed protocols.

4.4.1. Modelling the ACR Protocol: Cooperative Setup in the Network Layer

ACR is an example of cooperative setup in the network layer. It creates an additional table called *a neighbour terminal table* in order to store next-next-hop addresses. The routing table and the neighbour terminal table are periodically updated by *a routing update packet* sent by neighbour terminals

The neighbour terminal table allows the source terminal to know which terminals are PRTs; i.e. terminals that are located between the source terminal and the destination terminal. For the relay selection, one of the PRTs is chosen based on the SNR value in the neighbour terminal table.

After relay selection, S transmits data in cooperative transmission mode. The data transmissions of ACR are separated into three phases. The data in ACR are sent two times from a source terminal. In the first phase, a data frame is sent to the destination terminal. In the second phase, a copied of the data frame (called a cooperative data frame) is sent to the chosen relay terminal indicated by the address of the relay terminal in the header of the data frame; then, the relay terminal forwards the cooperative data frame to the destination terminal in the third phase.

To describe the protocol by our model, we shall clearly describe the achievement of the protocol onto the three terminals involved in the cooperative communication (i.e., the source terminal S, the potential relay terminal R, and the destination terminal D).

Network model at a PRT R

For ACR cooperative mode activation, the CF1 block of every PRT is assumed to be always activated by its upper layers (1-a); thus, the CF1 block of PRT is empty. The activation is set as default in order to allow every terminal with cooperative functionality to periodically transmit routing update packets to its neighbour terminals.

These routing update packets are used as cooperative information (CoI) for the relay selection, which is done at terminal S. Thus, for CoI acquisitions, the CF2 block of each PRT periodically communicates to its data plane to generate and transmit route updating packets to its neighbour terminals (especially to the source terminal).

Since the relay selection is done at terminal S, the CF3 block of PRT is empty. After the relay selection, terminal S transmits a data frame to terminal D and a copy of the data frame (called cooperative data frame) to terminal R. The cooperative data frame is indicated by the MAC address of the relay terminal in the header of the data frame. Thus, similar to *non-cooperative multi-hop transmission*, the reception block of terminal R passes the received cooperative data frame to the forwarding block and the DP block. The DP block processes the data and sends to the emission block. Then, the emission block forwards the cooperative data frame to terminal D.

The interactions between the data plane and the control plane, and the sequencing of the different block processes in the two planes of ACR method are illustrated in Fig.4.4.1.1. A rounded rectangle blocks represents a data or a control frame while a cooperative function block in the control plane or the data plane of the cooperative network model is represented by a rectangular block.

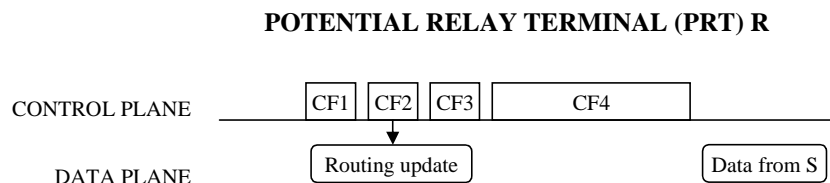

Figure 4.4.1.1: Data plane and control plane interactions of the ACR protocol at a potential relay terminal R.

▪ *Limitation in ACR design*

After mapping the ACR method to the proposed cooperative network model, we found that the CF4 block of terminal R in the ACR method has never been interacted (see Fig 4.4.1.1). The CF4 block concerns with cooperative mode notifications.

A responsibility of the CF4 block in the control plane is to notify the forwarding block in the data plane for the cooperation. If the forwarding block has never been notified on cooperation, it means that cooperative data frame forwarding at terminal R is always done in non-cooperative transmission mode. More precisely, when terminal R receives a cooperative data frame, it is kept in the queue buffer of terminal R to wait to be forwarded. The queuing process is usually a First-In First-Out (FIFO) method meaning that if terminal R has its data to send and these data are waiting in the queue buffer, the received cooperative data frame will be forwarded after all data in the queue buffer terminal R have been sent.

In fact, in cooperative transmission mode, terminal R has to forward every cooperative data frame immediately after the reception in order to allow terminal D to be able to combine the cooperative data frame sent by terminal R with the original data frame sent from terminal S. Therefore, the data plane of terminal R must be notified of the cooperation in order to treat cooperative data frames differently to simple data frames.

For the solution, we propose that a given bit should be indicated in the data frame header called “*a cooperation bit*”. When the cooperation bit is detected in the header of data frames, the CF4 block of terminal R is notified that it has to work in cooperative transmission mode. The CF4 block will internally activate its forwarding block in the data plane to forward the received data frame in cooperative transmission mode.

The forwarding block immediately prepares a relay cooperative data frame for the emission block through III-a or III-b. Then, the emission block sends the cooperative data frame with an appropriate medium allocation. The medium allocation may be assigned by

the source terminal so that terminal R knows when it has to access to the medium. However, details of medium allocations in the reference are not given.

Fig.4.4.1.2 represents the interactions between the data plane and the control plane, and the sequencing of the different block processes in the two planes of ACR method when a cooperation bit is considered.

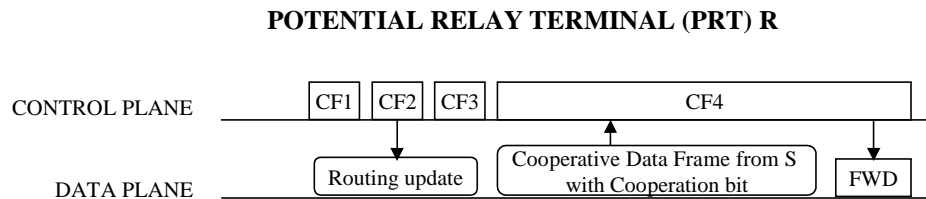

Figure 4.4.1.2: Data plane and control plane interactions of the ACR protocol with cooperation bit at a potential relay terminal R.

Network model at the source terminal S

Similar to terminal R, assuming that the cooperative mode is always enabled by upper layers (1-a); thus, the CF1 block of terminal S is also empty. The received routing update information is sent to CF2 block and is collected into the neighbour terminal table as shown in Fig.4.4.1.3. The CoI information is forwarded to the CF3 block of terminal S and is used for relay selections.

The CF3 of terminal S chooses one of the PRTs in its neighbour terminal table to work as a relay terminal (i.e., terminal R). Then, the CF4 block of terminal S send a data frame to terminal D and a cooperative data frame to terminal R. As discussed above, we suppose that a cooperation bit is added into the data frame and the cooperative data frame in order to notify terminal D and terminal R on the cooperation. The data frame and the cooperative data frame are prepared by the DP and are sent to the emission block of the data plane.

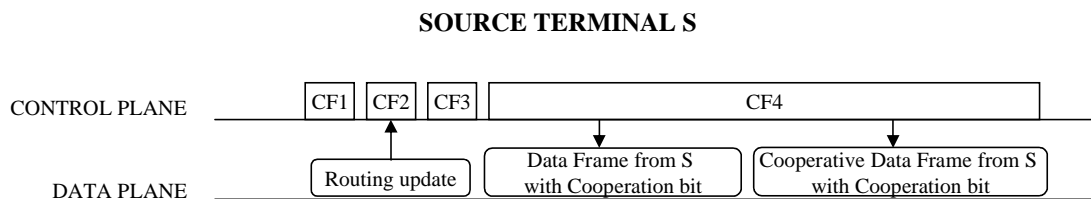

Figure 4.4.1.3: Data plane and control plane interactions of the ACR protocol with cooperation bit at the source terminal S.

Network model at the destination terminal D

Similar to terminal R and terminal S, the CF1 block of terminal D is empty since the cooperative mode of terminal D is also assumed to be activated by default. The CF2 block of terminal D periodically sends the route updating packets to its neighbour

terminals (especially to the source terminal) as shown in Fig.4.4.1.4. The CF3 block is empty because the relay selection is done at terminal S.

As discussed above, we suppose that a cooperation bit is added into the data frame and the cooperative data frame in order to notify the CF4 block of terminal D on the cooperation. The cooperation bits inform terminal D that it has to wait and combine the data frame with the cooperative data frame.

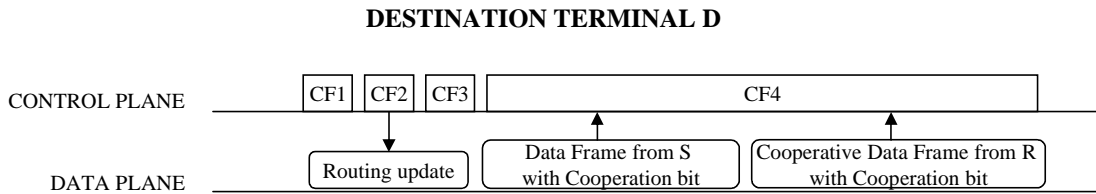

Figure 4.4.1.4: Data plane and control plane interactions of the ACR protocol with cooperation bit at the destination terminal D.

The interaction among cooperative models of all cooperative participating terminals in the ACR protocol after adding the cooperation bit is shown in Fig.4.4.1.5.

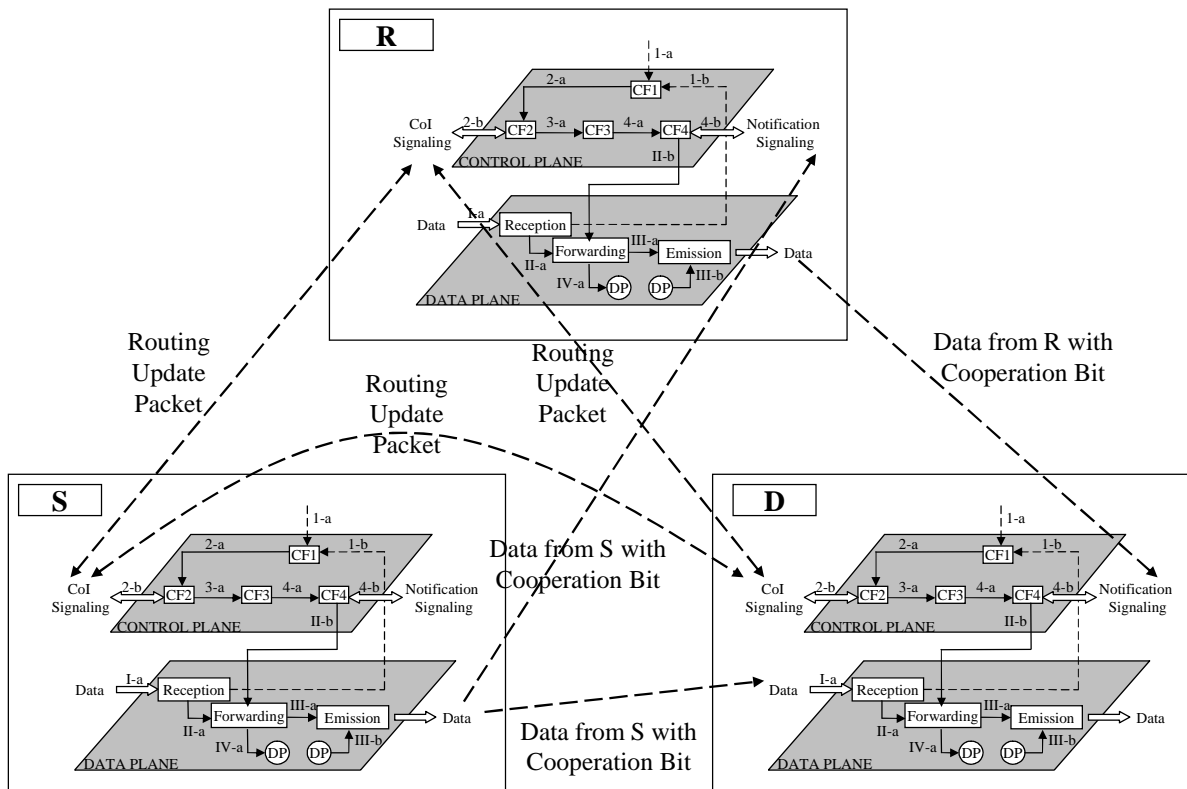

Figure 4.4.1.5: The interaction among cooperative models of all cooperative participating terminals in the ACR protocol.

Conclusion

The ACR protocol, which is a cooperative setup protocol in the network layer, can be clearly illustrated and explained by the proposed cooperative network model. In addition, the proposed cooperative network model helps us to find a limitation in the ACR design. We found that the CF4 block of every terminal in the ACR protocol neither interacts with the CF4 blocks of other terminals nor its data plane. Thus, it may have a problem on cooperative mode notification among terminals and between the planes as we have explained above.

4.4.2. Modelling the DCM Protocol: Distributed Cooperative Setup in the MAC Layer

DCM is a distributed cooperative setup method. The relay selection is done by the PRTs themselves. The PRTs in DCM protocol estimate the instantaneous wireless channel gain between the source terminal S and the i^{th} PRT (g_{SRi}) from RTS frames and the instantaneous wireless channel gain between the i^{th} PRT and the destination D (g_{RiD}) from CTS frames. The forward and backward channels between the i^{th} PRT and terminal D are assumed to be identical due to the reciprocity theorem that Ri to D and D to Ri channels use the same frequency band. Therefore, g_{RiD} is equal to g_{DRi} .

In addition, the PRTs also keep the instantaneous wireless channel gain between the source terminal S and the destination D (g_{SD}) that is indicated in CTS frames

The channel gains are converted to transmission rates. If any PRTs have their two-hop transmission rate (S to Ri to D) higher than the single-hop transmission rate (S to D), the relay selection process will be done. To choose the best relay, each PRT calculates its timer (T_i) based on g_{SRi} and g_{RiD} . The most appropriate relay has its timer reduced to zero first. To notify all participating terminals, the best relay broadcasts a Helper Indicator (HI) out. The interaction among cooperative models of all cooperative participating terminals is shown in Fig.4.4.2.1.

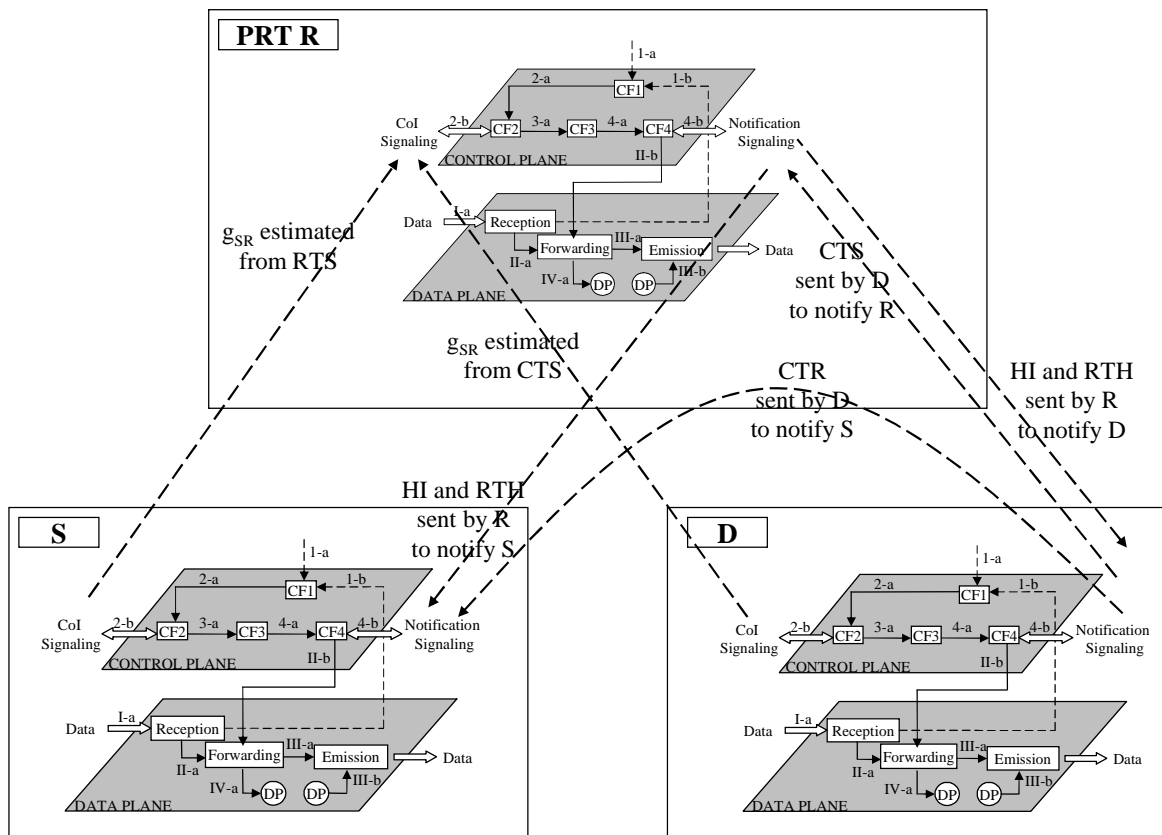

Figure 4.4.2.1: The interaction among cooperative models of all cooperative participating terminals in the DCM protocol.

Network model at a PRT R

In the DCM approach, the cooperative mode is assumed to be always activated. Thus, the CF1 block of R is enabled through 1-a by the upper layers. The activation is set as default in order to allow every PRT with cooperative functionality to estimate g_{SR} and g_{RD} from the classical RTS/CTS procedure, and to collect the estimation of g_{SD} that is indicated in the CTS frame.

For CoI acquisition, terminal R has to collect CoI in terms of g_{SR} , g_{RD} , and g_{SD} to be used in the relay selection process. More precisely, when a RTS or CTS frame is received by the reception block in the data plane of terminal R, it is passed through the forwarding block and is processed by the DP. The DP estimates the g_{SR} or g_{RD} , collects g_{SD} (if any), and communicates with the CF2 block in the control plane in order to allow the CF2 block to collect these CoI as shown in Fig.4.4.2.2.

The interactions between the data plane and the control plane, and the sequencing of the different block processes in the two planes of DCM method are illustrated in Fig.4.4.2.2.

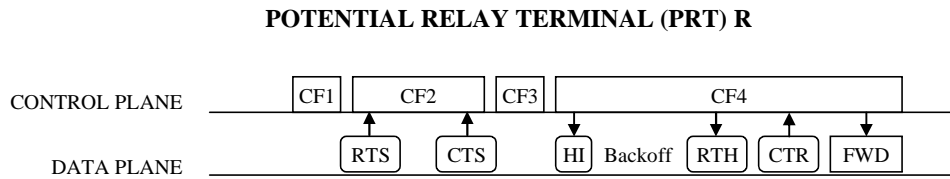

Figure 4.4.2.2: Data plane and control plane interactions of the DCM protocol at a PRT R.

After the CoI acquisition, g_{SRi} , g_{RiD} , and g_{SD} are sent to the CF3 block to be used for relay selections. The channel gains are converted to transmission rates. If any potential relay terminals have their two-hop transmission rate is higher than the single-hop transmission rate, the CF3 block informs the relay notification block (CF4), and a HI frame is sent out from the CF4 block. The HI frame is used to aware the willingness and the existence of relays to the source and destination terminals. If there is no HI frame, the source terminal starts to send its data in non-cooperative transmission mode.

After sending an HI frame, each PRT delay itself for a backoff time. The backoff time is inversely proportional to the end-to-end channel quality calculated based on both parameters g_{SR} and g_{RD} . The best relay ends the backoff process earliest. Then, a Ready-To-Help (RTH) frame is sent from the relay notification block CF4 of the relay terminal. When terminal D receives the RTH frame, it broadcasts a Clear-to-Receive (CTR) frame to notify other PRTs to stop their contention and to inform the source terminal to send its data.

In addition, the CTR frame allows the CF4 in the control plane of the best PRT to internally notify its data plane. This control signal activates the forwarding block in the data plane of the best relay terminal. Therefore, the best PRT is ready to work on data relaying in the cooperative transmission mode.

Network model at the source terminal S

Similar to terminal R, the cooperative setup process of DCM is assumed to be always activated. The distributed relay selection method of DCM allows each potential relay terminal (PRT) to work on CoI acquisition and relay selection independently; thus, the CF2 and CF3 blocks of terminal S are empty.

The reception of the HI frame notifies the CF4 block of S through 1-b (see Fig.4.4.2.3) that the cooperative transmission is enabled. If there is no HI frame (detected by a timer expiration managed by CF4), the source terminal starts to send its data in non-cooperative transmission mode. HI frame is used to switch the transmission mode between cooperative and non-cooperative transmission modes. In addition, the CF4 block of terminal S waits for the RTH frame sent from the best PRT and the CTR frame from the

destination terminal D to confirm that terminal R and terminal D are ready to work in cooperative transmission mode.

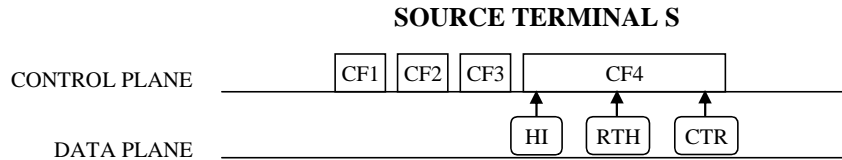

Figure 4.4.2.3: Data plane and control plane interactions of the DCM protocol at the source terminal S.

Network model at the destination terminal D

Since the cooperative mode of DCM is assumed to be always activated, similar to terminal S and R, the CF1 block of D is triggered by the upper layers through 1-a and is empty.

For CoI acquisition, the CF2 block interacts with the DP in the data plane to create an in-band signaling (a CTS frame with the estimated g_{SD}). The g_{SD} will be used in the relay selection process at every PRT. The CF3 blocks of terminal D is empty because the relay selection is processed at each PRT.

The reception of the HI frame notifies the CF4 block of D through 1-b (see Fig.4.4.2.4) that terminal D has to work in cooperative transmission mode. If there is no HI frame, terminal D works in non-cooperative transmission mode. The CF4 block of D is also re-notified by the RTH frame sent from the best PRT. After receiving the RTH frame, terminal D broadcasts a CTR frame to confirm the best PRT that it is chosen, to notify other PRTs to stop contention (PRTs may be hidden to each other), to re-confirm terminal S that terminal R will work as a relay terminal, and to inform terminal S to send its data.

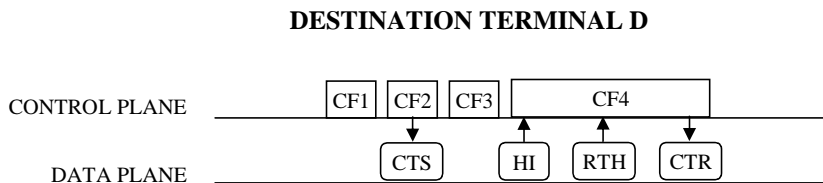

Figure 4.4.2.4: Data plane and control plane interactions of the DCM protocol at the destination terminal D.

Conclusion

The proposed cooperative network model shows that the DCM protocol, which is a distributed cooperative setup protocol in the MAC layer, can be clearly illustrated and

described by the proposed model. Details and interactions of every block in both of the control plane and the data plane have been considered.

4.4.3. Modelling the CoopMAC Protocol: Centralized Cooperative Setup in the MAC Layer

In contrast to the distributed DCM approach for which the relay selection is done by each PRT, the relay selection of the centralized CoopMAC method is managed by the source terminal S. The cooperative mode is connection oriented.

In CoopMAC, every terminal with cooperative functionality is assumed to be always activated since it has to create and update its Helper Table. The table is used to gathering information about the achievable data rates from itself to each PRT and data rates from each PRT to its next-hop terminal. These achievable data rates are used as the CoI that will be used by the relay selection method in the cooperative setup process.

For example, the source terminal maintains and updates its Helper Table with the achievable data rates R_{SR_i} (i.e., the data rate from terminal S to the i^{th} PRT) and R_{R_iD} (i.e., the data rate from the i^{th} PRT to terminal D). The R_{SR_i} is acquired by the measurement at terminal S when it passively listening to ongoing transmissions of the i^{th} PRT. The R_{R_iD} is a data rate that is used to transmit data from the i^{th} PRT to terminal D. The R_{R_iD} is indicated into the physical-level header of the data frames of this transmission pair. Thus, when terminal S overhears these data frames, it can get the R_{R_iD} form the physical-level header of these data frames. This table is used for relay selection. The Illustration of control packet exchanges of CoopMAC is shown in Fig.4.4.3.1.

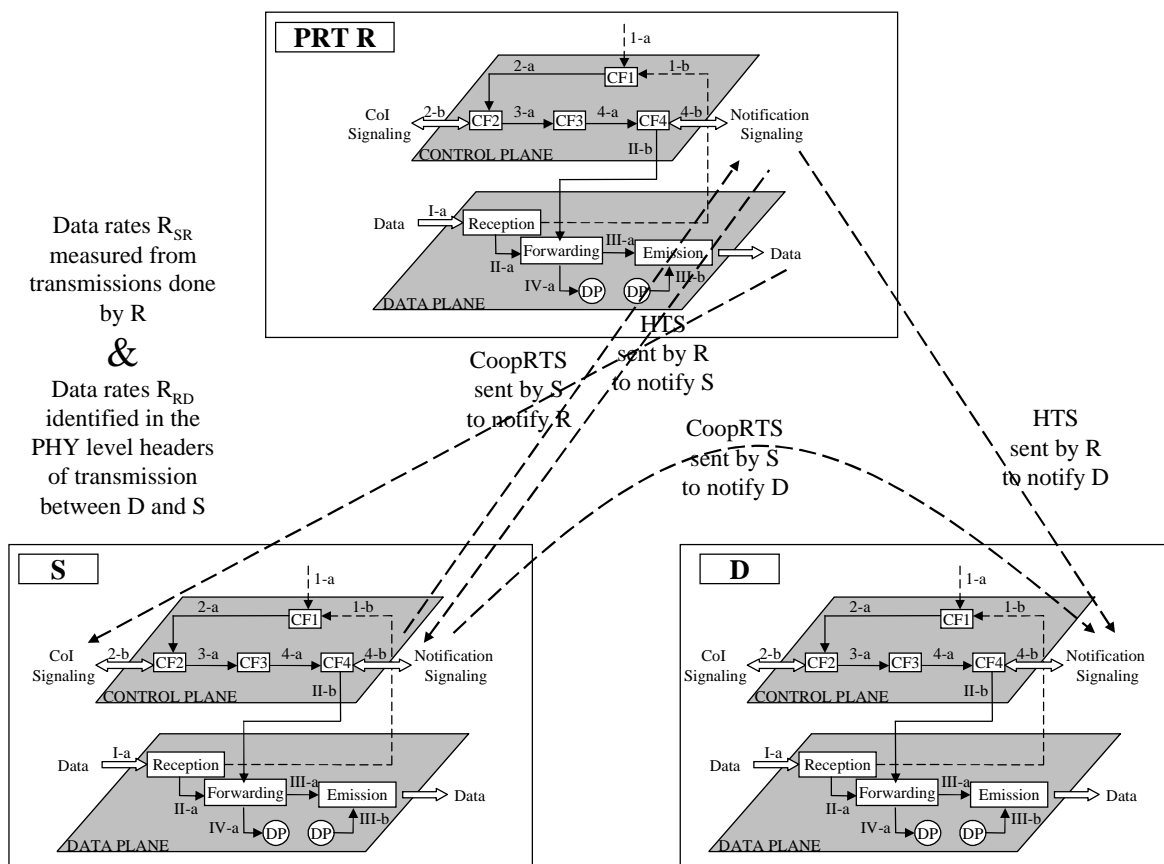

Figure 4.4.3.1: The control packet exchanges of CoopMAC based on cooperative network model.

Network model at the source terminal S

At the source terminal S, the cooperative setup is always activated at the CF1. The cooperative mode activation allows the CF2 block to communicate with the DP block in order to compute the data rates R_{SRi} and R_{RiD} by listening to all ongoing transmissions.

The data rate R_{SRi} is obtained from the frames emitted by the i^{th} PRT and listened by terminal S. The data rate R_{RiD} is identified from the PLCP headers of the physical level frames transmitted between the i^{th} PRT and terminal D (see Fig.4.4.3.2).

Fig.4.4.3.2 illustrates the interactions between the data plane and the control plane and the sequencing of the different block processes in the two planes of CoopMAC protocol. Again, a rounded rectangle blocks represents a data or a control frame while a cooperative function block in the control plane or the data plane of the cooperative network model is represented by a rectangular block.

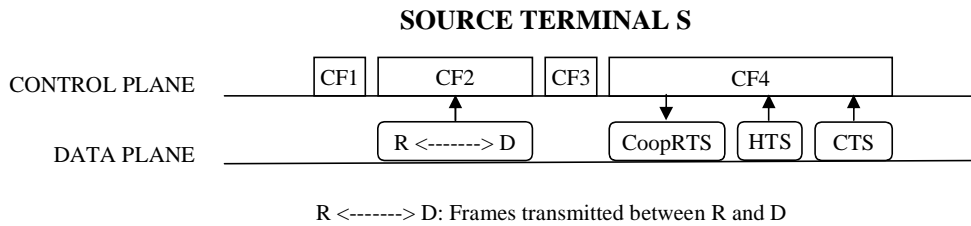

Figure 4.4.3.2: Data plane and control plane interactions of the CoopMAC protocol at the source terminal S.

The data rates R_{SR_i} and R_{RiD} and the terminal identity of each PRT are stored by the CF3 block of terminal S in the Helper Table. If there are any PRTs, which can provide higher transmission rate than the direct path, terminal S choose the best PRT to work as a relay terminal R. Whenever a data frame is emitted by terminal S, CoI (i.e., achievable data rates R_{SR} and R_{RD} and the terminal identity of the selected relay terminal R) is sent from the CF3 block toward the CF4 block and the DP block to create an in-band signaling (an adaptation of RTS frame with relaying information called CoopRTS), which is used to notify the cooperative transmission mode to the selected relay terminal R and the destination terminal D.

After sending the CoopRTS to notify terminal R and D, the CF4 block of terminal S waits for the reception of two frames: an HTS (Helper ready-To-Send) frame that acknowledges the cooperative participation of the selected relay terminal R, and a CTS frame that acknowledges the participation of the destination D.

Network model at the relay terminal R

In the control plane of the relay terminal R, CF1 block is empty because the cooperation mode is activated by default while CF2 and CF3 blocks are empty because CoI acquisition and relay selection are done at terminal S. The reception of the CoopRTS frame serves as a cooperative mode notification signaling to notify the CF4 block of terminal R through 4-b (see Fig.4.4.3.3).

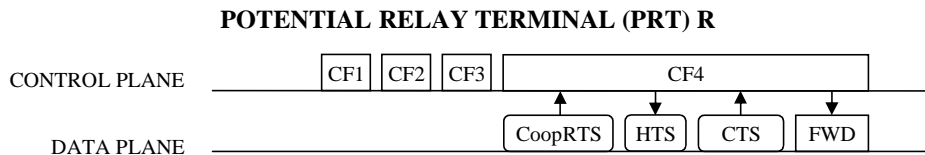

Figure 4.4.3.3: Data plane and control plane interactions of the CoopMAC protocol at a PRT R.

The data rates R_{SR} and R_{RD} indicated in the CoopRTS are check whether the terminal R is sustainable or not. If the required data rates can be provided, an HTS frame is sent to

4.5. CONCLUSION

Cooperative communications provide an efficient alternative to the MIMO techniques. However, to manage and setup cooperative networks, several tasks in different protocol layers must be implemented. For instance, the cooperative transmission is done at the physical layer whereas supervision processes such as cooperative mode activations, relay selections, and cooperative mode notifications are implemented at the MAC and/or network layers. In this chapter, we have proposed a “Cooperative Network Model”, at the system level. This framework is independent of the type of cooperative transmissions and cooperative setup. Therefore, the proposed model will help both the comparison of existing protocols and the design of future cooperative protocols.

Examples of the utilization of the proposed model have been given through the three chosen examples of cooperative setup protocols. We found that the proposed cooperative network model can clearly illustrate and describe every procedure of the selected cooperative setup protocols. In addition, the proposed cooperative network model facilitates us to find and solve limitations in cooperative setup designs. Thus, we believe that this model can facilitate the design and the improvement of existing and future propositions in this domain.

However, several important issues on cooperative setup designs remain to be addressed. The first one consists in deciding whether a cooperative communication mode could or should be connectionless or connection-oriented. If the radio channel varies very slowly, then a connection-oriented cooperative communication is achievable. Otherwise, connectionless communications are recommended. In any case, this issue must be solved to complete the design of a cooperative network.

Another important issue is the activation and de-activation of the cooperative mode in a network. Decision criteria should be developed to decide whether a cooperative communication should be implemented or not.

In the next chapters, “Cooperative Network Model” will be used to facilitate on a cooperative communication design. The design will be done in both of cooperative transmission and cooperative setup issues. The proposition of a cooperative transmission will be described in Chapter 5. The decision criteria to achieve cooperation will be studied. Then, the cooperative setup will be presented in Chapter 6 of this thesis.

Chapter 5

PROXY COOPERATIVE TRANSMISSION

(A PROPOSITION ON COOPERATIVE TRANSMISSION DESIGN)

Content

- 5.1. Proxy Cooperative (ProxyCoop) Transmission Background
 - 5.2. ProxyCoop Transmission
 - 5.3. Impacts of Channel Quality to ProxyCoop Performance
 - 5.3.1. System model
 - 5.3.2. Simulation results and analysis
 - 5.3.3. Confidence interval
 - 5.3.4. Conclusion
 - 5.4. Impacts of Channel Quality and Channel Availability to ProxyCoop Performance
 - 5.4.1. Interference topology
 - 5.4.2. System model
 - 5.4.3. Simulation results and analysis
 - 5.4.4. Conclusion
 - 5.5. Conclusion
-

This chapter and the following one present our proposition of cooperative communication technique called “*Proxy Cooperative Communication*”. It is composed of two parts, i.e., *Proxy Cooperative Transmission (ProxyCoop)* and *Proxy Cooperative Setup (ProxyCoopSetup)*. Details of ProxyCoop transmission design will be described in this chapter while details of ProxyCoopSetup will be explained in the next chapter.

The objective of ProxyCoop transmission is to design an adaptive cooperative transmission method, which is simple but effective. Thus, we designed a resource allocation based on the IEEE 802.11 MAC protocol [IEEE07] without any needs of control frames. ProxyCoop transmission is an adaptive method because it can automatically switch its transmission mode for each data frame between a cooperative transmission mode and a non-cooperative transmission one.

The source terminal sends its data in non-cooperative transmission mode. In case that there are erroneous data in the transmissions known by the absence of ACK frames, the relay transparently helps the source terminal in the sense that no data exchanges between the source terminal and the relay terminal are required. Instead of letting data re-transmissions done by the source terminal, the relay terminal acts as a proxy terminal, which is in charge of the data re-transmissions; thus, we named our proposition as a “***Proxy Cooperative Transmission (ProxyCoop)***”

In contrast to other adaptive cooperative transmission techniques, ProxyCoop can compatibly work with the IEEE 802.11 medium access method in both of the basic mode (also called two-hand shaking: Data/ACK) and the optional RTS/CTS mode (also called four-hand shaking: RTS/CTS/Data/ACK).

The interest of the proposition, shown by simulation, is to improve the transmission performance in term of packet delivery ratio (PDR), by decreasing the number of re-transmissions due to frame errors. Moreover, in multi hop wireless network the proposition alleviates inappropriate routing processes that are costly in time and resource. These processes look for a new route when a link is reported as broken by the 802.11 protocol, because a too high number of re-transmissions have been done.

Chapter Organization

After the presentation of the proposition functioning, the evaluation of ProxyCoop transmission is done by simulations. The simulations are separated into three parts: 1.) ProxyCoop transmission performance based on channel quality with a three-terminal network 2.) ProxyCoop transmission performance based on channel quality and channel availability with five-terminal networks (three terminals are formed as a cooperation system while the other two terminals generate interference to cooperation system) and a nine-terminal network (three set of cooperation systems are formed and each cooperation system interferes each others) 3.) 8-terminal networks are generated to study the impact of channel availability and relay choosing in ProxyCoop transmissions when a relay terminal has to relay data for a single or multiple transmission pairs.

For the performance analysis, the results are mainly analysed based on the Packet Delivery Ratio (PDR) and on the Number of Route Discovery and Maintenance (NRDM) per second. Finally the conclusion is presented.

5.1. PROXY COOPERATIVE TRANSMISSION (ProxyCoop) BACKGROUND

Link Failure and Multi-hop Network

Based on IEEE 802.11 MAC standard, re-transmission processes are required when error data frames are detected. Obviously, re-transmissions increase delay and decrease the packet delivery ratio (PDR) of the networks. More precisely, in ad hoc multi-hop networks, if the re-transmission counter (Re-Tx) in each link reaches a threshold, the link is assumed to be broken and a route recovery process is activated in order to find another route to send data from a source terminal (S) to a destination terminal (D).

For example, considering Ad-hoc On-Demand Distance Vector (AODV) routing protocol [PeRD03], the route recovery process is done by an AODV source-initiated route re-discovery method, S broadcasts a route request (RREQ) packet to re-find a route to D.

After route re-discovery processes, if the system remains its transmission mode in direct mode because the direct path (S to D) turns to have good link quality and D receives the RREQ packet sent from S (see Fig.5.1.1), it generates what we called *an unnecessary routing process*. The re-discovery processes choose to send data in the same route but the RREQ packets are re-broadcasted through the network. The network is flooded and is led to network congestion problem. Thus, the unnecessary routing processes are costly in time and resource.

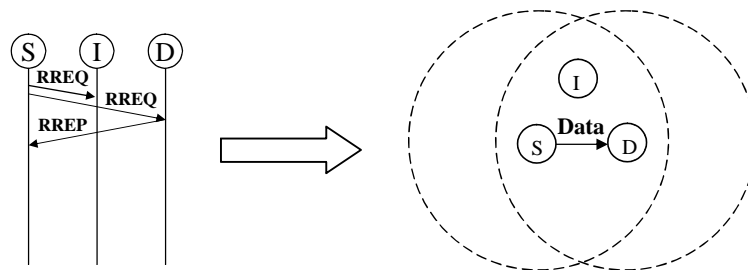

Figure 5.1.1: Direct transmission mode.

In addition, if the route re-discovery process occurs when the direct path is dropped, instead of receiving the RREQ packet from S, D receives the RREQ packet from an intermediate terminal (I) locating between S and D terminals. Thus, the transmission mode is switched from direct transmission mode to multi-hop transmission mode as shown in Fig.5.1.2. It generates what we called *a multi-hop transmission mode transition*. Rather than directly transmits a data frame from S to D in one time slot, the multi-hop transmission requires two time slots to send this data frame from S to I and from I to D, respectively. Therefore, similar to re-transmissions, multi-hop transmissions also increase the delay and decrease the PDR of the networks. Moreover, the interference area is expanded.

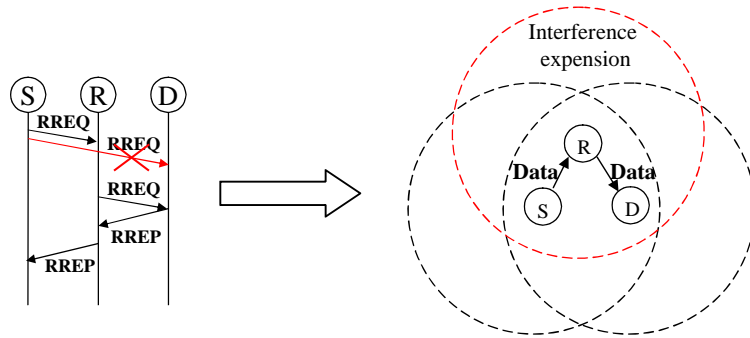

Figure 5.1.2: Multi-hop transmission mode.

Moreover, in multi-hop networks, routing protocols basically choose a route from S to D, which has the smallest number of hopcount meaning that the routing protocol try to choose a next-hop terminal, which has greatest distance from its previous terminal (see Fig 5.1.3).

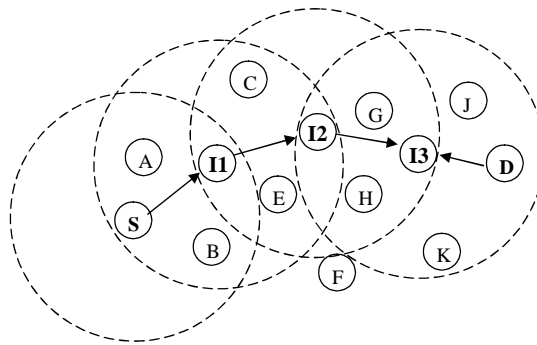

Figure 5.1.3: An example of Multi-hop network.

However, if channels are identical, the greatest distance means the least SNR since the SNR is a function to a distance between terminals. The SNR per bit for free-space can be calculated as shown in eqn. (5.1.1).

$$SNR = \left(\frac{\lambda}{4\pi} \right)^2 \frac{1}{d^2} |g|^2 |h|^2 \frac{E_b}{N_0} \quad (5.1.1)$$

where λ is the wavelength of the carrier signal, g is a shadowing fading gain, h is a Rayleigh fading gain, and E_b/N_0 is the energy per bit to noise power spectral density ratio and d is a distance between terminals. In digital communication, Bit Error Rate (BER) is an inverse function of SNR. Thus, the lower SNR, the higher BER. Therefore, we can

infer that the route acquired from routing protocol with lowest hopcount has large distance between terminals and has high BER. Thus, multi-hop transmission mode transitions can be easily occurred.

In contrast, since the distance between terminals in multi-hop path is usually shorter than the direct path, it is difficult to switch the transmission mode back from the multi-hop transmission mode to the direct one.

For example, focus on the transmission hop between I2 and I3, SNR_{I2I3} , which is the SNR from terminal I2 to I3, is equal or lower than SNR_{I2G} , SNR_{I2H} , SNR_{GI3} , and SNR_{HI3} . In addition, calculated from eqn. (5.1.1), if terminal G (for example) is located in the middle of I2 and I3, G_{I2G} , and G_{GI3} is four times higher than G_{I2I3} . Therefore, multi-hop transmission mode transition can be occurred easily but it is difficult to switch the transmission mode back to direct transmission mode.

Transition state diagram

The transition state diagram between the direct transmission mode and the multi-hop transmission mode in IEEE 802.11 MAC protocol is presented in Fig.5.1.4. Transmission modes can be switched from the direct transmission mode to the multi-hop one when the number of MAC re-transmission counter in the direct path ($Re-Tx_{Direct}$) exceeds a given threshold and a route recovery process is activated. After the route recovery process, transmission mode may remains in the direct transmission mode or may be switched to the multi-hop transmission mode depending on whether terminal D receives the RREQ packet from S or I.

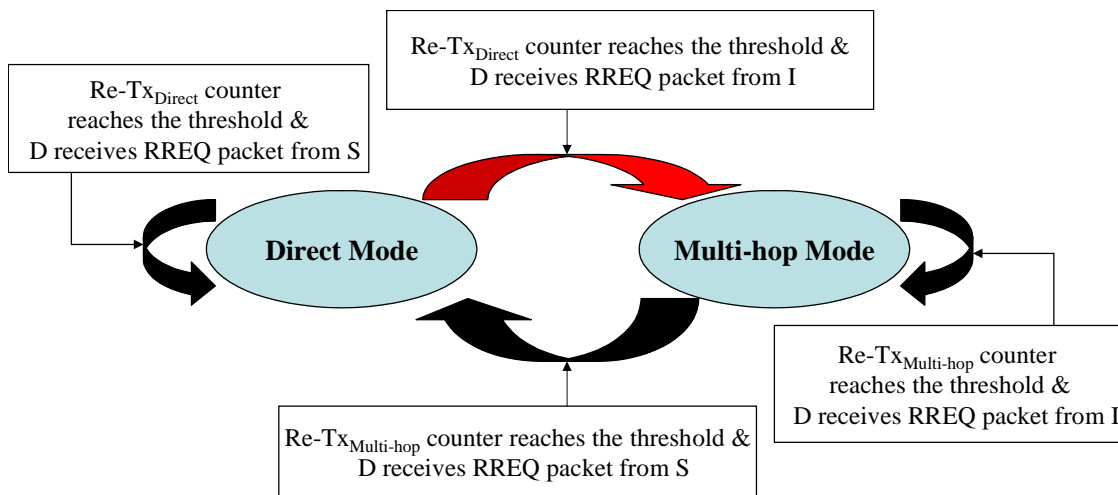

Figure 5.1.4: Transmission mode transition of non-cooperative transmission.

Since unnecessary routing processes and multi-hop mode transitions happen when the $\text{Re-Tx}_{\text{Direct}}$ counter reaches a threshold, transmission performance of the direct mode must be improved in order to reduce the number of re-transmissions. Therefore, we propose an adaptive cooperative transmission in order to improve the transmission performance by benefits of spatial diversity. The objective is to remain the transmission mode in the direct mode as long as possible. To verify that our proposition can minimize the number of multi-hop transitions, the simulations will be evaluated by the NRDM per second.

Adaptive method

In fixed cooperative transmissions such as [BoFY04], [LaTW04], and [BCGH06], cooperative transmission modes are always activated; thus, the medium is always reserved for data transmissions done by a source terminal and a relay terminal. The reservation causes problems of resource efficiency because cooperative transmission mode (see Fig.5.1.5b) consumes more medium resources than non-cooperative transmission mode (see Fig 5.1.5a). However, cooperative transmission mode is interesting when the performance of non-cooperative transmission is dropped and re-transmission processes are required (see Fig.5.1.5c). Therefore, adaptive cooperative transmissions, [LiTP05], [ISSL05], [JKFK07], and [IbHL07] for examples, have been proposed in order to activate cooperative transmission mode only when it is able to retain or improve transmission performance in the networks.

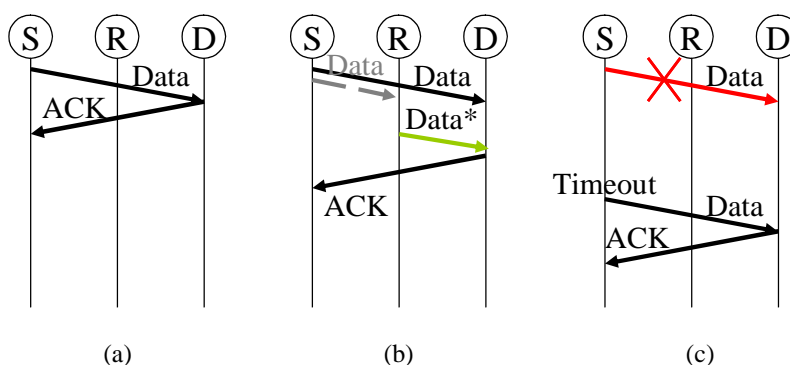

Figure 5.1.5: Message flows of (a) Non-cooperative transmissions (b) Cooperative transmissions and (c) Non-cooperative transmissions with re-transmission processes

To achieve an adaptive cooperative transmission design, based on cooperative network model as shown in Fig.5.1.6, the forwarding block on the data plane of each relay terminal must be only activated when cooperative transmission is needed. It is controlled by the CF4 (cooperative mode notification) block in the control plane through II-b. Thus, even the relay notification is a function of the control plane that will be presented in chapter 6 of this thesis, some details of the cooperative mode notification concerning ProxyCoop transmission with will be presented in this chapter.

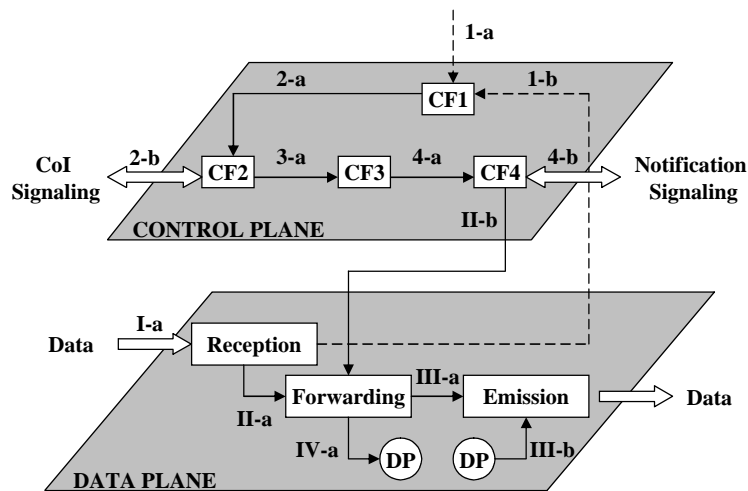

Figure 5.1.6: Cooperative Network Model.

The activation of adaptive cooperative data transmission

Whether the cooperative setup method is proposed to be operated only in MAC layer or Network layer and the relay selection method is centralized or distributed, the cooperative mode notification among terminals generally requires some additional control information exchanges (also called a notification signaling). The notification signaling may be done by additional control frames or additional information at the header of data frames. It is used to inform every cooperative participation terminals on the cooperation. After cooperative mode notifications are received, the CF4 block switches its transmission mode between a non-cooperative transmission mode and a cooperative one by informing its forwarding block in the data plane whether it has to work in cooperative data transmission or not.

Because our objective is to design a simple method being compatible with the standard, in order to switch on and off cooperative transmission modes, frame modifications are not required in our proposition. In addition, on the efficient issue, cooperative mode notification signaling is minimized. Even if the cooperative mode notification signaling is required in cooperative setup processes (chapter 6), there is no need of additional control frame exchanges for the cooperation in the data plane of our proposition. Relay terminals know that they have to relay the data by the absence of ACK frames.

5.2. PROXYCOOP TRANSMISSIONS

ProxyCoop is designed for a wifi network using an IEEE 802.11 MAC protocol. For interoperability purposes, rather than specifying a new protocol, benefit from the handshaking access mechanisms has been derived to activate the forwarding block to switch on or off its cooperative transmission mode based on the absence of ACK frames.

When there is no cooperation, as the data is sent from source to destination directly, it is named direct transmission mode. On the contrary, when the relay terminal helps on data relaying, it is called proxy cooperative transmission mode.

The principle of the proposition is presented in Fig.5.2.1. The two versions of the medium access methods of IEEE 802.11 protocol are considered; i.e., basic access method and optional one. S, R, and D stand for Source, Relay, and Destination terminals respectively. R is assumed to be chosen and located in the transmission ranges of S and D. Message flows of ProxyCoop, when it works with the basic access method are shown in Fig.5.2.1a and Fig.5.2.1b and with the optional access method are shown in Fig.5.2.1c and Fig.5.2.1d.

Fig.5.2.1a and Fig.5.2.1c represent ProxyCoop message flows when it works in direct transmission mode and when it works in proxy transmission mode are shown in Fig.5.2.1b and 5.2.1d.

The proposition is adaptive because its transmission mode is able to switch between direct transmission mode and proxy cooperative transmission mode. The appearance of an ACK frame informs R that the direct transmission is successful; thus, proxy mode is automatically turned off. The network transmission mode rests at direct transmission mode. R remains quiet and S continues to transmit its next data frame in the direct transmission mode as shown in Fig.5.2.1a and Fig.5.2.1c.

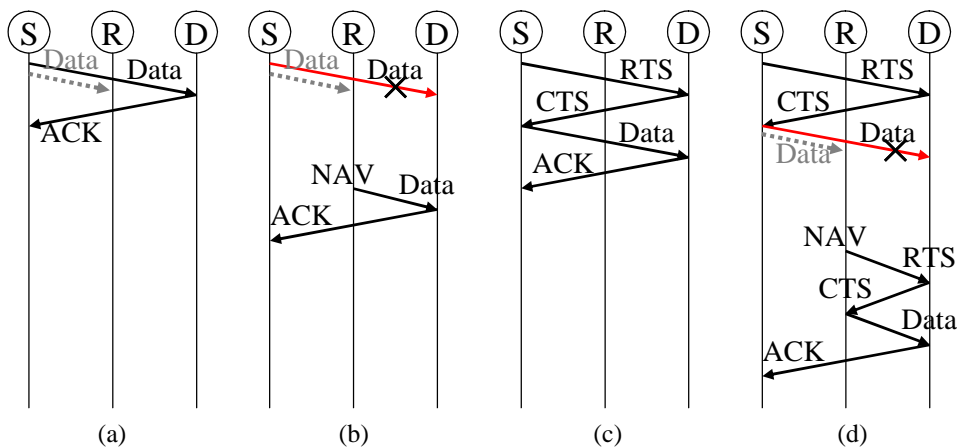

Figure 5.2.1: Message flows of ProxyCoop.

On the contrary, in Fig.5.2.1b and 5.2.1d, when D fails to decode a data frame and a network allocation vector (NAV) of R reaches to zero, the proxy transmission mode of the ProxyCoop is automatically turned on. Without any changes in the header of the data frame, R helps S to forward the data to D, and then the transmission mode of the network

is automatically switched back to the direct mode. If D successfully decodes the data sent from R, it replies an ACK back to S. The Re-Tx counter at S is reset, and then S sends its next data frame. When the Re-Tx counter is reset, probabilities of multi-hop mode transition are alleviated.

With the proposition, a new transmission state is introduced; i.e., proxy mode. Rather than to remain to re-transmit data in a direct mode, a re-transmission is done by a proxy mode as shown in Fig.5.2.2.

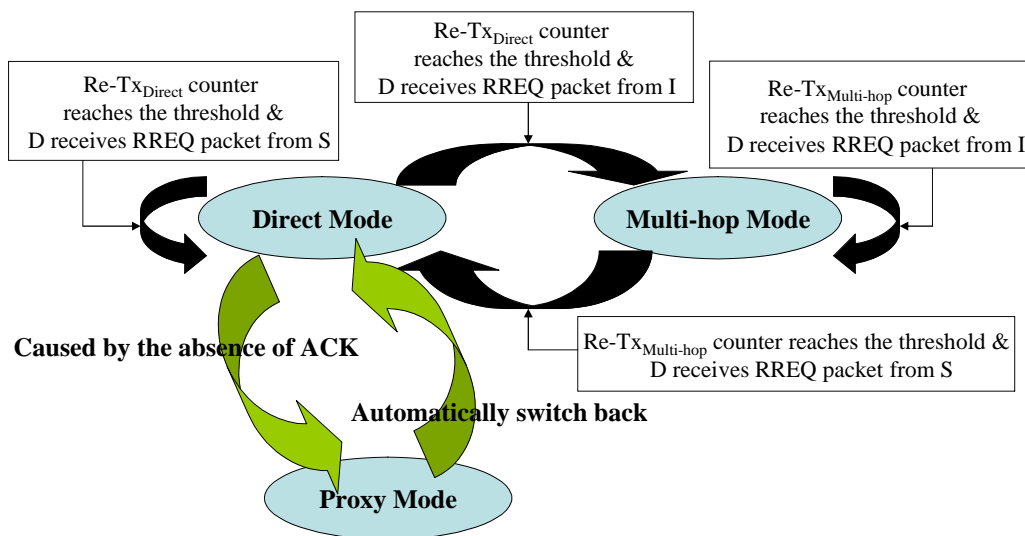

Figure 5.2.2: Transmission mode transition of ProxyCoop.

ProxyCoop and cooperative network model

Fig.5.2.3 illustrates ProxyCoop transmission through our cooperative network model when it works with basic access method of the IEEE 802.11 protocol. The DP of S prepares a data frame to send to D. Meanwhile, the forwarding block informs the emission block (through III-a) that it has to extend its re-transmission timeout. Then, the data frame is transmitted from the emission block of S to the reception block of D. Note that, the reception block of R can also overhear the data frame.

At terminal D, the data are sent to the forwarding block and passed to the DP to be processed. If D successfully decoded the data, the DP block of D prepares an ACK frame for its emission block. The ACK is sent from the Emission block of D to the Reception block of S. However, if D fails to decode the data sent from S, D keeps quiet. The ACK frame will not be sent from D to S.

At terminal R, the overheard data are sent from its reception block to its forwarding one. The data waits for an internal notification done by the CF4 block in its control plane

(through II-b). If the CF4 block of R overhears the ACK frame sent from D to S, R knows that the data frame transmission done by S is successful; thus, the forwarding block of R discards the data. In contrast, if the CF4 block of R cannot overhear the ACK frame sent from D to S, R assumes that the data frame transmission done by S is unsuccessful; thus, the forwarding block of R is notified (through II-b) to forward that data frame to its emission block. Since the design of ProxyCoop transmission allows terminal R to relay data to D through the MAC layer without any changes in the data frame header, the forwarding data frame can be directly sent from its forwarding block to its emission block (through III-a); the relayed data does not have to be processed through the DP block, which usually gains processing delays to the system.

If terminal D successfully decodes the relayed data transmitted by R, similar to the case when D successfully decodes data sent by S, the data will be passed from the reception block to the forwarding block and to the DP to be processed. Then, an ACK frame is generated and transmitted back from terminal D to terminal S.

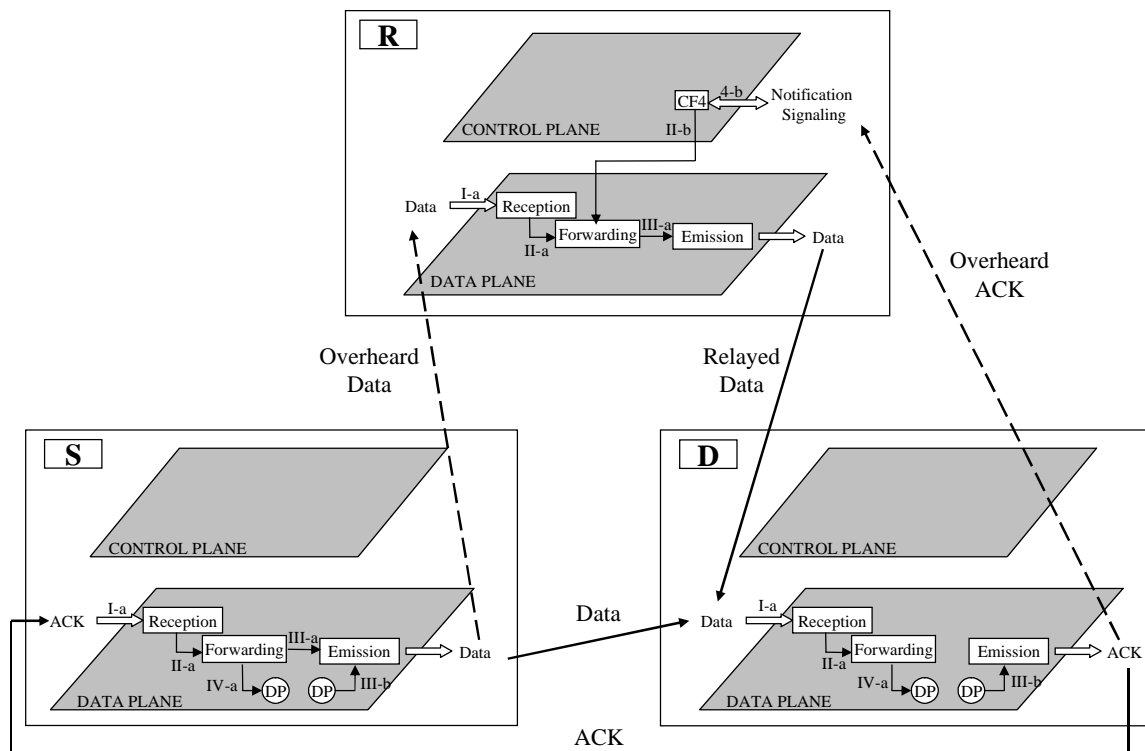

Figure 5.2.3: ProxyCoop transmission with basic access method of IEEE 802.11 MAC protocol on the cooperative network model.

Supporting Basic and Optional access modes

In adaptive cooperative transmissions, generally inspired from the IEEE 802.11 MAC standard, the activation and deactivation of these cooperative transmission modes require

extra control frames, which are modified from RTS and/or CTS frames ([LTNK07] and [ZhCa06]) and/or are created in new frame formats ([AzAA05] and [ZhZJ09]). These adaptive cooperative transmissions cannot be implemented in IEEE 802.11 networks with basic access mode and also have interoperability problems with legacy systems.

In contrast to these transmission methods, without any need of notification frames, ProxyCoop transmission mode can be automatically switched between direct and proxy transmission modes; thus, RTS and/or CTS utilization and modification are not required. This property allows ProxyCoop to be able to work with both of the basic and optional access modes of the IEEE 802.11 protocol.

This issue is interesting because the standard indicates that the RTS/CTS mechanism needs not to be used for every data frame transmission especially for short data frames. The RTS/CTS frames cause overhead inefficiency to the systems.

Single relay selection

Transmission performance in term of bit error rate gains benefit from spatial diversity properties when the number of relay terminals is increased. However, cooperative transmissions consume more medium when the number of relays increases since the wireless medium is shared among cooperative participating terminals (i.e. source, relays, and destination). In addition, [BISZ07] shows that, in some cases, the outage behaviour of cooperative communications with single best relay selection can perform equivalently with cooperative communications that employ all potential relay terminals.

Therefore, rather than using a set of relay terminals, ProxyCoop save the medium utilization by using only one relay terminal. The relay terminal is assumed to be chosen. Details of relay acquisitions and relay selections, which are parts of cooperative setup, will be described in depth in Chapter 6.

ProxyCoop Table

A MAC layer table is specified at terminal R in order to allow R to be able to filter and relay data frames sent from S to D correctly. MAC addresses of the transmission pair (S and D) are indicated in the table. These addresses are acquired by AODV routing protocols in the network layer. Details of ProxyCoop table and filling method will be described in depth in Chapter 6.

MAC Layer Relaying

For data relaying, in contrast to typical multi-hop transmission where data are forwarded through the network layer, ProxyCoop allows R to relay data through its MAC layer as used in [ZhC06]. R acts as a dynamical bridge since forwarded data frames do not need to be sent up to the network layer. The forwarding scheme of ProxyCoop is a ***selective-and-forward method***. R relay the data to D only if the relayed data are correct. R directly forward exactly the same data frame, received from S, to D through its MAC layer. In addition, after data forwarding, R does not need to wait ACK frames from D.

MAC layer relaying is more interesting since it has less and delay compared to Network layer forwarding because it does not have queuing delays and processing delay (such as de-encapsulation and re-encapsulation). In addition, MAC layer relaying has less overhead than Network layer forwarding. In our proposition, each relay terminal treats relayed data (received from a source terminal) and transmitted data (produced by the relay terminal itself) separately. Since the relayed data must be forwarded immediately after the data have been sent by the source terminal, the relayed data are kept in a specific buffer. They do not have to enter the queuing process as the transmitted data.

Acknowledgement method

In cooperative transmission mode of CoopMAC [LTNK07], S unicastly sends a data frame to R, R forwards that data frame to D, and then D unicastly replies an ACK frame to S (see Fig.5.2.4a). The source and destination MAC addresses of the data frame sent from S to R are the MAC address of S and R respectively while the source and destination MAC addresses of the data frame forwarded from R to D are the MAC address of S and D. Thus, when D receives the forwarded data, D directly replies an ACK frame to S (not to R). However, [LTNK07] indicates that when CoopMAC protocol is implemented on an 802.11b wireless driver called HostAP, it has problems on ***the duplication of ACK frames***. Since the acknowledgement mechanism is an integral function of firmware, it is impossible to suppress the unnecessary ACK generated by the relay terminal meaning that S will receive the ACK frame two times; i.e., the ACK is sent by R and D (see Fig.5.2.4b).

In the handshaking process, when S receives an ACK from R, it stops to wait for the ACK frame and prepares to transmit its next data frame. Thus, when S receives a duplicated ACK sent from D, it cannot interpret this event since it does not wait for any ACK frames. Thus, the duplicated ACK causes problem on the handshaking process in the MAC protocol. If the number of duplicated ACK frames reaches a given threshold, a route re-discovery or maintenance process is activated.

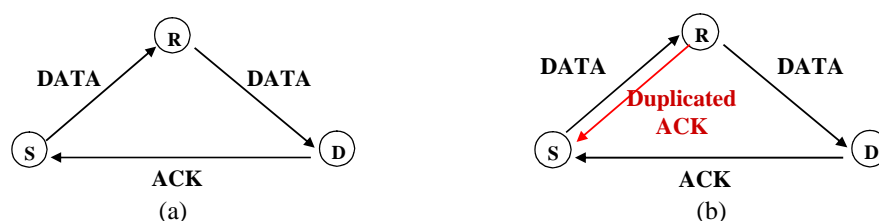

Figure 5.2.4: Data transmissions of CoopMAC (a) in the design and (b) in the implementation.

In contrast, in proxy cooperative transmission mode, if D fails to receive data from S (known by the absence of ACK frames), R helps S on forwarding ***the overheard data frame*** to D. Since the source and destination MAC addresses of the overheard data frame are the MAC address of S and D, R does not have to reply an ACK frame to the

overheard data frame. Therefore, S will receive the ACK frame just only one time from D when it successfully receives data from S or R.

Extended Timeout in ProxyCoop

If D unsuccessfully received data sent by S or an ACK frame sent from D is lost, S waits until its re-transmission timer (called Timeout) reaches to zero, and then the data is re-transmitted. To prevent collision between re-transmissions done by S and cooperative transmissions done by R, S must extend its timeout to cover the ACK frame sent by D when it successfully decodes data frames forwarded by R.

In addition, to allow R to acquire medium faster than other terminals when it operates in proxy mode, its defer backoff is set to zero. The basic and optional access methods of ProxyCoop are respectively illustrated in Fig.5.2.5 and Fig.5.2.6.

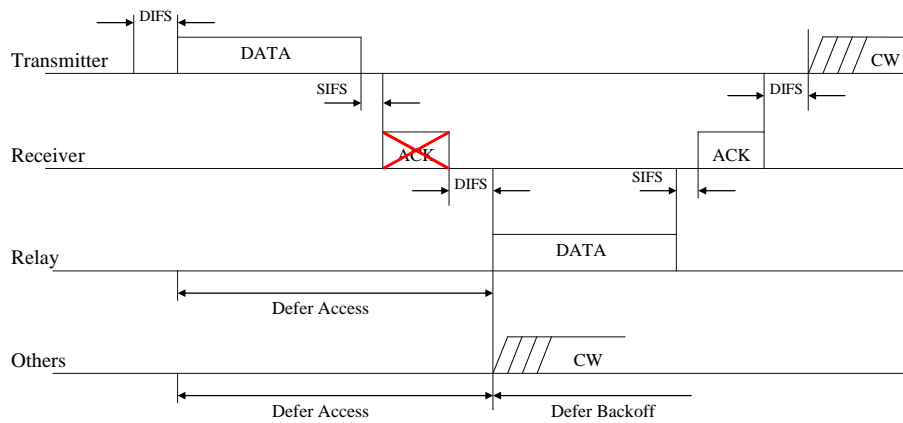

Figure 5.2.5: Basic access method when defer backoff of the relay terminal is set to zero.

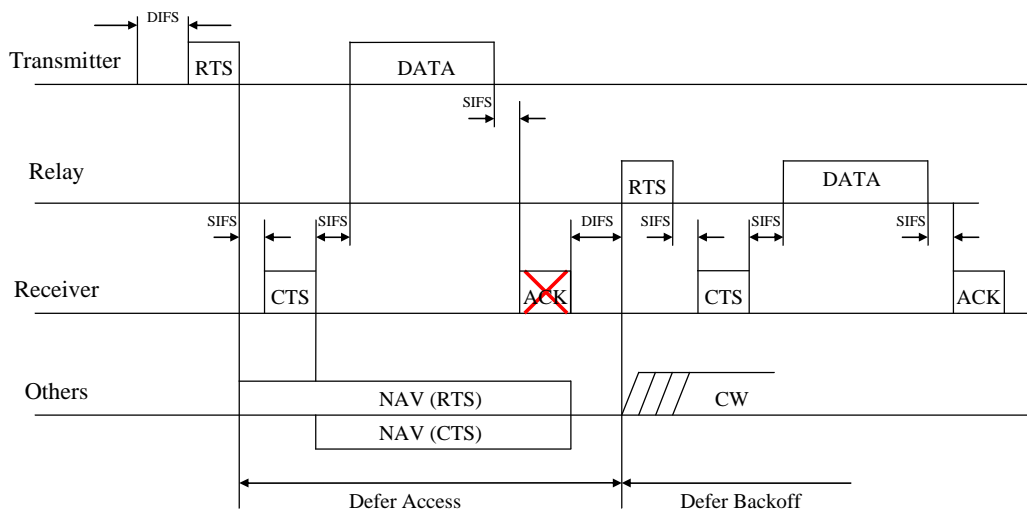

Figure 5.2.6: Optional access method when defer backoff of the relay terminal is set to zero.

SIFS stands for short interframe space while DIFS stands for distributed coordination function interframe space. The defer backoff is proposed to minimize collision during contention among multiple mobile terminals that have been deferring to the same period. The value of Defer Backoff Time (DBT) can be calculated as in eqn.(5.2.1).

$$DBT = \text{Random}() \times \text{TimeSlot} \quad (5.2.1)$$

Where $\text{Random}()$ is a Pseudo-random integer drawn from a uniform distribution over the interval $[0, CW]$. CW is a contention window. It is an integer within the range of $[CW_{\min}, CW_{\max}]$. TimeSlot is a time value of each time slot [IEEE07]. The Network Allocation Vector (NAV) maintains a prediction of future traffic on the medium based on duration information that is announced in RTS/CTS frames. Note that ProxyCoop does not use or modify RTS/CTS frames. Thus, the duration information that is announced in RTS/CTS frames of ProxyCoop is as same as those of IEEE 802.11 MAC standard. For conclusion, in IEEE 802.11 MAC protocol, ProxyCoop only extends the timeout at terminal S and sets the defer backoff at terminal R to be zero.

More precisely, the extended timeout is calculated as follows. In both of the basic and the optional access modes of IEEE 802.11 MAC protocol, S sets its timeout when it sends a data frame to D. The timeout covers a data propagation delay sent by S (T_{Data}), a SIFS (T_{SIFS}), and an ACK propagation delay sent by D (T_{ACK}) as indicated in eqn. (5.2.2).

$$\text{Timeout} = T_{\text{Data}} + T_{\text{SIFS}} + T_{\text{ACK}} \quad (5.2.2)$$

However, in ProxyCoop based on basic access method as shown in Fig.5.2.5, when S sends a data frame to D, it must extend its timeout to cover a data propagation delay sent by S (T_{Data}), a SIFS (T_{SIFS}), an ACK propagation delay sent by D (T_{ACK}), a DIFS (T_{DIFS}), a data propagation delay sent by R (T_{Data}), a SIFS (T_{SIFS}), and an ACK propagation delay sent by D (T_{ACK}). The extended timeout of the basic access mode ($\text{Timeout}_{\text{Ext_Basic}}$) is indicated in eqn. (5.2.3). The data propagation delays sent by S and by R are assumed to be equal; thus, we named them similarly as T_{Data} .

$$\text{Timeout}_{\text{Ext_Basic}} = T_{\text{Data}} + T_{\text{SIFS}} + T_{\text{ACK}} + T_{\text{DIFS}} + T_{\text{Data}} + T_{\text{SIFS}} + T_{\text{ACK}} \quad (5.2.3)$$

In ProxyCoop based on optional access method as shown in Fig.5.2.6, when S sends a data frame to D, it must extend its timeout to cover a data propagation delay sent by S (T_{Data}), a SIFS (T_{SIFS}), an ACK propagation delay sent by D (T_{ACK}), a DIFS (T_{DIFS}), a RTS propagation delay sent by R (T_{RTS}), a SIFS (T_{SIFS}), a CTS propagation delay sent by D (T_{CTS}), a SIFS (T_{SIFS}), a data propagation delay sent by R (T_{Data}), a SIFS (T_{SIFS}), and an ACK propagation delay sent by D (T_{ACK}). The extended timeout of the optional access mode ($\text{Timeout}_{\text{Ext_Optional}}$) is indicated in eqn. (5.2.4).

$$\begin{aligned} \text{Timeout}_{\text{Ext_Optional}} = & T_{\text{Data}} + T_{\text{SIFS}} + T_{\text{ACK}} + T_{\text{DIFS}} + T_{\text{RTS}} & (5.2.4) \\ & + T_{\text{SIFS}} + T_{\text{CTS}} + T_{\text{SIFS}} + T_{\text{Data}} + T_{\text{SIFS}} + T_{\text{ACK}} \end{aligned}$$

Non-combining Signals

For simplicity, the received signals of ProxyCoop at the destination terminal transmitted by S and R are not combined. This technique is used in [LiTP05], [KNBP06], [LTNK07] and [ZhCa06]. If signal combinations at signal-level are needed, signal combiners such as maximum ratio combiners require fading amplitudes and phase compensations of source to destination and relay to destination channels [Proa95]. These requirements cause system complexities. Moreover, additional hardware such as a signal combiner at the receiver side is required and it adds cost to the system.

Cooperative forwarding scheme

In proxy transmission mode, the chosen relay terminal relays data with decode and forward scheme when the received data are correct. Otherwise, it will keep quiet. The relay terminal can verify data correction by using Cyclic Redundant Check (CRC) or measuring the received SNR.

5.3. IMPACTS OF CHANNEL QUALITY TO PROXYCOOP PERFORMANCE

This section evaluates the interest of ProxyCoop by simulation under Network Simulator (NS) 2. [NeSi10]. A simple system with three terminals is considered. Next section will consider the interferences from other terminals.

Since the interest of ProxyCoop transmission is connected to the channel quality, the error probabilities of paths between each terminal are varied and the impacts of channel quality to the ProxyCoop performance are studied.

5.3.1. System Model

The performance of ProxyCoop is evaluated by simulations and compared with a non-cooperative transmission. The performance evaluation is done with two metrics. Firstly, the transmission performance is evaluated in terms of PDR. Secondly, the administrative (routing) performance is evaluated in terms of the NRDM per second.

AODV is used for the routing protocol [PeRD03]. In case of link failures, the route recovery process is done by an AODV source-initiated route re-discovery method, the source terminal (S) broadcasts a RREQ packet to re-discover a route to the destination terminal (D). NRDM is the number of route RREQ packets sent by S to discover and re-discover a route from S to D during the simulations.

A simple scenarios of 3-terminal network as shown in Fig.5.3.1.1 is simulated. There are no interferences from other terminals. R and D are in the coverage area of S. R is assumed to be already chosen, and it is located in the transmission range of S and D. The two-ray ground propagation model is used for physical channel and the medium access is done by IEEE 802.11 MAC protocol. The radio channels are slowly time-varying. User Datagram Protocol (UDP) agents are created to send Constant Bit Rate (CBR) traffic with data rate 448 kbps and packet size is 210 bytes. Simulation time is 100 seconds.

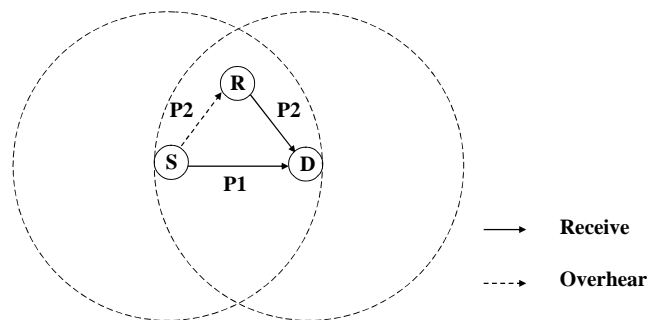

Figure 5.3.1.1: A 3-terminal network.

A probability error of 0.1 and 0.2 per frame are set for the direct path (S to D), while each transmission hop of the proxy path (i.e., S to R and R to D as shown in Fig.5.3.1.1) have their error probabilities (P2) varying from 0.05 to 0.4 per frame.

Direct path error

The error probabilities of the direct path (P1) are set to 0.1 and 0.2 in order to generate two different scenarios during the simulations. When P1 equals to 0.1, multi-hop mode transitions do not occurred in the non-cooperative transmission. When P1 equals to 0.2, transmission errors in the direct path cause multi-hop transmission mode transitions to the non-cooperative transmission. Multi-hop transmission mode transitions occur when S changes its transmission mode from direct transmission mode (S to D) to multi-hop transmission mode (S to R to D).

Proxy path error

Variations of the error probability in each hop in the proxy paths (P2) are set in order to study the performance of ProxyCoop, when the total channel quality of the proxy path is better or worse than the direct path.

Transmission modes

Non-cooperative transmissions have two transmission modes (i.e., direct and multi-hop transmission modes) as shown in Fig.5.3.1.2a and Fig.5.3.1.2b respectively. In ProxyCoop, its transmission modes can be switched among three modes as shown in

Fig.5.3.1.3. ProxyCoop can switch its transmission mode among three transmissions modes; 1) Direct transmission mode 2) Proxy cooperative transmission mode and 3) Multi-hop transmission mode, as respectively shown in Fig.5.3.1.3a, Fig.5.3.1.3b, and Fig.5.3.1.3c.

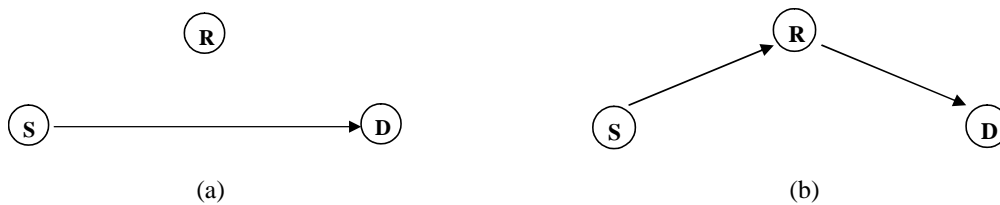

Figure 5.3.1.2: Non-cooperative transmission in (a) Direct transmission mode and (b) Multi-hop mode.

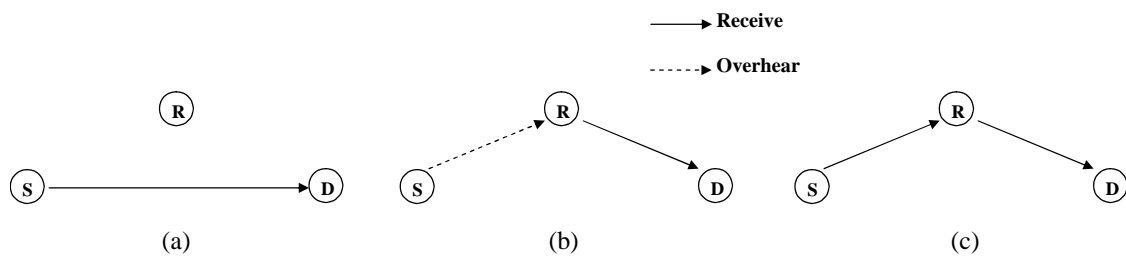

Figure 5.3.1.3: ProxyCoop in (a) Direct transmission mode (b) Proxy cooperative transmission mode and (c) Multi-hop mode.

5.3.2. Simulation Results and Analysis

In the 3-terminal network, when $P1=0.1$, there is no multi-hop transmission mode transition in both of non-cooperative and ProxyCoop transmissions; thus, the percentages of data frames sent in multi-hop mode equal to zero as shown in Fig.5.3.2.1. The x-axis represents values of $P1$ over $P2$ ($P1/P2$). $P1$ is set at 0.1 per frame and $P2$ is varied from 0.05 to 0.2 per frame. Note that on the left-hand side of the graph, channel quality of the proxy path is worse than that of the direct path. In contrast, on the right-hand side of the graph, channel quality of the proxy path is better than that of the direct one.

When $P1=0.2$, multi-hop transmission mode transitions occur in the non-cooperative transmission but not in the ProxyCoop. The percentage of data frames in ProxyCoop that are sent in multi-hop transmission mode equals to zero while that of the non-cooperative transmission are increased to more than 20%, as shown in Fig.5.3.2.2. Thus, the result shows that ProxyCoop can alleviate probabilities of multi-hop mode transitions.

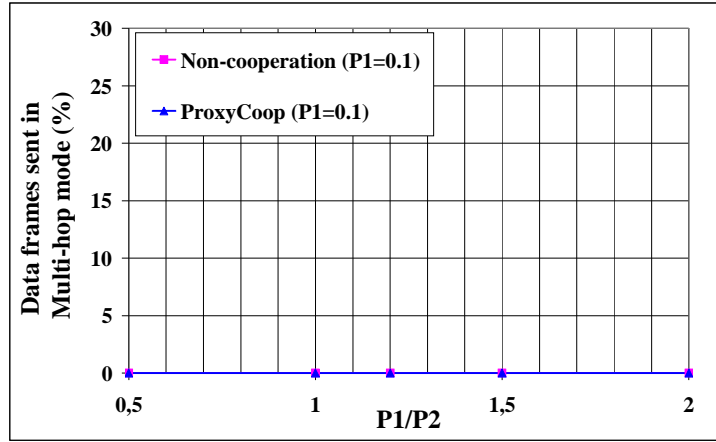

Figure 5.3.2.1: Percentage of data frames sent in multi-hop mode when $P_1 = 0.1$.

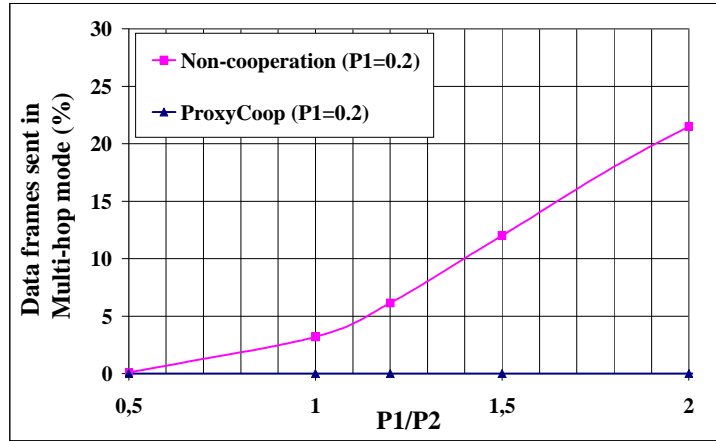

Figure 5.3.2.2: Percentage of data frames sent in multi-hop mode when $P_1 = 0.2$.

Fig.5.3.2.3 illustrates the NRDM per second of non-cooperative and ProxyCoop transmissions when $P_1=0.1$. As shown in Fig.5.3.2.3, the value of the NRDM per second of ProxyCoop is globally lower than that of the non-cooperative transmission because the transmission performance of ProxyCoop is increased. ProxyCoop gains probability of correct data reception at the destination when the link quality of the proxy path is better than the direct path one. Equation (5.3.2.1) and (5.3.2.2) respectively show the probabilities of correct data reception at D for the non-cooperative and proxy cooperative transmissions.

$$P_{correct}^{Direct} = 1 - P_1 \quad (5.3.2.1)$$

$$P_{correct}^{Proxy} = (1 - P_1) + P_1(1 - P_2)^2 \quad (5.3.2.2)$$

The performance gain of ProxyCoop is shown in eqn. (5.3.2.2). The first term is the probability that D can successfully decode the data frames sent by S. The second one is related to the probability that D fails to receive data by S but it successfully decodes the data sent by R. This gain increases probability of correct data reception at D.

Therefore, on the right-hand side of Fig.5.3.2.3, when channel quality of the proxy path is higher than the direct path, ProxyCoop can reduce the number of re-transmissions at the source terminal. Thus, the number of route re-discovery and maintenance is reduced.

In contrast, on the left-hand side of Fig.5.3.2.3, when channel quality of the proxy path is worse than that of the direct path, the NRDM per second of ProxyCoop is higher than that of the non-cooperative transmission. The channel imperfection causes R to miss-hear ACK packets. Thus, R causes confusion in the handshaking method. In precisely, when D successfully decodes a data frame sent by S and an ACK is sent back to S. The ACK informs S that the transmission is successful and S prepares to send its next data frame. However, since the channel qualities of the proxy paths are very poor, R cannot hear the ACK frame and it assumes that the transmission done by S is failed; therefore, R relays the data frame to D. When D successfully decodes the data frame sent by R, it discards the duplicated data because it has already received the data sent by S. Nevertheless, D sends an ACK back to S because the data frame is sent by the MAC layer relaying method; thus, D cannot recognize whether the data frame is sent by S or R. When S receives the duplicated ACK frame, it marks as a miss state on handshaking processes. If the number of the miss state reaches a threshold, it conducts the routing layer to process route maintenances. Thus, the duplicated ACK increases the NRDM in ProxyCoop.

The NRDM of the non-cooperative transmission when $P1=0.1$ is nearly constant because the $P1$ is not large enough to switch the data transmission through the multi-hop path. Thus, the NRDM is only the function of $P1$, which is constant.

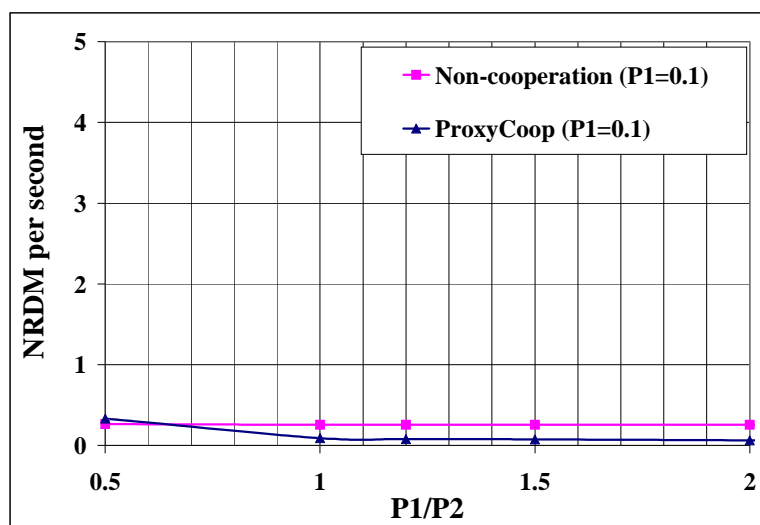

Figure 5.3.2.3: NRDM per second when $P1 = 0.1$.

Similar to Fig.5.3.2.3, the NRDM per second of ProxyCoop, as shown in Fig.5.3.2.4 when $P_1=0.2$, is decreased when channel quality of the proxy path is increased. However, if channel quality of the proxy path is worse than the direct path, its NRDM per second is increased because the miss state on handshaking caused by duplicated ACK frames.

The NRDM per second of the non-cooperative transmission in Fig.5.3.2.4 is decreased because non-cooperative transmission switches its transmission mode to multi-hop mode. When proxy paths have good channel quality, data transmissions in multi-hop transmission mode well perform. The non-cooperative transmission remains to transmit in the multi-hop transmission mode longer (know by the increment of the data percentages that are sent in multi-hop mode in Fig.5.3.2.2). Therefore, the NRDM per second of the non-cooperative transmission is decreased.

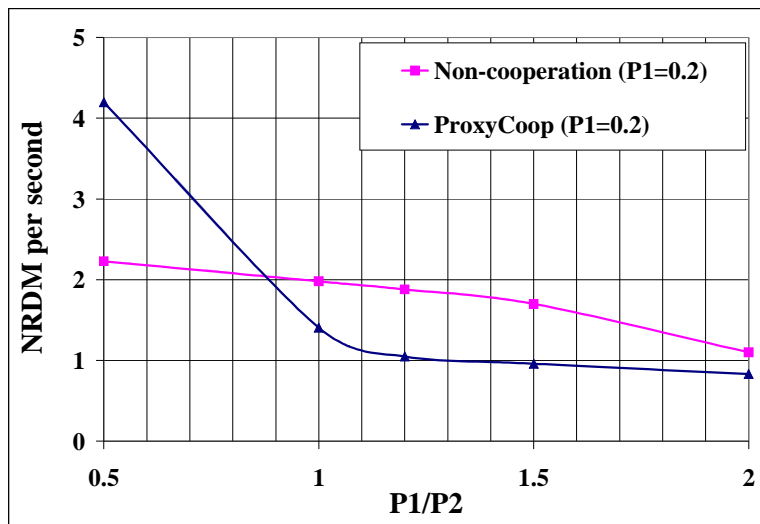

Figure 5.3.2.4: NRDM per second when $P_1 = 0.2$.

Fig.5.3.2.5 shows the PDR of non-cooperative and ProxyCoop transmissions when $P_1=0.1$ and P_2 is varied from 0.05 to 0.2. The PDR of the non-cooperative transmission is nearly constant because, when $P_1=0.1$, there is no multi-hop transmission mode transition. All data are sent through the direct path. Therefore, the PDR of non-cooperative transmission is only a function of P_1 , which is constant.

The PDR of ProxyCoop is lower than those of the non-cooperative transmissions because of two major reasons. First, because of the collisions generated by R when it missed-hears ACK packets. R competes with S on data transmissions. Second, due to the extended re-transmission time introduced by the inefficient relay transmission; i.e., R has to help S on data relaying, but it is also unable to decode the data frame; thus, D has to wait for the re-transmission done by S after the extended timeout, which is approximately twice longer than that of the non-cooperative technique, reaches to zero. Nevertheless, when the link quality of the proxy path is increased, the PDR of ProxyCoop is continually increased since the relay terminal can perform its proxy transmission mode efficiently.

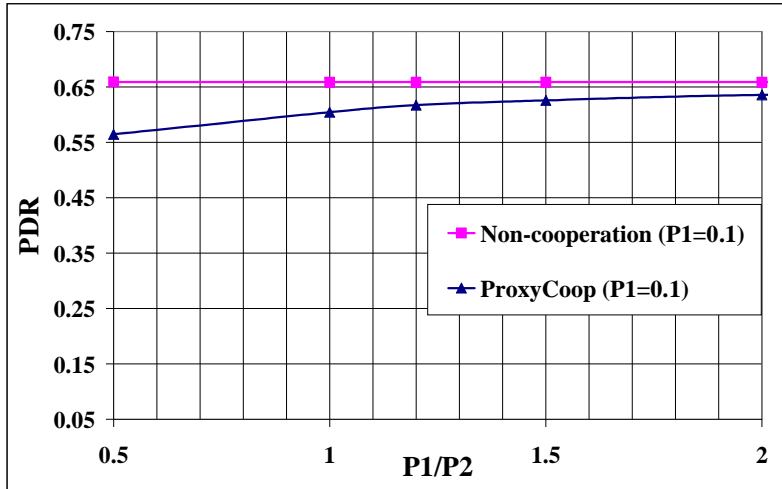

Figure 5.3.2.5: PDR when P1 = 0.1.

Similar to Fig.5.3.2.5, when the link quality of the proxy path is increased, the PDR of ProxyCoop in Fig.5.3.2.6 is continually increased and in some ranges of P1/P2, ProxyCoop provides higher PDR than that of the non-cooperative transmissions.

When P1=0.2, non-cooperative transmission switches its transmission mode from the direct mode to the multi-hop one. The more the percentage of data frames sent in multi-hop transmission mode of non-cooperative transmission is increased (see Fig.5.3.2.2), the more the PDR of non-cooperative transmission is decreased as shown in Fig.5.3.5.6. Non-cooperative transmission loses its performance because, instead of sending a data frame in one time slot from S to D as used in direct transmission mode, multi-hop transmission requires two time slots to send a data frame from S to R and from R to D.

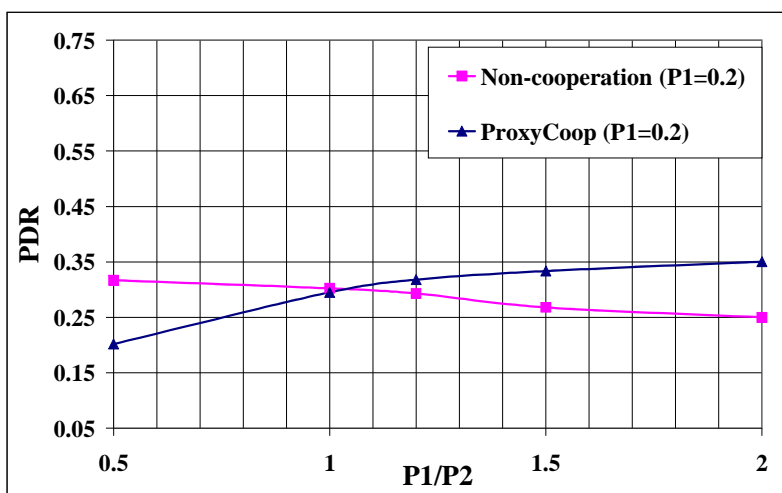

Figure 5.3.2.6: PDR when P1 = 0.2.

From simulation results, we can conclude that ProxyCoop is interesting as it provides a better PDR than the non-cooperative transmission when the link quality of the proxy path is better than the direct path and there are probabilities of multi-hop transmission mode transitions.

5.3.3. Confidence Interval

The statistic value called Confidence Interval (CI) is used to indicate the reliability of the simulation results. For example, when simulation results are stated at 95% confidence level, the confidence limits of PDR when $P1=0.2$ are as shown in Fig. 5.3.3.1. Points around the graphs are maximum and minimum confidence limits of each simulated point. The CI calculation of each simulated point is done based on 50 samplings of each simulated point. Since the confidence limits of each simulation value are small (i.e., 0.50% - 1.37 % compared with the mean value), it can be said that our simulation results are reliable.

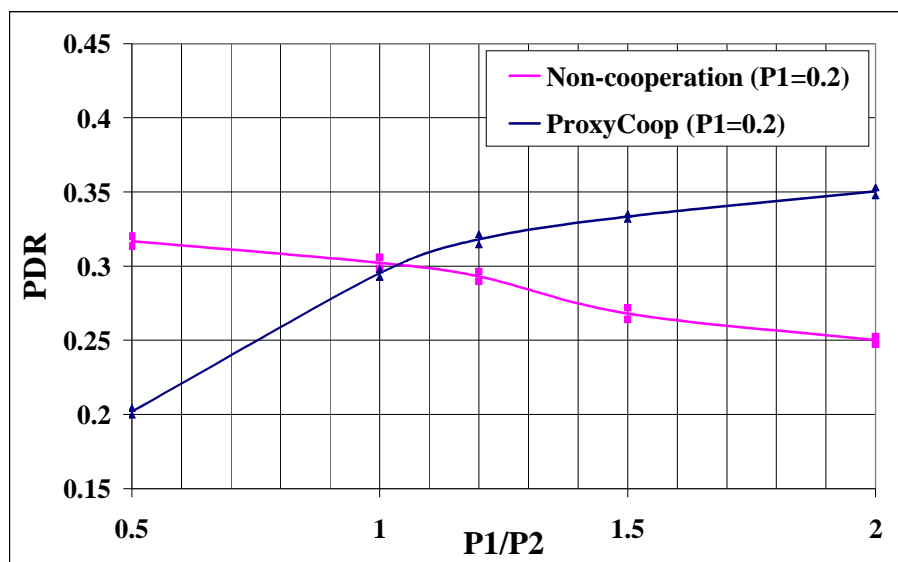

Figure 5.3.3.1: PDR when $P1 = 0.2$ with maximum and minimum confidence limits.

5.3.4. Conclusion

In this part of thesis, the proposition has been simulated for a wireless mesh network. The impacts of channel quality to the performance have been studied not only in the MAC level but also in the network one with its routing process. From simulation results, it shows that ProxyCoop outperforms the non-cooperative transmissions in terms of transmission performance (evaluated by PDR) and in terms of routing performance (evaluated by NRDM per second), when there are probabilities of multi-hop transmission mode transition in non-cooperative transmissions and when a “good” relay terminal is chosen to work in a proxy transmission mode. A “good” relay means a terminal located

in the transmission range of a source and a destination and having the link qualities of its proxy paths better than the direct path one.

Therefore, in order to improve the performance of ProxyCoop transmission, rather than to be switched based only on the absence of ACK frames, the transmission mode of ProxyCoop should be also switched based on channel qualities of the direct path and multi-hop paths. The channel quality can be collected by measuring the SNR of every frame in the ongoing transmissions or observing the SNR from routing packets during the routing process by cross-layering. If the channel distribution of the direct path corresponds to a pattern where there are chances of multi-hop transmission mode transitions, the proxy mode should be turned on. In contrast, if the channel distribution of the direct path corresponds to a pattern where there is no multi-hop transmission mode transition, then the proxy mode should not to be used since it is more costly to re-transmit by the relay than the source terminal. However, even if the prevision of the channel distribution of the direct path is not accurate (the proxy mode is activated while there is no multi-hop transmission), the drawback is not significant because the cost increased by ProxyCoop transmission is small. In addition, note that if the signals sent by S and R of ProxyCoop transmission are combined, its performance (in both of the PDR and the NRDM per second) is increased but its complexities are increased.

5.4. IMPACTS OF CHANNEL QUALITY AND CHANNEL AVAILABILITY TO PROXYCOOP PERFORMANCE

From previous part of this chapter, the interest of ProxyCoop transmission connected to the channel quality has been studied. In this part, impacts of channel quality and channel availability to the performance of ProxyCoop transmission will be described.

5.4.1. Interference Topology

The channel availability is modeled by the presence of neighbor terminals. We separate the interference topology in two categories called terminal interference and network interference.

Terminal Interference

For terminal interference, we suppose that terminals in the basic cooperative system (i.e., source, relay, and destination terminals) are interfered by a non-cooperative transmission between two terminals. Three scenarios of 5-terminal networks (see Fig.5.4.1.1) are simulated. Each scenario provides different types of interferences depending on how the terminal (s) is (are) interfered.

- In Fig.5.4.1.1a, a scenario in which only the relay terminal (R) is interfered by an A-B transmission pair is presented. Assume that the channel between A and B is perfect
- A scenario that all cooperative participating terminals (S, R, and D) are interfered is illustrated in Fig.5.4.1.1b and
- A 5-terminal network, where only R is not interfered is shown in Fig.5.4.1.1c

Note that there are two areas; i.e., transmission area and interference area (see Fig.5.4.1.1d). Terminals located in the interference area cannot correctly decode received signals but they are interfered.

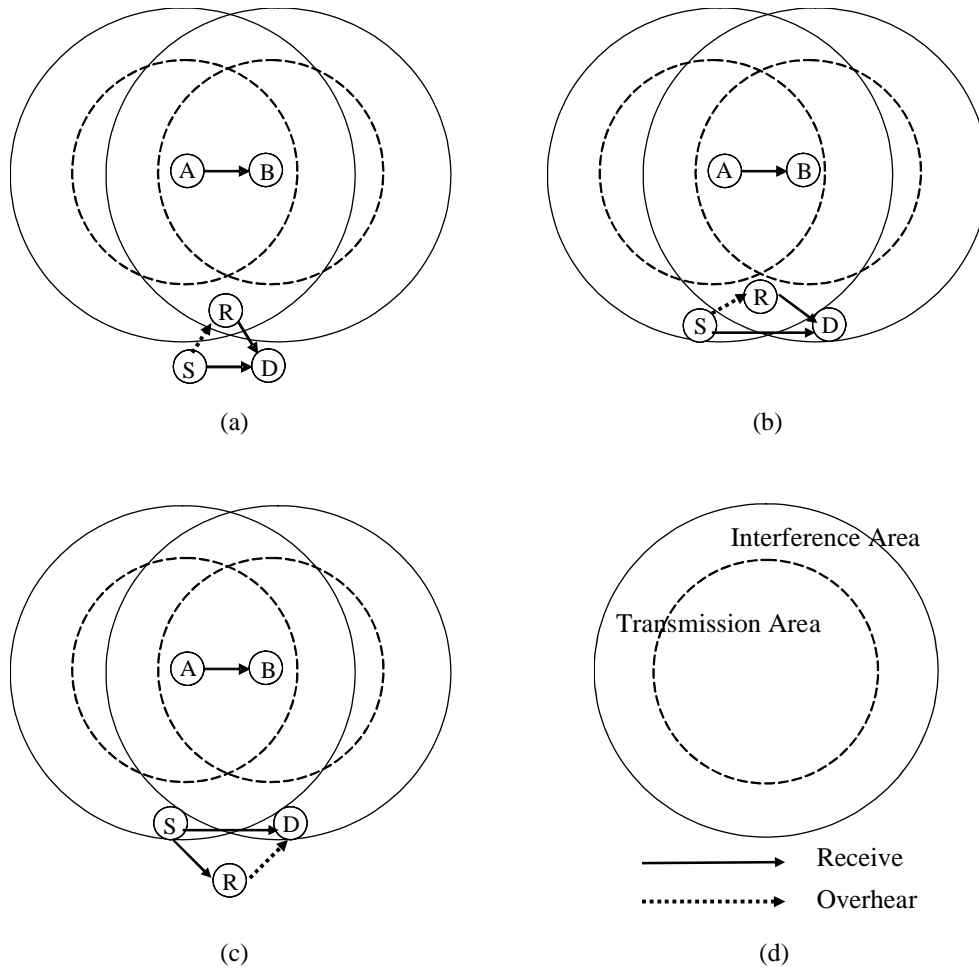

Figure 5.4.1.1: Three scenarios of 5-terminal networks.

Network Interference

For network interference, we suppose that terminals in a cooperative system interfere each other. A scenario of 9-terminal networks (as shown in Fig.5.4.1.2 and Fig. 5.4.1.3) and two scenarios of 8-terminal networks (see Fig. 5.4.1.4 and Fig. 5.4.1.5) are simulated.

The objective of the 9-terminal network is to confirm the impacts of channel availability to the ProxyCoop performance and the objective of the 8-terminal network is to study the impact of channel availability and relay choosing in ProxyCoop transmissions when a relay terminal has to relay data for a single or multiple transmission pairs.

In Fig.5.4.1.2, a 9-terminal network is illustrated. For performance comparisons, a non-cooperative communication as shown in Fig.5.4.1.3a will be compared with a proxy cooperative transmission as shown in Fig.5.4.1.3b.

In the 9-terminal network, it includes every interference scenario, which is presented in the 5-terminal networks. There are three cooperative transmission pairs; i.e. S1 to D1, S2 to D2, and S3 to D3 with one relay terminal (i.e., R1, R2, and R3) for each transmission pair. The first cooperative transmission pair (i.e., S1, R1, and D1) represents the first interference scenario of the 5-terminal networks presented in Fig. 5.4.1.1a. Terminal R1 has higher interference impact than S1 and D1. The second scenario of the 5-terminal networks (see Fig. 5.4.1.1b), which every terminal in cooperative networks having the same impact of interference, is represented by the second cooperative transmission pairs in the 9-terminal network. Finally, the third cooperative transmission pair in the 9-terminal network represents the third interference scenarios of the 5-terminal networks that are presented in Fig. 5.4.1.1c. Terminal R3 has the least interference impacts compared to S3 and D3.

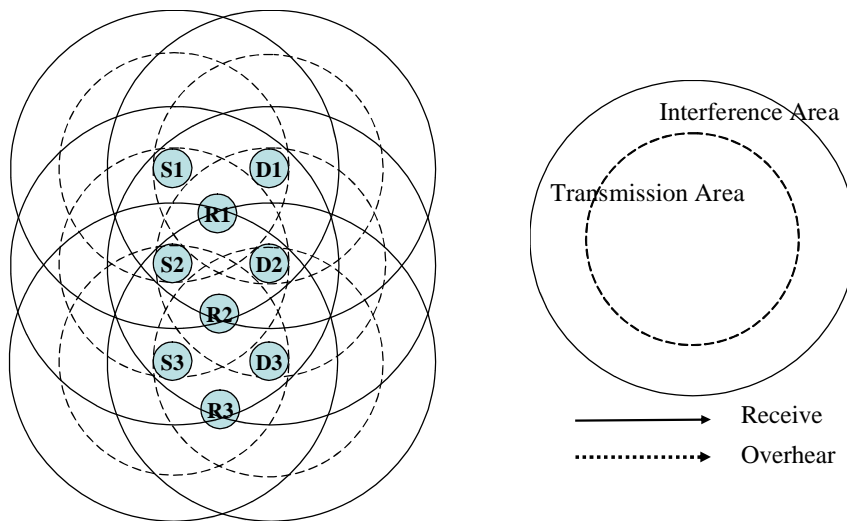

Figure 5.4.1.2: A 9-terminal network.

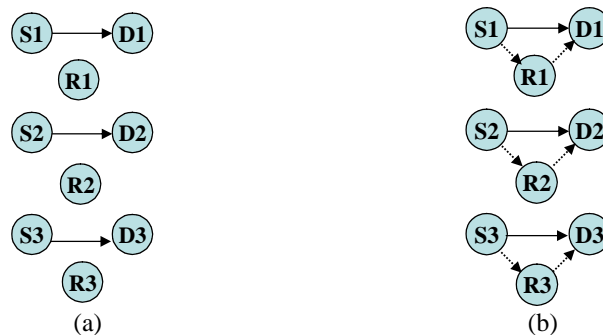

Figure 5.4.1.3: Data transmissions in the 9-terminal network (a) Non-cooperative transmissions and (b) Proxy cooperative transmissions.

In Fig.5.4.1.4, an 8-terminal network is illustrated. For performance comparisons, a non-cooperative communication as shown in Fig.5.4.1.5a will be compared with two type of proxy cooperation as shown in Fig.5.4.1.5b and Fig.5.4.1.5c.

In Fig.5.4.1.5a, there are three non-cooperative transmission pairs; i.e. S1 to D1, S2 to D2, and S3 to D3. R1 and R2 are intermediate terminals. Fig. 5.4.1.5b represents ProxyCoop Type1. There are two proxy cooperative transmission pairs (the first one is S1, R1, and D1 and the second one is S2, R2, and D2) and a non-cooperative transmissions pair (S3 to D3). Fig. 5.4.1.5c illustrates ProxyCoop Type2. There are three proxy cooperative transmission pairs. R1 is a relay terminal for a transmission pair (i.e., S1 to D1) while R2 is a relay terminal for two transmission pairs (i.e., S2 to D2 and S3 to D3).

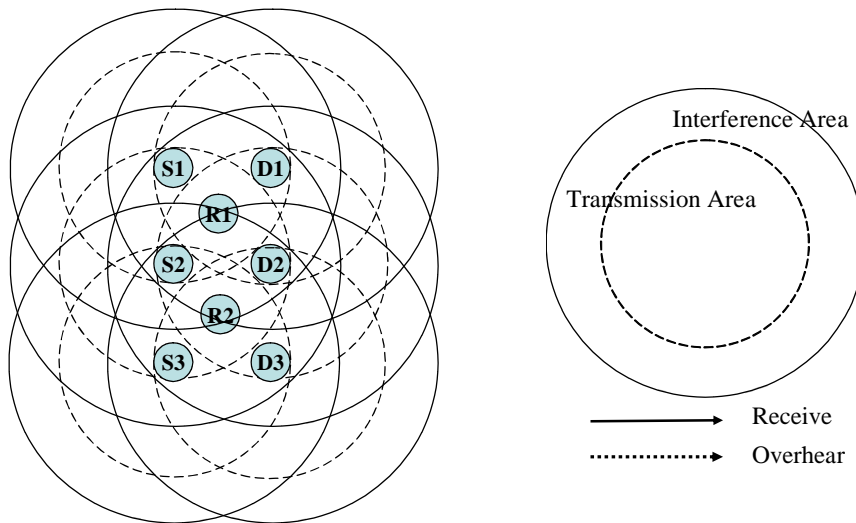

Figure 5.4.1.4: A 8-terminal network.

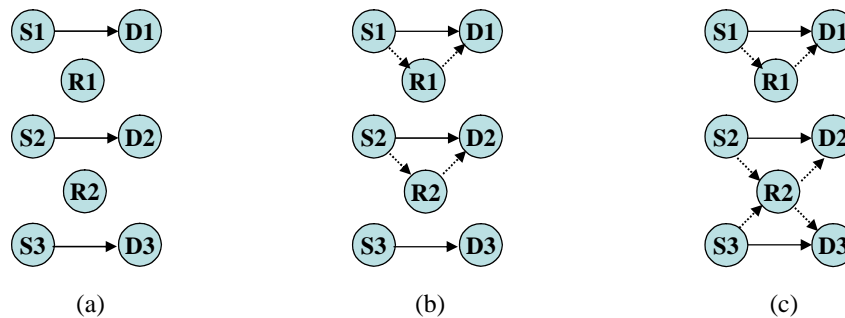

Figure 5.4.1.5: Data transmissions in the 8-terminal network (a) Non-cooperative transmission (b) ProxyCoop Type1 (c) ProxyCoop Type2.

5.4.2. System Model

To evaluate the impacts of the channel availability, various scenarios of interference as described previously are simulated by NS 2.30 simulator [NeSi10]. To generate the impacts of channel quality, error probabilities in each direct path (S_i to D_i) and multi-hop path (S_i to R_i and R_i to D_i) are varied. Similar to the 3-terminal network, the frame error probabilities of the direct path (P1) are set at 0.1 and 0.2 per frame, while those of the proxy paths (P2) are varied from 0.025 to 0.4 per frame. For physical channels, the two-ray ground propagation model is used, while IEEE 802.11 [IEEE07] and AODV [PeRD03] are used as the MAC, and the routing protocols. The UDP agents are created to send CBR traffic with data rate 448kbps and packet size equals to 210 bytes. The simulation time for the 5-terminal networks is 300 seconds and 500 seconds for the 9-terminal network and the 8-terminal network.

The performance evaluation is done with two metrics. Firstly, the transmission performance is evaluated in terms of PDR. Secondly, the administrative (routing) performance is evaluated in terms of the NRDM per second. The PDR and NRDM per second are calculated only from terminals in cooperative network (i.e., terminal S, R, and D of the 5-terminal network and terminal S_i , R_i , and D_i of the 9-terminal network). The PDR and NRDM per second of the transmission pair from A to B will not be considered.

5.4.3 Simulation Results and Analysis

In the first scenario of the 5-terminal networks, where only the terminal R is interfered by the A-B transmission pair, there is no multi-hop transmission mode transition in both of non-cooperative and ProxyCoop transmissions when $P1=0.1$ and 0.2 ; thus, the percentages of data frames sent in multi-hop mode equal to zero as shown in Fig.5.4.3.1. The x-axis represents values of P1 over P2 ($P1/P2$).

The PDRs for the first scenario of the 5-terminal networks with non-cooperative and ProxyCoop transmission in different link quality configurations are shown in Fig.5.4.3.2. The PDRs of ProxyCoop are less than those of the non-cooperative transmission because of the impact of the extended timeout in ProxyCoop and hidden terminal problems.

In the first scenario of the 5-terminal networks, terminal S and D are hidden from terminal A and B. Terminal R has to compete with terminal A and B to acquire the medium. In addition, since we assume that the channel quality between terminal A and B is perfect, it is very difficult that R can acquire the medium for data relaying. In ProxyCoop, terminal D received most of the data from terminal S; thus, the PDRs of ProxyCoop are nearly constant. In addition, when, R cannot relay data to D efficiently, S in ProxyCoop has to re-transmit the data with the extended timeout, which causes longer delay comparing to the re-transmission processes in non-cooperative transmissions. Therefore, the PDRs of ProxyCoop are less than those of the non-cooperative transmission.

From simulation results, we can conclude that if there is no multi-hop transmission mode transition in non-cooperative transmissions and the relay terminal has problems on channel availability, ProxyCoop should remain its transmission mode in the direct transmission mode. Proxy cooperative transmission mode should be turned off.

For the non-cooperative transmission, its PDRs are nearly constant because all data are sent in the direct mode; thus, the performance of the system is only function of P1, which is constant. The increasing of P2 does not affect the performance.

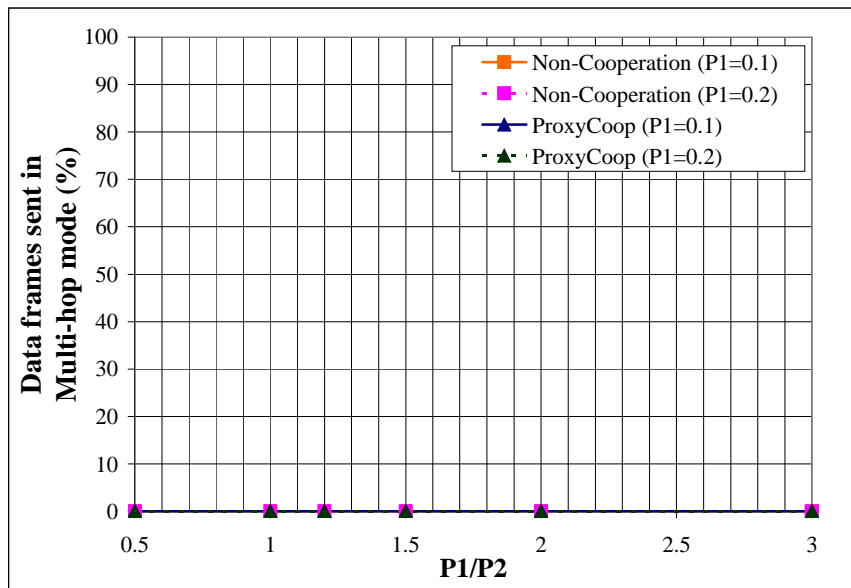

Figure 5.4.3.1: The percentage of data frames sent in multi-hop mode in scenario 1.

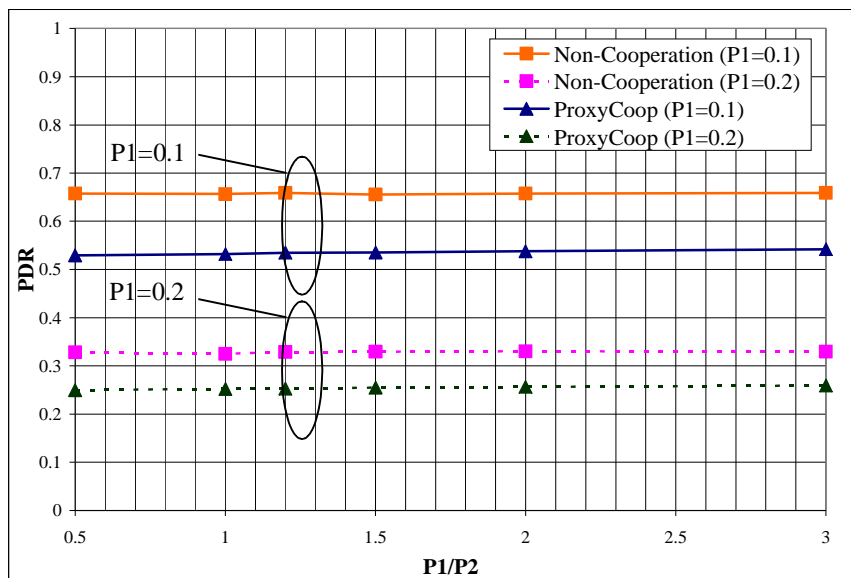

Figure 5.4.3.2: PDR of non-cooperative and ProxyCoop transmissions in scenario 1.

In the second scenario of the 5-terminal networks, where all terminals are interfered by the A-B transmission pair, multi-hop transmission state transitions occur in both of non-cooperative and ProxyCoop transmissions (see Fig.5.4.3.3). However, the percentage of data frames in ProxyCoop that are sent in multi-hop mode is less compared with that of non-cooperative transmission. The result confirms that our proposition can alleviate probabilities of multi-hop transmission mode transitions.

In Fig.5.4.3.4, ProxyCoop generally has higher PDRs than those of the non-cooperative transmission. Thus, we can conclude that ProxyCoop is interesting when every terminal has same condition of channel availability and there are chances of transmission mode transition in non-cooperative transmission to transit from direct mode to multi-hop mode.

More precisely, on the left-hand side of Fig.5.4.3.4 when $P1=0.2$, the PDR of ProxyCoop is lower than that of non-cooperative transmission because channel qualities of the multi-hop paths are very poor. This problem leads to two major drawbacks. First, when R missed-hears ACK packets, it competes with S to transmit data; thus, the collisions are occurred. Second, R is not able to help S on data relaying because it is unable to decode the data frame sent from S; therefore, D has to wait for the re-transmission done by S after the extended timeout, which is about twice longer than the one of the non-cooperative technique.

Focus on the non-cooperative transmission, when channel qualities of the proxy paths are increased, the percentage of data sent in multi-hop transmission mode and the PDR of the non-cooperative transmission are increased. Thus, we can conclude that when terminals have problems with channel availability, high reliable multi-hop transmissions provide better performance than direct transmission through a channel with poor channel quality.

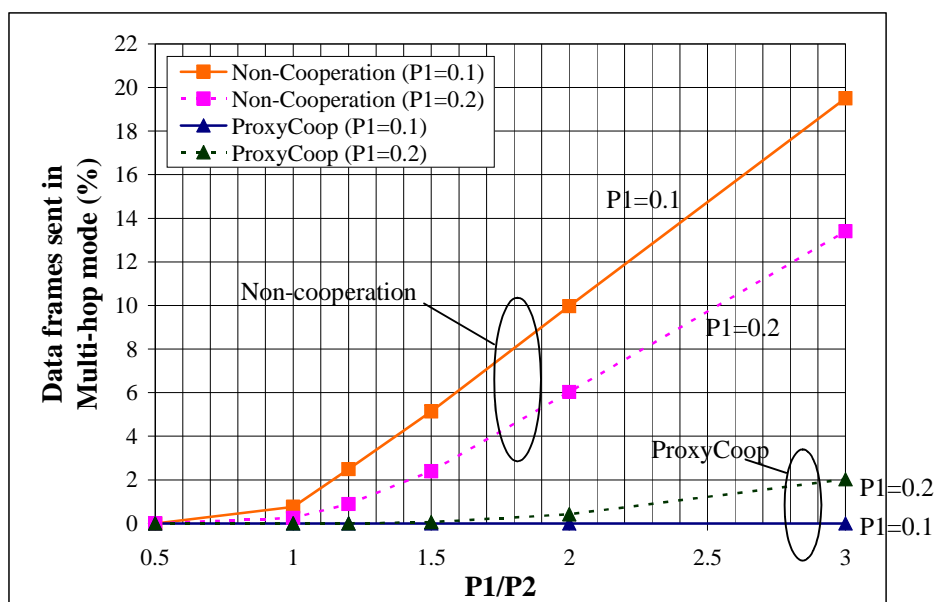

Figure 5.4.3.3: The percentage of data frames sent in multi-hop mode in scenario 2.

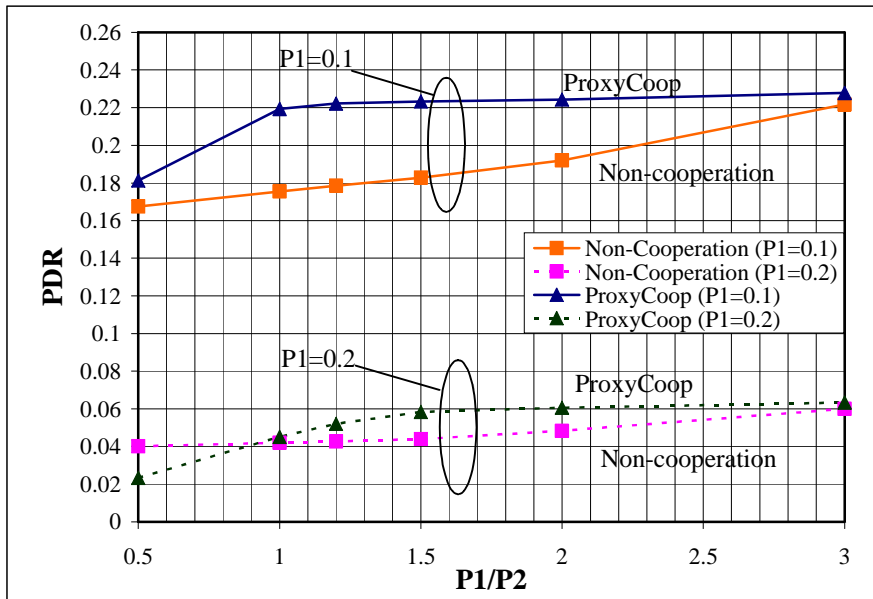

Figure 5.4.3.4: PDR of non-cooperative and ProxyCoop transmissions in scenario 2.

In the third scenario of the 5-terminal networks, where only the terminal R is not interfered by the A-B transmission pair, transmission state transitions occur in non-cooperative transmission but not in ProxyCoop. The percentage of data frames in ProxyCoop that are sent in multi-hop mode equals to zero while non-cooperative transmission has high percentage of data frames sent in multi-hop mode, as shown in Fig.5.4.3.5. Thus, probabilities of multi-hop transmission mode transitions are alleviated.

Similar to the second case, ProxyCoop is interesting when there are chances of multi-hop transmission mode transitions. Since R is not interfered by the A-B transmission pair, it can well perform on data relaying. Therefore, ProxyCoop has higher PDR compared to the non-cooperative transmission as shown in Fig.5.4.3.6 when $P1 = 0.1$.

However, on the right-hand side of Fig.5.4.3.6 when $P1 = 0.2$ and multi-hop paths have very high channel quality and channel availability, ProxyCoop yields lower PDR than that of the non-cooperative transmission because the terminal D in ProxyCoop has to reply ACK frames through the direct path (with $P1 = 0.2$ and low channel availability) while the non-cooperative transmission works in multi-hop mode and its ACK frames are sent through the multi-hop paths (with $P2 < 0.1$ and high channel availability).

In the third scenario of the 5-terminal networks, we can conclude that ProxyCoop is interesting when terminal R has good condition on channel quality and channel availability, and there are probabilities of multi-hop transmission mode transition in non-cooperative transmission. However, if the channel quality and channel availability of the

multi-hop paths are much higher than that of the direct path, ProxyCoop should switch its transmission mode from direct mode and proxy cooperative mode to multi-hop mode.

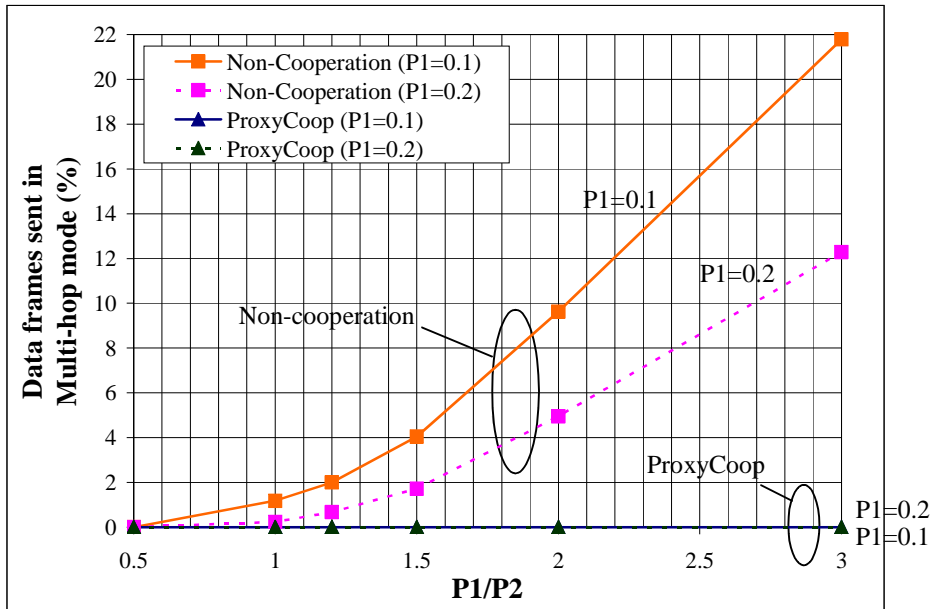

Figure 5.4.3.5: The percentage of data frames sent in multi-hop mode in scenario 3.

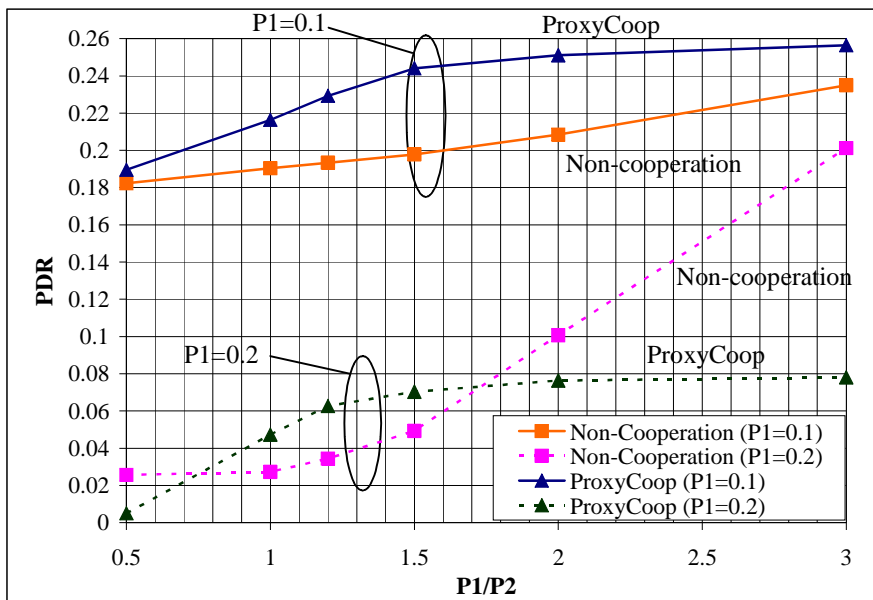

Figure 5.4.3.6: PDR of non-cooperative and ProxyCoop transmissions in scenario 3.

Conclusion of the 5-terminal networks

From the evaluation of the impact of channel quality and channel availability to the performance of ProxyCoop in the 5-terminal networks, we can conclude the interest of ProxyCoop as follows.

- For the impact of channel quality, ProxyCoop is interest when the channel quality of the proxy paths is higher than that of the direct path and there are probabilities of multi-hop transmission mode transitions.
- For the impacts of channel availability, as shown in the first case of the 5-terminal network, if the relay terminal has higher interference effect than the source and the destination terminals, it means that terminals interfering the relay terminal are hidden from the source and the destination terminals. Thus, ProxyCoop should turn off its proxy transmission mode.
- From the third case of the 5-terminal network, when the relay terminal has very less interference effect than the source and the destination terminals and its channel quality of the proxy path is much higher than that of the direct path, ProxyCoop should switch its transmission mode to multi-hop mode.

In the 9-terminal network, the x-axis of Fig.5.4.3.7 and Fig.5.4.3.8 represents values of P1 over P2 (P1/P2). Similar to previous simulations, the P1 is set at 0.1 and 0.2 per frame and P2 is varied from 0.025 to 0.4 per frame. Multi-hop transmission mode transitions occur in both of non-cooperative and ProxyCoop transmissions. However, the percentage of data frames in ProxyCoop that are sent in multi-hop mode is very less compared with non-cooperative transmission (see Fig.5.4.3.7). Thus, the probabilities of multi-hop transmission mode transitions are also alleviated in the 9-terminal network.

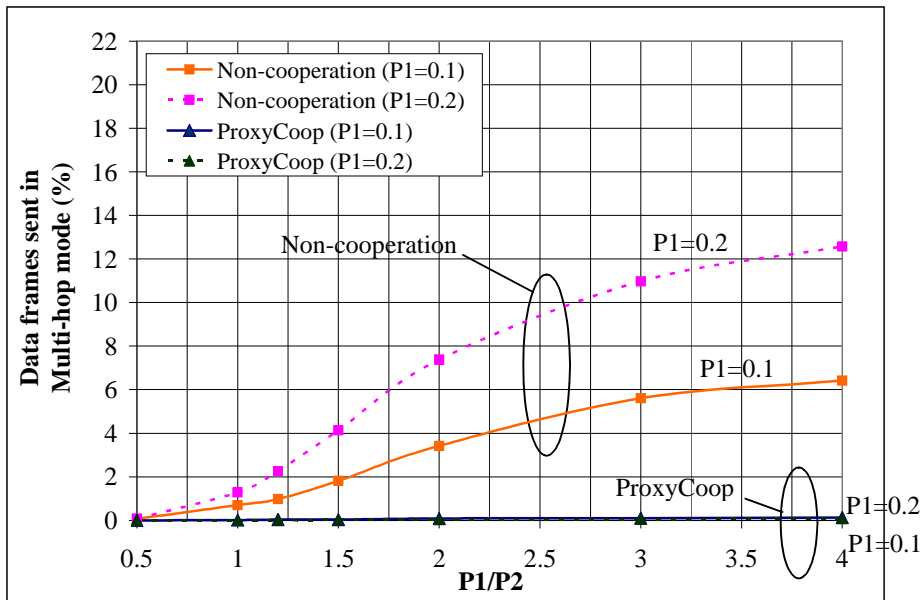

Figure 5.4.3.7: The percentage of data frames sent in multi-hop mode in the 9-terminal network.

In Fig.5.4.3.8, on the left-hand side, when the link qualities of the proxy paths are worse than those of the direct paths, the PDR of ProxyCoop is lower than those of the non-cooperative transmissions because of the collisions when R_i missed-hears ACK packets and the extended re-transmission time introduced by the inefficient relay transmissions. Nevertheless, when the link qualities of the proxy paths are increased, the PDRs of ProxyCoop are continually increased. In some ranges of $P1/P2$, the ProxyCoop provides higher PDRs than those of the non-cooperative transmissions.

For non-cooperative transmissions, when the link qualities of the proxy paths are increased, its PDRs are decreased due to multi-hop transmission delays. However, when multi-hop paths have very high channel qualities compared to the direct path, transmissions through multi-hop paths are more interesting than re-transmissions through the direct paths with low channel qualities. Thus, on the right-hand side of Fig.5.4.2.8, the PDRs of non-cooperative transmissions are increased. The increment of the PDR is mainly affected by the multi-hop transmission through terminal R3, which has the highest channel availability (least interference) compared with R1 and R2.

In addition, similar to the third scenario of the 5-terminal networks, on the right-hand side of Fig.2.4.2.8 when $P1=0.2$ and multi-hop paths have very high channel qualities, the non-cooperative transmission has its PDR very close to that of the ProxyCoop transmission because the terminal D_i in ProxyCoop has to reply ACK frames through the direct path with $P1=0.2$ while the non-cooperative transmission works in multi-hop mode and its ACK frames are sent through the multi-hop paths with $P2 < 0.053$.

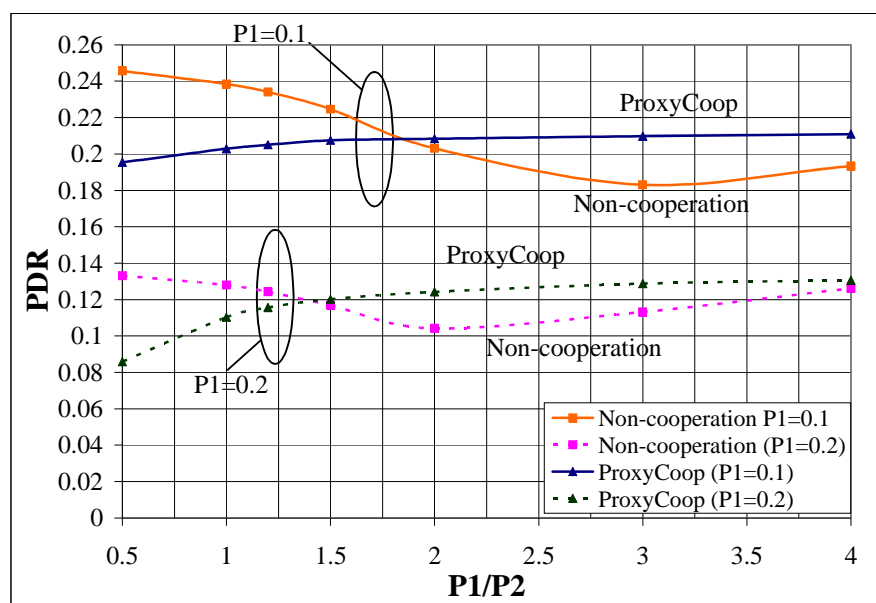

Figure 5.4.3.8: PDR of non-cooperative and ProxyCoop transmissions in the 9-terminal network.

Conclusion of the 9-terminal network

From the evaluation of the impact of channel quality and channel availability to the performance of ProxyCoop in the 9-terminal network, it confirms our conclusion on the interest of ProxyCoop that we have done for the 5-terminal network. The interest of ProxyCoop can be concluded as follows.

- As previous conclusions, ProxyCoop is interest when there are probabilities of multi-hop transmission mode transitions and the channel quality of the proxy paths is higher than that of the direct path.
- If the channel quality of the proxy paths is lower than that of the direct path, ProxyCoop should turn off its proxy transmission mode.
- If there are any relay terminals have very less interference effect compared with their source and their destination terminals, and their channel quality of the proxy path is much higher than that of the direct path, ProxyCoop may have to switch the transmission mode of those transmission pair to multi-hop mode.

In the 8-terminal network, since the objective is to study the impacts of channel availability and relay choosing in ProxyCoop transmissions when a relay terminal has to relay data for a single or multiple transmission pairs, a non-cooperative communication will be compared with two type of proxy cooperation as shown in Fig.5.4.1.5. Similar to the 9-terminal network, the x-axis the x-axis of Fig.5.4.3.9 and Fig.5.4.3.10 represents values of P1 over P2 ($P1/P2$). P1 is set at 0.1 and 0.2 per frame and P2 is varied from 0.025 to 0.4 per frame.

Multi-hop transmission mode transitions occur in both of non-cooperative and ProxyCoop transmissions. However, the percentage of data frames in ProxyCoop that are sent in multi-hop mode is less than that of the non-cooperative transmission (see Fig.5.4.3.9). Thus, ProxyCoop can alleviate the probabilities of multi-hop transmission mode transitions.

Comparing the percentages of the data sent in multi-hop mode between ProxyCoop Type1 and Type 2, when P1 equal to 0.1 and 0.2, we found that the percentages of the data sent in multi-hop mode in ProxyCoop Type1 are higher than those of ProxyCoop Type 2 because the third transmission pair of the ProxyCoop Type1 (i.e., S3 and D3) is a non-cooperative transmission pair. It changes its transmissions mode to multi-hop transmission when the channel quality of the proxy path is higher than the direct path.

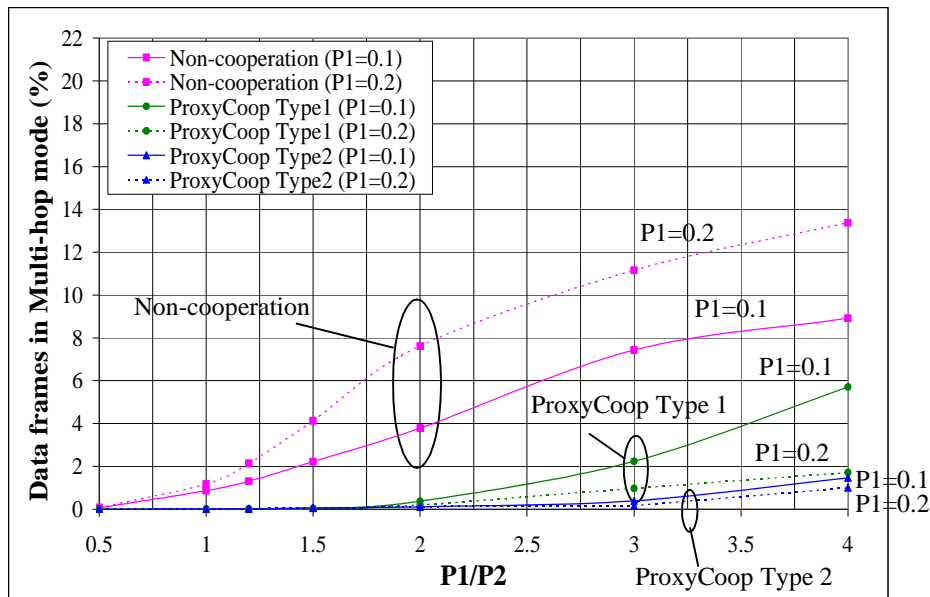

Figure 5.4.3.9: The percentage of data frames sent in multi-hop mode in the 8-terminal network.

As mentioned in the 9-terminal network, on the left-hand side of Fig.5.4.3.10, when the link qualities of the proxy paths are worse than those of the direct paths, the PDR of the non-cooperative transmission is higher than those of the two types of ProxyCoop because ProxyCoop functions cannot work properly. Relay terminals generate collisions when they missed-hears ACK packets (i.e., R_i competes with S_i on data transmissions) and destination terminals have to wait for the re-transmission done by source terminals with the extended timeout because relay terminals are unable to decode their received data frames. Since ProxyCoop Type1 has two pairs of cooperative transmission (while ProxyCoop Type2 has three pairs), it has less effects from the inefficient data relaying. Therefore, the PDR of ProxyCoop Type1 is higher than that of ProxyCoop Type2.

However, on the right-hand side of Fig.5.4.3.10, when the link qualities of the proxy paths are higher than those of the direct paths, the non-cooperative transmission switches its transmission mode to multi-hop mode. Thus, the PDR of the non-cooperative transmission is lower than those of the two types of ProxyCoop because of the multi-hop delay.

Focus on the PDRs of ProxyCoop Type1 and Type2, the PDRs are decreased when there are probabilities of multi-hop transmission mode transitions. Since ProxyCoop Type1 has a non-cooperative transmission, it has higher probabilities of multi-hop mode transitions than ProxyCoop Type2. Thus, the PDR of ProxyCoop Type1 is more decreased than that of ProxyCoop Type2.

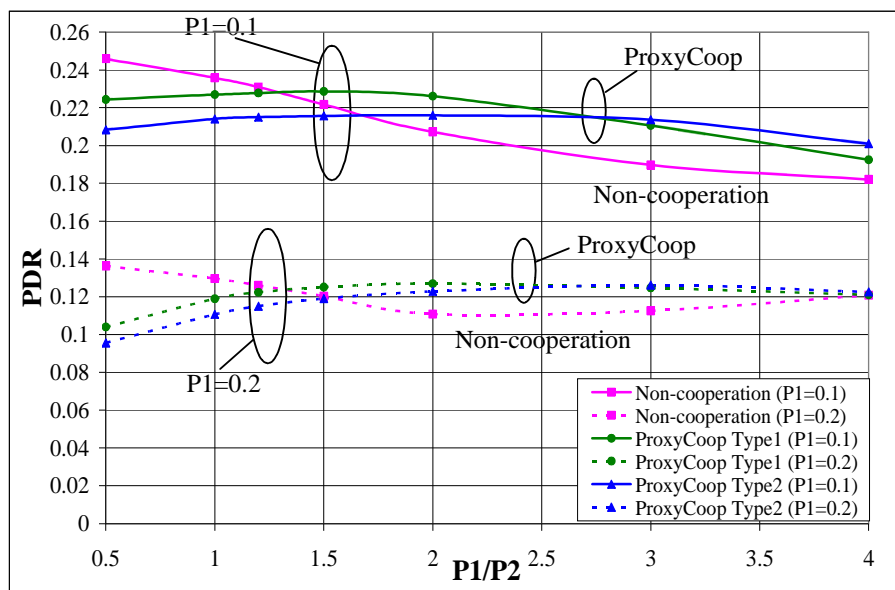

Figure 5.4.3.10: PDR of non-cooperative and ProxyCoop transmissions in the 8-terminal network.

Conclusion of the 8-terminal network

From the evaluation of the impacts of channel availability and relay choosing in ProxyCoop transmissions, we can conclude that, in contention networks, there are probabilities of multi-hop transmission mode transitions and the channel quality of the proxy paths is higher than that of the direct path, ProxyCoop transmissions are more interesting than non cooperative transmissions.

5.4.4. Conclusion

In this part, impacts of channel quality and channel availability to the ProxyCoop transmission performance have been studied. Beyond the proposition, the interest of this experiment concerns the study of the proposition validity that leads to determine some adaptation rules. From simulation results, it confirms that ProxyCoop transmission must be adaptable. The transmission performance of ProxyCoop transmission (evaluated by PDR) outperforms that of non-cooperative transmissions when channel distributions of the direct path can cause multi-hop mode transitions in non-cooperative transmissions and a good relay is selected. A good relay means a relay terminal located in transmission ranges of the source and the destination terminal. In addition, its cooperative multi-hop paths must have high channel quality and high channel availability than the direct path.

Therefore, rather than to select a relay terminal based only on the channel quality (usually done by measuring the signal strength or the SNR of received signals) as proposed in other cooperative communications, we recommend that the control protocol in charge of relay selection (AODV routing protocol for Ad Hoc networks or HWMP for wireless

mesh networks, for examples) has to collect information on both of channel qualities and channel availability of each potential relay terminal. For instance, information of channel availability can be done by measuring the number of frames that are overheard by each potential relay terminal.

5.5 CONCLUSION

In this chapter, a design of cooperative transmission part in cooperative communications has been done. A new adaptive cooperative transmission named Proxy Cooperative Transmission (ProxyCoop) that can work compatibly with the legacy systems and is compatible with both of the basic and the optional access methods of the IEEE 802.11 MAC protocol has been proposed.

To improve the performance of ProxyCoop transmission, its transmission mode must be adaptable. Transmission mode selection must be done based on the absence of ACK frames, the probability of multi-hop transmission mode transitions, channel quality, and channel availability. In addition, we suggest that, in contrast to other cooperative communications that their relay selections are usually done based only on the channel quality, the channel availability must also be concerned.

In the next chapter, in order to complete our cooperative communication design, based on cooperative network model, the designs of cooperative setups in term of Cooperative mode activation, Cooperation data acquisition, Relay selection, and Relay notification will be explained.

Chapter 6

PROXY COOPERATIVE SETUP:

(A PROPOSITION ON COOPERATIVE SETUP DESIGN)

Contents

- 6.1. ProxyCoopSetup Designs
 - 6.1.1. Cooperative mode activations
 - 6.1.2. CoI acquisitions
 - 6.1.3. Relay selection methods
 - 6.1.4. Cooperative mode notifications
 - 6.2. ProxyCoopSetup Performance
 - 6.2.1. System model and simulation parameters
 - 6.2.2. Simulation results and analysis
 - 6.3. Proxy cooperative communications in IEEE 502.11s WLAN mesh networks
 - 6.4. Conclusion
-

This chapter presents a proposition on cooperative setup method named “*Proxy Cooperative Setup (ProxyCoopSetup)*”. The proposition is done in the network layer and it relies on the AODV routing protocol [PeRD03]. The RREQ/RREP cycle of the AODV routing protocol is applied to work for the four main cooperative functions in the control plane of the cooperative network model; i.e. cooperative mode activations, CoI acquisitions, relay selections, and cooperative mode notifications.

The interest of the proposition is to fulfill ProxyCoop communications in part of cooperative setup. Moreover, the proposition is based on an existing Internet Engineering Task Force (IETF) standard protocol, AODV, so that it could be easily deployed.

The costs of ProxyCoopSetup when it works with ProxyCoop transmissions will be studied by comparing the PDR and the NRDM per second of ProxyCoop transmissions with and without ProxyCoopSetup.

Chapter Organization

In the first part, details of ProxyCoopSetup designs are presented. The design is done based on the cooperative network model.

Then, ProxyCoopSetup is implemented in ProxyCoop transmissions in order to study the costs of ProxyCoopSetup to ProxyCoop transmissions. The evaluation will be done by simulations. The objective is to compare the performance of ProxyCoop transmissions with and without ProxyCoopSetup in terms of PDR and NRDM per second.

Finally, the implementation of the proxy cooperative communication and how it can be integrated on existing networks will be considered. WLAN Mesh Networks (WMNs) is chosen as an example of existing networks that can support the proposition. In this part, we will show how to apply Proxy cooperative communications (in both of ProxyCoop transmission and ProxyCoopSetup) into WMNs.

6.1. PROXYCOOPSETUP DESIGNS

Cooperative setup in the network layer

In order to take advantage of the ProxyCoop transmission method that it can work compatibly with both of the basic access method and the optional access method of IEEE 802.11, ProxyCoopSetup are designed to be operated in the network layer. Thus, it is not dependent on the underlying protocols. More precisely, the proposed method can work regardless to the access methods of the MAC layer.

ProxyCoopSetup has been designed based on the AODV routing protocol, in order to obtain a system that quite compatible with existing systems, its routing discovery method can be implemented on the *relay discovery processes* in ProxyCoopSetup method. In addition, an address resolution protocol (ARP) that is used by the AODV allows relay terminals to acquire the MAC address of the source-destination pair that it has to help on data relaying. These addresses are used by the relay terminal for data filtering and data forwarding processes. Details of AODV routing protocol and ARP are as follows.

AODV routing protocol

AODV [PeRD03] is a well known routing protocol standardised by the IETF for Mobile Ad hoc Network (MANET). It is an on-demand routing protocol meaning that it builds routes between terminals only when a source terminal requires a data transmission route to a destination terminal. The routes are maintained as long as they are needed by the sources. AODV builds routes by using a “*RREQ/RREP cycle*”. When a source terminal desires a route to a destination for which it does not already have a route, it broadcasts a RREQ packet across the network, as shown in Fig.6.1.1.

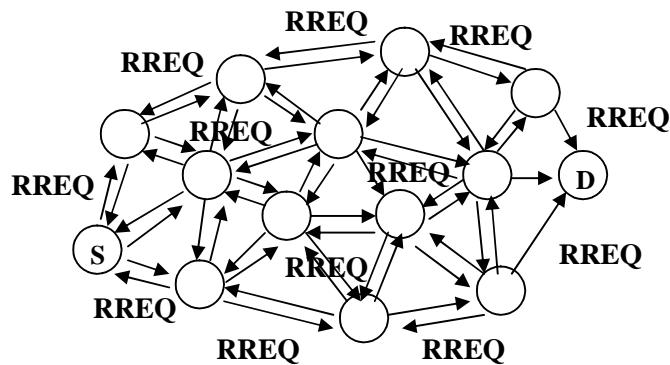

Figure 6.1.1: RREQ broadcasting.

Terminals receiving this packet update their information for the source terminal and set up backwards pointers to the source terminal in their “*routing tables*”. In addition to the source terminal's IP address, current sequence number, and broadcast ID, the RREQ

packet also contains the most recent sequence number for the destination, which the source terminal is aware of.

A terminal receiving the RREQ packet may unicastly send a RREP packet back to the source terminal if it is either the destination terminal or if it has a route to the destination terminal with corresponding sequence number greater than or equal to that contained in the RREQ packet. Otherwise, it rebroadcasts the RREQ packet. However, note that, by keeping track of the RREQ's source IP address and broadcast ID, if terminals receive a RREQ which they have already processed, the RREQ packet will be discarded and will not be broadcasted.

Fig.6.1.2 shows how the destination terminal replies the RREP packet back to the source terminal. The RREP packets are unicastly sent back from the destination terminal (or next-hop terminal) to its previous-hop terminal. The RREQ packet will be forwarded until it reaches the source terminal. In Fig.6.1.2, terminal S is the previous-hop of terminal I1, while terminal I1 is the previous-hop of terminal I2, for examples. In contrast, terminal I1 is the next-hop terminal of terminal S, while terminal I2 is the next-hop terminal of terminal I1.

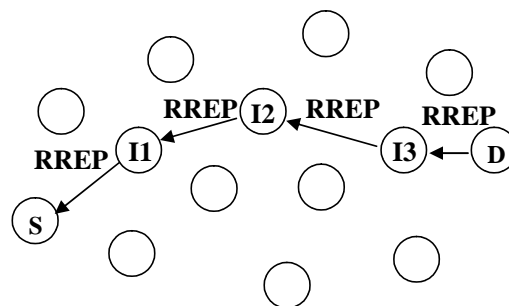

Figure 6.1.2: RREP process.

Once the source terminal receives the RREP, it begins to transmit its data packets to the destination terminal. If the source terminal later receives a RREP containing a greater sequence number or contains the same sequence number with a smaller hopcount, it updates its routing information for that destination and begins to use the better route.

Address resolution Protocol (ARP)

ARP [Plum98] is a protocol which is used to translate protocol addresses in the network layer (typically called an Internet Protocol (IP) address) to MAC address. It is located at the interface between the network layer (layer 3 of OSI model) and the MAC layer (layer 2 of OSI model).

In AODV routing protocol, since the RREP packets are unicastly sent back to the source terminal, the destination terminal (or next-hop terminal) requires the MAC address of its previous-hop terminal. The MAC address of each previous-hop terminal can be acquired by ARP processes.

As shown in Fig.6.1.3, *ARP request packets* are sent on broadcasted frames in order to ask for the MAC address. In the ARP request packets, there are an IP address of the current terminal, which is the originator of the ARP request packet, a MAC address of the current terminal, an IP address of the target terminal, which is the previous-hop terminal of the current terminal, and a MAC address of the target terminal. However, since the MAC address of the target terminal is unknown, 00:00:00:00:00:00 is put in this field.

ARP request packets allow the target terminal to get the MAC address of the originator terminal of the ARP request packet. Thus, after receiving the ARP request packet, the target terminal unicastly sends an *ARP reply packet* containing its MAC address to the originator terminal of the ARP request packet. After receiving the MAC address of the target terminal from the ARP reply packet, the current terminal can unicastly transmit its RREP packet to its previous-hop terminal.

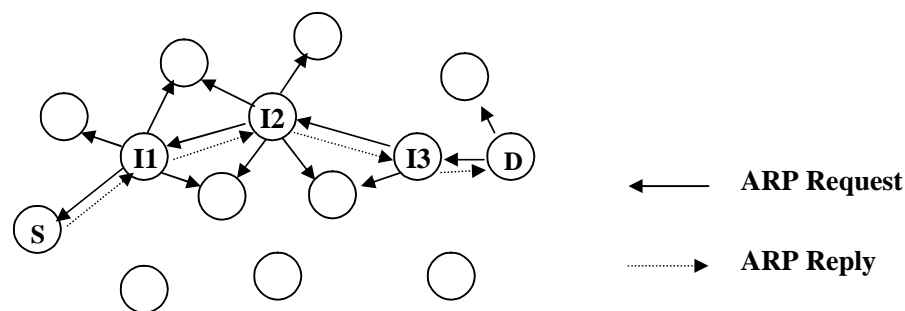

Figure 6.1.3: ARP process.

Cooperative setup of ProxyCoopSetup is done in each transmission hop

For simplicity, instead of setting a cooperative network for an entire route from a source terminal to a destination terminal as proposed in [GuDC09], the cooperative setup of ProxyCoopSetup is designed to be done independently in each transmission hop along the route from a source terminal to a destination terminal. In addition, this proposition provides benefit on resource efficiency since cooperative communications are only used in transmission hops, which have problems on data transmissions.

However, since ProxyCoopSetup can be independently processed in each transmission hop, a terminal which is the originator of ProxyCoopSetup can be a source terminal or any intermediate terminals, and the destination terminal of ProxyCoopSetup can be a destination terminal of the data transmission or a next-hop terminal of the ProxyCoopSetup originating terminal.

To ease the presentation and avoid an ambiguous understanding, we focus on a simple example network constituted with five terminals as shown in Fig.6.1.4. In the figure, S, P, R, N, and D respectively stand for source, previous-hop, relay, next-hop, and destination terminals. The data are sent from source to destination terminals through terminal P and N. We assume that a cooperative setup is required in the transmission hop between terminal P and terminal N.

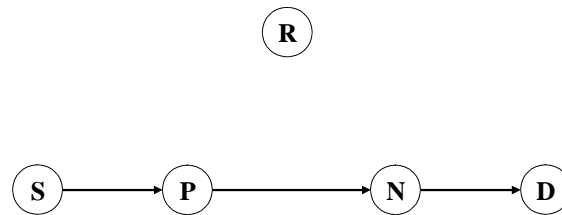

Figure 6.1.4: An example of 5-terminal network.

Cooperative setup designs based on Cooperative Network Model

For convenience and systematical design, ProxyCoopSetup has been designed based on the cooperative network model. ProxyCoopSetup design concerns four functions in the control plane of the model, i.e. Cooperative mode activations, CoI acquisitions, Relay selections, and Cooperative mode notifications. These four functions have been mapped into the route discovery process of the AODV routing protocol through the example network composed of five terminals as shown in Fig.6.1.4. The design concept of ProxyCoopSetup and how to modify the route discovery process of the AODV routing protocol to work for ProxyCoopSetup method are briefly illustrated in Fig.6.1.5.

The route discovery process of the AODV routing protocol is shown in Fig.6.1.5a. When cooperative setup is required in the transmission hop between terminal P and terminal N, ProxyCoopSetup processes its four cooperative setup functions as shown in Fig.6.1.5b and 6.1.5c.

After cooperative mode activations, *a relay request packet (ReREQ)* modified from RREQ packet is broadcasted from terminal P in order to activate its neighbour terminals to work in ProxyCoopSetup processes. In addition, the ReREQ is used for CoI acquisition purposes. The ReREQ packet carries a CoI from terminal P and every potential relay terminal to terminal N. This CoI will be used in the relay selection algorithm, which is done at terminal N.

In CoI acquisition processes, after receiving the ReREQ, if potential relay terminals can work with cooperative functions, they create *a cooperative table* to collect CoI and details of their cooperative neighbour terminals. Then, the potential relay terminals add their CoI into the ReREQ and forward it to terminal N. Terminal N collects all CoI indicated in the ReREQ sent from terminal P and every potential relay terminals to use it in the relay selection algorithm. When the best relay terminal is chosen, terminal N

notifies the chosen relay terminal and terminal P by *a relay reply packet (ReREP)* which is modified from the RREP packet. The ReREP is unicastly sent from terminal N to the chosen relay terminal R and forwarded to terminal P. When the chosen relay terminal R receives the ReREP packet, it knows that it has to help terminal P on data relaying to terminal N. The ARP processes allow terminal R to get both MAC addresses of terminal P and N; thus, terminal R can correctly filter and forward data in cooperative transmission modes. Details of ProxyCoopSetup in depth are presented as follows.

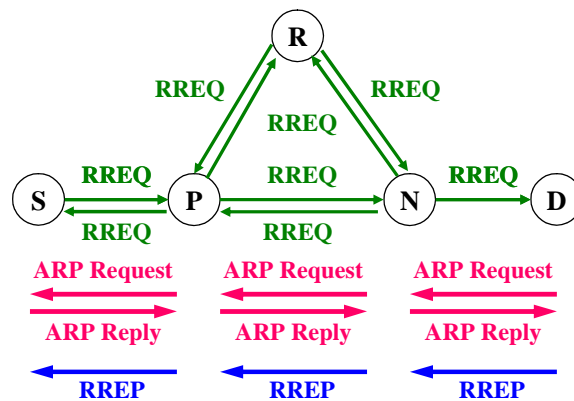

(a) AODV route discovery process.

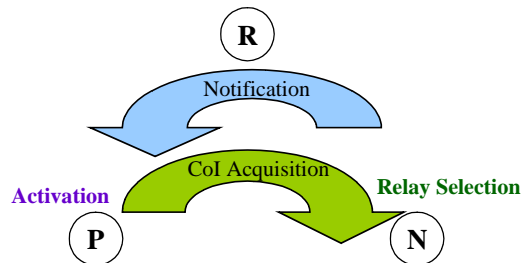

(b) Cooperative setup functions of ProxyCoopSetup.

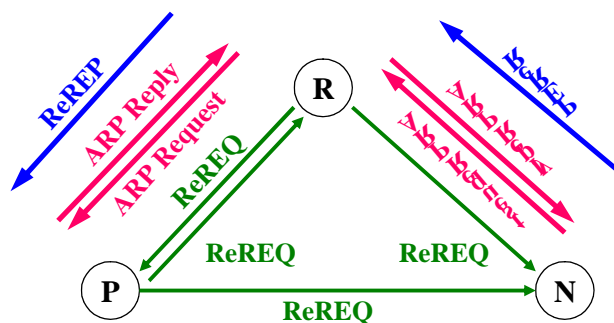

(c) ProxyCoopSetup between terminal P and N.

Figure 6.1.5: ProxyCoopSetup based on AODV routing protocol.

6.1.1. Cooperative mode activations

The objective of cooperative mode activation is to activate cooperative functions of the terminal itself and to invite other terminals to work on cooperative setup. Cooperative mode activation can be done in two different ways: proactive way or reactive way.

Similar to other cooperative setup methods, ProxyCoopSetup gains processing time and requires resource. Therefore, for resource efficiency purposes, we design ProxyCoopSetup to work in reactive mode meaning that the relay discovery process of ProxyCoopSetup is activated only when the failures in data transmissions can be detected. The data failure can be detected by the absence of ACK frames. In addition, in multi-hop networks, ProxyCoopSetup is design to be processed only in data transmission hops which have problems in data transmissions. Data transmission hops which have high channel qualities can remain to transmit regularly in non-cooperative transmission mode.

Since relay selection algorithm of ProxyCoopSetup is a per-flow process, when terminal P detects errors in data transmissions, it checks whether a relay discovery process has been done or not. If the relay discovery process has already been done, it uses the relay selection result acquired from the former relay discovery process. Thus, terminal P can switch to send its data in proxy cooperative transmission mode. Referring to details of ProxyCoop transmission presented in chapter 5, in proxy cooperative transmission mode, terminal P extends its transmission timeout and transmits its data regularly.

If the relay discovery process has never been done by terminal P, the CF1 block in the control plane of terminal P is activated through 1-b as shown in Fig.6.1.1.1.

Note that if the link of the direct path is broken and AODV route re-discovery is processed, the relay selection result acquired from the former relay discovery process will be reset.

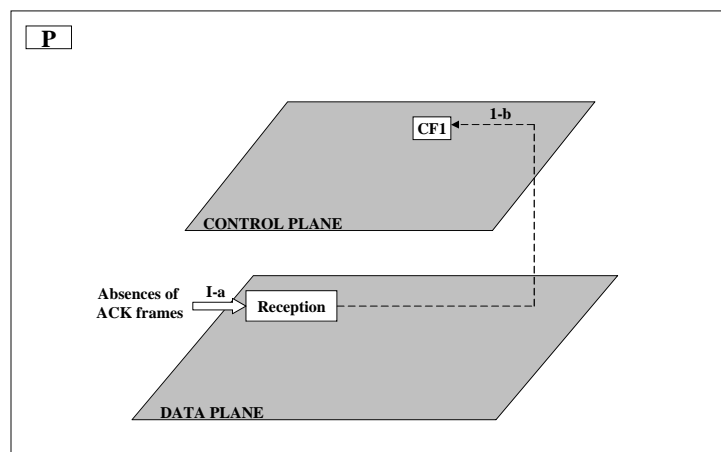

Figure 6.1.1.1: Cooperative mode activation in ProxyCoopSetup.

6.1.2. CoI Acquisitions

The objective of CoI acquisition is to provide cooperative information to the relay selecting algorithm. In ProxyCoopSetup, its relay selection algorithm is a centralized process; thus, the CoI has to be collected and forwarded to the CF3 block of the terminal in charge of the relay selection process, i.e., terminal N.

As shown in Fig.6.1.2.1, when the CF1 of terminal P is activated, the CF2 block of terminal P is triggered. The CF2 block communicates with the DP unit to create a control packet called ReREQ. The ReREQ is broadcasted from the emission block in the data plane to its neighbour terminals in order to activate and to invite the neighbour terminals to participate on CoI acquisition process; i.e., to collect and forward CoI. In addition, ReREQ packets are used to transport CoI.

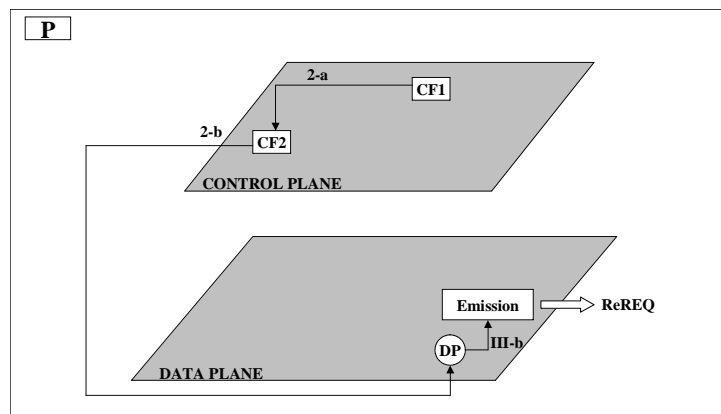

Figure 6.1.2.1: CoI acquisitions of ProxyCoopSetup at terminal P.

When the neighbour terminals of terminal P (terminal N and terminal R for examples) receive the ReREQ packet sent from terminal P, the “*C flag*” which is added to the ReREQ indicates that this packet is a ReREQ packet not a RREQ packet. Therefore, the CF1 blocks of terminal N and R are activated through 1-b and the CoI which is added into the ReREQ packet is extracted by the DP and sent to the CF2 blocks of terminal N and R (through 2-c) as shown in Fig.6.1.2.2 and Fig.6.1.2.3. In addition, “*a cooperative table*” is created and updated. Details of RREQ modifications and cooperative table will be later described.

The relay selections in ProxyCoopSetup is done at terminal N; thus, terminal R collect its CoI and sent to terminal N. The CF2 block in the control plane of terminal R communicates with its DP unit to create a ReREQ packet (see Fig.6.1.2.3). The ReREQ is broadcasted from the emission block in the data plane of terminal R to its neighbour terminals (terminal N in particular).

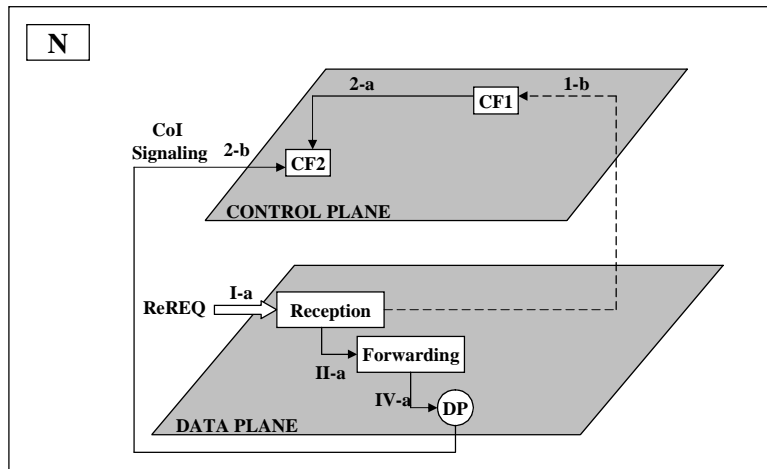

Figure 6.1.2.2: Cooperative mode activations and CoI acquisitions of ProxyCoopSetup at terminal N.

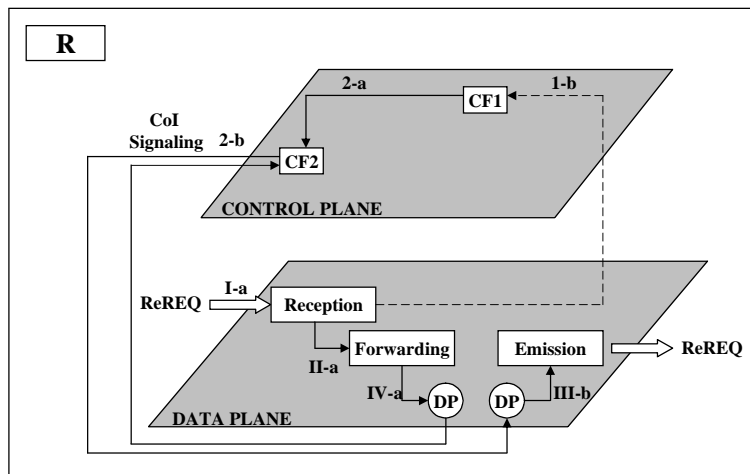

Figure 6.1.2.3: Cooperative mode activations and CoI acquisitions of ProxyCoopSetup at terminal R.

Cooperative Information (CoI)

The CoI is the information that is used in relay selection algorithm. From chapter 5 of this thesis, we concluded that the ProxyCoop transmission performance depends on the channel quality and channel availability of the relay terminal. So these parameters should be used by the relay selection algorithm.

Examples of CoI related to the channel quality of the relay terminal are the signal to noise ratios (SNRs) in the direct path (i.e., the path from terminal P to terminal N) and the proxy paths (i.e. paths from terminal P to R and from terminal R to N) or the probabilities of frame error in these paths (P1 and P2) that are used in the chapter 5. An example of CoI related to the channel availability of the relay terminal is the number of data frames sent by other terminals (except terminal P) per second that terminal R have heard.

Other examples of CoI that can be used in relay selection methods are data transmission rates, received signal powers, remaining energies, and queue sizes. Note that, relay selection methods can be done base one or multiple type of CoI.

In this chapter, SNRs of paths from terminal P to each potential relay terminal and SNRs of paths from each potential relay terminal to terminal N are used as CoI parameters.

ReREQ packet format

The ReREQ packet of ProxyCoopSetup is derived from the RREQ packet in the AODV routing protocol. The traditional RREQ packet format is shown in Fig.6.1.2.4 [PeRD03].

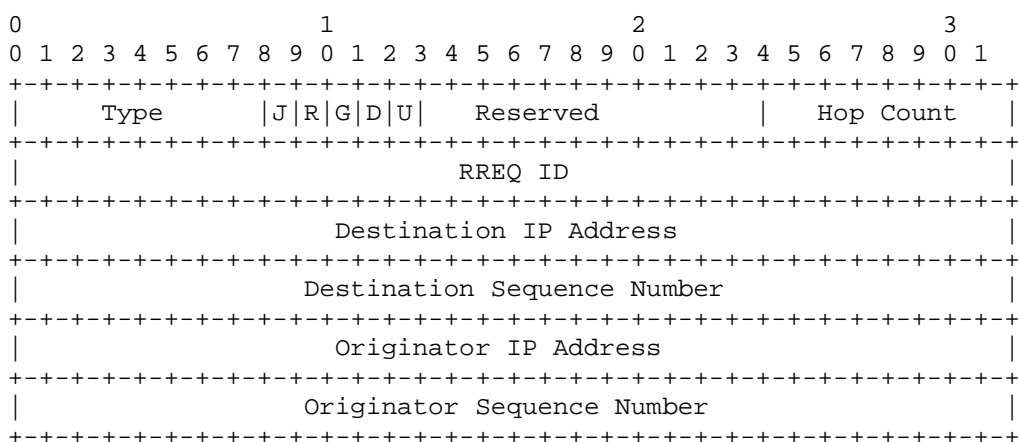

Figure 6.1.2.4: RREQ packet format.

- Type is used to indicate AODV packet type. Type of RREQ id set as 1.
- J, R, G, D, and U are flags.
 - J is a Join flag. It is reserved for multicast transmissions.
 - R is a Repair flag. It is reserved for multicast transmissions.
 - G is a Gratuitous RREP flag. It is used to indicate that a gratuitous RREP should be unicasted to the destination terminal even the RREP packet is replied by an intermediate terminal.
 - D is a Destination only flag. It is used to indicate that only the destination terminal can respond to this RREQ packet. Intermediate terminals cannot reply this RREQ packet.
 - U is an Unknown sequence number flag. It indicates that the destination sequence number is unknown.
- Reserved field is set as 0. These bits are ignored on receptions.
- Hop Count is the number of hops that RREQ is sent from the source terminal to the current terminal handling this RREQ packet.
- RREQ ID is a sequence number uniquely identifying the particular RREQ when taken in conjunction with the IP address of the source terminal.
- Destination IP Address is the IP address of the destination for which a route is desired.

Destination Sequence Number is the latest sequence number received in the past by the originator (the source terminal) for any route towards the destination.

Originator IP Address is the IP address of the terminal which originated the RREQ packet (the source terminal).

Originator Sequence Number is the current sequence number to be used in the route entry pointing towards the originator of the route request (the source terminal).

The ReREQ packet format is shown in Fig.6.1.2.5. Since the relay discovery process of ProxyCoopSetup happens in each transmission hop, the previous-hop terminal (terminal P) becomes an originator of the ReREQ packet and the next-hop terminal (terminal N) becomes a destination of the ReREQ packet.

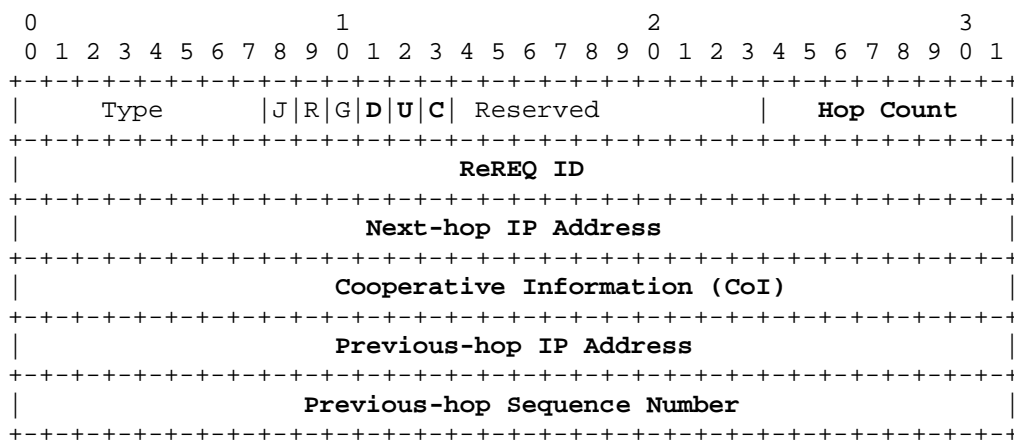

Figure 6.1.2.5: ReREQ packet format.

The modifications are as follows.

The D flag is set as “1” to indicate that the ReREQ is only replied by terminal N.

The U flag is set as “1” to indicate that the destination sequence number is unknown. This setting allows us to use the Destination Sequence Number of the RREQ as the Cooperative Information (CoI) field of the ReREQ packet. The CoI indicated in this field will be used in the relay selecting process of the ProxyCoopSetup.

A bit in the Reserved field is used as a C flag. This flag indicates terminals with cooperative functionality that this packet is a ReREQ packet, not a RREQ packet.

Hop Count is the number of hops that ReREQ is sent from a previous-hop terminal to the current terminal that receives this ReREQ packet.

RREQ ID is changed to ReREQ ID. It is a sequence number uniquely identifying the particular ReREQ when taken in conjunction with the IP address of the previous-hop terminal.

Destination IP Address is changed to Next-hop IP Address. This field indicates the IP address of the next-hop terminal (the destination terminal of ReREQ packet).

Destination Sequence Number is changed to Cooperative Information field. This field is used to carry the CoI, which is used by the relay selecting process.

Originator IP Address is changed to Previous-hop IP Address. It indicates the IP address of the previous-hop terminal.

Originator Sequence Number is changed to Previous-hop Sequence Number. It indicates the current sequence number to be used in the route entry pointing towards the previous-hop terminal.

ReREQ packet spreading

RREQ packets in AODV routing protocol are broadcasted and re-broadcasted through the network with the value indicated in the Time To Live (TTL). TTL is indicated in the RREQ packet IP header. When the RREQ is broadcasted or re-broadcasted, the value of TTL is decreased by one. Thus, the higher TTL value, the wider area of RREQ packets is spread as shown in Fig.6.1.1. Therefore, to alleviate network congestion problems caused by ReREQ spreading, the TTL value of ReREQ packets is set as 1. The ReREQ is re-broadcasted when these three conditions are satisfied.

ReREQ re-broadcasting conditions

1. The terminal is able to work with cooperative functions.
2. It is not terminal P.
3. The hopcount of ReREQ is equal to zero.

At the end of CoI acquisition process, ReREQ packets having their hopcount equal to zero and one are spread in the limited area. Terminal N will get ReREQ packets with 0-Hopcount and 1-Hopcount. The CoI in the ReREQ packet with 0-Hopcount indicates the CoI of the direct path (P to N) while the CoI in the ReREQ packet with 1-Hopcount indicates the CoI of the i^{th} proxy path (P to R_i to N). Therefore, CoI of the direct path and all of the proxy paths can be compared at terminal N. ReREQ is spread as shown in Fig.6.1.2.6. R_i is the i^{th} potential relay terminal located between terminal P and terminal N. C_i are terminals with cooperative functionality while T_i are terminals without cooperative functionality. As shown in Fig.6.1.2.6, instead of spreading the ReREQ through the network, ReREQ is spread in the limited area.

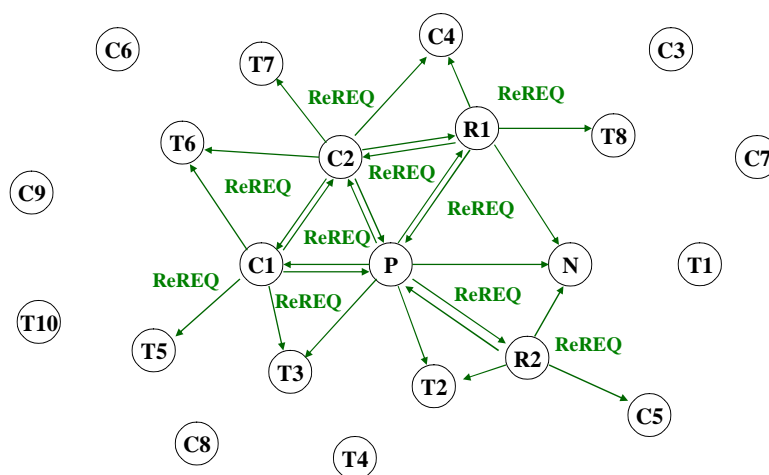

Figure 6.1.2.6: ReREQ packet spreading.

How to treat ReREQ packets

When terminals receive a ReREQ packet, they treat the ReREQ packet differently depending on its cooperative capability (i.e., terminals with or without cooperative functionality) and its role in the cooperative network (i.e., the originator or the destination terminal of the ReREQ packet, PRTs, or neighbour terminals of PRTs).

▪ ***Terminals without cooperative functionality***

Because a ReREQ packet has its packet format similar to a RREQ packet, terminals without cooperative functionality treat it as an ordinary RREQ packet. Terminals create and update their routing table. However, the ReREQ will not be re-broadcasted because its TTL reaches to zero.

▪ ***Terminal with cooperative function***

The packet will be treated differently depends on the role of each terminal in the cooperative network.

Potential relay terminal (PRT)

The PRT is a terminal located between terminal P and N. It receives ReREQ packets with 0-Hopcount and 1-Hopcount. It treats each ReREQ packet as follows;

- Its cooperative table is created or updated related to the terminal sending this ReREQ packet.
- CoI in the ReREQ packet is extracted and added into the cooperative table.
- Each PRT measures the SNR of the received ReREQ packet and fills in its cooperative table.
- If the received ReREQ packet having its hopcount equals to zero, the PRT added the measured SNR into its ReREQ packet and re-broadcasts the ReREQ with TTL equals to one.

Terminal N

Terminal N is a destination terminal of the ReREQ packet. The received ReREQ packets having their hopcount equal to zero and one. Each ReREQ packet is treated as follows;

- Its cooperative table is created or updated.
- CoI in the ReREQ packet is extracted and added into the cooperative table.
- It measures the SNR of the received ReREQ packet and fills in its cooperative table.
- It is a destination terminal of the ReREQ packet; thus, the ReREQ will not be re-broadcasted.

Terminal P

Terminal P is the originator of the ReREQ packet. Thus, it receives only the re-broadcasted ReREQ packets with hopcount equal to one. Each ReREQ packet is treated as follows;

- Its cooperative table is created or updated.
- The SNR of the received ReREQ is measured and filled in the cooperative table.

- It will not re-broadcast the ReREQ since it is an originator of the ReREQ packet.

Neighbour terminals of PRTs

The neighbour terminals of PRTs always receive ReREQ packets with 1-Hopcount. Each ReREQ packet is treated as follows;

- Its cooperative table is created or updated.
- CoI in the ReREQ packet is extracted and added into the cooperative table.
- Each PRT measures the SNR of the received ReREQ packet and fills in its cooperative table.
- Since the Hopcount of the ReREQ packet equals to one, neighbour terminal will not re-broadcast this ReREQ.

Cooperative table update

Similar to AODV routing protocol, when terminals with cooperative functionality receive ReREQ packets, their cooperative table is created or updated. In CoI acquisitions, terminal P, R and N exchange their cooperative control packets as shown in Fig.6.1.2.7. The cooperative tables of terminal P, R and N are updated as follows.

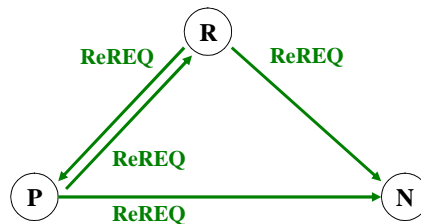

Figure 6.1.2.7: ReREQ packets in CoI acquisitions.

In this example, we assume that the CoI acquisition process has to collect and forward the SNR_{PN} , SNR_{PRi} and SNR_{RiN} values to terminal N. SNR_{PN} stands for the SNR of the direct link between terminal P and terminal N, SNR_{PRi} stands for the SNR of the link between terminal P and i^{th} potential relay terminal, and SNR_{RiN} stands for the SNR of the link between i^{th} potential relay terminal and terminal N. These values will be compared by the relay selection method.

Cooperative tables of terminal R, N, and P after the CoI acquisition has been processed are shown in Table.6.1.2.1, Table.6.1.2.2, and Table.6.1.2.3 respectively. In the tables, current SNR stands for the SNR that we can measure at the current terminal when the ReREQ is received. The previous SNR stands for the SNR that was measured when the ReREQ was received by the previous terminal. The previous SNR is indicated in the “*Cooperative Information field*” of the ReREQ packet.

Cooperative table of terminal R

In the CoI acquisition process, terminal R receives a ReREQ packet sent from terminal P; thus, a cooperative entry relating to terminal P is created in the cooperative routing table

of terminal R as shown in Table 6.1.2.1. Since terminal P is the originator of the ReREQ packet, the previous SNR is equal to zero. Thus, terminal P put zero in the Cooperative Information field of the ReREQ packet.

Dest IP	Next IP	Coop Capacity	Hop Count	Prev. SNR	Current SNR
IP_P	IP_P	YES	0	0	SNR_{PR}

Table 6.1.2.1: Cooperative Table of terminal R after the CoI acquisition process.

Cooperative table of terminal P

Terminal P receives a ReREQ packet sent from terminal R; thus, cooperative entry relating to terminal R is created in its cooperative routing table as shown in Table 6.1.2.3.

Dest IP	Next IP	Coop Capacity	Hop Count	Prev. SNR	Current SNR
IP_R	IP_R	YES	0	0	SNR_{PR}

Table 6.1.2.3: Cooperative Table of terminal P after the CoI acquisition process.

Cooperative table of terminal N

Terminal N receives ReREQ packets sent from terminal P and terminal R; thus, cooperative entries relating to terminal P and R are created in its cooperative routing table as shown in Table 6.1.2.2. Terminal R has put the SNR_{PR} that it has measured when the ReREQ sent from terminal P was received into the Cooperative Information field of the ReREQ packet; thus, the previous SNR of a cooperative entry relating to terminal R in the table is equal to SNR_{PR} .

Dest IP	Next IP	Coop Capacity	Hop Count	Prev. SNR	Current SNR
IP_P	IP_P	YES	0	0	SNR_{PN}
IP_R	IP_R	YES	0	0	SNR_{RN}
IP_P	IP_R	YES	1	SNR_{PR}	SNR_{RN}

Table 6.1.2.2: Cooperative Table of terminal N after the CoI acquisition process.

After CoI acquisitions, terminal N gets CoI from all potential relay terminals. This information is forwarded to its CF3 block to be used by the relay selection method.

6.1.3. Relay Selection Methods

The relay selection method is based on the CoI acquired in the previous step (i.e., the CoI acquisition).

Centralized relay selection method

The relay selection of ProxyCoopSetup is a centralized method meaning that CoI of all potential relay terminals acquired from CoI acquisition processes are compared at terminal N and the best relay terminal is chosen. Since CoI of every potential relay terminal is compared in centralized relay selecting method, optimal relay selections are provided. In addition, the hidden terminal problems among potential relay terminals are alleviated.

Decisions of proxy cooperative transmissions or non-cooperative transmissions

One of the advantages provided by ProxyCoopSetup is that the CoI of the direct path (from P to N) and CoI of every i^{th} proxy path (from P to R_i to N) can be compared. Thus, based on cooperative capability provided by the proxy path, the relay selection method knows that the network should remain to transmit in non-cooperative mode or it should switch to transmit in proxy cooperative one.

If the transmission performance (in term of PDR or transmission rate, for instance) is guaranteed to be improved by ProxyCoop transmissions, a control packet called ReREP, which is derived from RREP packet of AODV routing protocol, is sent to the chosen relay terminal R and forwarded to terminal P. Otherwise, a ReREP packet should be sent directly to terminal P to remain the transmission mode in non-cooperative mode. Details of ReREP packet will be later given.

Single relay selection

The relay selection method of ProxyCoopSetup is designed to support single relay selection that is used in ProxyCoop transmissions. If relay selection method of the ProxyCoopSetup finds that proxy cooperative transmissions can gain the system performance (in term of PDR for example), a single relay terminal is chosen to work as a relay terminal.

Relay selection update

Generally, relay selections can be done either on a per flow basis (to support connection-oriented transmissions) or a per frame basis (to support connectionless transmissions). For connection-oriented transmission methods, the relay selections will be done once and the chosen relay terminal will be used in multiple data frames, or until the end of data transmissions, or until route recovery processes are required. In contrast, for connectionless, the relay selections are done in every single data frame transmission. Thus, every PRT of per frame basis relay selections has to always stay in active mode in order to listen, to receive, and/or to transmit control frames and/or data frames.

Fig.6.1.3.1a shows an example of per frame basis relay selections. Every PRT (R_i) stays in the active mode to receive the data frame sent by a source terminal S. Then, selecting processes are done and the chosen relay terminal relays the data frame to the destination terminal D. In contrast, for per flow basis relay selections, since the relay selection processes have already done, only the chosen PRT (i.e., R2) has to stay in the active mode (see Fig.6.1.3.1b). Other PRTs can stay in idle mode during the transmission; thereby they can reduce their energy cost.

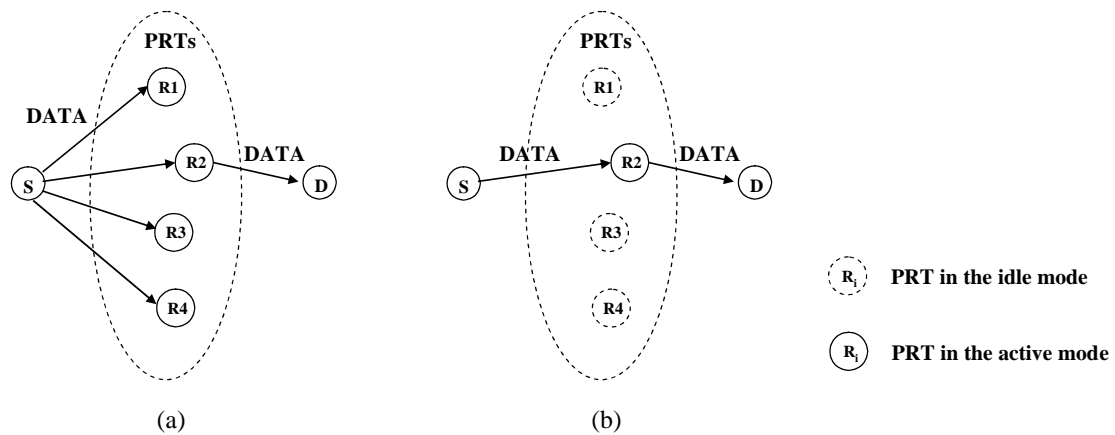

Figure 6.1.3.1: Data transmissions when relay selection is based on (a) per frame basis and (b) per flow basis.

In power conservative point of view, transmitting, receiving, and listening to an idle radio channel require comparable amount of power. The only way to save substantial energy is to allow mobile terminal to be powered off or to be switched in an idle mode [ZoRo03a] and [ZoRo03b].

Therefore, in these contexts, the relay selection method in ProxyCoopSetup is design to support *connection-oriented transmissions*. The chosen relay terminal will be used until the direct link is broken and a route re-discovery is processed.

6.1.4. Cooperative mode notifications

The objective of the cooperative mode notification is to notify every cooperative participating terminal (i.e. terminal P, terminal N and every PRT) whether they have to work in cooperative transmissions or not.

Based on our cooperative network model, cooperative mode notifications can be separated into two groups; i.e. the notification among cooperative participating terminals (through 4-b) and the notification between planes (through II-b). In this chapter, we focus

only on the notification among cooperative participating terminals since the notification between planes have been already presented in chapter 5.

After the relay selection have been done by the CF3 block of terminal N, terminal N notifies the result to the chosen relay terminal (we assume that terminal R is chosen to work as a relay terminal) and to terminal P by using a control packet called ReREP. The ReREP packet is derived from RREP packet of the AODV routing protocol. It will be sent from terminal N to terminal R, then terminal R forwards it to terminal P.

As shown in Fig.6.1.4.1, the CF4 block communicates with the DP to create a ReREP packet. The ReREP is unicasted from the emission block in the data plane of terminal N to the reception block of terminal R. The ReREP packet is used to notify terminal R that it is chosen to work as a relay terminal. Similar to RREP packets, the ReREP packet must be unicastedly transmitted from terminal N to terminal R. Terminal N must know the MAC address of terminal R. This MAC address is provided by the ARP process that is used in AODV routing protocol. After the ARP process has been performed, terminal N and R knows the MAC address of each other.

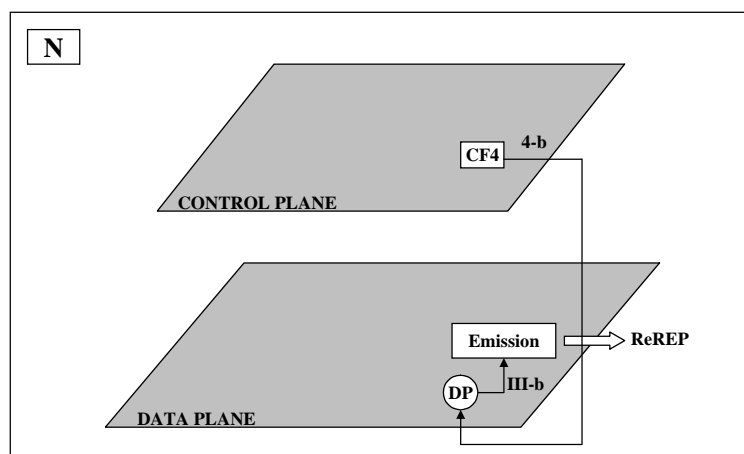

Figure 6.1.4.1: Cooperative mode notifications of ProxyCoopSetup at terminal N.

When terminal R receives the ReREP packet sent from terminal N, the “*C flag*” which is added to the ReREP indicates that this packet is a ReREP packet not a RREP packet. Therefore, the CF4 block of terminal R is notified and terminal R knows that it has to work in proxy cooperative transmission mode. Control data in the ReREP are processed by the DP block in the data plane and are sent to the CF4 block in the control plane as shown in Fig.6.1.4.2. The Previous-hop IP address and the Next-hop IP address in the ReREP informs that terminal R has to work on data relaying for this transmission pair.

For the next step, terminal R has to notify terminal P to work in cooperative transmission mode. The ReREP is unicasted from the emission block in the data plane of terminal R to

the reception block of terminal P. Again, terminal R processes the ARP to acquire the MAC address of terminal P. After ARP have processed, terminal R and P knows the MAC address of each other.

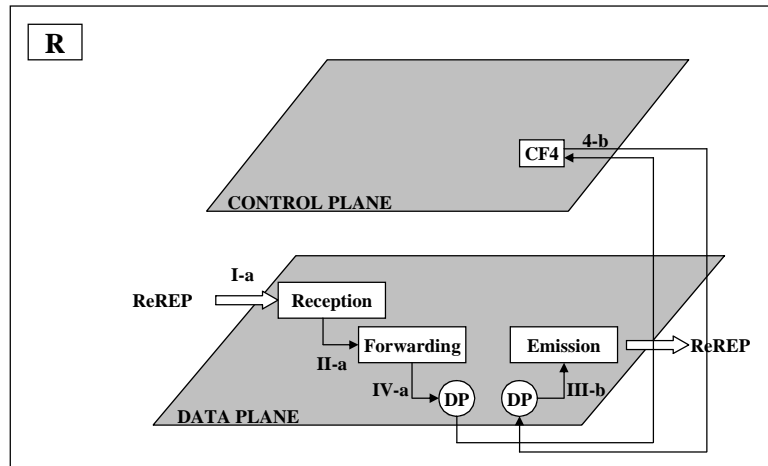

Figure 6.1.4.2: Cooperative mode notifications of ProxyCoopSetup at terminal R.

Similar to terminal R, the “*C flag*” which is added to the ReREP indicates terminal P that this packet is a ReREP packet not a RREP packet. Therefore, the CF4 block of terminal P is notified that it has to work in proxy cooperative transmission mode as shown in Fig.6.1.4.3.

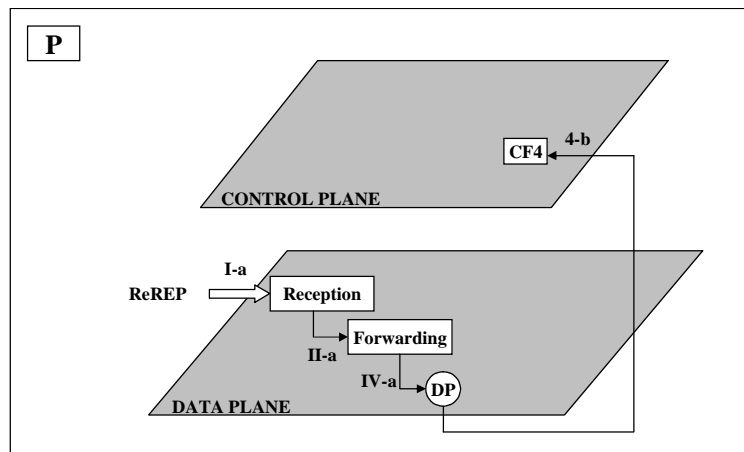

Figure 6.1.4.3: Cooperative mode notifications of ProxyCoopSetup at terminal P.

From now, ProxyCoopSetup is finished. Terminal P, R, and N know that they have to work in proxy cooperative mode. From ARP processes, terminal R knows the MAC addresses of terminal P and N; thus, terminal R can filter and forward data frames of this

transmission pair correctly. The chosen relay terminal will be used until the direct path is broken and a route re-discovery is processed.

ReREP packet format

The ReREP packet of ProxyCoopSetup is derived from the RREP packet of the AODV routing protocol. The traditional RREP packet format is shown in Fig.6.1.4.4.

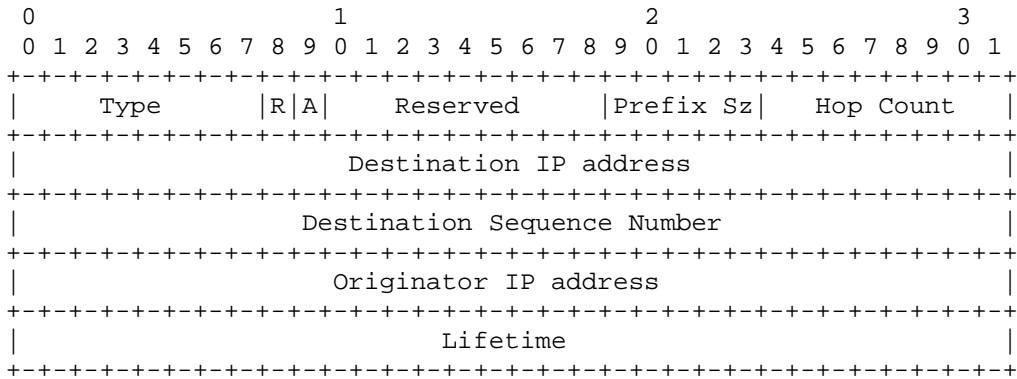

Figure 6.1.4.4: RREP packet format.

- Type 2 indicates that this is a RREP packet.
- R is a Repair flag. It is used for multicast.
- A is an Acknowledgment required flag.
- Reserved is set as 0. This field will be ignored on reception.
- Prefix Size If nonzero, the 5-bit Prefix Size specifies that the indicated next hop may be used for any terminals with the same routing prefix (as defined by the PrefixSize) as the requested destination [PeRD03].
- Hop Count is the number of hops from the Originator IP Address (terminal S) to the Destination IP Address (terminal D). For multicast route requests this indicates the number of hops to the multicast tree member sending the RREP.
- Destination IP Address is the IP address of the destination for which a route is supplied (terminal D).
- Destination Sequence Number is the destination sequence number associated to the route.
- Originator IP Address is the IP address of the terminal which originated the RREQ (terminal S) for which the route is supplied.
- Lifetime is the time in milliseconds for which terminals receiving the RREP consider the route to be valid.

The ReREP packet format is shown in Fig.6.1.4.5. Since the relay discovery process of ProxyCoopSetup happens in each transmission hop, previous-hop terminal becomes an originator of the ReREP packet and next-hop terminal becomes a destination of the ReREP packet.

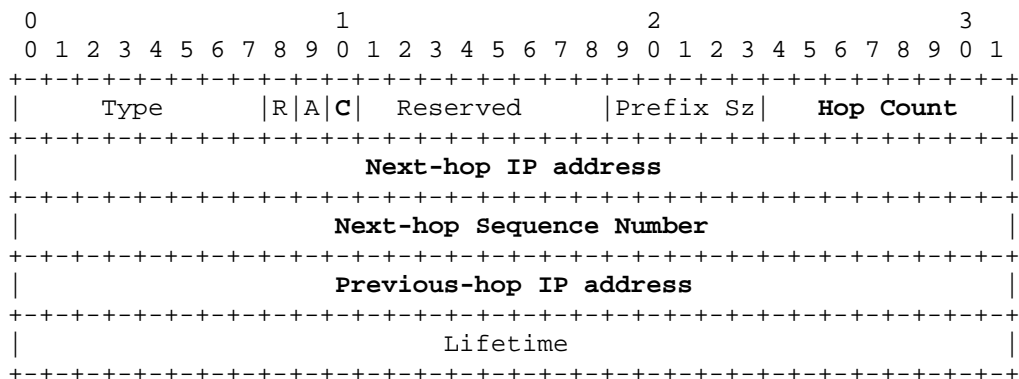

Figure 6.1.4.5: ReREP packet format.

The modifications are as follows.

A bit in the Reserved field is used as a C flag. This flag indicates terminals with cooperative functionality that this packet is a ReREP packet, not a RREP packet.

Hop Count is the number of hops that ReREP is sent from a next-hop terminal to the current terminal processing this ReREP packet.

Destination IP Address is changed to Next-hop IP address. It indicates the IP address terminal N.

Destination Sequence Number is changed to Next-hop Sequence Number. It indicates the next-hop sequence number associated to the route.

Originator IP Address is changed to Previous-hop IP Address. It indicates the IP address of the terminal which originated the ReREQ (terminal P) for which the route is supplied.

When the chosen relay terminal receives a ReREP packet, the Previous-hop IP address and the Next-hop IP address fields inform the chosen relay terminal that it has to work on data relaying for this transmission pair.

Cooperative table update

In the cooperative mode notification of ProxyCoopSetup, when terminals with cooperative functionality receive ReREP and ARP packets, their cooperative table is created or updated.

Cooperative tables of terminal R, N, and P after cooperative mode notifications have been processed are shown in Table 6.1.4.1, 6.1.4.2, and 6.1.4.3 respectively. The italic information in the table indicates that this information is acquired by ReREQ packets in the CoI acquisition. The bold information in the table indicates that this information is acquired by ReREP packets in the cooperative mode notification and the bold italic information indicates that this information is acquired by the ARP process.

Cooperative table of terminal R

In cooperative mode notifications, terminal R receives a ReREP packet unicastly sent from terminal N; thus, a cooperative entry relating to terminal N is created in its cooperative table. In addition, the ARP process provides the MAC address of terminal N to terminal R and when the ReREP packet is forwarded from terminal R to terminal P, the ARP provides the MAC address of terminal P to terminal R as shown in Table 6.1.4.1.

Dest IP	Next IP	Coop Capacity	Hop Count	Prev. SNR	Current SNR	MAC Add.
<i>IP P</i>	<i>IP P</i>	<i>YES</i>	<i>0</i>	<i>0</i>	<i>SNR_{PR}</i>	<i>MAC P</i>
<i>IP N</i>	<i>IP N</i>	<i>YES</i>	<i>0</i>			<i>MAC N</i>

Table 6.1.4.1: Cooperative Table of terminal R after the cooperative mode notification.

Cooperative table of terminal N

When the ReREP packet is unicastly sent from terminal N to terminal R, the ARP provides the MAC address of terminal R to terminal N as shown in Table 6.1.4.2.

Dest IP	Next IP	Coop Capacity	Hop Count	Prev. SNR	Current SNR	MAC Add.
<i>IP P</i>	<i>IP P</i>	<i>YES</i>	<i>0</i>	<i>0</i>	<i>SNR_{PN}</i>	
<i>IP R</i>	<i>IP R</i>	<i>YES</i>	<i>0</i>	<i>0</i>	<i>SNR_{RN}</i>	<i>MAC R</i>
<i>IP P</i>	<i>IP R</i>	<i>YES</i>	<i>1</i>	<i>SNR_{PR}</i>	<i>SNR_{RN}</i>	

Table 6.1.4.2: Cooperative Table of terminal N after the cooperative mode notification.

Cooperative table of terminal P

When the ReREP packet is unicastly forwarded from terminal R to terminal P, the ARP provides the MAC address of terminal R to terminal P (see Table 6.1.4.3).

Dest IP	Next IP	Coop Capacity	Hop Count	Prev. SNR	Current SNR	MAC Add.
<i>IP R</i>	<i>IP R</i>	<i>YES</i>	<i>0</i>	<i>0</i>	<i>SNR_{PR}</i>	<i>MAC R</i>

Table 6.1.4.3: Cooperative Table of terminal P after the cooperative mode notification.

After cooperative mode notification, ProxyCoopSetup is finished. Terminal P, R, and N know that they have to work in proxy cooperative mode. The ARP provides the MAC addresses of terminal P and N to terminal R; thus, it can filter and forward data frames of the P-N pair correctly.

6.2. PROXYCOOPSETUP PERFORMANCE

The objective of this section is to study costs of ProxyCoopSetup when it works with ProxyCoop transmissions. The evaluation is achieved by NS2 simulator [NeSi10].

The performance of non-cooperative transmissions, ProxyCoop transmissions with ProxyCoopSetup and ProxyCoop transmissions without ProxyCoopSetup are evaluated in two metrics. First, the transmission performance is evaluated in terms of PDR. PDR is the ratio of the number of received data frames to the number of transmitted data frames. Second, the administrative (routing) performance is evaluated in terms of NRDM per second. NRDM is the number of RREQ packets sent by S to discover and re-discover a route from S to D during the simulations.

6.2.1. System Model and Simulation Parameters

Similar to chapter 5 of this thesis, a simple scenario of 3-terminal network and a 9-terminal network, as shown in Fig.6.2.1.1 and Fig.6.2.1.2, are simulated.

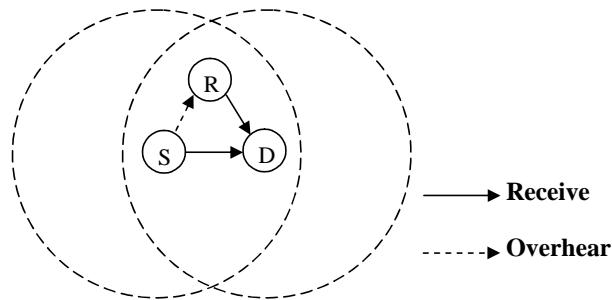

Figure 6.2.1.1: A 3-terminal network.

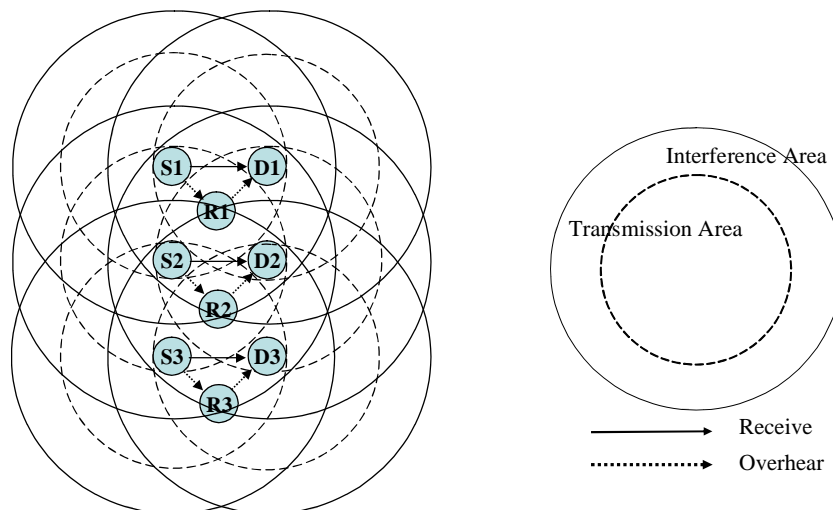

Figure 6.2.1.2: A 9-terminal network.

For the ProxyCoop transmission without ProxyCoopSetup, terminal R is assumed to be already chosen. Thus, cooperative functions in the control plane do not have to be processed. In contrast, the ProxyCoop transmission with ProxyCoopSetup has to process its cooperative setup functions to acquire a relay terminal.

However, in order to compare costs of ProxyCoopSetup in the ProxyCoop transmissions with and without ProxyCoopSetup method, we set our scenario to be independent from the relay selection algorithm. In each transmission pair, there is only one potential relay terminal to be chosen; thus, the performance of ProxyCoop transmissions with and without ProxyCoopSetup related to relay selection algorithm is similar. The difference between these two transmission methods is the costs of processing delay and resource consumption that are used in the ProxyCoopSetup process.

6.2.2. Simulation Results and Analysis

The NRDM per second and the PDR of non-cooperative transmissions, ProxyCoop transmissions with ProxyCoopSetup, and ProxyCoop transmissions without ProxyCoopSetup in the 3-terminal network are respectively shown in Fig.6.2.2.1 and Fig.6.2.2.2.

The x-axis of Fig.6.2.2.1 and Fig.6.2.2.2 represents the ratio of P1 to P2. In each case, the value of P1 is fixed (at 0.1 or 0.2) while the value of P2 is varied. On the left-hand side of the graph, the value of P2 is higher than that of the right-hand side meaning that the channel quality of the proxy path on the left-hand side of the graph is worse than the right-hand side of the graph. The y-axis of Fig.6.2.2.1 represents NRDM per second while the y-axis of Fig.6.2.2.2 represents the PDR value.

Analysis of NRDM per second

In this chapter, we focus on NRDM comparisons between ProxyCoop transmissions with and without ProxyCoopSetup. As shown in Fig.6.2.2.1, the NRDMs per second of ProxyCoop transmission with and without ProxyCoopSetup are very similar. Therefore, it can be concluded that ProxyCoopSetup does not have impacts to the NRDM values. The NRDM per second is only a function of channel quality of the direct and the proxy paths.

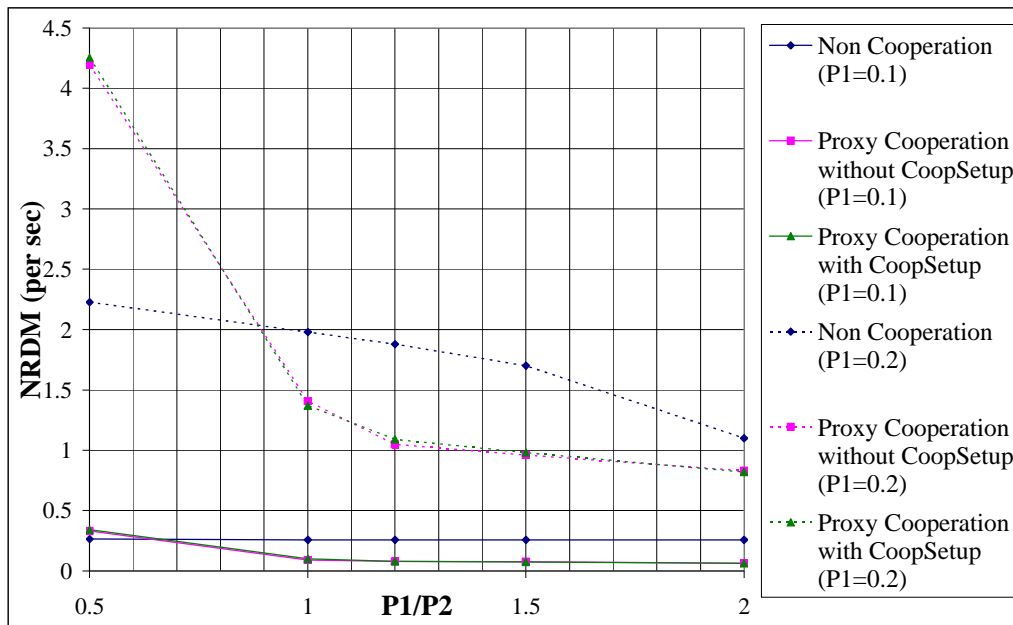

Figure 6.2.2.1: The number of route discovery and maintenance (NRDM) per second of the 3-terminal network.

PDR analysis

In order to study the costs of ProxyCoopSetup in term of PDR, in this chapter, the PDRs of ProxyCoop transmissions with and without ProxyCoopSetup are compared. As shown in Fig.6.2.2.2, ProxyCoop transmission without ProxyCoopSetup provides higher PDR than ProxyCoop transmission with ProxyCoopSetup since ProxyCoopSetup gains processing delay and it consumes resource of the systems. Nevertheless, the PDR of ProxyCoop transmission with ProxyCoopSetup is dropped only 0.11% - 5.50% compared to the PDR of ProxyCoop transmission without ProxyCoopSetup. Similar to ProxyCoop transmissions without ProxyCoopSetup, the ProxyCoop transmissions with ProxyCoopSetup can provide better performance than the non-cooperative transmission when the channel quality of the proxy paths is higher than that of the direct path and there are probabilities of multi-hop transmission mode transitions.

Since ProxyCoopSetup is a reactive method, it is processed only when the direct path has problem on its transmission. Moreover, the ProxyCoopSetup is designed to support connection-oriented transmissions; thus, once the ProxyCoopSetup has been processed, the chosen relay terminal acquired from relay selection process will be used until the direct link is broken and a route re-discovery is processed. Therefore, if the NRDM in ProxyCoop transmission with ProxyCoopSetup is decreased, the probability that ProxyCoopSetup will be processed or re-processed is also decreased.

Fig.6.2.2.1 and Fig.6.2.2.2 confirm that ProxyCoopSetup performance in term of PDR is related to the NRDM per second. When the NRDM is reduced, ProxyCoop transmission with ProxyCoopSetup has its PDR closely to ProxyCoop transmission without ProxyCoopSetup.

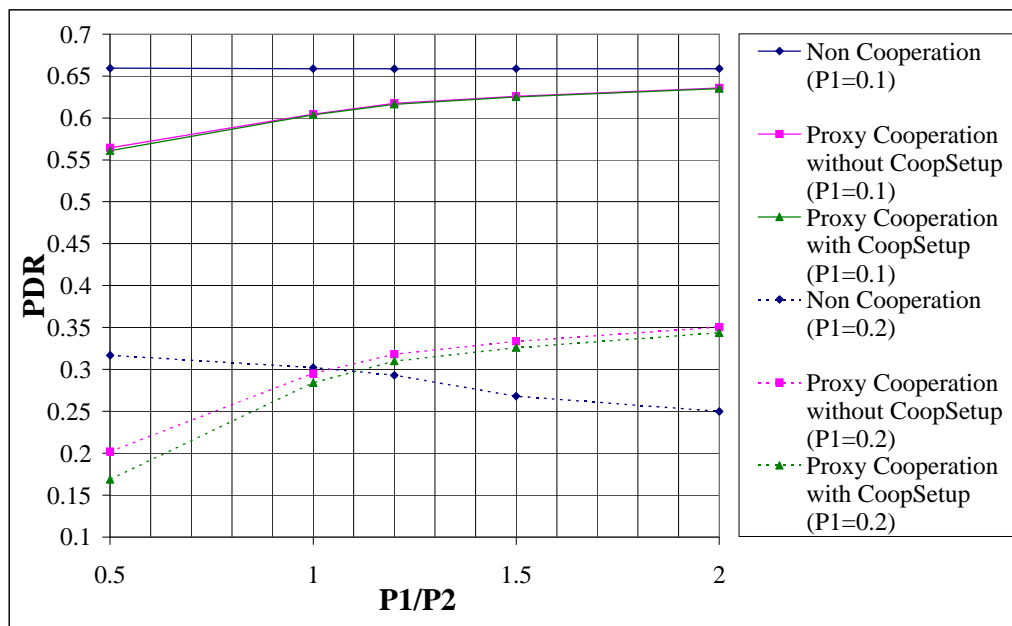

Figure 6.2.2.2: Packet delivery ratio (PDR) of the 3-terminal network.

For 9-terminal network, the NRDM per second and the PDR of every transmission method are respectively shown in Fig.6.2.2.3 and Fig.6.2.2.4.

The x-axis of Fig.6.2.2.3 and Fig.6.2.2.4 represents the ratio of P1 to P2. In each case, the value of P1 is fixed (at 0.1 or 0.2) while the value of P2 is varied. The y-axis of Fig.6.2.2.3 represents the NRDM per second while the y-axis of Fig.6.2.2.4 represents the PDR values.

Analysis of NRDM per second

Similar to 3-terminal network, the NRDMs per second of ProxyCoop transmission with and without ProxyCoopSetup are very similar (see Fig.6.2.2.3). Thus, it shows that ProxyCoopSetup does not have any impacts to the NRDM values in the system. Thus, it re-confirms that the NRDM per second is only a function of channel quality of the direct path and the proxy path.

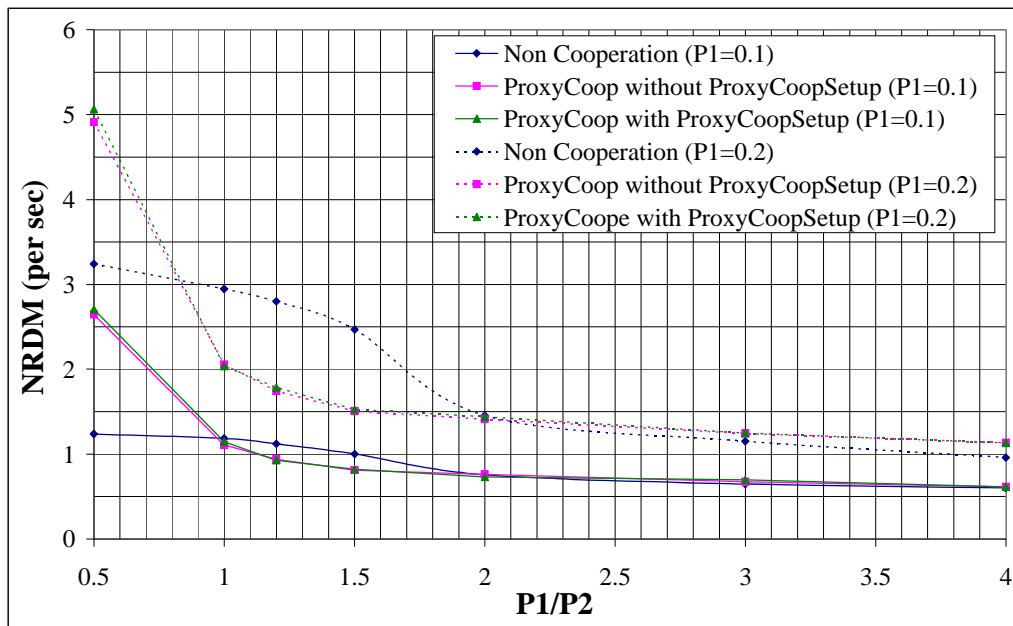

Figure 6.2.2.3: The number of route discovery and maintenance (NRDM) per second of the 9-terminal network.

PDR analysis

As shown in Fig.6.2.2.4, ProxyCoop transmission without ProxyCoopSetup provides higher PDR than ProxyCoop transmission with ProxyCoopSetup since ProxyCoopSetup gains processing delay and it consumes resource of the systems. The PDR of ProxyCoop transmission with ProxyCoopSetup is dropped 0.87% - 13.56% compared to the PDR of ProxyCoop transmission without ProxyCoopSetup depending on the channel quality of the proxy path compared to the direct path. However, similar to the ProxyCoop transmissions without ProxyCoopSetup, the ProxyCoop transmissions with ProxyCoopSetup can provide better performance than the non-cooperative transmission when the channel quality of the proxy paths is higher than that of the direct path and there are probabilities of multi-hop transmission mode transitions.

Fig.6.2.2.3 and Fig.6.2.2.4 confirm that ProxyCoopSetup performance in term of PDR is related to the NRDM per second. When the NRDM is reduced, ProxyCoop transmission with ProxyCoopSetup has its PDR closely to ProxyCoop transmission without ProxyCoopSetup.

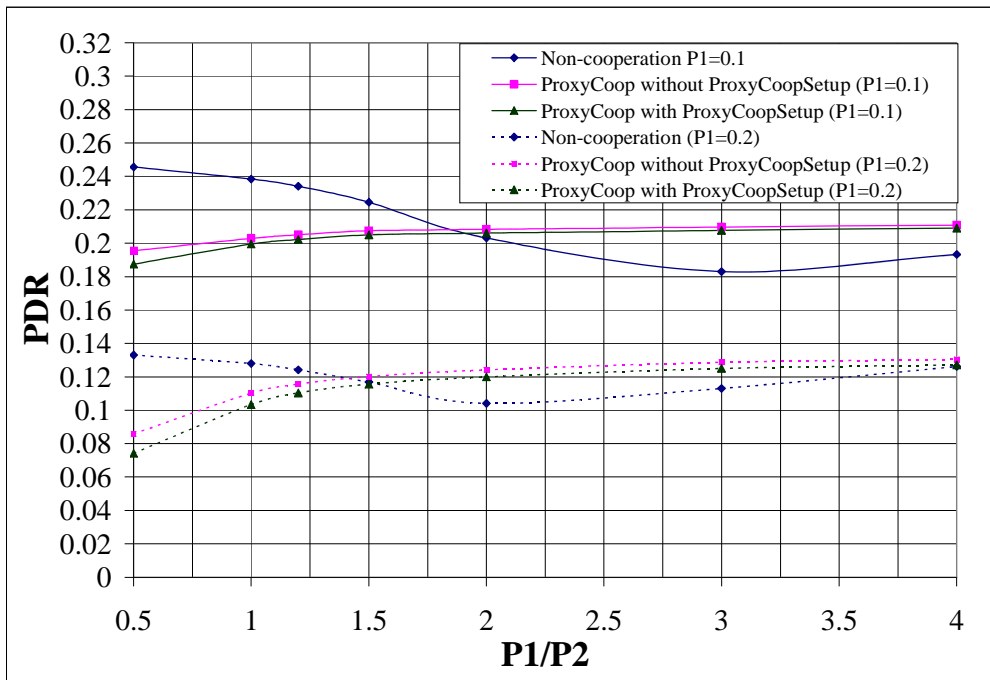

Figure 6.2.1.4: Packet delivery ratio (PDR) of the 9-terminal network.

6.3. PROXY COOPERATIVE COMMUNICATIONS IN IEEE 802.11S WLAN MESH NETWORKS

In chapter 5 and the previous sections of chapter 6, the designs of proxy cooperative communication in parts of proxy cooperative transmission and proxy cooperative setup have been done. In addition, the interest of the propositions in term of performance has been presented. In this section, we focus on the implementation of the proxy cooperative communication and how it can be integrated on existing networks.

WLAN Mesh Networks (WMNs), which are studied by IEEE 802.1s group, is an example of existing networks that we consider. Rather than to interconnect Basic Service Sets (BSSs) of wireless LAN (WLAN) networks by a wired Ethernet system as shown in Fig.6.3.1, the 802.11s group proposes a wireless mesh network to provide wireless interconnection between BSSs of WLAN networks as shown in Fig.6.3.2.

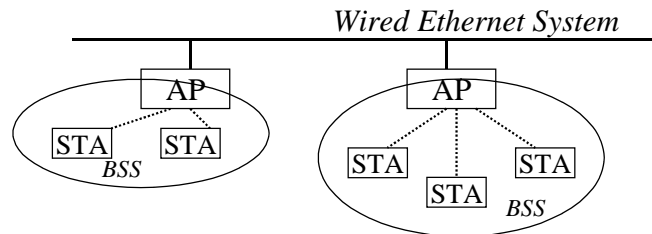

Figure 6.3.1: Network architecture of IEEE 802.11 WLANs.

- The access point (AP) is a device that allows a wireless network to be able to connect with wired communication devices.
- STA (Station) is a conventional (or legacy) WLAN client.
- Basic Service Set (BSS) is used to call a single AP together with all associated STAs which is the basic building block of an IEEE 802.11 WLAN.

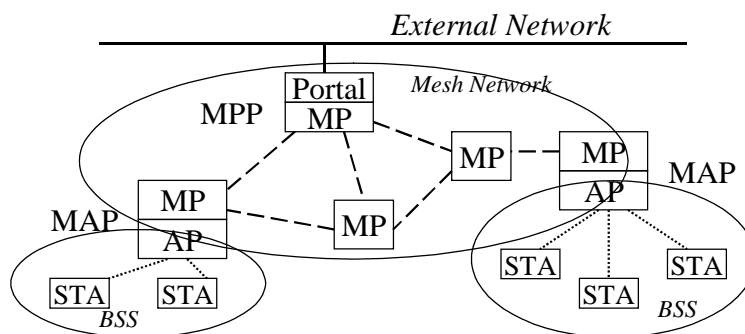

Figure 6.3.2: Network architecture of IEEE 802.11s WMNs.

- The Mesh Point (MP) is an IEEE 802.11 station with mesh capabilities. The MPs communicate together without infrastructure.
- The Mesh Access Point (MAP) is a MP having an AP functionality so that wireless station can work in 802.11 mode with infrastructure, forming a Basic Service Set (BSS)
- STA is a conventional (or legacy) WLAN client, which is a non-mesh IEEE 802.11 station.
- A MP with additional portal function is called mesh portal (MPP). It can bridge data frames to other IEEE 802 networks.

Proxy cooperative transmission can be applied into two places in WMNs. First, it can be applied to gain signal diversity in BSS as shown in Fig.6.3.3.3 a1 and 6.3.3.3a2. Second, (see Fig.6.3.3.3b), it can be applied to gain the signal diversity at the MP level of mesh networks.

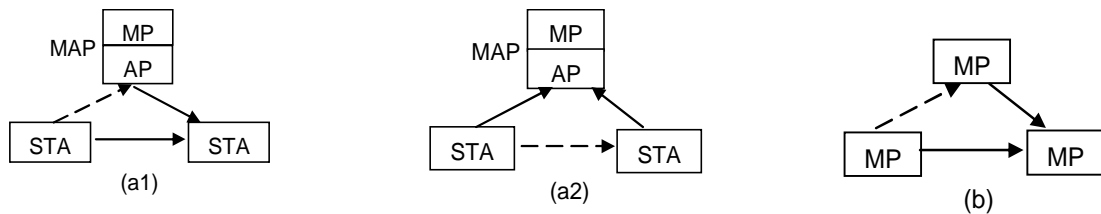

Figure 6.3.3.3: Proxy cooperation (a1) and (a2) in BSS (b) in mesh networks.

In addition, routing protocols of WLAN have been proposed in the network layer (layer 3) but WMN proposes its routing protocol called Hybrid Wireless Mesh Protocol (HWMP) in the data link layer (layer 2). In IEEE 802.11s draft, every mesh terminal is required to implement the default routing protocol HWMP. It allows each mesh terminal to create a MAC address table of its neighbor MP.

Thus, ProxyCoop transmission can be easily applied because its data forwarding requires a pair of STA MAC addresses or a pair of MP MAC addresses to filter and forward the MAC data frames, which are already provided by the HWMP routing protocol.

In addition, HWMP is a hybrid routing protocol having both of reactive and proactive routing components. The reactive routing part is derived from the AODV protocol which is used and modified in ProxyCoopSetup method. Besides, some metrics related to the Channel State Information (CSI) are specified to the routing process. The CSI will benefit to or it can be reused by ProxyCoopSetup method. Therefore, these properties enable the implementation of Proxy cooperative communications in WMNs.

6.4. CONCLUSION

In this chapter, the design of cooperative setup part of cooperative communications called “ProxyCoopSetup” has been done. The cooperative network model has been used for the ProxyCoopSetup design.

After the designs, ProxyCoopSetup performance and its impacts to ProxyCoop transmissions have been evaluated by simulations. The objective of the simulation is to study the costs of ProxyCoopSetup when it works with ProxyCoop transmissions. The costs of ProxyCoopSetup can be evaluated by comparing the performance of ProxyCoop transmissions with and without ProxyCoopSetup in terms of PDR and NRDM per second.

From simulation results, ProxyCoop transmission with ProxyCoopSetup can have its transmission performance in term of PDR similar to ProxyCoop transmissions without ProxyCoopSetup. In addition, it can be concluded that to maximize performance gain provided by ProxyCoop transmission and to minimize cost of ProxyCoopSetup, channel quality and channel availability of the proxy path and direct path must be concerned in the relay selection method.

For the administrative (routing) performance comparison in term of NRDM per second, the NRDMs per second of ProxyCoop transmissions with and without ProxyCoopSetup are very similar. Thus, we can conclude that ProxyCoopSetup does not have any impacts to the NRDM. The NRDM per second is only a function of channel quality of the direct path and proxy paths.

Finally, when the implementation of the proxy cooperative communication and how it can be integrated on existing networks have been considered, it is shown that the design of proxy cooperative communication is also valuable for the 802.11s WLAN Mesh Network environments.

Conclusion

Researches in cooperative communication can be categorized into two major fields: cooperative transmissions and cooperative setup. Cooperative transmissions concern with transmission methods in the physical layer while cooperative setup consider how cooperative transmissions can interact with protocols in higher layers (especially in the MAC layer and the network layer) in order to implement resource allocation and relay selection methods, for instance. However, a common framework for cooperative communication comparisons and designs does not exist yet. Thus, we propose an original framework of a cooperative network at the system level called “**Cooperative Network Model**” to represent interaction of the protocol level in the cooperative transmission and the cooperative setup. The interest of the model is that it does not reflect the protocol layering; therefore, it can be generally used to analyse, compare, and design cooperation processes in cooperative protocols.

Then, we use the cooperative network protocol to design a cooperative transmission method called “**Proxy Cooperative Transmission (ProxyCoop)**”. The advantage of the proposed protocol is that, in contrast to other adaptive cooperative transmission methods, ProxyCoop can compatibly work with the IEEE 802.11 medium access method in both of the basic mode and the optional mode. From simulation results, it shows that the transmission performance of ProxyCoop transmission (evaluated by PDR and NRDM per second) outperforms that of non-cooperative transmissions when channel distributions of the direct path can cause multi-hop mode transitions in non-cooperative transmissions and a “good” relay is selected. A good relay means a relay terminal located in transmission ranges of the source and the destination terminal. In addition, its cooperative multi-hop path must have high channel quality and high channel availability than the direct path.

For cooperative setup design, we proposed a cooperative setup protocol named “**Proxy Cooperative Setup (ProxyCoopSetup)**”. The objective is to set up a cooperative network, which allows the implementation of ProxyCoop transmission in real networks. The proposition is done based on AODV routing protocol that is an IETF standard protocol, so that the proposition could be easily deployed. The costs of ProxyCoopSetup when it works with ProxyCoop transmissions are studied in terms of PDR and NRDM per second. From simulation results, the NRDMs per second of ProxyCoop transmissions with and without ProxyCoopSetup are very similar. Thus, we can conclude that ProxyCoopSetup does not have any impacts to the NRDM of the system. For the impact

in term of PDR, ProxyCoopSetup causes a reduction of PDR when it is applied in ProxyCoop transmissions since it gains processing delay and consumes resource of the systems. However, the reduction of the PDR in ProxyCoop transmission with ProxyCoopSetup is very slightly compared to the PDR in ProxyCoop transmission without ProxyCoopSetup. The ProxyCoop transmission with ProxyCoopSetup is able to exhibit the same performance in terms of PDR as the ProxyCoop transmissions without ProxyCoopSetup.

At the end of the thesis, the implementation of the proxy cooperative communication to existing networks is considered. A WLAN Mesh Network is chosen as an example of existing networks. It shows that the design of proxy cooperative communication is also valuable for the 802.11s WLAN Mesh Network environments.

Future works

It appears that cooperative transmissions are strongly influenced by the channel quality. To acquire the probabilities of frame errors is a complicated process since it is a statistic process and its value depends on signal processing methods at the physical layer such as multiplexing and coding methods. In this work, we have connected the channel quality and the frame loss rate in a simple way, by working with two probabilities (P1 and P2). Meanwhile, a more realistic model has to be studied in order to obtain more realistic evaluations.

Furthermore, an efficient way to compute the channel quality at the terminal has to be studied in order to achieve the adaptation process, which switches the system transmission mode from a proxy cooperative mode to a non-cooperative mode. For the probability of multi-hop mode transition, the system should be able to estimate channel distributions of the direct path whether it can cause multi-hop mode transitions in non-cooperative transmission or not. This study relates to channel estimation researches.

Acronymes

A.

ACK:	Acknowledgement
ACR:	Ad Hoc Cooperative Routing Algorithm Based on Optimal Channel Selection
AF:	Amplify-and-Forward
AODV:	Ad hoc On-Demand Distance Vector
AP:	Access Point
ARP:	Address Resolution Protocol
ARQ:	Automatic Repeat reQuest
AWGN:	Additive White Gaussian Noise

B.

BER:	Bit Error Rate
BPSK:	Binary Phase Shift Keying
BSS:	Basic Service Set

C.

CBR:	Constant Bit Rate
CDMA:	Code Division Multiple Access
CFC:	Claim for Cooperation
CoI:	Cooperative Information
CoopMAC:	Cooperative MAC for Wireless LANs
CRC:	Cyclic Redundancy Check
CSI:	Channel State Information
CSMA/CA:	Carrier Sense Multiple Access with Collision Avoidance
CTR:	Clear-To-Receive
CTS:	Clear To Send

D.

DBT:	Defer Backoff Time
DCF:	Distributed Coordinate Function
DCM:	Distributed Cooperative MAC for Multihop Wireless Networks
DF:	Decode-and-Forward
DIFS:	Distributed Inter Frame Space
DP:	Data Processing
DSR:	Dynamic Source Routing
DSDV:	Destination-Sequenced Distance-Vector

E.	
EGC:	Equal Gain Combining
F.	
FH:	Frequency Hopping
FIFO:	First-In First-Out
H.	
HARQ:	Hybrid Automatic Repeat request
HI:	Helper Indicator
HTS:	Helper Ready to Send
HWMP:	Hybrid Wireless Mesh Protocol
I.	
IETF:	Internet Engineering Task Force
IP:	Internet Protocol
ITU:	International Telecommunication Union
M.	
MAC:	Medium Access Control
MANET:	Mobile Ad hoc Network
MAP:	Mesh Access Point
MIMO:	Multiple-Input Multiple-Output
MRC:	Maximum Ratio Combiner
MP:	Mesh Point
MPP:	Mesh Portal
N.	
NACK:	Negative Acknowledgement
NAV:	Network Allocation Vector
NRDM:	Number of Route Discovery and Maintenance
O.	
OFDM:	Orthogonal Frequency-Division Multiplexing
OSI:	Open Systems Interconnection
P.	
PCF:	Point Coordinate Function
PDR:	Packet Delivery Ratio
PLCP:	Physical Layer Convergence Protocol
ProxyCoop:	Proxy Cooperative Transmission
ProxyCoopSetup:	Proxy Cooperative Setup
PRT:	Potential Relay Terminal

PSTN: Public Switched Telephone Network

R.

Re-Tx_{Direct}: Re-Transmission counter in the Direct path

ReRE: Relay Request Packet

ReREP: Relay Reply Packet

RREP: Route Reply

RREQ: Route Request

RTH: Ready-To-Help

RTS: Request To Send

RTS/CTS: Ready-to-Send/Clear-To-Send

S.

SC: Selection Combining

SIFS: Short Inter Frame Space

SIMO: Single Input Multiple Output

SISO: Single Input Single Output

SNR: Signal to Noise Ratio

STA: Station

STC: Space Time Code

T.

TDD: Time-Division Duplex

TTL: Time To Live

U.

UDP: User Datagram Protocol

W.

WLAN: Wireless Local Area Network

WMN: WLAN Mesh Network

Bibliographies

- [ACLY00] R. Ahlswede, N. Cai, S.Y. R. Li, and R. W. Yeung, "Network Information Flow," *IEEE Trans. on Info. Theory*, vol. 46, no. 4, pp. 1204-1216, July 2000.
- [AzAA05] A. Azgin, Y. Altunbasak, and G. AlRegib, "Cooperative MAC and routing protocols for wireless ad hoc networks," in *Proc. IEEE GLOBECOM'05*, Nov. 2005, pp. 2854-2859.
- [BCGH06] J. Luo, R.S. Blum, L. Cimini, L. Greenstein, and A. Haimovich, "Power allocation in a transmit diversity system with mean channel gain Information," *IEEE Commun. Lett.*, vol. 9, pp. 616-618, Jul. 2005.
- [BISW07] A. Bletsas, H. Shin, and M. Z. Win, "Cooperative communications with outage-optimal opportunistic relaying," *IEEE Trans. Wireless Comm.*, vol. 6, no. 9, pp.3450-3460. Sept. 2007.
- [BoFY04] J. Boyer, D. D. Falconer, and H. Yanikomeroglu, "Multihop diversity in wireless relaying channels," *IEEE Trans. Commun.*, vol. 52, no. 10, pp. 1820-1830, Oct. 2004.
- [BrCG01] R. Brubo, M. Conti, and E. Gregori, "WLAN technologies for mobile ad hoc networks," in *Proc. IEEE HICSS-34'01*, Jan. 2001, pp. 1-11.
- [ChCY08] W. Cho, R. Cao, and L. Yang, "Optimum Resource Allocation for Amplify-and-Forward Relay Networks With Differential Modulation," *IEEE Trans. Signal Proc.*, vol. 56, no. 11, pp. 5680-5691, Nov. 2008.
- [ChYW07] C. Chou, J. Yang, D. Wang, "Cooperative MAC protocol with automatic relay selection in distributed wireless networks", in *Proc. IEEE PerComW'07*, Mar. 2007, pp. 1-6.
- [ChZZ06] C.Chen, B. Zheng, and X. Zhao, "An ad hoc cooperative routing algorithm based on optimal channel selection," in *Proc. IEEE ICWMMN'06*, Nov. 2006, pp. 1-4.
- [CZZY07] C. Chen, B. Zheng, X. Zhao, and Z. Yan, "A novel weighted cooperative routing algorithm based on distributed relay selection," in *Proc. of IEEE ISWPC'07*, Feb. 2007, pp. 224 229.
- [DiRL09] Z. Ding, T. Ratnarajah, and K. K. Leung, "On the study of network coded AF transmission protocol for wireless multiple access channels," *IEEE Trans. Wireless Comm.*, vol. 8, no. 1, pp. 118-123, Jan. 2009.
- [EPRP08] B. Escrig, B. Paillasa, D. Roviras, and W. Panichpattanakul, "A framework for cooperative communications at the system level," in *Proc. IEEE MASS'08*, Sept. 2008, pp. 653-658.

- [FoGa98] G. J. Foschini and M. J. Gans, "On limits of wireless communications in a fading environment when using multiple antennas," *Wireless Personal Communications Magazine*, vol. 6, no. 3, pp. 311-335, Mar. 1998.
- [GuDC09] B. Gui, L. Dai, and L. J. Cimini Jr., "Routing strategies in multihop cooperative networks," *IEEE Trans. Wireless Commun.*, vol. 8, no. 2, pp.843-855, Feb. 2009.
- [GZVP07] J. Gomez, J. Alonso-Zarate, C. Verikoukis, A. I. Perez-Neira, and L. Alonso, "Cooperation on demand protocols for wireless networks," in *Proc. IEEE PIMRC'07*, Sept. 2007, pp. 1-5.
- [HuNo06] T. E. Hunter and A. Nosratinia, "Diversity through coded cooperation," *IEEE Trans. Wireless Commun.*, vol. 5, no. 2, pp. 283-289, Feb. 2006.
- [HuZN09] Y. Hua, Q. Zhang, and Z. Niu, "A cooperative MAC protocol with virtual-antenna array support in a multi-AP WLAN system," *IEEE Trans. Wireless Commun.*, vol. 8, no. 9, pp. 4086-4814, Sept. 2009.
- [IbHL07] [A. S. Ibrahim, Z Han. K. J. R. Liu, "Distributed Energy-Efficient Cooperative Routing in Wireless Networks," in *Proc. IEEE GLOBECOM '07*, Nov. 2007, pp. 4413-4418.
- [IEEE07] IEEE Standard for Information Technology-Part 11: Wireless LAN Medium Access Control (MAC) and Physical Layer (PHY) Specifications Issue, June 2007, <<http://ieeexplore.ieee.org/servlet/opac?punumber=4248376>> 25.08.2010.
- [Ilya03] M. Ilyas, "The Handbook of Ad Hoc Wireless Networks," CRC press LLC, 2003.
- [IsKr09] T. Issariyakul and V. Krishnamurthy, "Amplify-and-forward cooperative diversity wireless networks: model, analysis, and monotonicity properties," *IEEE/ACM Trans. Networking*, vol. 17, no.1, pp.225-238, Feb. 2009.
- [ISSL05] A. S. Ibrahim, A. k. Sadek, W. Su, and K. J. R. Liu, "Cooperative communications with partial channel state information: When to cooperate?," in *Proc. IEEE GLOBECOM '05*, Nov. 2005, vol. 5, pp. 3068-3072.
- [JHHN04] M. Jananai, A. Hedayat, T. E. Hunter, and A. Nosratinia, "Coded cooperation in wireless communications: Space-time transmission and iterative decoding," *IEEE Trans. Signal Processing*, vol.52, no. 2, pp.362-370, Feb. 2004.
- [JLLC09] E. W. Jang, L. Jungwon, L. H. Lou, J. M. Cioffi, "On the combining schemes for MIMO systems with hybrid ARQ," *IEEE Trans. Wireless Commun.*, vol. 8, no. 2, pp. 836-842, Feb. 2009.
- [JKFK07] G. Jakllari, S. V. Krishnamurthy, M. Faloutsos, P. V. Krishnamurthy, O. Ercetin, "A cross-layer framework for exploiting virtual MISO links in mobile ad hoc networks," *IEEE Trans. Mobile Computing*, vol. 6, no. 6, pp. 579-594, Jun. 2007.

- [JoMa96] D. B. Johnson and D. A. Maltz, "Dynamic source routing in ad hoc wireless networks," *Mobile computing edited by Tomasz Imielinski and Henry F. Korth, Kluwer Academic Publishers*, pp. 153-181, March 1996.
- [KAMZ07] A. E. Khandani, J. Abounadi, E. Modiano, and L. Zheng, "Cooperative routing in static wireless networks," *IEEE Trans. Commun.*, vol. 55, no. 11, pp. 2185-2192, Nov. 2007.
- [KNBP06] T. Korakis, S. Narayanan, A. Bagri, and S. Panwar, "Implementing a Cooperative MAC Protocol for Wireless LANs," in *Proc. IEEE ICC '06*, June 2006, pp. 4805-4810.
- [Lane02] J. N. Laneman, "Cooperative diversity in wireless networks: Algorithms and architectures," *Ph.D. thesis*, M.I.T., Cambridge, MA, Aug. 2002.
- [LaTW04] J. N. Laneman, D. N. C. Tse, and G. W. Wornell, "Cooperative diversity in wireless networks: Efficient protocols and outage behavior," *IEEE Trans. Inform. Theory*, vol. 50, no. 12, pp. 3062-3080, Dec. 2004.
- [LaWo03] J. N. Laneman and G. W. Wornell, "Distributed space-time-coded protocols for exploiting cooperative diversity in wireless networks," *IEEE Trans. Inform. Theory*, vol. 49, no. 10, pp. 2415-2425, Oct. 2003.
- [LiSS08] R. Liu, P. Spasojevic, and E. Soljanin, "Incremental redundancy cooperative coding for wireless networks: Cooperative diversity, coding, and transmission energy gains," *IEEE Trans. Info. Theory*, vol. 54, no. 3, pp. 1207-1220, March 2008.
- [LiTP05] P. Liu; Z. Tao, and S. Panwar, "A cooperative MAC protocol for wireless local area networks" in *Proc. IEEE ICC'05*, May 2005, pp. 2962-2968.
- [LTNK07] P. Liu, Z. Tao, S. Narayanan, T. Korakis, and S. S. Panwar, "CoopMAC: A cooperative MAC for wireless LANs" *IEEE J. Select. Areas Commun.*, vol. 25, no. 2, pp.340-354, Feb. 2007.
- [MeMe09] G. D. Menghwar and C. F. Mecklenbrauker, "Outage performance of two users cooperative network coding," in *Proc. IEEE ISCIT'09*, Sept. 2009, pp.1180-1184.
- [MMMZ09] R. Madan, N. B. Mehta, A. F. Molisch, and J. Zhang, "Energy-efficient decentralized cooperative routing in wireless networks," *IEEE Trans. Automatic Control*, vol. 54, no. 3, pp.512-527, March 2009.
- [NeSi10] The Network Simulator (NS2), <<http://www.isi.edu/nsnam/ns/>> 25.08.2010.
- [NoHu04] A. Nosratinia, T. E. Hunter and A. Hedayat, "Cooperative communication in wireless networks," *IEEE Communications Magazine*, vol. 42, pp. 74-80, Oct. 2004.
- [NiQB06] A. R. Nigara, M. Qin, and R. S. Blum, "On the performance of wireless ad hoc networks using amplify-and-forward cooperative diversity," *IEEE Trans. Wireless Comm.*, vol. 5, no. 11, pp. 3204-3214, Nov. 2006.
- [ODHJ03] E. N. Onggosanusi, A. G. Dabak, Y. Hui, and G. Jeong, "Hybrid ARQ transmission and combining for MIMO systems," in *Proc. IEEE ICC '03*. vol. 5, pp. 3205-3209, May 2003.

- [PeBh94] C. Perkins and P. Bhagwat, "Highly dynamic destination-sequenced distance-vector (DSDV) for mobile computers," in *Proc. ACM SIGCOMM'94*, Aug. 1994, pp. 1-11.
- [PeFL08] M. V. Pedersen and F.H.P. Fitzek, "Implementation and performance evaluation of network coding for cooperative mobile devices," in *Proc. IEEE ICC'08*, May 2008, pp.91-96.
- [PeRD03] C. Perkins, E. B. Royer, and S. Das. "Ad hoc On-Demand Distance Vector (AODV) Routing," RFC 3561, *IETF Network Working Group*, July 2003.
- [Plum98] D. C. Plummer, "An Ethernet Address Resolution Protocol," RFC 826, <<http://www.ietf.org/rfc/rfc826.txt>>, 25.08.2010.
- [PPER09] W. Panichpattanakul, B. Paillassa, B. Escrig, and D. Roviras, "A proxy cooperative diversity method based on IEEE802.11 standards," in *Proc. IEEE IWCMC'08*, Jun. 2009, pp. 1-5.
- [Proa95] J. G. Proakis, *Digital Communications*, 3rd ed. New York: McGraw-Hill, 1995.
- [PWSF04] R. Pabst, B. H. Walke, D. C. Schultz, and P. Herhold, "Relay-based deployment concepts for wireless and mobile broadband radio," *IEEE Commun. Magazine*, vol. 42, pp. 80-89, Sept. 2004.
- [SeEA03a] A. Sendonaris, E. Erkip and B. Aazhang, "User cooperation diversity-Part I: System Description," *IEEE Trans. Commun.*, vol. 51, no. 11, pp. 1927-1938, Nov. 2003.
- [SeEA03b] —, "User cooperation diversity-Part II: Implementation aspects and performance analysis," *IEEE Trans. Commun.*, vol. 51, no. 11, pp. 1939-1948, Nov. 2003.
- [ShZW09] H. Shan, W. Zhuang, Z. Wang, "Distributed cooperative MAC for multihop wireless networks," *IEEE Commun. Magazine*, vol. 47, no. 2, pp. 126-133, Feb. 2009.
- [SMTE07] Y. Sung, S. Misra, L. Tong, and A. Ephremides, "Cooperative routing for distributed detection in large sensor networks," *IEEE J. Select. Areas Commun.*, vol. 25, no. 2, pp. 471-483, Feb. 2007.
- [StEr04] A. Stefanov and E. Erkip, "Cooperative Coding for Wireless Networks," *IEEE Trans. Commun.*, vol. 52, no. 9, pp. 1470-1476, Sept. 2004.
- [SuLW09] Y. Sun, Y. Li, and X. Wang, "Cooperative hybrid-ARQ protocol with network coding," in *Proc. IEEE ChinaCOM'09*. Aug. 2009, pp. 1-5.
- [Tela95] I. E. Telatar, "Capacity of multi-antenna Gaussian Channels," *European Trans. on Telecomm.*, vol. 10, no. 6, pp. 585-595, Nov.-Dec. 1999.
- [WaLW09] L. C. Wang, W. C. Liu, and S. H. Wu, "Diversity-multiplexing tradeoff analysis of a cooperative network coding system," in *Proc. IEEE SARNOFF '09*, April 2009. pp. 1-5.
- [WHLP08] Y. Wang, C. Hu, H. Liu, M. Peng, and W. Wang, "Network coding in cooperative relay networks," in *Proc. IEEE PIMRC'08*, Sept. 2008, pp.1-5.

- [YaLH05] Z. Yang, J. Liu, and A. Host-Madsen, "Cooperative routing and power allocation in ad hoc networks," in *Proc. IEEE GLOBECOM'05*, Nov. 2005, pp. 2730-2734.
- [ZhCa06] H. Zhu, G. Cao, "rDCF: A Relay-Enabled Medium Access Control Protocol for Wireless Ad Hoc Networks," *IEEE Trans. Mobile Computing*, vol. 5, no. 9, pp. 1201-1214, July 2006.
- [ZhCi08] L. Zhang and L. J. Cimini, "Cooperative network coding in selective decode-and-forward networks with multiple source-destination pairs," in *Proc. IEEE CISS'08*, Mar. 2008, pp. 521-526.
- [ZhJZ09] Q. Zhang, J. Jia, and J. Zhang, "Cooperative relay to improve diversity in cognitive radio networks," *IEEE Communications Magazine*, vol. 47, no. 2, pp. 111-117, Feb. 2009.
- [ZhZJ09] J. Zhang, Q. Zhang, and W. Jia, "VC-MAC: A cooperative MAC protocol in Vehicular Networks," *IEEE Trans. Veh. Tech.*, vol. 58, no. 3, pp. 1561 – 1571, March 2009.
- [ZoRo03a] M. Zorzi, R. R. Rao, "Geographic random forwarding (GeRaF) for ad hoc and sensor networks: multihop performance," *IEEE Trans. Mobile Computing*, vol. 2, no. 4, pp. 337-348, Oct.-Dec. 2003.
- [ZoRo03b] —, "Geographic random forwarding (GeRaF) for ad hoc and sensor networks: energy and latency performance," *IEEE Trans. Mobile Computing*, vol. 2, no. 4, pp. 349-365, Oct.-Dec. 2003.

Résumé :

Les techniques de communication coopératives ont été proposées pour améliorer la qualité des signaux reçus par les terminaux sans fil grâce au principe de diversité spatiale. Cette propriété est obtenue par une duplication du signal, envoyé par l'émetteur au niveau d'un terminal relais situé entre l'émetteur et le récepteur. Les travaux de recherche menés en communications coopératives concernent deux domaines principaux: certains traitent la transmission physique alors que d'autres sont étudier l'interaction de la couche physique avec les couches protocolaires supérieures, en particulier les niveaux MAC (Medium Access Control) et réseau. Si ces domaines de recherche sont généralement séparés, des études conjointes s'avèrent nécessaires pour obtenir des systèmes coopératifs implantables. C'est dans ce contexte que se situent les travaux de la thèse avec, comme cadre applicatif, les réseaux ad hoc.

En premier lieu, dans la mesure où il n'existe pas de modèle complet de système coopératif, un cadre de modélisation original est proposé pour représenter le fonctionnement d'un système coopératif, sa mise en place et son fonctionnement. Une caractéristique du modèle est de faire abstraction des couches protocolaires. Cette façon de procéder permet d'analyser de façon similaire différentes solutions proposées dans la littérature. De plus, ce modèle facilite la conception de solutions coopératives, en particulier la conception du processus de mise en place du système de coopération qui initialise les rôles de relais, destinataire et source en fonctionnement coopératif.

Le modèle de système coopératif est utilisé pour la conception d'une solution de transmission coopérative adaptative où le relais agit en tant que proxy entre la source et le destinataire. L'intérêt de notre proposition, ProxyCoop, par rapport à d'autres propositions, est d'être compatible avec le protocole IEEE 802.11 que ce soit dans son mode de base ou dans son mode optionnel. Pour chaque trame, le mode de transmission à la source est dynamiquement défini soit en mode proxy coopératif soit en mode non coopératif, et ce en fonction de la réception ou la non réception d'un acquittement du destinataire. Les résultats de simulation montrent, sous certaines conditions, une amélioration des performances en termes de nombre de trames effectivement reçues. Le nombre de retransmissions dues à des trames reçues erronées est diminué, et les transmissions en mode multi saut, coûteuses en temps et en bande passante sont également diminuées. Les conditions favorables à la coopération sont dépendantes de la qualité et de l'accessibilité du canal. Une méthode pour la mise en place du système coopératif est également proposée. Elle repose sur l'utilisation d'un protocole standard de routage pour réseaux ad hoc, AODV. Les évaluations de performances indiquent que la mise en place du système de coopération coûte peu en termes de bande passante, les performances du système (mise en place et fonctionnement) sont supérieures à celles d'un système non-coopératif, pour des conditions données.

Finalement, l'application de la solution proposée à un réseau ad hoc spécifique, un réseau maillé (mesh) conforme au standard IEEE 802.11s illustre où et comment déployer la solution proposée.

Mots clés: Coopération, réseaux ad hoc, adaptation, IEEE 802.11, AODV.