



**HAL**  
open science

# A life cycle assessment and process system engineering integrated approach for sustainability: application to environmental evaluation of biofuel production

Sayed Tamiz Ud Din Gillani

## ► To cite this version:

Sayed Tamiz Ud Din Gillani. A life cycle assessment and process system engineering integrated approach for sustainability: application to environmental evaluation of biofuel production. Chemical and Process Engineering. Institut National Polytechnique de Toulouse - INPT, 2013. English. NNT : 2013INPT0069 . tel-04289587

**HAL Id: tel-04289587**

**<https://theses.hal.science/tel-04289587v1>**

Submitted on 16 Nov 2023

**HAL** is a multi-disciplinary open access archive for the deposit and dissemination of scientific research documents, whether they are published or not. The documents may come from teaching and research institutions in France or abroad, or from public or private research centers.

L'archive ouverte pluridisciplinaire **HAL**, est destinée au dépôt et à la diffusion de documents scientifiques de niveau recherche, publiés ou non, émanant des établissements d'enseignement et de recherche français ou étrangers, des laboratoires publics ou privés.

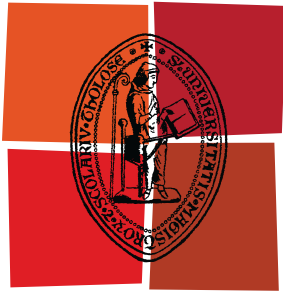

Université  
de Toulouse

# THÈSE

En vue de l'obtention du  
**DOCTORAT DE L'UNIVERSITÉ DE TOULOUSE**

**Délivré par :**  
Institut National Polytechnique de Toulouse (INP Toulouse)

**Discipline ou spécialité :**  
Génie Industriel

---

**Présentée et soutenue par :**  
Sayed Tamiz ud din GILLANI

**le :** jeudi 26 septembre 2013

**Titre :**  
A life cycle assessment and process system engineering integrated approach  
for sustainability: application to environmental evaluation of biofuel  
production

---

**Ecole doctorale :**  
Systèmes (EDSYS)

**Unité de recherche :**  
Laboratoire de Génie Chimique, UMR 5503

**Directeur(s) de Thèse :**  
Pr. Jean-Marc LE LANN  
Dr. Mireille VIGNOLES

**Rapporteurs :**  
Pr. Jean-Marc ENGASSER  
Pr. Nicolas PERRY

**Membre(s) du jury :**  
Pr. Jean-Marc LE LANN  
Dr. Mireille VIGNOLES  
Dr. Sébastien LEFEVRE  
Pr. Carlos VACA-GARCIA  
Pr. Jean-Marc ENGASSER  
Pr. Nicolas PERRY

---

## Summary

---

***Title: A life cycle assessment and process system engineering integrated approach for sustainability: application to environmental evaluation of biofuel production***

With the rise of global warming issues due to the increase of the greenhouse gas emission and more generally with growing importance granted to sustainable development, process system engineering (PSE) has turned to think more and more environmentally. Indeed, the chemical engineer has now taken into account not only the economic criteria of the process, but also its environmental and social performances. On the other hand LCA is a method used to evaluate the potential impacts on the environment of a product, process, or activity throughout its life cycle. The research here focused on coupling of PSE domain with the environmental analysis of agricultural and chemical activities and abatement strategies for agro-processes with the help of computer aided tools and models. Among many approaches, the coupling of PSE and LCA is investigated here because it is viewed as a good instrument to evaluate the environmental performance of different unitary processes and whole process. The coupling can be of different nature depending on the focus of the study. The main objective is to define an innovative LCA based on approach for a deep integration of product, process and system perspectives. We selected a PSE embedded LCA and proposed a framework that would lead to an improved eco-analysis, eco-design and eco-decision of business processes and resulted products for researchers and engineers.

In the first place we evaluate biodiesel for environmental analysis with the help of field data, background data and impact methodologies. Through this environmental evaluation, we identify the hotspot in the whole production system. To complement the experimental data this hotspot (i.e. transesterification) is selected for further modeling and simulation. For results validation, we also implement LCA in a dedicated tool (SimaPro) and simulation in a PSE simulation tool (Prosim Plus). Finally we develop a tool (SimLCA) dedicated to the LCA by using

PSE tools and methodologies. This development of SimLCA framework can serve as a step forward for determination of sustainability and eco-efficient designing.

**Key-words:** Sustainability, Agro-chemical processes, Life Cycle Assessment, Process System Engineering, Biofuel, Simulation based environmental analysis, Transesterification

---

## Résumé

---

***Titre : L'approche intégrée de analyse cycle de vie et génie des procédés pour soutenabilité: application à l'évaluation environnementale du système de production de biocarburants***

La méthode de l'Analyse du Cycle de Vie (ACV) est devenue ces dernières années un outil d'aide à la décision « environnementale » pour évaluer l'impact des produits et des processus associés. La pratique de l'ACV est documentée comme un outil pour l'évaluation d'impacts, la comparaison et la prise de décisions « orientée produit ». L'exploitation d'une telle méthode pour les procédés de l'industrie bio-physico-chimique a gagné récemment en popularité. Il existe de nombreux faisceaux d'amélioration et d'expansion pour sa mise en œuvre pour l'évaluation des procédés industriels. L'étude s'attache à la production de biocarburant à partir de la plante *Jatropha curcas* L. selon une approche « attributionnelle ». Cette étude présente l'évaluation environnementale d'un agro-procédé et discute de l'opportunité de coupler les concepts, les méthodes et les outils de l'ACV et de l'IPAO (Ingénierie des Procédés Assistés par Ordinateur).

Une première partie présente l'ACV appliquée à l'agrochimie. L'état de la littérature apporte des enseignements sur les diverses études qui mettent en évidence le rôle et l'importance de l'ACV pour les produits et les différents agro-procédés. La substitution des carburants classiques par les biocarburants est considérée comme une voie potentielle de substitution aux énergies fossiles. Leur processus se doit d'être évalué au regard de l'impact environnemental et du paradigme du développement durable, en complément des critères classiques, économiques et politiques.

La deuxième partie aborde notre étude ACV de la production du biocarburant à partir de la plante *Jatropha*. Cette évaluation englobe la culture et la récolte en Afrique, l'extraction de l'huile et la phase de production de biocarburants, jusqu'à son utilisation par un moteur à explosion. À cet effet, les normes ISO 14040 et 14044 sont respectées. Basée sur une perspective « midpoint » avec les méthodes de calcul d'impacts, Impact 2002+ et CML, nous fournissons les premiers résultats de la phase d'interprétation (GES, appauvrissement des ressources, la couche d'ozone, l'eutrophisation et l'acidification). Cette étude démontre le potentiel de production de biocarburants de deuxième génération à réduire l'impact environnemental. Dans le même temps, elle révèle que l'unité de transesterification est le plus impactant. Nous identifions les limites de notre application selon une approche ACV « pure ».

Dans la troisième partie, nous discutons des bénéfices attendus du couplage de l'ACV et des méthodes de modélisation et de simulation de l'ingénierie des procédés. Nous suggérons alors une amélioration de l'approche environnementale des systèmes de production. Nous

fournissons un cadre de travail intégrant les différents points de vue, système, processus et procédé afin d'évaluer les performances environnementales du produit. Un outil logiciel, SimLCA, est développé sur la base de l'environnement Excel et est validé par l'utilisation de la solution ACV SimaPro et du simulateur de procédés Prosim Plus. SimLCA permet un couplage ACV-simulation pour l'évaluation environnementale du système complet de production de biocarburant. Cette intégration multi-niveaux permet une interaction dynamique des données, paramètres et résultats de simulation. Différentes configurations et scénarios sont discutés afin d'étudier l'influence de l'unité fonctionnelle et d'un paramètre de procédé.

La quatrième partie établit la conclusion générale et trace les perspectives.

**Mots-clés:** Durabilité, procédé agro-chimique, Analyse de cycle de vie, Ingénierie des procédés, Biocarburant, Analyse environnementale par la simulation, Transesterification.

---

## Acknowledgements

---

A l'issue de la rédaction de cette recherche, je suis convaincue que la thèse est loin d'être un travail solitaire. En effet, je n'aurais jamais pu réaliser ce travail doctoral sans le soutien d'un grand nombre de personnes dont la générosité, la bonne humeur et l'intérêt manifestés à l'égard de ma recherche m'ont permis de progresser dans cette phase délicate de « l'apprenti chercheur ».

Ce travail de thèse a été réalisé sous la direction de Jean-Marc LE LANN et Mireille VIGNOLES, merci de m'avoir accueillie au sein du Laboratoire de Génie Chimique et Laboratoire de Chimie Agro-Industrielle à l'Ensiacet.

Je remercie Caroline SABLAYROLLES et Jean-Pierre BELAUD d'avoir pensé ce projet original et pluridisciplinaire. Je tiens à les remercier pour m'avoir fait confiance, pour m'avoir soutenue et pour avoir été disponibles tout au long de ces quatre années.

Je remercie mes rapporteurs, Professeur. Jean-Marc ENGASSER et Professeur. Nicolas PERRY, pour l'intérêt qu'ils ont porté à mes travaux. Je remercie également les membres du Jury, Professeur. Carlos VACA-GARCIA et Docteur. Sébastien LEFEVRE, qui m'a fait l'honneur de discuter de mes travaux.

Je remercie également tous les collègues du labo, exprimer ma reconnaissance à tout le département PSI et plus particulièrement aux doctorants de la rue 3. Grâce à la bonne humeur et l'entraide qui règnent au sein de ce groupe, cela a été un réel plaisir de venir travailler tous les jours. Guillaume BUSSET, mon partenaire ACViste, merci pour ton oreille toujours attentive et ces moments de partage, je souhaite qu'il y en ait beaucoup d'autres, aujourd'hui, je suis très heureuse d'avoir bénéficié de tes conseils et encouragements.

Merci à mes stagiaires Benjamin CANON, Clément DOUSSET, David GRASSIN, Marion DUMAINE et Laura FROMAGE avec qui j'ai travaillé en étroite bibliographique.

J'exprime ma gratitude à tous les amis Pakistanaises Najma AZMAT, Abid ASLAM, Inam SADDZOAI, Manzoor AHMAD, Kamran LALA, Muazzam GHOUS, Ayesha ANJUM et Ali NIZAMANI, Merci bien !

En dernier lieu, je souhaite remercier ma famille et toute ses « valeurs ajoutées » et assimilées pour leur inconditionnel soutien. Avec vous, j'ai découvert les plaisirs d'une famille (toujours plus) nombreuse. C'est un ravissement ! Merci à mes parents, ma « petit Rayan » (The SpiderMan), et mes frères (Asif SHAH et Tauseef Alam) sœur (Noshi GILLANI), mon cousin (Nafees BACHA), tout simplement.

Je termine en remerciant ma femme NOSHEEN pour son soutien affectif et pour ses encouragements continus, qui m'ont aidée à maintenir le cap et à surmonter les moments difficiles.





---

## Table of Contents

---

<b>A. SCIENTIFIC CONTEXT AND STATE OF THE ART .....</b>	<b>19</b>
<b>1. INTRODUCTION .....</b>	<b>23</b>
1.1 RESEARCH CONTEXT.....	24
1.2 DISSERTATION STRUCTURE, PLAN AND PROPOSED TASKS .....	27
<b>2. SUSTAINABILITY THROUGH LIFE CYCLE THINKING .....</b>	<b>29</b>
2.1 LIFE CYCLE THINKING FOR SUSTAINABILITY.....	30
2.1.1 Life Cycle Thinking and Sustainability .....	30
2.1.2 Sustainability of biofuels through life cycle thinking.....	34
2.2 LIFE CYCLE ASSESSMENT.....	39
2.2.1 Introduction to life cycle assessment .....	39
2.2.2 Background of LCA .....	41
2.2.3 LCA for Biodiesel.....	42
2.2.4 Different approaches towards LCA.....	44
2.2.5 Sustainability through LCA .....	46
2.3 PROCESS SYSTEM ENGINEERING AND SUSTAINABILITY.....	47
<b>3. DEFINITION AND HISTORICAL BACKGROUND OF BIOFUELS .....</b>	<b>49</b>
3.1 PRESENT SCENE.....	50
3.2 BIRTH OF BIOFUELS.....	50
3.3 PRESENT SITUATION OF OIL PRODUCTION.....	51
3.3.1 Global situation .....	51
3.3.2 USA situation.....	52
3.3.3 Brazil Biofuel sector.....	53
3.3.4 Biofuel in European Union.....	53
3.3.5 French Biofuel production .....	54
3.4 DIFFERENT TECHNIQUES OF BIOFUELS .....	54
3.4.1 Bioenergy .....	54
3.4.2 Renewable.....	55
3.4.3 Biofuels.....	55
3.5 CURRENT BIOFUEL ISSUES .....	57

3.5.1	<i>Environmental issues</i> .....	57
3.5.2	<i>Socio-economic issues</i> .....	59
3.5.3	<i>Geostrategic issues</i> .....	61
<b>4.</b>	<b>JATROPHA OVERVIEW FOR BIODIESEL PRODUCTION</b> .....	<b>63</b>
4.1	<i>JATROPHA OVERVIEW</i> .....	64
4.1.1	<i>Cultivation</i> .....	65
4.1.2	<i>Global production of Jatropha</i> .....	66
4.1.3	<i>Botanical description</i> .....	67
4.1.4	<i>Seed production</i> .....	67
4.2	<i>BIODIESEL PRODUCTION FROM JATROPHA</i> .....	68
4.2.1	<i>Transesterification process</i> .....	70
4.2.2	<i>Jatropha Transesterification process</i> .....	73
4.3	<i>CRITICS OF JATROPHA</i> .....	74
4.3.1	<i>Competition with food product</i> .....	74
4.3.2	<i>Economic viability for commercial plantation of Jatropha</i> .....	75
4.3.3	<i>Impact on the environment and human health</i> .....	75
<b>5.</b>	<b>CONCLUSION AND RESEARCH OBJECTIVES</b> .....	<b>77</b>
5.1	<i>SUMMARY OF PART A</i> .....	78
5.2	<i>RESEARCH QUESTIONS INCURRED</i> .....	78
<b>B.</b>	<b>LIFE CYCLE ASSESSMENT OF JATROPHA BIODIESEL PRODUCTION SYSTEM</b> .....	<b>81</b>
<b>6.</b>	<b>METHODOLOGY OF LIFE CYCLE ASSESSMENT</b> .....	<b>85</b>
6.1	<i>GENERAL PRESENTATION</i> .....	86
6.1.1	<i>Goal and Scope Definition</i> .....	88
6.1.2	<i>Inventory Analysis phase</i> .....	88
6.1.3	<i>Impact Assessment phase</i> .....	89
6.1.4	<i>Interpretation phase</i> .....	92
6.2	<i>DATABASE FOR LCA</i> .....	92
6.3	<i>REVIEW OF LCA TOOLS</i> .....	94
<b>7.</b>	<b>LCA OF JATROPHA (A WEST AFRICAN CASE STUDY)</b> .....	<b>95</b>
7.1	<i>GENERAL PRESENTATION</i> .....	96
7.2	<i>GOAL AND SCOPE DEFINITION</i> .....	97
7.2.1	<i>Goal</i> .....	97

7.2.2	Functional unit.....	97
7.2.3	Process tree, boundaries and hypothesis.....	98
7.3	LIFE CYCLE INVENTORY.....	99
7.3.1	Cultivation of <i>Jatropha</i> and its management.....	99
7.3.2	Production of Biodiesel.....	101
7.3.3	Data collection .....	101
7.4	LIFE CYCLE IMPACT ANALYSIS.....	105
7.5	RESULTS.....	107
7.5.1	Midpoint evaluation.....	107
7.5.2	Damage evaluation.....	114
7.6	UNCERTAINTY ANALYSIS.....	116
7.7	DISCUSSION.....	122
7.7.1	Comparison of other studies .....	122
7.7.2	Choosing between LCIA methods.....	124
7.7.3	Comparison of results between SimaPro and Excel based LCA.....	125
<b>8.</b>	<b>EVALUATING THE LIMITS IDENTIFIED THROUGH LCA AND PROPOSED SOLUTION .....</b>	<b>127</b>
8.1	PSE METHODS AND TOOLS AS A POSSIBLE SOLUTION FOR LCA LIMITATIONS .....	128
8.2	LCA APPLICATION IN PROCESS DESIGN AND OPTIMIZATION .....	129
<b>C. FRAMEWORK FOR A PRODUCT AND PROCESS BASED ENVIRONMENTAL EVALUATION..... 133</b>		
<b>9.</b>	<b>PROPOSAL FOR COUPLING PSE AND LCA.....</b>	<b>137</b>
9.1	PROCESS SYSTEM ENGINEERING AND ITS ROLE IN ENVIRONMENTAL EVALUATION AND ECO-DESIGNING.....	138
9.1.1	Process model for biodiesel production .....	140
9.1.2	Process simulation for biodiesel production .....	141
9.1.3	Process optimization for biodiesel production.....	142
9.2	THE PSE AND LCA COUPLING.....	144
9.2.1	PSE embedded LCA.....	144
9.2.2	LCA embedded PSE.....	146
9.3	PROPOSAL FOR THE PRESENT WORK.....	147
9.3.1	Decision making process by environmental evaluation .....	147
9.3.2	Description of activities.....	150
9.3.3	Typology of messages .....	152
<b>10.</b>	<b>SIMULATION OF TRANSESTERIFICATION UNITARY PROCESS FOR PSE EMBEDDED LCA .....</b>	<b>155</b>

10.1	SUMMARY OF THE PROPOSED TASK .....	156
10.2	DESCRIPTION OF JATROPHA TRANSESTERIFICATION PROCESS.....	157
10.2.1	Simulation for unitary process of transesterification .....	158
10.2.2	Selected process description .....	158
10.2.3	Classic transesterification reaction .....	159
10.2.4	Process components.....	160
10.2.5	Different section of given apparatus.....	161
10.2.6	Thermodynamic model and kinetics of transesterification.....	161
10.3	GLOBAL APPROACH FOR EXCEL SIMULATOR.....	161
10.4	PROCESS SIMULATOR THROUGH PROSIM PLUS.....	166
10.4.1	From process continue to process discontinue.....	166
10.4.2	Thermodynamic model and components used .....	169
10.4.3	Critical comparison of Prosim Plus and Excel simulator results .....	172
<b>11.</b>	<b>SIMLCA FRAMEWORK FOR BIOFUEL PRODUCTION SYSTEM .....</b>	<b>175</b>
11.1	GENERAL STRUCTURE OF SIMLCA .....	176
11.2	INFORMATION FLOW OF SIMLCA.....	179
11.3	PRESENTATION OF SIMLCA.....	181
11.4	VALIDATION OF SIMLCA .....	183
11.5	MAIN INTEREST IN LCA AND PSE COUPLING.....	187
<b>12.</b>	<b>DISCUSSION AND ANALYSIS FROM SIMLCA .....</b>	<b>189</b>
12.1	ANALYSIS OF DIFFERENT SCENARIOS FROM SIMLCA .....	190
12.1.1	Results with coupling and without coupling (scenarios 1 & 3).....	191
12.1.2	Influence of conversion rate with two functional units (scenarios 2 & 3).....	193
12.1.3	Influence of un-entertained impacts (scenarios 4 & 5).....	195
12.2	CONCLUSION THANKS TO SIMLCA TOOL.....	196
12.3	CRITICAL COMPARISON WITH OTHER STUDIES.....	196
<b>D.</b>	<b>POSTSCRIPT .....</b>	<b>199</b>
<b>13.</b>	<b>CONCLUSION AND PERSPECTIVES .....</b>	<b>203</b>
<b>14.</b>	<b>BIBLIOGRAPHY.....</b>	<b>209</b>
<b>15.</b>	<b>APPENDIXES.....</b>	<b>221</b>
15.1	DIFFERENT GENERATIONS OF BIOFUELS .....	222

15.1.1	<i>First-generation biofuels</i> .....	222
15.1.2	<i>2nd generation biofuels</i> .....	226
15.1.3	<i>3rd Generation biofuels</i> .....	229
15.2	<i>IMPACT ASSESSMENT WITH CML 2 BASELINE</i> .....	231
15.3	<i>DETAILS STUDY OF TRANSESTERIFICATION PROCESS</i> .....	231
15.3.1	<i>Jatropha Transesterification</i> .....	231
15.3.2	<i>Transesterification Description</i> .....	234
15.3.3	<i>Overview of complete process</i> .....	235
15.3.4	<i>The reaction of Transesterification</i> .....	236
15.3.5	<i>Transesterification in biodiesel production</i> .....	238
15.3.6	<i>Process study</i> .....	242
15.3.7	<i>Study of homogeneous batch process</i> .....	248
15.4	<i>THERMODYNAMIC AND UNIT OPERATION MODEL</i> .....	254
15.4.1	<i>Different section of given apparatus</i> .....	255
15.4.2	<i>Separation of glycerin and methyl ester</i> .....	257
15.4.3	<i>Separation of Glycerin and free fatty acids</i> .....	258
15.4.4	<i>Distillation of glycerin</i> .....	258
15.5	<i>KINETICS OF TRANSESTERIFICATION</i> .....	258
15.5.1	<i>Kinetic model 1 (Om Tapanes et al., 2008)</i> .....	258
15.5.2	<i>Kinetic Model 2 (Jain and sharma, 2010)</i> .....	260
15.5.3	<i>Critical analysis of results</i> .....	262
15.6	<i>LIST OF PROCESS STREAMS</i> .....	263
15.7	<i>MULTIPLE SCREEN SHOTS OF SIMLCA</i> .....	265
15.8	<i>TABULATED RESULTS FROM SIMLCA</i> .....	266
<b>16.</b>	<b>ACRONYMS</b> .....	<b>271</b>

---

## List of figures

FIGURE 1	ENERGY FEED STOCK AND THEIR MEAN OF DISTRIBUTION (ADAPTED FROM BESSOU ET AL., 2009) .....	24
FIGURE 2	OVERALL STRUCTURE OF MANUSCRIPT .....	28
FIGURE 3	TYPICAL LCT APPROACH FOR A PRODUCT .....	30
FIGURE 4	LCT APPLICATION AND USERS .....	31
FIGURE 5	SUSTAINABILITY THROUGH LCT .....	32
FIGURE 6	SUSTAINABILITY ASPECTS WITH THE RESPECTIVE INFLUENCE OF ITS THREE CONSTITUENTS.....	35
FIGURE 7	JATROPHA BIODIESEL SUSTAINABILITY ISSUE.....	37
FIGURE 8	GENERAL OVERVIEW OF A PRODUCT LIFE CYCLE .....	40
FIGURE 9	GLOBAL CONCEPT OF LCA FOR BIODIESEL.....	44
FIGURE 10	MAP OF BIOETHANOL WORLDWIDE PRODUCTION .....	52
FIGURE 11	EUROPEAN UNION BIOFUEL PRODUCTION (SOURCE: EUROSTAT).....	53
FIGURE 12	TERMINOLOGY FOR ENERGY WITH THEIR SOURCE OF ORIGIN (ADAPTED FROM WWW.IEA.ORG).....	54
FIGURE 13	OVERVIEW OF BIOFUEL FEEDSTOCK, PROCESSING AND PRODUCTS.....	56
FIGURE 14	A THREE YEARS OLD JATROPHA PLANT (SOURCE: CIRAD).....	64
FIGURE 15	SEEDS OF JATROPHA (SOURCE: CIRAD).....	65
FIGURE 16	JATROPHA. CURCAS L. CULTIVATION: PLANTATION FIELD (SOURCE: WWW.BIOFUELSDIGEST.COM).....	66
FIGURE 17	CULTIVATED SURFACE IN THE WORLD FOR JATROPHA PRODUCTION (SOURCE: JATROPHABOOK.ORG).....	67
FIGURE 18	JATROPHA BIODIESEL PRODUCTION CYCLE.....	69
FIGURE 19	BIODIESEL PRODUCTION SEQUENCE .....	71
FIGURE 20	A PRODUCT LIFE CYCLE FROM CRADLE TO GRAVE.....	86
FIGURE 21	LCA METHODOLOGY FRAMEWORK WITH RESPECT TO ISO 14044 NORMS.....	87
FIGURE 22	GENERAL PHASES FOR IMPACT ASSESSMENT IN LCA (ADAPTED FROM JOLLIET ET AL., 2010).....	92
FIGURE 23	PROCESS TREE FOR JATROPHA BIODIESEL PRODUCTION SYSTEM.....	99
FIGURE 24	JATROPHA PRODUCTION ON LIFE CYCLE APPROACH.....	101
FIGURE 25	REPRESENTATION OF INVENTORY RESULT TOWARD IMPACT ASSESSMENT (ADAPTED FROM JOLLIET ET AL., 2010) . .....	106
FIGURE 26	EXAMPLE FOR SUBSTANCE SELECTION FOR NON-CARCINOGENIC IMPACT IN IMPACT 2002+ .....	107
FIGURE 27	NON-RENEWABLE RESOURCE DEPLETION WITH IMPACT 2002+ (* TOTAL YEARS OF PRODUCTION ARE 30 SO THE SUM CAN BE OBTAINED BY 4TH YR. OF PRODUCTION MULTIPLY BY 27) .....	108
FIGURE 28	GLOBAL WARMING WITH IMPACT 2002+ (* TOTAL YEARS OF PRODUCTION ARE 30 SO THE SUM CAN BE OBTAINED BY 4TH YR OF PRODUCTION MULTIPLY BY 27) .....	109
FIGURE 29	OZONE LAYER DEPLETION OF JATROPHA THROUGH IMPACT 2002+ (* TOTAL YEARS OF PRODUCTION ARE 30 SO THE SUM CAN BE OBTAINED BY 4TH YR OF PRODUCTION MULTIPLY BY 27).....	110

FIGURE 30	RESPIRATORY INORGANICS WITH IMPACT 2002+ (* TOTAL YEARS OF PRODUCTION ARE 30 SO THE SUM CAN BE OBTAINED BY 4TH YR OF PRODUCTION MULTIPLY BY 27) .....	111
FIGURE 31	PHOTO CHEMICAL OXIDATION OF JATROPHA THROUGH IMPACT 2002+ (* TOTAL YEARS OF PRODUCTION ARE 30 SO THE SUM CAN BE OBTAINED BY 4TH YR OF PRODUCTION MULTIPLY BY 27) .....	111
FIGURE 32	ECOTOXICITY IMPACT WITH IMPACT2002+ (* TOTAL YEARS OF PRODUCTION ARE 30 SO THE SUM CAN BE OBTAINED BY 4TH YR. OF PRODUCTION MULTIPLY BY 27) .....	112
FIGURE 33	ACIDIFICATION WITH IMPACT2002+ (* TOTAL YEARS OF PRODUCTION ARE 30 SO THE SUM CAN BE OBTAINED BY 4TH YR. OF PRODUCTION MULTIPLY BY 27) .....	113
FIGURE 34	EUTROPHICATION IMPACT OF JATROPHA THROUGH IMPACT 2002+ (* TOTAL YEARS OF PRODUCTION ARE 30 SO THE SUM CAN BE OBTAINED BY 4TH YR. OF PRODUCTION MULTIPLY BY 27).....	113
FIGURE 35	CARCINOGENS AND NON-CARCINOGENS WITH IMPACT2002+ (* TOTAL YEARS OF PRODUCTION ARE 30 SO THE SUM CAN BE OBTAINED BY 4TH YR. OF PRODUCTION MULTIPLY BY 27) .....	114
FIGURE 36	HUMAN HEALTH CHARACTERIZATION WITH IMPACT 2002+.....	115
FIGURE 37	ECOSYSTEM CHARACTERIZATION WITH IMPACT 2002+.....	115
FIGURE 38	CLIMATIC CHANGE CHARACTERIZATION WITH IMPACT 2002+.....	115
FIGURE 39	NON-RENEWABLE ENERGY CHARACTERIZATION WITH IMPACT 2002+ .....	116
FIGURE 40	EXCEL NORMALIZED IMPACT CHARACTERIZATION THROUGH IMPACT2002+ .....	125
FIGURE 41	SIMAPRO IMPACT CHARACTERIZATION THROUGH IMPACT 2002+ .....	126
FIGURE 42	INTEGRATION OF LIFE CYCLE APPROACHES FOR PROCESS DESIGN AND OPTIMIZATION (JACQUEMIN ET AL., 2012) .. .....	130
FIGURE 43	GLOBAL VISION OF PROPOSED FRAMEWORK FOR STUDY .....	132
FIGURE 44	IDEA OF PSE EMBEDDED LCA.....	145
FIGURE 45	LCA EMBEDDED PSE IDEA (ADAPTED FROM KNIEL ET AL., 1996) .....	147
FIGURE 46	DECISION PROCESS FOR ENVIRONMENTAL EVALUATION .....	149
FIGURE 47	BPMN DIAGRAM GIVING AN OVERVIEW OF INTERACTIONS.....	151
FIGURE 48	CLASS DIAGRAM USED TO REPRESENT INFORMATION MODEL .....	152
FIGURE 49	TASKS FOR TRANSESTERIFICATION SIMULATION AND COUPLING .....	157
FIGURE 50	DIAGRAM FOR MODELING A BATCH PROCESS OF TRANSESTERIFICATION (BALLERINI, 2006) .....	159
FIGURE 51	TRANSESTERIFICATION REACTION .....	159
FIGURE 52	SAPONIFICATION REACTION.....	160
FIGURE 53	SCREEN SHOT OF USER INTERFACE OF THE SIMULATOR IN MICROSOFT EXCEL .....	162
FIGURE 54	PROCESS FLOWSHEET FOR EXCEL SIMULATOR OF TRANSESTERIFICATION .....	163
FIGURE 55	PROSIM PLUS FLOWSHEET MODELING FOR ESTERFIP .....	168
FIGURE 56	STRUCTURE OF TRIOLEIN .....	170
FIGURE 57	APPROACH FOR SIMLCA STRUCTURE .....	177
FIGURE 58	OVERVIEW OF PRESENT FRAMEWORK .....	178

FIGURE 59	EXAMPLE OF OBJECTS FOR PROPOSED FRAMEWORK .....	181
FIGURE 60	SIMLCA MAIN USER INTERFACE .....	183
FIGURE 61	SCREEN SHOT OF AN ESTABLISHED SIMLCA.....	184
FIGURE 62	COMPARISON BETWEEN RESULTS FROM SIMLCA AND SIMAPRO WITH CML 2 BASELINE 2000 .....	185
FIGURE 63	COMPARISON BETWEEN RESULTS FROM SIMLCA AND SIMAPRO WITH IMPACT 2002.....	186
FIGURE 64	COMPARISON BETWEEN MIDPOINT IMPACTS BEFORE AND AFTER COUPLING LCA/PSE (USED METHOD: IMPACT 2002+).....	192
FIGURE 65	COMPARISON OF MIDPOINT IMPACT (IMPACT 2002+) WITH RESPECTIVE DEPENDENCE ON FU.....	195
FIGURE 66	PRODUCTION OF FIRST GENERATION BIOETHANOL.....	224
FIGURE 67	ANAEROBIC DIGESTION/METHANISATION PROCESS IN DETAIL.....	225
FIGURE 68	PRODUCTION OF BIOETHANOL THROUGH BIOCHEMICAL METHOD .....	227
FIGURE 69	PRODUCTION OF BIODIESEL THROUGH THERMOCHEMICAL PROCESS.....	229
FIGURE 70	RACEWAY TYPE CULTURING OF MICRO ALGAE FOR BIOFUEL PRODUCTION (SOURCE: WWW.GENI.ORG).....	230
FIGURE 71	IMPACT ASSESSMENT THROUGH EXCEL WITH CML 2 BASELINE .....	231
FIGURE 72	IMPACT ASSESSMENT THROUGH SIMAPRO WITH CML 2 BASELINE .....	231
FIGURE 73	PROCESS FLOW CHART OF BIODIESEL PRODUCTION.....	236
FIGURE 74	THE FOUR-STEP BASE CATALYZED TRANSESTERIFICATION OF TRIACYLGLYCEROL.....	239
FIGURE 75	HOMOGENEOUS BATCH PROCESS ESTERFIP PROCESS – IFP LICENCE (BALLERINI, 2006) .....	243
FIGURE 76	SCHEMATIC DESIGN OF A CONTINUOUS PROCESS OF EMHV (PROCESS PROPOSED BY THE LURGI COMPANY) (BALLERINI, 2006) .....	244
FIGURE 77	SCHEMATIC DESIGN OF A HETEROGENEOUSLY CATALYZED CONTINUOUS PROCESS OF EMHV (IFP PROCESS) (BALLERINI, 2006) .....	245
FIGURE 78	BIOX COSOVENT PROCESS (DEMIRBAS, 2008).....	246
FIGURE 79	SUPERCRITICAL TRANSESTERIFICATION PROCESS (DEMIRBAS, 2008) .....	247
FIGURE 80	BLACK BOX OF THE PROCESS FOR THE REACTION OF TRANSESTERIFICATION .....	249
FIGURE 81	CLASSIC REACTION OF TRANSESTERIFICATION.....	250
FIGURE 82	BALANCES WITH A CONVERSION RATIO EQUALS TO 97% .....	253
FIGURE 83	CHEMICAL STRUCTURE OF THE TRIOLEIN .....	254
FIGURE 84	TRIGLYCERIDE CONCENTRATION VERSUS TIME FOR THE KINETIC MODEL .....	259
FIGURE 85	CONVERSION RATE FOR TRIGLYCERIDE OVER TIME PERIOD OF KINETIC MODEL 1 .....	260
FIGURE 86	TRIGLYCERIDE CONCENTRATION VERSUS TIME FOR THE KINETIC MODEL-2 .....	261
FIGURE 87	CONVERSION RATE FOR TRIGLYCERIDE OVER TIME PERIOD OF KINETIC MODEL-2.....	261



---

## List of tables

---

TABLE 1	INDUSTRIAL RESPONSE TO ENVIRONMENTAL CONCERNS (ADAPTED FROM: JACQUEMIN ET AL., 2012) .....	26
TABLE 2	LIST OF METHODOLOGIES USED FOR LIFE CYCLE THINKING (INSPIRED FROM: JOLLIET ET AL.,2010).....	32
TABLE 3	LIST OF LCT METHODS FOR ENVIRONMENTAL EVALUATION .....	33
TABLE 4	SOME SUSTAINABILITY ISSUES IN THE LIFE CYCLE OF BIOFUELS (ADAPTED FROM AZAPAGIC AND STICHNOTHE, 2010). .....	37
TABLE 5	METHOD FOR CONVERSION OF VEGETABLE OIL TO BIODIESEL.....	70
TABLE 6	SWOT ANALYSIS FOR JATROPHA (ADAPTED FROM RUTZ AND JANSSEN, 2007).....	74
TABLE 7	INPUT DATA USED FOR JATROPHA LCA .....	104
TABLE 8	REPORTED VALUES FOR DATA QUALITY FROM DIFFERENT PROCESSES (NDONG ET AL., 2009 MAKKAR AND BECKER 2009) .....	104
TABLE 9	SELECTION OF THE SUBSTANCES FOR EACH CATEGORY IN IMPACT 2002+.....	106
TABLE 10	QUALITY INDICATOR AND DATA UNCERTAINTY ANALYSIS (WEIDEMA AND WESNAES, 1996).....	119
TABLE 11	UNCERTAINTY ANALYSIS FOR JATROPHA LCI .....	120
TABLE 12	COMPARISONS BETWEEN JATROPHA BASED LCA STUDIES .....	122
TABLE 13	COMPARISON OF FOSSIL FUELS WITH BIOFUELS (SOURCE: ADEME 2013) .....	124
TABLE 14	COMPONENTS WITH THEIR CHEMICAL FORMULAS, REFERENCE AND RESPECTIVE PROCESSES.....	160
TABLE 15	TABLE OF EQUIVALENCE BETWEEN THE VARIABLES IN THE CONTINUOUS PROCESS PROSIM PLUS AND MAGNITUDES OF DISCONTINUOUS ESTERFIP PROCESS .....	167
TABLE 16	ORIGIN OF DIFFERENT CONSTITUENTS USED FOR PROSIM PLUS SIMULATOR .....	170
TABLE 17	PROPERTIES OF THE CONSTITUENT PRESENT IN PROSIM PLUS .....	171
TABLE 18	UNITARY OPERATIONS USED IN PROSIM PLUS FOR ESTERFIP PROCESS MODELING .....	171
TABLE 19	OPERATING CONDITION PRESENT AT REACTOR .....	171
TABLE 20	OPERATING CONDITION PRESENT AT DISTILLATION COLUMN .....	172
TABLE 21	TABLE OF RELATIVE DIFFERENCES MAGNITUDES CALCULATED BETWEEN EXCEL SIMULATOR AND PROSIM PLUS..	174
TABLE 22	DIFFERENT SCENARIOS FOR RESULT EVALUATION .....	190
TABLE 23	CURRENT EVALUATION OF FIRST GENERATION BIOFUEL REPLACING FOSSIL FUEL (SOURCE: (ADEME, 2013)....	226
TABLE 24	STUDIES RELATED TO ALKALINE CATALYZED TRANSESTERIFICATION OF JATROPHA.....	234
TABLE 25	EXPERIMENTAL CONDITIONS FOR THE REACTION.....	241
TABLE 26	EFFECT OF THE KIND OF ALCOHOL ON THE REACTION RATE .....	242
TABLE 27	PRODUCT PROPERTIES (DEMIRBAS, 2007).....	249
TABLE 28	DESCRIPTION OF THE INPUT AND OUTPUT STREAMS.....	250
TABLE 29	COMPOSITION AND PROPERTIES OF JATROPHA OIL (LIU ET AL., 2011) .....	251
TABLE 30	COMPOSITION IN TRIGLYCERIDE IN JATROPHA OIL (LIU ET AL., 2011) .....	252

---

TABLE 31	COMPOSITION OF TRIGLYCERIDE IN JATROPHA OIL FROM INDONESIA .....	252
TABLE 32	MOLAR MASS OF THE INPUTS AND OUTPUTS OF THE REACTION .....	253
TABLE 33	UNIFAC DORTMUND DECOMPOSITION FOR THE TRIOLEIN.....	255
TABLE 34	OPERATING CONDITION FOR KINETIC MODEL-1.....	258
TABLE 35	PARAMETERS OF KINETIC MODEL-1 .....	259
TABLE 36	OPERATING CONDITION FOR KINETIC MODEL-2 .....	260
TABLE 37	PARAMETERS FOR KINETIC MODEL-2 .....	260
TABLE 38	OPERATING CONDITIONS FOR ESTERFIP PROCESS UNDER STUDY.....	262
TABLE 39	TABLE WITH GIVEN FLUX .....	263
TABLE 40	MIDPOINT IMPACTS (IMPACT 2002+) FOR THE PRODUCTION OF 1MJ BIODIESEL (METHYLESTER) IN FUNCTION TO CONVERSION RATE CRUDE JATROPHA OIL IN METHYLESTER (BEFORE COUPLING OF PROCESS SIMULATOR AND LCA) .....	266
TABLE 41	MIDPOINT IMPACTS (IMPACT 2002+) FOR THE PRODUCTION OF 1MJ BIODIESEL (METHYLESTER) IN FUNCTION TO CONVERSION RATE CRUDE JATROPHA OIL IN METHYLESTER (WITHOUT ASSOCIATED AVOIDED IMPACT OF GLYCERIN) (AFTER COUPLING OF PROCESS SIMULATOR AND LCA) .....	266
TABLE 42	MIDPOINT IMPACTS (IMPACT 2002+) FOR THE PRODUCTION OF 1MJ BIODIESEL (METHYLESTER ONLY) IN FUNCTION TO CONVERSION RATE CRUDE JATROPHA OIL IN METHYLESTER (WITHOUT ASSOCIATED AVOIDED IMPACT OF GLYCERIN) (AFTER COUPLING OF PROCESS SIMULATOR AND LCA) .....	267
TABLE 43	MIDPOINT IMPACTS (IMPACT 2002+) FOR THE PRODUCTION OF 1MJ BIODIESEL (METHYLESTER + CRUDE JATROPHA OIL) IN FUNCTION TO CONVERSION RATE CRUDE JATROPHA OIL IN METHYLESTER (WITH THE ASSOCIATED AVOIDED IMPACT OF GLYCERIN) (AFTER COUPLING OF PROCESS SIMULATOR AND LCA).....	267
TABLE 44	MIDPOINT IMPACTS (IMPACT 2002+) FOR THE PRODUCTION OF 1MJ BIODIESEL (METHYLESTER ONLY) IN FUNCTION TO CONVERSION RATE CRUDE JATROPHA OIL IN METHYLESTER (WITH THE ASSOCIATED AVOIDED IMPACT OF GLYCERIN) (AFTER COUPLING OF PROCESS SIMULATOR AND LCA) .....	268
TABLE 45	RELATIVE DIFFERENCE BETWEEN THE RESULTS OF IMPACTS BEFORE AND AFTER COUPLING .....	268
TABLE 46	RELATIVE DIFFERENCE BETWEEN THE RESULTS OF IMPACTS WITH OR WITHOUT TAKING INTO ACCOUNT THE ASSOCIATED IMPACTS OF GLYCERIN .....	269

---

## List of equations

---

EQUATION 1	INVENTORY FOR EACH UNIT PER FU .....	89
EQUATION 2	TOTAL INVENTORY .....	89
EQUATION 3	MIDPOINT CALCULATION FOR IMPACT SCORE (SI) .....	91
EQUATION 4	CALCULATION OF DAMAGE ASSESSMENT (SD) .....	91
EQUATION 5	CALCULATION OF STANDARD DEVIATION IN UNCERTAINTY ANALYSIS .....	117
EQUATION 6	ALCOHOLYSIS .....	237
EQUATION 7	ACIDOLYSIS OF AN ESTER.....	237
EQUATION 8	ESTER-ESTER EXCHANGE .....	237
EQUATION 9	BIODIESEL PRODUCTION.....	238
EQUATION 10	NEUTRALIZATION REACTION .....	257
EQUATION 11	REACTION FOR THE FORMATION OF FATTY ACIDS.....	257
EQUATION 12	.....	259



---

# PART A

---

## **A. SCIENTIFIC CONTEXT AND STATE OF THE ART**



---

The first part belongs to presentation of the research topics and its organization. Hypothesis drawn for this research work and objectives highlights are inspected in accordance with the research topic. Further sustainability related to biofuel and its evaluation linked with the methodology of life cycle assessment is introduced. This section also gives an insight to process system engineering, its role in the sustainability of biofuels. Section starts by describing the growing importance of life cycle assessment and process system engineering and the need for their integration with respect to product-process-system point of view. Further the different sources and generations of bioenergy and biofuels with a brief historical background and the global situation related to them are classified. Jatropha biodiesel production system is used as a case study. We provide an overview of Jatropha curcas and biodiesel production, critics related to Jatropha, its economic viability for commercial production and environmental issues related to Jatropha. Finally the last chapter of this part is dedicated to the proposal for defined objectives and the field of present research.

This part is subjected to (Gillani et al., 2010).





---

## 1. Introduction

---

In this chapter the context and organization of present work are described. Then a brief presentation of the items included in this manuscript about the way they are inter-connecting is provided. At the end the main objectives drawn for present research are presented.

## 1.1 RESEARCH CONTEXT

Biomass is the oldest and the most widely exploited renewable energy source. It can be grown in most areas and the diversity of plants makes it possible to provide biomass the whole year round. However, contrarily to flow resources such as solar or wind energy, biomass stock are constrained by feedstock productivity and land exploitation rates, and by a maximum environmental load. The latter corresponds to the maximum production that can be achieved within a given agro ecosystem without breaking the balance between the resources that can be supplied and the amounts of pollutants that can be digested by the ecosystem. Agricultural biomass production systems are particularly constrained. On the one hand, agriculture must satisfy to an exponentially increasing demand through population growth (including changes toward more caloric diets), and the diversification of biomass uses. On the other hand, the intensification of production systems to match this demand leads to critically-high environmental loads. Figure 1 shows different types of energy feedstock with their respective methods of conversion from biomass and their mean of distribution for the end uses.

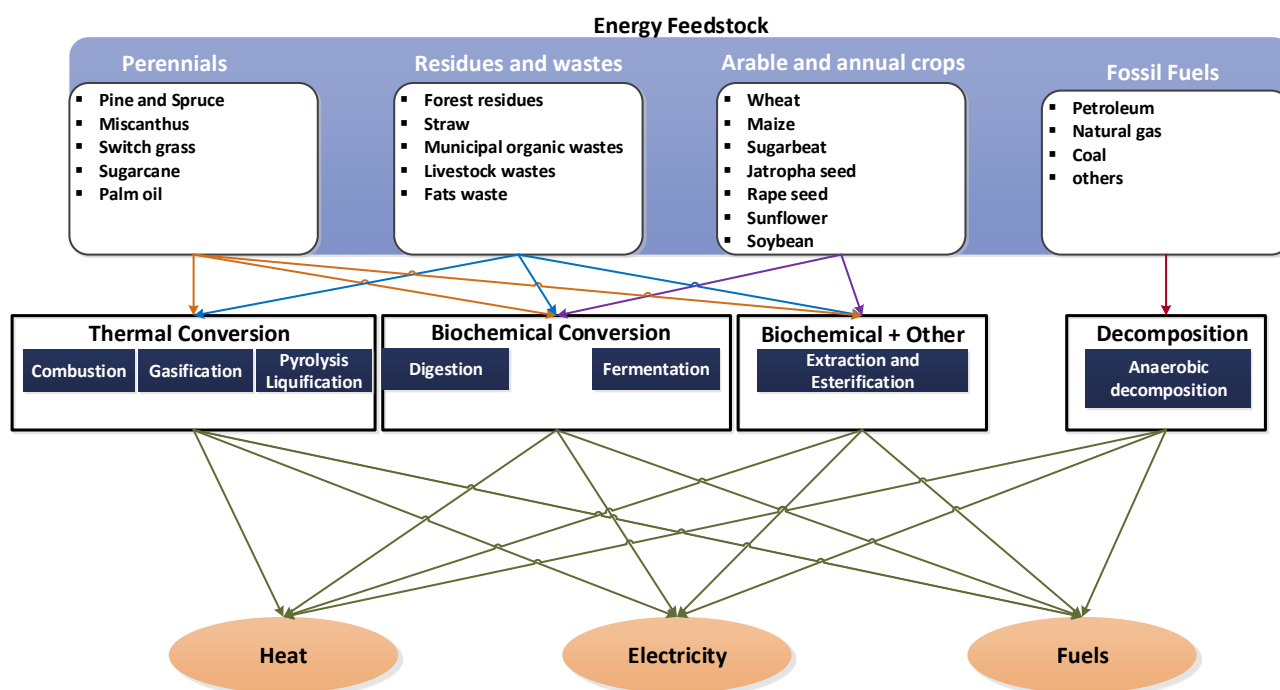

Figure 1 Energy feed stock and their mean of distribution (Adapted from Bessou et al., 2009)

Biofuels are fuels produced from renewable source of biomass, more often in liquid form. Renewable stock resources, mainly biomass, are limited resources and their availability depends both on other primary natural resources (e.g. lands, water, ecosystems, etc.) and on natural regeneration/degeneration rates and/or anthropic production/consumption rate. (Bessou et al., 2009). Among renewables, they have been particularly fostered for their possible

contribution in reducing greenhouse gas emissions by the transport sector, which is the major growing contributor to the greenhouse gas emissions. In this view, the interest of liquid biofuel relies on their ability to be blended and distributed with fossil fuels, and on the possibility to save diffuse greenhouse gas emissions from transport, whereas stationary emissions at site may be captured by other advanced technologies. However, biofuels are still source of pollutions that are linked to the production of the agricultural biomass and to its conversion and distribution. The overall interest of biofuels hence depends on the global savings they may enable compared to the fossil fuels they would substitute. Many studies have been published that compare the environmental impacts of fossil fuel chains and biofuel chains. However, their results are highly variable, which has contributed to create some confusion on the overall interest of biofuels.

The need to quantify the environmental impacts of anthropogenic activities has never been more urging, as we started to observe their cumulative effects (e.g. the depletion of the ozone layer, global warming etc.). While actions should be taken immediately to try and mitigate these effects, our quantitative knowledge on the potential impacts of alternative production systems (in particular to substitute fossil resources) is still incomplete. Predicting the environmental impacts of such systems requires a capacity to model future scenarios by reproducing the underlying mechanisms leading to environmental pollution. Despite their common life-cycle based approach, not all these studies are complete Life cycle assessments, i.e. assessments that encompass all the potential environmental impacts throughout the product chain. LCA is a holistic and standardized method that makes comparisons complete and less subjective.

Nevertheless, LCAs of biofuel are especially complex to establish and to interpret because of:

- The complexity of the environmental impact mechanisms of agricultural productions,
- The difficulty to deal with the diversity of co-products generated during the biomass conversion.

Resulting from these constraints, assessments are often lacking in transparency concerning the data quality and the underlying assumptions in co-product handling, which adds to the complexity to conclude on the impacts of a biofuel chain. Good data quality standards are paramount to the reliability of LCAs, and are well defined in Guinée, (2002). They include criteria such as transparency, completeness, and relevance. It is however problematic to gather the wealth of data required by the LCA that meet all these criteria. In particular, the data from the agricultural step are subject to high uncertainty, due to both

- The variability related to local climatic, edaphic and management factors (often disregarded)

- Limited understanding and modeling of the underlying mechanisms. Agricultural causes a diverse range of environmental impacts.

They are linked to management practices and in particular to the use of inputs such as fertilizers or pesticides. The type and state of the ecosystem, i.e. the soil, climate, fauna and flora, and pollution background levels, also influence the way a given input contributes to the diverse impact mechanisms. All these issues then lead us to the question of sustainability or sustainable options. The idea and issues related to sustainability is further discussed in chapter 2. Derived from bio based materials, biodiesel are chosen as potential contributor for reducing GHG emissions as well as providing a security of energy supply to transport sector. Therefore sustainability of biofuels should be assessed intensively, considering all the relevant environmental, economic and social aspects. To avoid a shift of impacts along the supply chain, sustainability should be assessed by taking in account the overall life cycle of biofuels, including feedstock cultivation and biodiesel production process.



Approach	Till 1980s	1980-90	1990-2000	2000-onwards
	Compliant	Proactive	Progressive	Dynamic
Environmental	Limited to certain fields and departments	Environmental awareness for all sector and fields	Well established environmental concerns in all sector	Environmental certification in all sectors
Legislative	Control on emission and wastes	Integration of pollutant control with legislations	Advanced environmental policy in product integration	Policy orientation for greener products
Management	Inspection	Environmental standard and audits	Eco-designing and efficiency for industrial ecology	ISO certification, Eco-labeling, eco-designing, green washing and optimization
Wastes control	End of pipe protection	LCA approach for process innovation	LCA development and LCA tool integration for industrial processes	More advanced and product process oriented LCA tools development for industrial evaluation

Table 1 Industrial response to environmental concerns (Adapted from: Jacquemin et al., 2012)

In the twentieth century, the industrial sector became aware of the negative impacts generated by human activities. This helps to raise the voice to react and develop the new behaviors in order to avoid these negative impacts for further environmental damage. The first industries to come under scrutiny were the chemical processes and heavy industry sector; however this has tended to evolve to cover other sectors and different sizes of industry (Jacquemin et al., 2012). Table 1 shows the response of industry to increased environmental pressure in a progressive way. We add the “Dynamic” vision of industrial response proposed through the present study for 21<sup>st</sup> century onwards. At present scientific area of Process System Engineering (PSE) has long been recognized as a promising method to design and operate an efficient and sustainable chemical process. PSE provides handful solution to manage engineering systems by enabling the use of modeling, simulation, optimization, planning and control for given system. In our research we provide the aspects of PSE for LCA in order to

have a more sustainable product and process based environmental analysis through a model development, process designing, and simulation and with some hints from optimization.

PSE is a relatively young field of chemical engineering which “develops methods and tools that allow industry to meet its needs by tying science to engineering” (Grossmann, 2004) and encompasses a vast range of industries, such as petrochemical, mineral processing, advanced material, food, pharmaceutical and biotechnological. PSE has played an important role over the last decade by developing many useful concepts, tools and techniques for improving the viability of chemical processes, making them more and more industrially feasible (Grossmann, 2003), e.g. the use of statistical signal processing techniques in process operation, or the optimization and use of artificial intelligence methods in process design. In 2000, Grossman and Westerberg broadened the definition of PSE to “the improvement of decision-making processes for the creation and operation of the chemical supply chain (Grossmann and Westerberg, 2000). Applying life cycle thinking this research work follows process system engineering methods and tools for process eco-design for a biodiesel production system from *Jatropha* as a case study. This case study helps to identify relevant sustainability criteria and how to use the obtained information to make decision in response to the needs and requirements of sustainable growth.

## 1.2 DISSERTATION STRUCTURE, PLAN AND PROPOSED TASKS

This Ph.D. is part of the research activities of LGC (Laboratoire de Génie Chimique) CNRS UMR 5503 and LCA (Laboratoire de Chimie Agro Industrielle), INRA UMR 1010, Université de Toulouse.

The present manuscript is built on four Parts. So first we start with presentation and findings of a literature review that focuses on LCA concepts, methods and tools, especially dedicated to agriculture and process engineering literature. The second section deals with definition and concepts of biofuels and LCA in general.

These blocks are assigned to four main parts, following a general introduction and leading to overall conclusions and perspectives (Figure 2):

Part A: First part is related to our project overview, the objectives and hypothesis. Also we presented our research model and guidelines in this part. Literature review on biofuels and its sustainability with a special focus on *Jatropha* biodiesel production from *Jatropha* are highlighted in this part. This review also explores some broader aspects of sustainability, bioenergy, i.e. economic and political frameworks and biomass potential. We also provide a short overview of process system engineering in this part.

Part B: This part includes the methodology of LCA with a case study on *Jatropha* biodiesel production system. The limits identified during LCA and their proposed solutions are also a part of this section.

Part C: This part starts with the review and proposal of coupling between PSE and LCA followed by the simulation of important unitary process. Then the coupling is presented in this part followed by the results validation. Results of the modeling work on the impacts of emissions in the Jatropha biodiesel production and our application framework are discussed.

Part D: We present our conclusion from this research work and its perspective for future evaluation is illustrated in detail. Then we provide the bibliography and the appendix in the last section of this part to put “The End” for this manuscript.

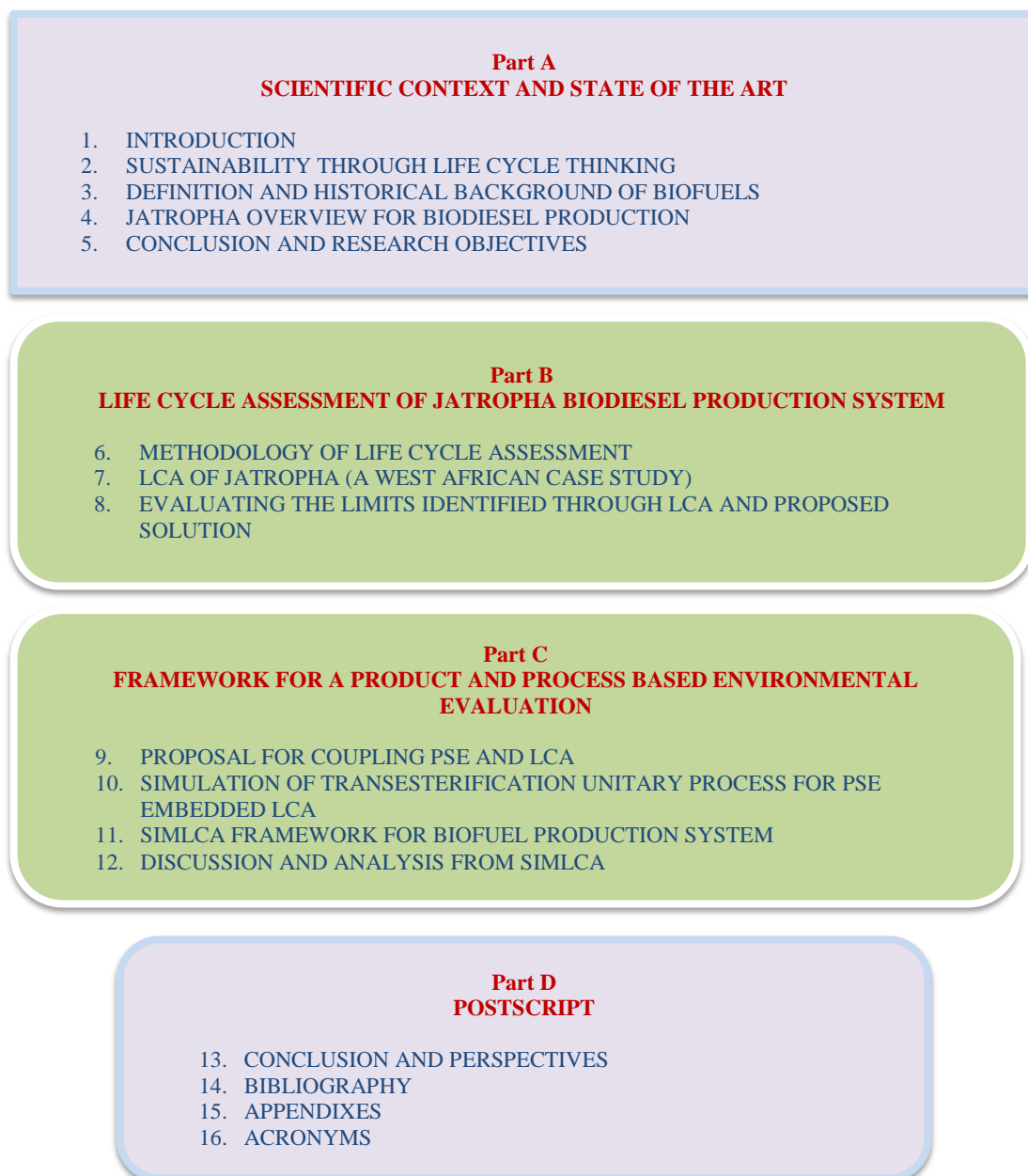

Figure 2 Overall structure of manuscript

---

## 2. Sustainability through Life Cycle Thinking

---

As environmental awareness increases, industries and businesses are assessing how their activities affect the environment. Society has become concerned about the issues of natural resource depletion and environmental degradation. Many businesses have responded to this awareness by providing “greener” products and using “greener” processes. The environmental performance of products and processes has become a key issue, which is why some companies are investigating ways to minimize their effects on the environment. Many companies have found it advantageous to explore ways of moving beyond compliance using pollution prevention strategies and environmental management systems to improve their environmental performance. This chapter introduces the core idea of sustainability and gives an overview of Life Cycle Thinking (LCT) with its background and uses sector of society and industries. Several examples are also presented in order to know how different environmental product and activities can be identified through life cycle thinking.

## 2.1 LIFE CYCLE THINKING FOR SUSTAINABILITY

### 2.1.1 Life Cycle Thinking and Sustainability

Life Cycle Thinking (LCT) is a state of mind in which we seek to identify possible improvements to goods and services in the form of lower environmental footprints and reduced use of resources across all life cycle stages. This begins with raw material extraction and conversion, then manufacture and distribution, through to use and consumption. It ends with re-use, recycling of materials, energy recovery and ultimate disposal. All impacts are taken into account, irrespective of where they occur. Building sustainable development requires profound changes in thinking, in economic and social structures for consumption and production patterns. This means the necessary implication of scientific, technological and industrial field, and the creation of methodologies to evaluate sustainability in each specific case. Life Cycle Thinking can help improving environmental performance, social and economic benefits of goods and services considering its full life cycle, avoiding burden shifting. This means minimizing the environmental impacts at one stage of a products life cycle while avoiding further impacts elsewhere. Figure 3 below shows the typical approach of LCT for a product which starts from resources, proceeds towards manufacturing, delivery, use and at the end disposal.

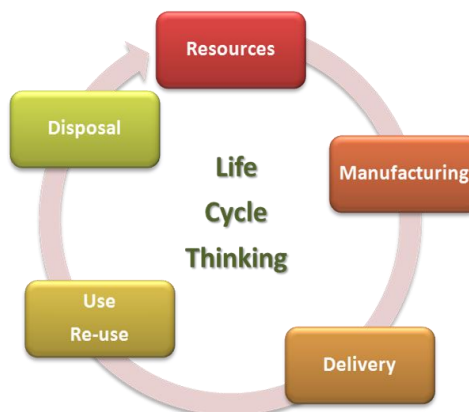

Figure 3 Typical LCT approach for a product

LCT also helps to identify the opportunities that lead to decisions in order to improve environmental performance, image, and economic benefits. Figure 4 provides a picture for LCT, its application and stakeholders/users. Businesses do not always consider their supply chains or the 'use' and 'end-of-life' processes associated with their products. Government actions are often focusing on a specific area, and not on the impacts or benefits that can occur in other areas that are attributable to their own levels of consumption. In this case, without consideration of the full life cycle of goods and services (i.e. supply, use/users and end-of-life), the only



element that suffer is the environment which result in poorer financial performance and higher potential for damage in different levels.

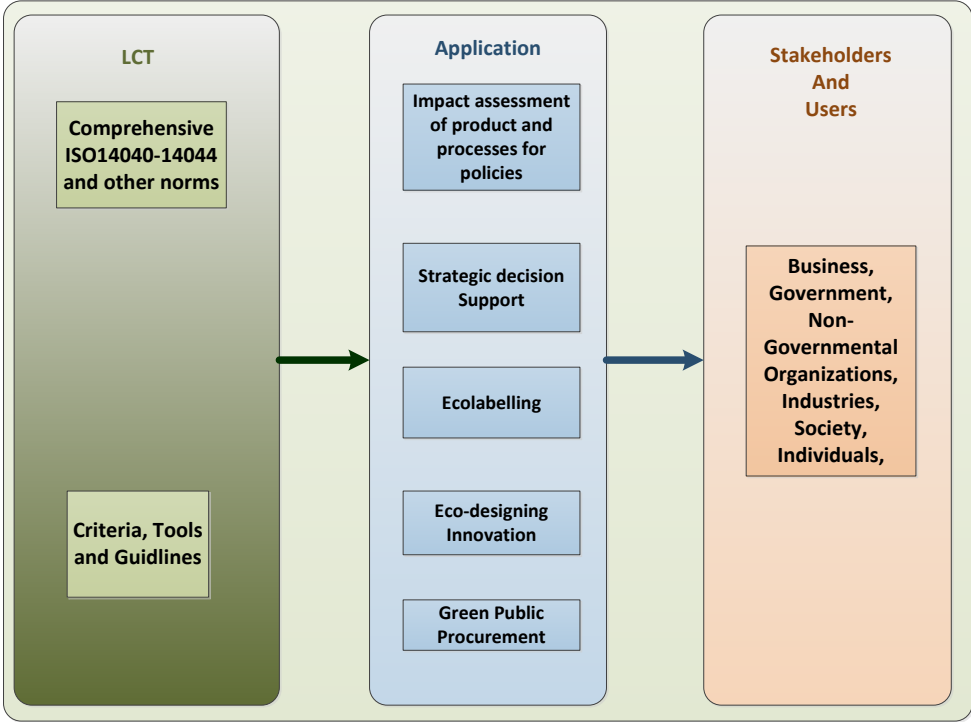

Figure 4 LCT application and users

The things that are design, create and consume contribute substantially to environmental impacts. Sustainability<sup>1</sup> is a paradigm for thinking about the future in which environmental, societal and economic considerations are equitable in the pursuit of an improved lifestyle. Most of the economies are developing with breakneck velocities and becoming epicenters of unsustainable global growth. Immense utilization of natural resources, waste generation and ecological irresponsibility are the reasons for such a dire situation. With the world in majority debating over issues like climate change, water resources, food security, energy efficiency for the last few decades, it is evident that sustainability and green thinking has taken root in all approaches and dialogues. Governments are rethinking their developmental paths adapted to ensure a sustainable lifestyle. Industry, academic institutions, public sectors are taking serious advancement to implement the same. Figure 5 gives a brief highlight of sustainability with taking into consideration its three pillars i.e. Economic, Social and Environment.

<sup>1</sup> According to the definition provided by United Nation World Commission on environment in 1987; Sustainability is, “development that meets the needs of the present without compromising the ability of future generations to meet their own needs”.

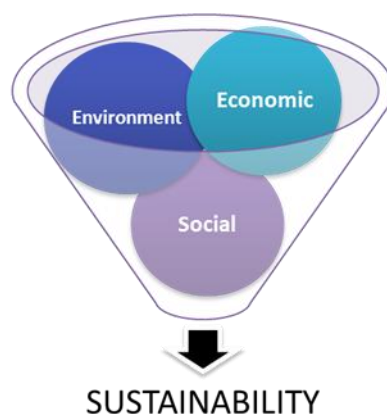

Figure 5 Sustainability through LCT

According to UNEP lifecycle initiative LCT is a way of thinking that includes the economic, environment and social consequences of a product or process over its entire life cycle (Guinée, 2002). Then there are several methodologies to evaluate and measure these impacts. Some of them are listed in Table 2. Among these, LCA is very useful to evaluate and compare the environmental impacts of different systems, taking into account all stages of product life, from extraction of raw materials to final disposition as a product. LCA basically consists of a set of techniques articulated in a systematic objective procedure to identify, classify, and quantify the pollutant loads and the environmental and material resources and energy associated with a product, process or activity from conception to disposal. All these stages are called the product life cycle or more graphically, “from the cradle to the grave”. LCA with the help of ISO 14044 serves as a powerful tool to identify the hotspots in a given product life cycle.

Table 2 List of methodologies used for life cycle thinking (Inspired from: Jolliet et al.,2010)

Life Cycle Thinking									
Methods	Environmental						Social	Economic	
	Life Cycle Assessment (LCA)	Exergy analysis	Material flow analysis (MFA)	Environmental impact assessment (EIA)	Environmental risk assessment (ERA)	Material intensity per unit service (MILP)	Social analysis of life cycle	Cost benefit analysis	Economic input-output analysis

Table 2 provides a list of life cycle thinking methodologies. As this study is related to the environmental part of life cycle thinking, hence we demonstrate the details related to environmental methodology of LCT. These are listed in Table 3.

Table 3 List of LCT methods for environmental evaluation

Method	Description and key points	Advantages	Disadvantages
<b>Environmental Impact Assessment (EIA)</b> (Burgess and Brennan, 2001; Manuilova et al., 2009)	Analyses and evaluates the impacts that human activities can have on the environment. Their main objectives are to consider all possible environmental and socio-economic issues associated with the proposed project in a qualitative and quantitative way and to provide decision makers with the resulting information. This approach use environmental indices. EIA has three major phases: screening and scoping of the project, environmental impact assessment, and decision-making and review.	<ul style="list-style-type: none"> <li>- Environmental damage of the project can then be minimized and any environmental benefits identified.</li> <li>- EIA is a systematic process.</li> </ul>	<ul style="list-style-type: none"> <li>- A specific site and time must be defined to estimate environmental impacts.</li> <li>- Only direct impacts that fall within the boundaries of the system under study are analyzed.</li> <li>- Rigorous and quantitative analysis of the data is often required to make sense of the large amounts of uncollected data.</li> <li>- It is more a legal procedure than a detailed environmental assessment tool.</li> </ul>
<b>Environmental Risk Assessment (ERA)</b> (Ayres and Ayres, 2002; Burgess and Brennan, 2001; Calow, 2009)	Involves the estimation and evaluation of risk to the environment caused by the relationship between level of application of a contaminant or activity and the occurrence of an undesired effect or event. The impact may be on humans, flora or fauna, but also in buildings, land, water or air. Comprise the following steps: problem formulation, hazard characterization, exposure characterization, risk assessment.	<ul style="list-style-type: none"> <li>- Environmental protection legislations are driven by this method.</li> <li>- Facilitates decision making because of the identification of undesired effects.</li> <li>- Takes into account the context of the system under study.</li> </ul>	<ul style="list-style-type: none"> <li>- Time is not explicitly included.</li> <li>- The amount of the environmental impacts generated by a process or service is not calculated.</li> <li>- Difference between risk and hazardous situation must be clear.</li> <li>- Difficulty establishing a scale for measuring risk.</li> </ul>
<b>Exergy analysis</b> (Brunner and Rechberger, 2004; Szargut, 2005)	Measure the maximum amount of work that can be obtained by bringing a resource into equilibrium with its surroundings through a reversible process	<ul style="list-style-type: none"> <li>- Provide information to identify the location, resources and causes of problems form deviations of the ideal system in balance.</li> </ul>	<ul style="list-style-type: none"> <li>- Only focuses a thermodynamic viewpoint.</li> <li>- Complexity in defining the reference state (ideal system in balance).</li> </ul>
<b>Life Cycle Assessment (LCA)</b> (Finnveden et al., 2009; Guinée, 2002; Pennington et al., 2004)	Identify and quantify the process flows and systems which are major contributors to environmental degradation. The scope of the assessment encompasses extraction and processing of raw materials, manufacturing and assembly processes, product distribution, use, re-use, maintenance, recycling and final disposal Regulated and guided by the ISO norm. Four main steps are comprised: goal and scope definition, inventory analysis, impact assessment, and interpretation.	<ul style="list-style-type: none"> <li>- Consider a range of environmental impact categories.</li> <li>- Total economic and environmental burdens of a process can be quantified by performing an LCA in conjunction with a techno-economic feasibility study.</li> <li>- A non-site-specific approach to environmental impacts is required</li> <li>- Long term strategic planning</li> <li>- Identify the areas for improvement which will have the greatest influence on total life cycle impacts</li> </ul>	<ul style="list-style-type: none"> <li>- Lack of data can restrict the conclusions that can be drawn from a specific study.</li> <li>- The intrinsic risks of the processes are not addressed.</li> <li>- LCI data must be used cautiously since production processes differ from country from country.</li> </ul>
<b>Material Flow Analysis (MFA)</b> (Ayres and Ayres, 2002; Brunner and Rechberger, 2004)	Delivers a complete and consistent set of information about all flows and stocks of a particular material within a system. Is based on two fundamental principles: system approach and mass balance. This permit to create a list of the amounts of the different flows. Usually comprises four steps: goal and systems definition, process chain analysis, accounting and balancing, modeling and evaluation.	<ul style="list-style-type: none"> <li>- The analysis can be applied at industrial, national or worldwide scale.</li> <li>- Allow knowing the history of pollution and consumption of resources in an area or region.</li> <li>- Mass balance allows knowing the stock of material ignored or underestimated.</li> </ul>	<ul style="list-style-type: none"> <li>- Focus on a single material.</li> <li>- To determine the environmental impacts a LCA or exergy analysis is needed.</li> </ul>

<b>Material Intensity Per unit Service (MILP)</b> <b>(Brunner and Rechberger, 2004; Ritthoff et al., 2002)</b>	<p>Measures the total mass flow of material caused by production, consumption and waste disposal of defined service unit (fabrication of a kitchen, washing cycle of a dishwasher...) or product. Only use the input flows (consider input flows equals to output flows).</p> <p>The material input is calculated in five categories: abiotic raw materials, biotic raw materials, water, erosion, and air. All material consumption during manufacture, use and recycling or disposal is calculated back to resource consumption by using simple calculation factors expressed in kg or ton.</p> <p>The aim is to reduce the total amount of the addition of all the material and energy flows expressed in kg or tons.</p>	<ul style="list-style-type: none"> <li>- Allow comparisons of resource consumption of different solutions to produce the same service.</li> <li>- Reveals the magnitude of resource use along the life-cycle and help to focus efforts on the most significant phases to reduce environmental burden of the product.</li> <li>- Measure material and energy in the same unit constitutes an excellent communication tool to identify the main problems.</li> </ul>	<ul style="list-style-type: none"> <li>- Does not take into account ecotoxicity of materials or biodiversity.</li> </ul>
---	--	--	--

### 2.1.2 Sustainability of biofuels through life cycle thinking

Many efforts are directed these days toward developing new products and processes that are likely to have a lesser environmental impact. Examples include products based on nanotechnology such as solar cells and water purification devices, fuels based on biomass, green chemistry and environmentally benign manufacturing systems. Also, many corporations are actively reducing the life cycle environmental impact or footprint of their activities. These efforts are certainly encouraging, but unfortunately, in many, if not in most cases, there is little reason to believe that their success leads to greater sustainability. This is because technology alone cannot lead to sustainability since it involves other aspects, which must be taken into account to prevent unpleasant and unexpected surprises. For example, over the decades, despite increasingly efficient technologies, total consumption of energy has continued to increase. This is due to factors such as the economic rebound effect and rampant consumerism. Thus, accounting for socioeconomic aspects should be a part of sustainable engineering. However, even when socio-economic and other non-technological and non-scientific effects are accounted for, existing efforts need not lead to sustainability if they ignore the role of ecosystems.

Sustainability can be framed by three inseparable dimensions: environmental, economic and social. Higher sustainability in one dimension does not necessarily cause higher sustainability in the other. From an environmental point of view J. curcas cultivation is best restricted to wasteland, but is that economically and socially viable? Low technological setups can improve the energy balance and the global warming potential of the system, but on the other hand can imply socially unacceptable labor conditions. Governments and energy companies are not formulating profound changes in the model of consumption of petroleum fuels, but only technological solutions for (a) extending as much as possible the extraction of petroleum at non-prohibitive costs, (b) minimizing the emission of CO<sub>2</sub>, and (c) substituting for

petroleum with liquid biofuels. Figure 6 below provides an overview of sustainability options with its respective influence pillars.

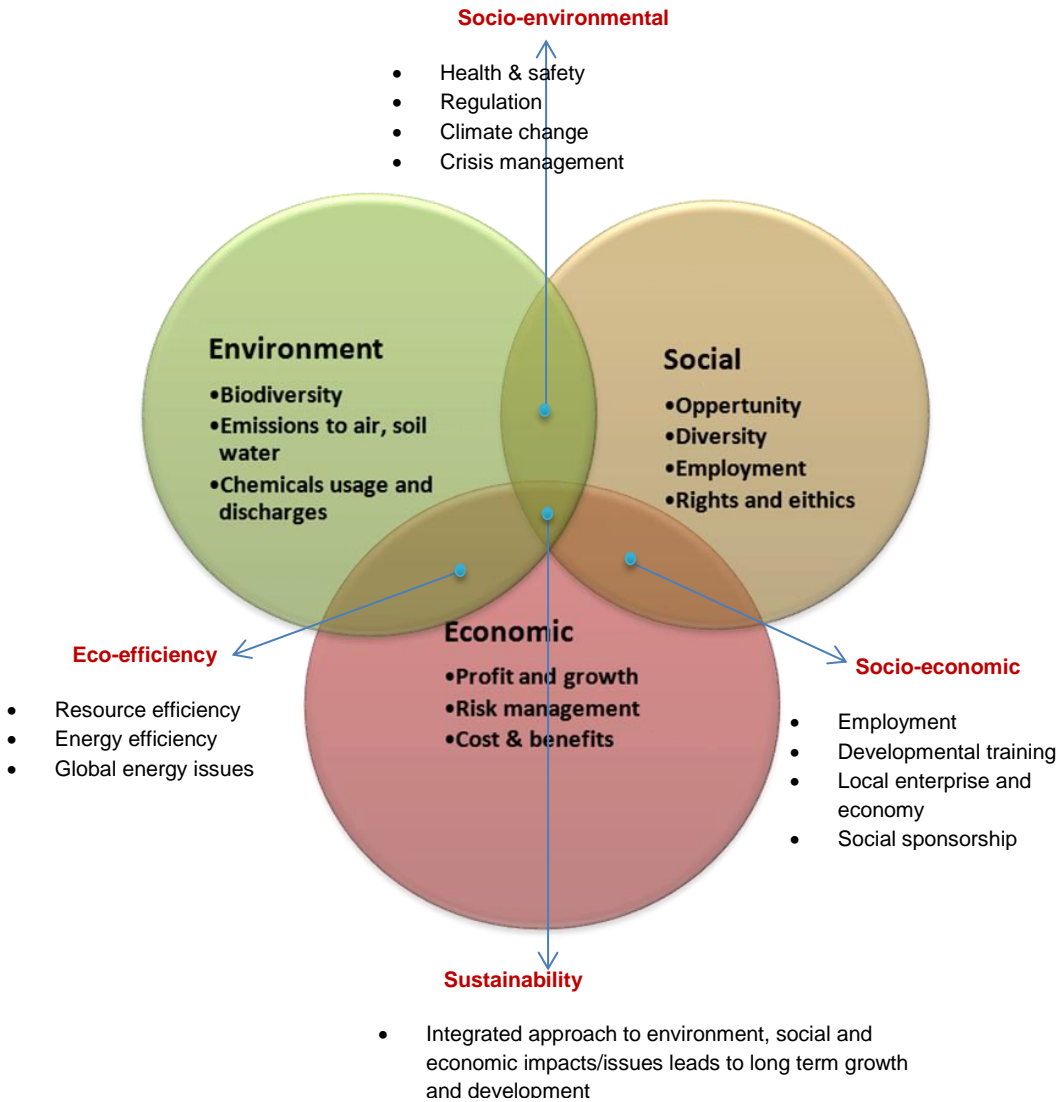

Figure 6 Sustainability aspects with the respective influence of its three constituents

Furthermore, biofuels cannot replace petroleum, in the first place because it cannot be produced, without causing environmental damages greater than those for which it intends to give a solution, on a scale similar to that of petroleum, in accordance with the present and projected demand; in the second place because from biofuels is not possible to extract the multitude of by-products which are produced by the petrochemical industry. One fact which exemplifies the contradiction between a preoccupation with CO<sub>2</sub> emissions into the atmosphere and the plan to continue the model of economic development is that the leading economies, principally the United States, postulate that biofuels, in particular biofuels, permits a reduction in imports of petroleum, while the peripheral economies, especially those located in tropical zones,

plan for the production of biofuels for export to countries like the United States and China, which are the largest emitters of CO<sub>2</sub> into the atmosphere.

To minimize the use of fossil energy and improve the energy balance it is required that the cultivation not include the use of chemical fertilizers, since these represent an elevated level of energy consumption. The data shows that 45% of commercial energy used in global agricultural production is due to the consumption of chemical fertilizers; for that reason, implementing a bioenergy cultivation consuming a huge quantity of energy is, at the least, contradictory. For example, according to the same author, ammonia, the principal source of nitrogenous fertilizers, is produced from natural gas, and the petrochemical industry, which synthesizes it, consumes 1.2% of fossil fuels extracted on the global level. The post-harvest processes for the majority of agro industrial products imply a high consumption of energy derived from the use of indispensable machines; doubtless, in this case one should pay special attention to the energy efficiency of the machines for separating the husk of the seed, the extraction of the oil and the conversion to biodiesel. In this way, the husk can be used for fuel to heating the cauldrons if one opts for extraction of oil by extrusion by heat, or for heating the transesterification reactors for conversion to biodiesel. Regarding this last, it is greatly relevant to mention that although the reaction of transesterification has a high yield level (80%, that is to say that 800 mL of biodiesel are obtained from every liter of vegetable oil) the use of methanol reduces the energy gain.

Methanol, which industrially is obtained from the distillation of petroleum, requires a proportion of 200 mL for each liter of processed oil. Among the alternatives one encounters the use of ethanol, which derives from the fermentation of sugar; although it has the inconvenience that on production it is dissolved in water with a distillation yielding a maximum of 96% alcohol to 4% water. The conversion of vegetable oil to biodiesel is favored by the absence of water, or by minimal quantities thereof. The production of completely anhydrous ethanol raises both costs and energy consumption. Other topic requiring attention is the content of toxic substances of the *J. curcas* seed. Several toxic molecules have been reported in the seed, but the curcin protein and the phorbol esters are the most hazardous for human and animal health. After the oil extraction, the seed cake still contains those substances, representing a potential risk for the *J. curcas* biodiesel workers. The potential of phorbol esters as carcinogens is known. However, a dilemma exists: if non-toxic genotypes are used, problems with pests could be a limitation, as the plant-herbivores interaction would be substantially modified. Alternatives to use the press cake are the physical or enzymatic detoxification for using as fodder, and the composting for using in the same plantation.

### *2.1.2.1 Sustainability of biofuels*

As mentioned earlier that biofuels have emerged as a potentially more sustainable alternative to that of fossil fuels for various reasons (i.e. reduction in GHG, security for supply chain, minimal changes in the existing production technologies, development for rural sector

etc.). Due to these reasons the expectation are high but certain aspects such as additional land requirement, competition with food crops, increase in the food stock, high capital and operating cost render them towards low level of sustainability. That is why one has to be really careful while assessing the sustainability of biofuels keeping in mind all relevant aspects like environmental, economic and social. Figure 7 here provides a benefits and problem criteria along with sustainability.

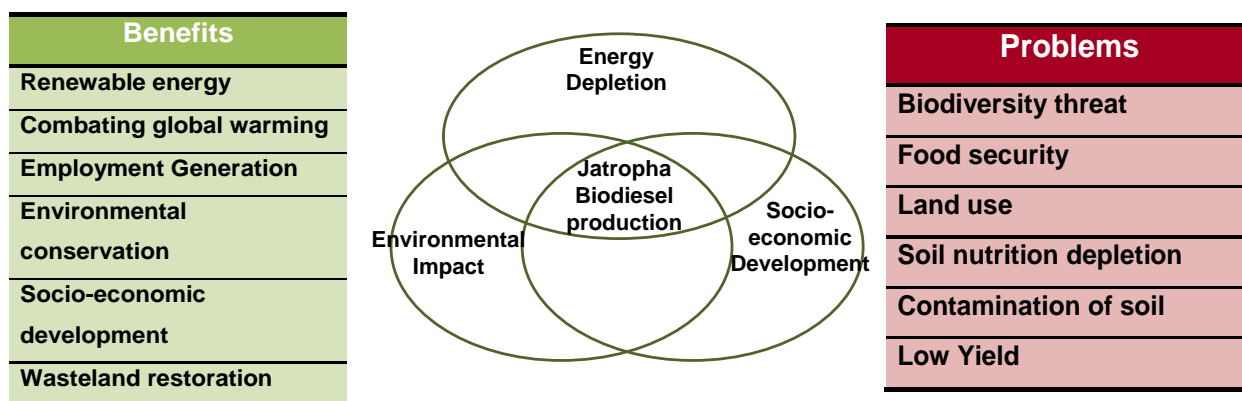

Figure 7 Jatropha Biodiesel sustainability issue

Furthermore, to avoid the shift along supply chain, sustainability should be assessed taking a system approach and considering the whole life cycle of biofuels, including cultivation, biofuel production and their use. Each stage in the life cycle is associated with several sustainability issues. These issues are listed in the Table 4 given below.

Table 4 Some sustainability issues in the life cycle of biofuels (Adapted from Azapagic and Stichnothe, 2010)

Environmental	Economic	Social
<b>Global warming potential</b>	Feed stock cost	Human health
<b>Land availability</b>	Investment cost	Human and labor rights
<b>Land use changes</b>	Biofuel price	Land ownership
<b>Biodiversity</b>	Local income generation	Food security
<b>Water consumption</b>	Industrial cost	Community development
<b>Resource depletion</b>	Revenue comparison	Impact on indigenous people
<b>Other environmental impacts</b>		Employment burden from industrial sector

- ✓ Global warming potential of biofuels

Estimated life cycle GHG emissions or global warming potential (GWP) from biofuels has been subjected to many LCA studies for the evaluation of biofuels vs. fossil fuels (Azapagic 2010). These GHG emissions of biofuels are usually compared on energy basis for most of the

studies where they use 1MJ of fuel as a functional unit for this purpose. Then GWP is estimated either in grams or kilograms of CO<sub>2</sub> eq. /MJ fuel.

✓ Land uses

It is a controversial issue associated with biofuels where the main concern is related to additional GHG emissions when the stored carbon is distributed and released. The direct land use involves conversion of existing land from a current use to cultivation of biomass feedstock for biofuel production. On the other hand the indirect land uses are associated with the displacement of current agriculture activity due to the biofuel producing crops. There are some cases found in the literature where the conversion of land to biofuel production can result in GHG emissions in a manner which can invert the potential benefits of biofuels.

✓ Other environmental impacts

The other impact vital for the sustainability of biofuel are; biodiversity, water uses, abiotic depletion, acidification, eutrophication, ozone layer depletion and toxicity etc. during the last 30 years the conversion to crop land is more than what happened in 150 year before 1950. This change in the agriculture and forestry has been the main cause of biodiversity. Intensified cultivation of biofuel crops could also lead to new pest and diseases, which could increase the use of pesticides and herbicides causing further environmental hazards.

Water is used throughout the life cycle of biofuels production. So far this use of water has not been intensively considered in LCA of biofuel sustainability. The main reason is the lack of data in this regard. Therefore it is not possible to draw the estimated use of water and its environmental correlation on a life cycle basis for sustainability measures.

LCA studies like ours mainly focus on GHG emissions, energy balances, resource depletion, acidification eutrophication, toxicity and ozone layer depletion. While biofuels can provide GHG savings, their other impacts can be higher than that of fossil fuels in this regard. For example the toxicity and eutrophication impacts are far higher than that of fossil fuels due to the use of fertilizers and pesticides. From this discussion it is very clear that for environmental sustainability of biofuel it is important for all relevant impact to be taken into consideration.

### *2.1.2.2 Economic and social sustainability of biofuels*

Economic assessments are not often available due to confidentiality and other financial issues. However there are studies which provide the estimates for economic and social viability of biofuel system (Azapagic and Stichnothe, 2010; Achten, 2010). For LCA the costs in economic viability includes cultivation cost, capital cost, labor and other utilities cost etc. higher biofuel prices currently makes this commodity attractive commercially. However this economic prospect/attraction only depends on the improvement of yields both in quantity and qualitatively manner.



Furthermore there are numerous social issues along with biofuel supply chain such as human health, labor rights, land ownership, impact on food security and community development etc. It is important to address social and other sustainability issues while this sector of biofuel production is still under development. In short, the further development of this biofuel sector depends on many technical, economic, environmental and social factors. For a worldwide sustainable biofuel sector, a well-defined action is required to ensure that the sustainability burden is not shifted from “developed to developing” country with a fair sharing of cost and benefits along its supply chain.

## 2.2 LIFE CYCLE ASSESSMENT

### 2.2.1 Introduction to life cycle assessment

Life cycle assessment is a “cradle-to-grave” approach for assessing industrial systems. “Cradle-to-grave” begins with the gathering of raw materials from the earth to create the product and ends at the point when all materials are returned to the earth. LCA evaluates all stages of a product’s life from the perspective that they are interdependent, meaning that one operation leads to the next. LCA enables the estimation of the cumulative environmental impacts resulting from all stages in the product life cycle, often including impacts not considered in more traditional analyses (e.g., raw material extraction, material transportation, ultimate product disposal, etc.) (Ortiz et al., 2009). The life cycle in the broadest sense includes several steps (product design, resource extraction, production, end use and re-use) and involves multiple streams, which can be of two types:

- The **elementary flow** that consist of flow exchanges with ecosphere i.e. the transections of primary resources (Fossil fuels and minerals) and pollutant emission (solid waste or gas emissions)
- The **intermediary flow** is a flow of energy and materials between different stages of life cycle.

By including the impacts throughout the whole product life cycle, LCA provides a comprehensive view of the environmental aspects of the product or process and a more accurate picture of the true environmental trade-offs in product selection and its associated process. The term “life cycle” refers to the major activities in the course of the product’s life-span from its manufacture, use, and maintenance, to its final disposal, including the raw material acquisition required manufacturing the product. Figure 8 illustrates the possible life cycle stages that can be considered in an LCA and the typical inputs/outputs measured (Curran, 2006).

Specifically, LCA is a technique to assess the environmental aspects and potential impacts associated with a product, process, or service, by:

- Compiling an inventory of relevant energy and material inputs and environmental releases
- Evaluating the potential environmental impacts associated with identified inputs and releases
- Interpreting the results to help decision-makers make a more informed decision.

When deciding between two or more alternatives, LCA can help decision-makers compare all major environmental impacts caused by their business activities. The following sub-sections discuss more about LCA, its background, methodology and engineering tools.

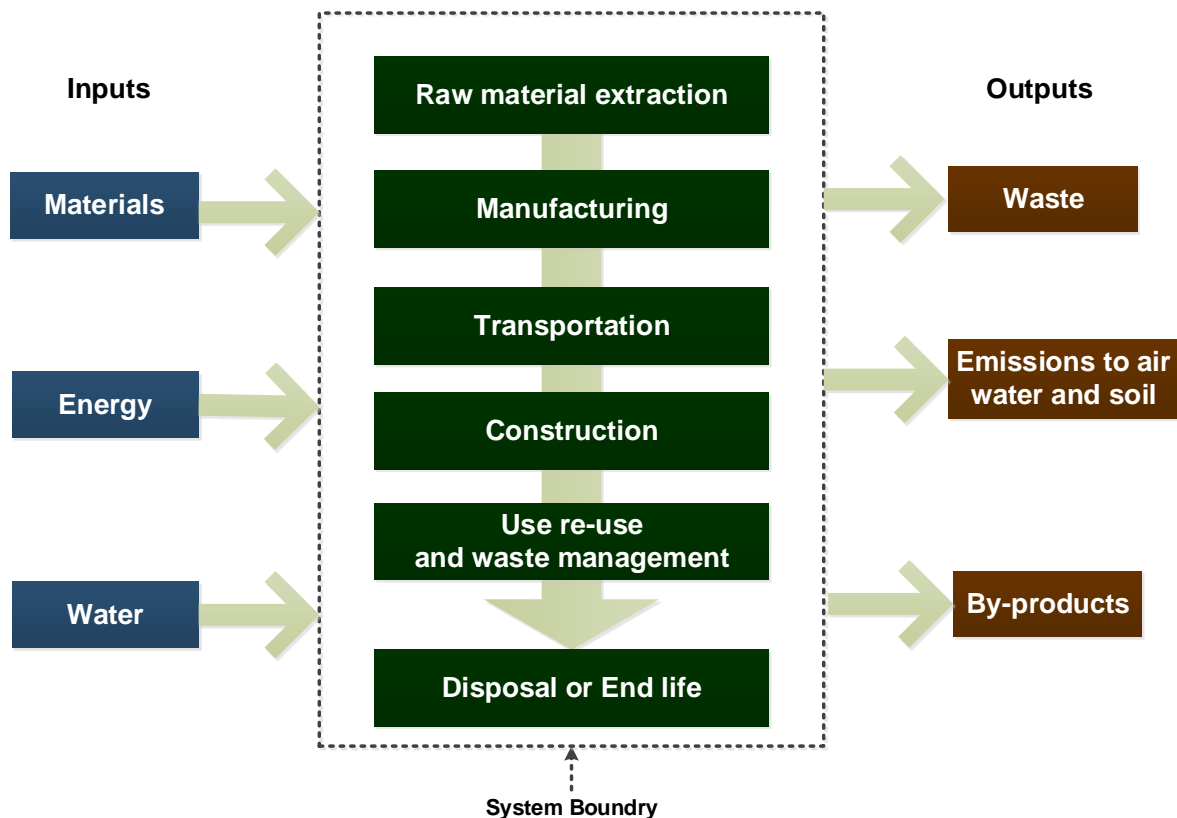

Figure 8 General overview of a product life cycle

Among the potential of LCA, it can be cited in the following areas:

- For an eco-design approach, taking into account environmental criteria during the design phase of a new product/process or a product/process already created for improvement.
- For an evaluation and improvement of product/process, the identification of critical areas on which it is possible to focus to optimize environmental performance.
- For a comparative approach, to know the value of products with the lowest impacts.

- For the implementation of industrial policy (choice of design / product improvement, selection procedures, etc...), Obtaining elements of decision support (choice of recovery processes, eco-labeling criteria, etc...).

This highlights the use of LCA and its interests for actors in various sectors (states, corporations, individuals, etc.), whether to make strategic decisions generally or specifically on ground. Similarly, it applies equally to the public sector and to the private sector as well.

### 2.2.2 *Background of LCA*

The first well-known LCA study was funded by Coca-Cola in 1969. Its purpose was to compare resource consumption and emissions associated with beverage containers (Curran, 2006). During the energy crisis, several studies were performed with an emphasis on energy. Before 1990, LCA studies dealt mainly with emissions and use of resources and were limited to technical systems (Bengtsson and Steen, 2000). During the early 1990s, several methods were developed to interpret the results of LCA studies in terms of environmental impacts. Some methods were also developed to weigh various impacts against each other. In the early 1990s, the practicing number of LCA experts increased considerably.

One reason for this expansion was the increase in computer software capable of handling the large amounts of LCA data. Another reason was the clear signal from governments to focus on products and initiate sustainable development. Since 1990, attempts have been made to develop and standardize the LCA methodology under the coordination of the Society of Environmental Toxicology and Chemistry (SETAC). In 1993, SETAC published a "Code of Practice", which presents general principles and a framework for the conduct, review, presentation and use of LCA findings (Consoli, 1993). An international standard for LCA put together by the International Standardization Organization (ISO) has recently emerged and is undergoing evaluation and revision (Azapagic, 1999; Lindfors et al., 1995). Azapagic (1999) has reviewed aspects of the ISO standards, and compared them with the SETAC methodology. The methodology framework for ISO is similar to that for SETAC with some differences for the interpretation phase, where ISO has included further analysis and sensitivity studies.

The ISO standards, recently produced or in draft form, are

- ISO 14040 (1997) covering LCA within environmental management for principle and framework
- ISO 14041 (1998) covering goal scope definition and inventory analysis
- ISO 14042 (2000) covering impact assessment
- ISO 14043 (2000) covering interpretation
- ISO 14044 (2006) this one has replaced the previous recommendations as it includes; definition of the goal and scope of the LCA, the Life Cycle Inventory (LCI) phase, the Life Cycle Impact Assessment (LCIA) phase, the life cycle interpretation phase, reporting and

critical review of the LCA, limitations of the LCA, relationship between the LCA phases, and conditions for use of value choices and optional elements.

There are other ISO standards that are related with different environmental aspects according to their goals. ISO 14064 parts 1, 2 and 3 are international greenhouse gas (GHG) accounting and verification standards which provide a set of clear and verifiable requirements to support organizations and proponents of GHG emission reduction projects. ISO 14031 provides guidance on how an organization can evaluate its environmental performance. ISO Guide 64 provides guidance for addressing environmental aspects in product standards. ISO 14067 on the carbon footprint of products provide requirements for the quantification and communication of greenhouse gases (GHGs) associated with products. ISO 14045 provide principles and requirements for eco-efficiency assessment. Eco-efficiency relates environmental performance to value created. ISO 14047 relate to Environmental management, Life cycle impact assessment and Examples of application of ISO 14042. ISO 14048 relate to Environmental management, Life cycle assessment and Data documentation format.

### 2.2.3 *LCA for Biodiesel*

Due to the rapid increase of fossil fuel prices, the depletion of energy and the awareness of the GHG effects, many countries have faced certain economic difficulties and environmental challenges. As a result, the developed countries have put their efforts on the development of renewable energy (solar energy, biomass energy, wind energy etc) as an alternative future fuel. Utilization of biomass to produce biofuel is another alternative to alleviate the energy needs for the transport sector and agriculture sector. Biodiesel is a renewable source of energy that can help reduce greenhouse gases emissions and minimize the “carbon footprint” of agriculture. It contributes less to global warming because the carbon in the fuel was removed from the air by the plant feedstock. In addition, biodiesel produces less air pollution (exhaust emissions) than diesel made from fossil fuels (Ndong et al., 2009; Sheehan et al., 1998).

The use of this renewable energy source is rapidly expanding its environmental sustainability and the role that its deployment can play in climate change mitigation has recently been called into question (Crutzen et al., 2007; Searchinger et al., 2008). Life cycle assessment (LCA) is one approach that enables the energy requirements, GHG balance and other impacts of bioenergy production chains (biomass and liquid biofuels) to be calculated, and should allow their accurate comparison. However, concerns have been raised that published data on energy and GHG balances of bioenergy show wide variability leading to conflicting conclusions on their environmental sustainability.

With increasing use of biomass for energy, questions arise about the validity of bioenergy as a means to reduce greenhouse gases emission and dependence on fossil fuels. Life cycle assessment (LCA) is a methodology able to reveal these environmental and energy

performances. Differences in the LCA variability as discussed above are due to several reasons: type and management of raw materials, conversion technologies, end-use technologies, system boundaries and reference energy system with which the bioenergy chain is compared. Based on review of published papers concerning greenhouse gases and energy balances of bioenergy, we are going to discuss in this section the key issues in bioenergy system LCA.

The potential environmental benefits that can be obtained from replacing petroleum fuels with biofuels and bioenergy derived from renewable biomass sources are the main driving forces for promoting the production and use of biofuels and bioenergy. There is a broad agreement in the scientific community that LCA is one of the best methodologies for the evaluation of the environmental burdens associated with biofuel production, by identifying energy and materials used as well as waste and emissions released to the environment; moreover it also allows an identification of opportunities for environmental improvement (Consoli, 1993; Lindfors et al., 1995).

Given the variety of processes leading to bioenergy, and the controversial discussion of their 'net benefit', several studies have already been undertaken using this methodology to analyse the processes in detail, in order to know which biofuels imply more or less environmental impacts (Heller et al., 2003; Quintero et al., 2008; von Blottnitz and Curran, 2007).

With the exception of a few studies, most LCAs have found a significant net reduction in GHG emissions and fossil energy consumption when the most common transportation biofuels (bioethanol and biodiesel) are used to replace conventional diesel and gasoline (Kim and Dale, 2002; von Blottnitz and Curran, 2007). Several LCA studies have also examined life cycle impacts on other environmental aspects, including local air pollution, acidification, eutrophication, ozone depletion, land use (as shown in the Figure 9), etc. (Farrell et al., 2006; Quirin et al., 2004). These environmental burdens are even more affected by site-specific assumptions than GHG and energy balances, showing that it is not easy to draw simplified conclusions. Studies that have examined these environmental issues have concluded that most, but not all, biofuels substituting fossil fuels lead to increased negative impacts (Larson, 2006; Zah et al., 2007). This applies particularly to bioenergy crops where, among others, the intensive use of fertilizers (compounds based on N and P) and pesticides can cause contamination of water and soil resources. Therefore, it should always be acknowledged that the positive impacts on GHG emissions may carry a cost in other environmental areas, so that a much more careful analysis is needed to understand the trade-offs in any particular situation.

From these studies it has been concluded that biodiesels can help to save the climate, but they are never climate neutral as many biodiesels have higher total environmental impacts than fossil fuels. In this case the type of biomass is more important than the type of fuel they

produces. However the use of waste product for fuel production makes a good sense as compared to those of fossil fuels.

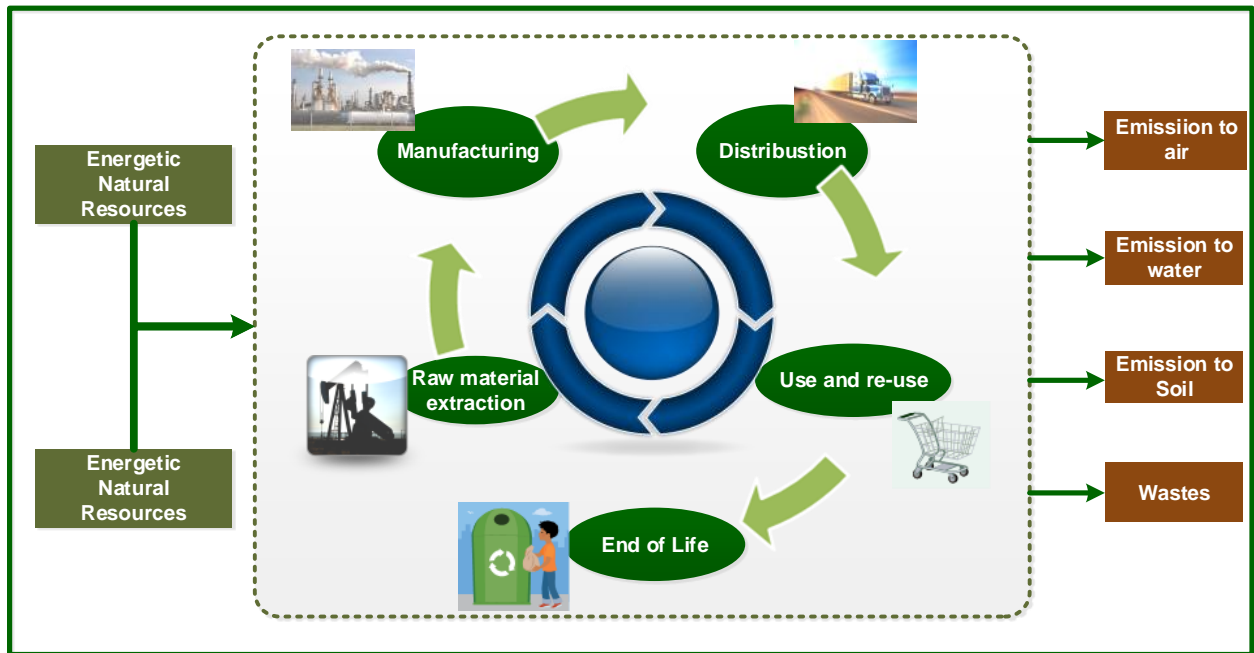

Figure 9 Global concept of LCA for biodiesel

#### 2.2.4 Different approaches towards LCA

Generally LCA are distinguished between two different approaches: “attributorial” and “consequential” LCA. Attributorial LCA is defined by its focus on describing the environmentally relevant physical flows for a life cycle and its subsystems. Consequential LCA is defined by its aim to describe how environmentally relevant flows change in response to possible decisions (Curran, 2006). Many authors have similar distinctions made in their publications (Ekvall and Weidema, 2004; Lundie et al., 2007).

Lundie et al., (2007) argue that consequential LCA should be used for decision-making; however, it is at the same time more relevant for increasing the understanding of the product chain and for identifying the processes and relations most important to improve. Ekvall et al., (2005), on the other hand, debated that attributorial and consequential LCA can both be used for decision-making and also for learning purposes. Consequential LCA is valid to assess environmental consequences of individual decisions or rules. Attributorial LCA, on the other hand, is valid for the purpose of avoiding connections with systems with large environmental impacts. According to Ekvall et al., (2005) both of these purposes are legitimate. As stated by several authors e.g. (Ekvall et al., 2005; Sandén and Karlström, 2007), attributorial and consequential LCA can both be applied for modeling of future systems. Both can also be applied for modeling of past or current systems.

The current use of non-renewable resources may have the effect that future generations have to use other resources with other environmental impacts (Stewart and Weidema, 2004). This has been the basis for several LCIA methods for resources (Goedkoop and Spriensma, 2001). However, as stated by (Weidema et al., 2005), if current resource use leads to changes in the environmental interventions of future extractions, this should be modeled in the Inventory Analysis, at least in a consequential LCA, and not in the LCIA. The choice between attributional and consequential LCA also influence system boundaries related to allocation and can influence other methodological choices, such as the definition of functional unit and the choice of LCIA methods (Rebitzer et al., 2004). The environmental consequences of a decision apparently depend on a variety of environmental, technological, and economic mechanisms. Different concepts, approaches, and models have been developed to describe and analyze different mechanisms. There is no uniform expertise or all in one tool in this regard. For this reason, a comprehensive consequential LCA may require not only a combination of tools but also a combination of experts. A consequential LCA is likely to be conceptually complex, because it includes additional, economic concepts such as marginal production costs, elasticity of supply and demand, etc. The distinction between attributional and consequential LCA is one example of how choices in the Goal and Scope Definition of an LCA should influence methodological and data choices for the LCI and LCIA phases. An attributional LCA was proposed for the case study of this particular research work keeping in mind the nature of study.

Another shortcoming of existing LCA methods are that either they do not consider the carrying capacity of ecosystems for providing the resources used in the life cycle or for absorbing the impact of emissions, or methods such as ecological footprint consider the bio-capacity, but only to a very limited extent (Zhang et al., 2010b). According to (Gutowski et al., 2009), the second law of thermodynamics indicates that no technological solution, as practiced currently, can lead to sustainability. This is because this law implies that decreasing entropy in a system must result in an even greater increase in entropy in the surroundings. This increase (disorder) often manifests itself as environmental impact. This does not necessarily imply that environmental impact can be estimated from the change in entropy since impact may involve further chemical and toxicological interactions, but simply that without the increase in entropy of the surroundings there cannot be any environmental impact. Since virtually all technological activities aim to create order in the form of manufactured goods and services, environmental impact is inevitable. This implies that no single technology, product or process can be claimed to be sustainable. In fact, it also implies that no individual technology by itself, that is available now or will be developed in the future, can lead to sustainability. This poses a severe dilemma for engineering research and technology development and conveys the futility of trying to develop a single technology that is sustainable (Gutowski et al., 2009). Technology does not exist in a vacuum, and for sustainability, the availability of its supporting goods and services must also be considered.

### 2.2.5 Sustainability through LCA

Multiple assessment techniques could be proposed and applied before evaluating the actual LCA, when lack of time and detailed information prohibit a full LCA. Initially it was elaborated that the possibility to satisfy simultaneously economic, social and environmental objectives is a rare one. But it is possible to define a tradeoff between these objectives, thanks to a multi-objective optimization (Alexander et al., 2000). Environmental risk assessment (ERA) is an interesting design tool for the improvement of existing processes. The general principle consists of estimating and evaluating risk to the environment caused by a particular activity or exposure (Burgess and Brennan, 2001), and then developing risk management in order to reduce the risks of harmful effects to society and environment (Olsen et al., 2001). Cost-benefit analysis is a totally different approach relative to the “environmental economics” field, consisting of evaluating project quality by estimating its “real economic value”. This means taking into account the economic value of any loss or gain of environmental quality in the costs and benefits evaluation of a project. Thus, the total value of a project is obtained by summing all market and environmental costs and benefits (Pearce et al., 2006).

Due to the ability of quantifying environmental interventions and the related impacts, LCA place itself naturally as a tool for assessing environmental sustainability. Because of these purposes LCA is termed as two directional: one is the identification of relevant environmental indicators for a specific system and other is assessment of its overall environmental sustainability, either for system development or for comparison with other referenced system. Example in this regard is LCA for biodiesel verses comparative LCA of biodiesel and fossil fuel. The use of environmental burdens as sustainability indicators is very much straight forward as they are calculated by carrying out mass and energy balances for the system under study. However replacing these with quantified impact categories as environmental indicators is much more complex.

The sustainability of a fuel product depends on its environmental, economic and social impacts throughout the product entire life cycle. The complete life cycle of the fossil or biodiesel production includes everything from raw material production and extraction, processing, transportation, manufacturing, storage, distribution and use. This causes various harmful impacts on the environment during its life cycle stages. So to achieve sustainability for fuel products and fuel system, one has to look back to the complete management of fuel chain “cradle to grave” from different perspectives. So in this study, LCA has appeared to be a valuable tool for sustainability concerns of biodiesel and also of other commodities. In our study of LCA application on a biodiesel production system, we have functional unit as a reference, for which the inventory and impact assessment results can be illustrated. This makes possible to compare our results with the results of reference products i.e. fossil fuel. Fossil fuel is often taken as reference product in the literature.



It should be noted that a life cycle study does not always need to use impact assessment. There are studies in which conclusions were drawn just on the basis of the results of the inventory phase. But inventory data are usually not enough for a decision maker regarding which fuel alternative is the best from the viewpoint of environmental aspects. We have three main areas which are responsible for almost all environmental impacts in our *Jatropha* biodiesel production system. These are;

- Manufacturing and use of fertilizers in the farming
- Farming activities to produce *Jatropha* seed
- Biodiesel production from *Jatropha* seed (includes Refining and Transesterification)

Acidification, eutrophication and toxicity are attributable to farming activity and fertilizer. Global warming is contributed by farming activity, fertilizer and biodiesel production. Ozone depletion and photo chemical oxidation mainly occurs in the biodiesel production stages. These three areas should be addressed in a proper scientific way for the sake of maximum system improvement.

Life cycle assessment is performed on systems on which we know all the materials and energy necessary to build a specific product. Biodiesel has been expected to substitute fossil fuel because of its renewability; however this may also raise the issue of environmental impacts. As already mentioned the use of LCA as a tool for assessing the environmental impacts of product, processes and activities related to them is gaining some good acceptance.

### **2.3 PROCESS SYSTEM ENGINEERING AND SUSTAINABILITY**

As mentioned in the previous section, LCA is now a well-established analytical method to quantify environmental impact for sustainable evaluation of products. However it has a great potential to couple with process system engineering for a sustainable development and analysis of process design (Jacquemin et al., 2012). PSE deals mainly with design, operation, control and optimization of processes along with systematic computer aided methods and tools which we termed as Computer Aided Process Engineering (CAPE). The present literature shows the need of inclusion for more environmental consideration in order to develop a more sustainable processes and industry. Therefore it is of great importance to adapt the LCA methodology for PSE or PSE for LCA and vice versa (Azapagic and Stichnothe, 2010; Grossmann, 2004).

In our research work we give an overview of PSE methods and tools coupling with LCA for developing a process product oriented LCA keeping in mind the sustainability criteria. This systematic integration of PSE tools for LCA help to provide more comprehensive results. PSE is a relatively young field of chemical engineering (i.e. about 35 years old). PSE develops methods and tools that allow industry to meet its needs by tying science to engineering (Grossmann, 2004), and encompasses a vast range of industries, such as petrochemical, mineral processing,

advanced material, food, pharmaceutical and biotechnological. PSE has to deal on a day to day basis with challenges like process design, process control, process operation, integration of new tools and methods etc. Due to these challenges, PSE has played an important role over the last decade by developing many useful concepts, tools and techniques for improving the viability of chemical related processes, making them more and more industrially feasible, e.g. the use of statistical signal processing techniques in process operation, or the optimization and use of artificial intelligence methods in process design.

The broadened definition provided by Grossmann and Westerberg, (2000) of PSE is “the improvement of decision-making processes for the creation and operation of chemical supply chain. This deals with the discovery, design, manufacture and distribution of chemical products in the context of many conflicting goals”. This definition encompasses the whole chemical supply chain (from the molecular to the company level) gradually led to the integration of safety and environmental factors as well as economics. Consequently, the emergence of environmental considerations and sustainability as a new industrial challenge assigned to PSE serves as an opportunity to play an important role, by modifying the design and operation of existing processes, and then developing new products and technologies that are designed according to environmental considerations. LCA application to industrial process analysis are not widespread, but it is becoming more and more attractive and important these days for developing a new enhanced integrated methods and tools like the one we have presented in our research work.

---

## 3. Definition and Historical Background of Biofuels

---

Biofuels are fuels produced from biomass, within a time frame sufficiently short to consider that their feedstock (biomass) can be renewed, contrarily to fossil fuels. This section reviews the current and future biofuel significance, its background and their development impacts within given policy and economic frameworks. Current technologies make it possible to provide first generation biodiesel, ethanol or biogas to the transport sector to be blended with fossil fuels. Still under-development 2nd generation biofuels from lignocellulose should be available in the market. Research is active on the improvement of their conversion efficiency. Compared with fossil fuels, biofuel combustion can emit less greenhouse gases throughout their life cycle, considering that part of the emitted CO<sub>2</sub> returns to the atmosphere where it was fixed from by photosynthesis in the first place. LCA is commonly used to assess the potential environmental impacts of biofuel chains, notably the impact on global warming. Given the available land areas, population growth rate and consumption behaviors, it would be possible to reach by 2030 a global 10% biofuel share in the transport sector, contributing to lower global greenhouse gas emissions.

### 3.1 PRESENT SCENE

Until the middle of the 19th century, American citizens lit their houses with whale-oil lamps. In 1892, the first Rudolf Diesel motor ran on peanut oil. Liquid fuels can be easily stored and transported and offer, for a given volume, a better exchange surface for combustion compared with solid fuels. Oils, in particular, can deliver a high energy amount by volume unit. No wonder then that biofuels were the first candidates to supply the newly developing automotive industry. However, they were almost immediately overtaken by petroleum products that appeared to be an energy godsend, remaining very cheap for more than a century. However, today the Black Gold Age is coming to an end. According to the Food and Agriculture Organization (FAO), the world population will grow from around 6.5 billion people today to 8.3 in 2030 (Bruinsma, 2003). World energy demand is expected to rise by some 60% by 2030. More than two-thirds of the growth in world energy use will come from the developing countries, where economic and population growths are highest. Fossil fuels will continue to dominate energy supplies, meeting more than 80% of the projected increase in primary energy demand. Global oil reserves today exceed the cumulative projected production between now and 2030, but reserves will need to be “proved up” in order to avoid a peak in production before the end of the projection period. The exact cost of finding and exploiting new resources over the coming decades is uncertain, but will certainly be substantial. Financing the required investments in non-OECD countries is one of the biggest challenges posed by energy supply projections (*World Energy Outlook 2005*, 2005). As an example, Saudi Arabia, with 25% of the world’s best proven reserves, is already investing US\$50 billion to increase its production capacity by 2 million barrels per day (Mb/d); the global worldwide current production averaging 86 Mb/d.

### 3.2 BIRTH OF BIOFUELS

At the very beginning of the automobile industry, petroleum and its other derivatives were not yet widely used in this sector. In 1876, Nikolaus Otto created the internal combustion engine to operate from ethanol. Later on, between 1893 and 1897, the German Rudolf Diesel invented the engine that bears his name, which ran with a fuel extracted from edible oil. Finally, Henry Ford designed an engine between 1903 and 1926 that run on ethanol. During the world wars I&II, cars adapted to work with steam rather than oil in order to cope with diesel or gasoline shortage.

Then the oil that was extracted from deep drilling in the mid-nineteenth century became cheap due to advances in drilling techniques, which shifted the consumers and industrial sectors from biofuels to fossil fuels. In 1973 and 1979, the two oil shocks i.e. increase in the cost of oil shattered everyone's interest, including the public authorities and research sector.

Many studies were conducted in the late 1970s and early 1980s. Same was the case for IFP (French Petroleum Institute), which at that time focuses on the transformation of vegetable

oils to methyl esters (biodiesel). Also in Brazil an extensive program was engaged for the ethanol production from sugar cane and its conversion to energy fleet. However, this enthusiasm for biofuel development was brought down by the reverse shock of lower prices of petroleum products in 1986. Once again in the 2000s, the new rise in oil prices, its production life and the threat to fight against the greenhouse effect and the unstable situation in some major oil exporters, revive the interest for biofuels. This can be illustrated by a speech by George Bush dated January 2006 in which the U.S. president announced that he wanted his country from 75% of the oil from the Middle East by 2025. The European Commission including its members wants to turn the share 5.75% for biofuel in their total fuel consumption by now. Finally, Sweden wishes to achieve energy independency by 2020. That's the reason that many countries are turning to biofuels these days.

It is important to note that for many years people were discussing about biofuels mainly for their ability to reduce emissions of conventional pollutants by the vehicle. However, this is no longer the case today due to many technological developments in combustion and smoke treatment for vehicles (catalytic converters, particulate filters). In the future, we use biofuels to reduce greenhouse gas emissions and our dependence on fossil fuel resources.

### **3.3 PRESENT SITUATION OF OIL PRODUCTION**

This part gives a brief idea of worldwide production of biofuels. Also the interest is to know the gross production of principle producers like USA, Brazil and some of the European countries as well.

#### **3.3.1 *Global situation***

We analyzed a world map by summarizing the total production of all countries. We note first that the United States and Brazil are by far the largest producers of biofuel from 2005 to 2012. It then notes that between 2005 and 2012, Europe has significantly closed the gap thus placing an honorable third place. However, for European Union it's a joint adventure as compared to other independent nations. For other countries such as Canada, China, India and Australia, their productivity in this regard is not very unidirectional except China.

They show a strong increase in output between 2005 and 2011, which suggests that this may continue in the future as well. Finally, we can highlight the fact that either the United States, Canada, Australia and European countries could be the major producers in biofuels or the new Industrialized Countries, as Brazil, China or India could emerge as major producers. The implication seems logical since it is highly industrialized countries that are affected by pollution and the desire to reduce it as well as the desire to be less dependent on fossil fuels. The production of biofuels (ethanol and biodiesel) exceeded 33 billion liters in 2004. That is 3% of 1200 billion liters of gasoline consumed on the planet. In 2009, global production of biofuels

has increased to a total of 92.8 billion liters against 84.7 billion liters in 2008, an increase of 9.6%.

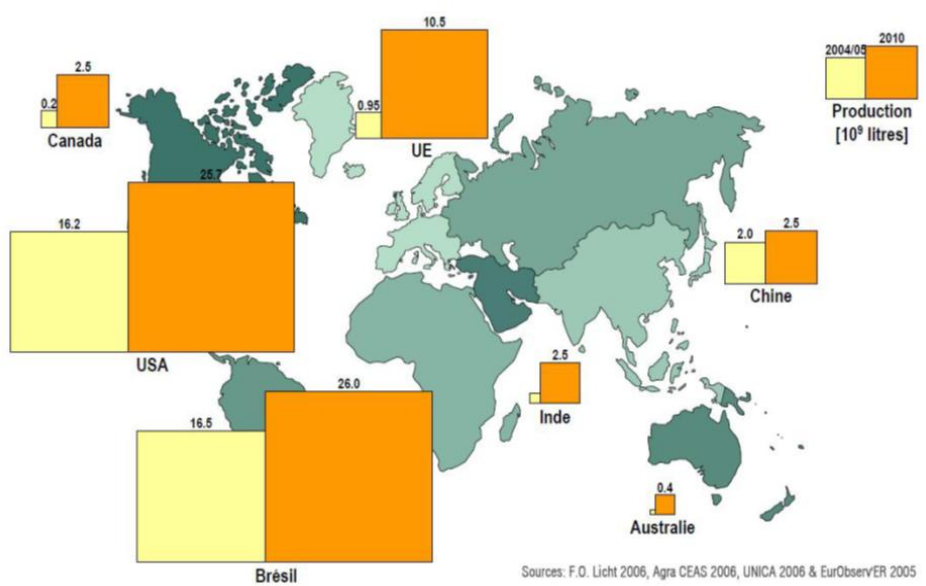

Figure 10 Map of bioethanol worldwide production

The United States and Brazil produce the greatest amount of ethanol, like about 41 billion and 26.3 billion liters respectively (Figure 10), which represents 88% of world production. Other producing countries are China, Canada, France and Germany, but none produced more than 3% of U.S. ethanol. While oil production worldwide has declined by 2.6% from 2008 to 2009, in which biofuels accounted for 2% of transport fuel, against 1.8% in 2008. According to an estimate, the European Union account 10% of world production of biofuels with a production of around 0.5 million tonnes.

### 3.3.2 USA situation

On October 13, 2010, the U.S. government announced its decision of increasing 15%, against 10% of incorporating authorized bioethanol in gasoline. This approval was supported and validated by Environmental Protection Agency (EPA), paving the way for a new fuel, "E15" and illustrates the proactive strategy of a nation where the entire fleet of gasoline vehicles runs with E10 and where already 8 million cars circulating with flex fuel. Due to this development the Americans are very reluctant to ratify the Kyoto Protocol and they are busy to find concrete solutions to the Copenhagen summit, where they are not fully bound to the fight against global warming.

### 3.3.3 Brazil Biofuel sector

Since the 1970s, Brazil had an edge over other countries in the automotive industry through its extensive program of development of ethanol from sugar cane. Today, they lead its way to alcohol fuel by rising oil prices. This domination of Brazil has increased with the advent of cars that can run either with alcohol or with gasoline, called bivalent car or auto Flex Fuel (for flexible fuel vehicles). Brazilians with flex-fuel cars have the choice facing the pump between gasoline and ethanol or can also refuel with any mixture of both of them. However, the major advantage of Brazil is that alcohol is cheaper than gasoline and, because of the sugar cane that grows easily and low wages demand.

### 3.3.4 Biofuel in European Union

In Europe, biofuel is mainly produced from oilseeds. Here we look at a map showing the biodiesel output across Europe. The first observation could be made on this card is that the biggest European producer is Germany (3255 MI) followed far enough by France (982 MI). Other Western Europe countries have productions level, which remain modest (about one to three hundred MI). In 2006, biodiesel production in the EU reached 6434 MI (approximately 60-65% of the annual world production). On this map only the large producers are highlighted. One can make the same remark as for the overall output but on a different scale to know that these are the most industrialized countries which produce biofuels. Figure 11 shows the relative percentage of biofuel production in EU for the year 2011.

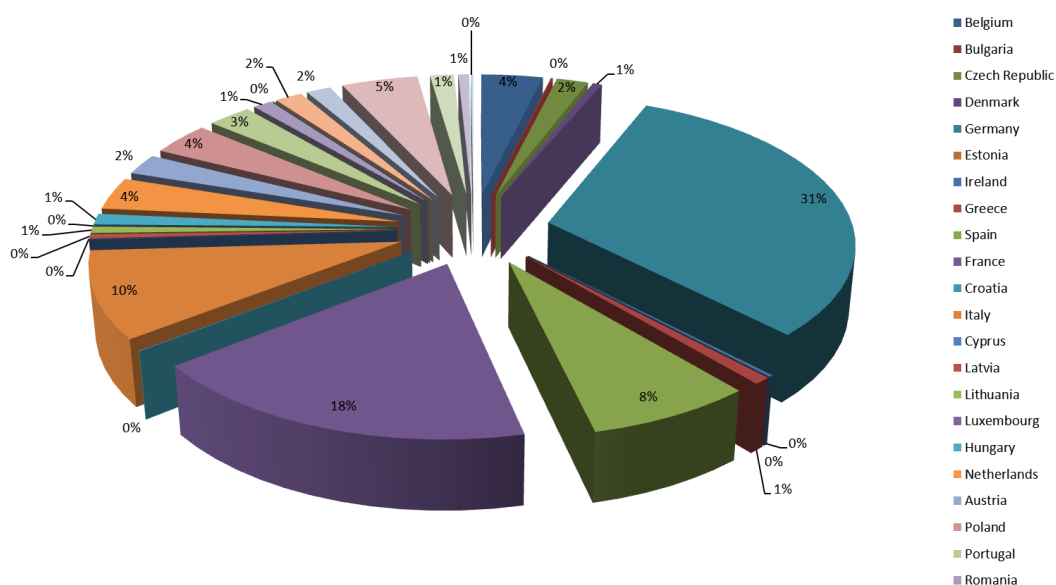

Figure 11 European Union biofuel production (source: Eurostat)

### 3.3.5 French Biofuel production

In France, the sugar beet is not as interesting as sugar cane in Brazil and also this is the main reason of Brazil development in biofuel production compared to France. However France has launched a project to produce biofuel from autotrophic microalgae, it is called "Shamash project." These microorganisms can accumulate up to 50% of their dry weight fatty acids; allow considering higher yields per hectare by a factor of 30 terrestrial species of oilseeds. This project began in December 2006 which consists of 8 teams and multiple French companies with a total budget of 2.8 million euros. According to European Union Figure 11 on the next page highlight the present situation of biofuel production.

## 3.4 DIFFERENT TECHNIQUES OF BIOFUELS

Energy commodities are either extracted or captured directly from natural resources (and are termed primary) such as crude oil, hard coal, natural gas, or are produced from primary commodities. All energy commodities which are not primary but produced from primary commodities are termed secondary commodities. Secondary energy comes from the transformation of primary or secondary energy. This section provides definitions of the key concepts of bioenergy, renewable, biofuels and their respective generations. Figure 12 provide a structured illustration of energy sources and their nature of renewability.

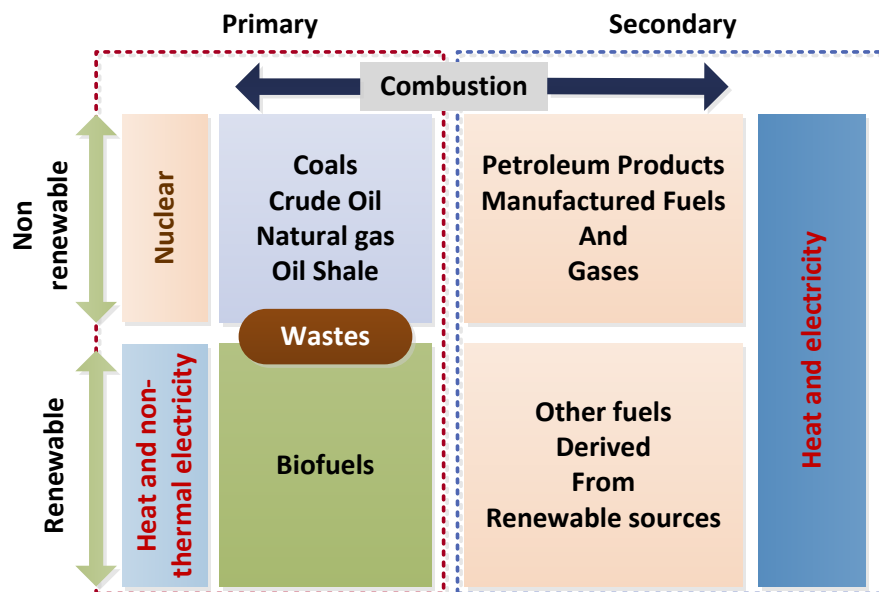

Figure 12 Terminology for Energy with their source of origin (Adapted from [www.iea.org](http://www.iea.org))

### 3.4.1 Bioenergy

Bioenergy is the chemical energy contained in organic materials that can be converted into direct useful energy sources via biological, mechanical or thermochemical processes. The most common and ancestral bioenergy source is firewood, which nowadays still represents 15% of global energy consumption (Bochu, 2007), some 90% of the world wood fuel being produced



and consumed in the developing countries (Parikka, 2004). Bioenergy come from biomass. In contrast, fossil energies are mineral resources, stocked in the lithosphere. The carbon fossil energy sources are the result of mineralization transforming organic matters into mineral matters. This transformation takes millions of years meaning that fossil resources are non-renewable on a human time scale.

### 3.4.2 *Renewable*

Renewable resources consist in two main types of natural resources: flow resources and renewable stock resources. Flow resources, like solar or wind energies, are non-limited resources despite intermittence. On the contrary, renewable stock resources, mainly biomass, are limited resources and their availability depends both on other primary natural resources (e.g. lands, water, ecosystems etc.) and on natural regeneration/degeneration rates and/or anthropic production/consumption rates. The term “renewables” in the energy field encompasses all energies coming from renewable resources, e.g. photovoltaic energy, wind energy, bioenergy etc. It is also referred to as Renewable Energy Sources (RES). Considering biomass, “renewable” indicates that it shall in theory stay available in an infinite time perspective as it can regenerate or be grown. However, in practice, the renewal of biomass also depends on its management, which should ensure that primary resources are not overexploited or even depleted. If resources management is technically appropriate, environmentally non-degrading, socially favorable and economically viable, then the renewable resource shall be exploited in a sustainable way. The issue of sustainability being crucial in the field of bioenergy, the UN executive board for clean development mechanisms released in December 2006 an official definition of “Renewable Biomass” including this sustainability dimension (UNFCCC, 2006). Among the five possible conditions where biomass can be defined as “renewable”, the three that do not deal with residues or wastes have a first criterion mentioning that the land use shall not change except if land areas are reverted to forest. The second criterion implicitly linked to the first one states: “Sustainable management practices are undertaken on these land areas to ensure in particular that the level of carbon stocks on these land areas does not systematically decrease over time”. This is a key element when comparing the CO<sub>2</sub> emissions from biofuels and fossil fuels. Indeed, the interesting fundamental carbon neutrality of combusted biomass relies on the fact that the emitted CO<sub>2</sub> from the plant originates from the atmosphere where it eventually goes back. If land conversion to biomass production implies additional CO<sub>2</sub> emission through soil organic carbon losses, it may offset this carbon neutrality.

### 3.4.3 *Biofuels*

They are biomass materials directly used as solid fuel or converted into liquid or gaseous fuels that can be stored, so that the harnessed energy can be released through combustion when needed. This chemical reaction permits to release the binding energy that holds electrons

to a nucleus in the organic molecules, in order to produce work and heat. In a narrower sense, biofuels may be only perceived as liquid or gas transportation fuels derived from biomass. Many different biomass raw materials can be used to produce biofuels including energy crops, agricultural residues or forest products for example.

Biofuels are nowadays commonly classed as 1st, 2nd or 3rd generation biofuels. First-generation biofuels refer to already considered as “traditional or conventional chains”, whereas 2nd generation biofuels, requiring more complex and expensive processes, are not available yet on the market. The energy efficiency of a biofuel chain must be appraised considering two aspects, both dependent on feedstock type: the net energy yield per area unit and the energy cost for transformation processes. When considering plant biomass, the energy yield per hectare is a function of the type of plant, the climate, the soil properties and the crop management. C4 plants, whose photosynthesis is more efficient, are especially energy cost effective in humid tropical regions where water is not limiting, e.g. sugar cane in Brazil. On the other end of the spectrum, maize in the US necessitates considerable energy inputs. There is among 1st generation biofuels no technological breakthrough that would lead to large differences in terms of energy efficiency. The following Figure 13 demonstrates the different generation along with their production chain and end product.

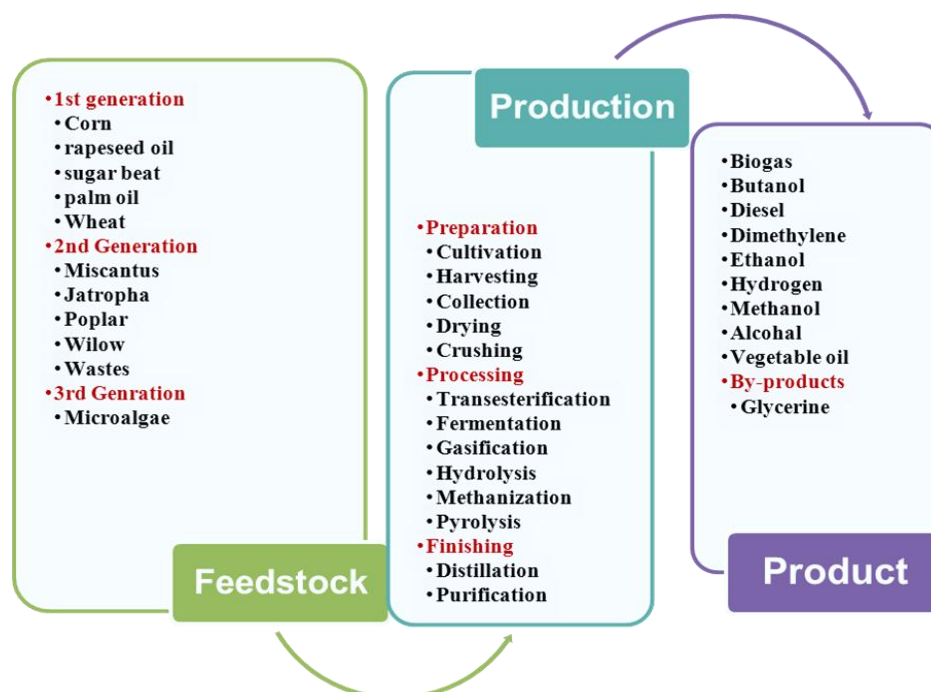

Figure 13 Overview of biofuel feedstock, processing and products

In temperate regions, oilseed crops typically generate lower yields per hectare than sugar or starch crops and are therefore more expensive to produce. But because oils seeds require less processing they still generally have positive global energy balances per unit of feedstock.

Oilseed crops grown in tropical areas can thus be especially productive and competitive. Globally feedstock cost account for the majority of a 1st generation biofuel's eventual price, while processing costs and a small proportion for transport represent most of the rest. For ethanol, feedstock comprises 50 to 70% of the production cost, while for biodiesel feedstock can be 60 to 80% of the production cost (Hunt, 2006; Lang, 2001). The split between 1st and 2nd generation biofuels lies on the fundament that the last ones are produced from lignocellulose, meaning that all types of vegetation and all parts of the plant are possible feedstock, whereas 1st generation biofuels only up-value specific parts of a few suitable plants. Hence 2nd generation biofuels yield higher energy amounts per hectare than energy crops with proportional small specific organ of interest (such as seeds) as no part of the plant is left over. They also encompass a wider range of possible feedstock. Third generation biofuels are the follow-up of 2nd generation biofuels, from the same raw material up to H<sub>2</sub> production, whose energetic costs remain out of reach.

Each generation of biofuel is further discussed in detail in the appendixes 15.1 at the end of manuscript.

### **3.5 CURRENT BIOFUEL ISSUES**

There are several reasons for biofuels to be considered as relevant alternative for technological uses both by developing and industrialized countries. They include energy security reasons, environmental concerns, foreign exchange savings, and socioeconomic issues related to the rural sector. But at the same time there are certain issues related to the production and use of biofuel as well and these issues are highlighted in this section.

#### **3.5.1 *Environmental issues***

Recently biofuels producing crops have been fostered worldwide in a double context of energy insecurity and climate change. Except for a few exceptional cases, such as the reference Brazilian Pró-álcool Program launched in 1975, it was not until the awareness on the risks associated with the depletion of fossil resources was drastically raised that biofuels and other renewables were widely given attention as real potential energy sources. Since the late 1980s, the more explicit the conclusions of the Intergovernmental Panel on Climate Change on the reality of climate change and the impact of anthropogenic greenhouse gas emissions have become, the more concrete the international policies and instruments to promote renewables have appeared. Needs for action and cooperation were expressed within the frame of international agreements; such as the United Nation Framework Convention on Climate Change (UNFCCC) in 1992. Although it might not have federated enough stakeholders, which only entered into force in 2005 without some of the main CO<sub>2</sub> contributors, they gave way to the establishment of effective frameworks and national action plans.

The global average surface temperature on the Earth increased about 0.7°C between the late 1800s and 2000, with a rate of about 0.2°C per decade (Susan, 2007) in the past three decades. However, taking into account the effects of orbital variations on climate, absent human influence, the natural trend would be toward a cooler climate, as peak warmth of the current interglacial period (Holocene) occurred 8-10 thousand years ago. Examination of prior interglacial periods reveals a strong correlation between the CO<sub>2</sub> and CH<sub>4</sub> concentrations in the atmosphere and temperature records. Nevertheless, in the past the temperature changes usually preceded the changes in gases concentrations. Today, anthropogenic greenhouse gas emissions are overwhelming and the order was reversed so that greenhouse gases are driving temperature increases. Climate system has not come to equilibrium with today's climate forcing and more warming is "in the pipeline" as humans tends to control global climate, for better and worse scenarios (Hansen et al., 2011). In other words, the IPCC stated in its last report: Most of the observed increase in global average temperatures since the mid-20th century is very likely (probability >90%) due to the observed increase in anthropogenic greenhouse gas concentrations. Discernible human influences now extend to other aspects of climate, including ocean warming, continental-average temperatures, temperature extremes and wind patterns (Pachauri, 2008). Preindustrial global atmospheric concentrations of CO<sub>2</sub>, N<sub>2</sub>O and CH<sub>4</sub> have increased markedly as a result of human activities since 1750 and now far exceed pre-industrial values determined from ice cores spanning many thousands of years.

Global increases in CO<sub>2</sub> concentration are due primarily to fossil fuel use and land use change, while those of CH<sub>4</sub> and N<sub>2</sub>O are primarily due to agriculture. If CO<sub>2</sub> emissions continue to increase per 1.5 to 2% per year, doubled-CO<sub>2</sub> will be reached in approximately the year 2050. Encompassing the whole range of the six IPCC emissions scenarios from the lowest to the highest emissions, global warming could reach 1.8 to 4°C by 2100 (Pachauri, 2008). A global warming of 2 to 3 °C over the pre-industrial temperature would already make the Earth a different planet (Hansen et al., 2011). As a very critical issue, sea level rise illustrates how climate change can lead to exponential and irreversible impacts due to accumulation phenomena and positive feedbacks. IPCC scenarios give estimates of a sea level rise between 38 cm and 59 cm by the end of the 21st century relative to 1980-1999, due mostly to thermal expansion and excluding future rapid dynamical changes in ice flow. There is still no consensus on the long term future of the ice sheet or its contribution to sea level rise. It is not possible to say how long it would take sea level to change as feedbacks can lead to non-linear responses.

Nevertheless, "it is almost inconceivable that under business-as-usual scenario climate change would not yield a sea level change of the order of meters on the century timescale" (Hansen et al., 2011). Given the populations in 2000, a sea level rise of 6 m would displace 35 million of inhabitants throughout the world and trouble is brewing for many species. The distance that climate zones have moved so far is small, but the rate of movement of isotherms is now pole-ward at 50 km per decade and will double this century if we follow the business-as-

usual scenario, surely causing the extinction of lots of species (Hansen et al., 2011). The IPCC stresses that: "Continued greenhouse gas emissions at or above current rates would cause further warming and imply many changes in the global climate system during the 21st century that would very likely be larger than those observed during the 20th century. Sea ice is also projected to shrink in both the Arctic and Antarctic. It is very likely that hot extremes, heat waves and heavy precipitation events continue to become more frequent. Even if the concentrations of all greenhouse gases and aerosols had been kept constant at year 2000 levels, a further warming of about 0.1°C per decade would be expected (Pachauri, 2008).

Together, the 25 countries with the largest greenhouse gas emissions account for approximately 83% of global emissions. The largest emitter is the United States, with 21% of global emissions, followed by China with 15%. It follows that most of the remaining countries contribute little to the build-up of greenhouse gases in the atmosphere; 140 countries contribute only 10% of annual emissions (Baumert et al., 2005). Emissions growth rates are highest among developing countries, where collectively CO<sub>2</sub> emissions increased by 47% over the 1990 to 2002 period. Among the major developing country emitters, growth was fastest in Indonesia (97%), South Korea (97%), or Iran (93%). During the same period, emissions also increased mainly in Canada (+20%) and Australia (+22%), whereas emissions in most developed countries did not change. During the 2003–2004 period, the CO<sub>2</sub> growth of 50% in China accounts for more than half of the worldwide CO<sub>2</sub> increase.

### 3.5.2 Socio-economic issues

Biofuel production increases the demand for agro-products in two ways:

- Competition with food products

With the possible relocation of its production and supply to the industry, many believe that it could lead to the higher food prices and shortage of food along with other social consequences. Some, like Jean Ziegler, former United Nation observer on the right to food, consider that any agricultural production must, in principle, be food to keep prices as low as possible, or risk serious social consequences. Proposing to the United Nation a five-year moratorium on biofuel production, he said that "fertile agricultural land devoted to food production which is then converted for biofuel production is a crime against humanity."

- Land uses and hike in the price of agriculture commodities

In addition to the current reduction in arable land, the prospect of new lands deforested (with the risk of erosion above) or existing land withdrawn from food production to biofuel production critics. Yet it was a goal of producing biofuels finds an outlet for a production that was not up on a farm market depressed in terms of price. But "the image of the mountains of butter, meat and cereals stored without hope of finding buyer belongs to the past". And the

European Commission has decided to abolish quotas and set-aside of the common agricultural policy.

In general, the development of agriculture at the expense of natural areas, poses environmental problems. For example, in Indonesia, the development of the production of palm oil for the food industry and organic chemistry, ancient forests were burned (burning sometimes for months) to be converted to farmland (soils of Indonesia for 60% of global peat). Taking into account these releases, Indonesia would become the third largest emitter of carbon after the United States and China. Demand for biofuels would contribute to the massive human colonization of all areas of space. However, biofuels are not the main driver of this development and abandonment is not enough to prevent it.

After a long period of decline, food prices rose sharply, and biofuels have been accused of being the cause for this rise in the price. For example, the price of tortillas, a staple food in Latin America, has soared in Mexico: the Mexican government had put the blame on maize exports to the USA where it is used to produce ethanol, even if the prices of the Mexican tortilla is mainly due to economic and political context (monopolistic position of the main producer of tortillas in Mexico and price liberalization, previously set by the state). Biofuels have played a role, it was also one of the goals of this policy to provide an outlet for agricultural production and thus maintain prices. However the chain of causes is more complicated and plays many other factors.

For example, according to a World Bank report on the evolution of food prices between 2002 and 2008, nearly 75% of their gains were due to speculative financial movements using biofuel support policies in the European Union and the United States (Aksoy and Ng, 2010). These financial transactions have scared many developing countries who then banned the export of food products, in turn leading to escalating prices. The remaining increase was primarily due to higher oil prices. Based on the fact that the program of development of biofuels in Brazil has not led to higher prices, the report recommends the removal of support policies for biofuels as well as the barriers preventing the importation of biofuels Africa and South America as a way to combine biofuels and stability of world agricultural prices.

Stephan Tangermann, Director of Agriculture in OECD (Organization for economic cooperation and development) tempers this analysis because he believes it is “very difficult to measure the percentage of all factors on prices” however he states that “It is certain, it is that 60% of the increase in global demand for grains and vegetable oils between 2005 and 2007 was due to biofuels” (Sumner and Tangermann, 2002). This increase can affect the prices of other agricultural products. The Deutsche Bank experts believe that this will be the case for beef (cattle are fed corn). In Germany, where 16% of the area of land currently used for the production of biofuels, the price of malt doubled in 2006, resulting in an increase in the price of beer.

### 3.5.3 *Geostrategic issues*

Different pathways for biofuels can be drawn in order to stimulate the agricultural activity. In the recent times many farmers has ask the government help due to the production of surplus amount of food product and their low prices. This simulation causes a condition for agricultural market to reverse its production which is not a good sign for biofuels. It is at this stage that recently a dialogue, debate and confrontation regarding biofuels have been facilitated which allows for the development of new technologies and refineries to produce them. Such importance is not only the result of a sudden leap in scientific knowledge, although that has taken place, but rather it is a leap in governments funding, which seem concerned about oil prices rising and geostrategic dependence on them. Whatever the reason, if funding continues, in the short term a new generation of biofuels could be available. Despite the enthusiasm, promotion and advocacy, there is a question: are biofuels a technical and economically viable energy and environmental option for replacing future fuel imports? But at the same time with the promotion and incentives (legal, regulatory, fiscal and financial framework), of alcohol fuels and bio-oils, employment rates see a positive impact in farming regions. It is necessary not only to encourage biofuels production but also define programs that support the new refineries' biomass needs, so that the price of raw materials with dual purpose (food and biofuel) is not affected.





---

## 4. Jatropha overview for biodiesel production

---

In a context of growing interest for renewable energy sources, liquid bioenergy production from vegetable oils is proposed as one of the possible options to reduce greenhouse gas emissions. Against this background, biodiesel production from *Jatropha curcas L.* has become a booming business. This section presents a literature review of the whole *Jatropha curcas* biodiesel production process and use.

## 4.1 JATROPHA OVERVIEW

There are more than 350 oil-bearing crops identified and a wide number of them and common plants have been studied around the world for the past years (Demirbas, 2007). Recently, *Jatropha curcas* L. (JCL) has drawn attention. This plant was discovered by Portuguese sailors in the 16th century which was then spread over Africa and Asia. *Jatropha curcas*, also known as Physic nut belongs to the Euphorbiaceae family. This is commonly grown in the tropics as a living fence. Nowadays it is distributed penatropically, which gives rise to identification of different accessions. It is adapted to arid and semi-arid conditions and higher temperatures, occurring mostly in seasonally dry areas. Its introduction has been successful in drier regions of the tropics with an average annual rainfall of between 300 and 1000 mm, (Achten et al., 2008) but can also be found in regions with damp tropics. *Jatropha* prefers lower altitudes, well drained soils with good aeration (heavy and clayish soils prevent best root formation) and is adapted to marginal lands with low nutrient content (Achten et al., 2008; Heller et al., 2003).

*Jatropha* plant grows as a large shrub or small tree, up to 6m. It has flowers and is deciduous; shedding with the help of its big leafs in the rainy season. Flowering time takes places during the hotter seasons. The flowers pollination is entomophilic and the resulting fruit is trilocular and ellipsoidal and usually develops during the winter period. The exocarp maintains moisture content until the three black ovoid oily seeds mature. The ripped seeds are blackish brown and long ovals with a very hard outer shell in its shape. The seeds represent between 65% of the fruit dry weight and when pressed, they produce oil traditionally used for soap making. The cakes produced through pressing (oilcake) are used as an organic fertilizer for agriculture fields. Neither the *Jatropha* oil nor the cake is edible due to the toxic and anti-nutritional substances they contain. Recently *Jatropha* has been produced of on industrial scale in Asia and Latin America (Renner et al., 2008). Figure 14 and Figure 15 gives a picture of *Jatropha* plant and produced seed.



Figure 14 A three years old *Jatropha* plant (Source: CIRAD)



Figure 15 Seeds of *Jatropha* (Source: CIRAD)

#### 4.1.1 Cultivation

The cultivation of *Jatropha* was considered to be the first stage of biodiesel production. Resources from experimental research site of Mali West Africa were used to obtain all the valid information regarding cultivation of *Jatropha*. As already mentioned *Jatropha* is a wild plant with wide phenotypic variation, reliable field data is needed to set input levels (Achten et al., 2008). Seedling and vegetative propagation through branch cutting are the ways to reproduce *Jatropha* plants. Some suggest the use of seedlings from nurseries seems to enhance cultivation's success as nurseries provide necessary control of environmental factors and allow production of healthy seedlings (Kaushik et al., 2007). In nurseries fertilizers along with pesticides are used in order to get healthy and well established plants. Large scale cultivation of *Jatropha* requires irrigation both in nurseries and in different stages of plant production. *Jatropha* has been tested at different level of irrigation in several studies and in our case we observed the amount of 0.2 to 0.5L of water required by per plant per day. *Jatropha* has low moisture requirements but irrigation can bloom the yield. Different quantities of fertilizer N-P-K are applicable in different phase of *Jatropha* plant establishment. The caretaker should monitor the seedling's quality to keep uniformity at best available quality amid the plantation. The use of good available seeds is preferable in order to gain high yield (Gour, 2006). Moreover, this also helps in increased oil content which may be the most important traits in the case of *Jatropha* as an energy crop (Mishra, 2009).

Trimming is done almost first year onwards in order to shape the plant for enhanced branch formation. Additional operations include weeding and hoeing of the plants basin, especially during the establishment period has to be carried out (Kaushik et al., 2007). This plant was thought to be toxic enough to overcome the issue of parasitism but this has been proved wrong since there are some species that find nutrients in *Jatropha*. Many researchers have observed pests and diseases of several types associated with *Jatropha* plant and seeds like powdery mildew, flea beetles and millipedes etc. Till now no widely spread diseases have yet been registered but this is going to be changed with commercial plantations and emergence (Dias et al., 2007; Shanker et al., 2006).

A *Jatropha* plant takes approximately three years to start yielding (Ndong et al., 2009). However, some authors state that plants raised from seeds take up to 4 years to yield seeds (Sunder, 2006). It was assumed in general that stable yields start at 4th year onwards of cultivation (Kaushik et al., 2007). A stable figure for plantation yield is missing. This is due to the lack of systematic analysis. Data in this regard ranges from 2 to 7 tons of dry seed  $\text{ha}^{-1} \text{yr}^{-1}$  (W. M. J. Achten et al., 2010a). In harvesting stage, mature seeds could be distinguished by the dark brown and yellow color. Manual collection is followed by drying of fruits. This drying can be done naturally or mechanically and next drying stage there is seed removal. Figure 16 gives a picture of *Jatropha curcas L.* cultivation i.e. plantation field on the left and nursery on the right.



Figure 16 *Jatropha curcas L.* cultivation: plantation field (source: [www.biofuelsdigest.com](http://www.biofuelsdigest.com))

#### 4.1.2 Global production of *Jatropha*

In 2008, *Jatropha* plantations stretched over 900 000 hectares worldwide, including 760,000 in Asia, 120,000 in Africa, 20,000 in Latin America. But according to the Food and Agriculture Organization (FAO) and the International Fund for Agricultural Development (IFAD), they could reach 12.8 million hectares worldwide by 2015. The largest producing countries are Philippines and Indonesia in Asia, Ghana and Nigeria in Africa and Latin America. Figure 17 on the next page highlight the surface for *Jatropha* production country wise.



Figure 17 Cultivated surface in the world for *Jatropha* production (Source: *Jatrophabook.org*)

#### 4.1.3 Botanical description

*Jatropha* or Physic nut is a small tree or large shrub, up to 5-7 m tall, belonging to the Euphorbiaceae family, with soft wood and a life expectancy of up to 50 years. The plant has its native distributional range in Mexico, Central America, Brazil, Bolivia, Peru, Argentina and Paraguay, although nowadays it has a penatropical distribution (Heller et al., 2003) with distinct *Jatropha* seed provenances. The plant develops a deep taproot and initially four shallow lateral roots (Heller et al., 2003). The taproot may stabilize the soil against landslides while the shallow roots are alleged to prevent and control soil erosion caused by wind or water, but this potential has not been investigated scientifically. The leaves are smooth, 4-6 lobed and 10-15 cm in length and width. The plant is monoecious and the terminal inflorescences contain unisexual flowers. The ratio of male to female flowers ranges from 13:1 to 29:1 and decreases with the age of the plant (Pandey et al., 2012). Normally *Jatropha* flowers only once a year during the rainy season (Raju and Ezradanam, 2002). After pollination, the inflorescences form a bunch of green ellipsoidal fruits (Kumar Tiwari et al., 2007). The blackish seeds of most provenances contain toxins, such as phorbol esters, curcin, trypsin inhibitors, lectins and phytates, to such levels that the seeds, oil and seed cake are not edible without detoxification e.g. (Makkar and Becker, 2009; Martinez and Kafarov, 2012).

#### 4.1.4 Seed production

For best oil yields, the seeds should be harvested at maturity. Seeds are mature if the color of the fruits has changed from green to yellow-brown. Maturity is reached 90 days after

flowering (Heller, 1996), but the fruits do not mature all at the same moment. As such the fruits have to be harvested manually at regular intervals (Heller, 1996; Kumar and Sharma, 2008), making this step very labor intensive. The moment and length of harvest period is likely to vary according to the seasonal conditions of the locality (Kaushik et al., 2007). In semi-arid regions the harvest is spread over a period of two months which implies daily or weekly harvests. In permanent humid situations weekly harvest can be necessary all year through. Separation of the seeds and husks can be done manually or mechanically (Gour, 2006). *Jatropha* seed yield is still a difficult issue. Actually the mature seed yield per ha per year is not known, since systematic yield monitoring only started recently. At present the effect of spacing, canopy management and crown form and surface on the yield is not known, making it impossible to make such extrapolation. Yield depends on site characteristics (rainfall, soil type and soil fertility) (Francis et al., 2005; Openshaw, 2000), genetics, plant age (Gour, 2006; Heller, 1996; Kumar and Sharma, 2008) and management (propagation method, spacing, pruning, fertilizing, irrigation, etc.) (Ariza-Montobbio and Lele, 2010; Gour, 2006; Heller, 1996). Information on these yield influencing variables was generally not reported alongside. *Jatropha* has not yet undergone a careful breeding program with systematic selection and improvement of suitable germplasm, which is why it can still be considered a wild.

## **4.2 BIODIESEL PRODUCTION FROM JATROPHA**

The two main methods for extracting the oil from the seeds is pressing or solvent extraction (commonly with hexane). For quality yield postharvest management is very important which includes different aspects like seed grading and storage and pruning (Gour, 2006). The seeds are transported to the destinations where the oil extraction could be done. Oil extraction is usually carried out through cold pressing with the help of electric screw pressers. Crude *Jatropha* oil requires refining before the introduction of transesterification, depending on seed quality. Through transesterification oil is being converted into the *Jatropha* methyl ester. The yields differ, being much higher with solvent extraction. Likewise, such is the most energy and input expenditure process and only large amounts of seeds seem to justify its use (Adriaans, 2006). He points out that press attained *Jatropha* oil has satisfactory quality so that there is no need in using underdeveloped and environmental hazardous solvent extraction methods. Meanwhile, other oil extraction procedures are being developed including as enzyme or supercritical fluids-supported (Achten et al., 2010b). Shah et al., (2005) added ultrasonic use to the process and increased yields up to 74% in half the time. Crude *Jatropha* oil requires refining prior to transesterification, depending on seed quality.

The first pre-treatment step is degumming which consists of heating the oil and adding water and phosphoric acid (Prueksakorn et al., 2010). Degumming depletes phosphorus content through removing phospholipids (Roy et al., 2009). Fuel is selected from the distillate, dried and again heated with sodium hydroxide for free fatty acid neutralization. Chemical requirements depend on gum and free fatty acid content of the oil. Several studies have analyzed the transesterification of *Jatropha curcas* oil. They corroborated the suitability of the resulting biodiesel use for diesel engine combustion proven as it is that its physico-chemical properties fit in European and American quality standards (Kumar Tiwari et al., 2007; Lu et al., 2009; Oliveira de et al., 2009; Sahoo and Das, 2009). For quality yield postharvest management is very important which includes different aspects like seed grading and storage and pruning (Gour, 2006). The seeds are transported to the destinations where the oil extraction could be done. Oil extraction is usually carried out through cold pressing with the help of electric screw presses. Crude *Jatropha* oil requires refining before the introduction of transesterification, depending on seed quality. Through transesterification oil is being converted into the *Jatropha* methyl ester (JME). Figure 18 provides a complete cycle of *Jatropha* biodiesel production which starts from nursery development till final use in the form of biodiesel.

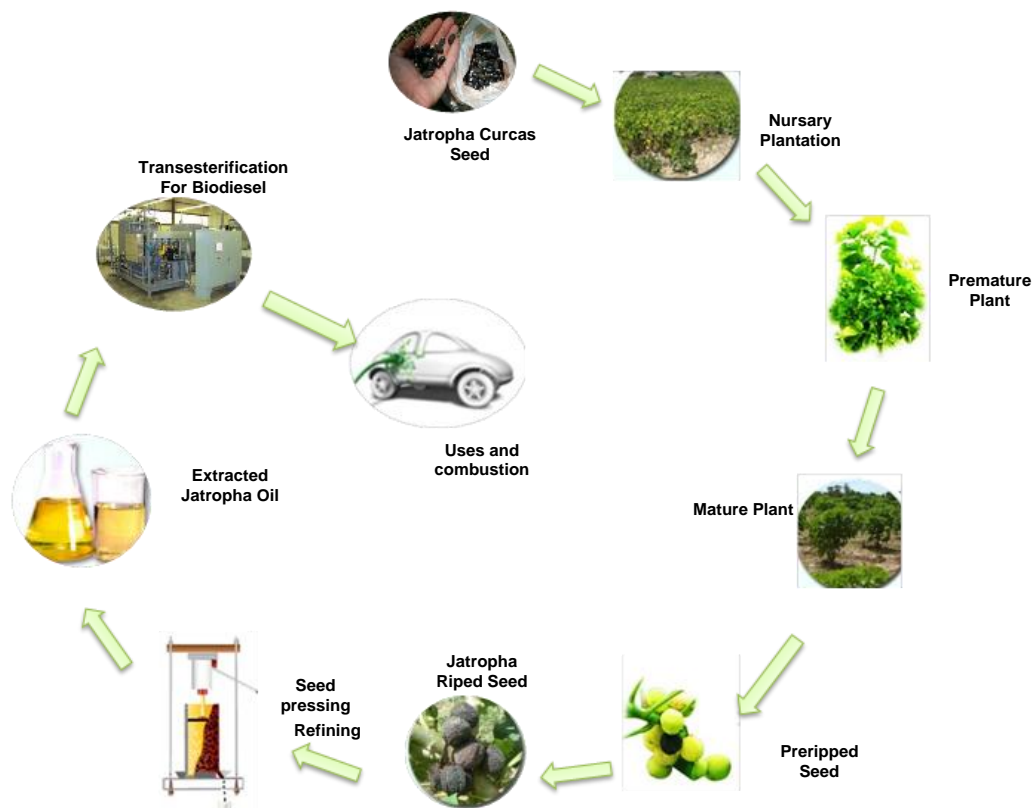

*Figure 18 Jatropha biodiesel production cycle*

Biodiesel production by transesterification reactions needs a catalyst. This catalyst can either be an alkali (typically KOH, NaOH) compound, an acid (H<sub>2</sub>SO<sub>4</sub>) or an enzyme. Yet, Wang et al., (2007) highlighted that the first two types of catalysis require a shorter reaction time and a lower cost compared to the enzymatic catalysis. Nowadays, most of the produced biodiesel are base (alkali) catalyzed mainly because it involves milder operating temperature and has a higher conversion rate (up to three order of magnitude greater than acid-catalyzed reaction) (Om Tapanes et al., 2008). The different steps of the alkali-catalyzed transesterification and the mechanisms that come into play are going to be presented here. Literatures regarding transesterification of *Jatropha curcas* oil are available in numbers. (Kumar Tiwari et al., 2007; Oliveira de et al., 2009; Om Tapanes et al., 2008).

#### 4.2.1 *Transesterification process*

Biodiesel is produced through the so-called transesterification process, in which *Jatropha* oil is combined with alcohol (ethanol or methanol) in the presence of a catalyst (e.g. potassium hydroxide) to form ethyl or methyl ester. The transesterification process requires steam and electricity as energy inputs and produces both JME and glycerin. The process parameters were taken from Whitaker et al., (2009).

Recently biodiesel has gained importance for its ability to replace fossil fuels which are running in crisis situation these days. The environmental issues concerned with the exhaust gases emission by the usage of fossil fuels also encourage the usage of biodiesel which has proved to be eco-friendly far more than fossil fuels. Biodiesel is known as a carbon neutral fuel because the carbon present in the exhaust was originally fixed from the atmosphere. These Biodiesel are a mixture of mono-alkyl esters obtained from vegetable oils like soybean oil, *Jatropha* oil, rapeseed oil, palm oil, sunflower oil, corn oil, peanut oil, canola oil and cottonseed oil. The direct usage of vegetable oils as biodiesel is possible by blending it with conventional diesel fuels in a suitable ratio and these ester blends are stable for short term usages but this direct usage of oil is inefficient in long run due to its chemical properties. Hence vegetables oils are processed so as to acquire properties (viscosity and volatility) similar to that of fossil fuels and the processed fuel can be directly used in the diesel engines available. Three processing techniques are mainly used to convert vegetable oils to fuel form (Ma and Hanna, 1999) and they are pyrolysis, micro emulsification and transesterification. These three methods are well distinguished in the Table 5 below.

*Table 5 Method for conversion of vegetable oil to biodiesel*

Methods	Info	Advantages	Disadvantages	reference
<b>Pyrolysis</b>	Through heat the conversion of long chain biomass based saturated substance to biodiesel.	Pretty similar to petroleum derived fuels chemically.	Higher cost due to energy intensiveness	(San José Alonso et al., 2005; Winayanuwattikun et al., 2008)



<b>Micro-emulsification</b>	An equilibrium dispersion of isotropic fluid microstructures with dimensions ranged from 1-150 nm from two immiscible liquids and ionic or non-ionic amphiphiles.	Low viscosity and better combustion pattern.	Low energy contents and low cetane number	(Demirbas, 2007; Sahoo and Das, 2009)
<b>Transesterification</b>	Fats or oil reacts with an alcohol through a catalyst to form esters and glycerols.	Renewable, highly cetane number, lower emission and excellent combustion	By-product disposal	(Demirbas, 2009; Ranganathan et al., 2008)

Among these three methods the most common and popular method is transesterification, which is carried out by mixing mono-alkyl esters and glycerol shown in Figure 19 below. The high viscosity component, glycerol, is removed and hence the product has low viscosity like the fossil fuels.

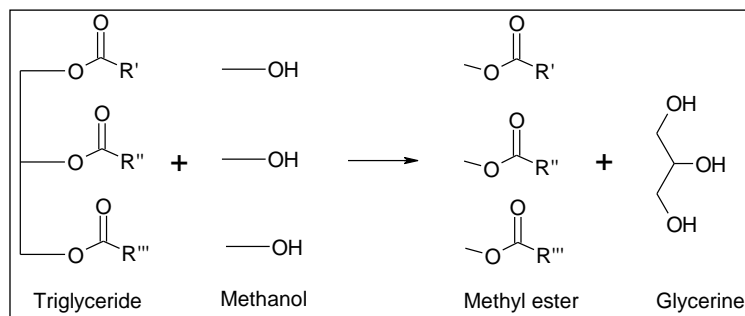

*Figure 19 Biodiesel production sequence*

The transesterification process can be done in a number of ways such as using an alkali catalyst, acid catalyst, biocatalyst, heterogeneous catalyst or using alcohols in their supercritical state. The general reaction is shown below.

*Equation 1 Simplified equation for biodiesel production*

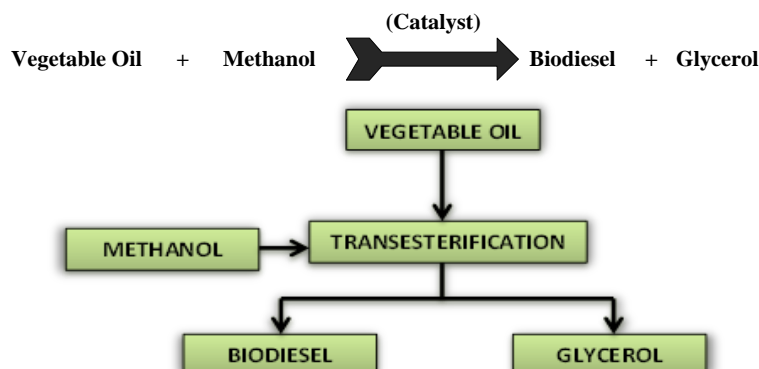

In the alkali process sodium hydroxide (NaOH) or potassium hydroxide (KOH) is used as a catalyst along with methanol or ethanol. Initially, during the process, alcoxy is formed by reaction of the catalyst with alcohol and the alcoxy is then reacted with any vegetable oil to form

biodiesel and glycerol. Glycerol being denser settles at the bottom and biodiesel can be decanted. This process is the most efficient and least corrosive of all the processes and the reaction rate is reasonably high even at a low temperature of 60 °C. The second conventional way of producing biodiesel is using an acid catalyst instead of a base. Any mineral acid can be used to catalyze the process; the most commonly used acids are sulfuric acid and sulfonic acid.

Due to the low cost of raw materials, sodium hydroxide and potassium hydroxide are usually used as alkali a homogeneous catalyst for transesterification on commercial scale. These materials are very economic because the alkali-catalyzed transesterification process is carried out under the environment with low temperature and pressure, and the conversion rate is high with no intermediate steps. The alcohol materials that can be used in the transesterification process include methanol, ethanol, propanol, butanol, and amyl alcohol. Among these alcohols, methanol and ethanol are used most frequently. Methanol is especially used because of its lower cost and its physical and chemical advantages.

Once the transesterification reaction is completed, two major products exist: esters (biodiesel) and glycerol. The glycerol phase is much denser than the biodiesel phase and settles at the bottom of the reaction vessel, allowing it to be separated from the biodiesel phase. Phase separation can be observed within 10 min and can be completed within several hours of settling. The reaction mixture is allowed to settle in the reaction vessel in order to allow the initial separation of biodiesel and glycerol, or the mixture is pumped into a settling vessel. In some cases, a centrifuge may be used to separate the two phases (Gerpen, 2005).

The transesterification process can be carried out even without catalyst but with considerable increase in temperature. Yield is very low at temperatures below 350 °C and therefore higher temperatures were required. However at temperatures greater than 400 °C thermal degradation of esters occurred (Demirbas, 2007). Recently it has been found that alcohols in their supercritical state produce better yield and researchers have experimented this process with methanol in its supercritical state. Of all the methods mentioned above for production of biodiesel, only the alkali process is carried out in an industrial scale. It is cost effective and highly efficient. But problems arise in the downstream operations including separation of catalyst and unreacted methanol from biodiesel.

Both the biodiesel and glycerol are contaminated with an unreacted catalyst, alcohol, and oil during the transesterification step. Soap that may be generated during the process also contaminates the biodiesel and glycerol phase. According to the statements of Gerpen, (2005), typically produced glycerol is about 50% glycerol or less in composition and mainly contains water, salts, unreacted alcohol, and unused catalyst. The unused alkali catalyst is usually neutralized by an acid. In some cases, hydrochloric or sulphuric acids are added into the glycerol phase during the re- neutralization step and produce salts such as sodium chloride or potassium sulphate, the latter can be recovered. After the re-neutralization step, the alcohol in

the glycerol phase can be removed through a vacuum flash process or by other types of evaporators. Usually, the alcohol vapor is condensed back into liquid and reused in the process. However, the alcohol may contain water that should be removed in a distillation column before the alcohol is returned to the process.

Normally, crude biodiesel enters a neutralization step and then passes through an alcohol stripper before the washing step. In some cases, acid is added to crude biodiesel to neutralize any remaining catalyst and to split any soap. Soaps react with the acid to form water soluble salts and free fatty acids. Unreacted alcohol should be removed with distillation equipment before the washing step to prevent excess alcohol from entering the wastewater effluent. The primary purpose of this step is to wash out the remnants of the catalyst, soaps, salts, residual alcohol, and free glycerol from the crude biodiesel. Generally, three main approaches are adapted for purifying biodiesel: water washing, dry washing, and membrane extraction.

Many researchers recognized that one of the main factors affecting the yield of biodiesel is the molar ratio of alcohol to triglyceride. Theoretically, the ratio for transesterification reaction requires 3 mole of alcohol for 1 mole of triglyceride to produce 3 mole of fatty acid ester and 1 mole of glycerol. An excess of alcohol is used in biodiesel production to ensure that the oils or fats completely converted to esters and a higher alcohol triglyceride ratio can result in a greater ester conversion in a shorter time. The yield of biodiesel is increased when the alcohol triglyceride ratio is raised beyond 3 and reaches a maximum. In addition, the molar ratio is associated with the type of catalyst used and the molar ratio of alcohol to triglycerides in most investigations is 6:1, with the use of an alkali catalyst. At the beginning, the reaction is slow due to the mixing and dispersion of alcohol into the oil. After a while, the reaction proceeds very fast. Normally, the yield reaches a maximum at a reaction time of <90 min, and then remains relatively constant with a further increase in the reaction time. Biodiesel production is also influenced by reaction temperature as a higher reaction temperature can decrease the viscosities of oils and result in an increased reaction rate, and a shortened reaction time. The reaction temperature must be less than the boiling point of alcohol in order to ensure that the alcohol will not leak out through vaporization. Depending on the oil used, the optimal temperature ranges from 50 °C to 60 °C. Catalyst concentration can affect the yield of the biodiesel product. As mentioned before, the most commonly used catalyst for the reaction is sodium hydroxide. As the catalyst concentration increases the conversion of triglyceride and the yield of biodiesel increase. This is because an insufficient amount of catalysts result in an incomplete conversion of the triglycerides into the fatty acid esters.

#### **4.2.2 *Jatropha Transesterification process***

A number of researchers have transesterified *Jatropha* oil with methanol and ethanol, using alkaline catalysts such as KOH and NaOH despite their drawbacks (Berchmans et al.,

2013; Chitra et al., 2005; Om Tapanes et al., 2008; Tang et al., 2007). Jatropha transesterification process is presented in detail in the appendixes 15.3.1

### 4.3 CRITICS OF JATROPHA

Production of biodiesel from Jatropha was initially generated enthusiasm among the important producers and manufacturers. However, this sector has grown many criticisms about the economic viability and on social environment. We therefore make an inventory of this sector which is summarized in Table 6 SWOT (Strengths Weaknesses Opportunities Threats).

This is a strategic planning tool used to evaluate the Strengths, Weaknesses, Opportunities, and Threats involved in a project or a business venture (Rutz and Janssen, 2007). A SWOT matrix (Table 6) allows us to know the global over view like its negative-positive impacts or internal-external advantages and disadvantages. The matrix summarizes the viability of biodiesel in order to replace the fossil fuel.

Table 6 SWOT analysis for Jatropha (adapted from Rutz and Janssen, 2007)

	Positive Approach	Negative Approach
Internal Approach	<p><b>Strength</b></p> <ul style="list-style-type: none"> <li>• Grow easily in semi-arid areas</li> <li>• Environmental friendly</li> </ul>	<p><b>Weaknesses</b></p> <ul style="list-style-type: none"> <li>• Variation in returns</li> <li>• Toxic for producers</li> <li>• Competition with food crops</li> </ul>
External Approach	<p><b>Opportunities</b></p> <ul style="list-style-type: none"> <li>• Local development for poor's</li> <li>• Increased demand of biodiesel for aviation</li> <li>• Huge increase in oil price</li> </ul>	<p><b>Threats</b></p> <ul style="list-style-type: none"> <li>• Development of other agro biofuels</li> </ul>

#### 4.3.1 Competition with food product

Growing on arid soils, low fertility, the non-edible Jatropha does not enter into competition with food crops, thus avoiding to fill areas of land originally intended for food products. However it turns out that the performance of Jatropha are much better on more fertile soils. Jatropha is a plant that grows easily on a barren land but produces very little about it. Thus, the culture of this plant tends to grow also on arable land. So this enables Jatropha to enter in competition with food crops and water resources in countries where people lack water and hungry. The mass production of biodiesel from Jatropha led to land grabbing in Africa smallholders on behalf of

major manufacturers. According to Mariann Bassey (coordinator of Food and Agriculture of Environmental Rights Action / Friends of the Earth Nigeria) these practices can also lead to increased food prices (Cozier, 2010). Thus, it appears that the same culture of non-edible plants such as *Jatropha* would be a threat to food security.

#### ***4.3.2 Economic viability for commercial plantation of *Jatropha****

As the new millennium began, soaring oil prices and concerns about the environmental impact of fossil fuel combustion led to a search for new sustainable biodiesel feed stocks. *Jatropha* suddenly became very popular and is touted since then as one of the most promising future major oil crops by developed and developing countries alike. Companies from developed countries recognize *Jatropha* as a new export crop for developing countries to supply western economies with “green fuel” while developing and newly industrializing countries like India see mainly their potential to reduce dependency from costly oil imports. *Jatropha* was considered at a time as the new “green gold”. It seems that this is no longer the case mainly because yields are not as good as expected. The predictive calculations let companies expect a yield of nine tonnes of oil per hectare crop but proved much less lucrative: 1.5 to 7.8 tonnes per hectare, and very random. In addition, the low genetic variability of the shrub makes it very vulnerable to diseases and parasites. But above all, the necessary quantities of water and mineral salts were far more important than what was announced, even when *Jatropha* is performed on good land.

The economic viability of *Jatropha* is widely questioned. Many producers and investors have withdrawn from this sector, which was at the start was in a hurry to invest. For example the British petroleum (BP) has withdrawn from a joint venture with another UK company D1 Oils to exploit *Jatropha*, while the Dutch company BioShape, who had acquired land in Tanzania, went bankrupt in 2010. Paul de Clerck, coordinator of the Economic Justice Friends of the Earth criticized the economic mirage that causes the production of biodiesel from *Jatropha*: “The European Investment companies are advertising for *Jatropha*, promising a guarantee return on investment with cultivation on marginal lands, but these promises are absolutely not realistic”. Many projects have already been abandoned because yields were well below promises, even on good land.

#### ***4.3.3 Impact on the environment and human health***

*Jatropha* plant is basically a toxic plant that protects crops against livestock. However, these toxicity consequences in humans, many farmers have suffered from skin problems, and also in the flora and fauna. In India, cattle are regularly poisoned by *Jatropha*. Cases of fatal poisoning in birds have also been identified. In addition, the shrub is an invasive plant, which is facing a ban situation in Australia and South Africa. Other environmental impact are discussed in the next section.



---

## 5. Conclusion and Research Objectives

---

This chapter rounds up the literature review in life cycle thinking for biofuels and the role of process system engineering for environmental evaluation of these biofuels.

## 5.1 SUMMARY OF PART A

The literature review in part A is summarized here, which managed to be the combination of three main components. We started with the review of sustainability issues and its evaluation through life cycle thinking. Different sustainability issues were discussed in detail with the problem orientation drawn through the LCT with special emphasis on life cycle assessment. This review also explores some broader aspects of bioenergy, i.e. economic and political frameworks and biomass potential, which are presented generation wise in this part. The complete review as a part of this section was accepted for publication in chemical product and process modeling. LCT methodologies are also highlighted in this part along with their concurrence with the present study. Further LCA is reviewed with its historical background and different phase of evolution with ISO norms. It was found that this method, widely acclaimed and developing, can assess the environmental impacts of a product, service or process. At present, it is mainly applied to the environmental assessment of products and very few studies are available for the integration of environmental considerations in the field of processes. The literature review conducted on the LCA process shows that it looks like a very interesting tool for the design and optimization of these, and highlights the interest of the couple with process engineering tools to allow the integration of environmental considerations in addition to technical and economic considerations in their implementation and optimization, whether for a global process or unit operation. Then in the 3<sup>rd</sup> part we discussed the techniques related to bioenergy production along with its types at the present stage. We conclude this review of biofuels with a critical overview i.e. competition with food crops, economic viability and different environmental hazards.

## 5.2 RESEARCH QUESTIONS INCURRED

The concept of renewable is permanently linked up with environmental considerations. Indeed, consider new methods to reduce the environmental impacts of human activities through the use of renewable resources rather than fossil appears to be a way forward. The research focused on coupling of PSE domain with the environmental analysis of agricultural and chemical activities and abatement strategies for a biodiesel production from *Jatropha* with the help of computer aided tools and models. The main objective of this Ph.D. work is to define an innovative frame based on LCA and PSE integration for a product, process and system perspectives. That would lead to an improved eco-analysis, eco-design and eco-decision of processes and resulted products for researchers and engineers. Compliant to this approach we develop a research prototype software tool.

In accordance to these objectives this dissertation contributes to the knowledge on the potential sustainability of *Jatropha* biodiesel in the first place. At the start of the research it was hypnotized that:



- Biodiesel production and use reduces non-renewable energy use and greenhouse gas emission compared to the fossil diesel reference system;
- Coupling of this biodiesel environmental evaluation with PSE dedicated tools from CAPE<sup>2</sup> for further development of the present system;

For this purpose we evaluate biodiesel for environmental analysis with the help of field data, background data from Ecoinvent database and Impact 2002+ and CML 2 impact methodologies. For result quantification and evaluation, SimaPro and Excel are used as handout tools. Make a quantitative and qualitative overview of the knowledge on the Jatropha biodiesel production system available in scientific literature and public reports in order to create order in the chaos and to identify the main knowledge gaps. A generic LCA assessing the potential impact of the model Jatropha biodiesel production system, the 'average' system currently applied all over the world.

This research work helps to answer the following key questions:

- ✓ What are the concepts and methods of engineering for industrial systems sustainability?
- ✓ How to improve the current methodology of LCA for environmental evaluation?
- ✓ What are the tools, methods and concepts that underlie the integration of environmental consideration in PSE?
- ✓ What are the prospects for coupling LCA method and PSE and the benefits of integrated framework??

---

<sup>2</sup> CAPE (Computer Aided Process Engineering) is a part of PSE domain which deal with different tools for simulation and modeling of process design. In this research work we will use the term PSE to encircle these dedicated tools from CAPE.



---

## PART B

---

# **B. LIFE CYCLE ASSESSMENT OF JATROPHA BIODIESEL PRODUCTION SYSTEM**



---

This part presents a case study of Jatropha LCA for a biodiesel production system from experimental site of Mali, West Africa that is being used for reclaiming waste land and for producing biodiesel. Our analysis goes beyond assessing energy outputs and greenhouse gas balances and includes assessing other environmental impacts, particularly with respect to acidification, eutrophication and toxicity. This analysis provide an opening to Part C, at the same time it provides firsthand data and background for further simulation of its unitary processes (Chapter 10) and at the end its coupling within the present LCA which we termed as simulated LCA tool (Chapter 11). Further we also discussed the methodology used for this LCA with a brief overview of LCA tools. We also highlighted the limits of system and evaluate the uncertainty issue regarding data quality. Further we elaborate our results for sustainable evaluation of Jatropha LCA.

This part is subjected to (Gillani et al., 2012).and (Gillani et al., 2011b)



---

## 6. Methodology of Life Cycle Assessment

---

LCA is an environmental assessment method. This method takes into account all environmental effects of a product, including exploration of the resources, transport, manufacturing, emissions, and disposal (cradle to grave). The environmental effects are clustered into impact categories, in which the collected data are correlated with each other. LCA is the most developed assessment tool for whole product manufacturing systems. LCA provides background information for discussion within the public expert for further ecological needs and potential improvements in processes. Due to the flexibility of this method it can be applied to all types of production, i.e. agriculture and forestry, and industry. In this chapter we discussed in detail the LCA methodology used for our research work.

## 6.1 GENERAL PRESENTATION

Life Cycle Assessment (LCA) is a method of evaluating environmental effects of a product throughout its life cycle or lifetime, which is known as a 'from cradle to grave' analysis (Arvanitoyannis, 2008) (Figure 20). Life cycle thinking resulted from the need to embrace the wider perspective of a product's whole system and evaluate it throughout all stages of its life cycle. Life cycle assessment comprises either a conceptual framework of a set of practical tools to analyse all the activities that go into making, transporting, using and disposing of a product. The main advantage of LCA is in supporting decision making with scientific data and competence (Berkhout and Howes, 1997). The application of the process and associated waste minimization practices by management, design and manufacturing can also lead to environmentally better products as well as less expensive and marketing competitive one (Azapagic and Clift, 1999a).

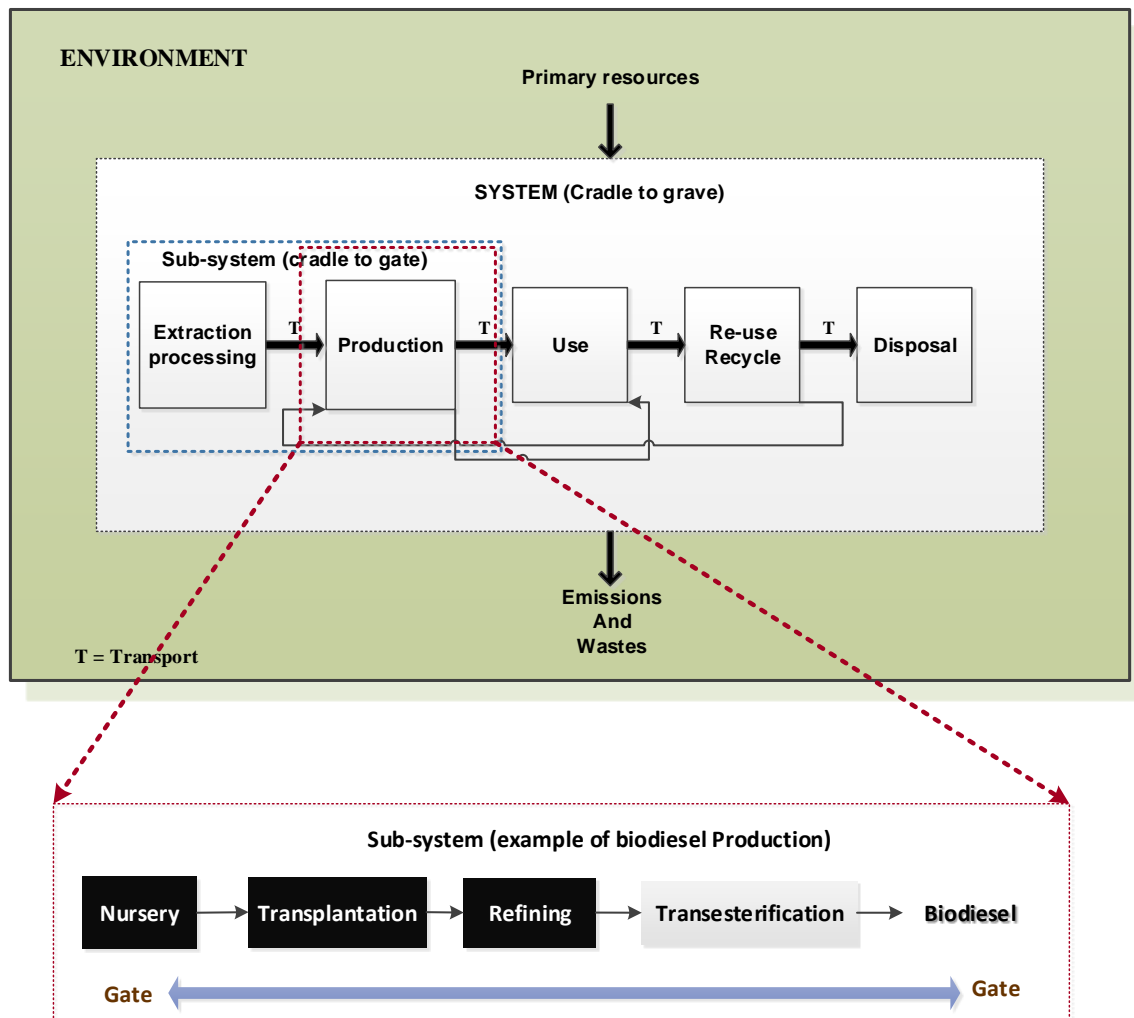

Figure 20 A product life cycle from cradle to grave

In a more detailed manner, it is considered that LCA has the following phases according to ISO norms 14040-14044 (ISO 2006) (Figure 21):



- i) definition of goal and scope
- ii) inventory analysis
- iii) impact assessment
- iv) result and interpretation

The classification assigns the emissions from inventory to these impact categories according to the substances ability to contribute to different environmental problems. According to the ISO standard on LCA, selection of impact categories, classification, and characterization are mandatory steps in LCIA, while normalization and weighting are optional (ISO, 2006). Impact categories regarding resource depletion has been discussed quit frequently and there are wide varieties of methods available consequently for characterizing contributions to this category (Pennington and Rydberg, 2005). The life cycle inventories illustrate material and energy flows that lie within the system boundaries. On the other hand the impact assessment access and characterize the environmental effects that are gained by the combination of risk assessment and data obtained from inventory. Several life cycle impact assessment methods exist comprising different methodologies. This often leads us to different results, thus making it difficult for the LCA to determine which results yield the best. Therefore it is important to understand the differences between models in order to clarify portrayal of the impacts of a life cycle inventory.

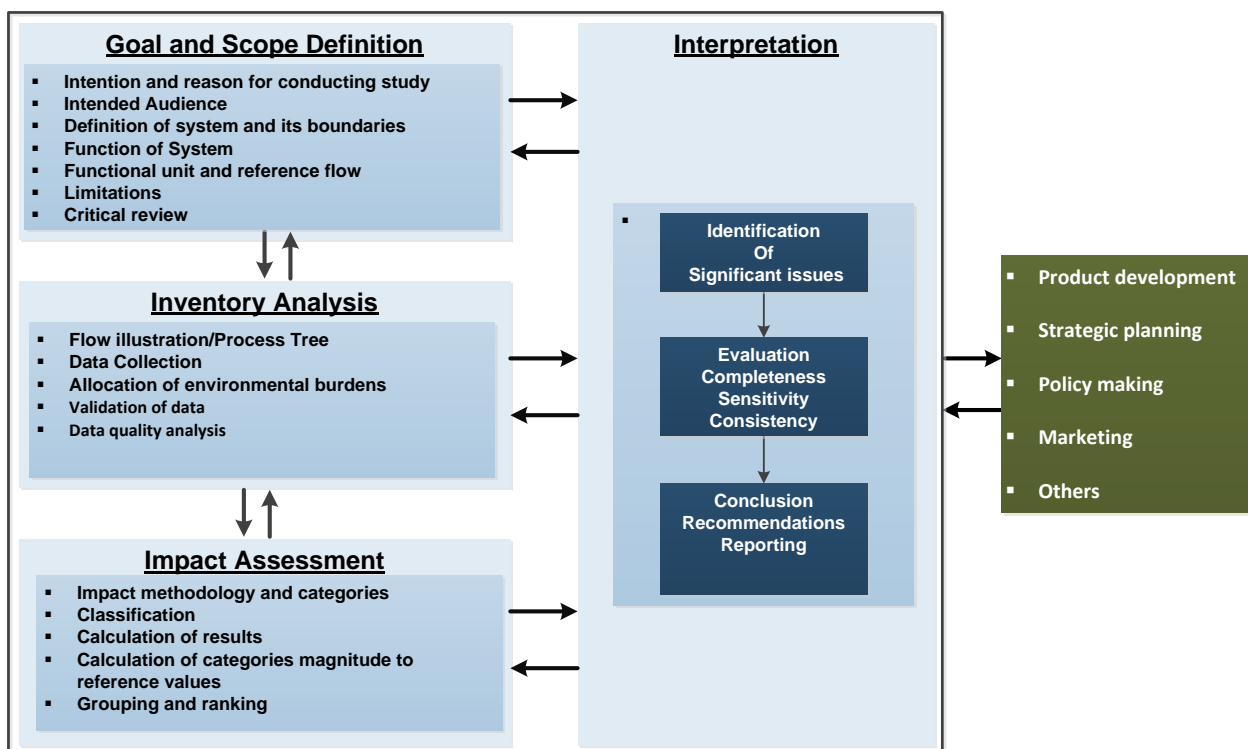

Figure 21 LCA methodology framework with respect to ISO 14044 norms

### 6.1.1 Goal and Scope Definition

This step defines the reasons for the LCA study and the intended use of the results. For LCA studies in the agricultural sector this could be for instance to investigate the environmental impacts of different intensities in crop production or to analyze the advantages and disadvantages of intensive or extensive arable farming systems. According to ISO 14040 standards the goal of LCA must state the application and reason of carrying out LCA study. For LCA studies in the agricultural sector this could be for instance to investigate the environmental impacts of different intensities in crop production. The scope definition helps us to mention the functions and boundaries of a system for which the LCA been done. Furthermore, this step describes the system under investigation, its functions, and boundaries. The system boundaries largely depend on the goal of the study and the functional unit (FU) is dependent on the goal of the study. In the goal definition and scoping component, the purpose of the study and its scope are defined in relation to how the results are to be used. The functional unit is established in this step, with the necessary data and information needed for the inventory and impact assessment also identified (Consoli, 1993).

#### ➤ Functional Unit

According to the definition of ISO 14040 the functional unit is a measure of the performance of the functional outputs of the product system (Arvanitoyannis, 2008). All material and energy flows and all effects resulting from these flows are related to the functional unit. This makes the functional unit a base for all comparisons between sensitivity analysis and different objects under investigation within the same functional unit. Relating all data to one functional unit makes the results of different studies comparable. The ISO 14040 standards demand that functional units are clearly defined, measurable, and relevant to input and output processes (Arvanitoyannis, 2008; Jolliet et al., 2004).

#### ➤ System boundary

The definition of system boundaries illustrates which modules have to be part of the LCA in a study. Multiple factors, such as time, money, and determinability of data influence the system boundaries. Ideally the system under investigation is defined in such a way that input and output flows are elementary flows at the point of the system boundaries. The module which shall be included and which data quality should be obtained for each module of the LCA is determined. Equally, each output flow has to be determined. The system boundaries have to be designed including all processes, depending on the number and kind of products. This can lead to large life cycle inventories, which cannot be dealt with.

### 6.1.2 Inventory Analysis phase

The inventory analysis compiles all resources that are needed for and all emissions that are released by the specific system under investigation and relates them to the defined

functional unit (ISO, 2006). The inventory analysis step of an LCA quantifies the inputs and outputs (products and releases to air, water and land) for all processing steps included in the system boundary. Many life cycle studies have stopped at the inventory stage, often basing conclusions and recommendations on how the inventory interventions can be minimized. However, the major drawback with this approach is that information on whether some categories in the inventory analysis are more hazardous than other phases, as this phase involves most time consuming tasks so the risk factor is high (Taylor et al., 1994). This phase is crucial as it should guarantee the availability and quality of raw data. The data collection is a strategic point in order to go through a valid analysis and then to result in high-quality decisions.

The emissions and extractions data includes the amount of resources extracted and the pollutants emitted during its life cycle through different referenced database systems. There are specific databases to the LCA methodology such as Ecoinvent, European Life Cycle Database and U.S. life cycle inventory database that identify emission factors and extraction related to different input and output. These give the amount of each substance emitted or extracted per unit of input used. For example, the output from unitary process of “extraction” (termed as  $X_1$ ) is 3kg of raw material per functional unit (FU). This activity is associated with the emissions such as 0.2 kg of  $CO_2$  ( $bc_{CO_2}$ ) and 0.1 kg of  $CH_4$  for 1 kg of raw material extracted. So the calculation of this inventory will be 0.6 kg/t<sub>FU</sub> for  $CO_2$  and 0.3 kg/t<sub>FU</sub> through equation 1 and 2:

*Equation 1 Inventory for each unit per FU*

$$B(CO_2) = bc_{CO_2} \times X_1$$

So therefore the total Inventory analysis we have is:

*Equation 2 Total Inventory*

$$B_j = \sum_{i=1}^I bc_{j,i} X_i$$

Where  $B_j$  is total inventory obtained through the multiplication of burden or emission  $bc$  per vector of production  $X$ .

### 6.1.3 Impact Assessment phase

The purpose of the Life Cycle Impact Assessment (LCIA) is to provide additional information to help and assess the results from the Inventory Analysis so as to better understand their environmental significance (ISO, 2006). Today, there is acceptance in the LCA community that the protection areas of Life cycle assessment are human health, natural environment, natural resources, and to some extent man-made environment (Guinée et al., 1993). The impact assessment phase of an LCA is defined as “a quantitative and/or qualitative process to identify, characterize and assess the potential impacts of the environmental

interventions identified in the inventory analysis". According to the SETAC, impact assessment consists of three distinct steps: classification, characterization (including normalization) and valuation (Consoli, 1993). This approach to impact assessment has gained the widest acceptance (Miettinen and Hämäläinen, 1997). In the classification step, the resources used and wastes generated are grouped into impact categories based on anticipated effects on the environment. These impact categories might include environmental problems such as resource depletion, global warming, acidification and photochemical oxidant formation as shown in the Figure 22. The potential contribution to each environmental impact category is then quantified in the characterization step, which takes into account both the magnitude and potency of the inventory categories (Taylor et al., 1994).

Life cycle impact assessment (LCIA) as part of an overall LCA can be used to:

- identify product system improvement opportunities and assist the prioritization of them
- characterize or benchmark a product system and its unit processes over time
- make relative comparisons among product systems based on selected category indicators
- Indicate environmental issues for which other techniques can provide complementary environmental data and information useful to decision-makers

Thus LCIA methods aim to connect, as far as possible each life cycle inventory (LCI) result to the corresponding environmental impacts. LCI results are classified into impact categories, each with a category indicator. The category indicator can be located at any point between the LCI results and the damage category (where the environmental effect occurs) in this chain. Within this framework, the LCIA methods are generally divided into two groups:

- a) Problem oriented approach i.e. CML 2 (Guinée, 2002)
- b) Damage oriented approach such as Eco-indicator 99 (Goedkoop and Spriensma, 2001) or IMPACT 2002+ (Jolliet et al., 2004).

The methods for impacts analysis have been widely described in the literature (Bare, 2002; Goedkoop and Spriensma, 2001; Goedkoop et al., 2009; Guinée, 2002; Hauschild and Alting, 1997; Jolliet et al., 2003). In 2010, the European Commission has published a guide that references these methods and analyzes the strengths of each of them with respect to environmental considered (European Commission, 2010). These methods are the result of several years of work and each has their specificities with the desire and objectives of not only to provide the characterization but to induce the least amount of uncertainty, factor of both intermediate characterization and also damage factor characterization. In the problem oriented methods, environmental burdens are aggregated according to their relative contribution to the environmental impact that they might cause. Damage oriented on the other hand model the endpoint damage caused by environmental burdens to the protection area which includes human health, ecosystem, resources and climate changes (Udo de Haes and Lindeijer, 2002).

Emissions and extractions obtained in the inventory are assigned to these categories. This step is called “classification” (Figure 22). The intermediate characterization method (also called midpoint assessment) quantifies all the impact factors contributed by each inventory flow resulted from emission and extraction for each impact category. Specifically, the masses of substances generated and extracted listed in the inventory of emissions and extractions are multiplied by these characterization factors and summed up in each of the intermediate categories, thus providing the intermediate impact score, expressed in a common unit (Equation 3).

Equation 3 Midpoint calculation for impact score ( $SI$ )

$$SI_i = \sum_{s=1}^S (FI_{s,i} \times M_s)$$

Where  $SI$  is the impact score for respective midpoint category;  $FI$  represents midpoint characterization factor for substance  $s$  and impact  $I$ ;  $M$  shows the mass for emission or extraction for the substance  $s$ .

The final stage after midpoint impact is endpoint or damage assessment. This step allows the combination of all the impacts from the midpoint impacts to further larger damage categories but in respective consideration that each intermediate impact category has a greater or lesser responsibility in contributing to the damage assessed. Thus, to pass through midpoint characterization to a damage evaluation, and to get a score of damage characterization, it is to multiply midpoint impacts of the respective substance by its damage characterization factor. This is calculated as in Equation 4:

Equation 4 Calculation of damage assessment ( $SD$ )

$$SD_d = \sum_{i=1}^I (FD_{i,d} \times SI_i)$$

Where  $SD$  a score of damage;  $FD$  is endpoint characterization factor of a damage category for data  $d$  and for midpoint category of  $i$ ; and  $SI$  is the relative midpoint score.

The further optional steps are normalization grouping and weighting which helps to extend LCA studies for an activity contributed to regional or global environmental impacts. Figure 22 shows midpoint categories and damage categories (endpoint) from the LCI results.

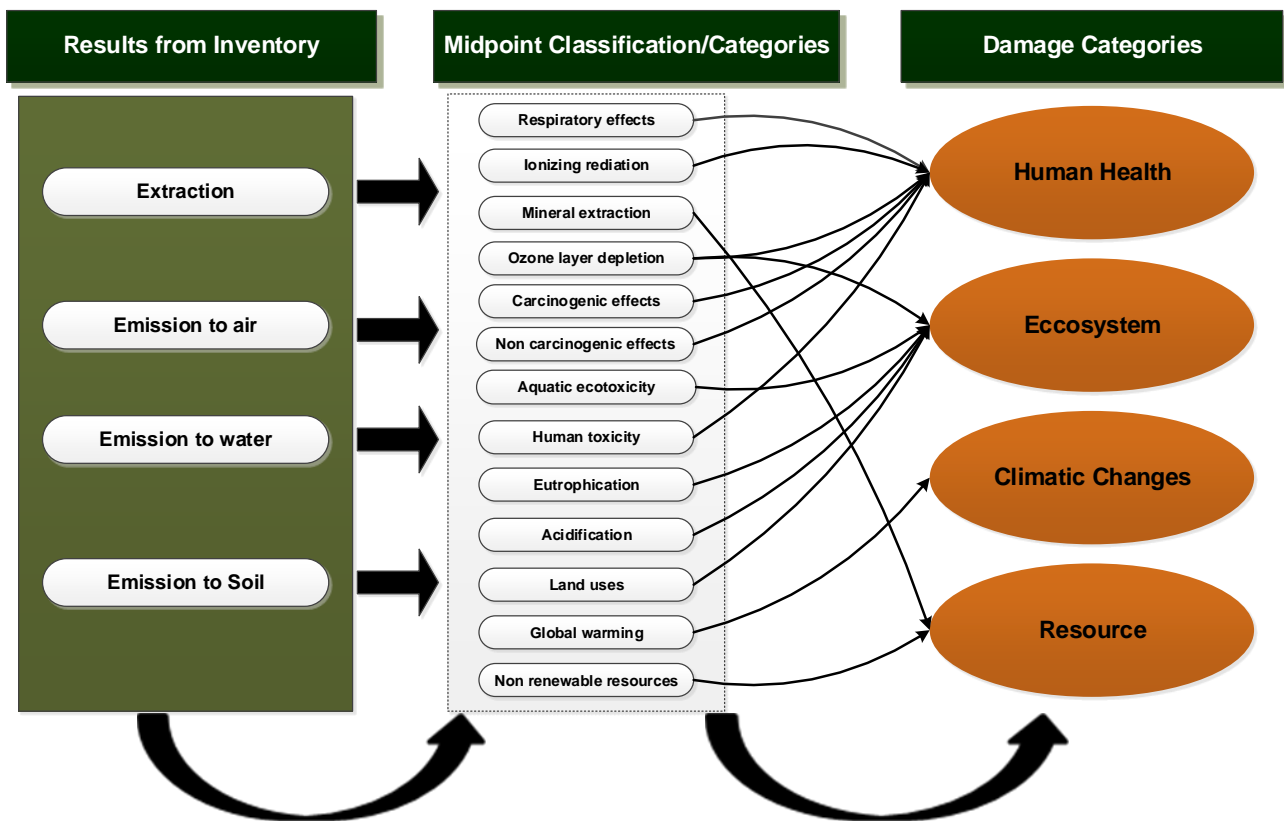

Figure 22 General phases for impact assessment in LCA (adapted from Jolliet et al., 2010)

#### 6.1.4 Interpretation phase

The purpose of an LCA is to draw conclusions that can support a decision or can provide a readily understandable result of an LCA. This assessment may include both quantitative and qualitative measures of improvement, such as changes in product, process and activity design; raw material use, industrial processing, consumer use and waste management.

Interpretation is the phase of the LCA where the results of the other phases are interpreted according to the goal of the study using sensitivity and uncertainty analysis. The outcome of the interpretation may be a conclusion serving as a recommendation to the decision makers, who normally consider the environmental and resource impacts together with other decision criteria (like economic and social aspects) in a sustainability context. ISO and other sources define an interpretation component, instead of an improvement assessment, as being the final component of the impact assessment (Heijungs et al., 2010; Rebitzer et al., 2004). Furthermore, Azapagic and Clift, (1999b) writes that using the results of an LCA is now often referred to as interpretation, with the recognition that explicit trade-offs between impacts categories are required as part of the decision-making process.

## 6.2 DATABASE FOR LCA

Life cycle inventory requires a lot of data to be setup for further calculation and this setting up is one of the most exhaustive and time consuming phase of LCA. In order to facilitate the

inventory analysis and to avoid duplication in data compilation, many databases have therefore been developed in the past few years. These include public national or regional databases, industry databases, and consultants' databases that are often linked to different LCA software. National or regional databases, which evolved from publicly funded projects, provide inventory data on a variety of products and basic services that are needed in every LCA, such as raw materials, electricity generation, transport processes, and waste services as well as sometimes complex products.

The United Nations Environment Program (UNEP) and the European Commission, through their portal directory of LCA resources (European Commission, 2012, the United Nations Environment Program, 2012) update and make available a certain number of information for LCA data bases i.e. Ecoinvent v2.2 database, which is used for this study in particular. Indeed, Ecoinvent database proves to be one of the most reliable and complete database for LCA applications at the European level, (Jolliet et al., 2010). Other national and international public databases that have been released in the past are the Swedish SPINE@CPM database (Carlson et al., 1995), the German PROBAS database (UBA, 2007), the Japanese JEMAI database (Narita et al., 2004), the US NREL database (NREL, 2004), the Australian LCI database (Tharumarajah and Grant, 2006) and the European Reference Life Cycle Database (ELCD) (European Commission, 2007).

Further databases are currently under development all over the world, for example, in Brazil, Canada, China, Germany, Malaysia, Thailand, and other countries. Complementary to public inventory databases, and often a major source of their data, numerous international business associations worldwide have created their own inventory datasets as a proactive effort to support the demand for first-hand industry data. Some databases, such as the Ecoinvent and the US NREL databases, provide data modules used to build inventories on a disaggregated unit-process level (e.g., for a chemical processing facility with multiple products such as a refinery). This means that the inputs and outputs are recorded for each unitary process, in addition to aggregated data sets (cradle-to-gate). In contrast, many other databases (such as databases provided by industry associations) supply inventory data. This data is already-aggregated (such as cradle-to-gate sub-systems), which specify the elementary flows (i.e. resource expenditures, emissions, and wastes) for all processes involved.

The majority of database systems is based on average data representing average production and supply conditions for goods and services, and thus employs the attributional modeling approach. Quality and consistency are key issues related to inventory data. While within specific databases, these are ensured to some extent, across databases there can exist significant differences. This includes data documentation (different data formats), modeling approaches (consideration of capital goods, allocation procedures), and nomenclature of flows

and environmental exchanges denoted in the inventories. Bridging these differences to ensure the efficient exchange of data is one of the challenges in the field of LCA.

### **6.3 REVIEW OF LCA TOOLS**

Life cycle assessment systematically considers and quantifies the consumption of resources and the environmental impacts associated with a product and its associated process. By considering the entire life cycle and the associated environmental burdens, LCA identifies opportunities to improve environmental performance. In order to support engineering activities, LCA specific software have been developed since 90's. Established tools, often coming from university research activities, are provided by small editors or organizations. Three of these leading market LCA software are discussed hereby. Except these tools off the shelves, it is worth noting that some universities and industrial organizations have developed their own inner tool (in general based on Microsoft Excel application) and data base.

Gabi life cycle assessment tool (PE International, 2007) has been developed by more than 60 developers which provide over 4000 LCI profile for professionals and engineers over the years. All these profiles are ISO 14044, 14064 and 14025 standards compiled. In addition Ecoinvent database has been integrated into this tool which provides more access to unit processes as well as to other inventories to cover multiple industrial areas.

SimaPro (PRé Consultant, 1990) collect, analyze and monitor the environmental performance of products and services (Goedkoop et al., 2008). This tool includes the database in compliance to the ISO 14040 standards i.e. Ecoinvent, ETH-ESU 96, BUWAL 250, Dutch Input Output database, US Input Output database, Danish Input Output database, LCA food, Industry data, IDEMAT 2001, Franklin US LCI database and Dutch Concrete database. Umberto is another powerful tool used by many research groups, industries, organizations and IT specialists. It has been used for modeling and also to calculate and visualize material and energy flow systems. It is used to analyze production process systems, either in a manufacturing site, throughout a company, or, along a product life cycle. Results can be assessed using economic and environmental performance indicators. Costs for materials and processes can be entered in the model to support managerial decision making. Umberto addresses companies with cost intensive production that wish to optimize their processes and improve their competitiveness. Umberto also serves as a flexible and versatile tool for research institutions and consultancies, e.g. for material flow analysis studies or for life cycle assessment studies of products.

In our current research project, we are using SimaPro 7. However we hope in near future to have access to Umberto and GaBi tools in order to gain experience on current tools and to support our own software prototype development.



---

## 7. LCA of Jatropha (A West African case study)

---

This chapter is related to the Environmental impact analysis of Jatropha production system from the experimental site of Teriya Bugu in Mali. The main aim is to evaluate different impacts using generic LCA approach with the help of MS Excel and SimaPro LCA software. The LCA allows comparing the environment loads between different products, process or systems as well as different steps of a same product life cycle. This section provides a background for further integration and to find out the most important unitary process in the whole production system for its further integration and coupling with PSE.

## 7.1 GENERAL PRESENTATION

Potential of *Jatropha* feedstock as a significant biofuel production plant has become very prominent in these recent years with reference to many studies examine environmental and social impacts. Another research has been conducted an LCA to evaluate the net energy gain (NEG) and net energy ratio (NER) of biodiesel produced from *Jatropha* cultivated in Thailand (Prueksakorn and Gheewala, 2008). From 24 research sites, their study calculated an NEG of 4.720 GJ/ha and NER of 6.03 for *Jatropha* biodiesel plus co-products. This was not a comparative study to fossil fuel hence did not include the evaluation of GHG emissions. Achten et al., (2008) have published literature review of available studies regarding *Jatropha* biodiesel production and use. Their study provides an overview of the published data on *Jatropha* biodiesel production processes from cultivation and oil extraction to biodiesel conversion and use. Based on the literature reviewed, the author concludes that the energy balance for *Jatropha* biodiesel is having a positive balance with the dependence on co-product use and on fertilization and irrigation requirements. They confirm the reduction in GHG emissions by substituting biodiesel for conventional diesel while identifying irrigation, fertilization and transesterification as the processes with the greatest influence on net GHG emissions. Further their findings determine the reduction of global warming potential by more than 70% to that of fossil fuels.

Reinhardt et al., (2008) provide an Indian based comparison of *Jatropha* with conventional diesel by examining their advantages and disadvantages through LCA screening. The study evaluated the environmental impact categories of consumption of energy resources, greenhouse gas (GHG) emissions, acidification, eutrophication, summer smog formation potential, and nitrous oxide ozone depletion potential. As a functional unit, the authors selected the use of *Jatropha* fruit harvested from one hectare of land in one year (i.e., land use efficiency). The screening LCA evaluated biodiesel use to replace diesel in passenger cars and concluded that *Jatropha* biodiesel generally shows an energy balance savings of about 50% (8 GJ of primary energy per hectare year) and also has a small greenhouse gas emission advantage of about 10% (approximately 100 kg CO<sub>2</sub> eq per hectare year). The study also determined that *Jatropha* cultivation and processing made the greatest contribution to net GHG emissions. However neither of these studies has paired reviewed the impacts using different impact assessment methodologies.

In the present study, we provide an “attributional” LCA using Impact 2002+ methodology. We investigated the biodiesel production from an experimental site of *Jatropha curcas* in western Africa (Mali) and thus presented a more developed model based on existing biodiesel production scheme from the previous study on LCA of *Jatropha* system performed at the Agro-industrial laboratory by Ndong et al., (2009). These developments in the present LCA *Jatropha* project are discussed in the coming sections. For this purpose all the inputs and their values

have been obtained and updated from the mentioned experimental site of Jatropha in Mali. The aim is to provide a general and profound insight in the environmental performance of the production and use of Jatropha biofuel. The goal is to broaden the available information on the system's performance by assessing environmental impacts, to provide benchmark values of these impacts and identify options to improve the performance of current system. In the next section we discuss materials and methods followed by results and discussions. We sum up our present evaluation of Jatropha biodiesel production and its environmental analysis with some concluding remarks at the end.

## 7.2 GOAL AND SCOPE DEFINITION

### 7.2.1 Goal

The process of conducting an LCA as well as its outcomes is largely determined by the goal and scope of a study. In this study the goal is to identify the hot spots in the production process of biofuel and to use the results for further development of how the environmental impacts can be reduced.

The main objective here is, to evaluate all important activities and processes took place during the life span of a Jatropha. Also there is a systematic comparison presented for different impacts categories in between the unitary processes of Jatropha life cycle using Impact 2002+. The results from this study enable us to understand the difference occurred by using different impact methodologies and can be helpful for further improvement in Jatropha biodiesel production.

LCA approach was carried out in accordance to the International Standard Organization guidelines (ISO 14040-44) (see chapter 6). The main calculation for inventory and impact assessment has been carried out through Excel while Ecoinvent database V2.1 is used for inventory analysis regarding emissions and extraction with the help of SimaPro V7.1 LCA software. At the same time this whole data was implemented in SimaPro for results comparison and validation. This comparison is illustrated in the last section of this part.

### 7.2.2 Functional unit

The functional unit is a measure of the performance of the functional outputs of the product system. The ISO 14040 standards demand that functional units are clearly defined, measurable, and relevant to input and output processes (Arvanitoyannis, 2008; Jolliet et al., 2004). So for Jatropha LCA the functional unit is set to be 1 MJ release to an engine fueled by Jatropha biodiesel. There is also a reference flow which initiate and inventory to be made for system inputs and outputs. Here it is the quantity (in kg) of Jatropha seed required to fulfill the functional unit. There is always a limit for each system which includes all the processes in the system for its full functioning (Jolliet et al., 2004). In full LCA studies, the system boundary is

drawn to encompass all the stages in life cycle i.e. “Cradle to Grave”. The system in this study does not include the final combustion of biodiesel in the engine. So we developed a generic LCA for a biodiesel production from *Jatropha curcas*.

### 7.2.3 *Process tree, boundaries and hypothesis*

Soil was used for an estimated study of 30 year in experimental site of Mali. The system extends the culture of *Jatropha* production to biodiesel production, for a life cycle of 30 years. Crop fields are located in Mali and processing took place in Le Havre, France. Our system includes the steps of:

- Cultivation of *Jatropha* plants for one year;
- Planting in the fields;
- Culture in the second year;
- Culture in the third year;
- Culture in years 4-30, where the whole operating conditions are considered to be the same for all these years;
- Transport of oil from field to refinery units and further for transesterification. Oil is transported by truck for 32 km to the field station Teriya Bugu, for 564 km from the station and transported by boat during 6528 km of Mali to Havre.
- Refining;
- Transesterification for biodiesel production

However, the following steps are not taken into account:

- Harvesting of seeds;
- Transport and storage of biodiesel consumption points.

On the other hand, it should be noted as an important point, that only inputs are considered in our analysis of life cycle. Thus, the by-products and emissions related to the operating units and installations are not taken into account. Figure 23 shows the definition of the system studied.

For a generic LCA data were transferred into Excel sheet by creating building blocks in which each block represent a unitary process. Each unitary process has its own inputs and output stream which were defined one by one (Figure 23).

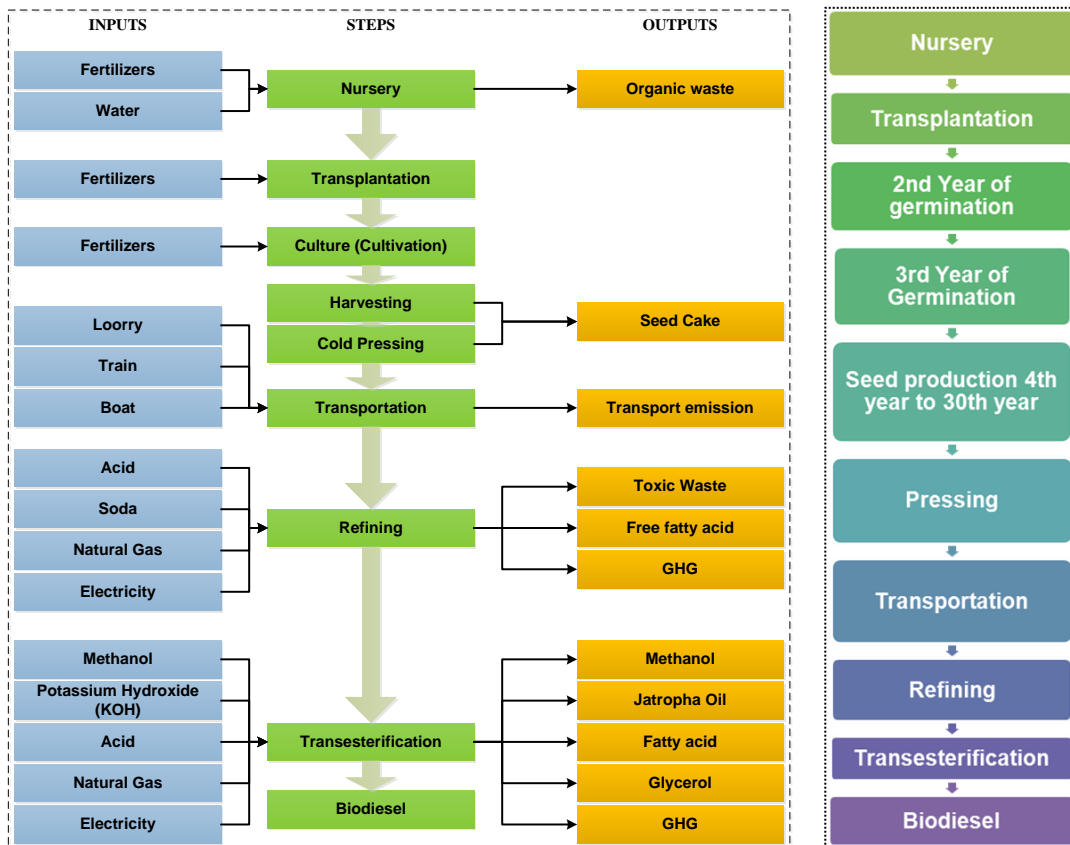

Figure 23 Process tree for *Jatropha* biodiesel production system

Defining each unitary process means one has to define the inputs and outputs of the material energy or process either obtained from collected data or background resources like emissions and extraction from Ecoinvent in SimaPro LCA software. So data were treated in Excel with the help of those inter related blocks in the second part of Figure 23 and there impacts were calculated by using the well-established Impact 2002+ methodology. This enabled us to know the impacts from each unitary process and also the total impacts at the end of our process tree.

### 7.3 LIFE CYCLE INVENTORY

Inventory analysis involves the collection of burdens data necessary to meet the goals of the study. This quantifies the inputs (Mass and Energy) and outputs (products and releases to air, water and land) for all processing steps included in the system boundary. This phase is crucial as it should guarantee the availability and quality of raw data.

#### 7.3.1 Cultivation of *Jatropha* and its management

The cultivation of *Jatropha* was considered to be the first stage of biodiesel production. Resources from experimental research site of Mali West Africa were used to obtain all the valid information regarding cultivation of *Jatropha*. As already mentioned *Jatropha* is a wild plant with wide phenotypic variation, reliable field data is needed to set input levels (Achten et al., 2010a).

Seedling and vegetative propagation through branch cutting are the ways to reproduce *Jatropha* plants. Some suggest the use of seedlings from nurseries seems to enhance cultivation's success as nurseries provide necessary control of environmental factors and allow production of healthy seedlings (Kaushik et al., 2007). In nurseries fertilizers along with pesticides are used in order to get healthy and well established plants. Large scale cultivation of *Jatropha* requires irrigation both in nurseries and in different stages of plant production. *Jatropha* has been tested at different level of irrigation in several studies and in our case we observed the amount of 0.2 - 0.5L of water required by per plant per day (Ndong et al., 2009). *Jatropha* has low moisture requirements but irrigation can bloom the yield. Different quantities of fertilizer N-P-K are applicable in different phase of *Jatropha* plant establishment. The caretaker should monitor the seedling's quality to keep uniformity at best available quality amid the plantation. The use of good available seeds is preferable in order to gain high yield (Gour, 2006). Moreover, this also helps in increased oil content which may be the most important traits in the case of *Jatropha* as an energy crop (Mishra, 2009).

Trimming is done almost first year onwards in order to shape the plant for enhanced branch formation. Additional operations include weeding and hoeing of the plants basin, especially during the establishment period has to be carried out (Kumar and Sharma, 2008). This plant was thought to be toxic enough to overcome the issue of parasitism but this has been proved wrong since there are some species that find nutrients in *Jatropha*. Many researchers have observed pests and diseases of several types associated with *Jatropha* plant and seeds like powdery mildew, flea beetles and millipedes etc. Till now no widely spread diseases have yet been registered (Shanker et al., 2006) but this is going to be changed with commercial plantations and emergence (Gour, 2006).

A *Jatropha* plant takes approximately three years to start yielding. However, some authors state that plants rose from seeds take up to 4 years to yield seeds (Sunder, 2006). It was assumed in general that stable yields start at 4th year onwards of cultivation (Kaushik et al., 2007). A stable figure for plantation yield is missing in the literature. This is due to the lack of systematic analysis but data in this regard ranges from 2 to 7 tonnes/ha/yr of dry seed by many authors (Achten et al., 2008). From our experimental site we had an estimated requirement of 1500 plant per hectare. Out of which about 10% losses were observed due to transplantation. So at the end we have achieved an average of 1250 plants per hectare as an established number to present on the field. In harvesting stage, mature seeds could be distinguished by the dark brown and yellow color. Manual collection is followed by drying of fruits. This drying can be done naturally or mechanically and next drying stage there is seed removal. On average 4t per hectare of grains were collected from these plants from 4th year onwards. This is about 38% of oil on mass basis from those grains.

### 7.3.2 Production of Biodiesel

For quality yield postharvest management is very important which includes different aspects like seed grading and storage and pruning (Gour, 2006). The seeds are transported to the destinations where the oil extraction could be done. Oil extraction is usually carried out through cold pressing with the help of electric screw pressers. Crude *Jatropha* oil requires refining before the introduction of transesterification, depending on seed quality.

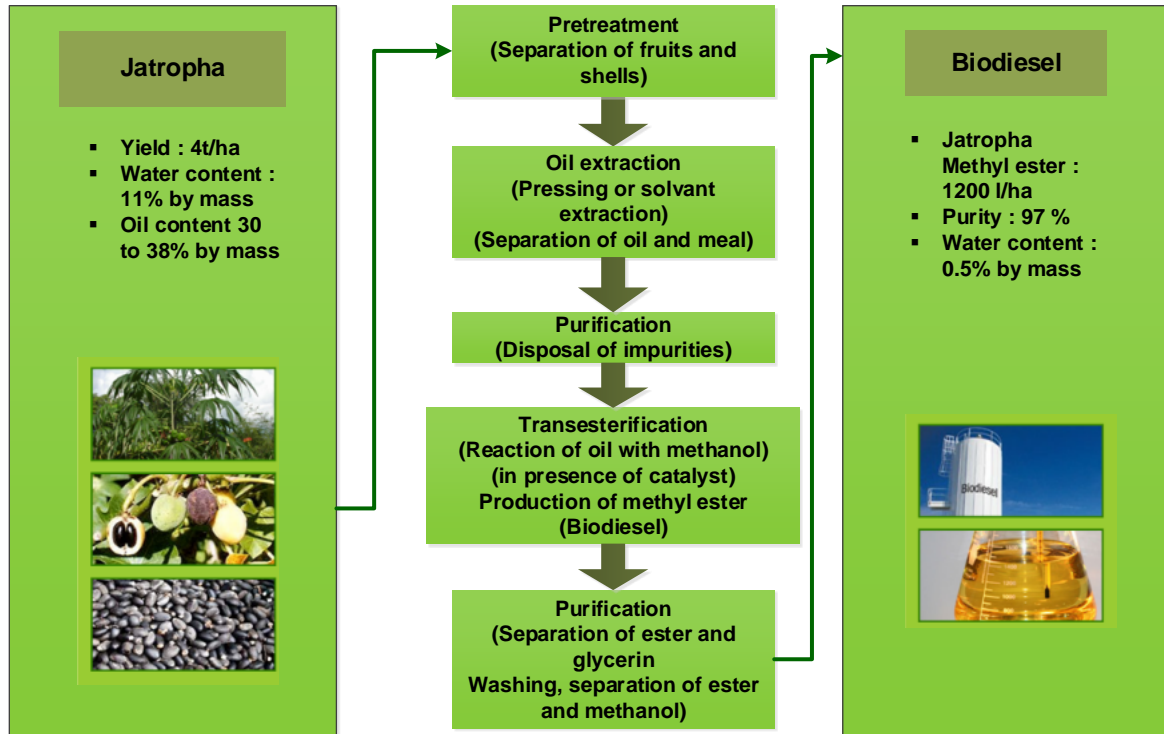

Figure 24 *Jatropha* production on life cycle approach

Through transesterification oil is being converted into the *Jatropha* methyl ester (JME) (Figure 24). Biodiesel production by transesterification reactions needs a catalyst. This catalyst can either be an alkali (typically KOH, NaOH) compound, an acid ( $H_2SO_4$ ) or an enzyme. In this case study potassium hydroxide (KOH) was used as an alkali catalyst.

### 7.3.3 Data collection

Our study is based on primary and up to dated data that were obtained from the experimental field of Mali in western Africa with the help of Centre for International Cooperation on Developmental Agronomic Research (CIRAD). This experimental station of Teriya Bugu is use to grow *Jatropha* and its geographic coordinates are: 13113.42N; 5129.5W. The system defines the interface of production system with the environment or with other system. It normally depends on the characteristics and function of the given system. Geographically, our system is confined between Teriya Bugu and Le Havre, France. As mentioned earlier the production span is for thirty years which starts from the seedlings in nurseries. This study takes into account all

the inputs required for cultivation of *Jatropha* plantation and oil extraction till the production of biodiesel with all associated pollutant emissions (Chauhan et al., 2010).

The average rainfall in this region was recorded 748 mm per year between 2000 and 2007 (Ndong et al. 2009). For Transportation of *Jatropha* oil from experimental site to North of France, we considered the study already carried out by our laboratory. Where oil is transported by truck for the distance of 32 km to the field station, 564 km from the station to Abidjan train and transported by boat during 6528 km of Abidjan to Havre. Transport occurs at nearly all stages of the product system. Although it represents a seemingly impactful contribution in a LCA, considering transportation or presenting the data sources on transportation is often omitted. Thus, a set protocol was drawn in order to estimate distances covered by the inputs, outputs and intermediate products of the system. The database used to obtain background data was Ecoinvent 2.1. This database predominantly contains European data, so most of the processes in this study are evaluated for European conditions. The data in the database are provided at each unit processes according to its geographical validity and clear explanation. This database use is further discussed in the next sections.

For *Jatropha* biodiesel production there is a continuous run of matters, energy through the system boundaries which is quantitatively well described by this inventory phase. Many field emissions to air, soil and water were included accordingly due to land application. These are well described by Figure 23 for process tree. Factors corresponding to the production of electricity from regional source have been used. It is also important to choose the right voltage from the three proposed in the base (low, medium and high voltage). The average voltage is chosen for industries, low voltage for domestic, commercial and agriculture. The data from natural gas are provided by networks of low and high pressure. Low pressure usually corresponds to consumption by households, businesses and farms, the high pressure being purchased by industries.

Transesterification converts almost 97% of crude oil to biodiesel with the help of reagents, catalyst, soda, methanol and acids. All of them were taken into account for inventory analysis.

From nursery to transplantation and for each cultivation year three types of fertilizers were used for fertilization.

- Potassium nitrate as N at regional storehouse/kg/RER:

This input takes into account the production of potassium nitrate from potassium chloride and nitric acid, the transport of raw materials and intermediate products to the plant and transport the fertilizer factory to store. The treatment of waste during production, and the coating and packaging of products were not included. Here RER is used for European based regional data source.

- Ammonium nitrate phosphate as  $P_2O_5$  at Regional storehouse/kg/RER:



This input takes into account the production of potassium nitrate from ammonia and phosphate rock, the transport of raw materials and intermediate products to the plant and transport the fertilizer factory to store.

- Ammonium nitrate as N at regional storehouse/kg/RER:

This input takes into account the production of potassium nitrate from ammonia and nitric acid, the transport of raw materials and intermediate products to the plant and transport the fertilizer factory to store.

- Transport through Truck Boat and Rail

Once the oil is produced locally in the pressing unit, it is sent to units that allow its conversion into biodiesel. Stages of refining and transesterification of *Jatropha* oil are usually carried away from the place of cultivation and production of oil. That is why a transport step was added with inputs for truck, train and boat. These inputs can represent all transport relative to other stages (cultivation, harvesting ...).

- Sulphuric acid (Liquid) at plant/kg/RER:

This Ecoinvent data includes a gas production containing  $\text{SO}_2$ , the conversion of  $\text{SO}_2$  to  $\text{SO}_3$  and  $\text{SO}_3$  absorption in solution (sulfuric acid in water) to give sulfuric acid. The manufacturing process includes raw materials (elemental sulfur, pyrites, ore and waste acid), as well as the consumption of auxiliary energy, infrastructure, transport auxiliary raw materials and waste. This causes the production of solid waste, air emissions and water emissions. The transport and storage of the final product sulfuric acid are not included.

- Soda powder at plant/kg/RER:

The system includes the generation of waste and emissions to air and water. The transport and storage of the final product sodium hydroxide are not included.

- Methanol at regional storage/kg/RER

Input supposed to be imported for a large part of the world. Stages of refining and transesterification are also large consumers of energy, mainly in the form of electricity and natural gas.

- Electricity medium voltage at grid/kWh/FR:

This input includes the production and import of electricity in France. It also includes the transmission network and line losses at large. These inputs are shown in the following table (Table 7) with their origin and use in respective stages.

Table 7 Input data used for Jatropha LCA

Steps	Data	Origin	Quantity
<b>Nursery, Transplantation and culture</b>			
	Fertilizer N	Cirad	104.86 kg/ha
	Fertilizer P	Cirad	168.54 kg/ha
	Fertilizer K	Cirad	79.21 kg/ha
	Water	Cirad	18,000 kg/ha
	Natural gas	Cirad	0 kg/ha
	Electricity	Cirad	0 kwh/ha
	Acid	Cirad	0 kg/ha
	Soda	Cirad	0 kg/ha
	Methanol	Cirad	0 kg/ha
	KOH	Cirad	0 kg/ha
<b>Transport</b>			
	Train	Google	676.80 km
	Barge	Google	7833.60 km
	Lorry	Google	32.00 km
<b>Oil Extraction and refining</b>			
	Natural gas	Cirad	572.00 kg/ha
	Electricity	Cirad	30 kwh/ha
	Acid	Cirad	1.50 kg /ha
	Soda	Cirad	1.50 kg/ha
<b>Transesterification</b>			
	Water	Cirad	154.38 kg/ha
	Natural gas	Cirad	967.50 kg/ha
	Electricity	Cirad	22.40 kwh/ha
	Acid	Cirad	0.76 kg /ha
	Soda	Cirad	0.00 kg/ha
	Methanol	Cirad	112.00 kg/ha
	KOH	Cirad	18.00 kg/ha

The ISO 14040 standards demand that functional units are clearly defined, measurable, and relevant to input and output processes. As for Jatropha LCA the functional unit is set to be 1 MJ release and reference flow which initiates the inventory to be made for system inputs and outputs is the quantity (in kg) of Jatropha seed required to fulfill this functional unit. All the results reported by Jatropha biodiesel corresponds to MJ, so a referenced conversion Table 8 has been presented in order to have harmony among the entire units in each process.

Table 8 Reported values for data quality from different processes (Ndong et al., 2009 Makkar and Becker 2009)

Culture	washing	Pressing	Seed cake	Refining	Transesterification	Conversion kg.MJ
Kg of grains/ha	Kg of grains	Kg of HVB	Kg of grains	Kg h.raff	Kg of biodiesel	MJ
<b>3,37</b>	3,37	1.00	2,28	0,97	0,88	<b>32</b>
<b>3,82</b>	<b>3,82</b>	<b>1,13</b>	<b>2,58</b>	<b>1,09</b>	<b>1.00</b>	<b>37</b>

## 7.4 LIFE CYCLE IMPACT ANALYSIS

Life Cycle Impact Assessment (LCIA) is the 3rd LCA phase and its main aim is to translate the environmental burdens quantified in inventory phase into related impacts. The impact assessment phase of an LCA is defined as “a quantitative and/or qualitative process to identify, characterize and assess the potential impacts of the environmental interventions identified in the inventory analysis”. It is important to mention that for impacts there are bulks of substances that have influence on the results. It is complicated to select all these substances for implementation in worksheet such as Excel. Then the weighting stage aggregates the result in specific cases when it is required. It is important to mention that selection of impact categories and LCIA model must be consistent with the goal and scope of LCA study and also it must reflect the environmental issues of the system under study. The method used for impact assessment is Impact 2002+, which is the best example of both, problem oriented (midpoint) and damage oriented (endpoint) approach. Other impact method considered further for this study is CML 2 baseline (used for validation and comparison only hence their results are not presented here). Figure 25 represents inventory analysis resulted toward impact assessment with intermediate impacts and damages.

For midpoint evaluation in Impact 2002+ methodology environmental impacts considered were Non-renewable energy requirement (MJ), Global warming (GWP) (kg CO<sub>2</sub>-eq), Ozone layer depletion (OD) (kg CFC11-eq), Acidification (kg SO<sub>2</sub>-eq), Eutrophication (Kg PO<sub>4</sub>-eq), Eco-Toxicity (Kg TEG soil), Carcinogens and Non-carcinogens (Kg C<sub>2</sub>H<sub>3</sub>Cl-eq) and Photo chemical Oxidation (Kg C<sub>2</sub>H<sub>4</sub>-eq). This method is more often a combination between Eco-indicator 99, CML 2 and IPCC with the inclusion of damage assessment, normalization and evaluation. Normally there are fourteen midpoint categories and subsequently 4 damage or endpoint categories applicable to Europe for more than 1500 compounds (Jolliet et al., 2004). For each impact categories, the share of the different contributing production phase like nursery establishment, transplantation, refining, oil extraction transesterification and end use are indicated. Impact 2002+ was chosen not only because of “midpoint” and “endpoint” calculation but also it has the impact categories which were most relevant to our study.

SimaPro takes dozens of methods as well as thousands of substances into account. It is important to identify and select only the substances that significantly influence our LCA in order to enable the Excel file for providing the same results as SimaPro. This software for LCA includes 34 methods. Each method consists of several impact categories. For our project, only the most significant impacts have been preserved after normalization.

- Substances selection criteria

As for the impact categories, it is important to select only those substances that have significant importance instead of implement the thousands of substances in the Excel file. To do so, we once again consult the results from SimaPro. For each method and for each impact

category selected above, we selected the substances that had the greatest impact after normalization. Finally, the number of substances is limited to 37 for the method Impact2002+ method instead of the thousands referenced in SimaPro. (Table 9 and Figure 26)

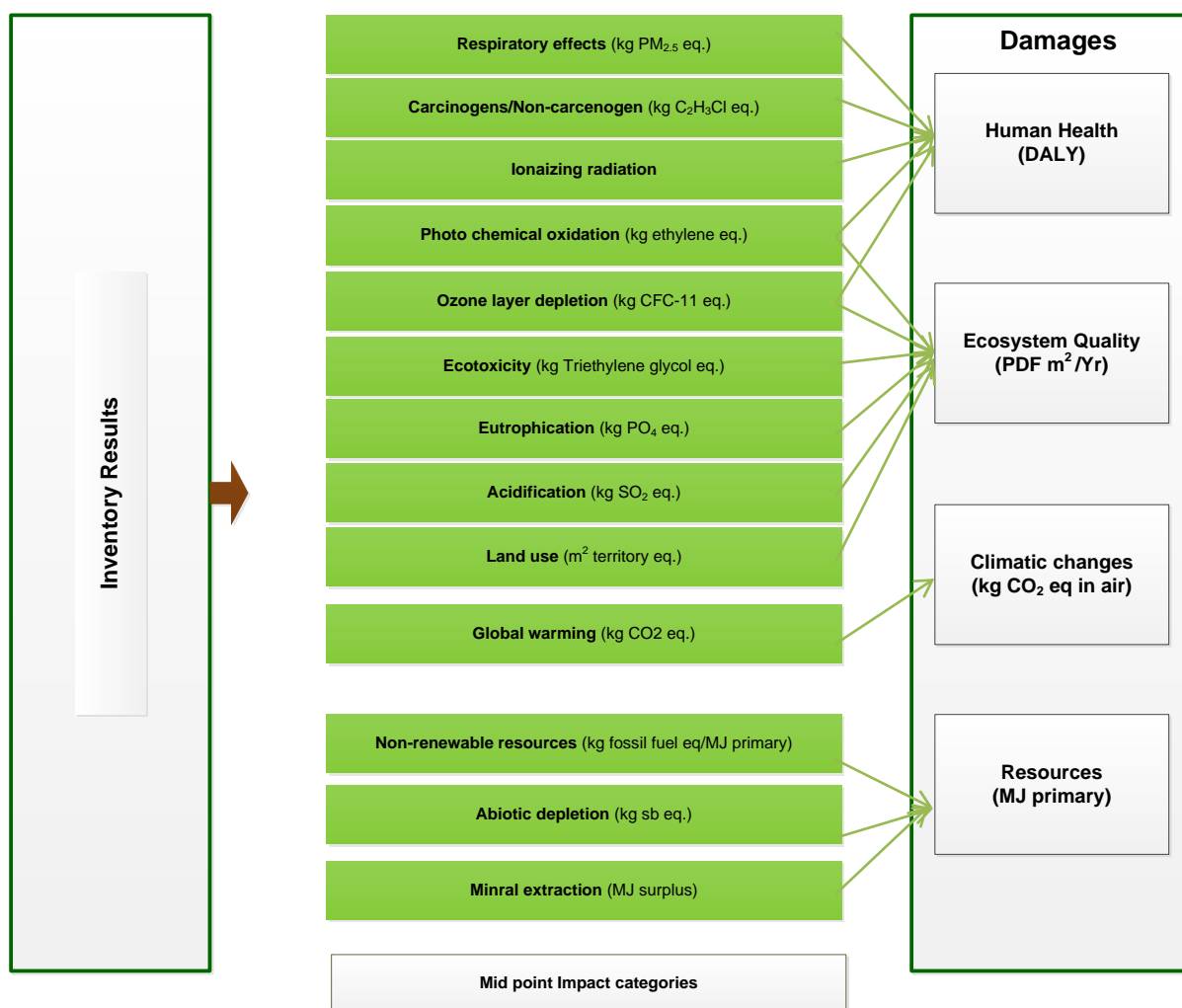

Figure 25 Representation of Inventory result toward impact assessment (Adapted from Joliet et al., 2010)

Table 9 Selection of the substances for each category in impact 2002+

	Non-renewable resources	Global warming	Ozone layer depletion	Photo chemical oxidation	Acidification/ Nutrification	Eutrophication	Carcinogens/ Non-carcinogens	Ecotoxicity
<b>Emissions to air</b>		CO <sub>2</sub> , N <sub>2</sub> O, CO, CH <sub>4</sub> , C <sub>3</sub> H <sub>8</sub>	CH <sub>4</sub> , C <sub>3</sub> H <sub>8</sub>	CH <sub>4</sub> , NMHC, C <sub>3</sub> H <sub>8</sub>	N <sub>2</sub> O, NH <sub>3</sub> , NO <sub>x</sub> , SO <sub>x</sub>		CH <sub>4</sub> , NH <sub>3</sub> , C <sub>3</sub> H <sub>8</sub>	Al, Cr, Cu, Ni, Zn
<b>Emissions to Soil</b>								Cu, Zn, Al
<b>Emissions to water</b>		Cu, Hg, Pb				Phosphate, Cd	Cu, Hg, Zn, S, Cr	
<b>Raw</b>		Coal, Natural gas, fuel/oil						

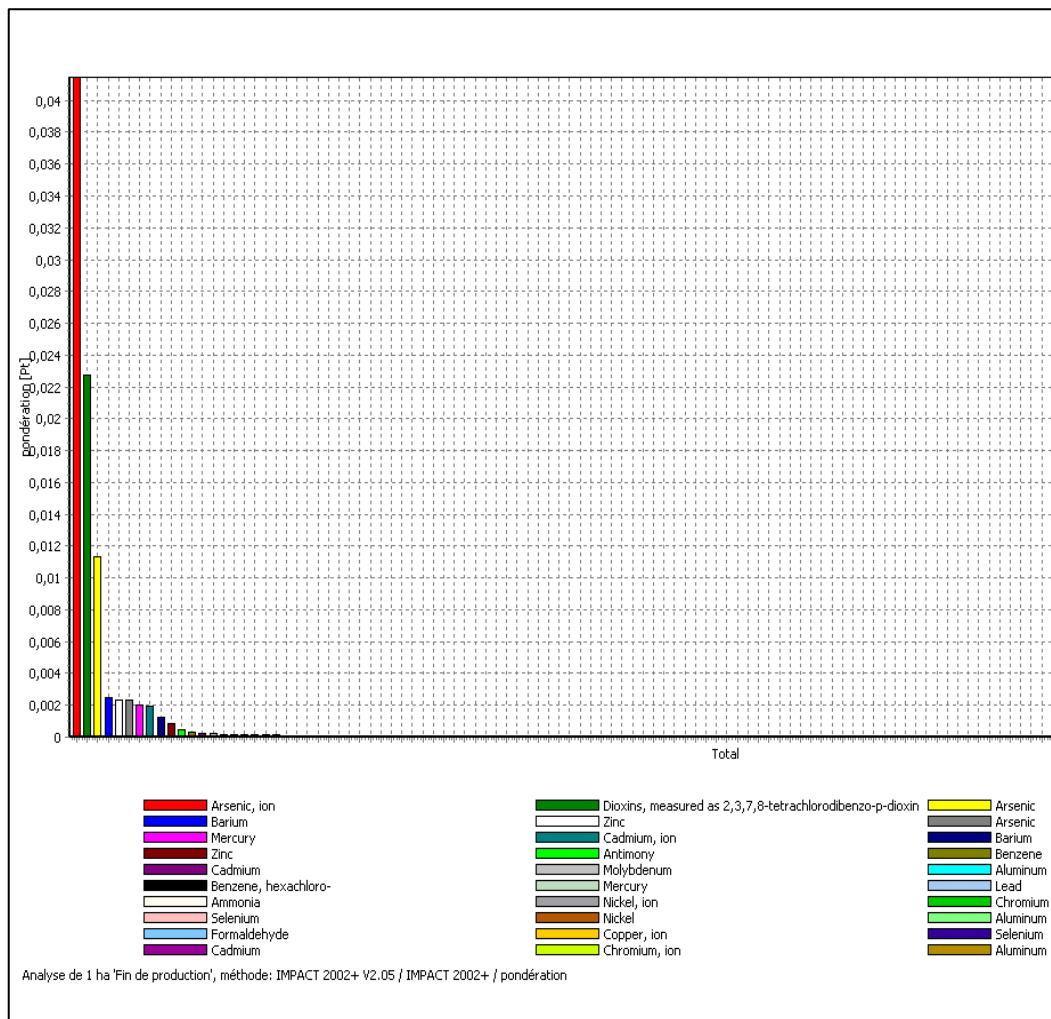

Figure 26 Example for substance selection for non-carcinogenic impact in impact 2002+

## 7.5 RESULTS

### 7.5.1 Midpoint evaluation

#### 7.5.1.1 Non-renewable energy requirement

Energy requirement must be taken into account in order to produce biofuels. This energy requirement is related to fertilizers manufacture, to run agricultural machinery, plant route to the factory where they are produced, to operate the plant, etc. Figure 27 shows impact of Jatropha-based biodiesel system for non-renewable resource depletion. The actual cultivation phase has a share of low energy consumption in comparison to all other stages like refining and Transesterification. Indeed, the transesterification stage consumes more than half (60%) of the energy consumption. This is not a common finding as there are studies which show higher energy consumption for the cultivation stage (Achten et al., 2010; Prueksakorn and Gheewala, 2008). While the other show same configuration as presented in this study (Ndong et al., 2009; Ou et al., 2009). These differences are mainly due to methodological issues and also the

exclusion and inclusion of by-products like production of machinery, polythene bags for nursery production, use of seed husks etc.

Direct or indirect energy consumption in Jatropha biodiesel production is very important which is normally accompanied by various elements. These elements are shown in Figure 23 with respect to each process in the whole cultivation and production phase. Total of 30.8 and 22.4 kWh electricity in refining and transesterification stages respectively was used for per ton production of Jatropha Methyl Ester. Through Impact 2002+ we have the total impact of non-renewable energy resources of 8015.11 MJ for first three years which belongs to the nursery and transplantation phase (Culture or plant production stage)<sup>3</sup>. From 4th year onward we got the value of 16938 MJ as an impact of non-renewable resources. It is assumed that from 4<sup>th</sup> year onward Jatropha gives a stable amount of production (rounded for consistency) and are passed through the same technique for biodiesel production. So the impact concerned to each category remains almost constant.

A study conducted by (Prueksakorn and Gheewala, 2008) shows energy output from both systems and the ratio he found was almost 6-7 which indicates a substantial benefit of Jatropha. Likewise study carried out at our Agro-industrial laboratory shows not only 72% GHG saving but also 4-7 biodiesel energy output to fossil energy input.

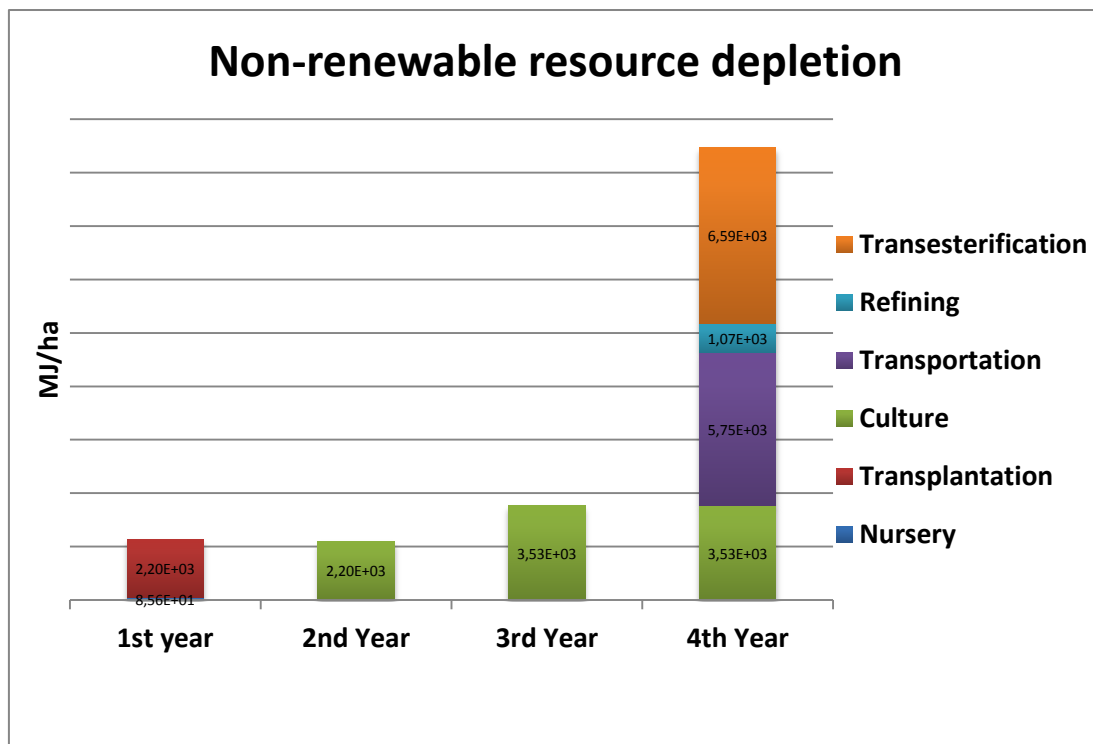

Figure 27 Non-renewable resource depletion with Impact 2002+ (\* Total years of production are 30 so the sum can be obtained by 4th yr. of production multiply by 27)

<sup>3</sup> To avoid ambiguity, culture or plant production stage is actually the sum of Nursery transplantation and culturing (3<sup>rd</sup> year). Hence their values are also summed up for each impact category

### 7.5.1.2 Global warming potential

Global warming is defined as the change in climate and in the natural phenomenon of the greenhouse effect due to the increase in anthropogenic greenhouse gases in the atmosphere. The impact of the cultivation of Jatropha on global warming has been studied by analyzing the emissions of greenhouse gases. GHG emissions were converted into CO<sub>2</sub> equivalents. The potential greenhouse effect of these gases is a conversion factor to compare the effect on the climate of each GHG, in reference to CO<sub>2</sub>. The impact of Greenhouse gases (GHG) emissions in Jatropha biodiesel production in Impact 2002+ mainly include carbon dioxide (CO<sub>2</sub>), methane (CH<sub>4</sub>), and nitrous oxide (N<sub>2</sub>O). The most important environmental impact resulting GHG emitted during the production of ammonia and nitric acid. Assessing GHG emissions from biodiesel production relies on correctly identifying and quantifying all emission sources from the inputs toward outputs. Using Impact 2002+, 620 kg CO<sub>2</sub>-eq was recorded as an impact of global warming potential for the plant production and development stage (Sum of 3years) and total of 798 kg CO<sub>2</sub>-eq was the value for 4<sup>th</sup> year onwards (Figure 28). This provides a base that the cultivation phases contribute relatively high impacts then other unitary processes of Jatropha biodiesel system. The main reason for this high contribution is the use of fertilizers and pesticides in the earlier stages of production.

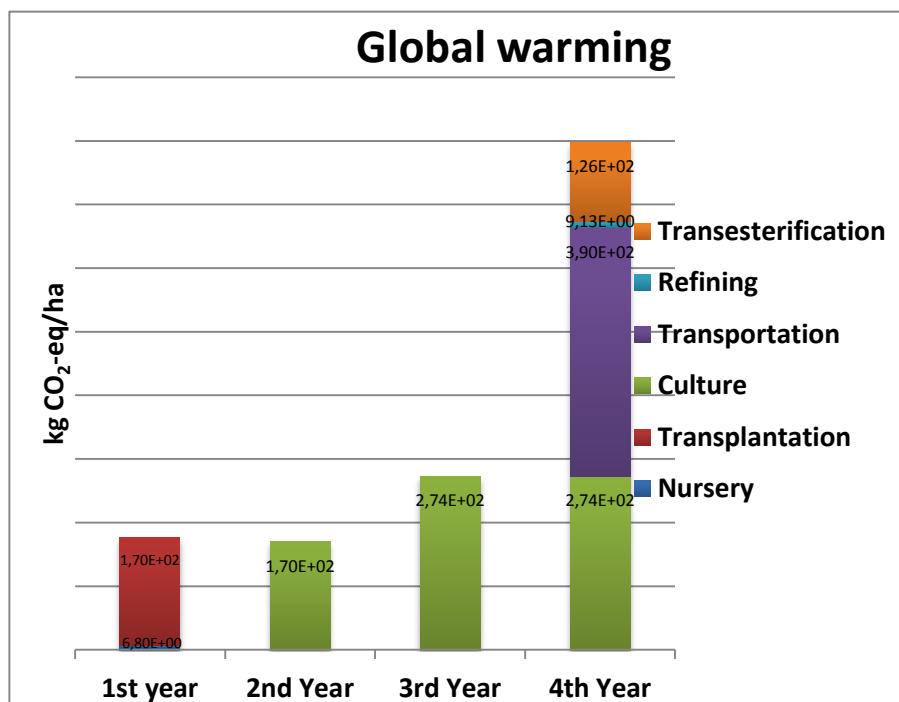

Figure 28 Global warming with Impact 2002+ (\* Total years of production are 30 so the sum can be obtained by 4th yr of production multiply by 27)

### 7.5.1.3 Ozone layer depletion

This impact highlights the deterioration of the ozone layer in the atmosphere (Figure 29). This gas layer protects us from ultraviolet rays. Halocarbons like (CFCs) prevent the formation of stratospheric ozone and thus limit the natural regeneration of the ozone layer, which causes a decrease in it. Halocarbons are synthetic halogenated compounds, in other words they are not produced by nature (chlorine, bromine, iodine and fluorine).

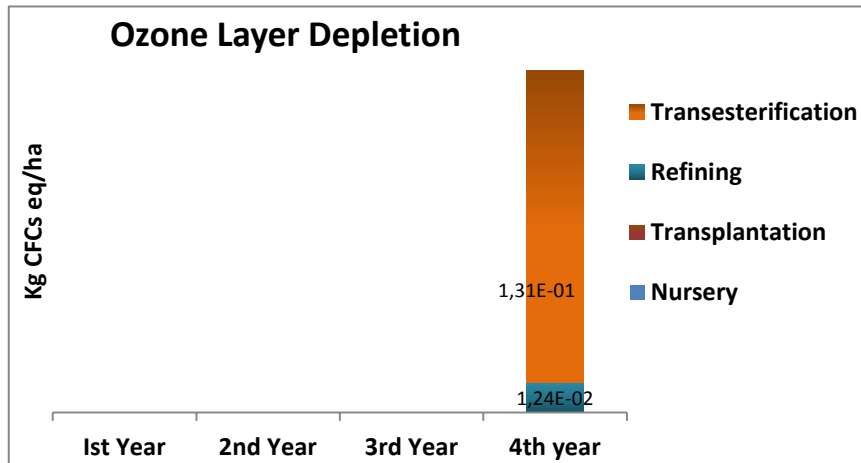

Figure 29 Ozone Layer Depletion of Jatropha through Impact 2002+ (\* Total years of production are 30 so the sum can be obtained by 4th yr of production multiply by 27)

The indicator here is the amount of CFC equivalent emitted. Damage can be skin cancer, cataracts in humans. According to Achten et al., (2010), Jatropha biodiesel has a clear advantage in order to be preferred over fossil diesel due to ozone layer depletion. Our results confirm this advantage as it showed low concentration almost equal in value to other studies (Achten et al., 2010). For Impact 2002+ we have 0.01 (1.24E-02) kg CFC11-eq and 0.14 (1.31E-01) kg CFC11-eq in the refining/transesterification and plant cultivation phases respectively.

### 7.5.1.4 Respiratory inorganics

This represents the respiratory health risks of inorganic particles released into the air from each sector or process in production. This is due mostly to airborne particles, SO<sub>2</sub> and NO<sub>x</sub> from combustion and other industrial/mechanical uses. It is being represented as the amount in kg of ethylene released to the air In this study a total of 0.63 kg C<sub>2</sub>H<sub>4</sub> eq. (Sum of 3 years) of respiratory inorganics was observed for the first three years of plant production and 1.05 kg C<sub>2</sub>H<sub>4</sub> eq for the year 4<sup>th</sup> onwards (Figure 30).



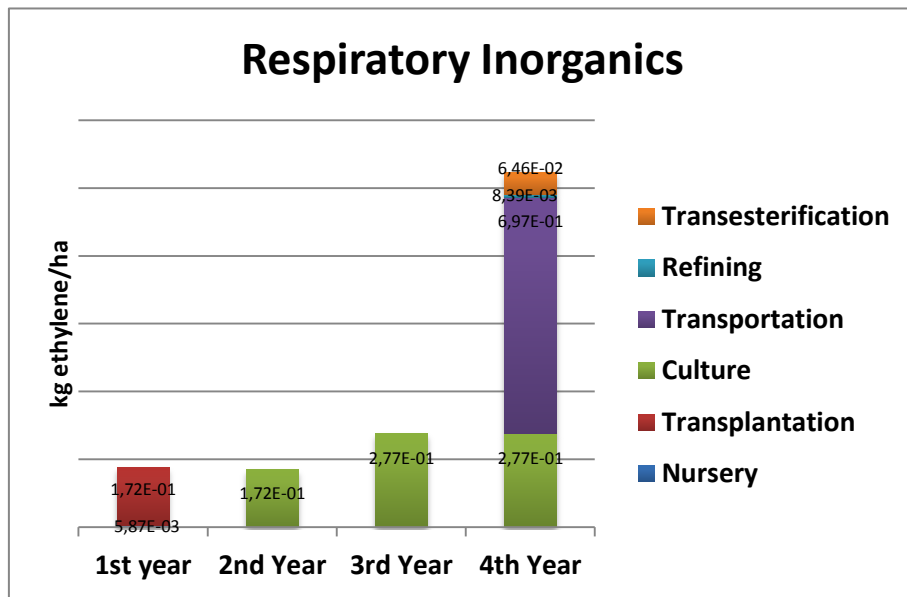

Figure 30 Respiratory Inorganics with Impact 2002+ (\* Total years of production are 30 so the sum can be obtained by 4th yr of production multiply by 27)

#### 7.5.1.5 Photo chemical oxidation

This impact reflects the creation of ozone by reactions involving ultraviolet rays, heat and pollutants kinds of nitrogen oxide and volatile organic compounds. The indicator of this impact is the amount of ethane equivalent emitted. Ozone is a strong oxidant; it affects the human toxicity level, respiratory problems and eye irritation. It can also disrupt the photosynthetic activity of plants (Figure 31).

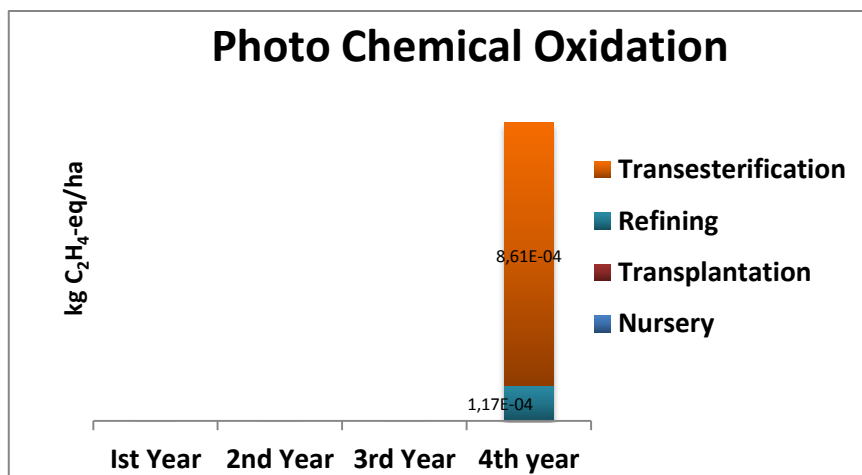

Figure 31 Photo Chemical Oxidation of Jatropha through Impact 2002+ (\* Total years of production are 30 so the sum can be obtained by 4th yr of production multiply by 27)

### 7.5.1.6 Eco toxicity

This category involves substances released to the soil, such as heavy metals, that affect plants or animal life such as worms in the soil. Ash from the boilers, corn farming operations and transportation differences are contributing processes. It is being represented as the amount of triethylene glycol (TEG) in kg equivalent released into soil and water. The ecotoxicity (Figure 32) concerns also show higher impact from year 4th onwards i.e. 9510 kg TEG eq and 7517 kg TEG eq for 1st three years (cultivation phase) respectively.

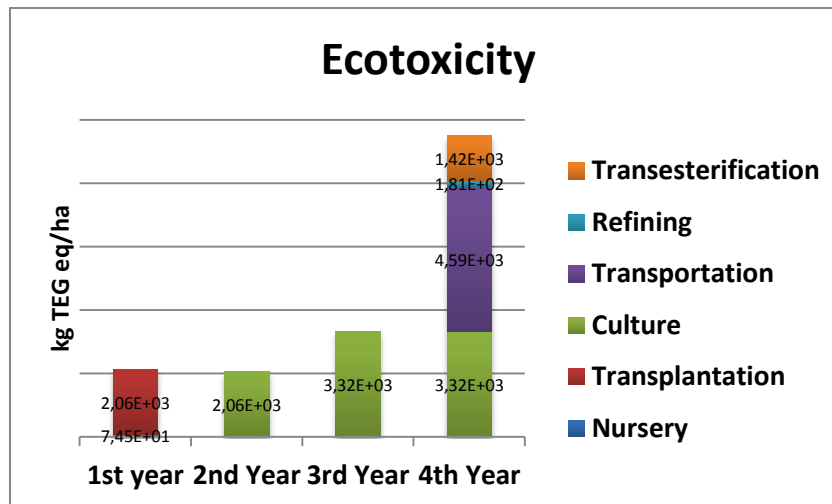

Figure 32 Ecotoxicity impact with Impact2002+ (\* Total years of production are 30 so the sum can be obtained by 4th yr. of production multiply by 27)

### 7.5.1.7 Acidification

Acidification (Figure 33) is a phenomenon which, as its name suggests increases the acidity of the soil, a river or air due to human activities. The increase in the acidity of the air is mainly due to emissions of  $\text{SO}_2$ ,  $\text{NO}_x$  and HCl, which, by oxidation, give acids  $\text{HNO}_3$  and  $\text{H}_2\text{SO}_4$ . These impacts are caused by the introduction of acids and compounds like methanol and soda in the refining and Transesterification phase. Different than what we found in our previous impact categories, acidification and eutrophication potential has then higher impacts for transesterification than grain production in Impact 2002+. The resulted values are 19.61 kg  $\text{SO}_2$ -eq (sum of 3 years) for cultivation phase and 34.21 kg  $\text{SO}_2$ -eq (sum of all phases in 4<sup>th</sup> year) for transesterification phase in Impact 2002+. This acidification is generally due to the application of manure to the fields, followed by emissions during the combustion of oil in engine.

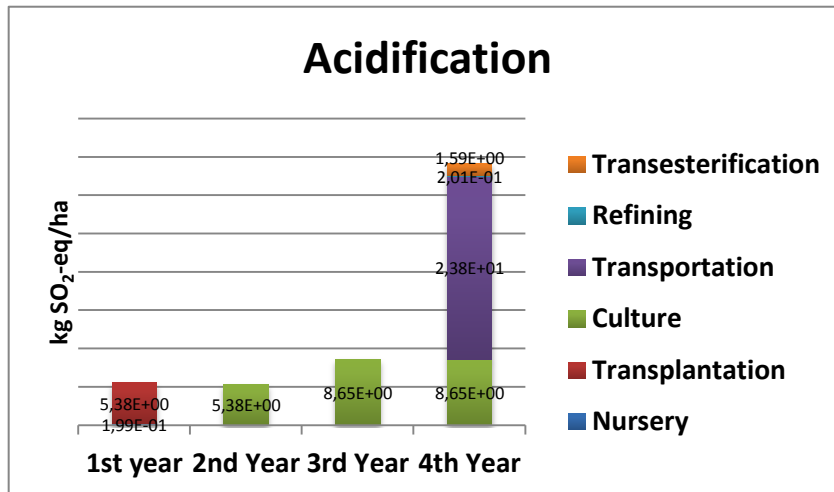

Figure 33 Acidification with Impact2002+ (\* Total years of production are 30 so the sum can be obtained by 4th yr. of production multiply by 27)

### 7.5.1.8 Eutrophication

The phenomenon is excessive enrichment of medium nutrients (nitrogen, phosphorus) released to water. Emissions of pollutants that have an impact of eutrophication (Figure 34) on environment are converted into kg PO<sup>4-</sup> eq. Likewise there is eutrophication impact which is 0.015kg PO<sup>4-</sup> eq for 1st three years and 1.83 kg PO<sup>4-</sup> eq for biofuel production phase. This is mainly due to nitrogen and phosphorus compounds contribute mainly to aquatic culturing. A too large input of these nutrients lead to ecological cause-effect chain and oxygen depletion is one of the effects. Oxygen depletion can be the result of oxygen-consuming processes emission caused by the use of these nutrients which improve the acidification and eutrophication score.

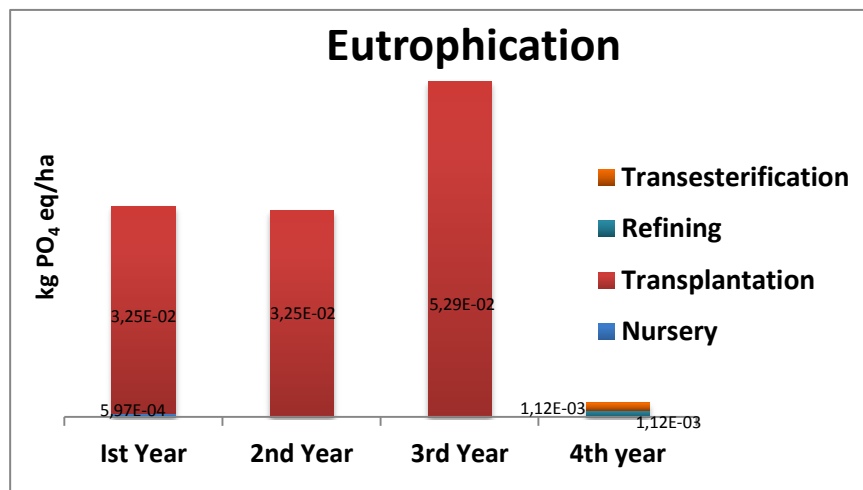

Figure 34 Eutrophication Impact of Jatropha through Impact 2002+ (\* Total years of production are 30 so the sum can be obtained by 4th yr. of production multiply by 27)

### 7.5.1.9 Carcinogens and Non-carcinogens

This highlights the toxicological risk and potential impacts of carcinogenic chemicals and non-carcinogenic chemicals released into the air, water, soil, and agricultural soil from each process of production (kg Vinyl chloride eq). Values obtained from the IMPACT 2002+ methodology showed an impact of 17.56 kg C<sub>2</sub>H<sub>3</sub>Cl eq for the 1<sup>st</sup> three years and 89.48 kg vinyl chloride eq from 4<sup>th</sup> year onwards (Figure 35).

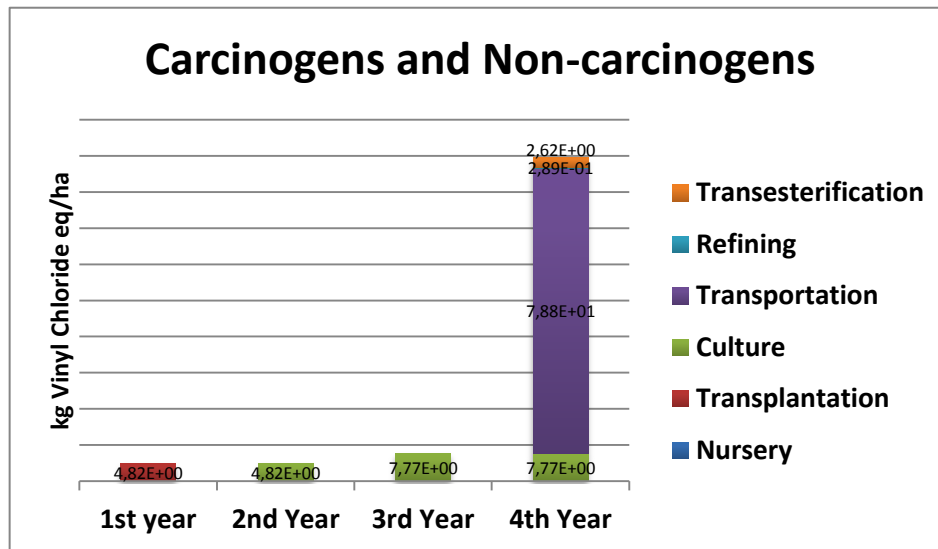

Figure 35 Carcinogens and Non-carcinogens with Impact2002+ (\* Total years of production are 30 so the sum can be obtained by 4th yr. of production multiply by 27)

### 7.5.2 Damage evaluation

LCA of Jatropha production to biodiesel production was evaluated for a life cycle of 30 years. Damage categories were then calculated at the end of this evaluation of each impact category. This endpoint or damage category evaluation helps to find out the net burden on human health, climate change, ecosystem and resources depletion with the respective contribution of each individual category. The damage characterization factors of any substance can be obtained by multiplying the midpoint characterization potentials with the damage characterization factors of the reference substances. Human toxicity (carcinogenic and non-carcinogenic effects), respiratory effects (inorganics and organics), ionizing radiation, and ozone layer depletion all contribute to human health damages (Figure 36). The unit per functional unit refers to human health is DALY (Disability Adjusted Life Years) that combines the burden of mortality and morbidity (non-fatal health problems) into a single number.

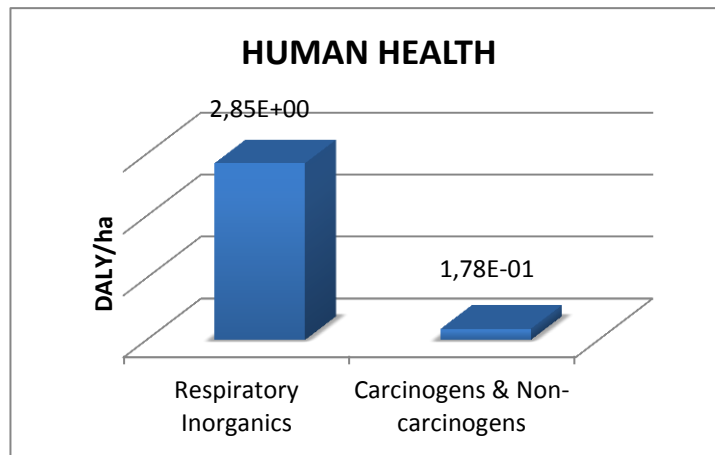

Figure 36 Human health characterization with Impact 2002+

The midpoint categories terrestrial acidification, terrestrial nitrification, and land occupation were responsible for ecosystem quality. Their impact can directly be determined as a potentially disappeared fraction (PDF·m<sup>2</sup>·year) over a certain area and during a certain time (Figure 37).

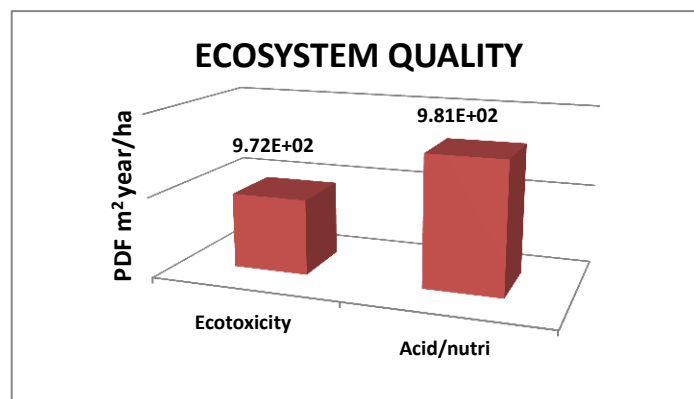

Figure 37 Ecosystem characterization with Impact 2002+

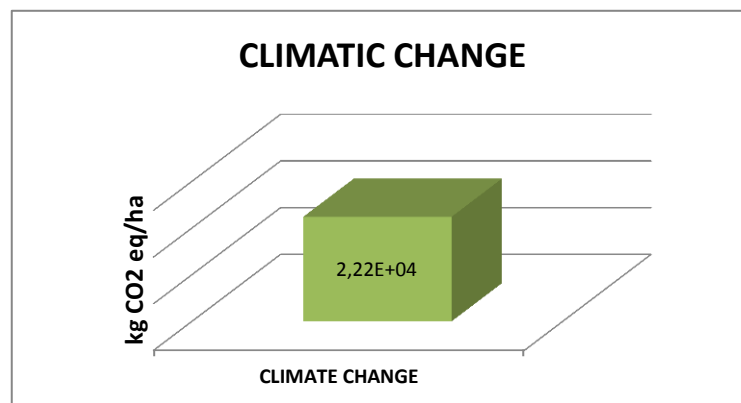

Figure 38 Climatic change characterization with Impact 2002+

Modeling up to the damage of the impact of climate change on ecosystem quality and human health is not accurate enough to derive reliable damage characterization factors thus the interpretation directly takes place at midpoint level for climatic change.

The global warming is considered as a stand-alone endpoint category with units of climatic change (kg CO<sub>2</sub> eq.) in Figure 38, which is normalized in the next step. Then the two midpoint categories contributing to the resource endpoint category are mineral extraction and nonrenewable energy (MJ) consumption (Figure 39).

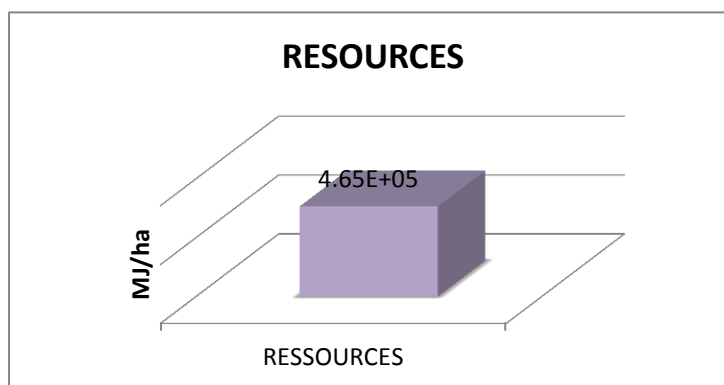

Figure 39 Non-renewable energy characterization with Impact 2002+

## 7.6 UNCERTAINTY ANALYSIS

In traditional LCA we do not perform quantitative uncertainty analysis. However, in the absence of associated uncertainty, the reliability of assessment results cannot be understood or ascertained (Lo et al., 2005). Gillani et al., (2010) observed in the review of LCA, a wide diversion of results in between LCA studies. This variation can be explained by two different factors: the limits of LCA methodology and the lack of scientific background knowledge. LCA was first established for industrial production; so that differences between industrial and agricultural systems originate many methodological problems for agricultural LCA. The fact that industrial systems are mostly independent of their local environment has led to a site-independent methodology for LCA. However, the life cycle steps in close contact with the environment (such as agriculture production) are site-dependent by nature (Bessou et al., 2009). The first consequence is the difficulty of collecting data sets of representative quality. Agricultural data sets are time and site dependent, which implies uncertainty in modeling and further variability in biofuel chain assessments.

The difficulty in comparison of diverse scenario outputs is due to varying quality of input data. The lack of transparency and homogeneity in background assumptions between different biofuel chain assessments may hide the fact that data might not always be reliable. To deal with data quality and uncertainties, we used certain tools i.e. a “pedigree matrix” that permits one to establish data quality indicators (DQIs) that give scores to data sets (1 to 5) in function of their

reliability, their completeness, and their temporal, geographical and further technological correlations linked to the goal and scope of the study (Weidema and Wesnaes, 1996). These scores make it possible to distinguish processes and flows for which input data quality is poor, and to focus on these inventory parts to compare their impacts on output data among different assessments. This qualitative approach is to be completed with statistical indicators, such as coefficient of variation, that highlight the data uncertainty: i.e. the basic uncertainty linked to typical measurement errors or normal fluctuation of the variables. In this study we used the same pedigree matrix in order to make our data more reliable. The results of our uncertainty analysis are displayed as graph with high/low intervals and through statistical data tables in the next sections. In an inventory it refers to the lack of certainty of the inventory components resulting from the data or the way it was dealt with. Uncertainty analysis ascertains and quantifies the fitness of an LCI result through a systematic procedure that measures the cumulative effects of input uncertainty and data variability. It models uncertainties in the inputs to an LCA and propagates them to results.

Till now very few LCA studies consider the uncertainties analysis. Even then this aspect was identified as key point for the improvement of present methodology. If the total uncertainty of LCA is greater than the difference of final impacts between all different scenarios, then no conclusion can be drawn. The quantification of these uncertainties is therefore a need to address. In this study, the quality of the data, at first, was estimated individually. Data limitations prevented a thorough evaluation of uncertainty. Many important parameters have not been studied in enough detail to enable proper characterization of variability and uncertainty, to identify causal relationships between parameters, and, in some cases, to even establish plausible value ranges for the parameters.

Only errors encountered during the inventory phase are quantified here. The approach is to evaluate the uncertainties related to the difference between the actual data available and the one that was provided by the database Ecoinvent 2.1. Here indicators developed by Weidema and Wesnaes, (1996) were used. These concern the reliability of data completeness, geographical, temporal and technological correlations and sample size. The approach is to assign these six indicators and then they were divided into five quality levels with a score of 1 to 5 accordingly. A score assigned by each indicator is an uncertainty factor shown in the following table. Variance with a confidence interval of 95% is calculated from the detailed formula given below:

*Equation 5 Calculation of standard deviation in uncertainty analysis*

$SD_{95}$

$$= \exp\sqrt{[\ln(U_1)]^2 + [\ln(U_2)]^2 + [\ln(U_3)]^2 + [\ln(U_4)]^2 + [\ln(U_5)]^2 + [\ln(U_6)]^2 + [\ln(U_b)]^2}$$

*U1 = Uncertainty factor of reliability    U2 = Uncertainty factor of Completeness    U3 =  
Uncertainty factor of Temporal correlation    U4 = Uncertainty factor of Geographic correlation  
U5 = Uncertainty factor of other technological correlation    U6 = Uncertainty factor of sample size  
Ub = Basic uncertainty factor*

The analyzed data set has diverse units and widely different averages. Hence, the coefficient of variation (CV) is a preferable interpretation basis in detriment of the standard deviation (Weidema and Wesnaes, 1996). Table 10 gives detail of these calculations. It is possible to see that database derived data does not accumulate significant variation in global warming, non-renewable energy and terrestrial acidification/nitrification, but does so significantly in ozone layer depletion and land occupation. One might refrain himself to assign lesser fitness to these categories for the results proceeding from methodology or LCI.



Table 10 Quality indicator and data uncertainty analysis (Weidema and Wesnaes, 1996)

Indicator	Quality score				
	1	2	3	4	5
<b>Reliability</b>	Measurement based verified data <i>F=1.00</i>	Verified data partially based on assumption or non-verified data based on measurement <i>F=1.05</i>	Non-verified data partly based on assumptions <i>F=1.10</i>	Qualified estimate (e.g. by industrial experts) <i>F=1.20</i>	Non-qualified estimate or unknown origin <i>F=1.50</i>
<b>Completeness</b>	<i>Representative data from sample over adequate period</i> <i>F=1.00</i>	<i>Representative data from a smaller number of sites but for adequate period</i> <i>F=1.02</i>	<i>Representative data from an adequate number of sites but from shorter periods</i> <i>F=1.05</i>	<i>Representative data but from a smaller number of sites and shorter periods or incomplete data from an adequate number of sites and periods</i> <i>F=1.10</i>	<i>Representativeness unknown or incomplete data from a smaller number of sites and/or from shorter periods</i> <i>F=1.20</i>
<b>Temporal correlation</b>	Less than 3 years of difference to year of study <i>F=1.00</i>	Less than 6 years of difference <i>F=1.03</i>	Less than 10 years of difference <i>F=1.10</i>	Less than 15 years of difference <i>F=1.20</i>	Age of data unknown or more than 15 years of difference <i>F=1.50</i>
<b>Geographic correlation</b>	Data from area under study <i>F=1.00</i>	Average data from larger area under study is included <i>F=1.01</i>	Data from area with similar production conditions <i>F=1.02</i>	Data from area with slightly similar production conditions <i>F=(-)</i>	Data from unknown area or area with very different production conditions <i>F=1.10</i>
<b>Technological correlation</b>	Data from enterprises, processes and material under study <i>F=1.00</i>	Data from processes and materials under study but from different enterprises <i>F=(-)</i>	Data from processes and materials under study but from different technology <i>F=1.20</i>	Data on related processes or materials but from same technology <i>F=1.50</i>	Unknown technology or data on related processes or materials, but from different technology <i>F=2.00</i>
<b>Sample size</b>	>100 continue measurement <i>F=1.00</i>	>20 <i>F=1.02</i>	>10 <i>F=1.05</i>	≥3 <i>F=1.10</i>	Unknown <i>F=1.20</i>

Table 11 Uncertainty analysis for *Jatropha* LCI

Steps	Data	Origin	Reliability	Completeness	Temporal correlation	Geographic correlation	Technological correlation	Sample size	Basic uncertainty	Variance (With 95% confidence interval)	Relative uncertainty of values in %
<b>Nursery, Transplantation and culture</b>											
	Fertilizer N	Cirad	1	1	1	1,01	1	1,00	1,01	0,5%	
	Fertilizer P	Cirad	1	1	1	1,01	1	1,00	1,01	0,5%	
	Fertilizer K	Cirad	1	1	1	1,01	1	1,00	1,01	0,5%	
	Water	Cirad	1	1	1	1,01	1	1,00	1,01	0,5%	
	Natural gas	Cirad	1	1	1	1,01	1	1,00	1,01	0,5%	
	Electricity	Cirad	1	1	1	1,01	1	1,00	1,01	0,5%	
	Acid	Cirad	1	1	1	1,01	1	1,00	1,01	0,5%	
	Soda	Cirad	1	1	1	1,01	1	1,00	1,01	0,5%	
	Methanol	Cirad	1	1	1	1,01	1	1,00	1,01	0,5%	
	KOH	Cirad	1	1	1	1,01	1	1,00	1,01	0,5%	
<b>Transport</b>											
	Train	Google	1	1	1	1	1	1,00	1	0,0%	
	Barge	Google	1	1	1	1	1	1,00	1	0,0%	
	Lorry	Google	1	1	1	1	1	1,00	1	0,0%	
<b>Oil Extraction and refining</b>											
	Natural gas	Cirad	1,05	1,05	1	1	1	1,00	1,07	3,5%	
	Electricity	Cirad	1,05	1,05	1	1	1	1,00	1,07	3,5%	
	Acid	Cirad	1,05	1,05	1	1	1	1,00	1,07	3,5%	
	Soda	Cirad	1,05	1,05	1	1	1	1,00	1,07	3,5%	
<b>Transesterification</b>											
	Water	Cirad	1	1	1	1,01	1	1,00	1,01	0,5%	
	Natural gas	Cirad	1,05	1	1	1,01	1	1,00	1,05	2,5%	
	Electricity	Cirad	1,05	1	1	1,01	1	1,00	1,05	2,5%	
	Acid	Cirad	1,05	1	1	1,01	1	1,00	1,05	2,5%	

Soda	Cirad	1,05	1	1	1,01	1	1,00	1,05	2,5%	
Methanol	Cirad	1,05	1	1	1,01	1	1,00	1,05	2,5%	
KOH	Cirad	1,05	1	1	1,01	1	1,00	1,05	2,5%	
<b>Emissions to water</b>										
DBO, DCO,COD,COT	Ecoinvent	1	1	1	1,01	1,2	1,00	1,2	9,6%	
Inorganic composites (NH <sub>4</sub> , PO <sub>4</sub> , NO <sub>3</sub> , Na etc.)	Ecoinvent	1	1	1	1,01	1,2	1,00	1,2	9,6%	
Hydrocarbons	Ecoinvent	1	1	1	1,01	1,2	1,00	1,2	9,6%	
Heavy metals	Ecoinvent	1	1	1	1,01	1,2	1,00	1,2	9,6%	
From agriculture: NO <sub>3</sub> , PO <sub>4</sub>	Ecoinvent	1	1	1	1,01	1,2	1,00	1,2	9,6%	
From agriculture: Heavy metals	Ecoinvent	1	1	1	1,01	1,2	1,00	1,2	9,6%	
<b>Emissions to air</b>										
CO <sub>2</sub>	Ecoinvent	1	1	1	1,01	1,2	1,00	1,2	9,6%	
SO <sub>2</sub>	Ecoinvent	1	1	1	1,01	1,2	1,00	1,2	9,6%	
NO <sub>x</sub> , NMVOC total, methane, N <sub>2</sub> O, NH <sub>3</sub>	Ecoinvent	1	1	1	1,01	1,2	1,00	1,2	9,6%	
CO	Ecoinvent	1	1	1	1,01	1,2	1,00	1,2	9,6%	
Hydrocarbons	Ecoinvent	1	1	1	1,01	1,2	1,00	1,2	9,6%	
Heavy metals	Ecoinvent	1	1	1	1,01	1,2	1,00	1,2	9,6%	
Emissions from process: COV individual	Ecoinvent	1	1	1	1,01	1,2	1,00	1,2	9,6%	
Emissions from process: CO <sub>2</sub>	Ecoinvent	1	1	1	1,01	1,2	1,00	1,2	9,6%	
From agriculture: CH <sub>4</sub> , NH <sub>3</sub>	Ecoinvent	1	1	1	1,01	1,2	1,00	1,2	9,6%	
From agriculture: N <sub>2</sub> O, NO <sub>x</sub>	Ecoinvent	1	1	1	1,01	1,2	1,00	1,2	9,6%	
Emissions from process: other inorganic emissions	Ecoinvent	1	1	1	1,01	1,2	1,00	1,2	9,6%	
<b>Emissions to soil</b>										
Oil, hydrocarbons total	Ecoinvent	1	1	1	1,01	1,2	1,00	1,2	9,6%	
Pesticides	Ecoinvent	1	1	1	1,01	1,2	1,00	1,2	9,6%	
Heavy Metals	Ecoinvent	1	1	1	1,01	1,2	1,00	1,2	9,6%	

## 7.7 DISCUSSION

### 7.7.1 Comparison of other studies

LCA studies in the context of results can be difficult to compare directly due to differences in selection of system boundaries, site-specific conditions, different functional units, and other variations in modeling assumptions. However, attempts were made to compare the results of this study to other comprehensive *Jatropha* biodiesel LCAs previously published. Reinhardt et al., (2007) evaluated biodiesel use in passenger cars as opposed to locomotives and expressed the results on a per hectare-year (ha-yr) basis as opposed to per gross tonne-kilometer transported. Further investigation into the source(s) of the discrepancy is a high priority for future research on this topic. Prueksakorn and Gheewala, (2008) reported net energy ratio (NER) for *Jatropha* biodiesel production in Thailand. They cited co-product yield assumptions, fertilizer and irrigation requirements, and transportation distances as having the greatest impact on NER. Again, it is difficult to determine exact reasons that account for the discrepancy but here we provide a Table 12 related to some of the recent *Jatropha* LCAs. Pandey et al., (2011) examined the life cycle energy balance for *Jatropha* biodiesel production and greenhouse gas emissions from post-energy use and end combustion of biodiesel, over a period of 5 years. Their result through the comparison with other study found that average yield per hectare of their study was eight times to that of the literature study with low input system. Achten et al., (2010a) evaluated life cycle energy balance over a period of 20 years. They achieved a yield of 1.7 tones/ha with a plant density as 2600 plants/ha through the use of fertilizer N, P and K (ratio 111, 111, 0). Then Wang et al., (2011) performed a lifecycle assessment of the economic, environmental and energy (3E) performance of the *Jatropha* biodiesel, assuming that *Jatropha* oil is used for direct blending with diesel or as *Jatropha* methyl ester (JME). Their results show that, at the current technical levels, the production of *Jatropha* biodiesel is financially infeasible, but has positive environmental and energy performance.

Table 12 Comparisons between *Jatropha* based LCA studies

Reference	Origin	Chain of production	Plants/ha	Life of plant	Fertilizer N,P,K/ha	Yield in tonnes/ha	Tonnes of JME/ha	CO <sub>2</sub> kg eq/MJ JME	% reduction GHG	Functional Unit used
Present study	Mali-France	Long chain	1200	30	72,116,54	4	1.2	24	70%	MJ
Reinhardt et al., 2007	NA-Germany	Long chain	1660	20	48,19,53	1.4	0.36	74.5	11%	MJ
Prueksakorn and Gheewala (2008)	Thailand	Long chain	1100-3300	20	160,26,63	2.7	1.4	NA	NA	ha
Pandey et al., 2011	India	Short chain	2500	5	25 kg urea	5	0.6	91	75%	ha
Achten et al., 2010a	India	Long chain	2600	20	111,111,0	1.7	0.45	34.2	65%	MJ
Wang Z et al., 2011	China	Short chain	1650	30-50	0,15	1.48	NA	97	NA	ha
Ndong et al., 2009	Ivory cost	Long chain	1111	30	108,25,30	4	1.05	23.5	72%	MJ

---

Choosing between different impact methodologies (i.e. Impact 2002+, CML 2 Baseline, TRACI, ReCiPe 2008 etc...) had great impact on the outcome of this study and the studies present in the literature. This means more subjectivity to the reliability and treatment of data. Though, being a generic life cycle assessment, one expects errors in the outcome of study. Facing a screening approach to the *Jatropha* based biodiesel life cycle, we handle to main difficulties regarding data acquirement: scarcity of information and its originality. While the limitations imposed by scarcity are clear, the origin of the data holds more complex consequences i.e. African origin and European conditions. Data proceeding from literature is patent mainly in other LCA or energy efficiency studies previously done. Therefore, it already carries manipulation inherent to the studies' methodologies. Cherubini et al., (2009) claim that inexact quantification of environmental impacts of bioenergy systems is, so far, unavoidable owing to the out number of variables involved. They suggest that the presentation of LCA results is preferable by displaying probable ranges. However, the Monte Carlo analysis results were kept apart to avoid more confusion in the illustration of our result chart. For example, the supposition of electricity from coal has a strong impact on changing the whole scenario of the environmental impact of using seed cake for electricity generation. Same for the using other source of electricity vice versa.

This study is further limited by the left-out analysis parameters. On assessing the *Jatropha* biodiesel system's sustainability, it would have been of outmost importance to include social-economic deliberation. Without this aspect, the performed assessment cannot be considered a complete evaluation. The environmental assessment, itself, was restricted to few categories, which we considered the most representative of environmental performance. However, some variables that would work as stressors were left out of care, namely land-use change and carbon foot print. Land occupation and land use are contemplated, but the effects of land use transformation and the correlated carbon stock were included for SimaPro. The codes achieve that by computing the effect of waterborne emissions in target species through the two distinct biochemical damage processes and returning a damage/impact score of the FU. These species are strictly terrestrial and therefore one must bear in mind that the eutrophication and acidification impact assessment of this study is restricted to terrestrial ecosystems. Overall, the results are dependent also on the impact assessment methods chosen. This methodology has qualitative differences and yield qualitatively different results. Impact 2002+ was chosen for allowing assessment and interpretation in successive phases for midpoint and damage assessment.

By comparing the results of biofuel with that of fossil fuels from the literature, we noted that fossil fuels have a very strong impact in the consumption of energy resource depletion fossil fuels and climate change as shown in the Table 13. If we only look at climate change and the energy resource depletion it is biofuel that is least responsible for causing impact. However, if we look at the categories eutrophication and acidification results are reversed.

Table 13 Comparison of fossil fuels with biofuels (Source: ADEME 2013)

IMPACTS	JATROPHA	FOSSIL FUEL
Energy Balances/ Resource Depletion		++++
Global Warming and GHG		++++
Eutrophication	++	
Acidification	++	

### 7.7.2 Choosing between LCIA methods

The advantages and disadvantages of using different LCIA methods and indicators have been discussed in the literature e.g. (Bare, 2002). Some of them prefer midpoint indicators which describe the impacts earlier in their cause effect mechanism. This is due to additional uncertainties and forecasting considered necessary for the modeling which are closer to end point (Pennington and Rydberg, 2005). These methods are more transparent and easier to adopt by non-specialists as they do not incorporate further weighting factors but also allow decision makers to derive their own weighting using various socio-economic techniques (Bare, 2002). On the other hand, some argue that choosing indicators later in the technique closer to end point facilitate more systematic and explicit weighting across impact categories, these weighting results are often difficult to interpret and couldn't be understand easily.

As this LCA is intended to study the environmental impacts of the use a biofuel obtained from the seeds of Jatropha. The environmental impacts are considered; global warming, the ozone depletion, photochemical oxidation, acidification and eutrophication, depletion of resources, consumption of nonrenewable energy and toxicity. The overall results in the study are dependent on Impact 2002+ methodology. Also the comparison between different methodologies with almost same impact categories having similar units shows that the outcomes are not consistently similar. For example if we chose the same category like global warming for methodologies like Impact 2002+ and CML 2 baseline (results presented in appendixes 15.2). Their values differ in a slight manner as for Impact 2002+ nitrogen dioxide has a value of 156 Kg CO<sub>2</sub>-eq and for CML 2 baseline the same substance has 296 Kg CO<sub>2</sub>-eq. This surely has an effect on the outcome of our results. A theoretically thought relationship between the inputs, emissions and relative environmental impacts are of course the driver for determining the guidelines to carry out this study.

Since very limited information are available regarding acidification, eutrophication and other less mentioned LCA impact categories of the Jatropha production cycle, no statements or prognoses are made concerning these issues. Increase investigation of the cultivation step for the production of Jatropha bio-diesel enable researchers to assess the specific contribution of

Jatropha in these impacts as well. Due to the toxicity of the Jatropha seeds and oils, some attention should be paid to the human health and environment impact categories. The fruits contain irritants affecting pickers and manual dehullers. Although Jatropha has a very long history as medicinal plant, accidental intake of seeds and/or oil can cause severe digestion problems. Also the use of the seed cake as fertilizer in edible crop production raises bio-safety questions.

**7.7.3 Comparison of results between SimaPro and Excel based LCA**

Jatropha LCA was carried out with both Excel and SimaPro for validation purpose. There is always a slight difference of between these results and the fact is that SimaPro takes into account all the substance present in the data base i.e. Ecoinvent for inventory analysis. While on the other hand for Excel one has to stick with the most important one. Taking all the substance into account is a time consuming task with very low impact on the generated results for impact assessment.

The following graphs are used to compare results between SimaPro tool and Excel for the whole life cycle of Jatropha (30 years of production). The two mentioned methodologies were used for both Excel and SimaPro. In any case, the results between the two tools are similar enough to allow the same conclusions on LCA which must nevertheless be specific to the production of biodiesel from Jatropha. Figure 40 and Figure 41 show the normalized impact resulted from SimaPro and Excel respectively on the basis of 30 years of life cycle of Jatropha biofuel production with Impact2002+.

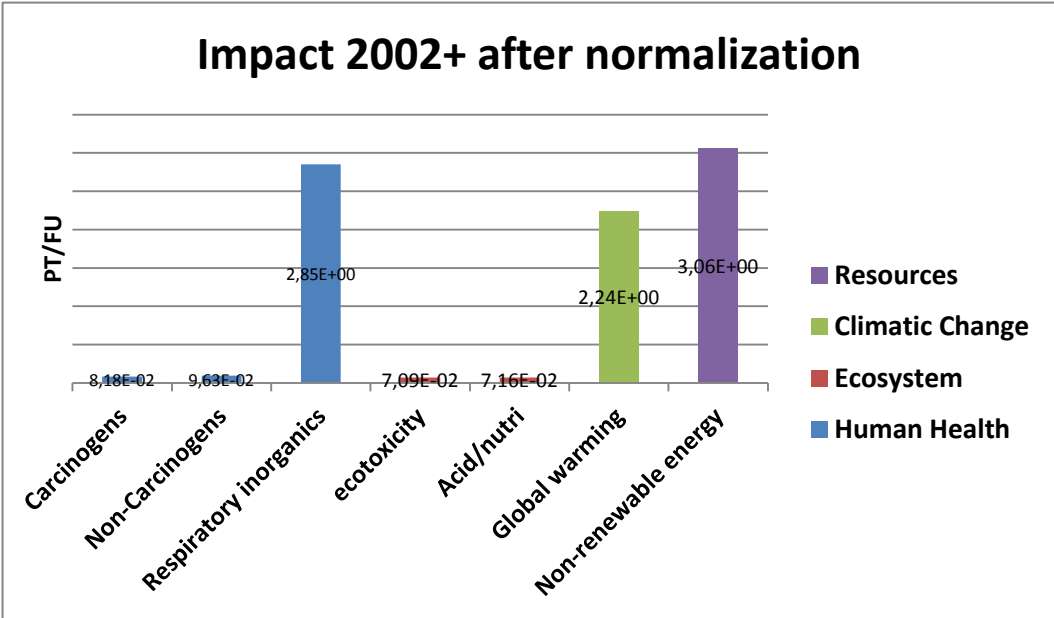

Figure 40 Excel Normalized Impact characterization through Impact2002+

Further we compare the results after normalization from Excel to SimaPro. This helps in the validation and quality of assessment that has been carried out in this study. The only slight difference appears are in ecotoxicity i.e. 0.07 Pt with Excel and 0.15 Pt with SimaPro. This is because in SimaPro thousands of substances present were taken into account where in Excel we chose the most important one.

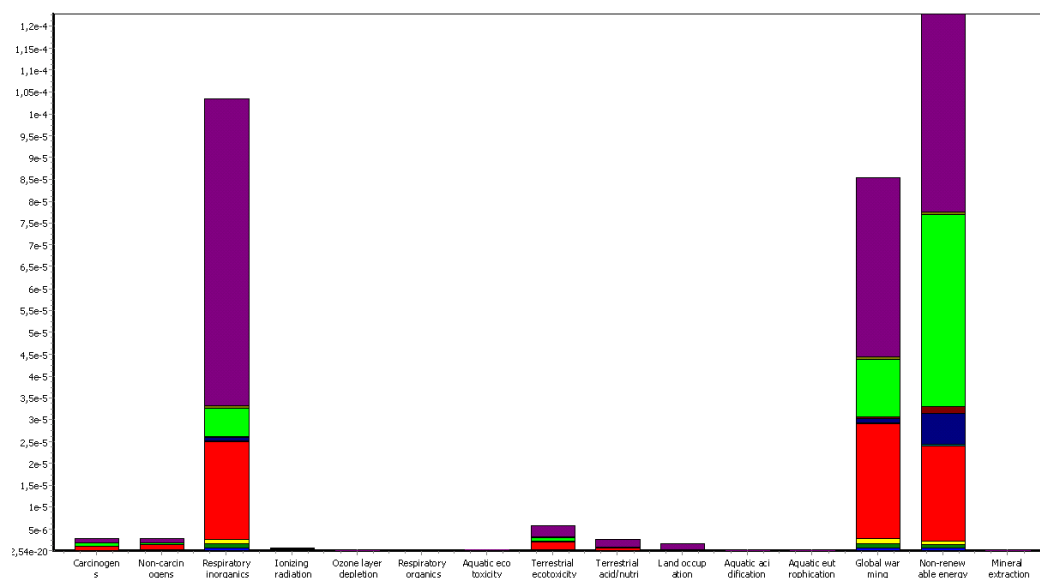

Figure 41 SimaPro Impact characterization through Impact 2002+



---

## 8. Evaluating the limits identified through LCA and proposed solution

---

As mentioned earlier LCA is an environmental assessment tool for evaluation of different impacts related to a product on environment during its entire life cycle. These days LCA has become an interesting decision making tool for promoting sustainable alternatives. Like in our case, we study Jatropha system in a systematic manner in terms of energy efficiency, environmental impacts and may be for future cost benefit. Sustainable indicators are used as a criterion for identifying and choosing the appropriate sustainable option. For the challenges of sustainable development we require a system approach, where emphasis is placed on studying and understanding the relationship between parts or a system functioning in whole in an integrated manner (Azapagic et al., 2006). In this chapter we discussed the problems associated with LCA limitations and the potential of PSE as a sought out solution of developing advanced approach.

Early LCA studies invariably analyzed inventory and identified the life stages responsible for dominant emissions or solid wastes or energy consumption. The recommendations then focused on those life stages and concerns. Many companies continue to use the LCA as an internal check of their environmental performance rather than for public information, although ISO 14044 makes it mandatory for products to be compared environmentally (Curran, 2006). Our ability to compare product and process alternatives using life cycle assessment remains limited because of the complexities of our interactions with the environment, and the nature of inventory data collected. The approaches used to derive the metrics range in their site-specificity, complexity, comprehensiveness, sophistication and uncertainty. There is evidence to support instances when it is feasible to use site-specific methodologies, and instances when it is more appropriate to compare generally, but it is often necessary to use more than one approach within a given impact category. Some of the strengths and weaknesses of existing approaches in the commonly considered categories of global warming, ozone depletion, creation, eutrophication/acidification, toxicological impacts and resource depletion are also discussed in our research work.

The ideal LCA assessment should be complete and sufficiently rigorous to be of use to industry. This is not happening today as data may not be accurate or complete and system boundaries are not easily defined. As a result, different assessment teams can produce different defensible results. Industry wants to conduct meaningful LCA in a more definitive, simple, relatively and inexpensive approach. Because there does not seem to be a single tool that gives reproducible results no matter who is the stakeholder for that, many remain keen about LCA studies. A lack of consistent, universally accepted LCA standards makes it extremely insignificant to compare results (Reinhardt et al., 2008). LCAs typically have large data gaps of various types. These gaps include the inclusion of certain unitary process that can affect the whole system and environmental relevance of data for process. It has also been propositioned that LCA investigates burdens on the environment, rather than impacts because there is as yet no universally acceptable methodology to assess impact on the environment. This may explain issue of current LCA is also struggling with how to assess multiple product-process life cycles in a more sustainable way. That's why we proposed a new product-process oriented LCA with the help of PSE-LCA coupling that can tackle the limitations of LCA and this LCA could be applied not to a single product but also could be used for other products and process in a more interacted manner.

## **8.1 PSE METHODS AND TOOLS AS A POSSIBLE SOLUTION FOR LCA LIMITATIONS**

LCA is defined as a method "to assess the environmental impacts of a product, service or process", In the recent years it has been mainly implemented in the field of environmental assessment of products with a very little integration for environmental considerations in processes of production chain and economy of services. Studies are available with state of the

art methodology and its recent improvements (Achten et al., 2010; Finnveden et al., 2009; Guinée et al., 2011; Pennington et al., 2004; Rebitzer et al., 2004; Reinhardt et al., 2008). They are also interested in the application of the methodology in specific areas such as food, biofuels, renewable energy with variations of the method such as cycle analysis of costs, process optimization, specific LCA chemical processes (Azapagic, 1999; Burgess and Brennan, 2001; Rebitzer et al., 2004). The present research aims to identify the ways to integrate the LCA in the field of process system engineering and to highlight opportunities for research in this area. It also helps to answer the following key questions:

- What are the tools and concepts that underlie the inclusion of environmental considerations in the field of PSE?
- What are the concerns of the application of LCA in the fields of design and process optimization?
- What are their characteristics and prospects of LCA and PSE coupling they generate?

Process System Engineering (PSE) is an academic and technological field related to methodologies for chemical engineering decisions. Such methodologies should be responsible for indicating how to plan, how to design, how to operate, how to control any kind of unit operation, chemical and other production process or chemical industry itself (Klatt and Marquardt, 2009; Marquardt, 1999). In this study, the computer aided process engineering method of PSE, has been used as a solution for tackling the above mentioned issues and limits to its core. This method permits to simulate the whole process, a part or a unit operation. It can also help to create or modify a simulation, so in our study, PSE permit to model and simulate the transesterification, part of our development process of the biodiesel production. We propose a systematic method of process design integrating PSE and LCA tools applied to an actual case study of *Jatropha* biodiesel production process. In this case study, process simulator and other PSE databases are utilized as data resources for LCA. Based on the case study, a procedure to perform LCA with PSE tools is discussed. The main theme is to have systematic methodology with an integrate life cycle assessment for process systems design. Which can be further applied to combined fuel and power production from biomass in multi-objective optimization framework.

## **8.2 LCA APPLICATION IN PROCESS DESIGN AND OPTIMIZATION**

Azapagic (1999) published a detailed treatment of the application of LCA to process selection, design and optimization. Since this early review, methodological aspects of LCA have been improved and the methodology is more and more accepted within the scientific community. In the beginning life cycle studies published compared product alternatives, and rarely find studies the deal with process design in the early stages of the methodology. The

starting point for the use of LCA for sustainable development has been the design of “environmentally friendly” products, and this approach was progressively extended to the process industry (Young et al., 1997). Cradle-to-grave methodology was mainly applied to products, by developing the life cycle approach which targeted the product because the process, from this point of view, is considered as a part of the product life cycle (product manufacturing). In the present decade life cycle approach and its application to process assessment has increased. Now there are literatures in small proportion available which shows the development of perception of life cycle thinking for processes. In fact, the process could also be seen with its own life cycle: design of the process (planning, design, R&D), installation, use of the process (manufacture of the product), disassembly of the process and remediation of the used lands (Jacquemin et al., 2012). Figure 42 illustrates the different LCA approaches that could be adapted and the main alternative uses of LCA to products, and LCA to processes.

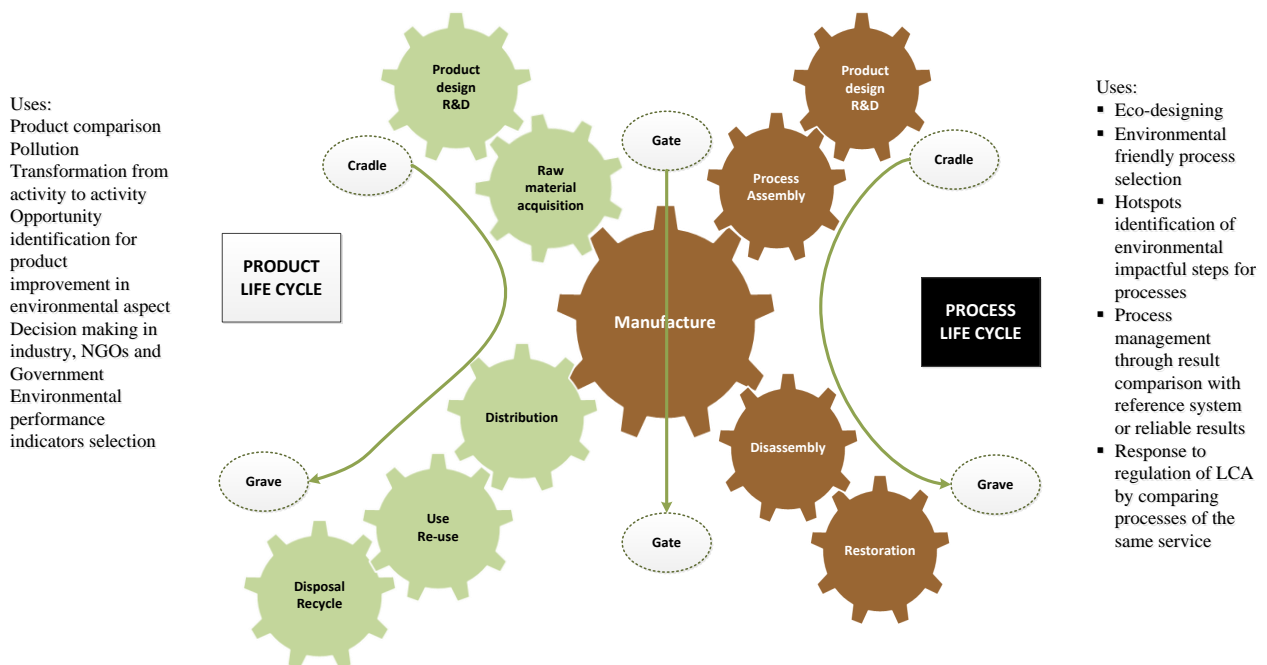

Figure 42 Integration of life cycle approaches for process design and optimization (Jacquemin et al., 2012)

LCA applied to process could be adapted to a “cradle-to-gate” approach, which means that the study stops at the gate of the factory: the manufacturing product end of life of is not considered. Another approach that has been developed is to consider the process from “gate-to-gate” mean that the system boundaries of the LCA end at the manufacture gate and do not consider the whole life cycle. This approach is rarely used but finds an application in chemical engineering process design. Thus, regarding the process industry, it was suggested that LCA could be used in various contexts as for example the use at the research and development phase of a process, in guiding process evolution; in process design for comparison and

selection of options; in business planning for identifying weak links in a processing chain or in comparing processes with those of business competitors. Therefore in the recent days, researcher and scientists are interested for the application of LCA to processes. This could foresight an efficient tool for the design and improvement of processes, by taking into account classical criteria like yield and cost concerns, and incorporating LCA driven environmental considerations. Keeping in mind the idea of this integration of LCA for process the following Figure 43 presents the global vision of framework proposed for this study. Where the central green box show the classic LCA applied to process and the dashed arrows indicates the proposal for coupling PSE with LCA. The main aim of this present theme is to propose a systematic approach for integrating LCA in process systems engineering using simulation, which strengthen the ultimate consideration of the influence of the process parameters and its integration on the thermodynamic, kinetics and environmental life cycle performance in the early stages of process synthesis and designing.

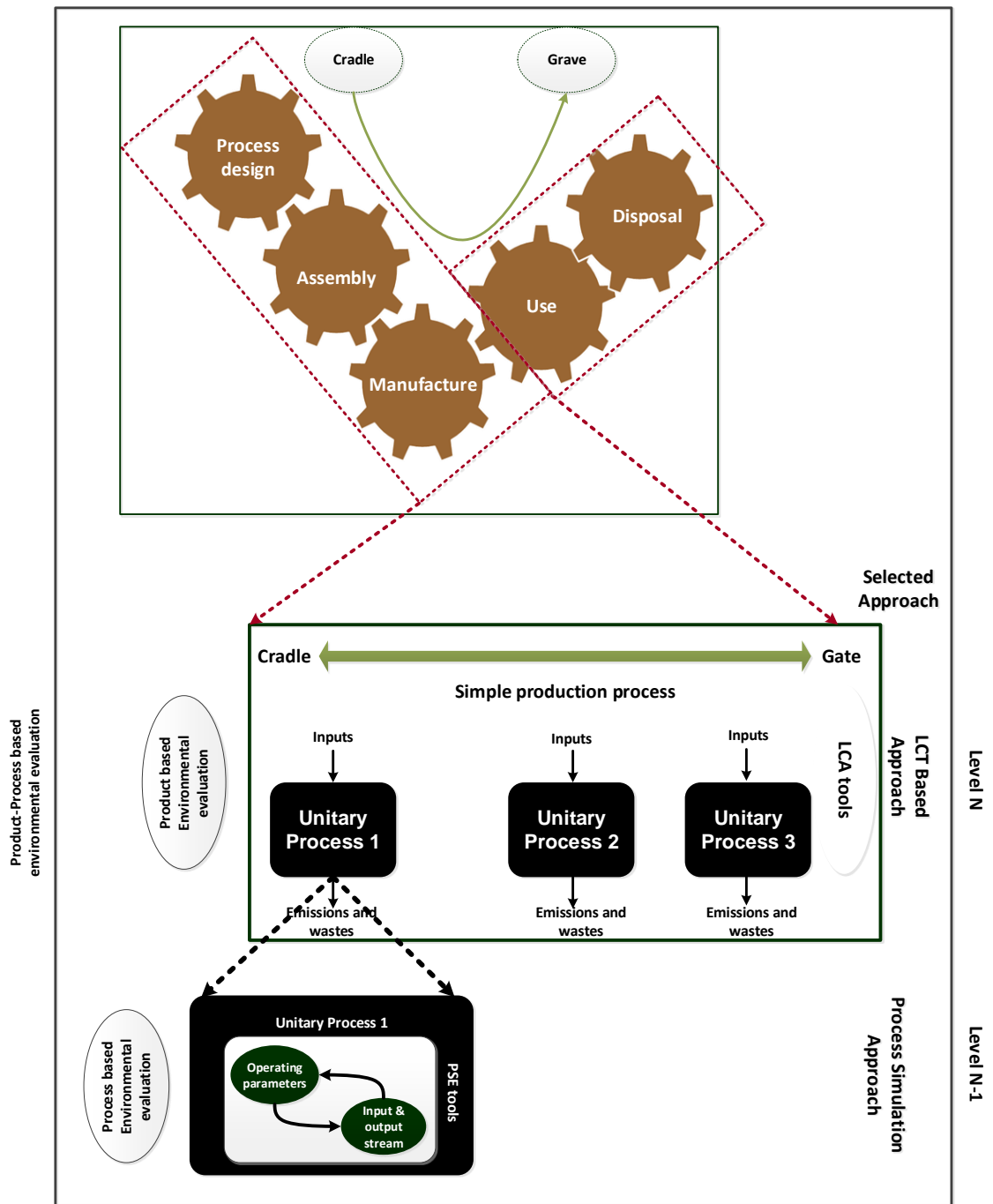

Figure 43 Global vision of proposed framework for study

---

## PART C

---

# **C. FRAMEWORK FOR A PRODUCT AND PROCESS BASED ENVIRONMENTAL EVALUATION**





---

We investigate the opportunities of PSE methods and tools and LCA method integration for analyzing the sustainability of production chain system. Especially we suggest a frame for a real product and process based environmental evaluation. An agro-chemical production constitutes multiple complex processes which require systematic process design and optimization. The main aim of re-designing these production processes is to maximize sustainability issues related in the presence of LCA. We evaluate LCA with the help of latest PSE tools used for the development of present state of LCA which is termed as SimLCA. We review the main PSE elements such as process model development and process design, simulation of agro-chemical process and its integration for environmental evaluation. This surely helps to highlight the sustainability for an assigned agro-component production system. So we start this part with the review of coupling between LCA and PSE. Next we evaluate the structure of transesterification for simulation. This includes the kinetic models, enthalpy balances for thermodynamic model, simulation of important unitary process and critical evaluation of results. Further we demonstrate the coupling and structure of SimLCA. Finally we evaluate our SimLCA tool by analyzing different scenario and assumptions.

This part is subjected to (Gillani et al., 2011a) and (Gillani et al., 2013).



---

## 9. Proposal for coupling PSE and LCA

---

This chapter starts with the review of PSE tools and PSE-LCA coupling options. We review both aspects of coupling that is PSE embedded LCA or LCA embedded PSE. Further we look forward to the proposed approach for this coupling in scientific context. The detail evaluation of proposed approach is also discussed in this chapter. Then eco-designing methods for agro chemical processes are highlighted at the end. With diagrammatic illustrations of different tasks this section helps to understand the step by step integration of PSE and LCA and the question related to this integration for society in general and scientific community in particular.

## **9.1 PROCESS SYSTEM ENGINEERING AND ITS ROLE IN ENVIRONMENTAL EVALUATION AND ECO-DESIGNING**

Process System Engineering (PSE) is an academic and technological field related to methodologies for chemical engineering decisions. Such methodologies should be responsible for indicating how to plan, how to design, how to operate, how to control any kind of unit operation, chemical and other production process or chemical industry itself (Klatt and Marquardt, 2009). The field of PSE has been rapidly developing since the 1950s reflecting the tremendous growth of the oil, gas and petrochemical industries and their increasing economical and societal impact.

The chemical process industry faces very important economic and social issues (Breslow et al., 2003). Globalization of the industry has opened new markets. While potentially this can help to increase the standard of living throughout the world, globalization has also resulted in growing worldwide competition. Furthermore, the introduction of e-commerce is producing greater market efficiencies, while at the same time greatly reducing the profit margins. Added to these challenges are increased investor demands for predictable earnings growth despite the cyclical behavior inherent in most of the chemical industry, which tends to be capital intensive. Socially, sustainability becomes even more important challenges for the process industries. Many of the raw materials used, especially those derived from oil, gas, and some plants and animals have been, and in some cases continue to be, depleted at rates either large compared to known reserves, or faster than replenishment. Process Systems Engineering (PSE) may play a significant role in meeting the challenges of achieving sustainability, but this requires an expansion of the traditional PSE boundary beyond the process and enterprise to include the life cycle and associated economic and ecological systems (Sikdar, 2003).

LCA represents a broad class of methods that consider this larger boundary, and includes methods for assessing the impact of emissions (Bare and Gloria, 2006), the reliance on fossil and other resources and the transformation of energy (Baral and Bakshi, 2010). These methods have been combined with traditional process design by treating the life cycle aspects as design objectives along with the traditional economic objectives (Azapagic et al., 2006). Our research department has already started activities on improving the link between LCA approach and PSE methods.

Further, LCA allows the process engineer to characterize the environmental impact of a chemical process. However, the study often focuses on either LCA (PSE for LCA) or PSE (LCA for PSE). In order to put into place a method granting an equal importance for both LCA and PSE, a different approach is adapted by Portha et al., (2010) who investigated a new method based on exergy. Exergy is useful to determine greenhouse gas emissions by the way of relationships depending on the system considered. Indeed, since exergy is a thermodynamic function taking into account the irreversibility of the system, hence well represents the wasted

part of the provided energy. Since this wasted energy is closely linked to the pollutant emissions, exergy is a good way to characterize the environmental impact of a process. In concrete terms, thermodynamic balance is performed on the boundaries of the process, and thanks to a process simulator and a FORTRAN subroutine taking into account the chemical transformations in the reactors; it is possible to compare two processes having the same function. One should note that this comparison, based on the co-products quality and resource depletion, is possible only with the LCA data. According to Portha et al., (2010), life cycle assessment and exergy analysis are complementary tools that can be used together. However, even if exergy calculation should be next available in process simulator (such as Prosim Plus), the exergy is hard to handle and require high level competence in thermodynamics (Goumelon et al., 2013).

LCA can serve as a useful tool for the implementation of eco-design by gathering and examining the energy and material inputs and outputs of a product system and evaluating the associated potential environmental impacts throughout its life cycle (Cerdan et al., 2009). The global view implicit in LCA makes it possible to address the environmental issues beyond the local boundaries of the product manufacturing phase. According to Cerdan et al., (2009) LCA for eco-designing can be integrated to deploy strategies such as:

- reduction of the number of different materials and selection of appropriate ones
- reduction of environmental impact in the production phase
- optimization of the distribution phase
- reduction of environmental impact in the use phase
- extension of the product's useful life span
- simplified design for disassembly
- design for reuse
- design for recycling

Cerdan et al., (2009) explore the correlation between LCIA indicators and proposed eco-design indicators. Other scientific literature such as (Johansson and Luttrupp, 2009), (Kurk and Eagan, 2008) and (Alonso et al., 2007) devoted to discuss the different viable strategies and tools for eco-design. Integrating LCA for eco-designing is related to the theme of “green products” as all the products use materials and energy, and produce wastes. LCA systematically incorporates environmental consideration for design process and eco-designing, thus the integration enables to a new idea generation for innovation. Taking life cycle approach, one can use multiple strategies in multiple life cycle phases to improve environmental performance.

### 9.1.1 *Process model for biodiesel production*

Biodiesel is the most common and most famous alternative for fossil fuel used in Europe and many parts of the world these days (Demirbas, 2007). Even though biodiesel can be derived from many types of feedstock, the production process can vary due to physical and chemical properties associated with it. These required pretreatment of transesterification for their high fatty acid ratio. So the essential properties of triglycerides for conversion and biodiesel production such as fatty acid value, saponification value and water content are important to be considered along a viable technique of biodiesel production which further induces toward sustainability aspects.

Two possible approaches used for the design of biodiesel production and integration are one with selecting a reactor and moving outward by adding a separation and recycle system. At each layer, decisions must be made at each stage according to the available information. Another approach for designing biodiesel process plant is by embedding start of all feasible process options and feasible interconnections as candidates for an optimal design structure. Essential and important features are included to ensure that all features that could be part of optimal solutions are incorporated. Subsequently, any features considered infeasible are removed from the structure (Nasir et al., 2013).

A detailed design of biodiesel plant from waste cooking oil was conducted by (Zhang et al., 2010a). The biodiesel plant performance was assessed using alkali and acid catalysts. The processes in the production were esterification, transesterification, methanol recovery, water washing and fatty acid methyl esters (FAME) purification. Similar study was performed by (Tapasvi et al., 2004) but they incorporated the mass and energy balances in the process model. Soybean oil and canola oil were compared in terms of their process outputs. The processes of crude oil degumming, refining and drying were embedded before the transesterification reaction. Results showed that Canola oil had higher process outputs than soybean oil. The model developed could be further applied in performing economic feasibility studies of biodiesel production.

Another integrated process model and product design of biodiesel production was employed by (Chang and Liu, 2010). Their study focused on the oil characterization, thermo-physical property estimation, rigorous reaction kinetics, phase equilibrium for separation and purification units, and prediction of biodiesel fuel qualities. They applied alkali-catalyzed transesterification process and predicted the reactor/separator performance, stream conditions and product qualities using various feedstocks. Another enhanced research on equilibrium phase systems for biodiesel production was conducted by (Oliveira de et al., 2009) to determine the liquid-liquid equilibrium of mixtures containing alcohols, glycerol, and fatty acid esters in the production and purification process. Study related to the integration of different equation to

determine the methanol–triolein binary system at various temperatures and pressures was provided by (Tang et al., 2007).

Studies like Zong et al., (2010) highlighted the lack of proven models and databanks for estimating thermo-physical properties of vegetable oil and blends. They attempted the use of triglycerides pure component properties for modeling the biodiesel production processes. As a result, the databank obtained managed to provide thermo-physical property for process modeling and design, simulation, and optimization of biodiesel production processes.

Design and operation of chemical plants by incorporating sustainability elements are currently desirable as it promoted minimum energy usage and wastes. Recent works showed that incorporation of sustainability elements into PSE approaches were capable of increasing profit of chemical industry. Halim and Srinivasan, (2011) dictate combinations of different PSE approaches using simulation and optimization in the development of framework for generating sustainable design and operations alternatives. These initiatives for chemical process plants focused on waste minimization in the process plant. The methods used were knowledge-based simulation-optimization framework, and integration of waste diagnosis with process simulation and mathematical optimization. Myint and El-Halwagi, (2009) conducted a process analysis and optimization of biodiesel production from soybean oil through inter-connected activities such as simulation and process design. They carried out simulation studies on various separations configuration scenarios. The aim was to determine the interaction among the compounds; and separation behavior of the compounds using different amounts of separating agents.

For sustainable biodiesel plant, Myint and El-Halwagi, (2009) had identified opportunities for process integration and cost minimization; and performed simulation with various mass and integration processes. They also conducted capital cost estimation, profitability and sensitivity analyses. Likewise, Elms and El-Halwagi, (2010) also evaluated a process design and optimization on biodiesel production and performed capital and operating cost estimation. However, they included the estimation of CO<sub>2</sub> emission in the biodiesel process design per effect of GHG policies. In short, the systematic approach for the design of biodiesel production processes per the GHG policies did provide a powerful decision-making tool for policy makers and producers.

### 9.1.2 *Process simulation for biodiesel production*

Process simulation studies offer convenient tools for determining process characteristics and their dependence on design and operating variables. Process simulations usually begin with the determination of the chemical components and selection of suitable thermodynamic model. On the other hand, unit operations, operating conditions, input conditions and plant capacity must also be specified. Most of the property data of components are available in the database library. However, registration of the component can be made by introducing the

component as a new chemical component if certain component property is unavailable in the simulator database,

Study like the one by García et al., (2010) performed a simulation to predict normalized biodiesel properties using different feedstock. They compared the results with previous experimental data in terms of thermodynamic packages used earlier. They found that the predictive model was mostly well-suited to experimental data. In contrast to García et al., (2010); Zhang et al., (2003) conducted simulation of biodiesel plant from waste cooking oil using different types of catalysts. They used alkali catalyst for transesterification as well as acid-catalyzed transesterification of biodiesel. Designs of biodiesel plants were carried out and simulated using available thermodynamic models. The simulation showed that for an alkali-transesterification process using pure oil to produce biodiesel, the right amount of water could lead to near complete separation between the FAME and glycerol phase. Acid as catalyst for transesterification reaction conducted by Zhang et al., (2003) applied higher reaction temperature, pressure, and higher methanol to oil molar ratio than alkali-catalyzed transesterification.

There are other studies, like the one related to a process simulation was also carried out by Sotoft et al., (2010) for biodiesel production using enzymes as the catalyst. In their study, Sotoft et al., (2010) utilized the Aspen Plus simulator. The findings showed promising yield of solvent free enzyme biodiesel production. In contrast to this study, Kaewcharoensombat et al., (2011) performed process simulations of biodiesel from various feedstocks. They used waste cooking oil, rapeseed oil and Jatropha oil as feedstock through alkali catalyst for transesterification reaction. They could obtain high purity biodiesel when the process is simulated using Aspen Plus.

Nevertheless, all the simulations carried out within the specified operating conditions have proven that all process flow diagrams are capable of producing high quality biodiesel within the specified operating conditions. However, each process has a number of limitations. For example, both the alkali catalyzed transesterification using virgin oil and the enzyme catalyzed transesterification requires costly raw material or expensive enzymes. On the other hand, the supercritical alcohol process requires high-pressure reactors and large amounts of energy to separate the methanol from the feed stream, thus increasing the total costs. Simulation studies are usually accompanied respective impact on the environment and economic viability through cost benefit analysis.

### 9.1.3 *Process optimization for biodiesel production*

In the recent era, optimization in PSE also concerns the environmental issues in the synthesis and planning of chemical process along with economic issues. Process optimization for biodiesel production is important to determine the values of essential variables for the



achievement of highest performance criteria. In plant operations, benefits arise from improved performance, reduction in energy consumptions, reduction in maintenance cost and efficient utilization of staff. To gain the benefits, critical analysis of the process and design, accomplishment of certain targets, and use of experience is importantly required. A systematic methodology was introduced by Guillén-Gosálbez and Grossmann, (2010) on how to achieve optimal environmental conditions and maximize the profit. Generally, the techniques can be observed under three sections; process synthesis, supply chain management, and impact assessment method. In process synthesis, alternatives of process are first listed, followed by selecting the optimum processes.

Optimization often concerns minimization of cost and maximization of economic potential known as objective function. For example, heat integration and cost of the heat exchanger network and utilities have significant influence on the optimum conversion. Also, the sequence of multiple separators used in a process system can influence the reactor conversion. At the design stage, optimization process depends on the variables involved in the process itself. An optimization study on process synthesis was conducted by Di Nicola et al., (2010) using modeling and multi-objective genetic algorithm optimization in biodiesel production processes. This study determines the configuration of main parameters to obtain maximum purity of some important compounds, and also the evaluation for minimizing the energy requirements in the process. On the other hand the research work Halim and Srinivasan, (2011) stressed on optimization of acid catalyzed process using waste canola oil for minimizing the waste of biodiesel synthesis, and maximizing the profit. The methods were proven to enhance both the impact and profit of glycerol as a waste by-product.

Leão et al., (2011) optimized the structure for supplying oil to biodiesel plant by developing mathematical programming and identifying optimal conditions using computer simulation. The unitary processes considered were production, transportation and pressing of oil seeds and transportation of oil to the biodiesel plant. Supply chain management Optimization is often performed to find optimal investment solutions for production processes. For biodiesel production, Supply chain management is conducted at earlier stage of production process through the analysis of conditions required to fulfill the demand of oil feedstock for biodiesel plant. On the other hand, Leduc et al., (2009) structured the optimization study to find optimal location for *Jatropha* biodiesel plant. Similarly, mathematical programming was conducted and analysis was carried out by using various feedstocks. In addition to that, Srinivasan and Malliga, (2010) provided optimization of *Jatropha* seed yielded through a cultivable waste land. The optimization was done through corporate fuzzy inference system which involved the factors that influenced the *Jatropha* yield (such as irrigation, fertilizer usage, rainfall, temperature, acidity and altitude). The most interesting aspect of performing optimization in supply chain management is that it serves as a strategy for customer satisfaction starting from raw material the end-consumer.

## 9.2 THE PSE AND LCA COUPLING

For a long time, the sizing of a chemical process has been focused on a unique criterion: the profitability. How to size the different operation units so that the global process is optimized economically speaking was the work of the process engineer. However, with the rise of global warming problems due to the increase of the anthropogenic emission of greenhouse gas and more generally with growing importance granted to sustainable development, process system engineering has turned into a complex multi-criteria optimization problem (Azapagic, 1999). Indeed, the process engineer has now to take into account not only the profitability of the process, but also its environmental and societal impacts.

To do so, many approaches have been studied: environmental impact assessment, best practicable environmental option assessment, environmental impact indices, environmental risk assessment, cost-benefit analysis and life cycle assessment. Among these approaches, the coupling of PSE and LCA is investigated here because it is thought to be the best instrument to improve the environmental performance of a process. The coupling can be of different nature depending on the focus of the study. Either the study is focused on PSE with an associated LCA study (LCA for PSE), or a LCA study including mass balance and thermal balance (PSE for LCA).

### 9.2.1 PSE embedded LCA

The aim here is to find a way to support process design systems for making environmental decisions. LCA is an interesting mean because of it offers the possibility to compare the environmental merits of different alternatives. Indeed, even if LCA was initially developed to compare the environmental burdens of different products, it can also be applied to process steps. One should note that even applied in processes, the purpose and the intended audience of the LCA study have to be clearly defined (Burgess and Brennan, 2001). The idea is to develop a framework including process design for LCA study in hand.

A first approach is the integration of LCA methodology in early phase process design as shown in the Figure 44. Indeed, since a given product can most often be synthesized by different ways, it is important to compare the different existing alternative processes. Investigating not only the conventional process but also the relevant supply chain in order to fully cover the life cycle of the process, hot spots for whole production system are identified in their approach using a dominance analysis so that the best process can be determined. For this purpose, Gasafi et al., (2003) have developed a method beginning with a two-step selection: a divergent step consisting on the generation of the different alternatives and a convergent step where all the listed alternatives are analyzed and evaluated in order to determine a "short list" composed by the most promising ones. Then, for these selected processes, LCA is applied to all the identified hot spots of the process. This combination of LCA and dominance analysis is

then iterated. After identification of the hot spots, the designer can create alternative designs that are more environment friendly, and then do the LCA/dominance analysis again. One should note that in this approach, weighting factors to aggregate the data are not taken into consideration because of the unreliability of an early phase design data and because weighting factors are often linked to political and ethical point of views, which are negligible in preliminary design.

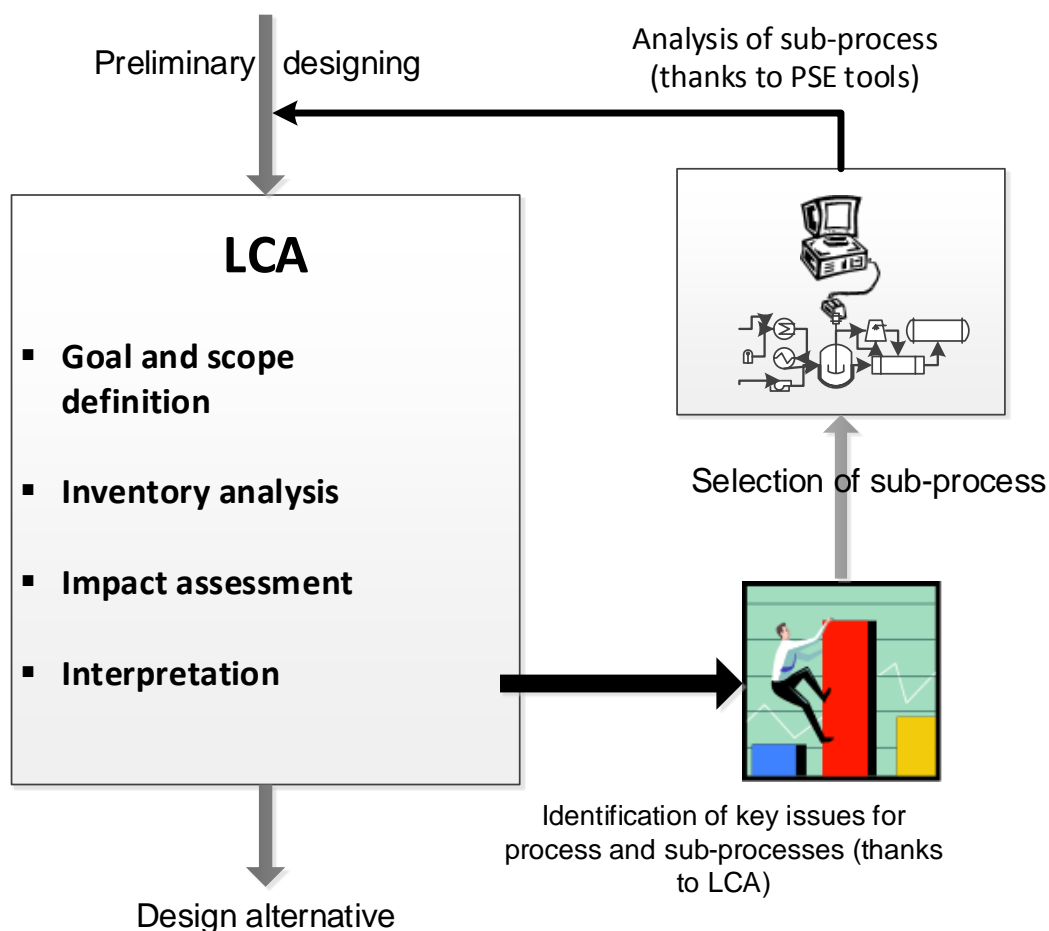

Figure 44 Idea of PSE embedded LCA

Early phase focused on LCA-PSE coupling has also been investigated by Hirao et al., (2008). However, the framework is here composed of four stages (Process Chemistry 1, Process Chemistry 2, Conceptual Design 1 and Conceptual Design 2) dedicated to the process design and integrates a multi-objective optimization (economic performance, life-cycle, gate-environmental impact and Environment-Health-Safety hazard). The approach adapted in this framework consists of multiple stages. At each stage, reaction routes and process technologies are studied and evaluated through the previous criteria and the most promising of them survive to the next stage (Hirao et al., 2008). The main difference between these two approaches is the

fact that in the first method, the process is optimized unit per unit whereas the second method optimizes the whole process starting from a simplified process going to a more complex one.

Another approach is to integrate LCA principles and mixed-integer nonlinear programming in order to lead to a multi-objective problem in which economic and environmental criteria is optimized (Guillen-Gosalbez et al., 2008). By solving mixed-integer nonlinear programming problem with usual multi-objective optimization tools, the designer can select the optimal flowsheet structure.

### 9.2.2 LCA embedded PSE

Life cycle analysis is performed on systems on which we know all the materials and energy necessary to build a specific product. For instance, in photovoltaic domain, the functional unit is often a power delivered by the panel and the LCA is calculated in knowing the materials having been used. In chemical production, the chemical engineer use models to predict the quantity of products and sub products in the output of the system. The equations are complex. The calculus of the need of energy depends of the thermodynamics of the reaction/separation.

However, LCA is a multidisciplinary tool able to estimate numerous environmental impacts including global warming and inherent safety hazard indicator. These impacts are important when a chemical plant must be design: what synthesis routes, what process technologies and why?

The idea is to insert the LCA methods and tools into PSE methodology again for strengthening the sustainability options for a production chain system in particularly emphasis on the need of energy and the quantification of hazardous sub products. The Figure 45 here demonstrates the idea from research work of Kniel et al., (1996) for integrating LCA applied to process design.

Nguyena et al., (2010) propose to compare different synthesis routes to product ethyl acetate from bio-ethanol. Firstly, four routes are presented then the process simulator ASPEN PLUS is used to design and model the processes in function of the route. Secondly, three indicators are created in order to know the economic and environmental impacts: production cost indicator, global warming impact indicator and inherent safety hazard indicator. The LCA tool allows discussing about results presented via three graphs showing the impact of each routes. Their study demonstrates that some bio-ethanol based processes are more profitable and more eco-friendly than the traditional petrochemical process.

Abiola et al., (2010) also used this methodology to compare different process technologies. A PSE resolution (GAMS/LindoGlobal software) used the LCA methodology. Into the process of corn ethanol production, different technologies of reactors and separation units were compared: continuous fermentation versus batch one and distillation-molecular sieve

dehydration versus distillation-pre-evaporation. The combinations are multiple, that's the reason why an optimization multi-criterion was used to obtain the front Pareto. From this Pareto, the engineer will choice between optimal land area criteria, optimal total cost criteria or optimal global warming potential criteria or a mix of these criteria, then decide of the best technology to use. Both examples show how the process model tools can be performed to refine some life cycle analysis. The LCA is at the service of PSE because these methods are used into the PSE methodology for a new framework.

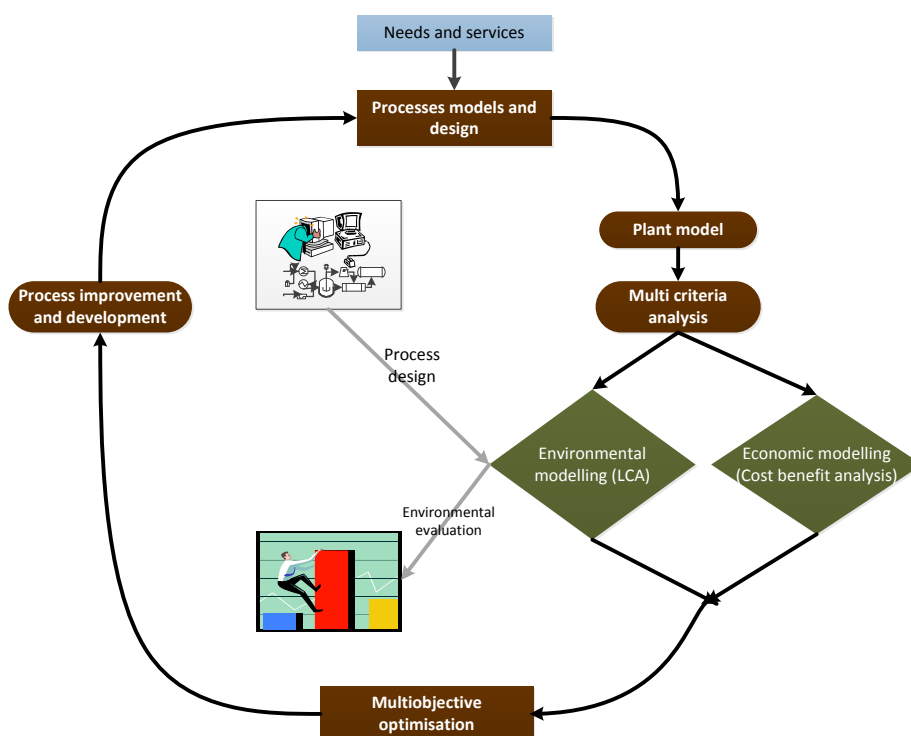

Figure 45 LCA embedded PSE idea (adapted from Kniel et al., 1996)

## 9.3 PROPOSAL FOR THE PRESENT WORK

### 9.3.1 Decision making process by environmental evaluation

Present study proposed a new idea of process integration for development of LCA present methodology in the light of process system engineering methods and tools. The current environmental and economic issues multiply the number of constraints on chemical processes up to a point where the development of each unitary process becomes equally important to coup with the huge challenge of sustainability. A way of enlarging the possibilities is to consider each chemical process for its further integration in environmental criterion. Here the proposition is an innovative PSE embedded LCA method adapted to a chemical process of transesterification in the given case study. We investigate a process design of non-agro food production system from an environmental impact point of view.

LCA has become an important decision-making tool for promoting biofuels because it is very important to study the biofuel life cycle systematically in terms of energy efficiency, environmental impacts and cost benefits. The main goal with decision making for sustainable development is to identify and choose the most sustainable option among different alternatives (Azapagic and Perdan, 2005). Our current proposal involves number of stakeholders with multiple and often conflicting objectives. We try to provide a multiple criteria decision support framework which helps to provide a systematic and step by step guidance to decision making for decision makers. This framework is carried out in accordance to the idea provided by (Azapagic and Perdan, 2005).

For our proposed framework these three inter linked steps are i.e. system for production, supply chain view and process design view as shown in the Figure 46. We identified 5 types of actors involved in the decision making process. The first one is system engineer whose job is to define the problem, identification of sustainability criteria, decision regarding sustainability indicators and implementation or non-implementation of improvement options from start to end of production. Next is the environment engineer who makes decision regarding the supply chain then propose a model for environmental evaluation, compare and evaluate alternative and sensitivity and uncertainty analysis. They also prepare and provide a documented version of environment based production process overview. The third actor in this decision making process is process engineers who often take a process with input option truly defined and clear to the core. Then they opt for certain parameters and model the whole process for further implementation and sustainable alternatives. Evaluation of results is then to be carried out in order to validate the new outcomes as data generation. They provide this evaluated process for re-integration and decision making option to environment engineers. Then there are Project manager and supply chain engineer as well. The project managers are responsible for organizing and look after the whole project and supply engineer is deals with the route of production from where they process through in this whole phenomena. This whole decision making process is a systematic advancement for sustainability option where we start from a production system proceeds toward a business and at the third level evaluate and model a chemical process as an option (Figure 46).

Once all these actors are identified and engaged in the decision making process, their first task is to identify and understand the problem at hand. In our case it may intuitively be obvious that decision makers is already be familiar with the decision problems but that is not the case most often. Depending on a particular case (for single or multiple decision makers) may have an idea of what they have to achieve but are not clear of the scope of problem and constrains. In our idea the interaction between different stakeholders is useful in the generation of ideas and to understand each other position at the outset. As mentioned the LCA point of view and in the context of sustainable development, system boundaries should be drawn from cradle to grave, cradle to gate or gate to gate. In our case, we have opted for a cradle to gate

scenario where we take the biodiesel production system, its supply chain evaluation and further modeling of most impactful unitary process. Same options are taken systematically i.e. moving from production system towards chemical process (from whole production system to transesterification modeling and simulation). This systematic evaluation includes the start-stop of production, documentation for environmental evaluation (classic LCA), modeling of unitary process (transesterification simulation) and re-integration of unitary process in the classic LCA (simulated LCA).

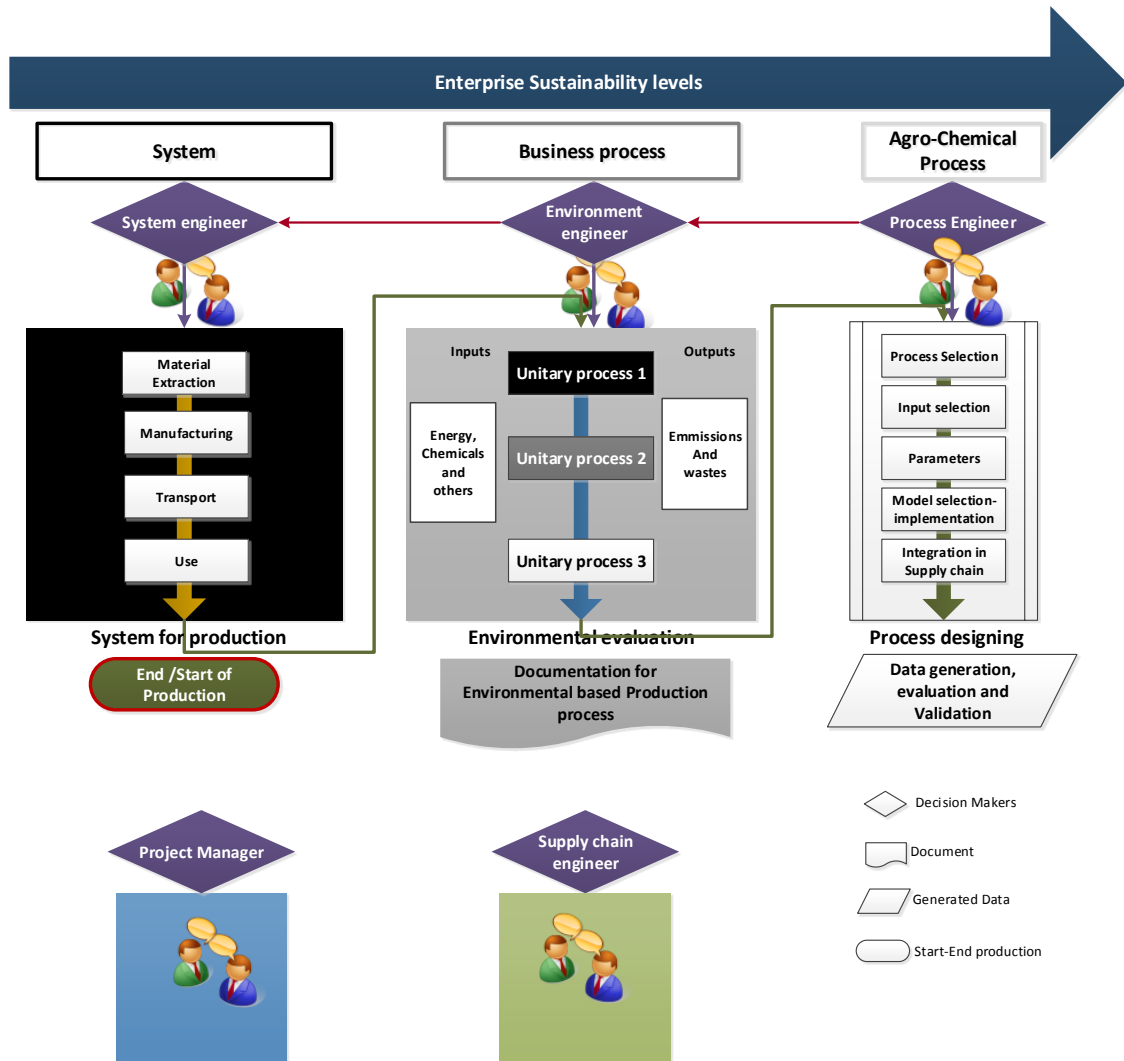

Figure 46 Decision process for environmental evaluation

Increasing importance of renewable resources leads to a change in the structure of industrial processes, leading to smaller, more decentralized processes that are shaped by raw materials used, technologies employed and products generated by their spatial context. An increase in the share of energy technologies using intermittent and/or cyclically available renewable resources such as wind and solar radiation leads to more interaction between

industry and the energy system. Industrial processes become part of regionally defined technology systems. Ecological evaluation of industrial processes has to expand as a consequence of these changes. It becomes integral part of chemical engineering design practice as systemic environmental concerns become more prevalent. It also evolves from dealing with life cycles to broadening its scope to whole technology systems. The contribution provides a framework for the requirements to be met by environmental evaluation methods that meet these future engineering challenges.

### 9.3.2 *Description of activities*

This represents how the different phases are implemented for the proposed activity for specific result orientation. The sequence of activity presented in Business Process Model and Notation (BPMN) only shows the interaction with three actors (Figure 47).

The activity diagram proposes three actors in different possession: supply chain engineer, process engineer and environment engineer. It represents the general approach that leads to the modeling of whole system in order to limit its impact on the environment. Each stakeholder performs a sequence of independent operations. The links between actors exist only through the exchange of information they possessed. However, it is basically the environment engineer who is responsible for knowledge of modeling with the aim to minimize the impact on the environment and activity of system modeling. Then the process engineer has a goal to model the given process. He has all the knowledge related to the process functions i.e. the knowledge of thermochemical reactions that take place and for the input and output (material and energy) required to achieve the desired products. He also knows the physical-chemical parameters and their relationship with the laws of transformation of inputs into outputs. Finally, he is able to simulate the process to calculate the mass and enthalpy balances (Figure 47).

The supply chain engineer knows all the information related to its suppliers, their location and the price they offer. From the list and quantities of inputs provided by the process engineer, he is able to determine the source of respective inputs. He is also capable to set different providers rivalry in order to get the best possible price. From a broader perspective, the environment engineer needs information possessed by process engineers and supply chain engineers respectively. He is capable to interpret the data flow of matter and energy as well as some qualitative information in terms of impacts on the environment. He has also the expertise to highlight the points in life cycle that have the greatest impact on the environment and propose alternatives to engineers with whom he works. Based on their knowledge they are able at the end to study the relevant proposals assigned by environment engineering. Thus it provides a loop of retro-action between three phases/layers of different engineering domains. This loop by nature suggests a number of relevant iteration for techno-environmental optimizations, where the environment engineer is assigned as head/pilot of the whole framework as he does the



interface and eases the interaction between system and process of product delivery. Supply chain engineer and process engineers at the same time:

- Validate the data used by the environment engineer from their expertise and simulation results.
- Generate data that the environment engineer cannot obtain.

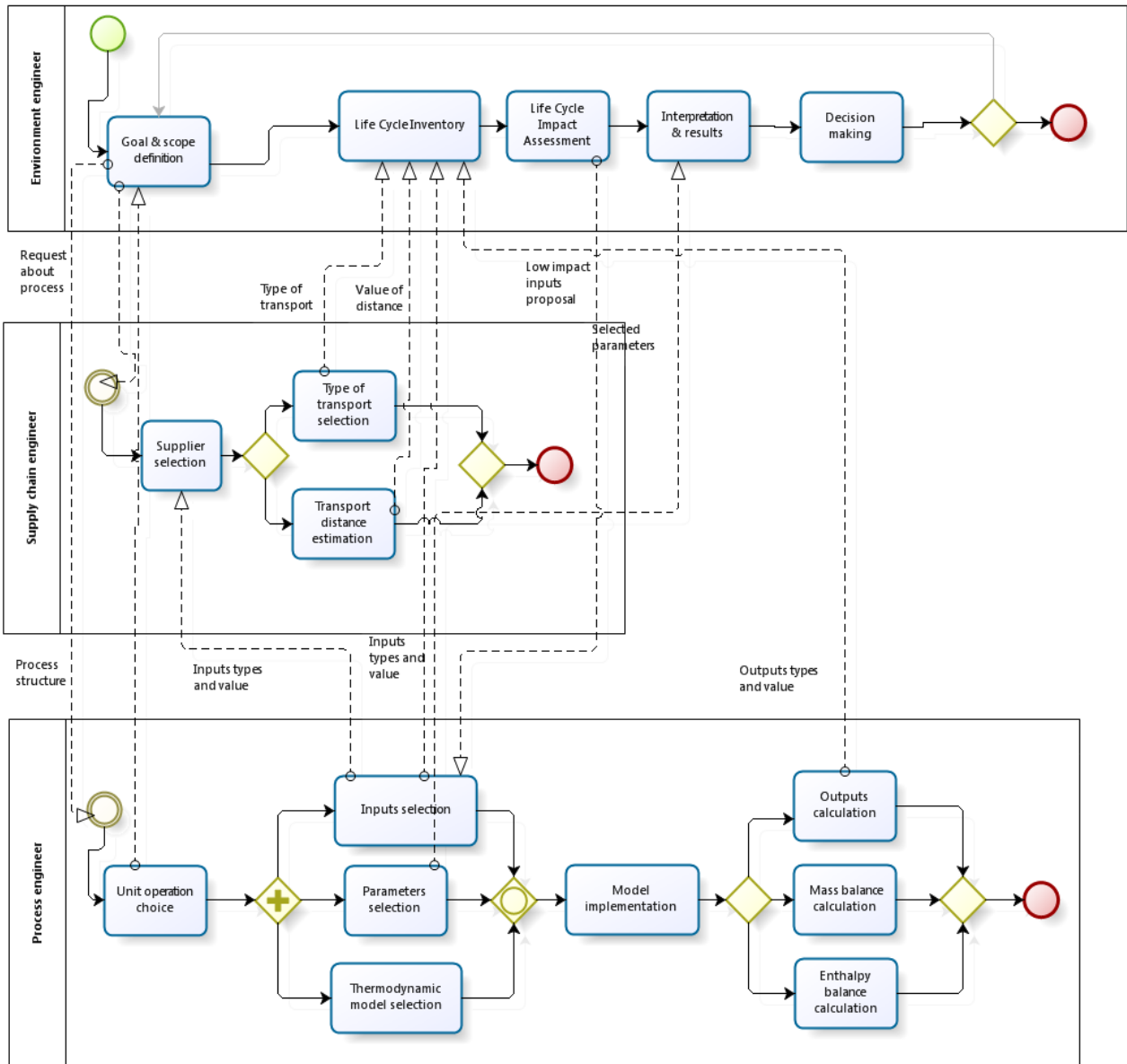

Figure 47 BPMN diagram giving an overview of interactions

### 9.3.3 Typology of messages

To define the properties of different exchanged messages in the current framework for process evaluation, process engineer uses the following basic structure (Figure 48) with respective entities (shown as UML class diagram).

The class diagram represents the information flow between the different layers of engineering model described above (Figure 47). This information conveyed by the media which comprise a message exchanger (relationship of composition between the “Message” class, “Information” and “Support” classes). A message can have one or more information linked to it. The “Information” class is the superclass of “Data” and “Meaning” class. The information class may consist of one or more set of data. Next the “Support” class is the superclass of “material” and “Informatics” class because the information from here on can be carried in the form of a tangible document or as an electronic document where document is always define as a mean of information medium.

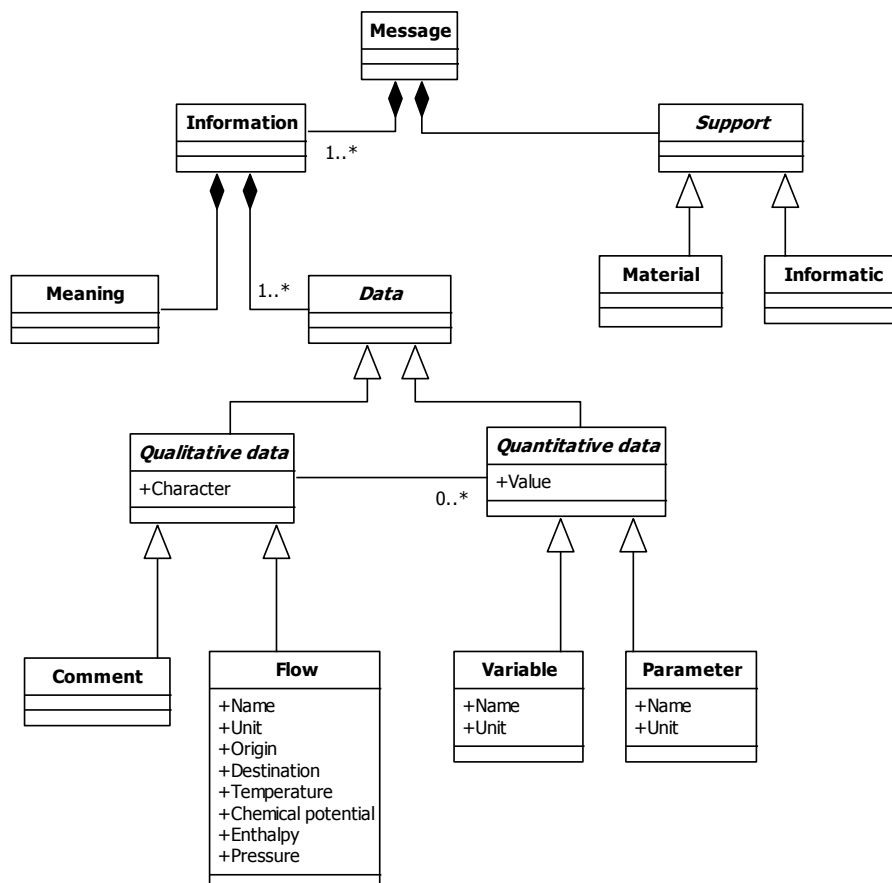

Figure 48 Class diagram used to represent information model

Further downstream in this hierarchy for the class “data” there are the subclasses such as “Qualitative data” and “Quantitative data” classes which themselves serves as super class to

the subclasses of “Comment”, “Flow”, “Variable” and “Parameter”. The “Comment” and “Flow” classes are the subclasses of the “Qualitative data” class while in contrast; the “Variable” and “Parameter” are subclasses of “Quantitative data” class. The “Qualitative data” and “Quantitative data” classes are associated in between. One element of the “Qualitative data” class can be associated with zero or more elements to that of the “Quantitative data” class. We proposed the required framework with the model given in Figure 48, where the domain entities required by chemical engineers with demanded priorities are used.



---

## 10. Simulation of transesterification unitary process for PSE embedded LCA

---

In this chapter, we mainly discussed the approach presented for this study. This approach deals with PSE embedded LCA which needs for the study of transesterification by highlighting its chemical and physical properties, inputs outputs, mass and enthalpy balances and detail thermodynamic model illustration. The descriptions of transesterification are further presented in the appendixes 15.3 at the end manuscript. The main goal of this transesterification study is to provide a process simulator which is then be integrated in the present framework in order to get a product-process oriented LCA. Tools dedicated to PSE embedded LCA is also discussed.

## 10.1 SUMMARY OF THE PROPOSED TASK

One of the main tasks is the implementation of an Excel file which simulates the transesterification process of *Jatropha curcas* oil. The main goal of this process simulator is to link it with another Microsoft Excel file created earlier that deals with the Life cycle assessment (LCA) of the global production process. At first, to create the simulator, we study and collect information about the mentioned process in the literature which correlates to the present methodology and research work.

Secondly, it is decided to consider the process flowsheet to focus on the hypothesis of work and global calculations. Then, with the completion of this task we concentrate on the structure of the Excel file to make it as user-friendly and efficient as possible because all the main calculations were completed. That is why it was decided to create one main sheet (User interface) in which an exterior user is able to change all the parameters of the process he wants before running the simulator. Further a second sheet (Flowsheet) was creating in which there is the global mass and enthalpy balance of the process containing all the equipment (reactors, sedimentation tanks, distillation columns etc...). Finally, the excepted data sheet with the molar mass of all the components and other sheets are individually devoted for the calculations of specified equipment.

To represent the behavior of these equipments Simulis thermodynamic component is used allowing physical properties and equilibrium data on the chemical products of the given process. The thermodynamic model for the equilibrium concerning all the specific equipment is the modified UNIFAC (Dortmund) 1993 model (Gmehling et al., 1993). This model is chosen because it takes in consideration all the functional groups of the chemical components in the calculations of the equilibriums.

A modeling tool on Microsoft Excel is developed to link LCA and process simulation of a transesterification unit. Before it, the life cycle is implemented in SimaPro software to help us to develop the Excel tool. The last step before linking process simulator and LCA simulator is to compare LCA simulator on Microsoft Excel and SimaPro. Figure 49 shows the idea of integrating these entire tasks for a single framework presented in chapter 11.

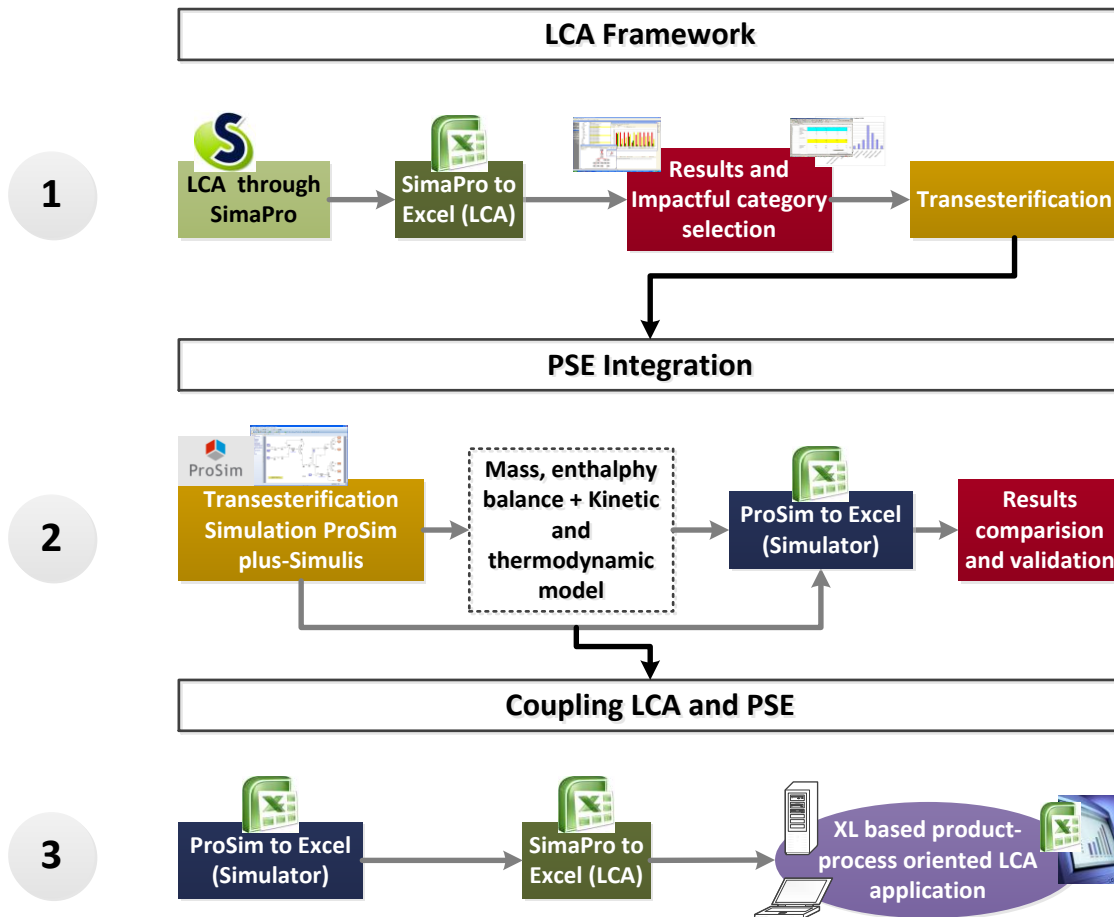

Figure 49 Tasks for transesterification simulation and coupling

## 10.2 DESCRIPTION OF JATROPHA TRANSESTERIFICATION PROCESS

Transesterification is a catalytic reaction that allows producing biofuel (and glycerol as a byproduct) from Jatropha oil and alcohol. During the transesterification reaction, the ester exchanges the alkyl from the ( $-\text{COO-R}$ ) group with alcohol, thus producing a new methyl ester. Pure plant oils are mainly composed of triglycerides (resulting from the glycerol alcohols functions esterification by three fat acid molecules). When the triglycerides react with alcohol (usually methanol), the three fatty acid strings come apart from the glycerol skeleton to settle down on the alcohol, thus producing an oil ester (the biofuel for instance, hereafter noted FAME: Fatty Acid Methyl Esters or JME: Jatropha methyl ester). (Section 4.2.1 chapter 4 and 15.3 of appendixes for detail equation and description)

This reaction can be catalyzed by an alkaline, acid or enzymatic catalyst. Only the first is illustrated in this example. The main characteristics of processes that imply an alkaline catalyst are:

- Alcohol-oil molar ratio of 6 to 1
- The conversion ratio of oil into methyl ester is 90% to 98% in about 1h30.

- The process is highly sensitive to the reactants purity: the presence of water into the reaction medium can lead to saponification (fat acids react with the alkaline catalyst to produce soap and water). This saponification not only leads to a catalyst deficiency, but the soap also takes part in emulsions formation, which generate difficulties to separate and purify biofuel.
- The use of hydride reactants is particularly important and is limiting for processes using waste vegetable oils.

The process presented here is using pure vegetable oils from *Jatropha carcus* as raw material. This process involves reactors, distillation columns, extraction columns and components splitters.

### 10.2.1 *Simulation for unitary process of transesterification*

Rigorous process simulation is today increasingly used to design and optimize biofuel production processes. It also provides a starting point for advanced simulation of such process by presenting a set of unit operation modules and components with their physical properties. In general, simulation software like Prosim Plus enables pre-size equipment, run troubleshooting and debottlenecking analysis. Their ability to run many scenarios allows solving these types of problems within a reduced time and a minimum investment.

In this phase of our research study the task in hand is to develop a process simulator for transesterification of *Jatropha* biofuel in Microsoft Excel and Prosim Plus. The threefold aim of this work involves modeling the behavior of batch process through simple use of simulator in user friendly interface software (Microsoft Excel) and also specialized software for this simulation such as Prosim Plus. Once the development of this simulator it is possible to compare and evaluate further. In addition, this tool is integrated and coupled (next chapter) with another Excel file to have a complete life cycle assessment for entire production system of *Jatropha* biodiesel.

First of all, the description of the batch process studied is presented. Then, we describe the set of hypothesis that have been drawn to make the simulator. The overall approach used to implement the Excel file is displayed next. Furthermore the critical analyses of the results in Excel are carried out. Next to this we discuss assumptions to make the file Prosim Plus. Finally, in last section a comparison with Excel and a critical analysis of results obtained different results obtained through Prosim Plus is performed.

### 10.2.2 *Selected process description*

The classic processes are those in which the presence of a catalyst is necessary. As said before, the catalyst can be in a heterogeneous or a homogeneous layer. Moreover, the process



can be either a batch process or a continuous one. Hence, the process used to conduct a transesterification is batch process shown in Figure 50 for simulation of Jatropha biofuel.

IFP has done extension in R&D work in the transesterification field with the aim of creating a product that would be suitable as an excellent substitute for diesel fuel. As a result, a new process called ESTERFIP was developed that allows the elimination of certain impurities from the product. Other details related to ESTERFIP are given in the appendixes 15.3.7.1 of manuscript.

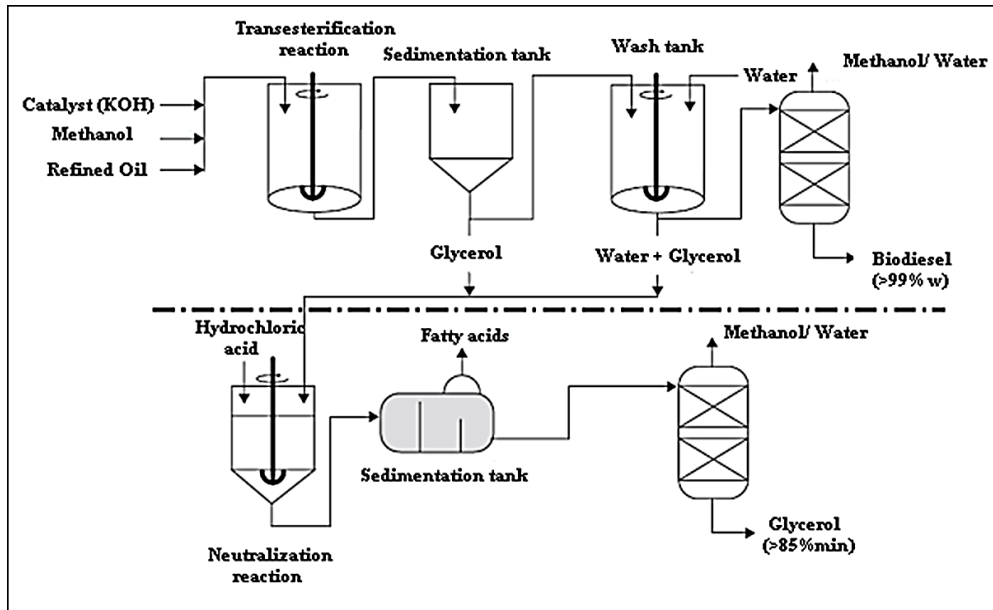

Figure 50 Diagram for modeling a batch process of transesterification (Ballerini, 2006)

### 10.2.3 Classic transesterification reaction

In this reaction the refined oil is introduced as an input that undergoes a transesterification reaction with the addition of methanol to form biodiesel as given below (Figure 51):

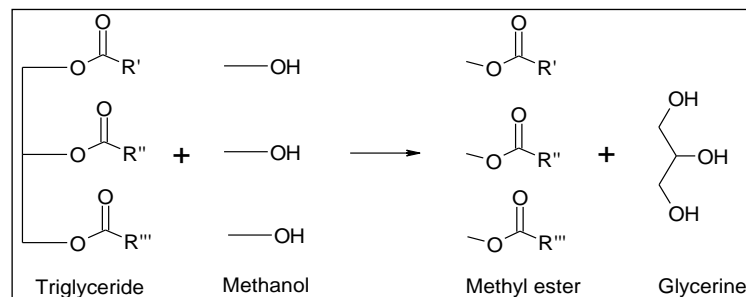

Figure 51 Transesterification reaction

In parallel to this main reaction there is a reaction of saponification of triglycerides with the help of catalyst takes place in order to form soap and glycerin given as under (Figure 52):

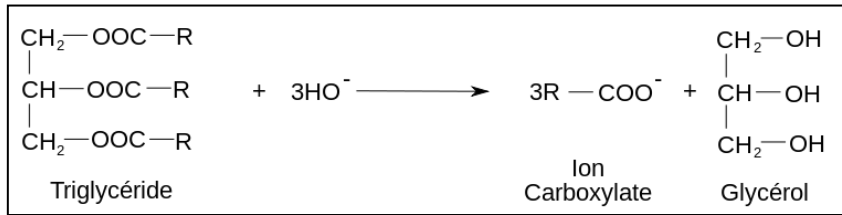

Figure 52 Saponification reaction

#### 10.2.4 Process components

Different components taken into consideration are taken from Prosim Plus database which are listed in the Table 14:

Table 14 Components with their chemical formulas, reference and respective processes

Component	Chemical formula	Reference in ProSim	Use in process
Triglyceride (Triolein)	C <sub>57</sub> H <sub>104</sub> O <sub>6</sub>	122-32-7	Raw material, main reactant
Methanol	CH <sub>3</sub> OH	67-56-1	Reactant
Methyl Oleate	C <sub>19</sub> H <sub>36</sub> O <sub>2</sub>	112-62-9	Main product (FAME)
Glycerol	C <sub>3</sub> H <sub>8</sub> O <sub>3</sub>	56-81-5	Secondary Product
Water	H <sub>2</sub> O	7732-18-5	Allow separating FAME from other product
Potassium Hydroxide	KOH	1310-58-3	Alkaline catalyst
Potassium Chloride	KCl	7447-40-7	Product coming from KOH Neutralization
Hydrogen Chloride	HCl	7647-01-0	Acid catalyst
Potassium Oleate	C <sub>18</sub> H <sub>33</sub> KO <sub>2</sub>	143-18-0	Allows neutralization HCl
Oleic acid	C <sub>18</sub> H <sub>34</sub> O <sub>2</sub>	112-80-1	Impurities in Jatropha oils

##### ➤ Jatropha curcas oil:

- Jatropha curcas oil for transesterification is supposed to be the one obtained after refining which is a mixture of triglycerides.
- The chemical compound chosen to represent the thermodynamic behavior of the mixture of triglycerides is Triolein (triglyceride present in majority in the rapeseed oil).
- The molar mass of the mixture of triglyceride was calculated using a publication giving the composition of Jatropha curcas oil from (Liu et al., 2011) Indonesia.

##### ➤ Biodiesel:

- The chemical compound chosen to represent the thermodynamic behavior of the mixture of the methyl ester is methyl oleate.

- The molar mass of biodiesel was calculated in order to balance the mass balance in the equation of transesterification for triglycerides of *Jatropha curcas* oil previously considered.
- **Free fatty acids :**
- The compound chosen to represent the thermodynamic behavior of the mixture of free fatty acids is oleic acid.
- **Soap:**
- The compound chosen to represent the thermodynamic behavior of soap is potassium oleate.

#### 10.2.5 *Different section of given apparatus*

Apparatus and equipments used are presented in this section (Appendixes 15.4.1). It is to be noted that this particular model is not intended to be used in equipment detailed design, manufacturing or even producing engineering documents without further review by a process engineer.

#### 10.2.6 *Thermodynamic model and kinetics of transesterification*

From those two considerations, a heterogeneous approach is retained. The equilibrium data for the binary systems not being available, a predictive model, based on group contribution, the Dortmund modified version of UNIFAC model was selected. More about the thermodynamic model and kinetic model are then discussed in detail in the appendixes 15.4 and 15.5 respectively along with the critical result analysis in 15.5.3.

### 10.3 **GLOBAL APPROACH FOR EXCEL SIMULATOR**

This section presents the Microsoft Excel file to simulate the process of transesterification of *Jatropha curcas*. The aim of this simulator is to provide a complete energy and mass balance of the process.

The general idea was to structure an Excel workbook keeping in mind each sheet in the workbook as an object which interacts with other sheets. Thus, we decided to create a master page named user "user interface" which appears in all the data relevant to the user process. This page is directly interacting with the other sheets in the workbook and serves as master. All other sheets in the workbook are composed of overall process flowsheet and also a sheet per process. There is also a final worksheet containing the data needed for calculations. Here is screen shot of the user interface page and apparatus for our process simulator (Figure 53):

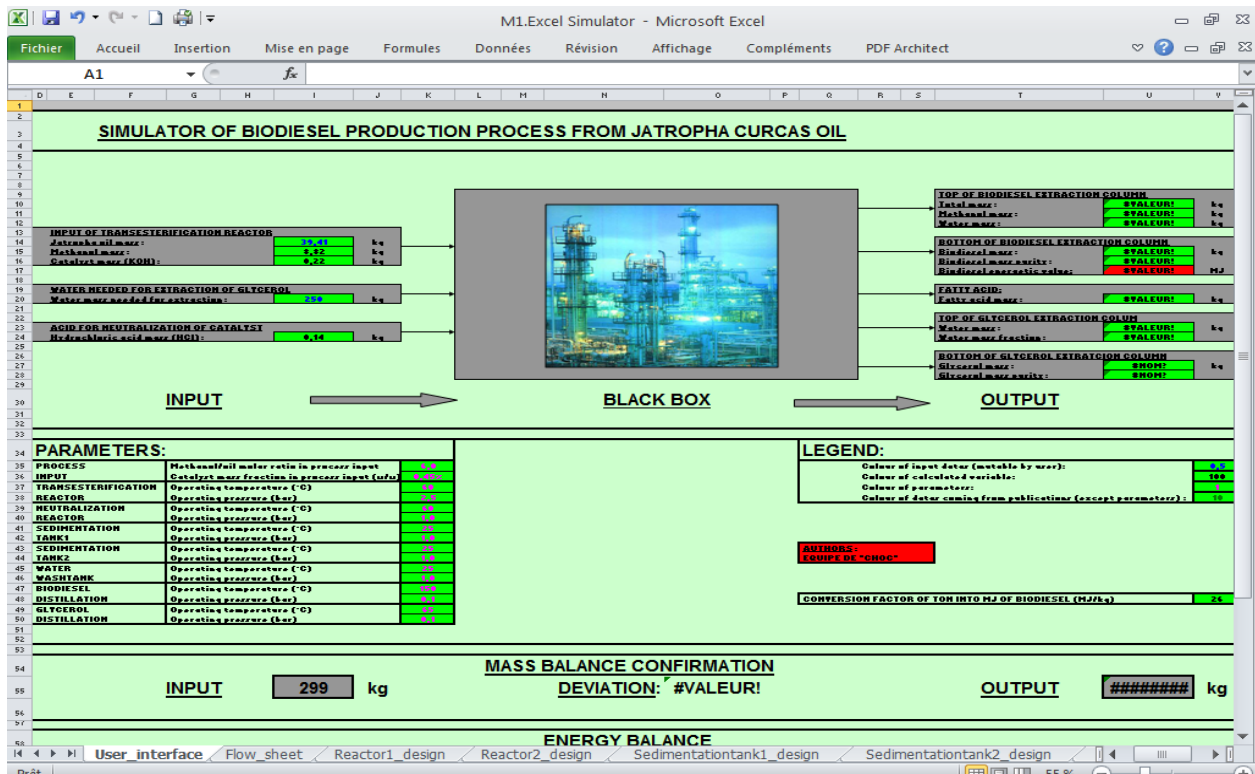
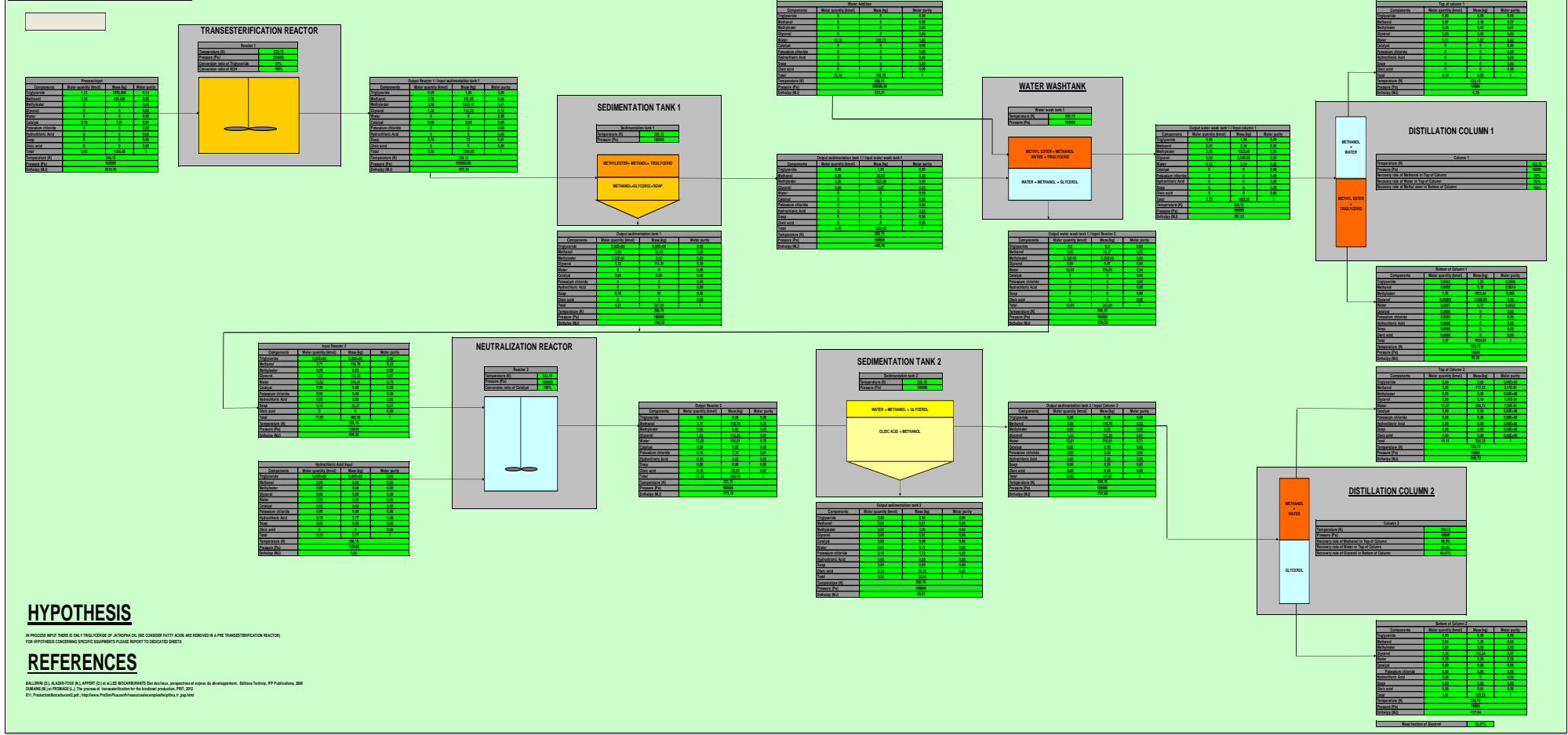

Figure 53 screen shot of user interface of the simulator in Microsoft Excel

In this file, data sheet containing the molar masses of the components is a sheet used for the calculation of various materials and energy balances. Sheet regarding "flowsheet" is in complete interaction with all other sheets in the workbook: the input data for equipment are sent to pages for treatment for specific apparatus that return the details about outputs to the outlets flowsheet for materials and energy equipment. Most of the calculations for the reactions, liquid-liquid equilibrium, and liquid-vapor enthalpy are concentrated in specific sheets dedicated to each apparatus. Comparing the results with other specialized process software as Prosim Plus, it is now clear that our Excel simulator is really efficient. In order to well structure this report, the comparison of the results between Excel and Prosim Plus is presented in another part. Following figure shows the detail overview of Excel simulator developed (Figure 54). Other screen shots of Excel process simulator for Transesterification are presented in the appendixes 15.7

# PROCESS FLOWSHEET



## HYPOTHESIS

IF PROCESS SETUP THERE IS ONLY TRIGLYCERIDE OF ATRIPAL OIL (WE CONSIDER FATTY ACIDS ARE REMOVED IN A PIPE TRANSFERIFICATION REACTOR) FOR HYPOTHESIS (CONSIDER SPECIFIC COMPONENTS FLUXES REPORT TO SUBSEQUENT SHEETS)

## REFERENCES

SHILLON, D.L., AL-DAR, T.O.S., EL-APRIFY, G.I. et al. LBD BIOCOMBUSTIBLES: THE FUTURE. Proceedings of the 4th International Conference on Energy, Environment, and Technology, 2002.  
 DURAND, R., LA FROISSARD, J., The present transesterification for the biodiesel production. PFC 2002  
 E11: Product@BioEnergyLab.com - [http://www.PFC2002.com/transesterification/step1\\_1.pdf](http://www.PFC2002.com/transesterification/step1_1.pdf)

Figure 54 Process flowsheet for Excel simulator of transesterification



---

It is worth remembering that Microsoft Excel is a software that allows starting only create tables for calculation and analyze data (i.e. a spreadsheet) and in no case may be considered as effective and dedicated software specifically for modeling chemical process (such as Prosim Plus, Aspen, Hysys).

However, the coupling of tools and chemical thermodynamic calculations (such as component Simulis) it is possible to obtain a new tool in the case of simple processes to obtain a model similar to that of specialized software. Because of the strong hypothesis made and the ease of separation of the different compounds present and the simplicity of the "flowsheet" of overall process it was possible to effectively model the process of transesterification of *Jatropha curcas* oil.

➤ **Jatropha oil**

One can imagine that in reality, a very refined palm oil still contains impurities (by free fatty acids). In addition, the absence of free fatty acids in the entry point of process makes it almost useless certain equipment and in particular the second separator for separating the free fatty acids (for this occasion only because of the reaction of formation of fatty acids in the neutralization reactor) from glycerin. However, we decided to retain the decanter to allow future users of this simulator to implement the changes necessary to address this problem.

➤ **Transesterification reactor**

One possible criticism of this Excel file is on the model adapted for the reactions taking place in the transesterification reactor. Need triglyceride in both reactions of this reactor was a problem (we were not able to accurately determine the reaction kinetics) and forced us to consider two reactions in series and not in parallel. However, this strong hypothesis gives results close to reality because triglycerides have not reacted after the reaction of the transesterification reaction in required amount in order to allow the hydrolysis reaction to take place.

➤ **Neutralization reactor**

The problem here is again related to the model adapted to represent the behavior of our neutralization reactor. We assumed that the two reactions in the reactor took place in series (which is not necessarily the case and depends again on reaction kinetics). Under this strong assumption, we have considered the necessary introduction of hydrochloric acid in sufficient quantity in the reactor in order to satisfy the need for both acids for reactions.

➤ **Settler/Separator/decanter**

Distillation columns are the toughest part to be modeled in Microsoft Excel as synthetic Simulis functions have not yet been developed for this kind of device. That is why their modeling

in Microsoft Excel is only possible in case separation of the components where they are very simple (in our case) by treating them as flashes of vapor-liquid equilibrium.

➤ **Mass balance**

Overall, the material balances obtained through modeling in Microsoft Excel seem correct and very close to those obtained through modeling with specialized software. In addition it appears that, in the case where process modeling in Microsoft Excel is possible and simple, the resulted material balances are very reliable according to one imagination. This is because of the reason that material balance equations are simple (compared to energy balance equations, equilibrium multi-stage) to implement in software.

An important fact to verify the consistency of the results of our material balance is the overall conservation of matter (mass) throughout the process. However, in any other case it depends for confirmation that our flow values found are the actual process flow. This confirms that the equations for calculating cash material balances are correct (and our calculations average molecular weights using the equations of chemical reactions are correct).

➤ **Enthalpy balance**

Enthalpies balances are shown through Microsoft Excel are meanwhile much criticism then that of material balances. The main problem lies in the distillation columns. Indeed how to make (specifically with data in Microsoft Excel) an enthalpy balance on a representative distillation column whereas we chose to model for a flash vapor-liquid equilibrium? Critical global energy balance of the process is mainly because of the modeling choices selected to build the Microsoft Excel file. In case where the Excel model was close to that of Prosim Plus (means all equipment except distillation columns), enthalpy balances obtained are very close each other (relative deviations calculated between Prosim Plus and Excel simulators). But the biggest approximation comes from the choice of thermodynamic model, modified UNIFAC (Dortmund) 1993, which is a predictive model and must be objected to empirical verification.

## 10.4 PROCESS SIMULATOR THROUGH PROSIM PLUS

### 10.4.1 *From process continue to process discontinue*

Prosim Plus is a PSE tool that performs assessments of materials and energy for a wide range of industrial processes in the steady state. It is used both in design operations for the optimization of chemical processes engineering such as distillation of mixtures of compounds whose properties can be calculated by thermodynamic models. The Transesterification is modeled by the Prosim Plus software according to the diagram shown in Figure 55. Prosim Plus is a continuous process simulator. However, the process that we study here is a batch process. The molar mass flows on Prosim Plus correspond to quantities and molar mass for our process. Enthalpy flows correspond in turn to enthalpies. The table below shows the grading and units



displayed by Prosim Plus and also the grades/levels and the corresponding unit in the real case for our batch process:

*Table 15 Table of equivalence between the variables in the continuous process Prosim Plus and magnitudes of discontinuous ESTERFIP process*

<b>Grades/levels and unit displayed by Prosim Plus</b>	<b>Real correspondents grades/levels and unit</b>
Mass flow, kg/s	Mass, kg
Molar flow, kmol/s	Molar quantity, kmol
Flow for enthalpy, W	Enthalpy, J

The main areas are the transesterification, methanol separation, water washing, FAME purification, catalyst neutralization and glycerol purification. The equipment used includes in particular reactors, distillation columns, and extraction columns and components splitters. Description of the process follows as shown in the Figure 55.

Figure 55 Prosim Plus flowsheet modeling for ESTERFIP

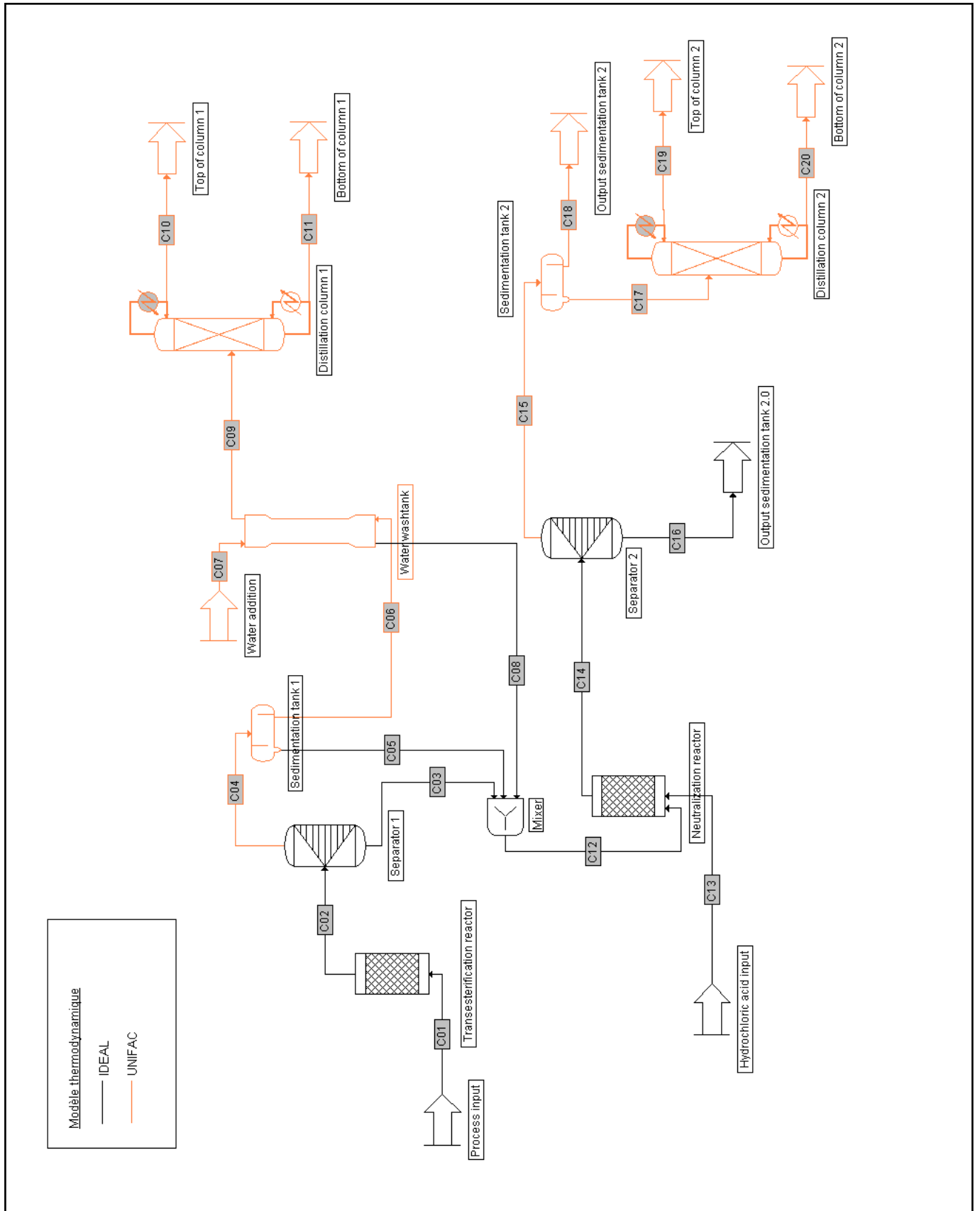

#### 10.4.2 Thermodynamic model and components used

To perform this simulation in Prosim Plus, we implemented two calculation steps:

- IDEAL, based on the ideal thermodynamic model
- UNIFAC based on the modified thermodynamic model UNIFAC (Dortmund) 1993

The IDEAL model is applied to the following components:

- Triolein
- Methanol
- Methyl oleate
- Glycerol
- Water
- Potassium hydroxide
- Potassium chloride
- Hydrogen chloride
- Potassium oleate
- Oleic acid

The UNIFAC model contains the following components:

- Triolein
- Methanol
- Methyl oleate
- Glycerol
- Water
- Oleic acid

The system contains polar components (such as methanol and glycerol), which implies strong interactions in liquid phase. The operating pressure being low (from 0.1 to 1 bars), the vapor phase behavior can be assimilated to an ideal gas. The equilibrium data for the binary systems not being available, a predictive model, based on group contribution, the Dortmund modified version of UNIFAC and IDEAL model was selected. The Triolein UNIFAC decomposition is obtained from its chemical structure:

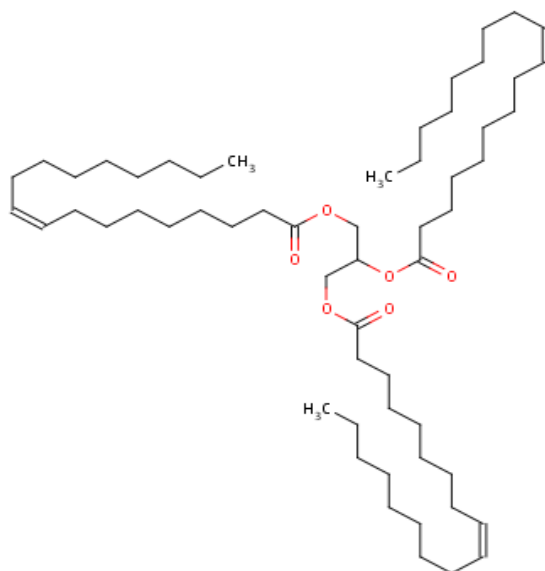

Figure 56 Structure of Triolein

Data on these components have different origins. The following table summarizes the origins and specifies the substance that modeled each constituent (Table 16):

Table 16 Origin of different constituents used for Prosim Plus simulator

Prosim Plus constituents	Substance for modeling	Origin of data in Prosim Plus
Triolein	Jatropha oil	TRIOLEIN modified
Methanol	methanol	Prosim Plus DB
Methyl oleate	biodiesel	Prosim Plus DB
Glycerol	glycerin	Prosim Plus DB
Water	Water	Prosim Plus DB
Potassium hydroxide	Potassium hydroxide (catalyzer)	Prosim Plus DB
Potassium chloride	Potassium chloride	Prosim Plus DB
Hydrogen chloride	Chloric acid	Prosim Plus DB
Potassium oleate	Soap	METHYL OLEATE modified
Oleic acid	Fatty acids	Prosim Plus DB

TRIOLEIN is selected for modeling Jatropha oil through modified UNIFAC parameters (Dortmund) 1993 as discussed in ProSim (2012).

Due to unfit POTASSIUM OLEATE for meaningful modeling of soap in Prosim Plus, we modified the compound METHYL OLEATE that by itself was present in the version ENSIACET Prosim Plus whose chemical formula ( $C_{19}H_{36}O_2$ ) was closer to that of POTASSIUM OLEATE ( $C_{18}H_{33}KO_2$ ). We were able to create the component POTASSIUM OLEATE in Prosim Plus whose behavior is close enough potassium oleate and also for soap as well. Therefore the

name, CAS number, chemical formula and the molar mass of the new constituent were considered. These data are given as under (Table 17):

Table 17 Properties of the constituent present in Prosim Plus

Attribution	Value
Name	POTASSIUM OLEATE
CAS number	143-18-0
Chemical formula	C18H33KO2
Molar masse	320,55

This component has the same properties as METHYL OLEATE. UNIFAC (Dortmund) 1993 modified parameters are also those of METHYL OLEATE, but this component cannot be used in sections where the UNIFAC model is used because the UNIFAC does not adopt this new component.

#### 10.4.2.1 Unitary operations

Unit operations of ESTERFIP process were modeled by the unit operations of Prosim Plus following, the thermodynamic models used for each unit operation which are specified (Table 18):

Table 18 Unitary operations used in Prosim Plus for ESTERFIP process modeling

ESTERFIP Unitary operation process	Modeling in Prosim Plus	Thermodynamic Model
Transesterification Reactor	Simple Reactor	IDEAL
Decanter/settler 1	Decanter/settler	UNIFAC
Decanter/settler 2	Decanter/settler	UNIFAC
Column for washing through water	Extraction column	UNIFAC
Distillation column 1	Distillation column with total condensation	UNIFAC
Distillation column 2	Distillation column with total condensation	UNIFAC

Figure 55 provides the flowsheet where the legend illustrates thermodynamic models used in each part of the process, and followed by the Table 39 in appendixes 15.6 that highlights the streams.

#### ➤ Reactors

At the transesterification and neutralization reactor, the operating conditions are the same as those of the Excel file:

Table 19 Operating condition present at reactor

	Transesterification Reactor	Neutralization reactor
Temperature (°C)	60	60
Pressure (bar)	2,5	1

<b>Conversion rate for transesterification</b>	0,97	-
<b>Conversion rate for saponification reaction</b>	1	-
<b>Conversion rate for neutralization reaction</b>	-	1
<b>Conversion rate for fatty acids</b>	-	1

### ➤ Distillation column

Separation by distillation is very easy; the parameters determination Shortcut method gave minimum negative reference flow. Parameters in distillation column are therefore obtained manually in a way to obtain the desired separation with minimal theoretical level, reference flow and heat supply to the boiler.

The parameters presented are as follow (Table 20):

Table 20 operating condition present at distillation column

	<b>Distillation column 1</b>	<b>Distillation column 2</b>
<b>Number of theoretical compartments</b>	2	2
<b>Feeders</b>	2	2
<b>Operating pressure</b>	1 bar	1 bar
<b>Molar conversion rate</b>	0	0
<b>Heat provider to boiler</b>	390 000 000 W	40 000 W

### ➤ Column for washing (water)

Washing with water steps are also straight forward and easy to perform. A two theoretical compartment washing column was considered. Water flow in input was set at 250 kg/h.

### ➤ Decanter/Settler

The two settlers operate at room temperature and at atmospheric pressure i.e. 25° C and 1 bar.

#### 10.4.3 Critical comparison of Prosim Plus and Excel simulator results

The hypotheses used in the Excel simulator and for Prosim Plus simulator are very close. The results in Prosim Plus are similar to the Excel simulator. You can always criticize the results in these columns because of the ease of separation of the incoming mixture. Even if the distillation columns were modeled by dedicated modules of Prosim Plus. Here again, for more suitable results and the establishment of a distillation nearest to the actual process, the inclusion of the fatty acids as input is important and required.

This comparison was particularly meaningful because it allowed us to find errors both at Excel simulator level and also for Prosim Plus simulator. The calculation of the relative difference is relevant because not only it allows the comparison of error for the values with different orders of magnitude (mole fraction and temperature in Kelvin) but also for small values, including traces of some compounds in common flow which are quite insignificant and it has little interest. Relative differences magnitudes calculated between Excel simulator and Prosim Plus are hereby presented in the Table 21.

It is noted that, except in distillation columns, Excel simulation and Prosim Plus simulation are quite similar. The relative differences that are greater than 100% are for low flow rates which are not relevant. On the other hand in distillation columns, there are noticeable differences rather large at the molar quantities and molar fractions of key components (within the meaning of distillation), total molar quantities of flow, temperatures and enthalpies. This is of course due to the model used to simulate distillations. In Excel, it is simple flash for liquid-vapor at a constant temperature and pressure while under Prosim Plus, the model of distillation column for total condenser is much more complex including the consideration of a temperature gradient along the column and the presence of two theoretical compartments. Using a flash QP model for distillation columns in Excel could give results closer to reality and closer to Prosim Plus simulation. However, to play with quantity of heat required is more difficult than playing on the temperature because we did not know at the base, the amount of heat we had access only to the temperature limit that should not exceed the constituents to be distilled.

Nevertheless, the results in Excel are the right order of magnitude even in the distillation columns. Errors are important for constituents in small quantities and other errors are reasonable. Process simulators for transesterification of *Jatropha curcas* oil developed in Excel and Prosim Plus is an essential tool for information and details on the flows of materials and energy that are necessary for the development of LCA that specifies the process of biodiesel production.

Despite all the assumptions made, the simulator developed in Excel gives results quite suitable. The next step to further refine Excel based LCA is the development of an LCA simulator for refining *Jatropha curcas* oil.

Table 21 Table of relative differences magnitudes calculated between Excel simulator and Prosim Plus

Courants De Vers	C01 Process input Transesterification reactor	C02 Transesterification reactor Separator 1	C03+C05 Sedimentation tank 1 Mixer	C06 Sedimentation tank 1 Water wash tank	C07 Water addition Water wash tank	C08 Water wash tank Mixer	C09 Water wash tank Distillation column 1	C10 Distillation column 1 Top of column 1
Quantité molaire parhele								
TRIOLEIN	-3%	-	-	-	-	-	-	-
METHANOL	0%	3%	3%	2%	-	9%	-173%	-173%
METHYL OLEATE	-	-3%	-	-3%	-	-	-3%	157%
GLYCEROL	-	-3%	-3%	-	-	-	-	-
WATER	-	-	-	-	0%	0%	-1%	1%
POTASSIUM HYDROXIDE	0%	-	-	-	-	-	-	-
POTASSIUM CHLORIDE	-	-	-	-	-	-	-	-
HYDROGEN CHLORIDE	-	-	-	-	-	-	-	-
POTASSIUM OLEATE	-	0%	0%	-	-	-	-	-
OLEIC ACID	-	-	-	-	-	-	-	-
Quantité molaire totale	0%	0%	1%	-2%	0%	1%	-4%	-27%
Fractions molaires								
TRIOLEIN	-3%	-	-	-	-	-	-	-
METHANOL	0%	3%	2%	4%	-	8%	-172%	-165%
METHYL OLEATE	-	-3%	-	-1%	-	-	1%	166%
GLYCEROL	-	-3%	-4%	-	-	-	-	-
WATER	-	-	-	-	0%	0%	3%	28%
POTASSIUM HYDROXIDE	0%	-	-	-	-	-	-	-
POTASSIUM CHLORIDE	-	-	-	-	-	-	-	-
HYDROGEN CHLORIDE	-	-	-	-	-	-	-	-
POTASSIUM OLEATE	-	0%	-1%	-	-	-	-	-
OLEIC ACID	-	-	-	-	-	-	-	-
Température	0%	0%	0%	0%	0%	0%	0%	-60%
Pression	0%	0%	0%	0%	0%	0%	0%	0%
Enthalpie	-3%	1%	0%	2%	0%	0%	3%	-36%
Courants	C11	C12	C13	C14	C16+C18	C17	C19	C20
De	Distillation column 1	Mixer	Hydrochloric acid input	Neutralization reactor	Sedimentation tank 2	Sedimentation tank 2	Distillation column 2	Distillation column 2
Vers	Bottom of column 1	Neutralization reactor	Neutralization reactor	Separator 2	Output sedimentation tank 2	Distillation column 2	Top of column 2	Bottom of column 2
Quantité molaire parhele								
TRIOLEIN	-	-	-	-	-	-	-	-
METHANOL	-	4%	-	4%	5%	4%	2%	101%
METHYL OLEATE	-3%	-3%	-	-3%	-	-3%	-	-3%
GLYCEROL	-	0%	-	0%	-	0%	-1%	29%
WATER	-	-	-	-	-	-	-	-
POTASSIUM HYDROXIDE	-	-	-	0%	0%	-	-	-
POTASSIUM CHLORIDE	-	-	-	-	-	-	-	-
HYDROGEN CHLORIDE	-	-	-	-	-	-	-	-
POTASSIUM OLEATE	-	0%	1%	-	-	-	-	-
OLEIC ACID	-	-	-	-	-	-	-	-
Quantité molaire totale	-4%	1%	1%	1%	1%	1%	-1%	12%
Fractions molaires								
TRIOLEIN	-	-	-	-	-	-	-	-
METHANOL	-	4%	-	4%	4%	4%	3%	92%
METHYL OLEATE	0%	-4%	-	-4%	-	-4%	-	-15%
GLYCEROL	-	-1%	-	-1%	200%	-1%	-1%	17%
WATER	-	-	-	-	-200%	-	-	-
POTASSIUM HYDROXIDE	-	-	-	-	-1%	-	-	-
POTASSIUM CHLORIDE	-	-	0%	-	-	-	-	-
HYDROGEN CHLORIDE	-	-	-	-	-	-	-	-
POTASSIUM OLEATE	-	-	-	-	-	-	-	-
OLEIC ACID	-	-	-	-	-	-	-	-
Température	10%	0%	0%	0%	0%	0%	-11%	-5%
Pression	0%	0%	0%	0%	0%	0%	0%	0%
Enthalpie	-12%	0%	-	0%	2%	2%	-6%	-9%



---

## 11. SimLCA framework for biofuel production system

---

This section is dedicated to the process simulation interoperability for further integration into the present framework of LCA. The direct coupling between the well-known commercial applications (i.e. SimaPro for LCA and Prosim Plus for PSE) is arduous not only for the whole production system but also for the transesterification unitary process and would request for advanced IT competences. The application developed through this simulation is termed as “**SimLCA**” with the help of Visual Basic supported by the Microsoft Excel framework. On the one hand, it was thought out similar to SimaPro calculation process, while on the other hand, the unitary chemical process under consideration is simulated through a dedicated simulator relied on the Simulis thermodynamic server. Furthermore this development of simulation based LCA framework can serve as a step forward for determination of sustainability and eco-efficient designing.

## 11.1 GENERAL STRUCTURE OF SIMLCA

The aim is to better understand the production process of biodiesel from *Jatropha* and their respective environmental impacts it generates. Thus, this work includes the construction of our frame according to two dimensions, LCA and PSE; which is further dedicated to the analysis of the life cycle for a non-food agro-process (*Jatropha* biodiesel). The second aim was to validate the whole project by comparing with SimaPro. The target of our tool is obviously not to model the entire scheme of SimaPro. It is dedicated to the environmental assessment for *Jatropha* biodiesel production process domain and eases the integration of PSE in order to improve such analysis. From a first shot based on a pure LCA study, it was revealed that the most impactful part of biodiesel production global chain is the transesterification sub-process (as discussed in Part B). In order to have a better understanding of the reaction of transesterification, it is necessary to be aware of its role in the complete process which permits to turns oils or fats to biodiesel. For a good conversion rate, we study the influence of different parameters on the reaction of transesterification such as side reactions (saponification and hydrolysis), thermodynamic model and kinetics of transesterification.

A simulation on Prosim Plus was done to check the results we obtained on the Excel simulator (as discussed in chapter 10).

Scope and limits of our Life Cycle have to be well defined because our system does not include all the process of biodiesel production with *Jatropha curcas*. The system extends from the cultivation of the plant *Jatropha curcas* to the biodiesel production, and for all the duration of the plant cultivation, which is approximately 30 years. Crop fields are located in Ivory Coast and the refining and transesterification parts take place in Le Havre (France). This system includes the following steps: nursery, transplantation, transport, refining and transesterification.

The functional unit chosen is the MJ of biodiesel. Thus, in order to have a simple Excel tool, main specific substances for *Jatropha* system have to be selected. Besides, only two methods are used: Impact 2002+ and CML 2 Baseline.

Another aspect of this file is to consider the coupling with a tool for life cycle analysis that we have developed in Microsoft Excel. This side project has strengthened our idea of setting up a page user interface to simplify the maximum understanding for a user who is not an expert of process and production.

Figure 57 shows the basic approach for structuring the dedicated framework (SimLCA) that allows a "simulated LCA" applied to the *Jatropha* biodiesel production. The last step before linking process simulator and LCA is to compare simulator on Microsoft Excel and Prosim Plus. Indeed, the same results have to be obtained in order to efficiently use this tool. Even if results are not exactly the same, they are similar enough in order to obtain the same conclusion concerning a life cycle assessment for *Jatropha* field. Once the LCA is completed and checked

on Excel, we couple it with the Jatropha oil transesterification. So when data are changed in the Excel simulator, the LCA hence get updated. Furthermore, to make this coupling more pertinent, simulation of other steps of the biodiesel production process could be done (nursery, transplantation, harvest and refining).

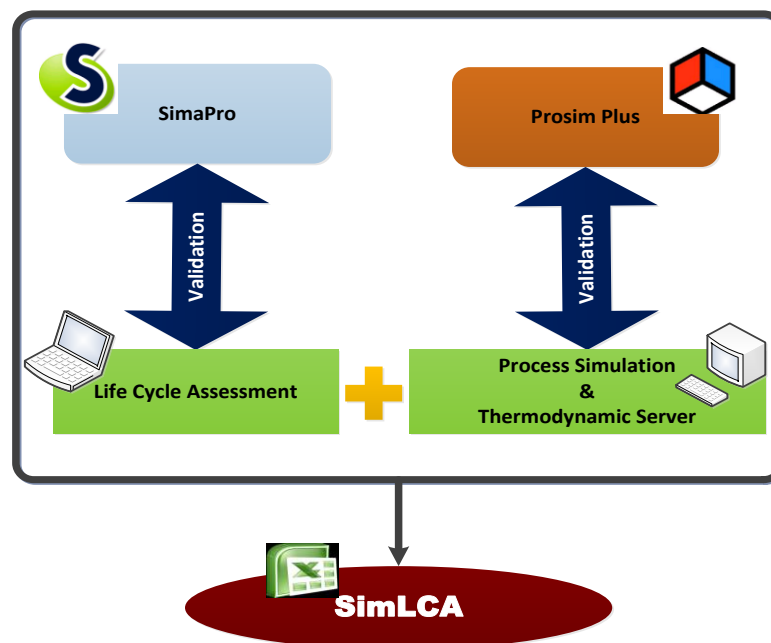

Figure 57 Approach for SimLCA structure

The SimLCA tool is developed in Visual Basic supported by the Microsoft Excel framework. At the end the application is structured to make it user-friendly and efficient. That is why it was decided to create one main sheet (user interface) in which any user is able to configure all the process and LCA parameters before running SimLCA.

So far, LCA has been mainly used to study and highlight key methodological points for environmental analysis of agro-process. However, this study and other studies encountered previously for LCA of processes are conducted to fixed operating conditions that can be derived from experimental sites or simulations and considered an optimal point of view in technical and economic aspects. However, the question arises about how to manage the variability of operating conditions during the LCA of production process. The objective is to show how LCA can be combined with chemical engineering approach for optimizing unitary operations?

PSE methods and tools permit us to simulate the whole process, a part or a unit operation. In our research work, we use PSE to model and simulate the transesterification, one part of our development process of the biodiesel production for its life cycle assessment. One core objective is so the implementation of an application which simulates the transesterification sub-process of *Jatropha curcas* oil. This process simulator is linked with the Life cycle

assessment (LCA) of the global production process. Figure 58 shows the basic structure of our framework that allows a “simulated LCA” applied to the Jatropha biodiesel production.

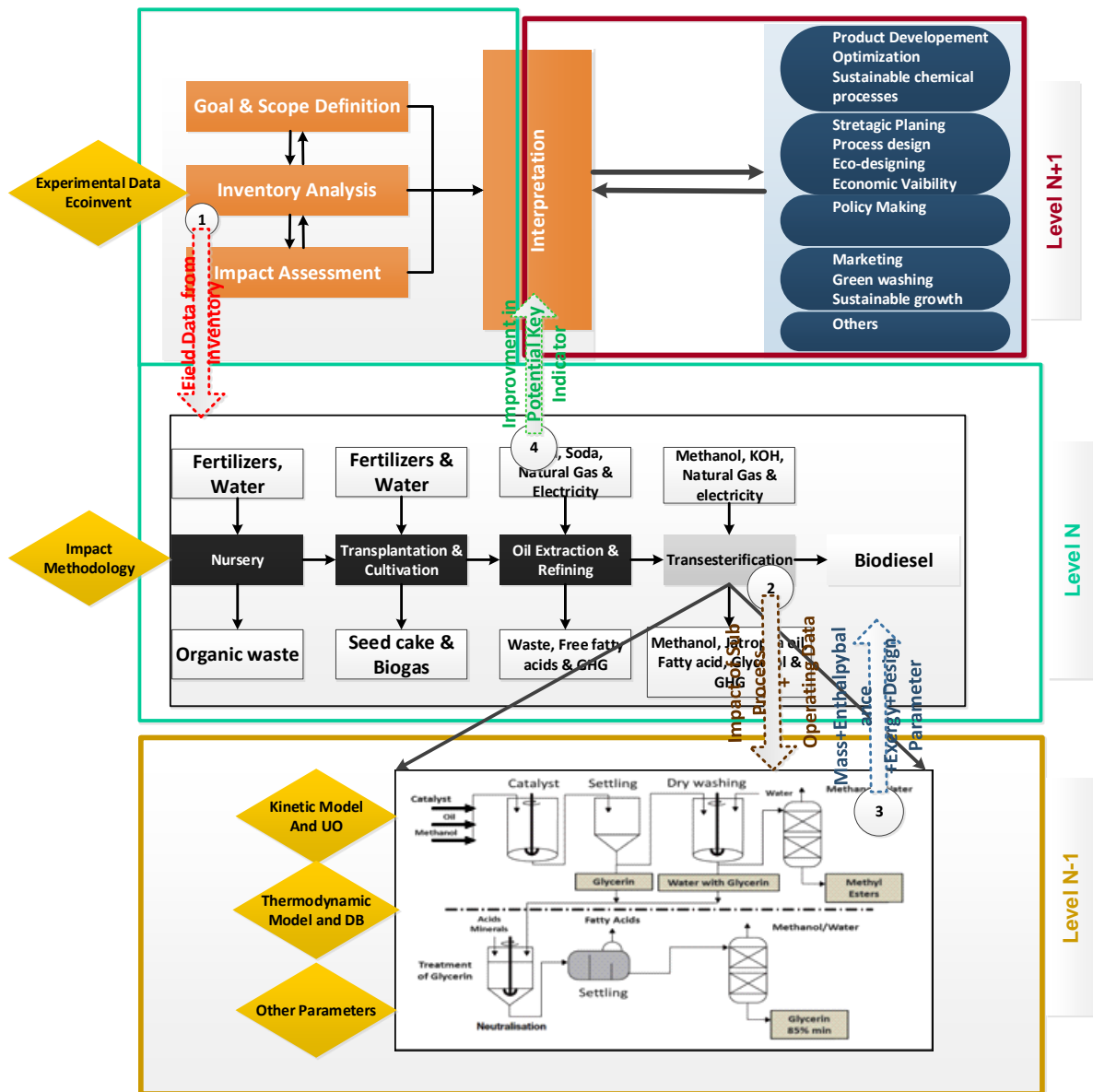

Figure 58 Overview of present Framework

We study only the environmental side here with the identification of two approaches; either embedding process dimension in LCA work or embedding LCA dimension in process design. (Morales-Mendoza et al., 2012) introduce a frame which is chemical engineering oriented and is therefore based on the LCA embedded PSE approach. Our frame complies with the former approach as the primary purpose is to improve the present environmental assessment of biodiesel production global chain.

Figure 58 provides an overview of the proposed framework. This whole concept has been divided in three phases which start with an ISO 14040-14044 framework for LCA (Phase-I) with

the help of experimental data and Ecoinvent. Then it extends to global production chain (Phase-II) of non-agro food through evaluation of its impact assessment. In our case the simulation of global production chain in a whole is a rare possibility so a sub process of transesterification (Phase-III) is chosen which is termed as the most impactful category in the light of previous studies. Further this transesterification is simulated through the inclusion of its kinetic model, thermodynamic model and other parameters. This simulator provided by this whole phenomenon could then be integrated in LCA in order to achieve SimLCA at the end. In this whole phenomenon there is a continuous flow of information which has been represented by numbered arrows. First is the information flow for field data:

- a) From inventory analysis followed by impacts of sub processes and operating data
- b) From global production chain to sub process for simulation.
- c) Then there is a flow of information in upward direction related to mass, energy and enthalpy balances along with design parameters
- d) In the last flow we can then indicate potential key parameters (For the improvement of whole system)

There is always a supposition of internal loops in-between two layers or even for the whole system. In our case this iterative workflow is two tier between layer I & II and single tier between II & III. In the light of this proposed concept we can now provide a simulation based LCA where there is an opportunity to systematic analysis and design through the information flow down and upward direction.

## 11.2 INFORMATION FLOW OF SIMLCA

Specification of a production system must include all relevant static and dynamic aspects of the domain. Dynamic aspects are usually specified by means of a behavioral schema consisting of a set of system operations that the user may execute and update in the present state of system. Operations in the schema are drawn from the static aspects of the domain as defined in the UML class diagram (Figure 48) and take into account possible dependencies among them to ensure the completeness and executability of the operations. From here we proceed towards object diagram (Figure 59) which is an instance of a class diagram and illustrates the state of a system at a given time. An object diagram focuses on some particular set of objects and attributes, and the links between these instances.

The object diagram shows the different objects (only important ones) that pass through the case study for coupling of LCA (SimLCA) with process simulation tool applied to the production of biodiesel from oil *Jatropha*. This is a sample of objects that are exchanged between the various sectors of experts through certain messages (process engineer, supply chain engineer, environment engineer). For simplicity measures, the objects of model are the

objects used by the three levels of professional expertise in Figure 47. The links are not shown to avoid overloading the diagram. Objects are divided into “package” and each “package” has a level of expertise to which the object is assigned. The allocation is performed according to the principle responsibility level by object manager.

Important messages are related to the flow of matter and energy which is often needed by environment engineer. These messages correspond to the information that passes between the different layers. For example, the environment engineer can know the value of certain flow under given conditions with the help of literature on the subject while the process engineer can have it from another source or directly from simulations. In the object diagram, the flow is allocated in the process since it is environment engineer who is responsible for validating the information using the expertise of the process engineer and simulation results.

The determined parameter of the model comes from the special layer with different expertise. The impact factors that are considered as parameters are directly related to the flow. The parameters with allocation factor are controlled by the environment engineer. Then functional unit is also the responsibility of the environment engineering to be précised and setup. Temperature, pressure and the conversion efficiency of the crude oil into methyl ester are specific parameters related to the process engineer and the distance parameters are the ones that can be determined by the supply chain engineers. The white dots in the given object example indicates that there are other parameters involved but only few are presented here.

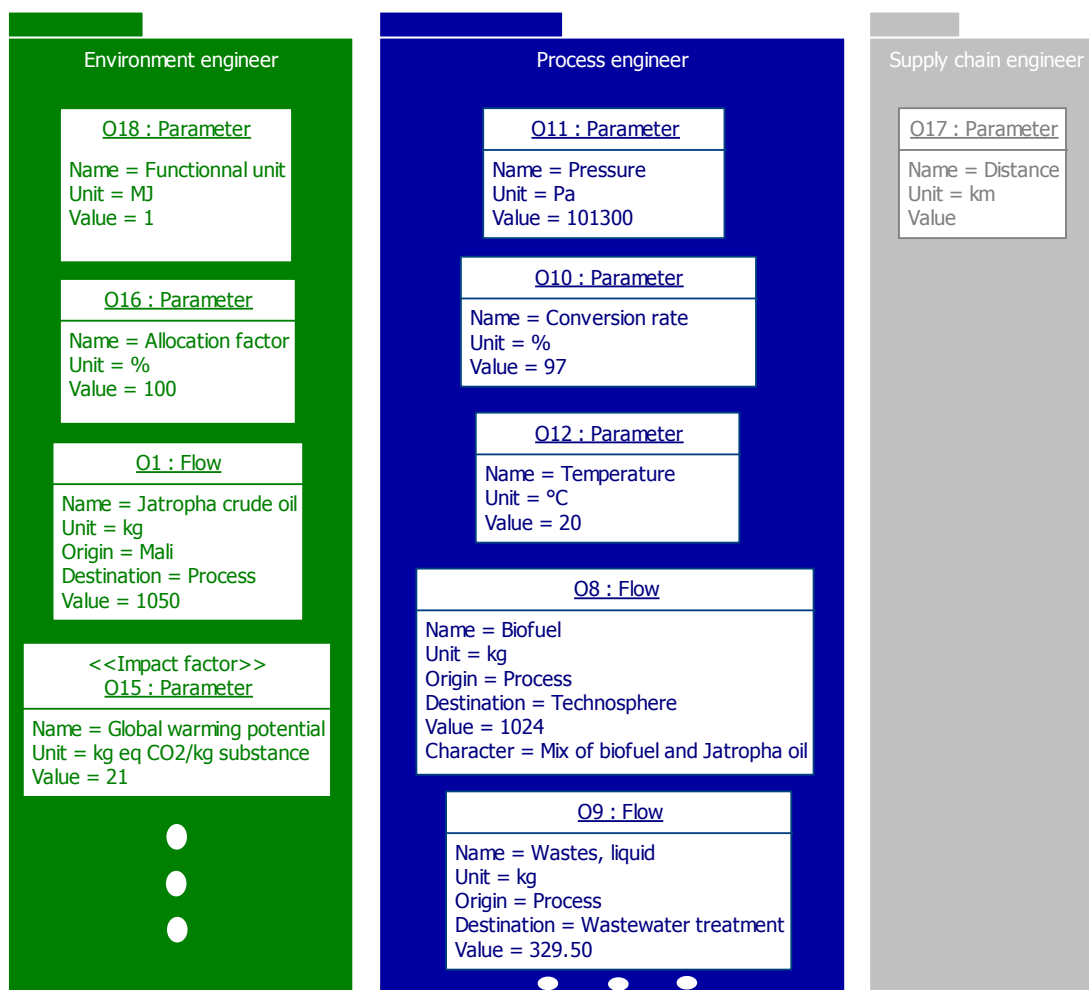

Figure 59 Example of objects for proposed framework

### 11.3 PRESENTATION OF SIMLCA

The simulator in SimLCA must be easy to use, scalable and have a user friendly interface. This tool is constructed as SimaPro to follow the maximum steps. In the first place it provides a first page that converts the data entered by the user or derived for coupling with the transesterification operation modeling with a selected functional unit. This unit is MJ by default, but another functional unit can be added to the simulator.

A second page serves as the main user interface. It allows the user to choose the method and the database before displaying the results. For the moment, only Ecoinvent data base and CML 2 Baseline 2000 and Impact 2002+ are implemented in SimLCA. Figure 58 shows the detail overview of thought out framework and by nature it is an iterative framework with the philosophy of “RE” i.e. re-think the product and its functions for LCA, re-place harmful substances with safer initiatives, re-use by designing the product and re-duce energy, material

consumption for the improvement of overall phenomena. The whole framework is divided into three main blocks with different sub-phases and there is a flow of information i.e. with top down and bottom up flow of information.

First it starts with layer-I<sup>4</sup> which drives LCA of global chain production in layer-I. Then layer II leads to simulation of the given chemical process of transesterification in layer-III by doing the pre-analysis and identification of chemical components and properties with the help of process inputs and outputs. From layer-I to layer-II we have a flow of field data coming from inventory analysis. Then the second work flow for impact of sub processes and operating data has a top down influence. Then we have the bottom up flow related to mass balance and enthalpy balances through thermodynamic and kinetic model for transesterification. 4th one is the potential key indicator improvement with bottom up flow.

#### **Data base table and methods:**

Two tables are particularly important for the development of SimLCA:

- The table that sort lists for each input emissions and resources consumed for above identified substances. This table was filled from substance to substance through Ecoinvent from SimaPro database. When multiple values of the same substance are found for a given input.
- The table, for each impact category, illustrates the value of a substance for which characterize the impact category for that substance. For example, all values are reported in CO<sub>2</sub> equivalent for the category of global warming. It is important that this table is fully informed in order to facilitate subsequent matrix computations. This table is filled for each impact category, thanks to the display methods in SimaPro.

These tables are made from the same entrance point on the left for all substances in each compartment (such as emissions to water, air and soil, as well as raw resources). For each compartment it is preferable to classify substances in alphabetical order for the sack of simplified sorting in the table.

#### **Calculation of values for each impact category:**

This calculation is performed for each category in two intervals. The first step is to create, a table for each part of the process, of the same size as the one that lists the emission inputs. It is implemented by multiplying it with each column, which is specific to an input and the amount that is used.

---

<sup>4</sup> Each layer is subjected to flow of information in top-down and bottom-up manner.



The second step is to create a second table, once for each part of the process, which includes gross value for each input of each impact category. Sorting of this table is achieved through a simple matrix between the input column of the preceding table, and impact category column of the associated table containing the coefficients of conversion for each method.

Other tables are then used to compile the results, and then normalize and combine them till the end point (endpoint for Impact 2002+ method only). Here is a screen shot of SimLCA (Figure 60) and for detail screen shots consult the appendixes 15.7 of manuscript.

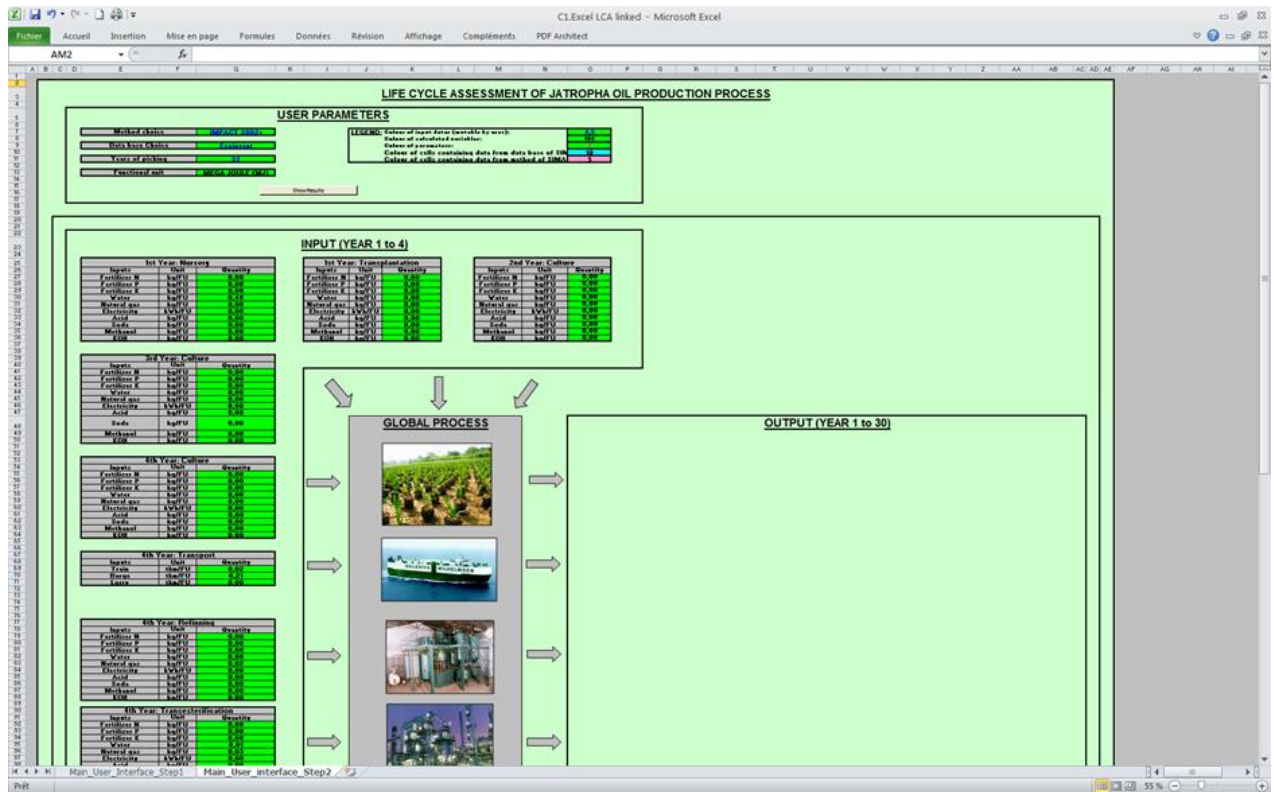

Figure 60 SimLCA main user interface

## 11.4 VALIDATION OF SIMLCA

We have solid background set for linking this process simulator with LCA and can get the acquired results/impacts through our own Excel base framework. There are different impact methodology consists of several impact categories. For this study, only the most significant impacts have been preserved after normalization. Concerning the method CML 2 Baseline 2000 Ozone layer depletion impact has not been taken into account. On the other hand for Impact 2002+ method impact categories were taken into account are:

- Non-renewable resource depletion
- Global warming
- Ozone layer depletion
- Respiratory Inorganics

- Eco-toxicity
- Acidification
- Eutrophication
- Carcinogens and non-carcinogens

Indeed, only 8 impacts are relevant in the context of our life cycle for Impact 2000 + methodology. In addition, we have not considered the impact like "land occupation" because of a lack of data.

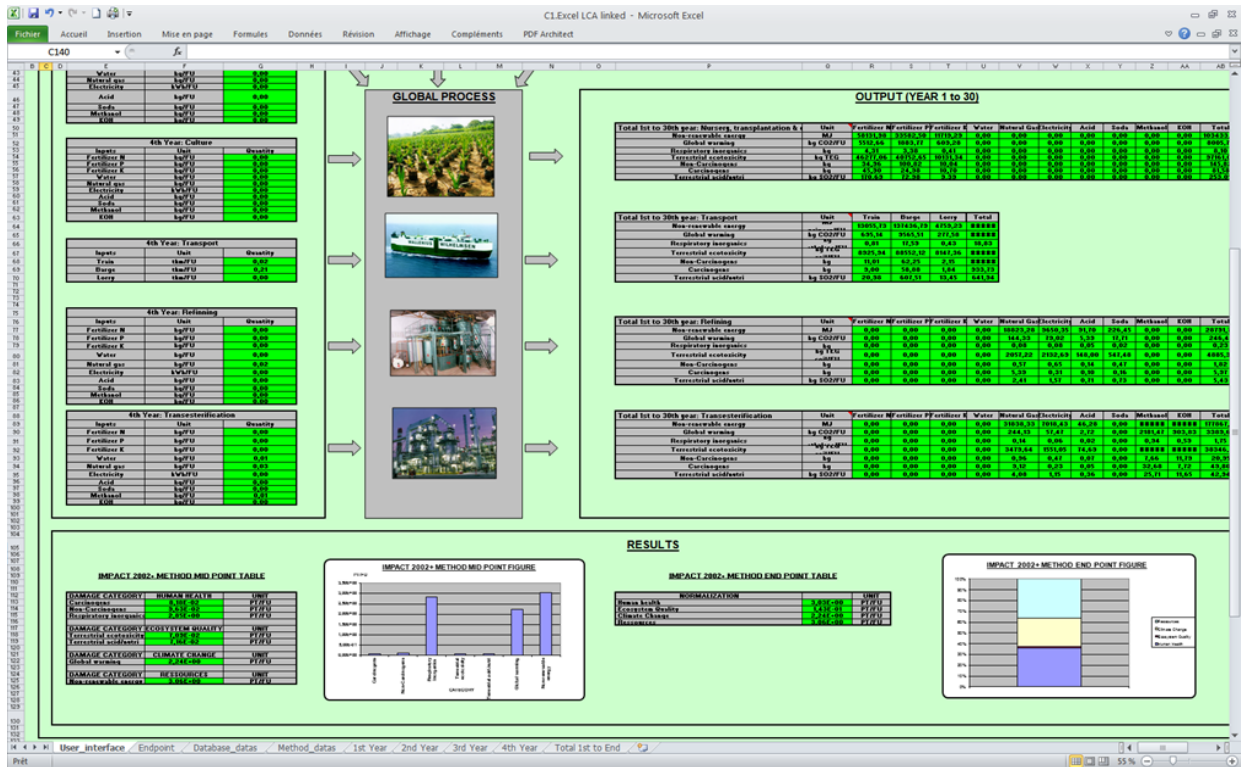

Figure 61 Screen shot of an established SimLCA

Here results in total are not discussed in detail. Instead we provide an insight of how these impacts has been calculated through SimLCA (For screen shots consult Appendixes 15.7 of Manuscript). In any case, the results between the two tools are similar enough to allow the same conclusions on an analysis of the life cycle which must nevertheless be specific to the production of biodiesel from Jatropha. After this validation we have a solid background to put forward a new integrated approach by combining process simulation and LCA for an eco-efficient design in agro-chemical engineering. In other words this study can serve as an opening to systematic process engineering and eco-designing which leads to optimization.

Excel allows to compare the results from SimaPro, and to couple it with another Excel file, that is transesterification simulator step in our case. However, SimLCA can be termed useful if it

provides results close enough SimaPro. The following graphs are used to compare results between SimaPro tool and SimLCA.

The results appear almost identical. SimaPro values are sometimes slightly larger because it takes all substances into account then that of selected ones for Excel. In any case, the results between the two tools are similar enough to allow the same conclusions on LCA, specific to the production of biodiesel from Jatropha (Figure 62 and Figure 63).

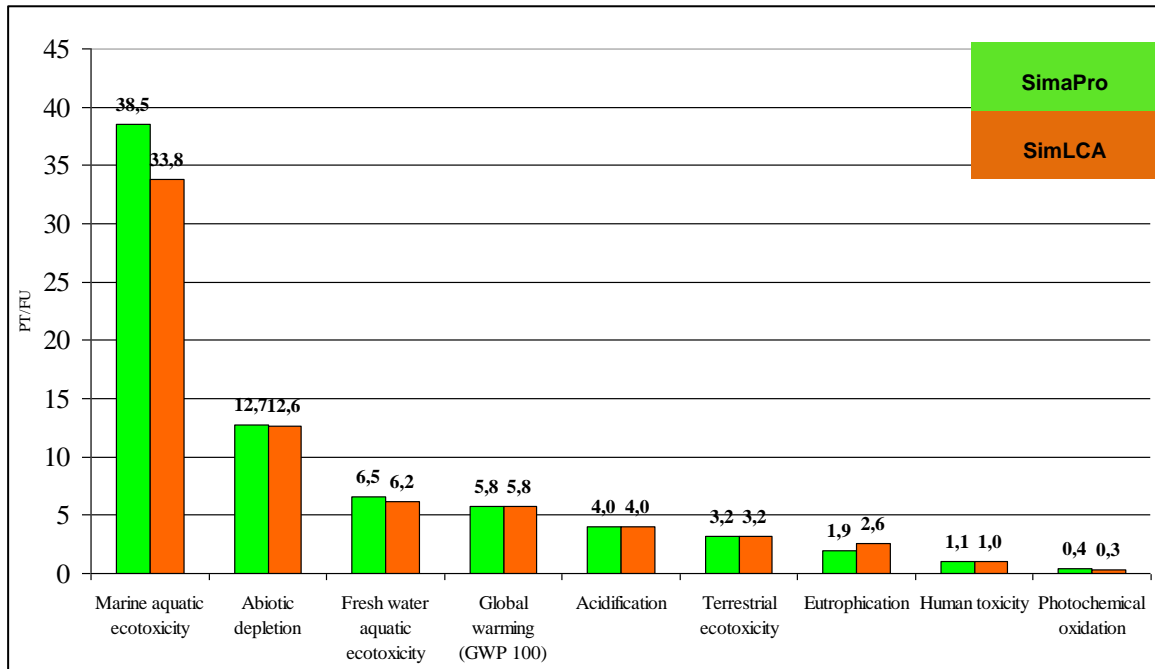

Figure 62 Comparison between results from SimLCA and SimaPro with CML 2 baseline 2000

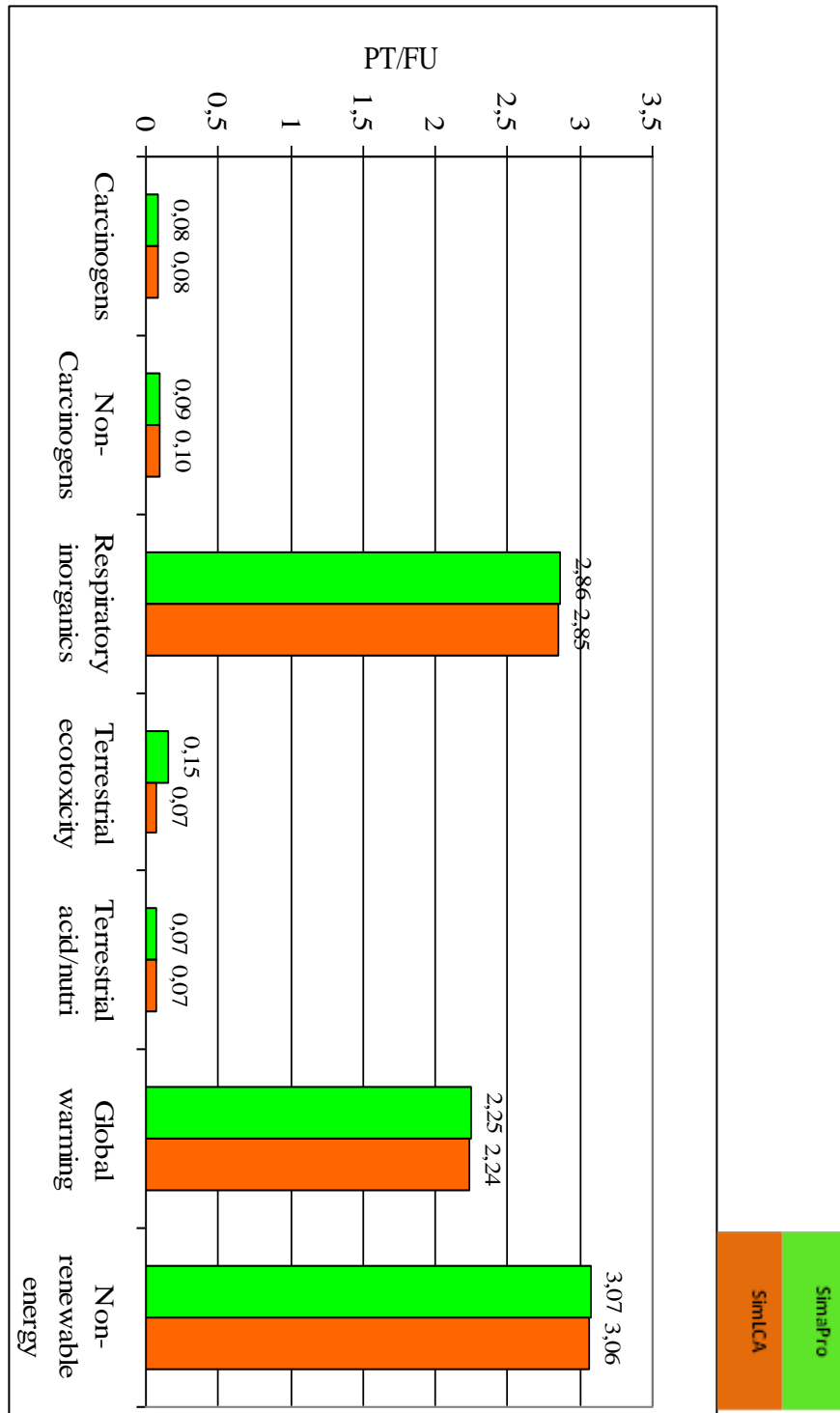

Figure 63 Comparison between results from SimLCA and SimaPro with Impact 2002

## 11.5 MAIN INTEREST IN LCA AND PSE COUPLING

There are more than one objectives linked with the integration of transesterification process simulator within LCA of *Jatropha* biodiesel in order to have a SimLCA application. First we start with phase-I which drives us to LCA of global chain production in phase-II. Then simulation of the given chemical process of transesterification in phase-III by doing the pre-analysis and identification of chemical components and properties with the help of process inputs and outputs. There is always a top-down and bottom up flow takes place between each phases. From phase-I to phase-II we have a flow of field data coming from inventory then the second work flow for impact of sub processes and operating data has a top down influence. Further we have the bottom up flow related to mass balance and enthalpy balances through thermodynamic and kinetic model for transesterification. Likewise study of (Vlysidis et al., 2011) shows the utilization of crude glycerol in transesterification can enhance the sustainability of bio-refineries. The coupling of this simulator with LCA of *Jatropha* biodiesel enables a direct automation of information flow between different phases. The interest here was to open a gateway for proposed eco-efficient process design. That has been used for sustainable production but they are not very up to the task in industrial practices.

It is now therefore possible to direct the user in order to modify these set of tools according to their own operating condition for a whole process. In our case for the process of transesterification we study the whole model and its impact on the entire production process. This simulation based LCA can now be very helpful to develop a more generic eco-efficient approach that can be used in the primary stage of production design. Another key interest here is that we can choose the best operating parameters by evaluating and finding different set of configurations. The approach presented here is used for analysis of specific process and can be applied to any process in the production chain of *Jatropha* biodiesel but the main hurdle here is the coherence of primary field data with operating data for simulation. Since our SimLCA application gives results similar to that of SimaPro hence we can say that this study could further leads us to social economic and (as in our case) environmental aspects which are the three main pillars of sustainability. In addition, the implementation of such a tool involves many assumptions that may significantly affect the LCA. The user must therefore ensure to take into account these assumptions and change if possible. The structure and process of construction of this SimLCA and associated iterative work flow can also be used for other environmental studies of non-food agro-processes.



---

## 12. Discussion and analysis from SimLCA

---

This chapter concludes part C related to our proposal for PSE embedded LCA approach for agro-processes. Results from different scenarios are evaluated and discussed. Analyses are made through a comparison of results from classic LCA method with the simulation based environmental analysis. Most of the results obtained are then tabulated in the appendixes 15.8.

## 12.1 ANALYSIS OF DIFFERENT SCENARIOS FROM SIMLCA

We have defined a framework that integrates process simulation for environmental evaluation and supply chain analysis. However, to implement this approach, the supply chain is simplified to a large extent when taken into account. We worked on an actual case study of Jatropha biodiesel production system. Then we pick the most impactful unitary process for simulation which at the end coupled with LCA for Jatropha to develop an integrated PSE based LCA framework. This whole study has been a way forward to future for PSE based environmental analysis of agro components since it allowed us to highlight process engineering and sustainability engineering. The coupling within one application (SimLCA) allows an automatic updating sequence of results whenever there is a modification in the operating conditions (conversion rate of the transesterification reaction, for example), and thus to deepen and refine the LCA which we termed as PSE embedded LCA.

The structure and associated workflow of SimLCA carries out the evaluation of environmental performance of non-food agro-processes. The future steps are especially important to integrate economic and social variables to current framework and to open the optimization option in sustainability. This section highlights the detail observation of results from simulated LCA (SimLCA) with that of classic LCA method. We illustrate the effect of interaction between a process engineer and environment engineer in the case of the study for biodiesel production system. The results are analyzed by comparing different scenarios. The configurations studied are of different forms that can take the system as follows:

- Integration or non-integration of avoided impacts associated with the production of glycerin
- With coupling or without coupling of process simulator
- The choice of the functional unit and the rate of impacts conversion.

This gives five scenarios from these configurations (Table 22):

*Table 22 Different scenarios for result evaluation*

Configurations	With or without coupling	With or without avoided impact of glycerin	Choice of functional unit	Evolution of conversion rate
Scenario 1 (table 39)	Without	Without	1 MJ of methyl ester	Fixed to 97%
Scenario 2 (table 40)	With	Without	1MJ of methyl ester + crude Jatropha oil	From 97% to 50%
Scenario 3 (table 41)	With	Without	1 MJ of methyl ester	From 97% to 50%
Scenario 4 (table 42)	With	With	1MJ of methyl ester + crude Jatropha oil	From 97% to 50%
Scenario 5 (table 43)	With	With	1 MJ of methyl ester	From 97% to 50%



### 12.1.1 Results with coupling and without coupling (scenarios 1 & 3)

This section compares the scenario 1 (Results Part B) with the scenario 3 for a fixed conversion rate to 97% so that the basic hypotheses remain the same. As shown in Table 40 (Appendix 15.8), without the coupling, the environment engineer cannot study influence specific and essential parameters such as conversion rates. It cannot evaluate the scenario 1. The objects manipulated by the environment engineer are therefore the objects of type “Flow” and “Parameter” as described in the information model (Figure 48). After coupling, it is possible to change the configuration of the system to establish multiple scenarios and then proceeds for a comparison.

After receiving a request from the environment engineer (object type “Comment”), the process engineer creates objects of type “Flow” (waste composition, composition of the final biofuel) and object of type “Parameter” (variable-rate conversion) transmitted to the environmental engineer. The coupling is therefore based on the establishment of an exchange of these objects between the different actors. This interoperability is ensured by the Excel programming in SimLCA.

To measure the importance of coupling, this subsection analyzes the differences observed between the results of the LCA before and after coupling. Table 45 in the appendix 15.8 expresses these results for relative difference. A positive percentage means that the results are lower than before coupling results, after coupling and vice versa. Figure 64 shows the midpoint impacts before and after coupling.

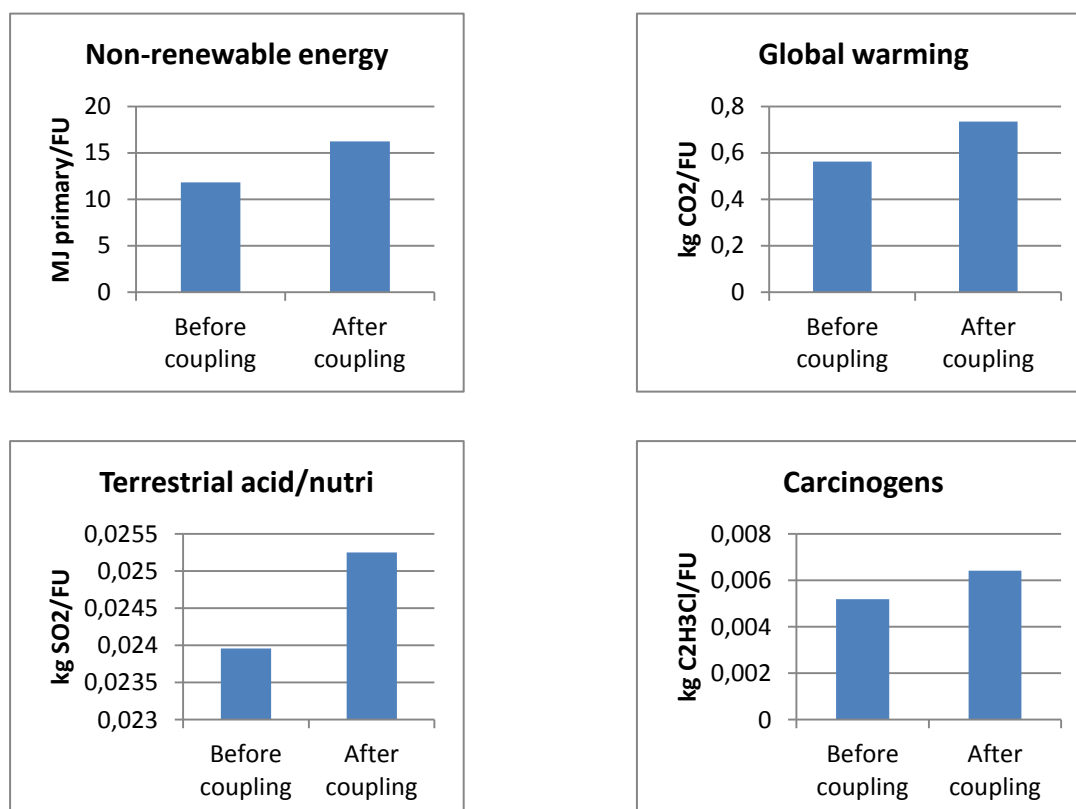

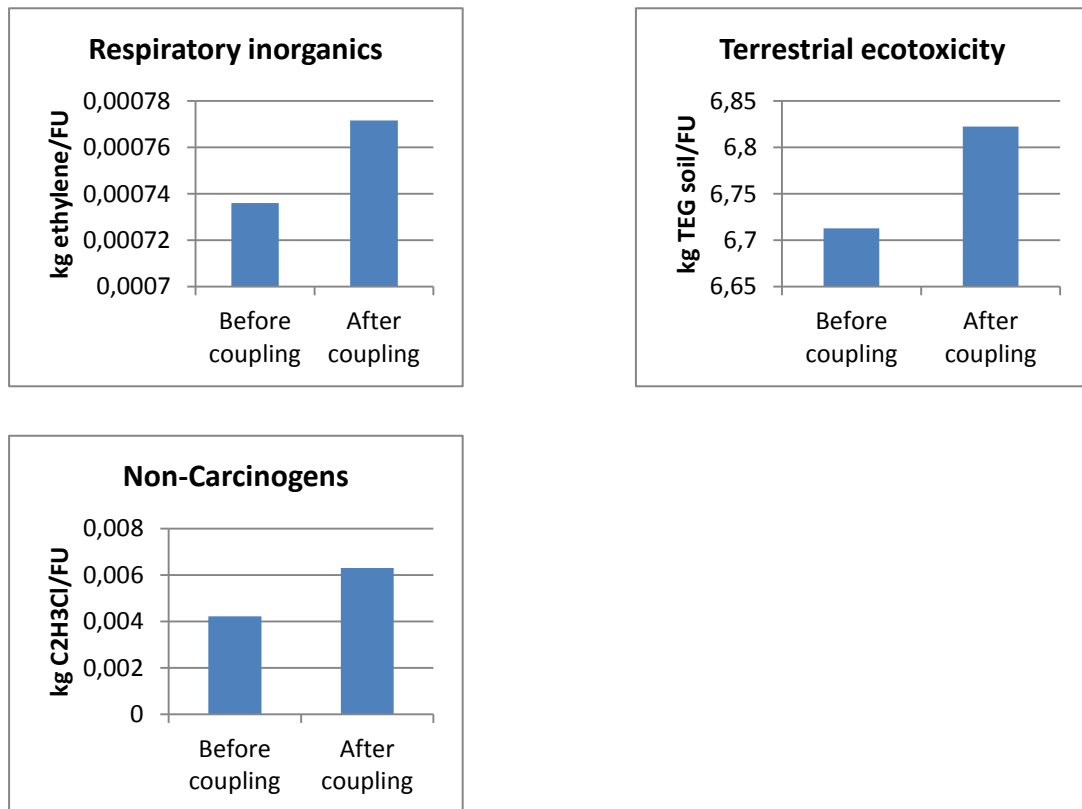

Figure 64 Comparison between midpoint impacts before and after coupling LCA/PSE (Used method: Impact 2002+)

For Global warming impacts, respiratory inorganics, and non-carcinogens/carcinogens categories, the relative difference between the results before and after the coupling is between 19.1% and 33.1% depending on the category. This means that before the coupling, the lack of precision and knowledge lead to an under-evaluation of environmental impacts. For categories i.e. respiratory inorganics, terrestrial acidification and terrestrial ecotoxicity, the impacts are slightly underestimated (4.6%, 5.1% and 1.6% respectively).

This significant difference is the origin for generation of additional data from the simulation and on the other hand, an updated data thanks to simulation. Additional objects of the type “Flow” are:

- Waste mixture of Methanol/water
- Jatropha oil that remain un-esterified

The objects of type “Flow” updated are:

- Hydrochloric acid
- Methanol
- Soda
- Potassium hydroxide

- Fatty acids
- Electricity
- Natural gas

In our case study, the results of the LCA without coupling are based on existing situation offers the opportunity to access field data in principle more representative than that of the simulated data. Thus, the results without coupling are less uncertain and more reliable. However, we limit ourselves to the case of an existing system. This is not always the case, especially in preliminary design phases of innovative processes. In this case, the field data are not available or available to very little extent; the simulation can improve the eco-design of system.

In the view of relative differences between 19.1% and 33.1% for four out of seven categories and between 1.6% and 5.1% for the three other categories, we consider here that the simulation gives a reliable order of magnitude of the environmental impacts of system during the preliminary design. Thus, the coupling of an LCA tool with a tool for process simulation finds its legitimacy in an eco-design approach.

Moreover, even in case of access to experimental data on an existing system, the use of coupling tools may be necessary for the sensitivity analysis. Indeed, precise knowledge of the process (vision “white box”) allows a fine variation for operating parameters linked with different stream of LCA through knowledge law of transformation. Thus, the study of the influence of a parameter or study of one flow on the other flows can be achieved.

#### 12.1.2 *Influence of conversion rate with two functional units (scenarios 2 & 3)*

Through detailed knowledge and the results of the simulation process, the process engineer reveals new information about the composition of the final biodiesel blend. In terms of exchange of objects (in Figure 48), he traces the existence of residual oil mixed with methyl ester (“Comment”), the quantity (“Variable”) with the rate of conversion and with its calorific value (“Variable”).

Results regarding impacts and their values are summarized in Table 41 and Table 42 of the appendixes 15.8. Figure 65 shows the same trend i.e. the impacts decrease as the conversion rate decreases for 1MJ production of biodiesel (methyl ester mixture and Jatropha oil). In contrast, the impact increases when the yield decreases for the production of 1MJ pure methyl ester (Jatropha Biodiesel).

This paradoxical phenomenon leads us to the idea where it is better not to carry out esterification and which can be explained by the respective calorific powers of the crude Jatropha oil and methyl ester. Indeed Jatropha oil is higher valued than that of the methyl ester in this regard. However, transesterification to transform crude oil into methyl ester, thus we move from a product with a calorific value slightly higher to the product with a slightly lower

calorific value. Finding like these raises the question of the definition of the functional unit to be used. The secondary functions are to be specified in order to justify the transesterification process. For example, it may be appropriate to define fuel quality associated with the mentioned functional unit. In fact, it is not certain that the two products, Jatropha oil and methyl ester, have the same behavior in the engine and that beyond a certain threshold, combustion problems arise.

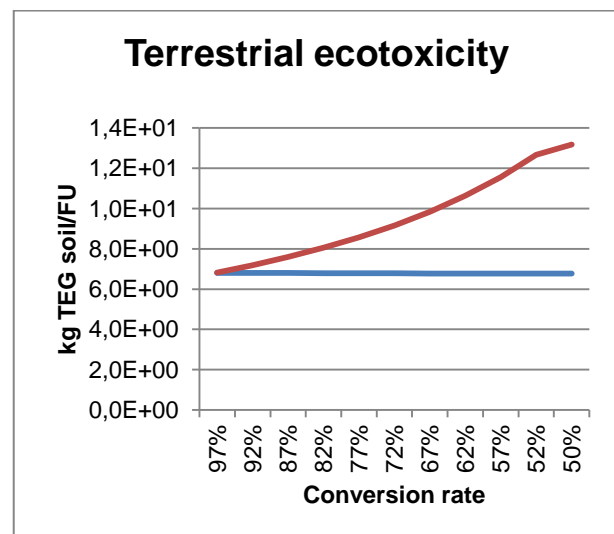
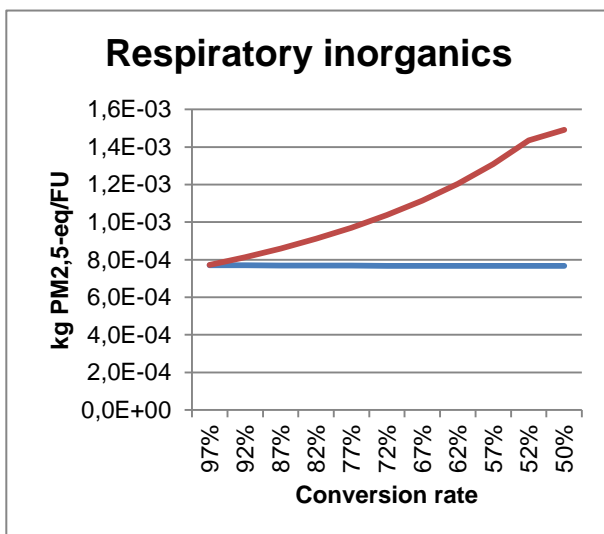
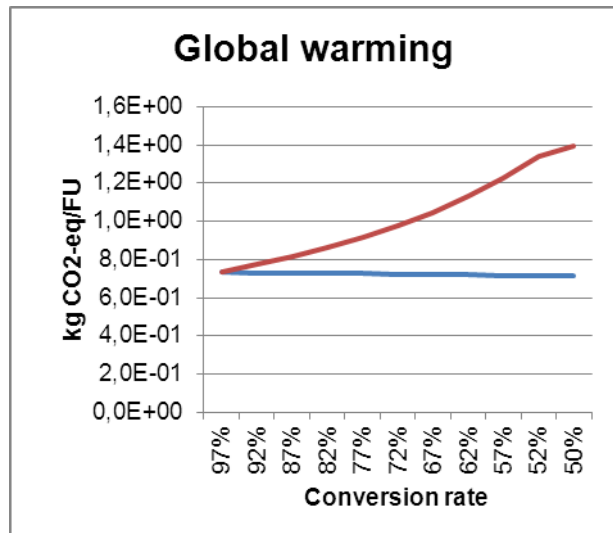
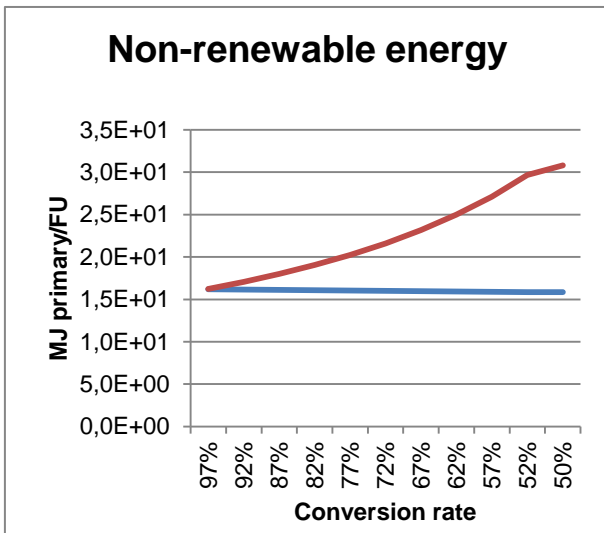

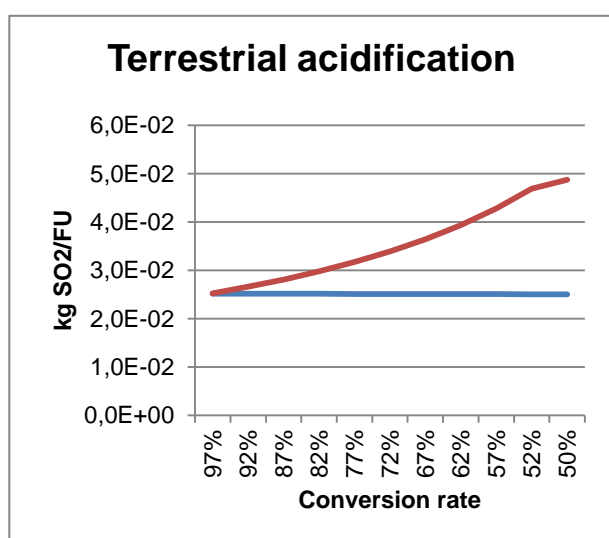
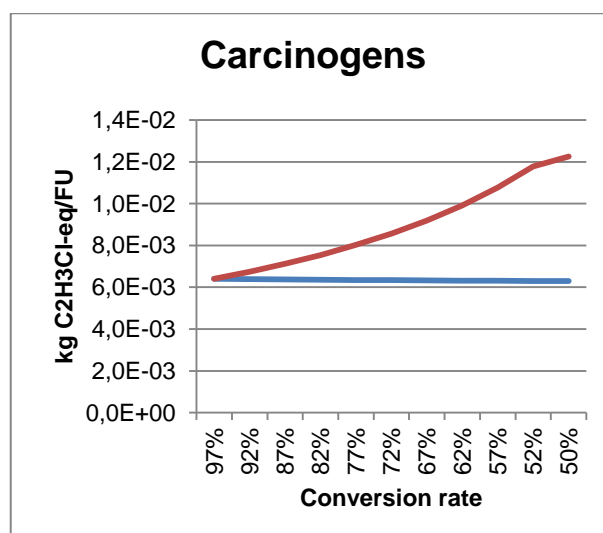
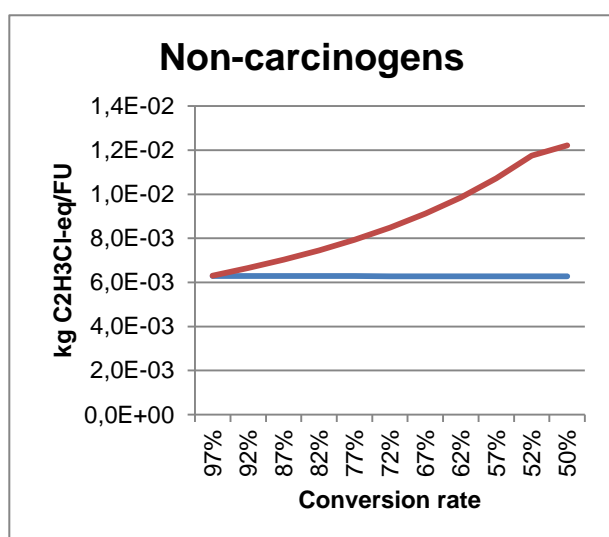

\_ MJ bio = Functional unit correspond to production of 1MJ pure methyl ester

\_ MJ tot = Functional unit correspond to 1 MJ of biodiesel (mixture of crude oil and methyl ester)

Figure 65 Comparison of midpoint impact (Impact 2002+) with respective dependence on FU

On the other hand, this similar trend for each impact category leads to the conclusion that the study of a single category may be sufficient to interpret the behavior of others and vice versa. This is due to the structure of LCA; where impact factors are fixed coefficients so they evaluate the inventory results in the same manner. Changes in inventory results are not necessarily linear for the rate of conversion (thermodynamic models) which gives a non-linear curve.

### 12.1.3 Influence of un-entertained impacts (scenarios 4 & 5)

Regarding the flow of glycerin with the coupling, the object of type "Flow" is associated with an object of type "Variable"; its value may vary depending on the object "Conversion rate". The possible impact results according to the two mentioned functional units (one depending upon the conversion rate and non-included impacts caused by production of glycerin) are summarized in Table 43 and Table 44 of appendixes 15.8. Table 46 provides complete analysis

by showing the relative difference between the results with or without the non-included impacts associated with glycerin. The difference is less than 0.5%, which leads to the conclusion that by either taking account or not the avoided impact due to the production of glycerin did not significantly affected the resulted conclusion of LCA study.

## 12.2 CONCLUSION THANKS TO SIMLCA TOOL

Relied on our framework for a product and process based environmental evaluation, we studied the influence of sub process parameters and outputs on the sustainability matrices.

To integrate such LCA methodology in the presence of PSE allows:

- i) On the industrial side, an eco-designing process optimization
- ii) On the society and end-users side, a process environmental performances dashboard

In terms of benefits, the proposed approach allows to formalize the coupling between different actors in the form of an exchange of information. Thus, through a coupling LCA-PSE, the objects exchanged our scenarios study allows:

- The study of influence of design parameters of process on the results for environmental analysis
- Qualitative and quantitative generation of data
- Validation of data used by the environment engineer through material balance and enthalpy.
- A systematic and rigorous study of materials and energy streams.
- Improvement in the knowledge of studied system: on quality, quantity and precision level.

This improved knowledge leads to increase the possible system configurations and combinations of these configurations, increasing the number of possible scenarios. The sensitivity study is improved and with its accuracy and relevance of course of action established by the environmental engineer to eco-design for system.

## 12.3 CRITICAL COMPARISON WITH OTHER STUDIES

In accordance to the present study there are other studies present in the literature which evaluates the environmental impact based on life cycle assessment. So Kaewcharoensombat et al., (2011) reported that the LCA was performed after process simulation to determine the environmental impact. The life cycle of biodiesel starts with raw material production, transportation, biodiesel production and finally fuel composition. They focused on three categories for damage assessment i.e., resources, human health and ecosystem quality. They too found biodiesel production stage (most impactful due to transesterification) contributed to

higher environmental impact compared to other stages. Related to GHG emission, Choo et al., (2011) conducted the LCA of biodiesel from palm oil. Their inventory analysis included nursery, plantation, palm oil mill, refinery, and biodiesel plant. Analysis was carried out at each stage to determine the amount of GHG emissions that it emitted. The results showed that GHG emissions occurred during the milling process from the use of fertilizer. Evidently, optimization is an excellent strategy that offers promising solutions for desirable conditions either in maximizing profit, minimizing waste or reducing environmental impact (Nasir et al., 2013).

With a brief review of literature it was found that there is a lack of studies that provides a dashboard for multi-criteria analysis of biofuel production process. Azapagic and Stichnothe, (2010) illustrated the need of multi-objective optimization inclusion for biofuel production processes. They also highlight the decision making philosophy for the production process in order to evaluate more sustainability options. Keeping all these in mind the present study provide the integration of LCA methodology in the presence of PSE methods and tools that allows us an eco-designing process optimization on the industrial side and on the society and end-users side, a process environmental performances dashboard. We have proposed a decision making process providing a guideline based on enterprise sustainability levels and which helps the process of chemical production chain to be performed efficiently in an industrial context which is always a missing point in those mentioned studies. This helps to fix operating conditions and to fix structural characteristics of the whole phenomena that too in industrial context. Through this research work we highlight the need of further assimilation of PSE with LCA and social LCA methodologies in order to serve the society and process industry to become more eco-friendly.





---

## PART FOUR

---

### D. POSTSCRIPT



---

This final part concludes the whole Ph.D along with future perspectives. It also provides the literatures that are cited during this research project. Further the details about different section that were not included in the main discussions are put here as appendixes. They are sorted in their respective section hereafter. Finally the index presents different abbreviations that are used in this manuscript.



---

## 13. Conclusion and Perspectives

---

This chapter sets the conclusion. The results and the main scientific contributions are outlined with related perspectives.

---

This work is the outcome of the first collaboration of LGC (Laboratoire de Génie Chimique, department “Procédés et Systèmes Industriels”), CNRS UMR 5503 and LCA (Laboratoire de Chimie Agro Industrielle, équipe «Impact environnemental systémique »), INRA UMR 1010 Université de Toulouse.

Among many approaches, the coupling of PSE and LCA is investigated as a good instrument to evaluate the environmental performance of different unitary processes and whole process. The main aim of this present theme is to propose a systematic approach for integrating life cycle assessment in process systems engineering, which will strengthen the ultimate consideration of the influence of the process parameters and its integration on the thermodynamic, kinetics and environmental life cycle performance in the early stages of process synthesis and designing. Our current proposal involves number of stakeholders with multiple and often conflicting objectives. We try to provide a multiple criteria decision support framework which helps to provide a systematic and step by step guidance to decision making for decision makers.

The present manuscript is built on four parts. First we start with presentation and findings of a literature review that focuses on LCA concepts, methods and tools. Literature on biofuels and its sustainability with a special focus on *Jatropha* biodiesel production is highlighted. This review also explores some broader aspects of sustainability, bioenergy, i.e. economic and political frameworks and biomass potential. We provide a short overview of process system engineering.

The second part deals with description of LCA method and a field study of *Jatropha curcas* L. We investigate the biodiesel production from an experimental site in western Africa (Mali) and thus deliver an advanced global model. We evaluate biodiesel for environmental analysis with the help of field data, background data (Ecoinvent 2.1) and impact methodologies (Impact 2002+ and CML 2). Through this environmental evaluation, we identify the hotspot in the whole production system. To complement the experimental data this hotspot (transesterification unitary process) is selected for simulation study.

The third part suggests a frame for a PSE based environmental analysis following a “PSE embedded LCA” approach. A three steps structuration (system, business process and agro-chemical process) involving five types of decision makers and a basic information model are formalized. On this basis we develop a modeling tool on MS Excel, called SimLCA, to integrate LCA and process simulation. The influence of parameters can be obtained on the sustainability matrices. The coupling within one single application allows an automatic updating sequence of results whenever there is a modification in the operating condition (conversion rate of the transesterification reaction, for example), and thus to deepen and refine the environmental analysis. From SimLCA application, we define different configurations of the whole (production) system and we analyze different scenarios.

---

Then research question mentioned in Part-A (5.2) was proposed to answer one by one given as below:

The first question was ***“What are the concepts and methods of engineering for industrial systems sustainability”?***

So to answer this question, the first point is the consideration of the life cycle thinking at each level of the system. The second point is the multi-disciplinary approach at the interface of multiple disciplines like environmental chemistry, chemical engineering, industrial and enterprise engineering. The third point is the proposal of an environmental or "sustainability" engineer as a leading character in the design of any systems.

The second question was ***“How to improve the current methodology of LCA for environmental evaluation”?***

To answer this question, first we have an improved environmental evaluation technique with the inclusion of process artifacts. Secondly for sustainability aspect we have a life cycle and process engineering integrated approach for decision making.

Third one was ***“What are the tools, methods and concepts that underlie the integration of environmental consideration in PSE”?***

So first we proposed the integration of LCT in process design. Secondly we have broadened the ways for development of dedicated tools for modeling and simulation of agro-industrial processes (such as SimLCA).

The fourth and last question was ***“What are the prospects for integrating LCA and PSE and the benefits of integrated framework”?***

We have proposed a framework which takes many stakeholders into account that is from systematic to a systemic one. Further we proposed an iterative and systemic approach for decision making to evaluate sustainability aspects of a system. Then a software prototype was developed which we named as SimLCA. SimLCA relies and carries the database from both LCA and PSE.

Further the main scientific contributions are highlighted hereafter:

- A life cycle and process engineering integrated approach for decision making in sustainability aspect.
- A multi-disciplinary work at the interface of several disciplines: environmental chemistry, chemical engineering, industrial and enterprise engineering
- A complete review of biofuel, LCA method and PSE-LCA coupling
- The LCA study of a real case with field experimentation; biodiesel production system from *Jatropha curcas* L.

- An improved environmental evaluation technique with the inclusion of process artifacts
- A framework that takes into accounts the different scales of the system (system level, business process level and agro-chemical process level) and the different stakeholders (system engineer, environment engineer, chemical process engineer, project manager and supply chain engineer)
- A top-down decomposition approach for black-grey-white boxes “on demand”
- An iterative process based on top-down and bottom-up flow of information for environment oriented decision making
- The proposal for an environment (or sustainability) engineer as a head in the design of any system
- The development of a software tool, SimLCA, based on databases and models

For future perspectives the following key points are highlighted through this research project:

- ✓ The integration of LCA methodology in the presence of PSE methods and tools allows eco-designing, process optimization on the industrial side and environmental performances dashboard on the society and end-users side. Additional indicators, impacts calculation methods and databases special for agro-chemical processes should be developed.
- ✓ SimLCA and its further integration for a production system characterize the knowledge and management of data generation and validation.
- ✓ The application of mathematical programming in the synthesis and planning of sustainable agro-chemical process should also be attempted. The work may focus on establishing environmental improvements through process synthesis and supply chain management by employing optimization, multi objective optimization and uncertainty analysis.
- ✓ We also highlight the need of further assimilation of PSE with social LCA methodologies in order to serve the society and process industry to become more eco-friendly. The future steps are especially important to integrate economic and social variables to current framework and to open the optimization option in sustainability.
- ✓ Another perspective is the development of super innovated structures of biodiesel production processes that include energy integration and comparing its



sustainability. It may then be considered as functions of economy and energy as both are related to profit.

- ✓ The development of a software tool, SimLCA, based on databases and models is a way forward for an innovated and more generic tool for environmental consideration of product-process.
- ✓ This study highlights and identifies relevant sustainability criteria and how to use the obtained information decision making process in response to the needs and requirements of sustainable growth. Therefore formalization of decision making process in a complete system can be acquired.



---

## 14. Bibliography

---

Literatures cited in this study are listed here.

- Abiola, A., Fraga, E.S., Lettieri, P., 2010. Multi-Objective Design for the Consequential Life Cycle Assessment of Corn Ethanol Production, in: S. Pierucci and G. Buzzi Ferraris (Ed.), *Computer Aided Chemical Engineering*. Elsevier, pp. 1309–1314.
- Achten, W., Almeida, J., Fobelets, V., Bolle, E., Mathijs, E., Singh, V.P., Tewari, D.N., Verchot, L.V., Muys, B., 2010. Life cycle assessment of Jatropha biodiesel as transportation fuel in rural India. *Applied Energy* 87, 3652–3660.
- Achten, W.M.J., Maes, W.H., Aerts, R., Verchot, L., Trabucco, A., Mathijs, E., Singh, V.P., Muys, B., 2010a. Jatropha: From global hype to local opportunity. *Journal of Arid Environments* 74, 164–165.
- Achten, W.M.J., Maes, W.H., Reubens, B., Mathijs, E., Singh, V.P., Verchot, L., Muys, B., 2010b. Biomass production and allocation in *Jatropha curcas* L. seedlings under different levels of drought stress. *Biomass and Bioenergy* 34, 667–676.
- Achten, W.M.J., Verchot, L., Franken, Y.J., Mathijs, E., Singh, V.P., Aerts, R., Muys, B., 2008. Jatropha bio-diesel production and use. *Biomass and Bioenergy* 32, 1063–1084.
- ADEME, 2013. Agence de l'Environnement et de la Maîtrise de l'Energie [WWW Document]. URL <http://www2.ademe.fr/>
- Adriaans, T., 2006. Suitability of solvent extraction for *Jatropha curcas*.
- Aksoy, M.A., Ng, F., 2010. The evolution of agricultural trade flows. World Bank.
- Alexander, B., Barton, G., Petrie, J., Romagnoli, J., 2000. Process synthesis and optimisation tools for environmental design: methodology and structure. *Computers & Chemical Engineering* 24, 1195–1200.
- Alonso, J.C., Dose, J., Fleischer, G., Geraghty, K., Greif, A., Rodrigo, J., Schmidt, W.-P., 2007. Electrical and electronic components in the automotive sector: Economic and environmental assessment. *Int J Life Cycle Assess* 12, 328–335.
- Ariza-Montobbio, P., Lele, S., 2010. Jatropha plantations for biodiesel in Tamil Nadu, India: Viability, livelihood trade-offs, and latent conflict. *Ecological Economics* 70, 189–195.
- Arvanitoyannis, I.S., 2008. Waste management for the food industries. Academic Press.
- Asakuma, Y., Maeda, K., Kuramochi, H., Fukui, K., 2009. Theoretical study of the transesterification of triglycerides to biodiesel fuel. *Fuel* 88, 786–791.
- Ayres, R.U., Ayres, L.W., 2002. *A handbook of industrial ecology*. Edward Elgar Publishing.
- Azapagic, A., 1999. Life cycle assessment and its application to process selection, design and optimisation. *Chemical Engineering Journal* 73, 1–21.
- Azapagic, A., Clift, R., 1999a. The application of life cycle assessment to process optimisation. *Computers & Chemical Engineering* 23, 1509–1526.
- Azapagic, A., Clift, R., 1999b. Life cycle assessment and multiobjective optimisation. *Journal of Cleaner Production* 7, 135–143.
- Azapagic, A., Millington, A., Collett, A., 2006. A Methodology for Integrating Sustainability Considerations into Process Design. *Chemical Engineering Research and Design* 84, 439–452.
- Azapagic, A., Perdan, S., 2005. An integrated sustainability decision-support framework Part II: Problem analysis. *The International Journal of Sustainable Development & World Ecology* 12, 112–131.
- Azapagic, A., Stichnothe, H., 2010. Sustainability Assessment of Biofuels, in: Azapagic, A., Perdan, S. (Eds.), *Sustainable Development in Practice*. John Wiley & Sons, Ltd, Chichester, UK, pp. 142–169.
- Ballerini, D., 2006. *Les biocarburants: état des lieux, perspectives et enjeux du développement*. Editions OPHRYS.

- Baral, A., Bakshi, B.R., 2010. Emergy analysis using US economic input–output models with applications to life cycles of gasoline and corn ethanol. *Ecological Modelling* 221, 1807–1818.
- Bare, J.C., 2002. Traci. *Journal of Industrial Ecology* 6, 49–78.
- Bare, J.C., 2002. Developing a consistent decision-making framework by using the US EPA's TRACI. Systems Analysis Branch, Sustainable Technology Division, National Risk Management Research Laboratory, US Environmental Protection Agency, Cincinnati, OH. Retrieved November 4, 2009.
- Bare, J.C., Gloria, T.P., 2006. Critical Analysis of the Mathematical Relationships and Comprehensiveness of Life Cycle Impact Assessment Approaches. *Environ. Sci. Technol.* 40, 1104–1113.
- Baumert, K.A., Herzog, T., Pershing, J., 2005. Navigating the numbers: Greenhouse gases and international climate change agreements.
- Bengtsson, M., Steen, B., 2000. Weighting in LCA – approaches and applications. *Environmental Progress* 19, 101–109.
- Berchmans, H.J., Morishita, K., Takarada, T., 2013. Kinetic study of hydroxide-catalyzed methanolysis of *Jatropha curcas*–waste food oil mixture for biodiesel production. *Fuel* 104, 46–52.
- Berkhout, F., Howes, R., 1997. The adoption of life-cycle approaches by industry: patterns and impacts. *Resources, Conservation and Recycling* 20, 71–94.
- Bessou, C., Ferchaud, F., Gabrielle, B., Mary, B., 2009. Biofuels, greenhouse gases and climate change. A review. *Agronomy for sustainable development* 31, 1–79.
- Bessou, C., Ferchaud, F., Gabrielle, B., Mary, B., 2011. Biofuels, Greenhouse Gases and Climate Change, in: Lichtfouse, E., Hamelin, M., Navarrete, M., Debaeke, P. (Eds.), *Sustainable Agriculture Volume 2*. Springer Netherlands, pp. 365–468.
- Bochu, J.L., 2007. Synthèse 2006 des bilans PLANETE.
- Breslow, R., Tirrell, M.V., Barton, J.K., Barteau, M.A., Bertozzi, C.R., Brown, R.A., Gast, A.P., Grossmann, I.E., Meyer, J.M., Murray, R.W., 2003. Beyond the molecular frontier: Challenges for chemistry and chemical engineering. National Research Academies Press, Washington.
- Bruinsma, J., 2003. *World Agriculture: Towards 2015/2030 ; an Fao Perspective*. Earthscan.
- Brunner, P.H., Rechberger, H., 2004. Practical handbook of material flow analysis. *The International Journal of Life Cycle Assessment* 9, 337–338.
- Burgess, A.A., Brennan, D.J., 2001. Application of life cycle assessment to chemical processes. *Chemical Engineering Science* 56, 2589–2604.
- Calow, P.P., 2009. *Handbook of environmental risk assessment and management*. John Wiley & Sons.
- Carlson, R., Löfgren, G., Steen, B., 1995. SPINE, a relation database structure for life cycle assessment.
- Cavaletti, O., da Cunha, M.P., Junqueira, T.L., de Souza Dias, M.O., de Jesus, C.D.F., Mantelatto, P.E., 2011. Environmental and economic assessment of bioethanol, sugar and bioelectricity production from sugarcane. *Pres* 11 25, 1007–1012.
- Cerdan, C., Gazulla, C., Raugei, M., Martinez, E., Fullana-i-Palmer, P., 2009. Proposal for new quantitative eco-design indicators: a first case study. *Journal of Cleaner Production* 17, 1638–1643.
- Chang, A.-F., Liu, Y.A., 2010. Integrated Process Modeling and Product Design of Biodiesel Manufacturing. *Ind. Eng. Chem. Res.* 49, 1197–1213.

- Chauhan, B., Kumar, N., Cho, H., 2010. Performance and emission studies on an agriculture engine on neat *Jatropha* oil. *Journal of Mechanical Science and Technology* 24, 529–535.
- Cherubini, F., Bird, N.D., Cowie, A., Jungmeier, G., Schlamadinger, B., Woess-Gallasch, S., 2009. Energy- and greenhouse gas-based LCA of biofuel and bioenergy systems: Key issues, ranges and recommendations. *Resources, Conservation and Recycling* 53, 434–447.
- Chitra, P., Venkatachalam, P., Sampathrajan, A., 2005. Optimisation of experimental conditions for biodiesel production from alkali-catalysed transesterification of *Jatropha curcas* oil. *Energy for Sustainable Development* 9, 13–18.
- Choo, Y.M., Muhamad, H., Hashim, Z., Subramaniam, V., Pua, C.W., Tan, Y., 2011. Determination of GHG contributions by subsystems in the oil palm supply chain using the LCA approach. *The International Journal of Life Cycle Assessment* 16, 669–681.
- Consoli, F., 1993. *Guidelines for life-cycle assessment: a code of practice*, 1st ed, SETAC. Society of Environmental Toxicology and Chemistry (SETAC) Pensacola, FL.
- Cozier, M., 2010. Developing country farmland bought for biofuels. *Biofuels, Bio products and Biorefinery*.
- Crutzen, P.J., Mosier, A.R., Smith, K.A., Winiwarter, W., 2007. N<sub>2</sub>O release from agro-biofuel production negates global warming reduction by replacing fossil fuels. *Atmospheric Chemistry and Physics Discussions* 7, 11191–205.
- Curran, M.A., 2006. *Life-cycle Assessment: Principles and Practice*, Scientific Applications International Corporation, SAIC. National Risk Management Research Laboratory, Office of Research and Development, US Environmental Protection Agency.
- Demirbas, A., 2007. Progress and recent trends in biofuels. *Progress in energy and combustion science* 33, 1–18.
- Demirbas, A., 2008. Comparison of transesterification methods for production of biodiesel from vegetable oils and fats. *Energy Convers. Manag.* 49, 125–130.
- Demirbas, A., 2009. Progress and recent trends in biodiesel fuels. *Energy Conversion and Management* 50, 14–34.
- Di Nicola, G., Moglie, M., Pacetti, M., Santori, G., 2010. Bioenergy II: Modeling and Multi-Objective Optimization of Different Biodiesel Production Processes. *International Journal of Chemical Reactor Engineering* 8.
- Dias, L.A.S., Leme, L.P., Laviola, B.G., Pallini Filho, A., Pereira, O.L., Carvalho, M., Manfio, C.E., Santos, A.S., Sousa, L.C.A., Oliveira, T.S., others, 2007. Cultivo de pinhão-manso (*Jatropha curcas* L.) para produção de óleo combustível. *Vilçosa, MG* 1, 1–40.
- Ekvall, T., Tillman, A.-M., Molander, S., 2005. Normative ethics and methodology for life cycle assessment. *Journal of Cleaner Production* 13, 1225–1234.
- Ekvall, T., Weidema, B.P., 2004. System boundaries and input data in consequential life cycle inventory analysis. *The International Journal of Life Cycle Assessment* 9, 161–171.
- Elms, R.D., El-Halwagi, M.M., 2010. The effect of greenhouse gas policy on the design and scheduling of biodiesel plants with multiple feedstocks. *Clean Techn Environ Policy* 12, 547–560.
- European Commission, 2007. *European reference Life-Cycle Database (ELCD 3.0)* [WWW Document]. URL <http://elcd.jrc.ec.europa.eu/ELCD3/> (accessed 7.4.13).
- Farrell, A.E., Plevin, R.J., Turner, B.T., Jones, A.D., O'Hare, M., Kammen, D.M., 2006. Ethanol Can Contribute to Energy and Environmental Goals. *Science* 311, 506–508.
- Finnveden, G., Hauschild, M.Z., Ekvall, T., Guinee, J., Heijungs, R., Hellweg, S., Koehler, A., Pennington, D., Suh, S., 2009. Recent developments in life cycle assessment. *Journal of environmental management* 91, 1–21.

- Francis, G., Edinger, R., Becker, K., 2005. A concept for simultaneous wasteland reclamation, fuel production, and socio-economic development in degraded areas in India: need, potential and perspectives of *Jatropha* plantations, in: *Natural Resources Forum*. pp. 12–24.
- Fulton, L., Howes, T., Hardy, J., 2004. *Biofuels for transport: an international perspective*. OECD, International Energy Agency Paris.
- García, M., Gonzalo, A., Sánchez, J.L., Arauzo, J., Peña, J.Á., 2010. Prediction of normalized biodiesel properties by simulation of multiple feedstock blends. *Bioresource Technology* 101, 4431–4439.
- Gasafi, E., Meyer, L., Schebek, L., 2003. Using Life-Cycle Assessment in Process Design. *Journal of Industrial Ecology* 7, 75–91.
- Gerpen, J.V., 2005. Biodiesel processing and production. *Fuel Processing Technology* 86, 1097–1107.
- Gillani, S. T., J. P. Belaud, C. Sablayrolles, M. Vignoles, and J. M. Le Lann., 2013 “A CAPE Based Life Cycle Assessment for Evaluating the Environmental Performance of Non-Food Agro-Processes.” In *Chemical Engineering Transactions, AIDIC*, 32:211–216.
- Gillani, S.T., Belaud, J.P., Sablayrolles, C., Vignoles, M., Le Lann, J.M., 2012. Development in present case study of Life Cycle Assessment for *Jatropha* biodiesel, RRB-8, Eighth International Conference on Renewable Resources and Biorefineries, Toulouse, 4 - 6 June, 2012.
- Gillani, S., Sablayrolles, C., Belaud, J.-P., Montrejaud-Vignoles, M., Marc Le Lann, J., 2011a. Assessment of *Jatropha curcas* bioprocess for fuel production using LCA and CAPE, in: 21st European Symposium on Computer Aided Process Engineering. Elsevier, 29. 1341–1345.
- Gillani, S. T., J. P. Belaud, C. Sablayrolles, M. Vignoles, and J. M. Le Lann., 2011b. Environmental assessment of bioprocess for biofuel production, *Récents Progrès en Génie des Procédés*, Numéro 101 – 2011, Ed. SFGP, Paris, France.
- Gillani, S.T., Belaud, J.-P., Sablayrolles, C., Vignoles, M., Le Lann, J.-M., 2010. Review of Life Cycle Assessment in Agro-Chemical Processes," *Chemical Product and Process Modeling*: Vol. 5 : Iss. 1, Article 33.
- Gmehling, J., Li, J., Schiller, M., 1993. A modified UNIFAC model. 2. Present parameter matrix and results for different thermodynamic properties. *Industrial & Engineering Chemistry Research* 32, 178–193.
- Goedkoop, M., Heijungs, R., Huijbregts, M., De Schryver, A., Struijs, J., Van Zelm, R., 2009. *ReCiPe 2008*.
- Goedkoop, M., Oele, M., de Schryver, A., Vieira, M., 2008. *SimaPro database manual*.
- Goedkoop, M., Spriensma, R., 2001. *Eco-indicator 99 impact assessment method for LCA* | PRé Consultants.
- Goodrum, J.W., Geller, D.P., 2005. Influence of fatty acid methyl esters from hydroxylated vegetable oils on diesel fuel lubricity. *Bioresource Technology* 96, 851–855.
- Goumelon, S., Hêtreux, R., Floquet, P., Baudouin, O., Baudet, P., 2013. General procedure for the computation of exergy efficiency: a first step of a complete exergy analysis methodology within ProSimPlus® process simulation software, in: *Récents Progrès en Génie des Procédés*. Presented at the SFGP, Paris.
- Gour, V., 2006. Production practices including post-harvest management of *Jatropha curcas*, in: *Biodiesel Conference Towards Energy Independence—Focus on Jatropha*. p. 223.
- Graboski, M.S., McCormick, R.L., 1998. Combustion of fat and vegetable oil derived fuels in diesel engines. *Progress in Energy and Combustion Science* 24, 125–164.

- Granados, M.L., Poves, M.D.Z., Alonso, D.M., Mariscal, R., Galisteo, F.C., Moreno-Tost, R., Santamaría, J., Fierro, J.L.G., 2007. Biodiesel from sunflower oil by using activated calcium oxide. *Applied Catalysis B: Environmental* 73, 317–326.
- Grossmann, I.E., 2003. Challenges in the new millennium: Product discovery and design, enterprise and supply chain optimization, global life cycle assessment, in: Bingzhen Chen and Arthur W. Westerberg (Ed.), *Computer Aided Chemical Engineering*. Elsevier, pp. 28–47.
- Grossmann, I.E., 2004. Challenges in the new millennium: product discovery and design, enterprise and supply chain optimization, global life cycle assessment. *Computers & Chemical Engineering* 29, 29–39.
- Grossmann, I.E., Westerberg, A.W., 2000. Research challenges in process systems engineering. *AIChE Journal* 46, 1700–1703.
- Guillen-Gosalbez, G., Caballero, J.A., Jimenez, L., 2008. Application of Life Cycle Assessment to the Structural Optimization of Process Flowsheets. *Ind. Eng. Chem. Res.* 47, 777–789.
- Guillén-Gosálbez, G., Grossmann, I., 2010. A global optimization strategy for the environmentally conscious design of chemical supply chains under uncertainty in the damage assessment model. *Computers & Chemical Engineering* 34, 42–58.
- Guinée, J.B., 2002. Handbook on life cycle assessment operational guide to the ISO standards. *The international journal of life cycle assessment* 7, 311–313.
- Guinée, J.B., Heijungs, R., Huppes, G., Zamagni, A., Masoni, P., Buonamici, R., Ekvall, T., Rydberg, T., 2011. Life Cycle Assessment: Past, Present, and Future†. *Environ. Sci. Technol.* 45, 90–96.
- Guinée, J.B., Udo de Haes, H.A., Huppes, G., 1993. Quantitative life cycle assessment of products: 1: Goal definition and inventory. *Journal of Cleaner Production* 1, 3–13.
- Gutowski, T.G., Sekulic, D.P., Bakshi, B.R., 2009. Preliminary thoughts on the application of thermodynamics to the development of sustainability criteria, in: *IEEE International Symposium on Sustainable Systems and Technology*. Presented at the ISSST 09, IEEE, pp. 1–6.
- Halim, I., Srinivasan, R., 2011. A knowledge-based simulation-optimization framework and system for sustainable process operations. *Computers & Chemical Engineering* 35, 92–105.
- Hansen, J., Kharecha, P., Sato, M., Ackerman, F., Hearty, P.J., Hoegh-Guldberg, O., Hsu, S.-L., Krueger, F., Parmesan, C., Rahmstorf, S., 2011. Scientific case for avoiding dangerous climate change to protect young people and nature. *arXiv preprint arXiv:1110.1365*.
- Hauschild, M.Z., Alting, L., 1997. *Environmental assessment of products: Volume 2: Scientific background*. Springer.
- Heijungs, R., Huppes, G., Guinée, J.B., 2010. Life cycle assessment and sustainability analysis of products, materials and technologies. Toward a scientific framework for sustainability life cycle analysis. *Polymer Degradation and Stability* 95, 422–428.
- Heller, J., 1996. *Physic Nut, Jatropha curcas L.* Bioversity international.
- Heller, M.C., Keoleian, G.A., Volk, T.A., 2003. Life cycle assessment of a willow bioenergy cropping system. *Biomass and Bioenergy* 25, 147–165.
- Himmel, M.E., Ding, S.-Y., Johnson, D.K., Adney, W.S., Nimlos, M.R., Brady, J.W., Foust, T.D., 2007. *Biomass Recalcitrance: Engineering Plants and Enzymes for Biofuels Production*. *Science* 315, 804–807.
- Hirao, M., Sugiyama, H., Fischer, U., Hungerbühler, K., 2008. IDEFO activity modeling for integrated process design considering environmental, health and safety (EHS) aspects, in: Bertrand Braunschweig and Xavier Julia (Ed.), *Computer Aided Chemical Engineering*. Elsevier, pp. 1065–1070.



- Hunt, S., 2006. Biofuels for Transportation. Worldwatch Institute.
- ISO, I., 2006. ISO - International Organization for Standardization [WWW Document]. URL [http://www.iso.org/iso/catalogue\\_detail?csnumber=37456](http://www.iso.org/iso/catalogue_detail?csnumber=37456) (accessed 3.13.12).
- Jacquemin, L., Pontalier, P.-Y., Sablayrolles, C., 2012. Life cycle assessment (LCA) applied to the process industry: a review. *The International Journal of Life Cycle Assessment* 1–14.
- Jain, S., Sharma, M.P., 2010. Kinetics of acid base catalyzed transesterification of *Jatropha curcas* oil. *Bioresource Technology* 101, 7701–7706.
- Johansson, J., Luttrupp, C., 2009. Material hygiene: improving recycling of WEEE demonstrated on dishwashers. *Journal of Cleaner Production* 17, 26–35.
- Jolliet, O., Margni, M., Charles, R., Humbert, S., Payet, J., Rebitzer, G., Rosenbaum, R., 2003. IMPACT 2002+: A new life cycle impact assessment methodology. *The International Journal of Life Cycle Assessment* 8, 324–330.
- Jolliet, O., Müller-Wenk, R., Bare, J., Brent, A., Goedkoop, M., Heijungs, R., Itsubo, N., Peña, C., Pennington, D., Potting, J., others, 2004. The LCIA midpoint-damage framework of the UNEP/SETAC life cycle initiative. *The International Journal of Life Cycle Assessment* 9, 394–404.
- Jolliet, O., Saadé, M., Crettaz, P., Shaked, S., 2010. Analyse du cycle de vie: comprendre et réaliser un écobilan. PPUR presses polytechniques.
- Kaewcharoensombat, U., Prommetta, K., Srinophakun, T., 2011. Life cycle assessment of biodiesel production from *jatropha*. *Journal of the Taiwan Institute of Chemical Engineers* 42, 454–462.
- Kaushik, N., Kumar, K., Kumar, S., Kaushik, N., Roy, S., 2007. Genetic variability and divergence studies in seed traits and oil content of *Jatropha* (*Jatropha curcas* L.) accessions. *Biomass and Bioenergy* 31, 497–502.
- Kim, S., Dale, B.E., 2002. Allocation procedure in ethanol production system from corn grain I. system expansion. *The International Journal of Life Cycle Assessment* 7, 237–243.
- Klatt, K.-U., Marquardt, W., 2009. Perspectives for process systems engineering—Personal views from academia and industry. *Computers & Chemical Engineering* 33, 536–550.
- Kniel, G.E., Delmarco, K., Petrie, J.G., 1996. Life cycle assessment applied to process design: Environmental and economic analysis and optimization of a nitric acid plant. *Environmental Progress* 15, 221–228.
- Kumar, A., Sharma, S., 2008. An evaluation of multipurpose oil seed crop for industrial uses (*Jatropha curcas* L.): A review. *Industrial crops and products* 28, 1–10.
- Kumar Tiwari, A., Kumar, A., Raheman, H., 2007. Biodiesel production from *jatropha* oil (*Jatropha curcas*) with high free fatty acids: An optimized process. *Biomass and Bioenergy* 31, 569–575.
- Kurk, F., Eagan, P., 2008. The value of adding design-for-the-environment to pollution prevention assistance options. *Journal of Cleaner Production* 16, 722–726.
- Lang, X., 2001. Preparation and characterization of bio-diesels from various bio-oils. *Bioresource Technology* 80, 53–62.
- Larson, E.D., 2006. A review of life-cycle analysis studies on liquid biofuel systems for the transport sector. *Energy for Sustainable Development* 10, 109–126.
- Leão, R.R. de C.C., Hamacher, S., Oliveira, F., 2011. Optimization of biodiesel supply chains based on small farmers: A case study in Brazil. *Bioresource Technology* 102, 8958–8963.
- Leduc, S., Natarajan, K., Dotzauer, E., McCallum, I., Obersteiner, M., 2009. Optimizing biodiesel production in India. *Applied Energy* 86, Supplement 1, S125–S131.

- Leung, D.Y.C., Wu, X., Leung, M.K.H., 2010. A review on biodiesel production using catalyzed transesterification. *Appl. Energy* 87, 1083–1095.
- Lichtfouse, E., Hamelin, M., Navarrete, M., 2011. *Sustainable Agriculture: Volume 2*. Springer.
- Lindfors, L.G., Christiansen, K., Hoffman, L., Virtanen, Y., Juntilla, V., Hanssen, O.J., Rønning, A., Ekvall, T., Finnveden, G., 1995. *Nord 1995: 20: Nordic guidelines on life-cycle assessment*.
- Liu, Y., Sotelo-Boyás, R., Murata, K., Minowa, T., Sakanishi, K., 2011. Hydrotreatment of Vegetable Oils to Produce Bio-Hydrogenated Diesel and Liquefied Petroleum Gas Fuel over Catalysts Containing Sulfided Ni–Mo and Solid Acids. *Energy Fuels* 25, 4675–4685.
- Lo, S.C., Ma, H., Lo, S.L., 2005. Quantifying and reducing uncertainty in life cycle assessment using the Bayesian Monte Carlo method. *Science of the total environment* 340, 23–33.
- Lu, H., Liu, Y., Zhou, H., Yang, Y., Chen, M., Liang, B., 2009. Production of biodiesel from *Jatropha curcas* L. oil. *Computers & Chemical Engineering* 33, 1091–1096.
- Lund Declaration, 2009. Europe must focus on the grand challenges of our time.
- Lundie, S., Huijbregts, M.A.J., Rowley, H.V., Mohr, N.J., Feitz, A.J., 2007. Australian characterisation factors and normalisation figures for human toxicity and ecotoxicity. *Journal of Cleaner Production* 15, 819–832.
- Ma, F., Hanna, M.A., 1999. Biodiesel production: a review. *Bioresource Technology* 70, 1–15.
- Makkar, H.P.S., Becker, K., 2009. *Jatropha curcas*, a promising crop for the generation of biodiesel and value-added coproducts. *European Journal of Lipid Science and Technology* 111, 773–787.
- Manuilova, A., Suebsiri, J., Wilson, M., 2009. Should Life Cycle Assessment be part of the Environmental Impact Assessment? Case study: EIA of CO<sub>2</sub> Capture and Storage in Canada. *Energy Procedia* 1, 4511–4518.
- Marquardt, W., 1999. From process simulation to lifecycle modeling. *Chemie-Ingenieur-Technik* 71, 1119–1137.
- Martinez, D., Kafarov, V., 2012. Computer aided estimation of sustainability of biodiesel production from palm oil., in: Ian David Lockhart Bogle and Michael Fairweather (Ed.), *Computer Aided Chemical Engineering*. Elsevier, pp. 222–226.
- Martinot, E., Sawin, J., 2009. *Renewables global status report: 2009 update*.
- Miettinen, P., Hämäläinen, R.P., 1997. How to benefit from decision analysis in environmental life cycle assessment (LCA). *European Journal of Operational Research* 102, 279–294.
- Mishra, D., 2009. Selection of candidate plus phenotypes of *Jatropha curcas* L. using method of paired comparisons. *Biomass and Bioenergy* 33, 542–545.
- Möller, D.R., 2006. Cell wall saccharification: outputs from the EPOBIO project. CPL.
- Möller, R., Pauly, M., Hake, S., Bowles, D., 2007. Crop platforms for cell wall saccharification: lignocellulose feedstock, Outputs from the EPOBIO project.
- Morales-Mendoza, L.F., Azzaro-Pantel, C., Belaud, J.-P., Pibouleau, L., Domenech, S., 2012. An integrated approach combining process simulation and life cycle assessment for eco-efficient process design, in: Ian David Lockhart Bogle and Michael Fairweather (Ed.), *Computer Aided Chemical Engineering*. Elsevier, pp. 142–146.
- Moras, S., 2007. Analyse comparée du cycle de vie des filières de production d'énergie renouvelable issue de la biomasse.
- Myint, L.L., El-Halwagi, M.M., 2009. Process analysis and optimization of biodiesel production from soybean oil. *Clean Techn Environ Policy* 11, 263–276.
- Narita, N., Nakahara, Y., Morimoto, M., Aoki, R., Suda, S., 2004. Current LCA database development in Japan -results of the LCA project. *Int J LCA* 9, 355–359.

- Nasir, N.F., Daud, W.R.W., Kamarudin, S.K., Yaakob, Z., 2013. Process system engineering in biodiesel production: A review. *Renewable and Sustainable Energy Reviews* 22, 631–639.
- Ndong, R., Vignoles, M., Olivier, S.T., Gabrielle, B., Pirot, R., Domergue, M., Sablayrolles, C., 2009. Life cycle assessment of biofuels from *Jatropha curcas* in West Africa: a field study. *GCB Bioenergy* 1, 197–210.
- Nguyena, T., Kikuchia, Y., Nodab, M., Sugiyamac, H., Hiraoa, M., 2010. Design and Assessment of Bio-Ethanol Based Chemical Process for Sustainability.
- NREL, 2004. NREL: U.S. Life Cycle Inventory Database Home Page [WWW Document]. URL <http://www.nrel.gov/lci/> (accessed 7.4.13).
- Oliveira de, J.S., Leite, P.M., de Souza, L.B., Mello, V.M., Silva, E.C., Rubim, J.C., Meneghetti, S.M.P., Suarez, P.A.Z., 2009. Characteristics and composition of *Jatropha gossypifolia* and *Jatropha curcas* L. oils and application for biodiesel production. *Biomass and Bioenergy* 33, 449–453.
- Olsen, S.I., Christensen, F.M., Hauschild, M., Pedersen, F., Larsen, H.F., Tørsløv, J., 2001. Life cycle impact assessment and risk assessment of chemicals — a methodological comparison. *Environmental Impact Assessment Review* 21, 385–404.
- Om Tapanes, N.C., Gomes Aranda, D.A., de Mesquita Carneiro, J.W., Ceva Antunes, O.A., 2008. Transesterification of *Jatropha curcas* oil glycerides: Theoretical and experimental studies of biodiesel reaction. *Fuel* 87, 2286–2295.
- Openshaw, K., 2000. A review of *Jatropha curcas*: an oil plant of unfulfilled promise. *Biomass and Bioenergy* 19, 1–15.
- Ortiz, O., Castells, F., Sonnemann, G., 2009. Sustainability in the construction industry: A review of recent developments based on LCA. *Construction and Building Materials* 23, 28–39.
- Ou, X., Zhang, X., Chang, S., Guo, Q., 2009. Energy consumption and GHG emissions of six biofuel pathways by LCA in (the) People's Republic of China. *Applied Energy* 86, S197–S208.
- Pachauri, R.K., 2008. Climate change 2007. Synthesis report. Contribution of Working Groups I, II and III to the fourth assessment report.
- Pandey, V.C., Singh, K., Singh, J.S., Kumar, A., Singh, B., Singh, R.P., 2012. *Jatropha curcas*: A potential biofuel plant for sustainable environmental development. *Renewable and Sustainable Energy Reviews* 16, 2870–2883.
- Pandey, Krishan K., Namita Pragma, and P.K. Sahoo. "Life Cycle Assessment of Small-scale High-input *Jatropha* Biodiesel Production in India." *Applied Energy* 88, no. 12 (December 2011): 4831–4839.
- Parikka, M., 2004. Global biomass fuel resources. *Biomass and Bioenergy* 27, 613–620.
- PE International, 2007. GaBi 4 Software-system and databases for life cycle engineering.
- Pearce, D., Atkinson, G., Mourato, S., 2006. Cost-benefit analysis and the environment: recent developments.
- Pennington, D., Potting, J., Finnveden, G., Lindeijer, E., Jolliet, O., Rydberg, T., Rebitzer, G., 2004. Life cycle assessment Part 2: Current impact assessment practice. *Environment International* 30, 721–739.
- Pennington, D.W., Rydberg, T., 2005. Life Cycle Assessment, in: *Encyclopedia of Toxicology* (Second Edition). Elsevier, New York, pp. 715–719.
- Portha, J.-F., Louret, S., Pons, M.-N., Jaubert, J.-N., 2010. Estimation of the environmental impact of a petrochemical process using coupled LCA and exergy analysis. *Resources, Conservation and Recycling* 54, 291–298.
- PRé Consultant, 1990. SimaPro [WWW Document]. URL <http://www.pre-sustainability.com/SimaPro-lca-software> (accessed 7.4.13).

- ProSim, 2012. Unité de production de biocarburant, Rapport d'Application ProsimPlus, 2012
- Prueksakorn, K., Gheewala, S.H., 2008. Full Chain Energy Analysis of Biodiesel from *Jatropha curcas* L. in Thailand. *Environ. Sci. Technol.* 42, 3388–3393.
- Prueksakorn, K., Gheewala, S.H., Malakul, P., Bonnet, S., 2010. Energy analysis of *Jatropha* plantation systems for biodiesel production in Thailand. *Energy for Sustainable Development* 14, 1–5.
- Quintero, J.A., Montoya, M.I., Sánchez, O.J., Giraldo, O.H., Cardona, C.A., 2008. Fuel ethanol production from sugarcane and corn: Comparative analysis for a Colombian case. *Energy* 33, 385–399.
- Quirin, M., Gärtner, S.O., Pehnt, M., Reinhardt, G., 2004. CO<sub>2</sub> mitigation through biofuels in the transport sector.
- Radich, A., 2004. Biodiesel performance, costs, and use.
- Raju, A.S., Ezradanam, V., 2002. Pollination ecology and fruiting behaviour in a monoecious species *Jatropha curcas* L.(Euphorbiaceae). *Current Science Bangalore* 83, 1395–1397.
- Ranganathan, S.V., Narasimhan, S.L., Muthukumar, K., 2008. An overview of enzymatic production of biodiesel. *Bioresource Technology* 99, 3975–3981.
- Rao, Y.V.H., Voleti, R.S., Raju, A.V.S., Reddy, P.N., 2009. Experimental Investigations on *Jatropha* Biodiesel and Additive in Diesel Engine. *Indian Journal of Science and Technology* 2, 25–31.
- Rebitzer, G., Ekvall, T., Frischknecht, R., Hunkeler, D., Norris, G., Rydberg, T., Schmidt, W.P., Suh, S., Weidema, B., Pennington, D., 2004. Life cycle assessment:: Part 1: Framework, goal and scope definition, inventory analysis, and applications. *Environment international* 30, 701–720.
- Reinhardt, G., Rettenmaier, N., Köppen, S., 2008. How sustainable are biofuels for transportation, in: *Bioenergy: Challenges and Opportunities*. International Conference and Exhibition on Bioenergy.
- Renner, A., Zelt, T., Gerteiser, S., 2008. Global Market Study on *Jatropha*. Final Report Prepared for the World Wildlife Fund for Nature (WWF). GEXSI, London.
- Ritthoff, M., Rohn, H., Liedtke, C., 2002. Calculating MIPS: Resource productivity of products and services. *Wuppertal Spezial*, Wuppertal Institut für Klima, Umwelt und Energie.
- Roy, P., Nei, D., Orikasa, T., Xu, Q., Okadome, H., Nakamura, N., Shiina, T., 2009. A review of life cycle assessment (LCA) on some food products. *Journal of Food Engineering* 90, 1–10.
- Rutz, D., Janssen, R., 2007. BioFuel SWOT-Analysis. *WIP Renewable Energies–2007* 1.
- Sahoo, P.K., Das, L.M., 2009. Process optimization for biodiesel production from *Jatropha*, *Karanja* and *Polanga* oils. *Fuel* 88, 1588–1594.
- San José Alonso, J.F., López Sastre, J.A., Romero-Ávila, C., Romero-Ávila, E.L., Izquierdo Iglesias, C., 2005. Using mixtures of diesel and sunflower oil as fuel for heating purposes in Castilla y León. *Energy* 30, 573–582.
- Sandén, B.A., Karlström, M., 2007. Positive and negative feedback in consequential life-cycle assessment. *Journal of Cleaner Production* 15, 1469–1481.
- Searchinger, T., Heimlich, R., Houghton, R.A., Dong, F., Elobeid, A., Fabiosa, J., Tokgoz, S., Hayes, D., Yu, T.-H., 2008. Use of U.S. Croplands for Biofuels Increases Greenhouse Gases Through Emissions from Land-Use Change. *Science* 319, 1238–1240.
- Shah, S., Sharma, A., Gupta, M.N., 2005. Extraction of oil from *Jatropha curcas* L. seed kernels by combination of ultrasonication and aqueous enzymatic oil extraction. *Bioresource Technology* 96, 121–123.

- Shanker, C., Dhyani, S., others, 2006. Insect pests of *Jatropha curcas* L. and the potential for their management. *Current Science* 91, 162–163.
- Sheehan, J., Camobreco, V., Duffield, J., Graboski, M., Shapouri, H., 1998. Life cycle inventory of biodiesel and petroleum diesel for use in an urban bus. Final report.
- Sikdar, S.K., 2003. Sustainable development and sustainability metrics. *AIChE Journal* 49, 1928–1932.
- Sotoft, L.F., Rong, B.-G., Christensen, K.V., Norddahl, B., 2010. Process simulation and economical evaluation of enzymatic biodiesel production plant. *Bioresource Technology* 101, 5266–5274.
- Srinivasan, S.P., Malliga, P., 2010. A new approach of adaptive Neuro Fuzzy Inference System (ANFIS) modeling for yield prediction in the supply chain of *Jatropha*, in: 2010 IEEE 17Th International Conference on Industrial Engineering and Engineering Management (IE EM). Presented at the 2010 IEEE 17Th International Conference on Industrial Engineering and Engineering Management (IE EM), pp. 1249–1253.
- Stewart, M., Weidema, B.P., 2004. A Consistent Framework for Assessing the Impacts from Resource Use - A focus on resource functionality (8 pp). *The International Journal of Life Cycle Assessment* 10, 240–247.
- Sumner, D.A., Tangermann, S., 2002. Chapter 38 International trade policy and negotiations, in: Bruce L. Gardner and Gordon C. Rausser (Ed.), *Handbook of Agricultural Economics*. Elsevier, pp. 1999–2055.
- Sunder, S., 2006. *Jatropha curcas* for biodiesel, organic farming and health. JV Publishing House, India.
- Susan, S., 2007. *Climate change 2007-the physical science basis: Working group I contribution to the fourth assessment report of the IPCC*. Cambridge University Press.
- Szargut, J., 2005. *Exergy method: technical and ecological applications*. WIT press.
- Tang, Z., Wang, L., Yang, J., 2007. Transesterification of the crude *Jatropha curcas* L. oil catalyzed by micro-NaOH in supercritical and subcritical methanol. *European Journal of Lipid Science and Technology* 109, 585–590.
- Tapasvi, D., Wiesenborn, D., Gustafson, C., 2004. Process modeling approach for evaluating the economic feasibility of biodiesel production, in: *The Society for Engineering in Agricultural, Food and Biological Systems*. pp. 1–16.
- Taylor, B., Hutchinson, C., Pollack, S., Tapper, R., 1994. *The environmental management handbook*. p. xxv + 486 pp.
- Tharumarajah, A., Grant, T., 2006. Australian National Life Cycle Inventory Database: Moving Forward, in: *Proceedings of the 5 Th ALCAS Conference, Melbourne, Australia*.
- Themelis, N.J., Ulloa, P.A., 2007. Methane generation in landfills. *Renewable Energy* 32, 1243–1257.
- UBA, 2007. ProBas - Zum ProBas-Projekt [WWW Document]. URL <http://www.probas.umweltbundesamt.de/php/index.php> (accessed 7.4.13).
- Udo de Haes, H.A., Lindeijer, E., 2002. The conceptual structure of life-cycle impact assessment. *Life-Cycle Impact Assessment: Striving Towards Best Practice* 209–225.
- Van der Drift, A., Boerrigter, H., 2006. Synthesis gas from biomass for fuels and chemicals. ECN Biomass, Coal and Environmental Research.
- Vlysidis, A., Binns, M., Webb, C., Theodoropoulos, C., 2011. Integrated Biodiesel Plants: Options and Perspectives, in: *Chemical Engineering Transactions*. pp. 1007–1012.

- Von Blottnitz, H., Curran, M.A., 2007. A review of assessments conducted on bio-ethanol as a transportation fuel from a net energy, greenhouse gas, and environmental life cycle perspective. *Journal of Cleaner Production* 15, 607–619.
- Vyas, A.P., Subrahmanyam, N., Patel, P.A., 2009. Production of biodiesel through transesterification of *Jatropha* oil using  $\text{KNO}_3/\text{Al}_2\text{O}_3$  solid catalyst. *Fuel* 88, 625–628.
- Wang, J.-X., HUANG, Q.-D., HUANG, F.-H., WANG, jiang-W., HUANG, Q.-J., 2007. Lipase-catalyzed Production of Biodiesel from High Acid Value Waste Oil Using Ultrasonic Assistant. *Chinese Journal of Biotechnology* 23, 1121–1128.
- Wang, Zanxin, Margaret M. Calderon, and Ying Lu. "Lifecycle Assessment of the Economic, Environmental and Energy Performance of *Jatropha curcas* L. Biodiesel in China." *Biomass and Bioenergy* 35, no. 7 (July 2011): 2893–2902.
- Weidema, B.P., Finnveden, G., Stewart, M., 2005. Impacts from Resource Use - A common position paper. *The International Journal of Life Cycle Assessment* 10, 382–382.
- Weidema, B.P., Wesnaes, M.S., 1996. Data quality management for life cycle inventories—an example of using data quality indicators. *Journal of Cleaner Production* 4, 167–174.
- Whitaker, M., Heath, G., (US), N.R.E.L., 2009. Life cycle assessment of the use of *Jatropha* biodiesel in Indian Locomotives. National Renewable Energy Laboratory.
- Winayanuwattikun, P., Kaewpiboon, C., Piriyananon, K., Tantong, S., Thakernkarnkit, W., Chulalaksananukul, W., Yongvanich, T., 2008. Potential plant oil feedstock for lipase-catalyzed biodiesel production in Thailand. *Biomass and Bioenergy* 32, 1279–1286.
- World Energy Outlook 2005: Middle East and North Africa Insights, 2005. . OECD Publishing.
- Young, P., Byrne, P.D.-I.G., Cotterell, M., 1997. Manufacturing and the environment. *Int J Adv Manuf Technol* 13, 488–493.
- Zah, R., Böni, H., Gauch, M., Hischier, R., Lehmann, M., Wäger, P., 2007. Life cycle assessment of energy products: environmental assessment of biofuels. Empa Technology and Society Lab. Bern, Switzerland.(Report produced under a contract from the Swiss Federal Office for Energy, the Swiss Federal Office for the Environment and the Swiss Federal Office for Agriculture) 19.
- Zeman, N., 2007. Shell partner to make hydrogen from glycerine. *Biomass Magazine* 1.
- Zhang, Y., Baral, A., Bakshi, B.R., 2010a. Accounting for Ecosystem Services in Life Cycle Assessment, Part II: Toward an Ecologically Based LCA. *Environ. Sci. Technol.* 44, 2624–2631.
- Zhang, Y., Dubé, M., McLean, D., Kates, M., 2003. Biodiesel production from waste cooking oil: 1. Process design and technological assessment. *Bioresource Technology* 89, 1–16.
- Zhang, Y., Singh, S., Bakshi, B.R., 2010b. Accounting for Ecosystem Services in Life Cycle Assessment, Part I: A Critical Review. *Environ. Sci. Technol.* 44, 2232–2242.
- ZHU, H., WU, Z., CHEN, Y., ZHANG, P., DUAN, S., LIU, X., MAO, Z., 2006. Preparation of Biodiesel Catalyzed by Solid Super Base of Calcium Oxide and Its Refining Process. *Chinese Journal of Catalysis* 27, 391–396.
- Zong, L., Ramanathan, S., Chen, C.-C., 2010. Predicting Thermophysical Properties of Mono- and Diglycerides with the Chemical Constituent Fragment Approach. *Ind. Eng. Chem. Res.* 49, 5479–5484.

---

CHAPTER

15

---

15. Appendixes

---

## 15.1 DIFFERENT GENERATIONS OF BIOFUELS

### 15.1.1 *First-generation biofuels*

The productions of 1st generation biofuels could rapidly be fostered as technologies ensue from the food industry. Pure plant oils or even used cooking oils, also called yellow grease, can thus be directly used as fuel. However, complementary processes permit to upgrade the biofuels in order to optimize their mix with conventional fossil fuels without needing to adapt the motors. They are mainly derived from cereals like maize, oil seeds like sunflower, palm fruits etc. There are basically three types of main streams first-generation biofuels: oil, alcohol and gas.

- Biodiesel

In a broad sense, biodiesel refers to pure and processed plant oils or animal fats. These oils and fats contain a mixture of triglycerides, free fatty acids, phospholipids, sterols, water, odorants and other impurities. Biodiesels are nowadays produced from a large range of oilseed crops, mainly rapeseed or canola, soybean and sunflower, palm oil and *Jatropha curcas* in tropical climates. Other potential plant oil feedstock includes mustard seed, linseed, castor oil, peanut, cottonseed, coconut, micro-algae. There are as much different biodiesels as different oil compositions. Oilseed species vary considerably in their oil saturation and fatty acid content, characteristics that significantly affect the properties of the biodiesel produced. The boiling and melting points of the fatty acids, methyl esters, and glycerides increase with the number of carbon atoms in the carbon chain, but decrease with increasing numbers of double bonds (Ma and Hanna, 1999). Saturated fatty acids are more compactable, which enhances the oil energy density. However, if they contain many saturated fatty acids, oils and fats are solid at room temperature and cannot be directly used as fuel in a diesel engine except in warm climates. The disadvantages of vegetable oils compared to petroleum diesel fuel are their higher viscosity, lower volatility and the reactivity of unsaturated hydrocarbon chains (Lang, 2001). Because of subsequent problems such as carbon deposits in the engine, engine durability and lubricating oil contamination, they must be chemically transformed to be compatible and used on a long term with existing engines (Ma and Hanna, 1999). The most widespread biodiesels are methyl esters produced from plant oils combined with methanol through transesterification. The two other routes, micro emulsion and pyrolysis are not worth it, pyrolysis notably is expensive for modest throughputs and processing removes any environmental benefits of using a biofuel (Ma and Hanna, 1999). Transesterification is an alkali-catalyzed reaction that requires 107.5 kg of methanol per ton of vegetable oil and results in the production of 1004.5 kg of methylester and 103 kg of glycerol (Graboski and McCormick, 1998). In this three-step reaction, triglycerides are converted to diglycerides, then monoglycerides and finally reduced to fatty acid esters, enhancing the viscosity of the final biodiesel. The viscosity of vegetable oils and that of their final esters are of the order of 10-20 times and twice that of diesel fuel respectively (Lang,



2001). Pre-step and catalysis make it possible to deal with the impurities such as free fatty acids and water to improve the reaction kinetics (Ma and Hanna, 1999). Methanol is preferred over ethanol because of its physical and chemical properties as well as comparative low cost (Lang, 2001; Ma and Hanna, 1999), although it introduces a part of fossil fuel in the biodiesel. For different esters from the same vegetable oil, methyl esters also appeared to be the most volatile ones (Lang, 2001). Biodiesel used as an additive to diesel fuel can improve its lubricity. This property is becoming increasingly valuable as recent legislation has mandated further regulation on the sulphur content of diesel fuels; these cleaner diesel fuels exhibiting reduced lubricity as compared to their high sulphur predecessors (Goodrum and Geller, 2005; Radich, 2004).

- Bioethanol

Ethanol, on the contrary to biodiesel, is a single-compound biofuel whose final composition does not vary with the type of feedstock. Feedstock is sugar and starch crops, which are basically equally processed through pre-treatment, fermentation by yeasts and other microbes, and distillation. Main sugar crops are sugar cane and sugar beet. Sweet sorghum could also become an interesting ethanol feedstock as a multi-use crop, whose seeds are edible and stalk contains sugar.

Main starch crops used nowadays are maize and wheat, also potatoes, cassava and sorghum grain to a lower extent. Sugar crops typically yield more ethanol per hectare with an overall better energy balance than starch crops. There are several types of fuels containing ethanol at different proportions. They are designated by the letter E followed by the percentage of ethanol in the mixture. Such as E85 is 85% ethanol and 15% gasoline and E100 is meant to be pure ethanol. Bio-butanol (butanol) is achieved by the bacteria called *Clostridium acetobutylicum* which possesses enzymatic pathways enabling it to convert the sugars in butanol (through acetobutylic fermentation). Considered as an additive to gasoline (which can be eg E85), bio-butanol is less corrosive and has a higher energy value than ethanol. It is therefore preferred to have bio-butanol in place of bioethanol. Note also that the bioethanol production units can be adapted to produce bio-butanol.

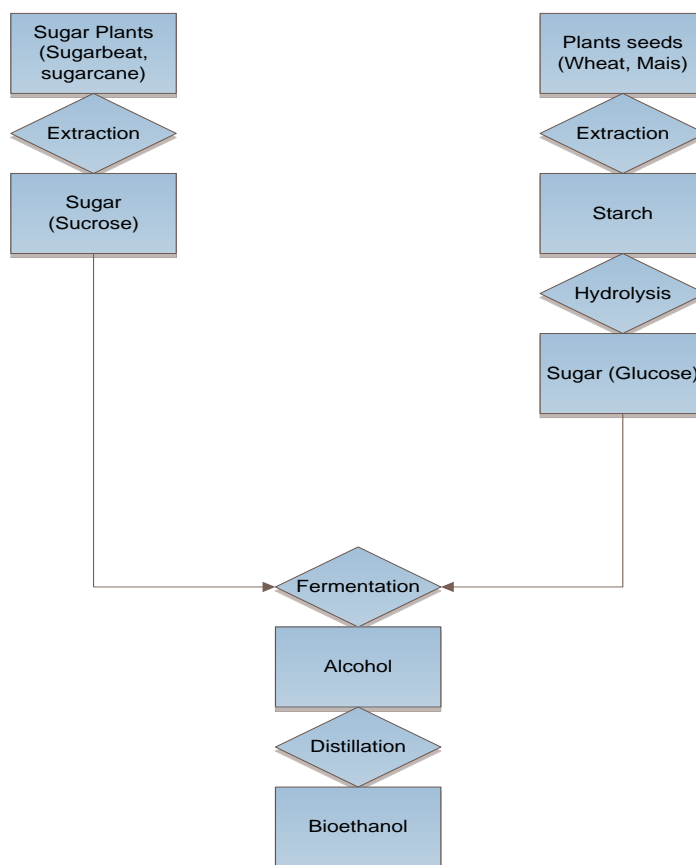

Figure 66 Production of first generation bioethanol

- Biogas

Biogas is produced through methanisation, i.e. the anaerobic digestion by bacteria of biodegradable matter such as municipal solid or agricultural waste, liquid slurry, solid manure, or maize silage for instance. The more dry matter and fatty acids the substrate contents, the greater the biogas yield is (Moras, 2007). Apart from about 55 to 70% of methane, the actual fuel, biogas also contains substantial amounts of CO<sub>2</sub>, 30 to 45%, small quantities of hydrogen sulphide and other trace gases such as ammonia. The separation of these components of biogas via a gas scrubber is an expensive prerequisite in order to use the biogas as fuel or to mix it with natural gas.

Biogas is less considered as transportation biofuel, because its target vehicle fleet remains marginal due to notably the onboard gas storage constraints. Primarily interest of biogas remains its local development as fuel for heat and power plants in rural area. About 25 million households worldwide currently receive energy for lighting and cooking from biogas produced in household-scale digesters, including 20 million in China, 3.9 million in India and 150 thousand in Nepal (Martinot and Sawin, 2009). Hence, the two prevalent types of digesters are the Chinese “fixed dome” and the Indian “floating cover” that only differ by the gas collection method (Bessou et al., 2011). Biogas production in specifically designed digesters is the most

widespread technology, although capturing methane from municipal waste landfill sites has been lately considerably developed.

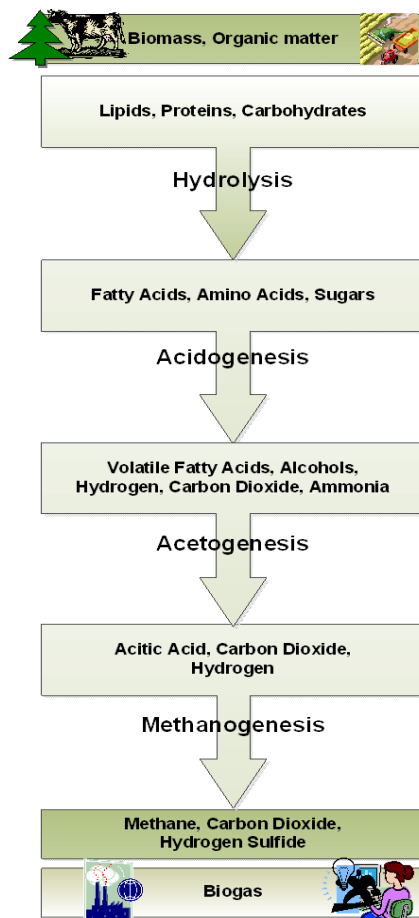

Figure 67 Anaerobic Digestion/Methanisation process in detail

In the US, waste management including the recovering of methane produced by landfills has made possible to reduce these methane emissions by 50% over the years and has become one of the largest holders of greenhouse gas emission credits (Themelis and Ulloa, 2007). Although the reaction takes several days to degrade finally just about 10 to 15% of the initial material, biogas permits to take advantage of cheap feedstock and diminish greenhouse gas emissions. Moreover, the solid residue of the process can be dried and used as fertilizer, which has a high nutrient content and whose pathogenic germs have been killed during the digestion process notably due to temperatures of 35°C to more than 50°C (Bessou et al., 2011). Biogas, as transportation fuel, could receive more attention in the coming decades especially for the use in city fleets and trucks as it has been the case in Sweden and Switzerland for a long time.

- A replacement for fossil fuel

The first generation biofuels cannot replace the fossil fuels currently in use even with increase rate of production because its energy efficiency is too low. The table below shows an estimated version of production of biofuel to replace fossil fuel.

To produce 50 million tonnes of oil equivalent (50 Mtoe), which roughly corresponds to our consumption should be mobilized 3 to 4 times the current agricultural land. Obviously this is not possible, and even meet 10% of the current consumption of transport with biofuels requires the mobilization of 30 to 40% of current agricultural land. It is still possible to affect this source of energy to specific areas: for example, the agricultural consumption which is around 4 Mtoe.

Table 23 Current evaluation of first generation biofuel replacing fossil fuel (Source: (ADEME, 2013))

Sector	Source	Gross Energy production in tons per Ha	Required energy for fertilizers, plant production and distillation (Toe/Ha)	Net energy produced per Ha (Toe)	Minimum Surface used for 50 MToe production (Km <sup>2</sup> )	French Land uses (%)
Oil	Colza	1.37	0.5	0.87	574000	1.04
Oil	Sunflower	1.06	0.29	0.77	648000	1.18
Ethanol	Sugarbeat	3.98	3.22	0.76	660000	1.20
Ethanol	Wheat	1.76	1.72	0.004	14800000	27.00

### 15.1.2 2nd generation biofuels

Second-generation biofuels are produced through biochemical (hydrolysis and fermentation) and thermochemical (pyrolysis or gasification) treatments. The biochemical or “wet process” is very similar to the 1st generation ethanol except for the feedstock, which is not specific. Indeed 2nd generation biofuels are all produced from lignocellulose, i.e. all kinds of vegetal biomass as lignocellulose forms the basic structure of vegetal cell walls. Cell walls make up a substantial portion of the dried biomass: about 60-80% and 30-60% in the stems of woody and herbaceous plants, respectively, and about 15-30% in their leaves (Möller et al., 2007).

#### ➤ Biochemical procedure

Lignocellulose consists in intricate assemblages of cellulose, hemicellulose and lignin, whose proportions and molecular organization vary depending on the type of biomass. A typical range is 40 to 55% cellulose, 20 to 40% hemicellulose, and 10 to 25% lignin (Hunt, 2006). The other minor components of cell walls are proteoglycans and pectins that glue together all the lignocellulosic compounds. The conformation of glucose residues in the crystalline cellulose core of cell-wall microfibrils forces the hydroxyl groups into radial orientation and the aliphatic hydrogen atoms into axial positions. It leads to the creation of strong inter chain hydrogen bonds between adjacent chains in a cellulose sheet, which make cellulose resistant to enzymatic hydrolysis, and weaker hydrophobic interactions between cellulose sheets that contribute to the formation of a water layer near the hydrated cellulose surface protecting cellulose from acid hydrolysis. Furthermore, the microfibrils are embedded in the matrix of hemicelluloses and lignin, this last one also contributing to make cells walls hydrophobic and more resistant against enzymatic attack (Möller et al., 2007). Other molecules such as for instance, waxes or inhibitors to fermentation that naturally exist in the cell walls or are generated during conversion processes, also contribute to biomass recalcitrance (Himmel et al.,

2007). This recalcitrance is the primary barrier to produce ethanol from lignocellulosic feedstock, commonly referred to as cellulosic ethanol. Indeed expensive pre-treatments are necessary to breakdown this resistance and reaching a cost-effective cell wall saccharification, i.e. the degradation of cell walls into mono saccharides, is the key that could really permit cellulosic ethanol to enter the market.

Pre-treatments include physical methods such as milling and grinding, high-pressure steaming and steam explosion, and biological (lignin- or/and cellulose-degrading organisms) or chemical methods (alkali or acid treatments, solvents) to solubilize parts of the hemicelluloses and the lignin. Mono saccharides from cellulose (glucoses) and hemicelluloses (pentose sugars) are then released through acid- or enzyme-catalyzed hydrolysis, and finally fermented.

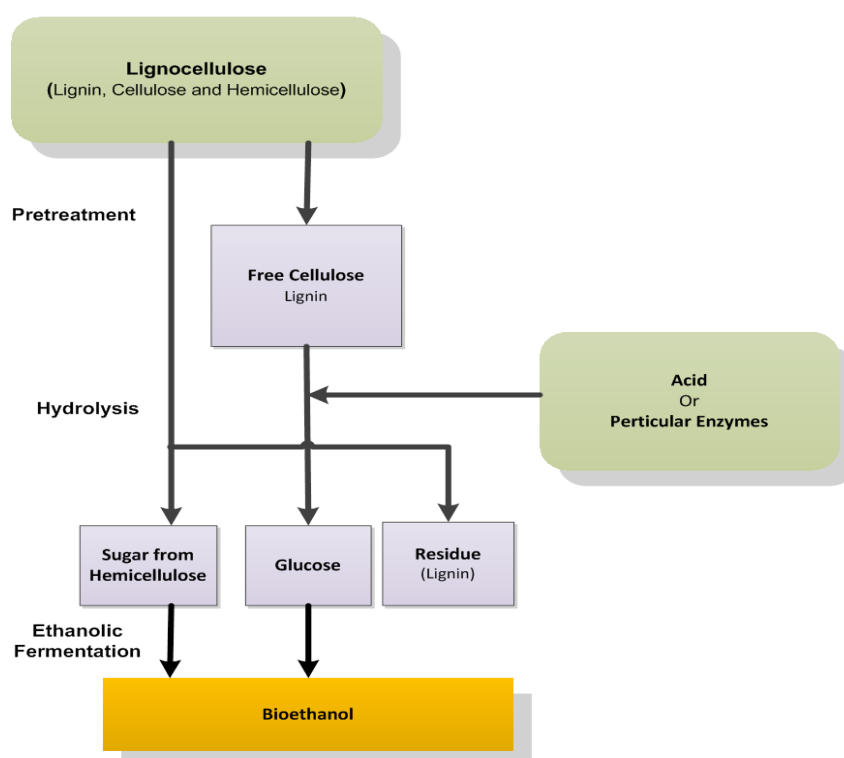

Figure 68 Production of bioethanol through biochemical method

Concentrated or dilute acids hydrolysis methods are more mature but very energy intensive and present the disadvantage to potentially also degrade the mono saccharides. Enzymatic degradation on the contrary is more specific and perceived by many experts as a key to cost-effective saccharification, but none of these methods is currently cost-effective (Möller et al., 2007). As an example, hydrolysis of pre-treated lignocellulosic biomass requires 100-fold more enzymes than hydrolysis of starch (Lichtfouse et al., 2011).

Current biomass-conversion technologies were developed empirically based on a limited understanding of the biological and chemical properties of biomass (Himmel et al., 2007).

Therefore, all research efforts also rely in parallel on fundamental researches to better understand and characterize the cell walls of a very wide range of biomass feedstock. In the US, attention is especially paid to maize stover, wood waste and switchgrass, whereas sugar cane producers are obviously more interested in converting the sugar cane bagasse. Researches worldwide include breeding programmes to develop new varieties with interesting phenotypes in terms of growth and resistances, or regarding specific biorefinery-related assets, i.e. regarding the cell wall composition. Researches also include genetic engineering.

➤ Thermochemical method

Whereas lignin cannot easily be converted through biochemical processes, it can be burnt. Therefore, thermochemical processes are especially more effective in the case of plants with a high content of lignin, up to 30-35% of the biomass in some plants (Fulton et al., 2004; Möller, 2006). Main criteria for biochemical conversion of lignocellulosic feedstock are the quantity of sugars and the structure of the lignocellulose; in the case of thermochemical conversion, main criteria are rather the biomass' bulk density, moisture and ash contents, and the calorific value (Möller et al., 2007). In a rough overview, agricultural residues and grasses with intrinsic higher sugar content and lower lignin content are generally more suitable for enzymatic conversion, whereas dense woody biomass with higher amounts of lignin and lower amounts of ash are comparatively more oriented toward thermochemical conversion. Ash can indeed lead to the slagging or fouling of heat-transfer surfaces during gasification. However, improvement of current technologies shall notably permit to reach efficient conversion ratios for a mix of the cheapest and most available feedstock within the supply area of an implemented technology (Hunt, 2006).

The thermochemical pathway is referred to as Biomass to Liquid (BtL) as an analogy with the conventional fossil Gas to Liquid pathway (GtL). Nowadays, 8% of the worldwide produced syngas is converted into transportation fuels through GtL processes; the overall production of syngas corresponding to almost 2% of the total worldwide primary energy consumption. Thereby, thermochemical technologies are well developed but have to be adapted to biomass feedstock in qualitative terms as well as in terms of plants' scale, considering that biomass availability might appear to be a limiting factor (Van der Drift and Boerrigter, 2006). The core process is gasification that involves using heat to break down the feedstock molecules and produce a synthetic gas or syngas, also called "bio-syngas" when biomass is the feedstock and whose compound-mix of hydrogen, carbon monoxide and dioxide water vapour, methane and nitrogen vary depending on the process (Fulton et al., 2004). Hydrothermal upgrading (HTU) is another process that makes it possible to transform biomass into a "biocrude" liquid by dissolving the cellulosic materials in water under high pressure but relatively low temperature. Bio-oils produced via pyrolysis or HTU can be subsequently upgraded to diverse hydrocarbon liquids and fuels (Fulton et al., 2004).

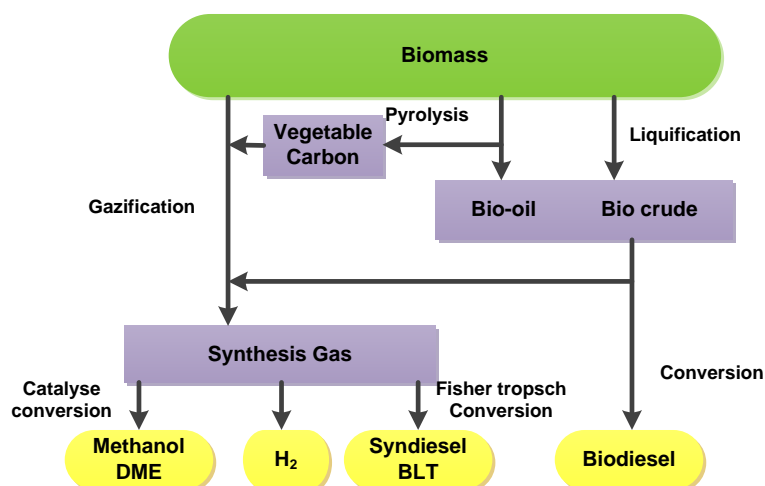

Figure 69 Production of Biodiesel through thermochemical process

➤ 2<sup>nd</sup> Generation biofuel as alternative for fossil fuel

Production wise second-generation biofuels have more potential than that of first-generation biofuels because they are produced along with other plants and can solve the problem of depletion of fossil fuels. Thus, the ADEME (Agence de l'Environnement et de la Maîtrise de l'Energie) estimated that France has the capacity of producing 25 Mtoe of second-generation biofuels, which corresponds to half of the current consumption of oil (Bessou et al., 2009). However, the fuel of the future is far too expensive and production techniques are not yet mature enough to consider a production on an industrial scale. Indeed thermochemical method is too energy intensive and the biochemical pathway, still needs much more development and advancements in the application of more efficient enzymes.

### 15.1.3 3rd Generation biofuels

Design for the third generation fuels (algae biofuel), means that fuels produced from microalgae culture. Microorganisms can be free from the constraints of soil and does not mobilize arable land, which then remain available for conventional crops. Two main methods are used for the production of microalgae: ponds/large basin and bio photo reactors.

The frontier between 2nd and 3rd generation biofuels is conceptual and is not due to differences in biomass feedstock or radically new conversion processes. Still further technological breakthroughs is needed to permit the economic viability of complete integrated bio refinery complexes, as well as technological revolutions in the transportation sector to introduce hydrogen as competitive fuel for automotive. Hydrogen (H<sub>2</sub>) is a fuel, whose combustion produces only water. Although water vapor is the most important greenhouse gas, its equilibrium in the atmosphere seems to be ensured by the natural water cycle.



*Figure 70 Raceway type culturing of micro algae for biofuel production  
(source: www.geni.org)*

Hydrogen has been used by the aerospace industry since the 1960s and is nowadays especially used in the petrochemical industry to make ammonia fertilizers, to upgrade lower quality fractions in the refining of fossil fuels, to produce also glass, lubricants, refined metals and processed foods (Zeman, 2007). According to Shell, the world market for distributed and centralized hydrogen is estimated at approximately 45 million tons per year. However, hydrogen is not to be found in nature under this diatom form and must be produced from hydro carbonates or water requiring considerable energy inputs.

Considering the risks and following costs implied in the development of new biofuel chains, industries' investments are significantly subordinated to the commercial perspectives that global policies underpin. These policies tend to respond to global issues and inevitably affect trades, as economic incentives often appear as efficient levers to reach targets.



## 15.2 IMPACT ASSESSMENT WITH CML 2 BASELINE

Figure 71 Impact assessment through Excel with CML 2 Baseline

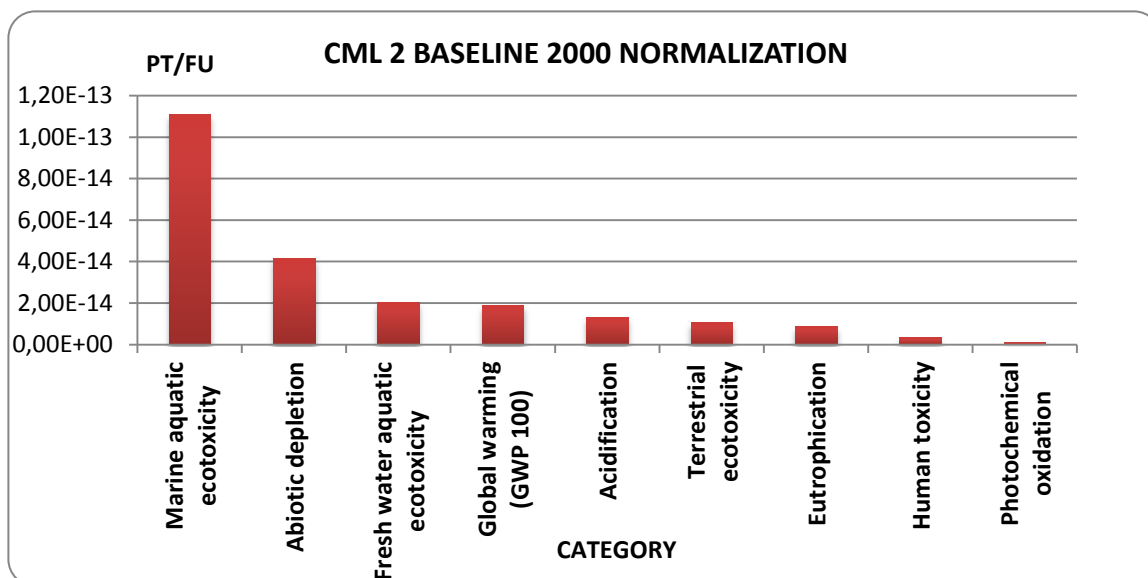
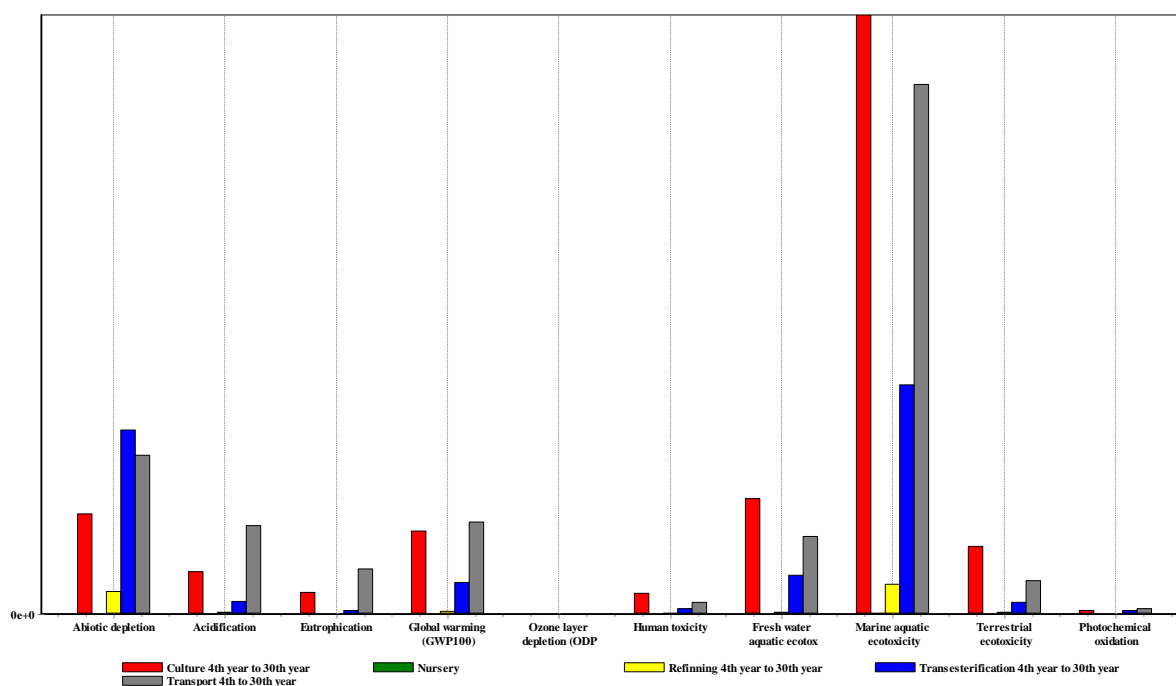

Figure 72 Impact assessment through SimaPro with CML 2 Baseline



## 15.3 DETAILS STUDY OF TRANSESTERIFICATION PROCESS

### 15.3.1 *Jatropha* Transesterification

Chitra et al., (2005) optimize transesterification of *Jatropha* oil using a NaOH alkaline catalyst. Under the optimum reaction conditions Table 24, the conversion of *Jatropha* oil to methyl esters was 98% in 90 min. It is noteworthy that the free fatty acids (FFA) content in

crude *Jatropha* oil was reduced to 0.25% from 3.1% using NaOH. It is undeniable that NaOH will induce soap formation but at the same time NaOH will also neutralize free fatty acids to an acceptable level to meet biodiesel specifications. Nevertheless, an extra step is needed to remove the sodium soap after the reaction. The catalyst amount, molar ratio of methanol and reaction time were not only investigated but also optimized using completely randomized design (CRD). Large scale production of biodiesel from 25 kg of *Jatropha* oil has resulted in 24 kg of biodiesel (96% of yield), which is only reduced by 2% as compared to lab scale (Chitra et al., 2005). The properties of biodiesel produced from *jatropha* oil also fall within the limits of Bureau of Indians Standards (BIS) specification.

A similar alkaline catalyst was also used by Om Tapanes et al., (2008), but the catalyst was mixed with the methanol or ethanol before mixing it together with *Jatropha* oil. Sodium methoxide/ethoxide was formed when NaOH was mixed with methanol/ethanol and its act as a homogeneous catalyst. Om Tapanes et al., (2008) is slightly lower as compared to that of Chitra et al., (2005), the reaction time is three times faster Table 24. They also investigated the effect of alcohol on transesterification of *Jatropha* oil. In methanol, the biodiesel yield was 96% in 30 min but when ethanol was employed biodiesel yield dropped to 93% under the same reaction conditions. The reaction rate with ethanol is slightly slower than that of methanol, as from the kinetic rate constant of methanol is higher than of ethanol. It is more difficult to break down molecule of ethanol to form ethoxide anion as compared to breaking down methanol to methoxide anion (Om Tapanes et al., 2008). In contrast, Asakuma et al., (2009) had pointed out that transesterification process occurs via transition state, when the alkoxy group attacks the carbon of the carboxyl group, an intermediate polygonal ring is formed. They predicted that lower activation energy is acquired when a longer chain alcohol formed a larger polygonal ring (Asakuma et al., 2009). This would mean that longer chain alcohols, such as ethanol and n-butanol are more suitable to be used to produce alkyl ester biodiesel.

Transesterification of a mixture comprised of *Jatropha* oil (5.5% FFA) and waste cooking oil (0.45% FFA) using potassium hydroxide (KOH) was studied by Berchmans et al., (2013). The level of FFA in the mixture was adjusted to about 1% prior transesterification to avoid soap formation. The highest conversion of 97% was achieved in 2 h using methanol to oil ratio of 6:1, a stirring speed of 900 rpm, 1% w/w of KOH to oil and the reaction temperature at 50 °C.

Alkaline-catalyzed transesterification for biodiesel production is the common method to produce biodiesel from *Jatropha* oil today. This method will generate high quality biodiesel from *Jatropha* oil in a short period of time. However the disadvantages (such as generating large amount of wastewater from alkaline catalyst, high cost of refining *Jatropha* oil as raw material and additional purification step is necessary to remove the alkaline catalyst) have motivated many researchers to find a better alternative method to produce biodiesel.

Recently, Vyas et al., (2009) have supported potassium nitrate ( $\text{KNO}_3$ ) on alumina ( $\text{Al}_2\text{O}_3$ ) as solid base catalyst for transesterification of Jatropha oil. A high amount of FFA acid content in Jatropha oil, which contain up to 5.3% FFA was used. The conversion of Jatropha oil to biodiesel up to 87% in 6 h was obtained by using  $\text{KNO}_3/\text{Al}_2\text{O}_3$ . After the first reaction, the catalyst was calculated again at 500 °C for 4 h prior to reuse. However, the activity decreased by 9% as compared to the first reaction and it continued decreasing to 72% on the third reaction. Thus, this catalyst only can be reused for three times due to poor reusability.

ZHU et al., (2006) have studied the use of super solid base of calcium oxide (CaO) as heterogeneous catalyst for biodiesel production from Jatropha oil. CaO was chosen because it was believed to exhibit strong basicity and the presence of more active sites that would able to improve the transesterification reaction of Jatropha oil. The commercial CaO was immersed in ammonium carbonate solution to increase the base strength and calculated at 900 °C for 1.5 h. The FFA's acid content of Jatropha oil used was less than 0.5%, which suggested that concentration of FFA was very low. The highest conversion of Jatropha oil to biodiesel was 93% in 2.5 h. When the reaction was extended for more than 3 h, formation of white gel in the product was observed. This will increase the viscosity of biodiesel, which decrease in the fuel's ability to flow and further induces incomplete burning of the fuel with ignition delay. The catalyst could be reused at least three times without significant loss of catalytic activity. Nevertheless, (Granados et al., 2007) have pointed out that the dissolution of CaO does occur even if the catalyst can be reused for several times without significant deactivation. They observed that the catalytic activity of CaO is not only contributed by the heterogeneous active sites but also the homogeneous active species due to the dissolution of CaO in methanol.

Homogeneous alkaline catalyst such as NaOH and KOH have been proven to be a very good alkaline catalyst for the transesterification of Jatropha oil if the FFA content is lower than 1%. The final yield product seems to be dependent on the FFA content of Jatropha oil. Among those alkaline catalysts, homogeneous NaOH seemed to be the best alkaline catalyst with the highest conversion of 98% in the shortest reaction time Table 24. However, due to the high level of purity and low (FFA) content of Jatropha oil, which require extra refining processes are expensive. Moreover, the separation process and alkaline wastewater treatment would increase the cost of biodiesel. Although the application of heterogeneous alkaline catalyst would eliminate those post-reaction purification steps, it did not result in a high conversion as compared to homogeneous alkaline catalyst. Reusability of heterogeneous alkaline catalysts is proven to be a challenging task. Although studies have proven that the heterogeneous catalysts possesses a high catalytic activity and could be reused for at least three times, further study on the reusability is necessary.

Table 24 Studies related to Alkaline catalyzed Transesterification of *Jatropha*

Authors	Alkaline Catalyst	Time (Min)	Reaction Temp C°	Molar ratio	Catalyst amount	Conversion %
Tang et al., (2007)	Homogeneous NaOH	28	250	24:1	0.8%	90.5
Om Tapanes et al., (2008)	Homogeneous NaOH	30	45	9:1	0.8%	96
Chitra et al., (2005)	Homogeneous NaOH	90	60	6:1	1.0%	98
Berchmans et al., (2013)	Homogeneous KOH	120	50	6:1	1.0%	97
ZHU et al., (2006)	Heterogeneous CaO	150	70	9:1	1.5%	93
Vyas et al., (2009)	Heterogeneous KNO <sub>3</sub> /Al <sub>2</sub> O <sub>3</sub>	360	70	12:1	6%	87

### 15.3.2 Transesterification Description

Vegetable oils and products synthesized from natural raw materials are having a strong come back in the recent decades. One of the major reasons for the increased utilization of fatty chemicals for industrial use has been the ability to tailor the products for specific needs. End uses of upgrade products or derivative compounds are extremely numerous but usually highly specialized. Major areas of applications are food industry, pharmaceuticals, textile, synthetic lubricants and the last but not least into the automotive fuel sector. This application is the subject of our report.

Indeed, liquid biofuel for transport in recent years have benefited from significant political support due to their potential role in curbing climate change and reducing our dependence on fossil fuels. However, the growth of energy crops has raised concerns due to their high consumption of conventional fuel, fertilizers and pesticides, their impacts on ecosystems and their competition for arable land with food crops. That is why, *Jatropha curcas*, a perennial, inedible crop well adapted to semiarid regions, has received much interest as a new alternative for biofuel production. Indeed, *Jatropha curcas* permits to minimize adverse effects on the environment and food supply. Some studies were done using life cycle assessment to quantify the benefits in term of greenhouse gas emissions and fossil energy use, compared with fossil diesel fuel and other biofuels. In summary, biodiesel from *Jatropha curcas* has a much higher performance than current biofuels, relative to oil-derived diesel fuels. According to one study, *J. curcas* biodiesel allows a 7% saving in greenhouse gas emissions compared with conventional diesel fuels, and its energy yield i.e. the ratio of biodiesel energy output to fossil energy input- is 4.7. Thus, *J. curcas* production is eco-compatible for the impacts under consideration and fits into the context of sustainable development.

In this study the CAPE, computer aided process engineering method, is a good solution. This method permits to simulate the whole process, a part or a unit operation. CAPE can help to create or modify a simulation, so in our study, CAPE permits to model and simulate the transesterification, part of our development process of the biodiesel production.

### 15.3.3 Overview of complete process

In order to have a better understanding of the reaction of transesterification, it is necessary to be aware of its role in the complete process which permits to turn oils or fats to biodiesel. The following scheme summarizes the process, distinguishing the reagents in blue from the elementary operations in black. When the oil contains more than 2.5% of free fatty acids, a pretreatment, such as a membrane filtration, is used in order to remove the contaminants of the oil. The obtained oil is then mixed with the alcohol and the catalyst in order to form biodiesel: it is the step of the transesterification. Then it is necessary to separate the esters from the side products also formed during the reaction by decantation and sometimes with the use of a centrifuge. To finish, the crude biodiesel thus obtained is purified by a step of neutralization, a passing through an alcohol stripper and a washing step in order to obtain the final purified biodiesel.

Some studies were made using the LCA method in order to determine the environmental impact of the production of biodiesel, explained in the previous flow sheet. These impacts were calculated for each elementary process, from the harvest of the plant extraction to the commercial distribution. In the following process tree, the inputs and outputs are detailed for each elementary process. *Jatropha* seedlings are assumed to be grown in through nurseries.

Then the seeds are coated and soaked in fungicide before sowing, and may be sprayed with insecticides in case of attack during the nursery period. The harvesting takes place. Then, before the transesterification there are a lot of transportation and treatments such as the transportation of raw material, the cold pressing, the CVO transportation, the refining. In the end, the reaction of transesterification can be made. Even after, the biodiesel production, the life cycle inventory of biodiesel is not finished; there are two more steps which are the transport of the biodiesel and then the combustion of this one. The following study only be focused on the key step of the production of biodiesel: the reaction of transesterification.

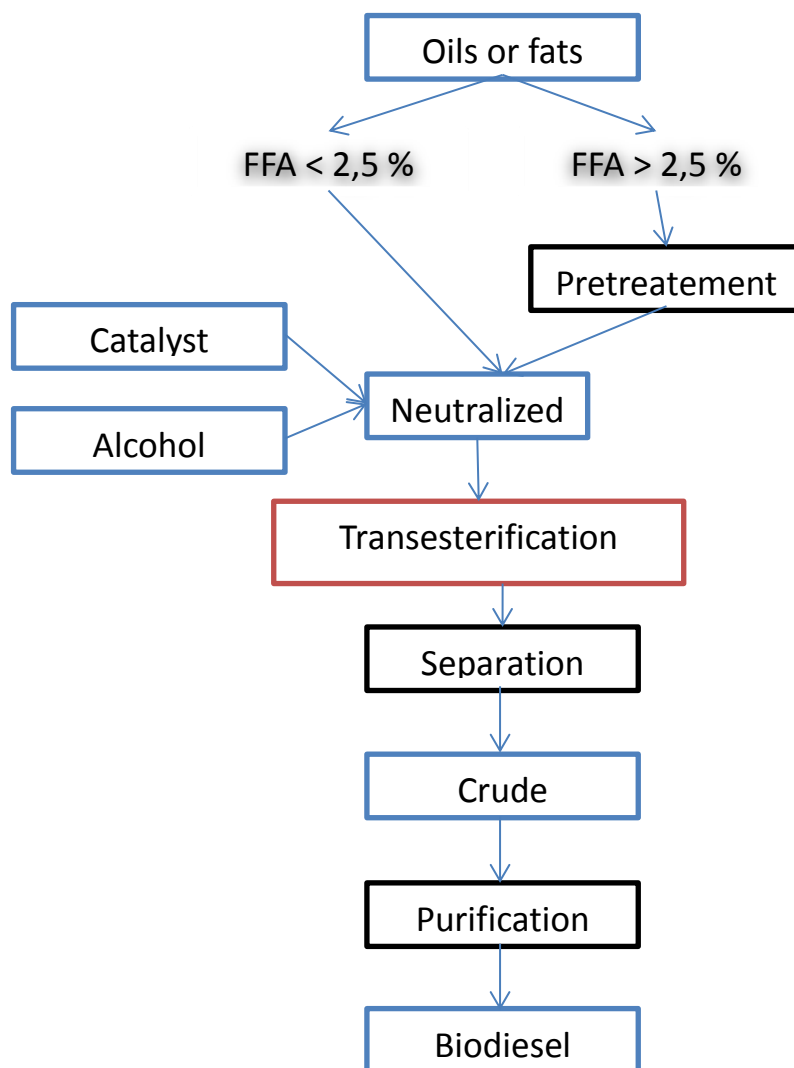

Figure 73 Process flow chart of biodiesel production

#### 15.3.4 The reaction of Transesterification

Transesterification is the key reaction in the process of production of biofuel by *Jatropha*. That is why a reminder of the different types of reactions of transesterification is made, and then the application and the kinetics of the reaction in the process is developed. In organic chemistry, the esters are chemical compounds obtained by reaction of oxoacid and a hydroxyl compound such as alcohol, phenol. In the esterification reaction, at least one hydroxyl group is replaced by an alkoxy group: esters are formed by condensing an acid with an alcohol.

Transesterification is one of the numerous reactions bringing into play an ester. Three paths are known in the implementation of the transesterification reaction: ester-alcohol exchange, ester-acid exchange and ester-ester reaction.

### 15.3.4.1 An ester alcohol exchange (alcoholysis)

Often catalyzed by an acid or a base, this reaction consists in exchanging the organic group R'' of an ester with the organic group R' of an alcohol. Like the others transesterification reactions, the alcoholysis is a reversible reaction.

Equation 6 Alcoholysis

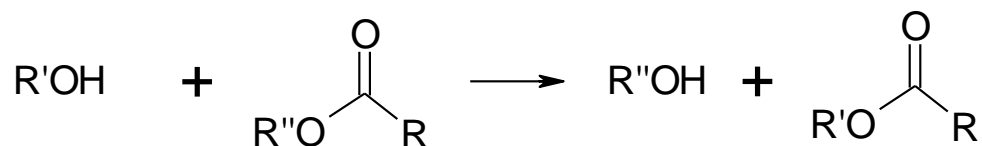

Many examples illustrate the ester-alcohol exchange reaction pathway: reacting ethylene glycol with dimethyl terephthalate leads to polyethylene terephthalate (PET), the depolymerization of PET thanks to methanol (methanolysis), the synthesis of polyvinyl alcohol (PVOH, PVA or PVAI) by the action of methanol on polyvinyl acetate (alcoholysis), the production of methyl esters (or ethyl esters) via the methanolysis (or ethanolysis) of triglycerides.

### 15.3.4.2 The ester acid exchange (acidolysis)

The acidolysis corresponds to the hydrolysis of the alkoxy group thanks to the action of the acid. Here is the general reaction of the ester-acid transesterification:

Equation 7 Acidolysis of an ester

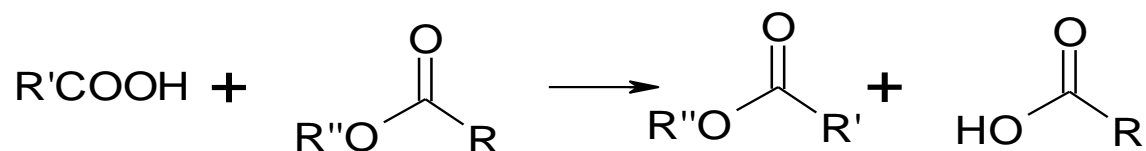

### 15.3.4.3 The ester-ester exchange

Finally, here is the general reaction of the ester-ester transesterification in which the two initial alkoxy groups are exchanged.

Equation 8 Ester-ester exchange

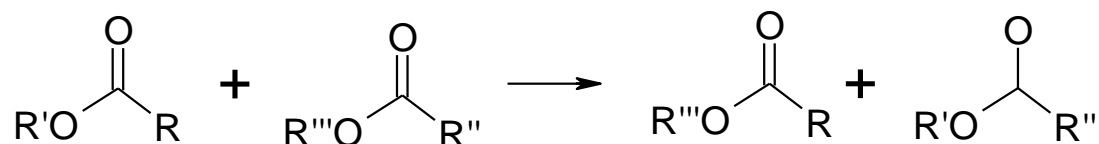

One should note that intramolecular transesterification is also possible. In this study, for the production of biodiesel by Jatropha oil, we consider the ester alcohol exchange.

### 15.3.5 Transesterification in biodiesel production

#### 15.3.5.1 Main reaction

Among these three reaction pathways, the ester-alcohol path is the most common one. The production of biofuels, which is the topic of our investigation, brings into play this reaction. In this case, triglycerides are transesterified by methanol to give fatty acid esters, the latter exhibiting a much lower viscosity and density. Many alcohols such as ethanol, propanol, butanol and amyl alcohol are also used to produce the biofuel. However, methanol and ethanol are the most commonly used. Between these two alcohols, the use of methanol is preferred because of its lower cost and of his properties. Actually, it permits an easy dissolution of the alkali catalyst and fastens the reaction with the triglyceride.

The methyl ester is obtained by the following reaction:

Equation 9 Biodiesel production

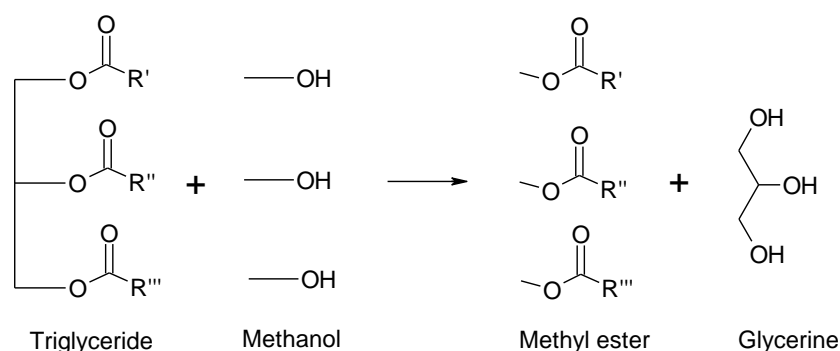

In this equation, R, R' and R'' are long chain hydrocarbons that can be chains from palmitic, stearic, oleic, linoleic or linoleic oil.

This reaction takes place in three steps: the triglyceride is first reduced to a diglyceride giving a first fatty acid ester. Then the diglyceride is converted to a monoglyceride liberating an additional fatty acid ester and finally, the monoglyceride is converted to glycerine liberating the third fatty acid ester. So, we need 1 mol of triglyceride for 3 mol of methanol, and after reaction we obtain 1 mol of glycerin for 3 mol of methyl ester.

It is important to explain that glycerin is another name for the glycerol or the propane-1,2,3-triol. Biodiesel production by transesterification reactions needs a catalyst. This catalyst can either be an alkali (typically KOH, NaOH) compound, an acid (H<sub>2</sub>SO<sub>4</sub>) or an enzyme. Yet, Wang et al. have highlighted in 2007 that the first two types of catalysis require a shorter reaction time and a lower cost compared to the enzymatic catalysis. Nowadays, most of the produced biodiesels are base (alkali) catalyzed mainly because it involves milder operating temperature and has a higher conversion rate (up to three orders of magnitude greater than acid-catalyzed reaction). Moreover, according to some life cycle assessment, it is proved that the process using sodium hydroxide has greater environmental impacts on human health and the



ecosystem, however resource depletion is lower (Kaewcharoensombat et al., 2011). These two catalysts can be either homogeneous or heterogeneous.

It can be precised that the enzyme catalysts are becoming more and more attractive because of their capacity to avoid the formation of soap and of their easier process of purification. The different steps of the alkali-catalyzed transesterification and the mechanisms that come into play are going to be presented here.

Below is the mechanism of each step:

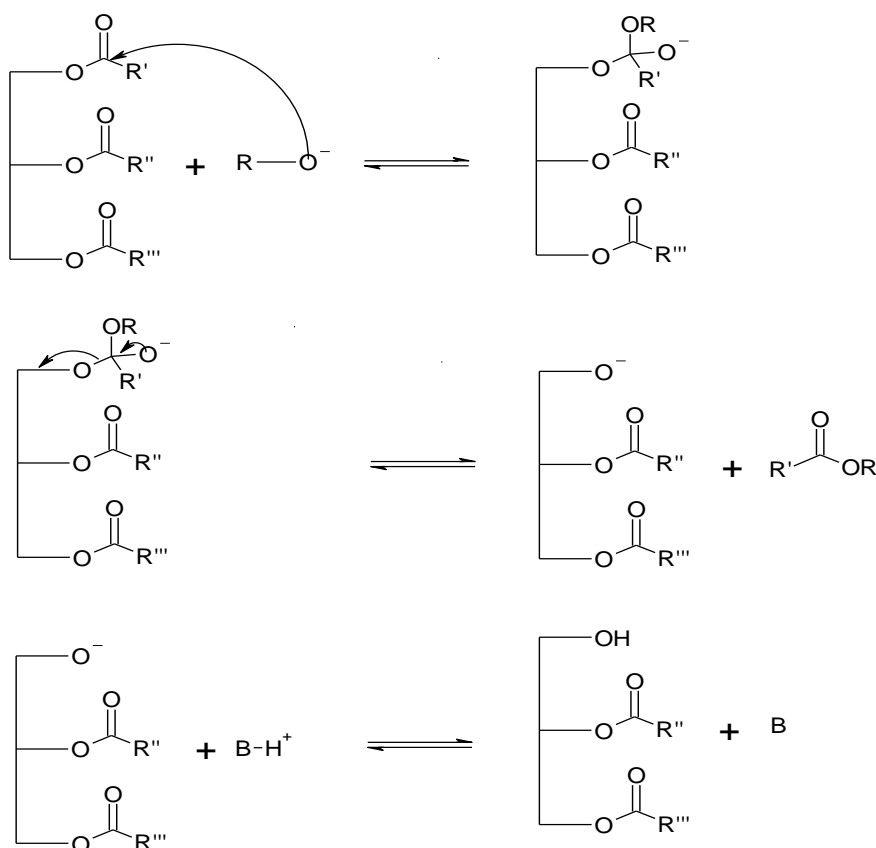
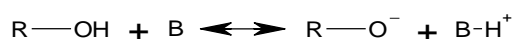

Figure 74 The four-step base catalyzed transesterification of triacylglycerol

Indeed, during the first step, the alkoxide anion attacks the carbonyl group of the glyceride in a nucleophilic addition. Then, the intermediate thus formed eliminates a molecule of an alkyl ester to form a glyceride anion. To finish, the catalyst is regenerated which permits to repeat twice the cycle in order to obtain the glycerin and the liberation of three alkyl ester. Actually, each cycle lead to the transformation of an ester function into an alcohol one.

#### 15.3.5.2 Side reaction

Finally, some side reactions have to be considered in biofuel production.

- Saponification reaction of the catalyst

The first side reaction is the saponification reaction of the catalyst, sodium hydroxide or potassium hydroxide with the free fatty acids (FFA). It leads to the formation of water and soap as it can be seen in the following figure.

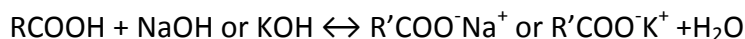

On one hand, the saponification avoids the separation of the two final products, the glycerol and the esters and decreases the yield of biodiesel. On the other hand, following the previous scheme, more and more soap and water is produced until the catalyst is finally consumed and deactivated.

- Hydrolysis reaction of triglyceride

The formation of water in the saponification is also responsible of a delay in the transesterification reaction, through the undesirable reaction of the following hydrolysis reaction:

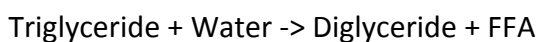

Actually, this reaction consumes a part of the triglyceride, main reactive of the transesterification.

### 15.3.5.3 *Influence of the parameters on the reaction*

In order to have a process that yields a good conversion rate, the side reactions explained in the previous part such as saponification and hydrolysis must be kept to a minimum. In fact, these reactions depend on the quality of the feedstock: excessive amount of free fatty acids (often witnessed in used cooking oils) leads to the neutralization of the reaction mixture with excess base (catalyst) resulting the two undesirable reactions.

In order to optimize the production of biodiesel, some parameters have to be taken into account. First, the Methanol/Triglyceride molar ratio has a crucial influence on the yield of the transesterification reaction. Indeed, excess alcohol with the adequate catalyst forces the reaction equilibrium toward the products of esters and glycerol. Even though stoichiometry indicates a molar ratio of 3:1, the real reaction typically requires from 6:1 to 20:1 for base catalyzed transesterification and around 50:1 for acid transesterification.

An increase in the reaction time permits to obtain a better mixing and dispersion of the alcohol into the oil, which lead to an increase of the conversion.

The increase of the reaction temperature leads to an increase in the reaction rate because of the decreasing in the viscosity of the oil. The vaporization would be avoided if the boiling point of the alcohol is not reached.

If the concentration of the catalyst is too low, the conversion of the transesterification will be really weak. The stirring of the reagents also seems to be important as it permits to increase

the contact area between the reagents and to ensure a good homogeneity. Indeed, a reasonable mixing leads to a better initiation of the reaction and in the end a better yield.

To optimize the reaction, it is necessary to work under reasonable values. Indeed, a reaction too long, a temperature too high, an excess of catalyst or a stirring too high can promote the undesirable reaction of saponification. Thus, this excess in the parameters will have an economic impact as it is necessary to separate the side product from the main one and an impact on the productivity as it will decrease the yield of the biodiesel.

In the end, the optimum values found for the reaction were the following one:

Table 25 Experimental conditions for the reaction

Temperature (°C)	50
Pressure (bar)	2.5
Time (min)	120
Conversion rate (%)	97
Methanol/oil (wt) ratio	6 : 1
Catalyst amount (% wt)	0.5

#### 15.3.5.4 Kinetics of the transesterification

After the presentation of the transesterification involved in production of biofuel and the study of the critical parameters in this reaction, we study the kinetics of this specific transesterification.

As it was explained in the previous part, the base catalyzed transesterification reaction is a four steps reaction with the following mechanism:

- Nucleophilic attack of the alkoxide anion, formed in a pre-step, on the carbonyl group of the glyceride to form a tetrahedral intermediate
- Reaction of the intermediate with methanol to regenerate the methoxide and form another tetrahedral intermediate
- Breaking of the tetrahedral intermediate to form the alkyl ester and the glyceride anion
- Regeneration of the catalyst and beginning of a new cycle

The first step can be considered as the fastest one because of the high reactivity of the alkoxide anion with glyceride. Actually, to pass from the initial complex to the first intermediate, the activation energy needed is low. The third step is not as easiest as the first one in terms of energy. Actually, in order to break the bonds of the tetrahedral intermediate, a large energy barrier has to be overcome. As it is the slowest step of the reaction, this step can be considered as the one which controls the rate of the reaction of transesterification. The final step involves a transition state with small activation energy as the regeneration happens quite quickly.

Om Tapanes et al., (2008) have also exhibited that the reaction rate of the transesterification reaction with a homogeneous base catalyst can be described as follows:

$$(-r_{TG}) = k_1[C_{TG}]^\alpha[C_{ROH}]^\beta + k_2[C_{RCOOR}]^\delta + [C_{GL}]^\gamma$$

Where:

- $(-r_{TG})$  is the triglycerides rate (mol/(volume/time))
- $\alpha$ ,  $\beta$ ,  $\delta$  and  $\gamma$  the reaction order of triglycerides, alcohol, biodiesel and glycerol respectively
- $k_1$  and  $k_2$  the specific velocity of the reaction
- $CTG$  and  $CROH$  the molar concentration of triglyceride and alcohol

Making the assumption that the terms  $\beta$ ,  $\delta$  and  $\gamma$  are zero, the previous equation can be simplified as follows:

$$(-r_{TG}) = k_1[C_{TG}]^\alpha$$

Then, the differential equation characterizing the transesterification reaction would be:

$$-dX_{TG}/dt = k_1 C_{TG0}(1-X_{TG})^\alpha$$

The reaction order has then been determined experimentally by Om Tapanes et al., (2008) for both methanol and ethanol using  $NaOCH_3$  as catalyst. Here are the obtained values:

Table 26 Effect of the kind of alcohol on the reaction rate

	Methanol	Ethanol
$\alpha$	2,403	1,266

It can be noticed that ethanol causes a lower reaction rate compared to the methanol's one. Actually, even if the activation energies involved in the reaction are quite similar for both ethanol and methanol, the methoxide anion synthesized in the pre step with methanol is more easily formed than the ethoxide anion with ethanol. This gap between the two rates was another reason for what methanol was chosen compared to ethanol.

Jain and Sharma, (2010) showed that compared to an acid catalyzed esterification, the reaction of transesterification can be done quite quickly. Actually, the reaction rate for the transesterification was rather four times bigger than the one for the esterification. The difference of speed can be explained by the considerable quantity of tetrahedral intermediate formed for the esterification, which interferes with the formation of desired product. This data gives the interest of this process compared to a classic esterification.

### 15.3.6 Process study

As explained before, the transesterification needs a complex process. For example, some separations such as the one in the final step, and the regenerations of the catalysts are needed

to obtain a glycerol with the highest purity. In a first part classic processes are presented. Then, the processes in development are detailed.

### 15.3.6.1 Current processes

The classic processes are those in which the presence of a catalyst is necessary. As said before, the catalyst can be in a heterogeneous or a homogeneous layer. Moreover, the process can be either a batch process or a continuous one. Hence, the processes used to conduct a transesterification are the following ones.

#### ➤ Homogeneous batch process

The following scheme shows the entire homogeneous batch process for the step of the transesterification.

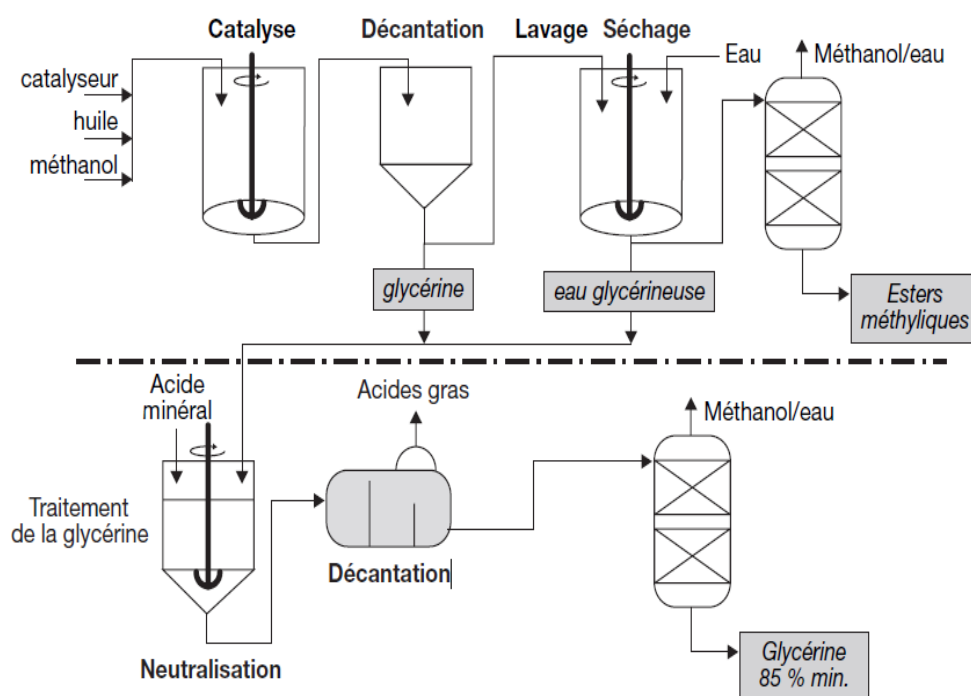

Figure 75 Homogeneous batch process Esterfip process – IFP licence (Ballerini, 2006)

Oil and methanol are introduced into a reactor equipped with a stirring system. The contents are heated to a temperature of 45 to 85 ° C under a pressure of 2.5 bar absolute maximum, before adding the catalyst solution. One hour is necessary to reach thermodynamic equilibrium. The methyl esters are separated from the glycerin in a static decanter before being introduced into a second stirred reactor to be washed with water, which eliminate residual salts and glycerin. The traces of methanol and water in the esters are removed by distillation. The basic catalyst and soaps are found mainly in fraction glycerin. This fraction and the washings are combined and then neutralized with hydrochloric acid. And then, the glycerin is separated from the mixture methanol/water.

In function of technology and catalyst, the mass yields in methyl esters from the oil vary from 98.5 to 99.4%. Losses correspond to saponification reaction.

➤ Homogenous continuous process

In a presence of a homogeneous catalyst, a continuous process can be detailed.

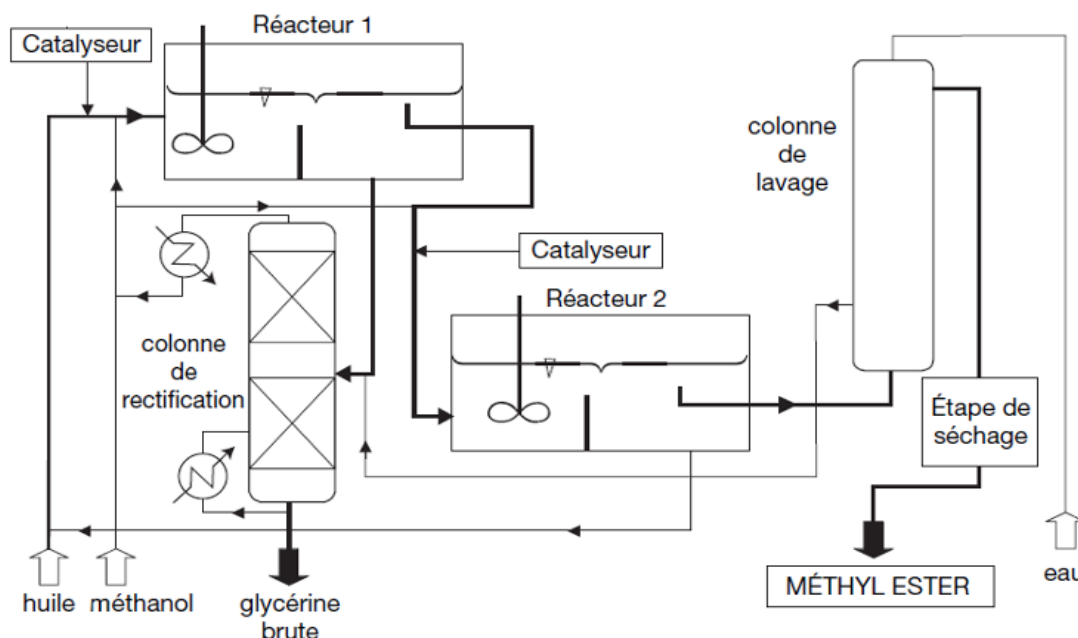

Figure 76 Schematic design of a continuous process of EMHV (Process proposed by the Lurgi company) (Ballerini, 2006)

The main advantages are the reduction in equipment size, so in investment and the decrease in operating costs, including labor.

The diagram above illustrates the major steps in a continuous process. The transesterification reaction is generally carried out in two reactors of the same capacity in series in order to obtain maximum conversion rate and the quality of esters, particularly high for ester fuels. This quality is enhanced by water washing against the current which eliminates the traces of catalyst, glycerol and methanol. Finally, drying of the ester is carried out on reduced pressure between 40 and 60 mbar to 140 ° C.

As for the processes operating in batch, methyl esters yields are between 98.5 and 99.4%. The characteristics of the products are substantially similar to those obtained with batch processes.

➤ Heterogeneous continuous process

Heterogeneous catalysis has significant advantages in terms of environmental friendliness. It meets the criteria associated with new concepts of "green chemistry" because the purity of the products obtained, combined with high yield synthesis, leads to an almost total

disappearance of discharges. Both transesterification reactors, installed in series so that theoretical yields approaching 100% are fixed bed reactors catalyst that operates continuously.

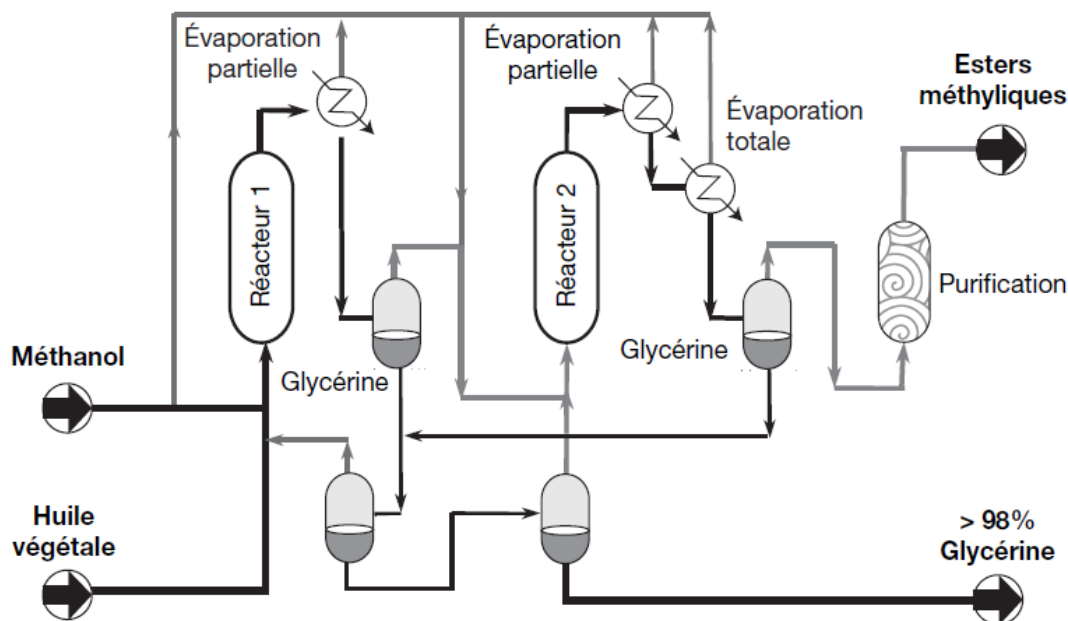

Figure 77 Schematic design of a heterogeneously catalyzed continuous process of EMHV (IFP process) (Ballerini, 2006)

The activation energy of the catalyst is relatively high; the temperatures for the reactions are much higher than those imposed in homogeneous catalysis. They are between 180 and 220 °C, with pressures between 40 and 60 bars.

The methanol/oil ratio is between 35 and 50% by weight. The mixture is introduced into the first reactor in accordance with a residence time of about an hour. The effluent, in which methyl ester is around 95%, is subjected to partial evaporation to remove excess alcohol. The ester content is greater than 98% by weight. The glycerin is separated by decantation; its purity is greater than 98%. The main impurity is water, initially present in the raw materials used.

### 15.3.6.2 Processes in development

Catalytic materials are very expensive. That is the reason why the new processes in development are non-catalytic ones. Here are two processes that seem to be interesting for the future.

#### ➤ BIOX process

University of Toronto proposed to use specific inert co solvents in order to generate an oil-rich one phase system. This principle is the base of the BIOX process. The tetra hydro furan for example solubilizes the methanol, so the alcohol is extremely few soluble in the triglyceride

phase. The result is a fast transesterification reaction, 5 to 10 min in average, and there are no catalyst residues in either the ester or the glycerol phase.

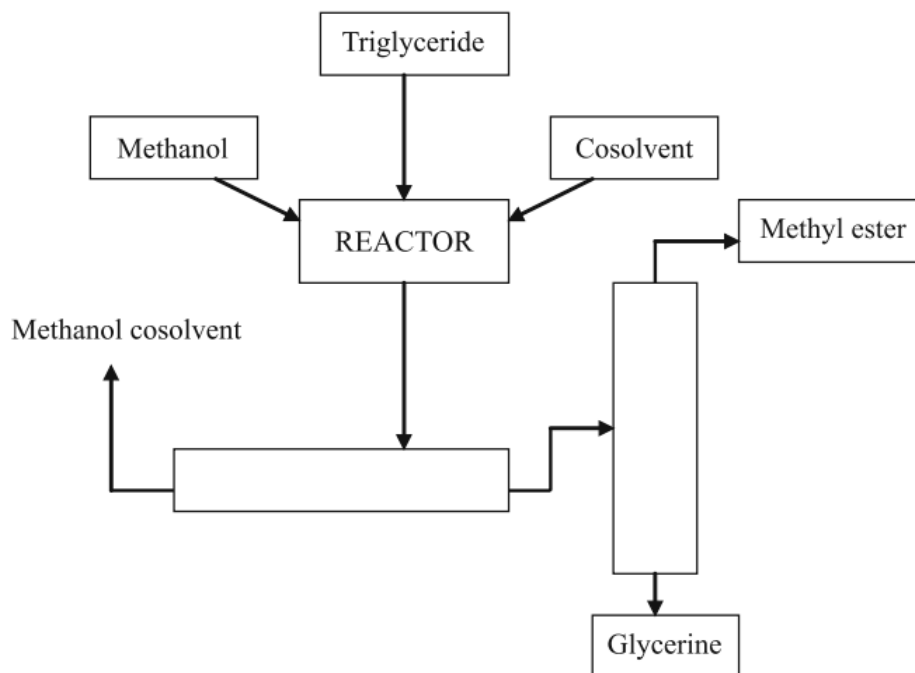

Figure 78 BIOX cosolvent process (Demirbas, 2008)

Nowadays, BIOX is a technology development company that is a joint venture of the University of Toronto Innovations Foundation and Madison Ventures Ltd. Base-catalysed transesterification (essentially transmethylation) of fatty acid to produce methyl esters is used in its process. The process is continuous and no specific feedstock is necessary. With this method, the developers think they could offer a cost competitive biodiesel overlook the petro diesel.

The main advantages are the use of an inert co solvent at ambient temperature and pressure. The co solvent also permits to overcome the problem of slow reaction times because of the low solubility of the alcohol in the triglycerides. It can be noticed that the co solvent must be eliminated from the process because of its possible toxicity.

#### ➤ Supercritical alcohol process

Today, another process using supercritical fluid is studied. A supercritical fluid is a substance whose temperature and pressure are above the critical point. As a consequence the gaseous and the liquid state cannot be distinguished and a single fluid phase is formed.

The lower value of the dielectric constant of methanol in the supercritical state seems to solve the problem associated with the two-phase nature of normal methanol/oil mixtures by forming a single phase. The idea of the use of supercritical methanol (SCM) to transesterification was firstly proposed by Demirbas, (2008).



To obtain methanol in supercritical state, the reaction requires temperature of 526 to 675 K and pressure of 35 to 60 Mbar (Demirbas, 2008). The high pressure reactor is an autoclave (batch process) in which the transesterification is occurred during the heating period. SCM method for transesterification is under development since 1998 and for the moment the optimum conditions are 623 K, 20 MPa and heating during 9 min. The advantages of this method are multiple: lower reaction time, more eco-friendly and less purification step. However, the use of high pressure and high temperature leads to a higher amount of energy.

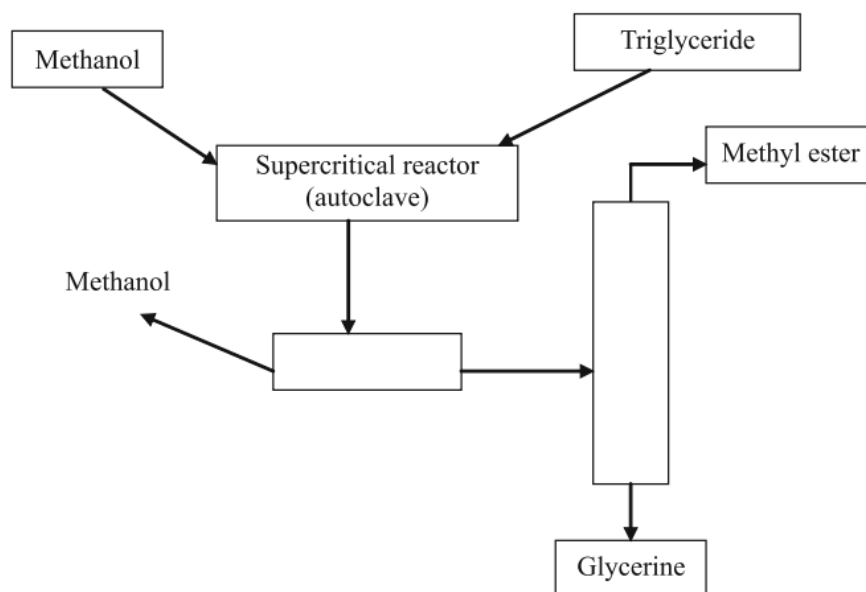

Figure 79 Supercritical transesterification process (Demirbas, 2008)

➤ In situ process

Harrington and D'Arcy-Evans developed this new type of process in 1985. To achieve this transesterification, the oilseeds are treated with a solution of methanol containing the catalyst, under ambient pressure and temperature. Before doing the reaction, the seeds are dried in order to reduce the quantity of alcohol that needs to be put. The mixture containing the solution of methanol and the seeds is heated under reflux during one to five hours. After this time, two layers are formed and the upper one containing the crude biodiesel is recovered, washed, dried and filtered in order to obtain the purified biodiesel. This method permits to obtain good results in terms of yield and avoid the step of isolation of the oil from the seeds. So, it permits to reduce the economical and energetic costs and optimize the productivity.

So, different methods which permit to produce biodiesel from *Jatropha curcas* were explained. It would be interesting to compare all of them following different criterions such as the energetic cost, the price of each equipment, the number of equipments... but, at the moment, no study has been done in that sense.

The homogeneous batch process, which was the one used for this study, is the one developed for the modeling step.

### 15.3.7 Study of homogeneous batch process

#### 15.3.7.1 The ESTERFIP Process

IFP has done extension in R&D work in the transesterification field with the aim of creating a product that would be suitable as an excellent substitute for diesel fuel. As a result, a new process called ESTERFIP was developed that allows the elimination of certain impurities from the product.

The ESTERFIP process was developed by IFP first on a laboratory scale, then tested in a pilot plant (1987) and demonstrated in a commercial plant that is operating satisfactorily since 1992 (capacity: 20000t/year). Originally, the design was developed for batch operation which is very suitable for small capacities and then further upgraded to continuous operation, an economically dictated choice for intermediate and large capacities.

In the case of biodiesel manufacturing, the main objective is to achieve the maximum possible conversion towards methylester in excess of 97%. This aim puts certain specific constraints on the reaction scheme, such as long hold-up time or eventually unreacted feed components recycling, involving a difficult separation between reagents and product.

The situation is also complicated by solubility problems. For example in the present case neither methanol is soluble in the starting material triglyceride nor the end products glycerin and fatty acid methyl esters are miscible, whereas methanol is soluble in fatty acid methyl esters. We can therefore expect different time dependent situations: at the beginning a two phase system followed by an almost complete solution. Then as soon as a considerable amount of glycerin is formed, a new two phase system is again prevailed.

The sequence of processing steps is as follows:

- Transesterification of the vegetable oil by dry methanol in presence of a basic catalyst
- Decantation to completely separate methyl esters from glycerin
- The ester phase is water washed and purified in a continuous operation in order to eliminate the last traces of catalyst particles; this step is very critical to avoid harmful deposits during the combustion in the diesel engine
- Vacuum evaporation of the methyl ester product to recover traces of methanol and water
- The raw glycerin recovered in the settler is evaporated, the main methanol removal step, neutralized, decanted to separate fatty acids, and finally completely freed from methanol.

IFP in its ESTERFIP process found the product properties below for the main product biodiesel and the by-product glycerin:

Table 27 Product properties (Demirbas, 2007)

Bio diesel (Methyl esters)	
Specific gravity	0,88
Flash point (°C)	55
Cetane number	49
Viscosity	7,52
Glycerin (by-product)	
Glycerin content (wt %)	> 80
Ash content (wt %)	< 10
Other organic compound (wt %)	< 2,5
Methanol content (wt %)	< 0,2
Water content (wt %)	< 10

We can now understand the environmental advantages of bio-diesel. The main distinctive features of bio-diesel versus conventional diesel fuel are:

- No sulfur;
- No aromatics;
- Presence of oxygen in the molecular composition;
- Renewable energy.

### 15.3.7.2 Characteristics of the streams

In order to model the transesterification, it was decided to focus on the global inputs and outputs of the process. This following black box shows two input streams, one for the reagents, the *Jatropha* oil cultivated in Mali and the methanol, and the other for the catalyst. We consider only one output stream containing the main product biodiesel and other secondary products. Some external source of energy is needed in order to conduct the reaction.

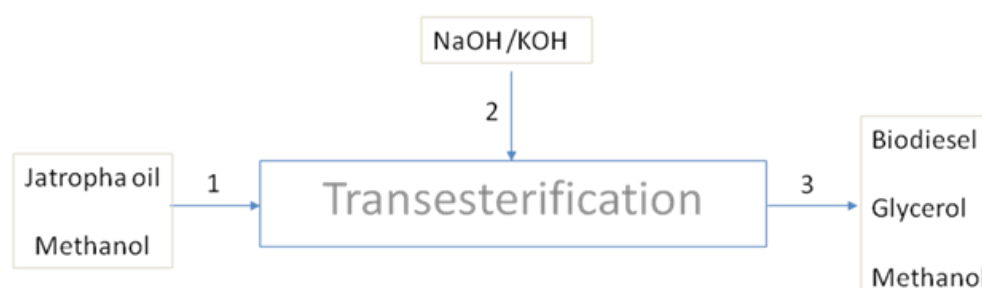

Figure 80 Black box of the process for the reaction of transesterification

All the streams are characterized in the following tables, showing their function, their composition and their physical state.

Table 28 Description of the input and output streams

N° stream	1
Nature	Input
Function	Reagent
Physical state	Liquid
Temperature (°C)	25
Pressure (bar)	1
Mol composition	%
Oil	85.7
Methanol	14.3
N° stream	2
Nature	Input
Function	Catalyst
Physical state	Solid
Temperature (°C)	25
Pressure (bar)	1
Mass composition	%
KOH or NaOH	0.5
N° stream	3
Nature	Output
Function	Product
Temperature (°C)	50
Pressure (bar)	2.5
Composition	%
Biodiesel	95
Methanol	3
Glycerol	2

For the output stream, the results are those which are obtained at the end of all the process. Nevertheless, in our case, as explained previously we work in black box and we make a balance only on the transesterification step. So, the percentage in biodiesel is less high and the percentages in methanol and glycerin on the contrary is higher. This is due to all the steps of purification after the transesterification reaction.

### 15.3.7.3 Balances

The reaction of transesterification is the following one:

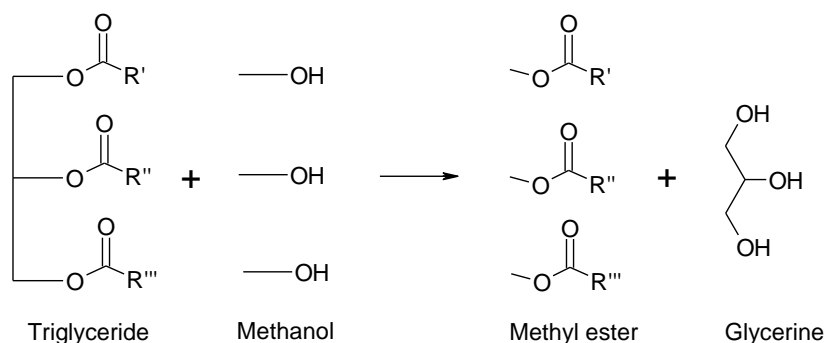

Figure 81 Classic reaction of transesterification

To make balances, we need to fix some parameters and hypothesis:

- Flow rate of Jatropha oil in the process input equals to 1000kg ;
- Methanol / oil molar ratio equals to 6:1 ;
- Catalyst amount of 0.5% in weight ;
- Conversion ratio of oil equals to 97%.

We have to know the mass molar of the Jatropha oil. According to a study, it is possible to calculate the molar mass. First, we have the composition of the Jatropha oil based on the work of Liu et al., (2011). It may be noticed that some other works were carried concerning the composition of the Jatropha oil such as the one of Leung and leung, (2010) or the one of Jain and Sharma, (2010).

For this study, we consider that only, the triglyceride, diglyceride and monoglyceride count into the composition of the Jatropha oil. But, indeed, it is only 85% of the composition of the Jatropha oil. We made a hypothesis: we decided to not include the free fatty acid (FFA). Actually, in the process, there are two steps the pre esterification in which the FFAs in the oil are converted to methyl ester and then, take place the esterification with the triglyceride and the methanol. But as explain in the mechanism triglycerides give diglycerides and finally monoglycerides so we can consider these three components as the reagents in the Jatropha oil. The second hypotheses made are that the molar mass of mono, di and tri glycerides are equals because we do not have enough data to make the calculation.

Table 29 Composition and properties of Jatropha oil (Liu et al., 2011)

composition (wt %)	jatropha oil
triglyceride	80.4
diglyceride	2.1
monoglyceride	2.5
free fatty acid	14.9
acid value (mg of KOH/g of oil)	27.2
iodine value (g of I <sub>2</sub> /100 g of oil)	105
density at 25 °C (g/mL)	0.92
viscosity at 30 ° (mPa/s)	49.4

Then it is possible to calculate the molar mass of this Jatropha oil. We called this oil: Jatropha oil-mono, di, tri glycerides (Jatropha oil MDT glycerides) in order to keep in mind the simplifying hypothesis.

Table 30 Composition in triglyceride in *Jatropha* oil (Liu et al., 2011)

formula	C number of ester group <sup>b</sup>	no. of C=C double bonds	wt %
C <sub>51</sub> H <sub>98</sub> O <sub>6</sub>	C16+C16+C16	0	0.6
C <sub>51</sub> H <sub>96</sub> O <sub>6</sub>	C16+C16+C16	1	0.2
C <sub>53</sub> H <sub>102</sub> O <sub>6</sub>	C16+C16+C18	0	1.7
C <sub>53</sub> H <sub>100</sub> O <sub>6</sub>	C16+C16+C18	1	12.6
C <sub>53</sub> H <sub>98</sub> O <sub>6</sub>	C16+C16+C18	2	8.4
C <sub>53</sub> H <sub>96</sub> O <sub>6</sub>	C16+C16+C18	3	0.3
C <sub>55</sub> H <sub>106</sub> O <sub>6</sub>	C16+C18+C18	0	0.5
C <sub>55</sub> H <sub>104</sub> O <sub>6</sub>	C16+C18+C18	1	9.5
C <sub>55</sub> H <sub>102</sub> O <sub>6</sub>	C16+C18+C18	2	19.2
C <sub>55</sub> H <sub>100</sub> O <sub>6</sub>	C16+C18+C18	3	16.5
C <sub>55</sub> H <sub>98</sub> O <sub>6</sub>	C16+C18+C18	4	1.9
C <sub>57</sub> H <sub>110</sub> O <sub>6</sub>	C18+C18+C18	0	0.6
C <sub>57</sub> H <sub>108</sub> O <sub>6</sub>	C18+C18+C18	1	6.3
C <sub>57</sub> H <sub>106</sub> O <sub>6</sub>	C18+C18+C18	2	9.7
C <sub>57</sub> H <sub>104</sub> O <sub>6</sub>	C18+C18+C18	3	9.5
C <sub>57</sub> H <sub>102</sub> O <sub>6</sub>	C18+C18+C18	4	2.2
C <sub>57</sub> H <sub>100</sub> O <sub>6</sub>	C18+C18+C18	5	0.3

Table 31 Composition of Triglyceride in *Jatropha* Oil from Indonesia

formula	wt (%)	molar mass (g/mol)	wt*molar mass
C <sub>51</sub> H <sub>98</sub> O <sub>6</sub>	0,6	806	4,84
C <sub>51</sub> H <sub>96</sub> O <sub>6</sub>	0,2	804	1,61
C <sub>53</sub> H <sub>102</sub> O <sub>6</sub>	1,7	834	14,18
C <sub>53</sub> H <sub>100</sub> O <sub>6</sub>	12,6	832	104,83
C <sub>53</sub> H <sub>98</sub> O <sub>6</sub>	8,4	830	69,72
C <sub>53</sub> H <sub>96</sub> O <sub>6</sub>	0,3	828	2,48
C <sub>55</sub> H <sub>106</sub> O <sub>6</sub>	0,5	862	4,31
C <sub>55</sub> H <sub>104</sub> O <sub>6</sub>	9,5	860	81,70
C <sub>55</sub> H <sub>102</sub> O <sub>6</sub>	19,2	858	164,74
C <sub>55</sub> H <sub>100</sub> O <sub>6</sub>	16,5	856	141,24
C <sub>55</sub> H <sub>98</sub> O <sub>6</sub>	1,9	854	16,23
C <sub>57</sub> H <sub>110</sub> O <sub>6</sub>	0,6	890	5,34
C <sub>57</sub> H <sub>108</sub> O <sub>6</sub>	6,3	888	55,94
C <sub>57</sub> H <sub>106</sub> O <sub>6</sub>	9,7	886	85,94
C <sub>57</sub> H <sub>104</sub> O <sub>6</sub>	9,5	884	83,98
C <sub>57</sub> H <sub>102</sub> O <sub>6</sub>	2,2	882	19,40
C <sub>57</sub> H <sub>100</sub> O <sub>6</sub>	0,3	856	2,57
		Total	859,05

Thanks to this table, we can calculate the molar mass of the oil *Jatropha*, the FFA are considered as negligible. Moreover, by conservation we can calculate the molar mass of the corresponding methyl ester:

$$M_{\text{methyl ester}} = (M_{\text{Jatropha oil MDT glycerides}} + 3 \cdot M_{\text{methanol}} - M_{\text{glycerin}}) / 3$$

Table 32 Molar mass of the inputs and outputs of the reaction

	Molar mass (g/mol)
Jatropha oil MDT glycerides	859,05
Methanol	32
Glycerin	92
Methyl ester	266,35

Hence, we made a balance:

3 MeOH	+	1 Jatropha oil MDT glycerides	→	3 Methylester	+	1 Glycerol
$N_{MeO}$		$N_{oilO}$		0		0
$N_{MeO} - 3 * \xi$		$N_{oilO} - \xi$		$3 * \xi$		$\xi$

**Balance 1: use of the advancement rate**

But we know only the conversion rate, not the advancement of the reaction, so we use the relation between them:  $\xi = \tau * N_{oilO}$

With:

- $\xi$  : advancement rate ;
- $\tau$  : conversion rate of the transesterification equals to 97% ;
- $N_{oilO}$  : initial quantity of oil Jatropha;

So finally, we can make a balance thanks to the conversion rate:

3 MeOH	+	1 Jatropha oil MDT glycerides	→	3 Methylester	+	1 Glycerol
$N_{MeO}$		$N_{oilO}$		0		0
$N_{MeO} - 3 * \tau * N_{oilO}$		$N_{oilO} * (1 - \tau)$		$3 * \tau * N_{oilO}$		$\tau * N_{oilO}$

**Balance 2: use of the conversion rate**

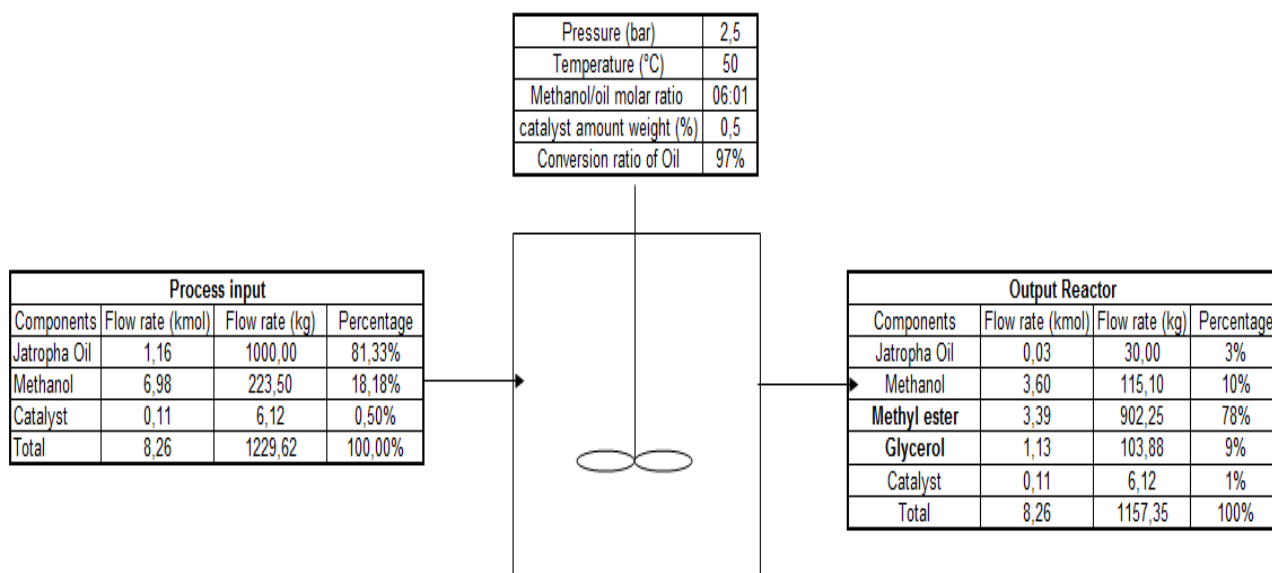

Figure 82 Balances with a conversion ratio equals to 97%

The results seem correct because we have the conservation of the number of moles and at the end we obtain between 78% of biodiesel which is a good rate. After the steps of purification, this ratio is better and probably close to 97%.

## 15.4 THERMODYNAMIC AND UNIT OPERATION MODEL

We are going to determine the thermodynamic model for a production unit of biofuel using oil and an alcalin catalyst.

- Liquid phase

The system contains polar components such as the methanol and the glycerol, this promotes high interactions in the liquid phase.

- Vapor phase

The 2.5 bars operating pressure is considered as low, so the behavior of the vapor phase can be assimilated as ideal gas.

- Thermodynamic model

Thanks to these two considerations, we can consider a heterogeneous approach. Nevertheless, any equilibrium data for the binaries of the system are available, so we choose a predictive model such as UNIFAC. Finally, UNIFAC Dortmund modified is chosen.

However, UNIFAC decompositions are not available for all the components. For instance those of the Jatropha oil and of the inorganic compounds are unknown. That is why, some hypothesis are made:

- First of all, the UNIFAC decomposition of the inorganic compounds can be assimilated to these of the water. This hypothesis consists in not consider the influence of the pH on the equilibrium. This hypothesis is realistic because of the low percentage in inorganic compounds; indeed those represent only the catalyst.
- Concerning the Jatropha oil, its decomposition is obtained thanks to its chemical structure.

To explain this we can quote an example detailed for the production of biodiesel from colza oil called triolein, its formula is  $C_{57}H_{104}O_6$ .

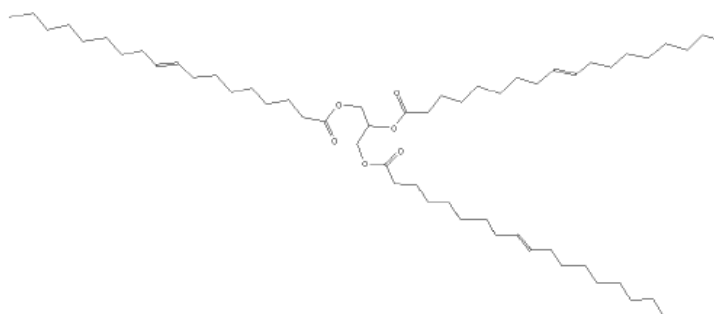

Figure 83 Chemical structure of the triolein

Then, when the structure is known it is easy to decompose in groups and we obtained the flowing UNIFAC Dortmund decomposition for the triolein:



Table 33 UNIFAC Dortmund decomposition for the triolein

Group	Frequency	%
CH=CH	3	5,9%
CH <sub>2</sub>	41	80,4%
CH	1	2,0%
CH <sub>3</sub>	3	5,9%
CH <sub>2</sub> COO	3	5,9%

So, finally we use the UNIFAC Dortmund thermodynamic model and we create the compound Jatropa oil in the data basis knowing its structure. Hence, we could model the system thanks to Prosim for example. Nevertheless, we encounter another problem because the process is a batch process. However, Prosim Plus is used for continuous processes, so maybe the use of ProsimBatch or Batchmod is more adapted.

#### 15.4.1 Different section of given apparatus

Details of the apparatus and equipments are presented in this section. It is to be noted that this particular model is not intended to be used in equipment detailed design, manufacturing or even producing engineering documents without further review by a process engineer.

##### ➤ Secondary reactor:

- The main reaction is a total reaction of neutralization of the catalyst (hydrochloric acid + Catalyst = Water + Potassium Chloride).
- This is a complete reaction and takes place at 60° C and 1 bar.
- Parallel to the secondary reaction there took place a complete parasitic reaction for free fatty acids formation (hydrochloric acid + oleic acid + Soap = Potassium Chloride).

##### ➤ Primary settler/decanter:

- We considered that this decanter could be likened to a liquid equilibrium phase, liquid at room temperature and atmospheric pressure (25° C and 1 bar).
- The thermodynamic model chosen to represent the liquid-liquid equilibrium is modified UNIFAC (Dortmund) 1993 model, which takes into account the interactions between different functional groups of inputs into the settler/decanter
- Simulis function used to calculate the liquid-liquid equilibrium is stCALFIITP (function for calculating a liquid-liquid flash temperature and pressure).

##### ➤ Secondary settler/decanter:

- We assume again that the decanter can be likened to a liquid equilibrium phase or level, liquid at room temperature and atmospheric pressure (25° C and 1 bar).

- The thermodynamic model chosen to represent the liquid-liquid equilibrium is modified UNIFAC (Dortmund) 1993 model (Gmehling et al., 1993) for the same reasons as those set out in the previous "primary settler/decanter.
- Simulis function used to calculate the liquid-liquid equilibrium is stCALFIITP.

➤ **Washing column:**

- We put a hypothesis that this column of washing may be likened to a column of single layered liquid-liquid extraction (flash liquid - liquid) at room temperature and atmospheric pressure (25° C and 1 bar).
- The thermodynamic model chosen to represent the liquid-liquid equilibrium is modified UNIFAC (Dortmund) 1993 model which takes into account the interactions between different functional groups for inputs in washing column with water.
- Simulis function used to calculate the liquid-liquid equilibrium is stCALFIITP (function for calculating a liquid-liquid flash at given temperature and pressure).

➤ **Distillation column for biodiesel:**

- The separation between the different components which enters the column is simple; we assume that the distillation column could be represented by a stage level of vapor-liquid equilibrium (liquid-vapor flash).
- The distillation column is operated at 150° C and 0.1 bar in order to have the best possible separation without decomposing biodiesel (decomposition that occurs beyond 170° C)
- Simulis function used to calculate the liquid-liquid equilibrium is stCALFlashTP (function for calculating a liquid-vapor flash at given temperature and pressure).

➤ **Glycerin distillation column:**

- As in the previous case, the separation between the different constituents of the column is simple; we assume that the distillation column can be represented by a stage level of vapor-liquid equilibrium (liquid-vapor flash).
- The distillation column is operated at 65° C and 0.1 bars in order to have the best possible separation without decomposing the glycerin which takes place above 170° C.
- Simulis function used to calculate the liquid-liquid equilibrium is again stCALFlashTP (function for calculating a liquid-vapor flash at given temperature and pressure).

### 15.4.2 Separation of glycerin and methyl ester

This output stream of the reactor is then subjected to decantation for the separation of glycerol from other constituents. This step is quite easy because of the immiscibility of glycerol and methyl ester. Methanol is itself divided between the two currents leaving the decanter. Soap with glycerin is driven while the remaining traces of triglycerides are carried in the stream of methyl ester. The catalyst (KOH) is carried out along with glycerin.

#### 15.4.2.1 Washing through water stream

This step is intended to remove the last traces of glycerol from current biodiesel in way to have a possible high level purification for biodiesel as an output in the distillation column. To do this we have to deal with washing against water stream. Thus the stream in output contains not only biodiesel, but also water and methanol. The water stream contains traces of glycerol and methanol.

#### 15.4.2.2 Biodiesel distillation column

This distillation column allows us to recover a stream of biodiesel (> 99.5 wt. %) with high purity. Indeed, the separation of water-methanol-methyl ester is very easy because of the very large differences in boiling temperatures of the individual components. In the column head, we thus recovering a stream containing primarily water and methanol, and in the bottom, we recover a stream containing very pure biodiesel small traces of water and methanol.

#### 15.4.2.3 Neutralization reactor

The stream that contains glycerin (and catalyst) is to be introduced into a second reactor to undergo a neutralization reaction with hydrochloric acid. This step is vital because if one want to recover glycerin, it is necessary to perform a distillation step which requires a stream with a neutral pH to avoid damaging the distillation column, and the absence of soap.

Neutralization reaction is given below:

##### *Equation 10 Neutralization reaction*

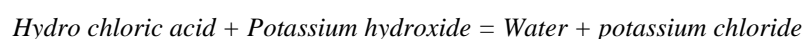

In parallel to this neutralization reaction there occurred a second reaction forming free fatty acids by reaction with hydrochloric acid with soap. The reaction is as follows:

##### *Equation 11 Reaction for the formation of fatty acids*



### 15.4.3 Separation of Glycerin and free fatty acids

In order to obtain a purest possible glycerin stream in the distillation column outlet, it is necessary to perform a decantation process to separate the free fatty acid and glycerin. Because of the assumption that the *Jatropha curcas* oil that enters the transesterification process consists only of triglycerides, this decanter is not of great relevance (since fatty acids are derived when only the secondary reaction in the neutralization reactor takes place). However, in the real case (where the oil *Jatropha curcas* is also composed of fatty acids), this decanter is very vital for this whole phenomena.

### 15.4.4 Distillation of glycerin

The last device present in the method is a distillation column to separate the methanol/water mixture of the glycerol. A condition for the recovery of glycerin is to have a mass purity of at least 85 wt.% glycerin. The stream in upper column (water and methanol) is treated by its own.

## 15.5 KINETICS OF TRANSESTERIFICATION

In this part, we tackle the question of the kinetics of the transesterification of refined *Jatropha curcas* oil.

### 15.5.1 Kinetic model 1 (Om Tapanes et al., 2008)

The kinetic study carried out was in accordance to the following operating condition:

Law determined in mentioned publication is given as under:

$$r_{TG} = -k_1 \cdot C_{TG}^{\alpha}$$

Where:  $r_{TG}$  is related to transesterification reaction speed (mol/L/h)

$k_1$  kinetic constant (h<sup>-1</sup>)

$\alpha$  kinetic law exponent (no unit)

$C_{TG}$  concentration in triglycéride (mol/L) at a period t

Table 34 operating condition for kinetic model-1

Initial concentration in triglyceride $C_{TG}^{\circ}$ (mol/L)	0,74
Molar ratio methanol/ <i>Jatropha curcas</i> oil	9
Temperature (°C)	45
Mass fraction of catalyzer (NaOCH <sub>3</sub> )	0,008
Pressure (bar)	NA

The parameters of this law have been experimentally established under the previous operating conditions. They are summarized in the following table:

Table 35 Parameters of kinetic model-1

$k_1$ ( $\text{h}^{-1}$ )	2,4364
$\alpha$	2,403

The rate of conversion of triglyceride at interval  $t$  is:

Equation 12

$$X_{TG} = \frac{C_{TG}^{\circ} - C_{TG}}{C_{TG}^{\circ}}$$

Stepwise integration has been considered in Excel for time period reports. Time period for each sep is  $\Delta t = 0,01$  h

Figure 84 and Figure 85 show the results obtained by this method of integration for triglyceride concentration and triglyceride conversion rate as a function of time.

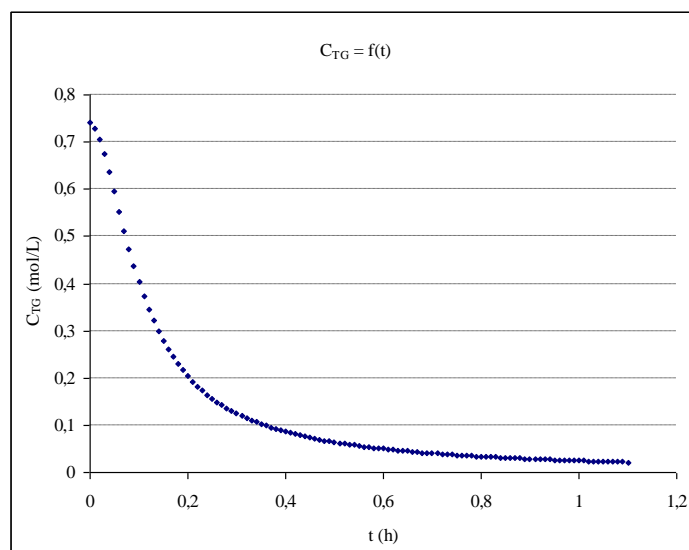

Figure 84 Triglyceride concentration versus time for the kinetic model

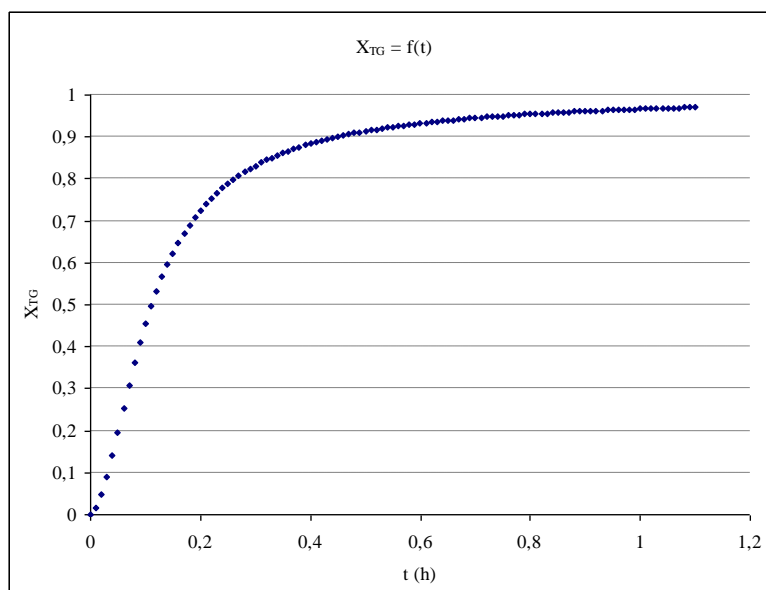

Figure 85 Conversion rate for triglyceride over time period of kinetic model 1

### 15.5.2 Kinetic Model 2 (Jain and sharma, 2010)

For this model, the operating conditions are as follows (Table 36):

Table 36 Operating condition for kinetic model-2

Initial concentration in triglyceride $C_{TG}^0$ (mol/L)	0,74
Volume ratio methanol/Jatropha curcas oil	3/7
Temperature (°C)	50
Mass fraction of catalyzer (NaOH)	0,01
Pressure (bar)	1

Law determined in mentioned publication is given as under:

$$r_{TG} = \exp(-A \cdot \ln(C_{TG}) + B)$$

where:  $r_{TG}$  is related to transesterification reaction speed (mol/L/h)

A and B are constants (no units)

$C_{TG}$  concentration in triglycéride (mol/L) at a period t

The parameters for this law have been experimentally established under the previous operating conditions. They are summarized in the following table:

Table 37 Parameters for kinetic model-2

A	-1,0714
B	2,868

Again stepwise integration has been considered in Excel for time period reports. Time period for each sep is  $\Delta t = 0,01$  h. Figure 86 and Figure 87 below show the results obtained by this method of integration for triglyceride concentration and triglyceride conversion rate as a function of time.

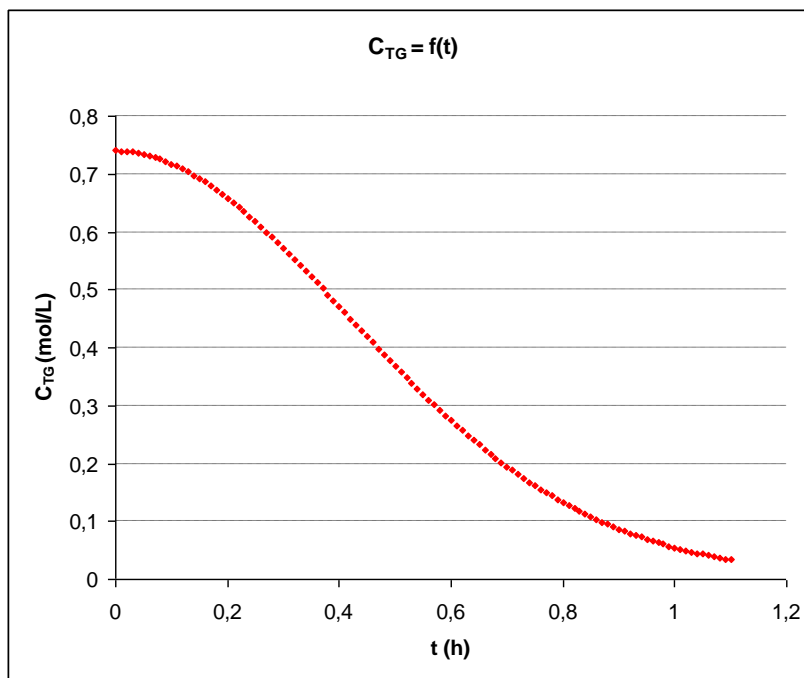

Figure 86 Triglyceride concentration versus time for the kinetic model-2

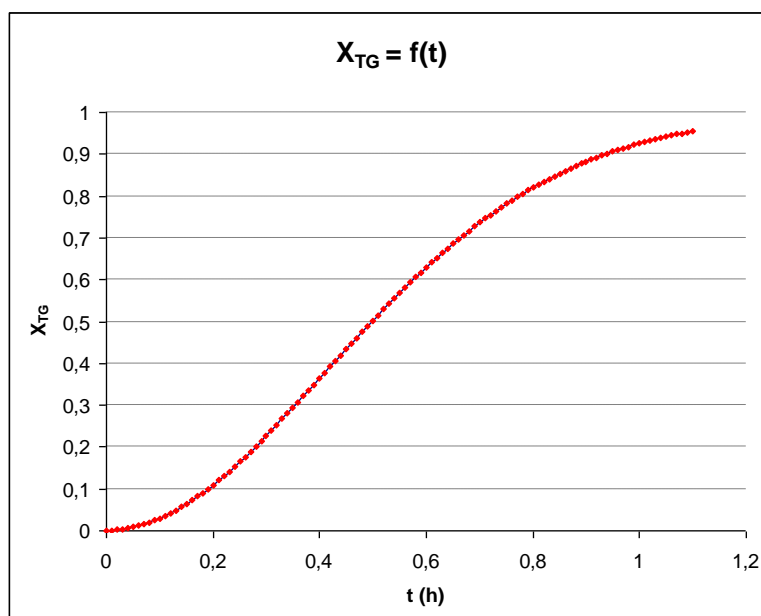

Figure 87 Conversion rate for triglyceride over time period of kinetic model-2

### 15.5.3 Critical analysis of results

Neither of these two kinetic models matches the operating conditions that we have considered and were part of ESTERFIP process. ESTERFIP data are summarized in the following table (Table 38):

Table 38 Operating conditions for ESTERFIP process under study

Initial concentration in triglyceride $C_{TG}^{\circ}$ (mol/L)	NA
Molar ratio methanol/Jatropha curcas oil	6
Temperature ( $^{\circ}$ C)	60
Mass fraction of catalyzer (KOH)	0,0045
Pressure (bar)	2,5

However, these kinetic models are currently the only kinetic data available for the transesterification of Jatropha curcas oil. They can give us an order of magnitude of the reaction time which is necessary to obtain a conversion rate of 97% triglyceride (conversion rate that we considered in our Excel simulators and Prosim Plus). The order of magnitude for this conversion rate is about 1h20 min but further studies are needed if one wants to develop a future production unit based on ESTERFIP process.

Information related to the kinetics of transesterification found in the literature is quite different from ESTERFIP process that we studied. Only an order for the time interval necessary for the conversion of 97% Jatropha curcas oil could be determined. Experimental studies in the operating conditions of ESTERFIP process are studied to achieve the establishment of a possible future biodiesel production unit. This information is essential for the scheduling of batch ESTERFIP process.







## 15.7 MULTIPLE SCREEN SHOTS OF SIMLCA

IMPACT 2002+

GLOBAL PROCESS

OUTPUT (YEAR 1 to 30)

C140

GLOBAL PROCESS

OUTPUT (YEAR 1 to 30)

Total list to 30th year: Nurseries, transplantation & Non-renewable energy	Unit	Fertilizer	Fertilizer P	Fertilizer K	Water	Meter
Non-renewable energy	MJ	3878.88	18388.50	10183.21	0.00	0.00
Global warming	kg CO2FU	552.44	1893.77	693.23	0.00	0.0
Respiratory inorganics	kg	4.21	2.28	2.41	0.00	0.0
Terrestrial ecotoxicity	kg TEG	4677.06	1073.65	1073.24	0.00	0.0
Non-Carcinogen	kg	14.28	104.82	10.24	0.00	0.0
Carcinogen	kg	45.30	24.30	10.70	0.00	0.0
Terrestrial acidfauna	kg SO2FU	110.61	17.34	5.73	0.00	0.0

Total list to 30th year: Transport	Unit	Train	Barge	Lorry	Total
Non-renewable energy	MJ	13055.11	107436.19	4750.23	161041.53
Global warming	kg CO2FU	65.14	1905.51	277.18	2049.83
Respiratory inorganics	kg	0.21	71.23	0.43	71.87
Terrestrial ecotoxicity	kg TEG	6925.34	88552.32	6147.36	100025.02
Non-Carcinogen	kg	11.01	62.25	0.70	74.96
Carcinogen	kg	0.00	35.89	0.44	36.33
Terrestrial acidfauna	kg SO2FU	20.38	601.51	13.45	641.34

Total list to 30th year: Refining	Unit	Fertilizer	Fertilizer P	Fertilizer K	Water	Meter
Non-renewable energy	MJ	0.00	0.00	0.00	0.00	1682
Global warming	kg CO2FU	0.00	0.00	0.00	0.00	0.0
Respiratory inorganics	kg	0.00	0.00	0.00	0.00	0.0
Terrestrial ecotoxicity	kg TEG	0.00	0.00	0.00	0.00	0.0
Non-Carcinogen	kg	0.00	0.00	0.00	0.00	0.0
Carcinogen	kg	0.00	0.00	0.00	0.00	0.0
Terrestrial acidfauna	kg SO2FU	0.00	0.00	0.00	0.00	2.0

F39 UNIT

**DAMAGE ASSESSMENT OR ENDPOINT SHEET**

DATA FROM SIMAPPO

DAMAGE CATEGORY	HUMAN HEALTH	UNIT	END POINT	NORMALIZATION	UNIT
Carcinogenes	2,88E-06	DALY / kg C2H3Cl eq	Human health	1,4E-02	PT/DALY
Non-Carcinogenes	2,88E-06	DALY / kg C2H3Cl eq	Ecosystem health	7,88E-06	PT/PO2.m3.g
Respiratory inorganics	2,88E-06	DALY / kg PM2.5 eq	Climate change	1,88E-06	PT/kg CO2 eq
Resources	6,98E-06	PT/MJ.primax	Resources	6,98E-06	PT/MJ.primax

DAMAGE CATEGORY	ECOSYSTEM QUALITY	UNIT
Terrestrial ecotoxicity	3,93E-03	PO2.m3.g / kg TEG water
Terrestrial acidfauna	1,84E-06	PO2.m3.g / kg SO2 eq

DAMAGE CATEGORY	CLIMATE CHANGE	UNIT
Global warming	1,88E-06	kg CO2 eq / kg CO2 eq

DAMAGE CATEGORY	RESOURCES	UNIT
Non-renewable energy	1,88E-06	MJ.primax / MJ.primax

FIRST STEP

DAMAGE CATEGORY	HUMAN HEALTH	UNIT
Carcinogenes	4,18E-02	PT/FU
Non-Carcinogenes	3,63E-02	PT/FU
Respiratory inorganics	2,85E-06	PT/FU

DAMAGE CATEGORY	ECOSYSTEM QUALITY	UNIT
Terrestrial ecotoxicity	7,88E-02	PT/FU
Terrestrial acidfauna	7,88E-02	PT/FU

DAMAGE CATEGORY	CLIMATE CHANGE	UNIT
Global warming	2,24E-06	PT/FU

DAMAGE CATEGORY	RESOURCES	UNIT
Non-renewable energy	3,86E-06	PT/FU

SECOND STEP

NORMALIZATION	UNIT	
Human health	3,63E-06	PT/FU
Ecosystem health	4,63E-01	PT/FU
Climate Change	2,24E-06	PT/FU
Resources	3,86E-06	PT/FU

F39 UNIT

DAMAGE CATEGORY	ECOSYSTEM QUALITY	UNIT
Carcinogenes	3,86E-02	PT/FU
Non-Carcinogenes	3,43E-02	PT/FU
Respiratory inorganics	2,85E-06	PT/FU

DAMAGE CATEGORY	CLIMATE CHANGE	UNIT
Global warming	3,26E-06	PT/FU

DAMAGE CATEGORY	RESOURCES	UNIT
Non-renewable energy	3,86E-06	PT/FU

IMPACT 2002+ METHOD END POINT FIGURE

Legend: Resources, Climate Change, Human Health

## 15.8 TABULATED RESULTS FROM SIMLCA

Table 40 Midpoint impacts (Impact 2002+) for the production of 1MJ biodiesel (methylester) in function to conversion rate crude Jatropha oil in methylester (before coupling of process simulator and LCA)

	Conversion rate	97%	92%	87%	82%	77%	72%	67%	62%	57%	52%	50%
Non-renewable energy	MJ primary/FU	11,8192305	Not available without coupling									
Global warming	kg CO2/FU	0,56299574										
Respiratory inorganics	kg ethylene/FU	0,00073606										
Terrestrial ecotoxicity	kg TEG soil/FU	6,71264349										
Non-Carcinogens	kg C2H3Cl/FU	0,00421741										
Carcinogens	kg C2H3Cl/FU	0,00518742										
Terrestrial acidification/nutrition	kg SO2/FU	0,02395843										

Table 41 Midpoint impacts (Impact 2002+) for the production of 1MJ biodiesel (methylester) in function to conversion rate crude Jatropha oil in methylester (without associated avoided impact of glycerin) (After coupling of process simulator and LCA)

impacts évit allocation	UF											
non	1,00E+00	MJ du mélange (biodiesel + huile de Jatropha brute non estérifiée)										
Absolus	Taux de conv	97%	92%	87%	82%	77%	72%	67%	62%	57%	52%	50%
Non-renewable energy	MJ primary/FU	1,62E+01	1,62E+01	1,61E+01	1,61E+01	1,60E+01	1,60E+01	1,60E+01	1,59E+01	1,59E+01	1,59E+01	1,58E+01
Global warming	kg CO2/FU	7,34E-01	7,31E-01	7,29E-01	7,27E-01	7,25E-01	7,23E-01	7,21E-01	7,19E-01	7,17E-01	7,15E-01	7,15E-01
Respiratory inorganics	kg ethylene/FU	7,70E-04	7,70E-04	7,69E-04	7,69E-04	7,68E-04	7,68E-04	7,67E-04	7,67E-04	7,67E-04	7,67E-04	7,67E-04
Terrestrial ecotoxicity	kg TEG soil/FU	6,81E+00	6,80E+00	6,80E+00	6,79E+00	6,79E+00	6,78E+00	6,78E+00	6,78E+00	6,77E+00	6,77E+00	6,77E+00
Non-Carcinogens	kg C2H3Cl/FU	6,29E-03	6,29E-03	6,29E-03	6,29E-03	6,28E-03	6,28E-03	6,28E-03	6,28E-03	6,28E-03	6,28E-03	6,28E-03
Carcinogens	kg C2H3Cl/FU	6,40E-03	6,39E-03	6,37E-03	6,36E-03	6,35E-03	6,34E-03	6,33E-03	6,32E-03	6,31E-03	6,30E-03	6,30E-03
Terrestrial acidification/nutrition	kg SO2/FU	2,52E-02	2,52E-02	2,52E-02	2,51E-02	2,51E-02	2,51E-02	2,51E-02	2,51E-02	2,51E-02	2,51E-02	2,51E-02

Table 42 Midpoint impacts (Impact 2002+) for the production of 1MJ biodiesel (methylester only) in function to conversion rate crude Jatropha oil in methylester (without associated avoided impact of glycerin) (After coupling of process simulator and LCA)

impacts évit	allocation	UF										
non	1,00E+00	MJ de biodiesel										
Absolus	Taux de conv	97%	92%	87%	82%	77%	72%	67%	62%	57%	52%	50%
Non-renewa	MJ primary/F	1,62E+01	1,71E+01	1,80E+01	1,91E+01	2,03E+01	2,16E+01	2,32E+01	2,50E+01	2,71E+01	2,97E+01	3,08E+01
Global warm	kg CO2/FU	7,35E-01	7,73E-01	8,15E-01	8,62E-01	9,16E-01	9,77E-01	1,05E+00	1,13E+00	1,22E+00	1,34E+00	1,39E+00
Respiratory i	kg ethylene/F	7,72E-04	8,13E-04	8,60E-04	9,12E-04	9,70E-04	1,04E-03	1,11E-03	1,20E-03	1,31E-03	1,43E-03	1,49E-03
Terrestrial e	kg TEG soil/F	6,82E+00	7,19E+00	7,60E+00	8,06E+00	8,58E+00	9,17E+00	9,85E+00	1,06E+01	1,16E+01	1,27E+01	1,32E+01
Non-Carcino	kg C2H3Cl/FU	6,31E-03	6,65E-03	7,03E-03	7,45E-03	7,94E-03	8,49E-03	9,12E-03	9,85E-03	1,07E-02	1,17E-02	1,22E-02
Carcinogens	kg C2H3Cl/FU	6,41E-03	6,75E-03	7,12E-03	7,55E-03	8,02E-03	8,57E-03	9,19E-03	9,92E-03	1,08E-02	1,18E-02	1,23E-02
Terrestrial a	kg SO2/FU	2,53E-02	2,66E-02	2,81E-02	2,98E-02	3,17E-02	3,39E-02	3,65E-02	3,94E-02	4,28E-02	4,69E-02	4,88E-02

Table 43 Midpoint impacts (Impact 2002+) for the production of 1MJ biodiesel (methylester + crude Jatropha oil) in function to conversion rate crude Jatropha oil in methylester (with the associated avoided impact of glycerin) (After coupling of process simulator and LCA)

impacts évit	allocation	UF										
oui	100%	MJ du mélange (biodiesel + huile de Jatropha brute non estérifiée)										
Absolus	Taux de conv	97%	92%	87%	82%	77%	72%	67%	62%	57%	52%	50%
Non-renewa	MJ primary/F	16,1413142	16,0989089	16,0574066	16,0168849	15,9774274	15,939125	15,9020782	15,8663959	15,832214	15,7996689	15,7871473
Global warm	kg CO2/FU	0,73212763	0,72988302	0,72768207	0,7255284	0,72342582	0,7213785	0,71939101	0,71746831	0,71561653	0,71384183	0,71315524
Respiratory i	kg ethylene/F	0,00076939	0,00076885	0,00076833	0,00076785	0,0007674	0,00076699	0,00076663	0,00076631	0,00076605	0,00076585	0,00076578
Terrestrial e	kg TEG soil/F	6,79077718	6,78501762	6,77952177	6,77431849	6,769439	6,764918	6,76079441	6,75711103	6,75392274	6,75128497	6,75039978
Non-Carcino	kg C2H3Cl/FU	0,00625802	0,00625492	0,00625204	0,0062494	0,00624704	0,00624499	0,00624328	0,00624194	0,00624104	0,00624062	0,0062406
Carcinogens	kg C2H3Cl/FU	0,0063783	0,00636563	0,00635328	0,00634127	0,00632963	0,00631841	0,00630763	0,00629735	0,0062876	0,00627845	0,00627497
Terrestrial a	kg SO2/FU	0,0251844	0,02516506	0,02514667	0,02512934	0,02511319	0,02509833	0,02508492	0,02507311	0,0250631	0,0250551	0,02505251

**Table 44** Midpoint impacts (Impact 2002+) for the production of 1MJ biodiesel (methylester only) in function to conversion rate crude Jatropha oil in methylester (with the associated avoided impact of glycerin) (After coupling of process simulator and LCA)

impacts évit	allocation	UF										
oui	100%	MJ de biodiesel										
Absolus	Taux de conv	97%	92%	87%	82%	77%	72%	67%	62%	57%	52%	50%
Non-renewable energy	MJ primary/FU	16,1708851	17,0096748	17,9453497	18,9956755	20,1830421	21,5360767	23,0919812	24,9000046	27,0267692	29,5646434	30,722672
Global warming	kg CO2/FU	0,73346889	0,77117479	0,813239	0,86046083	0,9138476	0,9746873	1,04465363	1,12596234	1,22161076	1,33575452	1,38784001
Respiratory inorganics	kg ethylene/FU	0,0007708	0,00081234	0,00085867	0,00091065	0,0009694	0,00103632	0,00111325	0,00120261	0,0013077	0,00143306	0,00149026
Terrestrial ecotoxicity	kg TEG soil/FU	6,80321788	7,16886739	7,57662131	8,03419367	8,55130609	9,14038839	9,81759336	10,6043047	11,5294495	12,6331339	13,1366557
Non-Carcinogens	kg C2H3Cl/FU	0,00626949	0,00660878	0,00698712	0,00741166	0,00789141	0,00843789	0,00906609	0,00979583	0,01065392	0,01167756	0,01214455
Carcinogens	kg C2H3Cl/FU	0,00638998	0,00672575	0,00710026	0,00752061	0,00799574	0,00853709	0,00915954	0,00988277	0,0107334	0,01174836	0,01221144
Terrestrial acidification/nutrification	kg SO2/FU	0,02523054	0,02658873	0,02810328	0,02980285	0,03172354	0,0339115	0,03642672	0,0393486	0,04278458	0,04688358	0,04875359

**Table 45** Relative difference between the results of impacts before and after coupling

	Conversion rate	97%										
Non-renewable energy	MJ primary/FU	27,2%										
Global warming	kg CO2/FU	23,4%										
Respiratory inorganics	kg ethylene/FU	4,6%										
Terrestrial ecotoxicity	kg TEG soil/FU	1,6%										
Non-Carcinogens	kg C2H3Cl/FU	33,1%										
Carcinogens	kg C2H3Cl/FU	19,1%										
Terrestrial acidification/nutrification	kg SO2/FU	5,1%										

Table 46 Relative difference between the results of impacts with or without taking into account the associated impacts of glycerin

Ecart relatif	0,97	0,92	0,87	0,82	0,77	0,72	0,67	0,62	0,57	0,52	0,5
Non-renewa	3,39E-03	3,40E-03	3,40E-03	3,41E-03	3,42E-03	3,43E-03	3,44E-03	3,44E-03	3,45E-03	3,46E-03	3,46E-03
Global warm	2,13E-03	2,13E-03	2,14E-03	2,14E-03	2,15E-03	2,16E-03	2,16E-03	2,17E-03	2,17E-03	2,18E-03	2,18E-03
Respiratory i	1,02E-03	1,02E-03	1,02E-03	1,02E-03	1,02E-03	1,02E-03	1,02E-03	1,02E-03	1,02E-03	1,02E-03	1,02E-03
Terrestrial ec	2,81E-03	2,82E-03	2,82E-03	2,82E-03	2,82E-03	2,82E-03	2,82E-03	2,83E-03	2,83E-03	2,83E-03	2,83E-03
Non-Carcino	5,75E-03	5,75E-03	5,75E-03	5,75E-03	5,75E-03	5,75E-03	5,76E-03	5,76E-03	5,76E-03	5,76E-03	5,76E-03
Carcinogens	3,24E-03	3,25E-03	3,25E-03	3,26E-03	3,26E-03	3,27E-03	3,27E-03	3,28E-03	3,28E-03	3,29E-03	3,29E-03
Terrestrial ac	8,01E-04	8,02E-04	8,02E-04	8,03E-04	8,03E-04	8,03E-04	8,04E-04	8,04E-04	8,05E-04	8,05E-04	8,05E-04





---

CHAPTER

16

---

## 16. ACRONYMS

---

### List of the French and English abbreviations

<b>ADEME</b>	Agence de l'Environnement et de la Maîtrise de l'Energie
<b>BIS</b>	Bureau of Indians Standards
<b>BP</b>	British Petroleum
<b>BPMN</b>	Business Process Model and Notation
<b>BtL</b>	Biomass to Liquid
<b>CAPE</b>	Computer Aided Process Engineering
<b>CFC</b>	Chlorofluorocarbons
<b>CIRAD</b>	Centre for International Cooperation on Developmental Agronomic Research
<b>C<sub>TG</sub></b>	Concentration of triglyceride
<b>CV</b>	Coefficient of Variation
<b>DALY</b>	Disability Adjusted Life Years
<b>DB</b>	Data Base
<b>DQIs</b>	Data Quality Indicators
<b>EIA</b>	Environmental Impact Assessment
<b>ELCD</b>	European Reference Life Cycle Database
<b>EPA</b>	Environmental Protection Agency
<b>ERA</b>	Environmental Risk Assessment
<b>EU</b>	European Union
<b>FAO</b>	Food and Agriculture Organization
<b>FFA</b>	Free Fatty Acids
<b>FU</b>	Functional Unit
<b>GHG</b>	Greenhouse Gases
<b>GtL</b>	Gas to Liquid pathway
<b>GWP</b>	Global Warming Potential
<b>HTU</b>	Hydro Thermal Upgrading
<b>IFAD</b>	International Fund for Agricultural Development
<b>IFP</b>	Institute Français de petroleum
<b>IPCC</b>	Intergovernmental Panel on Climate Change
<b>ISO</b>	International Standard Organization
<b>JCL</b>	<i>Jatropha curcas L.</i>
<b>JME</b>	Jatropha Methyl Ester
<b>KOH</b>	Potassium Hydroxide
<b>LCA</b>	Life Cycle Assessment
<b>LCI</b>	Life Cycle Inventory
<b>LCIA</b>	Life Cycle Impact Assessment
<b>LCT</b>	Life Cycle Thinking

<b>MFA</b>	Material Flow Analysis
<b>MJ</b>	Mega Joules
<b>NEG</b>	Net Energy Gain
<b>NER</b>	Net Energy Ratio
<b>OD</b>	Ozone Layer Depletion
<b>OECD</b>	Organization For Economic Cooperation And Development
<b>PDF</b>	Potentially Disappeared Fraction
<b>PET</b>	Poly Ethylene Therephtalate
<b>PSE</b>	Process System Engineering
<b>R&amp;D</b>	Resource and Development
<b>RES</b>	Renewable Energy Sources
<b>SCM</b>	Super Critical Methanol
<b>SETAC</b>	Society of Environmental Toxicology and Chemistry
<b>SFC</b>	Solid Fat Content
<b>SimLCA</b>	Simulated Life Cycle Assessment
<b>SLE</b>	Solid-Liquid Equilibrium
<b>stCALFIITP</b>	Simulis function for calculating a liquid-liquid flash temperature and pressure
<b>stCALFlash TP</b>	Simulis function for calculating a liquid-vapor flash at given temperature and pressure
<b>SWOT</b>	Strengths Weaknesses Opportunities Threats
<b>TEG</b>	Tri-ethylene glycol
<b>UML</b>	Unified Modeling Language
<b>UN</b>	United Nation
<b>UNEP</b>	United Nations Environment Program
<b>UNFCCC</b>	United Nation Framework Convention on Climate Change

## **RÉSUMÉ**

---

La méthode de l'Analyse du Cycle de Vie (ACV) est devenue ces dernières années un outil d'aide à la décision « environnementale » pour évaluer l'impact des produits et des processus associés. La pratique de l'ACV est documentée comme un outil pour l'évaluation d'impacts, la comparaison et la prise de décisions « orientée produit ». L'exploitation d'une telle méthode pour les procédés de l'industrie bio-physico-chimique a gagné récemment en popularité. Il existe de nombreux faisceaux d'amélioration et d'expansion pour sa mise en œuvre pour l'évaluation des procédés industriels. L'étude s'attache à la production de biocarburant à partir de la plante *Jatropha curcas* L. selon une approche « attributionnelle ». Cette étude présente l'évaluation environnementale d'un agro-procédé et discute de l'opportunité de coupler les concepts, les méthodes et les outils de l'ACV et de l'IPAO (Ingénierie des Procédés Assistés par Ordinateur).

Une première partie présente l'ACV appliquée à l'agrochimie. L'état de la littérature apporte des enseignements sur les diverses études qui mettent en évidence le rôle et l'importance de l'ACV pour les produits et les différents agro-procédés. La substitution des carburants classiques par les biocarburants est considérée comme une voie potentielle de substitution aux énergies fossiles. Leur processus se doit d'être évalué au regard de l'impact environnemental et du paradigme du développement durable, en complément des critères classiques, économiques et politiques.

La deuxième partie aborde notre étude ACV de la production du biocarburant à partir de la plante *Jatropha*. Cette évaluation englobe la culture et la récolte en Afrique, l'extraction de l'huile et la phase de production de biocarburants, jusqu'à son utilisation par un moteur à explosion. À cet effet, les normes ISO 14040 et 14044 sont respectées. Basée sur une perspective « midpoint » avec les méthodes de calcul d'impacts, Impact 2002+ et CML, nous fournissons les premiers résultats de la phase d'interprétation (GES, appauvrissement des ressources, la couche d'ozone, l'eutrophisation et l'acidification). Cette étude démontre le potentiel de production de biocarburants de deuxième génération à réduire l'impact environnemental. Dans le même temps, elle révèle que l'unité de transestérification est le plus impactant. Nous identifions les limites de notre application selon une approche ACV « pure ».

Dans la troisième partie, nous discutons des bénéfices attendus du couplage de l'ACV et des méthodes de modélisation et de simulation de l'ingénierie des procédés. Nous suggérons alors une amélioration de l'approche environnementale des systèmes de production. Nous fournissons un cadre de travail intégrant les différents points de vue, système, processus et procédé afin d'évaluer les performances environnementales du produit. Un outil logiciel, SimLCA, est développé sur la base de l'environnement Excel et est validé par l'utilisation de la solution ACV SimaPro et du simulateur de procédés Prosim Plus. SimLCA permet un couplage ACV-simulation pour l'évaluation environnementale du système complet de production de biocarburant. Cette intégration multi-niveaux permet une interaction dynamique des données, paramètres et résultats de simulation. Différentes configurations et scénarios sont discutés afin d'étudier l'influence de l'unité fonctionnelle et d'un paramètre de procédé. La quatrième partie établit la conclusion générale et trace les perspectives.

### **Mots clés :**

Durabilité, procédé agro-chimique, Analyse de cycle de vie, Ingénierie des procédés, Biocarburant, Analyse environnementale par la simulation, Transestérification.

## **ABSTRACT**

---

With the rise of global warming issues due to the increase of the greenhouse gas emission and more generally with growing importance granted to sustainable development, process system engineering (PSE) has turned to think more and more environmentally. Indeed, the chemical engineer has now taken into account not only the economic criteria of the process, but also its environmental and social performances. On the other hand LCA is a method used to evaluate the potential impacts on the environment of a product, process, or activity throughout its life cycle. The research here focused on coupling of PSE domain with the environmental analysis of agricultural and chemical activities and abatement strategies for agro-processes with the help of computer aided tools and models. Among many approaches, the coupling of PSE and LCA is investigated here because it is viewed as a good instrument to evaluate the environmental performance of different unitary processes and whole process. The coupling can be of different nature depending on the focus of the study. The main objective is to define an innovative LCA based on approach for a deep integration of product, process and system perspectives. We selected a PSE embedded LCA and proposed a framework that would lead to an improved eco-analysis, eco-design and eco-decision of business processes and resulted products for researchers and engineers.

In the first place we evaluate biodiesel for environmental analysis with the help of field data, background data and impact methodologies. Through this environmental evaluation, we identify the hotspot in the whole production system. To complement the experimental data this hotspot (i.e. transesterification) is selected for further modeling and simulation. For results validation, we also implement LCA in a dedicated tool (SimaPro) and simulation in a PSE simulation tool (Prosim Plus). Finally we develop a tool (SimLCA) dedicated to the LCA by using PSE tools and methodologies. This development of SimLCA framework can serve as a step forward for determination of sustainability and eco-efficient designing.

### **Key words:**

Sustainability, Agro-chemical processes, Life Cycle Assessment, Process System Engineering, Biofuel, Simulation based environmental analysis, Transesterification

---