



**HAL**  
open science

# Primitive-stable and Bowditch actions on Gromov-hyperbolic spaces

Suzanne Schlich

► **To cite this version:**

Suzanne Schlich. Primitive-stable and Bowditch actions on Gromov-hyperbolic spaces. Geometric Topology [math.GT]. Université de Lille, 2023. English. NNT : 2023ULILB022 . tel-04416547

**HAL Id: tel-04416547**

**<https://theses.hal.science/tel-04416547>**

Submitted on 25 Jan 2024

**HAL** is a multi-disciplinary open access archive for the deposit and dissemination of scientific research documents, whether they are published or not. The documents may come from teaching and research institutions in France or abroad, or from public or private research centers.

L'archive ouverte pluridisciplinaire **HAL**, est destinée au dépôt et à la diffusion de documents scientifiques de niveau recherche, publiés ou non, émanant des établissements d'enseignement et de recherche français ou étrangers, des laboratoires publics ou privés.

Ecole doctorale : MADIS-631

## THÈSE

*Pour obtenir le grade de docteur délivré par*

**l'Université de Lille**

Spécialité doctorale : Mathématiques

Laboratoire Paul Painlevé

*Préparée et soutenue publiquement par*

**Suzanne Schlich**

le 15 septembre 2023

---

### **Primitive-stable and Bowditch actions on Gromov-hyperbolic spaces**

### **Actions de Bowditch et primitives-stables sur les espaces Gromov-hyperboliques**

---

Directeur de thèse : **François Guéritaud**

#### **Jury**

<b>M. Marc Bourdon</b>	Président du jury	Université de Lille
<b>M. Louis Funar</b>	Rapporteur	Université Grenoble Alpes
<b>M. François Guéritaud</b>	Directeur de thèse	Université de Strasbourg
<b>M. Vincent Guirardel</b>	Rapporteur	Université de Rennes 1
<b>Mme. Sara Maloni</b>	Examinatrice	University of Virginia
<b>M. Andrea Seppi</b>	Examineur	Université Grenoble Alpes



# Abstract

In this thesis, we study some actions of the free group of rank two and of the fundamental group of the four-punctured sphere (which is isomorphic to the free group of rank three) on Gromov-hyperbolic spaces. The aim is to investigate two subsets of representations: Bowditch representations (introduced by Bowditch in 1998) and primitive-stable representations (introduced by Minsky in 2010). These two spaces, already studied in the case of representations in  $\mathrm{PSL}(2, \mathbb{C})$ , provide examples of open domains of discontinuity for the action of the mapping class group on the character variety. Recently, Lee and Xu on the one hand, and Series on the other, proved that these two classes of representations are equivalent in the case of the free group of rank two acting in  $\mathrm{PSL}(2, \mathbb{C})$ . In this thesis, we examine the more general case where the action of the group is on Gromov-hyperbolic spaces. We show the equivalence between Bowditch representations and primitive-stable representations in this new context by an independent proof, and establish it in the case of the free group of rank two and of the fundamental group of the four-punctured sphere. This leads us to carry out a combinatorial study of the primitive elements of the free group of rank two and of simple closed curves on the four-punctured sphere, and to show some redundancy properties of these elements. We use these combinatorial arguments combined with large-scale properties of hyperbolic spaces to show the equivalence. As a consequence, we obtain the openness of the set of Bowditch representations in this context.



# Résumé

Dans cette thèse, on s'intéresse à certaines actions du groupe libre de rang deux ainsi que du groupe fondamental de la sphère à quatre trous (isomorphe au groupe libre de rang trois) sur les espaces Gromov hyperboliques. L'objectif est d'étudier deux sous-ensembles de représentations : les représentations de Bowditch (introduites par Bowditch en 1998) ainsi que les représentations primitives-stables (introduites par Minsky en 2010). Ces deux espaces, déjà étudiés dans le cas de représentations à valeurs dans  $\mathrm{PSL}(2, \mathbb{C})$ , fournissent des exemples d'ouverts de pro-pre-discontinuité pour l'action du groupe modulaire sur la variété des caractères. Récemment, Lee et Xu d'une part, et Series d'autre part, ont montré que ces deux classes de représentations sont équivalentes dans le cas du groupe libre de rang deux agissant sur l'espace hyperbolique usuel de dimension trois. On s'intéresse dans cette thèse au cas plus général où l'action a lieu sur des espaces hyperboliques au sens de Gromov. On démontre l'équivalence entre les représentations de Bowditch et les représentations primitive-stable dans ce nouveau contexte par une preuve indépendante, et on l'établit dans le cas du groupe libre de rang deux et du groupe fondamental de la sphère à quatre trous. Cela nous conduit à mener une étude combinatoire des éléments primitifs du groupe libre de rang deux ainsi que des courbes simples sur la sphère à quatre trous et à montrer des propriétés de redondances de ces éléments. On utilise ces arguments combinatoires combinés avec des propriétés de géométrie hyperbolique grossière pour montrer l'équivalence désirée. Cela établit en conséquence l'ouverture de l'ensemble des représentations de Bowditch dans ce contexte.



# Remerciements

J'ai découvert durant mes années de thèse à quel point les mathématiques sont une aventure humaine et combien les partager, de quelque manière que ce soit, est une source de joie qui remplit de sens cette activité. Aussi j'aimerais remercier les personnes qui, de près ou de loin, par leur aide et leur soutien, ont pris part à ce chemin.

Mes premiers remerciements vont à mon directeur de thèse, François Guéritaud, envers qui je me sens infiniment redevable de tout qu'il m'aura apporté durant cette thèse. Merci d'avoir pris le temps de me faire découvrir autant de mathématiques passionnantes (avec de si beaux dessins !), et d'avoir su me guider avec tant de patience et de bienveillance tout au long de ce parcours. Je te suis très reconnaissante de ta disponibilité impressionnante, de ta gentillesse et de ton humanité sans lesquelles ce travail n'aurait sans aucun doute pas pu aboutir.

Je souhaiterais exprimer ma profonde gratitude envers Louis Funar et Vincent Guirardel, pour avoir accepté la tâche de rapporteurs. Je les remercie pour le temps qu'ils m'ont accordé par leurs relectures attentives et leurs précieux commentaires. Je remercie également Andrea Seppi, Marc Bourdon et Sara Maloni, qui se rendent disponibles et me font l'honneur de siéger dans mon jury.

Cette thèse fut jalonnée de conférences et de rencontres, aussi je remercie tous les organisateurs et organisatrices des événements scientifiques auxquels j'ai eu la chance de participer. Plus particulièrement, je suis très reconnaissante envers les chercheurs qui m'ont invitée à donner des exposés dans des conférences, séminaires ou pour des visites dans leurs instituts : Andrea Seppi, Jeremy Toulisse, Nicolas Tholozan, Thierry Coulbois, Olga Paris-Romaskevich, Christian El Emam, Georgios Kydonakis, Pierre Py, Olivier Guichard, Feng Zhu et Konstantinos Tsouvalas. J'aimerais remercier tout particulièrement Andrea Seppi et Jeremy Toulisse pour l'organisation des Workshops « jeunes chercheurs » à la fin des étés 2021 et 2022, qui furent pour moi une très grande source d'enrichissement.

Au hasard des couloirs et des rencontres, d'autres ont pris le temps de s'arrêter, discuter et ont su me prodiguer des conseils bienvenus. Ceux-ci sont précieux alors que je fais mes premiers pas dans le monde de la recherche mathématique ; ainsi je remercie Thomas Delzant, Fanny Kassel, François Labourie, Hugo Parlier et Jean-Marc Schlenker, parmi d'autres.

Ce fut un plaisir certain de rencontrer de jeunes chercheurs aux aspirations mathématiques très proches des miennes. Je remercie vivement pour les discussions stimulantes et les séances de travail partagées Christopher-Lloyd Simon, Yohann Bouilly, Tianqi Wang, Nathaniel Sagman, Ulysse Remfort et Balthazar Fléchelles.



Je voudrais remercier les membres du laboratoire Paul Painlevé à l'Université de Lille et notamment celles et ceux de l'équipe Géométrie-Dynamique pour leur accueil chaleureux lors de mon court passage parmi eux. Je tiens à adresser mes remerciements sincères à Patrick Popescu-Pampu pour son écoute attentive lors des comités de suivi et l'aide qu'il m'aura apporté. Un grand merci également à ma grande sœur de thèse Pallavi Panda qui m'a accueillie dès les premiers jours et dont j'ai découvert peu à peu le courage remarquable et les immenses qualités humaines.

Ma deuxième année de thèse fut marquée (outre une pandémie...) par un changement de ville et d'environnement : j'ai rejoint le laboratoire IRMA à l'Université de Strasbourg. Michaël Gutnic fut mon premier contact avec cet établissement et je lui suis particulièrement reconnaissante tant je n'oublie pas son soutien sans faille lors des innombrables heures passées à essayer de régler les impossibles et absurdes difficultés administratives liées à ce changement. Qu'importe la paperasse, j'ai grandement bénéficié du très bon cadre de travail du laboratoire et de l'UFR... et ce malgré les travaux parfois intempestifs ! Merci à l'ensemble des membres et personnels du laboratoire, je garderai un excellent souvenir de mes années à Strasbourg.

L'ambiance agréable et stimulante qui règne ici tient sans aucun doute beaucoup à sa joyeuse bande de (post-)doctorant-e-s ! Merci d'avoir rempli de bonne humeur ce quotidien partagé avec vous - même si je ne me suis toujours pas faite à votre heure de déjeuner honteusement prématurée. Merci à Roméo, Basile, Romane, Nico, grâce à vous j'ai enfin appris la coinche et la belote ! Merci à toutes celles et tous ceux qui ont été là pour des cafés et des discussions au tableau noir, au RA ou au bar : Adam, Clarence, Briec, Marianne, Clément, Paul, Florian, Mickaël, Victor, Victoria, Antoine, Ludovic, Léopold, Robin, Colin, Thomas, Thomas, Tom, Romain, Céline, Alex, Jean-Pierre... et Thibault, le plus constant des co-bureaux. Bien sûr je n'oublie pas Raoul et Rym, leur amitié m'est chère et je n'oublierai pas les toits strasbourgeois en leur compagnie. J'adresse aussi toute ma gratitude à Valdo et Archia pour leur soutien en des moments cruciaux.

Je ne peux m'empêcher d'avoir aussi une pensée toute particulière pour les professeurs qui - aux prémices de l'aventure ! - m'ont profondément marquée par la passion qu'ils ont réussi à transmettre. Ils sont nombreux, aussi je citerai ceux qui, en plus de leur exemplaire pédagogie, m'ont ouvert la porte de leur bureau à la veille de se jeter à l'eau : Julien Marché, Alexandru Oancea, Anthonin Guilloux et Maxime Wolff.

Il m'est difficile d'imaginer comment j'aurais pu mener à bien ce périple sans la présence constante et affectueuse de mes proches et ce, malgré la distance géographique qui bien trop souvent nous sépare. Je suis émerveillée par le soutien indéfectible du desk qui m'accompagne pratiquement quotidiennement depuis plus de huit ans maintenant : Marge, Candy et Stophe, je vous dois tant. Je me sens extrêmement chanceuse de compter parmi mes ami-e-s des personnes que j'estime profondément et qui m'inspirent : Lucie, Suzanne, Manon, Soukayna, Blandine, Honorine, Marie, Bernie, Natasha, Clairette, Vali... merci pour votre présence à mes côtés. En particulier, merci à vous amies thésardes en sciences humaines pour les inlassables et foisonnantes discussions à comparer avec incrédulité les mœurs et usages ô combien dissemblables de nos disciplines respectives ! Je me dois aussi de remercier mes colocs qui ont partagé un bout de quotidien, en particulier Alban, pour sa curiosité, et Baptiste, pour son écoute. Merci également pour tous les

bons moments passés avec les copaines de la perm des boucherXs, et dans les différents chœurs et ensembles vocaux au sein desquels j'ai eu la chance de chanter à Lille, Strasbourg, Paris et même Orange ; ce fut autant de respirations nécessaires pour garder le rythme et un certain équilibre essentiel. Mes remerciements pour Clara vont bien au-delà de cette thèse : ce que tu m'apportes dépasse tout ce que je savais possible de recevoir.

À la toute fin de ces remerciements viennent celles et ceux qui furent là depuis le tout début, et avant même le début. Je remercie du plus profond du cœur ma famille pour le cadre solide et fécond dont elle m'a entourée depuis toujours, et pour son soutien inconditionnel.



# Contents

<b>Remerciements</b>	<b>7</b>
<b>1 Introduction</b>	<b>13</b>
1.1 Context and motivation - open domains of discontinuity . . . . .	13
1.2 Bowditch representations . . . . .	14
1.3 Primitive-stable representations . . . . .	16
1.4 Equivalence . . . . .	17
1.5 The case of the four-punctured sphere . . . . .	18
1.6 Outline of the thesis and strategy of the proof . . . . .	19
<b>2 Some properties on <math>\delta</math>-hyperbolic spaces</b>	<b>23</b>
2.1 Length of a path in a $\delta$ -hyperbolic space . . . . .	23
2.2 Isometries, stable length and local-global Lemma . . . . .	34
<b>3 Bowditch representations and primitive-stable representations</b>	<b>37</b>
3.1 The inclusion $\mathcal{PS}(\Gamma, X) \subset \mathcal{BQ}(\Gamma, X)$ . . . . .	37
3.2 Openness of the set of primitive-stable representations . . . . .	38
<b>I The free group of rank two</b>	<b>41</b>
<b>4 Structure of primitive elements in the free group of rank two</b>	<b>45</b>
4.1 Constructing primitive elements . . . . .	45
4.2 Some useful lemmas . . . . .	48
<b>5 Local uniform quasi-geodesicity</b>	<b>57</b>
5.1 A first example of a uniform quasi-geodesicity setting . . . . .	57
5.2 Some properties of Bowditch representations of $\mathbb{F}_2$ . . . . .	60
<b>6 From Bowditch's hypothesis for <math>\mathbb{F}_2</math> to uniform tubular neighborhoods</b>	<b>63</b>
6.1 Continued fraction expansion of $\gamma_n$ . . . . .	65
6.2 Consequence : uniform bound on the lengths $l_i(\gamma_n)$ . . . . .	66
6.3 Excursions for real maps . . . . .	66
6.4 Excursions of the orbit map . . . . .	68

6.5	Quasi-loops . . . . .	70
6.6	Induction step . . . . .	72
6.7	Final contradiction and conclusion . . . . .	78
<b>7</b>	<b>From uniform tubular neighborhoods and Bowditch's hypothesis for <math>\mathbb{F}_2</math> to primitive-stability</b>	<b>81</b>
<b>II</b>	<b>The four-punctured sphere</b>	<b>85</b>
<b>8</b>	<b>Structure of simple closed curves on the four-punctured sphere</b>	<b>89</b>
8.1	The four-punctured sphere . . . . .	89
8.2	Simple closed curves on the four-punctured sphere . . . . .	90
8.3	Constructing simple closed curves . . . . .	97
8.4	Some generalities about lattices in $\mathbb{R}^2$ . . . . .	101
8.4.1	Rectangles adapted to a basis of a lattice and tiling of $\mathbb{R}^2$ . . . . .	101
8.4.2	Segments at height $h$ in the rectangles $S(x, u, v)$ and $R(x, u, v)$ . . . . .	111
8.5	A few reminders about <i>Farey neighbours</i> . . . . .	114
8.6	Magic-lengths Proposition . . . . .	116
8.6.1	A tiling of $\mathbb{R}^2$ . . . . .	117
8.6.2	Reading the word $\gamma$ and its subwords . . . . .	119
8.6.3	Subwords associated to a square . . . . .	120
8.6.4	Proof of Proposition 8.16 (magic-lengths) . . . . .	130
<b>9</b>	<b>Local uniform quasi-geodesicity</b>	<b>137</b>
9.1	A first example of a uniform quasi-geodesicity setting . . . . .	137
9.2	Properties on Bowditch representations of $\pi_1(S_{0,4})$ . . . . .	140
<b>10</b>	<b>From Bowditch's hypothesis for <math>\pi_1(S_{0,4})</math> to uniform tubular neighborhoods</b>	<b>145</b>
10.1	Continued fraction expansion of $\gamma_n$ . . . . .	146
10.2	Consequence : uniform bound on the lengths $l_i(\gamma_n)$ . . . . .	147
10.3	Excursions of the orbit map . . . . .	147
10.4	Quasi-loops . . . . .	148
10.5	Induction step . . . . .	148
10.6	Final contradiction and conclusion . . . . .	152
<b>11</b>	<b>From uniform tubular neighborhoods and Bowditch's hypothesis for <math>\pi_1(S_{0,4})</math> to simple-stability</b>	<b>153</b>
11.1	A few complements on continuous maps . . . . .	153
11.2	End of the proof . . . . .	154
	<b>Bibliography</b>	<b>162</b>

# Chapter 1

## Introduction

### 1.1 Context and motivation - open domains of discontinuity

In the general setting of a finitely generated group  $\Gamma$  and a topological group  $G$ , we consider the space  $\text{Hom}(\Gamma, G)$  of representations from  $\Gamma$  to  $G$  endowed with the compact-open topology, which is, since  $\Gamma$  is finitely generated, the same as the topology of pointwise convergence. This space, by far too big from a geometric point of view, admits a quotient by the action of  $G$  by conjugation which is called the character variety (in fact we make this quotient Hausdorff by considering its Hausdorffization, that is the largest Hausdorff quotient of  $\text{Hom}(\Gamma, G)/G$  ; in particular orbits whose closures intersect are identified). This space is denoted  $\chi(\Gamma, G) = \text{Hom}(\Gamma, G)//G$ . Note that in the literature,  $G$  is always taken to be a Lie group, which endows the character variety with the structure of an algebraic variety and justifies the terminology. In this thesis, we will be interested in some representations with value in  $G = \text{Isom}(X)$ , where the space  $X$  will be a  $\delta$ -hyperbolic space (geodesic and proper), which need not be a Lie group in general. However, the precise structure of  $\chi(\Gamma, G)$  does not matter for this work and, in many interesting cases of application,  $G$  will be a (real rank one) Lie group :  $\text{SO}_0(n, 1), \text{SU}(n, 1), \text{Sp}(n, 1)$  and  $\text{F}_{4(-20)}$  which are respectively the isometry group of the real hyperbolic  $n$ -space, the complex hyperbolic  $n$ -space, the quaternionic hyperbolic  $n$ -space and the hyperbolic plane over the Cayley numbers (for details on the classification of real Lie groups, see [Kna96]).

Let  $\text{Out}(\Gamma) = \text{Aut}(\Gamma)/\text{Inn}(\Gamma)$  be the outer automorphism group of  $\Gamma$ , that is the quotient of the automorphism group of  $\Gamma$  by the inner automorphisms. There is a natural action of  $\text{Out}(\Gamma)$  on the character variety by precomposition :

$$\begin{aligned} \text{Out}(\Gamma) \times \chi(\Gamma, G) &\longrightarrow \chi(\Gamma, G) \\ ([\phi], [\rho]) &\longmapsto [\phi].[\rho] = [\rho \circ \phi^{-1}] \end{aligned}$$

Note that even if the element  $\rho \circ \phi^{-1}$  is not well-defined since  $\phi$  is only defined up to inner automorphisms, its class  $[\rho \circ \phi^{-1}]$  is well-defined. Understanding the dynamics of this action and finding subspaces of the character variety on which the group  $\text{Out}(\Gamma)$  acts geometrically "nicely" is a central issue. Indeed, the character variety appears naturally to encode some geometric structures.

**Example 1.1** (Teichmüller space,  $\Gamma = \pi_1(S), G = \text{PSL}(2, \mathbb{R})$ ). The starting example is the Teichmüller space  $\mathcal{T}(S)$ . Let  $S$  be a closed oriented surface of negative Euler characteristic and  $\pi_1(S)$

its fundamental group. The space  $\mathcal{T}(S)$  is defined as the space of hyperbolic metrics up to isotopy on  $S$ . It is a well-known fact that the Teichmüller space identifies as a connected component of the character variety  $\chi(\pi_1(S), \mathrm{PSL}(2, \mathbb{R}))$  (see Goldman [Gol88], Farb-Margalit [FM12]). The mapping class group  $\mathrm{MCG}(S)$  of the surface  $S$ , which is the group of isotopy classes of orientation-preserving homeomorphisms of  $S$ , may be identified with an index two subgroup of  $\mathrm{Out}(\pi_1(S))$  and acts on the Teichmüller space. Recall that the action of a group  $\mathcal{G}$  on a topological space  $\mathcal{X}$  is said *properly discontinuous* if, for each compact  $K$  in  $\mathcal{X}$ , the set  $\{g \in \mathcal{G} \mid (gK) \cap K \neq \emptyset\}$  is finite. The dynamics of the action of the mapping class group on the Teichmüller space is given by the Fricke's Theorem :

**Theorem 1.1** (Fricke). *The action of  $\mathrm{MCG}(S)$  on  $\mathcal{T}(S)$  is properly discontinuous.*

**Example 1.2** (Convex-cocompact representations,  $\Gamma$  hyperbolic,  $G = \mathrm{SO}_0(n, 1)$ ). Another central example of an open domain of discontinuity of the character variety is the set of convex-cocompact representations : let  $\Gamma$  be a hyperbolic group and  $G = \mathrm{SO}_0(n, 1)$  be the isometry group of the hyperbolic  $n$ -space  $\mathbb{H}^n$ , define  $\mathrm{CC}(\Gamma, G)$  to be the subset of the character variety consisting of representations which preserve a non-empty convex subspace of  $\mathbb{H}^n$  on which the action is proper and cocompact. This is equivalent to asking that the orbit map is a quasi-isometric embedding. In particular  $\mathrm{CC}(\Gamma, G)$  consists only of discrete representations. The  $G$ -orbits of such representations in  $\mathrm{Hom}(\Gamma, G)$  under conjugation are closed. It can be shown that  $\mathrm{CC}(\Gamma, G)$  is open and that the outer automorphism group  $\mathrm{Out}(\Gamma)$  acts properly discontinuously on it. Hence it is natural to ask if this domain of discontinuity is maximal for the action of  $\mathrm{Out}(\Gamma)$ . Are there other domains of discontinuity ? Could they contain non-discrete representations ?

## 1.2 Bowditch representations

Let  $(X, d)$  be a  $\delta$ -hyperbolic space, geodesic and proper and  $\mathbb{F}_2$  be the free group of rank two. We fix  $\{a, b\}$  a free generating set for  $\mathbb{F}_2$ . In this thesis, we will in particular study some representations of  $\mathbb{F}_2$  into the isometry group of  $X$ .

We denote by  $\|\gamma\|$  the cyclically reduced word length of an element  $\gamma$  in  $\mathbb{F}_2$  relatively to the set of two generators  $\{a, b\}$ . Recall that the choice of the specific set of generators has no real impact on the word length insofar as another choice of two generators would give a bi-Lipschitz equivalent word length. When given an isometry  $A$  of the metric space  $X$ , we can consider its *displacement length*, that is the non-negative real  $l(A) := \inf_{x \in X} d(Ax, x)$ . For a representation  $\rho : \mathbb{F}_2 \rightarrow \mathrm{Isom}(X)$ , we will denote by  $l_\rho(\gamma) := l(\rho(\gamma))$  the displacement length of  $\rho(\gamma)$ , for  $\gamma \in \mathbb{F}_2$ . We can always compare, for any representation, the displacement length and the word length in the following way :

$$\forall \gamma \in \mathbb{F}_2, \quad l_\rho(\gamma) \leq C' \|\gamma\|.$$

Here,  $C'$  is a constant that can be chosen to be the maximum  $C' := \max\{d(\rho(a)o, o), d(\rho(b)o, o)\}$  with  $o$  being any basepoint of  $X$ . Indeed, for  $\gamma$  cyclically reduced,  $l_\rho(\gamma) \leq d(\rho(\gamma)o, o) \leq C' \|\gamma\|$  by the triangle inequality.

One might ask about the other inequality, that is, does there exist two constants  $C$  and  $D$ , such that for any element  $\gamma \in \mathbb{F}_2$ , we have :

$$\frac{1}{C}\|\gamma\| - D \leq l_\rho(\gamma) \quad ? \quad (1.1)$$

Of course this is not true in general, and it gives rise to the notion of convex-cocompact representations already mentioned in the example 1.2 above.

In the free group  $\mathbb{F}_2$ , we say that an element  $\gamma \in \mathbb{F}_2$  is *primitive* if it is part of a free basis of  $\mathbb{F}_2$ . We denote by  $\mathcal{P}(\mathbb{F}_2)$  the set of primitive elements in  $\mathbb{F}_2$ .

Following the work of Bowditch ([Bow98]), a broader class of representations can be obtained when considering this last inequality (1.1) only for primitive elements in  $\mathbb{F}_2$ , and this leads to the notion of what we call a Bowditch representation.

**Definition 1.1** (Bowditch representations,  $\Gamma = \mathbb{F}_2$ ). Let  $\rho : \mathbb{F}_2 \rightarrow \text{Isom}(X)$  be a representation and  $C \geq 1, D \geq 0$  two constants. We say that  $\rho$  is a *Bowditch representation of constants*  $(C, D)$  if :

$$\forall \gamma \in \mathcal{P}(\mathbb{F}_2), \quad \frac{1}{C}\|\gamma\| - D \leq l_\rho(\gamma) \quad (1.2)$$

We say that  $\rho$  is a *Bowditch representation* if there exist two constants  $C \geq 1$  and  $D \geq 0$  such that  $\rho$  is a Bowditch representation of constants  $(C, D)$ .

Denote by  $\mathcal{BQ}(\mathbb{F}_2, X)$  the set of Bowditch representations from  $\mathbb{F}_2$  to  $\text{Isom}(X)$ .

The original definition by Bowditch ([Bow98]) was given for representations of  $\mathbb{F}_2$  into  $\text{PSL}(2, \mathbb{C})$ . He defined these representations using the traces in  $\text{PSL}(2, \mathbb{C})$  of the image of primitive elements, as follows :

1.  $\text{Tr}(\rho([a, b])) = -2$ , where  $[a, b]$  denotes the commutator of two generators  $a$  and  $b$  of  $\mathbb{F}_2$ .
2. For all  $\gamma \in \mathcal{P}(\mathbb{F}_2)$ ,  $\text{Tr}(\rho(\gamma)) \notin [-2, 2]$
3. The set  $\{\gamma \in \mathcal{P}(\mathbb{F}_2) : |\text{Tr}(\rho(\gamma))| \leq 2\}$  is finite.

Bowditch defines  $\mathcal{BQ}$  to be the space of representations of  $\mathbb{F}_2$  into  $\text{PSL}(2, \mathbb{C})$  (modulo conjugation) satisfying the three previous conditions. Bowditch shows ([Bow98], Theorem 3.16), that  $\mathcal{BQ}$  is open in the character variety  $\chi(\mathbb{F}_2, \text{PSL}(2, \mathbb{C}))$  and that the outer automorphism group of  $\mathbb{F}_2$ ,  $\text{Out}(\mathbb{F}_2)$ , acts properly discontinuously on  $\mathcal{BQ}$ . Hence  $\mathcal{BQ}$  produces an open domain of discontinuity for the action of  $\text{Out}(\mathbb{F}_2)$  on  $\chi(\mathbb{F}_2, \text{PSL}(2, \mathbb{C}))$ . In addition, Bowditch shows that ([Bow98], Theorem 2) :

$$\text{for all } \rho \in \mathcal{BQ}, \quad \text{there exists a constant } C > 0 \text{ such that for all } \gamma \in \mathcal{P}(\mathbb{F}_2), \quad \frac{1}{C}\|\gamma\| \leq l_\rho(\gamma). \quad (1.3)$$

Note that in this inequality,  $l_\rho(\gamma)$  makes sense because  $\rho(\gamma)$  is an isometry of the usual hyperbolic space of dimension 3 (recall that  $\text{PSL}(2, \mathbb{C}) = \text{Isom}^+(\mathbb{H}^3)$ ).



The work of Bowditch was later generalized by Tan, Wong and Zhang in [TWZ08] for representations satisfying only conditions 2. and 3. (that is when  $\text{Tr}(\rho([a, b])) = \tau$ , for any  $\tau \in \mathbb{C}$ ). They showed, as in the case of Bowditch where 1. also holds ( $\text{Tr}(\rho([a, b])) = -2$ ), that these representations form an open subspace of the character variety on which the outer automorphism group acts properly discontinuously. They also showed that the inequality (1.3) holds. It is easy to check that the converse is also true : when a representation satisfy (1.3), it automatically satisfy conditions 2. and 3. Thus, the inequality (1.3), which does not make use anymore of the traces of elements in  $\text{PSL}(2, \mathbb{C})$ , can thus be generalised to  $\text{Isom}(X)$  as done in definition 1.1. Note that the additive constant in definition 1.1 plays no major role.

### 1.3 Primitive-stable representations

Consider  $\mathcal{C}$  the Cayley graph of the free group of rank two  $\mathbb{F}_2$  with respect to the free generating set  $\{a, b\}$  chosen in previous section. This graph comes equipped with the word metric, that we denote again  $d$  (in context, there should be no ambiguity with the metric  $d$  of the metric space  $X$ ) and which satisfies :  $d(u, v) = |u^{-1}v|$ , where  $|\cdot|$  is the word length. We will sometimes refer to the vertices of  $\mathcal{C}$  as the integer points of  $\mathcal{C}$ . For  $\gamma \in \mathbb{F}_2$ , we denote by  $L_\gamma$  the axis of  $\gamma$  in the Cayley graph  $\mathcal{C}$ . Note that when  $\gamma$  is cyclically reduced,  $L_\gamma = \bigcup_{n \in \mathbb{Z}} [\gamma^n, \gamma^{n+1}]$ . We will refer to the geodesics  $L_\gamma$  with  $\gamma \in \mathcal{P}(\mathbb{F}_2)$  as *primitive-leaves*.

Fix  $o$  a basepoint in  $X$ . For every representation  $\rho$  of  $\mathbb{F}_2$  in  $\text{Isom}(X)$  we define the orbit map  $\tau_\rho$  of  $\rho$  to be the unique  $\rho$ -equivariant map from the Cayley graph  $\mathcal{C}$  of  $\mathbb{F}_2$  into  $X$  such that  $\tau_\rho(1) = o$  and each edge of  $\mathcal{C}$  is mapped to a geodesic segment in  $X$ . Thus we have that  $\tau_\rho$  is continuous and that for any vertex  $g \in \mathbb{F}_2$ ,  $\tau_\rho(g) = \rho(g)o$ . Moreover,  $\tau_\rho$  is Lipschitz, with Lipschitz constant  $C'$ , where  $C'$  can be chosen to be the maximum  $C' := \max\{d(\rho(a)o, o), d(\rho(b)o, o)\}$  (with  $\{a, b\}$  the free generating set for  $\mathbb{F}_2$  used to define the Cayley graph  $\mathcal{C}$ ). This is, as for the inequality (1.2), a consequence of the triangle inequality.

Before stating the definition of primitive-stable representations, we recall the definition of a quasi-isometric embedding :

**Definition 1.2.** Let  $(\mathcal{X}, d_{\mathcal{X}})$  and  $(\mathcal{Y}, d_{\mathcal{Y}})$  be two metric spaces and  $C > 0, D \geq 0$  be two constants. We say that a map  $f : \mathcal{X} \rightarrow \mathcal{Y}$  is a  $(C, D)$ -*quasi-isometric embedding* if for all points  $x$  and  $x'$  in  $\mathcal{X}$ , we have :

$$\frac{1}{C}d_{\mathcal{X}}(x, x') - D \leq d_{\mathcal{Y}}(f(x), f(x')) \leq Cd_{\mathcal{X}}(x, x') + D \quad (1.4)$$

We now give the definition of a primitive-stable representation, as introduced by Minsky in [Min13].

**Definition 1.3** (Primitive-stable representations,  $\Gamma = \mathbb{F}_2$ ). Let  $\rho : \mathbb{F}_2 \rightarrow \text{Isom}(X)$  be a representation. We say that  $\rho$  is *primitive-stable* if there exist two constants  $C \geq 1$  and  $D \geq 0$  such that for any primitive element  $\gamma \in \mathbb{F}_2$ , the orbit map  $\tau_\rho$  restricted to  $L_\gamma$  is a  $(C, D)$ -quasi-isometric embedding.

Minsky defined primitive-stability for representations with values in  $\mathrm{PSL}(2, \mathbb{C}) = \mathrm{Isom}^+(\mathbb{H}^3)$ , but his definition generalizes directly to the more general  $\delta$ -hyperbolic case.

Note that since, as mentioned above, the orbit map  $\tau_\rho$  is always Lipschitz, showing that the orbit map is a quasi-isometric embedding (either on the Cayley graph or on primitive-leaves) reduced to showing the left inequality of (1.4) :  $\frac{1}{C}d(x, x') - D \leq d(\tau_\rho(x), \tau_\rho(x'))$ . Also notice that the primitive-stability condition only need to be verified on cyclically reduced primitive elements.

Remark that when primitive elements are sent to hyperbolic isometries via the representation, the orbit map restricted to any primitive leave  $L_\gamma$  is always a quasi-isometric embedding. However, the constants may depend on the primitive element  $\gamma$ . Hence Minsky's definition of primitive-stability is really about saying that all primitive-leaves are mapped to *uniform* quasi-geodesics in  $X$ .

Minsky proved, in [Min13], that the set of primitive-stable representations is open in the character variety  $\chi(\mathbb{F}_2, \mathrm{PSL}(2, \mathbb{C}))$ , that it is invariant under the action of the outer automorphism group  $\mathrm{Out}(\mathbb{F}_2)$  and that this action is properly discontinuous. Hence primitive-stable representations provide an open domain of discontinuity for the action of  $\mathrm{Out}(\mathbb{F}_2)$  on the character variety  $\chi(\mathbb{F}_2, \mathrm{PSL}(2, \mathbb{C}))$ . Moreover, Minsky proved that the set of primitive-stable representations strictly contains the set of discrete and faithful convex-cocompact representations, which is the interior of the set of discrete representation. Thus there exist non-discrete primitive-stable representations. Denote by  $\mathcal{PS}(\mathbb{F}_2, X)$  the set of primitive-stable representations from  $\mathbb{F}_2$  to  $\mathrm{Isom}(X)$ .

## 1.4 Equivalence

Lee and Xu on one hand (in [LX19]), and Series independently (in [Ser19], [Ser20]), proved that the set of Bowditch representations and primitive-stable representations of  $\mathbb{F}_2$  with values in  $\mathrm{PSL}(2, \mathbb{C})$  are equal.

The aim of this thesis is to work on a generalisation of this result to the case of representations in the isometry group of a  $\delta$ -hyperbolic space. Our proof and techniques are independent of those of Lee-Xu and Series for the case  $\mathrm{PSL}(2, \mathbb{C})$ .

**Theorem 1.2.** *Let  $X$  be a  $\delta$ -hyperbolic space, geodesic and proper.*

*Then the set of Bowditch representations and primitive-stable representations of  $\mathbb{F}_2$  are equal.*

$$\mathcal{BQ}(\mathbb{F}_2, X) = \mathcal{PS}(\mathbb{F}_2, X)$$

It is not hard to prove that primitive-stable representations form an open subspace of  $\chi(\mathbb{F}_2, \mathrm{Isom}(X))$ . We give a proof of this property in section 3.2. The action of the outer automorphism group  $\mathrm{Out}(\mathbb{F}_2)$  is properly discontinuous on the set of Bowditch representation  $\mathcal{BQ}(X)$  so we obtain the following corollary :

**Corollary 1.3.** *The set  $\mathcal{BQ}(\mathbb{F}_2, X)$  is an open domain of discontinuity for the action of  $\mathrm{Out}(\mathbb{F}_2)$  on  $\chi(\mathbb{F}_2, \mathrm{Isom}(X))$ .*

## 1.5 The case of the four-punctured sphere

We say that a closed curve  $\gamma$  on a surface  $S$  is *simple* if there exists a representative of  $\gamma$  in its homotopy class which has no self-intersection and which does not bound a disk or a once-punctured disk. Let us denote by  $\mathcal{S}(S)$  the set of free homotopy classes of (unoriented) simple closed curves on  $S$ . Of course the set of simple closed curves is invariant under the action of the mapping group of  $S$ .

Let us recall that the group  $\mathbb{F}_2$  is the fundamental group of the once-punctured torus  $\mathbb{T}$ . Primitive conjugacy classes in  $\mathbb{F}_2 = \pi_1(\mathbb{T})$  are in bijective correspondence with the oriented simple closed curves on the torus. The mapping class group of the torus identifies with an index two subgroup of the outer automorphism group  $\text{Out}(\mathbb{F}_2)$ . Thus this analogy between primitive elements in  $\mathbb{F}_2$  and simple closed curves on the torus suggests that we consider a natural generalisation of Bowditch representations and primitive-stable representations to fundamental groups of surfaces, possibly with boundary. Indeed, the definition of Bowditch representations given in Definition 1.1 still makes sense when replacing  $\mathbb{F}_2$  with  $\pi_1(S)$  and  $\mathcal{P}(\mathbb{F}_2)$  with  $\mathcal{S}(S)$ . In the same way, Definition 1.3 of primitive-stable representations still makes sense when replacing  $\mathbb{F}_2$  by  $\pi_1(S)$  and primitive elements by simple closed curves on  $S$ , and in this context we will call them *simple-stable* representations. For the sake of completeness, we write here the definitions of a Bowditch representation and a simple-stable representation in the context of fundamental groups of surfaces :

**Definition 1.4** (Bowditch representations,  $\Gamma = \pi_1(S)$ ). Let  $\rho : \pi_1(S) \rightarrow \text{Isom}(X)$  be a representation and  $C \geq 1, D \geq 0$  two constants. We say that  $\rho$  is a *Bowditch representation of constants*  $(C, D)$  if :

$$\forall \gamma \in \mathcal{S}(S), \quad \frac{1}{C} \|\gamma\| - D \leq l_\rho(\gamma) \quad (1.5)$$

We say that  $\rho$  is a *Bowditch representation* if there exist two constants  $C \geq 1$  and  $D \geq 0$  such that  $\rho$  is a Bowditch representation of constants  $(C, D)$ .

We denote by  $\mathcal{BQ}(\pi_1(S), X)$  the set of Bowditch representations from  $\pi_1(S)$  to  $\text{Isom}(X)$ .

**Definition 1.5** (Simple-stable representations,  $\Gamma = \pi_1(S)$ ). Let  $\rho : \pi_1(S) \rightarrow \text{Isom}(X)$  be a representation. We say that  $\rho$  is *simple-stable* if there exist two constants  $C \geq 1$  and  $D \geq 0$  such that for any simple element  $\gamma \in \mathcal{S}(S)$ , the orbit map  $\tau_\rho$  restricted to  $L_\gamma$  is a  $(C, D)$ -quasi-isometric embedding.

We denote by  $\mathcal{PS}(\pi_1(S), X)$  the set of simple-stable representations from  $\pi_1(S)$  to  $\text{Isom}(X)$ .

Thus, in a second part of the thesis we will be interested in the case where the surface  $S$  is the four-punctured sphere  $S_{0,4}$ . In this new setting, we prove the equivalence between Bowditch and simple-stable representations :

**Theorem 1.4.** *Let  $X$  be a  $\delta$ -hyperbolic space, geodesic and proper.*

*Then the sets of Bowditch representations and of simple-stable representations of  $\pi_1(S_{0,4})$  are equal.*

$$\mathcal{BQ}(\pi_1(S_{0,4}), X) = \mathcal{PS}(\pi_1(S_{0,4}), X)$$

In a similar way to the case of  $\mathbb{F}_2$ , this gives the following corollary :

**Corollary 1.5.** *The set  $\mathcal{BQ}(\pi_1(S_{0,4}), X)$  is an open domain of discontinuity for the action of  $\text{MCG}(\pi_1(S_{0,4}))$  on  $\chi(\pi_1(S_{0,4}), \text{Isom}(X))$ .*

The equivalence for more general surfaces  $S_{g,n}$  of genus  $g$  with  $n$  punctures, remains open :

**Question.** *Let  $S_{g,n}$  be a surface of genus  $g$  with  $n$  punctures.*

$$\begin{aligned} \text{Is } \mathcal{BQ}(\pi_1(S_{g,n}), X) = \mathcal{PS}(\pi_1(S_{g,n}), X) ? \\ \text{Is } \mathcal{BQ}(\pi_1(S_{g,n}), X) \text{ open ?} \end{aligned}$$

Hence, theorem 1.2 and 1.4 provide a positive answer to the above question in the case where  $S_{g,n}$  is the once-punctured torus ( $g = 1, n = 1$ ) and in the case where  $S_{g,n}$  is the four-punctured sphere ( $g = 0, n = 4$ ).

*Remark 1.6.* The  $\text{SL}(2, \mathbb{C})$ -character variety of the four-punctured sphere has been studied by Maloni, Palesi and Tan (see [MPT15], see also Palesi [Pal14]). In particular, they proved that the Bowditch set  $\mathcal{BQ}(\pi_1(S_{0,4}), \mathbb{H}^3)$  is an open domain of discontinuity for the action of the mapping class group. In addition, they provide a characterization similar to the Bowditch conditions 1., 2. and 3. Maloni, Palesi and Yang also studied the  $\text{PGL}(2, \mathbb{R})$  and  $\text{SL}(2, \mathbb{C})$  character variety of the three-holed projective plane in [MPY21] and [MP20].

*Remark 1.7.* We can draw an analogy between the two Theorems 1.2 and 1.4 and a result of Delzant, Guichard, Labourie and Mozes (see [Del+11], see also a survey of Canary [Can15]) which says that for  $\Gamma$  a hyperbolic group and  $X$  a metric space, a representation  $\rho : \Gamma \rightarrow \text{Isom}(X)$  is displacing if and only if its orbit map is a quasi-isometric embedding. By displacing, the authors mean that the displacement length  $l_\rho(\gamma)$  grows linearly with the cyclically reduced word length  $|\gamma|$ . The Bowditch condition (Definition 1.1) can be seen as a restriction of the displacing condition on primitive elements (or simple closed curves), hence we could talk about *primitive-displacing* (or about *simple-displacing*) representations. Primitive-stability (or simple-stability) is a restriction of the condition of quasi-isometric embedding of the orbit map on primitive leaves (or simple leaves). Therefore Theorem 1.2 and 1.4 can be reinterpreted by saying that a representation of  $\mathbb{F}_2$  (resp. of  $\pi_1(S_{0,4})$ ) is primitive-displacing (resp. simple-displacing) if and only if its orbit map is a quasi-isometric embedding on primitive leaves (resp. simple leaves).

## 1.6 Outline of the thesis and strategy of the proof

Let us detail the plan of the thesis. Chapter 2 is dedicated to some generalities on  $\delta$ -hyperbolic spaces. In particular, in section 2.1 we establish a lower bound on the length of a path in a  $\delta$ -hyperbolic space which stays "far away" from a geodesic. The main result of this section is proposition 2.11. In section 2.2 we gather together a few results about isometries and quasi-geodesics in a  $\delta$ -hyperbolic space. Then follows a short chapter (Chapter 3) which aims to give some basic properties about Bowditch and primitive-stable (or simple-stable) representations : first, in section 3.1, the inclusion  $\mathcal{PS}(\Gamma, X) \subset \mathcal{BQ}(\Gamma, X)$  for  $\Gamma = \mathbb{F}_2$  or  $\pi_1(S_{0,4})$  which poses no difficulty (notice

that this inclusion was already proven by Minsky in [Min13]), then, in section 3.2, the openness of the set of primitive-stable (or simple-stable) representations.

We then divide the dissertation, which aims at proving theorems 1.2 and 1.4, into two parts : one on the case of the free group of rank two (Part I) and the other on the case of the fundamental group of the four-punctured sphere (Part II). Even though the general strategy of the proof is the same for theorems 1.2 and 1.4, it relies on combinatorial properties in  $\mathbb{F}_2$  and in  $\pi_1(S_{0,4})$  which are not exactly the same and which we prove in totally different ways.

Thus, chapter 4 and chapter 8 will be respectively dedicated to studying the structure of primitive words in  $\mathbb{F}_2$  and the structure simple closed curves in  $\pi_1(S_{0,4})$ . More specifically, one of the goals is to understand the *redundancy* of primitive subwords within a primitive word in  $\mathbb{F}_2$  (respectively simple subwords in a simple word in  $\pi_1(S_{0,4})$ ). Precisely, in the case of  $\mathbb{F}_2$ , in definition 4.1 and proposition 4.3, we explain how to decompose  $\gamma$  (or maybe a cyclic permutation of  $\gamma$ ) as a concatenation of primitive subwords for different scales, which will correspond to the successive steps in the continued fraction expansion of the *slope* of  $\gamma$  (for the reader unfamiliar with these notions, they are recalled in the beginning of section 4). Then, in lemma 4.6, we prove that for every primitive word  $\gamma \in \mathbb{F}_2$ , there exist some specific lengths, which we call "magic-lengths", such that each subword of  $\gamma$  of one of these lengths is "nearly" primitive, in the sense that it is so up to changing its last letter. In the case of  $\pi_1(S_{0,4})$ , we don't find "magic-lengths" such that every subwords of one of these lengths is "nearly" simple, but we find "magic-lengths" such that every subword of one of these lengths can be found (together with its inverse) in many other places in the word. This is Proposition 8.16.

Next comes Chapter 5 (in the case of  $\mathbb{F}_2$ ) and Chapter 9 (in the case of  $\pi_1(S_{0,4})$ ) which discuss two important examples of a uniform quasi-geodesicity setting which will be reused later. They also establish some useful Lemmas on Bowditch representations using some of the combinatorial descriptions of primitive elements in  $\mathbb{F}_2$  resp. simple elements in  $\pi_1(S_{0,4})$  given in the previous Chapters 4 resp. 8.

Finally we want to show, starting from a Bowditch representation, that it is primitive-stable (or simple-stable), meaning that all the geodesics  $L_\gamma$  (for  $\gamma$  primitive, or simple) are mapped by the orbit map to uniform quasi-geodesics in  $X$ . It is almost immediate to see that under the Bowditch hypothesis, the geodesic  $L_\gamma$  are mapped to quasi-geodesics, but the constants of quasi-geodesicity might depend on  $\gamma$ . The main difficulty, and first step of the proof, will be to show that these quasi-geodesics  $\tau_\rho(L_\gamma)$  stay in a uniform neighborhood of the axis of  $\rho(\gamma)$ . Namely, this means that our family of quasi-geodesics  $\tau_\rho(L_\gamma)$  satisfies a Morse lemma. After this major step in the proof, done in Chapter 6 (in the case of  $\mathbb{F}_2$ ) and in Chapter 10 (in the case of  $\pi_1(S_{0,4})$ ), there will only be a little work left in order to show the primitive-stability of the representation  $\rho$ , and this will be done in Chapter 7 (in the case of  $\mathbb{F}_2$ ) and in Chapter 11 (in the case of  $\pi_1(S_{0,4})$ ).

Let us now explain what are the key ideas of the main step of the proof, which states (proposition 6.3 and 10.1) that the quasi-geodesics  $\tau_\rho(L_\gamma)$  stay "close" to the axis of  $\rho(\gamma)$ .

We will proceed by contradiction and suppose that we can find a primitive (or simple) element  $\gamma$  such that the associated quasi-geodesic  $\tau_\rho(L_\gamma)$  does not stay close to the axis of  $\rho(\gamma)$ . Then we can find what we will call an *excursion*, that is a path extracted from the quasi-geodesic that remains "far away" from the axis of  $\rho(\gamma)$  (section 6.3 and 6.4 for  $\mathbb{F}_2$  and section 10.3 for  $\pi_1(S_{0,4})$ ). We will next define the notion of a *quasi-loop* (section 6.5 for  $\mathbb{F}_2$  and section 10.4 for  $\pi_1(S_{0,4})$ ), which will be an element  $u$  of the group such that  $\rho(u)$  does not displace the basepoint much, and prove in lemma 6.14 that every "big" excursion corresponds to a quasi-loop. This enables us to find a subword of the element  $\gamma$  which is a quasi-loop. The goal will be next to find as many disjoint quasi-loops as possible in  $\gamma$  and to do so, we will use the results of section 4 and 8. Indeed, our quasi-loop is contained in a subword of  $\gamma$  whose length is one of the "magic-lengths" defined in Proposition 4.6 (case  $\mathbb{F}_2$ ) or Proposition 8.16 (case  $\pi_1(S_{0,4})$ ), and thus this subword can be found everywhere in  $\gamma$ , therefore with this process we will find our quasi-loop many times in  $\gamma$ . This will ensure that some proportion of  $\gamma$  does not displace the basepoint much (Lemma 6.17 and Lemma 10.6). Finally, using a recursive argument on the depth of the continued fraction expansion of the slope of  $\gamma$  (in Chapter 4 and 8, we will have seen how to associate a slope to a primitive element in  $\mathbb{F}_2$  and to a simple closed curve in  $\pi_1(S_{0,4})$ ), we will be able to show that we can find an arbitrarily big proportion of the word  $\gamma$  that does not displace the basepoint much (Lemma 6.18 and Lemma 10.7), which will be in contradiction with the Bowditch hypothesis.



# Chapter 2

## Some properties on $\delta$ -hyperbolic spaces

### 2.1 Length of a path in a $\delta$ -hyperbolic space

In this section, we will be interested in some properties of length of paths in hyperbolic space. The goal is to prove the inequalities of Proposition 2.11. Part of the material of this section is drawn from or inspired by [CDP90]. Let  $X$  be a Gromov-hyperbolic space, with hyperbolic constant  $\delta$ , and suppose that  $X$  is geodesic. Denote by  $d$  the hyperbolic distance of  $X$ . We will write  $[x, y]$  for some geodesic segment with endpoints  $x$  and  $y$  in  $X$  and  $T = [x, y, z]$  for a triangle with vertices  $x, y$  and  $z$ . Recall that we say that a triangle is  $\delta$ -thin if each side of the triangle is included in the  $\delta$ -neighborhood of the other two. A metric space is  $\delta$ -hyperbolic if every triangle is  $\delta$ -thin.

This first lemma, which is a classical result of hyperbolic geometry, gives the existence of three "close" points in  $\delta$ -thin triangles.

**Lemma 2.1.** *Let  $(X, d)$  be a metric space and  $T = [x, y, z]$  a  $\delta$ -thin triangle of  $X$ . There exists  $r \in [x, y], s \in [y, z]$  and  $t \in [x, z]$  such that  $d(r, s) \leq \delta$  and  $d(r, t) \leq \delta$ . (Hence in addition  $d(s, t) \leq 2\delta$ )*

*Proof.* Consider :

$$\begin{aligned} L &= \{r \in [x, y] : \exists t \in [x, z], d(r, t) \leq \delta\} \\ R &= \{r \in [x, y] : \exists s \in [z, y], d(r, s) \leq \delta\} \end{aligned}$$

Then :

- $R$  and  $L$  are non-empty because  $x \in L$  and  $y \in R$ .
- $R$  and  $L$  are closed because  $[x, z]$  and  $[z, y]$  are compact.
- We have  $[x, y] = R \cup L$  since the triangle  $[x, y, z]$  is  $\delta$ -thin.

We deduce that  $R \cap L \neq \emptyset$ .

Indeed, if  $R \cap L = \emptyset$ , we would obtain an open cover of  $[x, y]$  with two disjoint non-empty open sets  $([x, y] \setminus L$  and  $[x, y] \setminus R)$ , which would contradict the connectedness of  $[x, y]$ .



Thus we deduce the existence of  $r \in [x, y]$ ,  $s \in [y, z]$  and  $t \in [x, z]$  such that  $d(r, s) \leq \delta$  and  $d(r, t) \leq \delta$ . □

The following lemma generalises the notion of  $\delta$ -thin triangle in  $\delta$ -hyperbolic spaces and is taken from [CDP90].

**Lemma 2.2.** *Let  $X$  be a  $\delta$ -hyperbolic geodesic space and  $Y = [x_0, x_1] \cup [x_1, x_2] \cup \dots \cup [x_{n-1}, x_n]$  a chain of  $n$  geodesic segments, with  $n \leq 2^k$ , where  $k$  is an integer such that  $k \geq 1$ . Then, for any point  $x$  in a geodesic segment  $[x_0, x_n]$ , we have  $d(x, Y) \leq k\delta$ .*

*Proof.* Let us proceed by induction on  $k \geq 1$ .

- If  $k = 1$ , that is  $n = 2$ , it is the case of a triangle. Since  $X$  is  $\delta$ -hyperbolic, then the triangles are  $\delta$ -thin, so we have the requested inequality.
- Assume that the property is true for some  $k \geq 1$  and let us consider  $n$  geodesic segments, with  $n \leq 2^{k+1}$ . After possibly artificially adding points on  $Y$ , we can assume that  $n = 2^{k+1}$ . Let  $x \in [x_0, x_n]$ . The triangle with vertices  $x_0, x_{\frac{n}{2}}$  and  $x_n$  is  $\delta$ -thin which ensures the existence of  $m \in [x_0, x_{\frac{n}{2}}] \cup [x_{\frac{n}{2}}, x_n]$  such that  $d(x, m) \leq \delta$ . Without loss of generality, suppose that  $m \in [x_0, x_{\frac{n}{2}}]$ . We have  $\frac{n}{2} \leq 2^k$  so by induction we can find a point  $m' \in [x_0, x_1] \cup \dots \cup [x_{\frac{n}{2}-1}, x_{\frac{n}{2}}]$  such that  $d(m, m') \leq k\delta$ . Thus, by the triangle inequality, we obtain :  $d(x, m') \leq d(x, m) + d(m, m') \leq \delta + k\delta = (k+1)\delta$ . □

In particular, by the lemma 2.2, if we consider a hyperbolic quadrilateral with vertices  $x, y, y_1, x_1$  (in this order), then every point of  $[x, y]$  is at a distance at most  $2\delta$  of a point of  $[x, x_1] \cup [x_1, y_1] \cup [y_1, y]$ . Thus we have the following alternative :

- $\forall z \in [x, y], d(z, [x_1, y_1]) > 2\delta$  and in this case  $\forall z \in [x, y], d(z, [x, x_1] \cup [y, y_1]) \leq 2\delta$
- $\exists z \in [x, y], d(z, [x_1, y_1]) \leq 2\delta$

Several of the following lemmas depend on this alternative. The following lemma finds three "close" points in the quadrilateral in the first case of this alternative.

**Lemma 2.3.** *Let  $X$  be a  $\delta$ -hyperbolic geodesic space, and  $x, x_1, y_1, y \in X$  (in this order) be the vertices of a hyperbolic quadrilateral of  $X$ . We further assume that for all  $z \in [x, y], d(z, [x_1, y_1]) > 2\delta$ . Then there exists  $z \in [x, y], r \in [x, x_1]$  and  $s \in [y, y_1]$  such that  $d(z, r) \leq 2\delta$  and  $d(z, s) \leq 2\delta$ .*

*Proof.* The proof is that same as the proof of the lemma 2.1.

By the lemma 2.2, every point  $z \in [x, y]$  is at a distance at most  $2\delta$  of  $[x, x_1] \cup [x_1, y_1] \cup [y_1, y]$ . But, by hypothesis, for all  $z \in [x, y], d(z, [x_1, y_1]) > 2\delta$ , so for all  $z \in [x, y]$ , there exists  $z' \in [x, x_1] \cup [y_1, y]$  such that  $d(z, z') \leq 2\delta$ .

Consider :

$$\begin{aligned} L &= \{z \in [x, y] : \exists r \in [x, x_1], d(z, r) \leq 2\delta\} \\ R &= \{z \in [x, y] : \exists s \in [y, y_1], d(z, s) \leq 2\delta\} \end{aligned}$$

Then :

- $R$  and  $L$  are non-empty because  $x \in L$  and  $y \in R$ .
- $R$  and  $L$  are closed because  $[x, x_1]$  and  $[y, y_1]$  are compact.
- We have  $[x, y] = R \cup L$  because, by the lemma 2.2, every point of  $[x, y]$  is at a distance at most  $2\delta$  of  $[x, x_1] \cup [x_1, y_1] \cup [y_1, y]$ , and, by hypothesis, every point of  $[x, y]$  is at a distance at least  $2\delta$  of  $[x_1, y_1]$ .

We deduce that  $R \cap L \neq \emptyset$ .

Indeed, if  $R \cap L = \emptyset$ , we would have an open cover of  $[x, y]$  in two disjoint non-empty open sets  $([x, y] \setminus L$  and  $[x, y] \setminus R)$ , which would contradict the connectedness of  $[x, y]$ .

Thus we deduce the existence of  $z \in [x, y]$ ,  $r \in [x, x_1]$  and  $s \in [y, y_1]$  such that  $d(z, r) \leq 2\delta$  and  $d(z, s) \leq 2\delta$ .  $\square$

A quadrilateral  $[x, y, x_1, y_1]$  has thus one of two typical general shapes : the one where a point of  $[x, y]$  is close to a point of  $[x_1, y_1]$  and the one where all points of  $[x, y]$  are far from  $[x_1, y_1]$ . The following lemma clarifies this alternative in terms of comparing the lengths of the sides of the quadrilateral, in the more specific case where  $x_1$  and  $y_1$  are projections of  $x$  and  $y$  on a geodesic.

**Lemma 2.4.** *Let  $X$  be a  $\delta$ -hyperbolic geodesic space and  $l$  a bi-infinite geodesic of  $X$ . Let  $x$  and  $y$  be two points in  $X$ . Let  $K_x = d(x, l)$ ,  $K_y = d(y, l)$  and  $d = d(x, y)$ . Consider  $x_1$  and  $y_1$  two projection of  $x$  and  $y$  on  $l$ , that is two points  $x_1, y_1 \in l$  satisfying  $d(x, x_1) = K_x$  and  $d(y, y_1) = K_y$ . We denote by  $[x_1, y_1]$  the geodesic segment included in  $l$  with endpoints  $x_1$  and  $y_1$ .*

- If  $\exists z \in [x, y], d(z, [x_1, y_1]) \leq 2\delta$ , then  $d \geq K_x + K_y - 4\delta$
- If  $\forall z \in [x, y], d(z, [x_1, y_1]) > 2\delta$ , then  $d \leq K_x + K_y + 4\delta$

*Proof.* • Suppose that there exists  $z \in [x, y]$  and  $z_1 \in [x_1, y_1]$  such that  $d(z, z_1) \leq 2\delta$ . By definition,  $x_1$  minimizes the distance from  $x$  to  $l$ , and  $z_1 \in l$  so  $d(x, z_1) \geq K_x$ . Then :

$$d(x, z) \geq d(x, z_1) - d(z, z_1) \geq K_x - 2\delta \quad (2.1)$$

Similarly, since  $y_1$  minimizes the distance from  $y$  to  $l$ , we get :

$$d(z, y) \geq d(y, z_1) - d(z, z_1) \geq K_y - 2\delta \quad (2.2)$$

Thus, since  $z \in [x, y]$ , we obtain by combining (2.1) and (2.2) :

$$d = d(x, y) = d(x, z) + d(z, y) \geq K_x + K_y - 4\delta$$

- Suppose that for all  $z \in [x, y]$ ,  $d(z, [x_1, y_1]) > 2\delta$ . Then by the lemma 2.3, there exists  $z \in [x, y]$ ,  $r \in [x, x_1]$  and  $s \in [y, y_1]$  such that  $d(z, r) \leq 2\delta$  and  $d(z, s) \leq 2\delta$ . Hence we have on one hand :

$$\begin{aligned} d(x, z) &\leq d(x, r) + d(r, z) \\ &= d(x, x_1) - d(r, x_1) + d(r, z) && \text{because } r \in [x, x_1] \\ &\leq K_x + 2\delta && \text{since } d(r, z) \leq 2\delta. \end{aligned}$$

On the other hand, we obtain in the same way :

$$d(z, y) \leq K_y + 2\delta$$

and then :

$$d = d(x, z) + d(z, y) \leq K_x + K_y + 4\delta.$$

□

The following lemma and corollary aim to bound, in the same context as in the previous lemma, the distance between  $x_1$  and  $y_1$ .

**Lemma 2.5.** *Let  $X$  be a  $\delta$ -hyperbolic geodesic space, and  $l$  a bi-infinite geodesic of  $X$ . Let  $x$  and  $y$  be two points in  $X$ , denote  $K_x = d(x, l)$  and  $K_y = d(y, l)$ . Consider  $x_1$  and  $y_1$  two projections of  $x$  and  $y$  on  $l$ , that is two points  $x_1, y_1 \in l$  satisfying  $d(x, x_1) = K_x$  and  $d(y, y_1) = K_y$ . We denote by  $[x_1, y_1]$  the geodesic segment included in  $l$  with endpoints  $x_1$  and  $y_1$ . We let  $d = d(x, y)$  and  $d_1 = d(x_1, y_1)$ . Then we have the following alternative :*

- If  $\forall z \in [x_1, y_1]$ ,  $d(z, [x, y]) > 2\delta$ , then  $d_1 \leq 8\delta$ .
- If  $\exists z \in [x_1, y_1]$ ,  $d(z, [x, y]) \leq 2\delta$ , then  $d_1 \leq d - K_x - K_y + 12\delta$ .

In particular, we always have the inequality  $d_1 \leq d + 12\delta$ .

*Proof.* • Suppose that for all  $z \in [x_1, y_1]$  one has  $d(z, [x, y]) > 2\delta$ . Denote  $[x, x_1]$  (respectively  $[y, y_1]$ ) a geodesic segment with endpoints  $x$  and  $x_1$  (respectively  $y$  and  $y_1$ ), then, by the lemma 2.3 the exists  $z \in [x_1, y_1]$ ,  $s \in [x, x_1]$  and  $r \in [y, y_1]$  such that  $d(z, s) \leq 2\delta$  and  $d(z, r) \leq 2\delta$ . Therefore

$$\begin{aligned} d(x_1, z) &\leq d(x_1, s) + d(s, z) \\ &\leq d(x_1, s) + 2\delta && \text{because } d(s, z) \leq 2\delta \\ &= d(x, x_1) - d(x, s) + 2\delta && \text{since } s \in [x, x_1] \\ &\leq d(x, x_1) - d(x, z) + 2\delta + 2\delta && \text{because } d(x, z) \leq d(x, s) + d(s, z) \leq d(x, s) + 2\delta. \end{aligned}$$

But  $x_1$  is a projection of  $x$  to  $l$  and  $z \in l$ , so  $d(x, x_1) \leq d(x, z)$ . Thus :

$$d(x_1, z) \leq 4\delta. \tag{2.3}$$

Similarly, we show that :

$$d(z, y_1) \leq 4\delta. \quad (2.4)$$

Thus, by summing (2.3) and (2.4), we obtain :

$$d_1 \leq 8\delta.$$

- Suppose that there exists  $z \in [x, y]$  and  $z_1 \in [x_1, y_1]$  such that  $d(z, z') \leq 2\delta$ . Consider  $[x, z_1]$  a geodesic segment with endpoints  $x$  and  $z_1$ . The triangle  $[x, x_1, z_1]$  is  $\delta$ -thin so, by the lemma 2.1 there exists  $r \in [x, x_1]$ ,  $s \in [x, z_1]$  and  $t \in [x_1, z_1]$  such that  $d(t, r) \leq \delta$  and  $d(t, s) \leq \delta$ . In particular,  $d(r, s) \leq 2\delta$ . Thus, we have :

$$\begin{aligned} d(x_1, t) &\leq d(x_1, r) + d(r, t) \\ &\leq d(x_1, r) + \delta \quad \text{because } d(r, t) \leq \delta \\ &= d(x, x_1) - d(x, r) + \delta \quad \text{because } r \in [x, x_1] \\ &\leq d(x, x_1) - d(x, t) + \delta + \delta \quad \text{since } d(x, t) \leq d(x, r) + d(r, t) \leq d(x, r) + \delta \end{aligned}$$

But  $x_1$  is a projection of  $x$  on  $l$  and  $t \in l$  so  $d(x, x_1) \leq d(x, t)$ . Thus :

$$d(x_1, t) \leq 2\delta. \quad (2.5)$$

Furthermore :

$$\begin{aligned} d(t, z_1) &\leq d(t, s) + d(s, z_1) \\ &\leq \delta + d(s, z_1) \quad \text{because } d(t, s) \leq \delta \\ &= d(x, z_1) - d(x, s) + \delta \quad \text{since } s \in [x, z_1] \\ &\leq d(x, z) + d(z, z_1) - d(x, t) + \delta + \delta \quad \text{because } d(x, t) \leq d(x, s) + d(s, t) \leq d(x, s) + \delta \\ &\leq d(x, z) + 2\delta - d(x, t) + 2\delta \quad \text{since } d(z, z_1) \leq 2\delta \end{aligned}$$

and  $d(x, t) \geq d(x, x_1) = K_x$ , so

$$d(t, z_1) \leq d(x, z) - K_x + 4\delta. \quad (2.6)$$

Thus, combining (2.5) and (2.6), we get:

$$d(x_1, z_1) = d(x_1, t) + d(t, z_1) \leq d(x, z) - K_x + 6\delta \quad (2.7)$$

By the same reasoning, considering the triangle  $[y, y_1, z_1]$ , we get :

$$d(z_1, y_1) \leq d(z, y) - K_y + 6\delta \quad (2.8)$$

We deduce, using (2.7) and (2.8) :

$$\begin{aligned} d_1 &= d(x_1, z_1) + d(z_1, y_1) \\ &\leq d(x, z) - K_x + 6\delta + d(z, y) - K_y + 6\delta \\ &= d(x, y) - K_x - K_y + 12\delta \quad \text{car } z \in [x, y] \end{aligned}$$

Thus :

$$d_1 \leq d - K_x - K_y + 12\delta.$$

□

Thus, we deduce an upper bound on  $d_1$  depending only on the hyperbolic constant  $\delta$  in the case when  $d \leq K_x + K_y + 6\delta$ . (The choice of this particular threshold on  $d$  comes from the disjunction made in the proposition 2.11 at the end of this section.)

**Corollary 2.6.** *Let  $X$  be a  $\delta$ -hyperbolic geodesic space, and  $l$  a bi-infinite geodesic of  $X$ . Let  $x$  and  $y$  be two points in  $X$ , denote  $K_x = d(x, l)$  and  $K_y = d(y, l)$ . Consider  $x_1$  and  $y_1$  two projections of  $x$  and  $y$  on  $l$ , that is two points  $x_1, y_1 \in l$  satisfying  $d(x, x_1) = K_x$  and  $d(y, y_1) = K_y$ . Denote  $d = d(x, y)$  and  $d_1 = d(x_1, y_1)$ . Then :*

$$\text{If } d \leq K_x + K_y + 6\delta, \text{ then } d_1 \leq 18\delta.$$

*Proof.* According to the lemma 2.5, we have  $d_1 \leq \max(8\delta, d - K_x - K_y + 12\delta)$ . But  $d \leq K_x + K_y + 6\delta$ , so

$$d_1 \leq \max(8\delta, d - K_x - K_y + 12\delta) \leq \max(8\delta, 18\delta) = 18\delta.$$

□

The following lemmas, 2.7, 2.8 and 2.10, as well as the propositions 2.9 and 2.11, aim at bounding from below the length of a path remaining at a distance at least  $K$  from a given geodesic. This first lemma, which is a first step, minimizes this length using the distance of a point  $z$  on a geodesic connecting the extremal points of the path and a point on the path.

**Lemma 2.7.** *Let  $X$  be a  $\delta$ -hyperbolic geodesic space,  $l$  a bi-infinite geodesic of  $X$  and  $K > 0$ . Consider  $f : [a, b] \rightarrow X$  a continuous rectifiable path such that :*

$$\forall t \in [a, b], \quad d(f(t), l) \geq K$$

*Let  $x = f(a), y = f(b)$  and consider  $[x, y]$  a geodesic segment with endpoints  $x$  and  $y$ . Denote  $L = \text{length}(f([a, b]))$  and suppose  $L > 2\delta$ .*

*Then, for all  $z \in [x, y]$ , there exists  $t \in [a, b]$  such that :*

$$L \geq (2^{\frac{d(z, f(t))}{\delta} - 1} - 2)\delta.$$

*Proof.* Since the path  $f([a, b])$  is rectifiable, there exists a subdivision of  $f([a, b])$  in  $n$  arcs, each of length  $2\delta$  except possibly the last one of length smaller than  $2\delta$  (then  $n = \lceil \frac{L}{2\delta} \rceil$ ). Denote by  $y_0 = x, y_1, \dots, y_n = y$  the points of this subdivision and consider  $Y = [y_0, y_1] \cup [y_1, y_2] \cup \dots \cup [y_{n-1}, y_n]$  the chain of  $n$  geodesic segments connecting these points.

We can therefore bound the length of the path  $f([a, b])$  from below by the length of the first  $n - 1$  paths of this subdivision:

$$L \geq (n - 1)2\delta \tag{2.9}$$

The hypothesis  $L > 2\delta$  allows us to assert that  $n \geq 2$ . Then there exists  $k \geq 1$  such that  $2^{k-1} < n \leq 2^k$ . We deduce :

$$L \geq (2^{k-1} - 1)2\delta = (2^k - 2)\delta \quad (2.10)$$

We can apply the lemma 2.2 to  $z \in [y_0, y_n]$  and  $Y$  : there exists  $p \in Y$  such that  $d(z, p) \leq k\delta$ . Moreover, there exists  $i \in \{0, n-1\}$  such that  $p \in [y_i, y_{i+1}]$ , and  $d(y_i, y_{i+1}) \leq 2\delta$  (because the distance between  $y_i$  and  $y_{i+1}$  is in particular smaller than  $2\delta$ ) so, there exists  $j \in \{0, n\}$  such that  $d(p, y_j) \leq \delta$ .

Let  $z \in [x, y]$ . Then, by the triangle inequality, we obtain the upper bound  $d(z, y_j) \leq d(z, p) + d(p, y_j) \leq k\delta + \delta = (k+1)\delta$  from which we deduce  $k \geq d(z, y_j)/\delta - 1$ . Moreover, since  $y_j \in f([a, b])$ , we deduce the existence of  $t \in [a, b]$  such that  $y_j = f(t)$ . Thus from the inequality (2.10) we obtain the desired inequality:

$$L \geq (2^{\frac{d(z, f(t))}{\delta} - 1} - 2)\delta.$$

□

Now, we try to give a lower bound on the term  $d(z, f(t))$  in the previous lemma 2.7. We give two lower bounds according to the shape of the quadrilateral.

**Lemma 2.8.** *Let  $X$  be a  $\delta$ -hyperbolic geodesic space,  $l$  a bi-infinite geodesic of  $X$  and  $K > 0$ . Consider  $f : [a, b] \rightarrow X$  a continuous rectifiable path such that :*

$$\forall t \in [a, b], \quad d(f(t), l) \geq K.$$

Denote  $x = f(a), y = f(b), d = d(x, y), K_x = d(x, l), K_y = d(y, l)$  and  $L = \text{length}(f([a, b]))$ . Let  $x_1$  and  $y_1$  be two projections of  $x$  and  $y$  on  $l$ .

Consider  $[x, y]$  a geodesic segment with endpoints  $x$  and  $y$  and  $[x_1, y_1]$  the geodesic segment included in  $l$  with endpoints  $x_1$  and  $y_1$ .

We can bound from below the distance from a point  $z$  of  $[x, y]$  to any point on the path  $f([a, b])$  in the following two cases :

- Suppose that  $\forall z \in [x, y], d(z, [x_1, y_1]) > 2\delta$ . Then :

$$\exists z \in [x, y], \forall t \in [a, b], d(z, f(t)) \geq \frac{d}{2} + K - \frac{1}{2}(K_x + K_y) - 4\delta \quad (2.11)$$

In particular, if  $K_x = K_y = K$ , we have :

$$\exists z \in [x, y], \forall t \in [a, b], d(z, f(t)) \geq \frac{d}{2} - 4\delta \quad (2.12)$$

- Suppose that  $\exists z \in [x, y], d(z, [x_1, y_1]) \leq 2\delta$ . Then :

$$\exists z \in [x, y], \forall t \in [a, b], d(z, f(t)) \geq K - 2\delta \quad (2.13)$$

*Proof.* • Suppose that  $\forall z \in [x, y], d(z, [x_1, y_1]) > 2\delta$ . Then, considering a quadrilateral with vertices  $x, x_1, y_1, y$  (in this order), we deduce by the lemma 2.3 the existence of  $z \in [x, y], r \in [x, x_1]$  and  $s \in [y, y_1]$  such that  $d(z, r) \leq 2\delta$  and  $d(z, s) \leq 2\delta$ . Let  $t \in [a, b]$ . Then :

$$\begin{aligned}
K &\leq d(f(t), l) && \text{by hypothesis} \\
&\leq d(f(t), x_1) && \text{because } x_1 \in l \\
&\leq d(f(t), z) + d(z, r) + d(r, x_1) && \text{by the triangle inequality} \\
&\leq d(f(t), z) + 2\delta + d(r, x_1) && \text{because } d(z, r) \leq 2\delta \\
&= d(f(t), z) + 2\delta + d(x, x_1) - d(x, r) && \text{because } r \in [x, x_1] \\
&\leq d(f(t), z) + 2\delta + K_x - d(x, r) && \text{since } x_1 \text{ is a projection of } x \text{ on } l \\
&\leq d(f(t), z) + 2\delta + K_x - d(x, z) + d(z, r) && \text{by the triangle inequality} \\
&\leq d(f(t), z) + 2\delta + K_x - d(x, z) + 2\delta && \text{because } d(z, r) \leq 2\delta.
\end{aligned}$$

We deduce :

$$d(x, z) + K - K_x - 4\delta \leq d(f(t), z). \quad (2.14)$$

By analogous reasoning changing  $x$  to  $y$ ,  $x_1$  to  $y_1$ ,  $r$  to  $s$  and  $K_x$  to  $K_y$ , we also get :

$$d(z, y) + K - K_y - 4\delta \leq d(f(t), z). \quad (2.15)$$

Thus, averaging the inequalities (2.14) and (2.15), and since  $d = d(x, y) = d(x, z) + d(z, y)$  we obtain the desired inequality :

$$\frac{d}{2} + K - \frac{1}{2}(K_x + K_y) - 4\delta \leq d(f(t), z).$$

- Suppose that  $\exists z \in [x, y], d(z, [x_1, y_1]) \leq 2\delta$ . Then let  $z' \in [x_1, y_1]$  such that  $d(z, z') \leq 2\delta$ . Let  $t \in [a, b]$ . We have :

$$\begin{aligned}
K &\leq d(f(t), z') && \text{because } z' \in l \\
&\leq d(f(t), z) + d(z, z') && \text{by the triangle inequality} \\
&\leq d(f(t), z) + 2\delta && \text{because } d(z, z') \leq 2\delta
\end{aligned}$$

We have indeed shown that

$$d(f(t), z) \geq K - 2\delta.$$

□

The following proposition is a direct consequence of the two previous lemmas. It gives a lower bound on the length of a path remaining at a distance at least  $K$  from a geodesic as a function of the distance between the extremal points of the path, the distances of the extremal points to the geodesic and  $K$ .

**Proposition 2.9.** *Let  $X$  be a  $\delta$ -hyperbolic geodesic space,  $l$  a bi-infinite geodesic of  $X$  and  $K > 0$ . Consider  $f : [a, b] \rightarrow X$  a continuous rectifiable path such that :*

$$\forall t \in [a, b], \quad d(f(t), l) \geq K$$

Denote  $x = f(a), y = f(b), d = d(x, y), K_x = d(x, l), K_y = d(y, l)$  and  $L = \text{length}(f([a, b]))$  and suppose that  $L > 2\delta$ . Let  $x_1$  and  $y_1$  be some projections of  $x$  and  $y$  on  $l$ . Consider  $[x, y]$  a geodesic segment with endpoints  $x$  and  $y$  and  $[x_1, y_1]$  the geodesic segment included in  $l$  with endpoints  $x_1$  and  $y_1$ .

- Suppose that  $\forall z \in [x, y], d(z, [x_1, y_1]) > 2\delta$ . Then :

$$L \geq (2^{\frac{d-K_x-K_y+2K}{2\delta}-5} - 2)\delta \quad (2.16)$$

In particular, if  $K_x = K_y = K$ , then :

$$L \geq (2^{\frac{d}{2\delta}-5} - 2)\delta \quad (2.17)$$

- Suppose that  $\exists z \in [x, y], d(z, [x_1, y_1]) \leq 2\delta$ . Then :

$$L \geq (2^{\frac{K}{\delta}-3} - 2)\delta \quad (2.18)$$

*Proof.*

- Suppose that  $\forall z \in [x, y], d(z, [x_1, y_1]) > 2\delta$ .

According to the property (2.11) of the lemma 2.8 , there exists  $z \in [x, y]$  such that for all  $t \in [a, b], d(z, f(t)) \geq \frac{d}{2} + K - \frac{1}{2}(K_x + K_y) - 4\delta$ . Then, by the lemma 2.7, we obtain the existence of  $t \in [a, b]$  such that

$$L \geq (2^{\frac{d(z, f(t))}{\delta}-1} - 2)\delta.$$

Indeed we have :

$$L \geq (2^{\frac{\frac{d}{2} + K - \frac{1}{2}(K_x + K_y) - 4\delta}{\delta} - 1} - 2)\delta = (2^{\frac{d-K_x-K_y+2K}{2\delta}-5} - 2)\delta.$$

- Suppose that  $\exists z \in [x, y], d(z, [x_1, y_1]) \leq 2\delta$ .

According to the property (2.13) of the lemma 2.8, there exists  $z \in [x, y]$  such that for all  $t \in [a, b], d(z, f(t)) \geq K - 2\delta$ . Then, by the lemma 2.7, we obtain the existence of  $t \in [a, b]$  such that

$$L \geq (2^{\frac{d(z, f(t))}{\delta}-1} - 2)\delta.$$

Indeed we have :

$$L \geq (2^{\frac{K-2\delta}{\delta}-1} - 2)\delta = (2^{\frac{K}{\delta}-3} - 2)\delta.$$

□



The following lemma gives a lower bound on the length of a path remaining at a distance at least  $K$  from a geodesic in the specific case where the distance between the endpoints is known as a function of the distances of the endpoints to the geodesic.

**Lemma 2.10.** *Let  $X$  be a  $\delta$ -hyperbolic geodesic,  $l$  a bi-infinite geodesic of  $X$  and  $K > 0$ . Consider  $f : [a, b] \rightarrow X$  a continuous rectifiable path such that :*

$$\forall t \in [a, b], \quad d(f(t), l) \geq K$$

Denote  $x = f(a), y = f(b), d = d(x, y), K_x = d(x, l), K_y = d(y, l)$  and  $L = \text{length}(f([a, b]))$  and suppose that  $L > 2\delta$ .

Assume that  $d = K_x + K_y + 6\delta$ , then :

$$L \geq (2^{\frac{K}{\delta}-3} - 2)\delta$$

*Proof.* Let  $x_1$  and  $y_1$  be two projections of  $x$  and  $y$  on  $l$ .

Consider  $[x, y]$  a geodesic segment with endpoints  $x$  and  $y$  and  $[x_1, y_1]$  the geodesic segment included in  $l$  with endpoints  $x_1$  and  $y_1$ .

We distinguish two cases :

- If  $\exists z \in [x, y], d(z, [x_1, y_1]) \leq 2\delta$ , then the inequality (2.18) of the proposition 2.9 gives

$$L \geq (2^{\frac{K}{\delta}-3} - 2)\delta.$$

- If  $\forall z \in [x, y], d(z, [x_1, y_1]) > 2\delta$ , then the inequality (2.16) of the proposition 2.9 gives :

$$\begin{aligned} L &\geq (2^{\frac{d-K_x-K_y+2K}{2\delta}-5} - 2)\delta \\ &\geq (2^{\frac{6\delta+2K}{2\delta}-5} - 2)\delta \text{ because } d = K_x + K_y + 6\delta \\ &\geq (2^{\frac{K}{\delta}-3} - 2)\delta. \end{aligned}$$

□

The following proposition is the most important one in this section. It gives a lower bound on the length of a path remaining at a distance at least  $K$  from a geodesic and whose extremal points are "approximately" at distance  $K$  from this geodesic. It distinguishes two regimes : one when the distance to the geodesic is very large compared to the distance between the extremal points and the other in the opposite case. In the first case, the path length grows exponentially with the distance between the extremal points and in the second case, this growth is linear, but with a large constant.

**Proposition 2.11.** *Let  $X$  be a  $\delta$ -hyperbolic geodesic space,  $l$  a bi-infinite geodesic of  $X$ ,  $K > 0$  and  $C > 0$  two constants. Consider  $f : [a, b] \rightarrow X$  a continuous rectifiable path such that :*

$$\begin{aligned} \forall t \in [a, b], \quad d(f(t), l) &\geq K \\ d(f(a), l) &\leq K + C \\ d(f(b), l) &\leq K + C \end{aligned}$$

Denote  $x = f(a), y = f(b), d = d(x, y)$  and  $L = \text{length}(f([a, b]))$ .

- Suppose that  $d \leq 2K + 6\delta$ . Then, after denoting  $D = \max(C, \delta)$  :

$$L \geq (2^{\frac{d}{2\delta} - \frac{D}{\delta} - 5} - 2)\delta \quad (2.19)$$

- Suppose that  $d > 2K + 6\delta$ . Then there exists an integer  $n \geq 2$  such that :

$$\begin{cases} L \geq (n-1)(2^{\frac{K}{\delta} - 3} - 2)\delta \\ d \leq 18n\delta + 2K + 2C \end{cases} \quad (2.20)$$

In particular, we deduce :

$$L \geq \frac{1}{18}(d - 2K - 2C - 18\delta)(2^{\frac{K}{\delta} - 3} - 2) \quad (2.21)$$

*Proof.* Let us first treat separately the case where  $L \leq 2\delta$ . In this case, we also have  $d \leq 2\delta$ . Then  $d \leq 2K + 6\delta$  on one hand, and on the other hand  $(2^{\frac{d}{2\delta} - 6} - 2)\delta \leq (2^{-5} - 2)\delta < 0 \leq L$ , so (2.19) holds. Let us now suppose that  $L > 2\delta$ . Denote  $K_x = d(x, l)$  and  $K_y = d(y, l)$ . Then by hypothesis,  $K_x - K \leq C$  and  $K_y - K \leq C$ .

- Suppose that  $d \leq 2K + 6\delta$ .

- Suppose that  $\forall z \in [x, y], d(z, [x_1, y_1]) > 2\delta$ . Then, according to the inequality (2.16) of the lemma 2.9, we have :

$$L \geq (2^{\frac{d - K_x - K_y + 2K}{2\delta} - 5} - 2)\delta \geq (2^{\frac{d - 2C}{2\delta} - 5} - 2)\delta \geq (2^{\frac{d}{2\delta} - \frac{C}{\delta} - 5} - 2)\delta \geq (2^{\frac{d}{2\delta} - \frac{D}{\delta} - 5} - 2)\delta.$$

- Suppose that  $\exists z \in [x, y], d(z, [x_1, y_1]) \leq 2\delta$ . Then, according to the inequality (2.18) of the lemma 2.9, we have :

$$L \geq (2^{\frac{K}{\delta} - 3} - 2)\delta \geq (2^{\frac{\frac{d}{2} - 3\delta}{\delta} - 3} - 2)\delta \geq (2^{\frac{d}{2\delta} - 6} - 2)\delta \geq (2^{\frac{d}{2\delta} - \frac{D}{\delta} - 5} - 2)\delta.$$

- Suppose that  $d > 2K + 6\delta$ .

Let  $t_0 \in [a, b]$  and  $x_0 = f(t_0)$ . Let us consider :

$$g_{t_0}(t) = d(x_0, f(t)) - d(x_0, l) - d(f(t), l) - 6\delta.$$

The map  $g_{t_0}$  is continuous on  $[t_0, b]$  and  $g_{t_0}(t_0) = d(x_0, x_0) - d(x_0, l) - d(x_0, l) - 6\delta = -2d(x_0, l) - 6\delta < 0$ . Then if  $g_{t_0}(b) \geq 0$ , there exists, by the intermediate value theorem,  $t_1 \in (t_0, b]$  such that  $g_{t_0}(t_1) = 0$ . Since  $g_a(b) = d(x, y) - d(x, l) - d(y, l) - 6\delta = d - 2K - 6\delta \geq 0$  by hypothesis, we can find a sequence of points  $t_0, t_1, \dots, t_n$  in  $[a, b]$  such that, denoting  $x_i = f(t_i)$ ,  $d_i = d(x_i, x_{i+1})$  and  $K_i = d(x_i, l)$  we have :

- $t_0 = a, t_n = b$

- $\forall i \in \{0, n-2\}, g_{t_i}(t_{i+1}) = 0$ , namely  $d_i = K_i + K_{i+1} + 6\delta$
- $d_{n-1} < K_{n-1} + K_n + 6\delta$ .

Let  $L_i = \text{length}(f([t_i, t_{i+1}]))$ , we can use lemma 2.10 between  $x_i$  and  $x_{i+1}$  to show that  $L_i \geq (2^{\frac{K}{\delta}-3} - 2)\delta$  as soon as  $i \in \{0, n-2\}$ . This justifies in particular that the number  $n$  of points cutting the path  $f$  as above is indeed finite. Moreover, the hypothesis  $d > 2K + 6\delta$  implies that  $n \geq 2$ .

Thus we can lower bound the length of the path  $f$  on  $[a, b]$  by :

$$L = \sum_{i=0}^{n-1} L_i \geq \sum_{i=0}^{n-2} L_i \geq (n-1)(2^{\frac{K}{\delta}-3} - 2)\delta$$

which indeed gives us the first inequality of (2.20).

Now consider for all  $i \in \{0, \dots, n\}$ ,  $p_i$  a projection of  $x_i$  on  $l$  (we choose in particular  $p_0 = x_1$  and  $p_n = y_1$ ). Denote  $d_{1,i} = d(p_i, p_{i+1})$ . Since  $d_i \leq K_i + K_{i+1} + 6\delta$ , for all  $i \in \{0, \dots, n-1\}$ , the corollary 2.6 states that  $d_{1,i} \leq 18\delta$ . Therefore :

$$d_1 = d(x_1, y_1) = d(p_0, p_n) \leq \sum_{i=0}^{n-1} d(p_i, p_{i+1}) = \sum_{i=0}^{n-1} d_{1,i} \leq 18n\delta.$$

Thus :

$$\begin{aligned} d &= d(x, y) \text{ by definition} \\ &\leq d(x, x_1) + d(x_1, y_1) + d(y_1, y) \text{ by the triangle inequality} \\ &= d_1 + 2K + 2C \\ &\leq 18n\delta + 2K + 2C \text{ by the inequality (2.1)} \end{aligned}$$

which indeed gives us the second inequality of (2.20).

The inequality (2.21) is immediate using the two inequalities of (2.20).

□

## 2.2 Isometries, stable length and local-global Lemma

In this short section, we gather together a few results about isometries and quasi-geodesics in a  $\delta$ -hyperbolic space.

The fundamental result is that isometries of a  $\delta$ -hyperbolic space can be classified as follows : the *elliptic* ones, whose orbits are bounded, the *parabolic* ones, which admit a unique accumulation point in the boundary  $\partial X$ , and the *hyperbolic* ones, for which, denoting  $A$  the isometry and  $o$  any basepoint in  $X$ , the map from  $\mathbb{Z}$  to  $X$  which send  $n$  to  $A^n o$  is a quasi-isometry embedding. In particular, when  $A$  is a hyperbolic isometry of  $X$ , it has exactly two fixed points in the boundary

of  $X$ , one attracting and the other repelling, denoted by  $A^+$  and  $A^-$  respectively.

When given any isometry  $A$  in the metric space  $X$ , we have already defined in the introduction its *displacement length* (see section 1.2), and this notion has been used to define *Bowditch representations* (see definition 1.1). We can also consider its *stable length*, which is defined by

$$l_S(A) = \lim_{n \rightarrow \infty} \frac{1}{n} d(A^n o, o). \quad (2.22)$$

It is not hard to check that the stable length is well-defined and invariant under the choice of the basepoint  $o$  in  $X$ . The stable length is in general distinct from the displacement length, although in the hyperbolic  $n$ -space  $\mathbb{H}^n$  these notions coincide. Moreover, it satisfies  $l_S(A^n) = n l_S(A)$ , whereas this equality is not true in general for the displacement length, unlike the case of  $\mathbb{H}^n$ . The stable length is the right notion to determine the hyperbolicity of an isometry : an isometry  $A$  is hyperbolic if and only if  $l_S(A) > 0$ , whereas this equivalence is not true in general when considering the displacement length. Finally, we can compare the displacement and the stable length, with the following inequality ([CDP90], Chapter 10, §6, Proposition 6.4) :

$$l_S(A) \leq l(A) \leq l_S(A) + 16\delta \quad (2.23)$$

The left inequality follows directly from the definitions, hence is true in any metric space, whereas the right inequality is really a feature of  $\delta$ -hyperbolicity.

The proofs of all these facts about the isometries of  $X$  and the stable length can be found in [CDP90], Chapter 9 and 10.6.

Recall we defined in the introduction quasi-isometric embeddings between metric spaces (see Definition 1.2). We now define a *quasi-geodesic* of a metric space  $X$  to be a quasi-isometric embedding of  $\mathbb{R}$  endowed with its usual distance into  $X$ . More precisely, we say that  $f : \mathbb{R} \rightarrow X$  is a  $(\lambda, k)$ -*quasi-geodesic*, if, for any  $t, t'$  in  $\mathbb{R}$ , we have the inequality :

$$\frac{1}{\lambda} |t - t'| - k \leq d(f(t), f(t')) \leq \lambda |t - t'| + k. \quad (2.24)$$

There is also a notion of *local-quasi-geodesics* : we say that  $f : \mathbb{R} \rightarrow X$  is a  $(\lambda, k, L)$ -*local-quasi-geodesic* if, for any  $t, t'$  in  $\mathbb{R}$ , the above inequality (2.24) is satisfied whenever  $|t - t'| \leq L$ .

Global-quasi-geodesics are trivially local-quasi-geodesic, for any  $L$ . The Local-Global Lemma enables us to pass from local-quasi-geodesicity to global quasi-geodesicity, under the assumption of hyperbolicity.

**Lemma 2.12** (Local-Global, [CDP90], Chapter 3, Theorem 1.4). *Let  $X$  be a geodesic  $\delta$ -hyperbolic space. For all pairs  $(\lambda, k)$ , with  $\lambda \geq 1$  and  $k \geq 0$ , there exists a real number  $L$  and a pair  $(\lambda', k')$  such that every  $(\lambda, k, L)$ -local-quasi-geodesic is a  $(\lambda', k')$ -quasi-geodesic (global). Moreover,  $\lambda', k'$  and  $L$  only depend on  $\delta, \lambda$  and  $k$ .*



# Chapter 3

## Bowditch representations and primitive-stable representations

In this section, we gather a few properties on Bowditch and primitive-stable representations. Here we deal with  $\mathbb{F}_2$  and  $\pi_1(S_{0,4})$  at the same time. Hence let us denote  $\Gamma = \mathbb{F}_2$  or  $\pi_1(S_{0,4})$  and

$$\mathcal{S}(\Gamma) = \begin{cases} \mathcal{P}(\mathbb{F}_2) & \text{if } \Gamma = \mathbb{F}_2 \\ \mathcal{S}(S_{0,4}) & \text{if } \Gamma = \pi_1(S_{0,4}) \end{cases} .$$

Let us make a brief comment on the definition of Bowditch representations (see 1.1). Since  $l_\rho(\gamma) = \inf_{o \in X} d(\rho(\gamma)o, o)$ , we immediately deduce that a Bowditch representation of constants  $(C, D)$  satisfies, for any basepoint  $o \in X$  :

$$\forall \gamma \in \mathcal{P}(\mathbb{F}_2), \quad \frac{1}{C} \|\gamma\| - D \leq d(\rho(\gamma)o, o).$$

The latter inequality will be particularly useful in the proofs. Moreover, recall we defined in section 2.2 the stable length (2.22), and stated in the inequality (2.23) that it is comparable to the displacement length, then we can deduce that a Bowditch representation of constants  $(C, D)$  also satisfies :

$$\forall \gamma \in \mathcal{P}(\mathbb{F}_2), \quad \frac{1}{C} \|\gamma\| - D - 16\delta \leq l_S(\rho(\gamma)).$$

Thus, in definition 1.1, we could also use the stable length instead of the displacement length.

### 3.1 The inclusion $\mathcal{PS}(\Gamma, X) \subset \mathcal{BQ}(\Gamma, X)$

Recall that we defined in definitions 1.3 and 1.5 primitive-stability and simple-stability. We prove in this section a first inclusion between primitive-stable (or simple-stable) representations and Bowditch representations. It is quite easy to check that primitive-stable (or simple-stable) representations are in particular Bowditch :

**Lemma 3.1.** *Let  $\rho : \Gamma \rightarrow \text{Isom}(X)$  be a primitive-stable representation. Then  $\rho$  is a Bowditch representation.*

*Proof.* Let  $o \in X$  be a basepoint. Then, there exist two constants  $C$  and  $D$  such that  $\rho$  is primitive-stable with constants  $(C, D)$ . Let  $\gamma \in \mathcal{S}(\Gamma)$  cyclically reduced and  $n \in \mathbb{N}$ . The elements  $1$  and  $\gamma^n$  both belong to the geodesic  $L_\gamma$  in the Cayley graph of  $\Gamma$ , therefore, by primitive-stability :

$$\begin{aligned} & \frac{1}{C} \|\gamma^n\| - D \leq d(\tau_\rho(\gamma^n), \tau_\rho(1)) = d(\rho(\gamma)^n o, o), \\ \text{then, dividing by } n, & \frac{1}{C} \|\gamma\| - \frac{D}{n} \leq \frac{1}{n} d(\rho(\gamma)^n o, o), \\ \text{and taking the limit when } n \rightarrow \infty, & \frac{1}{C} \|\gamma\| \leq l_S(\rho(\gamma)). \\ \text{Using the inequality (2.23),} & \frac{1}{C} \|\gamma\| \leq l(\rho(\gamma)). \end{aligned}$$

Hence  $\rho$  is a Bowditch representation. □

## 3.2 Openness of the set of primitive-stable representations

Here we prove that we can deform primitive-stable representations, in other words that the set of primitive representations is open in the character variety. Recall that the primitive-stability condition is invariant under conjugacy, then the notion of primitive-stability is well-defined in the character variety.

**Proposition 3.2.** *The set  $\mathcal{PS}(\Gamma, X)$  is open in the character variety  $\chi(\Gamma, \text{Isom}(X))$ .*

*Proof.* Let  $\rho : \Gamma \rightarrow \text{Isom}(X)$  be a primitive-stable representation. Denote by  $(C, D)$  the two constants of primitive-stability of  $\rho$ . We want to find an open neighborhood of  $\rho$  in  $\text{Hom}(\Gamma, \text{Isom}(X))$  consisting only of primitive-stable representations. Our open set will be of the following type : For  $L > 0$  and  $\varepsilon > 0$  two positive constants, define

$$\mathcal{V}_\rho(L, \varepsilon) = \{\rho' : \Gamma \rightarrow \text{Isom}(X) \mid \forall u \in \Gamma \quad |u| \leq L \implies d(\rho(u)o, \rho'(u)o) < \varepsilon\}.$$

Recall that  $\text{Hom}(\Gamma, \text{Isom}(X))$  is endowed with the compact-open topology, then  $\mathcal{V}_\rho(L, \varepsilon)$  is an open subset of  $\text{Hom}(\Gamma, \text{Isom}(X))$ . In the following, we will use the local-global lemma, (which we have recalled previously in Lemma 2.12).

Now let us fix  $\varepsilon = 1$  (we could have chosen any other value for  $\varepsilon$ ). The local-global lemma gives the existence of three constants  $L, C', D'$  such that any  $(C, D + 1, L)$ -local-quasi-geodesic is a  $(C', D')$ -quasi-geodesic. Consider  $\mathcal{V}_\rho(L, 1)$ . It is an open neighborhood of  $\rho$ . We will now show that  $\mathcal{V}_\rho(L, 1)$  consists only of primitive-stable representations. Indeed, take  $\rho' \in \mathcal{V}_\rho(L, 1)$ ,  $\gamma \in \mathcal{S}(\Gamma)$  and let  $u$  and  $v$  be two integer points on the geodesic  $L_\gamma$  of the Cayley graph of  $\Gamma$  (recall that  $L_\gamma$

is the axis of  $\gamma$  in the Cayley graph). Then

$$\begin{aligned}
\frac{1}{C}d(u, v) - D &\leq d(\tau_\rho(u), \tau_\rho(v)) && \text{because } \rho \text{ is primitive-stable} \\
&\leq d(\rho(u)o, \rho(v)o) && \text{because } u \text{ and } v \text{ are integer points} \\
&\leq d(\rho(v^{-1}u)o, o) && \text{because } \rho(v^{-1}) \text{ is an isometry} \\
&\leq d(\rho(v^{-1}u)o, \rho'(v^{-1}u)o) + d(\rho'(v^{-1}u)o, o) && \text{by the triangle inequality} \\
&\leq 1 + d(\rho'(u)o, \rho'(v)o) && \text{because } |v^{-1}u| = d(u, v) \leq L \text{ and } \rho' \in \mathcal{V}_\rho(L, 1)
\end{aligned}$$

So we deduce the inequality :

$$\frac{1}{C}d(u, v) - D - 1 \leq d(\rho'(u)o, \rho'(v)o) \tag{3.1}$$

which shows that  $\rho'(L_\gamma)$  is a  $(C, D + 1, L)$  local-quasi-geodesic, hence a  $(C', D')$  quasi-geodesic by the local-global lemma. This shows that  $\rho'$  is primitive-stable and thus that  $\mathcal{V}_\rho(L, 1)$  is an open-neighborhood of  $\rho$  consisting only of primitive-stable representations. Its image under the projection to  $\chi(\Gamma, \text{Isom}(X))$  is again an open neighborhood consisting of primitive-stable representations and thus  $\mathcal{PS}(\Gamma, X)$  is open.  $\square$





# Part I

## The free group of rank two



## Outline of Part I

The goal of this first part of the thesis is to prove Theorem 1.2. Notice that since we showed in section 3.1 the inclusion  $\mathcal{PS}(\mathbb{F}_2, X) \subset \mathcal{BQ}(\mathbb{F}_2, X)$ , we now need to prove the reverse inclusion, which is the most difficult one.

In Chapter 4, we will develop the necessary material and some crucial lemmas about the structure of primitive elements in  $\mathbb{F}_2$ . First, we will explain how to (bijectively) associate a rational number with a primitive element  $\gamma$  in  $\mathbb{F}_2$ , which we will refer to as the slope of  $\gamma$ . The continued fraction expansion of the slope of  $\gamma$  will then be particularly useful when studying the combinatorial structure of  $\gamma$ . Indeed, if  $[n_1, n_2, \dots, n_r]$  denotes the continued fraction expansion of the slope of  $\gamma$ , we will define for each level  $i$  (that is, each integer  $0 \leq i \leq r$ ) two primitive words  $w_i(\gamma)$  and  $w'_i(\gamma)$ , only depending on the integers  $n_1, \dots, n_i$ , such that  $(w_i(\gamma), w'_i(\gamma))$  is a basis of  $\mathbb{F}_2$  and the word  $\gamma$  is a positive word on  $w_i(\gamma), w'_i(\gamma)$ . This will allow us to have an understanding of the combinatorics of  $\gamma$  at different "scales" (see Definition 4.1 and Proposition 4.3). Then, in Proposition 4.6, we will prove a result that will turn out to be a major tool for our proof : a subword of  $\gamma$  of length  $l_i(\gamma)$ , where  $l_i(\gamma)$  is defined as the length of the primitive word  $w_i(\gamma)$ , is, up to changing its last letter, always a cyclic-permutation of  $w_i(\gamma)$ , hence primitive.

In section 5.1 of Chapter 5, we will study a uniform quasi-geodesicity setting which will later appear as a local uniform quasi-geodesicity property of Bowditch representations. In section 5.2, we will show two properties on Bowditch representations. The first one will ensure that the images of primitive elements under a Bowditch representation are always hyperbolic (Lemma 5.2). In particular, denoting  $L_\gamma$  the axis of  $\gamma$  in the Cayley graph of  $\mathbb{F}_2$  and  $\tau_\rho$  the orbit map of a Bowditch representation  $\rho$ , we can deduce that  $\tau_\rho(L_\gamma)$  is always a quasi-geodesic. The second property (Lemma 5.3) will state that the image of a generator of  $\mathbb{F}_2$  by a Bowditch representation do not exchange the fixpoints of the image of the second generator.

Finally Chapters 6 and 7 will be dedicated to proving that a Bowditch representation of  $\mathbb{F}_2$  is primitive-stable. In Chapter 6, we will first prove a slightly weaker statement (Proposition 6.3), which will be the main step for proving Theorem 1.2. It states that the images of the primitive leaves  $L_\gamma$  by the orbit map stay in a uniformly bounded neighborhood of the axes of the primitive elements  $\gamma$ . At last, Chapter 7 will conclude the proof by showing that a Bowditch representation of  $\mathbb{F}_2$  satisfying the conclusion of Proposition 6.3 is primitive-stable.

Let us now detail the strategy of the proof of Proposition 6.3. We fix a Bowditch representation  $\rho$  and we want to show that the image of the orbit map restricted to primitive leaves is contained in a uniform tubular neighborhood of the axes of the images of the primitive elements. We proceed by contradiction and to this purpose we introduce a sequence  $(\gamma_n)_{n \in \mathbb{N}}$  of primitive elements in  $\mathbb{F}_2$  such that the image of the orbit map on the primitive leave  $L_{\gamma_n}$  becomes further and further away from the axis of  $\rho(\gamma_n)$  as  $n$  increases. We will now study the continued fraction expansion of the slope of  $\gamma_n$  which we denote by  $[N_1^n, \dots, N_{r(n)}^n]$ . The uniform quasi-geodesicity setting studied in Lemma 5.1 of Chapter 5, together with Lemma 5.3 and our hypothesis on  $(\gamma_n)_{n \in \mathbb{N}}$ ,

will enable us to deduce the behavior of the continued fraction expansion : the sequences  $(N_i^n)_n$  must be bounded for all  $i$ , and, as a consequence, the depth  $r(n)$  of the continued fraction expansion will tend to infinity (Lemma 6.5). In particular, for all  $i$ , we will obtain a uniform control on the lengths  $l_i(\gamma_n)$  previously defined in Chapter 4. We will next introduce the notion of a  $K$ -excursion of the orbit map (section 6.3 and 6.4), which will be in particular a subpath of some quasi-geodesic  $\tau_\rho(L_\gamma)$  associated to a primitive element  $\gamma$  which will remain at distance at least  $K$  of the axis of  $\rho(\gamma)$ . We will show that we can extract from the sequence  $(\gamma_n)_{n \in \mathbb{N}}$  a sequence of  $K_n$ -excursions as large as we want ( $K_n \rightarrow \infty$ ) in Lemma 6.13. We will also define the notion of an  $\varepsilon$ -quasi-loop, which will be a subword  $u$  of  $\gamma$  such that  $\rho(u)$  does not displace the basepoint much (Definition 6.4). Using the result on lengths of path in  $\delta$ -hyperbolic space proven in Proposition 2.11 of Chapter 2, we will show that large excursions correspond to quasi-loop (with  $\varepsilon > 0$  as small as we want) in Lemma 6.14. As a consequence, we will find a quasi-loop in each  $\gamma_n$  (for large  $n$ ). Then we will be more precise and we will find a quasi-loop inside a cyclic-permutation of  $w_i(\gamma_n)$ , for some  $i$ , of length at least half of the length of  $w_i(\gamma_n)$  (Lemma 6.15). This will rely on Proposition 4.6 of Chapter 4 and on the fact that once found a quasi-loop, we can find many others of smaller lengths "inside" (this idea is based on Lemma 6.11). Then, using our understanding of the structure of the primitive element  $\gamma_n$  at the level  $i$  studied in Chapter 4, we will deduce that a uniformly bounded from below proportion of the word  $\gamma_n$  will consist of disjoint quasi-loops (Lemma 6.17). We will repeat our argument for the remainders in  $\gamma_n$  that do not yet consist of disjoint quasi-loops in order to find an arbitrarily large proportion of the word  $\gamma_n$  consisting of disjoint quasi-loops (Lemma 6.18). To formalise this idea we will use a recursive argument in the proof. This mean that we will find an arbitrarily large proportion of the word  $\gamma_n$  which does not displace the basepoint much, and this will be in contradiction with the Bowditch's hypothesis.

# Chapter 4

## Structure of primitive elements in the free group of rank two

### 4.1 Constructing primitive elements

In this section, we gather some results about primitive elements in  $\mathbb{F}_2$ . Nielsen studied primitivity and automorphisms of free groups (in [Nie18], [Nie24]). The reader may also refer to [Ser85] or [GK11]. First recall that a *primitive element* in  $\mathbb{F}_2$  is an element which is part of some basis of  $\mathbb{F}_2$ . Fix once and for all  $\{a, b\}$  a free generating set of  $\mathbb{F}_2$  (hence  $\mathbb{F}_2 = \langle a, b \rangle$ ). Then, obviously,  $a$  and  $b$  are primitive elements and so are for example  $a^{-1}$ ,  $b^{-1}$ ,  $ab$ ,  $ab^{-1}$ ,  $a^{-1}b^1$  and  $a^n b$ , for all  $n \in \mathbb{Z}$ . Also note that primitivity is invariant by conjugacy. We denote by  $\mathcal{P}(\mathbb{F}_2)$  the set of primitive elements of  $\mathbb{F}_2$ . We will also denote by  $\mathcal{P}(\mathbb{Z}^2)$  the set of primitive elements of  $\mathbb{Z}^2$ , that is, again, the set of elements of  $\mathbb{Z}^2$  which are part of a basis of  $\mathbb{Z}^2$  (or equivalently, the set of elements  $(p, q) \in \mathbb{Z}^2$  such that  $p$  and  $q$  are relatively prime numbers). Consider the abelianisation map :

$$\text{Ab} : \mathbb{F}_2 \longrightarrow \mathbb{Z}^2$$

It is a surjective morphism which sends any basis of  $\mathbb{F}_2$  to a basis of  $\mathbb{Z}^2$  (hence primitive elements of  $\mathbb{F}_2$  to primitive elements of  $\mathbb{Z}^2$ ). Moreover, since  $\mathbb{Z}^2$  is abelian, the values of  $\text{Ab}$  are constant on conjugacy classes, thus we can consider the following map :

$$\tilde{\text{Ab}} : \mathcal{P}(\mathbb{F}_2) / \sim \longrightarrow \mathcal{P}(\mathbb{Z}^2) / \pm$$

where the quotient on the left hand side is taken up to conjugacy and inversion.

**Proposition 4.1.** *The map  $\tilde{\text{Ab}}$  is a bijection. Equivalently, the map*

$$\begin{aligned} \text{Slope} : \mathcal{P}(\mathbb{F}_2) / \sim &\longrightarrow \mathbb{Q} \cup \infty \\ [\gamma] &\longmapsto \frac{p}{q}, \text{ with } (p, q) = \text{Ab}(\gamma) \end{aligned}$$

where the quotient is taken up to conjugacy and inversion, is a bijection.

Thus we have identified primitive elements (up to conjugacy and inversion) with rational numbers. Every rational number has a *continued fraction expansion*, meaning that it can be written in the following way :

$$\frac{p}{q} = n_1 + \frac{1}{n_2 + \frac{1}{\ddots + \frac{1}{n_r}}}$$

with  $n_1 \in \mathbb{Z}, n_i \in \mathbb{N}^*$  for  $i \geq 2$  and  $n_r \geq 2$ . Denote this expansion by  $[n_1, n_2, \dots, n_r]$ . The continued fraction expansion of the slope will play a central role when studying the general structure of primitive elements. We will now give the general structure of a primitive element in  $\mathbb{F}_2$ .

Consider  $w \in \mathbb{F}_2$ . If  $w$  is primitive, then,  $w$  is either a word on  $\{a, b\}$ , on  $\{a^{-1}, b^{-1}\}$ , on  $\{a, b^{-1}\}$ , or on  $\{a^{-1}, b\}$ . In the first two cases, the slope of  $w$  is positive and in the two last ones, negative. Thus up to inversion,  $w$  can be written as a word on  $\{a, b\}$  (positive slope), or  $\{a, b^{-1}\}$  (negative slope). For simplicity, in the following we will only consider positive slope (for negative slope, just change  $b$  to  $b^{-1}$ ). We say that a letter  $s$  is *isolated* in a (cyclic) word  $w$ , if between two appearances of  $s$  there is at least another letter. We say that a word  $w$  in  $\{a, b\}$ , seen as a cyclic word (not necessarily primitive) is *almost constant* if the two following conditions are satisfied :

- Either the letter  $a$  or  $b$  is isolated in  $w$
- After possibly exchanging  $a$  and  $b$ , suppose that  $b$  is isolated in  $w$ . Then the powers of  $a$  that arise in  $w$  can only be two consecutive integers.

In this case we say that the smallest integer that arises in  $w$  as a power of  $a$  is the *value* of  $w$ . In other words, a word  $w$  in  $a$  and  $b$  is *almost constant of value*  $n \in \mathbb{N}$  if and only if there exists  $s \in \mathbb{N}$  such that, after possibly exchanging  $a$  and  $b$  and up to conjugacy and inversion,  $w$  is of the form :

$$a^{n_1} b a^{n_2} b \dots a^{n_s} b, \quad \text{with } n_i \in \{n, n+1\}, \quad \forall 1 \leq i \leq s$$

If  $w$  is almost constant, we can consider its *derived word* by replacing the blocks  $a^n b$  by  $b$  and the blocks  $a^{n+1} b$  by  $ab$ . The derived word is still a word on  $a$  and  $b$  and thus can be itself almost constant or not.

We say that a word is *characteristic* if it can be derived arbitrarily many times, until a single letter is obtained. The *values* of a characteristic word is the sequence of values of the almost constant derived words obtained at each step.

**Proposition 4.2.** *Let  $\gamma$  be an element of  $\mathbb{F}_2$ . Then  $\gamma$  is primitive if and only if it is characteristic. Moreover, in this case, the values of the characteristic word  $\gamma$  are  $n_1, n_2, \dots, n_r$ , where  $[n_1, n_2, \dots, n_r]$  is the continued fraction expansion of the slope of  $\gamma$ .*

A proof of this fact is given by Series in [Ser85]. Using this fact, we give as explicit construction of the (conjugacy class of) primitive elements, starting from their slope.

**Definition 4.1.** Let  $\gamma$  be a primitive element in  $\mathbb{F}_2$ . Consider  $[n_1(\gamma), n_2(\gamma), \dots, n_{r(\gamma)}(\gamma)]$  the continued fraction expansion of the slope of  $\gamma$  and assume that  $n_i(\gamma) \geq 0$  (that is  $\text{Slope}(\gamma) \geq 0$ ). We define recursively, for  $0 \leq i \leq r(\gamma)$  the following elements in  $\mathbb{F}_2$  :

$$\begin{aligned} w_0(\gamma) &= a & w'_0(\gamma) &= ab \\ w_i(\gamma) &= w_{i-1}(\gamma)^{n_i(\gamma)-1} w'_{i-1}(\gamma) & w'_i(\gamma) &= w_{i-1}(\gamma)^{n_i(\gamma)} w'_{i-1}(\gamma) \end{aligned}$$

Denote by  $l_i(\gamma)$  and  $l'_i(\gamma)$  the word lengths of  $w_i(\gamma)$  and  $w'_i(\gamma)$  respectively.

As defined, the  $w_i(\gamma)$  are the building blocks of  $\gamma$ . In order to reduce the amount of notation, and when there will be no ambiguity on  $\gamma$ , we will omit the dependence on  $\gamma$  in the notation and write  $r, n_i, w_i, w'_i, l_i, l'_i$ . We can check the following :

**Proposition 4.3.** *The elements  $w_i$  defined previously satisfy :*

1. For all  $0 \leq i \leq r$ ,  $w_i$  and  $w'_i$  are primitive and, for  $i \geq 1$  their continued fraction expansions are respectively  $[n_1, \dots, n_i]$  and  $[n_1, \dots, n_i + 1]$
2.  $w_r = \gamma$  (up to conjugacy and inversion). In particular,  $\gamma$  (or its inverse) has a conjugate which is a positive word in  $\{w_i, w'_i\}$ .
3. For all  $0 \leq i \leq r$ ,  $\{w_i, w'_i\}$  is a free basis of  $\mathbb{F}_2$ .

*Proof.* 1. For  $i = 0$ ,  $w_0 = a$  and  $w'_0 = ab$  are both trivially primitive.

- For  $i = 1$ ,  $w_1 = a^{n_1}b$  and  $w'_1 = a^{n_1+1}b$  are again both primitive and their continued fraction expansions are respectively  $[n_1]$  and  $[n_1 + 1]$ .
  - Suppose that both  $w_{i-1}$  and  $w'_{i-1}$  are primitive and that their continued fraction expansion are respectively  $[n_1, \dots, n_{i-1}]$  and  $[n_1, \dots, n_{i-1} + 1]$ . Then  $w_{i-1}$  and  $w'_{i-1}$  can be derived  $i - 1$  times, to obtain the elements  $a$  and  $ab$  (or  $b$  and  $ba$ , depending on the parity of  $i$ ). Thus, since  $w_i$  and  $w'_i$  are positive words on  $\{w_{i-1}, w'_{i-1}\}$ , they can also be derived  $i - 1$  times, and the  $(i - 1)$  - *st*-derived elements we obtain are  $a^{n_i}b$  and  $a^{n_i+1}b$  (or  $b^{n_i}a$  and  $b^{n_i+1}a$ ). Those last ones can be derived one more time to obtain  $b$  and  $ba$  (or  $a$  and  $ab$ ) and we have proved that  $w_i$  and  $w'_i$  are primitive with continued fraction expansion  $[n_1, \dots, n_i]$  and  $[n_1, \dots, n_i + 1]$ .
2. It follows directly from the previous point knowing that  $w_r$  and  $\gamma$  are both primitive with the same slope.
  3. This is an induction on  $i$  using the basic fact that if  $\{a, b\}$  is a basis of  $\mathbb{F}_2$ , then so are  $\{a, ab\}$  and  $\{a, ba\}$ .
    - The previous argument immediately justifies that  $\{w_0, w'_0\}$  is a basis of  $\mathbb{F}_2$ .
    - Suppose that  $\{w_{i-1}, w'_{i-1}\}$  is a basis of  $\mathbb{F}_2$ , then, by the same argument as before, so is  $\{w_{i-1}, w_{i-1}w'_{i-1}\}$  and also, by induction  $\{w_{i-1}, w_{i-1}^{n_i-1}w'_{i-1}\}$ . Now, we deduce the same way that  $\{w_{i-1}^{n_i-1}w'_{i-1}, w_{i-1}^{n_i}w'_{i-1}\}$  is a basis of  $\mathbb{F}_2$  and thus that  $\{w_i, w'_i\}$  is a basis of  $\mathbb{F}_2$ .



□

*Remark 4.4.* Using the recursive definitions of  $w_i$  and  $w'_i$ , we draw the following equalities :

$$\text{For all } 2 \leq i \leq r \text{ and for } i = 1 \text{ if } n_1 \geq 1, \quad l_i = (n_i - 1)l_{i-1} + l'_{i-1} \quad \text{and} \quad l'_i = n_i l_{i-1} + l'_{i-1} \quad (4.1)$$

$$\text{For } i = 0 \text{ and for } i = 1 \text{ with } n_1 = 0, \quad l_i = 1 \text{ and } l'_i = 2 \quad (4.2)$$

$$\text{For all } 1 \leq i \leq r, \quad l'_i = l_i + l_{i-1} \quad (4.3)$$

$$(4.4)$$

We deduce the following inequalities :

$$\text{For all } 0 \leq i \leq r, \quad l_i < l'_i \quad \text{using (4.3) and } l_{i-1} > 0 \quad (4.5)$$

$$\text{For all } 1 \leq i \leq r \text{ and for } i = 0 \text{ if } n_1 \geq 1, \quad l_i < l_{i+1} \quad \text{using (4.1), } l'_{i-1} > l_{i-1} \text{ and } n_i \geq 1 \quad (4.6)$$

$$\text{For all } 2 \leq i \leq r \text{ and for } i = 1 \text{ if } n_1 \geq 1, \quad l'_i < 2l_i \quad \text{using (4.3) and } l_{i-1} < l_i \quad (4.7)$$

$$\text{For } i = 0 \text{ and for } i = 1 \text{ with } n_1 = 0, \quad l'_i = 2l_i \quad \text{using (4.2)} \quad (4.8)$$

$$\text{For all } 0 \leq i \leq r, \quad i \leq l_i \quad \text{by induction} \quad (4.9)$$

Then  $n_i l_{i-1} < l_i \leq (n_i + 1)l_{i-1}$  (using (4.1), (4.2) and  $l_{i-1} < l'_{i-1} \leq 2l_{i-1}$ ), thus :

$$\text{For all } 1 \leq i \leq r, \quad \boxed{n_i < \frac{l_i}{l_{i-1}} \leq n_i + 1}. \quad (4.10)$$

We also have  $l_i - l_{i-1} \geq l'_{i-1} - l_{i-1} = l_{i-2}$ , but  $l_{i-1} \leq (n_{i-1} + 1)l_{i-2}$ , so  $l_i - l_{i-1} \geq \frac{1}{n_{i-1} + 1}l_{i-1}$ , and then we deduce :

$$\text{For all } 2 \leq i \leq r, \quad \boxed{1 + \frac{1}{n_{i-1} + 1} \leq \frac{l_i}{l_{i-1}}} \quad (4.11)$$

## 4.2 Some useful lemmas

Recall that the notation  $|u|$  stands for the word length of the element  $u \in \mathbb{F}_2$ . For  $u$  an element in  $\mathbb{F}_2$  and  $k$  an integer smaller than  $|u|$ , we will denote by  $\widehat{u}^k$  its  $k$ -th cyclic permutation, that is, if  $u = s_1 \cdots s_{|u|}$ , the element  $\widehat{u}^k = s_{k+1} \cdots s_{|u|} s_1 \cdots s_k$ . We will also denote by  $\mathbf{p}_k(u)$  the prefix of length  $k$  of  $u$  and  $\mathbf{s}_k(u)$  the suffix of length  $k$  of  $u$ . We have  $u = \mathbf{p}_k(u)\mathbf{s}_{|u|-k}(u)$  and  $\widehat{u}^k = \mathbf{s}_{|u|-k}(u)\mathbf{p}_k(u)$ . Sometimes for the sake of simplicity we will no longer specify the integer  $k$  and write  $\mathbf{p}(u), \mathbf{s}(u), \widehat{u}$ . Finally, we will write  $\mathbf{sw}(u)$  to refer to a subword of  $u$ .

**Lemma 4.5.** *Let  $\gamma$  be a primitive element in  $\mathbb{F}_2$  and  $1 \leq i \leq r(\gamma)$ . In particular, up to conjugacy, the element  $\gamma$  can be written on the alphabet  $\{w_i(\gamma), w'_i(\gamma)\}$  (see Proposition 4.3).*

*Now take  $\widehat{w}_i(\gamma)$  any cyclic permutation of  $w_i(\gamma)$ . Then there exist  $\widehat{w}'_i(\gamma)$  a cyclic permutation of  $w'_i(\gamma)$  and  $\widehat{\gamma}$  a cyclic permutation of  $\gamma$  such that  $\widehat{\gamma}$  can be written on the alphabet  $\{w_i(\gamma), w'_i(\gamma)\}$ .*

Moreover, the element  $w_i(\widehat{\gamma})$  is either a prefix or a suffix of  $w'_i(\widehat{\gamma})$ .

In this case we say that the cyclic permutation  $w'_i(\widehat{\gamma})$  is adapted to  $w_i(\widehat{\gamma})$ .

*Proof.* The case  $i = 0$  is trivial because  $w_0 = a$  and then  $w_0$  has no non-trivial cyclic permutation. Let  $W$  be an element of  $\mathbb{F}_2$  that can be written on the alphabet  $\{w_i, w'_i\}$ , with  $i \geq 1$ . Then we can write  $W = u_1 \cdots u_r$ , with  $u_j \in \{w_i, w'_i\}$  for  $1 \leq j \leq r$ . Consider the  $k$ -th cyclic permutation of  $w_i$  :  
 $\widehat{w}_i^k = \mathfrak{s}_{l_i-k}(w_i)\mathfrak{p}_k(w_i)$ .

We make the proof by distinguishing two cases :

- **Case 1 :** If  $k \leq (n_i - 1)l_{i-1}$ .

Recall that, because  $i > 0$ , we have the following recursive formulae :

$$\begin{aligned} w_i &= w_{i-1}^{n_i-1} w'_{i-1} \\ w'_i &= w_{i-1}^{n_i} w'_{i-1} = w_{i-1}^{n_i-1} w_{i-1} w'_{i-1} \end{aligned}$$

Then in that case, we can say that  $\mathfrak{p}_k(w_i) = \mathfrak{p}_k(w'_i)$  and so  $\forall 1 \leq j, j' \leq r, \mathfrak{p}_k(u_j) = \mathfrak{p}_k(u_{j'})$ . Thus :

$$\begin{aligned} W &= u_1 u_2 \cdots u_r \\ &= \mathfrak{p}_k(u_1) \mathfrak{s}_{|u_1|-k}(u_1) \mathfrak{p}_k(u_2) \mathfrak{s}_{|u_2|-k}(u_2) \cdots \mathfrak{p}_k(u_r) \mathfrak{s}_{|u_r|-k}(u_r) \\ \widehat{W}^k &= \mathfrak{s}_{|u_1|-k}(u_1) \mathfrak{p}_k(u_2) \mathfrak{s}_{|u_2|-k}(u_2) \cdots \mathfrak{p}_k(u_r) \mathfrak{s}_{|u_r|-k}(u_r) \mathfrak{p}_k(u_1) \\ &= \mathfrak{s}_{|u_1|-k}(u_1) \mathfrak{p}_k(u_1) \mathfrak{s}_{|u_2|-k}(u_2) \cdots \mathfrak{p}_k(u_{r-1}) \mathfrak{s}_{|u_{r-1}|-k}(u_{r-1}) \mathfrak{p}_k(u_r) \\ &= \widehat{u}_1^k \cdots \widehat{u}_r^k \end{aligned}$$

We have proved that in that case,  $\widehat{W}^k$  can be written on the alphabet  $\{\widehat{w}_i^k, \widehat{w}'_i^k\}$ .

Now let us show that  $\widehat{w}_i^k$  is a suffix of  $\widehat{w}'_i^k$ . We have :

$$\begin{aligned} \widehat{w}_i^k &= \mathfrak{s}_{l_i-k}(w_i)\mathfrak{p}_k(w_i) \\ \widehat{w}'_i^k &= \mathfrak{s}_{l'_i-k}(w'_i)\mathfrak{p}_k(w'_i) = \mathfrak{s}_{l'_i-k}(w'_i)\mathfrak{p}_k(w_i) \end{aligned}$$

Since  $w_i$  is a suffix of  $w'_i$  and  $l'_i - k \geq l_i - k$ , it implies that  $\mathfrak{s}_{l_i-k}(w_i)$  is a suffix of  $\mathfrak{s}_{l'_i-k}(w'_i)$  and then that  $\widehat{w}_i^k$  is a suffix of  $\widehat{w}'_i^k$ .

- **Case 2 :** If  $k > (n_i - 1)l_{i-1}$ .

Let  $k' = k - (n_i - 1)l_{i-1}$ .

For all  $1 \leq j \leq r$ , there exists  $\varepsilon_j \in \{n_i - 1, n_i\}$  such that  $u_j = w_{i-1}^{\varepsilon_j} w'_{i-1}$ .  
Then  $u_j = w_{i-1}^{\varepsilon_j} \mathbf{p}_{k'}(w'_{i-1}) \mathbf{s}'_{l_{i-1}-k'}(w'_{i-1})$  and so :

$$\begin{aligned} W &= u_1 u_2 \cdots u_r \\ &= w_{i-1}^{\varepsilon_1} \mathbf{p}_{k'}(w'_{i-1}) \mathbf{s}'_{l_{i-1}-k'}(w'_{i-1}) w_{i-1}^{\varepsilon_2} \mathbf{p}_{k'}(w'_{i-1}) \mathbf{s}'_{l_{i-1}-k'}(w'_{i-1}) \cdots w_{i-1}^{\varepsilon_r} \mathbf{p}_{k'}(w'_{i-1}) \mathbf{s}'_{l_{i-1}-k'}(w'_{i-1}) \end{aligned}$$

Now let  $k_j = \varepsilon_j l_{i-1} + k'$ .

$$\text{Then } k_j = \begin{cases} k & \text{if } \varepsilon_j = n_i - 1 \\ k + l_{i-1} & \text{if } \varepsilon_j = n_i \end{cases} = \begin{cases} k & \text{if } u_j = w_i \\ k + l_{i-1} & \text{if } u_j = w'_i \end{cases}$$

Therefore  $\mathbf{s}'_{l_{i-1}-k'}(w'_{i-1}) w_{i-1}^{\varepsilon_j} \mathbf{p}_{k'}(w'_{i-1}) = \overset{\curvearrowright k_j}{u_j}$ . Finally :

$$\overset{\curvearrowright k_1}{W} = \overset{\curvearrowright k_2}{u_2} \cdots \overset{\curvearrowright k_r}{u_r} \overset{\curvearrowright k_1}{u_1}$$

We have proved that in that case,  $\overset{\curvearrowright k_1}{W}$  can be written on the alphabet  $\{\overset{\curvearrowright k}{w_i}, \overset{\curvearrowright k+l_{i-1}}{w'_{i-1}}\}$ .

Now let us show that  $\overset{\curvearrowright k}{w_i}$  is a prefix or a suffix of  $\overset{\curvearrowright k+l_{i-1}}{w'_{i-1}}$ . We have :

$$\begin{aligned} \overset{\curvearrowright k}{w_i} &= \mathbf{s}'_{l_{i-1}-k'}(w'_{i-1}) w_{i-1}^{n_i-1} \mathbf{p}_{k'}(w'_{i-1}) \\ \overset{\curvearrowright k+l_{i-1}}{w'_{i-1}} &= \mathbf{s}'_{l_{i-1}-k'}(w'_{i-1}) w_{i-1}^{n_i} \mathbf{p}_{k'}(w'_{i-1}) \end{aligned}$$

We first handle the case  $i = 1$ . In that case,  $w'_0 = ab, l'_0 = 2$ . There are three possibilities :  
either  $k' = 0$ , and then  $\overset{\curvearrowright k}{w_i}$  is a prefix of  $\overset{\curvearrowright k+l_{i-1}}{w'_{i-1}}$ , or  $k' = 2$ , and then  $\overset{\curvearrowright k}{w_i}$  is a suffix of  $\overset{\curvearrowright k+l_{i-1}}{w'_{i-1}}$ , or  
 $k' = 1$ , and then  $\overset{\curvearrowright k}{w_i} = ba^{n_i-1}a$  and  $\overset{\curvearrowright k+l_{i-1}}{w'_{i-1}} = ba^{n_i}a$  so  $\overset{\curvearrowright k}{w_i}$  is a prefix of  $\overset{\curvearrowright k+l_{i-1}}{w'_{i-1}}$ .

For the case  $i \geq 2$ , we can use the recursive formulae :

$$\begin{aligned} w_{i-1} &= w_{i-2}^{n_{i-1}-1} w'_{i-2} \\ w'_{i-1} &= w_{i-2}^{n_{i-1}} w'_{i-2} \end{aligned}$$

We distinguish two cases :

- If  $k' \leq (n_{i-1} - 1)l_{i-2}$  : then  $\mathbf{p}_{k'}(w'_{i-1})$  is a prefix of  $w_{i-1}$  so  $\overset{\curvearrowright k}{w_i}$  is a prefix of  $\overset{\curvearrowright k+l_{i-1}}{w'_{i-1}}$ .
- If  $k' > (n_{i-1} - 1)l_{i-2}$  : then  $l'_{i-1} - k' < l'_{i-1} - (n_{i-1} - 1)l_{i-2} = l_{i-2} + l'_{i-2}$ . So  $\mathbf{s}'_{l_{i-1}-k'}(w'_{i-1})$  is a suffix of  $w_{i-2} w'_{i-2}$ .
  - \* If  $n_{i-1} > 1$ ,  $w_{i-2} w'_{i-2}$  is a suffix of  $w_{i-1}$  so  $\mathbf{s}'_{l_{i-1}-k'}(w'_{i-1})$  is a suffix of  $w_{i-1}$  and so  $\overset{\curvearrowright k}{w_i}$  is a suffix of  $\overset{\curvearrowright k+l_{i-1}}{w'_{i-1}}$ .

\* If  $n_{i-1} = 1$ , we have  $w_{i-1} = w'_{i-2}$  and  $w'_{i-1} = w_{i-2}w'_{i-2}$ . If  $i > 2$ , we have  $w'_{i-1} = w_{i-2}w_{i-3}w_{i-2}$  and so a suffix of  $w_{i-2}w'_{i-2}$  is also a suffix of  $w'_{i-1}w_{i-1}$ , so  $s'_{i-1-k'}(w'_{i-1})$  is a suffix of  $w'_{i-1}w_{i-1}$  and so  $\widehat{w}_i^k$  is a suffix of  $\widehat{w}_i^{k+l_{i-1}}$ . If  $i = 2$ , we have  $w_{i-1} = ab$  and  $w'_{i-1} = aab$ , so  $w'_{i-1}w_{i-1} = aabab$ . Moreover  $w_{i-2}w'_{i-2} = aab$  so

$$\begin{aligned} \widehat{w}_i^k &= s'_{i-1-k'}(aab)(ab)^{n_i-1}p_{k'}(aab) \\ \widehat{w}_i^{k+l_{i-1}} &= s'_{i-1-k'}(aab)(ab)^{n_i}p_{k'}(aab) \end{aligned}$$

And we notice that again in that case,  $\widehat{w}_i^k$  is either a prefix or a suffix of  $\widehat{w}_i^{k+l_{i-1}}$ .

□

The following Proposition is the most important of this Chapter. It says that subwords of some specific lengths ( $l_i(\gamma)$ ) of primitive elements are themselves primitive, after a possible change of letter.

**Proposition 4.6.** *Let  $\gamma$  be a cyclically reduced primitive element of  $\mathbb{F}_2$  and  $u$  any subword of  $\gamma$  (or of a cyclic permutation of  $\gamma$ ) of length  $l_i(\gamma)$ , for  $0 \leq i \leq r(\gamma)$ . Then, after possibly changing its last letter,  $u$  is in fact a cyclic permutation of  $w_i(\gamma)$ .*

*Proof.* For the sake of simplicity, we omit the dependence on  $\gamma$  in the notations in the proof.

First of all, we deal separately with the cases  $i = 0$  and  $i = 1$ .

- If  $i = 0$ , then  $u = a$  or  $u = b$ , and thus it is trivial.
- If  $i = 1$ , then  $u = a^{n_1+1}$  or  $u = a^k b a^{n_1-k}$ , with  $0 \leq k \leq n_1$ . In the first case, after changing the last letter  $a$  into  $b$ , we obtain  $u = a^{n_1} b = w_1$ . In the second case, no change is needed.

From now on, we suppose that  $i \geq 2$ . In that case, the recursive formulae  $w_i = w_{i-1}^{n_i-1} w'_{i-1}$  and  $w'_i = w_{i-1}^{n_i} w'_{i-1}$  apply.

The word  $\gamma$  can be written on the alphabet  $\{w_i, w'_i\}$ , and  $l'_i \geq l_i$  so the subword  $u$  of  $\gamma$  shall take one of the following forms :  $s(w_i)p(w_i)$ ,  $s(w_i)p(w'_i)$ ,  $s(w'_i)p(w_i)$ ,  $s(w'_i)p(w'_i)$  or  $sw(w'_i)$ .

Furthermore, since  $w'_i = w_{i-1}w_i$  and  $|s(w'_i)| \leq l_i$ , we deduce that  $s(w'_i) = s(w_i)$ . Thus,  $u$  can actually be reduced to one of the following three forms :

1.  $u = s(w_i)p(w_i)$
2.  $u = sw(w'_i)$
3.  $u = s(w_i)p(w'_i)$

We deal with each case separately.

1. The case 1 is actually immediate because  $|\mathbf{s}(w_i)\mathbf{p}(w_i)| = l_i$ , so  $|\mathbf{p}(w_i)\mathbf{s}(w_i)| = l_i$ , which requires  $\mathbf{p}(w_i)\mathbf{s}(w_i) = w_i$  and then  $u = \mathbf{s}(w_i)\mathbf{p}(w_i)$  is a cyclic permutation of  $w_i$ .
2. Now let us deal with the case 2. Recall  $w'_i = w_{i-1}^{n_i} w'_{i-1} = w_{i-1} w_{i-1}^{n_i-1} w'_{i-1}$  (because  $n_i \geq 1$ ). Then a subword of length  $l_i$  of  $w'_i$  must be of the form :  $u = \mathbf{sw}(w'_i) = \mathbf{s}(w_{i-1})w_{i-1}^{n_i-1}\mathbf{p}(w'_{i-1})$ . Therefore, up to cyclic permutation we have  $\widehat{u} = w_{i-1}^{n_i-1}\mathbf{p}(w'_{i-1})\mathbf{s}(w_{i-1})$ , with  $|\mathbf{p}(w'_{i-1})\mathbf{s}(w_{i-1})| = l'_{i-1}$ . Moreover, for  $i \geq 2$ , we have  $\mathbf{s}(w_{i-1}) = \mathbf{s}(w'_{i-1})$  and then  $\mathbf{p}(w'_{i-1})\mathbf{s}(w_{i-1}) = \mathbf{p}(w'_{i-1})\mathbf{s}(w'_{i-1}) = w'_{i-1}$ . Thus  $\widehat{u} = w_{i-1}^{n_i-1}\mathbf{p}(w'_{i-1})\mathbf{s}(w_{i-1}) = w_{i-1}^{n_i-1}w'_{i-1} = w_i$ .
3. For the case 3, we use a two-step induction on  $i \geq 0$ . More precisely, we will show by induction on  $i \geq 0$ , that if  $u$  is a subword of  $\gamma$  of the form  $u = \mathbf{s}(w_i)\mathbf{p}(w'_i)$  with  $|u| = l_i$ , then, after possibly changing its last letter, that is after possibly changing the last letter of  $\mathbf{p}(w'_i)$ , we obtain  $\widehat{\mathbf{p}}(w'_i)\mathbf{s}(w_i) = w_i$  or  $\widehat{\mathbf{p}}(w'_i)\mathbf{s}(w_i) = w_{i-1}^{n_i} w_{i-2}$  (the latter case can only occur if  $i \geq 2$ ), with  $\widehat{\mathbf{p}}(w'_i)$  the word obtained from  $\mathbf{p}(w'_i)$  after the change of letter. Thus, we deduce that after possibly changing its last letter,  $u$  is actually a cyclic permutation of  $w_i$ . In the following, the notation  $\widehat{\mathbf{p}}(w)$  stands for the word obtained from  $\mathbf{p}(w)$  by changing its last letter.

### Initial cases :

The trivial case  $i = 0$  has already been mentioned at the beginning of the proof.

Suppose  $i = 1$ . Then  $\mathbf{s}(w_1) = \mathbf{s}(a^{n_1}b)$ . If  $|\mathbf{s}(w_1)| \geq 1$ , then there exists an integer  $k$  such that  $\mathbf{s}(w_1) = a^k b$  and  $\mathbf{p}(w'_1) = a^{n_1-k}$  and so  $\mathbf{p}(w'_1)\mathbf{s}(w_1) = a^{n_1}b = w_1$ . If  $|\mathbf{s}(w_1)| = 0$ , then  $\mathbf{p}(w'_1)\mathbf{s}(w_1) = \mathbf{p}(w'_1) = a^{n_1+1}$ . So after possibly changing the last letter of  $\mathbf{p}(w'_1)$  into  $b$ , we have  $\widehat{\mathbf{p}}(w'_1)\mathbf{s}(w_1) = a^{n_1}b = w_1$ .

**Induction step :** We now fix  $i \geq 2$

Let  $k = |\mathbf{p}(w'_i)|$ . Let us distinguish two cases :

- (a) If  $k \leq (n_i - 1)l_{i-1} (= l_i - l'_{i-1})$  : then  $\mathbf{p}(w'_i) = \mathbf{p}(w_i)$ , so as before in the proof we have  $\mathbf{p}(w'_i)\mathbf{s}(w_i) = \mathbf{p}(w_i)\mathbf{s}(w_i) = w_i$  because  $|\mathbf{p}(w_i)\mathbf{s}(w_i)| = l_i$ . Thus  $\boxed{\mathbf{p}(w'_i)\mathbf{s}(w_i) = w_i}$
- (b) If  $k \geq (n_i - 1)l_{i-1} (= l_i - l'_{i-1})$ , then  $\mathbf{p}(w'_i) = w_{i-1}^{n_i-1}\mathbf{p}(w_{i-1}w'_{i-1})$  on one hand and  $|\mathbf{s}(w_i)| \leq l'_{i-1}$  so  $\mathbf{s}(w_i) = \mathbf{s}(w'_{i-1})$  on the other hand. Thus  $\boxed{\mathbf{p}(w'_i)\mathbf{s}(w_i) = w_{i-1}^{n_i-1}\mathbf{p}(w_{i-1}w'_{i-1})\mathbf{s}(w'_{i-1})}$ .

We now need to understand the word  $\mathbf{p}(w_{i-1}w'_{i-1})\mathbf{s}(w'_{i-1})$ , with  $|\mathbf{p}(w_{i-1}w'_{i-1})\mathbf{s}(w'_{i-1})| = l'_{i-1}$ .

- i. If  $|\mathbf{p}(w_{i-1}w'_{i-1})| \leq (n_{i-1} - 1)l_{i-2}$ , then  $\mathbf{p}(w_{i-1}w'_{i-1}) = \mathbf{p}(w_{i-2}^{n_{i-1}-1}) = \mathbf{p}(w'_{i-1})$ , so  $\frac{\mathbf{p}(w_{i-1}w'_{i-1})\mathbf{s}(w'_{i-1})}{\mathbf{p}(w'_{i-1})\mathbf{s}(w'_{i-1})} = w'_{i-1}$  because  $|\mathbf{p}(w_{i-1}w'_{i-1})\mathbf{s}(w'_{i-1})| = l'_{i-1}$ . In

this case we obtain  $\boxed{\mathbf{p}(w_{i-1}w'_{i-1})\mathbf{s}(w'_{i-1}) = w'_{i-1}}$ .

- ii. If  $(n_{i-1} - 1)l_{i-2} \leq |\mathbf{p}(w_{i-1}w'_{i-1})| \leq n_{i-1}l_{i-2}$ , then  $\mathbf{p}(w_{i-1}w'_{i-1}) = w_{i-2}^{n_{i-1}-1}\mathbf{p}(w'_{i-2})$  on one hand, and  $l'_{i-2} \leq |\mathbf{s}(w'_{i-1})| \leq l'_{i-2} + l_{i-2}$  so  $\mathbf{s}(w'_{i-1}) = \mathbf{s}(w_{i-2})w'_{i-2}$  on the other hand. Thus  $\mathbf{p}(w_{i-1}w'_{i-1})\mathbf{s}(w'_{i-1}) = w_{i-2}^{n_{i-1}-1}\mathbf{p}(w'_{i-2})\mathbf{s}(w_{i-2})w'_{i-2}$ , with  $|\mathbf{p}(w'_{i-2})\mathbf{s}(w_{i-2})| = l_{i-2}$ . Here we use our induction hypothesis :

- If, after possibly changing the last letter of  $\mathbf{p}(w'_{i-2})$ , we have  $\hat{\mathbf{p}}(w'_{i-2})\mathbf{s}(w_{i-2}) = w_{i-2}$ , then, after possibly changing the last letter of  $\mathbf{p}(w_{i-1}w'_{i-1})$ ,

$$\hat{\mathbf{p}}(w_{i-1}w'_{i-1})\mathbf{s}(w'_{i-1}) = w_{i-2}^{n_{i-1}-1}\hat{\mathbf{p}}(w'_{i-2})\mathbf{s}(w_{i-2})w'_{i-2} = w_{i-2}^{n_{i-1}-1}w_{i-2}w'_{i-2} = w'_{i-1}.$$

Thus, as in the previous case,  $\boxed{\hat{\mathbf{p}}(w_{i-1}w'_{i-1})\mathbf{s}(w'_{i-1}) = w'_{i-1}}$ .

- If, after possibly changing the last letter of  $\mathbf{p}(w'_{i-2})$ , we have  $\hat{\mathbf{p}}(w'_{i-2})\mathbf{s}(w_{i-2}) = w_{i-3}^{n_{i-2}}w_{i-4}$  (recall that this case can only occur if  $i \geq 4$ , as stated at the beginning of the induction), then, after possibly changing the last letter of  $\mathbf{p}(w_{i-1}w'_{i-1})$ ,

$$\begin{aligned} \hat{\mathbf{p}}(w_{i-1}w'_{i-1})\mathbf{s}(w'_{i-1}) &= w_{i-2}^{n_{i-1}-1}\hat{\mathbf{p}}(w'_{i-2})\mathbf{s}(w_{i-2})w'_{i-2} = w_{i-2}^{n_{i-1}-1}w_{i-3}^{n_{i-2}}w_{i-4}w'_{i-2} \\ &= w_{i-2}^{n_{i-1}-1}w_{i-3}^{n_{i-2}}w_{i-4}w_{i-3}w_{i-2} = w_{i-2}^{n_{i-1}-1}w_{i-3}^{n_{i-2}}w'_{i-3}w_{i-2} \\ &= w_{i-2}^{n_{i-1}-1}w'_{i-2}w_{i-2} = w_{i-1}w_{i-2}. \end{aligned}$$

Thus, in that case, we obtain  $\boxed{\hat{\mathbf{p}}(w_{i-1}w'_{i-1})\mathbf{s}(w'_{i-1}) = w_{i-1}w_{i-2}}$ .

- iii. If  $n_{i-1}l_{i-2} \leq |\mathbf{p}(w_{i-1}w'_{i-1})| \leq l'_{i-1}$ , then  $\mathbf{p}(w_{i-1}w'_{i-1}) = w_{i-2}^{n_{i-1}-1}\mathbf{p}(w'_{i-2}w_{i-2})$  on one hand and  $|\mathbf{s}(w'_{i-1})| \leq l'_{i-2}$  so  $\mathbf{s}(w'_{i-1}) = \mathbf{s}(w'_{i-2})$  on the other hand.

Thus  $\boxed{\mathbf{p}(w_{i-1}w'_{i-1})\mathbf{s}(w'_{i-1}) = w_{i-2}^{n_{i-1}-1}\mathbf{p}(w'_{i-2}w_{i-2})\mathbf{s}(w'_{i-2})}$  with  $|\mathbf{p}(w'_{i-2}w_{i-2})\mathbf{s}(w'_{i-2})| = l'_{i-2} + l_{i-2}$ . We still need to understand  $\mathbf{p}(w'_{i-2}w_{i-2})\mathbf{s}(w'_{i-2})$  with  $|\mathbf{p}(w'_{i-2}w_{i-2})\mathbf{s}(w'_{i-2})| = l'_{i-2} + l_{i-2}$ .

- If  $|\mathbf{p}(w'_{i-2}w_{i-2})| \geq l'_{i-2}$ , then  $\mathbf{p}(w'_{i-2}w_{i-2}) = w'_{i-2}\mathbf{p}(w_{i-2})$  on one hand and  $|\mathbf{s}(w'_{i-2})| \leq l_{i-2}$  so  $\mathbf{s}(w'_{i-2}) = \mathbf{s}(w_{i-2})$ . Now we can compute  $\mathbf{p}(w'_{i-2}w_{i-2})\mathbf{s}(w'_{i-2}) = w'_{i-2}\mathbf{p}(w_{i-2})\mathbf{s}(w_{i-2}) = w'_{i-2}w_{i-2}$  and the last equality stands because

$$|\mathbf{p}(w_{i-2})\mathbf{s}(w_{i-2})| = l_{i-2}. \text{ Thus } \boxed{\mathbf{p}(w'_{i-2}w_{i-2})\mathbf{s}(w'_{i-2}) = w'_{i-2}w_{i-2}}.$$

- If  $|\mathbf{p}(w'_{i-2}w_{i-2})| \leq l'_{i-2}$ , then we have  $l_{i-2} \leq |\mathbf{p}(w'_{i-2}w_{i-2})| \leq l'_{i-2}$  because  $|\mathbf{s}(w'_{i-2})| \leq l'_{i-2}$ . We also deduce that  $l_{i-2} \leq |\mathbf{s}(w'_{i-2})| \leq l'_{i-2}$ .

If  $i = 2$ , then  $l_{i-2} = l_0 = 1, l'_{i-2} = l'_0 = 2, w'_0w_0 = aba$  and  $w'_0 = ab$ . Then  $\mathbf{p}(w'_0w_0)\mathbf{s}(w'_0) = aab$  or  $\mathbf{p}(w'_0w_0)\mathbf{s}(w'_0) = abb$ . So, after possibly changing the last letter of  $\mathbf{p}(w'_0w_0)$ , we have  $\hat{\mathbf{p}}(w'_0w_0)\mathbf{s}(w'_0) = aab = w_0w'_0$ .

If  $i > 2$ , we can write  $w'_{i-2} = w_{i-3}^{n_{i-2}}w'_{i-3}$  and so  $\mathbf{p}(w'_{i-2}w_{i-2}) = w_{i-3}^{n_{i-2}}\mathbf{p}(w'_{i-3})$  and  $\mathbf{s}(w'_{i-2}) = \mathbf{s}(w_{i-3})w_{i-2}$ . Thus  $\mathbf{p}(w'_{i-2}w_{i-2})\mathbf{s}(w'_{i-2}) = w_{i-3}^{n_{i-2}}\mathbf{p}(w'_{i-3})\mathbf{s}(w_{i-3})w_{i-2}$  with  $|\mathbf{p}(w'_{i-3})\mathbf{s}(w_{i-3})| = l'_{i-3}$ . But, as seen in the case 2, for  $i > 3$ ,  $\mathbf{p}(w'_{i-3})\mathbf{s}(w_{i-3}) = w'_{i-3}$ .

Then we compute  $\mathbf{p}(w'_{i-2}w_{i-2})\mathbf{s}(w'_{i-2}) = w_{i-3}^{n_{i-2}}\mathbf{p}(w'_{i-3})\mathbf{s}(w_{i-3})w_{i-2} = w_{i-3}^{n_{i-2}}w'_{i-3}w_{i-2} = w'_{i-2}w_{i-2}$ .

For  $i = 3$ , recall that  $w_{i-3} = w_0 = a$  and  $w'_{i-3} = w'_0 = ab$ . If  $|\mathbf{s}(w_0)| = 0$ , then  $\mathbf{p}(w'_{i-3})\mathbf{s}(w_{i-3}) = \mathbf{p}(w'_0)\mathbf{s}(w_0) = \mathbf{p}(w'_0) = w'_0$ . Thus  $\mathbf{p}(w'_{i-2}w_{i-2})\mathbf{s}(w'_{i-2}) = w_{i-3}^{n_{i-2}}\mathbf{p}(w'_{i-3})\mathbf{s}(w_{i-3})w_{i-2} = w_{i-3}^{n_{i-2}}w'_{i-3}w_{i-2} = w'_{i-2}w_{i-2}$ . However, if  $|\mathbf{s}(w_0)| = 1$ , then  $\mathbf{p}(w'_{i-3})\mathbf{s}(w_{i-3}) = \mathbf{p}(w'_0)\mathbf{s}(w_0) = \mathbf{p}(w'_0)a = a^2$ , and then, after changing the last letter of  $\mathbf{p}(w'_0)$  from  $a$  to  $b$ , we obtain  $\hat{\mathbf{p}}(w'_0)\mathbf{s}(w_0) = ba$ . Thus, let us now compute  $\hat{\mathbf{p}}(w'_{i-2}w_{i-2})\mathbf{s}(w'_{i-2})$  :

$$\hat{\mathbf{p}}(w'_{i-2}w_{i-2})\mathbf{s}(w'_{i-2}) = w_{i-3}^{n_{i-2}}\hat{\mathbf{p}}(w'_{i-3})\mathbf{s}(w_{i-3})w_{i-2} = w_{i-3}^{n_{i-2}}baw_{i-2} = a^{n_1}baw_1 = w_1w'_1.$$

Thus, we conclude from those different cases that, after possibly changing the last letter of  $\mathbf{p}(w'_{i-2}w_{i-2})$ , we have either  $\hat{\mathbf{p}}(w'_{i-2}w_{i-2})\mathbf{s}(w'_{i-2}) = w'_{i-2}w_{i-2}$ , or  $\hat{\mathbf{p}}(w'_{i-2}w_{i-2})\mathbf{s}(w'_{i-2}) = w_{i-2}w'_{i-2}$ . We can now compute  $\hat{\mathbf{p}}(w_{i-1}w'_{i-1})\mathbf{s}(w'_{i-1})$  :

- If  $\hat{\mathbf{p}}(w'_{i-2}w_{i-2})\mathbf{s}(w'_{i-2}) = w'_{i-2}w_{i-2}$ , then

$$\hat{\mathbf{p}}(w_{i-1}w'_{i-1})\mathbf{s}(w'_{i-1}) = w_{i-2}^{n_{i-1}-1}\hat{\mathbf{p}}(w'_{i-2}w_{i-2})\mathbf{s}(w'_{i-2}) = w_{i-2}^{n_{i-1}-1}w'_{i-2}w_{i-2} = w_{i-1}w_{i-2}.$$

- If  $\hat{\mathbf{p}}(w'_{i-2}w_{i-2})\mathbf{s}(w'_{i-2}) = w_{i-2}w'_{i-2}$ , then

$$\hat{\mathbf{p}}(w_{i-1}w'_{i-1})\mathbf{s}(w'_{i-1}) = w_{i-2}^{n_{i-1}-1}\hat{\mathbf{p}}(w'_{i-2}w_{i-2})\mathbf{s}(w'_{i-2}) = w_{i-2}^{n_{i-1}-1}w_{i-2}w'_{i-2} = w_{i-2}^{n_{i-1}}w'_{i-2} = w'_{i-1}.$$

Thus, we showed that after possibly changing the last letter of  $\mathbf{p}(w_{i-1}w'_{i-1})$ , we have  $\hat{\mathbf{p}}(w_{i-1}w'_{i-1})\mathbf{s}(w'_{i-1}) = w'_{i-1}$  or  $\hat{\mathbf{p}}(w_{i-1}w'_{i-1})\mathbf{s}(w'_{i-1}) = w_{i-1}w_{i-2}$ . We are now ready to compute  $\hat{\mathbf{p}}(w'_i)\mathbf{s}(w_i)$  :

- If  $\hat{\mathbf{p}}(w_{i-1}w'_{i-1})\mathbf{s}(w'_{i-1}) = w'_{i-1}$ , then

$$\hat{\mathbf{p}}(w'_i)\mathbf{s}(w_i) = w_{i-1}^{n_i-1}\hat{\mathbf{p}}(w_{i-1}w'_{i-1})\mathbf{s}(w'_{i-1}) = w_{i-1}^{n_i-1}w'_{i-1} = w_i.$$

- If  $\hat{\mathbf{p}}(w_{i-1}w'_{i-1})\mathbf{s}(w'_{i-1}) = w_{i-1}w_{i-2}$ , then

$$\hat{\mathbf{p}}(w'_i)\mathbf{s}(w_i) = w_{i-1}^{n_i-1}\hat{\mathbf{p}}(w_{i-1}w'_{i-1})\mathbf{s}(w'_{i-1}) = w_{i-1}^{n_i-1}w_{i-1}w_{i-2} = w_{i-1}^{n_i}w_{i-2}.$$

Thus, we have proven what we announced for the case 3.

Hence the lemma is proved.  $\square$

We end this chapter with a short Lemma which "counts" the number of occurrences of  $w_i(\gamma)$  in a subword  $u$  of  $\gamma$ .

**Lemma 4.7.** *Let  $\alpha > 4$ . Let  $\gamma$  be a primitive element of  $\mathbb{F}_2$  and  $u$  any subword of  $\gamma$  (or of a cyclic permutation of  $\gamma$ ). Let  $i \in \{1, \dots, r(\gamma)\}$  and suppose that  $|u| \geq \alpha l_i(\gamma)$ . Let  $w_i(\gamma)$  be any cyclic permutation of  $w_i(\gamma)$  and  $w'_i(\gamma)$  a cyclic permutation of  $w'_i(\gamma)$  adapted to  $w_i(\gamma)$  (see lemma 4.5). Then, there is at least  $\frac{\alpha-4}{2}$  occurrences of  $w_i(\gamma)$  and  $w'_i(\gamma)$  in  $u$ .*

*Proof.* Recall that  $l_i(\gamma) \leq l'_i(\gamma) \leq 2l_i(\gamma)$ . Then we have the inequality  $|u| \geq \frac{\alpha}{2}l'_i(\gamma)$ .

The element  $u$  is a subword of  $\gamma$  and, by the lemme 4.5,  $\gamma$  can be written on the alphabet  $\{\widehat{w}_i(\gamma), \widehat{w}'_i(\gamma)\}$  so  $u$  can be written in the following way :  $u = \mathbf{p}(u)u_1 \cdots u_r \mathbf{s}(u)$ , with  $u_k \in \{\widehat{w}_i(\gamma), \widehat{w}'_i(\gamma)\}$  for  $1 \leq k \leq r$  and  $\mathbf{p}(u)$  and  $\mathbf{s}(u)$  being respectively a prefix and a suffix of  $u$  such that  $|\mathbf{p}(u)|, |\mathbf{s}(u)| \leq |\widehat{w}'_i(\gamma)| = l'_i(\gamma)$ . Thus  $|u| - |\mathbf{p}(u)| - |\mathbf{s}(u)| \geq \frac{\alpha}{2}l'_i(\gamma) - 2l'_i(\gamma) = \frac{\alpha-4}{2}l'_i(\gamma)$ . Furthermore  $|u| - |\mathbf{p}(u)| - |\mathbf{s}(u)| = \sum_{k=1}^r |u_k| \leq rl'_i(\gamma)$  because  $|u_k| \leq l'_i(\gamma)$ . We deduce  $r \geq \frac{\alpha-4}{2}$ , hence the lemma 4.7. □





# Chapter 5

## Local uniform quasi-geodesicity

### 5.1 A first example of a uniform quasi-geodesicity setting

In this section, we are going to study a uniform quasi-geodesicity setting in the space  $X$ . The space  $X$  is supposed to be  $\delta$ -hyperbolic, geodesic and proper (proper means that closed balls are compact). When we are given two isometries  $A$  and  $B$ , we can consider the set  $\mathcal{W}(A, B)$  of (finite) words on  $A$  and  $B$ . For  $G \in \mathcal{W}(A, B)$ , we denote by  $|G|$  its word length, that is the minimal number of letters ( $A$  and  $B$ ) needed to write  $G$ . We also consider  $\mathcal{H}(A, B) = \{A, B\}^{\mathbb{Z}}$  the set of bi-infinite words on  $A$  and  $B$ , that is,  $H = (H_n)_{n \in \mathbb{Z}} \in \mathcal{H}(A, B)$  if and only if for all  $n \in \mathbb{Z}$ ,  $H_n \in \{A, B\}$ . When we have a bi-infinite word  $H = (H_n)_{n \in \mathbb{Z}} \in \mathcal{H}(A, B)$ , we associate to it a bi-infinite sequence of finite words  $G = (G_n)_{n \in \mathbb{Z}}$  in the following way :

$$G_n = \begin{cases} H_0 H_1 \cdots H_{n-1} & \text{for } n > 0 \\ I_d & \text{for } n = 0 \\ H_{-1}^{-1} \cdots H_n^{-1} & \text{for } n < 0 \end{cases}$$

Hence  $G_n \in \mathcal{W}(A, B)$  for all  $n \geq 0$  and  $G_n \in \mathcal{W}(A^{-1}, B^{-1})$  for all  $n \leq 0$ . Moreover, the word length of  $G_n$  is  $|G_n| = |n|$  for all  $n \in \mathbb{Z}$  and the following recursive formula holds for all  $n \in \mathbb{Z}$  :  $G_{n+1} = G_n H_n$ . We denote by  $\mathcal{G}(A, B)$  the set of bi-infinite sequences of finite words associate to bi-infinite words in  $\mathcal{H}(A, B)$ .

In this section, we want to study a particular class of bi-infinite words  $H = (H_n)_{n \in \mathbb{Z}}$  and their associate bi-infinite sequences of words  $G = (G_n)_{n \in \mathbb{Z}}$ . Let us fix an integer  $N \geq 1$  and define  $\mathcal{H}_N(A, B)$  to be the subset of  $\mathcal{H}(A, B)$  consisting of the bi-infinite words  $H = (H_n)_{n \in \mathbb{Z}}$  which satisfy the following condition :

If  $n_1 < n_2$  are two integers in  $\mathbb{Z}$  such that  $H_{n_1} = H_{n_2} = B$  and for all  $n_1 < n < n_2$ ,  $H_n = A$ , then  $n_2 - n_1 - 1 \geq N$ .

Thus the bi-infinite words in  $\mathcal{H}_N(A, B)$  are precisely those for which the appearances of  $B$  are isolated and the powers of  $A$  are always greater than  $N$ . We denote by  $\mathcal{G}_N(A, B)$  the set of bi-infinite sequences  $G = (G_n)_{n \in \mathbb{Z}} \in \mathcal{G}(A, B)$  associate to bi-infinite words in  $\mathcal{H}_N(A, B)$ .

Fix  $o$  a basepoint in  $X$ . Starting from a bi-infinite word  $H = (H_n)_{n \in \mathbb{Z}} \in \mathcal{H}(A, B)$  and its associate bi-infinite sequence  $G = (G_n)_{n \in \mathbb{Z}} \in \mathcal{G}(A, B)$ , we define the sequence of points in  $X$  :  $x_n = G_n o, \forall n \in \mathbb{Z}$ . The goal of this section is to study the uniform quasi-geodesicity of sequences of points defined by the elements of  $\mathcal{G}_N(A, B)$ , that is the existence of two reals  $\lambda > 0$  and  $k \geq 0$  such that for all  $n, m \in \mathbb{Z}$ , we have :  $\frac{1}{\lambda}|n - m| - k \leq d(x_n, x_m) \leq \lambda|n - m| + k$ . The sequence  $(x_n)_{n \in \mathbb{Z}}$  is a  $(\lambda, k, L)$ -local-quasi-geodesic if we have  $\frac{1}{\lambda}|n - m| - k \leq d(x_n, x_m) \leq \lambda|n - m| + k$  whenever  $|n - m| \leq L$ . Precisely we prove the following lemma :

**Lemma 5.1.** *Let  $X$  be a  $\delta$ -hyperbolic space, geodesic and proper, and  $o \in X$  any basepoint. Pick  $A$  and  $B$  two hyperbolic isometries of  $X$  and suppose that  $B(A^+) \neq A^-$ . Then, there exists  $\lambda > 0, k \geq 0$  and  $N \in \mathbb{N}^*$ , such that  $\forall G = (G_n)_{n \in \mathbb{Z}} \in \mathcal{G}_N(A, B)$ , the sequence of points  $x_n = G_n o$  is a  $(\lambda, k)$ -quasi-geodesic.*

*Proof.* • **Step 1 : Quasi-isometry on a period**

The goal is at first to show that there exists two constants  $\lambda > 0$  and  $k \geq 0$ , only depending on  $\delta, A, B$  and  $o$ , such that the following inequality is satisfied :

$$\frac{1}{\lambda}|A^n B A^m| - k \leq d(A^n B A^m o, o) \quad \text{for all } n, m \geq 0 \quad (5.1)$$

By hypothesis, the two points at infinity  $B(A^+)$  and  $A^-$  are distinct, so we can consider a geodesic, called  $\Lambda$ , with endpoints  $B(A^+)$  and  $A^-$ . Such a geodesic exists because the space  $X$  is supposed to be proper. Now consider  $p$  a projection map on  $\Lambda$ , that is  $p : X \rightarrow \Lambda$  satisfying  $\forall x \in X, d(x, p(x)) = d(x, \Lambda) = \inf_{y \in \Lambda} d(x, y)$  (such a map exists but is not necessarily unique). Since  $(A^{-n} o)_{n \in \mathbb{N}}$  is a (half) quasi-geodesic with endpoint  $A^-$  and  $\Lambda$  is a geodesic with  $A^-$  as one of its endpoints, we have, by stability of quasi-geodesics in  $\delta$  hyperbolic spaces, the existence of a constant  $K_1 > 0$  (only depending on  $\delta, A, B$  and  $o$ ) such that  $\{A^{-n} o\}_{n \in \mathbb{N}}$  and the half geodesic  $[p(o), A^-)$  remain in the  $K_1$ -neighborhood of each other. We deduce the following inequality :

$$d(A^{-n} o, p(A^{-n} o)) \leq K_1, \text{ for all } n \in \mathbb{N} \quad (5.2)$$

With the same argument, namely that the (half) geodesic  $(B A^m o)_{m \in \mathbb{N}}$  and  $\Lambda$  share the same endpoint  $B(A^+)$ , we deduce the existence of constant  $K_2 > 0$  (only depending on  $\delta, A, B$  and  $o$ ) such that

$$d(B A^m o, p(B A^m o)) \leq K_2, \text{ for all } m \in \mathbb{N} \quad (5.3)$$

Then we can draw the following inequalities :

$$\begin{aligned} d(A^n B A^m o, o) &= d(B A^m o, A^{-n} o) \text{ because } A^n \text{ is an isometry} \\ &\geq d(p(B A^m o), p(A^{-n} o)) - d(p(B A^m o), B A^m o) - d(p(A^{-n} o), A^{-n} o) \\ &\geq d(p(B A^m o), p(A^{-n} o)) - K_1 - K_2 \text{ by inequalities 5.2 and 5.3} \end{aligned}$$

But since  $A^{-n} o \xrightarrow{n \rightarrow \infty} A^-$ , we also have  $p(A^{-n} o) \xrightarrow{n \rightarrow \infty} A^-$ , and in the same way, since  $B A^m o \xrightarrow{m \rightarrow \infty} B(A^+)$ , we deduce  $p(B A^m o) \xrightarrow{m \rightarrow \infty} B(A^+)$ . Then, for  $n$  and  $m$  sufficiently large,  $p(A^{-n} o)$  belongs to  $[p(o), A^-) \cap [p(B o), A^-)$  and  $p(B A^m o)$  belongs to  $[p(o), B(A^+)) \cap [p(B o), B(A^+))$ . This

shows that for  $n$  and  $m$  sufficiently large, the four points  $p(A^{-n}o), p(BA^mo), p(Bo)$  and  $p(o)$  are aligned in one of the two following orders on the geodesic  $\Lambda : p(A^{-n}o), p(o), p(Bo), p(BA^mo)$  or  $p(A^{-n}o), p(Bo), p(o), p(BA^mo)$ . In the first case

$$d(p(A^{-n}o), p(BA^mo)) = d(p(A^{-n}o), p(o)) + d(p(o), p(Bo)) + d(p(Bo), p(BA^mo))$$

and in the second one :

$$d(p(A^{-n}o), p(BA^mo)) = d(p(A^{-n}o), p(o)) - d(p(o), p(Bo)) + d(p(Bo), p(BA^mo))$$

so, in every case, for  $n$  and  $m$  sufficiently large :

$$d(p(A^{-n}o), p(BA^mo)) \geq d(p(A^{-n}o), p(o)) - d(p(o), p(Bo)) + d(p(Bo), p(BA^mo)).$$

On an other hand,

$$\begin{aligned} d(p(A^{-n}o), p(o)) &\geq d(A^{-n}o, o) - d(A^{-n}o, p(A^{-n}o)) - d(p(o), o) \\ &\geq d(A^{-n}o, o) - K_1 - d(p(o), o) \text{ by inequality 5.2} \end{aligned}$$

and similarly :

$$d(p(BA^mo), p(Bo)) \geq d(BA^mo, Bo) - K_2 - d(p(Bo), Bo) \text{ by inequality 5.3.}$$

We can now finish our sequence of inequalities :

$$\begin{aligned} d(A^n BA^mo, o) &\geq d(p(BA^mo), p(A^{-n}o)) - K_1 - K_2 \\ &\geq d(p(A^{-n}o), p(o)) - d(p(o), p(Bo)) + d(p(Bo), p(BA^mo)) - K_1 - K_2 \\ &\geq d(A^{-n}o, o) - d(p(o), o) + d(BA^mo, Bo) - d(p(Bo), Bo) - d(p(o), p(Bo)) - 2K_1 - 2K_2 \\ &= d(A^n o, o) + d(A^m o, o) - d(p(o), o) - d(p(Bo), Bo) - d(p(o), p(Bo)) - 2K_1 - 2K_2 \\ &\geq (n+m)l_S(A) - d(p(o), o) - d(p(Bo), Bo) - d(p(o), p(Bo)) - 2K_1 - 2K_2 \end{aligned}$$

In the last inequality, we used the basic fact that  $d(A^n o, o) \geq nl_S(A)$ , where  $l_S(A)$  denotes the stable length of the isometry  $A$ . Since  $(n+m)l_S(A) = (n+m+1)l_S(A) - l_S(A) = |A^n BA^m|l_S(A) - l_S(A)$ , we have proved the inequality 5.1 for  $n$  and  $m$  sufficiently large, prescribing  $\lambda = \frac{1}{l_S(A)}$  (recall  $l_S(A) > 0$  when  $A$  is hyperbolic), and  $k = l_S(A) + d(p(o), o) + d(p(Bo), Bo) + d(p(o), p(Bo)) + 2K_1 + 2K_2$ . But there is only a finite number of value of  $A^n BA^m$ , for  $n$  and  $m$  smaller than a fixed constant, so the inequality 5.1 is still true for all  $n, m \in \mathbb{N}$ , after possibly changing the value of  $\lambda$  and  $k$ .

### • Step 2 : From local to global quasi-isometry

We shall now conclude with the local-global lemma, given at the end of section 2.2 (Lemma 2.12).

Let  $L > 0$  and  $(\lambda', k')$  such as in Lemma 2.12, with  $\lambda$  and  $k$  defined in the first step. Fix  $N = \lfloor L \rfloor + 1$ . Then every interval of length smaller than  $L$  is of length smaller than  $N$ . Now choose

$G$  a sequence in  $\mathcal{G}_N(A, B)$  which is associate to a bi-infinite words  $H = (H_n)_{n \in \mathbb{Z}} \in \mathcal{H}_N(A, B)$ . Thus, the subwords of  $H$  of length smaller than  $L$  are of the form  $A^n B A^m$  or  $A^n$ , with  $n, m \in \mathbb{N}$ . Therefore, by Step 1, the sequence of points  $(x_n)_{n \in \mathbb{Z}}$  is a  $(\lambda, k, L)$ -local-quasi-geodesic. So, by the local-global lemma 2.12, there exists  $\lambda' \geq 1, k' \geq 0$  (only depending on  $\lambda$  and  $k$ , that is on  $\delta, A, B$  and  $o$ ), such that  $(x_n)_{n \in \mathbb{Z}}$  is a  $(\lambda', k')$ -quasi-geodesic (global). Thus, the proposition 5.1 is proved.  $\square$

## 5.2 Some properties of Bowditch representations of $\mathbb{F}_2$

Let  $(X, d)$  be a  $\delta$ -hyperbolic space, geodesic and proper, and  $o \in X$  a basepoint.

We establish the useful fact that the image of primitive elements by a Bowditch representation are hyperbolic isometries.

**Lemma 5.2.** *Let  $\rho$  be a Bowditch representation of constants  $(C, D)$ . Then, for every primitive element  $\gamma$  in  $\mathbb{F}_2$ ,  $\frac{1}{C}\|\gamma\| \leq l_S(\rho(\gamma))$ .*

*In particular, for every primitive element  $\gamma$ ,  $\rho(\gamma)$  is hyperbolic and  $\rho$  is also a Bowditch representation of constant  $(C, 0)$ .*

*Proof.* Suppose that  $\gamma$  is cyclically reduced. The primitivity hypothesis on  $\gamma$  gives the existence of another primitive element,  $\delta \in \mathbb{F}_2$ , such that we have both  $\{\gamma, \delta\}$  is a free basis of  $\mathbb{F}_2$  and  $\|\gamma^n \delta\| = n\|\gamma\| + |\delta|$ . Thus, for all  $n \in \mathbb{N}$ , the element  $\gamma^n \delta$  is primitive. The Bowditch inequality applied to  $\gamma^n \delta$  gives :

$$\begin{aligned} \frac{1}{C}\|\gamma^n \delta\| - D &\leq l_\rho(\gamma^n \delta) \leq d(\rho(\gamma^n \delta)o, o) \text{ by definition of the displacement length} \\ &\leq d(\rho(\gamma^n)o, o) + d(\rho(\delta)o, o) \text{ by the triangle inequality} \end{aligned}$$

Using that  $\|\gamma^n \delta\| = n\|\gamma\| + |\delta|$ , and after dividing by  $n$ , we obtain :

$$\frac{1}{C}\|\gamma\| + \frac{|\delta|}{nC} - \frac{D}{n} \leq \frac{1}{n}d(\rho(\gamma)^n o, o) + \frac{1}{n}d(\rho(\delta)o, o)$$

Now, let  $n$  tends to infinity and use the definition of the stable length :

$$\frac{1}{C}\|\gamma\| \leq l_S(\rho(\gamma)).$$

which is indeed the desired inequality.

Thus, the stable length of  $\rho(\gamma)$  is positive, we deduce that  $\rho(\gamma)$  is hyperbolic.

At last, since the stable length is always smaller than or equal to the displacement length (see inequality (2.23)), we also deduce the inequality  $\frac{1}{C}\|\gamma\| \leq l_\rho(\gamma)$ , which finishes the proof.  $\square$

Now we establish the fact that the hypothesis required by Lemma 5.1 is satisfied when the hyperbolic isometries  $A$  and  $B$  comes from a Bowditch representation.

**Lemma 5.3.** *Let  $X$  be a  $\delta$ -hyperbolic space, geodesic and proper, and  $\rho : \mathbb{F}_2 \rightarrow \text{Isom}(X)$  a Bowditch representation. Fix  $\{a, b\}$  a free basis of  $\mathbb{F}_2$  and denote by  $A = \rho(a), B = \rho(b)$  the images of the generators by  $\rho$ .*

*Then  $B(A^+) \neq A^-$  (where  $A^+$  and  $A^-$  refer respectively to the attracting and repelling fixpoints of  $A$ ).*

*Proof.* Before starting the proof, recall that we have shown that  $\rho(a)$  and  $\rho(b)$  are hyperbolic isometries (because  $a$  and  $b$  are primitive elements, see lemma 5.2), therefore  $A^+$  and  $A^-$  are well-defined.

Let us chose some basepoint  $o \in X$ . Then, because  $A$  is hyperbolic, the sequence  $(A^n o)_{n \in \mathbb{Z}}$  is a quasi-isometry with repelling fixpoint  $A^-$ . Furthermore, the sequence  $(BA^m o)_{m \in \mathbb{Z}}$  is again a quasi-isometry, with attracting fixpoint  $B(A^+)$ . Now suppose by absurdity that  $B(A^+) = A^-$ . The stability of quasi-geodesics in  $\delta$ -hyperbolic spaces then gives the existence of a constant  $K > 0$  such that the half-geodesics  $(A^{-n} o)_{n \in \mathbb{N}}$  and  $(BA^m o)_{m \in \mathbb{N}}$  stay at a distance  $K$  of each other. Thus, we deduce the existence, for all  $n \in \mathbb{N}$ , of an integer  $\phi(n) \in \mathbb{N}$  such that  $d(A^{-n} o, BA^{\phi(n)} o) \leq K$ . But the element  $a^n b a^{\phi(n)} \in \mathbb{F}_2$  is primitive and cyclically reduced, so by the Bowditch hypothesis, we have the following inequality :

$$\frac{1}{C} \|a^n b a^{\phi(n)}\| - D \leq d(\rho(a^n b a^{\phi(n)}) o, o) = d(A^n B A^{\phi(n)} o, o) = d(B A^{\phi(n)} o, A^{-n} o)$$

Here the right hand side of the inequality is bounded by  $K$ , and the left hand side tends to infinity because  $\|a^n b a^{\phi(n)}\| = n + \phi(n) + 1$ , this is a contradiction.  $\square$



# Chapter 6

## From Bowditch's hypothesis for $\mathbb{F}_2$ to uniform tubular neighborhoods

The purpose of this section is to show Proposition 6.3, which is the heart of the proof that a Bowditch representation is primitive-stable.

Before stating the proposition and starting the proof, recall that when  $A$  is a hyperbolic isometry of  $X$ , it defines two points in the boundary of  $X$ ,  $A^+$  and  $A^-$ , respectively attracting and repelling fixpoints of the action of  $A$  on  $\partial X$ . Let's denote by  $\text{Axis}(A)$  the union of all the geodesics of  $X$  joining the two points  $A^+$  and  $A^-$ . Since the space  $X$  is proper, this set is non-empty. When  $X = \mathbb{H}^n$  the usual hyperbolic space of dimension  $n$ , the geodesic joining  $A^+$  and  $A^-$  is unique and corresponds to the usual definition of the axis of the hyperbolic isometry  $A$ . The set  $\text{Axis}(A)$  is invariant under  $A$ : indeed, for every geodesic  $\ell$  joining  $A^+$  and  $A^-$  in  $X$ ,  $A(\ell)$  is still a geodesic because  $\ell$  is a geodesic and  $A$  an isometry. Now using the fact that the endpoints of  $\ell$  are the fixpoints at infinity of  $A$ , we deduce that the endpoints of  $A(\ell)$  are also  $A^+$  and  $A^-$ , so  $A(\ell) \subset \text{Axis}(A)$ , thus  $\text{Axis}(A)$  is  $A$ -invariant. For a subset  $Y$  of  $X$  and  $K > 0$ , denote by  $N_K(Y)$  the  $K$ -neighborhood of  $Y$ , that is  $N_K(Y) = \{x \in X : d(x, Y) \leq K\}$ . Fix  $\ell$  any geodesic of  $X$  joining  $A^+$  and  $A^-$ . Then we have the following lemma:

**Lemma 6.1.** *With the previous notations, we have the following inclusions:*

- $N_K(\ell) \subset N_K(\text{Axis}(A))$
- *There exists a constant  $C(\delta)$ , depending only on the hyperbolic constant  $\delta$ , such that  $N_K(\text{Axis}(A)) \subset N_{K+C(\delta)}(\ell)$ .*

*Proof.* • The first point is immediate because  $\ell \subset \text{Axis}(A)$ .

- The second point basically follows from the Morse lemma. Since  $X$  is  $\delta$ -hyperbolic, there exists a constant  $C(\delta)$ , depending only on  $\delta$ , such that any two geodesics with the same endpoints remain at a distance  $C(\delta)$  of each other.

Then, if  $x \in N_K(\text{Axis}(A))$ , there exists  $y \in \text{Axis}(A)$  such that  $d(x, y) \leq K$ . But since  $y \in \text{Axis}(A)$ , in particular,  $y$  belongs to a geodesic with endpoints  $A^+$  and  $A^-$ , let's denote it



by  $\ell_y$ . Thus  $\ell_y$  and  $\ell$  remain at a distance  $C(\delta)$  of each other and thus  $x$  is at distance at most  $K + C(\delta)$  of  $\ell$ . □

Moreover, in the following we will be studying the distance map to  $\text{Axis}(A)$ . Here we state its invariance under the action of  $A$  :

**Lemma 6.2.** *Let  $x$  be a point in  $X$  and  $A$  an hyperbolic isometry of  $X$ . Then*

$$d(x, \text{Axis}(A)) = d(Ax, \text{Axis}(A))$$

*Proof.* The proof is immediate :

$$\begin{aligned} d(x, \text{Axis}(A)) &= d(Ax, A(\text{Axis}(A))) && \text{since } A \text{ is an isometry} \\ &= d(Ax, \text{Axis}(A)) && \text{by } A\text{-invariance of } \text{Axis}(A) . \end{aligned}$$

□

Now we are going to show that the Morse lemma is satisfied for the primitive elements of a Bowditch representation, meaning that the orbit map restricted to primitive leaves stays in a uniform tubular neighborhood of the axis of primitive elements in  $X$ .

**Proposition 6.3.** *Let  $\rho : \mathbb{F}_2 \rightarrow \text{Isom}(X)$  be a Bowditch representation. The orbit map restricted to primitive leaves stays in a uniform tubular neighborhood of the axis of primitive elements in  $X$ . Precisely :*

$$\exists K > 0, \quad \forall \gamma \in \mathcal{P}(\mathbb{F}_2), \quad \tau_\rho(L_\gamma) \subset N_K(\text{Axis}(\rho(\gamma)))$$

Recall that  $L_\gamma$  denotes the geodesic in the Cayley graph of  $\mathbb{F}_2$  generated by  $\gamma$ , and that for any primitive element  $\gamma$  in  $\mathbb{F}_2$ ,  $\rho(\gamma)$  is hyperbolic so  $\text{Axis}(\rho(\gamma))$  is well-defined.

*Proof.* Pick  $\rho$  a Bowditch representation and let  $C > 0, C' > 0$  be two constants such that

$$\forall \gamma \in \mathcal{P}(\mathbb{F}_2), \quad \frac{1}{C} \|\gamma\| \leq l(\rho(\gamma)) \quad \text{and} \quad \forall u \in \mathbb{F}_2, \quad d(\rho(u)o, o) \leq C'|u|.$$

Note that such constants automatically satisfy  $CC' \geq 1$ .

Let us proceed by contradiction and suppose there exists a sequence  $(\gamma_n)_{n \in \mathbb{N}}$  of cyclically reduced primitive elements of  $\mathbb{F}_2$  satisfying the following hypothesis :

$$\sup \{d(x, \text{Axis}(\rho(\gamma_n))) : x \in \tau_\rho(L_{\gamma_n})\} \xrightarrow[n \rightarrow \infty]{} +\infty \tag{H_1}$$

We fix such a sequence  $(\gamma_n)_{n \in \mathbb{N}}$  for all that follows.

**Lemma 6.4.** *Up to subsequence, we can assume that the elements  $\gamma_n$  are pairwise distinct and that  $|\gamma_n| \rightarrow \infty$ .*

*Proof.* Let  $N \in \mathbb{N}$ . Then the set  $\Gamma_N = \{n \in \mathbb{N} : \gamma_n = \gamma_N\}$  is finite. Indeed, if this was not true, there would exist a subsequence  $(\gamma_{\sigma(n)})_{n \in \mathbb{N}}$  such that  $\sup\{d(x, \text{Axis}(\rho(\gamma_N))) : x \in \tau_\rho(L_{\gamma_N})\} = \sup\{d(x, \text{Axis}(\rho(\gamma_{\sigma(n)}))) : x \in \tau_\rho(L_{\gamma_{\sigma(n)}})\}$  and this would contradict the hypothesis  $(H_1)$ . Therefore  $\Gamma_N$  is finite for all  $N \in \mathbb{N}$  and so, after passing to a subsequence, we can assume that the elements  $(\gamma_n)_{n \in \mathbb{N}}$  are pairwise distinct.

For all  $A > 0$ ,  $\{\gamma \in \mathbb{F}_2 : |\gamma| \leq A\}$  is finite, so, since the elements  $(\gamma_n)_{n \in \mathbb{N}}$  are pairwise distinct, we also have the finiteness of the set  $\{n \in \mathbb{N} : |\gamma_n| \leq A\}$  for all  $A > 0$ . Then for  $n$  sufficiently large,  $|\gamma_n| \geq A$ , hence  $|\gamma_n| \xrightarrow[n \rightarrow \infty]{} \infty$ .  $\square$

## 6.1 Continued fraction expansion of $\gamma_n$

The element  $\gamma_n$  is primitive, thus correspond to a rational, and then we can write the continued fraction expansion of its slope :

$$\text{Slope}(\gamma_n) = [N_1^n, \dots, N_{r(n)}^n].$$

Now we will prove that we can restrict our study to the case where the integers  $N_i^n$  are bounded in  $n$  :

**Lemma 6.5.** *Up to subsequence,  $r(n) \rightarrow +\infty$  and for all  $i \in \mathbb{N}$ ,  $(N_i^n)_{n \in \mathbb{N} \mid r(n) \geq i}$  is bounded.*

*Proof.* Suppose there exists  $i \in \mathbb{N}$  such that  $(N_i^n)_n$  is defined for an infinity of  $n$  and is not bounded. Then consider the smallest such  $i \in \mathbb{N}$ . For all  $1 \leq j < i$ , the sequence  $(N_j^n)_n$  is a bounded sequence of integers so after passing to subsequence we assume that there exists an integer  $N_j$  such that for all  $1 \leq j < i$  and for all  $n \in \mathbb{N}$  such that  $r(n) \geq j$ ,  $N_j^n = N_j$ . Thus  $\text{Slope}(\gamma_n) = [N_1, N_2, \dots, N_{i-1}, N_i^n, \dots, N_{r(n)}^n]$ . We set  $u = w_{i-1}(\gamma_n)$  and  $v = w'_{i-1}(\gamma_n)$  (see definition 4.1 in section 4). Therefore,  $\text{Slope}(u) = [N_1, N_2, \dots, N_{i-1}]$ ,  $\text{Slope}(v) = [N_1, N_2, \dots, N_{i-1} + 1]$  (by Proposition 4.3) and  $u$  and  $v$  do not depend on the integer  $n$ . Moreover,  $u$  and  $v$  form a free basis of  $\mathbb{F}_2$  such that (up to cyclic permutation and inversion)  $\gamma_n$  is a positive word on  $u$  and  $v$  (by Proposition 4.3). Denote by  $U = \rho(u)$  and  $V = \rho(v)$  their images by  $\rho$ , then by the lemma 5.3, we conclude  $V(U^+) \neq U^-$ . Then, by considering the bi-infinite word obtained by concatenating infinitely many copies of  $\gamma_n$ , or equivalently the bi-infinite word obtained by following the geodesic  $L_{\gamma_n}$  in the Cayley graph, we can see  $\rho|_{L_{\gamma_n}}$  as an element of  $\mathcal{G}(U, V)$  (the definition is given at the beginning of section 5). Thus, we define  $N \in \mathbb{N}^*$  as in the lemma 5.1 (depending on  $\delta, U, V$  and the basepoint  $o$ ) and since by hypothesis  $N_i^n \rightarrow +\infty$ ,  $\rho|_{L_{\gamma_n}}$  is a sequence of  $\mathcal{G}_N(U, V)$  for  $n$  sufficiently large. Then, using the lemma 5.1, we obtain the existence of two constants  $\lambda > 0$  and  $k \geq 0$  (only depending on  $\delta, U, V$  and the basepoint  $o$ ) such that  $\tau_{\rho|_{L_{\gamma_n}}}$  is a  $(\lambda, k)$ -quasi-geodesic. The Morse lemma now gives the existence of a constant  $K > 0$  only depending on  $\lambda$  and  $k$  such that  $\tau_\rho(L_{\gamma_n})$  remains in the  $K$ -neighborhood of  $\text{Axis}(\rho(\gamma_n))$ . This contradicts our hypothesis  $(H_1)$  on  $\rho$  for  $n$  sufficiently large. Hence, for all  $i \in \mathbb{N}$ ,  $(N_i^n)_n$  is bounded.

Let us now justify that  $r(n) \rightarrow +\infty$ . If  $r(n)$  stays bounded,  $r(n) \leq R$ , then for all  $1 \leq i \leq R$ ,  $(N_i^n)_n$  is bounded by what has been previously done and so the word length of  $\gamma_n$  is also bounded, which is false. Thus  $r(n) \rightarrow +\infty$ . In particular, we deduce that under the assumption  $(H_1)$ , the sequence

$(N_i^n)_n$  is always well-defined for  $n$  sufficiently large ( $n$  such that  $r(n) \geq i$ ). □

## 6.2 Consequence : uniform bound on the lengths $l_i(\gamma_n)$

Using the notations of the previous sections and the definition of  $l_i(\gamma_n)$  given in Definition 4.1, we have, using the inequalities 4.10 and 4.11 of the section 4 together with the upper bound  $N_i^n \leq N_i$  :

$$\forall n \in \mathbb{N}, \forall 1 \leq i \leq r(n), \quad \frac{l_i(\gamma_n)}{l_{i-1}(\gamma_n)} \leq N_i + 1$$

We deduce, since for any integer  $n$ ,  $l_0(\gamma_n) = 1$ , that for any integer  $i$ , there exists a positive constant  $L_i > 0$  such that :

$$\forall n \in \mathbb{N}, \forall 0 \leq i \leq r(n), \quad i \leq l_i(\gamma_n) \leq L_i \tag{6.1}$$

## 6.3 Excursions for real maps

**Definition 6.1.** An *excursion* is the data of two reals  $a \leq b$  and of a map  $E : [a, b] \rightarrow \mathbb{R}$  which satisfies :

- $E$  is continuous on  $[a, b]$
- $E(a) = E(b)$
- $\forall t \in [a, b], E(t) \geq E(a)$

We define the *length of excursion* of  $E$  as the non-negative real  $b - a$ .

Furthermore, the map  $E : [a, b] \rightarrow \mathbb{R}$  is said to be a *K-excursion* if  $E$  is an excursion such that  $E(a) = K$ .

**Definition 6.2.** Let  $E : [a, b] \rightarrow \mathbb{R}$  be an excursion. We say that  $E'$  is a *sub-excursion* of  $E$  if there exists a subinterval  $[c, d] \subset [a, b]$  such that  $E' = E|_{[c, d]}$  and  $E'$  is an excursion.

Furthermore,  $E'$  is said to be a *K-sub-excursion* of  $E$  if  $E'(c) = K$ .

The goal of this section is Lemma 6.11, which shows that an excursion always has sub-excursions of any prescribed length up to a factor of 2.

*Remark 6.6.* Trivially, if  $E$  is an excursion,  $E$  is a sub-excursion of itself and for all  $c \in [a, b]$ ,  $E|_{[c, c]}$  is also a sub-excursion of  $E$ .

**Lemma 6.7.** Let  $E : [a, b] \rightarrow \mathbb{R}$  be an excursion. We set  $K_{\min} = \min E = E(a) = E(b)$  and  $K_{\max} = \max E$ .

Then, for all  $K \in [K_{\min}, K_{\max}]$ , there exists a *K-sub-excursion* of  $E$ .

*Proof.* Let  $K_{\min} \leq K \leq K_{\max}$ . Choose  $c \in [a, b]$  such that  $E(c) = K_{\max}$ . We denote  $X_L = E^{-1}(K) \cap [a, c]$  and  $X_R = E^{-1}(K) \cap [c, b]$ . The sets  $X_L$  and  $X_R$  are closed (by continuity of  $E$ ) and non-empty (by the intermediate value theorem) so we can consider

$$x_K = \max X_L \text{ and } y_K = \min X_R$$

Then  $E|_{[x_K, y_K]}$  is a  $K$ -sub-excursion of  $E$ . □

**Lemma 6.8.** *Let  $l > 0$  and  $E$  be an excursion of length  $l$ . Let  $T_E$  be the set of all lengths of excursion of sub-excursion of  $E$ , that is :*

$$T_E = \{0 \leq l' \leq l : \text{there exists a sub-excursion of } E \text{ of length } l'\}$$

*Then  $T_E$  is a closed subset of  $[0, l]$ .*

*Remark 6.9.* By the previous remark, we always have  $0 \in T_E, l \in T_E$ .

*Proof.* Let  $E : [a, b] \rightarrow \mathbb{R}$  be an excursion of length  $l$ , which means that  $E$  is continuous,  $E(a) = E(b)$ ,  $\forall t \in [a, b], E(t) \geq E(a)$  and  $b - a = l$ .

Let  $(l_n)_{n \in \mathbb{N}}$  be a sequence of  $T_E$  such that  $l_n \rightarrow l_\infty \in [0, l]$ .

Let  $(a_n)_{n \in \mathbb{N}}$  and  $(b_n)_{n \in \mathbb{N}}$  be two sequences of  $[a, b]$  such that  $E : [a_n, b_n] \rightarrow \mathbb{R}$  is a sub-excursion of length  $l_n$ . Up to subsequence, since  $[a, b]$  is compact, we can assume that  $a_n \rightarrow a_\infty \in [a, b]$  and  $b_n \rightarrow b_\infty \in [a, b]$ . Moreover, using the continuity of  $E$ ,  $\forall n \in \mathbb{N}, E(a_n) = E(b_n)$  and  $\forall t \in [a_n, b_n] E(t) \geq E(a_n)$ , we obtain  $E(a_\infty) = E(b_\infty)$  and  $\forall t \in [a_\infty, b_\infty], E(t) \geq E(a_\infty)$ . Finally,  $l_\infty = \lim_n l_n = \lim_n (b_n - a_n) = b_\infty - a_\infty$  so  $E : [a_\infty, b_\infty] \rightarrow \mathbb{R}$  is indeed a sub-excursion of length  $l_\infty$ . □

**Lemma 6.10.** *Let  $l > 0$  and  $E$  an excursion of length  $l$ . Then there exists a sub-excursion of  $E$  of length  $l' > 0$  such that  $\frac{l}{2} \leq l' < l$ .*

*Proof.* Let  $E : [a, b] \rightarrow \mathbb{R}$  be an excursion of length  $l$  (then  $E$  is continuous,  $E(a) = E(b)$ ,  $\forall t \in [a, b], E(t) \geq E(a)$  and  $b - a = l$ ).

We distinguish two cases :

- **1<sup>st</sup> case** : There exists  $t \in ]a, b[$ ,  $E(t) = E(a)$  :  
Then  $E : [a, t] \rightarrow \mathbb{R}$  and  $E : [t, b] \rightarrow \mathbb{R}$  are two sub-excursions of length  $t - a$  and  $b - t$  respectively. But either  $t - a \geq \frac{b-a}{2} = \frac{l}{2}$  or  $b - t \geq \frac{b-a}{2} = \frac{l}{2}$  so one of these two sub-excursion is in fact of length  $\frac{l}{2} \leq l' < l$ .
- **2<sup>nd</sup> case** : For all  $t \in ]a, b[$ ,  $E(t) > E(a)$  :  
Let  $c, d \in ]a, b[$  such that  $d - c \geq \frac{l}{2}$ . The map  $E$  is continuous on the segment  $[c, d]$ . Denote  $\delta = \min_{[c, d]} E$ . Then  $\delta > E(a)$ . Let  $h = \frac{1}{2}(E(a) + \delta)$  and define :

$$a_h = \max\{a' \in [a, c] : E(a') = h\}$$

$$b_h = \min\{b' \in [d, b] : E(b') = h\}$$

The set  $\{a' \in [a, c] : E(a') = h\}$  is non-empty (because  $E(c) \geq \delta > h > E(a)$  and  $E$  is continuous) and closed, so  $a_h$  is well-defined. Likewise,  $b_h$  is well-defined.

Therefore, we have :

- For all  $t \in [c, d]$ ,  $E(t) > h$  because  $h < \delta = \min_{[c,d]} E$
- For all  $t \in [a_h, c]$ ,  $E(t) \geq h$  : indeed, if there was  $t \in [a_h, c]$  such that  $E(t) < h$ , then on one hand  $t \in ]a_h, c[$ , and on the other hand, since  $E(c) > h$ , by the intermediate value theorem, there would exist  $a' \in [t, c]$  such that  $E(a') = h$  and  $a' > a_h$ , which is impossible because of the choice of  $a_h$ .
- For all  $t \in [d, b_h]$ ,  $E(t) \geq h$  : the same argument as above works.

Therefore,  $E : [a_h, b_h] \rightarrow \mathbb{R}$  is an excursion of length  $l' = b_h - a_h$  which satisfies

$$\frac{l}{2} \leq d - c \leq b_h - a_h = l' < b - a = l$$

□

**Lemma 6.11.** *Let  $l > 0$  and  $E$  be an excursion of length  $l$ . Let  $T_E$  be the set of all lengths of excursions of  $E$ . Fix  $0 < a < \frac{l}{2}$ . Then  $T_E \cap [a, 2a] \neq \emptyset$ .*

*Proof.*  $T_E \cap [2a, l]$  is closed (by the lemma 6.8) and non-empty (because  $l \in T_E \cap [2a, l]$ ). Denote  $l' = \min T_E \cap [2a, l]$ . By the lemma 6.10, there exists  $l'' \in T_E$  such that  $\frac{l'}{2} \leq l'' < l'$ . Then  $l'' < 2a$  because  $l'' < l' = \min T_E \cap [2a, l]$  and  $l'' \geq \frac{l'}{2} \geq \frac{2a}{2} = a$ . Therefore,  $l'' \in T_E \cap [a, 2a]$ . □

## 6.4 Excursions of the orbit map

Let  $\gamma$  be a primitive element of  $\mathbb{F}_2$ . Recall that  $L_\gamma$  is the geodesic of the Cayley graph of  $\mathbb{F}_2$  generated by  $\gamma$ . We want to study the following map :  $E_\gamma : L_\gamma \rightarrow \mathbb{R}_+$  such that  $E_\gamma(u) = d(\tau_\rho(u), \text{Axis}(\rho(\gamma)))$ .

**Lemma 6.12.** *The map  $E_\gamma$  is Lipschitz-continuous (hence continuous) and  $\gamma$ -invariant.*

*Proof.* It is a general fact that the distance map to any subspace of a metric space is 1-Lipschitz-continuous, because of the triangle inequality. Since the orbit map  $\tau_{\rho|L_\gamma}$  is Lipschitz-continuous, we deduce the Lipschitz-continuity of  $E_\gamma$ .

The  $\gamma$ -invariance of  $E_\gamma$  follows from the  $\gamma$ -invariance of  $\text{Axis}(\rho(\gamma))$ .

$$\begin{aligned} E_\gamma(\gamma u) &= d(\tau_\rho(\gamma u), \text{Axis}(\rho(\gamma))) = d(\rho(\gamma)\tau_\rho(u), \text{Axis}(\rho(\gamma))) \\ &= d(\tau_\rho(u), \text{Axis}(\rho(\gamma))) \text{ because } \text{Axis}(\rho(\gamma)) \text{ is } \rho(\gamma)\text{-invariant} \\ &= E_\gamma(u) \end{aligned}$$

□

Since  $L_\gamma$  is a geodesic in the Cayley graph of  $\mathbb{F}_2$ , it is isometric to  $\mathbb{R}$ , therefore we can think of  $E_\gamma$  as a map from  $\mathbb{R}$  to  $\mathbb{R}$ . Thus, we can apply the language of excursions defined previously.

**Definition 6.3.** Let  $\gamma$  be a primitive element in  $\mathbb{F}_2$ . Let  $[u, v] \subset L_\gamma$  be a segment of the geodesic  $L_\gamma$ . We say that  $[u, v]$  is an *excursion* if the map  $E_{\gamma|_{[u,v]}}$  is an excursion.

Let  $K \geq 0$ . We say that  $[u, v]$  is a  $K$ -*excursion* if the map  $E_{\gamma|_{[u,v]}}$  is an excursion such that  $E_\gamma(u) = K$ . In this case, we call *length of excursion* of  $[u, v]$  the length of excursion of  $E_{\gamma|_{[u,v]}}$ , that is the non-negative real  $d_C(u, v)$ .

At last, we say that  $\gamma$  has an excursion (respectively a  $K$ -excursion) if there exists  $[u, v] \in L_\gamma$  such that  $[u, v]$  is an excursion (respectively a  $K$ -excursion).

We end this section by showing that, in our context, we can find excursions as big and as long as we want.

**Lemma 6.13.** *There exist two sequences of positive reals  $(K_n)_{n \in \mathbb{N}}$  and  $(l_n)_{n \in \mathbb{N}}$ , such that  $K_n \rightarrow \infty$ ,  $l_n \rightarrow \infty$  and, up to subsequence, for all  $n \in \mathbb{N}$ ,  $\gamma_n$  has a  $K_n$ -excursion of length  $l_n$ .*

*Proof.* Let

$$K_{\max, n} = \max_{[1, \gamma_n]} E_{\gamma_n} \text{ and } K_{\min, n} = \min_{[1, \gamma_n]} E_{\gamma_n}$$

In particular we have  $K_{\max, n} = \max E_{\gamma_n}$  and  $K_{\min, n} = \min E_{\gamma_n}$  since  $E_{\gamma_n}$  is  $\gamma_n$ -invariant (see lemma 6.12). The hypothesis  $H_1$  on the sequence  $(\gamma_n)_{n \in \mathbb{N}}$  means that  $K_{\max, n} \rightarrow \infty$ .

**Fact :** For all  $K_{\min, n} \leq K \leq K_{\max, n}$ ,  $\gamma_n$  has a  $K$ -excursion.

*Proof.* Indeed,  $\gamma_n$  has a  $K_{\min, n}$ -excursion (by  $\gamma_n$  invariance of  $E_{\gamma_n}$ ) so by the lemma 6.7,  $\gamma_n$  has a  $K$ -excursion. □

- If  $(K_{\min, n})_{n \in \mathbb{N}}$  is not bounded, then up to subsequence, we can assume that  $K_{\min, n} \rightarrow \infty$ . By definition of  $K_{\min, n}$ , there exists  $u_n \in [1, \gamma_n]$  such that  $E_{\gamma_n}(u_n) = K_{\min, n}$ , and so  $[u_n, \gamma_n u_n]$  is a  $K_{\min, n}$ -excursion of length  $|\gamma_n|$ . By setting  $K_n = K_{\min, n}$  and  $l_n = |\gamma_n|$ , we then have  $K_n \rightarrow \infty, l_n \rightarrow \infty$  and  $\gamma_n$  has a  $K_n$ -excursion of length  $l_n$ .
- If  $(K_{\min, n})_{n \in \mathbb{N}}$  is bounded, then there exists  $K > 0$  such that for all  $n \in \mathbb{N}$ ,  $K_{\min, n} \leq K$ . Let  $K_n = \frac{K_{\max, n}}{2}$ . Then,  $K_n \rightarrow \infty$  and moreover, for  $n$  sufficiently large,  $K_{\min, n} \leq K \leq K_n < K_{\max, n}$ . So, by the above fact,  $\gamma_n$  has  $K_n$ -excursions. Now let us justify this excursion can be chosen in such a way that its length  $l_n$  satisfies  $l_n \rightarrow \infty$ .  
Let  $n \in \mathbb{N}$ , there exists  $u_n \in [1, \gamma_n]$  such that  $E_{\gamma_n}(u_n) = K_{\max, n} > K_n$  ( $E_{\gamma_n}$  is continuous), so there exists a  $K_n$ -excursion containing  $u_n$ . Denote it by  $[v_n, w_n]$  and set  $l_n = d(v_n, w_n)$ . Now we are going to justify that  $l_n \rightarrow \infty$ .  
Let  $x_n = \tau_\rho(u_n)$ , we have  $d(x_n, \text{Axis}(\rho(\gamma_n))) = K_{\max, n} = 2K_n$ .

Define  $\partial N_{K_n}(\text{Axis}(\rho(\gamma_n))) = \{y \in X : d(y, \text{Axis}(\rho(\gamma_n))) = K_n\}$  and let  $y_n$  be a projection of  $x_n$  on  $\partial N_{K_n}(\text{Axis}(\rho(\gamma_n)))$ . Then  $y_n$  satisfies :  $y_n \in \partial N_{K_n}(\text{Axis}(\rho(\gamma_n)))$  and  $\forall y \in \partial N_{K_n}(\text{Axis}(\rho(\gamma_n)))$ ,  $d(x_n, y_n) \leq d(x_n, y)$ . Since the map  $d(\cdot, \text{Axis}(\rho(\gamma_n)))$  is 1-Lipschitz-continuous, we have :

$$\begin{aligned} & |d(x_n, \text{Axis}(\rho(\gamma_n))) - d(y_n, \text{Axis}(\rho(\gamma_n)))| \leq d(x_n, y_n), \\ \text{hence} \quad & K_n \leq d(x_n, y_n). \end{aligned}$$

In addition, because  $[v_n, w_n]$  is a  $K_n$ -excursion,  $\tau_\rho(v_n)$  and  $\tau_\rho(w_n)$  belong to  $\partial N_{K_n}(\text{Axis}(\rho(\gamma_n)))$  so  $2d(x_n, y_n) \leq d(x_n, \tau_\rho(v_n)) + d(x_n, \tau_\rho(w_n))$ . Then :

$$\begin{aligned} 2K_n &\leq 2d(x_n, y_n) \leq d(x_n, \tau_\rho(v_n)) + d(x_n, \tau_\rho(w_n)) \\ &\leq C'd(u_n, v_n) + C'd(u_n, w_n) \quad \text{because } \tau_\rho \text{ is } C'\text{-Lipschitz-continuous} \\ &= C'd(v_n, w_n) \quad \text{because } u_n \in [v_n, w_n] \\ &= C'l_n \end{aligned}$$

We conclude by using that  $K_n \rightarrow \infty$ .

□

## 6.5 Quasi-loops

**Definition 6.4.** Let  $\varepsilon > 0$  and  $w \in \mathbb{F}_2$  (not necessarily primitive). We say that  $w$  is an  $\varepsilon$ -quasi-loop if we have the following inequality :

$$d(\rho(w)o, o) \leq \varepsilon |w|$$

Thinking of  $\varepsilon$  as very small, an  $\varepsilon$ -quasi-loop is an element that does not displace the points much. Note that the definition of a quasi-loop depends on the representation  $\rho$ .

Let  $\gamma$  be a primitive element of  $\mathbb{F}_2$  and  $u \in L_\gamma$ . We denote by  $[u]$  the integer point in  $L_\gamma$  just before  $u$  (if  $u$  is an integer point in  $L_\gamma$ ,  $[u] = u$ ) and  $[u]$  the integer point of  $L_\gamma$  just after  $u$  (thus  $[u]$  and  $[u]$  are the endpoints of an edge of length 1 in the Cayley graph and  $u$  belongs to this edge).

Recall that we have fixed a (Bowditch) representation  $\rho : \mathbb{F}_2 \rightarrow \text{Isom}(X)$  and that the notions of a  $K$ -excursion and of a  $\varepsilon$ -quasi-loop depend on  $\rho$ .

**Lemma 6.14.** *Let  $\varepsilon > 0$ . There exist  $l_\varepsilon > 0$  and  $K_\varepsilon > 0$  such that for all primitive elements  $\gamma$ , for all  $K \geq K_\varepsilon$ ,  $l \geq l_\varepsilon$ , if  $[u, v]$  is a  $K$ -excursion of length  $l$ , then the element  $w = [u]^{-1}[v]$  (which is a subword of  $\gamma$ ) is an  $\varepsilon$ -quasi-loop.*

*Proof.* Let  $\varepsilon' = \frac{\varepsilon}{2}$ .

Let  $\gamma$  be a primitive element in  $\mathbb{F}_2$  and  $[u, v] \subset L_\gamma$  such that  $[u, v]$  is a  $K$ -excursion of length  $l$ . Then  $d(\tau_\rho(u), \text{Axis}(\rho(\gamma))) = d(\tau_\rho(v), \text{Axis}(\rho(\gamma))) = K$ , for all  $t \in [u, v]$ ,  $d(\tau_\rho(t), \text{Axis}(\rho(\gamma))) \geq K$

and  $d(u, v) = l$ . Choose  $\ell_\gamma$  a geodesic in  $X$  with endpoints  $\rho(\gamma)^+$  and  $\rho(\gamma)^-$ , where  $\rho(\gamma)^+$  and  $\rho(\gamma)^-$  are respectively the attracting and repelling fixpoints of the hyperbolic isometry  $\rho(\gamma)$ . Using the lemma 6.1, we conclude that  $d(\tau_\rho(u), \ell_\gamma) \leq K + C(\delta)$  and  $d(\tau_\rho(v), \ell_\gamma) \leq K + C(\delta)$ , where  $C(\delta)$  is the constant introduced in the lemma. In addition, since for all  $t \in [u, v]$ ,  $d(\tau_\rho(t), \text{Axis}(\rho(\gamma))) \geq K$ , we can also conclude from lemma 6.1 that for all  $t \in [u, v]$ ,  $d(\tau_\rho(t), \ell_\gamma) \geq K$ .

First, let us show that for  $K$  and  $l$  large enough,  $d(\tau_\rho(u), \tau_\rho(v)) \leq \varepsilon' d(u, v) = \varepsilon' l$  :

We denote by  $d = d(\tau_\rho(u), \tau_\rho(v))$  and  $L = \text{length}(\tau_\rho([u, v]))$ . Then, since  $\tau_\rho$  is piecewise geodesic on  $[u, v]$ , we can apply the proposition 2.11 to obtain, after denoting  $D(\delta) = \max(C(\delta), \delta)$  :

1. If  $d \leq 2K + 6\delta$ , then  $L \geq (2^{\frac{d}{2\delta} - \frac{D(\delta)}{\delta} - 5} - 2)\delta$
2. If  $d > 2K + 6\delta$ , then there exists an integer  $n \geq 2$  such that :

$$\begin{cases} L \geq (n-1)(2^{\frac{K}{\delta}-3} - 2)\delta \\ d \leq 18n\delta + 2K + 2C(\delta) \end{cases}$$

On the other hand, we also have that  $L \leq C' d(u, v) = C' l$ . Indeed, this is a consequence of the  $C'$ -Lipschitz-continuity  $\tau_\rho$ . Therefore :

1. If  $d \leq 2K + 6\delta$ , we have :

$$\begin{aligned} (2^{\frac{d}{2\delta} - \frac{D(\delta)}{\delta} - 5} - 2)\delta &\leq L \leq C' l \\ \text{so } 2^{\frac{d}{2\delta} - \frac{D(\delta)}{\delta} - 5} &\leq \frac{C'}{\delta} l + 2 \\ \text{then } d &\leq 2\delta \log_2 \left( \frac{C'}{\delta} l + 2 \right) + 2D(\delta) + 10\delta \\ \text{But } \frac{2\delta \log_2 \left( \frac{C'}{\delta} l + 2 \right) + 2D(\delta) + 10\delta}{l} &\xrightarrow{l \rightarrow +\infty} 0, \end{aligned}$$

so there exists  $l_\varepsilon > 0$  (depending only on  $C', \delta$  and  $\varepsilon$ ) such that :

$$\text{If } l \geq l_\varepsilon \text{ then } d \leq \varepsilon' l.$$

2. If  $d > 2K + 6\delta$ , we have :

$$(n-1)(2^{\frac{K}{\delta}-3} - 2)\delta \leq L \leq C' l \text{ so } l \geq (n-1)(2^{\frac{K}{\delta}-3} - 2) \frac{\delta}{C'}.$$

On the other hand  $d \leq 18n\delta + 2K + 2C(\delta)$ ,

$$\text{then } \frac{d}{l} \leq \frac{18n\delta + 2K + 2C(\delta)}{(n-1)(2^{\frac{K}{\delta}-3} - 2) \frac{\delta}{C'}} = \frac{18\delta + \frac{2K+2C(\delta)}{n}}{(1 - \frac{1}{n})(2^{\frac{K}{\delta}-3} - 2) \frac{\delta}{C'}}.$$

$$\text{But } n \geq 2 \text{ so } 1 - \frac{1}{n} \geq \frac{1}{2} \text{ and } \frac{2K + 2C(\delta)}{n} \leq K + C(\delta),$$

$$\text{therefore } \frac{d}{l} \leq \frac{2C' 18\delta + K + C(\delta)}{\delta (2^{\frac{K}{\delta}-3} - 2)} \xrightarrow{K \rightarrow +\infty} 0.$$



so there exists  $K_\varepsilon > 0$  (depending only on  $C', \delta$  and  $\varepsilon$ ) such that if  $K \geq K_\varepsilon$ , then  $d \leq \varepsilon' l$ .

Thus we have shown that if  $K \geq K_\varepsilon$  and  $l \geq l_\varepsilon$ , we have in every case  $d \leq \varepsilon' l$ .

Now, let us show that this implies that  $w = [u]^{-1}[v]$  is an  $\varepsilon$ -quasi-loop.

$$\begin{aligned}
d(\rho(w)o, o) &= d(\rho([u]^{-1}[v])o, o) = d(\rho([u])o, \rho([v])o) = d(\tau_\rho([u]), \tau_\rho([v])) \\
&\leq d(\tau_\rho([u]), \tau_\rho(u)) + d(\tau_\rho(u), \tau_\rho(v)) + d(\tau_\rho(v), \tau_\rho([v])) \text{ by the triangle inequality} \\
&\leq 2C' + d \text{ because } u \text{ and } [u] \text{ are at a distance less than 1 in the Cayley graph} \\
&\leq 2C' + \varepsilon' d(u, v) \text{ by what have been previously done} \\
&\leq 2C' + \varepsilon' (d([u], [v]) + d([v], v) - d([u], u)) \text{ because } [u], u, [v], v \text{ are aligned in this order on } L_\gamma \\
&\leq 2C' + 1 + \varepsilon' |w|.
\end{aligned}$$

Let us further assume that  $l \geq \frac{2C'+1}{\varepsilon'} + 1$ . Then in particular  $|w| = d([u], [v]) = d([u], u) + d(u, v) - d([v], v) \geq l - 1 \geq \frac{2C'+1}{\varepsilon'}$ . Therefore :

$$d(\rho(w)o, o) \leq 2\varepsilon'|w| = \varepsilon|w|$$

Thus, after possibly changing  $l_\varepsilon$  to  $\max(l_\varepsilon, \frac{2C'+1}{\varepsilon} + 1)$ , we have shown that if  $l \geq l_\varepsilon$  and  $K \geq K_\varepsilon$ , then  $w$  is an  $\varepsilon$ -quasi-loop. □

## 6.6 Induction step

Let  $n \in \mathbb{N}$  and  $0 \leq i \leq r(n)$ . Recall that the notations  $w_i(\gamma_n)$  and  $w'_i(\gamma_n)$  have been defined in the definition 4.1, and refer to some specific subwords of (a cyclic permutation of)  $\gamma_n$ , corresponding to a truncation of the continued fraction expansion of the slope of  $\gamma_n$ . The integers  $l_i(\gamma_n) = |w_i(\gamma_n)|$  and  $l'_i(\gamma_n) = |w'_i(\gamma_n)|$  refer to their lengths and  $r(n)$  is the depth of the continued fraction expansion of the slope  $\gamma_n$ . In order to reduce the amount of notations, we write more simply  $w_i(n)$ ,  $w'_i(n)$  and  $l_i(n)$ ,  $l'_i(n)$ .

Let  $\widehat{w}_i(n)$  be a cyclic permutation of  $w_i(n)$  and  $\widehat{w}'_i(n)$  a cyclic permutation of  $w'_i(n)$  adapted to  $\widehat{w}_i(n)$ . Recall that, by the lemma 4.5, there exists a cyclic permutation of  $\gamma_n$  that can be written on the alphabet  $\{\widehat{w}_i(n), \widehat{w}'_i(n)\}$ . Thus, a subword  $u$  of  $\gamma_n$  can be written in the following way :

$$u = pw^1 \dots w^b s$$

with :

- $b \in \mathbb{N}$

- $p$  is a suffix of either  $w_i(\widehat{n})$  or  $w'_i(\widehat{n})$
- $s$  is a prefix of either  $w_i(\widehat{n})$  or  $w'_i(\widehat{n})$
- For all  $1 \leq k \leq b$ ,  $w^k \in \{w_i(\widehat{n}), w'_i(\widehat{n})\}$

Recall that the constants  $C$  and  $C'$  have been chosen at the beginning of the proof of Proposition 6.3 and satisfy :

$$\forall \gamma \in \mathcal{P}(\mathbb{F}_2), \quad \frac{1}{C} \|\gamma\| \leq l(\rho(\gamma)), \quad \forall u \in \mathbb{F}_2, \quad d(\rho(u)o, o) \leq C'|u| \quad \text{and} \quad CC' \geq 1.$$

In the following lemma, we find an  $\varepsilon$ -quasi-loop in a cyclic permutation of  $w_i(n)$  which occupy at least half of its length. We also ask that the remainder of the cyclic permutation of  $w_i(n)$  which is not in the quasi-loop is sufficiently large (to be able later on to continue the process of finding quasi-loop inside) and that the length of  $w_i(n)$  is not too big (to be able to control the number of  $w_i(n)$  we can find).

**Lemma 6.15.** *Let  $0 < \varepsilon < \frac{1}{C}$  and  $\alpha > 6$ . Fix  $r_0 = 4 + \frac{2\varepsilon}{C'}$ . Let  $r \geq r_0$ .*

*There exists a constant  $R > 0$  and two integers  $n_0 \in \mathbb{N}, i \in \mathbb{N}$  such that, for all integer  $n \geq n_0$  the following properties are satisfied :*

1.  $1 \leq i \leq r(n)$
2.  $l_{i-1}(n) \geq r$
3.  $l_i(n) \leq \frac{R}{\alpha}$
4. *There exists a cyclic permutation of  $w_i(n)$ , denoted by  $\widehat{w}_i(n)$  such that  $\widehat{w}_i(n) = v_1 v_2$ , with  $v_1$  and  $v_2$  two elements of  $\mathbb{F}_2$  satisfying the following properties :*
  - (a)  $v_1$  is an  $\varepsilon$ -quasi-loop
  - (b)  $|v_1| \geq |v_2|$
  - (c)  $|v_2| \geq r$

*Proof.* First of all, let's consider two sequences  $(K_n)_{n \in \mathbb{N}}$  and  $(l_n)_{n \in \mathbb{N}}$  as in the lemma 6.13. Then  $K_n \rightarrow \infty$ ,  $l_n \rightarrow \infty$  and for all  $n \in \mathbb{N}$ ,  $\gamma_n$  has a  $K_n$ -excursion of length  $l_n$ . Now, let's introduce the constants  $K_{\frac{\varepsilon}{2}}$  and  $l_{\frac{\varepsilon}{2}}$  given by the lemma 6.14 for  $\frac{\varepsilon}{2}$ . In order to simplify the notation, we still denote by  $K_\varepsilon$  and  $l_\varepsilon$  these two constants. Then, there exists an integer  $n_1 \in \mathbb{N}$  such that for all integers  $n \geq n_1$ , we have  $l_n \geq l_\varepsilon$  and  $K_n \geq K_\varepsilon$ . Now, let  $r' = \frac{C'r}{\frac{1}{C} - \varepsilon}$ . Then, because  $CC' \geq 1$ , we have

$r' = \frac{C'r}{\frac{1}{C} - \varepsilon} \geq CC'r \geq r$ . Let  $l(r', \varepsilon) = \max(r' + 1, 2l_\varepsilon)$ . Since  $r(n) \rightarrow \infty$  by the lemma 6.5, we deduce

the existence of an integer  $n_2 \in \mathbb{N}$  such that for all integers  $n \geq n_2$ , we have  $r(n) \geq l(r', \varepsilon)$ . Let us consider  $i$  the smallest integer such that  $i \geq l(r', \varepsilon)$ . Then for all  $n \geq n_2$ , we have  $l(r', \varepsilon) \leq i \leq r(n)$  (because  $r(n)$  is an integer). Since  $l_n \rightarrow \infty$ , we can find  $n_3 \in \mathbb{N}$  such that for all  $n \geq n_3$ , we have  $L_i < l_n$  (recall that  $L_i$  is a constant introduced in 6.2 which satisfies  $l_i(n) \leq L_i$  for all  $n \in \mathbb{N}$ ). Then, set  $n_0 = \max(n_1, n_2, n_3)$  and let's summarise the inequalities that are true for all integers  $n \geq n_3$  :

$$l_n \geq l_\varepsilon, K_n \geq K_\varepsilon, r(n) \geq r' + 1, r(n) \geq 2l_\varepsilon, l_n > L_i \text{ and } l(r', \varepsilon) \leq i \leq r(n).$$

Finally, we set  $R = \alpha L_i$ .

Now that all these constants have been introduced, we show that this choice of  $n_0, i$  and  $R$  satisfies the property requested in the lemma. Let  $n \geq n_0$ . We can easily check the first three properties :

1.

$$\begin{aligned} r(n) &\geq i \geq l(r', \varepsilon) \geq r' + 1 \text{ because } l(r', \varepsilon) = \max(r', 2l_\varepsilon - 1) \\ &\geq r + 1 \geq r_0 \text{ because } r \text{ is chosen larger than } r_0 \\ &> 4 \text{ because } r_0 = 4 + \frac{2\varepsilon}{C'}, \end{aligned}$$

hence we have  $1 \leq i \leq r(n)$ .

2.

$$\begin{aligned} l_{i-1}(n) &\geq i - 1 \text{ by the inequalities of 6.2} \\ &\geq r \text{ as already seen above} \end{aligned}$$

3.

$$\begin{aligned} l_i(n) &\leq L_i \text{ by the inequalities of 6.2} \\ &= \frac{R}{\alpha} \text{ by definition of } R \end{aligned}$$

Now let us show the fourth property.

The element  $\gamma_n$  has a  $K_n$ -excursion of length  $l_n$ . But  $l_i(n) \leq L_i < l_n$ , so we can use lemma 6.11 with  $a = \frac{l_i(n)}{2}$  to show the existence of a  $K'_n$ -sub-excursion of length  $l'_n \in [a, 2a[$ . Denote it by  $[u', v']$ . Then we have  $d(u', v') = l'_n$ ,  $K'_n \geq K_n$  and  $\frac{l_i(n)}{2} \leq l'_n < l_i(n)$ . Then, since  $K_n \geq K_\varepsilon$ , we deduce  $K'_n \geq K_\varepsilon$ . In addition :

$$\begin{aligned} l'_n &\geq \frac{l_i(n)}{2} \geq \frac{i}{2} \text{ by the inequalities of 6.2} \\ &\geq \frac{l(r', \varepsilon)}{2} \text{ because } i \geq l(r', \varepsilon) \\ &\geq \frac{2l_\varepsilon}{2} \text{ by definition of } l(r', \varepsilon) \\ &= l_\varepsilon. \end{aligned}$$

We apply Lemma 6.14 to  $[u', v']$  in order to show that the subword  $v_1 := [u']^{-1}[v']$  of (a cyclic permutation of)  $\gamma_n$  is an  $\frac{\varepsilon}{2}$ -quasi-loop. Let us now look at the length of  $v_1$ .

$$\begin{aligned} \text{We have} \quad & |v_1| = d([u'], [v']) = d([u'], u') + d(u', v') - d([v'], v') \\ \text{Hence} \quad & l'_n - 1 < |v_1| < l'_n + 1, \\ \text{so} \quad & \frac{l_i(n)}{2} - 1 < |v_1| < l_i(n) + 1. \\ \text{Then} \quad & \frac{l_i(n)}{2} - \frac{1}{2} \leq |v_1| \leq l_i(n) \end{aligned}$$

Note that, after possibly deleting the last letter of  $v_1$  or adding a letter at the end of  $v_1$ , we can in fact assume that the resulting word, which we denote by  $v_1$  again, satisfies  $\frac{l_i(n)}{2} \leq |v_1| \leq l_i(n) - 1$ . Indeed :

- If  $|v_1| = l_i(n)$ , write  $v_1 = v'_1 s$ , with  $|s| = 1$ . Then  $|v'_1| = l_i(n) - 1$ , and we also have  $|v'_1| \geq \frac{l_i(n)}{2}$ , because  $l_i(n) \geq 2$  (since  $i \geq 1$ ).
- If  $|v_1| < \frac{l_i(n)}{2}$ , write  $v'_1 = v_1 s$ , with  $|s| = 1$ . Then  $|v'_1| = |v_1| + 1 < \frac{l_i(n)}{2} + 1 \leq l_i(n)$ , so  $|v_1| + 1 \leq l_i(n) - 1$ , and  $\frac{l_i(n)}{2} \leq \frac{l_i(n)}{2} + \frac{1}{2} < |v_1| + 1$ .

**Lemma 6.16.** *Let  $\varepsilon > 0$ . Let  $w \in \mathbb{F}_2$  be an  $\varepsilon$ -quasi-loop of length  $|w| \geq \frac{C'}{\varepsilon}$ . Then, after deleting the last letter of  $w$  or adding a letter at the end of  $w$ , the resulting word is an  $2\varepsilon$ -quasi-loop.*

*Proof.* • If  $w' = ws$ , with  $|s| = 1, |w'| = |w| + 1$  :

$$\begin{aligned} d(\rho(w')o, o) &= d(\rho(ws)o, o) \leq d(\rho(ws)o, \rho(w)o) + d(\rho(w)o, o) \\ &\leq d(\rho(s)o, o) + \varepsilon|w| \quad \text{because } w \text{ is an } \varepsilon\text{-quasi-loop} \\ &\leq C' + \varepsilon|w| \quad \text{since } |s| = 1 \\ &\leq 2\varepsilon|w| \quad \text{because } C' \leq \varepsilon|w| \end{aligned}$$

- If  $w = w's$ , with  $|s| = 1, |w'| = |w| - 1$  :

$$\begin{aligned} d(\rho(w')o, o) &\leq d(\rho(w')o, \rho(w's)o) + d(\rho(w's)o, o) \\ &\leq d(\rho(s)o, o) + d(\rho(w)o, o) \\ &\leq C' + \varepsilon|w| \quad \text{because } w \text{ is an } \varepsilon\text{-quasi-loop and } |s| = 1 \\ &\leq 2\varepsilon|w| \quad \text{because } C' \leq \varepsilon|w| \end{aligned}$$

□

Thus by lemma 6.16,  $v_1$  is an  $\varepsilon$ -quasi-loop.

Since  $|v_1| \leq l_i(n) - 1 \leq |\gamma_n|$ , there exists a subword  $v_3$  of (a cyclic permutation of)  $\gamma_n$  of length  $l_i(n)$  that can be written  $v_3 = v_1 v_2$ , with  $1 \leq |v_2| \leq |v_3| = l_i(n)$ . Since  $v_3$  is of length  $l_i(n)$ , we can again use the Proposition 4.6 to ensure that after possibly changing the last letter of  $v_3$ , that is the last letter of  $v_2$  (because  $v_2$  is non empty),  $v_3$  is in fact a cyclic permutation of  $w_i(n)$ . Then,

noting again  $v_3$  and  $v_2$  after this potential change of letter, there exists a cyclic permutation of  $w_i(n)$ , which we denote  $\widehat{w}_i(n)$ , such that  $w_i(n) = v_1 v_2$ . Recall that we have already shown that  $v_1$  is an  $\varepsilon$ -quasi-loop, and because  $|v_1| \geq \frac{l_i(n)}{2}$ , we have  $|v_1| \geq |v_2|$ . So we still have to show that  $|v_2| \geq r$  to finish the proof of the fourth point. We proceed as follows :

$$\begin{aligned} \frac{1}{C} l_i(n) &\leq d(\rho(\widehat{w}_i(n))o, o) && \text{by the Bowditch hypothesis, because } \widehat{w}_i(n) \text{ is primitive} \\ &\leq d(\rho(v_1 v_2)o, o) && \text{since } \widehat{w}_i(n) = v_1 v_2 \\ &\leq d(\rho(v_1 v_2)o, \rho(v_1)o) + d(\rho(v_1)o, o) && \text{by the triangle inequality} \\ &= d(\rho(v_2)o, o) + d(\rho(v_1)o, o) && \text{because } \rho(v_1) \text{ is an isometry} \\ &\leq C'|v_2| + \varepsilon|v_1| && \text{since } v_1 \text{ is an } \varepsilon\text{-quasi-loop} \\ &\leq C'|v_2| + \varepsilon l_i(n) && \text{because } |v_1| \leq l_i(n). \end{aligned}$$

$$\begin{aligned} \text{Therefore } |v_2| &\geq \frac{1}{C'} \left( \frac{1}{C} - \varepsilon \right) l_i(n) \geq \frac{1}{C'} \left( \frac{1}{C} - \varepsilon \right) r' && \text{because } l_i(n) \geq r', \\ &\geq \frac{1}{C'} \left( \frac{1}{C} - \varepsilon \right) \frac{C'}{\frac{1}{C} - \varepsilon} r = r, && \text{which finishes the proof that } |v_2| \geq r \end{aligned}$$

□

The following lemma aims, when given a sufficiently large subword of some  $\gamma_n$ , to write it as a concatenation of subwords being either  $\varepsilon$ -quasi-loops or sufficiently large "remainders", and such that the proportion of the word in an  $\varepsilon$ -quasi-loop is at least  $c$ , where  $c$  is a constant between 0 and  $\frac{1}{4}$ , fixed in advance. It will be used recursively in the next lemma.

**Lemma 6.17.** *Let  $0 < \varepsilon < \frac{1}{C}$  and  $0 < c < \frac{1}{4}$ . Fix  $r_0 = 4 + \frac{2\varepsilon}{C'}$  and let  $r \geq r_0$ . There exists a constant  $R > 0$  and an integer  $n_0 \in \mathbb{N}$ , such that, given any integer  $n \geq n_0$  and any subword  $u$  of  $\gamma_n$  such that  $|u| \geq R$ , then there exists a positive integer  $q \in \mathbb{N}^*$ , a subset  $QL \subset \{1, \dots, q\}$  and  $q$  words  $u_1, \dots, u_q \in \mathbb{F}_2$  such that :*

1.  $u = u_1 \cdots u_q$
2. For all  $k \in QL$ ,  $u_k$  is an  $\varepsilon$ -quasi-loop
3.  $\sum_{k \notin QL} |u_k| \leq (1 - c)|u|$
4. For all  $k \notin QL$ ,  $|u_k| \geq r$

*Proof.* Let  $b = \frac{8c+2}{1-4c}$ . Then  $c = \frac{b-2}{4b+8}$  and for all  $b' \geq b$ , we have  $\frac{b'-2}{4b'+8} \geq c$ . In addition, since  $0 < c < \frac{1}{4}$ , we have  $b > 2$ . Let  $\alpha = 2b + 4$ , we have  $\alpha > 8$ .

Now let us introduce the constants  $R > 0$ ,  $i$  and  $n_0$  given by the lemma 6.15. Let  $n \geq n_0$  be an integer and  $u$  a subword of  $\gamma_n$  such that  $|u| \geq R$ . Then, the lemma 6.15 states that  $1 \leq i \leq r(n)$ ,  $l_{i-1}(n) \geq r$ ,  $l_i(n) \leq \frac{|u|}{\alpha}$ , and there exists a cyclic permutation of  $w_i(n)$ , denoted by  $\widehat{w}_i(n)$ , that decomposes into the form  $w_i(n) = v_1 v_2$ , with  $v_1$  an  $\varepsilon$ -quasi-loop and  $|v_1| \geq |v_2| \geq r$ . Let  $w'_i(n)$  be a

cyclic permutation of  $w'_i(n)$  adapted to  $w_i(\widehat{n})$  (see the lemma 4.5).

Then we can write a decomposition of  $u$  under the form :

$$u = pw_1 \cdots w_{b'}s$$

with :

- $b \in \mathbb{N}$
- $p$  a suffix of  $w_i(\widehat{n})$  or  $w'_i(\widehat{n})$
- $s$  a prefix of  $w_i(\widehat{n})$  or  $w'_i(\widehat{n})$
- For all  $1 \leq k \leq b'$ ,  $w_k \in \{w_i(\widehat{n}), w'_i(\widehat{n})\}$

The lemma 6.15 ensures that  $l_i(n) \leq \frac{|u|}{\alpha}$ . Therefore we can use the lemma 4.7 to conclude that  $b' \geq \frac{\alpha-4}{2} = b > 2$ . Namely there is at least three central blocs in the decomposition ( $b'$  is an integer). Denote  $p' = pw_1$  and  $s' = w_{b'}s$ . We have :

$$\begin{aligned} |p'| &\geq |w_1| \text{ because } |p'| = |p| + |w_1| \\ &\geq l_i(n) \text{ since } l'_i(n) \geq l_i(n) \\ &\geq l_{i-1}(n) \text{ because the sequence } (l_i(n))_i \text{ is increasing} \\ &\geq r \text{ as provided by the lemma 6.15.} \end{aligned}$$

We also obtain  $|s'| \geq l_i(n) \geq r$ .

Therefore the word  $u$  can be written :  $u = p'w_2 \cdots w_{b'-1}s'$ .

Moreover, by the lemma 4.5,  $w_i(\widehat{n})$  is either a prefix or a suffix of  $w'_i(\widehat{n})$  so there exists a word  $w$  such that  $w'_i(\widehat{n}) = ww_i(\widehat{n})$  or  $w'_i(\widehat{n}) = w_i(\widehat{n})w$ . In addition,  $w_i(\widehat{n}) = v_1v_2$ , so  $w'_i(\widehat{n}) = wv_1v_2$  or  $w'_i(\widehat{n}) = v_1v_2w$ . Then, for all  $k \in \{2, \dots, b'-1\}$ ,  $w_k \in \{w_i(\widehat{n}), w'_i(\widehat{n})\}$  so  $w_k$  is a concatenation of  $w, v_1$  and  $v_2$ . In addition,  $v_1$  is an  $\varepsilon$ -quasi-loop (as provided by the lemma 6.15), and we have :

$$\begin{aligned} |w| &= l'_i(n) - l_i(n) \text{ because } |w'_i(\widehat{n})| = |w| + |w_i(\widehat{n})| \\ &= l_{i-1}(n) \text{ because } l'_i(n) = l_i(n) + l_{i-1}(n) \\ &\geq r \text{ by the lemma 6.15,} \end{aligned}$$

on the other hand,  $|v_2| \geq r$  still by lemma 6.15.

Since we have previously shown that  $|p'| \geq r, |s'| \geq r$ , we can indeed write a decomposition of  $u$  into the form  $u = u_1 \cdots u_q$  (with  $u_1 = p'$  and  $u_q = s'$ ) such that there exists a subset  $QL \subset \{1, \dots, q\}$ , such that for all  $k \in QL, u_k$  is an  $\varepsilon$ -quasi-loop and for all  $k \notin QL, |u_k| \geq r$ . Moreover,  $\#QL = b' - 2$

since each bloc  $w_2, \dots, w_{b'-1}$  contains the  $\varepsilon$ -quasi-loop  $v_1$  exactly once. It remains to show that  $\sum_{k \notin QL} |u_k| \leq (1-c)|u|$ . In order to do so, let us find a lower bound on the total length of the  $\varepsilon$ -quasi-loops :

$$\begin{aligned} \sum_{k \in QL} |u_k| &= (b' - 2)|v_1| && \text{since the quasi-loop } v_1 \text{ appears exactly } b' - 2 \text{ times in our decomposition,} \\ &\geq (b' - 2) \frac{l_i(n)}{2} && \text{because } |v_1| \geq |v_2| \text{ by the lemma 6.15} \end{aligned}$$

$$\begin{aligned} \text{But } |u| &= |p| + \sum_{k=1}^{b'} |w_k| + |s| && \text{because } u = pw_1 \cdots w_{b'}s \\ &\leq |p| + b' \max\{l'_i(n), l_i(n)\} + |s| && \text{because } w_k \in \{w_i(\widehat{n}), w'_i(\widehat{n})\} \\ &\leq (b' + 2) \max\{l'_i(n), l_i(n)\} && \text{since } p \text{ (resp. } s) \text{ is a suffix (resp. prefix) of } w_i(\widehat{n}) \text{ or } w'_i(\widehat{n}) \\ &\leq (b' + 2)l'_i(n) && \text{because } l_i(n) \leq l'_i(n) \\ &\leq 2(b' + 2)l_i(n) && \text{because } l'_i(n) \leq 2l_i(n) \end{aligned}$$

$$\begin{aligned} \text{Therefore } \sum_{k \in QL} |u_k| &\geq \frac{b' - 2}{2} l_i(n) \geq \frac{b' - 2}{4(b' + 2)} |u| \\ &\geq \frac{b - 2}{4(b + 2)} |u| && \text{because we have shown at the beginning of the proof that } b' \geq b \\ &= c|u| && \text{by definition of } b. \end{aligned}$$

The last inequality can be rewritten as follows :  $\sum_{k \notin QL} |u_k| \leq (1-c)|u|$ , which completes the proof.  $\square$

## 6.7 Final contradiction and conclusion

Now, we are able to find a primitive element  $\gamma$  (from the sequence  $(\gamma_n)_{n \in \mathbb{N}}$ ) which contains a very large proportion of quasi-loops.

**Lemma 6.18.** *Let  $0 < \varepsilon < \frac{1}{C}$  and  $1 - \frac{1}{C}(\frac{1}{C} - \varepsilon) < \lambda < 1$ . There exists a (cyclically reduced) primitive element  $\gamma$  such that  $\gamma$  contains  $\varepsilon$ -quasi-loops that occupy at least a proportion  $\lambda$  of  $\gamma$ .*

*Proof.* Let  $0 < c < \frac{1}{4}$  and  $r_0 = 4 + \frac{2\varepsilon}{C}$ . Precisely, we will show the following property by recursion on  $k \in \mathbb{N}$  :

For any integer  $k \in \mathbb{N}$ , for any real  $r \geq r_0$ , there exists an integer  $n_0 \in \mathbb{N}$ , such that for all  $n \geq n_0$ , there exists an integer  $q \in \mathbb{N}^*$ , a subset  $QL \subset \{1, \dots, q\}$ , and some elements  $u_1, \dots, u_q \in \mathbb{F}_2$  satisfying the following properties :

1.  $\gamma_n = u_1 \cdots u_q$
2. For all  $i \in QL$ ,  $u_i$  is an  $\varepsilon$ -quasi-loop
3.  $\sum_{i \notin QL} |u_i| \leq (1-c)^k |\gamma_n|$
4. For  $i \notin QL$ ,  $|u_i| \geq r$

- For  $k = 0$ , it's trivial, it is sufficient to choose  $n$  large enough so that  $|\gamma_n| \geq r$ ,  $q = 1$ ,  $QL = \emptyset$  and thus the properties are satisfied.
- Suppose that this is true for some  $k$ . Let  $r \geq r_0$ . Let us introduce the constants  $R > 0$  and  $n_0 \in \mathbb{N}$  given by the lemma 6.17. Now, let us apply the recursion hypothesis to  $r_1 = \max(R, r_0)$ . Then, there exists an integer  $n_1 \in \mathbb{N}$  such that for all  $n \geq n_1$ , there exists  $q \in \mathbb{N}^*$ ,  $QL \subset \{1, \dots, q\}$  and  $u_1, \dots, u_q$  such that  $\gamma_n = u_1 \cdots u_q$ , for all  $i \in QL$ ,  $u_i$  is an  $\varepsilon$ -quasi-loop,  $\sum_{i \notin QL} |u_i| \leq (1-c)^k |\gamma_n|$  and for all  $i \notin QL$ ,  $|u_i| \geq r_1 \geq R$ . This is still true for all integers  $n \geq \max(n_0, n_1)$ . Then, since for all  $i \notin QL$ ,  $u_i$  is a subword of  $\gamma_n$ , with  $n \geq n_0$ , and  $|u_i| \geq R$ , we can apply the lemma 6.17 to each  $u_i \notin QL$ . That is, for all  $i \notin QL$ , there exists an integer  $q_i \in \mathbb{N}^*$ , a subset  $QL_i \subset \{1, \dots, q_i\}$ , and  $q_i$  elements  $u_{i,1}, \dots, u_{i,q_i} \in \mathbb{F}_2$  such that :  $u_i = u_{i,1} \cdots u_{i,q_i}$ , for all  $j \in QL_i$ ,  $u_{i,j}$  is an  $\varepsilon$ -quasi-loop,  $\sum_{j \notin QL_i} |u_{i,j}| \leq (1-c)|u_i|$  and for all  $j \notin QL_i$ ,  $|u_{i,j}| \geq r$ . Then we have :

1.

$$\gamma_n = \prod_{i=1}^q \begin{cases} u_i & \text{if } i \in QL \\ u_{i,1} \cdots u_{i,q_i} & \text{if } i \notin QL \end{cases}$$

(here the product denotes the concatenation)

2. For all  $i \in QL$ ,  $u_i$  is an  $\varepsilon$ -quasi-loop and for all  $i \notin QL$ , for all  $j \in QL_i$ ,  $u_{i,j}$  is an  $\varepsilon$ -quasi-loop.
3. We have

$$\sum_{i \notin QL} \sum_{j \notin QL_i} |u_{i,j}| \leq \sum_{i \notin QL} (1-c)|u_i| = (1-c) \sum_{i \notin QL} |u_i| \leq (1-c)(1-c)^k |\gamma_n| = (1-c)^{k+1} |\gamma_n|.$$

4. For all  $i \notin QL$ , for all  $j \notin QL_i$ ,  $|u_{i,j}| \geq r$

which completes the proof of the recursion.

Thus, since  $0 < 1-c < 1$  and  $0 < \lambda < 1$ , there exists an integer  $k$  such that  $(1-c)^k < 1-\lambda$  (simply choose  $k = \lceil \frac{\ln(1-\lambda)}{\ln(1-c)} \rceil$ ), which completes the proof of the lemma.  $\square$

Recall that the constants  $C$  and  $C'$  satisfy : for all primitive elements  $\gamma$ ,  $\frac{1}{C}|\gamma| \leq l(\rho(\gamma)) \leq C'|\gamma|$ . Then, in particular  $CC' \geq 1$ . Let  $0 < \varepsilon < \frac{1}{C}$ . Therefore

$$\frac{1}{C'}\left(\frac{1}{C} - \varepsilon\right) < \frac{1}{C'}\frac{1}{C} \leq 1 \quad \text{so} \quad 0 < 1 - \frac{1}{C'}\left(\frac{1}{C} - \varepsilon\right) < 1.$$



**Lemma 6.19.** *Let  $0 < \varepsilon < \frac{1}{C}$  and  $1 - \frac{1}{C'}(\frac{1}{C} - \varepsilon) < \lambda < 1$ . Let  $\gamma$  be a primitive element of  $\mathbb{F}_2$  which contains  $\varepsilon$ -quasi-loops which occupy at least a proportion  $\lambda$  of  $\gamma$ . Then*

$$d(\rho(\gamma)o, o) < \frac{1}{C}|\gamma|.$$

*Proof.* Since we can find  $\varepsilon$ -quasi-loops in  $\gamma$  which occupy at least a proportion  $\lambda$  of  $\gamma$ , there exists  $p \in \mathbb{N}$ ,  $I \subset \{1, \dots, p\}$  and some elements  $u_1, \dots, u_p$  such that we can write  $\gamma$  in the following way :  $\gamma = u_1 \cdots u_p$ , and  $\forall i \in I$ ,  $u_i$  is an  $\varepsilon$ -quasi-loop and  $\sum_{i \in I} |u_i| \geq \lambda|\gamma|$ . Then we have :

$$\sum_{i \in \{1, \dots, p\} \setminus I} |u_i| = |\gamma| - \sum_{i \in I} |u_i| \leq |\gamma| - \lambda|\gamma| = (1 - \lambda)|\gamma| \quad (6.2)$$

Thus :

$$\begin{aligned} d(\rho(\gamma)o, o) &\leq \sum_{i=1}^p d(\rho(u_i)o, o) \text{ by the triangle inequality} \\ &= \sum_{i \in I} d(\rho(u_i)o, o) + \sum_{i \in \{1, \dots, p\} \setminus I} d(\rho(u_i)o, o) \\ &\leq \sum_{i \in I} \varepsilon|u_i| + \sum_{i \in \{1, \dots, p\} \setminus I} d(\rho(u_i)o, o) \text{ because } \forall i \in I, u_i \text{ is an } \varepsilon\text{-quasi-loop} \\ &\leq \varepsilon \sum_{i \in I} |u_i| + \sum_{i \in \{1, \dots, p\} \setminus I} C'|u_i| \text{ because } \forall u \in \mathbb{F}_2, d(\rho(u)o, o) \leq C'|u| \\ &\leq \varepsilon|\gamma| + C' \sum_{i \in \{1, \dots, p\} \setminus I} |u_i| \\ &\leq \varepsilon|\gamma| + C'(1 - \lambda)|\gamma| \text{ by the inequality (6.2)} \\ &< \varepsilon|\gamma| + \left(\frac{1}{C} - \varepsilon\right)|\gamma| \text{ by the hypothesis on } \lambda \\ &= \frac{1}{C}|\gamma| \end{aligned}$$

□

This finishes the proof of proposition 6.3. Indeed :

Let  $0 < \varepsilon < \frac{1}{C}$  and  $1 - \frac{1}{C'}(\frac{1}{C} - \varepsilon) < \lambda < 1$ . The lemma 6.18 gives the existence of a primitive element  $\gamma$  and some  $\varepsilon$ -quasi-loops in  $\gamma$  which occupy at least a proportion  $\lambda$  of  $\gamma$  and then the lemma 6.19 ensures that  $d(\rho(\gamma)o, o) < \frac{1}{C}|\gamma|$ . But since  $\gamma$  is primitive (and cyclically reduced), the Bowditch hypothesis (combined with Lemma 5.2) states that  $\frac{1}{C}|\gamma| \leq d(\rho(\gamma)o, o)$ , which is a contradiction. □

# Chapter 7

## From uniform tubular neighborhoods and Bowditch's hypothesis for $\mathbb{F}_2$ to primitive-stability

This section is dedicated to finish the proof of theorem 1.2, that is that a Bowditch representation is primitive-stable. Pick once and for all a Bowditch representation  $\rho$ , with constants  $(C, D)$ . In the section 6, we prove the existence of a constant  $K > 0$  such that for all primitive elements  $\gamma \in \mathbb{F}_2$ , we have the inclusion  $\tau_\rho(L_\gamma) \subset N_K(\text{Axis}(\rho(\gamma)))$ . (Recall that  $L_\gamma$  denotes the geodesic generated by  $\gamma$  in the Cayley graph of  $\mathbb{F}_2$  and  $\text{Axis}(\rho(\gamma))$  the axis of the hyperbolic isometry  $\rho(\gamma)$ .) For every  $\gamma$  in  $\mathcal{P}(\mathbb{F}_2)$ , pick  $\ell_\gamma$  some geodesic joining the two attracting and repelling point of  $\rho(\gamma)$ ,  $\rho(\gamma)^+$  and  $\rho(\gamma)^-$ . Then  $\ell_\gamma \subset \text{Axis}(\rho(\gamma))$  and by Lemma 6.1, there exists a constant  $C(\delta)$  such that  $N_K(\text{Axis}(\rho(\gamma))) \subset N_{K+C(\delta)}(\ell_\gamma)$ . Then, noting  $K_\delta = K + C(\delta)$ , we obtain that for all primitive elements  $\gamma \in \mathbb{F}_2$ , we have  $\tau_\rho(L_\gamma) \subset N_{K_\delta}(\ell_\gamma)$ .

Let  $p_o$  be some projection of the basepoint  $o$  on  $\ell_\gamma$ . For a point  $p$  on the geodesic  $\ell_\gamma$ , we define the real  $H_\gamma(p) = \pm d(p, p_o)$ . The sign plus or minus is determined according to which side of  $p_o$  the point  $p$  is located on. Thus  $H_\gamma$  is an isometry between  $\ell_\gamma$  and  $\mathbb{R}$  sending  $p_o$  to 0.

We begin by the following lemma :

**Lemma 7.1.** *Let  $\gamma$  be a primitive element in  $\mathbb{F}_2$  and pick an integer  $0 \leq i \leq r(\gamma)$ . Let  $g, g'$  and  $g''$  be three points on  $L_\gamma$ , aligned in this order, such that  $d(g, g') = d(g', g'') = l_i(\gamma)$  (hence  $d(g, g'') = 2l_i(\gamma)$ ). Denote  $x = \rho(g)o, x' = \rho(g')o, x'' = \rho(g'')o$  and choose  $p, p'$  and  $p''$  respectively projections of  $x, x'$  and  $x''$  on the geodesic  $\ell_\gamma$ .*

*Suppose that  $l_i(\gamma) > C(4C' + 24\delta + 2K_\delta + D)$ , then  $p, p'$  and  $p''$  are aligned in this order on  $\ell_\gamma$ .*

*Proof.* We prove this lemma by contraposition. Suppose that the points are aligned in one of the two following orders :  $p, p'', p'$  or  $p'', p, p'$ . Then the reals  $H_\gamma(p') - H_\gamma(p)$  and  $H_\gamma(p'') - H_\gamma(p')$  are of opposite signs. Without loss of generality, suppose that  $H_\gamma(p) \leq H_\gamma(p')$  and  $H_\gamma(p') \geq H_\gamma(p'')$ . Now consider all the integer points on the segment  $[g, g'']$  :  $g_0 = g, g_1, \dots, g_{l_i(\gamma)} = g', g_{l_i(\gamma)+1}, \dots, g_{2l_i(\gamma)} = g''$ . For  $0 \leq j \leq 2l_i(\gamma)$ , denote  $x_j = \rho(g_j)o$  and choose  $p_j$  a projection of  $x_j$  on  $\ell_\gamma$  (choose  $p_0 = p, p_{l_i(\gamma)} = p'$  and  $p_{2l_i(\gamma)} = p''$ ). Therefore, because of our hypothesis on  $p, p'$  and  $p''$ , there exists  $0 \leq j \leq l_i(\gamma) - 1$

such that,  $H(p_j) \leq H(p_{j+l_i(\gamma)})$  and  $H(p_{j+1}) \geq H(p_{j+l_i(\gamma)+1})$ . Hence :

$$\begin{aligned}
d(p_j, p_{j+l_i(\gamma)}) &= H(p_{j+l_i(\gamma)}) - H(p_j) && \text{because } H(p_j) \leq H(p_{j+l_i(\gamma)}) \\
&= H(p_{j+l_i(\gamma)}) - H(p_{j+l_i(\gamma)+1}) + H(p_{j+l_i(\gamma)+1}) - H(p_{j+1}) + H(p_{j+1}) - H(p_j) \\
&\leq |H(p_{j+l_i(\gamma)}) - H(p_{j+l_i(\gamma)+1})| + |H(p_{j+1}) - H(p_j)| && \text{because } H(p_{j+l_i(\gamma)+1}) - H(p_{j+1}) \leq 0 \\
&= d(p_{j+l_i(\gamma)}, p_{j+l_i(\gamma)+1}) + d(p_{j+1}, p_j) \\
&\leq d(\rho(g_{j+l_i(\gamma)})o, \rho(g_{j+l_i(\gamma)+1})o) + 12\delta + d(\rho(g_{j+1})o, \rho(g_j)o) + 12\delta && \text{by Lemma 2.5} \\
&\leq 2C' + 24\delta && \text{because } d(g_{j+l_i(\gamma)}, g_{j+l_i(\gamma)+1}) = d(g_j, g_{j+1}) = 1.
\end{aligned}$$

But since  $d(g_j, g_{j+l_i(\gamma)}) = l_i(\gamma)$ , we have, by the Bowditch hypothesis and the Proposition 4.6, the inequality :

$$\frac{1}{C}l_i(\gamma) - D \leq d(\rho(g_j)o, \rho(g_{j+l_i(\gamma)})o) + 2C'$$

Now recall that we have proven that  $\tau_\rho(L_\gamma)$  remains in the  $K_\delta$ -neighborhood of  $\ell_\gamma$ , then we have

$$d(\rho(g_j)o, \rho(g_{j+l_i(\gamma)})o) \leq d(p_j, p_{j+l_i(\gamma)}) + 2K_\delta.$$

Thus, we can bound  $l_i(\gamma)$  :

$$l_i(\gamma) \leq C(2C' + 24\delta + 2K_\delta + 2C' + D)$$

and this finishes the proof.  $\square$

We are now ready to prove that  $\rho$  is primitive-stable. By contradiction, suppose that it is not. Then for all  $n \in \mathbb{N}$ , we can find a cyclically reduced primitive element  $\gamma_n$  and two points  $g_n$  and  $h_n$  on  $L_{\gamma_n}$  such that  $d(\rho(g_n)o, \rho(h_n)o) \leq \frac{1}{n}d(g_n, h_n) - 1$ . Let  $x_n = \rho(g_n)o$  and  $y_n = \rho(h_n)o$ . We have that  $d(g_n, h_n) \geq n$ .

We can make the assumption that the elements  $\gamma_n$  are pairwise distinct. Indeed, if the sequence  $(\gamma_n)_n$  only takes finitely many values, then, up to subsequence, we can suppose that  $\gamma_n = \gamma$  for some primitive element  $\gamma$ . But  $\rho(\gamma)$  is an hyperbolic isometry so there exist two constants  $C_\gamma$  and  $D_\gamma$  (depending on  $\gamma$  !) such that  $\tau_\rho(L_\gamma)$  is a  $(C_\gamma, D_\gamma)$ -quasi-geodesic. Then, since  $g_n$  and  $h_n$  belong to  $L_\gamma$ , we have :

$$\begin{aligned}
\frac{1}{C_\gamma}d(g_n, h_n) - D_\gamma &\leq d(\rho(g_n)o, \rho(h_n)o) \leq \frac{1}{n}d(g_n, h_n) - 1 \\
\text{so } \frac{1}{C_\gamma} - \frac{D_\gamma}{d(g_n, h_n)} &\leq \frac{1}{n} - \frac{1}{d(g_n, h_n)},
\end{aligned}$$

then, taking the limit when  $n \rightarrow \infty$ ,  $\frac{1}{C_\gamma} \leq 0$ , which is absurd.

Thus we can suppose that the elements  $\gamma_n$  are pairwise distinct and therefore  $|\gamma_n| \rightarrow \infty$ . Denote by  $[N_1(\gamma_n), \dots, N_r(\gamma_n)(\gamma_n)]$  the continued fraction expansion of  $\gamma_n$ . As in the proof of the previous section (6), we can prove the following lemma.

**Lemma 7.2.** *For all  $i \in \mathbb{N}^*$ , there exists a constant  $C_i > 0$  such that for all  $n \in \mathbb{N}^*$ , whenever  $N_i(\gamma_n)$  is well defined (that is  $r(\gamma_n) \geq i$ ), we have  $N_i(\gamma_n) \leq C_i$ . Moreover, up to subsequence,  $r(\gamma_n) \rightarrow \infty$ .*

*Proof.* See proof of Lemma 6.5. □

Now fix an increasing map  $\psi : \mathbb{N}^* \rightarrow \mathbb{R}_+^*$  satisfying  $1 \leq \psi(n) \leq n$ ,  $\forall n \in \mathbb{N}^*$ ;  $\psi(n) \xrightarrow{n \rightarrow \infty} +\infty$  and  $\psi(n) = o(n)$  (for example, take  $\psi(n) = \sqrt{n}$ ). We set  $X_n := \{0 \leq i \leq r(\gamma_n) : l_i(\gamma_n) \leq \psi(n)\}$ . For  $n \geq 1$ ,  $X_n$  is non-empty because we always have  $0 \in X_n$ . Thus the integer  $I_n = \max X_n$  is well-defined.

**Lemma 7.3.** *Up to subsequence,  $I_n \xrightarrow{n \rightarrow \infty} +\infty$ . Moreover,  $l_{I_n} \xrightarrow{n \rightarrow \infty} +\infty$ .*

*Proof.* If the sequence  $(I_n)_n$  was to be bounded, let us fix  $I$  an integer such that  $I_N \leq I$  for all  $n \in \mathbb{N}^*$ . By the lemma 7.2,  $r(\gamma_n) \xrightarrow{n \rightarrow \infty} +\infty$  then for  $n$  sufficiently large,  $r(\gamma_n) \geq I + 1$ . Therefore, using again lemma 7.2 and up to passing to subsequence, we can assume that there exists  $N_1, \dots, N_I$  some positive integers such that for all  $1 \leq j \leq I$ ,  $N_j(\gamma_n) = N_j$ . As a consequence, the sequence  $(l_I(\gamma_n))_{n \in \mathbb{N}^*}$  is constant, and we denote  $l_I = l_I(\gamma_n)$ . Therefore we have for all  $n \in \mathbb{N}^*$ ,  $l_I \leq \psi(n) \leq l_{I+1}(\gamma_n)$ , so  $l_{I+1}(\gamma_n) \xrightarrow{n \rightarrow \infty} +\infty$ . But

$$l_{I+1}(\gamma_n) = (N_{I+1}(\gamma_n) - 1)l_I + l'_I \leq (N_{I+1}(\gamma_n) + 1)l_I$$

so we deduce that  $N_{I+1}(\gamma_n) \xrightarrow{n \rightarrow \infty} +\infty$ , contradicting the lemma 7.2.

The fact that  $l_{I_n} \rightarrow \infty$  is now immediate knowing that  $l_{I_n} \geq I_n + 1$  (see the inequalities of remark 4.4). □

Now consider the segment  $[g_n, h_n]$  in  $L_{\gamma_n}$  and let us cut it out in subsegments of length  $l_{I_n}$ , except maybe the last segment that must be of length smaller than  $l_{I_n}$ . Precisely, consider the Euclidean division of the integer  $d(g_n, h_n)$  by  $l_{I_n}$  :  $d(g_n, h_n) = q_n l_{I_n} + r_n$ , with  $0 \leq r_n < l_{I_n}$ , and set  $g_{0,n} = g_n, g_{1,n}, \dots, g_{q_n,n}$  points on  $L_{\gamma_n}$  such that  $d(g_{k,n}, g_{k+1,n}) = l_{I_n}$ ,  $d(g_{q_n,n}, h_n) = r_n \leq l_{I_n}$ . Moreover, since  $l_{I_n} \leq \psi(n) \leq \psi(d(g_n, h_n)) \leq d(g_n, h_n)$ , we conclude that  $q_n \geq 1$ . Now consider  $x_{k,n} = \rho(g_{k,n})o$  for  $0 \leq k \leq q_n$  the corresponding point in  $X$  and finally  $p_{k,n} = p(x_{k,n})$  its projection on  $\ell_{\gamma_n}$ , a geodesic joining the attracting and repelling points of  $\rho(\gamma_n)$ . On one hand, we have the following inequalities :

$$\begin{aligned} d(x_{0,n}, x_{q_n,n}) &\leq d(x_{0,n}, y_n) + d(y_n, x_{q_n,n}) && \text{by the triangle inequality} \\ &\leq d(x_n, y_n) + d(\rho(h_n)o, \rho(g_{q_n,n})o) && \text{by the definitions of } x_{0,n}, x_{q_n,n} \\ &\leq \frac{1}{n}d(g_n, h_n) - 1 + d(\rho(h_n)o, \rho(g_{q_n,n})o) && \text{by hypothesis on the points } g_n \text{ and } h_n \\ &\leq \frac{1}{n}d(g_n, h_n) - 1 + C'd(g_{q_n,n}, h_n) && \text{because } \tau_\rho \text{ is } C' \text{-Lipschitz-continuous} \\ &\leq \frac{1}{n}d(g_n, h_n) - 1 + C'l_{I_n} && \text{since } d(g_{q_n,n}, h_n) = r_n \leq l_{I_n}. \end{aligned}$$

On the other hand, since  $x_{0,n}$  and  $x_{q_n,n}$  belong to  $N_{K_\delta}(\ell_{\gamma_n})$ , we have that :

$$d(p_{0,n}, p_{q_n,n}) \leq d(x_{0,n}, x_{q_n,n}) + 2K_\delta$$

and by Lemma 7.1,  $p_{0,n}, p_{1,n}, \dots, p_{q_n,n}$  are aligned in this order on  $l_{\gamma_n}$ , hence

$$d(p_{0,n}, p_{q_n,n}) = \sum_{k=1}^{q_n} d(p_{k-1,n}, p_{k,n})$$

Combining Proposition 4.6 and the Bowditch hypothesis :

$$\begin{aligned} \frac{1}{C} l_{I_n} - D &\leq d(\rho(g_{i-1,n})o, \rho(g_{i,n})o) + 2C', \forall 1 \leq i \leq q_n \\ &= d(x_{i-1,n}, x_{i,n}) + 2C', \forall 1 \leq i \leq q_n \\ &\leq d(p_{i-1,n}, p_{i,n}) + 2K_\delta + 2C', \forall 1 \leq i \leq q_n \end{aligned}$$

Therefore, by summing :

$$\begin{aligned} \frac{q_n}{C} l_{I_n} - D q_n &\leq \sum_{i=1}^{q_n} d(p_{i-1,n}, p_{i,n}) + q_n(2K_\delta + 2C') \\ \frac{q_n}{C} l_{I_n} &\leq \sum_{i=1}^{q_n} d(p_{i-1,n}, p_{i,n}) + q_n(D + 2K_\delta + 2C') \\ &\leq d(x_{0,n}, x_{q_n,n}) + 2K_\delta + q_n(D + 2K_\delta + 2C') \\ &\leq \frac{1}{n} d(g_n, h_n) - 1 + C' l_{I_n} + 2K_\delta + q_n(D + 2K_\delta + 2C') \end{aligned}$$

Dividing by  $q_n l_{I_n}$  :

$$\frac{1}{C} \leq \frac{1}{n} \frac{d(g_n, h_n)}{q_n l_{I_n}} + \frac{D + 2K_\delta + 2C'}{l_{I_n}} + \frac{C'}{q_n} + \frac{2K_\delta - 1}{q_n l_{I_n}} \quad (7.1)$$

We now verify that the right hand side on this last inequality tends to zero :

- $l_{I_n} \rightarrow \infty$  by Lemma 7.3.
- We deduce that  $q_n l_{I_n} \rightarrow \infty$  because  $q_n \geq 1$ .
- $q_n = \frac{d(g_n, h_n) - r_n}{l_{I_n}} \geq \frac{d(g_n, h_n)}{l_{I_n}} - 1 \geq \frac{n}{\psi(n)} - 1 \rightarrow \infty$  because  $\psi(n) = o(n)$ .
- $\frac{d(g_n, h_n)}{q_n l_{I_n}} \leq \frac{(q_n + 1) l_{I_n}}{q_n l_{I_n}} = 1 + \frac{1}{q_n} \rightarrow 1$  because  $q_n \rightarrow \infty$ .

Therefore, taking the limit of the inequality 7.1, we obtain :  $\frac{1}{C} \leq 0$  which is absurd. Then the representation  $\rho$  is primitive-stable.

## Part II

# The four-punctured sphere



## Outline of Part II

The goal of this second part of the thesis is to prove Theorem 1.4. Notice that since we showed in section 3.1 the inclusion  $\mathcal{PS}(\pi_1(S_{0,4}), X) \subset \mathcal{BQ}(\pi_1(S_{0,4}), X)$ , we now need to prove the reverse inclusion, which is the most difficult one.

In Chapter 8, we will develop the necessary material and some crucial lemmas about the structure of simple closed curves in  $\pi_1(S_{0,4})$ . We will identify the four-punctured sphere with a quotient of the plane  $\mathbb{R}^2$  minus the lattice  $\mathbb{Z}^2$  in order to see the simple closed curves as quotient of straight lines with rational slope in  $\mathbb{R}^2$ . In particular, we will obtain a (bijective) correspondence between rational numbers and equivalence classes of simple closed curves on the four-punctured sphere (Proposition 8.1). Again we call the rational number associated to a simple closed curve  $\gamma$  its *slope* and its continued fraction expansion  $[n_1, \dots, n_r]$  will be of particular interest. Hence in section 8.3, we will try to understand the combinatorics of a simple closed curve  $\gamma$  at different scales, corresponding to each level  $i$  in the continued fraction expansion of the slope of  $\gamma$  (that is each integer  $0 \leq i \leq r$ ). In particular, Lemma 8.8 will decompose a simple closed curve  $\gamma$ , seen as a word in  $\pi_1(S_{0,4})$ , for each level  $i$  as a concatenation of words which will only depend on the integers  $n_1, \dots, n_i$ . Then, the rest of this Chapter will be dedicated to the statement and the proof of the "Magic-lengths" Proposition (8.16), which will be a major tool for our proof of Theorem 1.4. Our approach will be geometric, and so in section 8.4 we will first need to introduce some generalities about tilings of  $\mathbb{R}^2$  adapted to a lattice of  $\mathbb{R}^2$ , set up our notations and state a few facts needed in the following. Then section 8.5 will provide a short reminder about *Farey neighbours*. After these preliminaries, we will state the "Magic-lengths" Proposition (8.16) in section 8.6 : take  $\gamma$  a simple closed curve and  $w$  a subword of  $\gamma$  of length  $l_i(\gamma) - 5$  (where  $l_i(\gamma)$  will only depend on  $[n_1, \dots, n_i]$ ), then we can find a uniformly bounded from below proportion of the word  $\gamma$  consisting only of occurrences of the words  $w$  and  $w^{-1}$ . This will highlight the redundancy of subwords of some special lengths of  $\gamma$ . The proof will start by associating to every simple closed curve  $\gamma$  and every level  $1 \leq i \leq r$  of the continued fraction expansion of the slope of  $\gamma$  a lattice  $\Lambda$  of  $\mathbb{R}^2$  (section 8.6.1). This lattice will be particularly useful to understand the word  $\gamma$  at the level  $i$  : within this geometric framework we can "read" the word  $\gamma$  in  $\mathbb{R}^2$  by following an horizontal line and the subwords of lengths approximately  $l_i(\gamma)$  will be easier to visualise and to understand (section 8.6.2 and 8.6.3). Finally section 8.6.4 will combine the results on lattices in  $\mathbb{R}^2$  of section 8.4 with our study of subwords of  $\gamma$  of length approximately  $l_i(\gamma)$  in section 8.6.2 and 8.6.3 to prove Proposition 8.16.

Now the rest of Part II will follow the same paths as in the case of the free group of rank two (Part I). However, since the combinatorics of simple closed curves on the four-punctured sphere is different and more complicated than the combinatorics of primitive elements in  $\mathbb{F}_2$ , the statements and their proofs have to be adapted. Thus, for completeness of this outline, we would like to remind the reader of the main steps and ideas of the rest of the proof.

In section 9.1 of Chapter 9, we will study an other uniform quasi-geodesicity setting which will later appear as a local uniform quasi-geodesicity property of Bowditch representations of  $\pi_1(S_{0,4})$ .



In section 9.2, we will show two properties on Bowditch representations. The first one will state that the images of simple elements under a Bowditch representation are always hyperbolic (Lemma 9.2). In particular, denoting  $L_\gamma$  the axis of  $\gamma$  in the Cayley graph of  $\pi_1(S_{0,4})$  and  $\tau_\rho$  the orbit map of a Bowditch representation  $\rho$ , we deduce that  $\tau_\rho(L_\gamma)$  is always a quasi-geodesic. The second property (Lemma 9.3) will ensure that the hypothesis required by Proposition 9.1 on the isometries of the proposition is satisfied when the isometries comes from a Bowditch representation of  $\pi_1(S_{0,4})$ .

Finally Chapters 10 and 11 will be dedicated to proving that a Bowditch representation of  $\pi_1(S_{0,4})$  is simple-stable. In Chapter 10, we will first prove a slightly weaker statement (Proposition 10.1), which will be the main step for proving Theorem 1.4. It states that the images of the simple leaves  $L_\gamma$  by the orbit map stay in a uniformly bounded neighborhood of the axes of the simple elements  $\gamma$ . At last, Chapter 11 will conclude the proof by showing that a Bowditch representation of  $\pi_1(S_{0,4})$  satisfying the conclusion of Proposition 10.1 is simple-stable.

Let us now detail the strategy of the proof of Proposition 10.1. We fix a Bowditch representation  $\rho$  of  $\pi_1(S_{0,4})$  and we want to show that the image of the orbit map restricted to simple leaves is contained in a uniform tubular neighborhood of the axes of the images of the simple elements. We proceed by contradiction and to this purpose we introduce a sequence  $(\gamma_n)_{n \in \mathbb{N}}$  of simple elements in  $\pi_1(S_{0,4})$  such that the image of the orbit map on the simple leave  $L_{\gamma_n}$  becomes further and further away from the axis of  $\rho(\gamma_n)$  as  $n$  increases. We will now study the continued fraction expansion of the slope of  $\gamma_n$  which we denote by  $[N_1^n, \dots, N_{r(n)}^n]$ . The uniform quasi-geodesicity setting studied in Proposition 9.1 of Chapter 9, together with Lemma 9.3 and our hypothesis on  $(\gamma_n)_{n \in \mathbb{N}}$ , will enable us to deduce the behavior of the continued fraction expansion : the sequences  $(N_i^n)_n$  must be bounded for all  $i$ , and, as a consequence, the depth  $r(n)$  of the continued fraction expansion will tend to infinity (Lemma 10.2). In particular, for all  $i$ , we will obtain a uniform control on the lengths  $l_i(\gamma_n)$  previously defined in Chapter 8. We will next introduce the notion of a  $K$ -excursion of the orbit map (section 10.3) and show that we can extract from the sequence  $(\gamma_n)_{n \in \mathbb{N}}$  a sequence of  $K_n$ -excursions as large as we want ( $K_n \rightarrow \infty$ ) in Lemma 10.4. We will also define the notion of an  $\varepsilon$ -quasi-loop, and exactly as in the context of  $\mathbb{F}_2$ , large excursions will correspond to quasi-loop (Lemma 10.5). As a consequence, we will find a quasi-loop in each  $\gamma_n$  (for large  $n$ ). But we will be more precise and, using our *Magic-lengths* Proposition (8.16) together with the fact that once found a quasi-loop, we can find many others of smaller lengths "inside", we will find a uniformly bounded from bellow proportion of the word  $\gamma_n$  consisting of disjoint quasi-loops (Lemma 10.6). We will repeat our argument for the remainders in  $\gamma_n$  that do not yet consist of disjoint quasi-loops in order to find an arbitrarily large proportion of the word  $\gamma_n$  consisting of disjoint quasi-loops (Lemma 10.7). To formalise this idea we will use a recursive argument in the proof. This mean that we will find an arbitrarily large proportion of the word  $\gamma_n$  which does not displace the basepoint much, and this will be in contradiction with the Bowditch's hypothesis.

# Chapter 8

## Structure of simple closed curves on the four-punctured sphere

### 8.1 The four-punctured sphere

Let  $S_{0,4}$  be a (topological) four-punctured sphere, that is, a sphere with four distinct points removed.

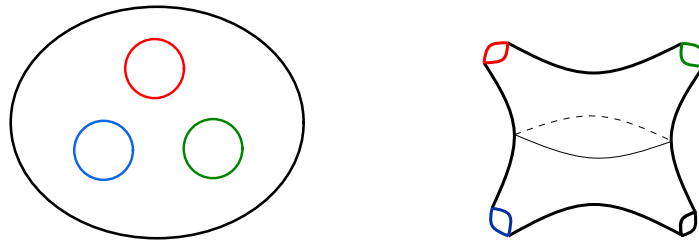

Figure 8.1: The four punctured-sphere  $S_{0,4}$

We will use the following model for  $S_{0,4}$ , and see it as the quotient of the plane minus a lattice in the following way :

$$S_{0,4} \simeq (\mathbb{R}^2 \setminus \mathbb{Z}^2) / \langle \{s_\lambda : \lambda \in \mathbb{Z}^2\} \rangle$$

where  $s_\lambda$  is the reflection of the plane across the point  $\lambda$  (hence we have the formula  $s_\lambda(u) = 2\lambda - u$ ). Moreover, it is not hard to check that this model is equivalent to the following one :

$$S_{0,4} \simeq (\mathbb{R}^2 \setminus \mathbb{Z}^2) / \langle 2\mathbb{Z}^2, \pm \rangle$$

The four punctures on the sphere are given by the four classes of points in  $\mathbb{Z}^2$  given by the action of  $2\mathbb{Z}^2$  on it. They are drawn in black, blue, green and red on figure 8.2. A fundamental domain is given in figure 8.3a by identifying the edges of the triangle as illustrated in the figure. We will refer to this triangle in the following as the fundamental triangle.

Finally, we can also see the sphere  $S_{0,4}$  as a quotient of the square  $[0, 2]^2 \setminus (\mathbb{Z}^2 \cap [0, 2]^2)$  in  $\mathbb{R}^2$  by

identifying the opposite sides of the square and applying the reflection across the center point of the square : (1, 1) (see figure 8.3b). In this last description, we recover the classical fact that the four-punctured sphere is the quotient of the torus minus 4 points by the hyper-elliptic involution.

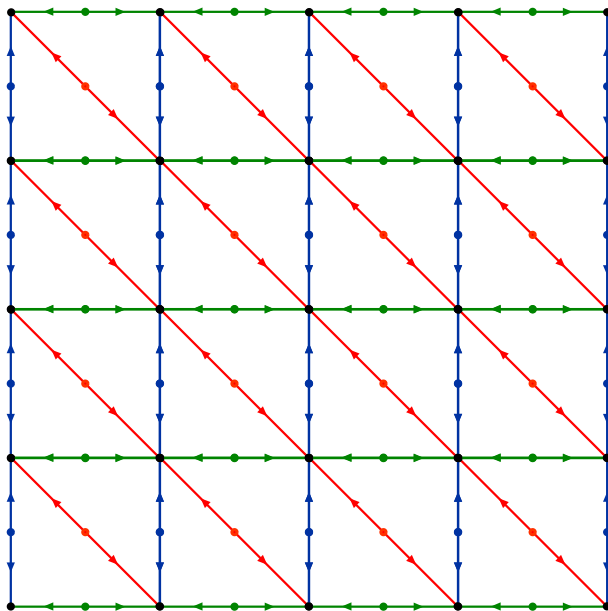

Figure 8.2: The sphere as the quotient of the plane :  
 $S_{0,4} \simeq (\mathbb{R}^2 \setminus \mathbb{Z}^2) / (2\mathbb{Z}^2, \pm)$

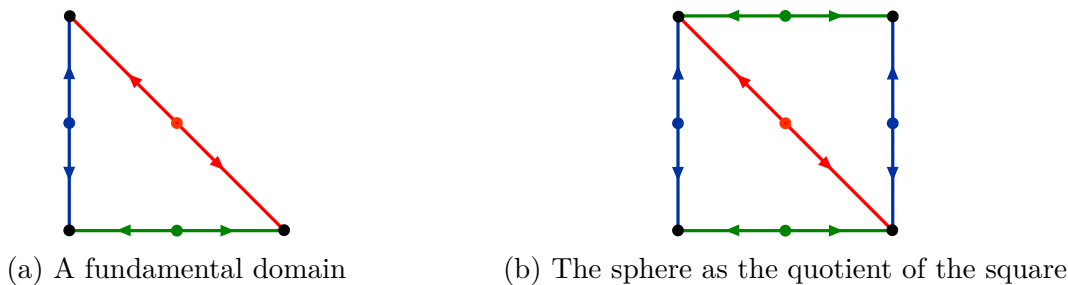

Figure 8.3: Fundamental triangle and square for  $S_{0,4}$

## 8.2 Simple closed curves on the four-punctured sphere

The fundamental group of the four-punctured sphere is the free group of rank three  $\mathbb{F}_3$ . We fix once and for all the following free generating set :  $\pi_1(S_{0,4}) = \mathbb{F}_3 = \langle a, b, c \rangle$ , with  $a, b$  and  $c$  the curves corresponding to three of the four boundary components of  $S_{0,4}$  as described in the picture 8.4. Note that with this convention of orientation, the element  $abc$  corresponds to the fourth boundary component (in black in the pictures).

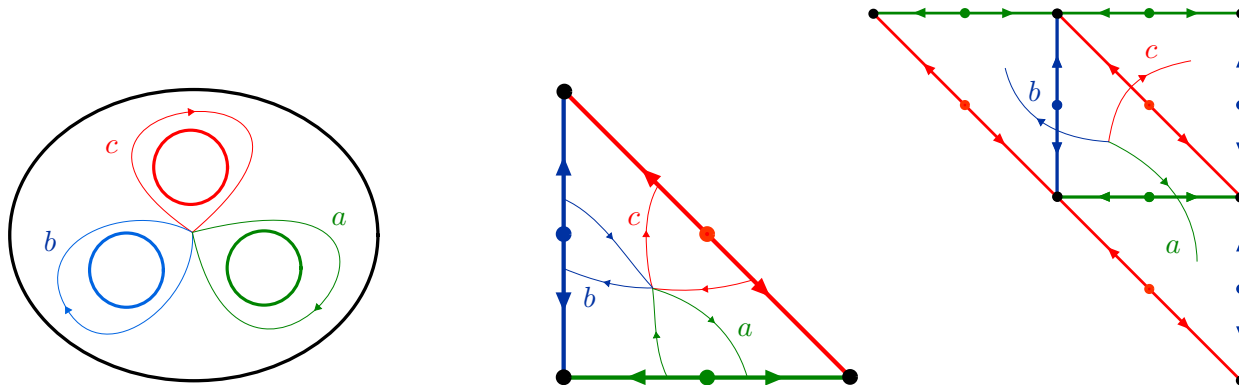

Figure 8.4: The three generators of  $\pi_1(S_{0,4}) = \mathbb{F}_3 = \langle a, b, c \rangle$ .

Denote by  $A, B$  and  $C$  the three edges of the fundamental triangle respectively containing the punctures represented by the homotopy class  $a, b$  and  $c$ . The puncture at the middle of each edge defines two half-edges. There is a total of six half-edges, on which we fix alternating transverse orientations (see figure 8.5). These transverse orientations are respected by the gluings. For every oriented curve  $\gamma$  on  $S_{0,4}$ , we can write the corresponding word in the fundamental group (up to cyclic permutation) by following the curve  $\gamma$  and writing the letter  $a, b$  or  $c$  respectively each time  $\gamma$  crosses the edge  $A, B$  or  $C$ , with power  $\pm 1$  depending on whether or not the orientation of  $\gamma$  at the intersection point agrees with the transverse orientation on the corresponding half-edge.

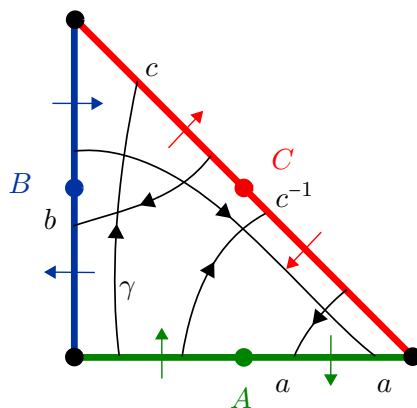

Figure 8.5: Reading the word  $\gamma = cac^{-1}ba$  in the fundamental triangle

Let us go back to the plane. We say that a point in  $\mathbb{Z}^2$  is of *type*  $a, b, c$  or  $abc$ , if its class mod  $2\mathbb{Z}^2$  corresponds to the puncture represented respectively by the homotopy class  $a, b, c$  or  $abc$  (hence a point is of *type*  $a, b, c$  or  $abc$ , if its class mod  $\mathbb{Z}^2$  is respectively  $(1, 0), (0, 1), (1, 1)$  or  $(0, 0)$ ). The points of *type*  $a, b, c$  or  $abc$  are exactly the lifts of the puncture represented respectively by  $a, b, c$  or  $abc$ . In our pictures, the points of *type*  $a$  are in green, the points of *type*  $b$  in blue, the points of *type*  $c$  in red and the points of *type*  $abc$  in black. We will keep this convention in all the following. Now let us denote by  $L_A$  the set of horizontal lines in the plane passing through a point of *type*  $a$ ,  $L_B$  the set of vertical lines in the plane passing through a point of *type*  $b$ , and  $L_C$  the set of lines

of slope  $-1$  in the plane passing through a point of type  $c$  (hence we have  $L_A = \{y = 2\lambda \mid \lambda \in \mathbb{Z}\}$ ,  $L_B = \{x = 2\lambda \mid \lambda \in \mathbb{Z}\}$  and  $L_C = \{y = -x + 2\lambda \mid \lambda \in \mathbb{Z}\}$ ). Then through a point of type  $a, b$  or  $c$  passes exactly one line in  $L_A \cup L_B \cup L_C$  whereas through a point of type  $abc$  pass exactly three lines in  $L_A \cup L_B \cup L_C$ : one in  $L_A$ , one in  $L_B$  and one in  $L_C$ . We say that a line  $l$  is of type  $a, b$  or  $c$  respectively if  $l \in L_A, l \in L_B$  or  $l \in L_C$ . Two different lines of the same type never intersect whereas two lines of two different types always intersect in a point of  $\mathbb{Z}^2$  of type  $abc$ . Moreover, each line in  $L_A, L_B$  and  $L_C$  is a union of segments (of the same lengths) with endpoints in  $\mathbb{Z}^2$  and with no point of  $\mathbb{Z}^2$  in the interior of the segments. The two endpoints of each segment are of two different types (one endpoint is of type  $t \in \{a, b, c\}$ , where  $t$  is the type of the line, and the other endpoint is of type  $abc$ ). Those segments correspond exactly to a half-edge in the fundamental triangle. Therefore, on each segment, we can put a transverse orientation which is just the lift of the orientation on the corresponding half-edge in the fundamental triangle.

Now we can play in the plane the same game as in the fundamental triangle and write, for a curve  $\gamma$  in  $S_{0,4}$ , the corresponding word in the fundamental group by following a lift  $\tilde{\gamma}$  of  $\gamma$  in  $\mathbb{R}^2 \setminus \mathbb{Z}^2$  and record  $a, b$  or  $c$  each time  $\tilde{\gamma}$  crosses a line in  $L_A, L_B$  or  $L_C$  and put a sign  $\pm 1$  depending on whether or not the orientation of  $\tilde{\gamma}$  at the intersection point coincides with the transverse orientation on the segment.

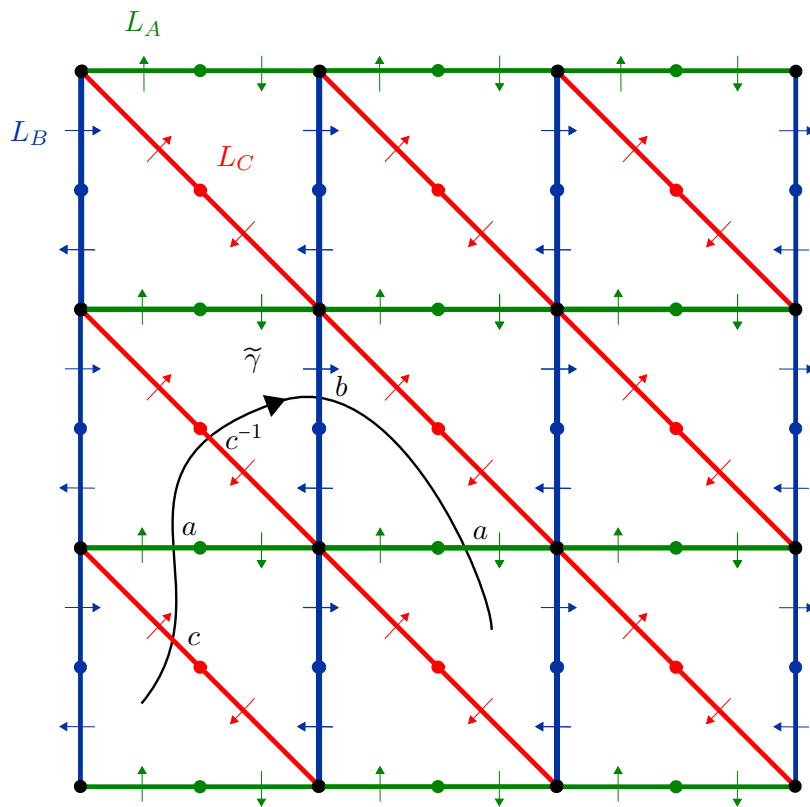

Figure 8.6: Reading the curve  $\gamma = cac^{-1}ba$  in the plane using the three sets of parallel lines  $L_A, L_B$  and  $L_C$

In the fundamental triangle, curves on  $S_{0,4}$  look like arcs joining the three edges  $A, B$  and  $C$  of

the triangle. Notice that since the two half-edges of an edge are identified by a reflection, if an arc has an endpoint in one half-edge, this forces another arc to have one of its endpoints in the other half-edge of the same edge, and those two endpoints must be reflected from each other across the midpoint of the edge. An arc can possibly join the same edge, but in this case it joins two different halves of the same edge, otherwise this arc would be trivial and could be removed by a homotopy of the curve (corresponding to a cancellation such as  $aa^{-1}$  in  $\gamma$ ).

Recall that, as defined in the introduction, we say that a closed curve  $\gamma$  on  $S_{0,4}$  is *simple* if there exists a representative of  $\gamma$  in its homotopy class which has no self-intersection and which does not bound a disk or a once-punctured disk, and we denote by  $\mathcal{S}(S_{0,4})$  the set of free homotopy classes of (unoriented) simple closed curves on  $S_{0,4}$ . With a slight abuse of notation, we will write  $\gamma \in \mathcal{S}(S_{0,4})$  to refer to a (cyclically reduced) word  $\gamma$  in the fundamental group  $\pi_1(S_{0,4})$  representing a simple closed curve in  $\mathcal{S}(S_{0,4})$ , thus identifying curves on the surface  $S_{0,4}$  and representatives in the fundamental group.

First notice that every line with rational slope in the plane (which avoids  $\mathbb{Z}^2$ ) gives a simple closed curve in the quotient. The converse is also true and is the main purpose of the following classical result :

**Proposition 8.1.** *Let  $\gamma$  be a simple closed curve on  $S_{0,4}$ . Then, after homotopy,  $\gamma$  can be lifted to a line of rational slope in the plane.*

*Therefore, there exists a well defined map  $\text{Slope} : \mathcal{S}(S_{0,4}) \rightarrow \mathbb{Q} \cup \infty$ , which is a bijection.*

*Proof.* Fix  $\gamma$  a simple closed curve on  $S_{0,4}$ . Let us look at  $\gamma$  as a collection of arcs in the fundamental triangle. This collection of arcs does not intersect, because the curve is assumed to be simple. By a slight abuse of notation, also denote by  $\gamma$  the corresponding cyclically reduced word in the fundamental group. We are going to prove the following facts :

- **Fact 1** : Every letter in  $\gamma$  is isolated.

It suffices to show that if a word contains the pattern  $\dots s^2 \dots$ , with  $s \in \{a, a^{-1}, b, b^{-1}, c, c^{-1}\}$ , then the corresponding curve contains self-intersection. It is easy to see that the presence of  $s^2$  in the word forces the existence of an arc  $\beta$  from an edge  $e$  of the fundamental triangle to itself, starting and ending in two different half-edges of  $e$ . Suppose  $\beta$  is an innermost such arc. Then another arc (the next one or the previous one when following the curve) has an endpoint on  $e$ , in between the two endpoints of  $\beta$ . But since this new arc is not innermost, it has to "escape" the region bordered by  $\beta \cup e$ . This would create self-intersection.

- **Fact 2** : There is an edge of the fundamental triangle such that every arc has an endpoint on it.

We deduce from the previous fact that there is no arc joining an edge to itself. Note that the only case which is not covered by the previous fact is when  $\gamma$  has a single arc from an edge to itself, but in this case, this would mean that  $\gamma$  is in fact  $a, b$  or  $c$ , hence a boundary curve, which is not possible because  $\gamma$  is a simple curve (and then it is supposed to be non-peripheral). In other words, all the arcs join different edges. Suppose that any two distinct

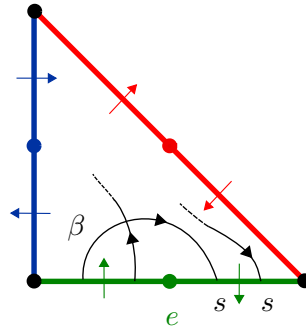

Figure 8.7: The pattern  $\dots s^2 \dots$  forces intersection. (Here  $e = A, s = a$ ).

edges are joined by at least an arc. Under this assumption, consider for every pair of distinct edges of the fundamental triangle the innermost arc joining those two edges, that is, the arc whose two endpoints are the closest to the intersection point between the two edges (which is the puncture  $abc$ ). Then these three arcs combine together to form the boundary curve  $abc$ . We now deduce of this observation that these three arcs form a connected component of  $\gamma$ , which is taken simple (hence connected), so there is no other arc in  $\gamma$ . Therefore  $\gamma = abc$  (up to cyclic permutation and inversion) which is not possible because  $\gamma$  is supposed to be non-peripheral and  $abc$  is a boundary curve.

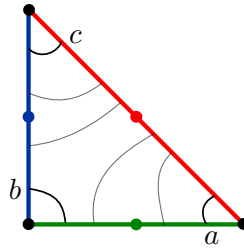

Figure 8.8: The three arcs in black together form the boundary component  $abc$ .

- **Fact 3 :** The curve  $\gamma$  is uniquely determined by its intersection numbers with the three edges  $A, B$  and  $C$ .

Denote by  $n_A, n_B$  and  $n_C$  the numbers of intersection between the curve  $\gamma$  and the three edges  $A, B$  and  $C$ . First notice that since the two half-edges of an edge are identified, the three integers  $n_A, n_B$  and  $n_C$  must be even. Then, remark that these numbers are also the number of arcs having an endpoint on  $A, B$  and  $C$ . By fact 2, we know that there exists an edge such that every arc has an endpoint on it. Hence we deduce that either  $n_C = n_A + n_B$ , or  $n_B = n_A + n_C$  or  $n_A = n_B + n_C$ . Without loss of generality, let us now suppose that  $n_C = n_A + n_B$ . In this case, every intersection point on  $C$  must be linked by an arc to an intersection point on  $A \cup B$ . There is only one way of pairing intersection points on  $C$  and on  $A \cup B$  without creating self-intersection, and this determines the curve  $\gamma$ .
- **Fact 4 :** After homotopy, the curve  $\gamma$  can be lifted to a simple closed curve on the torus  $\mathbb{R}^2/2\mathbb{Z}^2$ .

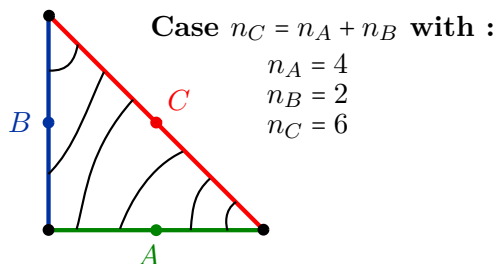

Figure 8.9: Pairing the endpoints on the edge  $C$  with the endpoints on the edge  $A \cup B$ .

Suppose that we are in the case where  $n_C = n_A + n_B$  (exchange the role of  $A, B$  and  $C$  for the other cases). Now consider the triangle obtained as a reflection of the fundamental triangle across the center point of the edge  $C$ . The union of the two triangles forms a square with the opposite sides identified, thus a torus. Let us justify that any lift of the curve  $\gamma$  in the torus is a simple closed curve on the torus. Choose a basepoint  $x$  on the curve  $\gamma$ , then it has two lifts on the torus, one in each triangle, and let us choose one,  $\tilde{x}$ . Notice that by following the curve  $\gamma$  from  $x$ , its lift  $\tilde{\gamma}$  from  $\tilde{x}$  changes triangle each time  $\gamma$  meets an edge of the fundamental triangle. This happens exactly  $\frac{n_A}{2} + \frac{n_B}{2} + \frac{n_C}{2}$  times, and since  $\frac{n_A}{2} + \frac{n_B}{2} + \frac{n_C}{2} = n_C$  is even, this means that the endpoint of  $\tilde{\gamma}$  lies in the same triangle as  $\tilde{x}$ , therefore is  $\tilde{x}$ . Thus the lift  $\tilde{\gamma}$  is a closed curve, and it is simple because  $\gamma$  is. Finally, the intersection numbers between the lift  $\tilde{\gamma}$  of the curve  $\gamma$  and the sides of the square are given by the numbers  $\frac{n_A}{2}, \frac{n_B}{2}$ . Therefore,  $\frac{n_A}{2}$  and  $\frac{n_B}{2}$  are relatively prime and  $\gamma$  can be lifted to a line of slope  $\frac{n_A}{n_B}$  in the plane. This allows us to define the map Slope from  $\mathcal{S}(S_{0,4})$  to  $\mathbb{Q} \cup \infty$ , such that  $\text{Slope}(\gamma) = \frac{n_A}{n_B}$ .

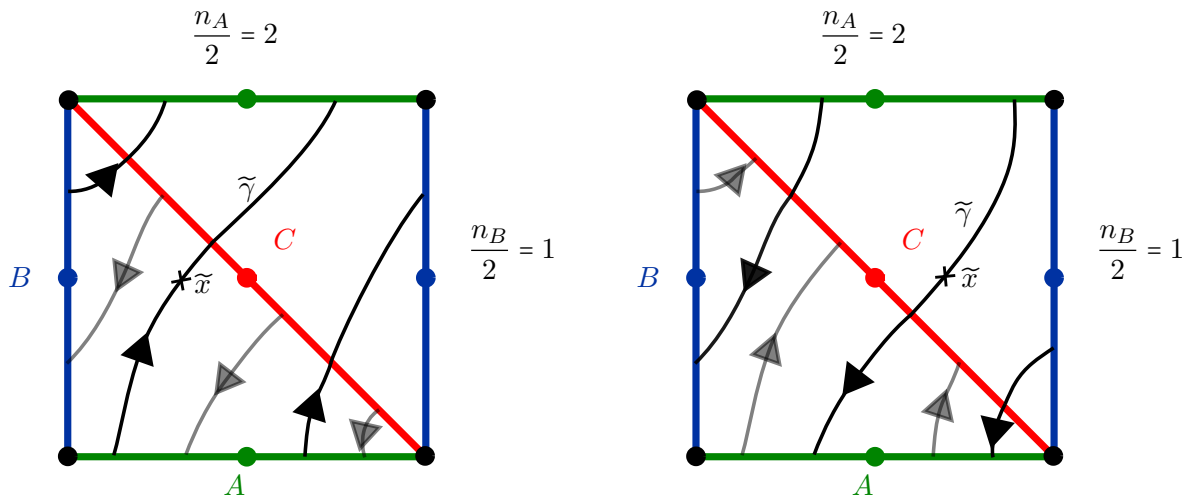

Figure 8.10: The two lifts (in black) of the curve  $\gamma$  (in black and grey) in the torus.

□

*Remark 8.2.* The proof of the previous proposition allows us to have a better understanding of simple closed curves in  $S_{0,4}$ . We deduce the following :

Let  $\gamma \in \mathcal{S}(S_{0,4})$ . Then, if  $\gamma$  is cyclically reduced, one out of two letters in  $\gamma$  is, up to inversion, always the same.



- If this letter is  $c$ , then  $\text{Slope}(\gamma) \in [0, \infty]$ . Moreover, consider the map  $\varphi$  from  $\mathbb{F}_3$  to  $\mathbb{F}_2$  such that  $\varphi(c) = \varphi(c^{-1}) = 1$ ,  $\varphi(a) = \varphi(a^{-1}) = a$ ,  $\varphi(b) = \varphi(b^{-1}) = b$  and  $\varphi(u) = \varphi(s_1) \cdots \varphi(s_p)$ , where  $u = s_1 \cdots s_p$ , with  $s_i \in \{a, a^{-1}, b, b^{-1}, c, c^{-1}\}$ , is cyclically reduced. Then  $\varphi(\gamma)$  is a primitive element of  $\mathbb{F}_2$  and its slope as an element in  $\mathbb{F}_2$  is the same as the slope of  $\gamma$  :  $\text{Slope}(\gamma) = \text{Slope}(\varphi(\gamma))$ .
- If this letter is  $a$ , then  $\text{Slope}(\gamma) \in [-\infty, -1]$ . Moreover, consider the map  $\varphi$  from  $\mathbb{F}_3$  to  $\mathbb{F}_2$  such that  $\varphi(c) = \varphi(c^{-1}) = 1$ ,  $\varphi(a) = \varphi(a^{-1}) = a^{-1}$ ,  $\varphi(b) = \varphi(b^{-1}) = b$  and  $\varphi(u) = \varphi(s_1) \cdots \varphi(s_p)$ , where  $u = s_1 \cdots s_p$ , with  $s_i \in \{a, a^{-1}, b, b^{-1}, c, c^{-1}\}$ , is cyclically reduced. Then  $\varphi(\gamma)$  is a primitive element of  $\mathbb{F}_2$  and its slope as an element in  $\mathbb{F}_2$  is the same as the slope of  $\gamma$  :  $\text{Slope}(\gamma) = \text{Slope}(\varphi(\gamma))$ .
- If this letter is  $b$ , then  $\text{Slope}(\gamma) \in [-1, 0]$ . Moreover, consider the map  $\varphi$  from  $\mathbb{F}_3$  to  $\mathbb{F}_2$  such that  $\varphi(c) = \varphi(c^{-1}) = 1$ ,  $\varphi(a) = \varphi(a^{-1}) = a^{-1}$ ,  $\varphi(b) = \varphi(b^{-1}) = b$ , where  $u = s_1 \cdots s_p$ , with  $s_i \in \{a, a^{-1}, b, b^{-1}, c, c^{-1}\}$ , is cyclically reduced. Then  $\varphi(\gamma)$  is a primitive element of  $\mathbb{F}_2$  and its slope as an element in  $\mathbb{F}_2$  is the same as the slope of  $\gamma$  :  $\text{Slope}(\gamma) = \text{Slope}(\varphi(\gamma))$ .

*Remark 8.3.* Notice that the map  $\text{Slope}$  depends on the choice of a basis  $\{a, b, c\}$  for  $\pi_1(S_{0,4}) = \mathbb{F}_3$ . The choice of another basis leads to another map  $\text{Slope}$ . However, we can link the slope map of two different bases. Denote  $\text{Slope}_{a,b,c}$  the slope map in the basis  $\{a, b, c\}$ .

Let  $\gamma \in \mathcal{S}(S_{0,4})$  be such that  $\text{Slope}_{a,b,c}(\gamma) = [n_1, \dots, n_r]$ . Fix  $1 \leq i < r$  and let  $a', b', c'$  be another basis of  $\mathbb{F}_3$  such that  $\text{Slope}_{a,b,c}(c'b') = [n_1, \dots, n_i]$  and  $\text{Slope}_{a,b,c}(c'a') = [n_1, \dots, n_i + 1]$ . Then  $\text{Slope}_{a',b',c'}(\gamma) = [n_{i+1}, \dots, n_r]$ .

The  $\text{Slope}$  map only depends on the class of an element up to conjugacy and inversion. Therefore, for an element  $\varphi$  in the mapping class group  $\text{MCG}(S_{0,4})$ , even if the element  $\varphi(\gamma)$  is defined only up to conjugacy, the rational  $\text{Slope}(\varphi(\gamma))$  is well-defined.

**Lemma 8.4.** *Let  $\mathbb{F}_3 = \pi_1(S_{0,4}) = \langle a, b, c \rangle$ . Let  $\frac{p}{q}$  and  $\frac{p'}{q'}$  be two rational numbers such that  $|pq' - p'q| = 1$ . Then there exists a mapping class  $\varphi \in \text{MCG}(S_{0,4})$  such that  $\text{Slope}(\varphi(cb)) = \frac{p}{q}$  and  $\text{Slope}(\varphi(ca)) = \frac{p'}{q'}$ .*

*Proof.* First notice that the hypothesis  $|pq' - p'q| = 1$  means that the two vectors  $(q, p)$  and  $(q', p')$  of  $\mathbb{Z}^2$  form a basis of  $\mathbb{Z}^2$ . This implies that the matrix  $M = \begin{pmatrix} q & q' \\ p & p' \end{pmatrix}$  belongs to  $\text{SL}^\pm(2, \mathbb{Z})$ , so  $M$  preserve the lattice  $\mathbb{Z}^2$  inside  $\mathbb{R}^2$ . The action of  $(2\mathbb{Z}^2, \pm)$  on  $\mathbb{R}^2 \setminus \mathbb{Z}^2$  is  $M$  equivariant, so  $M$  induces a homeomorphism of the quotient  $(\mathbb{R}^2 \setminus \mathbb{Z}^2)/(2\mathbb{Z}^2, \pm)$ , which is the sphere  $S_{0,4}$ . The line  $l_x$  from  $x$  to  $x + (2, 0)$  in  $\mathbb{R}^2 \setminus \mathbb{Z}^2$  (here  $x$  is an arbitrary point in  $\mathbb{R}^2$  such that  $l_x$  avoids the lattice  $\mathbb{Z}^2$ ) induces a simple closed curve  $\gamma_{\frac{0}{1}}$  in  $S_{0,4}$  represented by  $cb$  in  $\pi_1(S_{0,4})$ . This line is sent by  $M$  to the line from  $M(x)$  to  $M(x) + 2(q, p)$  which induces a simple closed curve  $\gamma_{\frac{p}{q}}$  in  $S_{0,4}$  of slope  $\frac{p}{q}$ . Similarly, the line from  $x$  to  $x + (0, 2)$  in  $\mathbb{R}^2 \setminus \mathbb{Z}^2$  induces a simple closed curve  $\gamma_{\frac{1}{0}}$  in  $S_{0,4}$  represented by  $ca$  in  $\pi_1(S_{0,4})$ . This line is sent by  $M$  to the line from  $M(x)$  to  $M(x) + 2(q', p')$  which induces a simple closed curve  $\gamma_{\frac{p'}{q'}}$  in  $S_{0,4}$  of slope  $\frac{p'}{q'}$ . Hence  $\varphi = M_*$  is in the mapping class group of  $S_{0,4}$  and satisfies the conditions required by the lemma.  $\square$

## 8.3 Constructing simple closed curves

In this section, we try to have a better understanding of the structure of the elements of  $\mathcal{S}(S_{0,4})$ .

**Lemma 8.5.** *Let  $\gamma \in \mathcal{S}(S_{0,4})$ . Suppose that  $\text{Slope}(\gamma) \geq 0$ . Denote  $n = \lfloor \text{Slope}(\gamma) \rfloor \in \mathbb{N}$ . Then,*

- *If  $n$  is even,  $\gamma$  can be written (up to conjugation) as a concatenation of subwords of the form :*

$$\begin{aligned} w(\tilde{c}, \tilde{b}) &= (ca)^{\frac{n}{2}} \tilde{c} (ca)^{-\frac{n}{2}} \tilde{b} \\ w'(\tilde{c}, \tilde{b}, 0) &= (ca)^{\frac{n}{2}} \tilde{c} (ca)^{-\frac{n}{2}-1} \tilde{b} \\ w'(\tilde{c}, \tilde{b}, 1) &= (ca)^{\frac{n}{2}+1} \tilde{c} (ca)^{-\frac{n}{2}} \tilde{b} \end{aligned}$$

where  $\tilde{c} \in \{c, c^{-1}\}, \tilde{b} \in \{b, b^{-1}\}$ .

- *If  $n$  is odd,  $\gamma$  can be written (up to conjugation) as a concatenation of subwords of the form :*

$$\begin{aligned} w(\tilde{c}, \tilde{b}, 0) &= (ca)^{\frac{n-1}{2}} \tilde{c} (ca)^{-\frac{n+1}{2}} \tilde{b} \\ w(\tilde{c}, \tilde{b}, 1) &= (ca)^{\frac{n+1}{2}} \tilde{c} (ca)^{-\frac{n-1}{2}} \tilde{b} \\ w'(\tilde{c}, \tilde{b}) &= (ca)^{\frac{n+1}{2}} \tilde{c} (ca)^{-\frac{n+1}{2}} \tilde{b} \end{aligned}$$

where  $\tilde{c} \in \{c, c^{-1}\}, \tilde{b} \in \{b, b^{-1}\}$ .

Before starting the proof, recall that we can see the sphere  $S_{0,4}$  as the quotient of the square  $[0, 2]^2 \setminus (\mathbb{Z}^2 \cap [0, 2]^2)$  by the reflection across the center point of the square  $(1, 1)$ . In this description, two opposite sides of the square are identified (by a translation) and every side is identified with itself by a reflection across its midpoint. Moreover, the diagonal from  $(0, 2)$  to  $(2, 0)$  is identified with itself by a reflection across its midpoint. We can put a transverse orientation on each half-side and on the two half-diagonals as in figure 8.6 on page 92 or figure 8.11 on page 98. This orientation is just the lift of the orientation already chosen on the half-edges of the fundamental triangle.

Thus we can write the word in the fundamental group corresponding to a curve by following the curve and record an  $a$  each time it crosses a horizontal side of the square, with sign  $\pm 1$  depending on whether or not the orientation of the line coincides with the transverse orientation on the corresponding half-side, record a  $b$  each time the curve crosses a vertical side of the square, with sign  $\pm 1$  depending on whether or not the orientation of the curve coincides with the transverse orientation on the corresponding half-side, and record a  $c$  each time the curve crosses the diagonal from  $(0, 2)$  to  $(2, 0)$ , with sign  $\pm 1$  depending on whether or not the orientation of the curve coincides with the transverse orientation on the corresponding half-diagonal.

*Proof.* Consider a line of slope  $\frac{p}{q} = \text{Slope}(\gamma) \geq 0$  in the plane. We can assume that this line avoids the points of the lattice  $\mathbb{Z}^2$ . In the quotient by  $2\mathbb{Z}^2$ , this line is a collection of parallel segments of slope  $\frac{p}{q}$  joining two sides of the square. The identification between two opposite sides of the square gives an ordering on the segments. Now we want to understand what can be read between two  $b^{\pm 1}$ . Thus look at a collection of successive segments such that the first segment starts on the left vertical side of the square, the last segment ends on the right vertical side of the square, and

no other segment starts or ends on a vertical side. A picture is drawn on figure 8.11 on page 98. Because  $\gamma$  is in particular a simple closed curve of slope  $\frac{p}{q}$  in the torus, we know that between two  $b$ , we need to read  $n$  or  $n + 1$  times the letter  $a$ , with  $n = \lfloor \frac{p}{q} \rfloor$ . Moreover, in  $\gamma$ , one letter out of two is  $c^{\pm 1}$ , thus what we read between two  $b^{\pm}$  is  $(\tilde{c}\tilde{a})^n \tilde{c}$  or  $(\tilde{c}\tilde{a})^{n+1} \tilde{c}$ , where the notation  $\tilde{a}$  means  $a$  or  $a^{-1}$  (and similarly for  $\tilde{b}$  and  $\tilde{c}$ ). By following the successive segments in the square we notice that the first segments end in the first half (the left one) of the high horizontal side of the square, so give an  $a$  in the intersection, and the last ones in the second half (the right one), hence give a  $a^{-1}$ . So we can be a bit more precise and write  $(\tilde{c}\tilde{a})^{n_1} \tilde{c} (a^{-1} \tilde{c})^{n_2} \tilde{b}$ , with  $n_1 + n_2 \in \{n, n + 1\}$ . But before the letter  $a$  stands necessarily the letter  $c$  (since the slope is non-negative) and after the letter  $a^{-1}$  stands necessarily the letter  $c^{-1}$  (for the same reason), therefore a subword of  $\gamma$  read between two letters  $b^{\pm}$  is of the form  $(ca)^{n_1} \tilde{c} (ca)^{-n_2} \tilde{b}$ . Finally, the intersection points between the curve and the horizontal side of the square are evenly spaced then we must also have  $|n_1 - n_2| \leq 1$ . Thus :

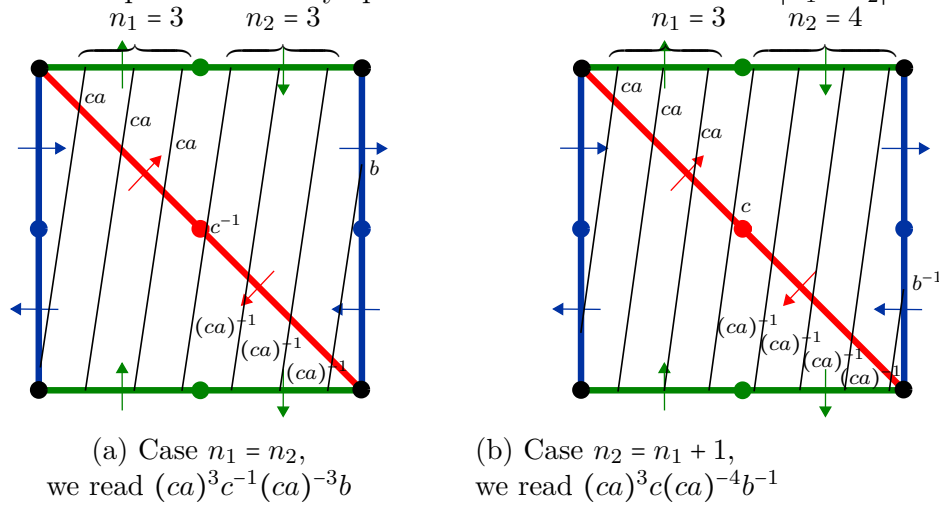

Figure 8.11: A line in the square between two intersections with the vertical side

- If  $n$  is even :
  - If  $n_1 + n_2 = n$ , then necessarily  $n_1 = n_2 = \frac{n}{2}$ , so we recover the subword  $w(\tilde{c}, \tilde{b})$  defined in the lemma.
  - If  $n_1 + n_2 = n + 1$ , then necessarily  $\{n_1, n_2\} = \{\frac{n}{2}, \frac{n}{2} + 1\}$ , so we recover the subwords  $w'(\tilde{c}, \tilde{b}, 0)$  and  $w'(\tilde{c}, \tilde{b}, 1)$  defined in the lemma.
- If  $n$  is odd :
  - If  $n_1 + n_2 = n$ , then necessarily  $\{n_1, n_2\} = \{\frac{n-1}{2}, \frac{n+1}{2}\}$ , so we recover the subwords  $w(\tilde{c}, \tilde{b}, 0)$  and  $w(\tilde{c}, \tilde{b}, 1)$  defined in the lemma.
  - If  $n_1 + n_2 = n + 1$ , then necessarily  $n_1 = n_2 = \frac{n+1}{2}$ , so we recover the subword  $w'(\tilde{c}, \tilde{b})$  defined in the lemma.

□

Let us now specify the previous result in the case where the slope is an integer.

**Lemma 8.6.** *Let  $\gamma \in \mathcal{S}(S_{0,4})$ . Suppose that  $\text{Slope}(\gamma) = [n]$ , with  $n \in \mathbb{N}$ . Then (up to conjugation and inversion) :*

$$\gamma = \begin{cases} (ca)^{\frac{n}{2}}c(ca)^{-\frac{n}{2}}b & \text{if } n \text{ is even} \\ (ca)^{\frac{n+1}{2}}c^{-1}(ca)^{-\frac{n-1}{2}}b & \text{if } n \text{ is odd} \end{cases}$$

*Proof.* Since the slope of  $\gamma$  is an integer  $n \in \mathbb{N}$ , the letter  $b$  (or  $b^{-1}$ ) appears exactly once in the word  $\gamma$ . Thus, by Lemma 8.5, the word  $\gamma$  (up to cyclic permutation) is one of the 24 words given in the statement of the lemma. Moreover, since the slope is  $n$ , the letter  $a^{\pm 1}$  appears exactly  $n$  times. Then  $\gamma$  must be one of the following words :  $w(\tilde{c}, \tilde{b}), w(\tilde{c}, \tilde{b}, 0), w(\tilde{c}, \tilde{b}, 1)$ .

- Suppose that  $n$  is even, then  $\gamma$  is (up to permutation and inversion) of the form :  $w(\tilde{c}, \tilde{b}) = (ca)^{\frac{n}{2}}\tilde{c}(ca)^{-\frac{n}{2}}\tilde{b}$ . Up to taking the inverse, we can assume that the power on  $b$  is  $+1$ . It remains to determine the power of the letter  $c$  in the middle of the word. Recall that we can see the curve  $\gamma$  as a straight line of slope  $n$  in the square  $[0, 2]$ , that is, successive parallel segments evenly spaced of slope  $n$ . It is easy to check on a drawing that if the power on  $b$  is  $+1$  (which means that the first segment starts on the upper-half of the left vertical side of the square and that the last segment ends on the upper-half of the right vertical side of the square), then the  $(\frac{n}{2} + 1)$ -th segment in the square must cross the diagonal in its first half. This means that the power on the letter  $c$  in the middle is  $+1$ , hence  $\gamma = (ca)^{\frac{n}{2}}c(ca)^{-\frac{n}{2}}b$  (up to permutation and inversion).

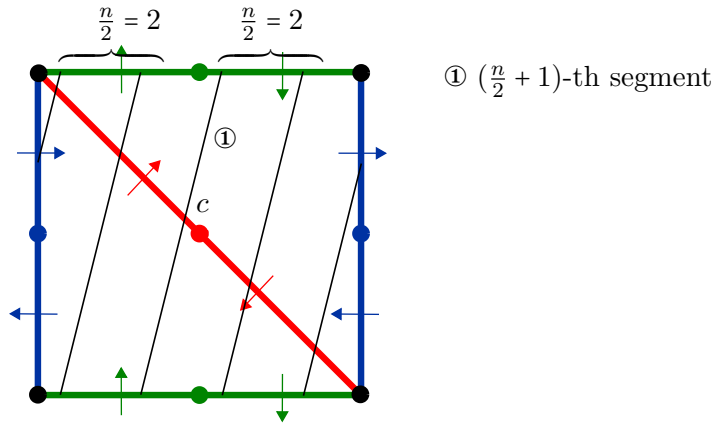

Figure 8.12: A line of slope  $n = 4$  in the square

- Suppose that  $n$  is odd, then  $\gamma$  is (up to permutation and inversion) of the form  $w(\tilde{c}, \tilde{b}, 0)$  or  $w(\tilde{c}, \tilde{b}, 1)$ . Up to taking the inverse, we can assume that the power on  $b$  is  $+1$ . It remains to check that the power on  $(ca)$  is  $\frac{n+1}{2}$  and that the power on the letter  $c$  in the middle is  $-1$ . Notice that the equation of the line containing the  $(\frac{n+1}{2})$ -th segment corresponding to the curve  $\gamma$  in the square is given by :  $y = h + n(x - \frac{2}{n}\frac{n-1}{2}) = h + nx - n + 1$ , where  $h$  is the real such that the first segment starts at the point  $(0, h)$  (thus  $1 < h < 2$ ). When  $y = 2$ , we find  $x = \frac{n+1-h}{n}$ , but  $h > 1$ , so  $x < 1$ , and this proves that  $\gamma$  is of the form  $(ca)^{\frac{n+1}{2}}\tilde{c}(ca)^{-\frac{n-1}{2}}b$ . Let us determine the power on  $c$ . The equation of the line containing the  $(\frac{n+1}{2} + 1)$ -th segment

of the curve  $\gamma$  is  $y = h + n(x - \frac{2}{n} \frac{n+1}{2}) = h + nx - n - 1$ . When  $x = 1$ , we find  $y = h - 1 < 1$ , and this proves that the power on  $c$  is  $-1$ . Hence  $\gamma = (ca)^{\frac{n+1}{2}} c^{-1} (ca)^{-\frac{n-1}{2}} b$  (up to permutation and inversion).

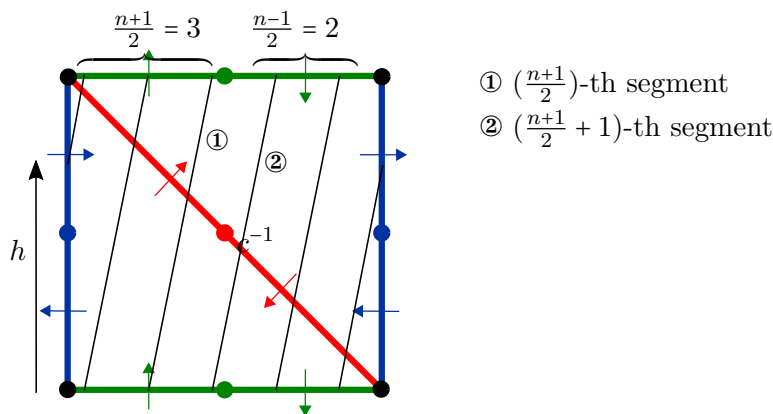

Figure 8.13: A line of slope  $n = 5$  in the square

□

**Corollary 8.7.** *Let  $\gamma \in \pi_1(S_{0,4})$  be a cyclically reduced element representing a simple closed curve on  $S_{0,4}$ . There exists two words  $\delta_1, \delta_2 \in \pi_1(S_{0,4})$  such that for all  $n \in \mathbb{N}$ , the element  $\gamma^n \delta_1 \gamma^{-n} \delta_2$  belongs to  $\mathcal{S}(S_{0,4})$ .*

*Proof.* First notice that if the Lemma is true for some  $\gamma$ , it is still true for the inverse of  $\gamma$  and for a conjugate of  $\gamma$ . Hence, since any two elements of  $\mathbb{F}_3$  (induced by simple closed curves) with the same slope are equal up to conjugacy and inversion, it is sufficient to show the lemma for any element with the same slope as  $\gamma$ .

Let  $\frac{p}{q} = \text{Slope}(\gamma)$ . There exists another rational  $\frac{p'}{q'}$  such that  $|pq' - p'q| = \pm 1$ . Now use Lemma 8.4 to show the existence of a mapping class  $\varphi \in \text{MCG}(S_{0,4})$  such that  $\text{Slope}(\varphi(ca)) = \frac{p}{q}$  and  $\text{Slope}(\varphi(cb)) = \frac{p'}{q'}$ . Choose a representative of  $\varphi$  in  $\text{Homeo}(S_{0,4})$  and with a slight abuse of notation still denote it by  $\varphi$ . Let  $\eta = \varphi(ca)$ . Then  $\eta \in \mathcal{S}(S_{0,4})$  and  $\text{Slope}(\eta) = \text{Slope}(\gamma)$ . Moreover, by Lemma 8.6, we deduce that for all  $n \in \mathbb{N}$ ,  $(ca)^n c (ca)^{-n} b \in \mathcal{S}(S_{0,4})$ . Then, since  $\varphi \in \text{Homeo}(S_{0,4})$ , we also obtain that  $\varphi((ca)^n c (ca)^{-n} b) \in \mathcal{S}(S_{0,4})$  for all  $n \in \mathbb{N}$ . But we have  $\varphi((ca)^n c (ca)^{-n} b) = \eta^n \varphi(c) \eta^{-n} \varphi(b)$  hence the corollary with  $\delta_1 = \varphi(c)$  and  $\delta_2 = \varphi(b)$ . □

We now end this section by writing any element  $\gamma$  in  $\mathcal{S}(S_{0,4})$  as a concatenation of "building blocks", each of them using some "approximation"  $\gamma_i$  of  $\gamma$ . We can approximate  $\gamma$  at different levels, indexed by the integer  $i$ , corresponding to the successive steps in the continued fraction expansion of the slope of  $\gamma$ .

**Lemma 8.8.** *Let  $i \geq 1$  and let  $[n_1, \dots, n_i]$  be the continued fraction expansion of a rational number. Then there exists a simple word  $\gamma_i \in \mathcal{S}(S_{0,4})$  of slope  $[n_1, \dots, n_i]$ , and two words  $\delta_1, \delta_2 \in \pi_1(S_{0,4})$ , such that every simple word  $\gamma \in \mathcal{S}(S_{0,4})$  with continued fraction expansion  $[n_1, \dots, n_r]$ , with  $r > i$ , can be written as a (cyclic-permutation of a) concatenation of subwords of the form :*

$$(\gamma_i)^{m_1} \tilde{\delta}_1 (\gamma_i)^{-m_2} \tilde{\delta}_2$$

with  $m_1, m_2 \in \{\lfloor \frac{n_{i+1}}{2} \rfloor, \lfloor \frac{n_{i+1}}{2} \rfloor + 1\}$  and  $\tilde{\delta}_1 \in \{\delta_1, \delta_1^{-1}\}, \tilde{\delta}_2 \in \{\delta_2, \delta_2^{-1}\}$ .

Moreover, if  $r = i + 1$ , that is  $\text{Slope}(\gamma) = [n_1, \dots, n_i, n_r]$ , then (up to conjugation and inversion) :

$$\gamma = \begin{cases} (\gamma_i)^{\frac{n_r}{2}} \delta_1 (\gamma_i)^{-\frac{n_r}{2}} \delta_2 & \text{if } n_r \text{ is even} \\ (\gamma_i)^{\frac{n_r+1}{2}} \delta_1^{-1} (\gamma_i)^{-\frac{n_r-1}{2}} \delta_2 & \text{if } n_r \text{ is odd} \end{cases}$$

*Proof.* By permuting the three elements of the basis,  $a, b, c$ , we can assume that the slope of  $\gamma$  is non-negative.

We start by using Lemma 8.4 to obtain the existence of a mapping class  $\varphi \in \text{MCG}(S_{0,4})$  such that  $\text{Slope}(\varphi(ca)) = [n_1, \dots, n_i]$  and  $\text{Slope}(\varphi_i(cb)) = [n_1, \dots, n_i + 1]$ . Choose a representative of  $\varphi \in \text{MCG}(S_{0,4}) \subset \text{Out}(\mathbb{F}_3)$  and with a slight abuse of notation still denote it by  $\varphi \in \text{Aut}(\mathbb{F}_3)$ . Denote  $a' = \varphi_i(a), b' = \varphi_i(b), c' = \varphi_i(c)$  and  $\gamma_i = \varphi(ca)$ . Then  $a', b', c'$  is a basis of  $\mathbb{F}_3$  since  $\varphi$  is an automorphism of  $\mathbb{F}_3$  and in this new basis the slope of  $\gamma$  is  $[n_{i+1}, \dots, n_r]$  (see Remark 8.3). Hence, by the Lemma 8.5 applied to the new basis  $\mathbb{F}_3 = \langle a', b', c' \rangle$ , the word  $\gamma$  can be written as a concatenation of subwords of the form  $(c'a')^{m_1} \tilde{c}' (c'a')^{-m_2} \tilde{b}'$ , with  $m_1, m_2 \in \{\frac{n_{i+1}}{2}, \frac{n_{i+1}}{2} + 1\}$  if  $n_{i+1}$  is even,  $m_1, m_2 \in \{\frac{n_{i+1}-1}{2}, \frac{n_{i+1}+1}{2}\}$  if  $n_{i+1}$  is odd. But we have :

$$(c'a')^{m_1} \tilde{c}' (c'a')^{-m_2} \tilde{b}' = (\varphi_i(ca))^{m_1} \widetilde{\varphi_i(c)} (\varphi_i(ca))^{-m_2} \widetilde{\varphi_i(b)} = (\gamma_i)^{m_1} \widetilde{\varphi_i(c)} (\gamma_i)^{-m_2} \widetilde{\varphi_i(b)}.$$

Hence we obtain the first part of the lemma with  $\delta_1 = \varphi_i(c)$  and  $\delta_2 = \varphi_i(b)$ .

For the second part, now suppose that  $r = i + 1$ , that is  $\text{Slope}(\gamma) = [n_1, \dots, n_i, n_r]$ . Then, in the new basis  $\mathbb{F}_3 = \langle a', b', c' \rangle$ , the slope of  $\gamma$  is simply  $[n_r] = n_r \in \mathbb{N}$  (again see Remark 8.3). Thus we can use Lemma 8.6 to ensure that (up to permutation and inversion) :

$$\begin{aligned} \gamma &= \begin{cases} (c'a')^{\frac{n_r}{2}} c' (c'a')^{-\frac{n_r}{2}} b' = (\varphi(ca))^{\frac{n_r}{2}} \varphi(c) (\varphi(ca))^{-\frac{n_r}{2}} \varphi(b) & \text{if } n_r \text{ is even} \\ (c'a')^{\frac{n_r+1}{2}} c'^{-1} (c'a')^{-\frac{n_r-1}{2}} b' = (\varphi(ca))^{\frac{n_r+1}{2}} \varphi(c)^{-1} (\varphi(ca))^{-\frac{n_r-1}{2}} \varphi(b) & \text{if } n_r \text{ is odd} \end{cases} \\ &= \begin{cases} (\gamma_i)^{\frac{n_r}{2}} \delta_1 (\gamma_i)^{-\frac{n_r}{2}} \delta_2 & \text{if } n_r \text{ is even.} \\ (\gamma_i)^{\frac{n_r+1}{2}} \delta_1^{-1} (\gamma_i)^{-\frac{n_r-1}{2}} \delta_2 & \text{if } n_r \text{ is odd.} \end{cases} \end{aligned}$$

□

## 8.4 Some generalities about lattices in $\mathbb{R}^2$

In section 8.6, we will prove the main proposition of this chapter (Proposition 8.16), which studies the redundancy of subwords of some specific lengths in a simple word. We will adopt a geometric approach using lattices in  $\mathbb{R}^2$ . Thus, in this section, we need to set up some notations and to state a few facts about the geometry of lattices in  $\mathbb{R}^2$  that will be useful for us in the following.

### 8.4.1 Rectangles adapted to a basis of a lattice and tiling of $\mathbb{R}^2$

Let us fix  $\Lambda$  a lattice in  $\mathbb{R}^2$ . We consider  $\mathbb{R}^2$  both endowed with its usual euclidean structure and frame and with the lattice  $\Lambda$ . Let  $(u, v)$  be a basis of  $\Lambda$  and  $x \in \Lambda$ .

In coordinates, write  $x = (x_1, x_2)$ ,  $u = (u_1, u_2)$  and  $v = (v_1, v_2)$ . Let us assume that the basis  $(u, v)$  satisfies  $u_1 > 0, v_1 > 0$  and  $u_2 < 0 < v_2$ . In particular this requires that  $\text{Slope}(u) = \frac{u_2}{u_1} < 0 < \frac{v_2}{v_1} = \text{Slope}(v)$ . Let us now define :

$$S(x, u, v) = [x_1, x_1 + u_1 + v_1] \times [x_2 + u_2, x_2 + v_2]. \quad (8.1)$$

Thus,  $S(x, u, v)$  is the only rectangle with horizontal and vertical sides containing on each of its sides exactly one point of the set  $\{x, x + u, x + v, x + u + v\}$ . Note the important fact that since  $(u, v)$  is a basis of  $\Lambda$ , there is no other point of  $\Lambda$  in  $S(x, u, v)$ . In particular, there is no point of  $\Lambda$  in the interior of  $S(x, u, v)$ .

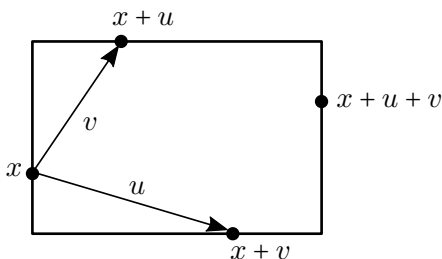

Figure 8.14: The rectangle  $S(x, u, v)$ .

We will also need to consider the same square without its right vertical side. Then we choose the following notation :

$$S_*(x, u, v) = [x_1, x_1 + u_1 + v_1[ \times [x_2 + u_2, x_2 + v_2]. \quad (8.2)$$

In the same way that we had previously defined the type of a point of  $\mathbb{Z}^2$  as its equivalence class modulo  $2\mathbb{Z}^2$ , we can now define the *type* of a point in  $\Lambda$  as its equivalence class modulo  $2\Lambda$ . Hence there are 4 types of points. Note that the four points  $x, x + u, x + v$  and  $x + u + v$  of the lattice  $\Lambda$  are all of different types. If  $t$  is a type, we define the  $(u, v)$ -*opposite type* of  $t$  as the type of the point  $x + u + v$ , where  $x$  is any point of type  $t$  (this definition does not depend on the choice of the point  $x$  of type  $t$ ). We denote by  $\Lambda(t)$  the set of points in  $\Lambda$  of type  $t$ .

We now want to cover the plane  $\mathbb{R}^2$  with the rectangles  $S(x, u, v)$ , for  $x \in \Lambda(t) \cup \Lambda(\bar{t})$ . The situation will not be the same according to the signs of  $\text{Slope}(u + v)$  and  $\text{Slope}(v - u)$ . When  $\text{Slope}(u + v)$  and  $\text{Slope}(v - u)$  are of the same sign, the rectangles  $S(x, u, v)$ , for  $x \in \Lambda(t) \cup \Lambda(\bar{t})$  cover the whole  $\mathbb{R}^2$ . However, there is some overlap. This is the purpose of the following lemma :

**Lemma 8.9.** *Assume that  $\text{Slope}(u + v) \neq 0, \text{Slope}(v - u) \neq +\infty$  and  $\text{Slope}(u + v)$  and  $\text{Slope}(v - u)$  are of the same sign.*

*Let  $t$  be a type and  $\bar{t}$  its  $(u, v)$ -opposite type. Then :*

$$\mathbb{R}^2 = \bigcup_{x \in \Lambda(t) \cup \Lambda(\bar{t})} S(x, u, v)$$

Moreover,

- if  $x, x' \in \Lambda$  are of  $(u, v)$ -opposite type, then  $S(x, u, v) \cap S(x', u, v) \neq \emptyset$  if and only if  $x' = x \pm (v - u)$  or  $x' = x \pm (u + v)$  and in this case  $S(x, u, v)$  and  $S(x', u, v)$  only intersect along one of their sides. Thus, for all  $x \in \Lambda(t), x' \in \Lambda(\bar{t}), S_*(x, u, v) \cap S_*(x', u, v) = \emptyset$ .
- if  $x, x' \in \Lambda$  are of the same type, then we distinguish according to the sign of  $\text{Slope}(u + v)$  and  $\text{Slope}(v - u)$  :

- If  $\text{Slope}(u + v) > 0$  and  $\text{Slope}(v - u) > 0$ , then there exists  $N \in \mathbb{N}$  such that :  
 $S(x, u, v) \cap S(x', u, v) \neq \emptyset$  if and only if  $x' = x \pm 2ku$ , with  $|k| \leq N$ . In this case :

$$S(x, u, v) \cap \left( \bigcup_{1 \leq k \leq N} S(x + 2ku, u, v) \right) = [x_1 + 2u_1, x_1 + u_1 + v_1] \times [x_2 + u_2, x_2 + 2u_2 + v_2]$$

$$S(x, u, v) \cap \left( \bigcup_{1 \leq k \leq N} S(x - 2ku, u, v) \right) = [x_1, x_1 - u_1 + v_1] \times [x_2 - u_2, x_2 + v_2]$$

- If  $\text{Slope}(u + v) < 0$  and  $\text{Slope}(v - u) < 0$ , then there exists  $N \in \mathbb{N}$  such that :  
 $S(x, u, v) \cap S(x', u, v) \neq \emptyset$  if and only if  $x' = x \pm 2kv$ , with  $|k| \leq N$ . In this case :

$$S(x, u, v) \cap \left( \bigcup_{1 \leq k \leq N} S(x + 2kv, u, v) \right) = [x_1 + 2v_1, x_1 + u_1 + v_1] \times [x_2 + u_2 + 2v_2, x_2 + v_2]$$

$$S(x, u, v) \cap \left( \bigcup_{1 \leq k \leq N} S(x - 2kv, u, v) \right) = [x_1, x_1 + u_1 - v_1] \times [x_2 + u_2, x_2 - v_2]$$

*Proof.* Since the fundamental quadrilateral  $(x, x+u, x+v, x+u+v)$  of  $\mathbb{R}^2/\Lambda$  is contained in  $S(x, u, v)$ , then the rectangles  $S(x, u, v)$ , for  $x \in \Lambda$ , tile  $\mathbb{R}^2$  (we mean that  $\mathbb{R}^2 = \bigcup_{x \in \Lambda} S(x, u, v)$ ). So we need to show that, if  $x \in \Lambda \setminus \Lambda(t) \cup \Lambda(\bar{t})$ , we can cover  $S(x, u, v)$  by a union of rectangles  $S(y, u, v)$ , with  $y \in \Lambda(t) \cup \Lambda(\bar{t})$ . It is easy to check that, when  $\text{Slope}(u + v)$  and  $\text{Slope}(v - u)$  are of the same sign, we have :

$$S(x, u, v) \subset S(x - u, u, v) \cup S(x + u, u, v) \cup S(x + v, u, v) \cup S(x - v, u, v)$$

as represented in figure 8.15 on page 104. But notice that when  $x \in \Lambda \setminus \Lambda(t) \cup \Lambda(\bar{t})$ , the points  $x + u, x - u, x + v$  and  $x - v$  all four belong to  $\Lambda(t) \cup \Lambda(\bar{t})$ , hence the claim.

Now, we investigate the intersection between rectangles. Let  $x \in \Lambda$ . Let us determine which rectangles intersects  $S(x, u, v)$ . For  $S(y, u, v)$  to intersect  $S(x, u, v)$ , the point  $y$  must be contained in  $\mathcal{Z} = [x_1 - u_1 - v_1, x_1 + u_1 + v_1] \times [x_2 + u_2 - v_2, x_2 + v_2 - u_2]$ . Let  $t$  be the type of  $x$ . See figure 8.16 on page 104.

- The only points of the lattice  $\Lambda$  of type  $\bar{t}$  which are contained in  $\mathcal{Z}$  are  $x+u+v, x-u-v, x+v-u$  and  $x-v+u$ . Moreover, the rectangle  $S(x, u, v)$  intersect  $S(x+u+v, u, v)$  only along one of their side, and ditto for  $S(x-u-v, u, v), S(x+v-u, u, v)$  and  $S(x-v+u, u, v)$ . Therefore  $S_*(x, u, v) \cap S_*(x+u+v, u, v) = S_*(x, u, v) \cap S_*(x-u-v, u, v) = \emptyset$ .
- The only points of the lattice  $\Lambda$  of type  $t$  which can be contained in  $\mathcal{Z}$  are of the form  $x+2ku$  and  $x+2kv$ , for  $k \in \mathbb{Z}$ .



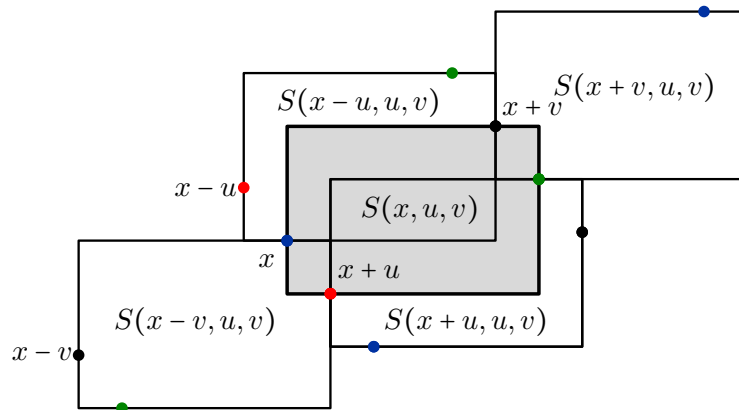

Figure 8.15: The rectangle  $S(x, u, v)$  is covered by rectangles of type  $t$  and  $\bar{t}$ .

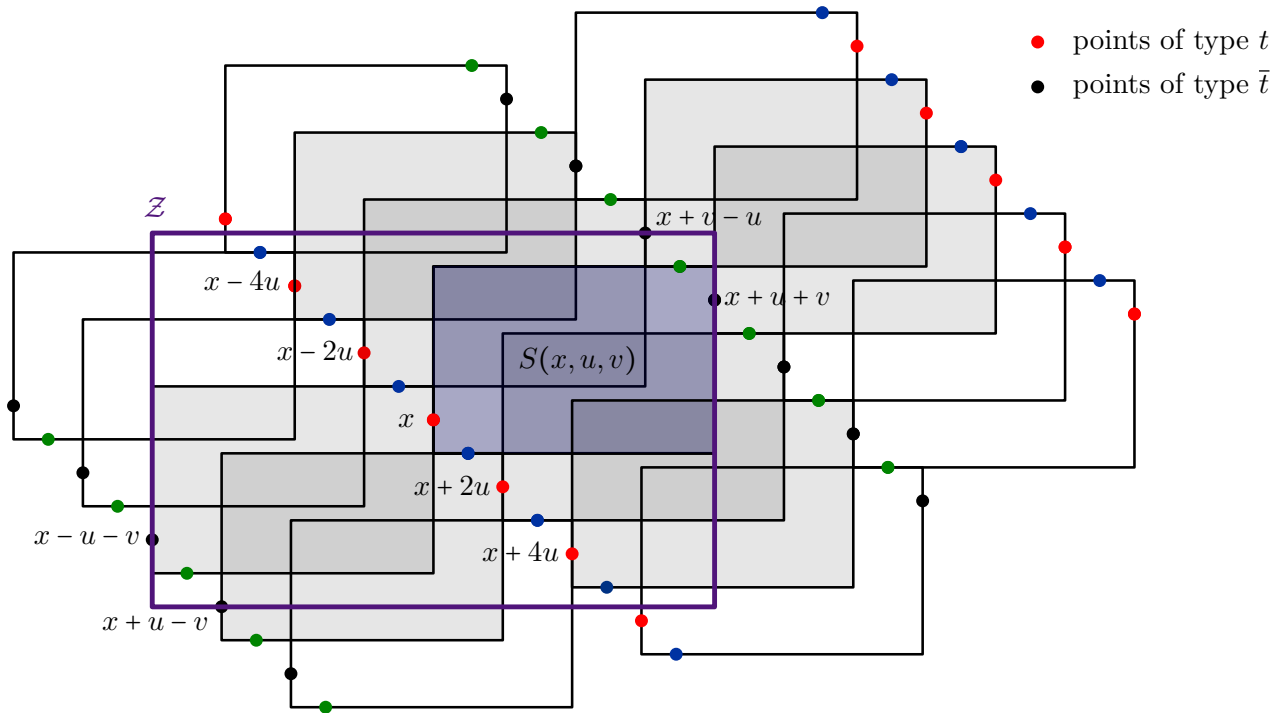

Figure 8.16: Rectangles of type  $t$  and  $\bar{t}$  (in grey) which intersect  $S(x, u, v)$  (in the center). In this case,  $\text{Slope}(u + v) > 0$  and  $N = 2$ .

- If  $\text{Slope}(u + v) > 0$  and  $\text{Slope}(v - u) > 0$ , then  $0 < u_1 < v_1$  and  $0 < -u_2 < v_2$ . So we deduce that  $x + 2kv \in \mathcal{Z}$  if and only if  $k = 0$ . Therefore we deduce the existence of an integer  $N \in \mathbb{N}$  such that the only points of the lattice  $\Lambda$  of type  $t$  which are contained in  $\mathcal{Z}$  are of the form  $x + 2ku$ , with  $|k| \leq N$ . We also deduce that for  $1 \leq k \leq N$ ,  $S(x, u, v) \cap S(x + 2ku, u, v) \subset S(x, u, v) \cap S(x + 2u, u, v)$  and  $S(x, u, v) \cap S(x - 2ku, u, v) \subset S(x, u, v) \cap S(x - 2u, u, v)$ , hence the formula for the intersection.
- If  $\text{Slope}(u + v) < 0$  and  $\text{Slope}(v - u) < 0$ , then  $0 < v_1 < u_1$  and  $0 < v_2 < -u_2$ . So we do

the same reasoning as in the previous case exchanging  $u$  and  $v$  to obtain the analogous result.

□

Let us denote :

$$S^+(x, u, v) = \begin{cases} S(x, u, v) \cap S(x + 2u, u, v) & \text{if Slope}(u + v) \geq 0 \text{ and Slope}(v - u) \geq 0 \\ S(x, u, v) \cap S(x + 2v, u, v) & \text{if Slope}(u + v) \leq 0 \text{ and Slope}(v - u) \leq 0 \end{cases}$$

$$S^-(x, u, v) = \begin{cases} S(x, u, v) \cap S(x - 2u, u, v) & \text{if Slope}(u + v) \geq 0 \text{ and Slope}(v - u) \geq 0 \\ S(x, u, v) \cap S(x - 2v, u, v) & \text{if Slope}(u + v) \leq 0 \text{ and Slope}(v - u) \leq 0 \end{cases}$$

and  $S^\pm(x, u, v) = S^+(x, u, v) \cup S^-(x, u, v)$ .

Hence  $S^\pm(x, u, v)$  is the subset of the tile  $S(x, u, v)$  in which the overlap occurs.

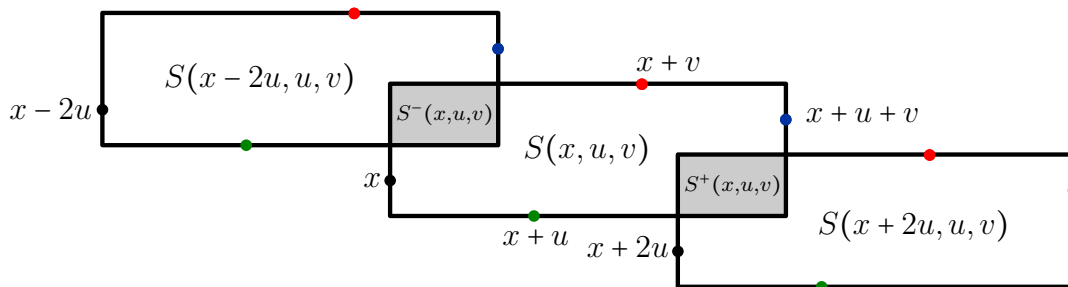

Figure 8.17: The rectangles  $S(x, u, v), S(x - 2u, u, v), S(x + 2u, u, v)$  and their intersections  $S^-(x, u, v)$  and  $S^+(x, u, v)$ .

Let us now deal with the case where  $\text{Slope}(u + v)$  and  $\text{Slope}(v - u)$  are of opposite signs. In this case, the rectangles  $S(x, u, v)$  for  $x \in \Lambda$  of type  $t$  or  $\bar{t}$  do not cover the whole plane  $\mathbb{R}^2$ . We have to add some "rest", which we define below and denote by  $R(x, u, v)$  (see figure 8.18 on page 106).

$$R(x, u, v) = \begin{cases} [x_1, x_1 + u_1 - v_1] \times [x_2 - v_2, x_2 + u_2] & \text{if Slope}(u + v) \geq 0 \text{ and Slope}(v - u) \leq 0 \\ [x_1, x_1 - u_1 + v_1] \times [x_2 + v_2, x_2 - u_2] & \text{if Slope}(u + v) \leq 0 \text{ and Slope}(v - u) \geq 0 \end{cases} \quad (8.3)$$

$$R_*(x, u, v) = \begin{cases} [x_1, x_1 + u_1 - v_1] \times [x_2 - v_2, x_2 + u_2] & \text{if Slope}(u + v) \geq 0 \text{ and Slope}(v - u) \leq 0 \\ [x_1, x_1 - u_1 + v_1] \times [x_2 + v_2, x_2 - u_2] & \text{if Slope}(u + v) \leq 0 \text{ and Slope}(v - u) \geq 0 \end{cases} \quad (8.4)$$

In this context, there will be no overlap. Now we can state the corresponding lemma :

**Lemma 8.10.** *Assume that  $\text{Slope}(u+v) \neq 0$ ,  $\text{Slope}(v-u) \neq \infty$  and that  $\text{Slope}(u+v)$  and  $\text{Slope}(v-u)$  are of opposite signs.*

*Let  $t$  be a type and  $\bar{t}$  its  $(u, v)$ -opposite type. Then :*

$$\mathbb{R}^2 = \bigcup_{x \in \Lambda(t) \cup \Lambda(\bar{t})} (S(x, u, v) \cup R(x, u, v)).$$

*Moreover, any two rectangles of this tiling can only intersect along one of their sides.*

*Proof.* As in the proof of Lemma 8.9, first remark that the rectangles  $S(x, u, v)$ , for  $x \in \Lambda$ , tile  $\mathbb{R}^2$  (we mean that  $\mathbb{R}^2 = \bigcup_{x \in \Lambda} S(x, u, v)$ ). So we need to cover  $S(x, u, v)$ , when  $x \notin \Lambda(t) \cup \Lambda(\bar{t})$ , by a union of rectangles  $S(y, u, v)$  and  $R(y, u, v)$ , with  $y \in \Lambda(t) \cup \Lambda(\bar{t})$ . It is easy to check that, when  $\text{Slope}(u+v)$  and  $\text{Slope}(v-u)$  are of opposite signs, we have :

$$S(x, u, v) \subset S(x+u, u, v) \cup S(x-u, u, v) \cup S(x+v, u, v) \cup S(x-v, u, v) \cup R(x+v, u, v)$$

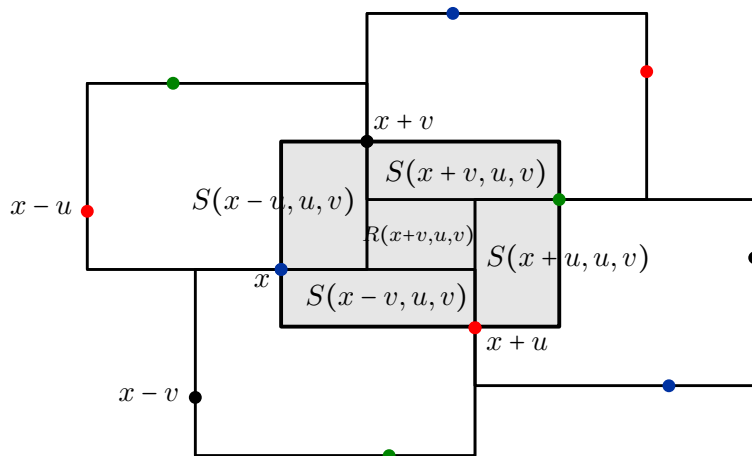

Figure 8.18: The rectangle  $S(x, u, v)$  is covered by rectangles  $S(y, u, v)$  and  $R(y, u, v)$  of type  $t$  and  $\bar{t}$

We conclude by noting, as for the proof of Lemma 8.9, that when  $x \in \Lambda \setminus (\Lambda(t) \cup \Lambda(\bar{t}))$ , the points  $x+u, x-u, x+v$  and  $x-v$  all four belong to  $\Lambda(t) \cup \Lambda(\bar{t})$ , hence the claim.

Now we investigate the intersection between rectangles. Let  $x \in \Lambda$ . As in the proof of Lemma 8.9, for  $S(y, u, v)$  to intersect  $S(x, u, v)$ , we have that the point  $y$  must belong to the rectangle  $\mathcal{Z} = [x_1 - u_1 - v_1, x_1 + u_1 + v_1] \times [x_2 + u_2 - v_2, x_2 + v_2 - u_2]$ . Let  $t$  be the type of  $x$ .

- Again as in the proof of Lemma 8.9, we note that the only points of the lattice  $\Lambda$  of type  $\bar{t}$  in  $\mathcal{Z}$  are  $x+u+v, x-u-v, x+v-u$  and  $x-v+u$ , and the rectangle  $S(x, u, v)$  intersects  $S(x+u+v, u, v)$  only along one of its sides, and ditto for  $S(x-u-v, u, v)$ ,  $S(x+v-u, u, v)$  and  $S(x-v+u, u, v)$ .

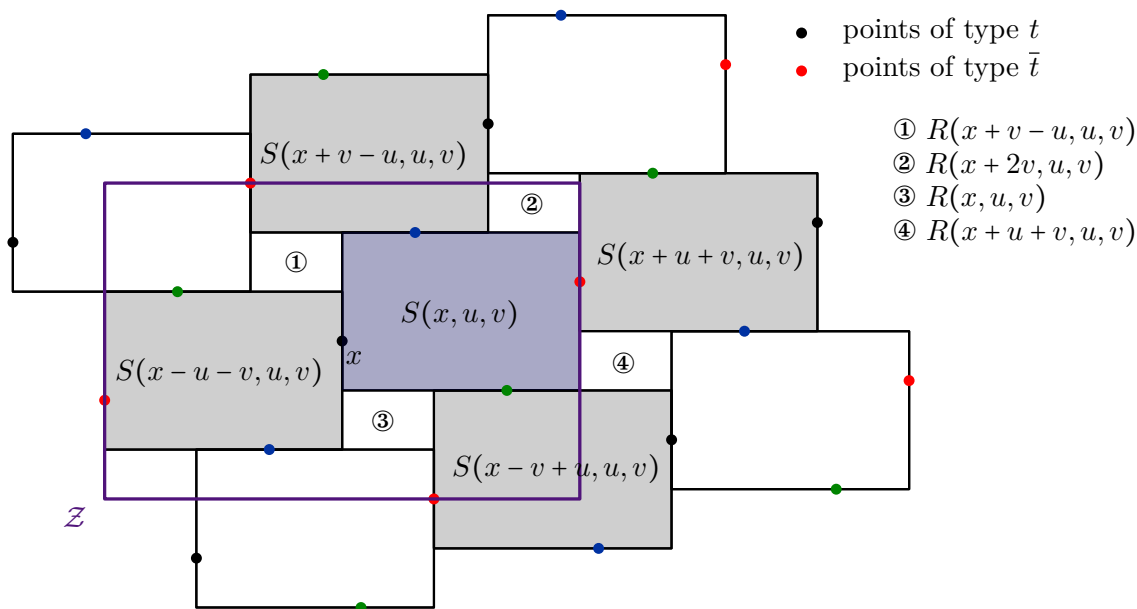

Figure 8.19: The tiling of  $\mathbb{R}^2$  by tiles  $S(y, u, v)$  and  $R(y, u, v)$ , with  $y \in \Lambda(t) \cup \Lambda(\bar{t})$ .

- Again as in the proof of Lemma 8.9, we note that the only points of the lattice  $\Lambda$  of type  $t$  in  $\mathcal{Z}$  are of the form  $x + 2ku$  and  $x + 2kv$ . But using our hypothesis on the slopes of  $u + v$  and  $v - u$ , we obtain that either  $0 < u_1 < v_1$  and  $0 < v_2 < -u_2$  or  $0 < v_1 < u_1$  and  $0 < -u_2 < v_2$ . From these inequalities we deduce that  $x + 2ku$  belongs to  $\mathcal{Z}$  if and only if  $k = 0$  and  $x + 2kv$  belongs to  $\mathcal{Z}$  if and only if  $k = 0$ . Therefore  $S(x, u, v)$  intersects no other rectangle  $S(y, u, v)$  of type  $t$ .

At last, note that by construction,  $R(x, u, v)$  intersects only  $S(x, u, v)$ ,  $S(x - u - v, u, v)$ ,  $S(x - 2v, u, v)$  and  $S(x + u - v, u, v)$ , and the intersection occurs only along one of their sides.  $\square$

Notice that since  $(u, v)$  is a basis of  $\Lambda$ , so are  $(u, u + v)$  and  $(u + v, v)$ . The next lemma, in the case where  $\text{Slope}(u + v)$  and  $\text{Slope}(v - u)$  are of opposite signs, aims at showing that an horizontal segment of length  $l = \max(u_1, v_1)$  is necessarily included in some  $S(x, u, v)$ ,  $S(x, u, u + v)$  or

$$S(x, u + v, v). \text{ Denote } (u'v') = \begin{cases} (u, u + v) & \text{if } \text{Slope}(u + v) \geq 0 \\ (u + v, v) & \text{if } \text{Slope}(u + v) \leq 0 \end{cases},$$

$$S'(x, u, v) = S(x, u', v') \quad S'_*(x, u, v) = S_*(x, u', v') \quad \text{and} \quad S'^{\pm}(x, u, v) = S^{\pm}(x, u', v').$$

See figure 8.20 on page 108 for  $S'(x, u, v)$ , in the case  $\text{Slope}(u + v) \geq 0$  and  $\text{Slope}(v - u) \leq 0$ .

Now in this case ( $\text{Slope}(u + v)$  and  $\text{Slope}(v - u)$  of opposite signs), denote :

$$T(x, u, v) = \begin{cases} [x_1 + v_1, x_1 + 2u_1] \times [x_2 + u_2, x_2 + u_2 + v_2] & \text{if } \text{Slope}(u + v) \geq 0 \text{ and } \text{Slope}(v - u) \leq 0 \\ [x_1 + u_1, x_1 + 2v_1] \times [x_2 + u_2 + v_2, x_2 + v_2] & \text{if } \text{Slope}(u + v) \leq 0 \text{ and } \text{Slope}(v - u) \geq 0 \end{cases} \quad (8.5)$$

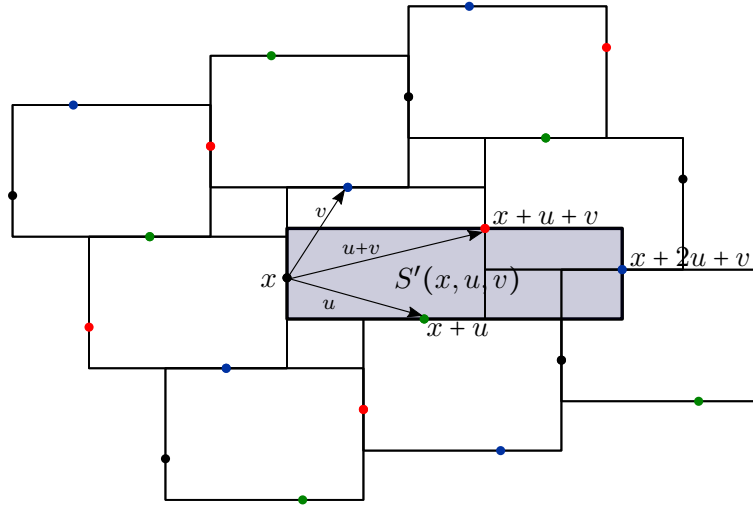

Figure 8.20: The rectangle  $S'(x, u, v)$  in the case  $\text{Slope}(u + v) \geq 0$  and  $\text{Slope}(v - u) \leq 0$ .

$$T_*(x, u, v) = \begin{cases} [x_1 + v_1, x_1 + 2u_1] \times [x_2 + u_2, x_2 + u_2 + v_2] & \text{if } \text{Slope}(u + v) \geq 0 \text{ and } \text{Slope}(v - u) \leq 0 \\ [x_1 + u_1, x_1 + 2v_1] \times [x_2 + u_2 + v_2, x_2 + v_2] & \text{if } \text{Slope}(u + v) \leq 0 \text{ and } \text{Slope}(v - u) \geq 0 \end{cases} \quad (8.6)$$

See figure 8.21 on page 108. Remark that we have :

$$T(x, u, v) \subset S'(x, u, v) \quad (8.7)$$

$$T_*(x, u, v) \subset S'_*(x, u, v) \quad (8.8)$$

$$S'^{\pm}(x, u, v) \subset S'(x, u, v) \setminus T(x, u, v) \quad (8.9)$$

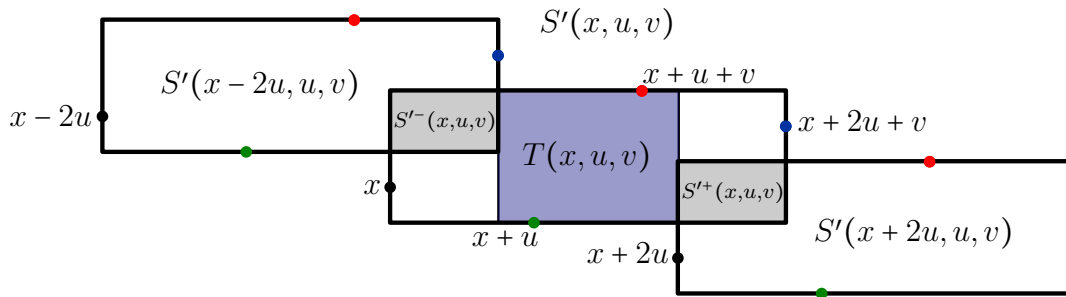

Figure 8.21: The rectangle  $T(x, u, v)$  is included in  $S'(x, u, v)$  and disjoint from  $S'^{\pm}(x, u, v)$ .

We now deduce that the rectangles  $T(x, u, v)$  are disjoint :

**Lemma 8.11.** *Assume that  $\text{Slope}(u + v)$  and  $\text{Slope}(v - u)$  are of opposite signs. Let  $t \in \Lambda/2\Lambda$  be a type and  $\bar{t}$  its  $(u, v)$ -opposite type. Let  $x, y \in \Lambda(t) \cup \Lambda(\bar{t})$ . Then the rectangles  $T(x, u, v)$  and  $T(y, u, v)$  are disjoint :  $T(x, u, v) \cap T(y, u, v) = \emptyset$ .*

*Proof.* First notice that since  $T(x, u, v) \subset S'(x, u, v)$  and  $T(y, u, v) \subset S'(y, u, v)$  (see (8.7)), intersection between  $T(x, u, v)$  and  $T(y, u, v)$  can only occur when  $S'(x, u, v)$  and  $S'(y, u, v)$  intersect

and then  $T(x, u, v) \cap T(y, u, v) \subset S'(x, u, v) \cap S'(y, u, v)$ . But  $S'(x, u, v) \cap S'(y, u, v) \subset S'^{\pm}(x, u, v)$ , so by (8.9),  $T(x, u, v) \cap T(y, u, v) \subset S'(x, u, v) \setminus T(x, u, v)$ , which implies that  $T(x, u, v) \cap T(y, u, v)$  is empty.  $\square$

The last lemma of this section shows that every horizontal segment of some prescribe length is included in a rectangle  $S(x, u, v)$  or  $T(x, u, v)$ .

**Lemma 8.12.** *Assume that  $\text{Slope}(u+v)$  and  $\text{Slope}(v-u)$  are of opposite signs. Let  $l = \max(u_1, v_1)$  (thus  $l = u_1$  if  $\text{Slope}(u+v) \geq 0$  and  $l = v_1$  if  $\text{Slope}(u+v) \leq 0$ ) and  $I$  be an horizontal segment of length  $l$  in  $\mathbb{R}^2$  which does not intersect the lattice  $\Lambda$ .*

*Then, there exists  $x \in \Lambda$  such that  $I \subset S_*(x, u, v)$  or  $I \subset T_*(x, u, v)$ .*

*Proof.* We write the proof in the case where  $\text{Slope}(u+v) \geq 0$ . Thus  $\text{Slope}(v-u) \leq 0$  and  $l = u_1$ . The other case is identical (up to a reflection across the horizontal axis).

Let  $y = (y_1, y_2)$  be the point in  $\mathbb{R}^2$  such that  $I$  is the segment which joins  $y$  to  $(y_1 + u_1, y_2)$ . Then, by Lemma 8.10, there exists a point  $x \in \Lambda$  such that  $y \in S_*(x, u, v)$  or  $y \in R_*(x, u, v)$ .

- If  $y \in S(x, u, v)$ , then we have  $x_1 \leq y_1 < x_1 + u_1 + v_1$  and  $x_2 + u_2 \leq y_2 \leq x_2 + v_2$ . We distinguish according to the zone to which  $y$  belong, represented in the figure 8.22 on page 109. The proof for each case is illustrated on figure 8.23, page 110.

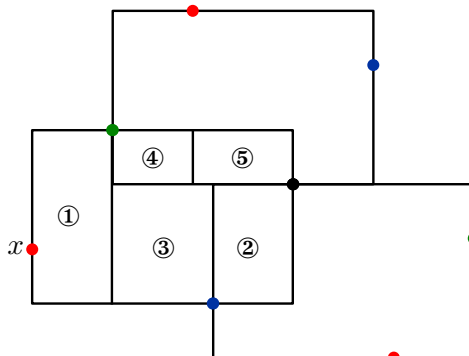

Figure 8.22: The five cases in the proof of Lemma 8.12.

1. If  $y \in \textcircled{1}$ , that is  $x_1 \leq y_1 < x_1 + v_1$ , then  $x_1 + u_1 \leq y_1 + u_1 < x_1 + u_1 + v_1$ , and so  $I \subset S_*(x, u, v)$ .
2. If  $y \in \textcircled{2}$ , that is  $x_1 + u_1 \leq y_1 < x_1 + u_1 + v_1$  and  $x_2 + u_2 \leq y_2 \leq x_2 + u_2 + v_2$ , then notice that  $y \in S_*(x + u, u, v)$  with  $x_1 + u_1 \leq y_1 < x_1 + u_1 + v_1$ , so by the previous case we have  $I \subset S_*(x + u, u, v)$ .
3. If  $y \in \textcircled{3}$ , that is  $x_1 + v_1 \leq y_1 < x_1 + u_1$  and  $x_2 + u_2 \leq y_2 \leq x_2 + u_2 + v_2$ , then we have  $x_1 + u_1 + v_1 \leq y_1 + u_1 < x_1 + 2u_1$ , and then we deduce that  $I \subset T_*(x, u, v)$ .
4. If  $y \in \textcircled{4}$  or  $y \in \textcircled{5}$ , that is  $x_1 + v_1 \leq y_1 < x_1 + u_1 + v_1$  and  $x_2 + u_2 + v_2 \leq y_2 \leq x_2 + v_2$ , then notice that  $y \in S_*(x + v, u, v)$  with  $x_2 + u_2 + v_2 \leq y_2 \leq x_2 + v_2$  and then, if  $y \in \textcircled{4}$ , that is  $y_1 < x_1 + 2v_1$ , we use the first case to deduce that  $I \subset S_*(x + v, u, v)$ , and if  $y \in \textcircled{5}$ , that is  $x_1 + 2v_1 \leq y_1 < x_1 + u_1 + v_1$ , then we use the third case to deduce that  $I \subset T_*(x + v, u, v)$  with  $I \cap S^{\pm}(x + v, u, u + v)$  is at most a point.

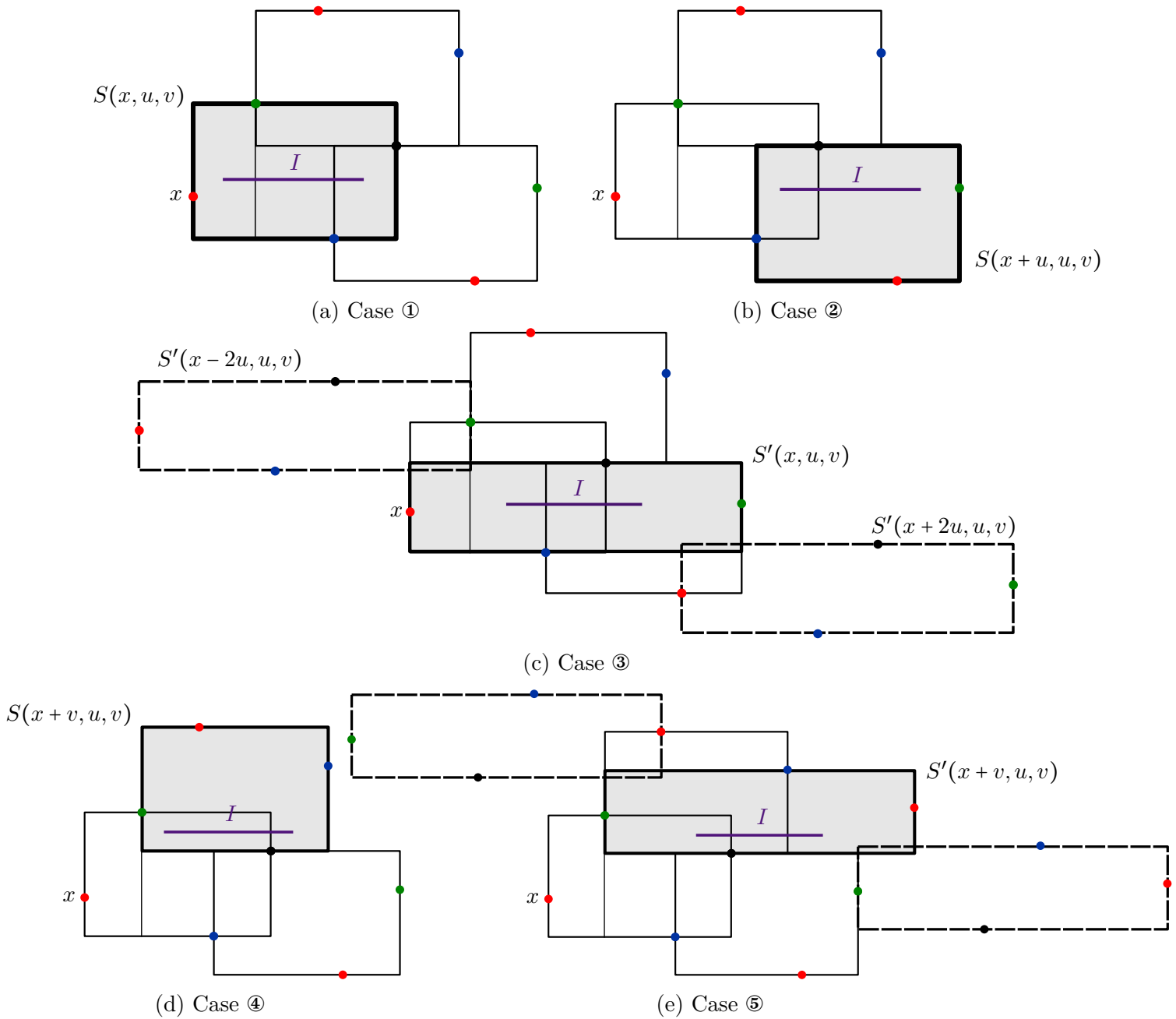

Figure 8.23: Illustration of the proof of Lemma 8.12 : The segment  $I$  is included in a rectangle.

Hence we have covered every case.

- If  $y \in R_*(x, u, v)$ , recall that  $R_*(x, u, v) \subset S_*(x - v, u, v)$ , so  $y \in S_*(x - v, u, v)$  and then we can use what we have previously done. (We can even be a bit more precise : if  $y \in R_*(x, u, v)$ , then  $y \in S_*(x - v, u, v)$  with  $x_1 \leq y_1 < x_1 + u_1 - v_1$  and  $x_2 - v_2 \leq y_2 \leq x_2 + u_2$ , so we are in the third case :  $I \subset T_*(x - v, u, v)$ ).  $\square$

### 8.4.2 Segments at height $h$ in the rectangles $S(x, u, v)$ and $R(x, u, v)$

This section is intended to apply the "tilings" obtained above to decompose an horizontal segment into sub-segments.

Let  $0 < h < 1$  and consider the horizontal segment at height  $h$  in  $S(x, u, v)$  (that is the segment from the point  $(x_1, x_2 + u_2 + h)$  to the point  $(x_1 + u_1 + v_1, x_2 + u_2 + h)$ ). Denote it by  $I_S(x, u, v, h)$  and note that  $I_S(x, u, v, h)$  is a segment of length  $u_1 + v_1$ . Similarly, let  $0 < h < u_2 + v_2$  and consider the horizontal segment at height  $h$  in  $R(x, u, v)$  (that is the segment from the point  $(x_1, x_2 - v_2 + h)$  to the point  $(x_1 + u_1 + v_1, x_2 - v_2 + h)$ ). Denote it by  $I_R(x, u, v, h)$  and note that  $I_R(x, u, v, h)$  is a segment of length  $|u_1 - v_1|$ . Finally, we also define the *type* of a segment  $I_S(x, u, v, h)$  (resp.  $I_R(x, u, v, h)$ ) as the type of the point  $x$ .

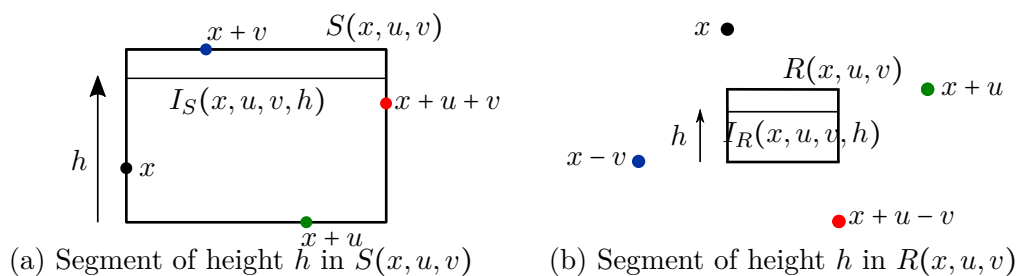

Figure 8.24: Segment at height  $h$ ,  $I_S(x, u, v, h)$  and  $I_R(x, u, v, h)$

We now decompose any horizontal segment  $I$  of any length using the tiling in the case where  $\text{Slope}(u + v)$  and  $\text{Slope}(v - u)$  are of opposite signs.

**Lemma 8.13.** *Assume that  $\text{Slope}(u + v) \neq 0$ ,  $\text{Slope}(v - u) \neq \infty$  and that  $\text{Slope}(u + v)$  and  $\text{Slope}(v - u)$  are of opposite signs.*

*Let  $t$  be a type and let  $I$  be a horizontal segment which does not intersect the lattice  $\Lambda$ .*

*There exist  $p \in \mathbb{N}$  such that for all  $0 \leq j \leq p + 1$ , there exists a point  $x_j \in \Lambda(t) \cup \Lambda(\bar{t})$  and a real  $0 < h_j < 1$  such that,*

$$I = I_0 \cup I_1 \cup \dots \cup I_p \cup I_{p+1}$$

with :

- *Either  $I_0 \subset I_S(x_0, u, v, h_0)$  or  $I_0 \subset I_R(x_0, u, v, h_0)$ , and either  $I_{p+1} \subset I_S(x_{p+1}, u, v, h_{p+1})$  or  $I_{p+1} \subset I_R(x_{p+1}, u, v, h_{p+1})$ .*
- *For  $1 \leq j \leq p$ , either  $I_j = I_S(x_j, u, v, h_j)$  or  $I_j = I_R(x_j, u, v, h_j)$ .*
- *If  $I_j = I_R(x_j, u, v, h_j)$ , then  $I_{j+1} = I_S(x_{j+1}, u, v, h_{j+1})$  with  $x_{j+1} = \begin{cases} x_j + u - v & \text{if } \text{Slope}(u + v) > 0 \\ x_j - u + v & \text{if } \text{Slope}(u + v) < 0 \end{cases}$ .*
- *If  $I_j = I_S(x_j, u, v, h_j)$  and  $I_{j+1} = I_R(x_{j+1}, u, v, h_{j+1})$ , then  $x_{j+1} = x_j + u + v$ .*
- *If  $I_j = I_S(x_j, u, v, h_j)$  and  $I_{j+1} = I_S(x_{j+1}, u, v, h_{j+1})$ , then  $x_{j+1} = x_j + u + v$ .*



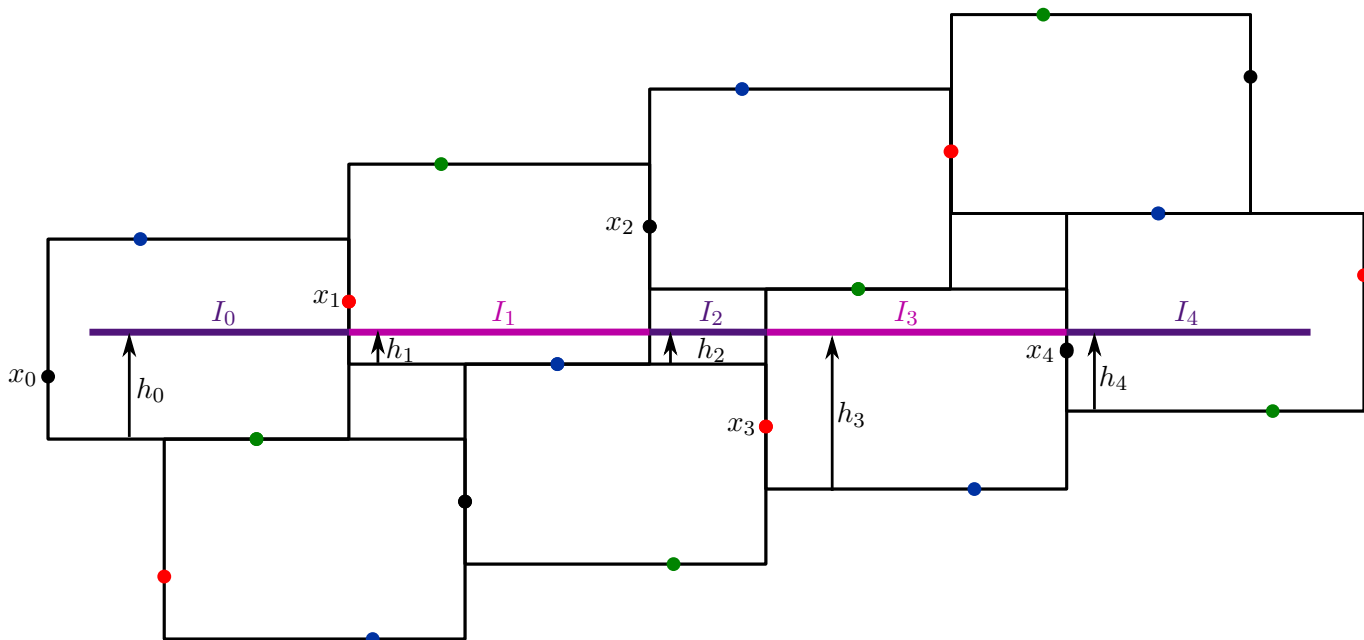

Figure 8.25: Decomposition of a horizontal segment

Moreover, suppose  $j < j'$ , then  $I_j \cap I_{j'} \neq \emptyset$  if and only if  $j' = j + 1$  and in this case  $I_j \cap I_{j+1}$  is a point (which is the endpoint of  $I_j$  and the starting point of  $I_{j+1}$ ).

See figure 8.25 on page 112 for an illustration of Lemma 8.13.

*Proof.* This lemma follows directly from Lemma 8.10. Lemma 8.10 gives a tiling of  $\mathbb{R}^2$  using the rectangles  $S(x, u, v)$  and  $R(x, u, v)$  for  $x \in \Lambda(t) \cup \Lambda(\bar{t})$ . Then we consider the intersection of  $I$  with this tiling, and this gives the decomposition  $I = I_0 \cup I_1 \cup \dots \cup I_p \cup I_p$ .

The third point comes from the fact that a rectangle  $R(x, u, v)$  is surrounded by four rectangles of the form  $S(y, u, v)$ , so a segment of the form  $I_R(x, u, v, h)$  cannot be followed by a segment of the form  $I_R(x', u, v, h')$ . □

We easily deduce from Lemma 8.13 the following properties :

**Corollary 8.14.** *With the notations of the previous Lemma, we have :*

1.  $\#\{j \in \{1, \dots, p\} \mid I_j = I_S(x_j, u, v, h_j)\} \geq \#\{j \in \{1, \dots, p\} \mid I_j = I_R(x_j, u, v, h_j)\}$
2. *The type of  $x_j$  is alternating. Precisely : if  $x_0$  is of type  $t$ , then  $x_j$  is of type  $t$  if  $j$  is even and of type  $\bar{t}$  if  $j$  is odd, and if  $x_0$  is of type  $\bar{t}$ , then  $x_j$  is of type  $\bar{t}$  if  $j$  is even and of type  $t$  if  $j$  is odd.*

Finally, we decompose any horizontal segment  $I$  using the tiling in the case where  $\text{Slope}(u + v)$  and  $\text{Slope}(v - u)$  are of the same sign.

**Lemma 8.15.** *Assume that  $\text{Slope}(u+v) \neq 0$ ,  $\text{Slope}(v-u) \neq \infty$  and that  $\text{Slope}(u+v)$  and  $\text{Slope}(v-u)$  are of the same sign.*

*Let  $t$  be a type and let  $I$  be a horizontal segment which does not intersect the lattice  $\Lambda$ .*

*There exist  $p \in \mathbb{N}$  such that for all  $0 \leq j \leq p+1$ , there exists a point  $x_j \in \Lambda(t) \cup \Lambda(\bar{t})$  and a real  $0 < h_j < 1$  such that :*

$$I = I_0 \cup I_1 \cup \dots \cup I_p \cup I_{p+1}$$

with

- $I_0 \subset I_S(x_0, u, v, h_0)$  and  $I_{p+1} \subset I_S(x_{p+1}, u, v, h_{p+1})$ .
- For all  $1 \leq j \leq p$ ,  $I_j = I_S(x_j, u, v, h_j)$ .
- Either  $x_{j+1} = x_j + u + v$ , and in this case  $I_j \cap I_{j+1}$  is a point (which is the right endpoint of  $I_j$  and the left endpoint of  $I_{j+1}$ ),
- Or  $x_{j+1} = \begin{cases} x_j + 2u & \text{if } \text{Slope}(u+v) > 0 \\ x_j + 2v & \text{if } \text{Slope}(u+v) < 0 \end{cases}$ , and in this case  $I_j \cap I_{j+1} = I_j \cap S^+(x_j, u, v)$ .

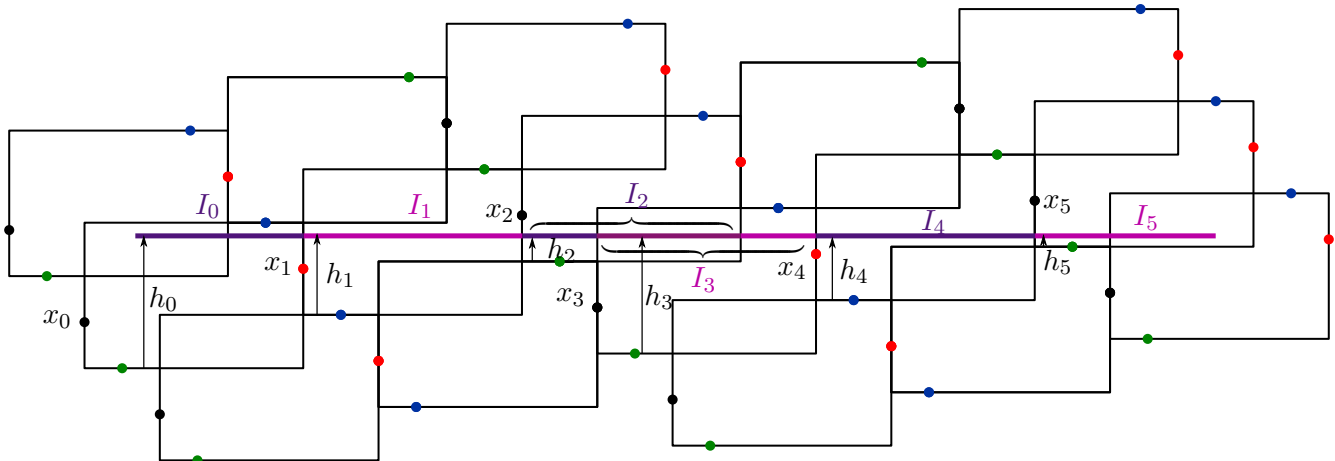

Figure 8.26: Decomposition of a horizontal segment

*Proof.* This Lemma follows directly from Lemma 8.9. Lemma 8.9 gives a "tiling" of  $\mathbb{R}^2$  (the term is improper in this context because the tiles can intersect in their interiors) using the rectangles  $S(x, u, v)$  for  $x \in \Lambda(t) \cup \Lambda(\bar{t})$ . Then we consider the intersection of  $I$  with this tiling, and this gives the desired decomposition  $I = I_0 \cup I_1 \cup \dots \cup I_p \cup I_{p+1}$ .  $\square$

## 8.5 A few reminders about *Farey neighbours*

In the next section, we will in particular consider a lattice in  $\mathbb{R}^2$  defined using the continued fraction expansion of a rational corresponding to a slope of a curve. Then we now need to say a few things about fractions, *Farey neighbours* and the link with continued fraction expansion.

In this section, we will consider fractions  $\frac{p}{q}$ , and we will always assume that they are written as irreducible fractions (which means that  $p$  and  $q$  are coprime) with non-negative denominator. By convention, we also consider the fraction  $\frac{1}{0}$  which we will sometimes refer to as  $+\infty$ .

We say that two distinct fractions  $\frac{p}{q}$  and  $\frac{p'}{q'}$ , are *Farey neighbours* whenever  $|pq' - p'q| = 1$ . This is equivalent to saying that the two vectors  $(q, p)$  and  $(q', p')$  form a basis of  $\mathbb{Z}^2$ . In this case, we denote by  $\frac{p}{q} \oplus \frac{p'}{q'}$  the *Farey sum* of the two fractions  $\frac{p}{q}$  and  $\frac{p'}{q'}$ , which is defined by  $\frac{p}{q} \oplus \frac{p'}{q'} = \frac{p+p'}{q+q'}$  (note that this last fraction is automatically irreducible with positive denominator). The fractions  $\frac{p}{q}$  and  $\frac{p}{q} \oplus \frac{p'}{q'}$  are also Farey neighbours, and so are  $\frac{p'}{q'}$  and  $\frac{p}{q} \oplus \frac{p'}{q'}$ . Suppose that  $qq' \neq 0$  and  $\frac{p}{q} \leq \frac{p'}{q'}$ . Then we have :

$$\frac{p}{q} \leq \frac{p}{q} \oplus \frac{p'}{q'} \leq \frac{p'}{q'}.$$

Now define  $\frac{p}{q} \ominus \frac{p'}{q'} = \frac{p-p'}{q-q'}$ . The fractions  $\frac{p}{q} \ominus \frac{p'}{q'}$  and  $\frac{p}{q}$  are Farey neighbours, and so are  $\frac{p}{q} \ominus \frac{p'}{q'}$  and  $\frac{p'}{q'}$ . Note that with this definition  $\ominus$  is commutative.

We have either  $(\frac{p}{q} \ominus \frac{p'}{q'}) \oplus \frac{p'}{q'} = \frac{p}{q}$  or  $(\frac{p'}{q'} \ominus \frac{p}{q}) \oplus \frac{p}{q} = \frac{p'}{q'}$ .

### Link with continued fraction expansion.

Let  $n_1 \in \mathbb{Z}, n_2, \dots, n_r \in \mathbb{N}^*$  with  $n_r \geq 2$ . Denote  $\frac{p}{q} = [n_1, \dots, n_r]$ ,  $\frac{p_0}{q_0} = \frac{1}{0}$  and for all  $1 \leq i \leq r$ ,  $\frac{p_i}{q_i} = [n_1, \dots, n_i]$ . Then, it is not hard to check that for all  $1 \leq i \leq r$ ,  $\frac{p_i}{q_i}$  and  $\frac{p_{i-1}}{q_{i-1}}$  are Farey-neighbours. We can compute their Farey sum and Farey difference and we obtain :

$$\begin{aligned} \frac{p_i}{q_i} \oplus \frac{p_{i-1}}{q_{i-1}} &= [n_1, \dots, n_i + 1] \\ \frac{p_i}{q_i} \ominus \frac{p_{i-1}}{q_{i-1}} &= \begin{cases} [n_1, \dots, n_i - 1] & \text{if } n_i \geq 2 \text{ or } i = 1 \\ [n_1, \dots, n_{i-2}] & \text{if } n_i = 1 \text{ and } i \geq 3 \\ \frac{1}{0} = \infty & \text{if } n_i = 1 \text{ and } i = 2 \end{cases} [n_1, \dots, n_i - 1] \end{aligned}$$

Notice that in this case we always have  $(\frac{p_i}{q_i} \ominus \frac{p_{i-1}}{q_{i-1}}) \oplus \frac{p_{i-1}}{q_{i-1}} = \frac{p_i}{q_i}$ .

Let us make two observations :

$$\frac{p_i}{q_i} \oplus \frac{p_{i-1}}{q_{i-1}} \neq \frac{p}{q} \tag{8.10}$$

$$\frac{p_i}{q_i} \ominus \frac{p_{i-1}}{q_{i-1}} = -1 \text{ if and only if } i = 1 \text{ and } n_i = 0 \tag{8.11}$$

Moreover, since  $\frac{p}{q} = [n_1, \dots, n_r]$ , we either have  $[n_1, \dots, n_i+1] \leq [n_1, \dots, n_r] \leq [n_1, \dots, n_i]$  or  $[n_1, \dots, n_i] \leq [n_1, \dots, n_r] \leq [n_1, \dots, n_i+1]$ , that is :

$$\text{either } \frac{p_i}{q_i} \oplus \frac{p_{i-1}}{q_{i-1}} \leq \frac{p}{q} \leq \frac{p_i}{q_i} \quad \text{or} \quad \frac{p_i}{q_i} \leq \frac{p}{q} \leq \frac{p_i}{q_i} \oplus \frac{p_{i-1}}{q_{i-1}}.$$

- If  $\frac{p_i}{q_i} \oplus \frac{p_{i-1}}{q_{i-1}} \leq \frac{p}{q} \leq \frac{p_i}{q_i}$ , this forces  $\frac{p_{i-1}}{q_{i-1}} \leq \frac{p_i}{q_i} \oplus \frac{p_{i-1}}{q_{i-1}} \leq \frac{p_i}{q_i}$  and so  $\frac{p_i}{q_i} \ominus \frac{p_{i-1}}{q_{i-1}} \geq \frac{p_i}{q_i} \geq \frac{p}{q}$ .  
Hence  $\frac{p_i}{q_i} \oplus \frac{p_{i-1}}{q_{i-1}} \leq \frac{p}{q} \leq \frac{p_i}{q_i} \ominus \frac{p_{i-1}}{q_{i-1}}$ .
- If  $\frac{p_i}{q_i} \leq \frac{p}{q} \leq \frac{p_i}{q_i} \oplus \frac{p_{i-1}}{q_{i-1}}$ , this forces  $\frac{p_i}{q_i} \leq \frac{p_i}{q_i} \oplus \frac{p_{i-1}}{q_{i-1}} \leq \frac{p_{i-1}}{q_{i-1}}$  and so  $\frac{p_i}{q_i} \ominus \frac{p_{i-1}}{q_{i-1}} \leq \frac{p_i}{q_i} \leq \frac{p}{q}$ .  
Hence  $\frac{p_i}{q_i} \ominus \frac{p_{i-1}}{q_{i-1}} \leq \frac{p}{q} \leq \frac{p_i}{q_i} \oplus \frac{p_{i-1}}{q_{i-1}}$ .

Thus, in every case, the rationals  $\frac{p_i}{q_i} \ominus \frac{p_{i-1}}{q_{i-1}}$  and  $\frac{p_i}{q_i} \oplus \frac{p_{i-1}}{q_{i-1}}$  are on either side of  $\frac{p}{q}$ .

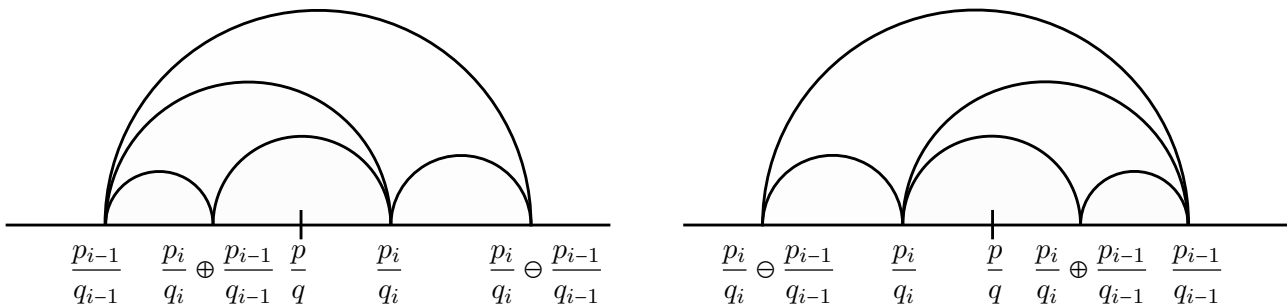

Figure 8.27: The rational  $\frac{p}{q}$  and its approximants  $\frac{p_i}{q_i}, \frac{p_{i-1}}{q_{i-1}}, \frac{p_i}{q_i} \oplus \frac{p_{i-1}}{q_{i-1}}$  and  $\frac{p_i}{q_i} \ominus \frac{p_{i-1}}{q_{i-1}}$  ordered on the real line.

## 8.6 Magic-lengths Proposition

For  $\gamma$  a primitive element in  $\mathbb{F}_2$  of slope  $[n_1(\gamma), \dots, n_{r(\gamma)}(\gamma)]$ , recall that we have defined the lengths  $l_i(\gamma)$  and  $l'_i(\gamma)$ , for  $0 \leq i \leq r(\gamma)$ , in Definition 4.1 :  $l_i(\gamma)$  and  $l'_i(\gamma)$  are respectively the (cyclically reduced) lengths of any primitive element in  $\mathbb{F}_2$  of slope  $[n_1(\gamma), \dots, n_i(\gamma)]$  and  $[n_1(\gamma), \dots, n_i(\gamma) + 1]$ . For  $\gamma$  a simple closed curve in  $\pi_1(S_{0,4})$  of slope  $[n_1(\gamma), \dots, n_{r(\gamma)}(\gamma)]$ , we define for all  $0 \leq i \leq r(\gamma)$ ,  $l_i(\gamma)$  and  $l'_i(\gamma)$  to be the lengths of any primitive element in  $\mathbb{F}_2$  of slope  $[n_1(\gamma), \dots, n_i(\gamma)]$  and  $[n_1(\gamma), \dots, n_i(\gamma) + 1]$  respectively. Then, the length of  $\gamma \in \mathcal{S}(S_{0,4})$  is  $|\gamma| = 2l_{r(\gamma)}(\gamma)$ , and more generally, for all  $0 \leq i \leq r(\gamma)$ , the length of any simple closed curve of  $S_{0,4}$  of slope  $[n_1(\gamma), \dots, n_i(\gamma)]$  is  $2l_i(\gamma)$ . Notice that, for  $\gamma \in \mathcal{P}(\mathbb{F}_2)$  or for  $\gamma \in \mathcal{S}(S_{0,4})$ ,  $l_i(\gamma)$  only depends on the slope of  $\gamma$  (and of the integer  $i$ ).

In Lemma 4.6, we proved that subwords of some specific lengths (precisely the lengths  $l_i(\gamma)$ ) of primitive elements  $\gamma$  in  $\mathbb{F}_2$  are themselves primitive (up to a change of letter). In the context of the four-punctured sphere, we do not prove the same result but we prove that subwords of some specific lengths (precisely  $l_i(\gamma) - 5$ ) of  $\gamma \in \mathcal{S}(S_{0,4})$  are redundant in the sense that they and their inverses can be found many other times in the word  $\gamma$ . This is the purpose of the following proposition :

**Proposition 8.16.** *Set  $\alpha = \frac{1}{30}$ .*

*Let  $\gamma \in \mathcal{S}(S_{0,4})$ . Consider  $\text{Slope}(\gamma) = [n_1(\gamma), \dots, n_{r(\gamma)}(\gamma)]$  the continued fraction expansion of  $\text{Slope}(\gamma)$ . Fix  $0 \leq i \leq r(\gamma)$  such that  $l_i(\gamma) \geq 10$  (in particular, note that by (4.9), this condition is fulfilled whenever  $i \geq 10$ ).*

*Let  $W \in \mathbb{F}_3$  be a subword of (a cyclic-permutation of)  $\gamma$  (or its inverse) such that  $|W| \geq 3(l'_i(\gamma) + l_i(\gamma) + 1)$  and  $w \in \mathbb{F}_3$  be a subword of (a cyclic-permutation of)  $\gamma$  (or its inverse) of length  $l_i(\gamma) - 5$ . Then we can write the word  $W$  as a concatenation as follow :*

$$W = u_1 \cdots u_q$$

*such that there exists a subset  $\mathcal{I} \subset \{1, \dots, q\}$  satisfying the following :*

1. *For all  $k \in \mathcal{I}$ ,  $u_k \in \{w, w^{-1}\}$ .*
2.  $\sum_{k \in \mathcal{I}} |u_k| \geq \alpha |W|$ .

We will prove Proposition 8.16 in section 8.6.4. For this purpose, given a simple closed curve  $\gamma \in \mathcal{S}(S_{0,4})$  and a fixed integer  $0 \leq i \leq r(\gamma)$ , we will define in section 8.6.1 a lattice  $\Lambda$  of  $\mathbb{R}^2$  together with a basis  $(u, v)$  of  $\Lambda$  which will be particularly convenient for studying subwords of  $\gamma$  of length  $l_i(\gamma)$ . This will allow us to "read" the word  $\gamma$  by following a horizontal line in  $\mathbb{R}^2$  (section 8.6.2) and then we will consider for this specific choice of  $\Lambda$  and  $(u, v)$  the tiles  $S(x, u, v)$  of  $\mathbb{R}^2$  defined in section 8.4 to study some specific subwords of  $\gamma$  : the one read in the rectangle  $S(x, u, v)$ , which will be of lengths approximately  $l'_i(\gamma)$  (section 8.6.3).

### 8.6.1 A tiling of $\mathbb{R}^2$

In this section, we associate to a simple closed curve  $\gamma \in \mathcal{S}(S_{0,4})$  and an integer  $1 \leq i \leq r(\gamma)$  a lattice  $\Lambda$  of  $\mathbb{R}^2$ .

Fix  $\gamma \in \mathcal{S}(S_{0,4})$  a simple closed curve. Let us assume that  $\text{Slope}(\gamma) \geq 0$  and write  $[n_1, \dots, n_r] = \text{Slope}(\gamma)$  the continued fraction expansion of  $\text{Slope}(\gamma)$ . For  $1 \leq i < r$ , we write  $\frac{p_i}{q_i} = [n_1, \dots, n_i]$  and

for  $i = 0$ ,  $\frac{p_0}{q_0} = \frac{1}{0}$ . Now we fix  $1 \leq i < r$  for all this section and if  $i = 1$ , we assume that  $n_i \neq 0$ .

Denote  $u = (q_i, p_i) \in \mathbb{Z}^2$  and  $v = (q_{i-1}, p_{i-1}) \in \mathbb{Z}^2$ . Notice that, because of the assumption  $i < r$ , we have  $\text{Slope}(u) \neq \text{Slope}(\gamma)$  and  $\text{Slope}(v) \neq \text{Slope}(\gamma)$ . After possibly exchanging  $u$  and  $v$ , suppose that  $\text{Slope}(u) < \text{Slope}(\gamma)$ . Then, we have :

1.  $\text{Slope}(u) < \text{Slope}(\gamma) < \text{Slope}(v)$ .
2.  $(u, v)$  form a basis of  $\mathbb{Z}^2$

Moreover, using the equalities (8.10) and (8.11) of section 8.5 and the hypothesis  $(i, n_i) \neq (1, 0)$ , we have :

3.  $\text{Slope}(u + v) = \frac{p_i}{q_i} \oplus \frac{p_{i-1}}{q_{i-1}} \neq \text{Slope}(\gamma)$
4.  $\text{Slope}(v - u) = \frac{p_i}{q_i} \ominus \frac{p_{i-1}}{q_{i-1}} \neq -1$

Let us write as irreducible fractions :

$$\frac{p}{q} = \text{Slope}(\gamma), \quad \frac{p_i}{q_i} = \text{Slope}(u), \quad \frac{p'_i}{q'_i} = \text{Slope}(v)$$

**The map  $f_{\gamma, u, v}$ .**

Consider  $f_{\gamma, u, v}$  an element of  $\text{GL}(2, \mathbb{R})$  which sends the lines of slope  $\text{Slope}(\gamma)$  in  $\mathbb{R}^2$  to the lines of slope 0 and the lines of slope  $-1$  in  $\mathbb{R}^2$  to the lines of slope  $+\infty$ . Choose  $f_{\gamma, u, v}$  such that  $f_{\gamma, u, v}$  preserves the orientation, and scale it so that the abscissa of the vector  $f_{\gamma, u, v}(u + v)$  is 1 and the ordinate of the vector  $f_{\gamma, u, v}(v - u)$  is also 1 (such a map always exists). Let us give  $f_{\gamma, u, v}$  explicitly. The map  $f_{\gamma, u, v}$  is the product of a diagonal matrix  $D$  with a matrix  $M$  which sends lines of slope  $-1$  to lines of slope  $+\infty$  and lines of slope  $\frac{p}{q}$  to lines of slope 0. Therefore

for  $M$  we can choose the inverse of the matrix  $\begin{pmatrix} q & -1 \\ p & 1 \end{pmatrix}$  which gives  $M = \frac{1}{p+q} \begin{pmatrix} 1 & 1 \\ -p & q \end{pmatrix}$ . Then

$Mu = \frac{1}{p+q} \begin{pmatrix} p_i + q_i \\ -pq_i + qp_i \end{pmatrix}$  and  $Mv = \frac{1}{p+q} \begin{pmatrix} p'_i + q'_i \\ -pq'_i + qp'_i \end{pmatrix}$  and in order to get the right rescaling we

need to impose :  $D = (p+q) \begin{pmatrix} \frac{1}{p_i+q_i+p'_i+q'_i} & 0 \\ 0 & \frac{1}{p(q_i-q'_i)-q(p_i-p'_i)} \end{pmatrix}$ . Hence we obtain :

$$f_{\gamma, u, v} = \begin{pmatrix} \frac{1}{p_i+q_i+p'_i+q'_i} & \frac{1}{p_i+q_i+p'_i+q'_i} \\ \frac{-p}{p(q_i-q'_i)-q(p_i-p'_i)} & \frac{q}{p(q_i-q'_i)-q(p_i-p'_i)} \end{pmatrix} \quad (8.12)$$

Also note that  $(p_i + q_i, p'_i + q'_i) \in \{(l_i(\gamma), l_{i-1}(\gamma)), (l_{i-1}(\gamma), l_i(\gamma))\}$  and then  $p_i + q_i + p'_i + q'_i = l_i(\gamma) + l_{i-1}(\gamma) = l'_i(\gamma)$ . Now we can compute  $f_{\gamma,u,v}(u)$  and  $f_{\gamma,u,v}(v)$  :

$$f_{\gamma,u,v}(u) = \left( \frac{p_i + q_i}{p_i + q_i + p'_i + q'_i}, \frac{-pq_i + qp_i}{p(q_i - q'_i) - q(p_i - p'_i)} \right)$$

$$f_{\gamma,u,v}(v) = \left( \frac{p'_i + q'_i}{p_i + q_i + p'_i + q'_i}, \frac{-pq'_i + qp'_i}{p(q_i - q'_i) - q(p_i - p'_i)} \right)$$

We deduce :

$$\max((f_{\gamma,u,v}(u))_1, (f_{\gamma,u,v}(v))_1) = \frac{\max(p_i + q_i, p'_i + q'_i)}{p_i + q_i + p'_i + q'_i} = \frac{\max(l_i(\gamma), l_{i-1}(\gamma))}{l'_i(\gamma)} = \frac{l_i(\gamma)}{l'_i(\gamma)} \quad (8.13)$$

Since we have  $\text{Slope}(u) < \text{Slope}(\gamma) < \text{Slope}(v)$ , we deduce that  $\text{Slope}(f_{\gamma,u,v}(u)) < 0 < \text{Slope}(f_{\gamma,u,v}(v))$ . We had also noticed that  $\text{Slope}(u+v) \neq \text{Slope}(\gamma)$  and  $\text{Slope}(v-u) \neq -1$ , hence we can also deduce that

$$\text{Slope}(f_{\gamma,u,v}(u+v)) \neq 0 \quad (8.14)$$

$$\text{Slope}(f_{\gamma,u,v}(v-u)) \neq \infty \quad (8.15)$$

Note also that the slope of  $f_{\gamma,u,v}(u+v)$  and  $f_{\gamma,u,v}(v-u)$  are of opposite signs. Indeed, before applying the map  $f_{\gamma,u,v}$ , the slope of  $u+v$  is  $\frac{p_i}{q_i} \oplus \frac{p_{i-1}}{q_{i-1}}$  and the slope of  $v-u$  is  $\frac{p_i}{q_i} \ominus \frac{p_{i-1}}{q_{i-1}}$ . By the result of the end of section 8.5, the rationals  $\frac{p_i}{q_i} \oplus \frac{p_{i-1}}{q_{i-1}}$  and  $\frac{p_i}{q_i} \ominus \frac{p_{i-1}}{q_{i-1}}$  are on either side of  $\frac{p}{q}$ , (with  $\frac{p}{q}$  the slope of  $\gamma$ ), hence after applying the map  $f_{\gamma,u,v}$ , we deduce that these two slopes are of opposite signs, since the slope  $\frac{p}{q}$  is sent to 0 by  $f_{\gamma,u,v}$ .

The map  $f_{\gamma,u,v}$  sends the lattice  $\mathbb{Z}^2$  to another lattice in  $\mathbb{R}^2$ , denote it by  $\Lambda = f_{\gamma,u,v}(\mathbb{Z}^2)$ . Hence  $2\Lambda = f_{\gamma,u,v}(2\mathbb{Z}^2)$ . Recall that we had defined the type of a point in  $\mathbb{Z}^2$ , we can then also define the *type* of a point in  $\Lambda$  as the type of the corresponding point in  $\mathbb{Z}^2$ . We obtain four types of points in  $\Lambda$  given by the four classes of the elements of  $\Lambda \bmod 2\Lambda$ . We had also defined three sets of lines :  $L_A, L_B$  and  $L_C$  so we can look at their images by  $f_{\gamma,u,v}$ . Since the lines in  $L_C$  have slope  $-1$ , the lines in  $f_{\gamma,u,v}(L_C)$  have slope  $+\infty$ . Also note that a line of slope  $\text{Slope}(\gamma)$  has for image a line of slope 0. Thus the lines in  $f_{\gamma,u,v}(L_A)$  have a negative slope and the lines in  $f_{\gamma,u,v}(L_B)$  have a positive slope (recall that the lines in  $L_A$  have slope 0 and the lines in  $L_B$  have slope  $+\infty$ ). Two non parallel lines in  $f_{\gamma,u,v}(L_A) \cup f_{\gamma,u,v}(L_B) \cup f_{\gamma,u,v}(L_C)$  always intersect in a point of  $\Lambda$ .

In order to simplify the notation, from now on we simply denote by  $L_A, L_B, L_C, u, v$  the images of  $L_A, L_B, L_C, u, v$  by  $f_{\gamma,u,v}$ .

Now that the lattice  $\Lambda$  is fixed as well as the basis  $(u, v)$  of  $\Lambda$  satisfying  $\text{Slope}(u) < 0 < \text{Slope}(v)$ , we can use the notations of section 8.4 to talk about the rectangle  $S(x, u, v)$  and  $R(x, u, v)$ , for a point  $x \in \Lambda$ .

Note that, by the choice of the scaling of  $f_{\gamma,u,v}$ , the lengths of the sides of  $S(x, u, v)$  are 1.

### 8.6.2 Reading the word $\gamma$ and its subwords

We can still read the word corresponding to  $\gamma$  in the fundamental group  $\pi_1(S_{0,4})$  using the lattice  $\Lambda$  and the three new sets of lines  $L_A, L_B$  and  $L_C$  : Follow a line  $l_0$  of slope 0 in  $\mathbb{R}^2$  which avoids the lattice  $\Lambda$  and record  $a, b$  or  $c$  each time the line  $l_0$  crosses a line  $l$  of  $L_A, L_B$  or  $L_C$  with power  $\pm 1$  depending on the transverse orientation of  $l$  at the intersection point with  $l_0$ . To obtain the full word  $\gamma$  (more precisely a cyclic permutation of  $\gamma$  or its inverse), we have to follow  $l_0$  between two points which are identified by an element of  $2\mathcal{P}(\Lambda)$ , that is between two points  $x$  and  $y$  on  $l_0$  such that  $y = x + 2\lambda$ , with  $\lambda \in \mathcal{P}(\Lambda)$  (here  $\mathcal{P}(\Lambda)$  denotes the set of primitive elements in  $\Lambda$ , that is the elements in  $\Lambda$  which can be completed to a basis of  $\Lambda$ ). More generally, by following  $l_0$  along a segment  $I \subset [x, y] \subset l_0$ , we read a subword of  $\gamma$  (or a subword of a cyclic-permutation of  $\gamma$  or its inverse). We denote by  $W(I)$  this subword. We are now interested in the link between the length of the segment  $I$  and the word length of the word  $W(I)$  we read by following  $I$ . More precisely, we need the following lemma :

**Lemma 8.17.** *Let  $W$  be a subword of  $\gamma$  (or more generally a subword of a cyclic permutation of  $\gamma$  or its inverse). There exists a horizontal segment  $I$  in the plane  $\mathbb{R}^2$  such that we read  $W$  by following  $I$  and, denoting  $l(I)$  the length of the segment  $I$  and  $|W|$  the word length of  $W$ , we have :*

$$|W| - 3 \leq l(I)l'_i(\gamma) \leq |W| + 1$$

Remember that the integer  $i$  which appears in this Lemma 8.17 has been fixed at the beginning of section 8.6.1. Everything that has been defined using  $i$ , therefore depends on it : the map  $f_{\gamma,u,v}$ , the lattice  $\Lambda$ , the three sets of lines  $L_A, L_B$  and  $L_C$ , etc... We have chosen not to index these objects by  $i$  in order to reduce the amount of notation.

*Proof.* Let us start by computing the spacing between two consecutive lines in  $L_C$ , and denote it by  $E_C$ . Recall that  $L_C$  consists of parallel lines of slope  $+\infty$  which are the images of the lines of equations  $y = -x + 2k, k \in \mathbb{Z}$ , under the map  $f_{\gamma,u,v}$ . Then, since the point  $(x, y) = (\frac{2q}{p+q}, \frac{2p}{p+q})$  belongs both to the line of equation  $y = -x + 2$  and to the line of equation  $y = \frac{p}{q}x$ , its image by  $f_{\gamma,u,v}$  belongs both to the line of equation  $y = 0$  and to the line of equation  $x = E_C$ . We compute  $f_{\gamma,u,v}(x, y)$  and we obtain  $(\frac{2}{l'_i(\gamma)}, 0)$ . Hence  $E_C = \frac{2}{l'_i(\gamma)}$ .

Now, since  $W$  is a subword of  $\gamma$ , we can read it somewhere following a subsegment  $I$  of  $l_0$ , that is a horizontal segment. Now remember that since  $\text{Slope}(\gamma) \geq 0$ , the letters of  $\gamma$  alternate between letters in  $\{c, c^{-1}\}$  and letters in  $\{a, a^{-1}, b, b^{-1}\}$ . This means that  $I$  crosses exactly one line in  $L_A \cup L_B$  between two lines in  $L_C$ . Denote  $n_C$  the number of intersection points between  $I$  and  $L_C$ , or equivalently the number of  $c$  and  $c^{-1}$  in  $W$ .

- If  $|W|$  is even, then  $|W| = 2n_C$ , and we can choose  $I$  such that :

$$(n_C - 1)E_C \leq l(I) \leq n_C E_C, \quad \text{which is equivalent to} \quad (|W| - 2)E_C \leq 2l(I) \leq |W|E_C.$$

- If  $|W|$  is odd and  $|W| = 2n_C + 1$ , then we can choose  $I$  such that :

$$(n_C - 1)E_C \leq l(I) \leq (n_C + 1)E_C, \quad \text{which is equivalent to} \quad (|W| - 3)E_C \leq 2l(I) \leq (|W| + 1)E_C.$$



- If  $|W|$  is odd and  $|W| = 2n_C - 1$ , then we can choose  $I$  such that :

$$l(I) = n_C E_C, \quad \text{which is equivalent to} \quad 2l(I) = (|W| + 1)E_C.$$

Therefore, in every cases we have

$$(|W| - 3)E_C \leq 2l(I) \leq (|W| + 1)E_C$$

and using the previously calculated value of  $E_C$ , we obtain the required inequality.  $\square$

### 8.6.3 Subwords associated to a square

By the previous construction, following  $l_0$  along the segment  $I$  gives (a cyclic permutation of) the word  $\gamma$  (or its inverse). Hence by following a subsegment of  $I$ , we obtain a subword of  $\gamma$ . Recall that  $\text{Slope}(u+v)$  and  $\text{Slope}(v-u)$  are of opposite signs. We will now look at the subwords of  $\gamma$  that we obtain by crossing a square  $S(x, u, v)$  and a rectangle  $R(x, u, v)$ , that is by following the intervals  $I_S(x, u, v, h)$  and  $I_R(x, u, v, h)$ .

Now assume that the real  $h$  ( $\in (0, 1)$ ) is such that the segment  $I_S(x, u, v, h)$  (respectively  $I_R(x, u, v, h)$ ) does not intersect the lattice  $\Lambda$  and therefore, let us define  $W_S(x, u, v, h)$  (respectively  $W_R(x, u, v, h)$ ) to be the subword of  $\gamma$  read when following  $I_S(x, u, v, h)$  (respectively  $I_R(x, u, v, h)$ ). There is a small ambiguity that we must resolve : if one of the endpoints of  $I_S(x, u, v, h)$  (resp.  $I_R(x, u, v, h)$ ) is an intersection point of  $I_S(x, u, v, h)$  (resp.  $I_R(x, u, v, h)$ ) with a line in  $L_A \cup L_B \cup L_C$ , then we record the corresponding letter in  $W_S(x, u, v, h)$  (resp.  $W_S(x, u, v, h)$ ). Now let us make a simple but important observation : because of the invariance of our setting by the action of  $2\Lambda$ , if  $x$  and  $x'$  are two points of  $\Lambda$  of the same type, then  $W_S(x, u, v, h) = W_S(x', u, v, h)$  and  $W_R(x, u, v, h) = W_R(x', u, v, h)$ . Hence the subword of  $\gamma$  read in a square or a rectangle only depends on the type of the square and the height  $h$ . So if  $t \in \Lambda/2\Lambda$  is the type of a point, we will write  $W_S(t, u, v, h)$  and  $W_R(t, u, v, h)$  without ambiguity.

The following lemma states that the subwords of  $\gamma$  read in some square (resp. rectangle) are the inverses of the subwords read in a square (resp. rectangle) of opposite type :

**Lemma 8.18.** *Let  $t \in \Lambda/2\Lambda$  be a type and  $\bar{t}$  its  $(u, v)$ -opposite type. Let  $0 < h < 1$  and  $0 < h' < u_2 + v_2$  such that if  $x$  is a point of  $\Lambda$  of type  $\bar{t}$ , then  $I_S(x, u, v, h)$  and  $I_R(x, u, v, h')$  does not intersect the lattice  $\Lambda$ . Then  $I_S(x + u + v, u, v, 1 - h)$  and  $I_R(x + u + v, u, v, u_2 + v_2 - h')$  does not intersect the lattice  $\Lambda$  and :*

$$\begin{aligned} W_S(\bar{t}, u, v, h) &= W_S(t, u, v, 1 - h)^{-1} \\ W_R(\bar{t}, u, v, h') &= W_R(t, u, v, u_2 + v_2 - h')^{-1} \end{aligned}$$

*Proof.* Let  $x$  be a point of  $\Lambda$  of type  $\bar{t}$ . Consider the reflection of the square  $S(x, u, v)$  (resp. rectangle  $R(x, u, v)$ ) across the point  $x + u + v$  (resp.  $x + u$ ). This gives the square  $S(x + u + v, u, v)$  (resp. rectangle  $R(x + u + v, u, v)$ ), and then this square (resp. rectangle) is of type  $t$ . Now consider

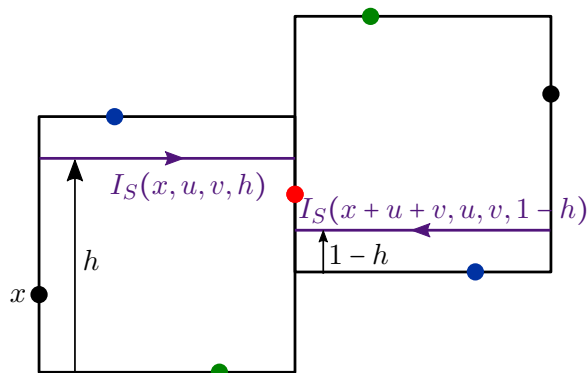

Figure 8.28: Proof of Lemma 8.18

the segment  $I_S(x, u, v, h)$  in  $S(x, u, v)$  (resp.  $I_R(x, u, v, h')$  in  $R(x, u, v)$ ) with its orientation from left to right. Then its reflection across the point  $x + u + v$  (resp.  $x + u$ ) is the segment  $I_S(x + u + v, u, v, 1 - h)$  in  $S(x + u + v, u, v)$  (resp.  $I_R(x + u + v, u, v, u_2 + v_2 - h')$  in  $R(x + u + v, u, v)$ ) with the reverse orientation : from right to left. Since our setting is invariant under a reflection across a point of the lattice  $\Lambda$ , we deduce that the subword read by following  $I_S(x, u, v, h)$  (resp.  $I_R(x, u, v, h')$ ) from left to right is the same as the subword read by following  $I_S(x + u + v, u, v, 1 - h)$  (resp.  $I_R(x + u + v, u, v, u_2 + v_2 - h')$ ) from right to left, thus it is the inverse of the subword read by following  $I_S(x + u + v, u, v, 1 - h)$  (resp.  $I_R(x + u + v, u, v, u_2 + v_2 - h')$ ) from left to right. Hence the lemma.  $\square$

Now we want to investigate the dependence on the height  $h$  of the word  $W_S(t, u, v, h)$ . Precisely, we want to show that, up to changing a few letters at the beginning and at the end of the word  $W_S(t, u, v, h)$ , it does not depend on the height  $h$ .

**Lemma 8.19.** *Let  $t \in \Lambda/2\Lambda$  be a type and  $h, h'$  be two heights. Then, up to adding a letter at the beginning of  $W_S(t, u, v, h)$ , or removing the first letter of  $W_S(t, u, v, h)$ , or changing the two first letters of  $W_S(t, u, v, h)$ , and up to adding a letter at the end of  $W_S(t, u, v, h)$ , or removing the last letter of  $W_S(t, u, v, h)$ , or changing the two last letters of  $W_S(t, u, v, h)$ , we have :*

$$W_S(t, u, v, h) = W_S(t, u, v, h')$$

*Proof.* Let  $x$  be a point of type  $t$  in  $\Lambda$ . We will work in the square  $S(x, u, v)$ . We want to understand the intersection of lines in  $L_A \cup L_B \cup L_C$  which occurs in the square  $S(x, u, v)$ . Let us prove the following fundamental observations :

1. If two lines of  $L_A \cup L_B \cup L_C$  intersect in  $S(x, u, v)$ , then they intersect in  $\{x, x+u, x+v, x+u+v\}$ .
2. If a line of  $L_A \cup L_B \cup L_C$  crosses the left side of the square  $S(x, u, v)$ , then it passes through the point  $x$ .
3. If a line of  $L_A \cup L_B \cup L_C$  crosses the right side of the square  $S(x, u, v)$ , then it passes through the point  $x + u + v$ .

*Proof of the observations.* 1. Two lines of  $L_A \cup L_B \cup L_C$  can only intersect in a point of the lattice  $\Lambda$ . But recall that the only points of the lattice  $\Lambda$  contained in  $S(x, u, v)$  are the four points  $x, x + u, x + v$  and  $x + u + v$ . Hence the first observation.

2. Consider  $L_\infty$  the set of vertical lines (of slope  $\infty$ ) which passes through a point of  $\Lambda$ . Of course  $L_C \subset L_\infty$ . Now note that if  $l \in L_\infty$  and  $l' \in L_A \cup L_B$ , then the intersection point between  $l$  and  $l'$  belongs to the lattice  $\Lambda$  :  $l \cap l' \subset \Lambda$ . Since  $x \in \Lambda$ , we deduce that the left vertical side of the square  $S(x, u, v)$  is included in a line  $l \in L_\infty$ . Therefore any line of  $L_A \cup L_B$  which crosses the left side of the square  $S(x, u, v)$  intersects it in a point of  $\Lambda$ . We conclude by recalling that  $x$  is the only point of the lattice  $\Lambda$  on the left vertical side of  $S(x, u, v)$ . To finish the proof, note that if a line of  $L_C$  crosses the left side of the square  $S(x, u, v)$ , it is trivial that it passes through the point  $x$ , since in that case the line would be vertical and hence would contained the left side of the square  $S(x, u, v)$ .

3. The proof is exactly the same as for the previous point, since the point  $x + u + v$  of the lattice  $\Lambda$  belongs to the right side of  $S(x, u, v)$  and is the only point of the lattice  $\Lambda$  on the right side of  $S(x, u, v)$ . □

From these three observations we can deduce the Lemma 8.19. Let us first draw a picture. Figure 8.29 on page 123 shows the square  $S(x, u, v)$  together with the lines of  $L_A \cup L_B \cup L_C$  that cross it. Lines in  $L_A$  are in green in the figure : they have negative slope and are regularly spaced. Lines in  $L_B$  are in blue in the figure : they have positive slope and are regularly spaced. Lines in  $L_C$  are in blue in the figure : they are vertical and regularly spaced. Note that between two lines in  $L_A \cup L_B$  there is always exactly one line in  $L_C$ .

Consider two heights  $h$  and  $h'$  and  $I_S(x, u, v, h)$  and  $I_S(x, u, v, h')$  the corresponding segments in  $S(x, u, v)$ . Let  $l$  and  $l'$  be two lines of  $L_A \cup L_B \cup L_C$  which cross the square  $S(x, u, v)$  but cross neither the left side nor the right side of  $S(x, u, v)$ . Then  $l$  and  $l'$  do not intersect in the interior of the square  $S(x, u, v)$ . Therefore, by following the segments  $I_S(x, u, v, h)$  and  $I_S(x, u, v, h')$  from left to right, we cross  $l$  and  $l'$  in the same order. Moreover, there is no point of the lattice  $\Lambda$  in the intersection of  $l$  and the interior of  $S(x, u, v)$ . So the segments  $I_S(x, u, v, h)$  and  $I_S(x, u, v, h')$  cross the line  $l$  with the same orientation. We deduce that the only differences between the words  $W(t, u, v, h)$  and  $W(t, u, v, h')$  must occur at the beginning and at the end of these words (and correspond to lines of  $L_A \cup L_B \cup L_C$  which passes through  $x$  and  $x + u + v$ ). Indeed, suppose  $h > -u_2$  and  $h' < -u_2$ , and let us distinguish according to the type of  $x$ , which is  $t$  :

- If  $t = a$ , then there is exactly one line of  $L_A \cup L_B \cup L_C$  passing through  $x$  and it is a line of  $L_A$ . Since the slope of the lines in  $L_A$  is negative, we deduce that we must add a letter at the beginning of  $W_S(x, u, v, h)$  (which will be  $a^{-1}$ ) to obtain the same beginning as the word  $W_S(x, u, v, h')$ .
- If  $t = b$ , then there is exactly one line of  $L_A \cup L_B \cup L_C$  passing through  $x$  and it is a line of  $L_B$ . Since the slope of the lines in  $L_B$  is positive, we deduce that we must add a letter at the beginning of  $W_S(x, u, v, h')$  (which will be  $b$ ) to obtain the same beginning as the word  $W_S(x, u, v, h)$ .

- If  $t = c$ , then there is exactly one line of  $L_A \cup L_B \cup L_C$  passing through  $x$  and it is a line of  $L_C$ . Since the slope of the lines in  $L_C$  is infinite, we deduce that we must change the sign of the first letter of  $W_S(x, u, v, h')$  (which will be  $c^{-1}$ ) to obtain the same beginning as the word  $W_S(x, u, v, h)$ .
- If  $t = abc$ , then there is exactly three lines of  $L_A \cup L_B \cup L_C$  passing through  $x$  : one in  $L_A$ , one in  $L_B$  and one in  $L_C$ . Then we deduce that after changing the sign of the first letter of  $W_S(x, u, v, h')$  (which will be  $c$ ) and changing the second letter of  $W_S(x, u, v, h')$  (from  $a$  to  $b^{-1}$ ), we recover the beginning of the word  $W_S(x, u, v, h)$ .

Now suppose that  $h > v_2$  and  $h' < v_2$ . By making the same distinction as before but this time on the type of  $x+u+v$  (which is  $\bar{t}$ ), we deduce as above that after possibly adding or removing a letter at the beginning of  $W_S(t, u, v, h)$ , or after possibly changing the two last letters of  $W_S(t, u, v, h)$ , the end of the word  $W_S(t, u, v, h)$  is the same as the end of the word  $W_S(t, u, v, h')$ .  $\square$

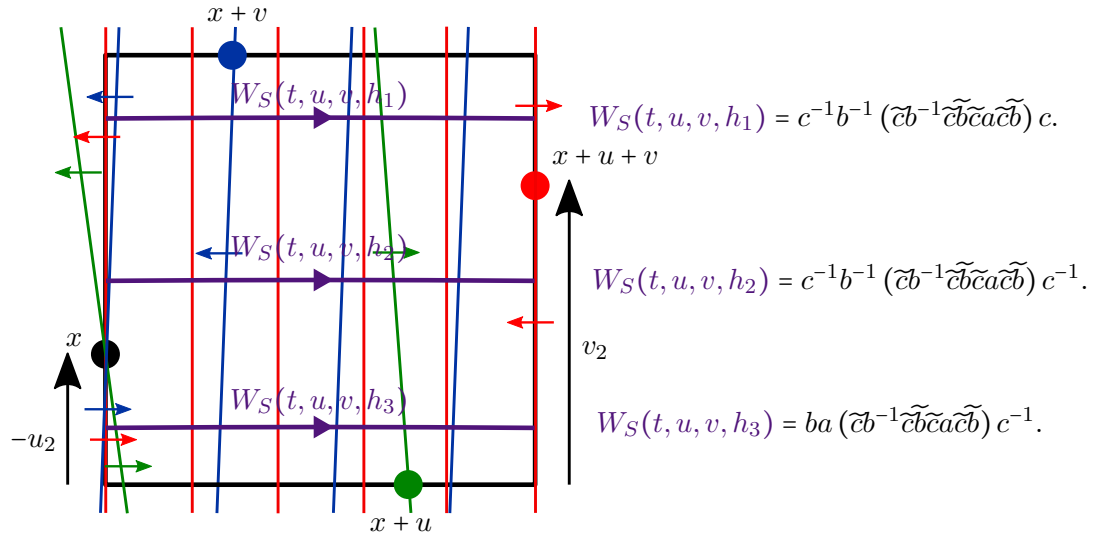

Figure 8.29: Proof of Lemma 8.19. Reading the subword  $W_S(t, u, v, h)$  in the square  $S(x, u, v)$ . Lines in  $L_A$  are in green, lines in  $L_B$  in blue and lines in  $L_C$  in red. We draw the case where  $x$  is of type  $abc$ ,  $x+u$  of type  $a$ ,  $x+v$  of type  $b$  and  $x+u+v$  of type  $c$ . Up to changing the two first letters and inverting the last one, the word  $W(t, u, v, h)$  does not depend on the height  $h$ .

In fact, our poof gives a more precise version of Lemma 8.19 by actually computing the first and last letters of  $W_S(u, v, h)$  depending on the type of  $t$  and  $\bar{t}$  (and of course on the height  $h$ ). We leave it here as a remark.

*Remark 8.20.* For all type  $t$  and for all  $0 < h < 1$ , there exists  $V_S(t, u, v)$  which does not depend on  $h$  such that :

1. If  $t = abc$  and  $\bar{t} = c$  (see figure 8.30a) :
  - If  $\max(-u_2, v_2) < h < 1$ , then  $W_S(t, u, v, h) = c^{-1}b^{-1}V_S(t, u, v)c$ .
  - If  $\min(-u_2, v_2) < h < \max(-u_2, v_2)$ , then  $W_S(t, u, v, h) = c^{-1}b^{-1}V_S(t, u, v)c^{-1}$ .

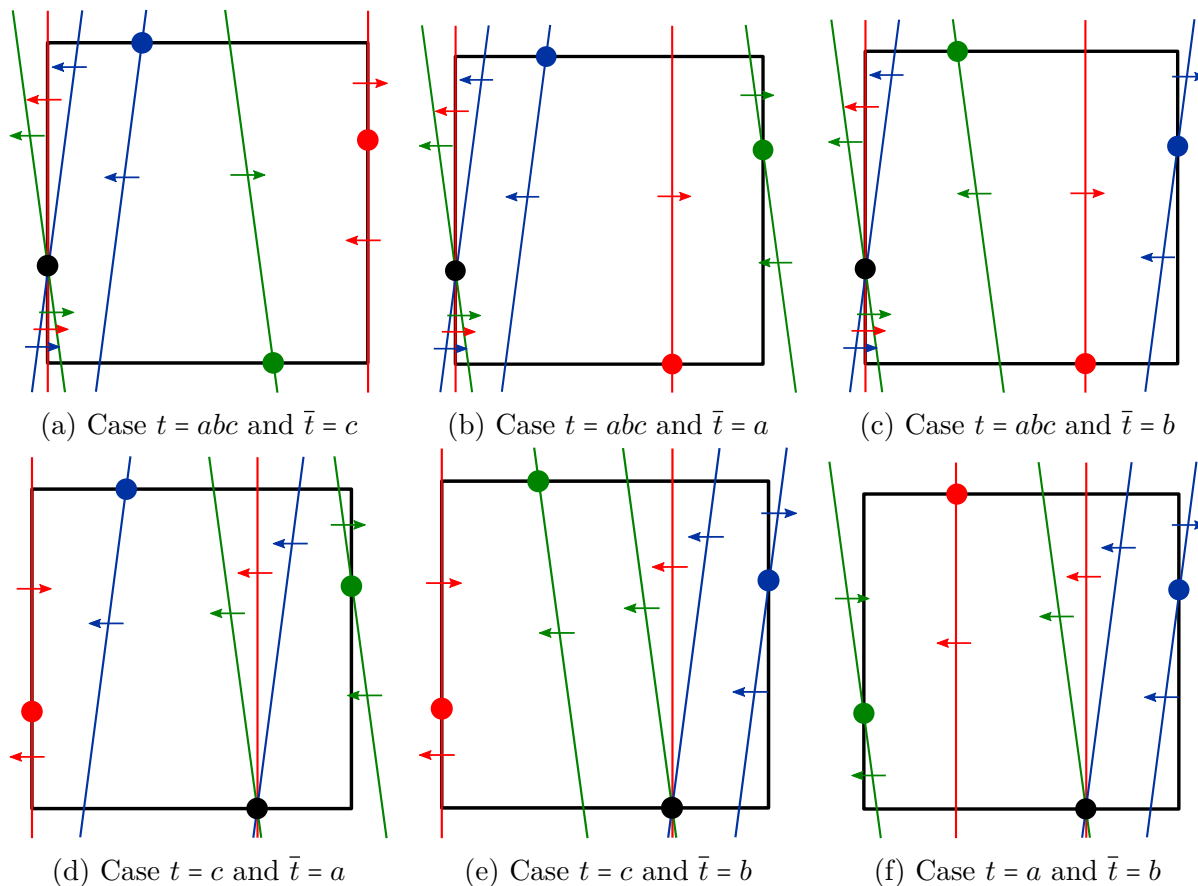

Figure 8.30: Reading  $W_S(t, u, v, h)$  in  $S(x, u, v)$  : the six cases of Remark 8.20. Only the lines passing through a point of  $\{x, x + u, x + v, x + u + v\}$  are represented on the pictures. The type of  $x$  is  $t$ , and the type of  $x + u + v$  is  $\bar{t}$ .

- If  $0 < h < \min(-u_2, v_2)$ , then  $W_S(t, u, v, h) = caV_S(t, u, v)c^{-1}$ .
2. If  $t = abc$  and  $\bar{t} = a$  (see figure 8.30b) :
    - If  $\max(-u_2, v_2) < h < 1$ , then  $W_S(t, u, v, h) = c^{-1}b^{-1}V_S(t, u, v)a$ .
    - If  $\min(-u_2, v_2) < h < \max(-u_2, v_2)$ , then  $W_S(t, u, v, h) = c^{-1}b^{-1}V_S(t, u, v)$ .
    - If  $0 < h < \min(-u_2, v_2)$ , then  $W_S(t, u, v, h) = caV_S(t, u, v)$ .
  3. If  $t = abc$  and  $\bar{t} = b$  (see figure 8.30c) :
    - If  $\max(-u_2, v_2) < h < 1$ , then  $W_S(t, u, v, h) = c^{-1}b^{-1}V_S(t, u, v)$ .
    - If  $\min(-u_2, v_2) < h < \max(-u_2, v_2)$ , then  $W_S(t, u, v, h) = c^{-1}b^{-1}V_S(t, u, v)b^{-1}$ .
    - If  $0 < h < \min(-u_2, v_2)$ , then  $W_S(t, u, v, h) = caV_S(t, u, v)b^{-1}$ .
  4. If  $t = c$  and  $\bar{t} = a$  (see figure 8.30d):

- If  $\max(-u_2, v_2) < h < 1$ , then  $W_S(t, u, v, h) = cV_S(t, u, v)a$ .
  - If  $\min(-u_2, v_2) < h < \max(-u_2, v_2)$ , then  $W_S(t, u, v, h) = cV_S(t, u, v)$ .
  - If  $0 < h < \min(-u_2, v_2)$ , then  $W_S(t, u, v, h) = c^{-1}V_S(t, u, v)$ .
5. If  $t = c$  and  $\bar{t} = b$  (see figure 8.30e):
- If  $\max(-u_2, v_2) < h < 1$ , then  $W_S(t, u, v, h) = cV_S(t, u, v)$ .
  - If  $\min(-u_2, v_2) < h < \max(-u_2, v_2)$ , then  $W_S(t, u, v, h) = cV_S(t, u, v)b^{-1}$ .
  - If  $0 < h < \min(-u_2, v_2)$ , then  $W_S(t, u, v, h) = c^{-1}V_S(t, u, v)b^{-1}$ .
6. If  $t = a$  and  $\bar{t} = b$  (see figure 8.30f):
- If  $\max(-u_2, v_2) < h < 1$ , then  $W_S(t, u, v, h) = V_S(t, u, v)$ .
  - If  $\min(-u_2, v_2) < h < \max(-u_2, v_2)$ , then  $W_S(t, u, v, h) = V_S(t, u, v)b^{-1}$ .
  - If  $0 < h < \min(-u_2, v_2)$ , then  $W_S(t, u, v, h) = a^{-1}V_S(t, u, v)b^{-1}$ .

*Remark 8.21.* Note that, using Lemma 8.18, we can deduce the six other cases (which are  $(t, \bar{t}) \in \{(c, abc), (a, abc), (b, abc), (a, c), (b, c), (b, a)\}$ ) by taking the inverses of the subwords found above.

Now we would like to write (a cyclic permutation of)  $\gamma$  (or its inverse) as a concatenation of words of the form  $W_S(x, u, v, h), W_R(x, u, v, h)$ . However, there is a small technical issue to fix here. Since the rectangles  $S(x, u, v)$  and  $S(x+u+v, u, v)$  intersect along one of their vertical sides (the right vertical side of  $S(x, u, v)$  and the left vertical side of  $S(x+u+v, u, v)$ ), the word read by following a horizontal line in  $S(x, u, v) \cup S(x+u+v, u, v)$  could not be the concatenation of  $W_S(x, u, v, h)$  then  $W_S(x+u+v, u, v, h')$  (for the corresponding heights  $h$  and  $h'$ ). In order to resolve this, let us consider  $I_S^*(x, u, v, h)$  (respectively  $I_R^*(x, u, v, h)$ ) the segment at height  $h$  in  $S_*(x, u, v)$  (respectively in  $R_*(x, u, v)$ ) and  $W_S^*(x, u, v, h)$  (resp.  $W_R^*(x, u, v, h)$ ) the word read by following  $I_S^*(x, u, v, h)$  (resp.  $I_R^*(x, u, v, h)$ ). Recall that  $S_*(x, u, v)$  and  $R_*(x, u, v)$  have been defined respectively in (8.2) and (8.4). Of course we also have that  $W_S^*(x, u, v, h)$  (resp.  $W_R^*(x, u, v, h)$ ) does not depend on the type of the point  $x$  and thus we write  $W_S^*(t, u, v, h)$  (resp.  $W_R^*(t, u, v, h)$ ) for  $t$  a type without ambiguity. Similarly, we consider  $*S(x, u, v)$  (resp.  $*R(x, u, v)$ ) the rectangle obtained by deleting the left vertical side of  $S(x, u, v)$  (resp.  $R(x, u, v)$ ) and we write  $*I_S(x, u, v, h)$  (resp.  $*I_R(x, u, v, h)$ ) for the segment at height  $h$  in  $*S(x, u, v)$  (resp.  $*R(x, u, v)$ ) and  $*W_S(x, u, v, h)$  (resp.  $*W_R(x, u, v, h)$ ) the word read by following  $*I_S(x, u, v, h)$  (resp.  $*I_R(x, u, v, h)$ ).

Now let us specify the lengths of subwords read in rectangles :

**Lemma 8.22.** *Let  $t$  be a type and  $0 < h < 1$  a height. We have the following inequalities :*

1.  $l'_i(\gamma) - 1 \leq \text{Length}(W_S^*(t, u, v, h)) \leq l'_i(\gamma) + 1$       and  
 $l'_i(\gamma) - 1 \leq \text{Length}(*W_S(t, u, v, h)) \leq l'_i(\gamma) + 1$
2.  $\text{Length}(W_R^*(t, u, v, h)) \leq l'_i(\gamma) + 1$       and  
 $\text{Length}(*W_R(t, u, v, h)) \leq l'_i(\gamma) + 1$

Denote

$$(u', v') = \begin{cases} (u, u+v) & \text{if } \text{Slope}(u+v) \geq 0 \\ (u+v, v) & \text{if } \text{Slope}(u+v) \leq 0 \end{cases}$$

$$3. \begin{aligned} l'_i(\gamma) + l_i(\gamma) - 1 &\leq \text{Length}(W_S^*(t, u', v', h)) \leq l'_i(\gamma) + l_i(\gamma) + 1 && \text{and} \\ l'_i(\gamma) + l_i(\gamma) - 1 &\leq \text{Length}(*W_S(t, u', v', h)) \leq l'_i(\gamma) + l_i(\gamma) + 1 \end{aligned}$$

$$4. \begin{aligned} \text{Length}(W_R^*(t, u', v', h)) &\leq l'_i(\gamma) + l_i(\gamma) + 1 && \text{and} \\ \text{Length}(*W_R(t, u', v', h)) &\leq l'_i(\gamma) + l_i(\gamma) + 1 \end{aligned}$$

*Proof.* 1. Let  $\max(-u_2, v_2) < h_1 < 1$ ,  $\min(-u_2, v_2) < h_2 < \max(-u_2, v_2)$  and  $0 < h_3 < \min(-u_2, v_2)$  be three heights. In order to simplify the notation, let us denote (see figure 8.31 on page 126):

$$\begin{aligned} W_j(t) &= W_S(t, u, v, h_j) & W_j(\bar{t}) &= W_S(\bar{t}, u, v, h_j) \\ W_j^*(t) &= W_S^*(t, u, v, h_j) & W_j(\bar{t}) &= W_S^*(\bar{t}, u, v, h_j) \\ *W_j(t) &= *W_S(t, u, v, h_j) & *W_j(\bar{t}) &= *W_S(\bar{t}, u, v, h_j) \end{aligned}$$

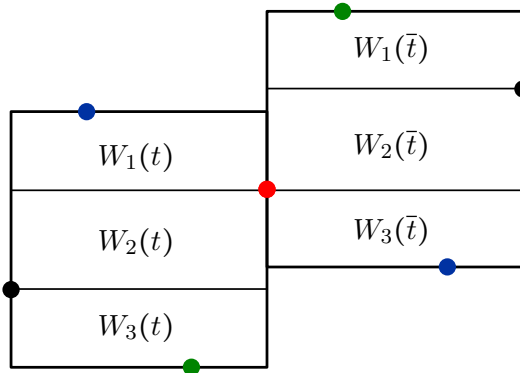

Figure 8.31: The six words  $W_1(t), W_2(t), W_3(t), W_1(\bar{t}), W_2(\bar{t}), W_3(\bar{t})$ .

We have, using the property on inverses of Lemma 8.18 :

$$\begin{aligned} W_1(t)^{-1} &= W_3(\bar{t}) & W_2(t)^{-1} &= W_2(\bar{t}) & W_3(t)^{-1} &= W_1(\bar{t}) \\ W_1^*(t)^{-1} &= *W_3(\bar{t}) & W_2^*(t)^{-1} &= *W_2(\bar{t}) & W_3^*(t)^{-1} &= *W_1(\bar{t}) \\ *W_1(t)^{-1} &= W_3^*(\bar{t}) & *W_2(t)^{-1} &= W_2^*(\bar{t}) & *W_3(t)^{-1} &= W_1^*(\bar{t}) \end{aligned} \quad (8.16)$$

The key point is that the word  $W_1^*(t)W_1^*(\bar{t})$  corresponds to a simple closed curve of slope  $\frac{p_i}{q_i} \oplus \frac{p_{i-1}}{q_{i-1}}$ , hence it is of length  $2l'_i(\gamma)$ .

$$\text{Length}(W_1^*(t)) + \text{Length}(W_1^*(\bar{t})) = 2l'_i(\gamma) \quad (8.17)$$

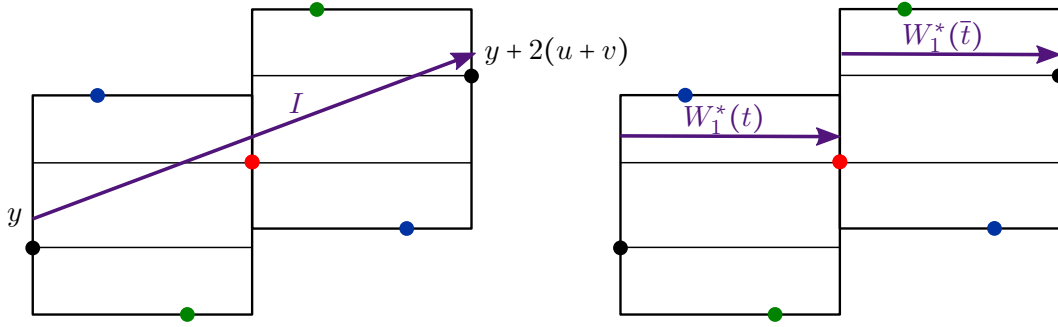

Figure 8.32: Reading the word of slope  $\frac{p_i}{q_i} \oplus \frac{p_{i-1}}{q_{i-1}}$

Indeed, consider as in the figure 8.32 on page 127 the segment  $I$  from  $y$  to  $y + 2(u + v)$ , where  $y$  is a point on the left vertical side of  $S(x, u, v)$ , with  $x$  of type  $t$ , and such that  $y_2 > x_2$ . Then in the quotient by  $(2\Lambda, \pm)$ , this segment is a simple closed curve of slope  $\text{Slope}(f_{\gamma, u, v}^{-1}(u)) \oplus \text{Slope}(f_{\gamma, u, v}^{-1}(v))$ . Moreover, by following the segment  $I$ , we read the word  $W_1^*(t)W_1^*(\bar{t})$ .

Let us now distinguish according the type  $(t, \bar{t})$  :

- If  $(t, \bar{t}) = (abc, c)$ , then we have, using remark 8.20 :

$$\begin{aligned} \text{Length}(W_1^*(t)) &= \text{Length}(W_2^*(t)) = \text{Length}(W_3^*(t)) \\ &= \text{Length}(*W_1(t)) = \text{Length}(*W_2(t)) = \text{Length}(*W_3(t)) \end{aligned}$$

from which we can deduce

$$\begin{aligned} \text{Length}(W_1^*(\bar{t})) &= \text{Length}(W_2^*(\bar{t})) = \text{Length}(W_3^*(\bar{t})) \\ &= \text{Length}(*W_1(\bar{t})) = \text{Length}(*W_2(\bar{t})) = \text{Length}(*W_3(\bar{t})) \end{aligned}$$

Therefore we can deduce :

$$\text{Length}(W_1^*(\bar{t})) = \text{Length}(*W_3(t)) = \text{Length}(*W_3(t)^{-1}) = \text{Length}(W_1^*(t))$$

so we can conclude, using (8.17) :

$$\text{Length}(W_1^*(t)) = \text{Length}(W_1^*(\bar{t})) = l'_i(\gamma)$$

and we also obtain :

$$\begin{aligned} \text{Length}(W_2^*(t)) &= \text{Length}(W_2^*(\bar{t})) = l'_i(\gamma) \\ \text{Length}(W_3^*(t)) &= \text{Length}(W_3^*(\bar{t})) = l'_i(\gamma). \end{aligned}$$

Finally, using (8.16) or noticing that this choice of  $t$  and  $\bar{t}$  implies  $*W_j(t) = W_j^*(t)$ , we also have :

$$\begin{aligned} \text{Length}(*W_1(t)) &= \text{Length}(*W_1(\bar{t})) = \text{Length}(*W_2(t)) = \text{Length}(*W_2(\bar{t})) \\ &= \text{Length}(*W_3(t)) = \text{Length}(*W_3(\bar{t})) = l_i(\gamma). \end{aligned} \tag{8.18}$$



- If  $(t, \bar{t}) \in \{(abc, a), (c, a)\}$ , then we have, using remark 8.20 :

$$\begin{aligned} \text{Length}(W_1^*(t)) &= \text{Length}(W_2^*(t)) + 1 = \text{Length}(W_3^*(t)) + 1 \\ &= \text{Length}(*W_1(t)) + 1 = \text{Length}(*W_2(t)) + 2 = \text{Length}(*W_3(t)) + 2 \end{aligned}$$

and

$$\begin{aligned} \text{Length}(W_1^*(\bar{t})) &= \text{Length}(W_2^*(\bar{t})) = \text{Length}(W_3^*(\bar{t})) - 1 \\ &= \text{Length}(*W_1(\bar{t})) - 1 = \text{Length}(*W_2(\bar{t})) - 1 = \text{Length}(*W_3(\bar{t})) - 2 \end{aligned}$$

Therefore we can deduce :

$$\text{Length}(W_1^*(t)) = \text{Length}(*W_3(t)) + 2 = \text{Length}(*W_3(t)^{-1}) + 2 = \text{Length}(W_1^*(\bar{t})) + 2$$

so we can conclude, using (8.17) :

$$\begin{aligned} \text{Length}(W_1^*(t)) &= l'_i(\gamma) + 1, & \text{Length}(W_1^*(\bar{t})) &= l'_i(\gamma) - 1, \\ \text{Length}(W_2^*(t)) &= l'_i(\gamma), & \text{Length}(W_2^*(\bar{t})) &= l'_i(\gamma) - 1, \\ \text{Length}(W_3^*(t)) &= l'_i(\gamma), & \text{Length}(W_3^*(\bar{t})) &= l'_i(\gamma). \end{aligned}$$

Finally, using (8.16) or noticing that this choice of  $t$  and  $\bar{t}$  implies  $*W_j(t) = W_j^*(t) - 1$  and  $*W_j(\bar{t}) = W_j^*(\bar{t}) + 1$ , we have :

$$\begin{aligned} \text{Length}(*W_1(t)) &= l'_i(\gamma), & \text{Length}(*W_1(\bar{t})) &= l'_i(\gamma), \\ \text{Length}(*W_2(t)) &= l'_i(\gamma) - 1, & \text{Length}(*W_2(\bar{t})) &= l'_i(\gamma), \\ \text{Length}(*W_3(t)) &= l'_i(\gamma) - 1, & \text{Length}(*W_3(\bar{t})) &= l'_i(\gamma) + 1. \end{aligned}$$

- If  $(t, \bar{t}) \in \{(abc, b), (c, b)\}$ , the proof is completely similar to the previous case. We obtain :

$$\begin{aligned} \text{Length}(W_1^*(t)) &= l'_i(\gamma), & \text{Length}(W_1^*(\bar{t})) &= l'_i(\gamma), \\ \text{Length}(W_2^*(t)) &= l'_i(\gamma) + 1, & \text{Length}(W_2^*(\bar{t})) &= l'_i(\gamma), \\ \text{Length}(W_3^*(t)) &= l'_i(\gamma) + 1, & \text{Length}(W_3^*(\bar{t})) &= l'_i(\gamma) - 1. \end{aligned}$$

Finally, using (8.16) or noticing that this choice of  $t$  and  $\bar{t}$  implies  $*W_j(t) = W_j^*(t) - 1$  and  $*W_j(\bar{t}) = W_j^*(\bar{t}) + 1$ , we have :

$$\begin{aligned} \text{Length}(*W_1(t)) &= l'_i(\gamma) - 1, & \text{Length}(*W_1(\bar{t})) &= l'_i(\gamma) + 1, \\ \text{Length}(*W_2(t)) &= l'_i(\gamma), & \text{Length}(*W_2(\bar{t})) &= l'_i(\gamma) + 1, \\ \text{Length}(*W_3(t)) &= l'_i(\gamma), & \text{Length}(*W_3(\bar{t})) &= l'_i(\gamma). \end{aligned}$$

- If  $(t, \bar{t}) \in (a, b)$ , the proof is again similar to the previous cases. We obtain :

$$\begin{aligned} \text{Length}(W_1^*(t)) &= l'_i(\gamma) - 1, & \text{Length}(W_1^*(\bar{t})) &= l'_i(\gamma) + 1, \\ \text{Length}(W_2^*(t)) &= l'_i(\gamma), & \text{Length}(W_2^*(\bar{t})) &= l'_i(\gamma), \\ \text{Length}(W_3^*(t)) &= l'_i(\gamma) + 1, & \text{Length}(W_3^*(\bar{t})) &= l'_i(\gamma) - 1. \end{aligned}$$

Finally, using (8.16) or noticing that this choice of  $t$  and  $\bar{t}$  implies  ${}^*W_j(t) = W_j^*(t)$ , we have :

$$\begin{aligned} \text{Length}({}^*W_1(t)) &= l'_i(\gamma) - 1, & \text{Length}({}^*W_1(\bar{t})) &= l'_i(\gamma) + 1, \\ \text{Length}({}^*W_2(t)) &= l'_i(\gamma), & \text{Length}({}^*W_2(\bar{t})) &= l'_i(\gamma), \\ \text{Length}({}^*W_3(t)) &= l'_i(\gamma) + 1, & \text{Length}({}^*W_3(\bar{t})) &= l'_i(\gamma) - 1. \end{aligned}$$

Note that we have covered all the possible cases, and thus for all heights  $h$  and all types  $t$ , we have  $l'_i(\gamma) - 1 \leq \text{Length}(W_S^*(t, u, v, h)) \leq l'_i(\gamma) + 1$  and  $l'_i(\gamma) - 1 \leq \text{Length}({}^*W_S(t, u, v, h)) \leq l'_i(\gamma) + 1$ .

2. We use the fact that  $R(x, u, v) \subset \begin{cases} S(x - v, u, v) & \text{if Slope}(u + v) \geq 0 \\ S(x - u, u, v) & \text{if Slope}(u + v) \leq 0 \end{cases}$ .

Then  $W_R^*(x, u, v, h)$  is a subword of  $W_S^*(x - v, u, v, h')$  or  $W_S^*(x - u, u, v, h')$  for some height  $h'$ . But by the previous point  $\text{Length}(W_S^*(x - v, u, v, h')) \leq l'_i(\gamma) + 1$  and  $\text{Length}(W_S^*(x - u, u, v, h')) \leq l'_i(\gamma) + 1$ , (for all  $h'$ ). Hence the second inequality.

3. The proof is the same as above, working this time in the rectangle  $S(x, u', v') = S'(x, u, v)$  and using the fact that the slope of  $f_{\gamma, u, v}^{-1}(u') + f_{\gamma, u, v}^{-1}(v')$  is  $\frac{p_i}{q_i} \oplus 2\frac{p_{i-1}}{q_{i-1}}$  (and  $l'_i(\gamma) + l_i(\gamma) = p_i + q_i + 2p_{i-1} + 2q_{i-1}$ ).
4. Same as above, using the previous point.

□

At last, we end this section by giving a decomposition of  $\gamma$ , or more generally of any subword of  $\gamma$ , as a concatenation of words read in  $S(x, u, v)$  and  $R(x, u, v)$ .

**Lemma 8.23.** *Let  $t \in \Lambda/2\Lambda$  be a type and  $\bar{t}$  its  $(u, v)$ -opposite type. Let  $W$  be a subword of (a cyclic-permutation of)  $\gamma$  or its inverse.*

*There exists an integer  $p \in \mathbb{N}$  such that for all  $0 \leq j \leq p + 1$ , there exists a real  $0 < h_j < 1$  and a type  $t_j \in \{t, \bar{t}\}$  such that we have the following decomposition of  $W$  :*

$$W = \mathbf{s}(W_0)W_1 \cdots W_p \mathbf{p}(W_{p+1})$$

*with, for all  $0 \leq j \leq p + 1$ , either  $W_j = W_S^*(t_j, u, v, h_j)$  or  $W_j = W_R^*(t_j, u, v, h_j)$ , and  $\mathbf{s}(W_0)$  is a suffix of  $W_0$ ,  $\mathbf{p}(W_{p+1})$  is a prefix of  $W_{p+1}$ . Moreover :*

1. *If  $W_j = W_R^*(t_j, u, v, h_j)$ , then  $W_{j+1} = W_S^*(t_{j+1}, u, v, h_{j+1})$ .*

2. The types  $t_j$  are alternating. Precisely : if  $t_0 = t$ , then  $t_j = \begin{cases} t & \text{if } j \text{ is even} \\ \bar{t} & \text{if } j \text{ is odd} \end{cases}$ ,

and if  $t_0 = \bar{t}$ , then  $t_j = \begin{cases} \bar{t} & \text{if } j \text{ is even} \\ t & \text{if } j \text{ is odd} \end{cases}$ .

*Proof.* There exists a horizontal segment  $I$  in  $\mathbb{R}^2$  such that the word we read following  $I$  is  $W$ . Now the proof is direct by applying Lemma 8.13 to  $I$ . Since the segments  $I_j$  of this lemma can only intersect in a point, we deduce that  $W$  is the concatenation of the words  $W_j$ , where  $W_j$  is the word read by following  $I_j$ , that is  $W_S^*(t_j, u, v, h_j)$  or  $W_R^*(t_j, u, v, h_j)$ .

- The first point of Lemma 8.23 comes from the third point of Lemma 8.13.
- The second point of Lemma 8.23 comes from the second point of Corollary 8.14.

□

### 8.6.4 Proof of Proposition 8.16 (magic-lengths)

*Proof of Proposition 8.16.*

First note that without loss of generality, we can assume that  $W$  is a subword of a cyclic-permutation of  $\gamma$  : indeed, if it is a subword of a cyclic-permutation of  $\gamma^{-1}$ , just take the inverse of the concatenation obtained for  $W^{-1}$  (which is a subword of a cyclic-permutation of  $\gamma$ ). We can also assume that  $w$  is a subword of a cyclic-permutation of  $\gamma$  : indeed, if  $w$  is a subword of a cyclic-permutation of  $\gamma^{-1}$ ,  $w^{-1}$  is a subword of a cyclic-permutation of  $\gamma$  of the same length, and thus the same decomposition for  $W$  holds.

Also remark that if  $i = 0$ , then  $l_i(\gamma) = 1 < 10$  and if  $i = 1$  and  $n_1 = 0$ , then  $l_i(\gamma) = 1 < 10$ . Moreover, if  $i = r(\gamma)$ , then we have  $|W| \geq 3(l'_i(\gamma) + l_{r(\gamma)}(\gamma) + 1) > 2l_{r(\gamma)}(\gamma) = |\gamma|$  and this is impossible since  $W$  is supposed to be a subword of (a cyclic-permutation of)  $\gamma$  (or its inverse).

Therefore let us fix  $1 \leq i < r(\gamma)$ , such that if  $i = 1$ , then  $n_1 \neq 0$ , and assume that  $l_i(\gamma) \geq 10$ .

Fix  $W$  a subword of (a cyclic permutation of)  $\gamma$  (or its inverse) of length  $|W| \geq 3(l'_i(\gamma) + l_i(\gamma) + 1)$  and  $w$  a subword of (a cyclic permutation of)  $\gamma$  (or its inverse) of length  $|w| = l_i(\gamma) - 5$ .

Now that the integer  $i$  is fixed, we can consider the map  $f_{\gamma, u, v}$  as well as the lattice  $\Lambda$  and its basis  $(u, v)$  which have been defined in section 8.6.1 (note that as in this section, we still denote by  $(u, v)$  the image of the basis of  $\mathbb{Z}^2$  after applying the map  $f_{\gamma, u, v}$ ). Recall that with our definition, we automatically have that  $\text{Slope}(u + v)$  and  $\text{Slope}(v - u)$  are of opposite signs.

Consider  $w'$  the subword of  $\gamma$  obtained from  $w$  by adding two letters on the left and two letters on the right. Thus, we can write  $w' = pws$ , such that  $pws$  is reduced,  $|p| = 2, |s| = 2$ , and  $w'$  is a subword of (a cyclic-permutation of)  $\gamma$  or its inverse of length  $|w'| = l_i(\gamma) - 1$ . By Lemma 8.17, there exists a horizontal segment  $I_{w'}$  such that we read  $w'$  by following  $I_{w'}$ , and such that, denoting  $l(I_{w'})$  the length of  $I_{w'}$ , we have :  $l(I_{w'})l'_i(\gamma) \leq |w'| + 1$ . So  $l(I_{w'}) \leq \frac{l_i(\gamma)}{l'_i(\gamma)}$ . Then we can consider a

horizontal segment  $I$  of length  $\frac{l_i(\gamma)}{l'_i(\gamma)}$  containing  $I_{w'} \subset I$ . But recall, by the computation (8.13), that  $\max(u_1, v_1) = \frac{l_i(\gamma)}{l'_i(\gamma)}$ . Therefore, we can apply Lemma 8.12 and find a point  $x \in \Lambda$  such that :

1. Either  $I \subset S_*(x, u, v)$
2. Or  $I \subset T_*(x, u, v)$ .

(Recall that  $S_*(x, u, v)$  and  $T_*(x, u, v)$  have been defined respectively in (8.2) and (8.6)).

We treat the two cases separately.

1. Suppose that  $I \subset S_*(x, u, v)$ .

We use Lemma 8.23 to ensure that we can write  $W$  in the following way :

$$W = \mathbf{s}(W_0)W_1 \cdots W_p \mathbf{p}(W_{p+1}) \quad (8.19)$$

with, for all  $0 \leq j \leq p+1$ , either  $W_j = W_S^*(t_j, u, v, h_j)$  or  $W_j = W_R^*(t_j, u, v, h_j)$ , and  $t_j$  and  $h_j$  as defined in the Lemma. Recall that  $\mathbf{s}(W_0)$  and  $\mathbf{p}(W_{p+1})$  denote respectively a suffix of  $W_0$  and a prefix of  $W_{p+1}$ . Set  $\mathcal{J} = \{j \in \{1, \dots, p\} \mid W_j = W_S^*(t, u, v, h_j)\}$ ,  $\overline{\mathcal{J}} = \{j \in \{1, \dots, p\} \mid W_j = W_S^*(\bar{t}, u, v, h_j)\}$  and  $\mathcal{K} = \{j \in \{1, \dots, p\} \mid W_j = W_R^*(t_j, u, v, h_j)\}$ . Of course we have  $\{1, \dots, p\} = \mathcal{J} \sqcup \overline{\mathcal{J}} \sqcup \mathcal{K}$ .

- (a) Let us show that  $w$  is a subword of  $W_j$ , for all  $j \in \mathcal{J}$ , and that  $w^{-1}$  is a subword of  $W_j$ , for all  $j \in \overline{\mathcal{J}}$  :

Recall that by construction of the horizontal segment  $I$ , we have  $I_{w'} \subset I$ , so by our hypothesis  $I \subset S_*(x, u, v)$ , we also have  $I_{w'} \subset S_*(x, u, v)$ . Then we deduce that  $w'$  is a subword of  $W_S^*(t, u, v, h)$ , for a well chosen  $0 < h < 1$  and  $t$  the type of  $x$ . In addition, Lemma 8.19 ensures that for all  $j \in \mathcal{J}$ ,  $W_j$  and  $W_S(t, u, v, h)$  are equal up to adding or deleting a letter at the beginning or at the end of  $W_j$ , and up to changing its first two or last two letters. Then the subword  $w'$ , up to the previous changes, is always a subword of  $W_j$ , for  $j \in \mathcal{J}$ . But these changes affect at most the first two letters of  $w'$  and the last two letters of  $w'$  (in fact, never all four at the same time but this detail doesn't matter here), and since  $w' = pws$ , with  $|p| = |s| = 2$  (this decomposition is cyclically reduced), we deduce that these changes can only affect  $p$  and  $s$ . Therefore, we can conclude that  $w$  is a subword of  $W_j$ , for all  $j \in \mathcal{J}$ .

A similar argument applies for  $w^{-1}$ . Since  $w'$  is a subword of  $W_S^*(t, u, v, h)$ , we deduce by Lemma 8.18 that  $w'^{-1}$  is a subword of  $W_S(\bar{t}, u, v, 1-h)$ . Thus, as before, using Lemma 8.19, we deduce that for all  $j \in \overline{\mathcal{J}}$ ,  $W_j$  and  $W_S(\bar{t}, u, v, 1-h)$  are equal up to some changes of letters affecting at most the first two letters and the last two letters. Since  $w'^{-1} = s^{-1}w^{-1}p^{-1}$ , with  $|s^{-1}| = |p^{-1}| = 2$ , we deduce that  $w^{-1}$  is itself a subword of  $W_j$ , for all  $j \in \overline{\mathcal{J}}$ .

(b) Decomposition of  $W$  and proof of point 1 of Proposition 8.16 :

Let  $q = \#\mathcal{J} + \#\overline{\mathcal{J}}$ . By letting  $u_2, u_4, \dots, u_{2q}$  be the occurrences of  $w$  and  $w^{-1}$  in  $W_j$ , for  $j \in \mathcal{J} \cup \overline{\mathcal{J}}$ , guaranteed by the previous point, we deduce that  $u_2, u_4, \dots, u_{2q}$  are pairwise disjoint. Also let  $u_1, u_3, \dots, u_{2q+1}$  be the remainders in between in the word  $W$ , then we can write :

$$W = u_1 u_2 \cdots u_{2q+1} \quad (8.20)$$

Moreover, by construction, for all  $k \in 2\{1, \dots, q\}$ ,  $u_k$  is either equal to  $w$  or equal to  $w^{-1}$ . Thus point 1 of Proposition 8.16 is proved, setting  $\mathcal{I} = 2\{1, \dots, q\}$ .

(c) Let us show that  $\max(\#\mathcal{J}, \#\overline{\mathcal{J}}) \geq 1$  :

By contradiction, if  $\#\mathcal{J} = \#\overline{\mathcal{J}} = 0$ , then, since a subword of the form  $W_R^*(t_i, u, v, h_i)$  is necessarily followed by a word of the form  $W_S^*(t_{i+1}, u, v, h_{i+1})$ , we must have  $\#\mathcal{K} \leq 1$  and then  $p \leq 1$ . Therefore  $|W| \leq |\mathbf{s}(W_0)| + |W_1| + |\mathbf{p}(W_{p+1})|$ . But we also know, by Lemma 8.22, that for all  $0 \leq j \leq p+1$ ,  $|W_j| \leq l'_i(\gamma) + 1$ . Then we deduce :

$$|W| \leq 3(l'_i(\gamma) + 1) < 3(l'_i(\gamma) + l_i(\gamma) + 1) \quad (8.21)$$

and this contradicts our hypothesis on the length of  $W$ . In particular, we proved :

$$\#\mathcal{J} + \#\overline{\mathcal{J}} \geq 1 \quad (8.22)$$

(d) Proof of point 2 of Proposition 8.16 :

On one hand we have :

$$\sum_{k \in \mathcal{I}} |u_k| = \sum_{k \in \mathcal{I}} |w| = \#\mathcal{I}|w| = q|w| = (\#\mathcal{J} + \#\overline{\mathcal{J}})(l_i(\gamma) - 5) \geq (\#\mathcal{J} + \#\overline{\mathcal{J}}) \frac{1}{2} l_i(\gamma) \quad (8.23)$$

and the last inequality holds because  $l_i(\gamma) \geq 10$ .

On the other hand, using (8.19), we have :

$$|W| = |\mathbf{p}(W_0)| + |\mathbf{s}(W_{p+1})| + \sum_{j \in \mathcal{J}} |W_j| + \sum_{j \in \overline{\mathcal{J}}} |W_j| + \sum_{j \in \mathcal{K}} |W_j|.$$

In addition, we know, by Lemma 8.22, that for all  $0 \leq j \leq p+1$  :  $|W_j| \leq l'_i(\gamma) + 1$ . Then we deduce :

$$\begin{aligned} |W| &\leq 2(l'_i(\gamma) + 1) + (\#\mathcal{J} + \#\overline{\mathcal{J}} + \#\mathcal{K})(l'_i(\gamma) + 1) \\ &\leq 4l_i(\gamma) + 2(\#\mathcal{J} + \#\overline{\mathcal{J}} + \#\mathcal{K})l_i(\gamma) \quad \text{using } l'_i(\gamma) + 1 \leq 2l_i(\gamma) \end{aligned}$$

Moreover, recall that a subword of the form  $W_R^*(t_i, u, v, h_i)$  is necessarily followed by a subword of the form  $W_S^*(t_{i+1}, u, v, h_{i+1})$ , then if  $j \in \mathcal{K} \cap \{1, \dots, p-1\}$ , then  $j+1 \notin \mathcal{K}$  and so we deduce that  $\#\mathcal{K} \leq \#\mathcal{J} + \#\overline{\mathcal{J}} + 1$ . Therefore :

$$\begin{aligned} |W| &\leq 4l_i(\gamma) + 2(2(\#\mathcal{J} + \#\overline{\mathcal{J}}) + 1)l_i(\gamma) = 4(\#\mathcal{J} + \#\overline{\mathcal{J}})l_i(\gamma) + 6l_i(\gamma) \\ &\leq 10(\#\mathcal{J} + \#\overline{\mathcal{J}})l_i(\gamma) \quad \text{by (8.22)} \\ &\leq 20 \sum_{k \in \mathcal{I}} |u_k| \quad \text{by (8.23)} \end{aligned} \tag{8.24}$$

This last inequality finishes the proof of point 2 of Proposition 8.16 in the case where  $I \subset S_*(x, u, v)$ .

2. Suppose that  $I \subset T_*(x, u, v)$ . In particular, since  $T_*(x, u, v) \subset S'_*(x, u, v)$  (see (8.8)), we have  $I \subset S'_*(x, u, v)$ . Let us denote :

$$(u', v') = \begin{cases} (u, u+v) & \text{if } \text{Slope}(u+v) \geq 0 \\ (u+v, v) & \text{if } \text{Slope}(u+v) \leq 0 \end{cases}$$

Then we have  $S'_*(x, u, v) = S_*(x, u', v')$  and  $S'^{\pm}(x, u, v) = S^{\pm}(x, u', v')$ .

Recall that inequality (8.14) ensures that :  $\text{Slope}(u+v) \neq 0$ . Then we have :

$$\text{Slope}(u') < 0 < \text{Slope}(v').$$

We now distinguish according to the signs of  $\text{Slope}(u'+v')$  and  $\text{Slope}(v'-u')$ .

- Suppose that  $\text{Slope}(u'+v')$  and  $\text{Slope}(v'-u')$  are of opposite signs. We will then proceed in exactly the same way as in the first case, changing  $(u, v)$  to  $(u', v')$ . The proof is then completely unchanged, except that we no longer have the inequality  $|W_j| \leq l'_i(\gamma) + 1$ , but instead  $|W_j| \leq l'_i(\gamma) + l_i(\gamma) + 1$  (see point 3 and 4 in Lemma 8.22). The inequalities change as follow :

- (c) Let us show that  $\max(\#\mathcal{J}, \#\overline{\mathcal{J}}) \geq 1$  :

Suppose that  $\#\mathcal{J} = \#\overline{\mathcal{J}} = 0$ , then, similarly to (8.21), we can bound  $|W|$  :

$$|W| \leq 3(l'_i(\gamma) + l_i(\gamma) + 1)$$

and this is a contradiction with our hypothesis on the length of  $W$ .

- (d) Proof of point 2 of Proposition 8.16 :

Equation (8.23) doesn't change :

$$\sum_{k \in \mathcal{I}} |u_k| \geq (\#\mathcal{J} + \#\overline{\mathcal{J}}) \frac{1}{2} l_i(\gamma). \tag{8.25}$$

Then, similarly to computation (8.24), we can bound  $|W|$  :

$$\begin{aligned}
|W| &\leq 2(l'_i(\gamma) + l_i(\gamma) + 1) + (\#\mathcal{J} + \#\overline{\mathcal{J}} + \#\mathcal{K})(l'_i(\gamma) + l_i(\gamma) + 1) \\
&\leq 6l_i(\gamma) + 3(\#\mathcal{J} + \#\overline{\mathcal{J}} + \#\mathcal{K})l_i(\gamma) \quad \text{using } l'_i(\gamma) + l_i(\gamma) + 1 \leq 3l_i(\gamma) \\
&\leq 6(\#\mathcal{J} + \#\overline{\mathcal{J}})l_i(\gamma) + 9l_i(\gamma) \quad \text{since } \#\mathcal{K} \leq \#\mathcal{J} + \#\overline{\mathcal{J}} + 1 \\
&\leq 15(\#\mathcal{J} + \#\overline{\mathcal{J}})l_i(\gamma) \quad \text{because } \#\mathcal{J} + \#\overline{\mathcal{J}} \geq 1 \\
&\leq 30 \sum_{k \in \mathcal{I}} |u_k| \quad \text{by (8.25)}
\end{aligned}$$

- Suppose now that  $\text{Slope}(u' + v')$  and  $\text{Slope}(v' - u')$  are of the same sign. Notice that our choice of  $u, v$  and  $u', v'$  imposes that  $\text{Slope}(u', v') \neq 0$  and  $\text{Slope}(v' - u') \neq \infty$ , we deduce in particular that  $S'(x, u, v) \setminus T(x, u, v)$  has non-empty interior.

We are going to do almost the same procedure as in the previous cases, but we need to be a little more careful since the rectangles  $S(y, u', v')$  for different  $y$  intersect, hence the occurrences of  $w$  might not be disjoint. Denote by  $t$  the type of  $x$  and  $\bar{t}$  its  $(u', v')$ -opposite type.

Let  $I_W$  be an horizontal segment such that we read  $W$  by following  $I_W$ . By Lemma 8.15, there exist  $x_0, \dots, x_{p+1} \in \Lambda$  and  $h_0, \dots, h_{p+1}$  some heights such that we can write  $I_W$  as a union of segments :

$$I_W = I_0 \cup I_1 \cup \dots \cup I_p \cup I_{p+1} \quad (8.26)$$

satisfying :

- $I_0 \subset I_S(x_0, u', v', h_0), I_{p+1} \subset I_S(x_{p+1}, u', v', h_{p+1})$
- For all  $1 \leq j \leq p$ ,  $I_j = I_S(x_j, u', v', h_j)$
- For all  $0 \leq j \leq p+1$ ,  $x_j$  is of type  $t$  or  $\bar{t}$
- $\inf I_j < \inf I_k$  when  $j < k$  (this is a consequence of the third point of Lemma 8.15)

For all  $j \in \{0, \dots, p+1\}$ , let us denote  $W_j$  the subword read by following  $I_j$ . Therefore for all  $1 \leq j \leq p$ ,  $W_j = W_S(x_j, u', v', h_j)$  and  $W_0$  and  $W_{p+1}$  are subwords respectively of  $W_S(x_0, u', v', h_0)$  and  $W_S(x_{p+1}, u', v', h_{p+1})$ . Notice that the intervals  $I_j$  for  $0 \leq j \leq p+1$  might have non-empty intersection, hence the subwords  $W_j$  are not necessarily disjoint in  $W$ . Set  $\mathcal{J} = \{j \in \{1, \dots, p\} \mid W_j = W_S(t, u', v', h_j)\}$ ,  $\overline{\mathcal{J}} = \{j \in \{1, \dots, p\} \mid W_j = W_S(\bar{t}, u', v', h_j)\}$ . Of course we have  $\{1, \dots, p\} = \mathcal{J} \sqcup \overline{\mathcal{J}}$ . Also denote  $W_j^*$  the subword read by following  $I_S^*(x_j, u', v', h_j)$ .

- (a) Let us show that  $w$  is a subword of  $W_j$  for all  $j \in \mathcal{J}$  and that  $w^{-1}$  is a subword of  $W_j$  for all  $j \in \overline{\mathcal{J}}$  :

The proof is the same as in the first case 1a changing the basis  $(u, v)$  to  $(u', v')$ . We recall here the main steps : we have  $I_{w'} \subset I \subset S'_*(x, u, v) = S_*(x, u', v')$ , so  $w'$  is a subword of  $W_S^*(t, u', v', h)$ , for some well chosen  $0 < h < 1$ . In addition, Lemma 8.19 ensures that for all  $j \in \mathcal{J}$ ,  $W_j$  and  $W_S(t, u', v', h)$  are equal up to some change of letters which affect at most the first two letters of  $w'$  and the last two letters of  $w'$ . Since  $w' = pws$ , with  $|p| = |s| = 2$ , we deduce that  $w$  is a subword of  $W_j$ , for all  $j \in \mathcal{J}$ .

By noticing, using Lemma 8.18, that  $w'^{-1}$  is a subword of  $W_S(\bar{t}, u', v', h')$ , for some well chosen  $h'$ , we deduce in the same way that  $w^{-1}$  is a subword of  $W_j$ , for all  $j \in \overline{\mathcal{J}}$ .

(b) Decomposition of  $W$  and proof of point 1 of Proposition 8.16 :

Let  $q = \#\mathcal{J} + \#\overline{\mathcal{J}}$  and  $u_2, u_4, \dots, u_{2q}$  be the occurrences of  $w$  and  $w^{-1}$  in  $W_j$ , for  $j \in \mathcal{J} \cup \overline{\mathcal{J}} = \{1, \dots, p\}$ , guaranteed by the previous point. The key point is to justify that the subwords  $u_2, u_4, \dots, u_{2q}$  are disjoint in  $W$ . For  $j \in \{1, \dots, p\}$ , let  $I_{u_{2j}} \subset I_j$  be a horizontal segment such that the subword read by following  $I_{u_{2j}}$  is  $u_{2j}$ . Then, since  $I_{w'} \subset I \subset T_*(x, u, v)$  by hypothesis, we deduce that  $I_{u_{2j}} \subset T_*(x_j, u, v)$ . But recall that by Lemma 8.11, all the rectangles  $T_*(x_j, u, v)$  for  $j \in \mathcal{J} \cup \overline{\mathcal{J}}$  are disjoint. Therefore we deduce that the segments  $I_{u_{2j}}$  for  $j \in \{1, \dots, p\}$  are disjoint, then so are the subwords  $u_{2j}$  in  $W$ . Now the rest of the proof follows as in 1b : let  $u_1, u_3, \dots, u_{2q+1}$  be the remainders in between in the word  $W$ , so we can write :

$$W = u_1 u_2 \dots u_{2q+1} \quad (8.27)$$

and by construction, for all  $k \in 2\{1, \dots, q\}$ ,  $u_k$  is either equal to  $w$  or to  $w^{-1}$ . Thus point 1 of Proposition 8.16 is proved, setting  $\mathcal{I} = 2\{1, \dots, q\}$ .

(c) Let us show that  $p \geq 1$  :

By contradiction, if  $p = 0$ , then

$$\begin{aligned} |W| &\leq |W_0^*| + |W_1^*| \leq 2(l'_i(\gamma) + l_i(\gamma) + 1) \text{ using Lemma 8.22} \\ &< 3(l'_i(\gamma) + l_i(\gamma) + 1) \end{aligned}$$

which is a contradiction with our hypothesis on the length of  $W$ .

(d) Proof of point 2 of Proposition 8.16 :

On the one hand we have :

$$\sum_{k \in \mathcal{I}} |u_k| = \sum_{k \in \mathcal{I}} |w| = p(l_i \gamma - 5) \geq \frac{p}{2} l_i(\gamma) \quad (8.28)$$

and the last inequality holds because  $l_i(\gamma) \geq 10$ .

On the other hand, using the equality (8.26), we have :

$$\begin{aligned} |W| &\leq |W_0^*| + |W_{p+1}^*| + \sum_{j=1}^p |W_j^*| \leq (p+2)(l'_i(\gamma) + l_i(\gamma) + 1) \text{ by point 3 in Lemma 8.22} \\ &\leq 3(p+2)l_i(\gamma) \quad \text{since } l'_i(\gamma) + 1 \leq l_i(\gamma) \\ &\leq 9pl_i(\gamma) \quad \text{using } p \geq 1 \\ &\leq 18 \sum_{k \in \mathcal{I}} |u_k| \quad \text{by (8.28).} \end{aligned}$$



This last inequality finishes the proof of point 2 of Proposition 8.16 in the case where  $I \subset T_*(x, u, v)$ .

□

# Chapter 9

## Local uniform quasi-geodesicity

### 9.1 A first example of a uniform quasi-geodesicity setting

Let  $(X, d)$  be a  $\delta$ -hyperbolic space, geodesic and proper.

Fix  $G, D_1$  and  $D_2$  three isometries of  $X$ . We can consider the set  $\mathcal{W}(G, D_1, D_2)$  of (finite) words on the alphabet  $\mathcal{A} = \{G, G^{-1}, D_1, D_1^{-1}, D_2, D_2^{-1}\}$ . For  $W \in \mathcal{W}(G, D_1, D_2)$ , we denote by  $|W|$  its word length ( $W$  is seen as a word on the alphabet  $\mathcal{A}$ ). We also consider  $\mathcal{H}(G, D_1, D_2)$  the set of bi-infinite (reduced) words on the alphabet  $\mathcal{A}$ , that is,  $H = (H_n)_{n \in \mathbb{Z}} \in \mathcal{H}(G, D_1, D_2)$  if and only if for all  $n \in \mathbb{Z}$ ,  $H_n \in \mathcal{A}$  and  $H_n \neq H_{n+1}^{-1}$ . When we have a bi-infinite word  $H = (H_n) \in \mathcal{H}(G, D_1, D_2)$ , we associate to it a bi-infinite sequence of finite words  $W = (W_n)_{n \in \mathbb{Z}}$  in the following way :

$$W_n = \begin{cases} H_0 H_1 \cdots H_{n-1} & \text{for } n > 0 \\ I_d & \text{for } n = 0 \\ H_{-1}^{-1} \cdots H_n^{-1} & \text{for } n < 0 \end{cases}$$

Hence  $W_n \in \mathcal{W}(G, D_1, D_2)$  for all  $n \in \mathbb{Z}$ . Moreover, the word length of  $W_n$  is  $|W_n| = |n|$  for all  $n \in \mathbb{Z}$  and the following recursive formula holds for all  $n \in \mathbb{Z}$  :  $W_{n+1} = W_n H_n$ . We denote by  $\mathcal{G}(G, D_1, D_2)$  the set of bi-infinite sequences of finite words associate to bi-infinite words in  $\mathcal{H}(G, D_1, D_2)$ .

In this section, we want to study a particular class of bi-infinite words  $H = (H_n)_{n \in \mathbb{Z}}$  and their associate bi-infinite sequences of words  $W = (W_n)_{n \in \mathbb{Z}}$ . Let us fix an integer  $N \geq 1$  and define  $\mathcal{H}_N(G, D_1, D_2)$  to be the subset of  $\mathcal{H}(G, D_1, D_2)$  consisting of the bi-infinite words  $H = (H_n)_{n \in \mathbb{Z}}$  which satisfy the following condition :

If  $n_1 < n_2$  are two integers in  $\mathbb{Z}$  such that  $H_{n_1}, H_{n_2} \in \{D_1, D_1^{-1}, D_2, D_2^{-1}\}$  and for all  $n_1 < n < n_2$ ,  $H_n \in \{G^{\pm 1}\}$ , then :

- If  $H_{n_1} \in \{D_1^{\pm 1}\}$ , then  $H_{n_2} \in \{D_2^{\pm 1}\}$ , for all  $n_1 < n < n_2$ ,  $H_n = G^{-1}$  and  $n_2 - n_1 - 1 \geq N$ .
- If  $H_{n_1} \in \{D_2^{\pm 1}\}$ , then  $H_{n_2} \in \{D_1^{\pm 1}\}$ , for all  $n_1 < n < n_2$ ,  $H_n = G$  and  $n_2 - n_1 - 1 \geq N$ .

Thus, the bi-infinite words in  $\mathcal{H}_N(G, D_1, D_2)$  are those of the form :

$$\cdots D_1^{\pm 1} \underbrace{G^{-1} \cdots G^{-1}}_{\geq N} D_2^{\pm 1} \underbrace{G \cdots G}_{\geq N} D_1^{\pm 1} \underbrace{G^{-1} \cdots G^{-1}}_{\geq N} D_2^{\pm 1} \underbrace{G \cdots G}_{\geq N} D_1^{\pm 1} \cdots$$

We denote by  $\mathcal{G}_N(G, D_1, D_2)$  the set of bi-infinite sequences  $W = (W_n)_{n \in \mathbb{Z}} \in \mathcal{G}(G, D_1, D_2)$  associate to bi-infinite words in  $\mathcal{H}_N(G, D_1, D_2)$ .

Fix  $o$  a basepoint in  $X$ . Starting from a bi-infinite sequence  $W = (W_n)_{n \in \mathbb{Z}} \in \mathcal{G}(\mathcal{A}(G, D_1, D_2))$ , we define the sequence of points in  $X$  :  $x_n = W_n o, \forall n \in \mathbb{Z}$ . The goal of this section is to study the uniform quasi-geodesicity of sequences of points defined by the elements of  $\mathcal{G}_N(G, D_1, D_2)$ , that is the existence of two reals  $\lambda > 0$  and  $k \geq 0$  such that for all  $n, m \in \mathbb{Z}$ , we have :  $\frac{1}{\lambda}|n - m| - k \leq d(x_n, x_m) \leq \lambda|n - m| + k$ . We also say that  $(x_n)_{n \in \mathbb{Z}}$  is a  $(\lambda, k, L)$ -local-quasi-geodesic if we have  $\frac{1}{\lambda}|n - m| - k \leq d(x_n, x_m) \leq \lambda|n - m| + k$  whenever  $|n - m| \leq L$ . Precisely we prove the following lemma :

**Proposition 9.1.** *Let  $X$  be a  $\delta$ -hyperbolic space, geodesic and proper, and  $o \in X$  any basepoint. Pick  $G$  a hyperbolic isometry and  $D_1, D_2$  two isometries of  $X$ . Suppose that  $D_1(G^-) \neq G^-$  and  $D_2(G^+) \neq G^+$ . Then, there exists  $\lambda > 0, k \geq 0$  and  $N \in \mathbb{N}^*$ , such that for all bi-infinite sequence  $W = (W_n)_{n \in \mathbb{Z}} \in \mathcal{G}_N(G, D_1, D_2)$ , the sequence of points  $x_n = W_n o$  is a  $(\lambda, k)$ -quasi-geodesic.*

*Proof.* • **Step 1 : Quasi-isometry on a half-period**

The goal is at first to show that there exist two constants  $\lambda > 0$  and  $k \geq 0$ , only depending on  $\delta, G, \mathcal{F}_1, \mathcal{F}_2$  and  $o$ , such that the two following inequalities are satisfied :

$$\frac{1}{\lambda}|G^n D_1 G^{-m}| - k \leq d(G^n D_1 G^{-m} o, o) \quad \text{for all } n, m \geq 0 \quad (9.1)$$

$$\frac{1}{\lambda}|G^{-n} D_2 G^m| - k \leq d(G^{-n} D_2 G^m o, o) \quad \text{for all } n, m \geq 0 \quad (9.2)$$

By hypothesis, the two points at infinity  $D_1(G^-)$  and  $G^-$  are distinct, so we can consider a geodesic, called  $\Lambda$ , with endpoints  $D_1(G^-)$  and  $G^-$ . Such a geodesic exists because the space  $X$  is supposed to be proper. Now consider  $p$  a projection map on  $\Lambda$ , that is  $p : X \rightarrow \Lambda$  satisfying  $\forall x \in X, d(x, p(x)) = d(x, \Lambda) = \inf_{y \in \Lambda} d(x, y)$  (such a map exists but is not necessarily unique). Since  $(G^{-n} o)_{n \in \mathbb{N}}$  is a (half) quasi-geodesic with endpoint  $G^-$  and  $\Lambda$  is a geodesic with  $G^-$  as one of its endpoints, we have, by stability of quasi-geodesics in  $\delta$  hyperbolic spaces, the existence of a constant  $K_1 > 0$  (only depending on  $\delta, G, D_1$  and  $o$ ) such that  $\{G^{-n} o\}_{n \in \mathbb{N}}$  and the half geodesic  $[p(o), G^-)$  remain in the  $K_1$ -neighborhood of each other. We deduce the following inequality :

$$d(G^{-n} o, p(G^{-n} o)) \leq K_1, \text{ for all } n \in \mathbb{N} \quad (9.3)$$

With the same argument, namely that the (half) geodesic  $(D_1 G^{-m} o)_{m \in \mathbb{N}}$  and  $\Lambda$  share the same endpoint  $D_1(G^-)$ , we deduce the existence of a constant  $K_2 > 0$  (only depending on  $\delta, G, D_1$  and  $o$ ) such that

$$d(D_1 G^{-m} o, p(D_1 G^{-m} o)) \leq K_2, \text{ for all } m \in \mathbb{N}. \quad (9.4)$$

Then we can write the following inequalities :

$$\begin{aligned} d(G^n D_1 G^{-m} o, o) &= d(D_1 G^{-m} o, G^{-n} o) \text{ because } G^{-n} \text{ is an isometry} \\ &\geq d(p(D_1 G^{-m} o), p(G^{-n} o)) - d(p(D_1 G^{-m} o), D_1 G^{-m} o) - d(p(G^{-n} o), G^{-n} o) \\ &\geq d(p(D_1 G^{-m} o), p(G^{-n} o)) - K_1 - K_2 \text{ by inequalities 9.3 and 9.4.} \end{aligned}$$

But since  $G^{-n}o \xrightarrow[n \rightarrow \infty]{} G^-$ , we also have  $p(G^{-n}o) \xrightarrow[n \rightarrow \infty]{} G^-$ , and in the same way, since  $D_1G^{-m}o \xrightarrow[m \rightarrow \infty]{} D_1(G^-)$ , we deduce  $p(D_1G^{-m}o) \xrightarrow[m \rightarrow \infty]{} D_1(G^-)$ . Then, for  $n$  and  $m$  sufficiently large,  $p(G^{-n}o)$  belongs to  $[p(o), G^-] \cap [p(D_1o), G^-]$  and  $p(D_1G^{-m}o)$  belongs to  $[p(o), D_1(G^-)] \cap [p(D_1o), D_1(G^-)]$ . This shows that for  $n$  and  $m$  sufficiently large, the four points  $p(G^{-n}o), p(D_1G^{-m}o), p(D_1o)$  and  $p(o)$  are aligned in one of the two following orders on the geodesic  $\Lambda : p(G^{-n}o), p(o), p(D_1o), p(D_1G^{-m}o)$  or  $p(G^{-n}o), p(D_1o), p(o), p(D_1G^{-m}o)$ . In the first case

$$d(p(G^{-n}o), p(D_1G^{-m}o)) = d(p(G^{-n}o), p(o)) + d(p(o), p(D_1o)) + d(p(D_1o), p(D_1G^{-m}o))$$

and in the second one :

$$d(p(G^{-n}o), p(D_1G^{-m}o)) = d(p(G^{-n}o), p(o)) - d(p(o), p(D_1o)) + d(p(D_1o), p(D_1G^{-m}o))$$

so, in every case, for  $n$  and  $m$  sufficiently large :

$$d(p(G^{-n}o), p(D_1G^{-m}o)) \geq d(p(G^{-n}o), p(o)) - d(p(o), p(D_1o)) + d(p(D_1o), p(D_1G^{-m}o)). \quad (9.5)$$

On the other hand,

$$\begin{aligned} d(p(G^{-n}o), p(o)) &\geq d(G^{-n}o, o) - d(G^{-n}o, p(G^{-n}o)) - d(p(o), o) \\ &\geq d(G^{-n}o, o) - 2K_1 \text{ by inequality (9.3)} \end{aligned} \quad (9.6)$$

and similarly :

$$d(p(D_1G^{-m}o), p(D_1o)) \geq d(D_1G^{-m}o, D_1o) - 2K_2 \text{ by inequality (9.4)}. \quad (9.7)$$

We can now finish our sequence of inequalities :

$$\begin{aligned} d(G^n D_1 G^{-m} o, o) &\geq d(p(D_1 G^{-m} o), p(G^{-n} o)) - K_1 - K_2 \\ &\geq d(p(G^{-n} o), p(o)) - d(p(o), p(D_1 o)) + d(p(D_1 o), p(D_1 G^{-m} o)) - K_1 - K_2 \text{ by (9.5)} \\ &\geq d(G^{-n} o, o) + d(D_1 G^{-m} o, D_1 o) - d(p(o), p(D_1 o)) - 3K_1 - 3K_2 \text{ by (9.6) and (9.7)} \\ &= d(G^n o, o) + d(G^m o, o) - d(p(o), p(D_1 o)) - 3K_1 - 3K_2 \\ &\geq (n+m)l_S(G) - d(p(o), p(D_1 o)) - 3K_1 - 3K_2 \end{aligned}$$

In the last inequality, we used the basic fact that  $d(G^n o, o) \geq n l_S(G)$ , where  $l_S(G)$  denotes the stable length of the isometry  $G$ . Since  $(n+m)l_S(G) = (n+m+1)l_S(G) - l_S(G) = |G^n D_1 G^{-m}| l_S(G) - l_S(G)$ , we have proved the inequality (9.1) for  $n$  and  $m$  sufficiently large, prescribing  $\lambda = \frac{1}{l_S(G)}$  (recall  $l_S(G) > 0$  when  $G$  is hyperbolic), and  $k = l_S(G) + d(p(o), p(D_1 o)) + 3K_1 + 3K_2$ . Since there is only a finite number of values of  $G^n D_1 G^{-m}$ , for  $n$  and  $m$  smaller than a fixed constant, the inequality (9.1) is still true for all  $n, m \in \mathbb{N}$ , after possibly changing the values of  $\lambda$  and  $k$ .

In order to prove the inequality (9.2), we change  $D_1$  to  $D_2$  and  $G$  to  $G^{-1}$  and use the hypothesis  $D_2(G^+) \neq G^+$ .

• **Step 2 : From local to global quasi-isometry**

We shall now conclude the proof of Proposition 9.1 using the local-global lemma, given at the end of section 2.2 (Lemma 2.12).

Let  $L > 0$  and  $(\lambda', k')$  such as in Lemma 2.12, with  $\lambda$  and  $k$  defined in the first step. Fix  $N = \lfloor L \rfloor + 1$ . Then every interval of length smaller than  $L$  is of length smaller than  $N$ . Now choose  $W$  a sequence in  $\mathcal{G}_N(G, \mathcal{F}_1, \mathcal{F}_2)$  which is associate to a bi-infinite words  $H = (H_n)_{n \in \mathbb{Z}} \in \mathcal{H}_N(G, D_1, D_2)$ . Thus, the subwords of  $H$  of length smaller than  $L$  are all either of the form  $G^n$ ,  $G^{-n}$ ,  $G^n D_1 G^{-m}$ ,  $G^n D_1^{-1} G^{-m}$ ,  $G^n D_2 G^{-m}$ , or  $G^n D_2^{-1} G^{-m}$ , with  $n \geq 0, m \geq 0$ . The sequence  $(G^n o)_{n \in \mathbb{Z}}$  is a quasi-isometry (since  $G$  is hyperbolic), so there exist two constants  $\lambda_1 > 0, k_1 > 0$  such that  $\frac{1}{\lambda_1} |G^n| - k_1 \leq d(G^n o, o) = d(G^{-n} o, o)$  for all  $n \geq 0$ . Moreover, we have just proven in step 1 that there exists two constants  $\lambda_2 > 0, k_2 > 0$ , such that  $\frac{1}{\lambda_2} |G^n D_1 G^{-m}| - k_2 \leq d(G^{-n} D_2 G^m o, o)$ , for all  $n \geq 0, m \geq 0$ . Notice that we still have the same inequalities when replacing  $D_1$  by  $D_1^{-1}$  and  $D_2$  by  $D_2^{-1}$  (take the inverse of  $G^n D_1 G^{-m}$  and  $G^{-n} D_2 G^m$  and note that the word length and the displacement of the basepoint are unchanged). Therefore, the sequence of points  $(x_n = W_n o)_{n \in \mathbb{Z}}$  is a  $(\lambda, k, L)$ -local-quasi-geodesic. So, by the local-global lemma 2.12, there exists  $\lambda' \geq 1, k' \geq 0$  (only depending on  $\lambda$  and  $k$ , that is on  $\delta, G, \mathcal{F}_1, \mathcal{F}_2$  and  $o$ ), such that  $(x_n)_{n \in \mathbb{Z}}$  is a  $(\lambda', k')$ -quasi-geodesic (global). Thus, Proposition 9.1 is proved.  $\square$

## 9.2 Properties on Bowditch representations of $\pi_1(S_{0,4})$

Let  $(X, d)$  be a  $\delta$ -hyperbolic space, geodesic and proper, and  $o \in X$  a basepoint.

We establish the useful fact that the image of simple closed curves by a Bowditch representation are hyperbolic isometries. This result is similar to Lemma 5.2 for  $\mathbb{F}_2$  but uses the combinatorics of  $\mathcal{S}(S_{0,4})$  studied in section 8.3 which is a little more complicated than in the case of  $\mathbb{F}_2$ .

**Lemma 9.2.** *Let  $\rho : \pi_1(S_{0,4}) \rightarrow \text{Isom}(X)$  be a Bowditch representation with constant  $C, D$  and  $\gamma \in \mathcal{S}(S_{0,4})$ . Then  $\frac{1}{C} \|\gamma\| \leq l_S(\rho(\gamma))$  and  $\rho(\gamma)$  is hyperbolic.*

*Proof.* We assume (without loss of generality) that  $\gamma$  is cyclically reduced.

We introduce  $\delta_1, \delta_2 \in \pi_1(S_{0,4})$  given by Corollary 8.7. Therefore, by this corollary, for all  $n \in \mathbb{N}$ , the word  $\gamma^n \delta_1 \gamma^{-n} \delta_2$  is simple. In order to apply the Bowditch hypothesis to  $\gamma^n \delta_1 \gamma^{-n} \delta_2$ , we want to study the cyclically reduced word length of  $\gamma^n \delta_1 \gamma^{-n} \delta_2$ . The word  $\gamma^n \delta_1 \gamma^{-n} \delta_2$  is not necessarily reduced, but the key point is that  $\delta_1$  and  $\delta_2$  only depend on  $\gamma$  and not on  $n$ , so the possible simplifications in the word  $\gamma^n \delta_1 \gamma^{-n} \delta_2$  are independent of  $n$ , for  $n$  large enough. For completeness, let us write the details :

Consider two integers  $n_1$  and  $n_2$  satisfying  $n_1 |\gamma| > |\delta_1|$  and  $n_2 |\gamma| > |\delta_2|$ . Denote  $\delta'_1 = \gamma^{n_1} \delta_1 \gamma^{-n_1}$  and  $\delta'_2 = \gamma^{-n_2} \delta_2 \gamma^{n_2}$ . The elements  $\delta'_1 = \gamma^{n_1} \delta_1 \gamma^{-n_1}$  and  $\delta'_2 = \gamma^{-n_2} \delta_2 \gamma^{n_2}$  may have some simplifications, but because of the assumptions on  $n_1$  and  $n_2$  (and the fact that  $\gamma$  is cyclically reduced), the

simplifications are "bounded" in the sense that  $\delta'_1$  and  $\delta'_2$  are non empty (in fact they have at least two letters) and the following hold :

- the first letter of  $\delta'_1$  is equal to the first letter of  $\gamma$ ,
- the last letter of  $\delta'_1$  is equal to the inverse of the first letter of  $\gamma$ ,
- the first letter of  $\delta'_2$  is equal to the inverse of the last letter of  $\gamma$ ,
- the last letter of  $\delta'_2$  is equal to the last letter of  $\gamma$ .

Moreover, for all  $n \in \mathbb{N}$  we have :

$$\gamma^n \delta_1 \gamma^{-n} \delta_2 = \gamma^{n_2} \gamma^{n-n_1-n_2} \gamma^{n_1} \delta_1 \gamma^{-n_1} \gamma^{-n+n_1+n_2} \gamma^{-n_2} \delta_2$$

so the element  $\gamma^{n-n_1-n_2} \delta'_1 \gamma^{-n+n_1+n_2} \delta'_2$  is a cyclic permutation of  $\gamma^n \delta_1 \gamma^{-n} \delta_2$ . Now notice that the observations made above on the first and last letters of  $\delta'_1$  and  $\delta'_2$  imply that for all  $n \geq n_1 + n_2 + 1$  the word  $\gamma^{n-n_1-n_2} \delta'_1 \gamma^{-n+n_1+n_2} \delta'_2$  is cyclically reduced (here we write  $\delta'_1$  and  $\delta'_2$  as reduced word). In other words, for all  $n \in \mathbb{N}^*$ ,  $\gamma^n \delta'_1 \gamma^{-n} \delta'_2$  is simple and cyclically reduced.

Then, we use the Bowditch hypothesis on  $\gamma^n \delta'_1 \gamma^{-n} \delta'_2$  to write the following inequalities :

$$\begin{aligned} \frac{1}{C} \|\gamma^n \delta'_1 \gamma^{-n} \delta'_2\| - D &\leq d(\rho(\gamma^n \delta'_1 \gamma^{-n} \delta'_2) o, o) \\ &\leq d(\rho(\gamma^n) o, o) + d(\rho(\delta'_1) o, o) + d(\rho(\gamma^{-n}) o, o) + d(\rho(\delta'_2) o, o) \end{aligned}$$

But since  $\gamma^n \delta'_1 \gamma^{-n} \delta'_2$  is cyclically reduced, we have  $\|\gamma^n \delta'_1 \gamma^{-n} \delta'_2\| = 2n|\gamma| + |\delta'_1| + |\delta'_2| = 2n\|\gamma\| + |\delta'_1| + |\delta'_2|$  (the last equality holds since  $\gamma$  is supposed cyclically reduced), so after dividing by  $n$  :

$$\frac{2}{C} \|\gamma\| + \frac{|\delta'_1| + |\delta'_2|}{nC} - \frac{D}{n} \leq \frac{2}{n} d(\rho(\gamma^n) o, o) + \frac{1}{n} (d(\rho(\delta'_1) o, o) + d(\rho(\delta'_2) o, o))$$

And then by taking the limit when  $n \rightarrow \infty$  (and dividing by 2):

$$\frac{1}{C} \|\gamma\| \leq l_S(\rho(\gamma)) \quad \text{by definition of the stable length,}$$

which is the desired inequality.

Hence, for every simple word  $\gamma$ ,  $l_S(\rho(\gamma)) > 0$ , thus  $\rho(\gamma)$  is hyperbolic.  $\square$

Now we establish the fact that the hypothesis required by Lemma 9.1 is satisfied when the isometries  $D_1$ ,  $D_2$  and  $G$  comes from a Bowditch representation. Again, this result is similar to Lemma 5.3 in the case of  $\mathbb{F}_2$  but uses the combinatorics of  $\mathcal{S}(\mathbb{S}_{0,4})$ .

**Lemma 9.3.** *Let  $\rho : \pi_1(\mathbb{S}_{0,4}) \rightarrow \text{Isom}(X)$  be a Bowditch representation with constants  $C, D$  and  $\gamma \in \mathcal{S}(\mathbb{S}_{0,4})$ . Let  $\delta_1, \delta_2 \in \pi_1(\mathbb{S}_{0,4})$  such that  $\gamma^n \delta_1 \gamma^{-n} \delta_2$  is simple for an infinite number of  $n \in \mathbb{N}$ . Denote  $D_1 = \rho(\delta_1)$ ,  $D_2 = \rho(\delta_2)$  and  $G = \rho(\gamma)$ . Then  $D_1(G^-) \neq G^-$  and  $D_2(G^+) \neq G^+$ .*

Before starting the proof, recall that we have shown that  $G = \rho(\gamma)$  is an hyperbolic isometry (since  $\gamma$  is simple, see Lemma 9.2), therefore  $G^-$  and  $G^+$  are well-defined.

*Proof.* First notice that  $\gamma^n \delta_1 \gamma^{-n} \delta_2$  is not necessarily supposed cyclically reduced. However, in the same way as in the beginning of the proof of the previous Lemma (9.2), we can assume that  $\gamma^n \delta_1 \gamma^{-n} \delta_2$  is cyclically reduced after possibly conjugating  $\delta_1$  and  $\delta_2$  by a power of  $\gamma$  (independent of  $n$ ). This change does not affect the conclusion of the lemma : indeed, if  $D_1(G^-) \neq G^-$ , the same non-equality holds when changing  $D_1$  to a conjugate of  $D_1$  by any power of  $G$  (because  $G^-$  is a fixed point of  $G$ ), and the same is true for the non-equality  $D_2(G^+) \neq G^+$ . Thus in the following, we will assume that  $\gamma^n \delta_1 \gamma^{-n} \delta_2$  is cyclically reduced.

Choose a basepoint  $o \in X$  and consider the two sequences of points in  $X$  define by  $x_n = G^{-n}o$  and  $y_n = D_1 G^{-n}o$  for all  $n \in \mathbb{N}$ . By contradiction, assume that  $D_1(G^-) = G^-$ . Under this assumption, we want to show that the distance  $d(x_n, y_n)$  is bounded. Let  $l_{G^-}$  be any geodesic with  $G^-$  as an endpoint. Because  $G$  is a hyperbolic isometry, the sequence  $(G^{-n}o)_{n \in \mathbb{Z}} = (x_n)_{n \in \mathbb{Z}}$  is a quasi-isometry with attracting fixpoint  $G^-$ . Furthermore,  $(D_1 G^{-n}o)_{n \in \mathbb{Z}} = (y_n)_{n \in \mathbb{Z}}$  is also a quasi-isometry with attracting fixpoint  $D_1(G^-)$ . Thus, under this assumption  $D_1(G^-) = G^-$ , the sequences  $(x_n)_{n \in \mathbb{Z}}$  and  $(y_n)_{n \in \mathbb{Z}}$  are both quasi-geodesics with the same attracting fixpoint,  $G^-$ . Hence, the stability of quasi-geodesic in  $\delta$ -hyperbolic spaces gives the existence of a constant  $K > 0$  such that  $(x_n)_{n \in \mathbb{N}}$  and  $(y_n)_{n \in \mathbb{N}}$  both stay at a distance at most  $K$  of  $l_{G^-}$ . Now consider a projection  $p : X \rightarrow l_{G^-}$  on the geodesic  $l_{G^-}$ . By definition of the projection we have that for all  $n \in \mathbb{N}$ ,  $d(x_n, p(x_n)) \leq K$ ,  $d(y_n, p(y_n)) \leq K$ . Then we deduce :

$$d(x_n, y_n) \leq d(p(x_n), p(y_n)) + 2K \quad (9.8)$$

Moreover, because  $p(x_n), p(y_n)$  and  $p(o)$  all belong to the same geodesic  $l_{G^-}$ , we can write :

$$d(p(x_n), p(y_n)) = |d(p(x_n), p(o)) - d(p(y_n), p(o))|. \quad (9.9)$$

Using again that  $(x_n)_{n \in \mathbb{N}}$  and  $(y_n)_{n \in \mathbb{N}}$  both stay at a distance at most  $K$  of  $l_{G^-}$ , we obtain the two following inequalities :

$$\begin{aligned} d(x_n, o) - 2K &\leq d(p(x_n), p(o)) \leq d(x_n, o) + 2K \\ d(y_n, o) - 2K &\leq d(p(y_n), p(o)) \leq d(y_n, o) + 2K \end{aligned}$$

from which we deduce :

$$|d(p(x_n), p(o)) - d(p(y_n), p(o))| \leq |d(x_n, o) - d(y_n, o)| + 4K. \quad (9.10)$$

Finally, we bound  $|d(x_n, o) - d(y_n, o)|$  using the triangle inequality :

$$\begin{aligned} |d(x_n, o) - d(y_n, o)| &= |d(G^{-n}o, o) - d(D_1 G^{-n}o, o)| \\ &= |d(D_1 G^{-n}o, D_1 o) - d(D_1 G^{-n}o, o)| \\ &\leq d(D_1 o, o) \end{aligned}$$

and then, together with (9.8), (9.9) and (9.10), we conclude that  $d(x_n, y_n)$  is bounded. But by hypothesis,  $\gamma^n \delta_1 \gamma^{-n} \delta_2$  is simple for an infinite number of  $n \in \mathbb{N}$ , so we can conclude using the Bowditch inequality that, for an infinite number of  $n$  :

$$\begin{aligned} \frac{1}{C} \|\gamma^n \delta_1 \gamma^{-n} \delta_2\| - D &\leq d(\rho(\gamma^n \delta_1 \gamma^{-n} \delta_2) o, o) = d(G^{-n} o, D_1 G^{-n} D_2 o) \\ &\leq d(G^{-n} o, D_1 G^{-n} o) + d(D_1 G^{-n} o, D_1 G^{-n} D_2 o) \\ &= d(x_n, y_n) + d(D_2 o, o) \end{aligned}$$

Hence the right hand side of this inequality is bounded in  $n$  whereas the left hand side is not (recall that  $\gamma^n \delta_1 \gamma^{-n} \delta_2$  is supposed cyclically reduced), this is a contradiction. From this contradiction we deduce that  $D_1(G^-) \neq G^-$ .

Finally notice that if  $\gamma^n \delta_1 \gamma^{-n} \delta_2$  is simple, so is  $\gamma^{-n} \delta_2 \gamma^n \delta_1$ . Thus using what has been previously done we also have that  $D_2((G^{-1})^-) \neq (G^{-1})^-$ . Since  $(G^{-1})^- = G^+$ , the lemma is proved.  $\square$





# Chapter 10

## From Bowditch's hypothesis for $\pi_1(\mathbb{S}_{0,4})$ to uniform tubular neighborhoods

The purpose of this section is to show Proposition 10.1 which is, as in the case of  $\mathbb{F}_2$ , the heart of the proof that a Bowditch representation of the fundamental group of the sphere  $\mathbb{S}_{0,4}$  is simple-stable.

**Proposition 10.1.** *Let  $X$  be a  $\delta$ -hyperbolic space, geodesic and proper.*

*Let  $\rho : \pi_1(\mathbb{S}_{0,4}) \rightarrow \text{Isom}(X)$  be a Bowditch representation. The orbit map restricted to simple leaves stays in a uniform tubular neighborhood of the axes of simple elements in  $X$ . Precisely :*

$$\exists K > 0, \quad \forall \gamma \in \mathcal{S}(\mathbb{S}_{0,4}), \quad \tau_\rho(L_\gamma) \subset N_K(\text{Axis}(\rho(\gamma)))$$

Recall that  $L_\gamma$  denotes the geodesic in the Cayley graph of  $\pi_1(\mathbb{S}_{0,4}) = \mathbb{F}_3$  generated by  $\gamma$ , and that for any element  $\gamma \in \mathcal{S}(\mathbb{S}_{0,4})$ , we prove in Lemma 9.2 that  $\rho(\gamma)$  is hyperbolic so  $\text{Axis}(\rho(\gamma))$  is well-defined.

*Proof.* Pick  $\rho : \pi_1(\mathbb{S}_{0,4}) \rightarrow \text{Isom}(X)$  a Bowditch representation of  $\pi_1(\mathbb{S}_{0,4})$ ,  $o \in X$  a basepoint and let  $C, C' > 0$  be two constants such that :

$$\forall \gamma \in \mathcal{S}(\mathbb{S}_{0,4}), \quad \frac{1}{C} \|\gamma\| \leq l(\rho(\gamma)) \quad \text{and} \quad \forall u \in \pi_1(\mathbb{S}_{0,4}), \quad d(\rho(u)o, o) \leq C'. \quad (10.1)$$

Recall that the existence of the constant  $C$  comes from the hypothesis that the representation is Bowditch and Lemma 9.2 and the existence of the constant  $C'$  is true for any representation of a finitely generated group. Note that such constants automatically satisfy  $CC' \geq 1$ .

Let us proceed as in the case of  $\mathbb{F}_2$  by contradiction and suppose that there exists a sequence  $(\gamma_n)_{n \in \mathbb{N}}$  of simple elements in  $\mathcal{S}(\mathbb{S}_{0,4})$  satisfying the following hypothesis :

$$\sup\{d(x, \text{Axis}(\rho(\gamma_n))) \mid x \in \tau_\rho(L_{\gamma_n})\} \xrightarrow{n \rightarrow \infty} +\infty \quad (H_2)$$

Such a sequence is now fixed.

We can assume that the elements  $\gamma_n$  are pairwise distinct and that  $|\gamma_n| \rightarrow \infty$ . The proof of this fact is exactly the same as in the case of the group  $\mathbb{F}_2$ , see Lemma 6.4.

## 10.1 Continued fraction expansion of $\gamma_n$

The element  $\gamma_n$  is simple, thus by Proposition 8.1 corresponds to a rational, and then we can write the continued fraction expansion of its slope :

$$\text{Slope}(\gamma_n) = [N_1^n, \dots, N_{r(n)}^n].$$

Now we will prove that we can restrict our study to the case where the integers  $N_i^n$  are bounded in  $n$  :

**Lemma 10.2.** *Up to subsequence,  $r(n) \rightarrow \infty$  and for all  $i \in \mathbb{N}$ ,  $(N_i^n)_{n \in \mathbb{N} \mid r(n) \geq i}$  is bounded.*

*Proof.* Suppose there exists  $k \in \mathbb{N}$  such that  $(N_k^n)_n$  is defined for infinitely many values of  $n$  and is not bounded. Then consider the integer  $0 \leq i$  such that  $(N_{i+1}^n)_n \xrightarrow{n \rightarrow \infty} \infty$  (after passing to subsequence) and for all  $1 \leq j \leq i$ , the sequence  $(N_j^n)_n$  is bounded. Therefore, again after passing to subsequence we assume that for all  $1 \leq j \leq i$  there exists an integer  $N_j$  such that for all  $n \in \mathbb{N}$  such that  $r(n) \geq j$ ,  $N_j^n = N_j$ . Thus  $\text{Slope}(\gamma_n) = [N_1, \dots, N_i, N_{i+1}^n, \dots, N_{r(n)}^n]$ . Now, use Lemma 8.8 to deduce the existence of a simple word  $\gamma_i \in \mathcal{S}(S_{0,4})$  of slope  $[N_1, \dots, N_i]$  and two words  $\delta_1, \delta_2 \in \pi_1(S_{0,4})$ , such that for all  $n \in \mathbb{N}$ ,  $\gamma_n$  can be written as a (cyclic-permutation of a) concatenation of subwords of the form :

$$(\gamma_i)^{m_1(n)} \tilde{\delta}_1 (\gamma_i)^{-m_2(n)} \tilde{\delta}_2,$$

with  $m_1(n), m_2(n) \geq \frac{N_{i+1}^n - 1}{2}$ ,  $\tilde{\delta}_1 \in \{\delta_1, \delta_1^{-1}\}$  and  $\tilde{\delta}_2 \in \{\delta_2, \delta_2^{-1}\}$ .

Now set  $G = \rho(\gamma_i)$ ,  $D_1 = \rho(\delta_1)$  and  $D_2 = \rho(\delta_2)$ . Then, by considering the bi-infinite word obtained by concatenating infinitely many copies of  $\gamma_n$ , or equivalently the bi-infinite word obtained by following the geodesic  $L_{\gamma_n}$  in the Cayley graph, we can see  $\rho_{L_{\gamma_n}}$  as an element of  $\mathcal{G}(G, D_1, D_2)$  (the definition is given at the beginning of section 9). Let us introduce the constants  $\lambda > 0, k \geq 0$  and  $N \in \mathbb{N}^*$  as defined in Lemma 9.1. For  $n$  sufficiently large,  $m_1(n) \geq N$  and  $m_2(n) \geq N$  because  $m_1(n), m_2(n) \geq \frac{N_{i+1}^n - 1}{2}$ , and by hypothesis  $N_{i+1}^n \xrightarrow{n \rightarrow \infty} \infty$ . Hence,  $\rho_{L_{\gamma_n}}$  is an element of  $\mathcal{G}_N(G, D_1, D_2)$  for  $n$  sufficiently large. Let us now use the second part of Lemma 8.8 to justify that for all  $n \in \mathbb{N}$ , the word  $(\gamma_i)^n \delta_1 (\gamma_i)^{-n} \delta_2$  is simple. Then, by Lemma 9.3, we obtain that  $D_1(G^-) \neq G^-$  and  $D_2(G^+) \neq G^+$ . Now we can apply Proposition 9.1 to justify that  $\tau_\rho(\gamma_n)$  are uniform (in  $n$ ) quasi-geodesic in  $X$ .

This contradicts our hypothesis  $(H_2)$  on  $\rho$  for  $n$  sufficiently large. Hence, for all  $i \in \mathbb{N}$ ,  $(N_i^n)_n$  is bounded.

Let us now justify that  $r(n) \rightarrow +\infty$ . If  $r(n)$  stays bounded,  $r(n) \leq R$ , then for all  $1 \leq i \leq R$ ,  $(N_i^n)_n$  is bounded by what has been previously done and so the word length of  $\gamma_n$  is also bounded, which is false. Thus  $r(n) \rightarrow +\infty$ .

In particular, we deduce that under the assumption  $(H_2)$ , the sequence  $(N_i^n)_n$  is always well-defined for  $n$  sufficiently large ( $n$  such that  $r(n) \geq i$ ).  $\square$

## 10.2 Consequence : uniform bound on the lengths $l_i(\gamma_n)$

As in section 6.2, we introduce the constants  $N_i$  such that  $N_i^n \leq N_i$  for all integer  $n$  and we obtain the following uniform bound on the lengths  $l_i(\gamma_n)$  :

$$\forall n \in \mathbb{N}, \forall 1 \leq i \leq r(n), \quad \frac{l_i(\gamma_n)}{l_{i-1}(\gamma_n)} \leq N_i + 1. \quad (10.2)$$

We deduce for every integer  $i$  the existence of constants  $L_i > 0$  such that :

$$\forall n \in \mathbb{N}, \forall 0 \leq i \leq r(n), \quad i \leq l_i(\gamma_n) \leq L_i. \quad (10.3)$$

## 10.3 Excursions of the orbit map

As in the section 6.4, we now want to define and study the excursions of the orbit map. Let  $\gamma$  be a cyclically reduced simple element in  $\mathcal{S}(S_{0,4})$ . Recall that  $L_\gamma$  is the axis of  $\gamma$  in the Cayley graph of  $\pi_1(S_{0,4}) = \mathbb{F}_3$ . We introduce the map  $E_\gamma : L_\gamma \rightarrow \mathbb{R}_+$  such that  $E_\gamma(u) = d(\tau_\rho(u), \text{Axis}(\rho(\gamma)))$ .

**Lemma 10.3.** *The map  $E_\gamma$  is Lipschitz-continuous (hence continuous) and  $\gamma$ -invariant.*

*Proof.* The proof is exactly the same as in Lemma 6.12. □

Now recall that, since  $L_\gamma$  is isometric to  $\mathbb{R}$ , we can therefore think of  $E_\gamma$  as a map from  $\mathbb{R}$  to  $\mathbb{R}$  and thus, we can apply the language of excursions defined in section 6.3.

Here we recall the definition of an excursion for the orbit map already introduced in the context of  $\mathbb{F}_2$  in Definition 6.4.

**Definition 10.1.** Let  $\gamma$  be a simple element in  $\mathcal{S}(S_{0,4})$ . Let  $[u, v] \subset L_\gamma$  be a segment of the geodesic  $L_\gamma$ . We say that  $[u, v]$  is an *excursion* if the map  $E_{\gamma|_{[u,v]}}$  is an excursion.

Let  $K \geq 0$ . We say that  $[u, v]$  is a *K-excursion* if the map  $E_{\gamma|_{[u,v]}}$  is an excursion such that  $E_\gamma(u) = K$ . In this case, we call *length of excursion* of  $[u, v]$  the length of excursion of  $E_{\gamma|_{[u,v]}}$ , that is the non-negative real  $d(u, v)$ .

At last, we say that  $\gamma$  has an excursion (respectively a *K-excursion*) if there exists  $[u, v] \in L_\gamma$  such that  $[u, v]$  is an excursion (respectively a *K-excursion*).

We end this section by showing that, as in the context of  $\mathbb{F}_2$ , there exists excursions as large and as long as we want.

**Lemma 10.4.** *There exist two sequences of positive reals  $(K_n)_{n \in \mathbb{N}}$  and  $(l_n)_{n \in \mathbb{N}}$ , such that  $K_n \rightarrow \infty$ ,  $l_n \rightarrow \infty$  and, up to subsequence, for all  $n \in \mathbb{N}$ ,  $\gamma_n$  has a  $K_n$ -excursion of length  $l_n$ .*

*Proof.* The proof is exactly the same as in the context of  $\mathbb{F}_2$ , see Lemma 6.13. □

## 10.4 Quasi-loops

We introduce quasi-loops, as in the context of  $\mathbb{F}_2$ . Here again, nothing is changed.

**Definition 10.2.** Let  $\varepsilon > 0$  and  $w \in \pi_1(S_{0,4}) = \mathbb{F}_3$  (not necessarily simple). We say that  $w$  is an  $\varepsilon$ -quasi-loop if we have the following inequality :

$$d(\rho(w)o, o) \leq \varepsilon |w|$$

Let  $\gamma$  be a simple element in  $\mathcal{S}(S_{0,4})$  and  $u \in L_\gamma$ . We denote by  $\lfloor u \rfloor$  the integer point in  $L_\gamma$  just before  $u$  (if  $u$  is an integer point in  $L_\gamma$ ,  $\lfloor u \rfloor = u$ ) and  $\lceil u \rceil$  the integer point of  $L_\gamma$  strictly just after  $u$  (thus  $\lfloor u \rfloor$  and  $\lceil u \rceil$  are the endpoints of an edge of length 1 in the Cayley graph and  $u$  belongs to this edge).

As in the context of  $\mathbb{F}_2$ , by considering very large excursions we obtain quasi-loops.

**Lemma 10.5.** *Let  $\varepsilon > 0$ . There exist  $l_\varepsilon > 0$  and  $K_\varepsilon > 0$  such that for all simple elements  $\gamma \in \mathcal{S}(S_{0,4})$ , for all  $K \geq K_\varepsilon, l \geq l_\varepsilon$ , if  $[u, v]$  is a  $K$ -excursion of length  $l$ , then the element  $w = \lfloor u \rfloor^{-1} \lceil v \rceil$  (which is a subword of  $\gamma$ ) is an  $\varepsilon$ -quasi-loop.*

*Proof.* The proof is exactly the same as in the context of  $\mathbb{F}_2$ , see Lemma 6.14, and relies mainly on the geometry of large uniform neighborhoods of geodesics in  $X$ .  $\square$

## 10.5 Induction step

We are now going to show the equivalent of Lemma 6.17 for the four-punctured sphere.

**Lemma 10.6.** *Let  $\beta = \frac{1}{480}$  ( $= \frac{\alpha}{16}$ , where  $\alpha$  is the constant introduced in Proposition 8.16).*

*Let  $0 < \varepsilon < \frac{1}{C}$  and  $r > 0$ . There exists a constant  $R > 0$  and an integer  $n_0 \in \mathbb{N}$ , such that, given any integer  $n \geq n_0$  and subword  $u$  of  $\gamma_n$  such that  $|u| \geq R$ , there exists a positive integer  $q \in \mathbb{N}^*$ , a subset  $QL \subset \{1, \dots, q\}$  and  $q$  words  $u_1, \dots, u_q \in \mathbb{F}_2$  such that :*

1.  $u = u_1 \cdots u_q$
2. For all  $k \in QL$ ,  $u_k$  is an  $\varepsilon$ -quasi-loop
3.  $\sum_{k \in QL} |u_k| \geq \beta |u|$
4. For all  $k \notin QL$ ,  $|u_k| \geq r$

*Proof.* Let us first introduce the constants  $K_\varepsilon$  and  $l_\varepsilon$  defined by Lemma 10.5. Now we choose and fix for the rest of the proof an integer  $i$  satisfying  $i \geq \max(10, 2r + 7, 2l_\varepsilon + 5)$ . Recall that the constant  $L_i$  has been introduced in (10.3). Let us also introduce the sequences  $(K_n)_{n \in \mathbb{N}}$  and  $(l_n)_{n \in \mathbb{N}}$  of Lemma 10.4. Since  $K_n \rightarrow +\infty$  and  $l_n \rightarrow +\infty$ , we can find an integer  $n_0$  such that for

all  $n \geq n_0$ , we have  $K_n \geq K_\varepsilon, l_n \geq l_\varepsilon$  and  $L_i - 5 < l_n$ . We also set  $\alpha$  to be the constant defined in Proposition 8.16 ( $\alpha = \frac{1}{30}$ , but its precise value does not matter, as long as it is a universal constant). Finally, we fix  $R$  such that  $R \geq \frac{3L_i}{\alpha}$ . Note that due to the value of the constant  $\alpha$ , we also automatically have  $R \geq 9L_i$ . Now let us show that with this choices for  $R$  and  $n_0$ , the lemma is true.

Let  $n \geq n_0$  and  $u$  be a subword of (a cyclic-permutation of)  $\gamma_n$  (or its inverse) such that  $|u| \geq R$ . By Lemma 10.4,  $\gamma_n$  has a  $K_n$ -excursion of length  $l_n$ . Moreover, we have  $l_i(\gamma_n) \leq L_i$  by (10.3) so in particular  $l_i(\gamma_n) - 5 < l_n$ . Therefore, we can use Lemma 6.11 to ensure the existence of a  $K'_n$ -excursion of length  $l'_n$ , with  $\frac{l_i(\gamma_n) - 5}{2} \leq l'_n < l_i(\gamma_n) - 5$  and  $K'_n \geq K_n$ . Denote it by  $[x, y] \subset L_{\gamma_n}$ . But then we have

$$\begin{aligned} l'_n &\geq \frac{l_i(\gamma_n) - 5}{2} \geq \frac{i - 5}{2} && \text{by (10.3)} \\ &\geq l_\varepsilon && \text{by the definition of } i \\ \text{and } K'_n &\geq K_n \geq K_\varepsilon, \end{aligned}$$

so we can apply Lemma 10.5 to ensure that the element  $v = [x]^{-1}[y]$  (which is a subword of  $\gamma$ ) is an  $\varepsilon$ -quasi-loop. Let us compute the length of  $v$  :

$$\begin{aligned} \text{We have } |v| &= d([x], [y]) = d([x], x) + d(x, y) - d(y, [y]) \\ \text{so } d(x, y) - 1 &< |v| < d(x, y) + 1 \\ \text{and } l'_n - 1 &< |v| < l'_n + 1 && \text{since } d(x, y) = l'_n \\ \text{then } \frac{l_i(\gamma_n) - 5}{2} - 1 &< |v| < l_i(\gamma_n) - 5 + 1 \\ \text{and finally } \frac{l_i(\gamma_n) - 7}{2} &\leq |v| \leq l_i(\gamma_n) - 5 && \text{because } |v| \text{ and } l_i(\gamma_n) \text{ are integers.} \end{aligned} \quad (10.4)$$

Now consider  $w$  the subword of  $\gamma_n$  of length  $l_i(\gamma_n) - 5$  such that  $v$  is a prefix of  $w$  and let us write  $w = vv'$ , with  $|w| = l_i(\gamma_n) - 5$ .

We are now going to use Proposition 8.16 for the subword  $u$  of  $\gamma_n$  and  $w$ . This is possible because we have :

- chosen  $i$  such that  $l_i(\gamma_n)$  is sufficiently large :  $l_i(\gamma) \geq i \geq 10$ ,
- chosen  $w$  of the right length :  $|w| = l_i(\gamma_n) - 5$ ,
- fix  $u$  sufficiently large :

$$\begin{aligned} |u| &\geq R \geq 9L_i && \text{by definition of } R \\ &\geq 9l_i(\gamma_n) = 3(2l_i(\gamma) + l_i(\gamma)) \geq 3(l'_i(\gamma_n) + 1 + l_i(\gamma)) && \text{by inequality (4.7)}. \end{aligned}$$

Then we can write  $u = u_1 \cdots u_q$  such that there exists a subset  $\mathcal{I} \subset \{1, \dots, q\}$  satisfying :

1. For all  $k \in \mathcal{I}$ ,  $u_k \in \{w, w^{-1}\}$ .

$$2. \sum_{k \in \mathcal{I}} |u_k| \geq \alpha |u|.$$

But recall that  $w = vv'$ , so the inverse is  $w^{-1} = v'^{-1}v^{-1}$ . Then for all  $k \in \mathcal{I}$ , we can write  $u_k = vv'$  or  $u_k = v'^{-1}v^{-1}$ . Therefore, the word  $u$  can be written as a concatenation of the subwords  $u_k$  for  $k \notin \mathcal{I}$  and  $v, v', v^{-1}, v'^{-1}$ , with at least  $\#\mathcal{I}$  terms of the form  $v$  or  $v^{-1}$ . Thus, by denoting  $v_k$  these  $\#\mathcal{I}$  appearances of  $v$  and  $v^{-1}$  and by combining together all successive terms that are not  $v$  or  $v^{-1}$  (that is all successive terms of the form  $u_k$  for  $k \notin \mathcal{I}, v', v'^{-1}$ ) into factors called  $v'_k$ , we can write the following concatenation of  $u$  :

$$u = v'_1 v_1 v'_2 v_2 \cdots v'_p v_p v'_{p+1}$$

satisfying :

- $p = \#\mathcal{I}$
- For all  $k \in \{1, \dots, p\}$ ,  $v_k \in \{v, v^{-1}\}$ .

Now let us show the four points of Lemma 10.6 :

1. If  $p$  is odd, we combine the previous terms together as follows :

$$\begin{aligned} u &= \underbrace{v'_1 v_1 v'_2}_{v''_1} v_2 \underbrace{v'_3 v_3 v'_4}_{v''_3} \cdots v_{p-1} \underbrace{v'_p v_p v'_{p+1}}_{v''_p} \\ u &= v''_1 v_2 v''_3 \cdots v_{p-1} v''_p \end{aligned} \quad (10.5)$$

If  $p$  is even, we combine the previous terms together as follows :

$$\begin{aligned} u &= \underbrace{v'_1 v_1 v'_2}_{v''_1} v_2 \underbrace{v'_3 v_3 v'_4}_{v''_3} \cdots v_{p-2} \underbrace{v'_{p-1} v_{p-1} v'_p v_p v'_{p+1}}_{v''_{p-1}} \\ u &= v''_1 v_2 v''_3 \cdots v_{p-2} v''_{p-1} \end{aligned} \quad (10.6)$$

and this will be our decomposition of  $u$ , with  $q = p$  if  $p$  is odd and  $q = p - 1$  if  $p$  is even,  $u_k = v''_k$  if  $k$  is odd and  $u_k = v_k$  if  $k$  is even, and  $QL = \{1 \leq k \leq p - 1 \mid k \text{ is even}\}$ .

2. Let  $k \in \{1, \dots, p\}$ , then  $v_k \in \{v, v^{-1}\}$ . But recall that by construction,  $v$  is an  $\varepsilon$ -quasi-loop, then so is  $v^{-1}$ , hence  $v_k$  is always an  $\varepsilon$ -quasi-loop.

3. Let us start by showing that  $p \geq 3$ .

$$\begin{aligned} pL_i &\geq pl_i(\gamma_n) && \text{by definition of } L_i \\ &\geq \#\mathcal{I}(l_i(\gamma_n) - 5) = \sum_{k \in \mathcal{I}} |u_k| && \text{since } p = \#\mathcal{I} \text{ and } |u_k| = |w| = l_i(\gamma_n) - 5 \\ &\geq \alpha |u| && \text{using point 2 of Proposition 8.16} \\ &\geq \alpha R && \text{by hypothesis on } u \\ &\geq \alpha \frac{3L_i}{\alpha} = 3L_i && \text{since } R \text{ is fixed such that } R \geq \frac{3L_i}{\alpha} \end{aligned}$$

and thus we deduce  $p \geq 3$ .

This ensures that in our previous decomposition (10.5) and (10.6), there is at least one term  $v_k$ . Indeed, recall that  $QL = \{1 \leq j \leq p-1 \mid j \text{ is even}\}$ . In particular we have :

$$p = \begin{cases} 2\#QL + 1 & \text{if } p \text{ is odd} \\ 2\#QL + 2 & \text{if } p \text{ is even} \end{cases}$$

$$\text{so in any cases} \quad p \leq 2\#QL + 2. \quad (10.7)$$

$$\text{and therefore} \quad 1 \leq \#QL. \quad (10.8)$$

Let us show that  $\sum_{k \in QL} |v_k| \geq \beta|u|$  :

$$\begin{aligned} |u| &\leq \frac{1}{\alpha} \sum_{k \in \mathcal{I}} |u_k| && \text{by point 2 of Proposition 8.16} \\ &\leq \frac{1}{\alpha} \#\mathcal{I}|w| && \text{by point 1 of Proposition 8.16} \\ &\leq \frac{1}{\alpha} p(l_i(\gamma_n) - 5) && \text{since } \#\mathcal{I} = p \text{ and } |w| = l_i(\gamma_n) - 5 \\ &\leq \frac{1}{\alpha} (2\#QL + 2)(l_i(\gamma_n) - 5) && \text{by the inequality (10.7)} \\ &\leq \frac{4}{\alpha} \#QL(l_i(\gamma_n) - 5) && \text{by the inequality (10.8)} \\ &\leq \frac{4}{\alpha} \#QL(2|v| + 2) && \text{using (10.4)} \end{aligned}$$

In addition :

$$|v| \geq \frac{l_i(\gamma_n) - 7}{20} \geq \frac{i - 7}{2} \geq \frac{10 - 7}{2} \geq 1$$

Then

$$|u| \leq \frac{4}{\alpha} \#QL \times 4|v| \leq \frac{16}{\alpha} \sum_{k \in QL} |v_k| \quad \text{since } v_k \in \{v, v^{-1}\}$$

and thus we have the desired inequality with  $\beta = \frac{\alpha}{16} (= \frac{1}{480})$ .

4. Finally, let  $k \notin QL$ , and let us compute the length of  $v_k''$  :

$$\begin{aligned} |v_k''| &\geq |v_k' v_k v_{k+1}'| && \text{(and there is in fact equality unless } p \text{ is even and } k = p - 1) \\ &\geq |v_k| = |v| && \text{by definition of } v_k \\ &\geq \frac{l_i(\gamma_n) - 7}{2} && \text{by (10.4)} \\ &\geq \frac{i - 7}{2} && \text{by inequality (10.3)} \\ &\geq r && \text{since } i \text{ has been chosen such that } i \geq 2r + 7. \end{aligned}$$

And this finishes the proof. □



## 10.6 Final contradiction and conclusion

Once we have Lemma 10.6, the end of the proof of Proposition 10.1 is the same as in the case of  $\mathbb{F}_2$ .

For completeness, we recall the last steps.

We are now able to find a simple word  $\gamma$  (from the sequence  $(\gamma_n)_{n \in \mathbb{N}}$ ) which contains a very large proportion of quasi-loops.

**Lemma 10.7.** *Let  $0 < \varepsilon < \frac{1}{C}$  and  $1 - \frac{1}{C'}(\frac{1}{C} - \varepsilon) < \lambda < 1$ . There exists a simple word  $\gamma$  such that  $\gamma$  contains  $\varepsilon$ -quasi-loops that occupy at least a proportion  $\lambda$  of  $\gamma$ .*

*Proof.* The proof is the same as the proof of Lemma 6.18, using Lemma 10.6. □

Then we show that if such an element exists, we obtain an inequality on the displacement of the basepoint  $o$ .

**Lemma 10.8.** *Let  $0 < \varepsilon < \frac{1}{C}$  and  $1 - \frac{1}{C'}(\frac{1}{C} - \varepsilon) < \lambda < 1$ . Let  $\gamma$  be a simple word in  $\mathbb{F}_2$  which contains  $\varepsilon$ -quasi-loops which occupy at least a proportion  $\lambda$  of  $\gamma$ . Then*

$$d(\rho(\gamma)o, o) < \frac{1}{C}|\gamma|.$$

*Proof.* The proof is the same as in the proof of Lemma 6.19. □

And thus this inequality contradicts the Bowditch hypothesis (10.1), so we found a contradiction. Proposition 10.1 is proved. □

# Chapter 11

## From uniform tubular neighborhoods and Bowditch's hypothesis for $\pi_1(S_{0,4})$ to simple-stability

### 11.1 A few complements on continuous maps

Before starting the last step of the proof of Theorem 1.4, we need to state a few Lemmas on continuous map. They are analogous to those of section 6.3.

**Lemma 11.1.** *Let  $x < y$  be two reals and  $f : [x, y] \rightarrow \mathbb{R}$  be a continuous map. Let  $\varepsilon > 0$ . Denote  $l = |y - x|$ . Let us define :*

$$L_{f,\varepsilon} = \{l' \in [0, l] \mid \exists(x', y') \in [x, y]^2, l' = |y' - x'| \text{ and } |f(y') - f(x')| \leq \varepsilon|y' - x'|\}$$

*Then the set  $L_{f,\varepsilon}$  is a closed subset of  $[0, l]$ .*

*Proof.* Let  $(l_n)_{n \in \mathbb{N}}$  be a sequence of  $L_{f,\varepsilon}$  such that  $l_n \rightarrow l_\infty \in [0, l]$ . Let  $(x_n)_{n \in \mathbb{N}}$  and  $(y_n)_{n \in \mathbb{N}}$  be two sequences of  $[x, y]$  such that  $|f(y_n) - f(x_n)| \leq \varepsilon(y_n - x_n)$  and  $y_n - x_n = l_n$ . Up to subsequence, since  $[x, y]$  is compact, we can assume that  $x_n \rightarrow x_\infty \in [x, y]$  and  $y_n \rightarrow y_\infty \in [x, y]$ . Then by continuity, we obtain  $|f(y_\infty) - f(x_\infty)| \leq \varepsilon(y_\infty - x_\infty)$  and thus  $l_\infty \in L_{f,\varepsilon}$ .  $\square$

**Lemma 11.2.** *Let  $x < y$  be two reals and  $f : [x, y] \rightarrow \mathbb{R}$  be a continuous map. Let  $\varepsilon > 0$  such that  $|f(y) - f(x)| \leq \varepsilon|y - x|$ . Denote  $l = |y - x|$ . There exists two reals  $x', y' \in [x, y]$  such that  $\frac{l}{2} \leq |y' - x'| < l$  and  $|f(y') - f(x')| \leq \varepsilon|y' - x'|$ .*

*Proof.* Let us define  $s = \frac{f(y) - f(x)}{y - x}$ . Then by hypothesis on  $f$  we have  $|s| \leq \varepsilon$ .

- Suppose that there exists  $x < z < y$  such that  $f(z) = f(x) + s(z - x)$ . Then both  $f(z) - f(x) = s(z - x)$  and  $f(y) - f(z) = s(y - z)$ . Moreover either  $z - x \geq \frac{y - x}{2} = \frac{l}{2}$  or  $y - z \geq \frac{y - x}{2} = \frac{l}{2}$ , and thus the claim is proved by setting  $l' = z - x$  or  $l' = y - z$ .

- Now suppose that for all  $x < z < y$ ,  $f(z) \neq f(x) + s(z - x)$ . Then by continuity, we have that for all  $x \leq z \leq y$ ,  $f(z) \geq f(x) + s(z - x)$  or for all  $x \leq z \leq y$ ,  $f(z) \leq f(x) + s(z - x)$ . We set  $g(z) = f(z) - s(z - x)$ . Thus either the map  $g$  or the map  $-g$  is an excursion of length  $l$  in the sense of the definition 6.1. Then Lemma 6.10 gives the existence of a sub-excursion of length  $l'$  satisfying  $\frac{l}{2} \leq l' < l$ , which is exactly saying that there exists  $x' < y'$  such that  $\frac{l}{2} \leq |x' - y'| < l$  and  $f(y') - f(x') = s(y' - x')$ , hence  $|f(y') - f(x')| \leq \varepsilon|y' - x'|$ .

□

**Lemma 11.3.** *Let  $x < y$  be two reals and  $f : [x, y] \rightarrow \mathbb{R}$  a continuous map. Let  $\varepsilon > 0$  and assume that  $|f(x) - f(y)| \leq \varepsilon|x - y|$ .*

*Denote  $l = |x - y|$ . Then, for all  $0 < a < l$ , there exists two reals  $x' < y'$  such that  $x \leq x' < y' \leq y$  satisfying :*

- $\frac{a}{2} \leq |x' - y'| < a$
- $|f(x') - f(y')| \leq \varepsilon|x' - y'|$

*Proof.* Define  $L_{f,\varepsilon}$  as in Lemma 11.1 :

$$L_{f,\varepsilon} = \{l' \in [0, l] \mid \exists (x', y') \in [x, y]^2, l' = |y' - x'| \text{ and } |f(y') - f(x')| \leq \varepsilon|y' - x'|\}.$$

Then  $L_{f,\varepsilon} \cap [a, l]$  is closed (by Lemma 11.1) and non-empty (because  $l \in L_{f,\varepsilon} \cap [a, l]$ ). Denote  $l' = \min L_{f,\varepsilon} \cap [a, l]$ . By Lemma 11.2, there exists  $l'' \in L_{f,\varepsilon}$  such that  $\frac{l'}{2} \leq l'' < l'$ . Then  $l'' < a$  because  $l'' < l' = \min L_{f,\varepsilon} \cap [a, l]$  and  $l'' \geq \frac{l'}{2} \geq \frac{a}{2}$ . Hence the Lemma. □

## 11.2 End of the proof

This section is dedicated to finishing the proof of theorem 1.2, which states that a Bowditch representation is simple-stable. Pick once and for all a Bowditch representation  $\rho$ , with constants  $(C, D)$ . In the section 10, we prove the existence of a constant  $K > 0$  such that for all simple elements  $\gamma \in \mathcal{S}(S_{0,4})$ , we have the inclusion  $\tau_\rho(L_\gamma) \subset N_K(\text{Axis}(\rho(\gamma)))$ . (Recall that  $L_\gamma$  denotes the geodesic generated by  $\gamma$  in the Cayley graph of  $\mathbb{F}_3 = \pi_1(S_{0,4})$  and  $\text{Axis}(\rho(\gamma))$  the axis of the hyperbolic isometry  $\rho(\gamma)$ .) For every  $\gamma$  in  $\mathcal{S}(S_{0,4})$ , pick  $\ell_\gamma$  some geodesic joining the two attracting and repelling points of  $\rho(\gamma)$ ,  $\rho(\gamma)^+$  and  $\rho(\gamma)^-$ . Then  $\ell_\gamma \subset \text{Axis}(\rho(\gamma))$  and by Lemma 6.1, there exists a constant  $C(\delta)$  such that  $N_K(\text{Axis}(\rho(\gamma))) \subset N_{K+C(\delta)}(\ell_\gamma)$ . Then, noting  $K_\delta = K + C(\delta)$ , we obtain that for all simple word  $\gamma \in \pi_1(S_{0,4})$ , we have  $\tau_\rho(L_\gamma) \subset N_{K_\delta}(\ell_\gamma)$ .

Let us choose a projection map  $p_\gamma$  on  $\ell_\gamma$ , that is a map  $p_\gamma : X \rightarrow \ell_\gamma$  such that for all  $x \in X$ ,  $p_\gamma(x) \in \ell_\gamma$  and for all  $y \in \ell_\gamma$ , we have  $d(x, p_\gamma(x)) \leq d(x, y)$ .

Let  $o \in X$  be some basepoint. For a point  $p$  on the geodesic  $\ell_\gamma$ , we define the real  $H_\gamma(p) = \pm d(p, p_\gamma(o))$ . The sign plus or minus is determined according to which side of  $p(o)$  the point  $p$  is located on. Thus  $H_\gamma$  is an isometry between  $\ell_\gamma$  and  $\mathbb{R}$  sending  $p(o)$  to 0. We also define  $E_\gamma : L_\gamma \rightarrow \mathbb{R}$  such that for all  $x \in L_\gamma$ , we have  $E_\gamma(x) = H_\gamma(p_\gamma(\tau_\rho(x)))$ .

**Lemma 11.4.** *Let  $\gamma \in \mathcal{S}(S_{0,4})$  and  $x, y \in L_\gamma$ . Then we have :*

$$d(\tau_\rho(x), \tau_\rho(y)) - 2K_\delta \leq |E_\gamma(x) - E_\gamma(y)| \leq d(\tau_\rho(x), \tau_\rho(y)) + 2K_\delta$$

*Proof.* We have  $|E_\gamma(x) - E_\gamma(y)| = d(p_\gamma(\tau_\rho(x)), p_\gamma(\tau_\rho(y)))$ , then, by the triangle inequality :

$$\begin{aligned} |E_\gamma(x) - E_\gamma(y)| &\leq d(p_\gamma(\tau_\rho(x)), \tau_\rho(x)) + d(\tau_\rho(x), \tau_\rho(y)) + d(\tau_\rho(y), p_\gamma(\tau_\rho(y))) \\ &\leq 2K_\delta + d(\tau_\rho(x), \tau_\rho(y)) \quad \text{because } \tau_\rho(L_\gamma) \subset N_{K_\delta}(\ell_\gamma) \end{aligned}$$

and on the other hand :

$$\begin{aligned} d(\tau_\rho(x), \tau_\rho(y)) &\leq d(\tau_\rho(x), p_\gamma(\tau_\rho(x))) + d(p_\gamma(\tau_\rho(x)), p_\gamma(\tau_\rho(y))) + d(\tau_\rho(y), p_\gamma(\tau_\rho(y))) \\ &\leq 2K_\delta + |E_\gamma(x) - E_\gamma(y)| \quad \text{because } \tau_\rho(L_\gamma) \subset N_{K_\delta}(\ell_\gamma) \end{aligned}$$

□

Note that  $E_\gamma$  is not necessarily continuous. (This comes from the fact that the projection map  $p_\gamma$  is itself not necessarily continuous. Indeed, such a projection may not be unique). Since we will need to use the results of the previous section on continuous map (and in particular Lemma 11.3), we are going to consider a continuous approximation of  $E_\gamma$ . Thus we define  $\tilde{E}_\gamma$  to be the map from the Cayley geodesic  $L_\gamma$  to  $\mathbb{R}$  such that, on every integer point  $x \in L_\gamma$ ,  $\tilde{E}_\gamma(x) = E_\gamma(x)$  and between two integer points, we do a linear interpolation, that is :  $\tilde{E}_\gamma(x) = tE_\gamma(\lfloor x \rfloor) + (1-t)E_\gamma(\lceil x \rceil)$ , with  $t \in [0, 1]$  such that  $d(\lfloor x \rfloor, x) = 1-t$  and  $d(\lceil x \rceil, x) = t$ . The map  $\tilde{E}$  is continuous. The next Lemma aims to compare  $E_\gamma$  and  $\tilde{E}_\gamma$ .

**Lemma 11.5.** *For all  $x, y \in L_\gamma$ , we have :*

$$|E_\gamma(x) - E_\gamma(y)| - (4C' + 8K_\delta) \leq |\tilde{E}_\gamma(x) - \tilde{E}_\gamma(y)| \leq |E_\gamma(x) - E_\gamma(y)| + 4C' + 8K_\delta$$

*Proof.* • We first prove that for all  $x \in L_\gamma$  :

$$|E_\gamma(x) - E_\gamma(\lfloor x \rfloor)| \leq C' + 2K_\delta \tag{11.1}$$

Indeed, by Lemma 11.4, we have  $|E_\gamma(x) - E_\gamma(\lfloor x \rfloor)| \leq d(\tau_\rho(x), \tau_\rho(\lfloor x \rfloor)) + 2K_\delta$ . But  $d(x, \lfloor x \rfloor) \leq 1$  and  $\tau_\rho$  is  $C'$ -Lipschitz, hence the inequality is true.

• We secondly prove that for all  $x \in L_\gamma$  :

$$|\tilde{E}_\gamma(x) - \tilde{E}_\gamma(\lfloor x \rfloor)| \leq C' + 2K_\delta \tag{11.2}$$

Indeed :

$$\begin{aligned} |\tilde{E}_\gamma(x) - \tilde{E}_\gamma(\lfloor x \rfloor)| &= |tE_\gamma(\lfloor x \rfloor) + (1-t)E_\gamma(\lceil x \rceil) - E_\gamma(\lfloor x \rfloor)| \text{ by definition of } \tilde{E}_\gamma \\ &= |1-t| |E_\gamma(\lfloor x \rfloor) - E_\gamma(\lceil x \rceil)| \\ &\leq d(\tau_\rho(\lfloor x \rfloor), \tau_\rho(\lceil x \rceil)) + 2K_\delta \quad \text{by Lemma 11.4} \\ &\leq C' + 2K_\delta \quad \text{because } d(\lfloor x \rfloor, \lceil x \rceil) \leq 1 \end{aligned}$$

- We deduce that for all  $x, y \in L_\gamma$ , we have :

$$|E_\gamma(\lfloor x \rfloor) - E_\gamma(\lfloor y \rfloor)| - (2C' + 4K_\delta) \leq |E_\gamma(x) - E_\gamma(y)| \leq 2C' + 4K_\delta + |E_\gamma(\lfloor x \rfloor) - E_\gamma(\lfloor y \rfloor)| \quad (11.3)$$

Indeed, by the triangle inequality we have :

$$\begin{aligned} |E_\gamma(x) - E_\gamma(y)| &\leq |E_\gamma(x) - E_\gamma(\lfloor x \rfloor)| + |E_\gamma(\lfloor x \rfloor) - E_\gamma(\lfloor y \rfloor)| + |E_\gamma(\lfloor y \rfloor) - E_\gamma(y)| \\ &\leq 2C' + 4K_\delta + |E_\gamma(\lfloor x \rfloor) - E_\gamma(\lfloor y \rfloor)| \text{ by (11.1)} \end{aligned}$$

and on the other hand

$$\begin{aligned} |E_\gamma(\lfloor x \rfloor) - E_\gamma(\lfloor y \rfloor)| &\leq |E_\gamma(x) - E_\gamma(\lfloor x \rfloor)| + |E_\gamma(x) - E_\gamma(y)| + |E_\gamma(\lfloor y \rfloor) - E_\gamma(y)| \\ &\leq 2C' + 4K_\delta + |E_\gamma(x) - E_\gamma(y)| \quad \text{again by 11.1} \end{aligned}$$

- Similarly, we deduce using (11.2) and the fact that  $\tilde{E}_\gamma(\lfloor x \rfloor) = E_\gamma(\lfloor x \rfloor)$ ,  $\tilde{E}_\gamma(\lfloor y \rfloor) = E_\gamma(\lfloor y \rfloor)$ , that for all  $x, y \in L_\gamma$ , we have :

$$|E_\gamma(\lfloor x \rfloor) - E_\gamma(\lfloor y \rfloor)| - (2C' + 4K_\delta) \leq |\tilde{E}_\gamma(x) - \tilde{E}_\gamma(y)| \leq 2C' + 4K_\delta + |E_\gamma(\lfloor x \rfloor) - E_\gamma(\lfloor y \rfloor)| \quad (11.4)$$

- Finally, the desired inequality follows from (11.3) and (11.4)

□

Let us now prove that  $\rho$  is simple-stable. By contradiction, suppose that it is not. Then for all  $n \in \mathbb{N}$ , we can find a simple element  $\gamma_n \in \mathcal{S}(S_{0,4})$  together with two integer points  $x_n$  and  $y_n$  on  $L_{\gamma_n}$  such that

$$d(\tau_\rho(x_n), \tau_\rho(y_n)) \leq \frac{1}{n}d(x_n, y_n) - 1 \quad (11.5)$$

In particular, we have that  $d(x_n, y_n) \geq n$ . We can make the assumption that the elements  $\gamma_n$  are pairwise distinct. Indeed, if the sequence  $(\gamma_n)_n$  only takes finitely many values, then, up to subsequence, we can suppose that  $\gamma_n = \gamma$  for some simple word  $\gamma$ . But  $\rho(\gamma)$  is a hyperbolic isometry so there exist two constants  $C_\gamma$  and  $D_\gamma$  (depending on  $\gamma$  !) such that  $\tau_\rho(L_\gamma)$  is a  $(C_\gamma, D_\gamma)$ -quasi-geodesic. Then, since  $x_n$  and  $y_n$  belong to  $L_\gamma$ , we have :

$$\begin{aligned} \frac{1}{C_\gamma}d(x_n, y_n) - D_\gamma &\leq d(\rho(x_n)o, \rho(y_n)o) \leq \frac{1}{n}d(x_n, y_n) - 1 \\ \text{so} \quad \frac{1}{C_\gamma} - \frac{D_\gamma}{d(x_n, y_n)} &\leq \frac{1}{n} - \frac{1}{d(x_n, y_n)}, \end{aligned}$$

then, taking the limit when  $n \rightarrow \infty$ ,  $\frac{1}{C_\gamma} \leq 0$ , which is absurd.

Thus we can suppose that the elements  $\gamma_n$  are pairwise distinct and therefore  $|\gamma_n| \rightarrow \infty$ . Denote by  $[N_1(\gamma_n), \dots, N_r(\gamma_n)(\gamma_n)]$  the continued fraction expansion of the slope of  $\gamma_n$ . As in the proof of the previous section (10), we can prove the following lemma.

**Lemma 11.6.** *For all  $i \in \mathbb{N}^*$ , there exists a constant  $C_i > 0$  such that for all  $n \in \mathbb{N}^*$ , whenever  $N_i(\gamma_n)$  is well defined (that is  $r(\gamma_n) \geq i$ ), we have  $N_i(\gamma_n) \leq C_i$ . Moreover, up to subsequence,  $r(\gamma_n) \rightarrow \infty$ .*

*Proof.* The proof is the same as the proof of Lemma 10.2, and the contradiction is this time on inequality 11.5 (in both Lemmas, the sequence  $(\gamma_n)_{n \in \mathbb{N}}$  is chosen in order to contradict simple-stability).  $\square$

As in section 10.2, we deduce for all integer  $i$  the existence of constants  $L_i > 0$  such that :

$$\forall n \in \mathbb{N}, \forall 0 \leq i \leq r(n), \quad i \leq l_i(\gamma_n) \leq L_i \quad (11.6)$$

Then, as in the proof of the existence of uniform tubular neighbourhoods (Proposition 10.1), we are able to find a lot of quasi-loops inside a sufficiently large subword of  $\gamma$  :

**Lemma 11.7.** *Let  $\beta = \frac{1}{168} (= \frac{\alpha}{8}$ , where  $\alpha$  is the constant introduced in Proposition 8.16).*

*Let  $0 < \varepsilon < \frac{1}{C}$  and  $r > 0$ . There exists a constant  $R > 0$  and an integer  $n_0 \in \mathbb{N}$ , such that, given any integer  $n \geq n_0$  and any subword  $u$  of  $\gamma_n$  such that  $|u| \geq R$ , there exists a positive integer  $q \in \mathbb{N}^*$ , a subset  $QL \subset \{1, \dots, q\}$  and  $q$  words  $u_1, \dots, u_q \in \mathbb{F}_2$  such that :*

1.  $u = u_1 \cdots u_q$
2. For all  $k \in QL$ ,  $u_k$  is an  $\varepsilon$ -quasi-loop
3.  $\sum_{k \in QL} |u_k| \geq \beta |u|$
4. For all  $k \notin QL$ ,  $|u_k| \geq r$

The proof of this lemma is similar to the proof of Lemma 10.6, except that in this context we find quasi-loops directly using our hypothesis on the sequence  $(\gamma_n)_{n \in \mathbb{N}}$  (equation (11.5)), and that this time we need to consider the map  $E_{\gamma_n}$  and its continuous approximation  $\tilde{E}_{\gamma_n}$  to control the length of the quasi-loops we consider.

*Proof.* We start by fixing an integer  $i$  such that  $i \geq \max(10, 2r + 7)$ . Then, we choose an integer  $n_0$  satisfying  $n_0 \geq \max\left(\frac{4}{\varepsilon}, \frac{8K_\delta}{\varepsilon}, \frac{2}{\varepsilon}(6C' + 10K_\delta) + 2, L_i\right)$  (recall that the constant  $L_i$  are defined in 11.6). Finally, let  $R \geq \max\left(\frac{3L_i}{\alpha}, 9L_i\right)$ .

Now we fix  $n \geq n_0$  and  $u$  a subword of  $\gamma_n$  such that  $|u| \geq R$ .

The first step is to find an  $\varepsilon$ -quasi-loop of length comprise between  $\frac{l_i(\gamma_n) - 7}{2}$  and  $l_i(\gamma_n) - 5$ . First observe that, by (11.5), and since  $n \geq n_0 \geq \frac{4}{\varepsilon}$ , we have :

$$d(\rho(x_n)o, \rho(y_n)o) \leq \frac{\varepsilon}{4} d(x_n, y_n) \quad (11.7)$$

so we deduce that :

$$\begin{aligned} |E_{\gamma_n}(x_n) - E_{\gamma_n}(y_n)| &\leq 2K_\delta + d(\rho(x_n)o, \rho(y_n)o) && \text{by inequality (11.4)} \\ &\leq 2K_\delta + \frac{\varepsilon}{4}d(x_n, y_n) && \text{by inequality (11.7)} \end{aligned}$$

but on another hand we have

$$d(x_n, y_n) \geq n \geq n_0 \geq \frac{8K_\delta}{\varepsilon} \quad \text{by our initial choice on } n_0,$$

$$\text{hence} \quad |E_{\gamma_n}(x_n) - E_{\gamma_n}(y_n)| \leq \frac{\varepsilon}{2}d(x_n, y_n).$$

Recall that  $x_n$  and  $y_n$  were taken to be integer points in  $L_{\gamma_n}$ . So  $\tilde{E}_{\gamma_n}(x_n) = E_{\gamma_n}(x_n)$  and  $\tilde{E}_{\gamma_n}(y_n) = E_{\gamma_n}(y_n)$ , therefore :

$$|\tilde{E}_{\gamma_n}(x_n) - \tilde{E}_{\gamma_n}(y_n)| \leq \frac{\varepsilon}{2}d(x_n, y_n).$$

Now notice that we have :

$$0 < l_i(\gamma_n) - 5 \leq L_i - 5 < n_0 \leq n \leq d(x_n, y_n)$$

so, by continuity of  $\tilde{E}_{\gamma_n}$ , we can use Lemma 11.3 to find  $x'_n, y'_n \in L_{\gamma_n}$  such that the two following hold :

$$\frac{l_i(\gamma_n) - 5}{2} \leq d(x'_n, y'_n) < l_i(\gamma_n) - 5 \quad (11.8)$$

$$|\tilde{E}_{\gamma_n}(x'_n) - \tilde{E}_{\gamma_n}(y'_n)| \leq \frac{\varepsilon}{2}d(x'_n, y'_n) \quad (11.9)$$

Now let  $v = [x'_n]^{-1}[y'_n]$ .

Let us show that  $v$  is an  $\varepsilon$ -quasi-loop.

$$\begin{aligned} d(\rho(v)o, o) &= d(\rho([x'_n])o, \rho([y'_n])o) && \text{by definition of } v \\ &\leq 2C' + d(\rho(x'_n)o, \rho(y'_n)o) && \text{since } d(x'_n, [x'_n]) < 1, d(y'_n, [y'_n]) < 1 \\ &\leq 2C' + 2K_\delta + |E_{\gamma_n}(x'_n) - E_{\gamma_n}(y'_n)| && \text{by inequality (11.4)} \\ &\leq 2C' + 2K_\delta + |\tilde{E}_{\gamma_n}(x'_n) - \tilde{E}_{\gamma_n}(y'_n)| + 4C' + 8K_\delta && \text{by Lemma (11.5)} \\ &\leq 6C' + 10K_\delta + \frac{\varepsilon}{2}d(x'_n, y'_n) && \text{by (11.9)} \\ &\leq 6C' + 10K_\delta + \frac{\varepsilon}{2}(|v| + 1) \\ &\leq 6C' + 10K_\delta + \frac{\varepsilon}{2} + \frac{\varepsilon}{2}|v| \end{aligned}$$

but on an other hand, since  $n_0 \geq \frac{2}{\varepsilon}(6C' + 10K_\delta) + 2$ , we have

$$|v| = d([x'_n], [y'_n]) \geq d(x'_n, y'_n) - 1 \geq n - 1 \geq n_0 - 1 \geq \frac{2}{\varepsilon}(6C' + 10K_\delta) + 1$$

and then  $d(\rho(v)o, o) \leq \varepsilon|v|$ ,

which ensures that  $v$  is an  $\varepsilon$ -quasi-loop.

Note that we have the following inequality on the length of  $v$  :

$$\begin{aligned} & d(x'_n, y'_n) - 1 < |v| < d(x'_n, y'_n) + 1 \\ \text{so} \quad & \frac{l_i(\gamma_n) - 7}{2} < |v| < l_i(\gamma_n) - 4 \quad \text{by (11.8)} \\ \text{then} \quad & \frac{l_i(\gamma_n) - 7}{2} \leq |v| \leq l_i(\gamma_n) - 5 \quad \text{since } |v| \text{ is an integer} \end{aligned}$$

The rest of the proof is exactly the same as for Lemma 10.6. We consider  $w$  the subword of  $\gamma_n$  of length  $l_i(\gamma_n) - 5$  such that  $v$  is a prefix of  $w$ . Then we can apply Proposition 8.16 to  $u$  and  $w$  (since we have imposed  $R \geq 9L_i$ ) and we verify the four points of Lemma 11.7. Indeed :

1. comes directly from Lemma 8.16.
2. is true since we proved that  $v$  is an  $\varepsilon$ -quasi-loop.
3. is true since we fixed  $R$  such that  $R \geq \frac{3L_i}{\alpha}$ .
4. is true since we fixed  $i$  such that  $i \geq 2r + 7$ .

□

Once we have Lemma 11.7, the procedure for the end of the proof of simple-stability is the same as for Proposition 10.1.

For completeness, we recall the last steps.

We are now able to find a simple element  $\gamma$  (from the sequence  $(\gamma_n)_{n \in \mathbb{N}}$ ) which contains a very large proportion of quasi-loops.

**Lemma 11.8.** *Let  $0 < \varepsilon < \frac{1}{C}$  and  $1 - \frac{1}{C'}(\frac{1}{C} - \varepsilon) < \lambda < 1$ . There exists a simple element  $\gamma$  such that  $\gamma$  contains  $\varepsilon$ -quasi-loops that occupy at least a proportion  $\lambda$  of  $\gamma$ .*

*Proof.* The proof is the same as the proof of Lemma 6.18, using Lemma 11.7 instead of Lemma 6.17. □

Then we show that if such an element exists, we obtain an inequality on the displacement of the basepoint  $o$ .

**Lemma 11.9.** *Let  $0 < \varepsilon < \frac{1}{C}$  and  $1 - \frac{1}{C'}(\frac{1}{C} - \varepsilon) < \lambda < 1$ . Let  $\gamma$  be a simple word of  $\pi_1(S_{0,4})$  which contains  $\varepsilon$ -quasi-loops which occupy at least a proportion  $\lambda$  of  $\gamma$ . Then*

$$d(\rho(\gamma)o, o) < \frac{1}{C}|\gamma|.$$

*Proof.* The proof is the same as in the proof of Lemma 6.19. □

And thus this inequality contradicts the Bowditch hypothesis, so we found a contradiction and then Theorem 1.4 is proved.





# Bibliography

- [Bow98] B.H. Bowditch. “Markoff triples and quasifuchsian groups”. en. In: *Proceedings of the London Mathematical Society* 77.3 (Nov. 1998), pp. 697–736.
- [Can15] Richard D Canary. “Dynamics on character varieties: a survey”. en. In: *Handbook of Group Actions* Vol. II (2015), pp. 175–200.
- [CDP90] Michel Coornaert, Thomas Delzant, and Athanase Papadopoulos. *Géométrie et théorie des groupes*. Vol. 1441. Lecture Notes in Mathematics. Berlin, Heidelberg: Springer, 1990.
- [Del+11] Thomas Delzant, Olivier Guichard, Francois Labourie, and Shahar Mozes. “Displacing representations and orbit maps”. en. In: *Geometry, rigidity and group actions* Univ. Chicago Press (2011), pp. 494–514.
- [FM12] Benson Farb and Dan Margalit. *A primer on mapping class groups*. en. Princeton mathematical series. Princeton, NJ: Princeton University Press, 2012.
- [GK11] Jane Gilman and Linda Keen. “Enumerating palindromes and primitives in rank two free groups”. en. In: *Journal of Algebra* 332.1 (Apr. 2011), pp. 1–13.
- [Gol88] William M. Goldman. “Topological components of spaces of representations”. en. In: *Inventiones Mathematicae* 93.3 (Oct. 1988), pp. 557–607.
- [Kna96] Anthony W. Kna. *Lie Groups Beyond an Introduction*. en. Boston, MA: Birkhäuser Boston, 1996.
- [LX19] Jaejeong Lee and Binbin Xu. “Bowditch’s Q-conditions and Minsky’s primitive stability”. en. In: *Transactions of the American Mathematical Society* 373.2 (Oct. 2019), pp. 1265–1305.
- [MP20] Sara Maloni and Frédéric Palesi. “On the character variety of the three-holed projective plane”. en. In: *Conformal Geometry and Dynamics of the American Mathematical Society* 24.4 (Mar. 2020), pp. 68–108.
- [MPT15] Sara Maloni, Frédéric Palesi, and Ser Peow Tan. “On the character variety of the four-holed sphere”. en. In: *Groups, Geometry, and Dynamics* 9.3 (2015), pp. 737–782.
- [MPY21] Sara Maloni, Frédéric Palesi, and Tian Yang. “On type-preserving representations of thrice punctured projective plane group”. In: *Journal of Differential Geometry* 119.3 (Nov. 2021), pp. 421–457.

- [Min13] Yair N. Minsky. “On dynamics of  $\text{Out}(F_n)$  on  $\text{PSL}(2, \mathbb{C})$  characters”. en. In: *Israel J. Math.* 193 (2013), pp. 47–70.
- [Nie18] J. Nielsen. “Über die Isomorphismen unendlicher Gruppen ohne Relation”. de. In: *Mathematische Annalen* 79.3 (Sept. 1918), pp. 269–272.
- [Nie24] Jakob Nielsen. “Die Isomorphismengruppe der freien Gruppen”. de. In: *Mathematische Annalen* 91.3-4 (Sept. 1924), pp. 169–209.
- [Pal14] Frédéric Palesi. “Dynamique de l’action du groupe modulaire et triplets de Markov”. fr. In: *Séminaire de théorie spectrale et géométrie* 31 (2014), pp. 137–161.
- [Ser85] Caroline Series. “The geometry of markoff numbers”. en. In: *The Mathematical Intelligencer* 7.3 (Sept. 1985), pp. 20–29.
- [Ser19] Caroline Series. “Primitive stability and Bowditch’s BQ-condition are equivalent”. en. In: *arXiv:1901.01396 [math]* (Jan. 2019).
- [Ser20] Caroline Series. “Primitive stability and the Bowditch conditions revisited”. en. In: *arXiv:2006.10403 [math]* (June 2020).
- [TWZ08] Ser Peow Tan, Yan Loi Wong, and Ying Zhang. “Generalized Markoff maps and McShane’s identity”. en. In: *Advances in Mathematics* 217.2 (Jan. 2008), pp. 761–813.