



HAL
open science

Prise en compte de la dimension temporelle dans l'évaluation environnementale des produits de la biomasse Modélisation dynamique du carbone

Ariane Christine Albers

► **To cite this version:**

Ariane Christine Albers. Prise en compte de la dimension temporelle dans l'évaluation environnementale des produits de la biomasse Modélisation dynamique du carbone. Ingénierie de l'environnement. Montpellier SupAgro, 2019. Français. NNT : 2019NSAM0048 . tel-04430764

HAL Id: tel-04430764

<https://theses.hal.science/tel-04430764>

Submitted on 1 Feb 2024

HAL is a multi-disciplinary open access archive for the deposit and dissemination of scientific research documents, whether they are published or not. The documents may come from teaching and research institutions in France or abroad, or from public or private research centers.

L'archive ouverte pluridisciplinaire **HAL**, est destinée au dépôt et à la diffusion de documents scientifiques de niveau recherche, publiés ou non, émanant des établissements d'enseignement et de recherche français ou étrangers, des laboratoires publics ou privés.

THÈSE POUR OBTENIR LE GRADE DE DOCTEUR DE MONTPELLIER SUPAGRO

En génie des procédés

École doctorale GAIA – Biodiversité, Agriculture, Alimentation, Environnement, Terre, Eau
Portée par l'Université de Montpellier

Unité de recherche INRA – Laboratoire de Biotechnologie de l'Environnement

Prise en compte de la dimension temporelle dans l'évaluation environnementale des produits de la biomasse : Modélisation dynamique du carbone

Présentée par Ariane ALBERS

Le 16 Déc. 2019

Sous la direction d'Arnaud HELIAS

et co-encadrement de Pierre COLLET et Anthony BENOIST

Devant le jury composé de

Arnaud HÉLIAS, Directeur d'Unité, INRAE UMR ITAP, France
Tewfik SARI, Directeur de Recherche, INRAE UMR ITAP, France
Assumpció ANTON, Directrice de Recherche, IRTA, Espagne
Miguel BRANDAO, Assistant Professeur, KTH Université, Suède
Ligia TIRUTA-BARNA, Professeur, INSA Toulouse, France
Chantal LE MOUËL, Directrice de Recherche, INRA, France
Annie LEVASSEUR, Professeur, ETS Université du Québec, Canada
Pierre COLLET, Ingénieur de Recherche, IFPEN, France
Anthony BENOIST, Chercheur, CIRAD, France

Directeur de thèse/ Représentant ED
Président du jury
Rapportrice
Rapporteur
Examinatrice
Examinatrice
Membre invité
Encadrant
Encadrant



UNIVERSITÉ
DE MONTPELLIER



A caballo en el campo

Y de pronto, detente:

¡El ruiseñor!

(Matsuo Bashō – Sendas de Oku)

My sincere gratitude is dedicated to IFPEN
for financing and opening the opportunity for this research.



A special thanks to IFPEN **Division of Economics & Technology Intelligence** and the **IFP Doctoral School**, in collaboration with the ELSA Group, INRA-LBE, CIRAD and Solvay.

Acknowledgements

I wish to thank everyone who has crossed my path along this journey, who has contributed to this endeavour in many ways, professionally and personally. The warm welcome from colleagues in Paris and Montpellier, the discussions during internal seminars and workshops, every smile, breakfast on Tuesday, and much more.

First of all, I would like to thank my direction and supervision, the composition of an enthusiastic *trio*, who has accompanied me from the beginning to the end with their passion for the topic, guiding me patiently through the challenges, in good and bad times, always up to intensive discussions and useful critique of this research. During these three years I have learned a lot, for which I am very grateful. I would like to express my sincere appreciation to each one individually. Dr Arnaud Hélias (Research director, ITAP) thank you for your visionary mind, patience and love for drawing. Dr Anthony Benoist (Researcher, CIRAD) thank you for your sense of detail, your eagle eye and devotion. Dr Pierre Collet (Environmental Engineer, IFPEN), thank you for sense of humour, optimism and quick actions.

I would like to offer my special thanks to everyone I worked with and who contributed to this research work. Thanks to Dr Daphné Lorne (Economist Engineer, IFPEN) and Dr Jean-Francois Viot (Senior Principal Scientist, SOLVAY) for your technical support and rapid response to any enquiries. My gratitude also goes to Dr Cécile Bessou (Researcher CIRAD) for her dedication and technical support.

Also, I would like to express my gratitude to the members of the two thesis committees: Dr Valérie Guillard (Associate Professor, Université de Montpellier), Dr Eric Trably (Research Director, LBE), Dr Annie Levasseur (Professor, ETS) and Dr

Nicolas Bernet (Research Director, LBE), for their interest in this research and constructive critiques. I would like to take this occasion and thank particularly Annie, for being an inspiration for this work, her devotion and kindness.

Moreover, I would like to extend my sincere appreciation to all jury members of the thesis defence, Dr Tewfik Sari, Dr Miguel Brandão, Dr Ligia Tiruta-Barna, Dr Assumpció Antón, Dr Chantal le Mouël, Dr Annie Levasseur, including my direction and co-supervision, for taking their time to critically review this dissertation, bringing up discussions points, highlighting some limitations and contributing to improving the final conclusions.

I wish to thank various colleagues from IFPEN and ELSA Group, for their contributions and friendship along the way. To all my office mates and PhD fellows: Susana Leão, Mattia Damiani, Antoine Esnouf, Charlotte Pradinaud, Gustave Coste, Jean Hercher Pasteur and Maria-José Rodriguez Vasquez. To my next door mates: Eva Rich, Melissa Cornelus, Eleonore Loiseau and Philippe Roux. Thank you for the exchanges and bringing me closer to French traditions and culture, sharing the love for wine and la brassucade de moules. Merci! Not to forget, Montserrat Nuñez and Ralph Rosenbaum, thank you for all the long conversations in the name of positivism and quality time.

A special thanks also to Dr Sylvie Manguin (Research director, IRD) for embracing me in her tutorship in the programme Women in Science.

Finally, I would like to thank my family and friends for their encouragement and support along this milestone. To my Hasi for believing and endlessly reinforcing me, and pushing me always a step forward. And to Attila the Destroyer for calming my horses.

Thank you!

Declaration

I hereby declare that the dissertation entitled, “Consideration of the time dimension in the environmental assessment of biomass products: Dynamic carbon modelling”, was written and submitted by me to Montpellier SupAgro, in fulfilment of the requirements to obtain the degree of Doctor of Philosophy.

I further declare that I am the sole author of this thesis and to the best of my knowledge it contains no materials previously published or written by another person, which could infringe upon anyone’s copyright or violate any property rights. All information in this document was obtained and presented in accordance with academic rules and ethical conduct. All material and results that are not original to this work are cited in consistency with the standard referencing practices, as required by academic rules.

I also certify that neither any part of this thesis nor the whole of the thesis was submitted for a degree to any other university.

Ariane Albers
Montpellier, 16 December, 2019

Abstract

Low carbon strategies promote the use of renewable energy carriers and biomaterials originating, *inter alia*, from dedicated and residual forestry and agricultural biomass (e.g. energy crops, woody residues), as allegedly carbon neutral options displacing/offsetting an energetically equivalent amount of fossil carbon, thus resulting in zero net CO₂ emissions. Current modelling approaches in Life Cycle Assessment (LCA) and carbon footprint methodologies are static. The life cycle inventory relies on simplified aggregation of all carbon flows from different process units, disregarding the **temporal variability of biogenic flows**, thus justifying the carbon neutrality hypothesis.

The main purpose of this work is to provide the tools to build dynamic inventories and analyse how the dynamic impact assessment results and conclusions differ from static ones. A proposed modelling framework considers: a) upstream models for non-linear biomass growth, above- and belowground biogenic carbon (C_{bio}) sequestration, soil organic carbon (SOC) dynamic associated to land uses, including management practices; and b) downstream models for case-specific end-of-life pathways, eventually delaying emissions. Moreover, the dynamic models were designed to be coupled with outputs from any demand model (e.g. technical flows specifying the amount of biomass supply/use in a studied system or bioproduct) to develop complete dynamic carbon inventories (fossil + biogenic). A partial-equilibrium model was used throughout the case studies to estimate the consequences of policy-induced changes (i.e. energy transition).

The overall results showed that modelling both C_{bio} sequestration and SOC dynamic reduced uncertainty and bias of mitigation effects. Upstream modelling is dependent on biomass type and sensitive to the timing of the first sequestration flow, rotation lengths and variations in the residue removal rates. The modelling approaches can be further refined to site- and/or case-specific settings. This dissertation thus bridges the gap between the time dimension in LCA and dynamic C_{bio} modelling, thus contributing to the improvement of the LCA methodology, towards more robust decision support in defining actions to mitigate climate change.

Keywords: life cycle assessment, dynamic modelling, biogenic carbon, forestry and agricultural biomass, climate change, time dimension.

Résumé

Les stratégies bas carbone favorisent l'utilisation de sources d'énergie renouvelable et de biomatériaux provenant, entre autres, de la biomasse forestière et agricole dédiée et résiduelle, pour atteindre la neutralité carbone, qui se traduit par une compensation entre émissions et captations de CO₂. Les approches actuelles de modélisation en analyse du cycle de vie (ACV) et pour l'empreinte carbone sont statiques, représentant les systèmes à l'état d'équilibre. L'inventaire du cycle de vie repose sur une agrégation simplifiée de tous les flux de carbone provenant de différentes unités de processus, ignorant **la variabilité temporelle des flux biosourcés**. Cela justifie l'hypothèse de neutralité carbone.

L'objectif principal de ce travail est de fournir les outils permettant de décrire des inventaires dynamiques et d'analyser en quoi les résultats et conclusions issus d'évaluations dynamiques diffèrent de ceux obtenus par les approches statiques. Le cadre de modélisation proposé tient compte : a) des modèles en amont (production), non linéaires, de la croissance de la biomasse et de la séquestration du carbone organique du sol (COS) associé à l'utilisation des terres, y compris les pratiques de gestion culturale, ainsi que b) des modèles en aval pour des options de fin de vie spécifiques (gestion des déchets et résidus), qui retardent éventuellement les émissions. Les modèles dynamiques mis en jeu ont été conçus pour être couplés aux résultats de n'importe quel modèle de demande (fournissant des flux techniques précisant la quantité de biomasses fournie/utilisée dans un système étudié) afin d'élaborer des inventaires dynamiques complets du carbone (fossiles + biogéniques). Un modèle d'équilibre partiel pour l'évaluation des scénarios prospectifs de bioénergie a été utilisé à travers des études de cas pour l'estimation des conséquences des changements induits par les politiques publiques (transition énergétique).

Les résultats globaux ont montré que la modélisation de la séquestration du carbone biogénique (C_{bio}) et de la dynamique du COS fournit une représentation plus précise des flux de C_{bio} et des effets d'atténuation. La modélisation en amont dépend du type de biomasse et est sensible au moment du premier flux de séquestration, aux longueurs de rotation des cultures et aux variations des taux d'exportation des résidus. Les approches de modélisation peuvent être affinées pour tenir compte des contextes propres à un site ou à un cas particulier. Ce travail permet donc une meilleure prise en compte du C_{bio} et contribue à l'amélioration de la méthodologie ACV. Cela est particulièrement pertinent pour la définition des actions à mettre en œuvre face au changement climatique.

Mots clés : analyse du cycle de vie, modélisation dynamique, carbone biogénique, biomasse forestière et agricole, changement climatique, dimension temporelle.

Resumen ejecutivo

Las estrategias bajas en carbono promueven el uso de fuentes de energía renovable y biomateriales que se originan, entre otros, de la biomasa forestal y agrícola dedicada y residual (ej. cultivos energéticos, residuos leñosos), como opciones supuestamente neutras en carbono que desplazan o compensan una cantidad energéticamente equivalente de carbono fósil, lo que resulta en cero emisiones netas de CO₂. Los enfoques actuales de modelización en las metodologías del análisis de ciclo de vida (ACV) y de la huella de carbono son estáticos. El inventario del ciclo de vida se basa en la agregación simplificada de todos los flujos de carbono de diferentes unidades de proceso, ignorando la **variabilidad temporal de los flujos biogénicos**, lo que justifica la hipótesis de neutralidad de carbono.

El objetivo principal de este trabajo es proporcionar las herramientas para construir inventarios dinámicos y analizar en qué se diferencian los resultados y conclusiones de las evaluaciones de impacto dinámicas y estáticas. El método de modelización propuesto considera: a) modelos de crecimiento de biomasa no lineales, secuestro aéreo y subterráneo de C_{bio}, dinámica del carbono orgánico del suelo (COS) asociada a los usos de la tierra, incluidas las prácticas de gestión; y b) modelos para trayectorias de fin de vida específicas, que retrasan eventualmente las emisiones. Además, los modelos dinámicos se diseñaron para acoplarse a los resultados de cualquier modelo de demanda (ej. flujos técnicos que especifican la cantidad de biomasa requerida por un sistema) para desarrollar inventarios de carbono dinámicos completos (fósiles + biogénicos). En todos los estudios de caso se utilizó un modelo de equilibrio parcial para elaborar inventarios C_{bio} a partir de escenarios bioenergéticos prospectivos del subsector del transporte y estimar las consecuencias de los cambios inducidos por las políticas (es decir, la transición energética).

Los resultados generales mostraron que la modelización, tanto del secuestro de C_{bio} como de la dinámica de COS, proporciona una representación más precisa de los flujos de C_{bio} y de los efectos de mitigación. La modelización aguas arriba depende del tipo de biomasa y es sensible al momento en que se produce el primer flujo de secuestro, a las longitudes de rotación y a las variaciones en las tasas de remoción de residuos. Los enfoques de modelización se pueden refinar aún más para adaptarlos a los entornos específicos de cada emplazamiento y/o caso. Esta disertación cierra así la brecha entre la dimensión temporal del ACV y la modelización dinámica de la C_{bio}, contribuyendo así a la mejora de la metodología del ACV, hacia un apoyo más sólido a la toma de decisiones en la definición de acciones para mitigar el cambio climático.

Palabras clave: análisis del ciclo de vida, modelización dinámica, carbono biogénico, biomasa forestal y agrícola, cambio climático, dimensión temporal.

Zusammenfassung

Eine CO₂-arme Entwicklung fördert die Nutzung einerseits von erneuerbaren Energieträgern und andererseits von Erzeugnissen von Produkten aus der Biomasse (beispielsweise Energiepflanzen, Resthölzer). Diese erneuerbaren Rohstoffe gelten als klimaneutrale Optionen (null CO₂-Ausstoß), wobei eine energetisch äquivalente Menge an fossilem Kohlenstoff aus Verbrennung ausgleichen wird. Die Ansätze der Ökobilanz oder Klimabilanz basieren auf einer vereinfachten Aggregation aller Treibhausgasemissionen aus verschiedenen Prozesseinheiten. Dieser CO₂ Modellierung-Ansatz ist statisch, da die Zeitdifferenzierung dynamischer Ströme, also wann eine Emission stattfindet, nicht berücksichtigt wird. Somit wird die Klimaneutralität in der Gesamtbilanz gerechtfertigt.

Die Hauptziele dieser Dissertation sind der Aufbau von dynamischen Klimabilanzen und das Erproben von Hilfsmitteln zur Analyse biogener Ströme aus Biomassenutzung. Ebenfalls sollen statische Schlussfolgerungen von dynamischen Folgenabschätzungen abgegrenzt werden. Eine vorgeschlagene Herangehensweise in dieser Arbeit berücksichtigt eine dynamische Bestandsaufnahme im Zusammenhang mit Landnutzungen in der Forst- und Agrarwirtschaft, aus: a) nichtlinearem Wachstum und CO₂ Bindung in den Pflanzen, sowie dem CO₂ Ausstoß von organischem Kohlenstoff im Boden; und b) Ausstoßemissionen mit möglicher Verzögerung durch eine lange Lebensdauer eines Produktes. Darüber hinaus, werden die dynamischen Modelle so konzipiert, dass sie mit einem beliebigen Nachfragemodell gekoppelt werden können (beispielsweise bezüglich zukünftiger Biomasseversorgung bzw. -nutzung). Infolgedessen werden vollständige dynamische Klimabilanzen aus fossilen und biogenen Kohlenstoffträgern entwickeln. In den Fallstudien wurde ein partielles Gleichgewichtsmodell verwendet, um dynamische Bilanzen aus prospektiven Bioenergieszenarien zu entwickeln und die Folgen politisch bedingter Veränderungen (z.B. Energiewende) abzuschätzen.

Das Gesamtergebnis zeigt, dass die Modellierung von folgenden Aspekten abhängig ist: die Art der Biomasse, der Zeitpunkt der ersten CO₂ Bindung, die Änderung der Rotationslänge und die Reststoffnutzung. Die Modellierungsansätze können zu standort- und/oder fallspezifischen Studien weiterentwickelt werden. Diese Dissertation schließt somit die Forschungslücke zwischen der Zeitdimension und den dynamischen biogenen Strömen. Sie trägt daher zur Verbesserung der Ökobilanzmethodik bei, eine robustere Entscheidungsunterstützung bezüglich der Definition von Maßnahmen zur Minderung des Klimawandels.

Stichworte: Ökobilanz, dynamische Modellierung, biogener Kohlenstoff, forstwirtschaftliche und landwirtschaftliche Biomasse, Klimawandel, Zeitdimension.

Résumé substantiel

Contexte

Face à la nécessité d'agir pour lutter contre le changement climatique, l'utilisation de la biomasse est au premier plan du fait de son caractère renouvelable. Les pouvoirs publics tendent de plus en plus à favoriser le remplacement du carbone (C) d'origine fossile par du carbone issu de biomasse pour une large gamme d'utilisations (bioénergie, biomatériaux et biochimie intermédiaire).

Le carbone biogénique (C_{bio}) représente le C issu de la biomasse (animale et végétale). Il est échangé avec l'atmosphère à plusieurs niveaux : absorption sous forme de CO_2 par la photosynthèse, et (ré)émission principalement sous forme de CO_2 , mais aussi de CH_4 , par des processus naturels (e.g. respiration) ou des activités humaines (e.g. combustion). Le carbone issu de biomasse morte est en grande partie incorporé dans le sol sous forme de Carbone Organique du Sol (COS), et participe aussi au cycle du carbone biogénique.

L'impact sur le changement climatique des émissions de CO_2 d'origine biogénique est le plus souvent considéré comme nul. L'hypothèse sous-jacente à cette approche est que la neutralité carbone équivaut à une neutralité climatique. Cela signifie qu'une quantité de CO_2 émise par combustion ou incinération puis (ré)séquestrée pendant la (re)pousse des plantes n'a pas d'influence sur le changement climatique, ce qui permet d'omettre le CO_2 biogénique dans l'inventaire des émissions de Gaz à Effet de Serre (GES). La plupart des approches de modélisation de carbone d'origine biogénique actuellement utilisées dans les politiques climatiques s'appuient sur cette hypothèse de neutralité climatique du carbone biogénique pour promouvoir l'utilisation et le développement de produits issus de la biomasse.

Cette neutralité a été remise en question à différentes échelles par plusieurs chercheurs, notamment en termes d'effets non nuls sur le changement climatique pour des forêts avec de longues durées de rotation. Des conclusions sous-évaluant le changement climatique ont pu être présentées amenant par exemple à des recommandations en faveur de la déforestation de forêt tropicale pour la bioénergie. Cette controverse porte en particulier sur le fait qu'il faut parfois plusieurs décennies pour (re)séquestrer le CO_2 émis par la combustion de biomasse issue de forêts.

Plusieurs chercheurs reconnaissent la nécessité de tenir compte des variations temporelles des émissions négatives (absorption lors de la photosynthèse) et positives (émissions par respiration ou combustion par exemple) de CO_2 biogénique, notamment par la prise en compte des potentiels délais entre stockage et déstockage de C_{bio} dans la biomasse, et les effets sur le changement climatique induits.

Toutefois, il n'existe pas de consensus sur la façon de modéliser ces flux dynamiques et de les intégrer dans les méthodes d'évaluation environnementale existantes comme l'Analyse de Cycle de Vie (ACV). L'ACV offre un cadre normalisé pour évaluer les impacts environnementaux potentiels lié à la fabrication d'un produit ou à la fourniture d'un service. L'approche dresse un inventaire détaillé de toutes les ressources consommées et des émissions associées à une unité fonctionnelle d'un produit tout au long de son cycle de vie.

L'ACV est également connue comme une approche du berceau à la tombe (cradle-to-grave), car l'inventaire vise à quantifier tous les flux extraits de l'environnement et réémis dans l'environnement pendant toutes les différentes étapes du cycle de vie d'un produit : extraction des matières premières, fabrication, utilisation, traitement des déchets par valorisation ou élimination finale des matériaux en fin de vie, en intégrant le transport tout au long de la chaîne d'approvisionnement.

Si la méthodologie de l'ACV aborde plusieurs indicateurs d'impact, cette thèse se focalise uniquement sur la catégorie d'impact « changement climatique », au regard des enjeux liés à la dynamique du C_{bio} . Cet impact est traditionnellement évalué avec les Potentiels de Réchauffement Global (PRG) établis par le groupe d'experts intergouvernemental sur l'évolution du climat (GIEC). L'impact alors obtenu est une mesure relative, calculée à partir de la somme pondérée par les PRG de toutes les émissions de GES (en masse). Cette agrégation ne tient pas compte de la **variabilité temporelle** des flux d'émissions. L'information temporelle est donc perdue, car il n'est pas précisé quand les émissions ont eu lieu. Cette approche statique se heurte à deux grandes limites :

- Les flux biogéniques de séquestration et d'émission s'annulent, justifiant ainsi l'hypothèse de la neutralité climatique du carbone biogénique. Mais cela ne permet pas de prendre en compte l'effet sur le bilan GES des variations temporelles.
- L'application d'un horizon temporel fixe pour calculer le bilan GES, et donc une inconsistance temporelle possible entre l'horizon temporel couvert par l'inventaire et celui couvert par l'impact évalué.

La temporalité des flux de carbone biogénique, y compris les délais d'émission de carbone consécutifs à une immobilisation du carbone dans des produits à longue durée de vie, peut varier considérablement, ce qui constitue une source essentielle d'incertitude dans les résultats statiques.

Les objectifs de thèse

Cette thèse contribue à associer la dimension temporelle en ACV et la modélisation dynamique du C_{bio} des produits provenant de la biomasse.

L'objectif principal de cette thèse est donc de fournir les outils permettant de décrire des inventaires dynamiques et d'analyser comment les résultats ainsi calculés diffèrent de ceux obtenus par les approches statiques.

Le cadre de modélisation proposé tient compte :

- des modèles en amont (production), non linéaires, de la croissance de la biomasse, de la séquestration du CO₂ associé à l'utilisation et la gestion des terres, ainsi que
- des modèles en aval pour des voies de fin de vie spécifique (gestion des déchets et résidus), qui retardent éventuellement les (ré)émissions de carbone biogénique dans l'atmosphère.

Approche

Cette thèse s'inscrit dans un contexte pluridisciplinaire (écologie, sylviculture, agriculture, économie et sciences environnementales) afin d'évaluer les conséquences du changement climatique de produits issus de la biomasse, en combinant un cadre d'ACV dynamique et la modélisation de la mise en œuvre des politiques climatiques.

La structure des chapitres (sept au total) est organisée pour que l'état de l'art mette en lumière les approches existantes et les enjeux de la recherche par rapport à celles-ci. Celui-ci permet de définir le cadre de modélisation qui est mise en œuvre sur des études de cas. L'applicabilité et les limites sont ensuite discutées.

Cette thèse est construite sur trois articles acceptés (en tant qu'auteur principal), et deux articles en cours de soumission (un article de revue en tant que co-auteur, et un article en tant qu'auteur principal). Les spécifications des données de la modélisation sont présentées en annexes, dont l'une a été valorisée sous forme d'un data paper accepté (en tant qu'auteur principal).

Le chapitre 1 présente brièvement le contexte, les objectifs et la stratégie de recherche.

Le chapitre 2 présente les fondements théoriques de ce travail. Il expose les principes de l'évaluation du changement climatique et de l'ACV. Il met en avant les limites, les implications temporelles et les méthodes actuellement proposées pour évaluer les flux dynamiques du carbone. Cela permet de définir les bases nécessaires à la modélisation du C_{bio} en ACV.

Le chapitre 3 décrit en détail le cadre de modélisation dynamique proposé. Celui-ci est aligné sur les grandes étapes de l'ACV, avec un accent particulier sur la phase d'inventaire du cycle de vie. Une étude détaillée sur un produit de bois d'œuvre est incluse à titre d'exemple. Ce cadre décrit en chapitre 3 est ensuite utilisé dans deux études de cas, au chapitre 4 (secteur forestier) et au chapitre 5 (secteur agricole),

Le chapitre 4 est consacré à la modélisation dynamique des systèmes forestiers. La séquestration du carbone dans la biomasse est quantifiée par des modèles dynamiques de croissance et de relations allométriques. Ce travail se prolonge par l'analyse des différentes perspectives temporelles de modélisation et de leurs implications pour l'ACV.

Le chapitre 5 porte sur les systèmes agricoles. Il s'intéresse à la modélisation dynamique du carbone organique du sol, provenant de la biomasse résiduelle de cultures énergétiques, annuelles et pérennes. Ceci est abordé à travers la productivité primaire nette et la répartition du carbone dans les différents organes de la plante. Avec des profils de séquestration à court terme et d'émission de CO₂ associés au sol, la modélisation des productions en est ainsi améliorée.

Le chapitre 6 présente une synthèse et une discussion des principaux résultats en identifiant les difficultés de mise en œuvre, les incertitudes et les limites.

Le chapitre 7 termine cette thèse par un bilan et fournit les orientations et les perspectives pour la poursuite de ces travaux.

Modélisation dynamique et ACV

Ce travail contribue, sur la base des connaissances actuelles, au développement méthodologique de l'ACV dynamique. Il existe déjà une méthode d'ACV dynamique pour la catégorie d'impact du changement climatique. Cette méthode, construite à partir d'inventaires des émissions de GES différenciés annuellement, permet l'évaluation de l'impact en fonction du temps, avec des horizons temporels flexibles. Même si définir un horizon temporel est inévitable, il permet de tester la sensibilité des différents choix et leurs conséquences sur les résultats.

Il est donc nécessaire de disposer d'un inventaire dynamique pour obtenir un impact en fonction du temps. Ceci implique la prise en compte de flux de carbone non agrégés issus de la biomasse dans l'étape de l'inventaire. Il faut alors tenir compte de profils d'émissions temporels (flux de stockage et déstockage) à toutes les étapes du cycle de vie. L'objectif est donc le développement de bilans carbone complets et dynamiques (impliquant du carbone fossile et biogénique), et de mettre en évidence les éléments clés dépendant du temps.

Le calcul des flux dynamiques de carbone biogénique avec l'environnement peut être couplé à n'importe quel modèle de demande (flux techniques de biens et de services). Cela peut être fait pour des scénarios (prédictifs, exploratoires ou normatifs) basés sur les flux socio-économiques :

- Évolution des marchés, innovation technologique et parcours/filières énergétiques prospectifs ;
- Analyse des politiques climat-énergie et stratégies d'atténuation pluriannuelles envisagées ;
- Différenciation spatio-temporelle des productions ;
- Externalités et données marginales

Dans cette thèse, le modèle d'équilibre partiel TIMES MIRET a été utilisé dans les études de cas pour développer des inventaires C_{bio} à partir de scénarios prospectifs relatifs au secteur énergétique français. Des focus ont été réalisés sur différents sous-secteurs liés aux bioénergies (biocarburants pour le transport, ou biomasse pour la chaleur et l'électricité par exemple). Ceci permet d'estimer les implications des politiques publiques en termes d'impact sur le changement climatique (comme la loi relative à la transition énergétique pour la croissance verte dans un contexte français).

Les matières premières comprennent deux grandes catégories de biomasse :

- i. Issue de cultures dédiées : cultures amylicées (blé, maïs), cultures sucrières (betterave sucrière), graines oléagineuses (colza, tournesol), biomasse lignocellulosique (miscanthus, switchgrass, peuplier, saule, bois des forêts) et algues. L'ensemble de ces ressources est résumé sous les termes génériques suivants : cultures annuelles, cultures pérennes, et biomasses aquatiques.
- ii. Résiduelle : résidus lignocellulosiques (par exemple rémanents forestiers, autres résidus ligneux), résidus herbacés et agricoles, et résidus agro-industriels.

La modélisation de la séquestration du C_{bio} est liée à la modélisation de la croissance des plantes. Des approches dynamiques de la croissance sont utilisées ici pour prédire le développement des plantes, et leur rendement potentiel. Les paramètres sont ajustés à l'aide de régressions non linéaires à partir de tables de rendement. Cette approche est complétée par des relations allométriques pour pouvoir quantifier les dynamiques de croissance des arbres forestiers (i.e. les liens entre la croissance en âge et en taille des plantes).

La modélisation du COS renvoie au C ajouté au sol à partir de différentes fractions de cultures considérées par unité de surface en fonction des scénarios d'occupation du sol. Si la neutralité carbone peut s'appliquer aux produits végétaux exportés et rapidement utilisés (par exemple, la betterave sucrière pour la production de bioéthanol), d'autres parties de la plante restent à la parcelle et contribuent au renouvellement voire à l'accumulation de la matière organique du sol.

Ce travail est basé sur un modèle du COS de la littérature à deux compartiments qui analyse : i) les apports de matière organique fraîche provenant de résidus de culture, des parties de racines mortes et rhizomes et des apports organiques exogènes (par ex. amendements/engrais), et ii) l'horizon actif (couche du sol jusqu'à 30 cm de profondeur) où le COS est dégradé plus ou moins rapidement et

ensuite réémis dans l'atmosphère. Un bilan entrée / sorties du COS est ainsi possible à chaque pas de temps, ce qui permet de quantifier au final les teneurs en carbone organique des compartiments aériens et souterrains liées à une année particulière de culture.

Principaux résultats

Plusieurs points ont été abordés à travers ces travaux de thèse. L'article de la section 4.2 propose une approche de couplage (ici avec un modèle économique d'équilibre partiel, TIMES MIRET) pour évaluer des scénarios prospectifs pour le secteur des transports, en tenant compte des bilans dynamiques de C_{bio} des résidus de biomasse forestière pour la production de bioéthanol. Le couplage permet d'établir des bilans complets de C et de tenir compte des avantages potentiels de la séquestration de C_{bio} dans les arbres forestiers, représentés par des flux négatifs. Une analyse de sensibilité souligne que les résultats sont sensibles à la réduction de la longueur de rotation : plus la longueur de rotation modélisée est raccourcie, plus le bénéfice est faible.

Dans un l'article de la section 4.3, nous analysons les résultats du couplage du modèle d'équilibre partiel avec le modèle de croissance de biomasse forestière face à différentes perspectives temporelles de modélisation et nous discutons des défis de mise en œuvre, en particulier en ce qui concerne le choix de l'ordre de modélisation du cycle du carbone (séquestration-émission ou émission-séquestration, aussi représenté par le paradoxe de l'œuf et la poule). Des recommandations pour les praticiens sont proposées selon un ensemble de règles dans un arbre décisionnel. Les principaux éléments dépendent des changements entre les états précédents de la forêt (naturelle ou artificielle), en séparant les systèmes gérés des systèmes non gérés et en déterminant si les terres sont destinées à être reboisées après la récolte ou non.

L'article de la section 5.2 aborde la modélisation du COS pour différentes biomasses agricoles, afin de prendre plus précisément en compte les émissions de CO_2 dans l'atmosphère liée à la décomposition du COS au cours du temps. Cette approche est ici aussi couplée au modèle d'équilibre partiel du secteur énergétique français TIMES MIRET. Les dynamiques du COS de différentes cultures énergétiques ont été évaluées à partir de différents scénarios de déploiement des biocarburants. L'étude a démontré que les proportions de C ajouté au sol varient selon les différents types de biomasses agricoles et dépendent des pratiques de gestion des résidus en place (taux d'enlèvement des résidus en particulier), y compris la substitution partielle des engrais minéraux par des engrais organiques. L'analyse de sensibilité suggère que les forçages négatifs liés au COS diminuent considérablement avec la température et l'augmentation du taux d'enlèvement des résidus.

L'article de la section 5.3 est une étude de cas non publiée permettant d'aborder un autre domaine d'application. Le système étudié est la production d'un intermédiaire chimique (surfactant pour les produits d'hygiène personnelle), partiellement fabriqué à base d'alcool gras issu d'huile de palme. La

modélisation du C_{bio} et du SOC en amont et en aval, associé à une étude d'ACV statique traditionnelle "cradle-to-gate" (données fournies par un partenaire industriel), permet de comparer les résultats statiques et dynamiques. L'approche consiste en une intégration de tous les modèles déjà élaborés, mais avec une complexité accrue dans la modélisation de la croissance de tous les compartiments de la culture du palmier à huile, incluant tous les sous-produits.

Les défis de mise en œuvre

Les principales difficultés de mise en œuvre rencontrées dans le cadre de ces travaux sont données ci-dessous :

- Le paradoxe de l'œuf et la poule dans la séquestration de C_{bio} , un problème d'allocation : Les profils de séquestration à long terme ont un impact considérable, selon que la séquestration est prise en compte dans une perspective historique (avantage carbone) ou future (dette carbone). Cette décision de modélisation (relation physique causale de l'attribution de C_{bio} en amont ou en aval d'une activité de récolte) a été identifiée comme un défi d'allocation pour l'ACV attributionnelle.
- Impacts climatiques relatifs statiques ou dynamiques : Les comparaisons entre les résultats statique et dynamique de forçage radiatif relatif (exprimés en $\text{kg CO}_2\text{-eq}$) doivent être effectuées avec prudence, les deux métriques représentant des impacts différents. La principale incohérence réside dans les différents horizons temporels sous-jacents. La comparaison devient particulièrement difficile pour les études dont les limites temporelles ou les années d'inventaire sont différentes. Contrairement à la mesure relative, la mesure cumulative du forçage radiatif (exprimée en W yr m^{-2}) permet des comparaisons entre différents scénarios, avec différentes limites temporelles ou différentes années d'inventaire.
- Choix inévitable d'un horizon temporel dans l'analyse d'impact : Pour comparer une approche dynamique à une approche statique, un horizon temporel est nécessaire. Pourtant, l'approche dynamique exprime l'effet de forçage radiatif entre l'année d'une émission et la fin de l'horizon (par exemple 100 ans après le début du scénario étudié). Cela permet de voir les séquestrations dans leurs durées et les conséquences sur le réchauffement, contrairement à une approche statique.
- Coupure temporelle : Même si les inventaires dynamiques peuvent couvrir toutes les émissions potentielles décrites dans le temps, les émissions ayant lieu après la fin de l'horizon temporel ne sont pas prises en compte. Il est donc recommandé de fixer un horizon temporel de l'impact qui englobe la dernière émission dans l'inventaire.

Les principales sources d'incertitude dans ce travail sont listées ici :

- Données et accessibilité des données : Il n'est souvent pas facile d'obtenir des données précises pour la modélisation du C_{bio} par espèce végétale. En raison de l'absence de données

spécifiques au contexte français pour les rendements forestiers, des données provenant d'autres régions géographiques d'Europe ont été utilisées comme approximations, correspondant à minima aux conditions climatiques tempérées. De même, il n'est pas aisé d'obtenir des données sur la proportion de CH₄ provenant de la décomposition du COS en raison du manque d'études sur cette source d'émissions de GES. Les modélisations de la croissance de la biomasse et de COS sont basées sur des données de la littérature, ce qui entraîne une incertitude sur les résultats.

- **Dynamique spatiale - Données dites site-generic et site-specific :** Cette thèse porte principalement sur la dynamique temporelle des ressources biotiques pour réduire les incertitudes liées aux modèles linéaires et à la neutralité carbone. Les paramètres des modèles C_{bio} et COS de ce travail sont liés à des données dites site-dependent. Cela montre une relation étroite entre les dimensions temporelle et spatiale pour la modélisation des systèmes de la biomasse. Les conditions locales, c'est-à-dire les variables propres au site (p. ex. maladie, incendie, sécheresse, mortalité), jouent un rôle essentiel dans la modélisation des systèmes forestiers et agricoles. Cependant, l'aspect spatial ne pouvait être abordé dans le temps imparti.
- **Définition des limites du système :** La définition des limites du système peut représenter une source d'incertitude, car elle déterminera si tous les flux de C_{bio} et de COS en amont et aval sont pris en compte. Néanmoins, l'augmentation du nombre de sous-processus entraîne donc une augmentation naturelle de l'incertitude des processus, des données et de la modélisation. Le but et la portée de l'étude détermineront si un niveau élevé de détail dans la modélisation est nécessaire.

Les conclusions et perspectives

Cette thèse porte sur la façon de modéliser les effets du changement climatique à partir de flux de carbone biogénique provenant de systèmes forestiers et agricoles, et sur l'intégration de ces derniers dans le cadre de l'ACV dynamique. Les résultats ont montré l'importance de développer des inventaires dynamiques exhaustifs de carbone, biogénique et fossile, en s'appuyant sur les flux annuels de séquestration et d'émission tout au long du cycle de vie d'un bioproduit.

Les approches de modélisation ont contribué à l'élaboration d'une méthodologie d'ACV dynamique évaluant les effets climatiques des produits issus de la biomasse. Ces approches permettent de tenir compte des flux biogéniques, ce qui fournit une aide à la décision plus robuste dans la définition des mesures à prendre en réponse au changement climatique.

Le cadre proposé montre comment éviter les coupures temporelles dans l'inventaire, évaluer les émissions négatives, comparer les résultats dynamiques aux résultats des impacts statiques et comprendre l'évolution des émissions de GES à différents moments dans le temps.

La modélisation en amont de la séquestration du C_{bio} et du carbone du sol fournit une représentation plus précise des flux d'origine biogénique et de leurs potentiels effets d'atténuation du changement climatique. La prise en compte de la fin de vie a montré qu'il est essentiel d'effectuer une comptabilité dynamique sur toute la durée de vie pour capturer tous les échanges de carbone avec l'atmosphère et la technosphère dans le temps.

La modélisation de la croissance et de la séquestration du C_{bio} dépend du type de biomasse et n'est donc pas nécessaire dans tous les cas (récoltes de cultures annuelles par exemple). Cependant, la dynamique du COS doit être prise en compte pour tous les types de biomasses, si les résidus aériens et souterrains sont laissés sur le champ, et si les émissions liées à ces résidus n'ont pas lieu instantanément. La biomasse morte a sa propre dynamique, car elle subit des processus de dégradation pouvant différer selon les conditions pédoclimatiques.

L'ACV dynamique réduit donc le biais dans les résultats d'atténuation du changement climatique. Cependant, le choix d'un horizon temporel reste inévitable et des analyses de sensibilité doivent être réalisées pour mieux interpréter les résultats finaux, en particulier en ce qui concerne la séquestration du C_{bio} de biomasse à longue rotation issue de la forêt.

Pour les études futures, il est recommandé d'inclure la dynamique spatiale dans les approches de modélisation du carbone, en spécifiant en particulier les rendements en fonction du site pour mieux comprendre comment les dimensions temporelle et spatiale doivent être réalisées ensemble pour le développement de l'ACV dynamique. Il peut s'agir d'une considération essentielle également pour d'autres catégories d'impact. D'autres progrès sont nécessaires pour quantifier les effets du changement climatique qui sont liés aux changements d'usages des sols, directs ou indirects, souvent en relation avec l'expansion de la biomasse pour la bioénergie ou vers le développement de la bioéconomie.

Table of contents

Acknowledgements	i
Declaration	ii
Abstract	iii
Résumé	iv
Resumen ejecutivo	v
Zusammenfassung	vi
Résumé substantiel	vii
Table of contents	xvi
List of tables	xx
List of figures	xxi
List of boxes	xxiii
List of acronyms and abbreviations	xxiv
Foreword	xxx
1 Introduction	2
1.1 Background: the global carbon cycle	2
1.2 Current assessment limitations under carbon neutrality assumptions	4
1.3 Thesis overview	5
1.3.1 Research objectives and scope.....	5
1.3.2 Thesis strategy	6
1.3.3 Thesis structure.....	7
2 Literature review: From static to dynamic carbon modelling	11
2.1 Chapter context	11
2.2 Climate system and climate change mitigation strategies	11
2.2.1 Net global energy balance	11
2.2.2 Key drivers of and main contributing sectors to climate change	13
2.2.3 Climate policy context and mitigation initiatives	16
2.2.4 Climate change policy framework.....	19
2.2.5 IPCC climate metrics used in policy and tools	21
2.3 Life cycle assessment: concept and framework	24
2.3.1 Life cycle thinking and management conceptualisation	25
2.3.2 The standardised framework.....	26
2.3.3 Main modelling approaches.....	29
2.3.4 General limitations	33
2.4 Life cycle assessment: temporal limitations.....	34
2.4.1 Static/linear computational structure of LCA	34
2.4.2 Background system modelling and datasets featuring linear coefficients	35
2.4.3 Static modelling of elementary flows in LCI.....	35
2.4.4 Time horizon choice in LCIA.....	36
2.4.5 Temporal boundaries: time preferences.....	38
2.4.6 Prospective time horizon and scenario-driven perspectives	41
2.5 Methodological developments for climate change in life cycle impact assessment.....	42
2.5.1 Spatial-dynamic oriented	42
2.5.2 Climate target oriented	42
2.5.3 Biogenic carbon oriented.....	43

2.5.4	Temporary carbon storage in biomaterials	45
2.5.5	Biogenic and soil-sourced carbon emissions and storage from bioenergy	46
2.5.6	Dynamic LCA	48
2.6	Carbon modelling for life cycle inventories.....	52
2.6.1	Modelling biogenic carbon from biomass	53
2.6.2	Modelling soil organic carbon in the context of land use/land use change.....	61
2.6.3	Linking land use, soil organic carbon and climate change in life cycle assessment.....	67
2.6.4	Current carbon modelling standards and guidelines	70
2.7	Chapter conclusion.....	73
3	A framework for dynamic carbon modelling in LCA.....	76
3.1	Chapter context	76
3.2	Framework proposal: dynamic carbon modelling for dynamic LCA.....	76
3.3	Elements for dynamic modelling along the life cycle phases	79
3.3.1	Goal and scope phase: consideration of the time dimension	79
3.3.2	Dynamic LCI: timing of the emission flows.....	83
3.3.3	Dynamic LCIA: time-dependent characterisation factors	89
3.3.4	Life cycle interpretation.....	90
3.4	Simplified cradle-to-grave carbon cycle model example	90
3.4.1	Introduction	90
3.4.2	Goal and scope	91
3.4.3	Dynamic LCI.....	95
3.4.4	Dynamic LCIA	97
3.4.5	Interpretation and conclusions	101
	References for 3.4.....	102
3.5	Chapter conclusion.....	104
4	Forestry: growth modelling.....	107
4.1	Chapter context	107
4.2	Paper 1: Model coupling in the context of forest bioenergy demand.....	111
	Highlights	111
	Abstract	112
	1. Introduction	113
	2 Material and method.....	115
	3. Results and discussion	126
	4. Conclusions	138
	References for Paper 1.....	139
4.3	Paper 2: Chicken-egg dilemma in the context forest carbon accounting	148
	Abstract	149
	1 Introduction.....	150
	2 Materials and methods	153
	3 Results.....	160
	4 Discussion.....	165
	5 Conclusions	172
	References for Paper 2	173
4.5	Chapter conclusions	182

5	Agriculture: Soil organic carbon modelling.....	184
5.1	Chapter context	184
5.2	Paper 3: Soil organic carbon in the context of energy crops	187
	Graphical abstract	188
	Highlights	188
	Abstract	188
	1 Introduction	189
	2 Material and methods	194
	3 Results and discussion	201
	4 Conclusions	213
	References for Paper 3.....	214
5.3	Manuscript 5: Model integration in the context of oil palm-based surfactants	223
	Abstract	224
	1 Introduction	224
	2 Material and methods	226
	3 Results and discussion	237
	4 Conclusions	243
	References for Manuscript 5.....	244
5.4	Chapter conclusion.....	248
6	Discussion: elements of dynamic carbon cycle modelling.....	250
6.1	Chapter context	250
6.2	Synthesis of the main findings	251
	6.2.1 Dynamic upstream carbon modelling.....	251
	6.2.2 Coupling carbon modelling with demand models	253
6.3	General implementation challenges and sources of uncertainty	255
	6.3.1 Modelling challenges.....	255
	6.3.2 Sources of uncertainty and limitations.....	256
6.4	Identified limitations from the GWPBio due to dynamic carbon modelling.....	258
6.5	Chapter conclusion.....	260
7	Conclusions and directions for further research	262
7.1	Overall conclusion	262
	7.1.1 Conclusions on the proposed modelling framework.....	262
	7.1.2 Remarks on climate change and mitigation approaches	264
7.2	Directions for further research	265
	7.2.1 Explore other impact methods for GHG and non-GHG climate forcers.....	266
	7.2.2 Combine spatio-temporal modelling approaches.....	267
	7.2.3 Develop integrated multi-criteria modelling approaches	267
	7.2.4 Support LCA guideline through dynamic approaches and results	268
	7.2.5 Conduct multi-indicator dynamic soil (carbon) modelling	268
	7.2.6 Integrate land-use modelling in policy scenarios.....	269
	7.2.7 Other considerations	269
	References.....	271
	Appendices.....	300

Appendix A: Paper 4 – Review paper on the time consideration in LCA	300
Abstract	302
1 Introduction.....	302
2 Proposed Glossary.....	303
3 Temporal considerations in different LCA phases.....	305
4 Proposed Development Pathways	320
5 Conclusions.....	326
References for Paper 4.....	327
Appendix B: SOM models	338
Appendix C: Biomass pathways.....	341
Appendix D: Data paper on forest models	342
Abstract	342
1 Data.....	344
2 Experimental Design, Materials, and Methods	347
References for Appendix D	350
Appendix E: SM of Paper 2	353
1 Static versus dynamic LCA approaches.....	353
2 Partial-equilibrium model (TIMES-MIRET) outputs	353
3 Outputs from forest carbon modelling	356
Appendix F: SM of Paper 3.....	358
Abstract	358
1 Pre-treatment of techno-economic data for the coupling	358
2 Soil organic carbon modelling	360
3. Calculation of plant carbon allocation and soil organic carbon inputs.....	364
4 Computed time-dynamic soil organic carbon flows per management scenario	367
5 Coupling results and sensitivity analysis	375
References for Appendix F	376
Appendix G: SM of Manuscript 5	379
1 Biomass proportions	379
2 Biogenic carbon fixation during biomass growth	379
3 Biogenic carbon to the soil.....	380
4 Dynamic full lifetime carbon accounting factors	382

List of tables

Table 2.1: Atmospheric lifetime, GWP and GTP factors of three main climate forcers	24
Table 2.2. Main differences between attributional and consequential LCA	29
Table 2.3: Examples of questions addressed by different LCA modes	32
Table 2.4. Main approaches for C_{bio} modelling and assessment in attributional LCA	49
Table 2.5. Operational difference between static and dynamic LCA.....	49
Table 2.6: Methodological aspects and recommendations in technical standards and guidelines related with carbon modelling.....	72
Table 2.7. Temporal limitation in LCA with special focus on climate change, perspectives and relevance.....	74
Table 3.1. Key design questions in dynamic biomass-based carbon models	87
Table 3.2. Biogenic carbon flows and net balance for lumber over three life cycle inventory time horizons.....	97
Table 3.3. Biogenic carbon flows and net balance for co-production over three life cycle inventory time horizons	97
Table 3.4 Static vs dynamic climate change impacts of lumber over impact time horizon of 20 and 100 years ..	99
Table 3.5 Static vs dynamic climate change impacts of co-production over impact time horizon of 20 and 100 years	99

List of figures

Fig. 1-1: Simplified scheme of the carbon pools in the global carbon cycle, adapted from Ciais et al. (2013, p. 471, IPCC AR5).....	3
Fig. 1-2. Static classic versus dynamic life cycle assessment (LCA) approaches. Source: A. Hélias, 2019, pers. comm.....	6
Fig. 1-3. Strategic approach of the thesis	7
Fig. 1-4: Simplified structure of the thesis with chapter and paper contents	7
Fig. 2-1: Estimate of the Earth’s annual and global mean energy balance. Source: (Cubasch et al. 2013, IPCC AR5, Chapter 1)	12
Fig. 2-2: Climate forcing compounds at global and local scales. Source: adapted from Levasseur et al. (2016), and Cherubini et al. (2016).....	13
Fig. 2-3. Global primary energy consumption by fuel source compared to France’s in the year 2017. Source: (BP, 2018)	15
Fig. 2-4. Greenhouse gas emissions by IPCC sector of the EU-28 in the year 2016. Source: (Eurostat, 2019) ...	15
Fig. 2-5. Final EU biomass use in electricity, heating and cooling and transport, with achieved values in 2005-2012 and projections in 2020. Source: Adapted from Scarlat et al., (2015).....	18
Fig. 2-6: The cause–effect chain from GHG emissions to climate change, impacts and damages. Source: (Myhre et al., 2013a) adapted from Fuglestvedt et al. (2003).....	20
Fig. 2-7. Simplified impact pathways for climate change linking elementary flows for the inventory to the areas of protection. Source: (Hauschild and Huijbregts 2015, p. 9).....	21
Fig. 2-8: Life cycle thinking of a product with closing the loop (recycling, reuse, recovery). Source: (UN Environment/SETAC, 2006).....	25
Fig. 2-9: LCA stages and direct applications. Source: (ISO, 2006a)	27
Fig. 2-10. Difference in scope and completeness between LCA and carbon footprint, yet both applying the life cycle perspective. Source: (Rosenbaum et al. 2018, Chapter 10)	28
Fig. 2-11. Management of multi-functionality: a) allocation vs. b) system expansion	31
Fig. 2-12. Dynamic time steps of elementary flows inherent to the climate change impact category. Source: adapted from Collet et al. (2014)	36
Fig. 2-13: Short- to long-term time preferences by cultural perspectives associated with the climate change	39
Fig. 2-14. Discount rate equivalent to a time horizon. Source: Fearnside (2002a)	40
Fig. 2-15. Mapping static (S) and dynamic (D) methods, linking fossil and biogenic carbon, soil organic carbon and climate change. Source: adapted from Benoist and Bessou (2018).....	44
Fig. 2-16. Mapping of methods linking biogenic carbon, soil organic carbon, and land use with climate change. Source: adapted from Benoist and Bessou (2018)	45
Fig. 2-17: GWP _{Bio} approach with a) clear cut harvest and combustion, and b) immediate regrowth over a full rotation period. Source: Cherubini, 60 th LCA forum presentation (2015)	47
Fig. 2-18. Time-dependent radiative forcing approach. Source: Annie Levasseur, CIRAIG	50
Fig. 2-19. Dynamic C _{bio} exchanges between production system and atmosphere. Source: Peñaloza et al. (2016)60	

Fig. 2-20. Main variables and processes,for dynamic soil organic carbon modelling. Source: adapted from Luo et al. (2016)	63
Fig. 2-21. Impact pathways for land use of pre-selected models in LCA. Source: (Vidal Legaz et al., 2016)	67
Fig. 3-1. Proposed framework for dynamic carbon modelling in life cycle assessment	78
Fig. 3-2. Biomass-sourced process pathways to bioenergy or biomaterials and biochemicals	80
Fig. 3-3. Main temporal implications of classical static and dynamic LCA approaches at the inventory and impact assessment level	83
Fig. 3-4: Carbon exchange flows between the atmosphere, biomass compartments and soil along the bioproducts life cycle phases	84
Fig. 3-5. Dynamic life cycles of biomass-based products featuring the classic phases associated with biomass extraction, transformation use and end-of-life and the inclusion of the time dimention (highlighted with the upwards file) at each phase from upstream to downstream modelling, whereas a emission delay (i.e. carbon storage) inbetween may emerge.	85
Fig. 3-6. Temporal consideration in biomass systems, upstream.....	86
Fig. 3-7. Temporal consideration in biomass systems by means of scenarios, downstream.....	89
Fig. 3-8. U.S. Forest Service Resources Planning Act timber assessment regions (Adams et al. 2006).....	91
Fig. 3-9. Life cycle processes of wood construction materials with assumptions undertake	92
Fig. 3-10. Overview of assumptions undertaken for dynamic modelling of one tonne of biogenic carbon (C_{bio})	94
Fig. 3-11. Dynamic LCI results of both emissions biogenic CO_2 (in red, left-handed y-axis) and biogenic CH_4 (in blue, right-handed y-axis) from the cradle-to-grave lumber product [$t C_{bio}$]	96
Fig. 3-12. Dynamic impact assessment of the lumber and co-production system denoting LCIA TH of 220 and 300 years	98
Fig. 3-13. Static and dynamic impact assessment of lumber and co-production over LCIA THs 20 and 100 years	100
Fig. 3-14. Long-term dynamic forcing effects over a LCIA TH of 500 year of lumber and co-production	101
Fig. 3-15. Links among papers and framework elements (the thesis paper assigned to each subject was that where the subject was explored in more detail).....	105
Fig. 4-1. Detailed modelling framework for dynamic biogenic carbon from forestry systems and coupling with demand models	109
Fig. 6-1. Selected time-dynamic elements addressed (boxes third row) in this dissertation according to the identified issues (boxes middle row) along the life cycle phases (boxes first row)	250

List of boxes

Box 2-1. Areas of protection	21
Box 2-2. Computational structure of life cycle assessment.....	34
Box 2-3. Cultural perspectives in LCA.....	38
Box 2-4. Time-discounting preferences	40
Box 2-5. Energy system models (prospective scenarios).....	41
Box 2-6. Available tools for dynamic LCA	51
Box 2-7. Biogenic carbon stock approaches of bioenergy and fossil carbon displacement	54
Box 2-8. Biomass growth modelling.....	56
Box 2-9. Dynamic carbon accounting in LCA of buildings.....	59
Box 2-10. The pioneering Hénin and Dupuis soil carbon model and multiple pool modelling.....	64
Box 2-11. Main terminology associated with land use and land use change	68
Box 4-1. Data specification on yield tables.....	110
Box 5-1. Net Primary Production.....	186

List of acronyms and abbreviations

1G	First Generation	ISO	International Standardisation Organisation
2G	Second Generation		
aGWP	Absolute Global Warming Potential	JI	Joint Implementation
ALCA	Attributional Life Cycle Assessment	LCA	Life Cycle Assessment
AoP	Areas Of Protection	LGC	Lignocellulosic
BAU	Business-As-Usual	LCI	Life Cycle Inventory
C	Carbon	LCIA	Life Cycle Impact Assessment
C _{bio}	Biogenic Carbon	LCT	Life Cycle Thinking
CDM	Clean Development Mechanisms	LTECV	French Energy Transition For Green Growth Act
CER	Certified Emission Reduction		
CF	Characterisation Factor	LULUC	Land Use And Land Use Change
CH ₄	Methane	LULUCF	Land Use, Land Use Change And Forestry
CLCA	Consequential Life Cycle Assessment		
CO	Carbon Monoxide	MARKAL	Market Allocation
CO ₂	Carbon Dioxide	N ₂ O	Nitrous Oxide
CO ₂ -eq	Carbon Dioxide Equivalent	NOx	Nitrogen Oxides
COP	Conference Of Parties	NTCF	Near-Term Climate Forcers
dLUC	Direct Land Use Change	PEM	Partial-Equilibrium Model
EC-JRC	European Commission Joint Research Centre	RE	Renewable Energy
EOL	End-Of-Life	SOC	Soil organic carbon
FoWooR	Forest Wood Residues	SOM	Soil organic matter
GHG	Greenhouse Gas	SOx	Sulphur Oxides
GTP	Global Mean Temperature Potential	TH	Time Horizon
GWP	Global Warming Potential	TIMES	The Integrated Markal-Efom System
ILCD	International Reference Life Cycle Data System	UNFCCC	United Nations Framework Convention On Climate Change
iLUC	Indirect Land Use Change	VOC	Volatile Organic Compound
IPCC	International Panel On Climate Change	WMGHG	Well-Mixed Greenhouse Gas
IRF	Impulse Response Function		

Foreword

Background and research context:

This research project has been conducted with the financial support of the French Institute IFP Energies nouvelles (IFPEN), division of Economics & Technology Intelligence, by a fulltime PhD position over a three-year contracting period from 01 November 2016 to 31 October 2019, promoted by Pierre COLLET, summarising the following research context:

“The vast majority of Life Cycle Assessments (LCAs) to date rely on the representation of static systems, whether at the level of system modelling (Life Cycle Inventory/LCI) or at the level of calculating environmental impacts related to inventory flows (Life Cycle Impact Assessment/LCIA). While this simplification is clearly identified as one of the main limitations in current practice, there is currently little research on the consideration of time in LCA. This lack of consideration of the time dimension is an important bias because, for instance, the impacts related to end-of-life processes are calculated on the same basis as those of the production phases, even though the associated emissions are postponed for several decades. Moreover, when comparing the climate change impacts of bio-sourced products with fossil equivalents, the benefits of temporarily storing biogenic carbon during the use phase(s) of the product cannot be taken into account”.

Specifications on the administrative framework:

The work was carried out to 70% in Montpellier SupAgro University with the affiliate research unit INRA-LBE – Laboratory of Environmental Biotechnology and the research group ELSA – Environmental Life Cycle and Sustainability Assessment, supervised by the thesis director Arnaud HELIAS. Partnering research affiliations were CIRAD – Agricultural Research for Development, with co-supervision by Anthony BENOIST (Researcher in the UPR Unit Biomass, Wood, Energy, Bioproducts). Moreover, a partnership with the company Solvay was established in collaboration with Jean-Francois VIOT (Senior Principal Scientist).

Participation in international conferences:

- SETAC Europe 28th Annual Meeting 13-17 Mai 2018 Rome, Italia (platform presentation)
- LCA FOOD 17-19 Nov 2018 Bangkok, Thailand (platform presentation)
- BioeconomyWorkshop 29-30 Oct Paris, France (member of the young scientist panel)

Deliverable reports, manuscripts and publications:

- IFPEN mid-term thesis report: status of the research with preliminary results.
- Data Paper (first author, published): Data and non-linear models for the estimation of biomass growth and carbon fixation in managed forests
- Paper 1 (first author, published): Coupling partial-equilibrium and dynamic biogenic carbon models to assess future transport scenarios in France
- Paper 2 (first author, published): Back to the future: Dynamic full carbon accounting applied to prospective bioenergy scenarios
- Paper 3 (first author, under review, minor revision) Modelling dynamic soil organic carbon flows of annual and perennial energy crops to inform energy-transport policy scenarios in France
- Paper 4: (second author, under review): Temporal Considerations in Life Cycle Assessment: A Review
- Manuscript 5: (first author, case study): Full lifetime dynamic biogenic carbon modelling of oil palm applied to biochemical surfactant
- Excel tool for dynamic carbon modelling: elaboration of an own tool allowing to couple technical flows as outputs from other demand models and making simulations of associated dynamic carbon flows.

Formation and seminars:

The doctoral programme included the participation in different training courses and seminars, throughout the three-years, most of which have been offered in the context the IFP College Doctoral under the direction of Andreas EHINGER, as well as provided by ELSA or GAIA Doctoral School –in total 191 hours of formation).

Special skills development during the PhD thesis:

The multi-disciplinary character of this thesis project taught me the capability to handle a high workload and perform efficiently in a wide range of demanding settings. This has given me the confidence to be able to quickly learn and apply different tasks with little or no previous knowledge on the topic (e.g. forestry or agricultural sciences). Moreover, it has showed me to be persistent and self-motivated to achieve my objectives. These skills will be functional into my future career path.

Professional ambition:

What drives me? Environmental studies are necessary, on the one hand we need to understand the carrying capacity of our one and only Earth system, for the sake of human well-being and ecosystems (as the evidence shows with the global warming). International openness in an increasing globalised economy allows sharing scientific knowledge and conceives different values in order to better advance and find adapted and innovative solutions. After the PhD project I see myself as a researcher in the area of environmental sustainability, bio-economy, renewable energy and waste management. I keep an eye on professional opportunities in applied sciences in the industry or international agencies delivering projects in Europe or developing countries.

Chapter 1: Introduction

1 Introduction

1.1 Background: the global carbon cycle

Human activities contribute to the increasing Greenhouse Gas (GHG) concentration in the atmosphere, causing Earth's surface temperature rise leading to climate change – a global threat, with ultimate damages to human health and ecosystems. The growing need to reduce GHG emissions to mitigate climate change and associated risks demands alternative solutions, among others, deriving from renewable energy carriers, carbon capture and storage, sustainable consumption and production patterns, sustainable lifestyle, for present and future generations.

Global commitments have implemented ambitious climate targets and intervention policies in the frame of the Kyoto Protocol mechanisms and Paris Agreement towards low-carbon nations and low-throughput societies, to not overstepping the 450 ppm or the 2°C limit (UNFCCC, 2018).

The effects from alternative energy carriers and materials on the global system require a better understanding of what low-carbon, carbon neutral or negative emissions means to support the transition towards renewable energy carriers.

Carbon (C) releases have a direct effect on the net energy balance of the Earth climate system due to increased atmospheric concentration of GHGs. The global carbon cycle plays an essential role in the Earth climate feedback mechanisms, representing the exchanging carbon flows between the carbon pools atmosphere, biosphere, pedosphere, hydrosphere and lithosphere (Fig. 1-1). The carbon pools act as carbon sinks with different turnover times (i.e. mass of carbon relative to the exchange rate), ranging from a few days to millions of years. The atmosphere, ocean and freshwater, vegetation and soils have a fast turnover time as compared to the slow lithosphere pool (Ciais et al. 2013, IPCC AR4, Chapter 6).

The **atmospheric pool**, comprises GHGs such as carbon dioxide (CO₂), followed by methane (CH₄), carbon monoxide (CO), nitrous oxide (N₂O), hydrocarbons, ozone, water vapour, and particulate matter (e.g. black carbon, aerosols). The substances have different turnover times, referred to as atmospheric lifetimes, ranging from days for Near-term climate forcers to centuries for CO₂. The terrestrial biological pool comprises the carbon fixed in plants (living biomass) within the **biosphere** and in the soil organic matter (dead biomass) within the **pedosphere**. Atmospheric CO₂ is fixed in the biomass through photosynthetic processes and released back by autotrophic and heterotrophic respiration. The **oceanic pool** is the largest carbon sink, composed of both dissolved inorganic and organic carbon compounds, which are transferred between different oceanic layers. The turnover time in the upper layer is fast, while the sea floor stores C in the sediments for centuries to millennia due to

biological processes. The **lithospheric pool** refers to the geological sink (fossil carbon) with long turnover time.

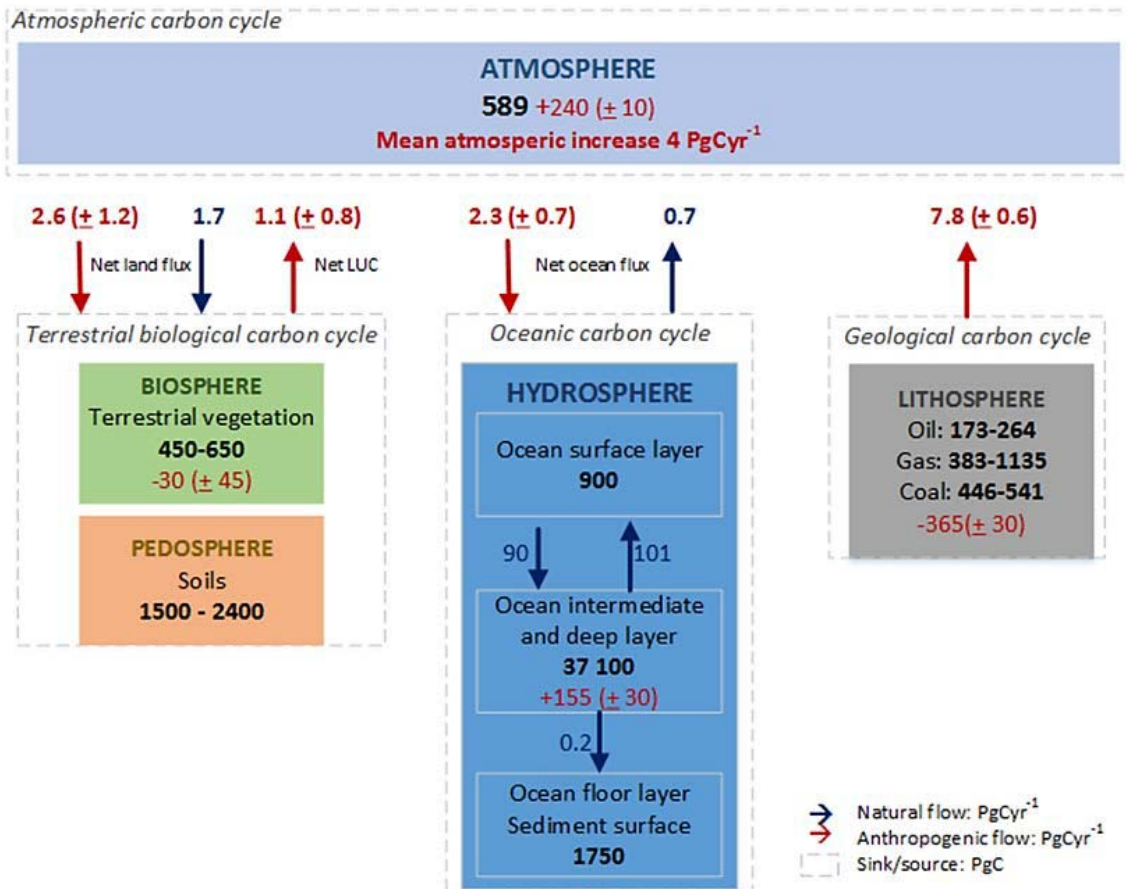

Note: Natural flows prior to the Industrial Era (1750) in black, anthropogenic flows (2000 -2009) in red, and sinks expressed in PgC [1 PgC=10E15 gC = 1GtC]

Fig. 1-1: Simplified scheme of the carbon pools in the global carbon cycle, adapted from Ciais et al. (2013, p. 471, IPCC AR5)

Since the pre-industrial era (year 1750), carbon has been transferred from a slow turnover compartment (lithosphere) into a fast one (atmosphere) due to anthropogenic activities, principally driven by fossil fuel combustion (Forster et al. 2007; Myhre et al. 2013a).

Biomass, in the terrestrial biological carbon pool, has gained attention in the climate mitigation context, given that this feedstock can be regrown, referring to it as a renewable resource. It can displace fossil C for a wide range of products and derivatives towards future multiproduct biorefinery (bioenergy, biomaterials and intermediate biochemicals), as the C stored in the biomass (referred to as C_{bio} – biogenic carbon) is an essential building block, representing about half of the dry mass in the vegetation, as a default value (FAO, 2005). Climate mitigation incentives thus turn to crediting/offsetting the avoided equivalent fossil C by the renewable feedstock.

C_{bio} emissions from bioenergy systems are considered to be zero under the **carbon neutral hypothesis**, i.e. one unit of carbon released to the air is balanced out through the same unit of carbon fixed in the biomass during plant growth and regrowth. That is to say, the same amount of CO_2 emitted from combustion or incineration has been or will be removed from the atmosphere during plant growth or regrowth, which thus allows omitting the related biogenic CO_2 from the GHG inventories. Most of currently applied modelling approaches used in science and policy rely on this hypothesis.

The carbon neutral assumption has been questioned by several scholars across scales (Benoist and Dron, 2009; Johnson, 2009; Schulze et al., 2012) and confronted in terms of long-term climate change effects and mitigation projects. It has been stated that carbon neutrality leads to absurd conclusions favouring burning tropical forests (Rabl et al., 2007) and incorrect treatment of, for instance, forest-sourced bioenergy (Searchinger et al., 2009). The International Energy Agency (IEA) Task 38 group (<http://task38.ieabioenergy.com/>) has been formed to enhance the understanding on the subject, particularly concerned with climate effects of biomass and bioenergy systems to overcome current research gaps, among others, on the timing of forest carbon stocks (Cowie et al., 2013).

While there is a fundamental difference between GHG inventories at national, landscape/project or product level, this dissertation centres on the last one in the context of Life Cycle Assessment (LCA), facing the assessment limitations describe in the next section.

1.2 Current assessment limitations under carbon neutrality assumptions

Climate change impacts have steady-state representations of the cause-effect relationship between an anthropogenic activity and an emission release. The effects from an activity are commonly scaled by means of static emission factors (Heijungs and Suh, 2002).

The commonly used method to assess climate change impacts is the IPCC Global Warming Potential (GWP) metric (Myhre et al., 2013a). The metric represents a relative measure of the weighted sum (in mass values) of all inventoried GHG emissions (i), resulting from an anthropogenic activity (e.g. by the provision of goods and services), over a fixed time horizon (TH), as shown in Eq. 1-1.

$$\text{Climate change impact [kg } CO_2\text{eq} \cdot kg^{-1}] = \sum_i \text{Mass of a } GHG_i \times GWP_i(TH) \quad \text{Eq. 1-1}$$

In LCA or carbon footprint approaches, all GHG emissions from different process activities are added up, after being weighted by the corresponding static GWP factor (or characterisation factor in LCA terminology), ignoring the **temporal variability** of emission flows and their actual impacts. Temporal information is lost, as it does not specify when in time an emission takes place (Benoist, 2009; Collet, 2012; Hellweg and Frischknecht, 2004; Levasseur et al., 2010a).

The static approach excludes dynamic C_{bio} flows, with no effect on the GHG balance, thus resulting in zero CO_2 emissions, justified by the carbon neutral hypothesis (Cherubini et al., 2011a). The net carbon exchange with the atmosphere may be neutral; however, the timing of the carbon sequestration and storage, as well as emission delays may vary substantially, depending on the product type, constituting in an essential source of uncertainty in the results.

The accounting problematic and challenges associated with C_{bio} and the time dimension were thoroughly discussed in expert meetings (Agostini et al., 2014; Brandão and Levasseur, 2010). New approaches, methods or tools were then proposed, such as Dyn CO_2 tool for dynamic LCA by Levasseur et al. (2010), GWP_{Bio} metric for bioenergy systems by Cherubini et al. (2011), or the DyPLCA tool for dynamic processes by Tiruta-Barna et al. (2016), to name a few. However, despite these different contributions, no consensus has been established in the LCA community on how to treat and account time-dependent flows in LCA of biomass-based systems or products.

Appropriate C_{bio} modelling approaches in LCA are still lacking, opening the following research questions:

- How to define temporal carbon profiles of disaggregated flows?
- What approaches enable dynamic accounting for C_{bio} from the biotic production?
- How can dynamic approaches be implemented in the LCA framework?
- Can negative C_{bio} emissions be valued? Or is carbon neutrality of C_{bio} inherently justifiable?

1.3 Thesis overview

1.3.1 Research objectives and scope

Given the current static assessment limitations, this PhD dissertation is devoted to bridging the gap between the time dimension and carbon modelling within the dynamic LCA framework and climate change impact category, under the given hypothesis: “Temporal biogenic emission profiles provide a more accurate picture of actual climate change and mitigation potentials, for instance, towards climate targets, and are thus non-negligible.”

Fig. 1-2 exemplarily illustrates a system under study with temporal differentiation of the flows concerning positive emission (fossil- or biogenic-sourced) to the atmosphere and negative fixation into the biomass, as well as two assessment approaches in LCA concerning static classic and dynamic methods. **The main objective of this dissertation is thus to assess time-sensitive climate change effects and mitigation potentials from biogenic and fossil C sources, and analyse whether static and dynamic carbon neutral results are considerably affected under temporal considerations.**

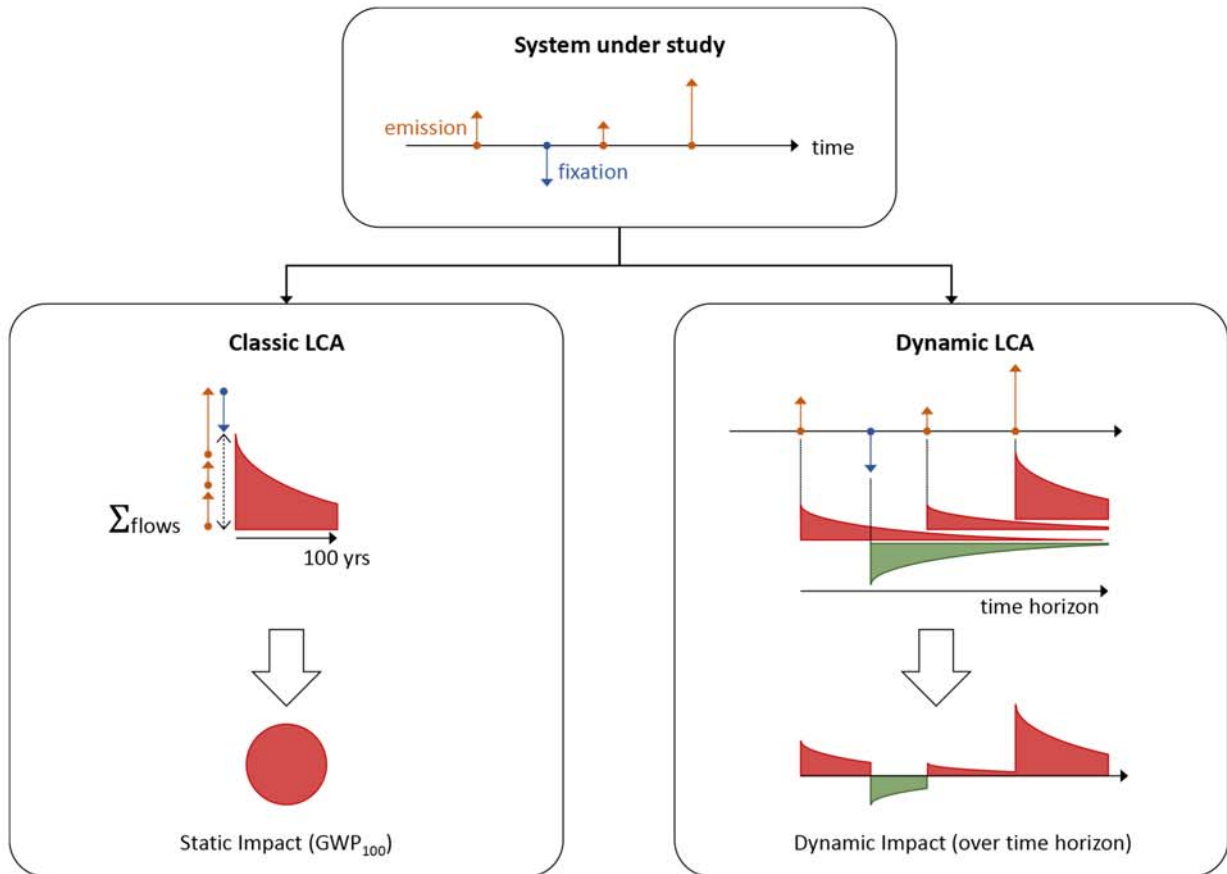

Fig. 1-2. Static classic versus dynamic life cycle assessment (LCA) approaches. Source: A. Hélias, 2019, pers. comm.

The objective is expected to be achieved under the following targets and objectives:

- 1 Assess the dynamic/time-dependent input and output carbon flows alongside the life cycle phases of biomass-based products, involving:
 - a) Managed commercial upstream systems (e.g. forestry and agriculture), considering living and dead biomass in aboveground and belowground compartments; and
 - b) Downstream systems representing end-of-life (EOL) scenarios of bioproducts.
- 2 Develop a framework proposal for dynamic carbon modelling towards a harmonised and consistent accounting method for dynamic LCA and/or carbon footprints.

1.3.2 Thesis strategy

The dissertation follows a cross-disciplinary research strategy (involving ecology, forestry, agriculture, land use and policy) to assess the climate change consequences from human economic activities (biomass-sourced products) by means of combining the dynamic LCA framework and intervention modelling, as shown in Fig. 1-3.

Biomass-sourced products (e.g. advanced biofuels) are innovative and still produced at lower scales. Therefore, the integration of prospective economic approaches, involving technological innovation, market dynamics, and related externalities are considered relevant in this research.

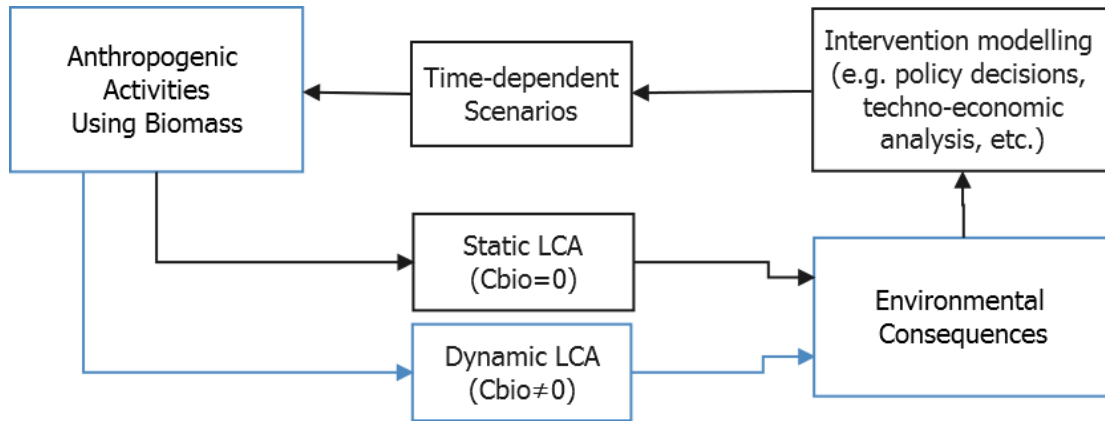

Fig. 1-3. Strategic approach of the thesis

1.3.3 Thesis structure

The dissertation is composed of seven chapters illustrated in Fig. 1-4. The structure of the chapters is organised in a way that the state of the art, highlighting existing approaches and research gaps, feeds a framework proposal for dynamic carbon modelling, which is further explored by means of case studies, addressing the framework elements, and finally identify the applicability and implementation challenges of the framework proposal.

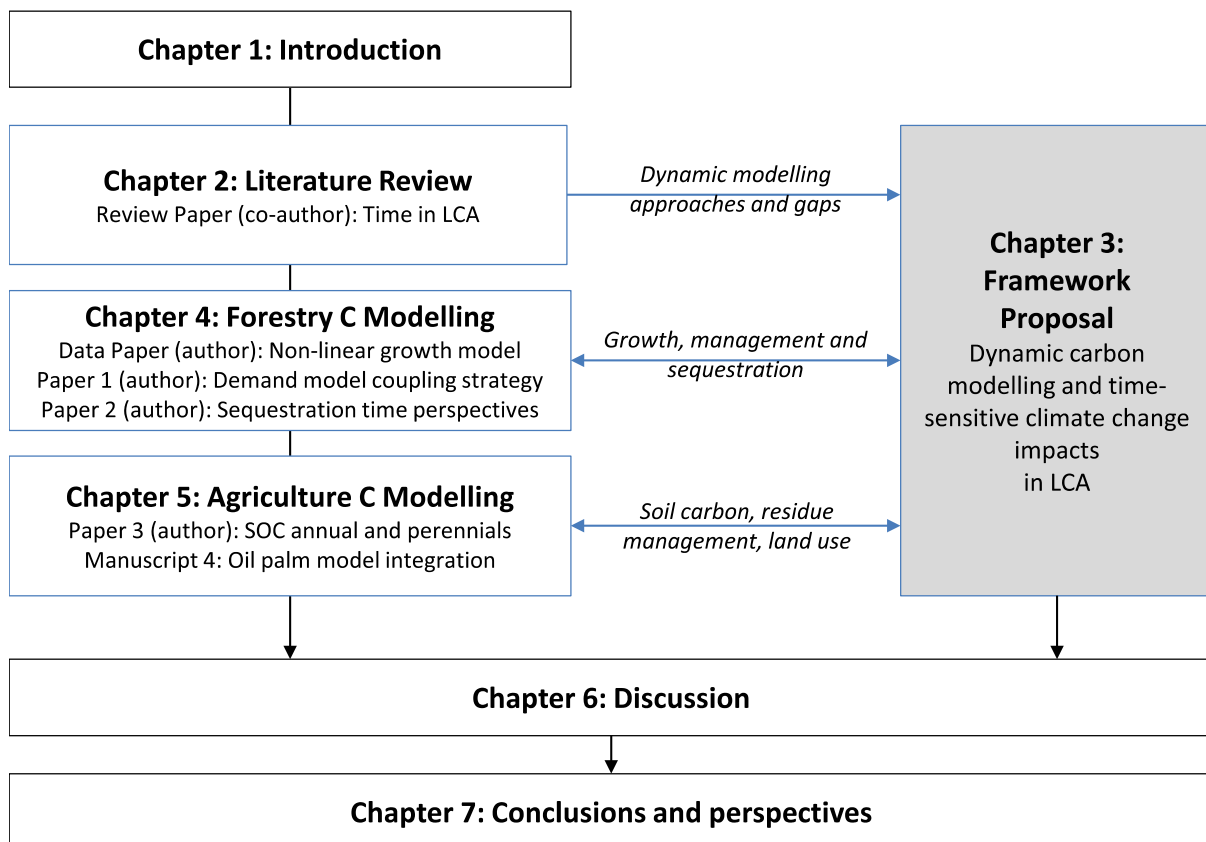

Fig. 1-4: Simplified structure of the thesis with chapter and paper contents

Chapter 1: Introduction

The Chapter contents, including published papers and submitted manuscripts, as well as modelling data and specifications outlined in the Appendices, consist of:

Chapter 1 Introduction: provides a short introduction of the research context and further detailing the objectives and envisioned strategy on how this work intends to bridge current gaps between the time dimension and LCA.

Chapter 2 Literature review: From static to dynamic carbon modelling: presents the theoretical foundation of this work, including background information from climate science and climate change (the priority set to for the impact category), followed by a holistic review of the LCA framework, current general temporal limitations and existing methodological developments, particularly concerning time implications in the assessment of dynamic carbon flows, with special emphasis on biogenic and soil organic carbon modelling. Some of the reviewed elements concerning the temporal limitations in LCA are partial contributions to a Review Paper as second co-author (Manuscript 1 in Appendix A: Paper 4 – Review paper on the time consideration in LCA).

Chapter 3 A framework for dynamic carbon modelling: describes in detail a framework proposal, prior to the elaboration of case studies in Chapter 4 (forestry-related) and Chapter 5 (agriculture-related), with the purpose of consolidating and detailing the main findings from literature on existing dynamic elements and gaps, required for conducting time-dependent carbon modelling approaches. The framework is aligned to the LCA phases, with special focus on the life cycle inventory phase. This Chapter includes a detailed cradle-to-gate study on a wood lumber co-product as an implementation example of the framework proposal.

Chapter 4 Forestry: growth modelling: commits to dynamic upstream modelling of forestry systems and bioenergy to capture carbon sequestration in the biomass through dynamic growth models and allometric relations, as well as to analyse different modelling time perspectives (historic and future accounting flows) and their implications in dynamic LCA. The modelling approach delivers three published papers:

- Data paper (Appendix D: Data paper on forest models): Data and non-linear models for the estimation of biomass growth and carbon fixation in managed forests. Publication alongside the Supplementary Material accessible in the Journal Data in Brief, issued on 16 March 2019 (<https://doi.org/10.1016/j.dib.2019.103841>).
- Paper 1 (section 4.2): Coupling partial-equilibrium and dynamic biogenic carbon models to assess future transport scenarios in France. Publication accessible in the Journal Applied Energy, issued on 2 February 2019 (<https://doi.org/10.1016/j.apenergy.2019.01.186>).
- Paper 2 (section 4.3): Back to the future: Dynamic full carbon accounting applied to prospective bioenergy scenarios: Publication alongside the Supplementary Material (Appendix

E: SM of Paper 2) accessible in the in International Journal of Life Cycle Assessment, issued on 23 October 2019 (<https://doi.org/10.1007/s11367-019-01695-7>).

Chapter 5 Agriculture: Soil organic carbon modelling: focuses on agricultural systems and dynamic soil organic carbon modelling of dead biomass from energy crops of annual and perennial species by means of the approaches: net primary productivity, carbon fractioning and partitioning. It aims at further improving upstream modelling of carbon releases to the atmosphere from the soil and land uses with potential sequestration profiles. The modelling approach delivers one published papers and one unpublished manuscript:

- Paper 3 (section 5.2): Modelling dynamic soil organic carbon flows of annual and perennial energy crops to inform energy-transport policy scenarios in France. Publication alongside the Supplementary Material informing on SOC modelling and data estimates (Appendix F: SM of Paper 3) accessible in the Journal Science of the Total Environment, issued on 23 November 2019 (<https://doi.org/10.1016/j.scitotenv.2019.135278>).
- Manuscript 2 (section 5.3): Model integration of oil palm production and consumption in the chemical industry and different pathway scenarios; including specification on dynamic oil palm models (Appendix G: SM of Manuscript).

Chapter 6 Discussion: elements of dynamic carbon cycle modelling: provides a synthesis and discussion of the main findings and results involving implementation challenges and uncertainties.

Chapter 7 Conclusions and directions for further research: summarises and concludes on the lessons learned and additionally provides directions for further research not elaborated in this work.

Chapter 2:

Literature review: From static to dynamic carbon modelling

2 Literature review: From static to dynamic carbon modelling

2.1 Chapter context

The purpose of this Chapter is to provide a detailed literature review on the state of the art of the research topic: from static to dynamic carbon modelling approaches for climate change impact assessment in the context of life cycle assessment tools. It does not focus on the underlying biomass-related sciences (e.g. forestry, agronomy, soil science), but on the state of the art of carbon modelling in environmental impact assessment.

The review draws on background information concerning the climate system and perturbation of the net energy balance, key drivers and policy interventions, further providing details on the universally used static methods from the Intergovernmental Panel on Climate Change (section 2.2). Moreover, it introduces to the life cycle thinking concept, the LCA framework, main LCA modelling approaches and generally existing limitations (section 2.3), as well as the state of the art of assessment approaches associated with the lacking temporal consideration in current assessment methods (section 2.4), and methodological developments towards alternative metrics (section 2.5). Finally, it provides an extended overview of existing modelling approaches for dynamic carbon accounting from different disciplines and applications in LCA; thus linking biogenic carbon, soil carbon, and land use with climate change impact (section 2.6.3).

2.2 Climate system and climate change mitigation strategies

2.2.1 Net global energy balance

The Earth climate system, as defined by Baede et al. (2001), is an “interactive system [...] forced or influenced by various external forcing mechanisms, the most important of which is the Sun, [and] the direct effect of human activities [...]”. The net radiation balance (or net energy balance) of the Earth climate system is defined by the rate of energy exchange per unit area, expressed in watts per square meters [$\text{W}\cdot\text{m}^{-2}$].

The net global energy balance accounts for the incoming solar radiation of about $342 \text{ W}\cdot\text{m}^{-2}$ minus about one third that is directly reflected back by clouds, the atmosphere and aerosols without reaching the Earth’s surface and the outgoing radiation of about $235 \text{ W}\cdot\text{m}^{-2}$ from long-waved thermal infrared radiation, sensible heat and evapotranspiration (Cubasch et al., 2013), as illustrated in Fig. 2-1. Some of the thermal radiation is absorbed and re-emitted by the atmospheric greenhouse gases (GHG). The atmospheric GHGs are known as external forcing compounds/agents, which are responsible for the **natural greenhouse gas effect**, warming up the Earth’s surface at a mean temperature of 14 degree Celsius.

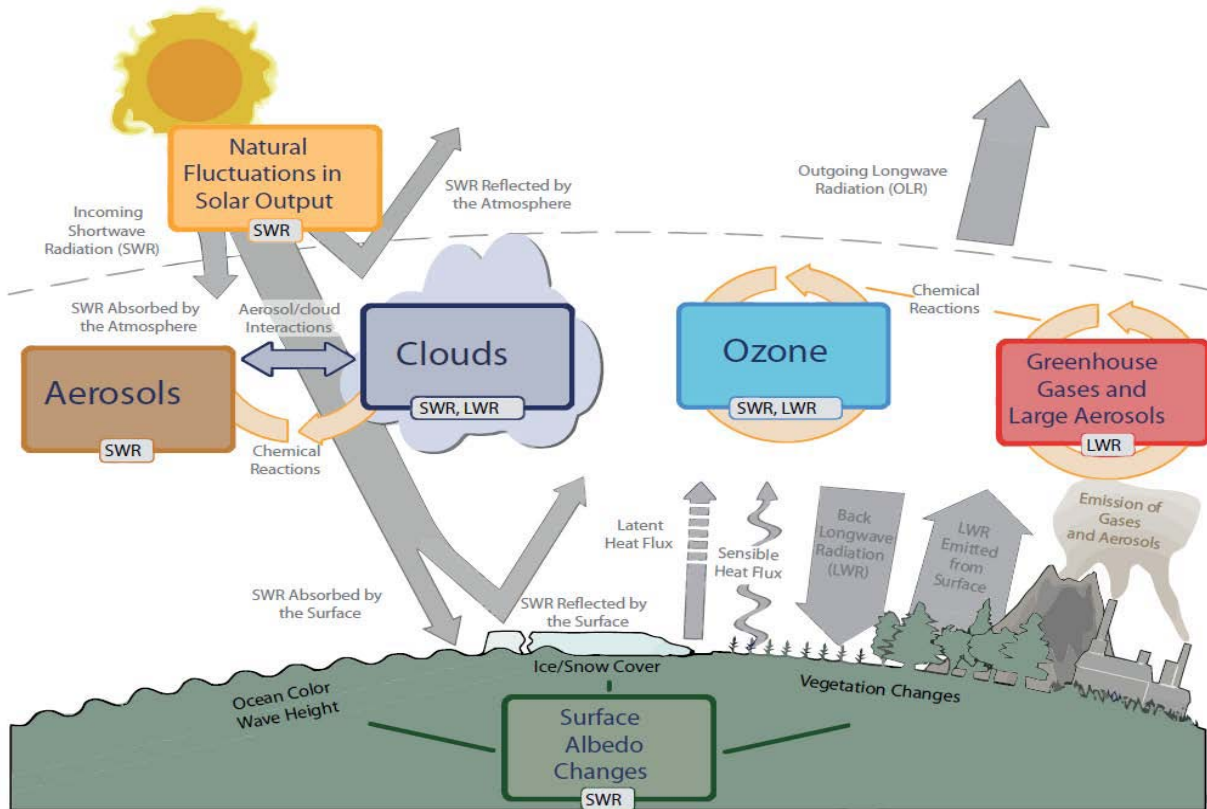

Fig. 2-1: Estimate of the Earth's annual and global mean energy balance. Source: (Cubasch et al. 2013, IPCC AR5, Chapter 1)

Changes in the net radiation balance are referred to as **radiative forcing (RF)** (Forster et al., 2007). Increased concentrations of the external forcing compounds in the atmosphere are one of the major drivers of radiative forcing, and the amount of substances determine the magnitude of the impact given by the atmospheric concentration and the turnover time, i.e. the residence time in the atmosphere (IPCC, 2013a).

The external climate forcing compounds can have **global or local climate effects**, depending on their **atmospheric lifetimes**, as differentiated in Fig. 2-2. The most abundant forcing compounds in the atmosphere are the **Well-Mixed GHGs (WMGHG)** with atmospheric lifetimes greater than one year and therefore distributed globally. The most dominant well-mixed GHGs are: water vapour (H₂O), carbon dioxide (CO₂), methane (CH₄), nitrous oxide (N₂O), chlorofluorocarbons (CFCs) and hydrofluorocarbons (HFCs). The relative impacts of the emission of these substances due to human activities (e.g. combustion) are assessed by means of the Global Warming Potential (GWP) or Global Temperature Potential (GTP) metrics (Myhre et al. 2013a, IPCC AR5, Chapter 8), further detailed in section 2.2.5.

Other anthropogenic drivers of radiative forcing are the **Near-Term Climate Forcers (NTCF)**, which have atmospheric lifetimes less than one year, and **biogeophysical forcers**, which have regional or local climate effects. Near-term forcing compounds include, for instance, carbon monoxide (CO),

nitrogen oxides (NO_x), sulphur oxides (SO_x), non-well mixed methane (CH₄), volatile organic compounds (VOCs), black carbon, organic carbon, water vapour (H₂O), aerosols and ozone (O₃) precursors. The biogeophysical forcings refer to land surface cover changes (e.g. surface albedo change).

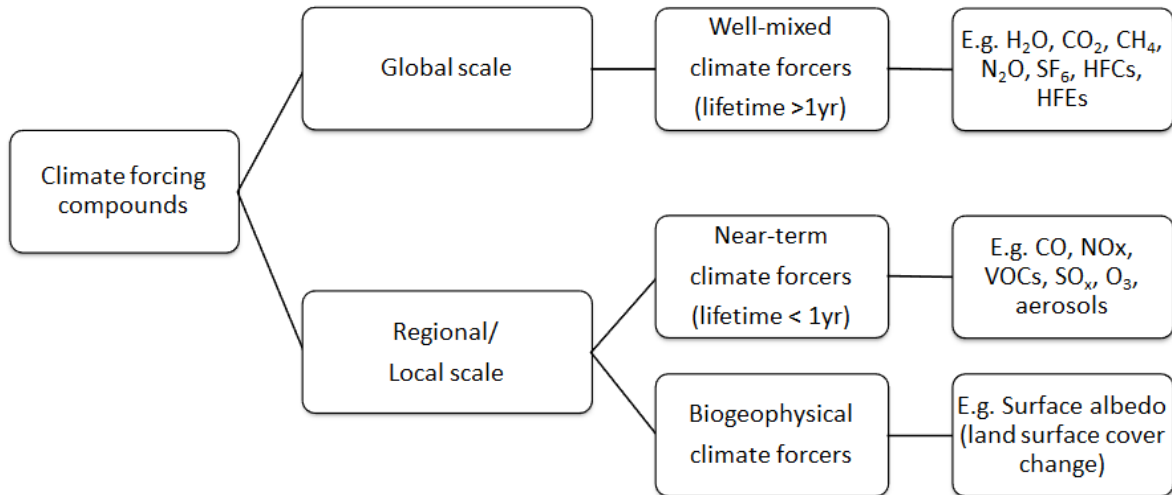

Fig. 2-2: Climate forcing compounds at global and local scales. Source: adapted from Levasseur et al. (2016), and Cherubini et al. (2016)

Forcing drivers have warming (positive) or cooling (negative) feedback mechanisms, depending on the capacity of the driver to absorb or reflect radiation. For instance, the emissions of WMGHGs have warming effects. Other substances such as aerosols (e.g. dust from volcanos) have cooling effects due to their capacity to reflect back the incoming radiation. Positive RF values lead to warming of the Earth climate system and vice-versa for negative RF (Cubasch et al., 2013).

From last measurements in 2011, the RF was estimated at +2.3 W·m⁻² (uncertainty range: 1.1 to 3.3 W·m⁻²) (IPCC, 2013a). The perturbation on the net energy balance is driven by anthropogenic activities, as confirmed with high certainty by climate scientists, and further detailed in the next section.

2.2.2 Key drivers of and main contributing sectors to climate change

CO₂ is the world's dominant radiative forcing driver, accounting for almost 80% of all anthropogenic GHG emissions (EPA, 2017). Main drivers of CO₂ emissions are fossil fuel combustion, deforestation and other land-use changes (Forster et al., 2007; IPCC, 2013a). Other dominant non-CO₂ emissions derive from agricultural activities such as CH₄ (e.g. enteric fermentation rice production) and N₂O (e.g. mineral fertilisers).

The net global GHG emission share (in reference to the year 2010) by the main economic sectors are shortly introduced, as follows (EPA, 2017):

- Electricity and heat production (25% share): electricity and heat consumed in the industry and building sectors. These sectors are the principal consumer of oil, natural gas and coal with over 40% of the primary energy share.
- Agriculture, Forestry, and Other Land Use (24%): includes agricultural crop cultivation, livestock and deforestation.
- Industry (21%): includes the manufacturing and construction industry, as well as on-site energy generation, combustion and transformation processes (chemical, metal and mineral/cement); and excludes waste management activities and other energy uses.
- Transport (14%): emissions are associated with the fossil fuel combustion (mainly gasoline and diesel) for road, rail, air, and marine transportation.
- Building (6.4%): accounts for energy generation and combustion within households, commerce and institutes for heating or cooking.
- Other energy sectors (9.6%): accounts for indirect emissions not associated with heat and electricity (e.g. fuel extraction, refining, processing, and transportation).

The main source of GHG emissions is linked with energy consumption. The latest global statistical energy review (BP, 2018) reported that the year 2017 accounted for the highest mean global primary energy consumption since 2013 from 1.2% up to 2.2% growth rate, with China being the largest consumer. About 60% of the growth is associated mainly with natural gas and renewable energy use, particularly wind and solar power. The per million tonnes oil equivalent (mtoe) amount of primary energy consumed in the world is about 13.5 Kmtoe.

Fig. 2-3 shows the global primary energy consumed per fuel source in the year 2017 here compared to France. Oil (4622 mtoe) is the main fuel consumed in most regions of the world, followed by natural gas (3156 mtoe) and coal (3732 mtoe). France's main fuel source is nuclear energy (90 mtoe), oil (79 mtoe) and natural gas (39 mtoe) (BP, 2018).

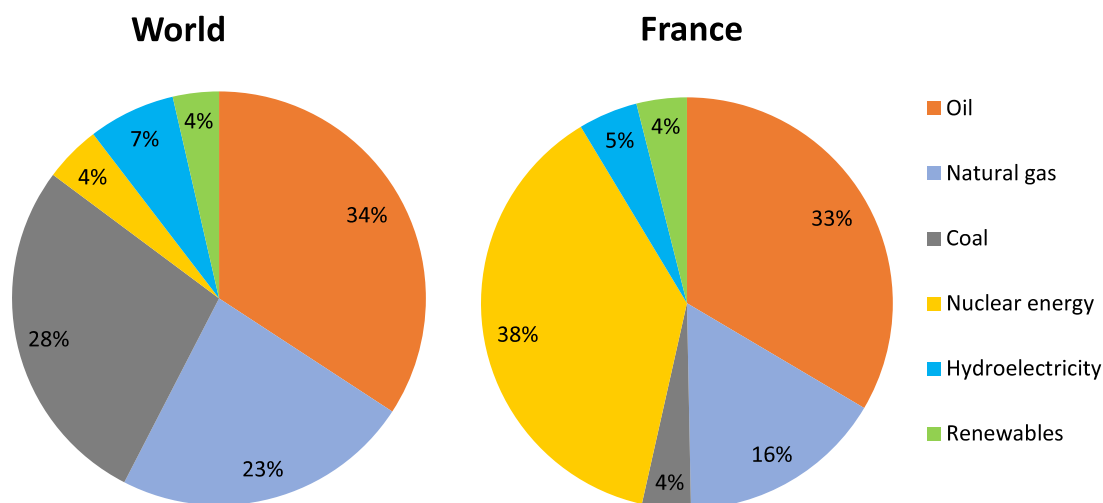

Fig. 2-3. Global primary energy consumption by fuel source compared to France's in the year 2017. Source: (BP, 2018)

The EU-28 GHG inventories are treated by the European Environment Agency (EEA) in partnership with the European Statistical System (Eurostat, 2019). The sectoral representation of EU GHG emissions is based on fuel combustion in energy (electricity and heat), transport, buildings (households, commerce and institutes) and industry (manufacturing and construction) sectors. Almost 80% of the EU GHG emissions are due to fuel combustion, as shown in Fig. 2-4. Other sectors, not related to fuel combustion, involve sub-sectors from industrial processes and product uses, agricultural activities, and waste management. The remaining 2% derive from fugitive emissions associated with leakage, for instance, from fuel storage tanks.

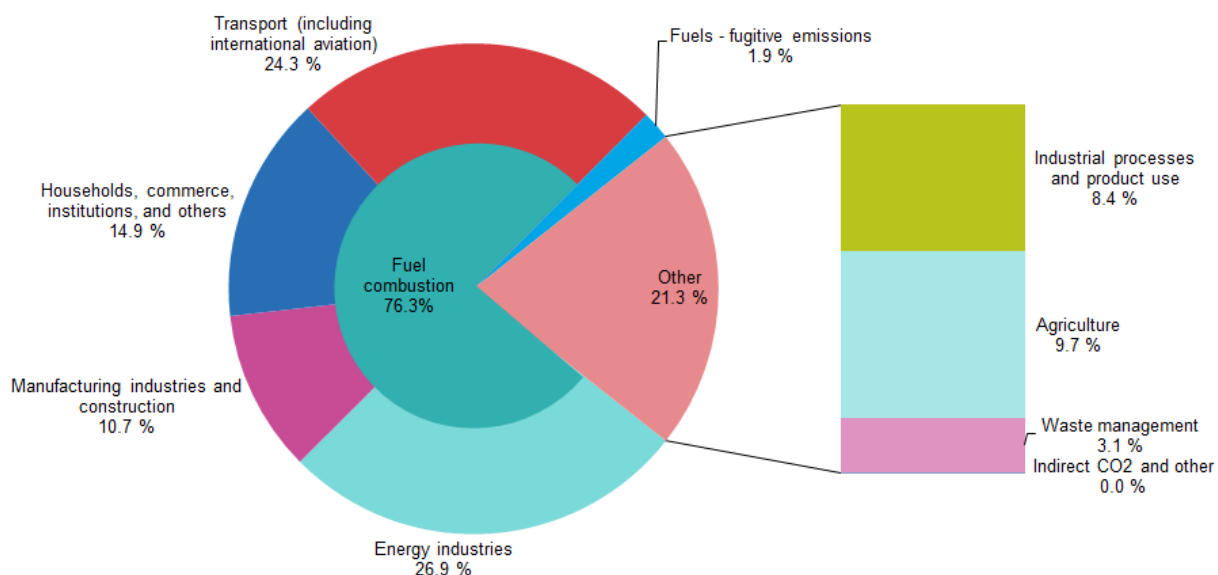

Fig. 2-4. Greenhouse gas emissions by IPCC sector of the EU-28 in the year 2016. Source: (Eurostat, 2019)

From 1990 to 2013, EU-28 GHG emissions have generally decreased in most of the sectors (Eurostat, 2019). It is attributable to changes in the energy mix, reducing fuel combustion and improving energy

efficiency. However, the transport sector has increased by 26% due to lacking efficiency improvements and minimal shift towards renewable energy carriers, compared to other sectors. Major sources of GHG emissions in other sectors derived from the sub-sector product use relating with refrigeration and air conditioning (substituting ozone depleting fluorinated gases).

In France, GHG emissions from fuel combustion account for about 70%. The transport sector is the main contributor with almost 30%, followed by the building, agricultural and industry sectors (all with contributions of around 20%) (SDES, 2019).

The land-use, land-use change and forestry (LULUCF) sector is not included in the EU-28 GHG inventories, because it is considered to be a carbon sink/stock, due to negative emissions from CO₂ removals from the atmosphere and storage in the vegetation (biosphere). In the international Paris Climate Agreement, forestry has been considered to contribute to about 25% of climate mitigation targets by 2030 (Grassi et al., 2017). Consequently, since 2018 LULUCF also forms part of the 2030 EU Climate and Energy Framework, as a climate change mitigation strategy, demanding EU Member States to compensate land-use emissions by and equivalent CO₂ removal within the same LULUCF sector (e.g. cropland, grassland, forestry).

Anthropogenic GHG emissions and the growing need to reduce them is a **global concern**, setting international climate targets and mitigation mechanisms since the early 90s, shortly introduced in the next section.

2.2.3 Climate policy context and mitigation initiatives

The warming of Earth surface temperature is unquestionable, as the evidence from observations and measurements by climate scientists shows.

At international level, the United Nations Framework Convention on Climate Change (UNFCCC) was ratified in 1994, from Earth Summit agreements in Rio de Janeiro. The convention formulated binding climate targets and operational rules under the Kyoto Protocol and Marrakesh Accords, respectively (UNFCCC, 2014). The main objective of the convention is to “stabilize atmospheric concentrations of GHGs at a level that will prevent dangerous interference with the climate system” (UNFCCC, 2008), and thus deal with **climate change mitigation** (reduce GHG emissions) and **adaptation** (anticipate and prevent damages). Sustainable consumption and production towards **low-carbon economies** is an essential component of the mitigation efforts.

The Conference of the Parties (COP) is the ultimate decision-making body, responsible for the effective implementation of the convention agreements. Moreover, the Paris Agreement, adopted in 2015, formulates climate targets aiming at not surpassing the 2°C limit and further encourages reductions to 1.5°C mean temperature levels (UNFCCC, 2018). Therefore, GHG emissions must stop

rising until 2020 and need to be reduced by 60% until 2050, in reference to 2010 levels (EC, 2018a). Therefore, the second UNFCCC commitment period was initiated from 2013 to 2020.

Annex I Parties are committed to the global climate agreements under the development of national climate policies and they can voluntarily engage in the Kyoto mechanisms, namely: Certified Emission Reduction (trade emission units among the Annex I Parties), Joint Implementation (JI: credit for net carbon removal projects in another Annex I Party) and Clean Development Mechanism (CDM: afforestation and reforestation projects within the LULUCF sector, or emission reduction projects in developing countries), including renewable energy projects in non-Annex I Parties (IPCC, 2000; UNFCCC, 2019). New market mechanisms are envisioned to replace CDM and JI after 2020.

At EU level, the Climate and Energy Framework sets the binding multiannual climate targets up to the year 2050 towards competitive low-carbon economy (EC, 2018a). The 2020 targets encompass reduction of GHG emissions and increase the share of renewable energy and energy efficiency, each by 20% (also referred to as the 20'-20'-20' targets). The 2030 targets increase these objectives to 40% GHG reductions, 27% of renewable-energy and energy efficiency share. The GHG emissions should further be reduced by 80% to 95% until 2050.

Some examples related to the EU legislation for the implementation of the given climate targets are listed below (EC, 2019):

- Energy Efficiency (Directive 2012/27/EU): efficiency improvements envisioned, for instance, through refurbishing public buildings, by applying industrial energy audits and management systems, energy efficiency obligations schemes, developing smart power grids, etc.
- Renewable Energy (Directive 2009/28/EC): implementation of alternative energy carriers such as wind, solar or biomass to attain renewable energy share of 20% in the final energy consumption by 2020, with 10% transport fuels from renewable sources.
- Biofuel Directive (Directive 2003/30/EC): targeting at substituting fossil-based fuels, as the transport accounts for one of the main contributing sectors to climate change.
- EU Emissions Trading System (EU-ETS, Directive 2018/410/EU): allowing an international trading market (carbon pricing system) under a limited number of emissions allowances.
- Non-ETS sectors (Effort Sharing Regulation): sectors not covered by the EU-ETS involving housing, agriculture, waste and transport (except air transportation means).
- Low carbon technologies (no Directive): development of carbon capture and storage (CCS) or carbon capture and utilisation (CCU) technologies for power stations, steel mills, and cement factories.

At national levels, action roadmaps formulate the climate targets of each EU Member State. For instance, the 2015 French National Low-Carbon Strategy aims at reducing GHG emissions by 40% in

2030 and by 75% in 2050 compared to 1990 levels (MTES, 2017). The strategic implementations focus the climate targets on the **Circular Economy** and **Decarbonisation** concepts of the energy mix share (electricity and heat), as well as use of renewable energy, clean technologies, and biomass-based materials.

At sectoral level, the French Transition for Green Growth Act, for instance, further formulates targets for the transport sector being the principal contributor, accounting for one third of the national net GHG balance. Potentials for offsetting national GHG emissions by 15 to 20% have been recognised for the forest-timber-biomass sector due to carbon sequestration in forestry, substitution and carbon storage in wood materials, as well as energy recovery from wood-to-waste initiatives (MTES, 2015).

A large number of mitigation initiatives have been launched within the EU to meet the climate targets. Particularly, in the bioenergy context, the EU Industrial Bioenergy Initiative (EIBI, 2019), as well as certification schemes of bioenergy/biofuels, introduced the consideration of **sustainability criteria** (food security, protection of biodiversity and ecosystems, minimisation of land use and land use change impacts), further promoting (i.e. double crediting) advanced biofuels (Scarlat et al., 2015).

Advanced biofuels are increasingly recognised substitutes for fossil fuels, encompassing alternative energy carriers based on dedicated and residual lignocellulosic biomass (e.g. forest wood, short rotation coppice, maize stover, wheat straw, perennial grasses) to displace fossil fuels, reduce land use and food competition with first generation energy crops (Harvey and Pilgrim, 2011; Rathmann et al., 2010; Wise et al., 2009).

Fig. 2-5 shows the biomass use (solid, gaseous and liquid forms) in the electricity, heating and cooling and transport energy share in the European Union, further projected to rise in the year 2020.

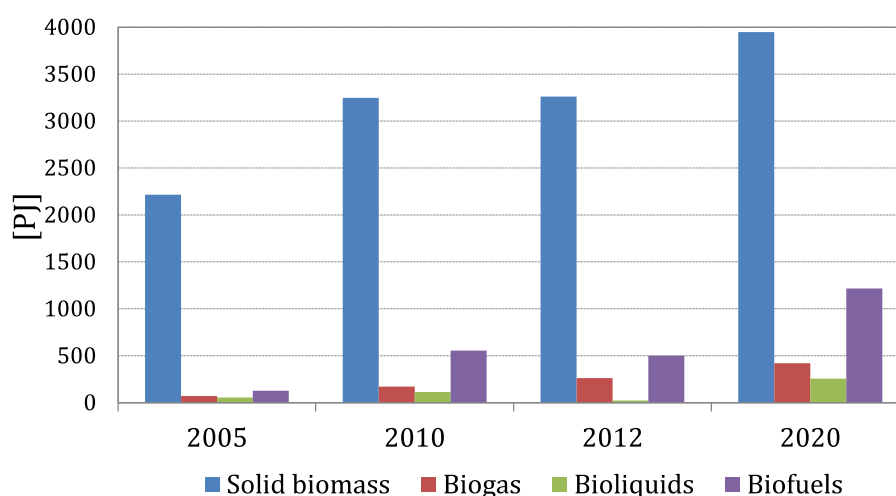

Fig. 2-5. Final EU biomass use in electricity, heating and cooling and transport, with achieved values in 2005-2012 and projections in 2020. Source: Adapted from Scarlat et al., (2015)

Moreover, the “4 per 1000” initiative was proposed in the 21st Conference of the Parties (COP21,, which led to the 2015 Paris Agreement), aiming at increasing carbon stocks in the agricultural and forestry soils, annually by 0.4% (CGIAR, 2018; INRA, 2019; Minasny et al., 2017). The initiative has increasingly gained attention in the last few years.

Further research is needed to estimate the carbon sequestration and storage potentials in the vegetation/crops and in soils. Biomass carbon models and valuing options associated with bioenergy in the EU are currently being reviewed, given the increasing concern that carbon neutrality is an incorrect hypothesis for bioenergy systems (Agostini et al., 2014).

The modelling framework used in policy and science to assess the effects from human activities on Earth climate system is based on the cause-effects approach, further detailed in the next section.

2.2.4 Climate change policy framework

Climate scientist compare the change in atmospheric concentration due to external forcing compounds (e.g. GHG) with historical observations prior to the industrial era (backward-looking approach), or by conducting future scenarios on potential changes (forward-looking approach), to better understand climate change and anthropogenic drivers (Myhre et al., 2013a).

The Intergovernmental Panel on Climate Change (IPCC), created in 1988, serves as a scientific reference by providing information on climate change and related environmental and socio-economic impacts, as well as formulating response strategies (IPCC, 2018). The IPCC Working Group I publishes periodically (every five to six years) the Assessment Reports (AR) containing updated information on the Earth climate system changes.

Several metrics and climate parameters were developed to quantify GHG contributions to climate change based on modelling frameworks along the **cause-effect chain** or so called impact **environmental mechanisms**– involving physical processes of the forcing-responses.

The cause-effect chain, as illustrated in Fig. 2-6, refers to: GHG emissions (or removals) lead to changes in the atmospheric concentration, which has a radiative forcing effect due to larger absorption capabilities of infrared radiation. This radiative forcing causes atmospheric temperature rise (or eventually temperature cooling by negative forcing compounds), affecting the terrestrial surface and water compartments (melting of land ice and permafrost, sea-level rise, changes in precipitation patterns, extreme weather events) leading to flooding, droughts, diseases, malnutrition effects, and ultimately damaging the **areas of protection** (loss of human life and ecosystem species (see Box 2-1)). Droughts alone cause 83% of climate change-induced agricultural losses (FAO, 2018a).

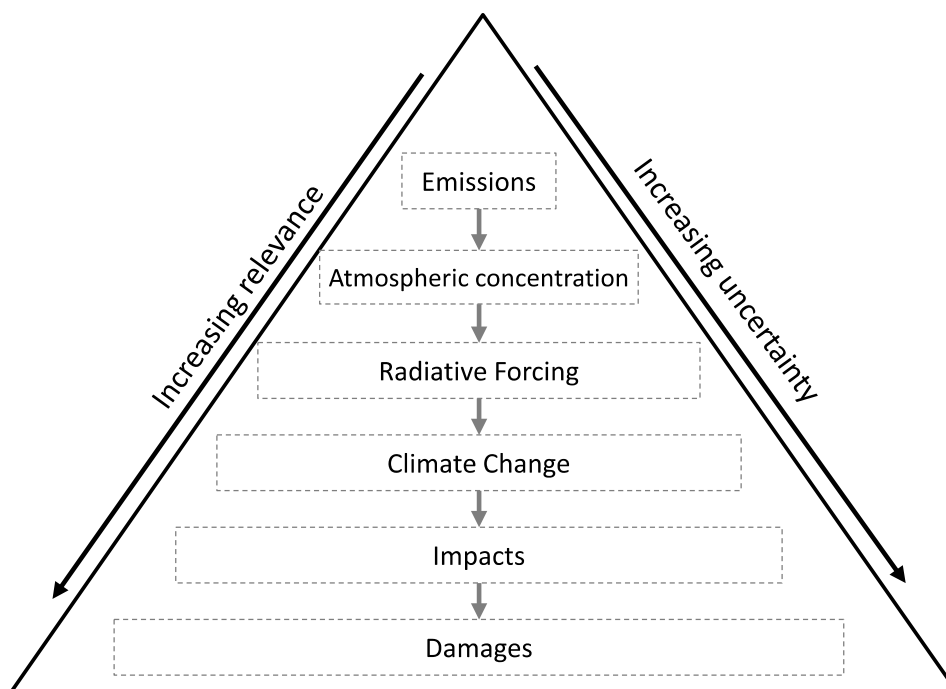

Fig. 2-6: The cause–effect chain from GHG emissions to climate change, impacts and damages. Source: (Myhre et al., 2013a) adapted from Fuglestvedt et al. (2003)

The consequences of radiative forcing, in particular temperature rise, are natural responses of the climate system in order to reach a new radiative equilibrium (Myhre et al., 2013a). The adjustment response at the stratospheric level is much faster (extended to a few months), whereas at the tropospheric-surface level the thermal transfer capacity of the ocean pool has a long response time (Baede et al., 2001) .

Policy relevancy and mitigation strategies increase further downwards the chain (Fig. 2-6) by linking emissions to societal and ecosystem impacts and finally to economic damage (e.g. welfare loss) (Fuglestvedt et al., 2003; Shine et al., 2005).

Quantifying these effects and damages, however, increase the uncertainty, as a higher number of assumptions and models are used. Some uncertainties relate, for instance, with background conditions of atmospheric concentrations held constant, indirect effects from chemical processes (e.g. ozone), quantification of carbon-cycle dynamics, radiative efficiencies and lifetimes of forcing compounds, as well as response timescales on temperature change (Plattner et al., 2009).

Yet, the external forcing compounds are not the only elements causing changes in the net radiative equilibrium, as different processes and interactions among the system components of the global carbon cycle are dynamic and complex. It means that there is no simple proportional relationship between the cause and effect of these non-linear processes (IPCC 2013, Glossary, Annex III).

The two main radiative forcing metrics, namely the Global Warming Potential (GWP) and Global Temperature change Potential (GTP), whose values are reported and updated periodically by the IPCC, are introduced in the next section. The latter was recently included in the Assessment Report 5 of the IPCC (referred to as IPCC AR5) (Myhre et al., 2013a), although it was long discussed among climate scientists (Shine et al., 2005).

Box 2-1. Areas of protection

The terminology “Areas of Protection (AoP)” is used in Life Cycle Assessment (introduced in the section 2.3). AoP are safeguard subjects of the cause–effect chain/impact pathways, defined as: human health, ecosystem quality/natural environment and biotic/natural resources and ecosystem services (Rosenbaum et al., 2018). Impacts on AoP are quantified through damage indicators, also referred to as endpoint indicators. Fig. 2-7 shows how the elementary flows from the GHG inventories are linked in a sequence of environmental mechanisms from midpoint to endpoints indicators (loss of human life and ecosystem damage due to climate change).

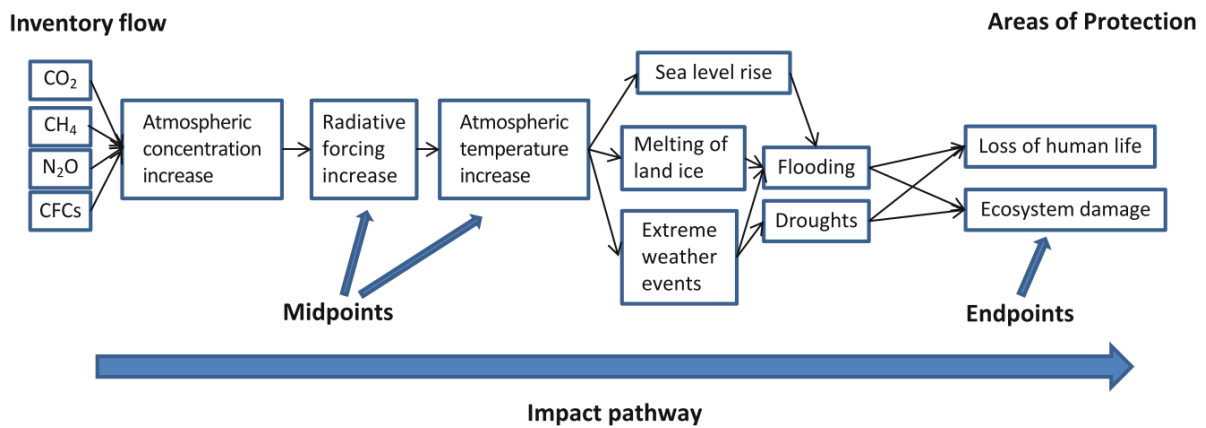

Fig. 2-7. Simplified impact pathways for climate change linking elementary flows for the inventory to the areas of protection. Source: (Hauschild and Huijbregts 2015, p. 9)

2.2.5 IPCC climate metrics used in policy and tools

This section will introduce and compare the Global Warming Potential (GWP) and the Global Temperature change Potential (GTP) metrics.

Global warming potential (GWP) metric

The GWP metric relies on the radiative forcing (RF) concept, which expresses the perturbation on the Earth energy balance due to external changes (see section 2.2.1). The GWP equivalency factors are the integrals of the GHG effect on radiative forcing over the Time Horizons (TH) 20 and 100 years, whereas 100-year TH is the most common one. The emission factors over the 500-year TH have been removed in the IPCC AR5 due to the weight of integrated uncertainties for long-integration periods.

The TH has been defined as “the length of time over which impacts of climate forcings are integrated for cumulative metrics, or the number of years into the future at which an instantaneous metric is evaluated” (Levasseur et al., 2016).

The GWP metric (Eq. 2-1), is given by the absolute global warming potential (aGWP) of an atmospheric gas of interest (*i*) relative to the aGWP of the CO₂ reference gas. The relative difference allows expressing all assessed atmospheric GHG emission in a common unit [i.e. in kg CO₂-eq·kg⁻¹] (IPCC, 1990; Joos et al., 2013):

$$GWP_i(TH) = \frac{aGWP_i(TH)}{aGWP_{CO_2}(TH)} \quad \text{Eq. 2-1}$$

The $aGWP_i$ of non-CO₂ emissions (Eq. 2-2) is the time-integrated RF of a pulse emission of this compound over a fixed TH. The RF is a function of the radiative efficiency (a_i) in watts per square meter and per ppm or ppb of concentration [$W \cdot m^{-2} \cdot ppm^{-1}$ or $W \cdot m^{-2} \cdot ppb^{-1}$] and the atmospheric first-order decay function $C_i(t)$ per unit increase of the atmospheric concentration of compound *i*:

$$aGWP_i(TH) = \int_0^{TH} RF_i(TH) dt = \int_0^{TH} a_i \times [C_i(t)] dt = a_i \tau [1 - \exp(-t/\tau_i)] \quad \text{Eq. 2-2}$$

The $aGWP_{CO_2}$ (Eq. 2-3) of the reference CO₂ gas is a sum of the same analytical forms (Forster et al., 2007), with a radiative efficiency a_{CO_2} (Eq. 2-4) of $1.37 \times 10^{-5} W \cdot m^{-2} \cdot ppb^{-1}$ (Myhre et al., 2013b), and atmospheric decay of CO₂ following a pulse emission by means of the impulse response function IRF_{CO_2} (Eq. 2-5) (Joos and Bruno, 1996).

The IRF_{CO_2} (Eq. 2-5) predicts the decay of CO₂ in the atmosphere as a non-zero asymptote (i.e. the integral goes from zero to infinity), determining the evolution of the atmospheric abundance, whereas an initial CO₂ fraction remains always in the atmosphere. The function defines the re-distribution of the atmospheric CO₂ given by the equilibrium mechanisms of the global carbon cycle (Archer et al., 1997), which is based on the global Bern carbon cycle model, the pulse magnitude and the atmospheric CO₂ background concentration.

$$aGWP_{CO_2} = \int_0^{TH} RF_{CO_2}(t) dt = \int_0^{TH} a_{CO_2} \times [IRF_{CO_2}(t)] dt \quad \text{Eq. 2-3}$$

$$a_{CO_2} = 5.35 \ln \left(\frac{[CO_2^*]}{[CO_2]} \right) \quad \text{Eq. 2-4}$$

$$IRF_r(t) = a_0 + \sum_{i=1}^{l=n} a_x e^{(-t/\tau_i)} \quad \{for\ 0 \leq t \leq 1000\ years\} \quad \text{Eq. 2-5}$$

where in a_{CO_2} the numerator (CO_2^*) represents the atmospheric CO_2 concentration after a small perturbation of 1ppm and the denominator (CO_2) the background CO_2 concentration (compared to the remaining atmospheric CO_2 fraction of the pre-industrial era) estimated in the year 2011 at 430 ppm (± 340 to 520 ppm uncertainty range); in the IRF_{CO_2} the amplitude a_0 (asymptotic airborne fraction) describes the fraction of CO_2 remaining in the atmosphere and the other amplitudes a_x the relative capacity of the other carbon sinks (Joos et al., 2013), with coefficient a_x [unitless]: $a_0 = 0.2173$; $a_1 = 0.2240$; $a_2 = 0.2824$; $a_3 = 0.276$, and respective time constants τ_x [years]: $\tau_1 = 394.4$; $\tau_2 = 36.54$; $\tau_3 = 4.304$.

Global Temperature change Potential (GTP) metric

More recently, a temperature-based metric, the Global Temperature change Potential (GTP), has gained recognition as a metric further down the cause-effect chain (Allen et al., 2016; Cherubini et al., 2016; Shine et al., 2005). The GTP metric was included in the IPCC AR5 (Myhre et al., 2013a), providing equivalency factors for the THs 20, 50 and 100 years.

The GTP is to some extent based on the RF concept due to the response of the climate system to temperature change (Shine et al., 2005). The analytical formulation (Eq. 2-6, Eq. 2-7 and Eq. 2-8) is similar to that of the GWP metric, in which the absolute global mean temperature change $aGTP_i$ of a gas of interest (i) is relative to the absolute global mean temperature change $aGTP_{CO_2}$ of a reference gas (CO_2), to express all assessed GHG emissions in a common unit [$kg\ CO_2\text{-eq}\cdot kg^{-1}$].

$$GTP_i(TH) = \frac{aGTP_i(t)}{aGTP_{CO_2}(t)} = \frac{\Delta T_i(t)}{\Delta T_{CO_2}(t)} \quad \text{Eq. 2-6}$$

$$GTP_i(TH) = \int_0^H RF_i(t) \times R_T(TH - t) dt \quad \text{Eq. 2-7}$$

$$R_T(t) = \sum_{j=1}^M \frac{C_j}{d_j} \exp^{-t/d_j} \quad \text{Eq. 2-8}$$

where R_T is the climate response to a pulse emission, described by the sum of exponentials, C_j the components of the climate sensitivity and d_j the response time, with the coefficients C_j [$in\ W\cdot m^{-2}$]: $C_1 = 0.631$, $C_2 = 0.429$, and response time d_j [$in\ years$]: $d_1 = 8.4$ and $d_2 = 409.5$.

Comparison of IPCC metrics

Table 2.1 compares atmospheric lifetimes of the three main GHGs (CO_2 , CH_4 and N_2O) and both GWP and GTP factors over their respective THs. A complete list of the lifetimes and equivalency factors of different GHGs are published in the IPCC (2013), AR5, Chapter 2.

Table 2.1: Atmospheric lifetime, GWP and GTP factors of three main climate forcers

GHGs	lifetime	GWP		GTP		
		20 years	100 years	20 years	50 years	100 years
CO ₂	*	1	1	1	1	1
CH ₄ , non-fossil	12.4	84	28	67	14	4
N ₂ O	114	264	265	277	282	234

* CO₂ response function is based on a series of coefficients and time scales (see Eq. 2-5) from carbon cycle feedbacks of the Bern carbon model and updated background concentration.

Source: (Myhre et al. 2013b, IPCC AR5, Chapter 8)

The main difference between GWP and GTP is that the former represents the **cumulative impact** of the time-integrated RF over a fixed TH, and the later the **instantaneous difference** in mean temperature change at a specific year (future reference point in time); both in response to a pulse emission relative to that of the CO₂ gas.

The cumulative GWP metric considers short-lived gases over the entire TH, as an integral sum of all instantaneous values. This metric is referred to as having the capacity to “remember short-lived gases” (Levasseur et al., 2016). Consequently, all radiative forcing effects occurring after the TH have zero weight. On the other hand, the GTP represents the instantaneous effects with “no memory capacity of short-lived gases” (Fuglestedt et al., 2010; Myhre et al., 2013a). The GTP approach is constrained to only one specific year, the warming for previous and subsequent years have a zero weight (Tol et al., 2012).

In such context, the GTP provides a better time-relation between the emission pulse and the mean temperature change of the Earth climate system (physical relevance of the climate system response and climate sensitivity). According to Shine et al. (2005, 2007) the GTP metric may be used to develop future climate scenarios with regard to the remaining time before overstepping the climate tipping points.

Sophisticated environmental assessment frameworks, such as the Life Cycle Assessment (LCA) and related software tools (e.g. SimaPro or Gabi) use the GWP emission factors to quantify the potential climate change impacts or carbon footprints from products and services. However, only a few LCA studies have applied the GTP metric (Cherubini et al., 2013; Ericsson et al., 2013; Giuntoli et al., 2015; Porsö et al., 2018)

2.3 Life cycle assessment: concept and framework

The LCA methodology has continuously evolved and gained increasing recognition over the last two decades as a framework for analysing the potential environmental impacts of products (here referred to goods and services), initially focusing on the industry sector and further also involving the

agricultural, food and bio-based sectors. The LCA framework support decision making within and beyond the company boundaries in the context of Life Cycle Thinking (<https://www.lifecycleinitiative.org/>) towards sustainable consumption and production (Sonnemann et al., 2017).

This section will provide an overview of the theoretical foundation and conceptualisation of LCA and international initiatives, as well as details on the operationalisation and limitations of modelling approaches.

2.3.1 Life cycle thinking and management conceptualisation

LCA is also known as the **cradle-to-grave approach** that conducts a “detailed account of all resources consumed and emissions associated to a specific product along its whole life cycle” (ISO, 2006a, 2006b). It quantifies all the flows extracted from and disposed to the environment throughout the product’s life cycle phases: raw material extraction, manufacturing, use, end-of-life treatment (i.e. waste treatment by means of recycling, reuse or recovery of materials) and final disposal (Fig. 2-8); including transportation in all phases (Čuček et al., 2012; Guinée et al., 2011).

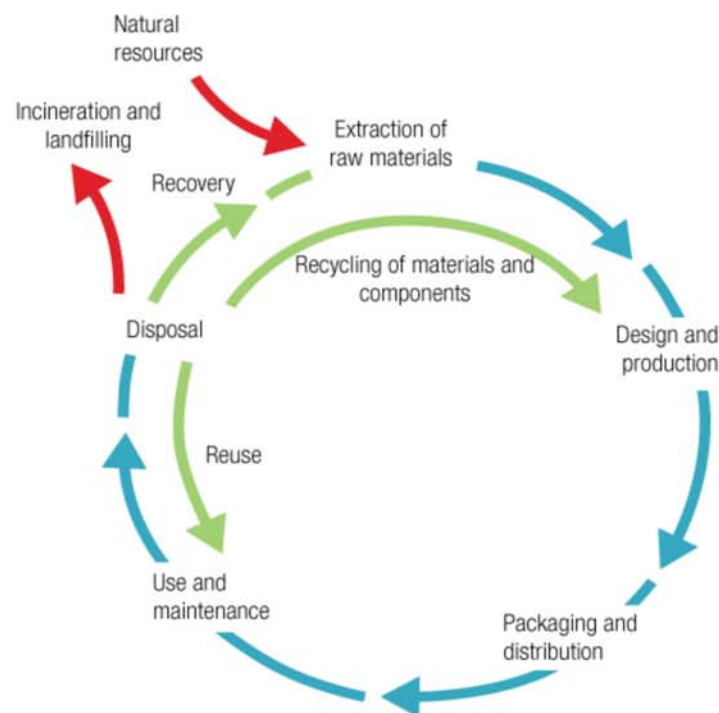

Fig. 2-8: Life cycle thinking of a product with closing the loop (recycling, reuse, recovery). Source: (UN Environment/SETAC, 2006)

At the international level, the Society of Environmental Toxicology and Chemistry (SETAC) launched together with the UN Environment Programme a **Life Cycle Initiative** enabling the dissemination of **Life Cycle Thinking** (LCT) and **Life Cycle Management** (LCM) (Sonnemann and Valdivia, 2013). LCT is a concept based on the pollution prevention and cleaner production

principles, taking into account processes outside the company's boundaries (Jolliet et al., 2005; UNEP/SETAC, 2005). LCM is a flexible and integrated framework that systematically implements the LCT at the management level, comparable with the concepts of continuous improvement: Quality Management System (ISO 9000 family) and Environmental Management (ISO 14000) in the frame of the Plan-Do-Check-Act approach.

At the EU level, the **Product Environmental Footprint Category Rules** (PEFCRs) and **Organisation Environmental Footprint Sector Rules** (OEFSRs) are ongoing initiatives of the European Commission (EC) and the Joint Research Centre (JRC) (EC, 2018b), consisting of a selection of methods for estimating environmental impacts under the LCA framework, towards a homogenisation of the life cycle impact assessment in Europe. The initiative aims at enhancing international cooperation and coordination concerning development of methods and data accessibility of different life cycle approaches. A number of pilot projects under PEFCR are being carried out by several private companies and research institutions for polishing and refining PEFCR Guidelines. It represent one of various EU initiatives aimed to further standardise and homogenise LCA in Europe (EC-JRC, 2013; EC, 2015).

Ongoing LCA framework developments include life cycle costing (LCC) and social LCA (sLCA), which have emerged since the 1980s and 1990s, respectively. An upcoming assessment method towards the three dimensions of sustainability is the life cycle sustainability assessment (LCSA = LCA + LCC + sLCA), is still facing implementation challenges (Klöppfer, 2003; Sala et al., 2012a; Wood and Hertwich, 2012; Zamagni et al., 2013).

2.3.2 The standardised framework

The standardised LCA framework by the International Organisation for Standardisation (ISO, 2006a, 2006b), ISO 14040/44, enhances the credibility and supports a consistent application of the LCA methodology. The framework encompasses four phases, as illustrated in Fig. 2-9 and subsequently explained.

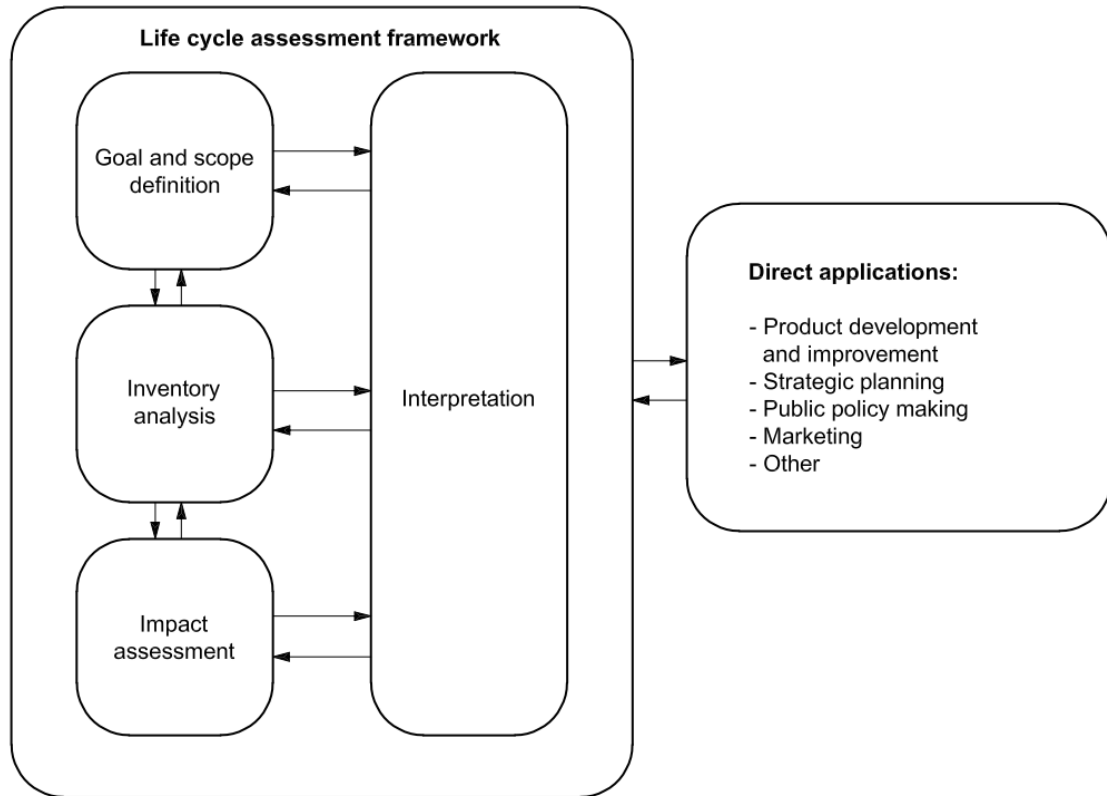

Fig. 2-9: LCA stages and direct applications. Source: (ISO, 2006a)

Goal and scope definition: Phase 1, requires a detailed description of the product system, defining the purpose of the study (e.g. individual or comparative assessment, public or private/internal use, attributional or consequential perspectives (see 2.3.3), the technical specification of the studied system and the product alternatives (system boundaries, reference flow and functional unit), and specifies several decisions on the practical implementation of the LCA, for instance, concerning the collection of primary or secondary data, data assumptions and limitations, the use of accounting approaches/models (referring to phase 2) as well as the selection of the impact categories, metrics/indicators or characterization models (referring to phase 3).

Life Cycle Inventory (LCI): Phase 2, initiates the inventory development of substance masses of the predefined product system and processes by an extended data collection on energy and resource inputs (e.g. water, raw materials) as well as waste/emissions (to air, water and soil compartments) outputs. The mass flows are usually illustrated in a flow chart, visualising the system boundaries of the study and supply chain activities, including allocation specifications of multifunctional unit processes.

Life cycle Impact Assessment (LCIA): Phase 3, assigns all aggregated inventory results to one or several impact categories and translates them into potential impacts and/or damages per functional unit (characterisation). This step involves classifying all substances from different processes, according to the impact categories to which they contribute, adding up and multiplying them by the corresponding characterisation factors (CFs). The characterisation profile represents the environmental performances of the product. Grouping, weighting or normalisation of the impacts can be included optionally.

Interpretation: Phase 4, summarises and evaluates the results by referring to the goal and scope, LCI and LCIA phases. Conclusions and recommendations for decision-makers can be formulated, for instance, in policy development, labelling of products, etc.

Various LCIA methods are available, such as the ReCiPe method (Huijbregts et al., 2016), referring to midpoint (potential impacts) and endpoint (damages to the three AoP) indicators along the impact pathway (see example in Box 2-1). ReCiPe 2016 is an LCIA method deriving from two of the most widely used methods in LCA: Ecoindicator99 (Goedkoop and Spriemsma, 2001) and CML (Guinée et al., 2001). Other LCIA methods include, for instance, the Japanese LIME, IMPACT World+, LC-IMPACT or IMPACT 2002+, thoroughly described in Rosenbaum et al. (2018).

Although the LCA methodology addresses several impact indicators, this dissertation refers only to the climate change impact category, similar to carbon footprinting concerning the life cycle perspective (Fig. 2-10).

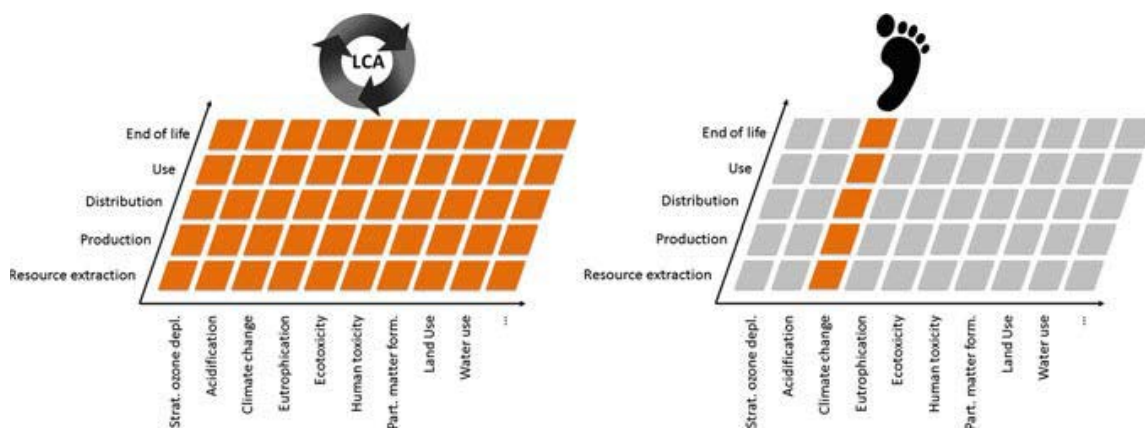

Fig. 2-10. Difference in scope and completeness between LCA and carbon footprint, yet both applying the life cycle perspective. Source: (Rosenbaum et al. 2018, Chapter 10)

LCA results provide useful information on a product's environmental performance/profiles enabling comparisons to alternative products by means of the functional unit (Klöpffer, 2008). The holistic assessment of each life cycle step enables identifying hotspots and thus avoids problem shifting along the supply chains (Čuček et al., 2012). Hotspot identification can lead, for instance, to redesigning products and processes (e.g. eco-design) in a manufacturing unit to improve the environmental

performance of a product (Rebitzer et al., 2004). However, the LCA methodology also faces drawbacks and limitations, described in section 2.3.4.

2.3.3 Main modelling approaches

There are two main analytical modelling approaches in LCA: **attributional and consequential**, defined as follows:

- Attributional LCA (ALCA) is an approach, assessing the potential environmental impacts, directly related with process and resource (material and energy) flows of a product's life cycle, using mostly averaged data (Brander et al., 2009), without the considering any market changes or other indirect effects. The assessment intends to respond to the question “how are things (pollutants, resources, and exchanges among processes) flowing within the chosen temporal window?” (Curran et al., 2005) or more precisely “what are the potential environmental life cycle impacts of a product system (e.g. 1kW of electricity at grid in France in 2006)?” (Frischknecht and Stucki, 2010).
- Consequential LCA (CLCA) is a forward-looking approach, expanding the system boundary by including casual economic market effects, which alter the relative demand of a product (e.g. price increase, transformation in land use) or casual environmental effects (e.g. emissions increase) to assess the consequences/ effects of a change or how a flow changes in response to a (policy) decision (Brander et al., 2009; UNEP, 2011; Weidema et al., 2018; Zamagni et al., 2012). CLCA responds to the question “what are the consequences of an increased demand of a product system in a specific country (e.g. increased demand of rapeseed in the bioenergy system due to the EU strategy on biofuel)?” (Schmidt, 2010). In other words, CLCA is concerned with determining the effects of changes in material and energy —biophysical— flows that a given life cycle may have on other life cycles, be it downstream or upstream ones (Vázquez-Rowe et al., 2014).

Long-standing debates have been conducted in the LCA community about whether to use attributional or consequential approaches, particularly in specific contexts, such as biomass supply chains of bioenergy systems and land transformation (Brandão et al., 2014; Guinée et al., 2018). The main differences between the two approaches are shortlisted in Table 2.2.

Table 2.2. Main differences between attributional and consequential LCA

	ALCA	CLCA
Goal and scope	Assessment of goods and services	Assessment of a change (buying decision, policy implementation)
Technical system	Energy and material flows physically linked to the product system	Energy and material flows affected by marginal changes

Chapter 2: Literature review: From static to dynamic carbon modelling

Dealing with multifunctionality	Mass, energy or economic allocation	System expansion
Data requirements	Mean data	Marginal data (Site-, process-, product-specific)
Indirect effects	Not considered	Considered (e.g. indirect land use change due to additional use for biofuel production)
Economic effects	Not considered	Considered
Uncertainty sources	From empirical data (production, use and disposal)	From empirical data and assumptions regarding the development of market and society

Source: adapted from Brander et al. (2009); Schweinle et al. (2015)

There is a growing body of literature on the consequential approach, including many applications to the energy, transportation and agricultural sectors (Frischknecht et al., 2016). In these sectors, a key indicator is **land use change**: if a certain amount of land occupation currently devoted to one activity (e.g. food crops) is converted to another activity (e.g. energy crops), the overall demand/supply would be affected in such a way that a) the biofuels would displace an equivalent amount of fossil fuels, while b) another food crop system would have to increase its production (by enhanced productivity/intensification) or an additional land use is required to compensate (elsewhere) for the reduction in food crop production (see also Box 2-11).

Many modelling aspects are taken into consideration in CLCA, such as the magnitude of the change (Ekvall et al., 2016), indirect effects (Schmidt et al., 2015), and the handling of co-products (Weidema, 2000; Weidema and Schmidt, 2010). Regarding the latter, CLCA is characterised by never applying allocation, but always system expansion (often with substitution). Under system expansion, a multi-functional system is treated as a whole, without allocating the overall impacts among the co-products. If substitution is applied to isolate the impacts of a single co-product, the impacts of an alternative system providing the co-products are subtracted from the un-allocated system of interest, leaving the impacts corresponding to the single co-product of interest (Fig. 2-11).

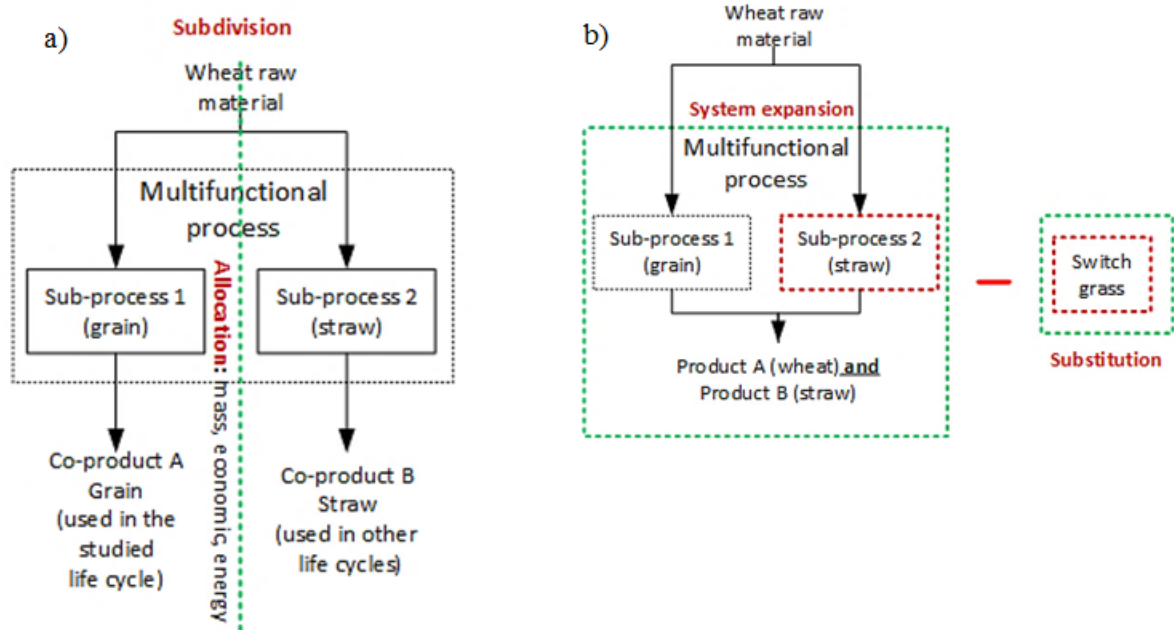

Fig. 2-11. Management of multi-functionality: a) allocation vs. b) system expansion

In recent years, other approaches beyond the well-known ALCA and CLCA have emerged, independently from the ISO standard and guidelines, which have been listed, compared, discussed and classified by Guinée et al., (2018) as “LCA modes” and “X-LCA modes”.

The authors identified that attributional, consequential and decision LCA focus on **existing products** on the market, while anticipatory, prospective and scenario-based LCA focus more on **emerging products** and novel technologies (not yet commercialised).

Moreover, all LCA modes, except attributional, envision future/forward-looking systems, involving possible consequences of changes. The allocation method used is variable for all, but for decision and consequential LCA is always system expansion with substitution.

The authors concluded that rather than focusing on the differences of the modes and models, it might be more appropriate to recognise the “**multi-model multi-paradigm approach**” of LCA studies, which require to explicitly stating the questions and objectives addressed, to justify the use of multi-models.

Table 2.3 provides an overview of these LCA modes and the questions addressed by each.

Table 2.3: Examples of questions addressed by different LCA modes

LCA modes	Description	Questions	Reference
Backcasting LCA	Explores ways from a life cycle perspective to meet normatively defined sustainability levels (planetary boundaries) through adapted affluence (as consumption levels), population growth, and/ or technologies.	What is a region's maximum attainable affluence to meet its planetary boundaries at time t with constant technologies and population? What is the maximum attainable affluence for the EU27 in 2020 and 2050 to meet related EU GHG target?	(Heijungs et al., 2014)
Decision LCA	Based on consequential LCA, but uses information from business-to-business relations (financial and contractual) between economic actors	Which effect does the decision to purchase an additional kWh of electricity have on the electricity market and/or on the environmental impacts? What are the consequences of an increased demand of a certain product system?	(Frischknecht and Stuecki, 2010)
Integrated LCA	Integrates other modelling approaches such as input-output analysis, energy-scenario modelling, and, for example, material flow analysis; for assessing the environmental and resource implications of scenarios for large-scale adoption of climate change mitigation measures.	What are the system-wide life-cycle impacts of a specific energy transition? What are the global life-cycle impacts of a specific energy transition?	(Gibon et al., 2015; Hertwich et al., 2014)
Anticipatory LCA	Forward-looking, non-predictive tool that increases model uncertainty through inclusion of prospective modelling tools, decision theory, and multiple social perspectives.	What are the future environmental burdens associated with an emerging technology for both reasonable and extreme-case scenarios? What are the expected environmental impacts of an emerging product system?	(Wender et al., 2014)
Prospective LCA	Estimates future life cycle impacts by means of scenarios	What are the environmental benefits and impacts of nanosilver T-shirts compared with conventional T-shirts and T-shirts treated with triclosan? What are the expected environmental impacts of an emerging product system?	(Spielmann et al., 2005; Walser et al., 2011)
Scenario-based LCA	Based on scenarios separating three modelling processes, life-cycle modelling, scenario modelling, and valuation modelling	What is the best scenario for improving the life-cycle environmental performance of a car? What are the expected environmental impacts of a certain future scenario of a product system?	(Fukushima and Hirao, 2002)

Source: adapted from Guinée et al. (2018)

2.3.4 General limitations

The LCA methodology is considered as rather mature thanks to a continuous development and refining process over more than three decades (Guinée et al., 2011). Nonetheless, it still features a number of technical problems, data gaps and choice elements, thoroughly discussed in (Reap et al., 2008a, 2008b). Solutions and strategies to overcome some of these issues have been proposed during the last ten years, but certain challenges remain, as shortly introduced in this section:

- The functional unit definition does not fully reflect the studied product system and all its functions. Often, only the primary function of the product is included and both temporal and quality constraints are excluded (Bellon-Maurel et al., 2013; Tyszler et al., 2014).
- The ISO allocation hierarchy poses fundamental theoretical and practical implementation problems, and thus the choice of an allocation approach among co-products is one of the most difficult and often controversial methodological aspects of LCA, because it may dramatically alter the results (Ardente and Cellura, 2012; Ekvall and Finnveden, 2001; Pelletier et al., 2015; Schrijvers et al., 2016; Weidema, 2000).
- Lacking consideration of dynamic features at temporal and spatial scales and of local environmental uniqueness (Jeswani et al., 2010). The information when and where the emissions and pollutants occur on the “temporospatial landscape” (Jolliet et al., 2015) still faces challenges in modelling complex realities linked to wide ranging uncertainties.
- Adaptability to scales beyond the production systems, such as regional/territorial or institutional is still work in progress, but several solutions have been proposed for both regional and spatialised LCA (Avadí et al., 2017; Loiseau et al., 2012; Morais et al., 2016; Mutel and Hellweg, 2009; Nitschelm et al., 2016; Sala et al., 2012b).
- Data gaps, uncertainty and bias regarding aspects such as toxicity (Rosenbaum et al., 2008) and normalisation (Sleeswijk et al., 2008). Pedigree indicators for the data used in LCIs are commonly used (e.g. byecoinvent), and further pedigree-related data protocols have been suggested for primary, secondary and background data management (Henriksson et al., 2013).
- Data uncertainty in particular is a great issue in LCA, and a number of approaches have been developed to address it, propagate it and communicate it (Ciroth et al., 2013; Heijungs and Huijbregts, 2004; Imbeault-Tétreault et al., 2013; Niero et al., 2015; Smith Cooper and Kahn, 2012).
- Other aspects, including the customary exclusion of capital goods without proper analysis (Frischknecht et al., 2007), the implications for application in business (Baitz et al., 2013), and LCA’s use and usability in international supply chains (Freidberg, 2013).

From the above list of shortcomings, this dissertation is concerned with the **temporal limitations in LCA**. While increasingly more studies have addressed spatial limitations, less research has been conducted regarding the temporal dynamics (Collet et al., 2014).

Section 2.4 outlines in more detail the lack of consideration of the time dimension in LCA, and the wide-ranging practical implementation challenges of temporal considerations in LCA methodology.

2.4 Life cycle assessment: temporal limitations

2.4.1 Static/linear computational structure of LCA

The computational structure of LCA (Box 2-2) is a simplified linear approximation of the environmental effects. It refers to the mathematical foundation of the LCA method by Heijungs and Suh (2002) describing a process matrix in a linear space in which all flows —both economic and elementary flows— are multiplied, transposed and inversed. The matrix represents the production system as input and output flows, which scales the impacts to a reference flow, subsequently multiplied by respective characterisation factors.

Consequently, the temporal information a specific emission takes place (e.g. calendar year, sequence, range of time steps) is lost (Hellweg and Frischknecht, 2004; Levasseur et al., 2010a). For this reason, it is commonly stated that the environmental performance of a product results in a “**snapshot in time**” (Bright et al., 2012; Finkbeiner et al., 2013; Heijungs and Suh, 2002; Klöpffer, 2014; Levasseur et al., 2016; Owens, 1997a; Vigon et al., 1993). All flows outside the studied system are held constant.

In the real world, however, the actual effects from product systems are not linear as they might have different time implications and are often a function of the cumulative background concentrations (Finnveden et al., 2009; Hauschild, 2005).

Box 2-2. Computational structure of life cycle assessment

The process matrix (P) (Eq. 2-9) is partitioned in the technology matrix (A) and intervention matrix (B), representing both the economic/technology (exchanging between unit processes) and the elementary/environmental (exchanging with the environment) flows respectively:

$$\mathbf{P} = \begin{matrix} \mathbf{A} \\ \mathbf{B} \end{matrix} \quad \text{Eq. 2-9}$$

The scaling factor (s) is the inverse of the technology matrix (A^{-1}), representing the exchanges between unit processes and the final demand vector (f) of the reference flow (Eq. 2-10):

$$\mathbf{s} = \mathbf{A}^{-1}\mathbf{f} \quad \text{Eq. 2-10}$$

The inventory vector (g) is given by a scaled intervention matrix (B) (Eq. 2-11). The sum of the economic flows is restricted to a mass load aggregation of all unit processes per reference flow. The aggregation ignores the temporal variability of flows.

$$\mathbf{g} = \mathbf{B} \mathbf{A}^{-1}\mathbf{f} \quad \text{Eq. 2-11}$$

Impact vector (h) is given by multiplying the inventory vector with a characterisation matrix (Q) to translate and impact score in a common unit (Eq. 2-12). The impacts are assumed to be linearly proportional to the aggregated emissions.

$$\mathbf{h} = \mathbf{Q} \mathbf{B} \mathbf{A}^{-1}\mathbf{f} \quad \text{Eq. 2-12}$$

2.4.2 Background system modelling and datasets featuring linear coefficients

Generic data sets (e.g. ecoinvent database) provide data for modelling **background systems** (e.g. primary materials, processing machinery, harvesting equipment, infrastructure), and intermediary flows (e.g. raw material extraction, electricity-mix, fuel supply). The unit processes are modelled with constant coefficients describing **linear technology models**. Yet, technology applications for similar processes along the value chains are not always equivalent, due to large variability in technological performance and evolution (Jolliet et al., 2015).

Moreover, according to Heijungs and Suh (2002a), it is required to specifying product processes at the time they are “active”. **Active time** relates, for instance, to waiting times in manufacturing (e.g. between the production of product components and its assembly) or to temporal variability in the energy sector (e.g. changes in the electricity mix), technological performance and innovation (e.g. conversion efficiencies) as well as associated with atmospheric characteristics (e.g. temperature change due to climate change and its effects).

Pinsonnault and colleagues (2014) added temporal information to background and intermediate unit processes of almost one fourth of the ecoinvent v2.2 database and tested the method Enhanced Structure Path Analysis (ESPA)— previously suggested by (Beloin-Saint-Pierre et al., 2014) —to temporally differentiate the inventory flows in accordance to the time-dependent climate change impact category. The test has demonstrated that time sensitive unit processes were associated with wood and biofuels. Other impact categories have not been tested, requiring further research.

2.4.3 Static modelling of elementary flows in LCI

Substances can generate different impacts and damages at different points in time. It means that impacts can vary significantly over time due to complex environmental mechanisms and biogeochemical processes, depending on different parameters, such as, the lifetime of substances, the adaptability or resilience of ecosystems to cope and recover from environmental pressures (Lenzen et al., 2006).

Adding temporal information to **foreground data** requires supplementary data to describe and define the time dependency, sensitivity and relevancy of elementary flows of unit and/or system processes. Collet et al. (2014) previously proposed a method for selecting the time steps, within the whole process network, and defining time-sensitive flows, for which dynamics need to be considered, while others can be approximated by steady-state representations.

Time steps for dynamic modelling can be drawn from **inherent time scales of impact categories** (Collet, 2012; Owens, 1997b); i.e. defining the temporal frequency of emissions (e.g. with daily, monthly or yearly time constraints). LCA methods encompass different impact categories, with

potentially different temporal implications in the modelling, as shown in Fig. 2-12. This dissertation is concerned solely with the climate change category, for which modelling time steps are recommended at annual frequencies (Collet et al., 2014; Levasseur et al., 2010a).

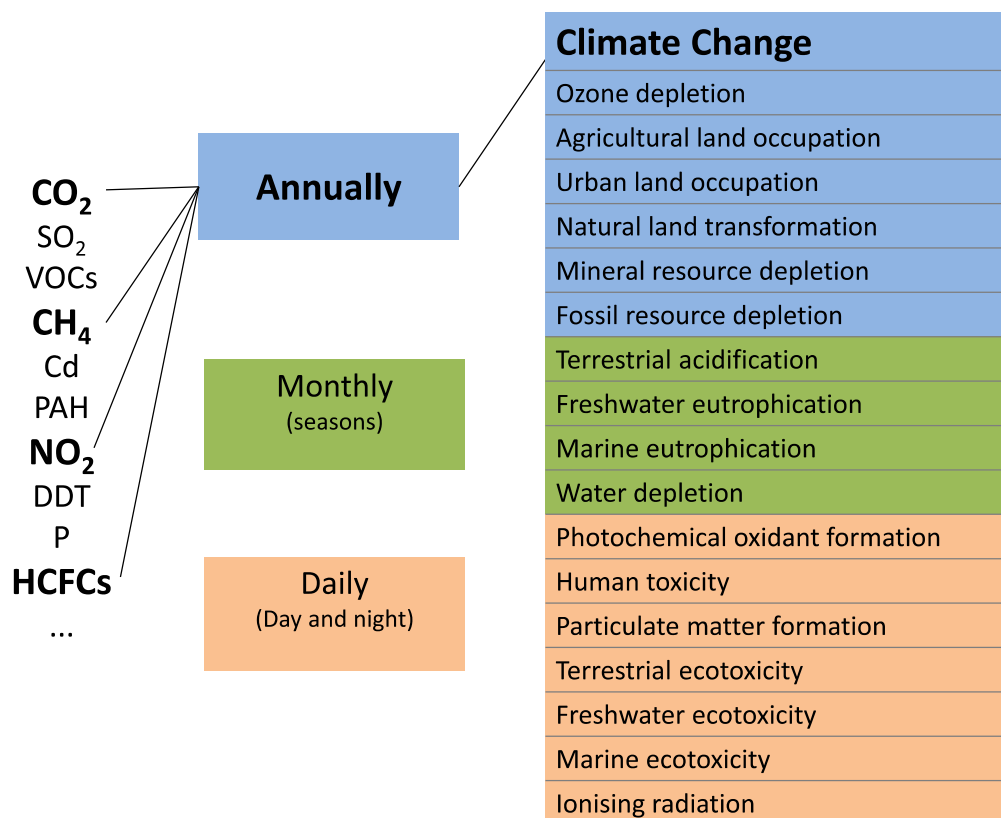

Fig. 2-12. Dynamic time steps of elementary flows inherent to the climate change impact category. Source: adapted from Collet et al. (2014)

Temporal modelling frequencies can also be differentiated, for instance, as “episodic (e.g. once only, land clearing), cyclical (e.g. seasonal water use), stochastic with a certain recurrence interval (e.g. 1 in 20 year waste discharge), or continual” (Lenzen et al. 2006 p.248). Cyclical or seasonal variations and changes, concerning sunlight, temperature and precipitation on the calendar year (e.g. winter vs summer time), might be relevant, for instance, for the impact categories, aquatic eutrophication (Udo de Haes et al., 2002), water scarcity (Boulay et al., 2015), human toxicity (Manneh et al., 2012) and photochemical oxidant formation (Shah and Ries, 2009).

Moreover, Liao et al. (2015) found that the common seeding-to-harvest assessment period in agricultural LCA does not correspond to the actual dynamics of fertilising substances, some of which contribute to eutrophication during the next crop in the rotation.

2.4.4 Time horizon choice in LCIA

Generally, the characterisation of impacts requires an analytical time horizon (TH) for the impact characterisation: either **fixed-finite** (with temporal cut-offs) or **infinite** (steady-state representation).

To date, the choice of a TH remains a wide topic of discussion within the LCA community (Reap et al., 2008c).

The fixed 100-year TH is the most used and recommended in practice for the climate change impact category, but also applied to stratospheric ozone depletion, ionizing radiation and toxicity impact categories, based on the ReCiPe method (Huijbregts et al., 2016). The selection of 100 years is a non-scientific time preference (Reap et al., 2008c; Shine, 2009; Vogtländer et al., 2014), implicitly subjective by and for decision/policy making (Brandão and Levasseur, 2010; Fearnside, 2002), referred to the “middle way” (Shine et al., 2005) between the 20 and 500 years.

Dyckhoff and Kasah (2014) recommended a time dominance criteria approach from decision theory in the context of dynamic LCA to reduce the decision problem on a particular value. The setting of an infinite TH does not solve the temporal issue, as valuable temporal information is lost and in the specific case of biogenic carbon or mitigation projects, carbon sequestration is regarded as a static approach over an infinite TH (Levasseur et al., 2012c).

For this reason, other authors consider choosing a TH as unavoidable (Fearnside, 2002). However, the assessment with a fixed TH does not prevent from assigning the same impact characterisation to all emissions, disregarding the dynamic features of substances and the consequences beyond the selected TH.

The principal aspects challenging the fixed TH are:

- Inconsistency within temporal boundaries: LCI elementary flows (e.g. emissions) can occur at different points in time, potentially creating an inconsistency between the timeframe of the studied product system and the timeframe covered by the impact characterisation (Benoist, 2009). Actual emission releases mostly do not correspond to the chosen TH, as highlighted and demonstrated by several authors (Brandão et al., 2019; Cherubini et al., 2016; Jørgensen and Hauschild, 2013; Kendall et al., 2009; Levasseur et al., 2016, 2010a; O’Hare M. et al., 2009).
- Different THs generate different metric values: the homogenous time-integration of substances with high temporal variations in the characterisation (i.e. linked to the lifetime or fate) may bias the results. For instance, climate forcers have different atmospheric lifetimes (residence time) which can cause important variations in characterisation factors. As an example, the atmospheric lifetime of CH₄ is 12.4 years with characterisation factors [kg CO₂-eq] of 84 for TH 20 years and 28 for TH 100 years (Myhre et al., 2013a) (see section 2.2.5). The climate effect measured through the GWP declines with growing TH, as the denominator is the long-lived CO₂ reference gas. It means that by rising integrals the RF of long-lived climate forcers have higher weight than short-lived ones (Cherubini et al., 2016). The shorter

the TH, the higher is the impact of short-lived gases (Levasseur et al., 2010a). Consequently, the weight of climate forcers with very short atmospheric residence time decreases with increasing TH, and vice versa (Levasseur et al., 2016; O'Hare M. et al., 2009). For toxic substances, Huijbregts et al. (2001) demonstrated that the selection of a fixed TH for assessing metal toxicity potentials results in changes with up to 6.5 orders of magnitude. The high dependency on the TH is given due to long residence times in the fate models, in which the impact increases over time due to metal run-offs and leaching potentials into other aquatic and soil compartments.

- Temporal cut-offs beyond the TH: Implications from substances occurring outside the fixed TH, particularly concerning long-lived products or long-term emissions, are ignored (Hellweg and Frischknecht, 2004). Therefore impacts further shifting into the future (e.g. due to physical storage) are not coherently assessed with the GWP metric.

To reduce inconsistencies with the fixed TH, different approaches have been developed and proposed. For the characterisation of climate change, TH dependent metrics were created based on time-adjusted warming potential factors for various THs and GHG emissions (Kendall, 2012) and time correction factors for amortised CO₂ emissions and fixed THs (Kendall and Price, 2012) (further detailed in section 2.5).

O'Hare and colleagues (2009) defined a conceptual framework to reflect the importance of early emissions and cumulative warming from substitutes of biofuels. For the characterisation of acidification at endpoint level, Van Zelm et al. (2007) proposed the computation of characterisation with various THs.

2.4.5 Temporal boundaries: time preferences

Defining the temporal boundaries of a study, related with the choice of TH, gives a value to time and the accounting process (Levasseur et al., 2010a). Long-standing debates discuss about trade-off between time preferences given to short or long term effects, also linked with the TH choice.

The ReCiPe method (Huijbregts et al., 2016) offers three cultural time perspectives (individualist, hierarchist and egalitarian), each one associated with a different set of assumptions that include TH for each impact category (Box 2-3). The hierarchist perspective, for instance, retains a 100-year-TH for the climate change, stratospheric ozone depletion, ionizing radiation, and toxicity impact categories.

Box 2-3. Cultural perspectives in LCA

Cultural perspectives in LCA refer to different value laden choices about the temporal preferences inherent in impact modelling (Hofstetter et al., 2000). The ReCiPe method (Huijbregts et al., 2016a) provides characterisation factors for different cultural perspectives, introduced as follows:

- Individualist: considers short-term/immediate effects, as the assumptions are optimistic about the

stable natural environment and assume that environmental risks in the distant future can be tackled through technological innovation.

- Hierarchist: seeks scientific consensus between short- and long-term perspectives, and consideration of default models, as it assumes that the natural environment is resilient to some extent.
- Egalitarian: considers long-term effects based on the precautionary thinking and intergenerational equity, assuming that the natural environment is fragile.

In terms of sustainable development and the climate change impact category, temporal cut-offs are two-fold between short- (<100 years) and long-to-infinite- (>100 years) terms, as shown in Fig. 2-13. Short-term perspectives are ethically questioned in terms of intergenerational equity (Hellweg et al., 2003), and long-term perspectives might ignore the pressing issues, such as climate-tipping points, and further shift the burden into the future.

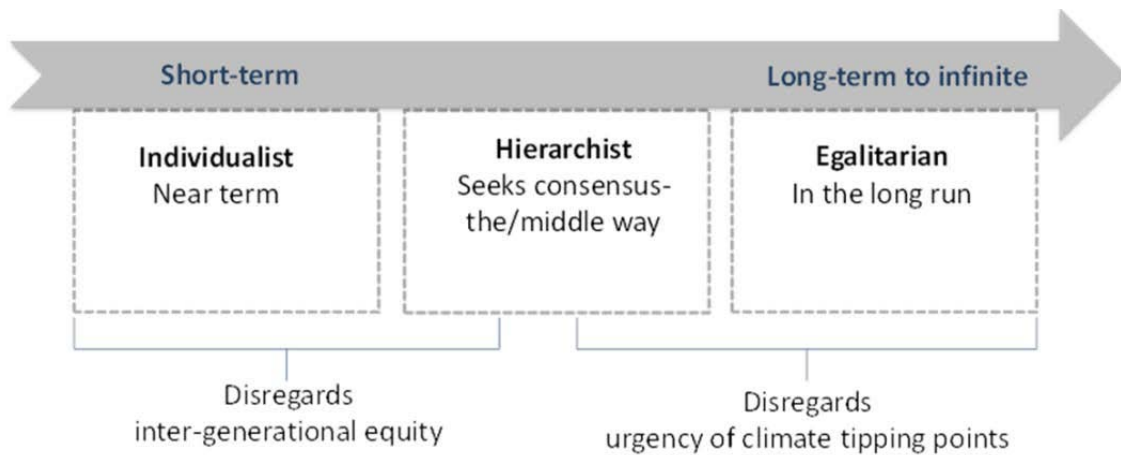

Fig. 2-13: Short- to long-term time preferences by cultural perspectives associated with the climate change

For instance, displacing fossil fuel emissions poses significant challenges, when the future releases are not accounted for. Disregarding long-term effects eventually does not allow crediting temporary storage and emission delays (Brandão and Lévassieur, 2010; Jørgensen et al., 2015). On the one hand, it has been argued that delaying RF due to temporary carbon stocks reduces the cumulative impacts by further postponing the impacts to “buy time” for technological innovation. Thus, valuing biogenic flows in the context of carbon sequestration (e.g. in long-lived products) to offset fossil fuel counterparts remains an important research gap.

Yet, offsetting concerns have been raised by Kirschbaum (2003) with regards to future emissions that may occur at one point in time, for instance, due to instantaneous releases (e.g. combustions). Long-term climate effects from temporary carbon offsetting of delayed emissions may be considerably magnified at some point in the future. The long-term cumulative warming declines over a given TH due to temporal carbon sequestration and storage, however the instantaneous short-term emissions are eventually higher than before the carbon storage.

Moreover, the economic concept of discounting (Box 2-4) has been discussed in the past for LCA applications, to reduce time related **value choices or trade-offs** between the present cause and the future effects (Hellweg et al., 2003). The authors argued that a finite/fixed TH is an implicit form of discounting long-term impacts with a zero discounting rate. Yet, they concluded that discounting in LCA should be applicable only when temporally differentiated data is available, for instance, under consideration of new technology developments.

Yuan et al. (2015) developed a theoretical framework for temporal discounting to overcome overall time implications (temporal homogeneity) due to inventory aggregations in the traditional LCA approach and resulting uncertainties. The framework describes time relevancy in the life cycle phases (as a step-by-step approach) for a temporal differentiation of emission profiles, which are then discounted to a reference time. The approach is similar to the dynamic LCA framework, however the link between the discounting and reference time is missing.

Box 2-4. Time-discounting preferences

The discounting concept is used, for instance, in the context of climate mitigation mechanisms, such as EU carbon trading system and mitigation projects. The method adjusts a future event to a present value by a discount rate (net present value) based on negative exponential decay (Fig. 2-14).

Fearnside (2002a) defined “the importance of time will be expressed in two decisions: time preference weighting (for example by discounting) and choice of a time horizon”. The author argued that discount rate is the most common means for time preference weighting of future events. Rising discount rates (and thus shortening the TH) gives a higher value to time and thus to policy decisions, increasingly considered issue in the context of climate change abatement efforts with temporary or immediate consequences (Fearnside et al., 2000). For climate change impact assessment, it is particularly challenging due to long-term effects and global scale. Given long-term TH, the investment in mitigation is less worth today.

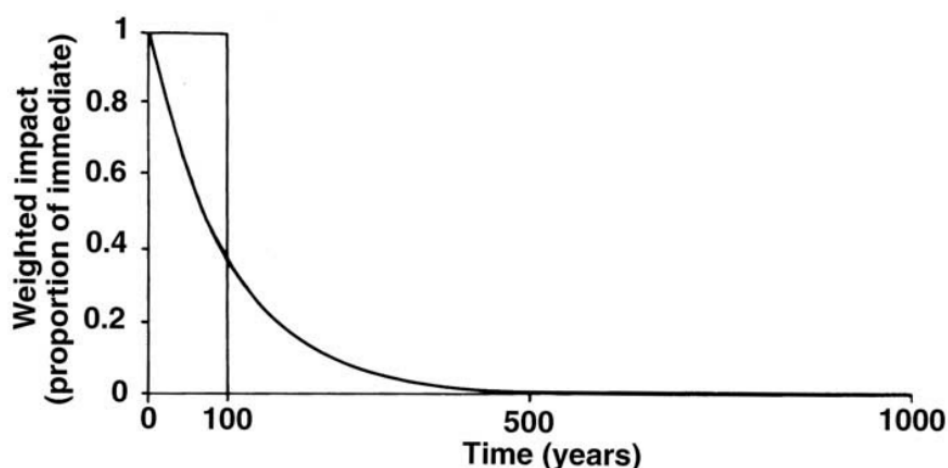

Fig. 2-14. Discount rate equivalent to a time horizon. Source: Fearnside (2002a)

2.4.6 Prospective time horizon and scenario-driven perspectives

Another form of temporal consideration is increasingly performed by means of scenario-driven case studies, particularly regarding time series modelling. For instance, time has been taken into consideration by means of scenario-bound CFs, in water use studies, where each scenario represents a different prospective TH (Núñez et al., 2015).

In the specific context of market penetration or expansion of emerging bioenergy pathways, LCA has been combined with prospective energy system models (e.g. partial-equilibrium/techno-economic models) (see Box 2-5), such as the TIMES model framework, to forecast energy and process pathways under the consideration of constraints (e.g. policy-driven objectives) (Levasseur et al., 2017; Menten et al., 2015; Vázquez-Rowe et al., 2013).

Nonetheless, even when dynamic inventories are built, time is not properly considered, if the impact assessment remains static.

Box 2-5. Energy system models (prospective scenarios)

Energy system models explore technology pathways and the cost of responding to climate targets. The analytical fashion of energy system models are differentiated in three main groups, often relying on historic data (Böhringer and Rutherford, 2008; Hall and Buckley, 2016; Hourcade and Robinson, 1996):

- Top-down models or general equilibrium models, involve macro-economic metrics to analyse economy-wide responses induced by policies. They are referring to pessimistic paradigm.
- Bottom-up models or partial equilibrium models are technologically explicit at system level, involving policy constraints, as well as costs and emissions implications. They are referring to optimistic (engineering) paradigm.
- Hybrid models combine both top-down and bottom-up models or blend features of both into a single integrated model.

Bottom-up models are used to analyse national policies and decarbonisation pathway planning (Hall and Buckley, 2016), many of them based on “perfect-foresight cost-optimizing models” evolving to highly parametrised complex constructions (Trutnevyte, 2016). Commonly known optimistic models are, among others, TIMES/TIAM (Loulou et al., 2016), OSEMoSYS (Howells et al., 2011), MESSAGE (Keppo and Strubegger 2010(Trutnevyte, 2016)), LEAP (Heaps, 2016), and Temoa (Hunter et al., 2013). The approach usually relies on linear programming with the objective of optimising the total costs of the analysed energy system by exploring trade-offs among the standard and emerging technologies of all energy consuming sectors (considered as a whole) (Li and Trutnevyte, 2017; Subramanian et al., 2018).

Recently studies (Cherubini et al., 2016; Levasseur et al., 2016) discussed the shortcomings in LCA concerning climate change impact assessment by using a single GWP metric, for instance, in the context of temporal and spatial variability of substances, climate mitigation and (emerging) bioenergy systems. Methodological developments and proposed methods are further detailed in the next section.

2.5 Methodological developments for climate change in life cycle impact assessment

According to Myhre et al. (2013a, p. 669), “the actual impact on climate depends on both the temporal and spatial structure of the forcing and the rate of response of various portions of the climate system”. It means that climate response depends on time and spatial variations. The UNEP/SETAC (2016) global guidance on impact indicators for LCA (pre-publication review), concluded that no metric is available to inform on the dynamic climate effects, and thus proposed using complementary metrics for different purposes.

A number of research initiatives have contributed to add both spatial and temporal dynamicity to LCA, especially to the climate change impact category.

2.5.1 Spatial-dynamic oriented

Global climate models and methods, such as the GWP and GTP, account for well-mixed GHGs at mostly at global scales, poorly considering short-lived substances (atmospheric residence time <1 year) or the spatial distribution, and thus ignoring most of local or site-specific climate effects (Cherubini et al., 2016; Myhre et al., 2013b). The spatial distribution of emissions (i.e. how the forcing compounds are geographically spread) is difficult to model and quantify due to different climate response patterns. Near-term Climate Forcers (see section 2.2.1) have a close connection to the hydrological cycle, affecting directly cloud properties and water vapour (Myhre et al., 2013a).

Some LCA studies for bioenergy systems have applied methods addressing Near-Term Climate Forcers (e.g. Giuntoli et al. 2015; Giuntoli et al. 2016; Iordan et al. 2016) and more specifically concerning surface albedo effects (changes in surface reflectivity) due to land cover changes (Bright et al., 2012; Cherubini et al., 2012; Holtsmark, 2015). Bright et al. (2012) developed a GWP_{α} metric integrating the albedo effects of forest biofuel systems in LCA.

2.5.2 Climate target oriented

It has also been discussed whether to include approaches relevant to specific climate policy targets (Jørgensen et al., 2014; Kirschbaum, 2014). Target-dependent timeframes have the potential to estimate emissions within the climate change policy frameworks to predict climatic thresholds (temporal peaks) (Cherubini et al., 2016), as proposed by the following metrics:

- Climate tipping point potential (CTP): aims at assessing the atmospheric capacity to receive GHG emissions, defined by a target level (e.g. 450 ppm CO₂-eq.), referred to as the climate tipping point, which is the limiting factor to a global threat (Jørgensen et al., 2014, 2015; Lenton et al., 2008). This metric was developed to make a link between the climate change impact assessment and planetary boundaries concept towards climate policy targets

(Rockström et al., 2009). Thus, CTP considers the timing of an emission occurrence relative to the climate target (so called target time approach).

- Climate-change impact potential (CCIP): proposed by Kirschbaum (2014), aims at supporting climate targets and mitigation efforts allowing the comparison of the marginal GHG effects over 100 years and the impacts from adding a unit pulse emission, based on the setting atmospheric background conditions. Different climate impacts are addressed related with temperature rise, rate of warming and the cumulative warming.

2.5.3 Biogenic carbon oriented

Benoist and Bessou (2018) provided an extensive review and an evaluation on methodological developments in LCA, determining and linking land use and land use change (LULUC) and biogenic carbon flows with climate change, as well as the implications on soil quality, including soil organic carbon (SOC). This summary provides an overview of some of the methods analysed, with particular emphasis on biogenic carbon.

The authors evaluated among the LULUC and climate change methods, the stock-difference and gain-loss approaches in the IPCC Guidelines (IPCC, 2006a), as well as the methods by Müller-Wenk and Brandão (2010), Benoist and Cornillier, (2016), and Schmidinger and Stehfest, (2012). A few major groups were identified linking biogenic carbon with climate change, shown in (Fig. 2-15), and described as follows:

1. IPCC metrics involving GWP and GTP (previously described in section, differentiated by their static (S) and/or dynamic (D) modelling features 2.2.5),
2. Further developments based on the IPCC GWP metric considering the time dimension (e.g. Time-adjusted GWP (Kendall et al., 2009), Dynamic LCA (Levasseur et al., 2010a)), as well as specific to biogenic carbon (e.g. Lashof tonne-year method (Fearnside et al., 2000), GWP_{Bio} (Cherubini et al., 2011a)), soil carbon sequestration (Petersen et al., 2013), and temporary C storage and delayed emissions from the ILCD handbook (EC-JRC, 2010) and PAS 2050 standard (BSI, 2008)),
3. Other non-IPCC based developments, such as Biogenic Assessment Factors (BAF) (EPA, 2014) referring to biogenic stationary emissions, and
4. Carbon sequestration consideration at product level based on global mass balance of forest systems, including land use change correction factors (Vogtländer et al., 2014).

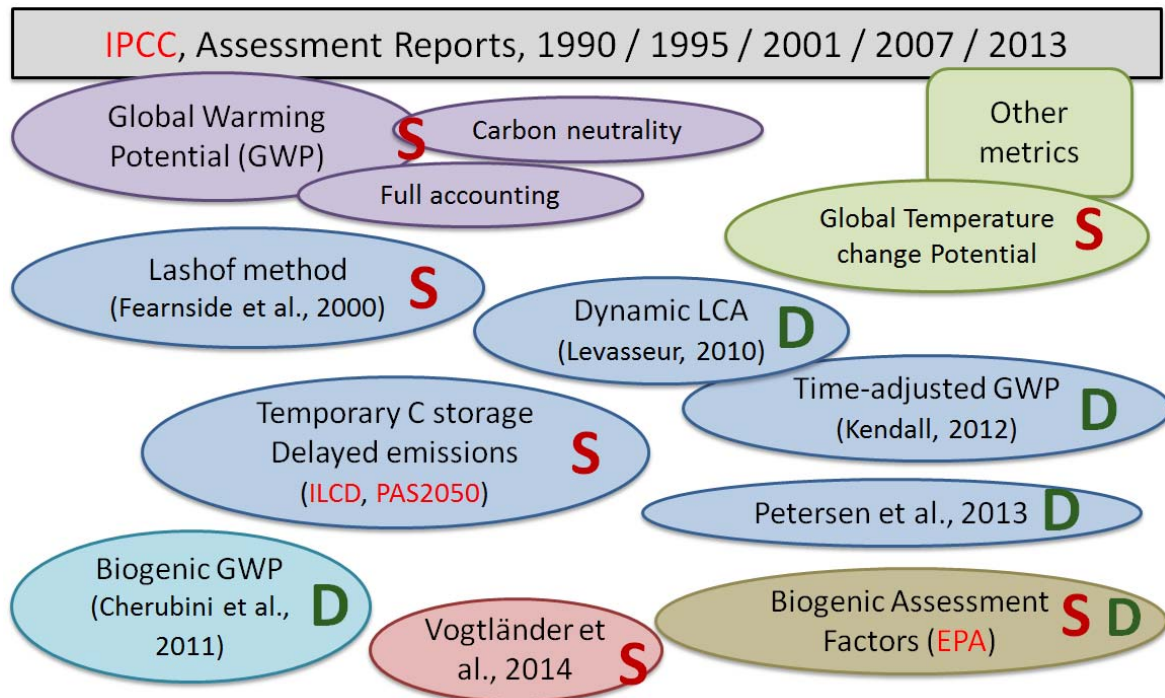

Fig. 2-15. Mapping static (S) and dynamic (D) methods, linking fossil and biogenic carbon, soil organic carbon and climate change. Source: adapted from Benoist and Bessou (2018)

More recently Brandão et al. (2019) described 15 climate change assessment methods, in the specific context of bioenergy systems, most of which are depicted in Fig. 2-15, including among others, Moura Costa and Wilson (2000), Clift and Brandão (2008), and O’Hare et al. (2009).

In this dissertation, climate change oriented methodological LCA developments are grouped based on their consideration of three key aspects: **C_{bio}**, **SOC** and **land use** (methods focusing on land use change are excluded). Most methods are transversal across these three considerations (Fig. 2-16). Some of these methods are discussed in the following sub-sections, regarding their usefulness for modelling C_{bio} and SOC associated with land use in the context of **climate change impacts from bio-sourced materials and energy**.

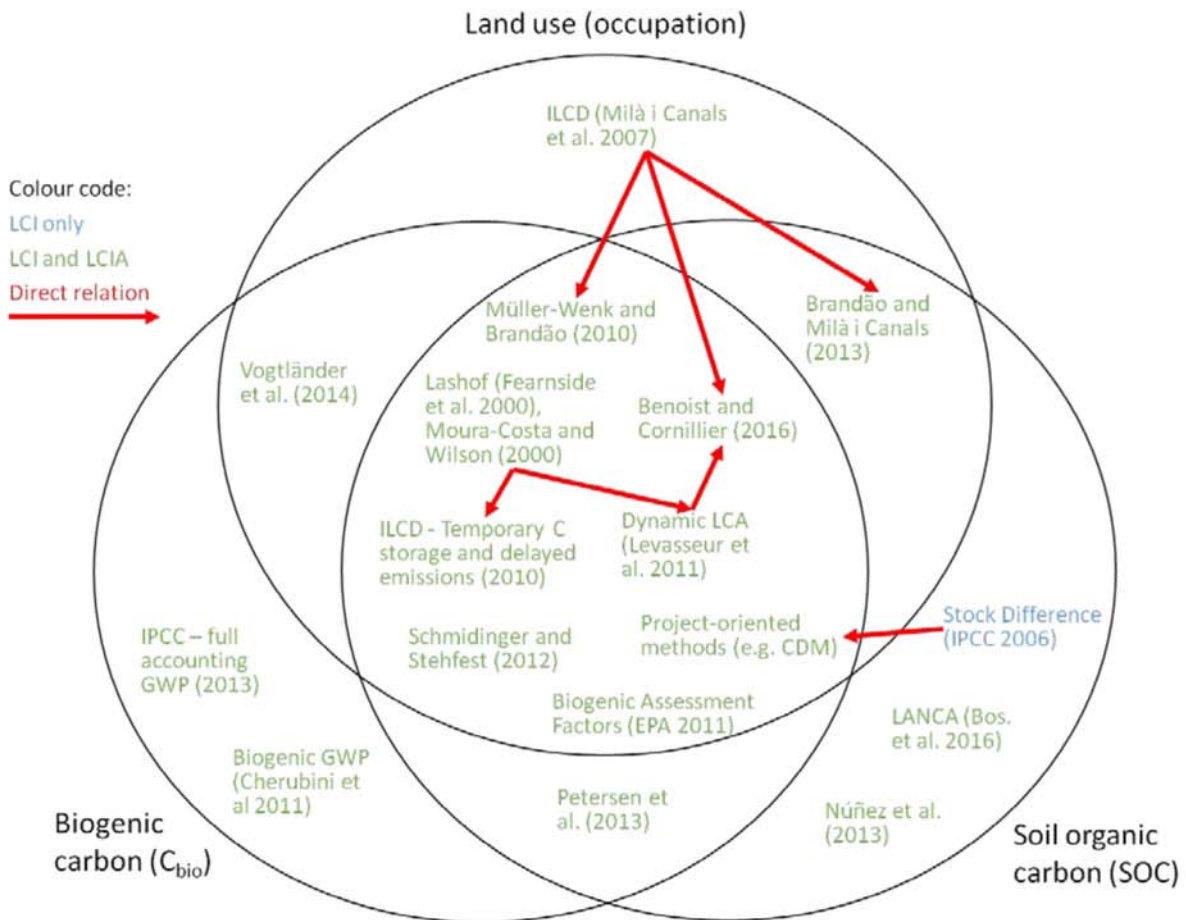

Fig. 2-16. Mapping of methods linking biogenic carbon, soil organic carbon, and land use with climate change. Source: adapted from Benoist and Bessou (2018)

Benoist and Bessou (2018) included in the method evaluations the carbon neutrality and full accounting approaches, recognised in the latest IPCC AR5, as a specific considerations of biogenic carbon compared to fossil carbon (Myhre et al., 2013a). In this dissertation these approaches are considered in the context of carbon modelling to inform LCIs rather than LCIA methods, further described in section 2.6.

The dynamic LCA method by Levasseur et al. (2010), useful in general for biomass-based systems, is discussed separately in section 2.5.6.

2.5.4 Temporary carbon storage in biomaterials

Temporary carbon storage and delayed emissions (at product level): the ILCD handbook (EC-JRC, 2010) and PAS 2050 (BSI, 2008) recommend accounting for temporary carbon storage and emission delays, while the ISO/TS 14067 (ISO, 2013) standards as well as the PEFCF Guidance (EC, 2018c) refer to it optional (further specified in section 2.6.4). It allows accounting the delay of GHG

emissions and crediting its storage over the time C is retained in the anthroposphere/technosphere. The method is applied to fossil and biogenic sources, although the products may have different carbon content ratios (Brandão and Levasseur, 2010).

The emission delay refers to C_{bio} temporally stored in products, thus the carbon is kept in the technosphere. The CO_2 benefit is linearly distributed by means of -1% C accounting per year up to 100 years, in the ILCD handbook implemented as “correction elementary flows”. The TH for accounting is differentiated between short-term (≤ 100 years) and long-term (> 100 years) time perspectives, whereas long-term storage beyond one century is not accounted for, but reported separately. Thus, the approach is restricted to 100-year cut-off period.

Tonne-year approaches (at project level): originally presented in the context of Land-use, Land use change and Forestry (LULUCF) sector, to offsetting fossil fuel CO_2 emissions for the number of years the biogenic carbon is stored in vegetation/biomass. These metrics have also been discussed for the application in LCA (at product level). The Moura-Costa (Moura Costa and Wilson, 2000) and Lashof (Fearnside et al., 2000) approaches are based on cumulative radiative forcing effect (see section 2.2.2) for 1 tonne of pulse CO_2 integrated over 100 years. They assign a benefit per tonne of CO_2 stored over 52-years, given by the area below the CO_2 decay curve in the atmosphere over the residence time of 100 years (Brandão et al., 2019). For Moura-Costa and Wilson, the accounting year of the pulse emission and the storage are equally set at year 0 (t_0), while for the Lashof method the initial storage starts 52 years (t_{52}) after the pulse (t_0). A longer storage period would compensate a pulse emission greater than 1 t CO_2 under the Moura-Costa approach, thus overestimating storage benefits (Brandão and Levasseur, 2010; Levasseur et al., 2012b).

2.5.5 Biogenic and soil-sourced carbon emissions and storage from bioenergy

Biogenic assessment factors (BAF) (at stationary source): proposed by the US Environment Protection Agency EPA (2014) to assess atmospheric contributions of biogenic CO_2 emissions from both production (biomass production and processing) and consumption in stationary sources (biomass combustion, digestion, fermentation or decomposition). The factor [unitless] represents the ratio between the net biogenic CO_2 emissions (associated with biomass production, processing and use in stationary sources) relative to the potential gross emissions (biogenic feedstock carbon at different supply chain stages and the stationary source process). The metric allows assessing biogenic CO_2 emissions based on carbon mass balances.

The BAF factors express the following: exactly offsetting the biogenic CO_2 at stationary source (BAF = 0), contribution of biogenic CO_2 to the atmosphere due to upstream processes (BAF = 1), partially offsetting biogenic CO_2 at stationary source ($0 < \text{BAF} < 1$), fully counterbalanced biogenic CO_2 at stationary source (BAF < 0), net CO_2 increase due to upstream processes (BAF > 1).

Biogenic Global Warming Potential – GWP_{Bio} (at product level): Cherubini and colleagues (2011) developed a biogenic GWP metric (GWP_{Bio}) to assess the biogenic CO_2 flows from biomass-sourced bioenergy systems, as a function of rotation dynamics of any terrestrial aboveground biomass.

The GWP_{Bio} undertakes carbon neutrality assumptions, that is to say, one unit of CO_2 release from biomass combustion equals the same unit of CO_2 removed from the atmosphere during regrowth. However, it considers the RF effects and thus climate change impacts caused by one unit CO_2 pulse emission release from biomass combustion (a) and the time it takes for the same unit of CO_2 , directly after harvest, to be re-sequestered during biomass growth over a given rotation (b), as shown in Fig. 2-17. The rotation assumes even-aged vegetation stands with clear-cut harvest and immediate replantation, where the same unit released will be re-sequestered.

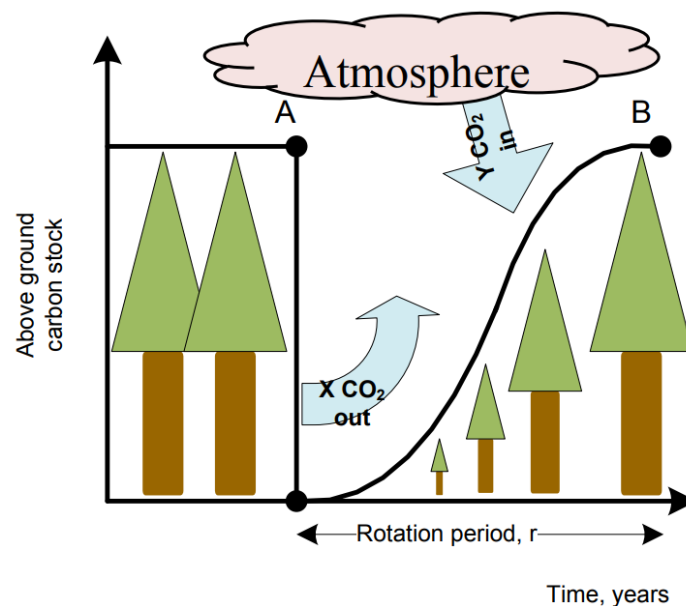

Fig. 2-17: GWP_{Bio} approach with a) clear cut harvest and combustion, and b) immediate regrowth over a full rotation period. Source: Cherubini, 60th LCA forum presentation (2015)

The method incorporates biogenic CO_2 flows from the terrestrial biological pool into GWP calculation — and expresses the absolute contribution of biogenic CO_2 ($aGWP_{BioCO_2}$) (Eq. 2-13) relative to the absolute contribution of fossil-sourced CO_2 ($aGWP_{FossilCO_2}$), formulated with the Impulse Response Function (IRF) previously described in section 2.2.5.

The atmospheric CO_2 decay function $f(t)$ following a pulse emission consists here of a convolution between two functions expressing the rate of biomass regrowth $g(t')$ and the CO_2 removal rate from the atmosphere $\gamma(t)$ from the global carbon cycle, shown in Eq. 2-14.

$$AGWP_{BioCO_2} = \int_0^t \alpha [f(t)] dt \quad \text{Eq. 2-13}$$

$$f(t) = \gamma(t) - \int_0^t g(t') \gamma(t - t') dt' \quad \text{Eq. 2-14}$$

The GWP_{Bio} factors are available over the integration time horizons 20, 100 and 500 years, up to a rotation length of 100 years, depending on the vegetation type. The characterisation factors increase with increasing rotation length (i.e. longer vegetation regrowth cycles). It means that the fast growing species (e.g. annual crops) have lower climate change impacts than biomass species with long rotation lengths (e.g. forest trees).

The GWP_{Bio} has been mentioned in the IPCC AR5 (IPCC, 2013a), highlighting the limitations of the carbon neutrality hypothesis undertaken for C_{bio} flows. However, similar to the IPCC GWP metric (see section 2.2.5), any RF effect beyond the selected TH is neglected. Moreover, the method assumes that harvest activities are performed before the regrowth of the vegetation (Cornillier and Benoist, 2015). Thus, the applicability and robustness of the method needs further research (Benoist and Bessou, 2018).

Soil carbon changes (at product level): Petersen et al. (2013) proposed a dynamic approach to account for possible changes in soil carbon in LCA. The approach combines a process-based soil carbon model (C-Tool) for timing soil-sourced CO_2 releases due to degradation with the CO_2 decay curve (described in the Bern carbon cycle model to determine the CO_2 fraction remaining in the atmosphere over time). The soil C balance demonstrated soil carbon sequestration potentials over 20 years associated with crop residues.

Both GWP_{Bio} and soil carbon changes approaches take into account the temporal aspects of CO_2 releases to the atmosphere and their atmospheric evolution (Bern carbon cycle model). The methods allow accounting for CO_2 emissions from biomass sources in LCA to assess their potential climate change effects. Yet, both methods do not fully represent a dynamic approach with annual frequencies, as the impacts representation is based on a fixed TH.

2.5.6 Dynamic LCA

Various levels of dynamic LCA have been identified in the literature, as summarised in Table 2.4, ranging from fully static to fully dynamic at LCI and LCIA levels.

Table 2.4. Main approaches for C_{bio} modelling and assessment in attributional LCA

	Static LCI and LCIA	Static LCI and LCIA, with credits	Dynamic LCI and Static LCIA	Dynamic LCI and LCIA
Assumption of carbon neutrality	Yes	No	No	No
Assumption of emission at harvest	Yes	No	No	No
Credits for temporary C storage	No	Yes	No: Sequestration and temporary storage are considered in the dynamic LCI	No: Sequestration and temporary storage are considered in the dynamic LCI
Treatment of time in LCI	Aggregated as a pulse emission at time 0	Aggregated as a pulse emission at time 0	Dynamic	Varies: Some approaches use a dynamic LCI, other include time considerations directly in LCIA
Treatment of time in LCIA	Fixed time horizon	Fixed time horizon	Fixed time horizon	Fixed time endpoint

Source: Breton et al. (2018)

A systematic comparison between static and dynamic LCA framework performed by Su et al. (2019) is shown in Table 2.5, based on four main dynamic assessment elements, namely consumption, basic inventory datasets, characterisation factors and weighting factors, which were formalised in the context of dynamic LCA methodology for buildings.

Table 2.5. Operational difference between static and dynamic LCA

Assessment element	Static LCA	Dynamic LCA
Consumption	Consumption over the entire life cycle stays at current (evaluation point) level	Consumption varies over time
Basic inventory datasets	Static basic inventory datasets at the evaluation point are adopted in the assessment	Temporal basic inventory datasets are adopted in the assessment
Characterisation factors	Assumes that emissions throughout the whole life cycle occur at a single point in time	Characterization factors are time-dependent, and vary with the moment when the pollutant is emitted
Weighting factors	Weighting factors remain constant during the life cycle	Weighting factors change over time

Source: Su et al. (2019)

Time-dependent radiative forcing or dynamic LCA (at product level) is a dynamic LCIA method for the climate change impact category developed by Levasseur et al. (2010). It is based on the radiative forcing concept, like the IPCC GWP metric (see previous section 2.2.5), however with

integration boundaries set for one-year time steps. The dynCO₂ tool for dynamic impact assessment has been developed by the authors for the implementation of the dynamic impact assessment (Box 2-6)

The method considers a pulse emission that occurred t_n years before the RF. For instance, the RF (or Global warming impact – GWI) occurring at year 40 is caused by an emission released at year 40, the emission is multiplied by a dynamic characterisation factor of year 40. If the RF occurring at year 60 is caused by an emission released in year 20, the emission is multiplied by the dynamic characterisation factor of year 20, and so forth, exemplarily illustrated in Acronyms: E = Emission, CF = characterisation factors equivalent to emission factor in LCA language, GWI = Global Warming Impact

Fig. 2-18.

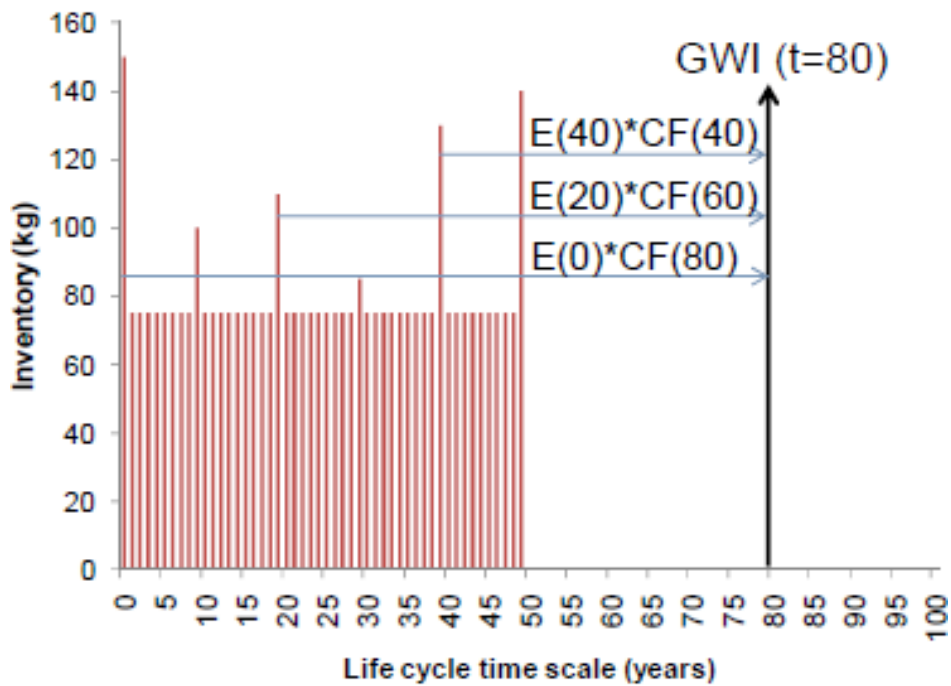

Acronyms: E = Emission, CF = characterisation factors equivalent to emission factor in LCA language, GWI = Global Warming Impact

Fig. 2-18. Time-dependent radiative forcing approach. Source: Annie Levasseur, CIRAIG

The instantaneous Radiative Forcing (RF_{inst}), in $W \cdot yr \cdot m^{-2}$ (Eq. 2-15), is formulated based on the aGWP (see Eq. 2-2 section 2.2.5), however with annual integration steps. The cumulative RF (RF_{cum}), in $W \cdot yr \cdot m^{-2}$ is the sum of the instantaneous RF at time (t) caused by the each emission of all previous years, thus representing the derivative of RF_{inst} (Eq. 2-16).

$$RF_{inst}(t) = aGWP_i(t)_{inst} = \int_{t-1}^t a_i[C_i(t)]dt \quad \text{Eq. 2-15}$$

$$RF_{cum}(t) = \sum_{i=0}^t RF_{inst}(t) \quad \text{Eq. 2-16}$$

Levasseur et al. (2010) suggested the development of relative values to make the results comparable with static CO₂-equivalent values (e.g. with the static IPCC GWP results) by means of the relative RF (RF_{rel}) metric. Therefore, RF_{cum} values of one pulse emission are divided by the RF_{cum} of one pulse emission of the CO₂ reference gas (Eq. 2-17). The RF_{cum} of CO₂ is computed by means of the IRF (see Eq. 2-5). The relative assessment still depends on the choice of a TH over which the RF is integrated. Yet, the selection of a TH can be flexible, by setting a “fixed future reference time” (Levasseur et al., 2016).

$$RF_{rel}(TH) = \frac{RF_{cum}(TH)}{\int_0^{TH} a_{CO_2}[C_{CO_2}(t)]dt} \quad \text{Eq. 2-17}$$

Different LCA scholars have found that the results with the dynamic LCA approach provide relevant case specific temporal information for decision making, among others, on: “the intensity, extent and frequency of the impacts” (Lebailly et al., 2014), the sensitivity of the results to various THs choices (Levasseur et al., 2012b), as well as the optimisation and mitigation options from scenario-bound simulations (Shimako et al., 2017).

The dynamic LCA method builds on a scientific foundation for temporal considerations relevant to other impact categories, as recently also applied to aquatic ecotoxicity of metals (Lebailly et al., 2014).

Another toxicity-related initiative is being carried out by the USEtox team (Rosenbaum et al. 2008), which presented at the 25th SETAC conference (Fantke et al., 2015) a dynamic version of USEtox, allowing for the user to determine a specific time horizon, instead of the steady-state perspectives used in the USEtox model for human toxicity and freshwater aquatic ecotoxicity.

Moreover, Shimako et al., (2017) developed a dynamic fate model and combined it with USEtox, to perform dynamic toxicity modelling and integrate it into the DyPLCA model (Tiruta-Barna et al., 2016), implemented as a proof-of-concept (see Box 2-6).

Box 2-6. Available tools for dynamic LCA

A few tools have been developed for the computation of dynamic LCA, some of which are listed below:

- **DynCO₂** is accessible as an Excel tool at <http://www.ciraig.org/en/tools.php> and implemented with

the support of the documentation manual in Levasseur et al. (2010b). The tool has been tested in several case studies for which dynamic inventories were required to be built before the application of the tool.

- **DyPLCA** is implemented and accessible as an online tool at <http://dypca.univ-lehavre.fr/> and <http://dypca.pigne.org/>, yet it is not fully documented. The formal description of the tool and its underlying specifications were introduced as a proof-of-concept in Tiruta-Barna et al. (2016), and will be shortly extended in the upcoming publication Pigné et al. (submitted) “A tool to compute fully time-differentiated life cycle environmental impacts of production-consumption systems” (Negishi et al., 2019, 2018).
- **Temporalis** is an open source software package for the development of dynamic LCI (Cardellini et al., 2018) based on the Brightway2 LCA framework (Mutel, 2017), using Python language. The tool is accessible at <https://temporalis.readthedocs.io/en/latest/> and it is well documented with technical guidance, however it is not readily operational.

To summarise, the LCIA part of dynamic LCA is somewhat covered by the Levasseur et al. (2010) model for climate change, and by other ongoing developments for other impact categories such as toxicity.

Nonetheless, the LCI component is less developed, in the sense that no consensus or widely used approach exists yet. Several approaches for carbon accounting (including biogenic and soil carbon) have been proposed, as discussed in the next section.

2.6 Carbon modelling for life cycle inventories

The Product Environmental Footprint Category Rules, referred to as the PEFCR Guidance (EC, 2018b), include three sub-categories for carbon in LCA linked with climate change:

- Climate change – fossil: GHG emissions originating from fossil fuels by means of their transformation or degradation (e.g. combustion, digestion, landfilling, etc.).
- Climate change – biogenic: carbon sequestration (CO₂ fixation from the atmosphere through photosynthesis during biomass growth) and carbon release emissions due to transformation or degradation (e.g. combustion, digestion, composting, landfilling). It represents the embedded carbon within bioproducts or biofuels.
- Climate change – land use and land transformation: carbon sequestration and release originating from carbon stock changes caused by land-use and land use change, including deforestation, road construction or other soil activities.

Fossil-sourced emissions have been computed in the past by means of the IPCC GWP (section 2.2.5), without the consideration of the time dimension, because it is argued that their turnover time into the geological pool is considerably slow (see section 1.1), and thus upstream carbon modelling approaches are static.

Yet, in the last decade the temporal differentiation of the release flows has been questioned, eventually delaying emissions (e.g. temporary storage in products and emission delay, see previous section 2.5.3). Further challenges in carbon modelling have been recognised in the context of biogenic carbon (C_{bio}), including carbon from soils and its associated land use/land occupation.

As highlighted in sections 1.2 and 2.4, the temporally differentiated modelling approaches for C_{bio} and C in the soils need further refinement in LCA, regarding linking with climate change impacts. Therefore, this section explores carbon modelling approaches used in science, as well as current applications in LCA.

2.6.1 Modelling biogenic carbon from biomass

Biogenic carbon (C_{bio}) represents the C in the biosphere and its exchange with the atmospheric pool (see section 1.1). CO_2 is fixed and sequestered into the living biomass (above- and belowground) by photosynthesis, and (re)emitted to the atmosphere at some point in time due to natural processes (e.g. respiration, degradation) or human activities (e.g. combustion). So far, there is no consensus in place on how to treat and value dynamic C_{bio} in LCA and how to model dynamic C_{bio} flows. Modelling approaches from static to dynamic are presented in this section.

Static biogenic carbon inventories and associated challenges

Biogenic carbon has increasingly gained importance in the context of climate mitigation and low-carbon economy, crediting the displacement of an energetically equivalent fossil-sourced C . Two main static accounting approaches for biogenic carbon exist, namely: exclusion from the inventories (carbon neutral) or taking into account changes in carbon stock. The former is the most commonly applied approach for bioenergy systems, and the latter relates mainly to national GHG inventories, although its application has been adopted to product level (Pawelzik et al., 2013):

- **Carbon neutrality** assumes a **net zero CO_2 emission** in the GHG inventories of bioenergy: The hypothesis relies on the assumption that the previously emitted carbon emission to the atmosphere is re-sequestered/fixed (instantly after emission) into the biomass (not necessarily related with the same product system boundary), balancing out fixation and release emissions. It thus neglects potential temporal climate change impacts from C_{bio} .
- **Carbon stocks** implicitly related with **land use change** (FAO, 2004) in the national GHG inventory reports (IPCC, 2006a), accounting for upstream carbon stocks in the LULUCF sector by means of the IPCC carbon stock change method (IPCC, 2006b). Carbon stocks, changes in stocks and resulting CO_2 emissions per unit of area (e.g. forestry, agriculture) are reported at the national level, but not at the product level (bioenergy), to avoid double counting (Zanchi et al., 2010). Consequently, CO_2 emissions from biofuels are excluded from the EU Emission Trading Scheme (Zetterberg and Chen, 2015). However, more recently EU

Member States can compensate LULUCF emissions within the same sectoral activity, as shortly introduced in section 2.2.3.

At the product level, some carbon stock accounting approaches and factors have been developed to estimate the C imbalance associated with bioenergy systems and their expansion due to displacement activities, most of which relating with **carbon debt from LUC** or forgone sequestration as well as the benefits from displacing energetically equivalent fossil C (see Box 2-7).

Box 2-7. Biogenic carbon stock approaches of bioenergy and fossil carbon displacement

Some terms or definitions relate to C imbalance of terrestrial C stocks due to bioenergy systems compared with fossil C, are introduced as follows:

- **Ecosystem carbon payback time (ECPT)** is a concept developed to estimate the time in years required to compensate for ecosystem carbon loss due with direct land use change, including forgone sequestration (see Box 2-11) attributable to crop-based bioenergy system expansion (e.g. conversion from forestry to energy crop production) (Gibbs et al., 2008). ECPT takes into account the net C changes in a terrestrial carbon stock (C imbalance) relative to the carbon benefits/savings obtained from fossil C displacement. Short payback time has been linked with the conversion of degraded land, while the ECPT from annual biofuel expansion into tropical forests has been estimated between 40-120 years, and production on deforested land or peat land, for instance, between 300-1500 years to compensate for the ecosystem loss (Gibbs et al., 2008). LUC due to food-crop-based biofuels may thus cause a permanent loss of within the terrestrial biological carbon stock (Pingoud et al., 2012). Nonetheless, the payback time may also decrease over time due to increases in carbon savings emerging from technology, efficiency and yield improvements (Yang and Suh, 2015).
- **Upfront carbon debt:** similar to the ECPT concept from LUC, yet related with forestry bioenergy and the accounting for the post-regrowth after harvest (Pingoud et al., 2012; Zanchi et al., 2010). It refers to modelling an existing forest carbon stock after the harvest activity, creating an initial carbon debt that is repaid/ restored by re-growth or by compensation with an equivalent reference case. The delay to repay for the consumed carbon creates an upfront debt that substantially reduces the potential of bioenergy systems to reduce the present GHG concentration in the atmosphere in the short to medium term (Lamers and Junginger, 2013; Mitchell et al., 2012).
- **Fossil carbon displacement factor (DF):** estimates the GHG balance and C mitigation efficiency of bioenergy as compared with fossil energy by means of the: a) avoided equivalent fossil C emissions relative to the biogenic C of the used biomass for bioenergy (direct energy substitution) or b) indirectly the avoided use of energy-intensive materials by biomass (indirect energy substitution) (Schlamadinger et al., 1997; Schlamadinger and Marland, 1996).
- **Carbon neutrality (CN) factor** (Zanchi et al., 2010), where CN factors represents GHG emissions from carbon stock changes of a bioenergy system in relation to a reference fossil fuel system at different time scales. Factor values indicate whether a bioenergy system emits more GHG emissions ($CN < 0$), saves emissions ($CN > 0$) or reduces or replaces fossil fuels ($CN > 1$).

Given the generalised carbon neutral assumption and static C_{bio} accounting of carbon stocks, three main challenges are recognised:

- CO₂ emissions have an effect on the atmospheric GHG concentration and thus on the RF, regardless of its origin, whether it is **biogenic- or fossil-sourced** (Cherubini et al., 2011a; Haberl et al., 2012).
- C_{bio} releases emitted as **non-CO₂ GHGs** and are not equivalent to the same unit of sequestered/reduced CO₂ in the atmosphere may have higher atmospheric perturbation capacities. Atmospheric CH₄, although difficult to quantify, mainly originates from biogenic sources such as wetlands, ruminant animals, rice cultivation, biomass burning, and to some extent from fossil fuel-related emissions (IPCC, 2013a). The ISO 14067 standard for carbon footprints (ISO, 2013) recognises zero net CO₂ emissions from complete oxidation, unless “when biomass carbon is converted into methane, non-methane volatile organic compounds (NMVOC) or other precursor gases”.
- Disregarding **temporal effects** from CO₂ (re-)sequestration into the biomass over a full rotation length (eventually over several decades) affects atmospheric GHG concentration and thus alters RF effects. Applying carbon neutrality to biomass with long rotation lengths, for instance, from forest wood, is criticised as an erroneous accounting approach (Haberl et al., 2012; Searchinger et al., 2009). CO₂ neutrality for forest wood-based bioenergy has been justified so far, as stated by Zetterberg and Chen (2015): “...the carbon that was once bound in the growing forest is released, thus closing the biogenic carbon cycle”. This approach, moreover, ignores the long-term storage of carbon in the wood (Leturcq, 2014).

The temporal dynamic of CO₂ sequestration in the biomass is modelled in ecology by means of growth analysis, shortly summarised below.

From static to dynamic biogenic carbon inventories

Estimating the temporal dynamic of C_{bio} sequestration in biomass is closely linked with plant **growth modelling** carried out in functional **ecology and growth analysis**, one of the aspects of ecological modelling. Growth is defined as the increase in size or weight (biomass) of a vegetation over all stages of growth (juvenile, adolescent, mature and senescent) (Pretzsch, 2009). Growth modelling approaches are used to predict the plant development and potential growth and yield classes.

The biomass growth curve of plants with related allometric variables such as height and diameter, mostly describe an initial rapid growth and the slowing or eventually falling thereafter in the senescent stage (Fekedulegn et al., 1999; Paine et al., 2012). Meaning that with increase in size, plants become inefficient (e.g. due to self-shading, tissue aging and turnover), with consequential reduction of Relative Growth Rate (RGR) over time (Rees et al., 2010).

RGR based on nonlinear growth models represents a flexible approach, accounting for varying growth rates (Pommerening and Muszta, 2016). Paine et al., (2012) claimed that traditional methods with linear (referring to constant absolute plant growth) and exponential (referring to loglinear with constant RGR) predictions are less adequate (see Box 2-8), since statistical computations fitting parameters using nonlinear regression (involving complex experiments) have matured and thus better capture the temporal dynamic/variations of growth (i.e. dependency of growth in age-and size).

Self-starting routines with initial parameter/starting values are required to fit non-linear regression models for the analytical computation of derivatives (Fekedulegn et al. 1999, Arne Pommerening, pers. comm. 2018). In different scientific fields it is common to use self-starting-functions with different parameters for the same model (datascience+, 2018). Archontoulis and Miguez (2015) provide guidance for fitting non-linear models primarily for agricultural research studies, however also applicable to forestry. Self-starting routines and solutions for the R language have been developed to enable model convergence (Paine et al., 2012).

Box 2-8. Biomass growth modelling

Classical plant growth analysis data draws back to the 1920s (Rees et al., 2010). Analytical tools via growth analysis have long been used for plant growth approximations (Hoffmann and Poorter, 2002). It allows fitting the growth curve from a small number of observations by means of absolute (AGR) and relative (RGR) growth rates, formulated in Eq. 2-18 and Eq. 2-19, respectively:

$$AGR = (M_t - M_{t-\Delta t})/\Delta t \quad \text{Eq. 2-18}$$

$$RGR = \ln(M_t/M_{t-\Delta t})/\Delta t \quad \text{Eq. 2-19}$$

where M represents the change in mass over a given time interval. Two points in time are considered in the computation of AGR, while RGR allows comparing individuals with different initial sizes (i.e. ratio of final to initial mass) (Hoffmann and Poorter, 2002; Rees et al., 2010). Thus, ARG represents the derivative of biomass as a function of time and RGR equals the AGR divided by the current biomass (i.e. growth per unit of mass). Yet, linear regression and (log)linear functions have been used are used to fit the curve (size vs time), while assuming exponential growth (Paine et al., 2012). Traditional approach have thus failed to consider the temporal dynamic (Rees et al., 2010).

Many methods have been proposed to describe growth models. There are two basic model classifications for growth, concerning asymptotic (limit in growth) and non-asymptotic (indefinite growth) growth curves (Paine et al., 2012). These classifications are briefly described below by highlighting some of the existing models.

(Log)Linear –non-asymptotic: The modelling approaches refer to two parameters: initial biomass and absolute (for linear) or relative (for exponential) biomass increase rate per unit of time:

- Linear models where the absolute growth rate is constant, meaning that the biomass change is proportional to time. They are less used in growth modelling due to their simplicity and because they fail at modelling the temporal dynamic, assuming **infinite plant growth**. To avoid negative initial values the biomass is set to zero (no-intercept model), yet affecting R^2 .
- Loglinear (exponential) models provide better fits than the linear models by using linear regression to fit the logarithm of biomass yields, commonly used for species with **unrestrained growth**, such as algae boom.
- Polynomial models predict smooth growth curves within the linear modelling framework. However the model faces challenges regarding the interpretation of the parameters, selection of the order and unrealistic predictions upwards and downwards. For this reasons it has been recommended to avoiding polynomial functions (Paine et al., 2012).

Non-linear –non-asymptotic: refer to power-law (allometry) models, which yield better R^2 , as they facilitate slowing the curve while biomass increases by decreasing the RGR with an exponent (β) formulation smaller than zero or larger than one ($\beta < 0$; $\beta > 1$) in contrast to linear models ($\beta = 0$ for linear and $\beta = 1$ for exponential models).

Non-linear –asymptotic: these models have a point of inflections and are sigmoid (Zhao-gang and Feng-ri, 2003), except for monomolecular models, shortly listed, as follows:

- Monomolecular (e.g. Mitscherlich): originates from physical chemical reactions by means of first order decay function with no point of inflection and always concave-down.
- Logistic models: the frequently applied three-parameter and four-parameter logistic models provide good fit with some limitations regarding the asymptote where the inflection point happens at one half of the maximum biomass, whereas models with five-parameter are more flexible. Examples are:
 - Chapman-Richards: this model is known for being very flexible and accurate on the slight expense of biological realism (Pommerening, 2017). It has been used for animal growth and increasingly applied in the forestry context to model potential cumulative tree growth (Fekedulegn et al., 1999; Pienaar and Turnbull, 1973; Pommerening and Muszta, 2016; Pretzsch, 2009; Zhao-gang and Feng-ri, 2003).
 - Weibull: Although originally intended to describe a probability distribution, the Weibull function has turned out to be a very reliable empirical model for tree growth (Pommerening and Muszta, 2016; Zeide, 1993).
 - Gompertz: differs from three-parameter logistic models concerning the inflection point approximating the asymptote 37% of the maximum biomass. The model is used in biology to refer to the exponential decay, however it was initially used to describe distribution of age in human populations (Pommerening and Muszta, 2016).

Power-law and asymptotic models are preferred options over (log)linear and polynomial models, overcoming the described limitations and providing more flexibility, as they can be generalised to avoid initial negative mass values and allow variation in the inflection point (Paine et al., 2012).

Data for informing modelling biomass growth rate (and related C_{bio} sequestration) is obtained via **destructive or non-destructive methods** (Tackenberg, 2007). The former refers to cultivation and sampling of individuals (fresh or oven-dried biomass) for constant measurements, while the latter uses time and cost effective techniques (e.g. visual obstruction sampling, vertical and horizontal image analysis, satellite remote sensing) with decreased number of samplings. Non-destructive methods were developed to follow the mean development of individual plants, mostly based on allometric relationships, particularly used for forest wood species.

Allometry, in the field of **relative growth**, analyses the empirical relation between size and shape (Mosimann, 1970; Pommerening and Muszta, 2016). Allometric equations allow estimating the correlation, for instance, between age and height and/or diameter or entire plant organs, thus the coefficients are interpreted as compound growth rates (Hunt, 1990, 1982). The international database GlobAllomeTree (<http://globalallometree.org/>) (Henry et al., 2013) with several contributing institutions such as the FAO and CIRAD, comprise more than 23.5k allometric equations for different tree species (involving above- and belowground plant compartments) in different ecological zones or geographical locations of the world.

Although growth rate models provide empirical evidence and thus adequate predictions of mean biomass/plant development, they are often limited to experimental data retained under standard or optimal condition, lacking variations on environmental effects (e.g. temperature, competitors, etc.) (Marcelis and Heuvelink, 2007; Tackenberg, 2007).

Ongoing research developments in RGR and non-linear regression have been oriented towards modelling, for instance, plant mortality and reproduction, climate change and biomass decline effects, particularly in forestry (Pommerening and Muszta, 2016).

C_{bio} sequestration can be estimated from biomass growth modelling for the entire plant or among plant compartments by means of **carbon partitioning** among the plant organs/compartments (i.e. carbon content per plant part). However, carbon partitioning among plant organs is challenging and represents a source of uncertainty (Henson, 2007; Marcelis and Heuvelink, 2007).

Beyond partitioning, by default, carbon content in biomass is assumed to represent around 50% of dry mass in all compartments (Aalde et al., 2006; FAO, 2005; Macías et al., 2017; Pretzsch, 2009).

Biogenic carbon modelling in LCA – temporal considerations

For bioenergy systems, most of the LCA bioenergy studies have used the **carbon neutral** hypothesis analogously to climate neutral, to express a zero net climate effect (Cherubini et al., 2011a; Guest and Strømman, 2014; Liu et al., 2019). The carbon neutral approach exclude C_{bio} fixation and release flows with EOL modelled as combustion or incineration, but includes fossil C emissions for biomass cultivation and biofuel production (Agostini et al., 2014; Johnson, 2009; Wiloso et al., 2016).

Several LCA scholars however have recognised the need for taking into account the **time lag** between the carbon sequestration and release, denoting temporary carbon storage, understood as the period over which C_{bio} remains in the technosphere/anthroposphere. During that period, radiative forcing is postponed (for biomass resources with long rotation lengths and long-lived products) or eventually avoided through permanent stocks (Christensen et al., 2009; Vogtländer et al., 2014).

The temporary carbon storage may account for a CO_2 benefit resulting from delaying emissions for a specific number of years from the C_{bio} embedded/retained in biomass-sourced products (P Pawelzik et al., 2013). This temporal consideration in the modelling of C_{bio} and its challenges has been thoroughly discussed in the past by the LCA community (Brandão and Levasseur, 2010).

Up to now, LCA guidelines and LCA software allow considering this dynamic by means of the **temporary carbon storage and delayed emissions** as a correction factor in LCIA (e.g. applicable to long-lived bioproducts such as wood materials), described in section 2.5.4. Other LCIA methods for valuing carbon storage have been suggested in the frame of tonne-year approaches (section 2.5.4).

Yet, none of the recommended approaches is dynamic, facing the main controversy for valuing the time lag, as the “temporary carbon storage is, by definition, reversible”, as stated by Levasseur et al. (2012a).

Efforts towards developing dynamic C_{bio} accounting approaches have recently emerged, specific to the construction and **building sector** (Box 2-9). These approaches have been developed in response to the insufficiency for decision-making of static estimates concerning temporary C_{bio} storage in products with long service life, often combined with the dynamic LCA method (section 2.5.6) (Beloin-Saint-Pierre et al., 2017; Peñaloza et al., 2016).

Box 2-9. Dynamic carbon accounting in LCA of buildings

Given the long lifecycle of buildings, static LCA is not well equipped to deal with time-dependent parameters associated with buildings (Negishi et al., 2018). Various efforts in the direction of defining a dynamic LCA framework for buildings have been carried out (Beloin-Saint-Pierre et al., 2017; Breton et al., 2018; Negishi et al., 2019; Pauliuk et al., 2013; Su et al., 2019; Wu et al., 2017).

The approach presented in Negishi et al. (2018, 2019), for instance, identifies the key dynamic characteristics

of a buildings' lifecycle (behaviour of dwellers, building products, energy infrastructure, energy mix, carbon uptake/releases from building materials, and EOL pathways). They used the DyPLCA tool (see Box 2-6). Su et al. (2019), on the other hand, classified the building's characteristics according to their embeddedness (embedded, such as materials, and operational, such as energy and water). Wu et al. (2017) also based their approach on the relative embeddedness of factors, over five building phases (materials, transport, construction, operation and maintenance and EOL), and compared the performance of "green" and conventional buildings taking into consideration the temporal shift in carbon intensity (i.e. green buildings have more embedded C than conventional ones in the construction phase, and less in the operational one). In their highly cited article, Pauliuk et al. (2013) combine material flow analysis with LCA to estimate the impacts of future building scenarios in Norway, by focusing on energy. Their approach features both temporal and spatial dynamics. Peñaloza et al. (2016) compared different types of buildings featuring forestry materials using dynamic LCA and C_{bio} accounting, using an approach and rationale very similar to the one presented in this dissertation (Fig. 2-19).

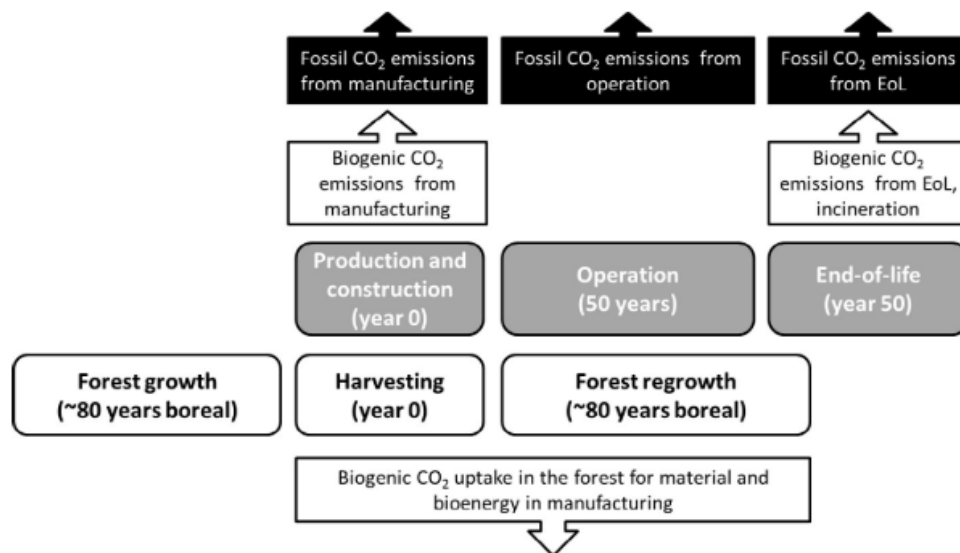

Fig. 2-19. Dynamic C_{bio} exchanges between production system and atmosphere. Source: Peñaloza et al. (2016)

Beloin-Saint-Pierre et al. (2017) combined the dynamic LCIA model by Levasseur et al. (2010) with the Enhanced Structural Path Analysis (ESPA) method by Beloin-Saint-Pierre et al. (2014) to describe flows by temporal distributions (i.e. temporally differentiating background LCI data), thus performing a fully dynamic LCA to a building-related case study, namely the comparison of alternative systems for the provision of domestic hot water.

The majority of discussed articles contrasted multiple scenarios, and most of the proposed approaches are specific to the building sector.

It seems that most efforts to model the temporal dynamic in LCI are associated with the **time lag from long-lived products**, particularly forest wood-based materials for buildings, as well as their time-sensitive energy demand, as identified in a search in Web of Science (TS=("life cycle assessment" OR "footprint") AND carbon AND building AND dynamic AND "climate change"); from year 2000 onwards). From the resulting 17 articles, eight relate to the time dynamic (see Box 2-9). Follow-up

searches in Web of Science, excluding building-oriented articles, yielded just a handful of articles dealing with dynamic C_{bio} accounting in contexts other than building-related (mainly bioenergy). The consideration of C_{bio} dynamic for all types of biomass-based products is less common than in buildings LCAs.

One of the few dynamic LCI approaches modelling C_{bio} dynamic as a function of time has been carried out by De Rosa et al. (2017). The authors have developed a user-friendly and flexible tool, based on a parametric model allowing for time-dependent modelling of C_{bio} sequestration and release flows from forest wood, including decay emissions. The dynamic inventory for C_{bio} fixation and storage in wood is applicable in both the bioenergy and biomaterial sectors.

The modelling of dynamic C_{bio} flows, independent from the sectoral implementation, faces one particular issue, namely the setting of the temporal boundary for the initial C_{bio} sequestration flow, i.e. defining the first year of CO_2 removal during biomass growth over a given rotation length, either before (historic) or after (future) the final harvest activity. This phenomenon is known as the “**chicken or egg causality dilemma**” (Levasseur et al., 2012c).

Case studies have applied the historic (Vogtländer et al. 2014; Zetterberg and Chen 2015; Demertzi et al. 2018), future (Cherubini et al., 2011b, 2011a; De Rosa et al., 2017; Levasseur et al., 2012b; Pingoud et al., 2016; Repo et al., 2015) and occasionally both (Fouquet et al., 2015; Levasseur et al., 2012c; Peñaloza et al., 2018) time perspectives, not necessarily within the LCA framework. Other works have discussed the problem (Matthews et al. 2014; Cornillier and Benoist 2015; Thrän et al. 2015), however, no guideline exists to date on how to justify the use of one modelling approach over the other.

To overcome these challenges for all types of biomass-based products, more research is needed on how to bridge the gap between carbon neutrality and the challenges associated with the temporal considerations of carbon sequestration and storage flows. The need for taking into account the temporal dynamic of negative and positive C_{bio} emissions and their time-sensitive climate change effects require establishing a better understanding of dynamic modelling approach.

An additional source of biogenic carbon is associated with the soil activities (referring to soil organic carbon), likewise C_{bio} increasingly gaining attention in the climate mitigation context, for instance, in the frame of the “4 per mille” initiative (section 2.2.3). Details on modelling approaches and its applications in LCA are further outlined in the next section.

2.6.2 Modelling soil organic carbon in the context of land use/land use change

Soil is considered as a **non-renewable** (finite) natural resource, as its time to regenerate from disturbances is slow, which is subject to competition between different land uses for cropping,

grazing, forestry, and urbanisation. More than one third of the world's soils are degraded through erosion, canalisation, compaction, pollution and nutrient depletion (FAO, 2019).

Soil is based on **living and dead biomass**, including particulate organics, humus and charcoal, soil microbes and fine plant roots (living) (Stockmann et al., 2013). The heterogeneous function (multifunctionality) of soils provide the physical, biological, chemical, and hydrologic basis for a wide range of **ecosystem services** (e.g. food, feed, fibre, fuel, medicine, habitat, nutrient cycling, water regulation, recreation).

Adhikari and Hartemink (2016) developed a conceptual overview on linking key soil properties (e.g. SOC, soil type, pH value, bulk density, soil biota, soil temperature, clay mineralogy) to ecosystem services through soil functions (e.g. carbon pool, source of raw material, biomass production, nutrient and water store, filtration and transformation). Their functions determine biomass yields in agricultural and forestry systems contributing to food, feed, fibre, and fuel production.

Soil organic matter (SOM) generally consists of about 50% to 58% of carbon (Duparque et al., 2007; Stockmann et al., 2013). The carbon content in the soil, the so called soil organic carbon (SOC), is an essential indicator to estimate the amount of soil organic matter (Lal, 2005; Meersmans et al., 2013). Carbon sequestration potentials under consideration of the plant-soil system have been linked to management practices (Lal, 2004; Minasny et al., 2017). Yet, it has been stated that the sequestration requires increases in added C to the soil over a defined period of time (Lal, 2008).

The SOC stored in the pedosphere is four times larger than that on the biosphere (see section 1.1); thus representing the largest terrestrial carbon pool (Luo et al., 2016). Large amounts of SOC are found in cool and humid regions, particularly in the northern circumpolar permafrost region (~1672 Pg C), amounting half of the global SOC stock within the belowground compartment (Tarnocai et al., 2009). The region is very vulnerable to increases in surface temperature, accelerating decomposition and thus increasing CO₂ and CH₄ releases.

There is a close relationship between **carbon and nitrogen cycle** in the soil, which has been studied since the late 1920s (Luo et al., 2016). As stated by Schweinle et al. (2015), the availability of SOM “is the end-result of previous processes of organic matter contribution, removal of organic matter, and mineralization”. Plant senescence and dead biomass mobilise carbon (sequestered previously through photosynthesis) and nitrogen to the soil, where a larger fraction of the C is lost through initial humification, while a smaller portion of the carbon and nitrogen are mineralised.

Bacteria and fungi are the decomposers of organic matter, contributing to breaking down recalcitrant organic materials (lignin, cellulose and hemicellulose) (De Boer et al., 2005). The complex “fungal-bacteria interaction” was found not to be always competitive, which is further studied by microbiologists.

A general consideration by the scientific community is that SOM decomposition and organic mineralisation are basically controlled by biological/biotic (living microorganisms and composition of plant residues) and environmental/abiotic (e.g. humidity, precipitation and temperature, soil properties, and N availability) factors (Schmidt et al., 2011; Shibu et al., 2006; Stockmann et al., 2013). Despite these research advances, the community still faces the challenge of understanding climate feedbacks and SOC flows in numerical models (Luo et al., 2016).

Soil organic matter modelling approaches

Modelling soil dynamic demands both understanding of soil science. Luo et al. (2016) summarised in Fig. 2-20 the main SOM transformation processes and controlling factors to predict SOC dynamics determined by environmental variables, litter quality, soil properties, microbial attributes and external disturbances. The complex dynamic interaction of SOC emerges exclusively from C inputs to the soil and its transformations into SOC, regulated by environmental and biological variables.

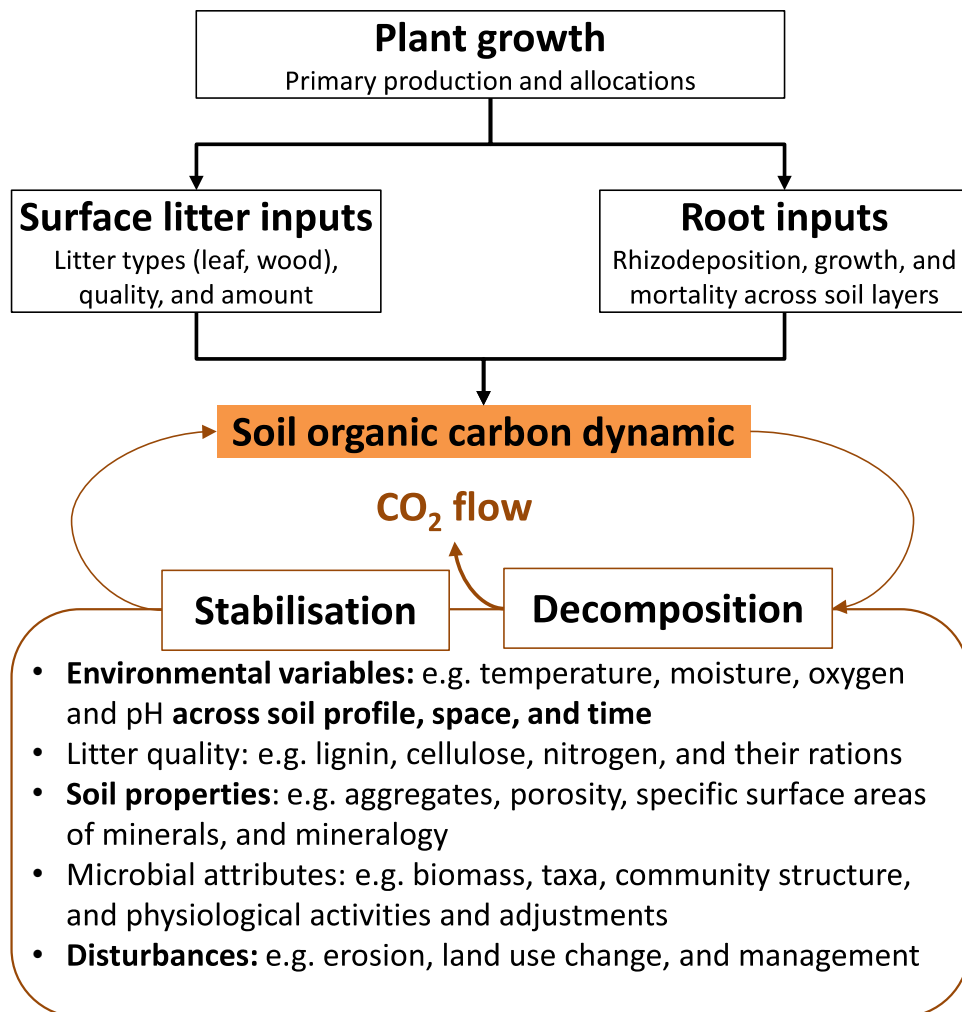

Fig. 2-20. Main variables and processes, for dynamic soil organic carbon modelling. Source: adapted from Luo et al. (2016)

Since the 1940s a large number of models were developed to predict SOM and its associated dynamic: from simple mono-compartment models based on first order decay function to model time-dependent decomposition rates (mostly fitting models to experimental data) in the 1960s, followed by multi-compartment simulations models in the 1980s (see Box 2-10) based on long-term experiments and complex process-based models in the late 1990s, mostly incorporating principles from analytical models (Shibu et al., 2006).

Box 2-10. The pioneering Hénin and Dupuis soil carbon model and multiple pool modelling

The pioneering model from Hénin and Dupuis (1945) described the dynamic decomposition of SOM of C inputs to the soil by means of the first-order decay function of the mass of C, formulated in Eq. 2-20 and solved analytically in Eq. 2-21:

$$\frac{dY(t)}{dt} = -kY(t) \quad \text{Eq. 2-20}$$

$$Y = Y_0 e^{-kt} \quad \text{Eq. 2-21}$$

where Y is the SOM content [$\text{g}\cdot\text{kg}^{-1}$] at time t ; Y_0 is the SOM content at time zero and k is the relative decomposition coefficient [yr^{-1}].

When modelling multiple pools, the C transfer within the pools, formulated in Eq. 2-22, where $Y(t)$ is the vector of pool sizes, B is a vector of partitioning coefficients among plant pools, A is a square matrix of transfer coefficients, $\epsilon(t)$ is a diagonal matrix of environmental scalars, k is diagonal matrix of exit rates (first order decomposition rate), Y_0 is a vector initial pool sizes (Luo et al., 2016, 2003):

$$\begin{cases} \frac{dY(t)}{dt} = Bu(t) - A\epsilon(t)kY(t) \\ Y(t=0) = Y_0 \end{cases} \quad \text{Eq. 2-22}$$

Most recognised SOC modelling approaches follow the structure of the IPCC guidelines (IPCC, 2006a) by means of a three level approach depending primarily on the study's purpose, data availability and spatial scale. Modelling approaches have been described in three levels: empirical, process-oriented and ecosystem models (further detailed in Appendix B: SOM models) (FAO, 2018b; Shibu et al., 2006; Stockmann et al., 2013):

- **Level 1: Empirical models (analytical models).** Applied to calculate the SOC stock changes based on the difference between a reference carbon stock and the carbon loss due to an intervention (e.g. land use change). The IPCC default period after SOC stock change intervention is 20 years, assuming that a new equilibrium is achieved within that period, yet the steady-state may require several decade. This approach is a linear representation of SOC stock changes and the data is mostly restricted to specific geographical regions (North America and EU), disregarding temporal and spatial dynamics from site-specific or local conditions (e.g. temperature and variability). The static approach does not allow assessing site-dependent effects of management practices on the SOC dynamic.

- **Level 2: Process-oriented models (conceptual models).** Used to predict SOC dynamic and stability based on multiple conceptual C pools/compartments to identify SOC changes from the past to the future. The complexity of the model increases with increasing number of pools. Each pool returns the C to the atmosphere with different turnover times. The active/labile pools (plant litter, microbial biomass) have a time steps of days to a few years, while passive/stable pool has time steps over decades, centuries up to millennia. The models run on site-specific or site-dependent variables involving climate conditions, soil type/properties, land use and management. They have been developed to assess the effects of different agricultural practices on yield crops, C/N dynamics, nutrient cycling. However, plant growth and yield production are not modelled, requiring data on C inputs to the soil.
- **Level 3: Ecosystem models (summary models).** Expand process-oriented models involving sub-models (plant growth, carbon and nutrient dynamic, soil water dynamics, and environmental/ecosystem interactions) calibrated to local and site-specific conditions (climate conditions, soil type/properties, land use and management), which influence the decomposition rates in the different carbon pools. These models require high level of data inputs, measurements or initial values whose application is very specific to an experimental site or approach (e.g. trade-off between SOC change and other environmental indicators).

Process-oriented and ecosystem models require more expertise and considerable amount of data inputs (i.e. biomass input and quality, initial carbon, soil type, climate conditions, management practices, etc.) to simulate, among others, the dynamics of SOC, nutrient cycling and the associated emissions to the air (CO₂, N₂O, CH₄).

According to Luo et al. (2016), not all variables and elements can be addressed in dynamic modelling, which require to explicitly state which processes and factors are incorporated or ignored.

Wiesmeier et al. (2019) recently published a review to identify key factors for SOC stock at different spatial scales, which can serve as a guidance to develop a system of indicators. For instance, climatic condition (temperature and precipitation), is generally recognised as a key influencing factor SOC at regional to global scales. Yet, the climatic factor becomes less important with increasing soil depth. Soil texture (for stabilisation) and C-input to the soil depend on key controlling factors related with **land use/management/vegetation characteristics**.

Spatial and temporal variability of soil organic matter

According to Cowell and Clift (2000), assessing **soil quantity** (e.g. loss from degradation and erosion) and **soil quality** (e.g. living organisms, non-living organic matter, trace substances, soil texture and structure) in agricultural systems require the incorporation of the temporal and spatial dimension

concerning the beginning and the end of a sequence of agricultural activities. The authors recommend analysing the whole system (e.g. involving subsoil compaction and nutrient leaching).

The temporal variability of the SOM decomposition is defined by the turnover time with rates within the different soil pools, ranging from 1-2 years in the **active/labile pool** (about 1/4 to 2/3 of the initial C is lost), to 10 to 100 years by a slow decomposition rates (about 90% of C loss), followed by the very slow decomposition rates in the **stable pool** with turnover times from 100 to more than 1000 years, where the OM is stabilised (protected from mineralisation) (Lützow et al., 2006). Charcoal, for instance has been estimated to have a mean residence time of 500 to 10 000 years. That is why the stable pool is often referred to as the **inert pool**.

Garrigues et al. (2012, 2013) highlighted the temporal and spatial variability as a major issue that lacks consideration of indicators to quantify the impacts on soil quality in LCA. Goglio et al. (2015b) recommends taking into account the timing of soil emissions in LCA.

Soil organic carbon modelling in life cycle assessment

Several LCA methods and models have been developed to assess the effects of agriculture, livestock or bioenergy production systems on soils. Up to now, there is no framework consensus in LCA on how to quantify and how to allocate soil-sourced emissions in the LCI and how to develop a consistent impact pathways in the LCIA (Goglio et al., 2015; Schweinle et al., 2015; Vidal Legaz et al., 2016).

Milà i Canals et al. (2007b) consider SOM as an indicator for soil quality and potential changes associated with land use. Other multi-indicator soil models for site-specific soil properties (e.g. SALCA-SQ (Oberholzer et al. 2012)), soil functions (LANCA (Beck et al. 2010; Bos et al. 2016)), soil ecological functions addressing ecosystem damage (Saad et al., 2011), as well as methods to quantify soil compaction (Garrigues et al., 2013), and soil carbon loss through soil erosion (Núñez et al., 2013, 2010), have been proposed within the framework of land occupation and transformation. Recently, the Product Environmental Footprint Guide (EC, 2018b) adopted and recommended the LANCA method.

Vidal Legaz et al. (2017) conducted a sound evaluation of eleven (out of 31 models) soil-related models under different criteria (i.e. scientific soundness, stakeholders' acceptance, reproducibility, and applicability) in an effort to improve available models to quantify soil quality, properties and functions in LCA. The authors have created a new impact pathway with pre-selected models, including biodiversity as end-point indicator (Fig. 2-21).

SOC changes have been proposed as a **standalone midpoint indicator** (expressed in $t\ C \cdot yr^{-1} \cdot ha^{-1}$) also linked with land occupation and transformation activities (Brandão and Milà i Canals, 2013), and

ultimately as an indicator for ecosystem services (Brandão et al., 2011; Milà i Canals and de Baan, 2015). Moreover, the PEF Guide (EC-JRC, 2013) listed SOC deficit as a default indicator for the land transformation impact.

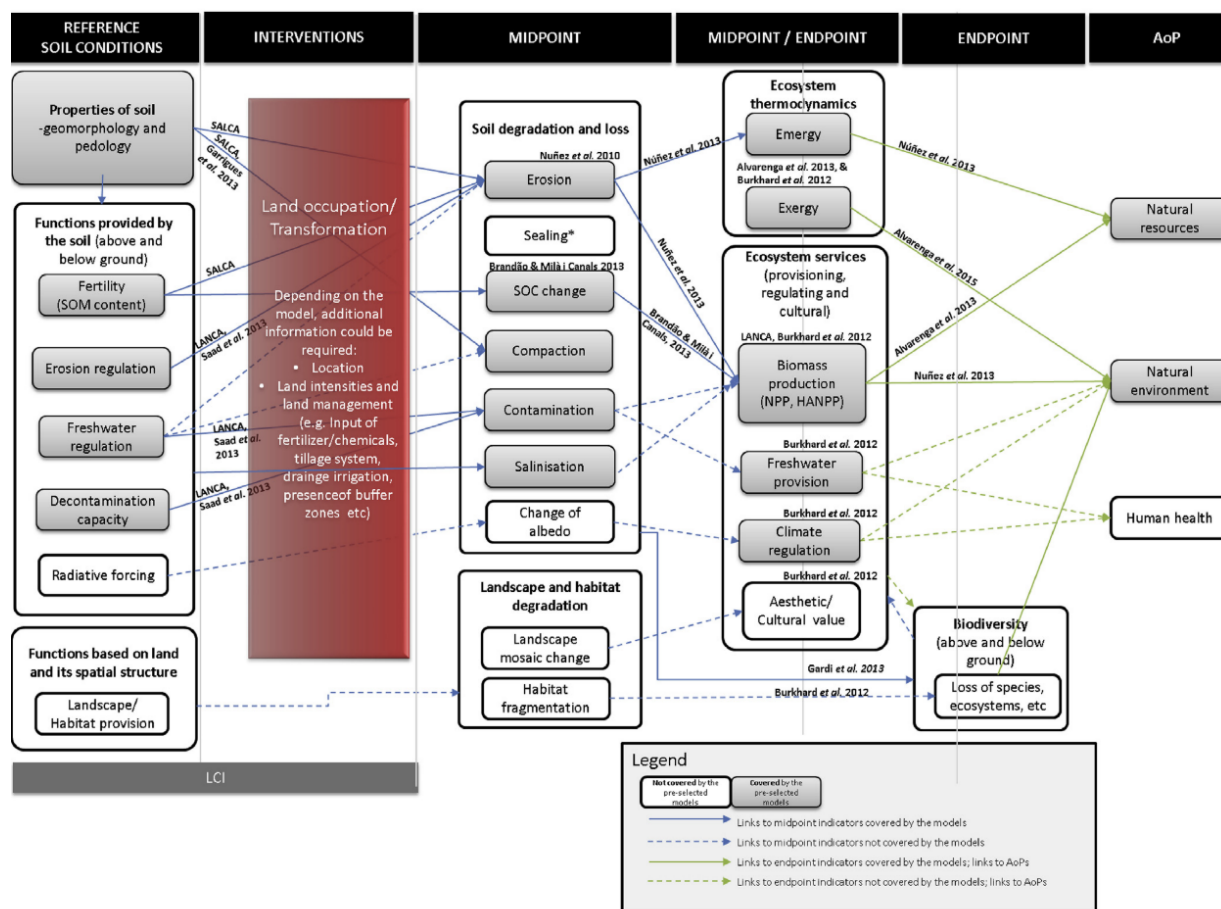

Fig. 2-21. Impact pathways for land use of pre-selected models in LCA. Source: (Vidal Legaz et al., 2016)

Other LCA scholars have also focused on the contribution of land use and soil C changes to the overall atmospheric GHG concentration, detailed in the next section.

2.6.3 Linking land use, soil organic carbon and climate change in life cycle assessment

Soil acts as a carbon sink/pool, but is also a source of GHG emissions (mainly CO₂, CH₄ and N₂O). According to Kirschbaum (2000) a small change of about 10% in the SOC could have a considerable effect on the atmospheric concentration of carbon equivalent to 30 years of anthropogenic emissions, and thus it is concerned with climate change.

Linking land, soil and climate change has been addressed since the initial days of LCA, but only in the last decade, operational approaches have been created to estimate some of these linkages (Fig. 2-16). Soil quality or properties are modelled in LCA from the effects of land occupation and transformation.

The approach, as well as most other published ones, is based on the seminal work on land use modelling in LCA by Milà i Canals et al. (2007).

Changes in SOC are often linked with land use (i.e. assessment effects of land use and management on soil). About 39% of the studies reviewed by Goglio et al. (2015), accounted for SOC change due to land transformation and 21% due to land transformation and land management change (LMC).

Land use modelling in LCA (expressed in unit of area per year) covers land occupation (land use) and land transformation (land use change), and also land relaxation (see Box 2-11 for the relevant terminology).

The land use framework proposed by Milà i Canals et al. (2007a) and recommended by the UNEP/SETAC Life Cycle Initiative highlight the three main impacts pathways associated with land use: biodiversity, biotic production and regulating functions of the natural environment. The Müller-Wenk and Brandão (2010) method tackles the regulation function of the natural environment pathway by assessing the impacts from CO₂ releases to the atmosphere from the global terrestrial biological carbon stocks (vegetation and soils from selected biomes) and the mean time the CO₂ remains in the air as a consequence from land use and land use change.

Box 2-11. Main terminology associated with land use and land use change

- **Land cover:** defined as the “observed (bio) physical cover on the Earth’s Surface”, synthesising several processes (natural and artificial) within the land activities (Di Gregorio, 2016).
- **Land use (occupation):** as defined by the IPCC (2013b, Annex III), land use refers to the total of arrangements, activities and inputs undertaken in a certain land cover type (a set of human actions). The term land use is also used in the sense of the social and economic purposes for which land is managed (e.g., grazing, timber extraction and conservation).
- **Land use change (transformation):** refers to a human-induced changes in the use or management, leading to *changes in in land cover* having different effects on local and global climate (surface albedo, evapotranspiration, GHG emissions) (IPCC 2013b, Annex III). It may also lead to changes in ecosystem quality (e.g. biodiversity loss) postponing land recovery (Goglio et al., 2015; Koellner et al., 2013b). The effects of change are differentiated in direct and indirect, defined in ISO Standard (ISO, 2013), as follows:
 - **Direct** land use change (dLUC): “change in human use or management of land within the product system”.
 - **Indirect** land use change (iLCU): “change in the use or management of land which is a consequence of direct land use change, but which occurs outside the product system being assessed”. It means that the consequence from land cover change due to another crop production system retains the demand for the displaced land somewhere else (Koponen and Soimakallio, 2015). It relates to competing land use and displacement effects, involving socio-economic and externalities (market mediated indirect effects), which have been assessed with

CLCA (Schmidt et al., 2015; Searchinger et al., 2008).

- **Land relaxation/regeneration:** abandoned land is an example of how a system regenerates back towards its natural state over time, yet the time for relaxation (i.e. the time to recover) mostly goes beyond the considered LCA THs (Koellner et al., 2013a). It thus refers to a time required for a system to recover. It would describe a baseline situation (Soimakallio et al., 2016) referring to a theoretical potential of a land use system to regenerated back to its quasi-initial natural steady state (Milà i Canals et al., 2007a).
- **Land use reference/baseline:** describes a reference system other than the studied product system, i.e. in absence of human intervention thus segregating technosphere from ecosphere/natural processes. A baseline thus allows identifying the emissions emerging from the production system. For ALCA the land use baseline is recognised in the previously described natural regeneration/relaxation (Milà i Canals et al. 2007a), and in term of physical flows both from natural and product systems should be contrasted to assess the impacts on ecosystem quality (e.g. biodiversity, carbon sequestration). A zero baseline situation, on the other hand, does account only for “absolute (observable) emissions” (Soimakallio et al., 2016), disregarding the effect of postponing natural regeneration, for instance, in bioenergy systems causing foregone carbon sequestration (i.e. a temporary reduction of C_{bio} and increase in emission), as compared with a no bioenergy situation (Koponen and Soimakallio, 2015). Specific to bioenergy systems, the baseline constitutes both reference comparisons equivalent fossil fuels systems and natural regeneration (no provision of a function).
- **Land management changes (LMC):** refers to be changes in agricultural cultivation practices of crops, excluding permanent changes in land cover (i.e. land use change). For instance, Goglio et al., (2015) reviewed the effects of SOC dynamic due to LCM associated with: crop selection, crop rotations with high-biomass crops, shifting crops (annual from or to perennials), change in bare fallow area, reduction/avoidance of biomass burning, tillage or not tillage, crop residue management, nutrient and water management, use of organic fertilisers, and management of organic soils and degraded land. Modelling LMC can be performed in different special scales using site-specific, site-dependent or site-generic data. The level of applicability and uncertainty differs among these scales, increasing and decreasing for site-generic modelling respectively.

Impacts from land use are complex and difficult to quantify, as they **vary over time and space** and are partially determined by other drivers/causes affecting water, soil and air quality, and producing carbon and biodiversity losses (e.g. forestland conversion to cropland or grassland, soil degradation/erosion) as well as ecosystem service degradation (Koellner and Scholz, 2007; Vidal Legaz et al., 2016).

On-site changes (direct due to conversion or changes in management practices) or off-site (indirect due to market-mediated and displacement effects) can have a wide range of short-to-long-term consequences on the global carbon and hydrological cycles, and thus on the Earth’s climate system.

A harmonised classification of land use and land cover types elementary flows at global scales is under current development by a working group in the frame of the UN Environment-SETAC Life Cycle Initiative (Koellner et al., 2013b). The guidelines described principles for in the land use impact pathways (based on Koellner et al. (2013a)), in which land use is modelled as an intervention (LCI level) and the impacts result from different land uses.

Both the UNEP-SETAC principles and the widely used ReCiPe method (Huijbregts et al., 2016b) links direct LUC to effects on biodiversity, via loss of habitat and soil disturbance, but excludes indirect LUC effects on biodiversity via land use-induced climate change (Goedkoop et al., 2013; Huijbregts et al., 2016).

Indirect land use change remains a controversial concept (Muñoz et al., 2015; Zilberman and Hochman, 2010). Nonetheless, various approaches have been proposed despite the lack of consensus on its reliability and interest in LCA (Gnansounou et al., 2008; Schmidt et al., 2015).

Methodological development enables the estimation, with increasing accuracy, of the impacts from land use, especially linking SOC and climate change (an often-neglected pathway, due to the complexity of its modelling) and biodiversity (for which multiple methods compete (Gabel et al., 2016)). The effects of land use on climate change have been modelled by means of complex simulation models, but an operational LCIA method is still missing (Cherubini et al., 2016).

Oertel et al. (2016) discussed soil-related processes and their influencing parameters that drive GHG emissions. The authors claimed that current global datasets lack spatial variability, as they are mostly restricted to some specific geographical areas. Besides the abiotic conditions (temperature and humidity), influencing factors or key drivers of GHG emissions relate to land use, land cover and vegetation. For instance, food systems contribute to about one third to GHG emissions, whereof 80 – 86% relates to agricultural land use.

Land transformation (i.e. land use change) may change land cover and the associated SOC stock. A meta-analysis of 74 studies indicated that largest SOC gains were achieved, for instance, through transformation from crop to pasture (+19%) or crop to forest (+53%), and vice versa highest SOC losses occurred from native forest to crop (-42%) and pasture to crop (-59%) (Gou and Gifford, 2002).

2.6.4 Current carbon modelling standards and guidelines

A variety of methods, technical standards and guidelines are available to quantify the environmental performance of organisations and products, many of which refer to carbon footprint, listed in Table 2.6. These carbon footprint approaches share a reliance on the reference IPCC GWP equivalency factors, including the 100 years perspective, as well as a generalised exclusion of offsetting mechanisms. Their treatment of biogenic carbon, carbon storage and delayed emissions is different, as

is their consideration of indirect LUC, as no widely accepted methodology is available. When biogenic carbon is recommended to be accounted for, it is mostly done separately.

Many comparative analyses have been published, highlighting the mutual alignment or lack thereof of the various approaches available (Bolwig and Gibbon, 2009; Cornillier et al., 2015; Gao et al., 2014; Pandey et al., 2011; Pelletier et al., 2013; Soode et al., 2013). The PAS 2050 standard (BSI, 2008) for products and the GHG Protocol (WRI/WBCSD, 2011) for organisations are among the most widely used ones, but choosing one standard often depends on the consideration of what the specific sector is doing, as well as on ongoing market and governmental initiatives. Current technical standards and guidelines, listed in Table 2.6, have different considerations and generally do not provide specifics on the temporal variability and dynamic carbon modelling approaches.

Table 2.6: Methodological aspects and recommendations in technical standards and guidelines related with carbon modelling

Criteria	IPCC (IPCC, 2006a)	GHG Protocol (WRI/WBCSD, 2011)	PAS 2050 (BSI, 2008)	ISO/TS 14067 (ISO, 2013)	ILCD handbook (EC-JRC, 2010)	PEFCR Guidance (EC, 2018b)	BPX 30-323-X (ADEME, 2011)
Documentation type	Guidelines National GHG inventories	International Product Life Cycle Accounting and Reporting Standard	UK's Product Carbon Footprint Standard	Technical Specification for the carbon footprint of products (CFP)	International Reference Life Cycle Data System, detailed technical guidance	European Environmental footprint Guide	French Environmental Footprint Guidance, for environmental product labelling
Scale	National	Company	Product	Product	Product	Product	Product
Fossil carbon	IPCC GWP	IPCC GWP	IPCC GWP	IPCC GWP	IPCC GWP	IPCC GWP	IPCC GWP
Biogenic carbon	Yes * (reported in AFOLU sector)	Yes*	Yes, except food and feed	Yes*	Yes*	Yes*	Yes*
Land use change/transformation	dLUC (20 years default)	dLUC* (20 years default)	dLUC* (20 years default)	dLUC* (IPCC)	dLUC* (20 years default)	dLUC (20 years default) follow PAS 2050	dLUC
Soil (organic) carbon uptake, stock or stock change	Yes, from LUC	Yes	Exclude	Yes*, if not calculated from LUC	Yes from LUC (20 years default); IPCC factors	Yes, but exclude uptake, storage	N/A
Temporary sequestration (i.e. atmospheric removal/uptake)	N/A	Yes* as a result of dLUC	Optional*	Optional* as a result of dLUC	Account for as "Resources from air"	Account for as "Resources from air" (ILCD handbook)	Optional (from replanted forest)
Carbon storage and emission delay (during use and EOL phase)	N/A	Exclude or reported separately	Yes, for short term (≤ 100 yr); for long-term; (>100 yr) report separately	Exclude, but shall reported separately	Yes, for short term (≤ 100 yr); for long-term (>100 yr) report separately	Yes, for long-term (> 100 yr)	N/A
Methods for carbon stock calculation	Stock difference	Carbon content in biomaterial	Carbon content in biomaterial	N/A	Correction elementary flow for ≤ 100 yr (negative)	Rules in the PEFCR	N/A
Offsets (credits from emission trading)	N/A	Include	Exclude	Exclude	N/A	Exclude	Exclude

* report separately. Acronyms: GHG: Greenhouse gas; dLUC: direct land-use change; CFP: Carbon footprint of products; AFOLU: Agriculture, Forestry and Other Land-Use; CHF: Characterisation factor; PEFCR: Product Environmental Footprint Category Rules; N/A: Not applicable
Source: own elaboration

2.7 Chapter conclusion

This literature review chapter provided theoretical foundation and background information on the state of the art of research developments and gaps relevant for this dissertation.

Two fundamental elements have been outlined in detail, namely the generalised lack of consideration of the temporal dynamic in LCA, and the exclusion of dynamic biogenic carbon flows associated with climate change. The latter is a direct consequence of the former: existing modelling approaches, based on a simplified aggregation of carbon flows with no temporal differentiation, are static, thus justifying carbon neutrality of biomass-derived carbon. Moreover, an essential temporal consideration has been identified by linking C_{bio} , SOC and land use.

The review on the temporal limitations in LCA (described in section 2.4), and methodological developments in LCIA (section 2.5) have partially been used as contributing elements to a Review Paper in preparation (the draft is included in Appendix A: Paper 4 – Review paper on the time consideration in LCA).

Table 2.7 summarises the general temporal limitations and proposed approaches in LCA, including the main findings of section 2.5 and 2.6. Relevant research elements in this work are highlighted and assigned to the following ranking: not relevant (-), relevant (+), very relevant (++), and indispensable (+++). It has been identified that less research has been conducted on the modelling of dynamic carbon flows than on other temporal aspects in LCA. Despite the variety of proposed methods linking C_{bio} , **SOC**, **land use**, land use change and climate change, no comprehensive dynamic framework for carbon modelling in LCA context is available. No single one among the proposed method and approaches takes into consideration all aspects of carbon modelling and dynamic assessment.

The next Chapter outlines a proposed framework for dynamic carbon modelling. It aims at contributing to the dynamic LCA methodology, particularly emphasising on how dynamic LCIs could be obtained, by the temporal consideration in the modelling of biogenic-sourced flows.

Table 2.7. Temporal limitation in LCA with special focus on climate change, perspectives and relevance

Issues	Concerned phases	Description	Examples of current developments	Relevance for thesis
Computation techniques of the temporal dynamic	G&S	The computation disregards temporal information (e.g. timing of emissions, time lags, variability) within the process matrix. The impacts are assumed to be linearly proportional to the aggregated emissions, and thus to the reference flow.	ESPA for temporally defined processes (Beloin-Saint-Pierre et al., 2014) DyPLCA tool (Tirutu-Barna et al. 2016) Temporalis tool (Cardellini et al., 2018)	-
	LCI			
Background datasets	LCIA	Challenges considered for temporal data variability in existing databases	Temporal differentiation of datasets (Pinsonnault et al., 2014)	-
	I			
Dynamic modelling	x	Temporal variability of substances due to complex environmental mechanisms depending on different parameters, such as, the lifetime of substances and the resilience of ecosystems	Time inherent sensitivity in the process tree (Collet et al., 2014) Modelling frequencies (Lenzen et al., 2006).	+++
Modelling system evolution	x	Evaluation of emerging systems, adoption to new technologies and changes over time contradicts implicit steady-state perspectives	Agent-based modelling (Davis et al., 2009; Knoeri et al., 2013; Miller et al., 2013; Noori and Tatari, 2016) Partial-equilibrium models (Levasseur et al., 2017; Menten et al., 2015; Vázquez-Rowe et al., 2013) Scenario-bound modelling (Nuñez et al., 2013; Pehnt, 2006)	++
Temporal boundaries, time preferences	x	Value-laden and subjective choice of TH Problematic of bridging vs sustainable solutions: what impacts have higher time relevancy	TH dominance criteria (Dyckhoff and Kasah, 2014) Theoretical framework for discounting (Yuan et al., 2015)	+
Temporal inconsistency of the static GWP	x	Inconsistency between study boundary and LCIA timeframes	Time-dependent CF and DynCO ₂ tool (Levasseur et al., 2010a) Time-corrected metric (Kendall, 2012; Kendall et al., 2009)	++
Biogenic carbon	x	Carbon neutrality hypothesis excludes impacts from biogenic biomass sources	GWP _{Bi} metric (Cherubini et al., 2011a) Tonne-year methods (Fearnside et al., 2000; Moura Costa and Wilson, 2000) Carbon sequestration (Vogtlander et al., 2014) Forest model for biogenic carbon balance (De Rosa et al., 2017)	+++

Source: own elaboration. Acronyms: G&S: Goal and scope definition; LCI: life cycle inventory; LCIA: life cycle impact assessment; I: Interpretation; TH: Time horizon; ESPA: Enhanced Structural Path Analysis; GWI: Global warming impacts; GWP: Global warming potential; iLUC: indirect land use change
Relevancy: not relevant (-), relevant (+), very relevant (++), indispensable (++++)

Chapter 3:
A framework for dynamic
carbon modelling

3 A framework for dynamic carbon modelling in LCA

3.1 Chapter context

The previous chapter provided a theoretical overview and description of the relationship of climate change assessment with biomass-derived products. It also highlighted the relevance of dynamic carbon modelling, thus contributing to establish the context of the thesis and the current gaps being addressed in this work.

Building on prior scholarship, this chapter proposes a framework, contributing to the methodological development of dynamic LCA in terms of dynamic carbon modelling and climate change: i.e. the development of dynamic carbon inventories (including C_{bio} and SOC) of different types of biomass-sourced process and product pathways (i.e. associated with biomass supply chains) under the consideration of the temporal carbon emission profiles throughout the LCA phases.

The main objective of this chapter is thus to propose a comprehensive framework integrating all aspects of carbon modelling alongside the LCA phases (described from section 3.3.1 to 3.3.4), generic enough to build a methodological basis for dynamic carbon inventories, underlying the following aspects:

- Defining terminologies throughout the LCA phases;
- Describing the dynamic character of biogenic carbon and the timing of emission flows;
- Determining the main time-dependent modelling elements (from upstream to downstream).

The purpose of the framework is to support the development of **complete carbon balances (fossil and biogenic-based)** of biomass-based systems, and to highlight key elements, which require dynamic modelling. A simplified cradle-to-grave example (section 3.4) delivers a better understanding of dynamic modelling and the temporal consideration, in contrast with the static classic LCA modelling approach. It is to mention that this approach does not stress on full LCA studies, as it centers solely on the dynamic elements of biogenic- and fossil-sourced carbon flows along the life cycle.

The dynamic elements are further elaborated and tested in the frame of case studies carried out in Chapters 4 and 5, to further support the recommendations made.

3.2 Framework proposal: dynamic carbon modelling for dynamic LCA

The proposed framework for dynamic carbon modelling incorporates the time dimension in the environmental assessment of biomass-based products, deriving from dedicated forestry and agricultural systems, and involving residual matter and biowaste.

Fig. 3-1 provides an overview of the proposed framework aligned with the classic LCA framework, encompassing the four LCA phases, but emphasising the LCI phase, with the purpose of modelling time dynamic C_{bio} flows throughout the life cycle of biomass-sourced products, including soil organic carbon (SOC), to fulfil climate change mitigation potentials. The priority is thus to set on the **climate change impact category** applying dynamic methods, for which dynamic characterisation factors already exist.

Moreover, the dynamic inventory modelling in the framework can be coupled with any **demand model**, informing on **time-dependent** scenarios (e.g. predictive, explorative or normative) based on socio-economic flows, including:

- Evolving markets, technological innovation and prospective pathways;
- Climate-energy policies analysis and multi-annual mitigation strategies;
- Temporal-spatial differentiation (site-dependent and site-specific parameters);
- Externalities and marginal data.

Chapter 3: A framework for dynamic carbon modelling

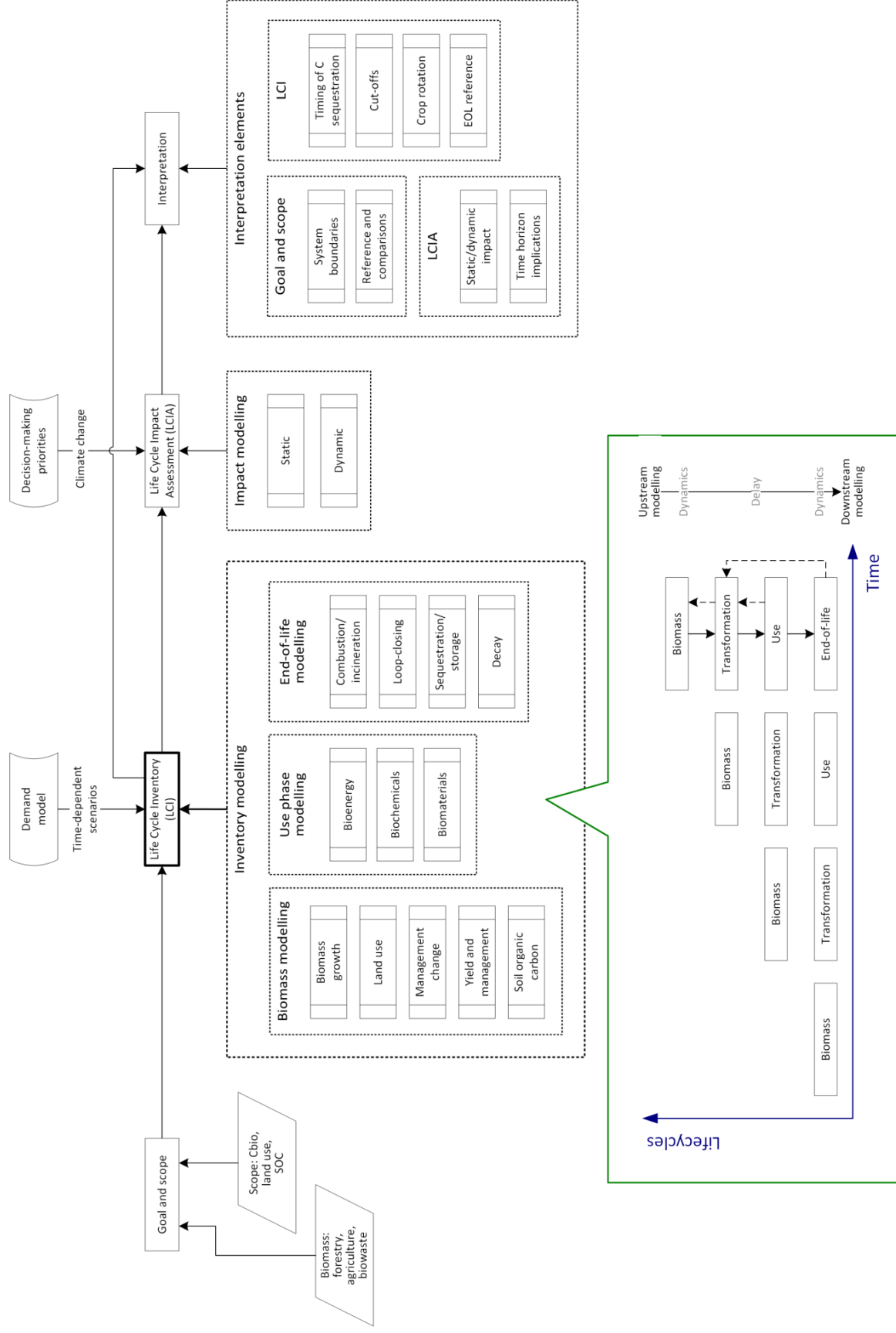

Fig. 3-1. Proposed framework for dynamic carbon modelling in life cycle assessment

3.3 Elements for dynamic modelling along the life cycle phases

3.3.1 Goal and scope phase: consideration of the time dimension

Defining biomass-based products and carbon dynamics

The **biotic products** addressed by the framework originate from **managed forests and agricultural systems** within the technosphere/anthroposphere. The technosphere includes cultivated biomass systems, featuring high levels of human intervention (Lindeijer et al., 2002), and linked with various economic activities (processes and services) throughout the biomass value and supply chains. These types of bioproducts play an increasing role in climate mitigation strategies and in the context of bio-economy and biorefinery in industrial systems.

The raw material/feedstock of bioproducts originates from **biomass** (vegetation) from the aboveground (stem, branches, leaves) and belowground (roots) plant compartments. It is characterised by its high carbon content (about 50% by default) and its natural renewability. Biomass can be regrown and it may eventually represent a carbon sink, in contrast with the abiotic fossil-derived counterpart, which is non-renewable and represents a carbon source (e.g. petroleum fuels, mineral fertilisers, synthetic materials).

The term **bioproduct** encompasses bioenergy (e.g. transport biofuels, electricity and heat) and biomaterials (e.g. wood lumber for construction housing, polymers, intermediate chemical compounds solvents, plastics, adhesives, personal-care products). It also includes **biowastes** with an economic value (wood chips, soil amendments, organic fertilisers, cooking oil, sewage sludge, etc.) not necessarily linked with downstream processes (waste treatment), as they represent co- or by-products emerging from processes at any life cycle stage.

Fig. 3-2 provides an overview of the biomass sources linking different processes pathways to the end use bioenergy and biomaterials. More details on the processes and pathways along the life cycle phases are provided in Appendix C: Biomass pathways.

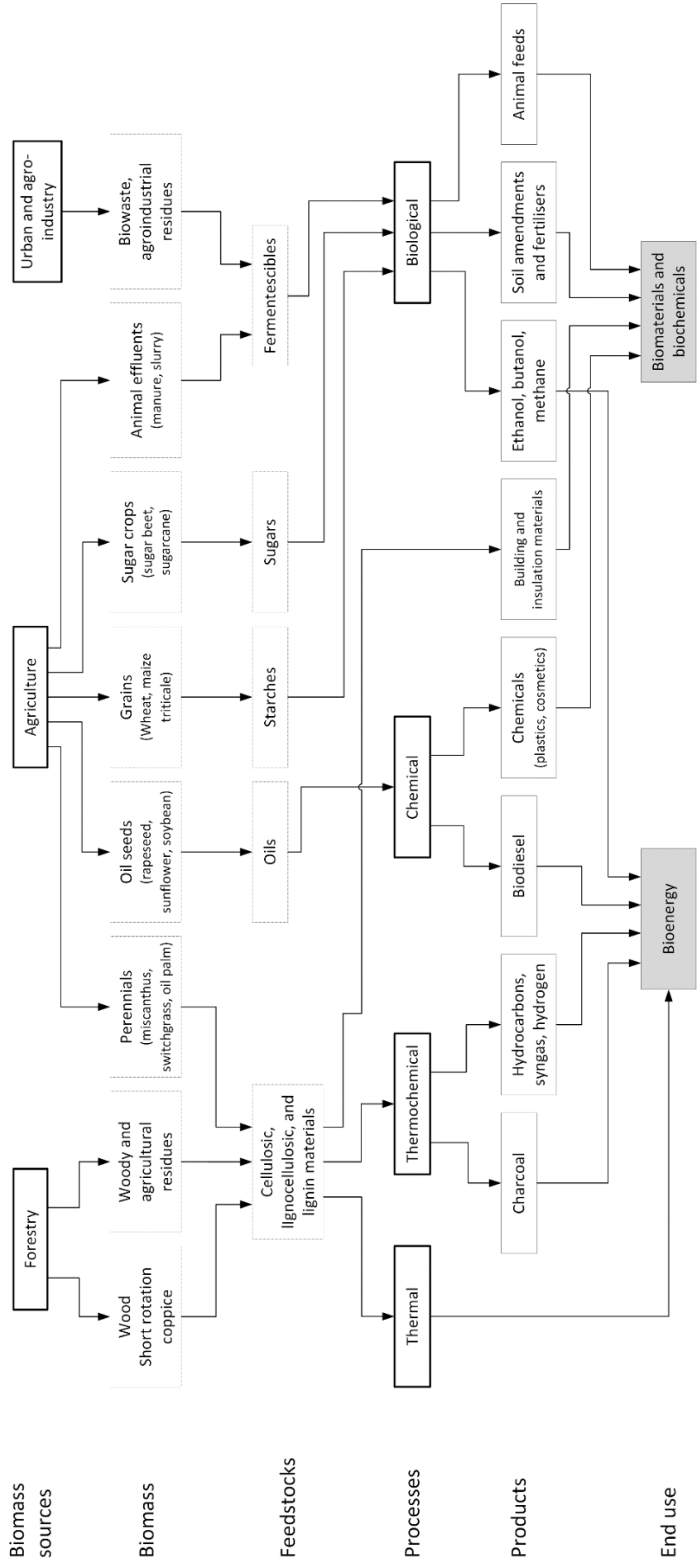

Fig. 3-2. Biomass-sourced process pathways to bioenergy or biomaterials and biochemicals

Biomass feedstock deriving from agriculture/aquaculture or managed commercial forestry includes two main categories:

- i. **Dedicated:** starch crops (e.g. wheat, corn), sugar crops (e.g. sugar beet), oil seeds (e.g. rapeseed, sunflower), lignocellulosic biomass (e.g. miscanthus, switchgrass, poplar, willow, forest wood), algae (here also summed up as annual and perennial crops, woody and aquatic biomass), and
- ii. **Residues or biowaste:** lignocellulosic residues (e.g. forest brushwood, other woody residues), herbaceous and agricultural residues, agro-industrial residues.

Residues/biowaste can be further categorised between primary (agricultural and forestry raw material) and secondary (manufacturing processes) and tertiary (consumer/household) feedstock (Odegard et al., 2012). Biomass feedstock not accounting as primary, are, for instance: fats and oils (animal fat, cooking oil), other organic waste and residues (e.g. various manure, urban waste), industrial biomass and biomass mixtures (e.g. paper-pulp sludge, sewage sludge, refuse-derived fuel, paper wastes, saw dust) (Cherubini et al., 2009b; Vassilev et al., 2010).

Biomass features vary in compositions (e.g. concentrations of protein, fatty acids, carbohydrates, fibres as well as the moisture content) (Vassilev et al., 2010), thus undergoing different conversion methods and technologies: physical/mechanical, thermal, thermo-chemical, chemical, bio-thermo-chemical and electro-chemical processes. More detailed classification of biomass feedstock and process pathways was discussed in Cherubini et al. (2009b).

This framework deals primarily with the dynamic of carbon naturally embedded in **primary** biomass sources. More precisely, with the time-dependent carbon exchange flows originating from biotic resources hereafter referred to as **biogenic carbon (C_{bio})**. The carbon considered as input to the soil, hereafter referred to as **soil organic carbon (SOC)** should also be modelled, because it likewise originates from biotic resources. In the global carbon cycle, C_{bio} and SOC exchange flows are associated with the biosphere and pedosphere respectively (i.e. terrestrial biological carbon cycle).

Dynamic C_{bio} refers to the **living biomass** in the aboveground and belowground plant compartments, while SOC accounts for the **dead biomass**, involving residual plant fractions in the aboveground (e.g. brushwood, litter), dead roots in the belowground and biowaste used to produce organic fertilisers and soil amendments (e.g. animal effluents, compost, vinasse, biological sludge, press cakes, etc.), which in turn are exogenous inputs to the soil.

Purpose of modelling dynamic carbon flows

There is an urgent need for climate change mitigation, and dynamic carbon profiles, which may provide a more accurate picture of “real” mitigation potentials, for instance towards climate targets. The consideration of the temporal dimension requires the development of **temporal emission profiles**,

dealing with temporally differentiated **elementary and technical flows**. Biomass as a resource derives from dynamic systems, and is thus time-dependent (e.g. growth dynamic of plants, product-related life cycle carbon flows); while other systems may be modelled with static or steady-state approximations (e.g. industrial systems).

The temporal consideration through dynamic modelling has three main purposes:

- i. Model the **C_{bio} and SOC dynamics**, not considered under the carbon neutral hypothesis, and account for the time the carbon accumulates and remains in the technosphere, thus contributing to either climate change or climate change mitigation.
- ii. Account for the **temporal variation** of all carbon flows of a specific biomass type and derivative bioproducts from and to the atmospheric pool.
- iii. Develop **complete dynamic carbon inventories**, including both biogenic and fossil sourced emissions.

Defining the modelling time step

The time step for dynamic carbon flows is set to be **annual**. As described in section 2.4, the temporal frequency of emissions and substances is an inherent temporal characteristic of the impact category. The assessment of climate change effects assumes well-mixed forcing compounds having atmospheric lifetimes longer than one year and thus distributed globally. The annual time step is thus recommended for the computation of technical and elementary flows.

Setting the temporal study boundaries

For time-dynamic LCA, it is essential to define the **temporal boundaries** beyond the requirements from the LCA ISO 14040/14044 standard (ISO, 2006a, 2006b), referring to the TH of the impact characterisation (here IPCC GWP over 20 or 100 years for the climate change impact category). In the classic (static) LCA and carbon footprint approaches, there is no temporal discrimination of the emission flows, given the aggregation of all inventoried GHG elementary flows, which are then characterised in the same way, due to the application of a fixed TH.

In contrast, the dynamic framework proposes to specify a **study TH** by: a) describing the temporal emission profiles of the modelled system and thus defining a **LCI TH**, and b) determining a future reference year of the impact assessment by means of the flexible/variable **LCIA TH**. By setting the LCIA TH, for instance over 100 years (most commonly use TH) or any end-year along the impact assessment timeline (possible with the dynamic approach), it will be transparent whether **temporal cut-offs** are carried out in the assessment of the time-dependent GHG inventories.

Fig. 3-3 illustrates the two available options with dynamic LCA, primarily determined by setting an end-year to the impact assessment timeline and thus defining an LCIA TH, which in turn determines

whether all inventoried carbon emissions described within the LCI TH (temporal emission profiles) are covered by the characterisation. Temporal cut-offs are given in the opposite case of LCIA TH lower than LCI TH and no temporal cut-offs are given in the case of LCIA TH larger or equal than LCI TH (all inventoried emissions are considered). Finally, the setting of an end-year for the impact assessment (a future reference year) will ultimately define whether all inventoried dynamic carbon emissions (given by the LCI TH) are covered or not.

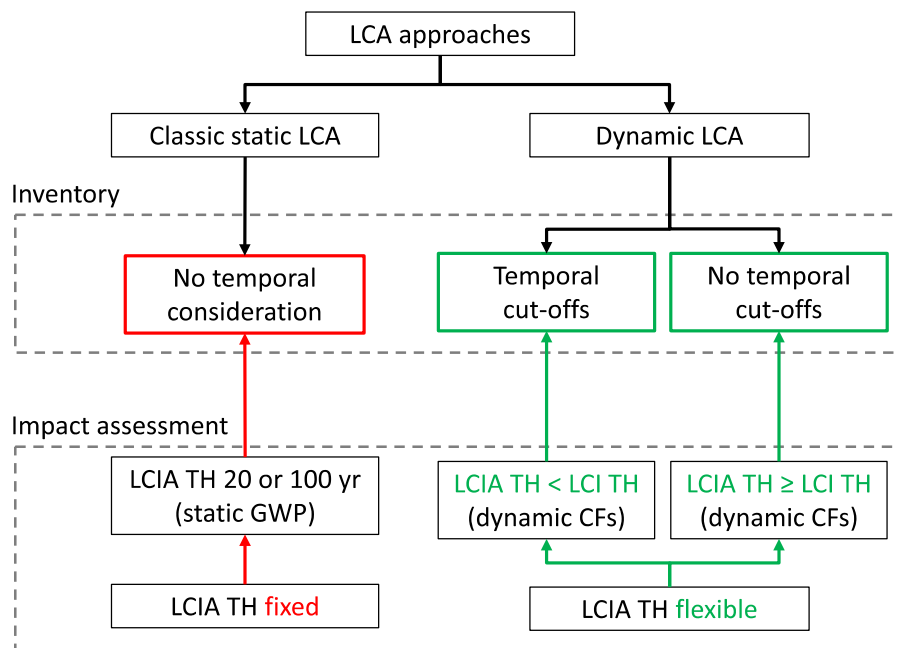

Fig. 3-3. Main temporal implications of classical static and dynamic LCA approaches at the inventory and impact assessment level

The setting of a LCIA TH is mainly carried out to enable the comparison with static approaches.

3.3.2 Dynamic LCI: timing of the emission flows

Dynamic models describe the carbon flows along the product's life cycle through time, specifying when in time the emissions take place. It allows developing temporal emission profiles of bioproducts, accounting for the **temporal variation** of the carbon exchanges from and to the atmosphere. The temporal emission profiles build the bases for dynamic inventories in the context of dynamic LCA.

The dynamic inventory associated with biomass and the respective derived bioproducts, represents a **full lifetime carbon accounting**.

Fig. 3-4 illustrates the C_{bio} and SOC exchanges to be considered between the atmosphere and the technosphere, along the life cycle phases of a product. The removal of carbon from the atmospheric pool and fixation in biomass through photosynthesis during growth, describes the **carbon fixation and sequestration flow** (green arrow). The same unit of sequestered carbon may be emitted back to the atmospheric pool by means of one or several **carbon release flows** (orange arrows), occurring at the

EOL phase or from any process emissions along the product life cycle phases before the EOL. The carbon embedded in the intermediate or final product may represent a **carbon stock** (black arrows), if the carbon release is delayed through time and thus postponing radiative forcing. Additional carbon flows may be considered (dashed black arrow), for instance, to capture carbon inputs to the soil (i.e. SOC) at the upstream, as well as eventual loop-cycling processes within the life cycles (e.g. recycling, reuse).

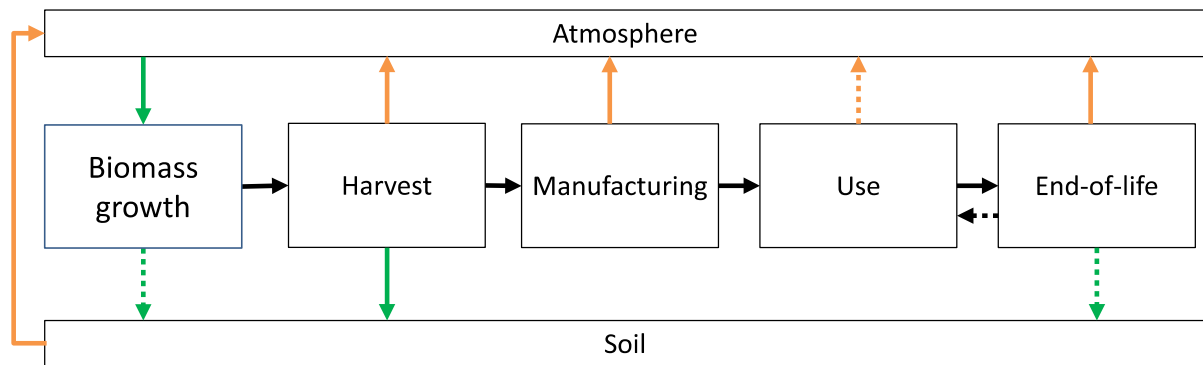

Note: Arrows (orange coloured) from the atmosphere to the biomass or soil represent fixation and sequestration flows, arrows (green coloured) leaving to the atmosphere represent release flows, and arrows (black coloured) between the life cycles represent the exchange flows between processes or eventually carbon stock due to a delay

Fig. 3-4: Carbon exchange flows between the atmosphere, biomass compartments and soil along the bioproducts life cycle phases

Computation of negative and positive carbon flows

Carbon emissions released to the atmosphere represent positive, while carbon removals from the atmosphere represent negative radiative forcing effects. Therefore, the exchanging carbon flows are inventoried as: a) **negative flows** for all carbon sequestration, representing a cooling effect due to removal of carbon from the atmospheric pool (contributing negative radiative forcing), and b) **positive flows** for all carbon releases, representing the warming effect due to carbon re-emission to the atmosphere. The computation of both negative and positive flows represents the **net dynamic biogenic carbon balance** of the studied systems (i.e. annually disaggregated inventories).

A **complete dynamic carbon balance** (“C-complete”, as opposed to “C-neutral”, which disregards biogenic carbon) does include carbon exchange flows from abiotic resources, i.e. the fossil carbon emissions resulting from the production and consumption processes of bioproducts. In contrast to biotic resources, fossil-sourced releases are inventoried as positive emissions only, as their turnover rates into the geological pool are considerably slow.

Key elements in the dynamic life cycles

Fig. 3-5 shows the classic LCA approach involving the main phases of the life cycle, here biomass extraction, transformation use and end-of-life disposal. The temporal information refers to each phase, however, the dynamic is particularly linked to the upstream and downstream modelling, eventually involving an emission delay may during transformation and use phases. Temporal carbon profiles are thus exclusively associated with three key features along the life cycle phases:

- **Rotation lengths and growth dynamic** (upstream): referring to carbon fixation and sequestration dynamic during plant biomass growth.
- **Service life** (use phase): referring to potential carbon stocks delaying carbon releases.
- **Release pathways** (downstream or during any product life cycle phase): referring to carbon releases contributing to atmospheric GHG emissions. The releases are associated with two phenomena: product end-of-life (EOL) emissions and/or process emissions happening at any time before the product EOL phase.

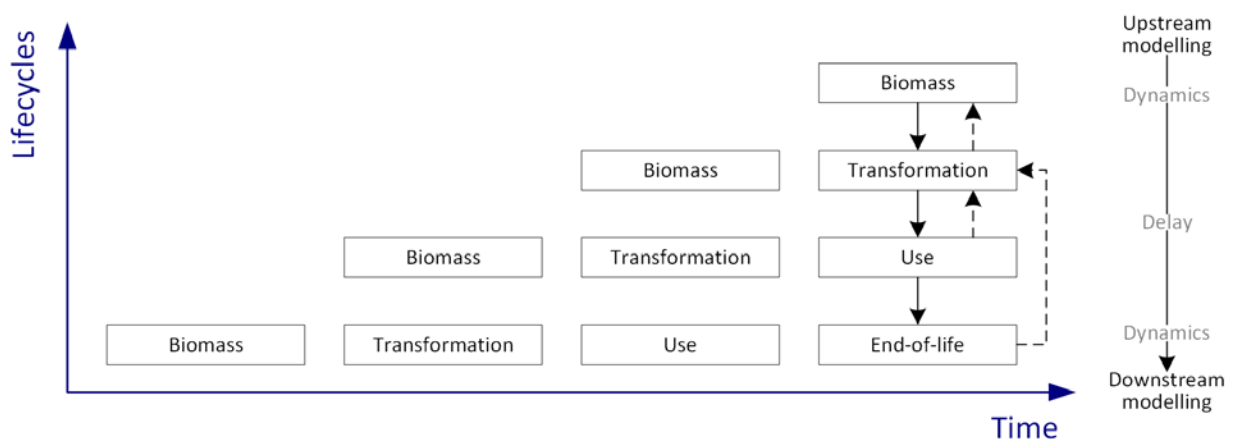

Fig. 3-5. Dynamic life cycles of biomass-based products featuring the classic phases associated with biomass extraction, transformation use and end-of-life and the inclusion of the time dimension (highlighted with the upwards file) at each phase from upstream to downstream modelling, whereas a emission delay (i.e. carbon storage) inbetween may emerge.

The abovementioned key features identify where dynamic carbon modelling plays an important role, and how to differentiate the carbon flows along the life cycle phases. However, the **use phase** is mainly characterised for delaying radiative forcing applicable to **long-lived products** (i.e. featuring a long service life), persisting in the technosphere over a longer period time (e.g. construction material), creating a **temporary carbon stock**. The delay does not *per se* represent a dynamic; however, it may have a considerable cooling effect, as the temporary stock avoids the return of C_{bio} to the atmosphere. Short-lived products (e.g. bioenergy), on the other hand, are not characterised by this feature.

As illustrated in Fig. 3-5, the key features for dynamic carbon modelling stress the **upstream and downstream** from the product's use phase, for which different dynamic elements need further consideration.

Upstream modelling

The upstream processes to be considered encompass all dynamic flows linked with the cultivation/production of biomass in agricultural (crops, perennial grasses) or forestry systems (including short rotation coppice). It is primarily concerned with the dynamic C_{bio} fixation and sequestration of biomass with long rotation lengths (growth time), over which incoming flows from the atmosphere are captured, as shown in Fig. 3-6.

Upstream modelling should also take into account the release flows from the biomass growth and cultivation, referring to decay or on-site combustion of dead biomass. Upstream systems include biowastes as contributors to SOC.

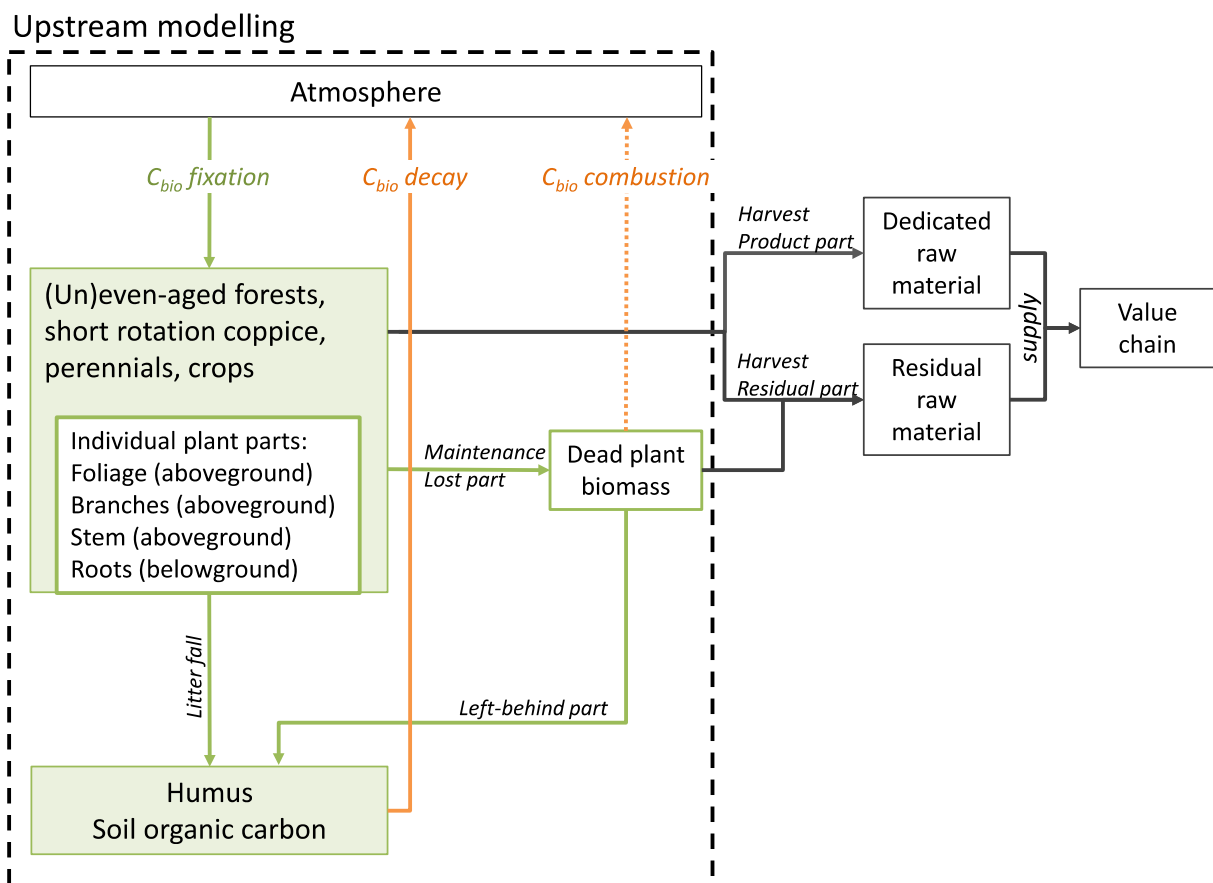

Fig. 3-6. Temporal consideration in biomass systems, upstream

When attempting dynamic modelling of biomass-based systems, several key modelling elements, listed in Table 3.1, should be accounted for.

Table 3.1. Key design questions in dynamic biomass-based carbon models

System/modelling aspects	Key data points
Sequestration and SOC modelling	How long is the rotation length?
	How many rotation cycles are accounted for?
	Are thinning/ trimming operations performed periodically or annually?
	Is the sequestration considered at stand, landscape or national/regional level?
	When does the initial/first sequestration flow start, i.e. is the sequestration accounted before or after the final harvest?
	How should the sequestration be allocated to the harvest activity? Or how should the first year of sequestration be defined?
	Is the biomass allowed to regrow after harvest?
Management practices	How to define a baseline situation ?
	How does forest residue removal affect soil organic carbon losses over time?
	What is the tree density or yield per unit of area or plot?
	What plant parts are exported/ harvested and what fractions are incorporated in the soil?
	Is the dead biomass left on the floor or exported as co-product?
Land cover and management changes	Is exogenous matter added as soil amendment or fertiliser?
	Is the current harvest affected by losses and mortalities?
	What was the previous land occupation?
	Is the current modelling system affected by changes in cover or management or in land use?
	Does the study aim at modelling indirect effects or externalities?

Downstream modelling

The downstream processes define when in time the EOL pathway of the bioproduct takes place. The EOL phase captures the last carbon release flow to the atmosphere (if applicable), which may take over several centuries.

The EOL biomass pathways may be explored individually (specific to a case) or through a combination of different scenarios to evaluate mitigation options. The European Commission promotes life-cycle thinking in the frame of European waste management policies under the Waste Framework Directive 2008/98/EC (EC, 2010). The Directive is targeted at developing a resource and energy efficient culture considering the waste hierarchy, in which waste prevention is the ultimate goal, followed by waste reuse/recycling and other forms of material or energy recovery, and as a last option waste disposal at the landfill site.

EOL scenario building may be inspired by the bio-cascading principle with the purpose of optimising the use of biomass products by displacing the emissions continuously before the final energy use, increasing the value of energy, as well as the exploring all possible EOL options (e.g. Odegard et al. (2012); Cowie et al. (2013)).

Temporal profiles of EOL pathway scenarios may be affected by net energy recovery and efficiencies, recycling loops (both closed- and open loops) (Schrijvers et al., 2016; Wolf and Chomkhamisri, 2014), as well as the generation of secondary materials entering other life cycles (e.g. fertilisers, soil amendment, animal feed, wood fibres, etc.), which avoid or displace the use of primary raw materials.

The EOL of most biogenic products takes place via waste management and wastewater treatment technologies, as well as via energy-recovery. For biofuels, the EOL is combustion for transport/mobility. The main EOL pathways of other non-transport bioproducts can be summarised exemplarily into seven modelling scenarios, combining different waste treatment processes (Fig. 3-7):

- Scenario 1 - Landfill without energy recovery: Waste is directly landfilled and/or buried. The landfill gas (LFG) is captured and burnt in flares to reduce GHG emissions; however, no energy recovery is performed. The remaining LFG (about 50-60% consisting of CH₄) is released into the atmosphere. Landfill leachate may be treated in the wastewater treatment plants (WWTP).
- Scenario 2 - Landfill with energy recovery: About 50% of LFG is captured and burnt in gas engines for energy recovery (electricity generation) at conversion efficiencies between 28-35% (Cherubini et al., 2009a). The remaining LFG is emitted to the atmosphere or partially flared. Landfill leachate may be treated is treated in the WWTP.
- Scenario 3 - Waste-to-energy: Separation of combustible waste fractions from the recyclable secondary materials, either from waste management or WWTP, and incineration of it. Technologies considered for incineration are thermal waste treatment process using fossil fuel to start-up the incineration process (without waste pre-treatment) for electricity and/or heat generation (Zaman, 2010). In the case of large organic waste fraction in the waste mixture the incineration is performed with high moisture content with lower energy recovery efficiencies (Mendes et al., 2004). The cleaning of the flue gas depends on the technology (water absorber or filters) and furnace type used for the incineration. Bottom ash is either landfilled or used as a road and cement aggregate.
- Scenario 4 - Recycling: Separation of combustible fraction (RDF-refused derived fuel) to recover energy (electricity production) from the recyclable secondary materials, either from waste management or wastewater treatment.
- Scenario 5 - Anaerobic Digestion: The organic wet fraction is pre-treated and used as feedstock in an anaerobic digester, under biological treatment processes. The generated biogas

is captured and used equivalent to natural gas for energy recovery (e.g. through combined heat and power- CHP). The by-product digestate is equivalent to chemical soil fertiliser or soil amendment.

- Scenario 6 - Composting by means of aerobic digestion: The organic fraction is composted under aerobic biological treatment processes, whereas CO₂ and CH₄ emissions are emitted into the atmosphere. The compost serves as soil amendment.
- Scenario 7 - incineration: energy generation by means of combustible waste fractions (RDF-refused derived fuel).

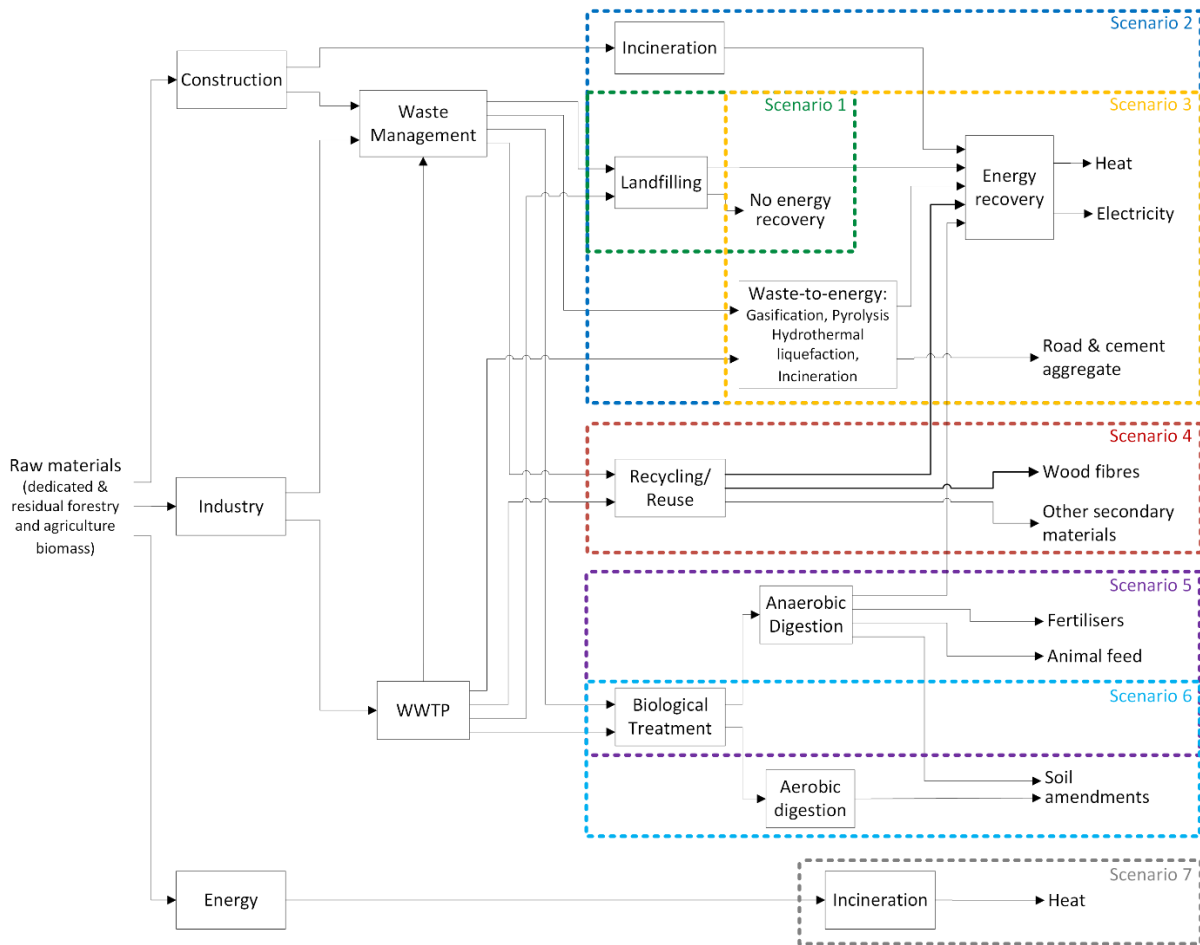

Fig. 3-7. Temporal consideration in biomass systems by means of scenarios, downstream

3.3.3 Dynamic LCIA: time-dependent characterisation factors

Having temporally disaggregated carbon exchange flows is an essential pre-condition to perform a dynamic impact assessment. The annualised dynamic inventories enable computing climate change impacts as a function of time by means of the **dynamic characterisation method** proposed by Levasseur et al., (2010a) (see section 2.5.6), and directly applicable with the dynCO₂ tool (Box 2-6).

This method is currently the most recognised and sophisticated approach in dynamic LCA, featuring both the annually differentiated GHG emission inventories and the time-dependent characterisation

with flexible/variable THs. The method allows consistency between temporal boundaries of the studied system by timing the emissions and the characterisation.

The main limitation of the dynamic method is the choice of a LCIA TH (end-year of the impact assessment or so called future reference year), which is unavoidable for comparison purposes, under for instance a policy context. When matching the study TH by means of LCIA TH and LCI TH being equal (see section 3.3.1) the radiative forcing effects from the last emissions are not considered into the future. Therefore, it is recommended to choose an end-year/reference future year of the dynamic impact assessment that goes beyond the last inventoried emission (i.e. LCIA TH > LCI TH).

Yet, in contrast to the static method, it allows testing the sensitivity of different TH choices and their influence on the results and mitigation options. Moreover, under consideration of no-TH the dynamic method allows following the evolution of the emissions and their radiative forcing effects, which can also be used for comparison of different temporal evolutions.

3.3.4 Life cycle interpretation

The interpretation of the results should be accompanied with a sensitivity analysis concerning the model parameters used for dynamic carbon modelling, or under comparison of the different potential temporal boundaries for LCI THs (e.g. timing of the sequestration, rotations, thinning operations, service life, etc.) and LCIA THs (i.e. setting different end-years of the dynamic impact assessment).

3.4 Simplified cradle-to-grave carbon cycle model example

3.4.1 Introduction

An exemplary case study of sawn mill wood co-products is presented here, supporting the proposed framework, to better understand the time dynamic LCA approach and its implementation in contrast with the currently used static classic LCA modelling one. For simplicity, the data for the life cycle processes derive exclusively from literature. In the absence of primary data, assumptions were built upon surveys and life cycle assessment inventory data from the Consortium for Research on Renewable Industrial Materials (CORRIM) and other studies from the Pacific Northwest region of the United States (Puettmann and Wilson 2005; Milota et al. 2006; Ingerson 2009; Bergman et al. 2012; Lippke and Puettmann 2013).

Fig. 3-8 shows a map of different timber assessment regions in the United States (Adams et al. 2006), highlighting the Pacific Northwest region selected for this example. The region belongs to the world's largest temperate rain forest biome (from Alaska to California). Annual softwood production rate of coniferous trees, amounts for 21 billion m³ (Puettmann and Wilson 2005). Among a large variety of products (e.g. glued-laminated timbers, plywood, and oriented strand board), structural lumber

accounts for 13% in this region, most of which is commonly used as structural wood framing in residential buildings.

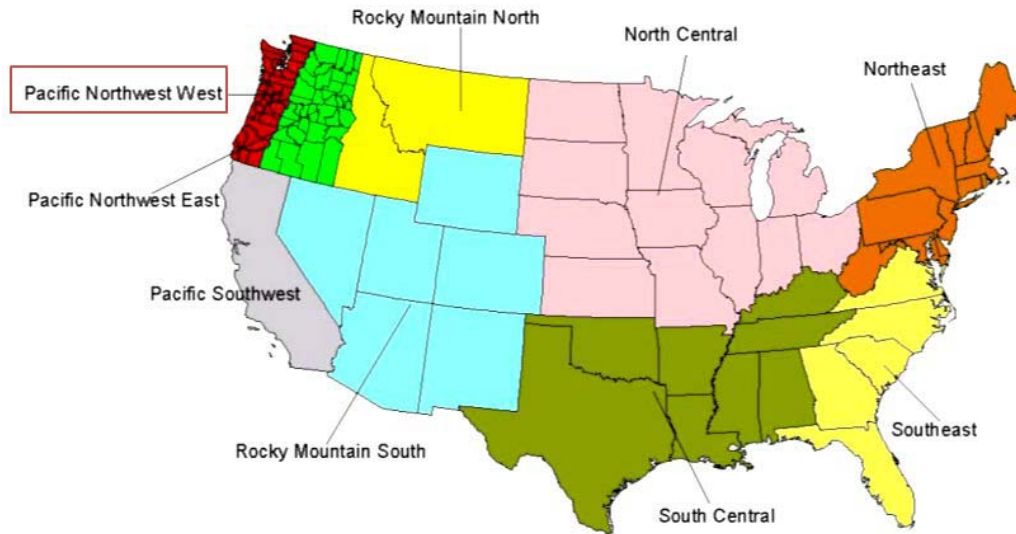

Fig. 3-8. U.S. Forest Service Resources Planning Act timber assessment regions (Adams et al. 2006)

3.4.2 Goal and scope

The purpose of this study is to model the dynamic biogenic carbon (C_{bio}) balance of a multifunctional sawmill production system by contrasting: a) main product lumber, and b) co-production lumber and wood chips. The functional unit is one tonne of biogenic carbon (1 t C_{bio}) sequestered and released over time. The primary aim of this assessment is to draft a simple modelling approach of the products' life cycle, capturing the years of 1 t of C_{bio} sequestration in the biomass over a given rotation length, and the subsequent years when that same unit of 1 t of C_{bio} embedded in the wood biomass is released to the atmosphere and/or delayed and/or stored. The atmospheric impact from C_{bio} release flows are mass allocated to the lumber only or for the co-production respective to their proportional contributions.

The two C_{bio} balances are expressed in their respective biogenic-sourced GHG emissions (here C_{bio-CO_2} and C_{bio-CH_4}) to convert them into dynamic GHG inventories and assess their time-dependent effects on the atmospheric GHG concentration, by means of the dynamic method proposed by Levasseur et al. (2010). The dynamic results are compared with the classical static LCA approach using the IPCC Global Warming Potential (GWP) factors for both THs 20 and 100 years (Myhre et al. 2013a).

The scope of the example encompasses exclusively C_{bio} flows throughout the entire products life cycle, from cradle-to-grave (upstream to downstream) processes, namely: coniferous forest growth, log harvest, lumber manufacture with on-site energy generation at the sawn mill and wood chip co-production, assembly of the frame structure and landfill disposal with no energy recovery.

The main life cycle phases linking processes and mass flows (in percentage) of lumber and co-production are illustrated Fig. 3-9. Throughout the phases, the time-dynamic emission flows can be described: i.e. carbon fixation and sequestration (by forest tree growth dynamic and rotation length) and carbon releases instantly or gradually distributed over time. The dynamic carbon balance (LCI) consists exclusively of temporally differentiated C_{bio} flows. Fossil-sourced carbon, any carbon losses within the life cycle processes, as well as other LCA inventories (e.g. resource and energy consumption, emissions, etc.) are excluded from this example, as the primary aim lies in the accounting of the lifetime of 1 t C_{bio} flows through all given life cycle stages.

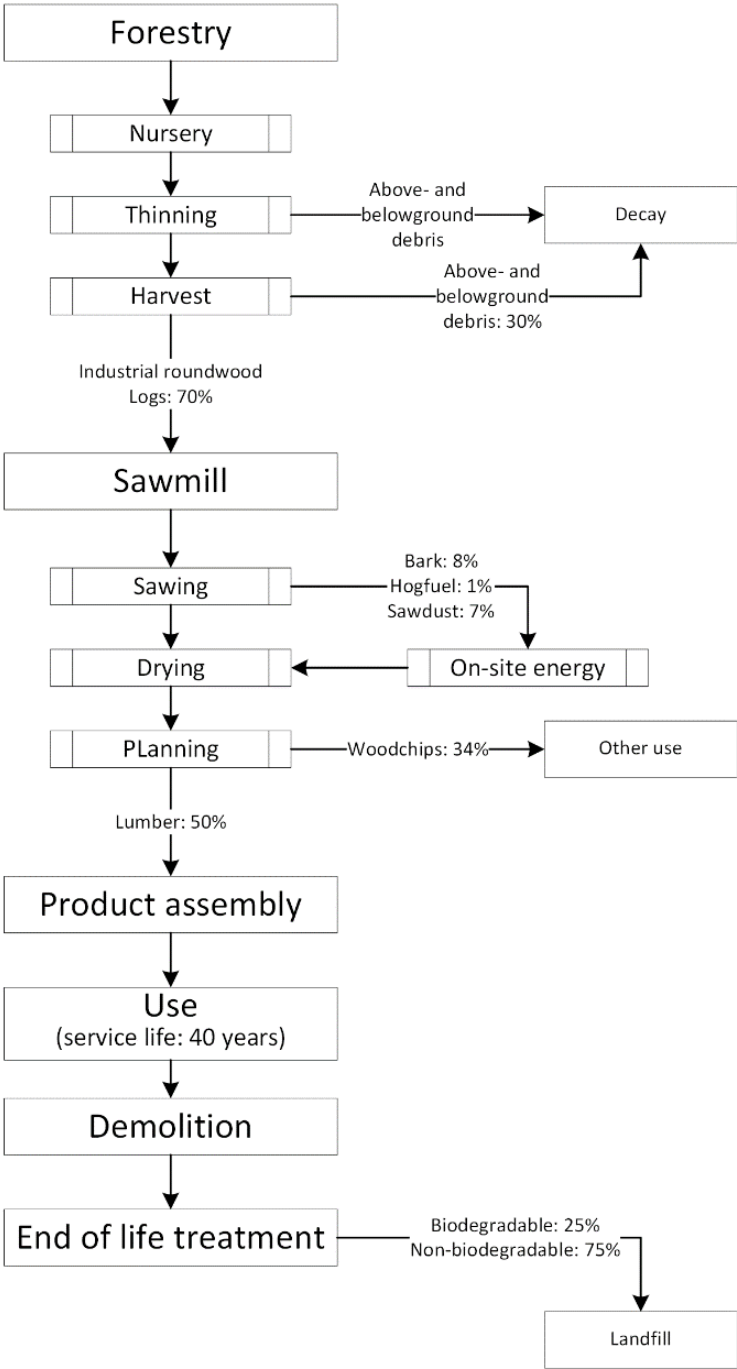

Fig. 3-9. Life cycle processes of wood construction materials with assumptions undertake

Temporal emission profiles

The dynamic C_{bio} flows are described with one-year time steps. The temporal emission profiles are dependent on the timing of the emission occurrence primarily determined throughout the main life cycle phases, detailed as follows:

- Forestry: 1 t of C_{bio} is fixed in the tree biomass (i.e. up-taken through photosynthesis during growth) over a 45-year rotation length (from t_0 to t_{45}). Note that the sequestration cycle of 45 years has been arbitrarily chosen to represent a forest management of a medium intensity class with fertilisation (represented by 46% in the Pacific Northwest region) (Bergman et al. 2012). In the subsequent year (t_{46}), the logs are harvested. The logging process generates 0.3 t C_{bio} of forest residues, of which 50% consists of aboveground biomass (e.g. litter, limbs) and 50% belowground (e.g. stump, roots). It is assumed both compartments undergo decay, whereas $C_{\text{bio}}\text{-CO}_2$ emissions only are considered.
- Sawmill: the round wood logs are processed into 0.5 t C_{bio} kiln-dried lumber. 0.16 t C_{bio} of the sawn wood waste (bark, hog fuel and sawdust) is burned in tank on-site boiler for the wood drying process. Moreover, 0.34 t C_{bio} of an economic valuable co-product (wood chips) is generated. The wood chips are assumed to be burned within the t_{46} . For combustion-related emissions we considered $C_{\text{bio}}\text{-CO}_2$ only.
- Use: it is assumed that lumber assembled (it was assumed that no residues were generated during assembly) for structural house framing has a service life of 40 years (from t_{46} to t_{86}), and that no C_{bio} emissions are released over the entire use phase.
- End of life treatment (disposal): at the end of the service life, the residential framing structure is demolished (it was assumed that 100% of the wood is recovered during demolition) and landfilled as wood waste, of which 25% is presumed to be degradable organic carbon, undergoing aerobic and anaerobic decay, converted into landfill gas without energy recovery, consisting of 60% $C_{\text{bio}}\text{-CH}_4$ and 40% $C_{\text{bio}}\text{-CO}_2$ (Börjesson and Gustavsson 2000). The non-decomposable portion (75%) remains in the landfill, representing a permanent carbon stock.

Carbon modelling approach

A summary of all assumptions, including key years, is illustrated in Fig. 3-10.

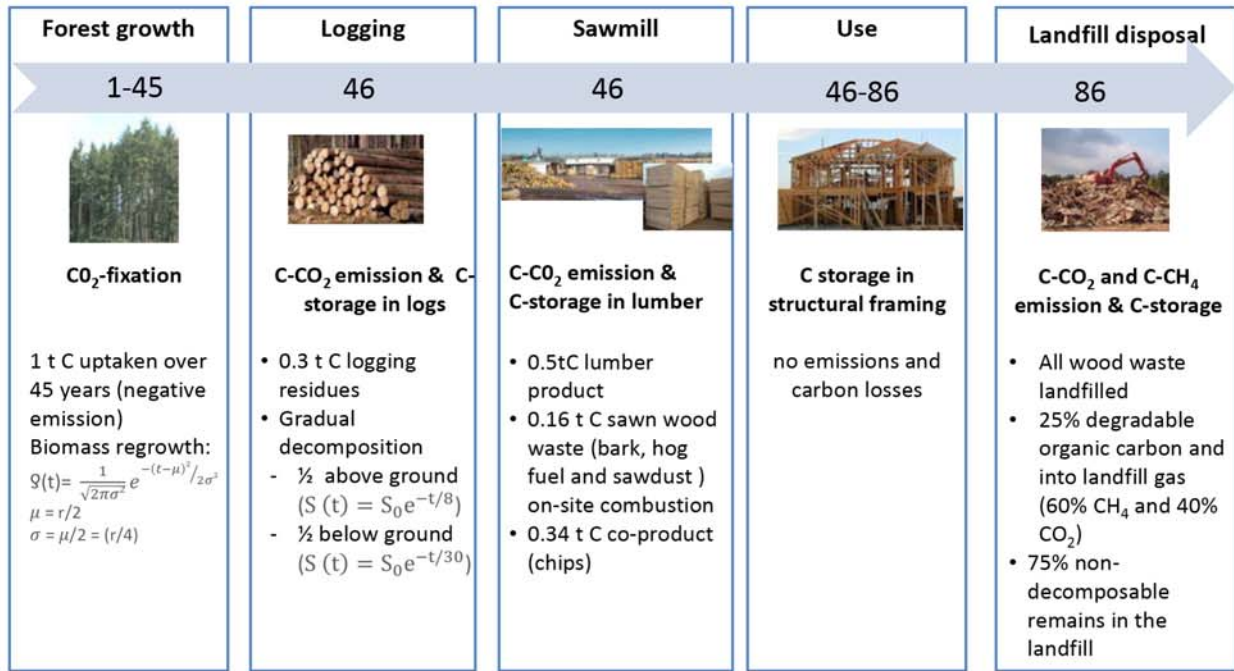

Fig. 3-10. Overview of assumptions undertaken for dynamic modelling of one tonne of biogenic carbon (C_{bio})

For simplicity, forest tree growth and thus CO₂ fixation into the biomass was modelled by means of the Gaussian normal distribution function $g(t)$ Eq. 3-1, as previously done by Cherubini et al. (2011), in the GWP_{Bio} metric (see section 2.5.5).

$$g(t) = \frac{1}{\sqrt{2\pi\sigma^2}} e^{-\frac{(t-\mu)^2}{2\sigma^2}} \quad \text{Eq. 3-1}$$

where the mean μ represents the year of maximum CO₂ fixation (estimated at half a rotation cycle $\mu = r/2$) and the variance σ stands for the width of distribution (estimated at $\sigma = \mu/2$).

The decay of embedded C_{bio} in the wood biomass is estimated following the first order exponential decay equation Eq. 3-2 (Cornillier and Benoist 2015):

$$S(t) = S_0 e^{-t/\tau} \quad \text{Eq. 3-2}$$

with an average lifespan τ (half-life) estimated at 8 years for above- and 30 years for below-ground logging residues (Montes and Cañellas 2006).

3.4.3 Dynamic LCI

Dynamic life cycle inventory time horizon

The detailed description of the temporal emission profiles allows defining a dynamic LCI TH of the C_{bio} balance. The emissions from the last life cycle stage (i.e. landfilling) start at t_{86} ; however, the decaying $C_{\text{bio}}\text{-CH}_4$ and $C_{\text{bio}}\text{-CO}_2$ are continuously released to the atmosphere over longer time lengths. To avoid temporal cut-offs, the chosen LCI TH is long enough to cover all C_{bio} flows. Consequently, the LCI TH is set from t_0 to t_{200} , given that the decaying emissions for the two systems accounts for $1\text{E-}4 t C_{\text{bio}}$ at t_{200} , here considered close enough to zero.

Visualisation of inventory results

Fig. 3-11 provides a detailed overview of such dynamic C_{bio} inventories concerning lumber (Fig. 3-10a) and the co-production (Fig. 3-10b), visualising when in time the carbon emissions take place. C_{bio} fixed and cumulated in the tree biomass from year t_0 to t_{45} , as well as the C_{bio} stock in the landfill at t_{86} is computed as negative. All release emissions (from year 46 onwards) are computed as positive. Combustion of sawdust from onsite co-generation processes are released instantly (one $C_{\text{bio}}\text{-CO}_2$ -pulse at t_{46}), while decay emissions gradually ($C_{\text{bio}}\text{-CO}_2$ starting at t_{46} due to logging operations and $C_{\text{bio}}\text{-CO}_2$ and $C_{\text{bio}}\text{-CH}_4$ at t_{86} due to EOL landfilling), both decreasing over time towards equilibrium.

The main difference between the two C_{bio} balances (lumber and co-production) are the $C_{\text{bio}}\text{-CO}_2$ releases, including decay-related, at the sawmill (t_{46}) and landfill (from t_{86} onwards), which are higher by about 31% for co-production (Fig. 3-10b) due to the accounted wood chip combustion. On the other hand, the co-production reveals lower decay emissions by 41%. This is due to the mass-allocation in the lumber case (Fig. 3-10a), which attributes a higher C_{bio} contribution to the EOL than in the co-production.

Account needs to be taken for a given **permanent C_{bio} stock** at the EOL landfill phase, not shown in Fig. 3-11. The flow cannot be inventoried as negative, to **avoid double-counting**, as the value is already proportionally accounted for in the total C_{bio} sequestration. Moreover, it is **not accountable** as positive, as it does not represent a release flow to the atmosphere. In this example, the C_{bio} remains in the technosphere. Therefore, the stock flow is excluded from the impact assessment, but noted as a reduction of outflowing carbon from the technosphere (favouring climate change mitigation).

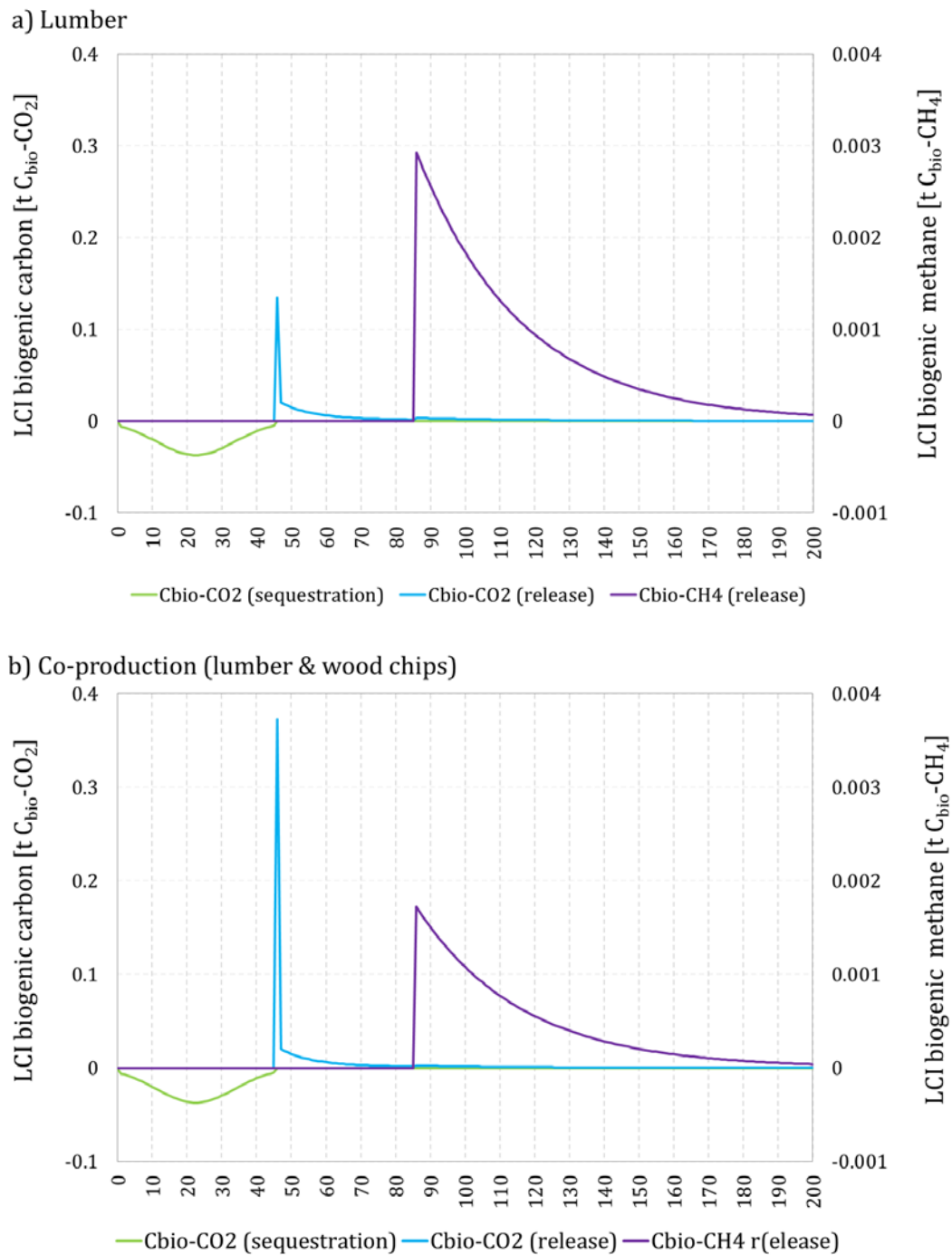

Fig. 3-11. Dynamic LCI results of both emissions biogenic CO₂ (in red, left-handed y-axis) and biogenic CH₄ (in blue, right-handed y-axis) from the cradle-to-grave lumber product [$t C_{bio}$]

Sensitivity of inventory results to temporal cut-offs

To test the sensitivity of the TH selection at the inventory level, three different LCI TH are compared, namely t_0-t_{86} , t_0-t_{100} and t_0-t_{200} . Table 3.2 and Table 3.3 shows all cumulative negative (C_{bio-CO_2}) and positive (C_{bio-CO_2} and C_{bio-CH_4}) flows over the defined LCI THs. The negative C_{bio} sequestration is the same in all LCI THs, as the fixation occurs from year t_0-t_{45} . The positive C_{bio} releases, on the other hand, increase with increasing LCI TH, except for the permanent C_{bio} stock (single value at t_{86}). The

stock flow will be excluded from the assessment, but for checking the net zero C_{bio} balance, that is to say, the dynamic input flows (1 t C_{bio}) of sequestration is equal to all dynamic output and/or stock flows (1 t C_{bio}).

The net C_{bio} balance in Table 3.2 and Table 3.3 is not equal to zero for the LCI THs of total 86 and total 100 years. Thus, the longer time length reduces the temporal cut-offs from the inventory, as more or almost all C_{bio} flows covered –i.e. not temporal cut-offs of inventories. Moreover, even though the net C_{bio} balance decreases with increasing LCI TH, the values are higher for the lumber than for the co-production in t_{86} and t_{100} by +30% and -28% respectively, because i) the C_{bio} -CO₂ emission releases from combustion are higher for the co-production (single pulse emission), and ii) C_{bio} -CH₄ releases from EOL landfill gas are higher for lumber, due to mass allocation.

Table 3.2. Biogenic carbon flows and net balance for lumber over three life cycle inventory time horizons

LCI TH	C_{bio} -CO ₂ sequestration	C_{bio} -CO ₂ release	C_{bio} -CH ₄ release	C_{bio} -CO ₂ stock (landfill)*	Net C_{bio} balance
86 years	-1.00	0.37	0.00	(0.45)	-0.18
100 years	-1.00	0.41	0.04	(0.45)	-0.11
200 years	-1.00	0.47	0.09	(0.45)	0.00

* value shown for checking net zero balance, but excluded from the impact assessment

Table 3.3. Biogenic carbon flows and net balance for co-production over three life cycle inventory time horizons

LCI TH	C_{bio} -CO ₂ sequestration	C_{bio} -CO ₂ release	C_{bio} -CH ₄ release	C_{bio} -CO ₂ stock (landfill)*	Net C_{bio} balance
86 years	-1.00	0.61	0.00	(0.26)	-0.12
100 years	-1.00	0.64	0.02	(0.26)	-0.08
200 years	-1.00	0.68	0.05	(0.26)	0.00

* value shown for checking net zero balance, but excluded from the impact assessment

3.4.4 Dynamic LCIA

The C_{bio} balance requires conversion into their respective GHG emissions, CO₂ and CH₄ multiplying by 44/12 and 44/16 respectively. The potential climate change effects are assessed by means of both static and dynamic LCIA methods, using the relative equivalent climate change metric, expressed in t CO₂-eq.

Dynamic life cycle impact assessment time horizon

For the static assessment, the GWP metric over 20 and 100 years is chosen. The same references LCIA THs are retained for the dynamic impact assessment. However, to make the dynamic approach comparable with the static, time coherent LCIA THs have are determined. It implies that to overall

dynamic LCIA TH, previously set to 200 years in total to avoid temporal inventory cut-offs, needs to be extended by 20 and 100 years. Thus, coherent dynamic LCIA TH (coherent with the static applications) results in 220 and 300 years, as shown in Fig. 3-12.

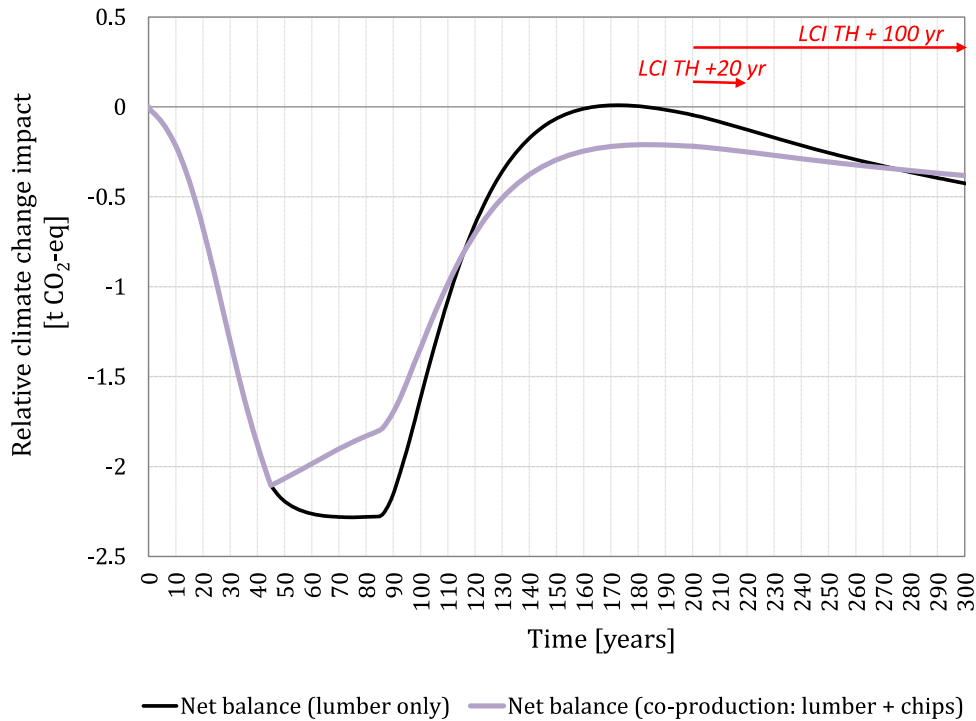

Fig. 3-12. Dynamic impact assessment of the lumber and co-production system denoting LCIA TH of 220 and 300 years

Comparison of static and dynamic approaches

The quantitative results of static and dynamic impact assessment approaches for the lumber and the co-production are shown in Table 3.4 and Table 3.5 respectively. The results are provided here for sequestration and releases as well as for the net balance of all C_{bio} flows.

The overall results do not differ considerably for the sequestration between static and dynamic approaches and between the two LCIA THs, but, considerably more for the releases, particularly C_{bio} - CH_4 related, consequently reflected on the net balance. Comparing static and dynamic CO_2 -eq results from C_{bio} - CO_2 releases, C_{bio} - CH_4 releases and the net balance, the impacts differ for lumber and co-production by about 20%, 80% and 100% respectively with LCIA TH 20; and by 20%, 50% and 150% respectively with LCIA TH 100.

Table 3.4 Static vs dynamic climate change impacts of lumber over impact time horizon of 20 and 100 years

LCIA approach	LCIA TH	LCI TH	C _{bio} -CO ₂	C _{bio} -CO ₂	C _{bio} -CH ₄ Net balance	
			sequestration	release	release	
			t CO ₂ -eq	t CO ₂ -eq	t CO ₂ -eq	t CO ₂ -eq
Static	LCIA TH 20	0	-3.667	1.721	9.784	7.838
Dynamic	LCIA TH = LCI +20	200	-3.380	1.305	1.949	-0.126
Static	LCIA TH 100	0	-3.667	1.721	3.261	1.316
Dynamic	LCIA TH = LCI TH +100	200	-3.458	1.421	1.613	-0.424

C_{bio}: biogenic carbon, CO₂: carbon dioxide, CH₄: methane, LCI: life cycle inventories, TH: time horizon

Table 3.5 Static vs dynamic climate change impacts of co-production over impact time horizon of 20 and 100 years

LCIA approach	LCIA TH	LCI TH	C _{bio} -CO ₂	C _{bio} -CO ₂	C _{bio} -CH ₄ Net balance	
			sequestration	release	release	
			t CO ₂ -eq	t CO ₂ -eq	t CO ₂ -eq	t CO ₂ -eq
Static	LCIA TH 20	0	-3.667	2.506	5.753	4.592
Dynamic	LCIA TH = LCI +20	200	-3.380	1.984	1.146	-0.250
Static	LCIA TH 100	0	-3.667	2.506	1.918	0.757
Dynamic	LCIA TH = LCI TH +100	200	-3.458	2.128	0.948	-0.381

C_{bio}: biogenic carbon, CO₂: carbon dioxide, CH₄: methane, LCI: life cycle inventories, TH: time horizon

Fig. 3-13 shows a direct comparison of the impact results for lumber and co-production over the different LCIA THs of 20 and 100 years, previously listed in Table 3.4 and Table 3.5. There is no difference for sequestration values between lumber and co-production systems per assessment approach and LCIA TH. However, CO₂-eq results from co-production across approaches and LCIA THs have higher impacts by about 30% associated with C_{bio}-CO₂ release, and lower impacts by about 40% from C_{bio}-CH₄ releases.

For the net balance results between lumber and co-production, the static results differ by about 40% for both LCIA THs, however the dynamic impacts by 50% and by 10% at LCIA TH 20 and 100 years respectively.

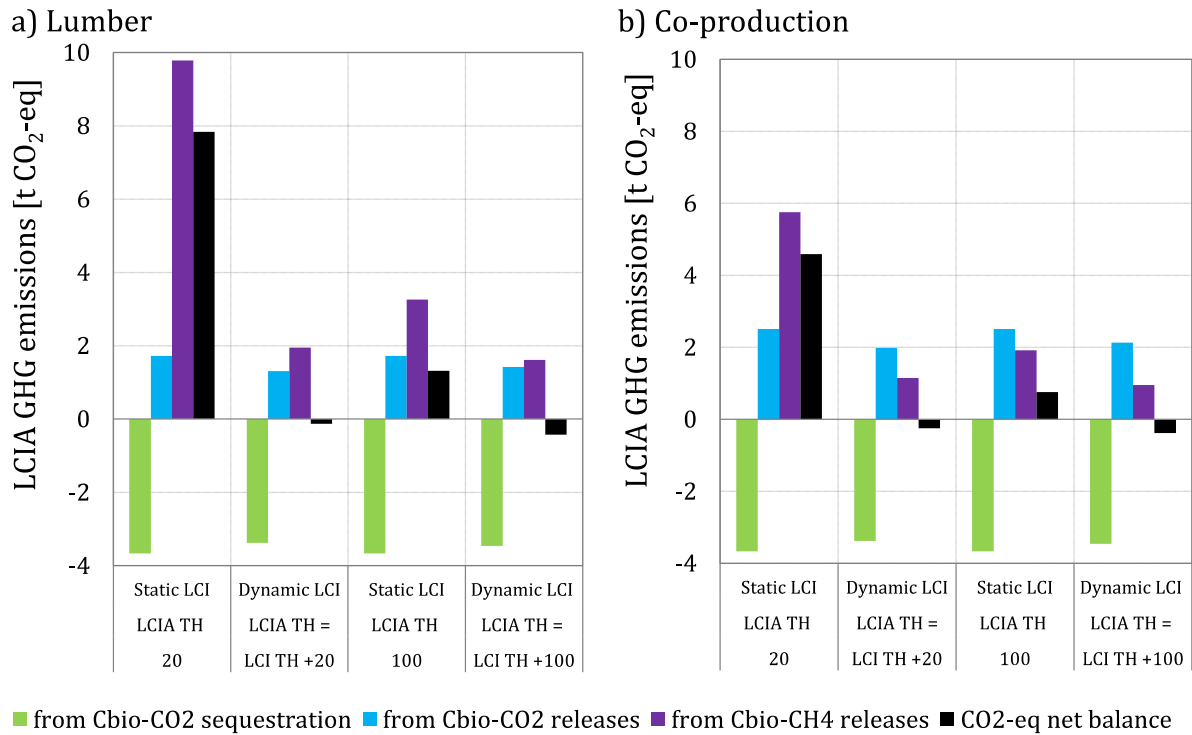

Fig. 3-13. Static and dynamic impact assessment of lumber and co-production over LCIA THs 20 and 100 years

Long-term effects

Even though both approaches are compared with a coherent LCIA TH, the static and dynamic impact results are considerably different. The main difference between both approaches is given in the net balance results, which are negative for dynamic and positive for static approaches.

Why are the forcing effects of the C_{bio} balance negative, in the dynamic approach? As shown in Fig. 3-12, the negative forcing effects never really reach positive values. The negative values from the sequestration are reduced due to the positive releases up to a peak between the t_{160} and t_{180} , where the values are close to zero for co-production and zero for the lumber case. The lumber reveals higher impacts as the co-production; however, the curve drops again to the same values as co-production t_{280} .

The setting of a very long-term LCIA TH, for instance over 500 years —as shown in Fig. 3-14— allows following the course of the curve. The long-term time perspective denotes the decreasing forcing effects related with the permanent C_{bio} stock, not accounted for in the assessment, but resulting from the unbalanced returns to the atmosphere, i.e. 1 t C_{bio} sequestration (as input) and 0.55 or 0.74 t C_{bio} releases (as outputs) for lumber or co-production respectively.

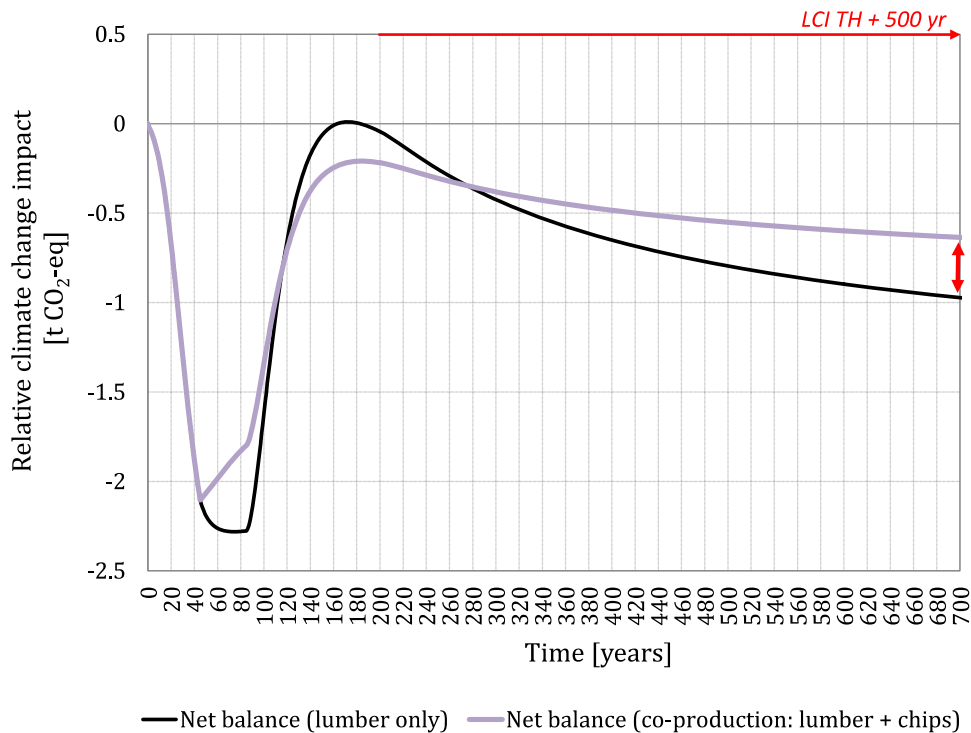

Fig. 3-14. Long-term dynamic forcing effects over a LCIA TH of 500 year of lumber and co-production

3.4.5 Interpretation and conclusions

Under the classic static LCA approach, no timing of the emission occurrence is taken into consideration, due to the aggregation of all emission flows. The carbon neutral approach relies on the same method, hypothesising that the C_{bio} balance is zero, as the same unit of C_{bio} fixed from the atmosphere into the plant biomass will be emitted back to the atmosphere.

Under consideration of the temporal dimension, the carbon neutral assumption may only be valid when the considered C_{bio} sequestration and release flows take place in the same year (e.g. use of biomass from specific annual crops), and no gradual decay releases are accounted for at the upstream (e.g. by ignoring SOC flows from dead above- and belowground biomass).

The illustration of this simplified carbon cycle example demonstrates that radiative forcing effects are time-dependent and therefore the timing of the emission occurrence is relevant, particularly when the biomass-sourced product (here lumber material and bioenergy from wood chips and sawdust) has:

- Long rotation lengths (here forest wood growth over 45 years).
- Long service life (here structural framing of residential buildings with service life of 40 years).
- Temporally differentiated EOL pathways (energy co-generation at t_{46} and gradual decay partially from t_{46} at forest field and from t_{86} at landfill).

Moreover, the accounting for other non- CO_2 GHG emissions has relevant implications. The $C_{\text{bio}}\text{-CH}_4$, for instance, is a short-lived gas, whose radiative forcing effects are higher than long-lived CO_2 with

very long atmospheric perturbation time. The use of the static relative impact method implies that the forcing effects decrease with increasing LCIA TH (i.e. end-year of the impact assessment far into the future) or vice versa the shorter the impact assessment time length the higher the effects. The values are relativised by 1 given that CO₂ is the reference gas whose characterisation factor is always 1 in the static approach.

The climate effects are not accurately assessed under the static characterisation applying the IPCC GWP impact factors. The static results are inconsistent with i) the LCI TH, because the emissions are characterised the same way, as no timing is considered, ii) and the impact representation based on the fixed LCIA TH, because each emission is integrated over 20 or 100 years and thus the effects are further shift in time.

Thus, the time-aggregated values and the fixed LCIA TH deliver inconsistent and biased results. From the example with lumber and co-production, it was identified that the last release takes place in the year 200. The integration with the static approach over 20 or 100 years would actually represent the forcing effects for the year 220 or 300 respectively. That is the reason why the dynamic LCIA TH was aligned to the static representation of results to consistently compare both static and dynamic impacts. The dynamic approach, on the other hand, does not depend on any TH. The characterisation is thus consistency in terms of the inventoried temporal boundaries of the LCI TH and variable/flexible LCIA TH of the impact assessment.

To conclude, the dynamic method allows a better representation of climate change impacts from biomass-based products, however, setting the temporal boundaries is unavoidable and needs to be defined with precaution, particularly concerning temporal cut-offs. In this example it was shown that in the downstream phase, C_{bio} is partially and permanently stocked in the landfill. Excluding the EOL treatment final C_{bio} releases and/or stocks are ignored. Thus, the final results on the chosen TH and its sensitivity.

References for 3.4

- Adams, D.M., Haynes, R.W., Daigneault, A.J., 2006. Estimated Timber Harvest by U.S. Region and Ownership, 1950-2002. United States Department of Agriculture, Forest Service, Pacific Northwest Research Station.
- Bergman, R.D., Salazar, J., Bowe, S., 2012. Developing a dynamic life cycle greenhouse gas emission inventory for wood construction for two different end-of-life scenarios, in: International Symposium on Life Cycle Assessment and Construction. Nantes, France, pp. 318–325.
- Börjesson, P., Gustavsson, L., 2000. Greenhouse gas balances in building construction: Wood versus concrete from life-cycle and forest land-use perspectives. *Energy Policy* 28, 575–588. [https://doi.org/10.1016/S0301-4215\(00\)00049-5](https://doi.org/10.1016/S0301-4215(00)00049-5)

- Cherubini, F., Bargigli, S., Ulgiati, S., 2009. Life cycle assessment (LCA) of waste management strategies: Landfilling, sorting plant and incineration. *Energy* 34, 2116–2123. <https://doi.org/10.1016/j.energy.2008.08.023>
- Cherubini, F., Peters, G.P., Berntsen, T., Strømman, A.H., Hertwich, E.G., 2011. CO₂ emissions from biomass combustion for bioenergy: atmospheric decay and contribution to global warming. *GCB Bioenergy* 3, 413–426. <https://doi.org/10.1111/j.1757-1707.2011.01102.x>
- Cornillier, C., Benoist, A., 2015. Etude préliminaire à la réalisation de bilans environnementaux sur le chauffage au bois – Partie 2 : Mise en œuvre de méthodes de caractérisation d’impact sur le changement climatique, ADEME. ADEME-Agence de l’environnement et de la maîtrise de l’énergie. Paris.
- Cowie, A., Berndes, G., Smith, T., 2013. On the timing of greenhouse gas mitigation benefits of forest-based bioenergy. ExCo:2013:04. IEA Bioenergy. Dublin.
- EC, 2010. Being wise with waste: the EU’s approach to waste management. 2010. <https://doi.org/10.2779/93543>
- Ingerson, A., 2009. Wood Products and Carbon Sequestration: Can Increased Production Help Solve the Climate Crisis? The Wilderness Society. The Wilderness Society, Washington, D.C.
- ISO, 2006a. ISO 14040 Environmental management — Life cycle assessment — Principles and framework. The International Standards Organisation. Geneva.
- ISO, 2006b. ISO 14044 Environmental management — Life cycle assessment — Requirements and guidelines. The International Standards Organisation. Geneva.
- Levasseur, A., Lesage, P., Margni, M., Deschênes, L., Samson, R., 2010. Considering time in LCA: Dynamic LCA and its application to global warming impact assessments. *Environ. Sci. Technol.* 44, 3169–3174. <https://doi.org/10.1021/es9030003>
- Lippke, B., Puettmann, M.E., 2013. Life-cycle carbon from waste wood used in district heating and other alternatives. *For. Prod. J.* 63, 12–23. <https://doi.org/10.13073/FPJ-D-12-00093>
- Mendes, M.R., Aramaki, T., Hanaki, K., 2004. Comparison of the environmental impact of incineration and landfilling in São Paulo City as determined by LCA. *Resour. Conserv. Recycl.* 41, 47–63. <https://doi.org/10.1016/j.resconrec.2003.08.003>
- Milota, M.R., West, C.D., Hartley, I.D., 2006. Gate-To-Gate Life-Cycle Inventory of Softwood Lumber Production. *Wood Fiber Sci.* 37, 47–57.
- Montes F, Cañellas I. Modelling coarse woody debris dynamics in even-aged Scots pine forests. *For Ecol Manage* 2006;221:220–32. <https://doi.org/10.1016/j.foreco.2005.10.019>.
- Myhre, G., Shindell, D., Bréon, F.-M., Collins, W., Fuglestedt, J., Huang, J., Koch, D., Lamarque, J.-F., Lee, D., Mendoza, B., Nakajima, T., Robock, A., Stephens, G., Takemura, T., Zhang, H., 2013. Chapter 8 Anthropogenic and Natural Radiative Forcing, in: Stocker, T.F., Qin, G.-K., Plattner, M., Tignor, S.K., Allen, J., Boschung, A., Nauels, Y., Xia, V.B. and P.M.M. (eds.). (Ed.), In: *Climate Change 2013: The Physical Science Basis. Contribution of Working Group I to the Fifth Assessment Report of the Intergovernmental Panel on Climate Change* [Stocker, T.F., Qin, G.-K., Plattner, M., Tignor, S.K.

Chapter 3: A framework for dynamic carbon modelling

Allen, J. Boschung, A. Nauels, Y. Cambridge University Press, Cambridge, United Kingdom and New York, pp. 659–740. <https://doi.org/10.1017/CBO9781107415324.018>

Odegard, I., Croezen, H., Bergsma, G., 2012. Cascading of Biomass: 13 Solutions for a Sustainable Bio-based Economy: Making Better Choices for Use of Biomass Residues, By-products and Wastes. Delft.

Schrijvers, D.L., Loubet, P., Sonnemann, G., 2016. Developing a systematic framework for consistent allocation in LCA, *International Journal of Life Cycle Assessment*. <https://doi.org/10.1007/s11367-016-1063-3>

Wolf, M.-A., Chomkamsri, K., 2014. The “Integrated formula” for modelling recycling , energy recovery and reuse in LCA - White paper. White Pap.

Zaman, A.U., 2010. Comparative study of municipal solid waste treatment technologies using life cycle assessment method. *Int. J. Environ. Sci. Technol.* 7, 225–234. <https://doi.org/10.1007/BFe>

3.5 Chapter conclusion

This chapter introduced a framework for dynamic carbon modelling, providing details on how to account for temporal C_{bio} emission profiles from forestry resources, how to avoid temporal inventory cut-offs and how to compare dynamic with static impact results, alongside a simplified cradle-to-grave example.

The results have shown the importance of developing dynamic C_{bio} balances built on annual C_{bio} sequestration and C_{bio} release flows along the entire life cycle of a bioproduct. The EOL phase showed that eventually not all embedded C_{bio} embedded in the lumber bioproduct does return to the atmosphere. Thus, it is essential to perform a full lifetime dynamic C_{bio} accounting to capture all carbon exchanges with the atmosphere through time.

However, the sequestration curve in the cradle-to-grave example was approximated by means of the Gaussian function, which does not accurately represent the dynamic growth curve of trees (as reviewed in section 2.6.1). It introduces bias in the timing of sequestration flows of forest biomass with long-term rotation lengths, and thus misinforms on the actual radiative forcing effects.

The elements of the proposed framework are addressed in detail in subsequent chapters, via scientific articles, as depicted in Fig. 3-15. The papers focus on specific elements, differentiated by colour.

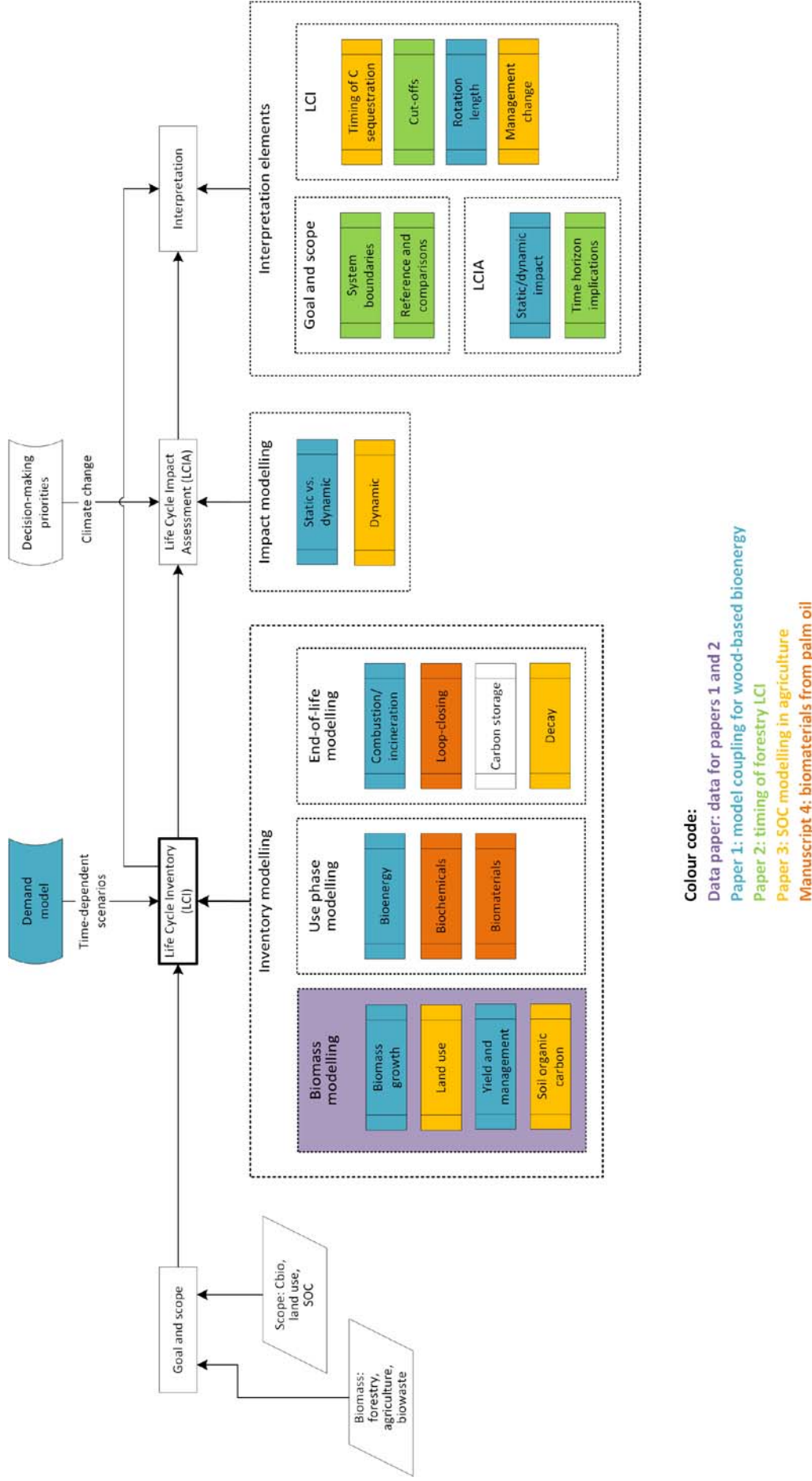

Fig. 3-15. Links among papers and framework elements (the thesis paper assigned to each subject was that where the subject was explored in more detail)

Chapter 4:

Forestry: growth modelling

4 Forestry: growth modelling

4.1 Chapter context

This chapter deals primarily with modelling C_{bio} sequestration dynamic of forestry systems. The objective is to develop a dynamic modelling framework for time-dependent forest C_{bio} sequestration (i.e. annual stocking factors) and its application to bioenergy inventories. The main emphasis lies on upstream modelling, involving C_{bio} accumulating in the biomass as a function of time by means of non-linear tree growth modelling of different tree species with different rotation lengths and management practices. The consideration temporal dynamic in the modelling of wood-to-bioenergy pathways compared with the classical static approaches are expected to deliver a better understanding for valuing C_{bio} in forest-sourced bioenergy.

The papers in this chapter respond to the dynamic modelling and impact assessment questions and implications under the consideration of the time dimension, further discussed in the interpretation of the results. The framework elements (Chapter 3) addressed by Paper 1 and Paper 2 and their associated materials (Appendix D: Data paper on forest models) are indicated in Fig. 3-15.

All forest C_{bio} sequestration modelling details are compiled in the **Data paper** to inform on non-linear forest tree growth dynamic and management practices, and thus delivering the necessary data pre-treatment and data inputs to the dynamic computation of C_{bio} sequestration models. The annual flows are expressed in $\text{t } C_{\text{bio}} \cdot \text{yr}^{-1}$ per t of forest wood consumed for bioenergy. The forest models cover the main tree species of the wood supply chain in France. Approximately 31% (16.9 million hectares) of the French territory is forest, standing for the second most important land-use after agricultural and grassland, occupying 57% of the territory. Three-quarters of the forest area in France is privately-owned and the remaining is public/ communal. The distribution per forest area coverage is primarily represented by broadleaved/deciduous (64%) and conifers/evergreen (36%) trees. Half of the population in forest stands is monospecific (single species stands) and the other half are mixed stands of two-species (33%), three species (12%) and four or more species (4%) (IGN, 2017).

Paper 1 proposes a coupling approach with a partial-equilibrium model (see classification in Box 2-5) to evaluate prospective energy-transport scenarios under the consideration of the forest wood commodity outputs and develop dynamic wood C_{bio} balances, included in the carbon footprint inventories. The same coupling framework is applied in **Paper 2**, however, with the purpose discussing modelling implementation challenges of forest C_{bio} , particularly concerning the setting of the initial sequestration flow (chicken-egg dilemma). Thus, each paper responds to different research questions, detailed as follows:

Paper 1 (section 4.2):

Chapter 4: Forestry: growth modelling

- How are the final static climate change results of the energy-transport system affected by the dynamic forest-sourced C_{bio} balances?
- Do the results with C_{bio} balances considerably differ by changing the system boundary, i.e. transport sub-sector vs biofuel system?
- Are the results sensitive to changes in the modelling parameters for the C_{bio} sequestration (e.g. forest growth parameter, rotation length)?

Paper 2 (section 4.3):

- Does the chicken-egg dilemma, i.e. the timing of forest- C_{bio} sequestration with two opposed time perspectives (historic or future) affect the final results, and how?
- To which modelling approaches or system boundaries can the historic or future time perspectives be associated? How can the chicken-egg dilemma issue be solved?

The developed dynamic C_{bio} modelling framework for forest C_{bio} sequestration and the coupling with technical flows from the partial-equilibrium model for bioenergy (not restricted to this model outputs), is illustrated in Fig. 4-1. The scheme shows the parameters and data requirements, here referring to secondary data, yield tables, and national statistics; yet not excluding the use of primary data if available for case and/or site-specific studies.

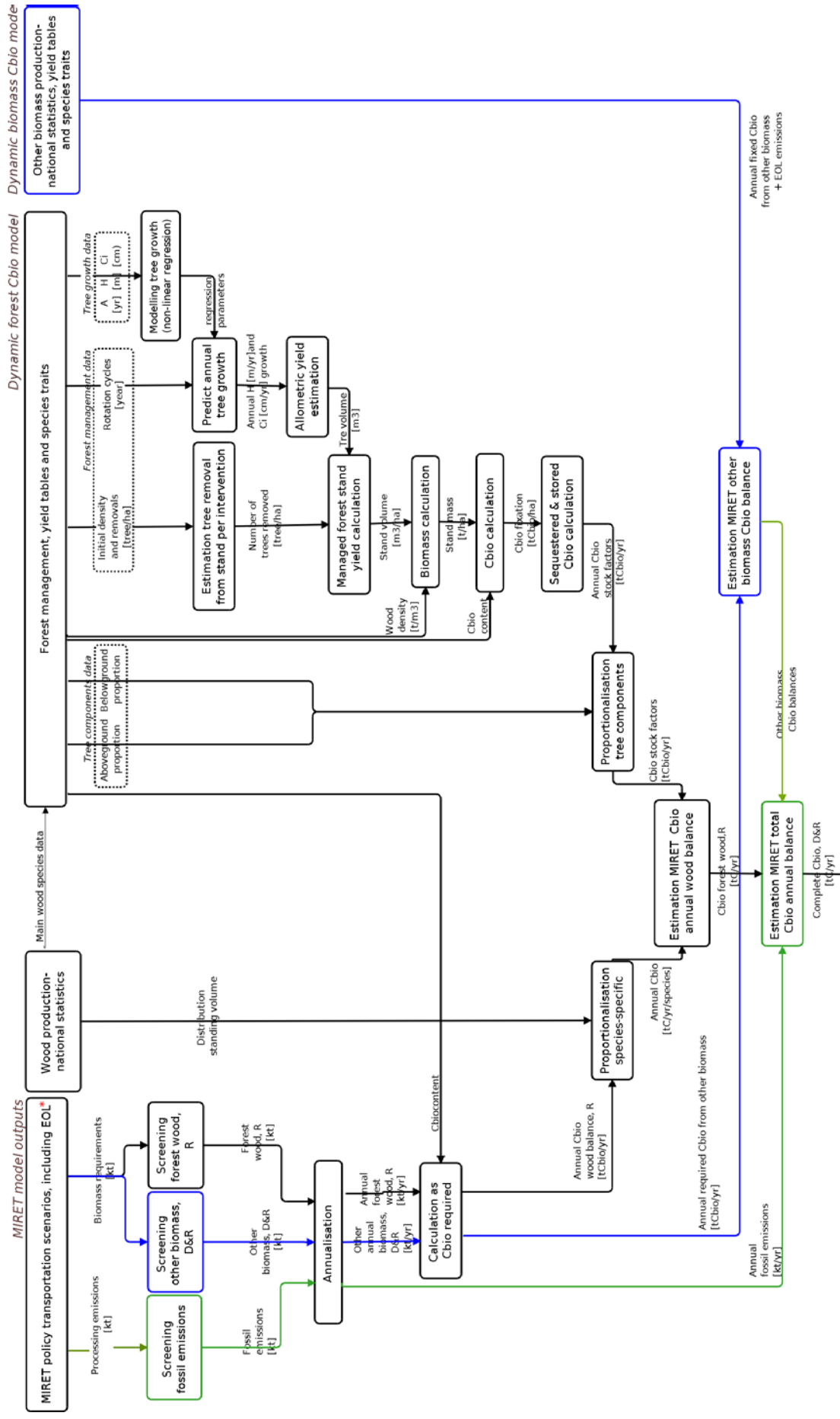

Fig. 4-1. Detailed modelling framework for dynamic biogenic carbon from forestry systems and coupling with demand models

An overview of the model technical and coupling specifications, building the basis of this work and the research articles, is shortly described, as follows:

1. Process demand model outputs (partial-equilibrium) by exporting forest wood commodity technical flows, annualising values with linear interpolation, and quantify carbon content of annual values
2. Modelling growth of time-dependent tree development per species using the Chapman-Richard model by means of non-linear regression analysis fitting growth parameters age (A) [year] to height (H) [m] and diameter breast height (DBH) [cm] and/or circumference (Ci) [cm].
3. Modelling biomass [$t\ ha^{-1}$] development based on allometric relations between growth variables (H and DBH/Ci) to stem and stand volume per unit of area [$m^3\ ha^{-1}$] and conversion to biomass through species-specific wood density properties [$t\ ha^{-1}$].
4. Modelling forest stand management by means of yield tables (data specified in Box 4-1).
5. Quantifying C_{bio} sequestration [$tC_{bio}\ ha^{-1}$] biogenic flows by means of species-specific or carbon partitioning among tree compartments.
6. Computation of C_{bio} derivative values to obtain dynamic biogenic carbon stocking factors [$tC_{bio}\ yr^{-1}$] per tree species or mean of all species.

Box 4-1. Data specification on yield tables

Yield tables tabulate the mean tree development and productivity dependent from age of fully stocked managed stands, and thus serve as guidance for potential forestry growth and yield modelling. The yield table data comprises the following data specifications for both the growth predictions and biomass yield estimations

- For growth development:
 - Age-height growth relation per species (meters per year increase)
 - Age-circumference growth relation per species (centimetres per year increase)
- For volume estimations from stem to stand:
 - Initial density of the forest stand (seedlings/ha)
 - Age of the thinning operations (year of cutting)
 - Rotation cycles of the thinning operations (frequency of each cutting period)
 - Total thinning interventions including final harvest (total number of cuttings)
 - Age of final intervention (clear-cut)

4.2 Paper 1: Model coupling in the context of forest bioenergy demand

This paper analyses dynamic C_{bio} flows of prospective consumption of forest wood residue commodity for advanced biofuels and proposes a coupling strategy with demand model (here partial-equilibrium model) to develop complete carbon balances; published in the Applied Energy journal (<https://doi.org/10.1016/j.apenergy.2019.01.186>), received 10 November 2018, revised 15 January 2019, accepted 21 January 2019, available online 2 February 2019].

Objective	Develop forest-related C_{bio} balances of energy-policy scenarios and emerging biofuel pathways, to: <ul style="list-style-type: none"> • Evaluate complete carbon balances (fossil + biogenic flows) • Compare with the static approach • Assess the model's sensitivity to C_{bio} parameters and rotation cycles
Approach	Coupling forest wood commodity outputs from partial-equilibrium model with dynamic forest C_{bio} model
Sector (product)	Transport (advanced biofuel)
Biomass	Forest wood residues
Supporting data	Data Paper in Appendix D: Data paper on forest models: C_{bio} growth and sequestration dynamic

Coupling partial-equilibrium and dynamic biogenic carbon models to assess future transport scenarios in France

Ariane Albers ^{a,b,c,*}, Pierre Collet ^a, Daphné Lorne ^a, Anthony Benoist ^{c,d}, Arnaud Hélias ^{b,c,e}

^a IFP Energies nouvelles, 1 et 4 Avenue de Bois-Préau, 92852 Reuil-Malmaison, France

^b LBE, Montpellier SupAgro, INRA, UNIV Montpellier, Narbonne, France

^c Elsa, Research group for Environmental Lifecycle and Sustainability Assessment, Montpellier, France

^d CIRAD - UPR BioWooEB, Avenue Agropolis, F-34398 Montpellier, France

^e Chair of Sustainable Engineering, Technische Universität Berlin, Berlin, Germany

* Corresponding author

Highlights

- Coupling economic and biogenic carbon models to assesses energy policy scenarios.
- Complete GHG life cycle inventories of the French transport sub-sector are built.
- Dynamic approach is needed for transport GHG emissions and impact determinations.
- The mitigation is 462% higher than the static assumption for 2G bioethanol.
- The model is sensitive to forest rotation length, robust to tree growth parameters.

Abstract

Bioenergy systems are promoted in an effort to mitigate climate change, and policies are defined accordingly to be implemented in the coming decades. Life Cycle Assessment (LCA) is used to assess the environmental performance of bioenergy systems, yet subject to the limitations of static approaches. In classical LCA, no temporal differentiation is undertaken: all inventoried instant to long-term greenhouse gases emissions (GHG) are aggregated and characterised in the same way, over a fixed time horizon, by means of fixed characterisation factors. Positive and negative impact contributions of dynamic biogenic carbon (C_{bio}) sum up to zero, yielding the same result as carbon neutral estimates. Climate mitigation results are biased without the temporal consideration of these flows. The purpose of the study is to highlight the time-sensitive potential climatic consequences of policy-driven transport strategies for metropolitan France, in the specific context of the dynamic LCA framework and climate change mitigation. We therefore propose a dynamic approach coupling a partial-equilibrium model (PEM) with dynamic C_{bio} models. The PEM analyses in detail the techno-economic performance of the metropolitan French energy-transport sector. It explores prospective optimisation options (supply-demand equilibrium) of emerging commodity and energy process pathways in response to a policy in question. The C_{bio} model generates dynamic inventories of the C_{bio} embedded in the primary renewable biomass outputs of the PEM. It captures the dynamic C_{bio} exchange flows between the atmosphere and the technosphere over time: negative emissions from fixation (sequestration) and positive emissions from release (e.g. combustion or decay). A dynamic impact method is applied to evaluate the mitigation effects of C_{bio} from forest wood residues by comparing the climate change impacts from complete carbon (fossil + biogenic) with carbon neutral inventories across scenarios. Two sets of results are computed concerning the overall transport (all emissions) and bioethanol (wood-to-fuel emissions) systems. The mitigation effect from long-term historic sequestration allocated to bioethanol (462%) is significantly larger than for transport (3%), expressed as the difference with carbon neutral estimates. The fossil-sourced emissions from bioethanol production represent only 5.4%. In contrast, a comparison with an alternative reference scenario involving wood decay demonstrated higher impacts (i.e. an increase of 316%) than carbon neutral estimates. The representation of the actual climatic consequences depends on the chosen fixed end-year of the dynamic impact assessment. Moreover, the mitigation effect is proven sensitive to the rotation length of forestry wood: the shorter the length the lower the mitigation from using renewable forest resources. Other energy-policy scenarios, C_{bio} modelling approaches and consequences of indirect effects should be further studied and contrasted.

Keywords: biogenic carbon, climate change mitigation, time-dynamic LCA, transport sector, partial-equilibrium model

Nomenclature

1G	First generation	GWP	Global warming potential
2G	Second generation	IPCC	International Panel on Climate Change
BAU	Business-as-usual	LCA	Life cycle assessment
C	Carbon	LGC	Lignocellulosic
C _{bio}	Biogenic carbon	LCI	Life cycle inventory
CF	Characterisation factor	LCIA	Life cycle impact assessment
CH ₄	Methane gas	MARKAL	Market Allocation
CLCA	Consequential life cycle assessment	N ₂ O	Nitrous oxide
CO ₂ -eq	Carbon dioxide equivalent	PEM	Partial-equilibrium model
EC-JRC	European Commission Joint Research Centre	RE	Renewable energy
FoWooR	Forest wood residues	TH	Time horizon
GHG	Greenhouse gases	TIMES	The Integrated Markal-Efom System

1. Introduction

The energy sector is the main contributor to global anthropogenic greenhouse gas (GHG) emissions [1]. In France, energy for transport is the principal emitter, accounting for almost one-third of the national emissions [2]. Policy planning faces the challenge of responding to climate change threats and secure future energy supply. Ambitious political targets enforce transitioning into renewable resources and increased energy efficiency, to limit temperature rise to 1.5 to 2 degrees Celsius [1]. The French Energy Transition for Green Growth Act), adopted in 2015, directs the energy sector towards low-carbon strategies and multi-annual energy programs [2]. France anticipates major renewable shares in the transport sector —aimed at mitigation of GHG emissions— gradually increasing up to the year 2050.

Energy modelling has become a key instrument to inform robust decision-making in energy system planning [3]. A wide variety of prospective models have emerged in the last half-century to support multilateral cooperation in macroeconomic energy system analysis. Top-down general-equilibrium models analyse the energy systems of a whole economy to identify cross-sectoral substitution alternatives [4]. In contrast, bottom-up partial-equilibrium models (PEM) analyse in detail the techno-economic performance of single energy sub-sectors [5,6]. Among the most used model generators featuring detailed technology databases are the MARKAL (MARKet ALlocation) and TIMES (The Integrated Markal-Efom System) of the International Energy Agency’s Energy Technology System Analysis Program [7–9]. More recently, hybrid models combine economy-wide perspectives with neoclassical growth models, sectoral and technological details [10,11]. Coupling with macroeconomic models at global scales, in the view of decarbonisation mechanisms to internationalise environmental externalities, is commonly discussed in climate change abatement efforts [8].

Biofuels are promoted as low carbon energy carriers to meet climate change and energy policy targets. However, these substitution alternatives have been questioned in the past. Environmental and social concerns have arisen from expanding food crop based biomass (e.g. corn, wheat, rapeseed),

particularly concerning land use and food security [12–16]. Dedicated or residual lignocellulosic biomass (e.g. forest wood, agricultural straw, miscanthus) are non-food alternatives to energy crops feeding a wide range of emerging energy pathways for heat, electricity or transport fuels. Techno-economic and environmental research has been conducted linked to bioenergy from innovative biomass supply chains, for instance, from forest wood residues [17–19], crop-residues [20–22], and miscanthus [23,24]. Advanced transport biofuels, from dedicated or residual lignocellulosic biomass, are under development to partially substitute petroleum fuels [25]. From 2020 onwards, it is expected that second generation (2G) biofuel pathways will generate cellulosic ethanol and Fischer-Tropsch biodiesel, at commercial scales, competitive with conventional fuels [26–28].

Life Cycle Assessment (LCA) is widely used to assess the climate change impacts and other potential environmental effects of bioenergy systems. Several bioenergy LCA studies have been carried out concerned with lignocellulosic biomass for electricity and heat generation, as reviewed by Muench and Guenther [29]. LCA has been increasingly combined with PEM in consequential LCA (CLCA) studies [30–38]. CLCA quantifies the environmental burden, and its variation, associated with changes in demand, often driven by policy decisions, beyond the boundaries of a particular production system [39]. It studies how flows change in response to a prior (retrospective) or future (prospective) decision [40]. The environmental consequences of a change in bioenergy systems are linked with expansion, displacement [41,42] or intensification [41,43]. Combined LCA and PEM has been applied to assess the prospective consequences of emerging markets (advanced commodity and bioenergy pathways), to estimate how future decisions would change material and energy flows. Menten and colleagues applied the French TIMES-MIRET model to improve consistency in prospective CLCA studies of biofuels and biomass-to-liquid processes [31]. Levasseur and colleagues used the Canadian TIMES NATEM model and complemented its outputs with LCA of alternative butanol from forest biomass pathways [30].

However, combined LCA and PEM approaches are usually static. The assessment of GHG emissions, for instance, focus on fossil fuels, while disregarding the time-sensitive climate change effects of biogenic carbon (C_{bio}) embedded in biofuels. C_{bio} refers to the carbon fixed in the biomass/plant resource through photosynthesis. The C_{bio} is temporally sequestered and stored in biomass and released back to the atmosphere at the end-of-life (e.g. through combustion or decay). The climate change impact category is based on the IPCC Global Warming Potential (GWP) metric [44]. The GWP method represents the weighted sum of all GHG emissions, such as carbon dioxide (CO_2), methane (CH_4) and nitrous oxide (N_2O), over a 20 or 100-year time horizon (TH), relative to the CO_2 reference gas, computed by means of characterisation factors (CFs). The GHG emissions are then expressed per functional unit of a product or service (e.g. per km driven by an average passenger car). This static method disregards the time dimension affecting climate change results [45–52]. In other words, GHG emissions are not differentiated through time.

The exclusion of dynamic C_{bio} elementary flows in the GHG inventories is justified by the carbon neutral hypothesis. This simplification based on the classical static approach, balances out the sequestration and release flows through the weighted sum of all emissions at time zero [53–55]. The bio-sourced GHG emissions, thus, yield zero climate change impact. However, this static methodological choice has been challenged for biomass resources with long rotation lengths, particularly from forestry [54,56,57]. Long CO_2 (re-)sequestration periods (e.g. forest trees) have time-sensitive effects, whereby rotation lengths lower than one-year (e.g. annual crops) may have small to zero impacts (equivalent to carbon neutral estimates) [58,59]. Long-term carbon stocks (e.g. forest trees) have a negative atmospheric impact, however they are reversible (i.e. reemitted) at some point in time, making it highly debatable whether or not assigning a value to it is justifiable [55,60,61]. Non consideration of long-term C_{bio} sequestration and the timing of this emissions release thus produce biased results [62].

In the last decade, new dynamic LCA approaches have emerged focused on time-sensitive climate change effects from bioenergy [47,49,51,63–65], and more specifically, linked to biogenic carbon accounting and forest resources [64,66–71]. Cherubini and colleagues proposed the biogenic global warming potential (GWP_{bio}) metric for bioenergy systems, using the impulse response function [72], to predict the biogenic CO_2 decay, as a function of biomass rotation dynamics [57]. The factors assign lower impacts to fast-growing vegetation and vice-versa. Yan developed CFs for different rotation lengths and harvest intensities based on forest-specific carbon cycle models [73]. The dynamic LCA method by Levasseur and colleagues enables assessing temporal emission profiles of fossil or biogenic flows, as a function of time [47]. The dynamic method computes time-dependent CFs for any year following an emission. Its application requires dynamic inventories, differentiating each emission flow from and to the atmosphere through time. Time-explicit C_{bio} inventories of forestry resources have been proposed by De Rosa and colleagues, through a simplified parametric model for aboveground and belowground forest carbon stocks [68]. To this day, no consensus exists on how to model dynamic C_{bio} inventories from renewable resources.

The purpose of this study is thus to assess, ex-ante, the time-sensitive potential climatic consequences of policy-driven transport strategies for France, by means of a full carbon accounting approach. We propose the coupling of a techno-economic and biogenic carbon models in the specific context of the dynamic LCA framework and climate change mitigation. The novel model coupling bridges the gap between research, development of emerging bioenergy systems and their actual mitigation effects.

2 Material and method

The proposed model-coupling of the PEM and the dynamic C_{bio} model is shown in Fig. 1. The overall coupling strategy is as follows: The renewable commodity forest wood residues (hereafter referred as FoWooR), described by the PEM, is selected for the first coupling attempt. The dynamic biogenic

carbon is assessed through a C_{bio} modelling tool developed for this coupling strategy. It models the dynamic C_{bio} exchange between the atmosphere and the technosphere over time: negative emissions from fixation (sequestration) and positive emissions from release (e.g. combustion or decay). The model generates dynamic inventories of the C_{bio} embedded in the renewable FoWooR biomass (hereafter referred to as C_{bio} balance. For the climate change impact assessment, a dynamic method is applied to compare the climatic consequences of carbon neutral (without C_{bio} : hereafter referred to as “C neutral”) and complete carbon balances (with C_{bio} : hereafter referred to as “complete C”) in response to policy scenarios. The complete C balance is built upon both fossil and biogenic material and energy flows from production and consumption of petroleum fuels and biofuels, while the C neutral approach accounts for the fossil ones only. The coupled model thus produces a dynamic climate change impact assessment of prospective renewable biomass and energy pathways driven by and representing policy decisions. All sections, following the classical LCA steps: goal and scope, life cycle inventories (LCI), and life cycle impact assessment (LCIA).

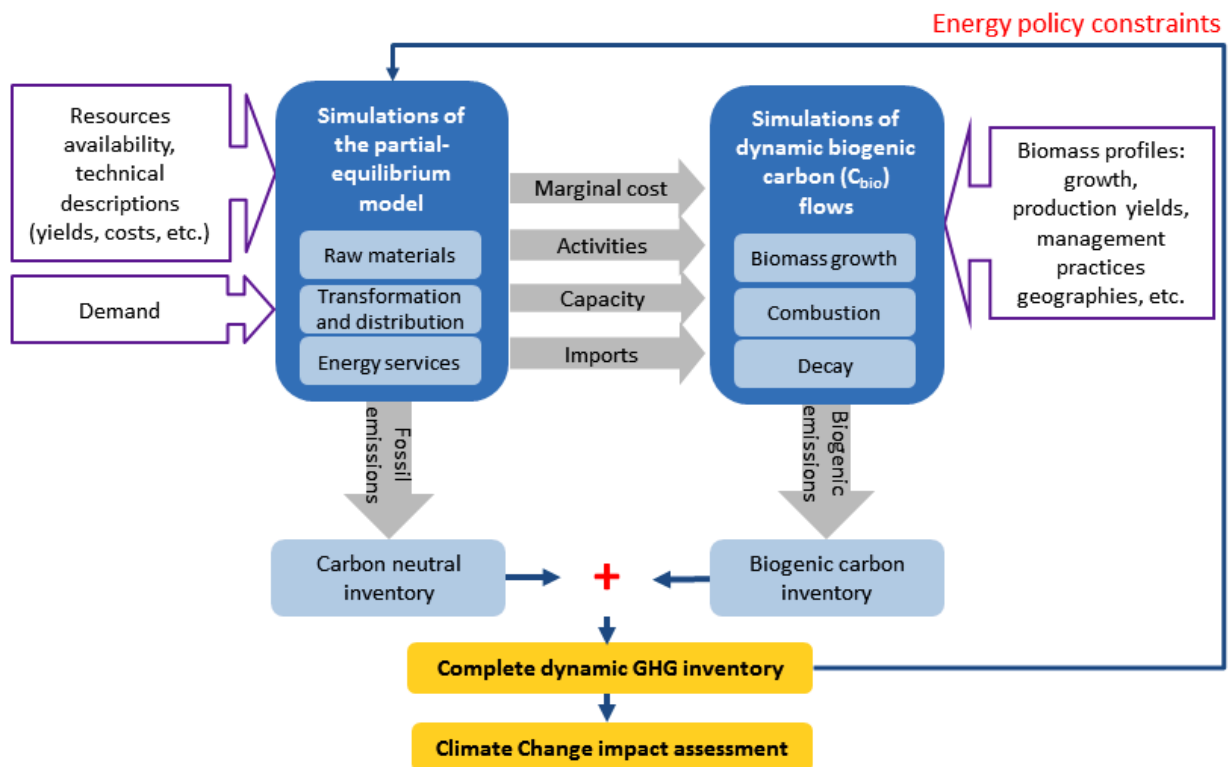

Fig. 1. Conceptual diagram of the model coupling strategy of the TIMES-MIRET partial-equilibrium model with dynamic biogenic carbon modelling

2.1. Goal and scope: temporal boundaries

The goal of the present study is to highlight the time-sensitive potential climatic consequences of policy-driven transport strategies for France. The system boundary is the transport sub-sector, with special focus on 2G biofuels. Energy services from electricity and heat for other end-users (e.g.

industrial, domestic) are excluded from the study. The C_{bio} balance represents the supply of FoWooR, as a primary renewable resource for biofuel production. The LCIA is based on time-dependent CFs [47] and is expressed here in mega-tonnes of carbon dioxide equivalent. Other LCA environmental impact categories are outside the scope of the study, as the main focus is the time sensitive climate change impact assessment of dynamic C_{bio} flows and its comparison with C neutral approaches.

The dynamic LCA approach, aims at developing a dynamic complete C balance (fossil + biogenic emissions). Therefore, the temporal differentiation of all emission flows, particularly of biogenic origin, is a fundamental precondition. The temporal system boundary requires all necessary time specifications of the entire study under assessment, namely the time step as well as both the LCI time horizon (LCI TH) and the LCIA time horizon (LCIA TH), specified below.

The time step defines the temporal frequencies over which the emissions are inventoried and assessed (e.g. per minute, hour, day or year). It is set by the inherent time scales of the impact categories [74,75]. Inherent features of impact categories (e.g. climate change, acidification, eutrophication, etc.) relate to several biogeochemical processes, defining the temporal resolution at which dynamic inventories can be modelled. LCA methods encompass different impact categories; however, the present study is only concerned with climate change category. For this impact category, the time scale of the flows is recommended at annual frequencies [48,76]. Therefore, the dynamic computation of the technical flows and elementary flows are modelled on an annual basis.

The LCI TH defines the timeline over which the GHG emissions are considered in the study, describing each emission flow through time. We perform a full-time inventory of all GHG emission with no temporal cut-offs. Since the model-coupling in this study aims at assessing the PEM outputs, the negative and positive flows are aligned with the TH of the PEM simulation. TIMES-MIRET runs over multiple-periods (3 to 5 years) until the year 2050. For this study the PEM outputs from 2019 to 2050 are taken into consideration. A linear-interpolation is performed to track the multi-period outputs on an annual basis and develop annual values for the dynamic inventories. The LCI TH of all negative emission flows is defined by the chosen modelling approach taking into account historic or future C_{bio} fixation time perspectives (described in section 2.3.1).

We inventoried the C_{bio} sequestration flows before the final harvest of FoWooR (historic perspective). A full rotation length accounts for 200 years in this study. The long-sequestration period follows the C_{bio} model [77], as detailed in section 2.3.1. It represents all main tree species of the French wood industry, with Sessile Oak (*Quercus petraea*) having the longest sequestration length. For the historic C_{bio} computation, the TH of the PEM simulation represents the last year of the C_{bio} fixation, at which final harvest of FoWooR occurs. For instance, for the period 2019-2050, the first fixation flow starts 200 years in the past (year 1819) for the year 2019, 1820 for the year 2020 and so forth until 1850 for the last simulation year (2050).

The LCIA TH, likewise, defines the period over which the climate change impact is considered by means of setting a fixed reference year or an end-year of the impact assessment. The commonly used TH for the climate change characterisation in LCA is one century, as per the default GWP metric [45,78,79]. We therefore fix a future reference year to 2119, 100-years after the first PEM simulation year (2019). Yet, any end-year or TH can be chosen when dynamic LCIA is performed with time-dependent CFs.

Finally, the temporal system boundary for the entire study under assessment can be described. The annual time step consideration of a full-time accounting approach with historic fixation flows and a fixed future reference year, sets the overall temporal system boundary over the period 1819 to 2119: 300 years in total. This temporal specification provides transparency and allows a systematic comparison among all assessed PEM policy scenarios. Moreover, the selected period represents consistency between the LCI and the LCIA TH, with no temporal cut-offs. Accordingly, we ensure that all inventory flows are projected over the same TH into the future.

2.2. Life cycle inventories: partial-equilibrium model outputs

2.2.1. Description of the key elements

The economic partial-equilibrium model used in this study is the TIMES-MIRET, adapted to the modelling framework from the MARKAL/TIMES family of models [7–9]. TIMES-MIRET analyses the energy-transport system of metropolitan France over a multiple-period horizon based on prospective demographic and economic projections [79]. The model conducts a detailed bottom-up techno-economic analysis, describing the primary resource supply (petroleum fuels and biomass), its transformation to secondary fuels via different process pathways (refinery), and the final energy consumption (electricity, heat and transport fuels) [8]. Petroleum- and biomass-based commodities represent the supply of energy sources to meet the future energy demand. Each source has an attribute, detailing the availability/import, capacity and marginal cost. The demand curve is represented by the energy services in transportation (automobiles, trucks, rail, and aviation), domestic and commercial (space heating, lightning, cooling), industry (chemicals, steel) and agriculture segments [9]. In TIMES-MIRET the assessed useful energy includes electricity and heat (hereafter referred to as “energy mix”), and transport fuels (hereafter referred to as “transport sub-sector”). The output from the supply-demand equilibrium assumes a perfectly competitive market, in which producers and consumers maximise their net total surplus or minimise their net total costs, while meeting several (policy) constraints [5,9].

The TIMES-MIRET PEM scenario simulations disregard cross-sectoral interactions within a whole economy (in contrast to general-equilibrium models). However, each scenario explores the linear programming optimisation of supply-demand in detail based on a technology-explicit database linked

with different commodities. For instance, for the transport sub-sector the functional unit of the sectoral output is the kilometres travelled by a specific transportation means (e.g. average passenger car, heavy trucks, etc.). In bottom-up PEM models, the existing and future technologies to produce that given unit are explicitly specified [9].

2.2.2. Definition of policy scenarios

TIMES-MIRET outputs are scenario-dependent. The assessed policy scenarios are compared with a reference policy scenario (business-as-usual, BAU). The BAU scenario represents a baseline against which alternative policy scenarios are compared. BAU is formulated from historical and established norms considered valid until the end of the PEM simulation TH. The reference policy draws back to the 2009 EU Directive and National Renewable Energy Action Plan, pursuing renewable energy targets in the gross final energy consumption by the year 2020. Therefore, the initial period of the TIMES-MIRET is calibrated to the year 2009, fixing the historic values and main variables, yet considering changes in future demand.

The alternative policy scenario assessed in the present study is named 15Bio. It corresponds to the national long-term, multiannual energy transition plan, partly formulated from the French Energy Transition for Green Growth Act. For the 15Bio scenario, we adopted the 15% RE share in the transport sub-sector by 2030, in reference to the year 2012. This specific target for the transport sector was subjected to the EU Renewable Energy Directive legally binding Member States to increase the RE share in addition to limiting food crop-based biofuels (first generation, 1G) to 7% by 2020. For the French national energy plan, this target remains effective up to the year 2030. Hence, the 15Bio scenario involves all constraints of the BAU reference, including the new set of policies (i.e. limiting 1G biofuel share to 7% and increasing the renewable energy share by 15% by 2030). A comparison with the BAU scenario, allow identifying the policy-induced consequences of energy-transport pathways in response to fossil fuel and energy-crop substitution targets to mitigate climate change.

2.2.3. Selection of the model outputs

In the LCA context, the PEM commodities represent the technical flows, while all life cycle carbon and GHG emissions the elementary flows. For the model coupling, the technical and elementary flows of the PEM are exported per BAU and 15Bio policy scenarios. All flows associated with the transport sub-sector are separated from the pathways for other end-users. For instance, cogeneration processes (heat and electricity generation) and biochemical or thermo-chemical processes (bioethanol production) are both linked to FoWooR commodity in the 15Bio scenario. For the present study, we exclusively focus on the pathways associated with transport fuels only.

Concerning the technical flows for modelling C_{bio} inventories, the selection of the biomass commodity followed two main criteria: lifespan of the vegetation with a full rotation length longer than one year

and contribution to 2G transport biofuels. FoWooR is an energy carrier with mid- to long-term sequestration periods, and under the new set of policies, it is expected to contribute to 2G bioethanol with mayor shares. Annual crops are excluded from the C_{bio} modelling, as their C_{bio} fixation-release dynamics occur within one year (equivalent to carbon neutral approaches), thus no climate change impact is estimated. Other long-lived renewable biomass resources, such as short-rotation coppices or perennial crops, could have been modelled to include their C_{bio} balances in the dynamic GHG inventories. However, their contribution to 2G biofuels is comparatively small or absent in the 15Bio scenario, and thus negligible for the C_{bio} analysis under the assessed 15Bio policy scenario.

The PEM input data for FoWooR in the 15Bio policy scenario is based on national forest inventories for the French wood supply chain and a roadmap 2035 study made about the future availability of this renewable resource in France [78]. The prospective assumptions consider, among others, harvest losses amounting 8% for merchantable wood, 15% for merchantable and residues and 50% when FoWooR are harvest separately [78].

Regarding elementary flows for modelling carbon neutral GHG inventories, fossil-based CO_2 and N_2O elementary flows are provided by the PEM associated with all production and consumption pathways: biomass cultivation, transportation, (bio-)refinery, industry, tailpipe, and trade. However, all elementary flows of the transport-pathways are re-calculated, using the updated emission factors of the European Commission Joint Research Centre (EC-JRC) based on the JEC Well-To-Wheels (WTW) method [80]. The emission factors are expressed in equivalent CO_2 emissions per MJ petroleum- or biomass-sourced fuels. To recalculate the CO_2 -equivalent values into the respective GHG elementary flows, the values are divided by the IPCC GWP equivalent factors [44]. The proportions of the CO_2 , N_2O and CH_4 GHG emission per specific fuel are also taken from the EC-JRC [80]. The fossil-sourced elementary flows from the transport sub-sector are combined with the biogenic-sourced flows to develop a complete C balance and compare its climate change impact with C neutral approaches.

2.3. Life cycle inventories: biogenic carbon model outputs

The technical flow (i.e. the FoWooR commodity) is coupled with the C_{bio} models to compute time-explicit C_{bio} inventories. The mass of FoWooR is expressed in C_{bio} by means of a wood-specific carbon content factors (0.4952) denoting the weighted mean of all assessed forest tree species of the French wood supply chain [77]. The C_{bio} elementary flows represent the C_{bio} embedded in the primary FoWooR supply flows per tonne of FoWooR [$t C_{bio}$]. The coupling with dynamic C_{bio} models further generates annual fixation and release flows. The dynamic C_{bio} balance is converted into biogenic CO_2 and CH_4 for the impact characterisation by multiplying the molecular weight of CO_2 or CH_4 to the atomic substance of C (44/12) or (16/12) respectively. CH_4 is considered for decay estimates only [81–83].

For the C_{bio} balance, the belowground tree compartment (roots and stump) is also considered, to include both aboveground and belowground C_{bio} dynamic. This implies allocating a proportion of belowground biomass to the FoWooR. The aboveground compartment represents about 80% of the tree (63% stem and 37% FoWooR). 20% of the tree consists of belowground biomass, as computed with our C_{bio} modelling tool. The values are congruent with other studies (e.g. [84]). The allocation factor for the belowground biomass corresponding to FoWooR was estimated at 0.25 of FoWooR, which represents 7.4% of the total tree biomass.

2.3.1. Computation of carbon fixation from forestry resources

Fixation represents the withdrawal of CO_2 from the atmosphere due to photosynthesis. The dynamic C_{bio} modelling of the FoWooR applied dynamic growth models from forestry science, elaborated for the French forest wood industry. The modelled data supports and informs dynamic modelling approaches to predict mean growth and C_{bio} fixation dynamics of a tree or forest stand over a given rotation length. All data and modelling steps for the C_{bio} fixation flows were obtained from yield tables per unit area of forest stands, non-linear growth models and allometric relations (see Table 2 in [77]). The tabulated yield table data based on empirical evidence originated from long-standing experimental forest plot surveys of managed forests throughout France [85] or other regions when not available for France [86,87]. The non-linear growth curve is represented by the often used Chapman-Richards (CR) model, a sigmoid and asymptotic curve [88–90]. The CR equation (Eq. 1) expresses the potential growth ω of a tree species i in height and diameter-breast-height or circumference (response growth variables) at age t (independent variable), with species- and site-dependent parameters A, β, k, p [91]:

$$\omega(t_i) = A(1 - \beta \exp^{-kt})^p + \varepsilon \quad (1)$$

with $p = 1/(1 - m)$

For the C_{bio} fixation dynamics, we used annual stocking values from all assessed tree species (Table 2 in [77]) and the weighted mean based on the standing wood production volumes and distribution from national statistics and surveys [92] (see Table 3, 5 and 6 in [77]). The annual stocking factors are expressed in tonnes of C_{bio} . Note that the dynamic C_{bio} fixation model represents monospecific (individual-species) uneven-aged forest stands with homogenous growth. Other site-dependent dynamic elements related with, for instance, mixed forest stands (two or more species per forest stand), and losses from mortalities, including those unexpected due to natural events (e.g. wildfires, diseases, winds) and soil organic carbon, were not modelled. For modelling site or case-specific fixation dynamic, these site-specific parameters would further complement and improve dynamic approaches.

For the computation of C_{bio} fixation, two time-dependent accounting approaches can be followed for the first C_{bio} fixation flow: a) a full rotation length starting after the wood-use, in the same year of final wood harvest, when trees are removed from the forest stand and new seedlings are re-planted; or b) a full rotation length starting before the wood use. The former refers to C_{bio} fixation flows with future timelines and the latter to historic ones. In previous LCA studies, future [68,93], historic [94–96], and both [67,97], C_{bio} fixation time perspectives were tested. In the present study, we computed C_{bio} fixation flows with historic timelines. The reasoning behind this modelling approach is based on the assumption that the provision of FoWooR as biofuel feedstock is retained from sustainably managed forests in the French/EU context. According to Lindeijer and colleagues, the origin of the biotic resource defines whether the modelled systems is man-made controlled or a natural ecosystem [98].

The biogenic carbon fixation dynamic [t C_{bio} .y-1] is defined by:

$$\frac{dc}{d\tau} = f(p, \tau) \quad (2)$$

$$\int_{\tau_0}^{\theta} f(p, \tau) \cdot d\tau = c_b(\theta) = 1 \quad (3)$$

where c_b the relative biogenic carbon fixation expressed in tonnes, $f(p, \tau)$ is the carbon fixation model with a set of parameters of the Chapman-Richards model (p), τ (y) is the time variation between the start time (τ_0) of the biogenic carbon fixation and the cutting time (θ) defined by each thinning and a final cut time (i.e. harvest at the end of the rotation length).

The coupling with the partial-equilibrium model is carried out following Eq. 4 and Eq. 5, where C is the total biogenic carbon, $E_{(t^*)}$ is the biogenic carbon output from the partial-equilibrium model, expressed in tonnes, at a given time t^* . The fixation dynamic at t^* is computed following the computation in Eq. 6:

$$\frac{dC}{dt} = \frac{dc}{d\tau} E_{t^*} \quad (4)$$

with t the a time of the MIRET scenario and

$$C(t^*) = c(\theta) E_{t^*} \quad (5)$$

Thus,

$$\tau = \theta - (t^* - t) \quad (6)$$

$$d\tau = dt$$

$$\frac{dc}{d\tau} = f(p, \theta - t^* + t)$$

$$\frac{dC}{dt} = f(p, \theta - t^* + t) E_{t^*}$$

2.3.2. Computation of carbon release from forestry products

The C_{bio} release to the atmosphere is positive, because it contributes to the atmospheric GHG concentration and thus to the radiative forcing effect. The flow occurs when the C_{bio} is emitted back at the EOL of the biomass product. For bioenergy systems, the EOL is the combustion process. EOL combustion of bioenergy is linked with internal combustion engines (transport tailpipe) or cogeneration processes (energy mix). In the present study, it is assumed that the biomass is harvested, processed and used within the same year. This means that the total embedded C_{bio} in the FoWooR, including co-products and wastes, is emitted back to the atmosphere within the same year of harvest.

However, when the residual part from logging operation are not used for the bioenergy market (e.g. 2G bioethanol), they are left in the forest. The alternative EOL pathway corresponds to a reference scenario in which FoWooR are left behind and excluded from economic activities. For comparison purposes, the selection of an adequate reference system was already highlighted by other authors [99,100]. For the alternative EOL pathway, the left behind FoWooR are subjected to onsite natural decay processes by microbes in the soil in forest ecosystems. After harvest aboveground residues and belowground biomass are assumed to decay completely over time [101]. Emissions due to decay occur over long periods of time, gradually decreasing towards zero. The decay curve of residual dead wood biomass can be estimated via a first-order exponential decay equation (Eq. 7), where M_t is the remaining mass at time t , M_0 the initial dry mass, and τ is the half-life estimates.

$$M_{(t)} = M_0 \times e^{-t/\tau} \quad (7)$$

The negative exponential decay model is commonly used and recommended to estimate forest wood degradation [19,21,102,103]. Half-life values for decay vary depending on the tree compartment. For τ we used eight years for coarse woody debris and thirty years for dead stumps and roots [104]. A part of the embedded C_{bio} in FoWooR is emitted as CH_4 (due to anaerobic degradation), ranging between 0% and 3% (we used 1.5%) for coarse woody debris (branches, twigs and foliage) and 10% for belowground dead stumps and roots [105]. The CH_4 releases are very uncertain and site-dependent. CH_4 ratios for belowground degradation are not easily available, thus we used 10% as a proxy from mulched wood and following a root-shoot rational [101].

2.4. Life cycle impact assessment: dynamic climate change

For the dynamic LCIA of the climate change characterisation, time-dependent CFs proposed by Levasseur and colleagues were applied [47]. The time-dependent CFs assess the annual GHG emission profiles from fossil or biogenic sources as a function of time. The method is based on the radiative

forcing (RF) concept, similar to the IPCC default GWP metric [44]. However, the assessment is based on instantaneous RF values with no fixed TH. The CFs have variable THs, as they assess the impact of GHG emissions for any year following the emission at the year of its release to the atmosphere. This dynamic method, thus, allows assessing different THs generated by different emission years [47].

The cumulative annual values of the RF are expressed in watts year per square meter [$W \cdot yr \cdot m^{-2}$]. The values can further be expressed in equivalent CO_2 climate change impact per unit mass assessed. The dynamic characterisation, yet implies a “fixed future reference time” [106], meaning that even though the TH is variable, a reference TH is required. Thus, the dynamic climate change impact expresses the effects between the GHG year (i.e. the time when emissions is released to the atmosphere) and the chosen fixed reference year [107]. In a classic LCA approach, no temporal differentiation is undertaken at both the LCI and LCIA phases: all inventoried GHG emissions are aggregated and characterised in the same way. Positive and negative impact contributions of biogenic emissions sum up to zero, yielding the same result as C neutral estimates. For static climate change impact via the default IPCC GWP thus yield zero for biogenic flows. Many LCA studies use this static approach analogously to climate neutral [108], to express a zero climatic effect from bioenergy systems. However, in recent years, this approach has been questioned and criticised [59,109], as a pulse emission of a given substance into the atmosphere has an effect on the atmospheric concentration and thus on the radiative forcing, regardless whether it originates from biogenic or fossil fuel sources.

2.5. Summary of all steps for the model coupling and computation

A summary of the described model-coupling steps is shown in Fig. 2. Each technical and elementary flow of the PEM (detailed in section 2.2.3) is treated separately. The annual biomass technical flows per PEM scenario are transformed into C_{bio} elementary flows according to biomass-specific carbon content values (see section 2.3.1). The annual C_{bio} elementary flows are computed with the dynamic C_{bio} models to capture the dynamic of C_{bio} fixation flows from the atmosphere [$t C_{bio} \cdot yr^{-1}$] (detailed in section 2.3.1), and the C_{bio} release flows to the atmosphere (detailed in section 2.3.2). The annual C_{bio} release factors are specific to the EOL option chosen (e.g. combustion for bioenergy, decay for left-behind biomass). The time-explicit computation of the fixation and release flows forms a dynamic C_{bio} balance [$t \cdot yr^{-1}$]. The C_{bio} balance is subsequently transformed into the corresponding biogenic GHG emissions (here CO_2 and CH_4). The fossil source GHG emissions (here fossil CO_2 , CH_4 and N_2O), corresponding to the C neutral approach, are included in the assessment. For a full-time accounting with no temporal cut-offs, all GHG emissions are inventoried over the respective LCI TH. For the LCIA characterisation, all dynamic inventories are computed with time-dependent CFs (detailed in section 2.4). The variable future fixed reference year, and therefore the LCIA TH, is set by the user. Subsequently, the impact results from a complete C balance (fossil + biogenic) are compared with the C neutral (fossil) flows per policy scenario.

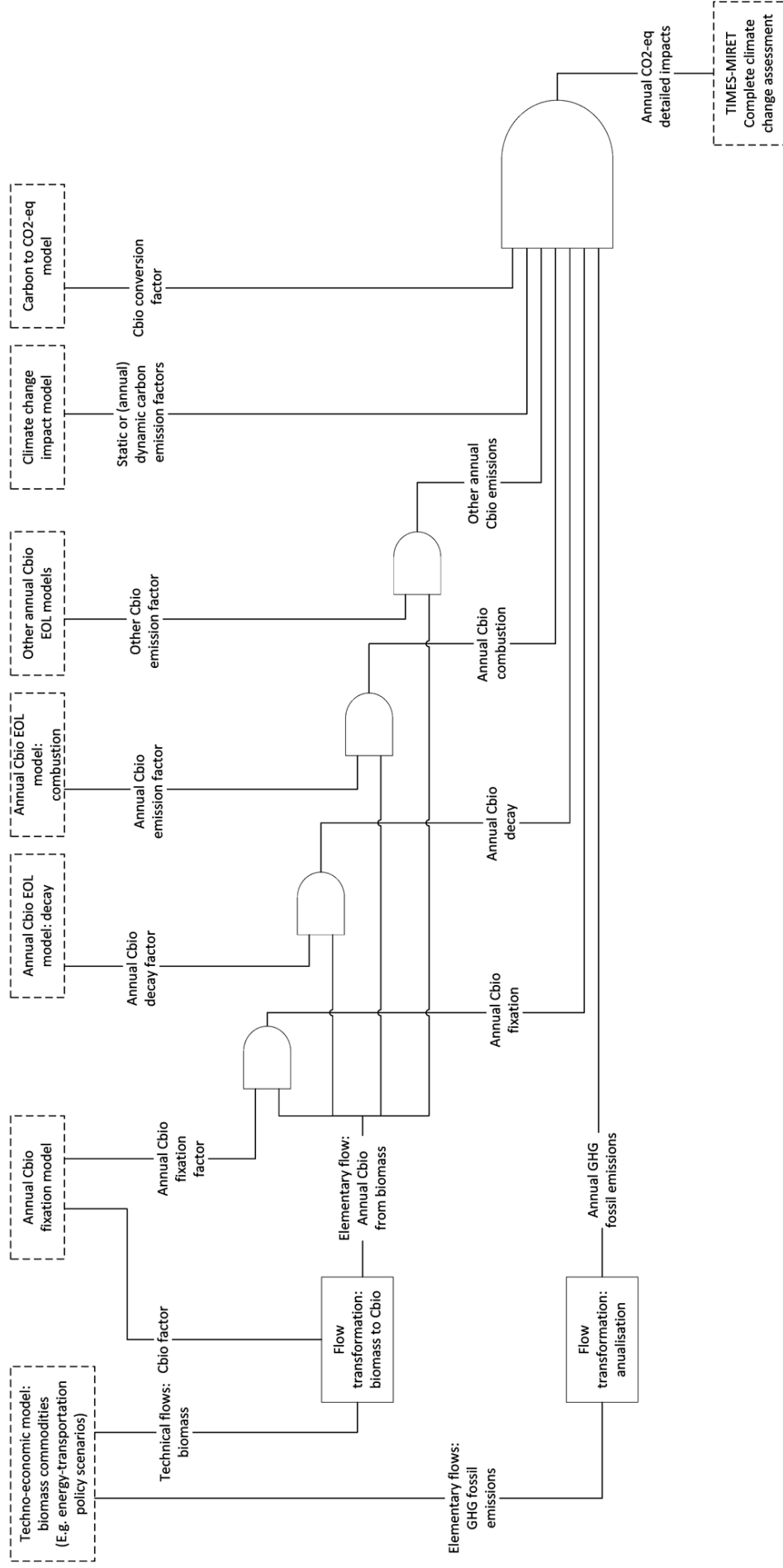

Fig. 2. Diagram for coupling TIMES-MIRET partial-equilibrium model with dynamic biogenic carbon models

3. Results and discussion

The results of applying the coupled model are presented in this section, for both the dynamic LCI and LCIA of the BAU and 15Bio scenarios. The dynamic inventories, based on the TIMES-MIRET PEM outputs, were constructed around the primary biomass supply for all end-users, as well as the mobilisation of renewable commodities and the final energy consumption (petroleum fuels and biofuels) to the transport sub-sector. The dynamic inventories for the C_{bio} balance demonstrate all sequestration and release flows from the FoWooR transport pathway. Additionally, all dynamic inventories of transport were plotted in a Sankey-style diagram specific to the year 2030. For the dynamic impact assessment two systems were computed: i) the transport sub-sector in terms of GHG emissions from all transport pathways, and ii) bioethanol, encompassing GHG emissions from the FoWooR-to-bioethanol pathway only. The results per system and scenario were compared under two distinctive accounting approaches, corresponding to the relative climate change impact based on the C neutral (fossil-only) and complete C (fossil + biogenic) inventories. This comparison strategy is used to identify whether the inclusion of the C_{bio} dynamic, represented with the complete C inventories, leads to climate mitigation effects compared to C neutral estimates. Additionally, the impact of a hypothetical reference system (BAU* scenario) featuring an alternative EOL decay pathway for FoWooR was computed and compared with the EOL combustion pathway. Finally, a sensitivity analysis was carried out to assess the robustness of the applied C_{bio} model as well as the sensitivity of the mitigation results with respect to the chosen rotation/sequestration length.

3.1. Dynamic inventory results

3.1.1. Partial-equilibrium model biomass outputs and energy pathways

Fig. 3 shows the primary biomass supply outputs [in Mt], from the PEM, of the BAU and 15Bio scenarios from 2019 to 2050, whereby Fig. 3a relates to energy mix + transport and Fig. 3b to the transport sub-sector. The biomass commodities described in the PEM were dedicated energy crops (corn, triticale, wheat, sugar beet, rapeseed, sunflower, palm oil, soybean), dedicated lignocellulosic material (LGC: miscanthus and other perennial crops), and residual biomass (FoWooR, from forestry and agriculture). The commodity category “energy crops” includes renewable resources associated with first generation (1G) biofuels, while dedicated LGC material and residual biomass associate with 2G biofuels. All described commodity were first exported from the PEM, as shown in Fig. 3a, to identify the pathways linked to transport end-users. The commodity with the largest primary biomass share of the biomass supply was FoWooR, with proportions of up to 68% and 71% for BAU and 15Bio respectively. Annual mean values for FoWooR were estimated at 32 Mt for BAU and 34 Mt for 15Bio. The new set of policy constraints did not significantly change the FoWooR outputs over the PEM simulation TH, as compared with BAU. However, LGC material was introduced as a new commodity in the 15Bio scenario.

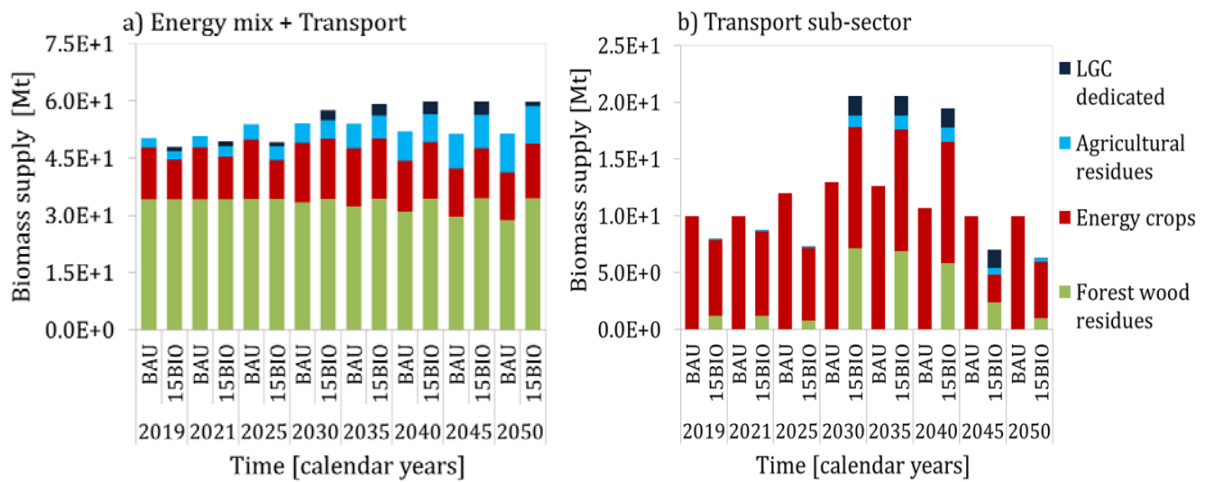

Fig. 3. TIMES-MIRET primary biomass supply from 2019 to 2050 per BAU and 15Bio scenarios of a) Energy mix (heat and electricity) and transport, and b) Transport sub-sector only

An in-depth assessment of the transport sub-sector pathways, demonstrated a shift of the biomass commodities from the energy mix + transport to the transport sub-sector between BAU and 15Bio. FoWooR and agricultural residues, as well as LGC material, were mobilised for transport fuel processes, as shown in Fig. 3b. The LGC material commodity was introduced to feed the transport sub-sector, as compared with all commodities in the energy mix + transport PEM outputs (Fig. 3b). A comparison among the scenarios, demonstrated that under BAU conditions, transport biofuels would exclusively be produced from energy-crops. 1G biofuels would remain the only substitute to petroleum fuel. The other biomass commodity pathways in BAU would feed the energy mix (i.e. electricity heat cogeneration processes for other end-users) only. In the 15Bio scenario, the mobilisation of FoWooR supply to transport was linked to the production of cellulosic bioethanol. It represented the only feedstock for 2G bioethanol. Peak 2G bioethanol production values were estimated in the year 2030, amounting up to 21 Mt (35% of the total biomass share for transport).

Fig. 4 shows the final energy consumption share [in MJ] of the transport sub-sector, per scenario, from 2019 to 2050. The depicted energy carriers represent the end-user energy demand by a wide range of transport means. The prospective supply is based on the number of kilometres travelled per transport means. It is expected that the final energy share will slightly decrease under the given assumptions, as more passengers would travel per trip of all transport means. The bioethanol energy carrier includes both 1G and 2G biofuels, whereas FoWooR represented the main feedstock for 2G cellulosic bioethanol production (in the 15Bio-transport scenario). Other potential biofuel pathways and process outputs, such as Fisher-Tropsch biodiesel, were not simulated under the new set of policies. In contrast, under BAU constraints, only 1G bioethanol from energy crops would be produced.

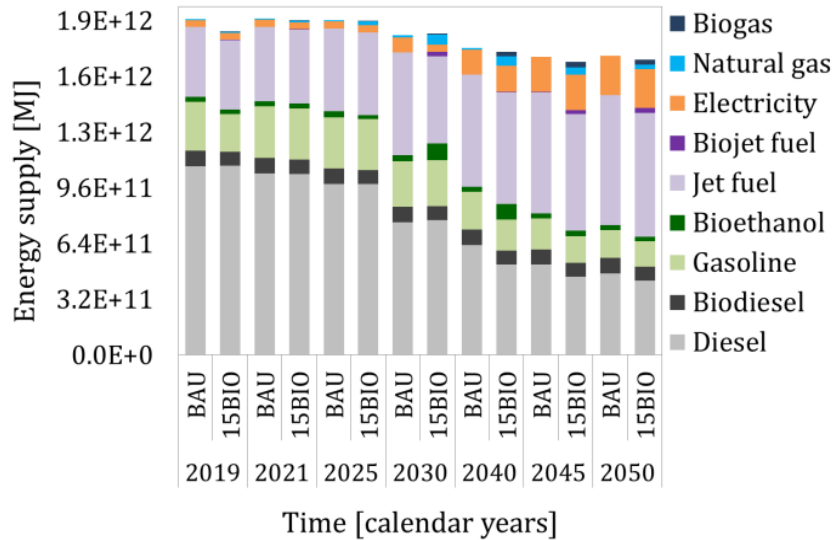

Fig. 4. Final energy consumption in the transport sub-sector per energy carrier and per scenario

The new commodity and energy pathways in the transport sub-sector were created in response to the new policy constraints (15Bio scenario). Compared with the BAU reference, the energy-market dynamics changed in response to the policy constraint by optimising the outputs to secure energy supply by cost-effective means. These outputs are supposed to partially substitute 1G biofuels and petroleum fuels. Yet, the overall share of FoWooR, and thus that of 2G bioethanol to the transport sub-sector, remained less significant than the share of energy crops for 1G biofuels, up to the year 2050.

3.1.2. Biogenic carbon balance from forest wood residues

Fig. 5 shows the C_{bio} balance results of FoWooR for the transport sub-sector, under both BAU and 15Bio scenarios, expressed in Mt C_{bio} . The C_{bio} flows for the BAU reference were zero, as no FoWooR were accounted for the transport pathway (Fig. 5a). The flows from the historic C_{bio} fixation were inventoried as negative (sequestration) and the C_{bio} combustion as positive (release back to the atmosphere). A full-time accounting with no temporal cut-offs, allowed differentiating all C_{bio} flows of fixation and release through time. The LCI TH was defined as the 1819 to 2050 period. The PEM simulation TH (2019 to 2050) represented the years of final harvest (final fixation flow) and the years of production and consumption of FoWooR-based 2G bioethanol (release flows). The first C_{bio} fixation flow started in the year 1819, due to the application of a historic full-rotation length of 200 years (see section 2.3.1). From the year 1819 onwards, the C_{bio} fixation values were accumulated until the final harvest in the year 2019. This has been repeated for each following simulation year until 2050, which is the end year of the C_{bio} balance for both negative and positive emission flows.

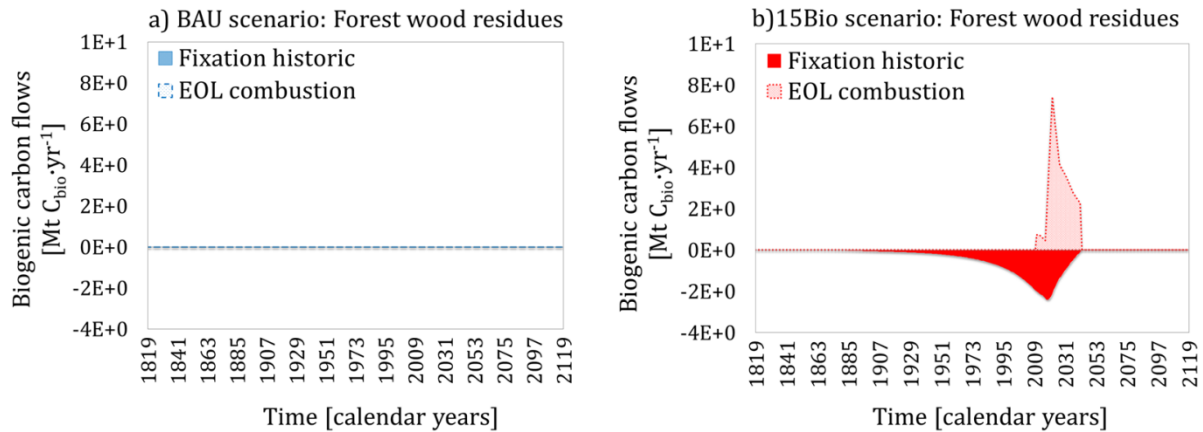

Fig. 5. Dynamic biogenic carbon (C_{bio}) balance of residual forest wood biomass [$\text{Mt } C_{\text{bio}} \cdot \text{yr}^{-1}$] in the transport sub-sector with historic fixation (positive) and EOL combustion (negative) flows of a) BAU scenario, and b) 15Bio scenario

Under the assumption of combustion as EOL, the total C_{bio} fixation ($-1.01\text{E}8 \text{ Mt } C_{\text{bio}}$) and release ($+1.01\text{E}8 \text{ Mt } C_{\text{bio}}$) flows sum up to zero, with no temporal cut-offs. The area below the curve is equal for both flows, meaning that the total C_{bio} embedded in the FoWooR is emitted back to the atmosphere during 2019 and 2050. This confirms that 100% of fixed C_{bio} is released back, as presumed under the carbon neutral hypothesis. Yet, the annual biogenic values are not carbon neutral and, therefore, not zero. The time-explicit differentiation of the C_{bio} flows, describes the temporal C_{bio} emission profiles on an annual basis. The sum of negative and positive C_{bio} values per year, form the C_{bio} balance, representing the dynamic biogenic inventories that can subsequently be assessed by means of the dynamic LCIA method.

3.1.3. Complete carbon flows of a specific year

The dynamic inventories, both from fossil and biogenic sources, can be presented for a specific year of the modelled period. The calendar year representation is informative, as it details the flows and stocks of materials and energy on a key year of the policy-based scenario. We selected the year 2030, a future key target-year of the EU and national climate-energy policy [110], generating top FoWooR supply estimates in the 15Bio scenario of the transport sub-sector. All fossil and biogenic input and output flows were expressed in Mt C. Conversion factors from the EC-JRC [80] were used to express all inventoried petroleum and biomass feedstocks as C. For the FoWooR commodity, we used the weighted mean of C content in wood (0.4952) from the C_{bio} model [77]. The elementary C flows from the feedstock supply, transformation, use and EOL, were plotted in a Sankey-style diagram, using the STAN v6.2 software [111]. The incoming C embedded in petroleum fuels and biofuels equals the outgoing C embedded in atmospheric emissions. Losses from biochemical or thermochemical processes in biofuel production pathways are presented here as wastes. The biofuel from residual lignocellulosic material yield of biochemical processes generates between 110 and 300 litres [26] of

bioethanol per dry tonne of wood, with low heating values between 21.1 [26] and 26.8 MJ per litre [112]. The overall conversion efficiency of biochemical process pathway (likewise thermo-chemical processes) is about 35%.

The C flows (fossil + biogenic) of the transport sub-sector under the BAU and 15Bio scenarios are shown in Fig. 6a and Fig. 6b, respectively. The biogenic flow (5.3 Mt C) shown in Fig. 6b corresponded to the C_{bio} balance of fixation + release dynamics at the year 2030. The total emitted Mt of C, including the biogenic flows, is higher for the 15Bio scenario by 4.5 Mt C. Without the biogenic flows, C outputs would be lower for 15Bio. For the specific calendar year 2030, the C_{bio} balance results revealed the highest value from fixation and release, which then decreased to zero in the year 2050. The comparison among the scenarios showed that biogenic flows were only linked with the 15Bio for the transport sub-sector. This questions whether the comparison with the BAU reference is valid. This issues is further addressed in section 3.3 with the introduction of a hypothetical BAU* scenario associated with a C_{bio} balance featuring an alternative EOL pathway.

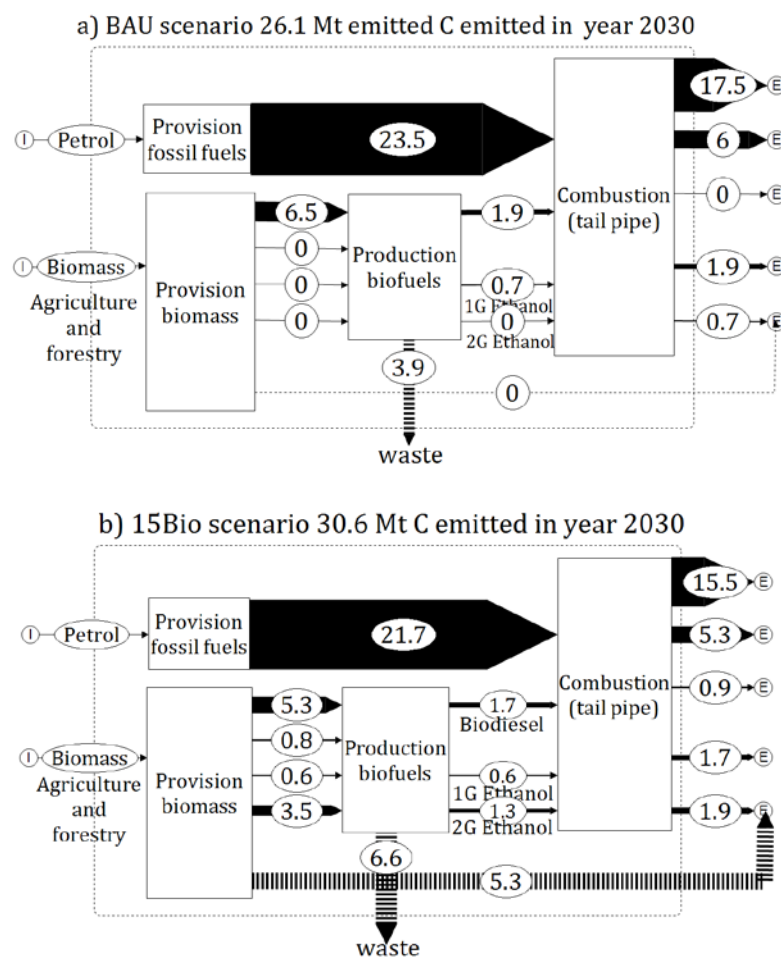

Fig. 6. Carbon flows [Mt C] of the year 2030, as Sankey-type diagrams, from biogenic and fossil sources of the transport sub-sector of a) BAU and b) 15Bio scenarios. Advanced second generation biofuels are not accounted for in the BAU scenario

3.2. Dynamic climate change impact results from the transport and bioethanol systems

The dynamic impact assessment of the inventoried GHG emissions was performed with time-dependent CFs [47], expressed as relative climate change impact in Mt CO₂-eq. The LCIA TH is variable in the dynamic method, and therefore an end year for the characterisation must be chosen by the practitioner to compare the results. We set the end year to 2119, 100-years into the future from the first PEM simulation year (2019). The climate impact is computed per scenario as shown in Fig. 7, for both the transport sub-sector (Fig. 7a) and the FoWooR-based 2G bioethanol (Fig. 7b). The impacts per system and scenario were compared as per two sets of results, namely one based on C neutral estimates (without C_{bio}) and on complete C estimates (with C_{bio}). Note that the BAU scenario revealed no climate change impact from C_{bio}, since no C_{bio} balance (i.e. from 2G bioethanol) has been accounted in the reference simulations.

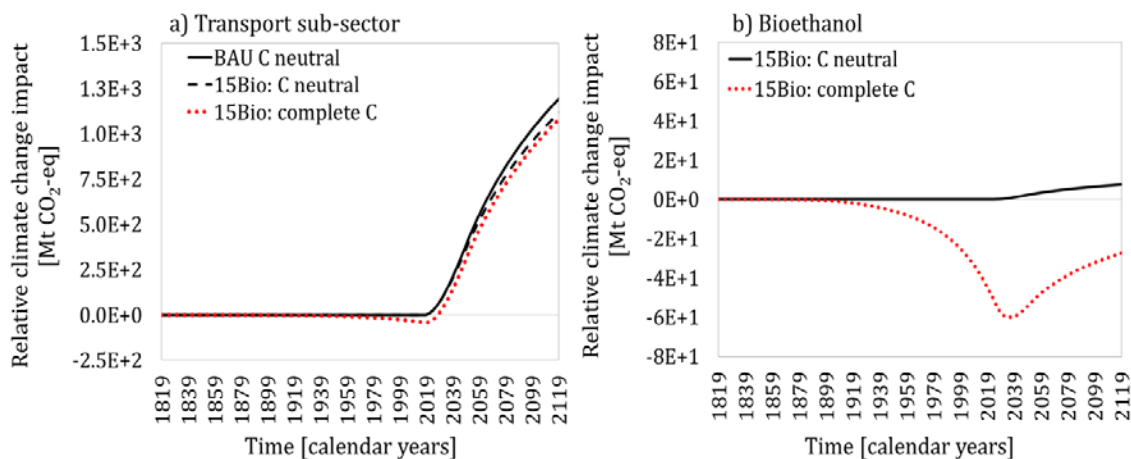

Fig. 7. Relative climate change impact [Mt CO₂-eq], assessed by means of time-dependent characterisation factors based on the radiative forcing method for a) the transport sub-sector, and b) the bioethanol systems

The climate change impact shown in Fig. 7a was based on all GHG emissions of the overall transport flows (i.e. production and consumption of petroleum fuels and biofuels). The climate change impact in 2119 would result in 1.19E3 and 1.11E3 Mt CO₂-eq, for BAU and 15Bio respectively. The new set of policies mitigates the climate change effects by 7% more, compared to BAU in the year 2119. The impacts remained under the BAU curve, even with projections beyond the selected chosen end year (not shown in Fig. 7a). Yet, fossil-based results of both scenarios demonstrated a continuous increase of the atmospheric impacts. This is due to the annually accumulated impacts and the long-term persistency of the dominant gas in the atmosphere (CO₂). Even though CH₄ and N₂O have a higher perturbation capacity in the atmosphere, the atmospheric residence lifetime (i.e. removal time in the atmosphere) of the reference CO₂ gas is in the order of thousands of years [44].

A comparison between the C neutral and the complete C results for transport, across scenarios (Fig. 7a), revealed that the climate change impact, and thus the mitigation effect from C_{bio} estimates from

the BAU reference scenario, are zero (as no FoWooR have been accounted for). Therefore, the comparison between C neutral and complete C was only valid for the 15Bio scenario. The 15Bio complete C impacts amount to 1.08E3 Mt CO₂-eq in the year 2019. Compared with the 15Bio C neutral impact (1.11E3 Mt CO₂-eq), it results in a mitigation effect of about 3%. This means that the inclusion of the dynamic C_{bio} would lead to a higher mitigation effect than for 15Bio C neutral estimates. The reduction draws back to the inventoried historic long-term sequestration period. This effect is sustained far into the future, until a steady-state is achieved after about one thousand years (not shown in Fig. 7a). That is to say, in the distant future the complete C impacts become equivalent to the C neutral impacts.

Such a small estimated mitigation effect from the 15Bio complete C of the transport sub-sector, is due to the dynamic C_{bio} balance corresponding exclusively to the FoWooR-based 2G bioethanol pathway, which is minimal compared with all fossil sourced emissions from the entire transport sector. The total 15Bio contributions of FoWooR to the transport sub-sector, in the peak year 2030, amounted to 17% of the primary biomass share and 3% of the final energy consumption. The allocation of C_{bio} emissions to the overall transport system were thus not significantly contributing in the 15Bio simulations. Therefore, an allocation of the C_{bio} emissions restricted to the FoWooR-bioethanol pathway was undertaken to provide insights into the climate change impact and mitigation effect of the bioethanol system.

Results from the bioethanol system are shown in Fig. 7b. For the impact assessment of bioethanol, the following conversion factors were applied to the 15Bio FoWooR outputs: low heating value of 18.5 MJ·kg⁻¹, bioethanol yield of 0.3428 MJ_{Ethanol}·MJ_{wood}⁻¹, and fossil-based GHG emission factor of 19.5 g CO₂-eq·MJ_{Ethanol}⁻¹. The CO₂-equivalent values were recalculated proportional to the respective CO₂, CH₄ and N₂O elementary flows given by the EC-JRC [80] and divided by the default IPCC GWP100 equivalent factors [44]. The complete C balance included the dynamic biogenic emissions from C_{bio} fixation and C_{bio} combustion EOL of FoWooR. The C neutral estimates from bioethanol production were calculated using the EC-JRC WTW method for EU farmed or waste wood-to-bioethanol pathways [80]. The cumulative bioethanol production from the FoWooR output associated with the 15Bio scenario over the entire PEM simulation TH amounted to 1.04E12 MJ_{Ethanol}, which corresponds to a carbon footprint of 2.03E7 Mt CO₂-eq (when using the static GWP100). A comparison between the absolute value of the total dynamic biogenic emissions from either C_{bio} fixation or combustion (3.72E2 Mt CO₂-eq) and the total fossil emissions from bioethanol production (2.03E7 Mt CO₂-eq), demonstrated that the fossil sourced emissions represented only about 5.4% of all emissions from the bioethanol system. Although the comparison is static —all technical and elementary flows are summed up in the year 2019, equivalent to the year zero in static inventories—, the outcomes have shown the difference in orders of magnitude between the fossil and biogenic emissions in the bioethanol system.

The relative climate change results from bioethanol (Fig. 7b) in the year 2119 resulted in $7.55E0$ Mt CO₂-eq for C neutral and $-2.74E1$ Mt CO₂-eq for complete C. Note that for the BAU scenario has zero impact, as no C_{bio} balance from FoWooR was accounted for and thus no production of bioethanol was modelled. A comparison between the two results for 15Bio Bioethanol showed that the climatic impacts for complete C are negative, implying that the sequestration is larger than the positive impact from the release. These complete C results would reduce those of C neutral results by 462%. Such high mitigation effect is explained by the low contribution (5.4%) of fossil sourced emissions to the total bioethanol emissions, and the duration of inventoried (historic) long-term sequestration. Projections beyond the year 2119, revealed that the complete C results would continuously converge towards the C neutral curve. The climate mitigation effect is thus sensitive to a specific year or selected future reference year (i.e. end year of the LCIA impact assessment), as the LCIA TH is variable.

Additionally, we calculated a dynamic emission factor for bioethanol from FoWooR. First, the relative climate impact for the C_{bio} balance (i.e. biogenic only) was computed the year 2119, resulting in $-3.49E7$ Mt CO₂-eq. This negative value was subsequently divided by the total FoWooR-bioethanol production ($1.04E12$ MJ_{Ethanol}). The resulting dynamic emission factor (-33.6 g CO₂-eq·MJ_{Ethanol}⁻¹) was contrasted with the EC-JRC static emission for wood residues from farmed forestry (19.5 g CO₂-eq·MJ_{Ethanol}⁻¹). A comparison between these factors demonstrates that the dynamic factor is negative, which would imply that the climate impact from bioethanol production could be reduced by 272%, an almost three-fold reduction for this specific policy scenario. This negative factor derives from the historic long-term C_{bio} sequestration period assessed in this study. However, the more distant into the future the reference year is set to, the lower the mitigation effect becomes, as the impact from biogenic sources approach C neutral results. That is to say, the negative atmospheric impact from sequestration is reduced through the positive impact from combustion.

3.3. Comparison of bioethanol impacts with an alternative reference scenario

For the bioethanol system a comparison was undertaken between the 15Bio scenario and a hypothetical BAU* reference scenario featuring a C_{bio} balance with an alternative EOL pathway. This comparison was performed because the previous BAU reference results were zero due to the absence of a C_{bio} balance estimate. We therefore assumed a reference system, in which FoWooR from logging operations are left behind instead of being used for the transport sub-sector. The hypothetical C_{bio} balance for the BAU* scenario was composed from C_{bio} fixation and C_{bio} decay flows. It accounted for the same mass of FoWooR described in the 15Bio scenario with the same historic full-rotation length of 200 years (see section 2.3.1).

Fig. 8a shows the C_{bio} balance from BAU* and 15Bio. The BAU* C_{bio} fixation values were equal to those inventoried in the C_{bio} balance of the 15Bio scenario. The flows from the EOL options however

differed for combustion and decay. A comparison between the two inventoried EOL flows, indicated that the BAU* gradual decay of FoWooR shifted the release of emissions further into the future, as compared with the instant emissions from combustion. The last release flow from combustion occurred in the year 2050. For the decay, the last flow was estimated in the year 2119, although <0.01% of the carbon remained in the technosphere. We neglected those remaining emissions and assumed that until the year 2119 the total embedded carbon in the FoWooR returned to the atmosphere.

Fig. 8b shows the relative climate change impact from the bioethanol system for BAU* and 15Bio. For bioethanol C neutral results (i.e. fossil based) are equal for both BAU* and 15Bio, amounting to 7.55E0 Mt CO₂-eq in the year 2119. The impact results of the complete C estimates would attain in Mt CO₂-eq 3.14E1 and -2.74E01 for BAU* and 15Bio respectively. The results for the BAU* with EOL decay are positive compared to those of 15Bio with combustion. This implies that the C neutral results from BAU* or 15Bio would be increased by 316%. This large difference compared to 15Bio derived from the presence of short-lived CH₄, with high perturbation capacity, that was only considered in the EOL of BAU*. The CH₄ decay emissions amounted to 10% of the total emissions associated with belowground biomass ratio, corresponding to the aboveground FoWooR, with a half-life of 30 years.

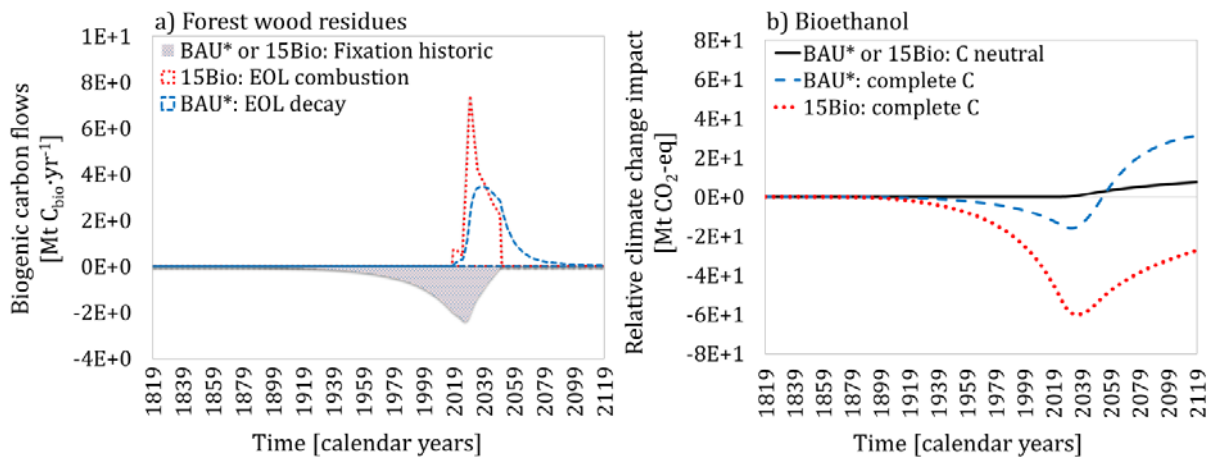

Fig. 8: a) Dynamic biogenic carbon [C_{bio}] balance of forest wood residues [Mt C_{bio}·yr⁻¹] with fixation and two EOL options concerning combustion (15Bio scenario) and decay (BAU* alternative scenario), and b) relative climate change impact [Mt CO₂-eq] of the bioethanol system of both scenarios BAU* and 15Bio

3.4. Sensitivity analysis

To test the sensitivity of the C_{bio} model to the values of its key parameters, such as the growth rate, we recalculated tree growth for all species with extreme initial values for all the parameters (from the acceptable range of values indicated in the literature). The acceptable range of values for the growth rate parameter k (growth rate) lied between 0.2 and 2.5. The CR model is rather robust and converges

towards the originally computed results. The model is thus very flexible and accurate, yet it confirms its validity to the “slight expense of biological realism” [113].

Additionally, a sensitivity analysis was performed concerning the rotation length for the C_{bio} fixation of the 15Bio scenario. The previously applied 200-year full rotation length was contrasted against 131 years, which is the weighted mean of rotation lengths of all tree species assessed in the C_{bio} fixation model. For differentiation purposes, the scenario with the alternative full rotation length was named 15Bio*. Fig. 9 shows the sensitivity between the two rotation lengths for both systems under assessment, namely, the transport sub-sector and the bioethanol. The dynamic climate change impact, as per the complete C balance, was compared for 15Bio and 15Bio*. The alternative rotation length generated a new LCI TH, as the first fixation year shifted from 1819 to 1888. The end year 2119 would generate the following climate change impact in Mt CO₂-eq: for the transport sub-sector 1.08E3 (15Bio) and 1.36E3 (15Bio*), and for bioethanol -2.74E1 (15Bio) and 7.28E1 (15Bio*). The outcomes revealed high sensitivity for the rotation length of the C_{bio} fixation: the shorter the length the lower the mitigation effect (expressed as the difference with C neutral estimates).

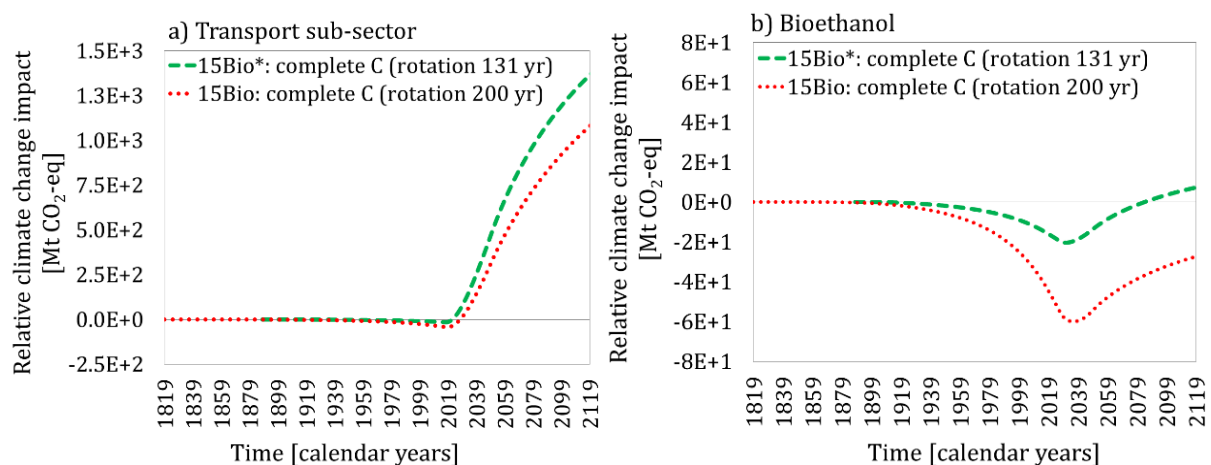

Fig. 9. Sensitivity analysis of the 15Bio scenario concerning the full rotation lengths applied for modelling C_{bio} fixation. Compared are the climate change impact [Mt CO₂-eq] from the complete carbon [C] balance, involving a full rotation length of 200 years and 131 years for a) transport sub-sector and b) bioethanol system. The first year of the 200-year rotation length is 1819, and for the 131-year it is 1888

3.5. Overall discussion

The comparison between TIMES-MIRET PEM scenarios revealed relevant insights into the changes of energy-transport dynamics induced by new policy constraints associated with climate change mitigation and low-carbon energy strategies. Consequences from the 15Bio policy —limiting 1G biofuel share to 7% and increasing the renewable energy share by 15% by 2030— are shown through the changes in the new biomass commodity and energy pathways for the production of advanced biofuels. Non-food crop-based biomass resources (i.e. FoWooR, agricultural residues and dedicated

LGC material) were introduced to the transport sub-sector as renewable resources linked with competitive biofuel processes. The mobilisation of FoWooR supply to the transport was linked to cellulosic bioethanol, the main 2G transport biofuel under the 15Bio scenario.

The dynamic accounting of C_{bio} allowed a complete assessment of both fixation and release flows of FoWooR over time. Dynamic C_{bio} modelling and coupling with the PEM (in principle replaceable with other economic models) demonstrated the relevance of including C_{bio} emissions in the assessment of bioenergy systems. The annual biogenic values are not carbon neutral and, therefore, not zero. The historic rotation length in this study was based on a 200-year period, which is the maximum sequestration period in the French forest wood supply chain. However, the sensitivity analysis has proven that the mitigation effect from sequestration is sensitive to chosen rotation length modelling. The shorter the length the lower is the difference between the C neutral and complete C estimates.

To date, no modelling consensus exists for the initial C_{bio} fixation flow when assessing forest wood use from managed or non-managed systems. The first year of the C_{bio} fixation flow confronts the so-called chicken-or-egg causality dilemma [107]. We accounted for historic C_{bio} flows, as practiced by other authors [67,94–97,107], following an economic point of view of the technosphere. The residues from logging operation are considered as a co-product from the forest wood supply chain, when collected for the energy sector. The co-product is thus destined to meet the raw material requirements of emerging 2G biofuels. The selection of the modelling perspective is thus based on the origin of a biotic resource. That is to say, to meet the market requirements for future advanced biofuel production, the biotic resource extraction (e.g. FoWooR) derives from “man-made controlled culture” and not from nature [98]. Controlled cultures are, for instance, agriculture, aquaculture and silviculture/forestry. These systems experience a higher level of human interventions to meet the requirements of the market demand, and are thus considered as a part of the technosphere. For valuing C_{bio} fixation and sequestration and appropriately assess climate change mitigation targets, the different modelling approaches should be further studied and contrasted.

Furthermore, the C_{bio} model relied on empirical data from long-term field studies, tabulated into yield tables, to predict the mean tree growth dynamic and carbon fixation. The sensitivity analysis has demonstrated the robustness and flexibility of the C_{bio} model tool developed for this study. It is operational for any type of wood-based products, also cross-sectoral (e.g. wood for construction or paper industry). However, the model did not consider site-specific parameters, such as unexpected losses (e.g. diseases, wildfires). Potential losses from mortality and diseases, for France, were taken into consideration in the input data of the PEM. However, for other case specific applications, these site-dependent parameters would further improve dynamic approaches and reduced uncertainties. Further studies should be conducted to extend C_{bio} modelling to other biomass types (e.g. short rotation coppice and perennial crops) and alternative EOL pathways.

The relative climate change results demonstrated that the substitution of fossil fuel feedstock by renewables contributes to climate change mitigation. The inclusion and assessment of the C_{bio} balance further reduced the carbon neutral estimates. The mitigation effect of the bioethanol systems was significantly larger than that of the overall transport sub-sector: the 15Bio C neutral results would be lowered by 462% and 3% for bioethanol and transport respectively. The high mitigation effect for the bioethanol is explained by the relative contribution of the fossil sourced GHG emissions in the two systems, and the historic long-term sequestration period of wood. For bioethanol, fossil emissions represented only 5.4% of the total emissions. The negative impact, implying sequestration, gradually increases with projections beyond the end year 2119, as they are reduced by the positive fossil and biogenic emissions from the release. In contrary, the hypothetical BAU* scenario with decay EOL revealed higher impact for the complete C, meaning that the C neutral estimates would be increased by 316%.

Moreover, for FoWooR-based 2G bioethanol, a dynamic emissions factor was computed and compared with the static EC-JRC emission factor. This representation requires careful interpretation. A direct comparison between the relative impact from static (GWP100) and dynamic (time-dependent CFs) methods is not directly possible, as both have different impact representations. The main inconsistency lies between the different time horizons generated by the different emission years [47,51]. The static approach assigns the same impact characterisation to all emissions. That is to say, all inventoried GHG emissions are aggregated and characterised in the same way. The GWP100 results express the effects of all aggregate GHG emissions in year zero (in static inventories with no time consideration) and the year 100. The fixed TH ignores the temporal variability of the flows and their time-sensitive impact.

The dynamic method, on the other hand, has no fixed TH and is thus variable, representing the actual impact for any given characterisation TH. A reference year, or end year of the LCIA TH, needs to be defined to enable a comparison among different scenario results, as done in the present study. The end year of the assessment thus expresses the climatic effects between the year of each GHG emission and the chosen reference year. For instance, with the chosen end year 2119, the LCIA TH of the impact representation for the GHG emissions inventoried in the year 2019 is 100 years (2119 minus 2019), for those inventoried in the year 2050 is 69 years (2119 minus 2050), and so forth. Thus, the representation of the impact differs from that of static approaches.

For valuing the temporary C_{bio} fixation and sequestration in emerging bioenergy systems, the use of dynamic impact assessment approaches is more appropriate, as demonstrated with the model coupling. Recent studies [76,106] thoroughly discuss the shortcomings of using the single GWP metric and encourage the use of different metrics to more accurately assess climate change and mitigation efforts. We recommend the dynamic method to take into account the temporal GHG emission profiles of C_{bio}

and fossil sources. If time is not taken into consideration, positive and negative impact contributions of biogenic emissions sum up to zero, thus yielding the same steady state result as carbon neutral estimates. Further research is needed to address the spatially-explicit dynamic impacts for forest bioenergy applications (e.g. concerning albedo effects, land-use change, soil organic carbon), as highlighted in various studies [64,114–117]. This implies the assessment of other impact categories, as intended by LCA.

Higher mitigation targets and restrictions of 1G biofuels may mobilise larger quantities of FoWooR or other biomass resources for the production of 2G biofuels. This raises the question: what would be the consequences of a demand change in other sectors or economies, if the demand for a specific biomass (e.g. energy crops, dedicated wood) increases significantly? Cross-sectoral interactions are not analysed in the PEM. This could be addressed by means of full CLCA, which intends to determine the biophysical changes that one life cycle could have on other life cycles (including indirect effects such as land use change) as a consequence of a decision [118]. Consequential approaches would further complement the analysis and provide meaningful insights into the shifting market- and macroeconomic dynamics (i.e. the effects that the substitution of fossil fuels by biofuels could have on other life cycles or sectors).

4. Conclusions

The proposed model coupling was successfully implemented, yielding meaningful information on how to assess biogenic carbon of bioenergy systems and emerging renewable energy pathways in response to any policy scenario. The coupled model combines crosscutting aspects of energy system analysis and forest carbon modelling in the specific context of dynamic LCA and climate change mitigation. The proposed strategy challenges the current static carbon neutral and renewable energy displacement approaches by means of dynamic assessment of biogenic carbon and time sensitive climate change impacts. The biogenic carbon models are applicable to specific cases and the parametrisation can be refined to site-specific conditions if needed. The C_{bio} modelling tool developed for this study is available upon request to the corresponding author.

Prospective models of emerging markets support policy-decision making of a specific sector by means of different scenario comparisons. The consideration of technological innovation and market dynamics in a transitioning energy system expands the assessment boundaries commonly used in attributional LCA. The PEM provides insights into economic optimisation of energy-transport pathways and climate change mitigation potentials. Studies should be further complemented with other environmental impact categories and other externalisations involving indirect effects (e.g. land use change and soil organic carbon). Future refinements of spatially-explicit dynamics and other impact categories should follow suit.

Acknowledgments

This work has been supported by IFP Energies nouvelles by means of a doctoral grant. We would like to thank the division of Economics & Technology Intelligence at IFPEN.

References for Paper 1

- [1] UNFCCC. Climate Get the Big Picture - A guide to the UNFCCC and its processes. United Nations Conv Clim Chang 2018. <https://bigpicture.unfccc.int/> (accessed January 1, 2018).
- [2] MTES. Loi de transition énergétique pour la croissance verte. Ministère La Transit Écologique Solidaire 2018. <https://www.ecologique-solidaire.gouv.fr/loi-transition-energetique-croissance-verte> (accessed January 29, 2018).
- [3] Nicolas C, Saint-Antonin V, Tchung-Ming S. (How) does sectoral detail affect the robustness of policy insights from energy system models? The refining sector's example. Université de Paris Ouest Nanterre La Défense. Paris: 2014.
- [4] Gargiulo M, Brian O. Long-term energy models: Principles, characteristics, focus, and limitations. *WIREs Energy Env* 2013;2:158–177. doi:10.1002/wene.62.
- [5] Loulou R, Goldstein G, Kanudia A, Lettila A, Remme U. Documentation for the TIMES Model Part I. Energy Technology Systems Analysis Programme: 2016.
- [6] Böhringer C, Rutherford TF. Integrated assessment of energy policies: Decomposing top-down and bottom-up. *J Econ Dyn Control* 2009;33:1648–61. doi:10.1016/j.jedc.2008.12.007.
- [7] IEA-ETSAP. TIMES Modelling Tool. Int Energy Agency Energy Technol Syst Anal Progr 2018. <https://iea-etsap.org/> (accessed January 29, 2018).
- [8] Glynn J, Fortes P, Krook-Riekkola A, Labriet M, Vielle M, Kypreos S, et al. Part III Economic Impacts of Future Changes in the Energy System—Global Perspectives .. In: Giannakidis G, Labriet M, Gallachóir BÓ, Tosato G, editors. *Informing energy Clim. policies using energy Syst. Model. Insights from Scenar. Anal. increasing Evid. base*, vol. 30, Cham Heidelberg New York Dordrecht London: Springer International Publishing Switzerland; 2015, p. 333–58. doi:10.1007/978-3-319-16540-0.
- [9] Loulou R, Goldstein G, Noble K. Documentation for the MARKAL Family of Models. ETSAP-Energy Technology Systems Analysis Programme: 2004.
- [10] Cherp A, Vinichenko V, Jewell J, Brutschin E, Sovacool B. Integrating techno-economic, socio-technical and political perspectives on national energy transitions: A meta-theoretical framework. *Energy Res Soc Sci* 2018;37:175–90. doi:10.1016/j.erss.2017.09.015.
- [11] Böhringer C, Rutherford TF. Combining bottom-up and top-down. *Energy Econ* 2008;30:574–96. doi:10.1016/j.eneco.2007.03.004.
- [12] Benoist A, Dron D, Zoughaib A. Origins of the debate on the life-cycle greenhouse gas emissions and energy consumption of first-generation biofuels - A sensitivity analysis approach. *Biomass and Bioenergy* 2012;40:133–42. doi:10.1016/j.biombioe.2012.02.011.

- [13] Rathmann R, Szklo A, Schaeffer R. Land use competition for production of food and liquid biofuels: An analysis of the arguments in the current debate. *Renew Energy* 2010;35:14–22. doi:10.1016/j.renene.2009.02.025.
- [14] Harvey M, Pilgrim S. The new competition for land: Food, energy, and climate change. *Food Policy* 2011;36:S40–51. doi:10.1016/j.foodpol.2010.11.009.
- [15] Rosa M De, Knudsen MT, Hermansen JE. A comparison of Land Use Change models : challenges and future developments. *J Clean Prod* 2016;113:183–93. doi:10.1016/j.jclepro.2015.11.097.
- [16] Majer S, Mueller-langer F, Zeller V, Kaltschmitt M. Implications of biodiesel production and utilisation on global climate – A literature review. *Eur J Lipid Sci Technol* 2009;111:747–62. doi:10.1002/ejlt.200900045.
- [17] Sahoo K, Bilek E, Bergman R, Mani S. Techno-economic analysis of producing solid biofuels and biochar from forest residues using portable systems. *Appl Energy* 2019;235:578–90. doi:10.1016/j.apenergy.2018.10.076.
- [18] Cambero C, Sowlati T. Assessment and optimization of forest biomass supply chains from economic, social and environmental perspectives - A review of literature. *Renew Sustain Energy Rev* 2014;36:62–73. doi:10.1016/j.rser.2014.04.041.
- [19] Gustavsson L, Haus S, Ortiz CA, Sathre R, Truong N Le. Climate effects of bioenergy from forest residues in comparison to fossil energy. *Appl Energy* 2015;138:36–50. doi:10.1016/j.apenergy.2014.10.013.
- [20] Sahoo K, Hawkins GL, Yao XA, Samples K, Mani S. GIS-based biomass assessment and supply logistics system for a sustainable biorefinery : A case study with cotton stalks in the Southeastern US. *Appl Energy* 2016;182:260–73. doi:10.1016/j.apenergy.2016.08.114.
- [21] Yang J, Chen B. Global warming impact assessment of a crop residue gasification project-A dynamic LCA perspective. *Appl Energy* 2014;122:269–79. doi:10.1016/j.apenergy.2014.02.034.
- [22] Cherubini F, Ulgiati S. Crop residues as raw materials for biorefinery systems – A LCA case study. *Appl Energy* 2010;87:47–57. doi:10.1016/j.apenergy.2009.08.024.
- [23] Shemfe MB, Whittaker C, Gu S, Fidalgo B. Comparative evaluation of GHG emissions from the use of Miscanthus for bio-hydrocarbon production via fast pyrolysis and bio-oil upgrading. *Appl Energy* 2016;176:22–33. doi:10.1016/j.apenergy.2016.04.113.
- [24] Perrin A, Wohlfahrt J, Morandi F, Østergård H, Flatberg T, La C De, et al. Integrated design and sustainable assessment of innovative biomass supply chains : A case-study on miscanthus in France. *Appl Energy* 2017;204:66–77. doi:10.1016/j.apenergy.2017.06.093.
- [25] Alonso DM, Hakim SH, Zhou S, Won W, Hosseinaei O, Tao J, et al. Increasing the revenue from lignocellulosic biomass : Maximizing feedstock utilization. *Sci Adv* 2017;3:1–7. doi:10.1126/sciadv.1603301.

- [26] Slims R, Taylor M. From 1st to 2nd generation biofuel technology- An overview of current industry and RD&D activities. P. 44-45. OECD/IEA-International Energy Agency. Paris: 2008.
- [27] Alba Departe, Filmon K, Houdon A-C, Bal J-L, Clément D, Boniface L, et al. Feuille de route biocarburants avancés. ADEME-Agence de l'environnement et de La Maîtrise de l'énergie. Paris: 2011.
- [28] Naik SN, Goud V V, Rout PK, Dalai AK. Production of first and second generation biofuels: A comprehensive review 2010;14:578–97. doi:10.1016/j.rser.2009.10.003.
- [29] Muench S, Guenther E. A systematic review of bioenergy life cycle assessments. *Appl Energy* 2013;112:257–73. doi:10.1016/j.apenergy.2013.06.001.
- [30] Levasseur A, Bahn O, Beloin-Saint-Pierre D, Marinova M, Vaillancourt K. Assessing butanol from integrated forest biorefinery: A combined techno-economic and life cycle approach. *Appl Energy* 2017:1–13. doi:10.1016/j.apenergy.2017.04.040.
- [31] Menten F, Tehung-ming S, Lorne D, Bouvart F. Lessons from the use of a long-term energy model for consequential life cycle assessment: The BTL case. *Renew Sustain Energy Rev* 2015;43:942–60. doi:10.1016/j.rser.2014.11.072.
- [32] García-Gusano D, Iribarren D, Garraín D. Prospective analysis of energy security: A practical life-cycle approach focused on renewable power generation and oriented towards policy-makers. *Appl Energy* 2017;190:891–901. doi:10.1016/j.apenergy.2017.01.011.
- [33] Earles JM, Halog A, Ince P, Skog K. Integrated economic equilibrium and life cycle assessment modeling for policy-based consequential LCA. *J Ind Ecol* 2013;17:375–84. doi:10.1111/j.1530-9290.2012.00540.x.
- [34] Miller SA, Moysey S, Sharp B, Alfaro J. A Stochastic Approach to Model Dynamic Systems in Life Cycle Assessment. *J Ind Ecol* 2013;17:352–62. doi:10.1111/j.1530-9290.2012.00531.x.
- [35] Earles JM, Halog A. Consequential life cycle assessment: A review. *Int J Life Cycle Assess* 2011;16:445–53. doi:10.1007/s11367-011-0275-9.
- [36] Eriksson O, Finnveden G, Ekvall T, Björklund A. Life cycle assessment of fuels for district heating: A comparison of waste incineration, biomass- and natural gas combustion. *Energy Policy* 2007;35:1346–62. doi:10.1016/j.enpol.2006.04.005.
- [37] Collet P, Flottes E, Favre A, Raynal L, Pierre H, Capela S, et al. Techno-economic and life cycle assessment of methane production via biogas upgrading and power to gas technology. *Appl Energy* 2017;192:282–95. doi:10.1016/j.apenergy.2016.08.181.
- [38] Marvuglia A, Benetto E, Rege S, Jury C. Modelling approaches for consequential life-cycle assessment (C-LCA) of bioenergy: Critical review and proposed framework for biogas production. *Renew Sustain Energy Rev* 2013;25:768–81. doi:10.1016/j.rser.2013.04.031.
- [39] Ekvall T, Weidema BP. System Boundaries and Input Data in Consequential Life Cycle Inventory Analysis. *Int J Life Cycle Assess* 2004;9:161–71. doi:10.1065/Ica2004.03.148.

Chapter 4: Forestry: growth modelling

- [40] Curran MA, Mann M, Norris G. The international workshop on electricity data for life cycle inventories. *Clean Prod* 2005;13:853e862. doi:10.1016/j.jclepro.2002.03.001.
- [41] Vázquez-Rowe I, Marvuglia A, Rege S, Benetto E. Applying consequential LCA to support energy policy: Land use change effects of bioenergy production. *Sci Total Environ* 2014;472:78–89. doi:10.1016/j.scitotenv.2013.10.097.
- [42] Vázquez-Rowe I, Rege S, Marvuglia A, Thénie J, Haurie A, Benetto E. Application of three independent consequential LCA approaches to the agricultural sector in Luxembourg. *Int J Life Cycle Assess* 2013;18:1593–604. doi:10.1007/s11367-013-0604-2.
- [43] Kløverpris J, Wenzel H, Nielsen PH. Life cycle inventory modelling of land use induced by crop consumption: Part 1: Conceptual analysis and methodological proposal. *Int J Life Cycle Assess* 2008;13:13–21. doi:10.1065/lca2007.10.364.
- [44] Myhre G, Shindell D, Bréon F-M, Collins W, Fuglestvedt J, Huang J, et al. Chapter 8 Anthropogenic and Natural Radiative Forcing. In: Stocker, T.F., D. Qin, G.-K. Plattner, M. Tignor, S.K. Allen, J. Boschung, A. Nauels, Y. Xia VB and PMM (eds.).., editor. *Clim. Chang. 2013 Phys. Sci. Basis. Contrib. Work. Gr. I to Fifth Assess. Rep. Intergov. Panel Clim. Chang.* [Stocker, T.F., D. Qin, G.-K. Plattner, M. Tignor, S.K. Allen, J. Boschung, A. Nauels, Y., Cambridge, United Kingdom and New York: Cambridge University Press; 2013, p. 659–740. doi:10.1017/CBO9781107415324.018.
- [45] Hellweg S, Frischknecht R. Evaluation of Long-Term Impacts in LCA. *Conf. Reports 22nd Discuss. Forum LCA*, vol. 9, 2004, p. 339–41.
- [46] Reap J, Roman F, Duncan S, Bras B. Part 2 : impact assessment and interpretation. *Int J Life Cycle Assess* 2008;374–88. doi:10.1007/s11367-008-0009-9.
- [47] Levasseur A, Lesage P, Margni M, Deschênes L, Samson R. Considering time in LCA: Dynamic LCA and its application to global warming impact assessments. *Environ Sci Technol* 2010;44:3169–74. doi:10.1021/es9030003.
- [48] Jørgensen S V, Hauschild MZ, Nielsen PH. The potential contribution to climate change mitigation from temporary carbon storage in biomaterials. *Int J Life Cycle Assessment* 2015;451–62. doi:10.1007/s11367-015-0845-3.
- [49] Kendall A, Davis A, Studies T, Shields O, Davis A, Sharpe B. Accounting for time-dependent effects in biofuel life cycle greenhouse gas emissions calculations. *Environ Sci Technol* 2009;43:7142–7. doi:10.1021/es900529u.
- [50] Sevenster M. Linear Approaches to Characterization of Delayed Emissions of Methane. *J Ind Ecol* 2014;18:809–17. doi:10.1111/jiec.12136.
- [51] Benoist A. Eléments d’adaptation de la méthodologie d’analyse de cycle de vie aux carburants végétaux : cas de la première génération. PhD thesis. École Nationale Supérieure des Mines de Paris, 2009.
- [52] Clift R, Brandao M. Carbon storage and timing of emissions - a note by Roland Clift and Miguel Brandao. Guildford: 2008.

- [53] Pawelzik P, Carus M, Hotchkiss J, Narayan R, Selke S, Wellisch M, et al. Critical aspects in the life cycle assessment (LCA) of bio-based materials - Reviewing methodologies and deriving recommendations. *Resour Conserv Recycl* 2013;73:211–28. doi:10.1016/j.resconrec.2013.02.006.
- [54] Matthews R, Sokka L, Soimakallio S, Mortimer N, Rix J, Schelhaas M, et al. Review of literature on biogenic carbon and life cycle assessment of forest bioenergy: Final Task 1 report, EU DG ENER project ENER/C1/427, 'Carbon impacts of biomass consumed in the EU.' Farnham: Forest Research: 2014.
- [55] Brandão M, Levasseur A, Kirschbaum MUF, Weidema BP, Cowie AL, Jørgensen SV, et al. Key issues and options in accounting for carbon sequestration and temporary storage in life cycle assessment and carbon footprinting. *Int J Life Cycle Assess* 2013;18:230–40. doi:10.1007/s11367-012-0451-6.
- [56] Searchinger TD, Hamburg SP, Melillo J, Chameides W, Havlik P, Kammen DM, et al. Fixing a critical climate accounting error. *Sci* 326(5952):527–528 2009;326:527–8. doi:10.1126/science.1178797.
- [57] Cherubini F, Peters GP., Berntsen T, Strømman AH., Hertwich EG. CO₂ emissions from biomass combustion for bioenergy: atmospheric decay and contribution to global warming. *GCB Bioenergy* 2011;3:413–26. doi:10.1111/j.1757-1707.2011.01102.x.
- [58] Guest G, Bright RM, Cherubini F, Strømman AH. Consistent quantification of climate impacts due to biogenic carbon storage across a range of bio-product systems. *Environ Impact Assess Rev* 2013;43:21–30. doi:10.1016/j.eiar.2013.05.002.
- [59] Agostini A, Giuntoli J, Boulamanti A. Carbon accounting of forest bioenergy critical literature review. *EC JRC Scientific Policy Reports Rep EUR 25354* 2014:1–87. doi:10.2788/29442.
- [60] Levasseur A, Brandão M, Lesage P, Margni M, Pennington D, Clift R. Valuing temporary carbon storage. *Nat Clim Chang* 2012;2:1–3. doi:10.1038/nclimate1335.
- [61] Miguel Brandão and Annie Levasseur. Assessing temporary carbon storage in life cycle assessment and carbon footprinting: Outcomes of an expert workshop, 7th-8th October 2010, Ispra (Italy). 2010. doi:10.2788/22040.
- [62] Wiloso EI, Heijungs R, Huppel G, Fang K. Effect of biogenic carbon inventory on the life cycle assessment of bioenergy: Challenges to the neutrality assumption. *J Clean Prod* 2016;125:78–85. doi:10.1016/j.jclepro.2016.03.096.
- [63] Bird N, Cowie A, Cherubini F, Jungmeier G. Using a life cycle assessment approach to estimate the net greenhouse gas emissions of bioenergy. *IEA Bioenergy Secretariat. Whakarewarewa Rotorua*: 2011.
- [64] Bright RM, Cherubini F, Strømman AH. Climate impacts of bioenergy: Inclusion of carbon cycle and albedo dynamics in life cycle impact assessment. *Environ Impact Assess Rev* 2012;37:2–11. doi:10.1016/j.eiar.2012.01.002.
- [65] Pourhashem G, Adler PR, Spatari S. Time effects of climate change mitigation strategies for second generation biofuels and co-products with temporary carbon storage. *J Clean Prod* 2016;112:2642–53. doi:10.1016/j.jclepro.2015.09.135.

- [66] Cherubini F. GHG balances of bioenergy systems - Overview of key steps in the production chain and methodological concerns. *Renew Energy* 2010;35:1565–73. doi:10.1016/j.renene.2009.11.035.
- [67] Peñaloza D, Røyne F, Sandin G, Svanström M, Erlandsson M. The influence of system boundaries and baseline in climate impact assessment of forest products. *Int J Life Cycle Assess* 2018. doi:10.1007/s11367-018-1495-z.
- [68] De Rosa M, Schmidt J, Brandão M, Pizzol M. A flexible parametric model for a balanced account of forest carbon fluxes in LCA. *Int J Life Cycle Assess* 2017;22:172–84. doi:10.1007/s11367-016-1148-z.
- [69] Brandão M, Levasseur A. Assessing temporary carbon storage in life cycle assessment and carbon footprinting: outcomes of an expert workshop. *JRC 63225* 2010. doi:10.2788/22040.
- [70] Weiss M, Haufe J, Carus M, Brandão M, Bringezu S, Hermann B, et al. A Review of the Environmental Impacts of Biobased Materials. *J Ind Ecol* 2012;16. doi:10.1111/j.1530-9290.2012.00468.x.
- [71] Cornillier C, Benoist A, Gleizes O. Etude préliminaire à la réalisation de bilans environnementaux sur le chauffage au bois – Synthèse. 2015.
- [72] Joos F, Bruno M. Pulse response functions are cost-efficient tools to model the link between carbon emissions, atmospheric CO₂ and global warming. *Phys Chem Earth* 1996;21:471–6. doi:10.1016/S0079-1946(97)81144-5.
- [73] Yan Y. Integrate carbon dynamic models in analyzing carbon sequestration impact of forest biomass harvest. *Sci Total Environ* 2018;615:581–7. doi:10.1016/j.scitotenv.2017.09.326.
- [74] Owens JW. Life-Cycle Assessment Constraints: Constraints on Moving from Inventory to to Impact Assessment. *J Ind Ecol* 1997.
- [75] Collet P, Lardon L, Steyer JP, Hélias A. How to take time into account in the inventory step: A selective introduction based on sensitivity analysis. *Int J Life Cycle Assess* 2014;19:320–30. doi:10.1007/s11367-013-0636-7.
- [76] Cherubini F, Fuglestvedt J, Gasser T, Reisinger A, Cavalett O, Huijbregts MAJ, et al. Bridging the gap between impact assessment methods and climate science. *Environ Sci Policy* 2016;64:129–40. doi:10.1016/j.envsci.2016.06.019.
- [77] Albers A, Collet P, Benoist A, Hélias A. Data and non-linear models for the estimation of biomass growth and carbon fixation in managed forests [in press]. *Data Br* 2019.
- [78] Colin A, Thivolle A. Disponibilités en bois d'origine forestière à l'horizon 2035. Tome 1: rapport. ADEME/IGN/FCBA. Paris: 2016.
- [79] Lorne D, Tchong-Ming S. The French biofuels mandates under cost uncertainty – an assessment based on robust optimization. *Les Cah l'économie* 2012;33.
- [80] Edwards R, Lariv' J-F, Richeard D, Weinhof W. Well-to-Tank Report" Version 4.a: JEC Well-To-Wheels Analysis of Future Automotive Fuels and Powertrains in the European Context. Ispra: JRC-Joint Research Centre: 2014. doi:10.2790/95629.

- [81] WBCSD, WRI. Greenhouse Gas Protocol: Product Life Cycle Accounting and Reporting Standard. 2011.
- [82] IPCC. Chapter 4. Agriculture, forestry and other land use. In: Eggleston S, Buendia L, Miwa K, Ngara T, Tanabe K, editors. 2006 IPCC Guidel. Natl. Greenh. Gas Invent., Intergovernmental Panel on Climate Change, Prepared by the National Greenhouse Gas Inventories Programme; 2006.
- [83] EC-JRC. ILCD Handbook: Recommendations for life cycle impact assessment in the European context. Institute for Environment and Sustainability: International Reference Life Cycle Data System. EUR 24571 EN. Publications Office of the European Union. Luxemburg: 2011. doi:10.278/33030.
- [84] Pretzsch H. Forest Dynamics, Growth and Yield- From Measurement to Model. Berlin Heidelberg: Springer-Verlag; 2009. doi:10.1007/978-3-540-88307-4.
- [85] INRA/ONF/ENGREF. Tables de production pour les forêts françaises. 2e édition. Nancy: INRA-Centre National de Recherche Forestières, ONF- Office National des Forêts, ENGREF- Ecole Nationale du Génie rural, des Eaix et des Forêts; 1984.
- [86] Menéndez-Miguélez M, Álvarez-álvarez P, Majada J, Canga E. Management tools for *Castanea sativa* coppice stands in northwestern Spain [Spanish: Herramientas de gestión para masas de monte bajo de *Castanea sativa* en el noroeste de España]. *Bosque* 2016;37:119–33. doi:10.4067/S0717-92002016000100012.
- [87] Shvidenko A, Schepaschenko D, Nilsson S, Boului Y. Federal Agency of Forest Management International Institute for Applied Systems Analysis Tables and Models of Growth and Productivity of Forests of Major Forest Forming Species of Northern Eurasia (standard and reference materials). Moscow: 2008.
- [88] Zhang L. Cross-validation of non-linear growth functions for modelling tree height-diameter relationships. *Ann Bot* 1997;79:251–7. doi:10.1006/anbo.1996.0334.
- [89] Pommerening A, Muszta A. Relative plant growth revisited: Towards a mathematical standardisation of separate approaches. *Ecol Modell* 2016;320:383–92. doi:10.1016/j.ecolmodel.2015.10.015.
- [90] Zhao-gang L, Feng-ri L. The generalized Chapman-Richards function and applications to tree and stand growth. *J For Res* 2003;14:19–26. doi:10.1007/BF02856757.
- [91] Fekedulegn D, Mac Siurtain MP, Colbert JJ. Parameter estimation of nonlinear growth models in forestry. *Silva Fenn* 1999;33:327–36. doi:10.14214/sf.653.
- [92] IGN. Le mémento inventaire forestier édition 2017. IGN-Institut Natl l’information Géographique For 2017;2017:30. https://inventaire-forestier.ign.fr/IMG/pdf/memento_2017.pdf (accessed July 20, 2018).
- [93] Levasseur A, Lesage P, Margni M, Brandão M, Samson R. Assessing temporary carbon sequestration and storage projects through land use, land-use change and forestry: comparison of dynamic life cycle assessment with ton-year approaches. *Clim Change* 2012. doi:10.1007/s10584-012-0473-x.

- [94] Vogtländer JG, Van Der Velden NM, Van Der Lugt P. Carbon sequestration in LCA, a proposal for a new approach based on the global carbon cycle: Cases on wood and on bamboo. *Int J Life Cycle Assess* 2014;19:13–23. doi:10.1007/s11367-013-0629-6.
- [95] Zetterberg L, Chen D. The time aspect of bioenergy - climate impacts of solid biofuels due to carbon dynamics. *GCB Bioenergy* 2015;7:785–96. doi:10.1111/gcbb.12174.
- [96] Demertzi M, Paulo JA, Faias SP, Arroja L, Dias AC. Evaluating the carbon footprint of the cork sector with a dynamic approach including biogenic carbon flows. *Int J Life Cycle Assess* 2018;23:1448–59. doi:10.1007/s11367-017-1406-8.
- [97] Fouquet M, Levasseur A, Margni M, Lebert A, Lasvaux S, Souyri B, et al. Methodological challenges and developments in LCA of low energy buildings: Application to biogenic carbon and global warming assessment. *Build Environ* 2015;90:51–9. doi:10.1016/j.buildenv.2015.03.022.
- [98] Lindeijer E, Müller-Wenk R, Bengt S. Impact Assessment of Resources and Land Use. In: de Haes HAU, Finnveden G, Goedkoop M, Hauschild, Michael, Hertwich EG, Hofstetter P, et al., editors. *Life-Cycle Impact Assess. Striving Toward Best Pract.*, Society of Environmental Toxicology and Chemistry (SETAC); 2002, p. 11–64.
- [99] Choudhary S, Liang S, Cai H, Keoleian GA, Miller SA, Kelly J, et al. Reference and functional unit can change bioenergy pathway choices. *Int J Life Cycle Assess* 2014;19:796–805. doi:10.1007/s11367-013-0692-z.
- [100] Cherubini F, Bird ND, Cowie A, Jungmeier G, Schlamadinger B, Woess-Gallasch S. Energy- and greenhouse gas-based LCA of biofuel and bioenergy systems: Key issues, ranges and recommendations. *Resour Conserv Recycl* 2009;53:434–47. doi:10.1016/j.resconrec.2009.03.013.
- [101] UNFCCC. Draft A/R Methodological tool “Estimation of emissions from clearing, burning and decay of existing vegetation due to implementation of a CDM A/R project activity” (Version 01). New York: 2009.
- [102] Cornillier C, Benoist A. Etude préliminaire à la réalisation de bilans environnementaux sur le chauffage au bois – Partie 2 : Mise en œuvre de méthodes de caractérisation d’impact sur le changement climatique. ADEME-Agence de l’environnement et de La Maîtrise de l’énergie. Paris: 2015.
- [103] Brunet-Navarro P, Jochheim H, Muys B. Modelling carbon stocks and fluxes in the wood product sector: a comparative review. *Glob Chang Biol* 2016;22:2555–69. doi:10.1111/gcb.13235.
- [104] Montes F, Cañellas I. Modelling coarse woody debris dynamics in even-aged Scots pine forests. *For Ecol Manage* 2006;221:220–32. doi:10.1016/j.foreco.2005.10.019.
- [105] Ros JPM, van Minnen JG, Arets EJMM. Climate effects of wood used for bioenergy. PBL Netherlands Environmental Assessment Agency. The The Hague. Doi 10.1002/Bbb.1407: 2013. doi:10.1002/bbb.1407.

- [106] Levasseur A, Cavalett O, Fuglestvedt JS, Gasser T, Johansson DJA, Jørgensen S V., et al. Enhancing life cycle impact assessment from climate science: Review of recent findings and recommendations for application to LCA. *Ecol Indic* 2016;71:163–74. doi:10.1016/j.ecolind.2016.06.049.
- [107] Levasseur A, Lesage P, Margni M, Samson R. Biogenic Carbon and Temporary Storage Addressed with Dynamic Life Cycle Assessment. *J Ind Ecol* 2012;17:117–28. doi:10.1111/j.1530-9290.2012.00503.x.
- [108] Guest G, Cherubini F, Strømman AH. Global Warming Potential of Carbon Dioxide Emissions from Biomass Stored in the Anthroposphere and Used for Bioenergy at End of Life. *J Ind Ecol* 2012;17. doi:10.1111/j.1530-9290.2012.00507.x.
- [109] Holtmark B. Boreal forest management and its effect on atmospheric CO₂. *Ecol Modell* 2013;248:130–4. doi:10.1016/j.ecolmodel.2012.10.006.
- [110] EC. EU Climate Action: Climate strategies & targets. Eur Comm Platf 2018. https://ec.europa.eu/clima/policies/strategies_en (accessed February 7, 2018).
- [111] Carpenter B, Gelman A, Hoffman MD, Lee D, Goodrich B, Betancourt M, et al. Stan: A Probabilistic Programming Language. *J Stat Softw* 2017;76. doi:10.18637/jss.v076.i01.
- [112] Edwards MR, Trancik JE. Climate impacts of energy technologies depend on emissions timing. *Nat Clim Chang* 2014;4:347–52. doi:10.1038/nclimate2204.
- [113] Pommerening A. Arne Pommerening's Webblog on Forest Biometrics. Swedish Univ Agric Sci 2017. <https://blogg.slu.se/forest-biometrics/2017/03/11/the-chapman-richards-growth-function/> (accessed November 15, 2017).
- [114] Cherubini F, Bright RM, Strømman AH. Site-specific global warming potentials of biogenic CO₂ for bioenergy: contributions from carbon fluxes and albedo dynamics. *Environ Res Lett* 2012;045902. doi:10.1088/1748-9326/7/4/045902.
- [115] Newell JP, Vos RO. Accounting for forest carbon pool dynamics in product carbon footprints: Challenges and opportunities. *Environ Impact Assess Rev* 2012;37:23–36. doi:10.1016/j.eiar.2012.03.005.
- [116] Berndes G, Ahlgren S, Börjesson P, Cowie AL. Bioenergy and land use change — state of the art. *WIREs Energy Env* 2013;2:282–303. doi:10.1002/wene.41.
- [117] De Rosa M, Knudsen MT, Hermansen JE. A comparison of Land Use Change models: Challenges and future developments. *J Clean Prod* 2015;113:183–93. doi:10.1016/j.jclepro.2015.11.097.
- [118] Brandão M, Clift R, Cowie A, Greenhalgh S. The Use of Life Cycle Assessment in the Support of Robust (Climate) Policy Making: Comment on “Using Attributional Life Cycle Assessment to Estimate Climate-Change Mitigation.” *J Ind Ecol* 2014;18:461–3. doi:10.1111/jiec.12152.

4.3 Paper 2: Chicken-egg dilemma in the context forest carbon accounting

This paper contrasts the historic and future time perspectives of dynamic C_{bio} sequestration and discusses the modelling choice, to be published in the International Journal of Life Cycle Assessment (DOI: [10.1007/s11367-019-01695-7](https://doi.org/10.1007/s11367-019-01695-7)), received 14 February 2019, accepted 23 September 2019].

Objective	Assess the chicken-egg dilemma (opposed modelling time perspectives) linked with the timing of forest-related C_{bio} sequestration, to: <ul style="list-style-type: none">• Identify the implications on the system boundaries• Evaluate the effects on the final dynamic results• Compare to biomass reference scenarios (“no use”)• Propose generalised rules for choosing a time perspective
Approach	Application of the same coupling strategy of Paper 2 to assess prospective forest wood consumption
Sector (product)	Energy-mix and Transport (bioenergy)
Biomass	Forest wood residues
Supporting data	Data Paper on C_{bio} growth and sequestration dynamic Appendix D: Data paper on forest models Paper 1 in section 4.2: Model coupling strategy

Back to the future: Dynamic full carbon accounting applied to prospective bioenergy scenarios

Ariane Albers ^{1,2,3,*}, Pierre Collet ¹, Anthony Benoist ^{3,4}, Arnaud Hélias ^{2,3,5}

¹ IFP Energies nouvelles, 1 et 4 Avenue de Bois-Préau, 92852 Rueil-Malmaison, France

² LBE, Montpellier SupAgro, INRA, UNIV Montpellier, Narbonne, France

³ Elsa, Research group for Environmental Lifecycle and Sustainability Assessment, Montpellier, France

⁴ CIRAD - UPR BioWooEB, Avenue Agropolis, F-34398 Montpellier, France

⁵ Chair of Sustainable Engineering, Technische Universität Berlin, Berlin, Germany

* Corresponding author

Abstract

Purpose: Ongoing debates focus on the role of forest-sourced bioenergy within climate mitigation efforts, due to the long rotation lengths of forest biomass. Valuing sequestration is debated due to its reversibility; however, dynamic modelling of biogenic carbon (C_{bio}) flows captures both negative and positive emissions. The objective of this work is to respond to the key issue of timing sequestration associated with two opposed modelling choices (historic vs. future) in the context of dynamic life cycle assessment (LCA).

Methods: The outputs of a partial-equilibrium model are used to inform prospective evaluations of the use of forest wood residues in response to an energy transition policy. Dynamic forest carbon modelling represents the carbon cycle between the atmosphere and technosphere: C_{bio} fixation and release through combustion and/or decay. Time-dependent characterization is used to assess the time-sensitive climate change effects. The two C_{bio} sequestration perspectives for bioenergy (forest biomass use) and reference (no use) scenarios are contrasted to assess (i) their temporal profiles, (ii) their climatic consequences concerning C_{complete} (fossil + biogenic C) vs. C_{neutral} (fossil C) approaches, and (iii) the implications of comparing the two approaches with dynamic LCA.

Results and discussion: Full lifetime carbon accounting confirms that C_{bio} entering the bioenergy system equals the C_{bio} leaving it in the net balance, but not within annual dynamic balances, which alter the atmospheric greenhouse gas composition. The impacts of the historic approach differed considerably from those of the future. Moreover, the “no use” scenario yielded higher forcing effects than the “bioenergy” due to the higher methane proportions. The chickenegg dilemma arises in attributional LCA: as the forcing depends on the timing of the C_{bio} sequestration and its allocation to a harvest activity. A decision tree supported by case study applications provides general rules for selecting the adequate time-related modelling approach based on the criteria of provision of wood and regrowth from managed and unmanaged forests, determined by the origin of biotic resources and related spheres.

Conclusions: Excluding dynamic C_{bio} introduces under- (future) or over- (historic) estimation of the results, misleading mitigation decisions. Further research is needed to close the gap between forest stand and landscape level, addressing issues beyond the chicken-egg dilemma and developing complete dynamic LCA studies.

Keywords: bioenergy; biogenic carbon; carbon sequestration; climate change; dynamic LCA

List of acronyms

C	Carbon	GHG	Greenhouse Gas
C _{bio}	Biogenic carbon	LTECV	French Energy Transition for Green Growth Act
CDM	Clean Development Mechanism	LULUCF	Land Use, Land Use Change and Forestry
CER	Certified Emission Reduction	N ₂ O	Nitrous Oxide
CFs	Characterisation Factors	PEM	Partial-equilibrium model
CH ₄	Methane	RF	Radiative Forcing
CO ₂	Carbon dioxide	TH	Time Horizon
CO ₂ -eq	Carbon Dioxide Equivalent	TIMES	The Integrated Markal-Efom System
EOL	End-of-life	UNFCCC	United Nations Framework Convention on Climate Change
FoWooR	Forest Wood Residues		

1 Introduction

1.1 Carbon accounting

The growing demand for alternative renewable energy carriers, to support a transition towards low carbon economies, has been supported since the 90s under the Kyoto Protocol, by international mechanisms such as the Clean Development Mechanism (CDM) and Certified Emission Reduction (CER) (UNFCCC 2019), as well as by EU legislation setting ambitious targets to reduce greenhouse gas (GHG) emissions (EC 2009; Scarlat et al. 2015). Incentives encourage the displacement of fossil carbon by means of biogenic carbon (C_{bio}), thus crediting (e.g. carbon offsets) the avoided equivalent fossil sourced emission.

Carbon flows are differentiated by their source of origin, as fossil from non-renewable and biogenic from renewable biomass sources. Alternative bioenergy pathways based on dedicated and residual lignocellulosic biomass (e.g. forest wood, short rotation coppice, maize stover, wheat straw, perennial grasses) are increasingly recognised as competitive advanced substitutes to displace fossil carbon and reduce the use of first generation energy crops, a desirable evolution under land-use and food security concerns (Wise et al. 2009; Rathmann et al. 2010; Harvey and Pilgrim 2011).

Ongoing debates focus on the role of forest-based bioenergy within the climate mitigation efforts, due to its long rotation lengths and thus long sequestration periods (Haberl et al. 2012; Cowie et al. 2013a). Despite the end-of-life (EOL) of biomass as biofuel combustion or wood incineration represents an instant release, the timing of C_{bio} sequestration in biomass may stretch over several decades (Zetterberg and Chen 2015). Yet, valuing temporary carbon sequestration (carbon removal from the atmosphere and fixation in the biomass through photosynthesis) and storage (carbon retention in the technosphere) for bioenergy systems has long been questioned (Levasseur et al. 2012a; Brandão et al. 2013).

The Life Cycle Assessment (LCA) framework allows for a holistic assessment of potential climate change impacts (and other environmental impacts) of bioenergy systems, but conventionally from a static perspective (Guinée et al. 2002). Originally, temporal information is not processed by the computational structure of LCA (Heijungs and Suh 2002) and is excluded from the ISO standard (ISO 2006a, b). The global warming potential (GWP) method represents a relative measure of the sum of all inventoried instant to long-term GHG emissions fixed over a time horizon (TH), regardless of when in time the emissions occur (Benoist 2009; Levasseur et al. 2010). This static quality concerns also the C_{bio} flows, often excluded from life cycle inventories (LCI) (Pawelzik et al. 2013). The conventional LCA approach is restricted to linear simplification and thus an inherent carbon neutrality (i.e. one unit of C_{bio} release is balanced through the same unit of C_{bio} sequestered) is associated with the use of any type of biomass. Two main approaches for biomass-sourced products are well discussed in LCA literature, namely carbon neutral and carbon storage (Pawelzik et al. 2013), respectively applied to short-lived (bioenergy) and long-lived (e.g. wood construction materials) products. For bioenergy systems, the widely used carbon neutral approach is based on the abovementioned steady state assumption.

The carbon neutral (C-neutral) approach excludes C_{bio} emissions from bioenergy with EOL modelled as combustion/ incineration, but includes fossil emissions for biofuel production (Johnson 2009; Agostini et al. 2014; Wiloso et al. 2016). Nonetheless, for forestry resources it has long been criticised as an erroneous accounting approach (Searchinger et al. 2009; Haberl et al. 2012), because “closing the biogenic carbon cycle” (Zetterberg and Chen 2015) does not necessarily mean CO_2 neutral. Given the generalised C-neutral assumption, conventional LCA approaches disregard the temporal effects from sequestration in forestry systems, thus failing at linking both bioenergy and forest carbon modelling (Searchinger et al. 2009; Newell and Vos 2012; Røyne et al. 2016). From a national viewpoint, forest C_{bio} flows are ignored downstream (bioenergy combustion), as the C losses are accounted for at the upstream (i.e. land use, land use change and forestry - LULUCF) by means of the stock change method for global carbon pools used in national GHG inventory reports (IPCC 2006a; UNFCCC 2014). That is to say, emissions reported at the LULUCF are not reported in the bioenergy sector, to avoid double counting (Zanchi et al. 2010). For instance, CO_2 emissions from biofuels are excluded from the EU Emission Trading System (Zetterberg and Chen 2015).

The temporary carbon storage approach, on the other hand, is optional for long-lived bioproducts (e.g. wood construction material), providing a benefit to delayed emissions from C_{bio} embedded in biomaterials. The ILCD Handbook (EC-JRC 2010) and the PAS2050 (BSI 2008) standard allow the accounting of emission delays over 100 years (i.e. postponement of radiative forcing - RF). Long-term storage beyond one century is not accounted for, but reported separately. The tonne-year-based Moura-Costa (Moura

Costa and Wilson 2000) and Lashof (Fearnside et al. 2000) approaches, initially introduced in the context of LULUCF, have been discussed for product level applications (Korhonen et al. 2002; Levasseur et al. 2012b).

An alternative dynamic approach has been proposed in the context of the dynamic LCA method (Levasseur et al. 2010), featuring time-sensitive climate change impacts via the timing of fossil and biogenic flows. The timing difference of C_{bio} flows between sequestration and release, from and to the atmosphere, defines the period over which the carbon is embedded in the technosphere. During that period, the RF is postponed (for biomass resources with long rotation lengths and long-lived products) or eventually avoided through permanent stocks (Christensen et al. 2009; Vogtländer et al. 2014). The dynamic method was contrasted with the tonne-year approaches (Levasseur et al. 2012b) as well as with the GWP metric and other methods from the ILCD Handbook and PAS2050, used in classical LCA, showing significant variations in the results (Levasseur et al. 2012c).

1.2 Dynamic approaches for timing biogenic carbon

Available methods, including the dynamic one, have been thoroughly discussed for valuing temporary carbon sequestration and storage for LCA bioenergy (Brandão et al. 2013, 2019), yet it was concluded that none of the current methods is preferred over the other, as the results still depend on a time horizon (TH) for the characterisation. Nonetheless, a few methodology reports, such as the CML Handbook (Guinée et al. 2002), the ReCiPe methodology (Hischier et al. 2010) and the FAO EX-ACT tool (Grewer et al. 2017)—described and compared with other carbon modelling tools in Colomb et al. (2012)—discussed the importance of accounting for CO_2 of biogenic origin in specific studies.

The dynamic LCA method appears to be adequate, tackling the issue of timing biogenic elementary flows, as applied in several other studies of forest bioproducts (Fouquet et al. 2015; Daystar et al. 2016; Peñaloza et al. 2016, 2018; Demertzi et al. 2018), and more specifically of forest-bioenergy (Zetterberg and Chen 2015; Albers et al. 2019a). As highlighted by Levasseur et al. (2012c), none of the current carbon accounting methods consider the temporal profiles of C_{bio} flows.

Temporary carbon storage is diluted by subtracting the amount of sequestered carbon from the emissions occurring at the end of the storage period, thus yielding a net zero emission. In contrast, carbon storage is reversible (i.e. reemitted) at some point in time, making it highly debatable whether or not assigning a value to it is justifiable (Levasseur et al. 2012a; Brandão et al. 2013). Yet, the dynamic method captures all the lifecycle emissions, including delays through time, by taking into account both the upstream (sequestration) and downstream (e.g. combustion/incineration, decay) flows.

1.3 Challenges of timing forest carbon sequestration

The application of a dynamic LCA requires temporal emission profiles, i.e. the development of dynamic inventories by timing each elementary flow (Collet et al. 2011). C_{bio} sequestration related with forest tree growth has been modelled, for instance, by means of a net carbon balance and linear distribution (Levasseur et al. 2012b), Gaussian normal distribution (Cherubini et al. 2011a; Cardellini et al. 2018), non-linear growth models such as the CARBINE model (De Rosa et al. 2017), the Schnute model (Cherubini et al. 2011b), or the Chapman-Richards model (Yan 2018; Albers et al. 2019a).

Whatever modelling approach applied, the dynamic C_{bio} sequestration flows face a key accounting challenge, the so-called “chicken-and-egg dilemma” (Levasseur et al. 2012c). It refers to an allocation issue to a harvest activity: the dynamic LCI can be modelled by considering a full biomass growth/rotation length before or after the harvest of said biomass. The former accounts for historic C_{bio} sequestration flows (forest growth occurs before logging) and the latter for future C_{bio} sequestration flows (forest re-regrowth occurs after logging by replanting new seedlings).

Published studies have applied the historic (Vogtländer et al. 2014; Zetterberg and Chen 2015; Demertzi et al. 2018; Albers et al. 2019a), future (Cherubini et al. 2011b, a; Levasseur et al. 2012b; Repo et al. 2015; Pingoud et al. 2016; De Rosa et al. 2017) and occasionally both (Levasseur et al. 2012c; Fouquet et al. 2015; Peñaloza et al. 2018) approaches. These opposed time perspectives yield different results, which require careful justification of the modelling choice. Future-oriented sequestration has been recommended for consequential LCA, and historic accounting for attributional LCA modelling (De Rosa et al. 2017). No universal guideline exists to date, on how to set the temporal boundaries of forest resource modelling or how to justify the use of one modelling approach over the other.

The objective of this study is thus to contrast both time-related modelling choices (before/historic vs. after/future) for C_{bio} sequestration of forestry resources related with prospective bioenergy scenarios, to better comprehend the time-sensitive climate change effects in the context of the dynamic LCA framework. Consequently, a detailed discussion is intended to deliver transparency and broaden understanding by exploring different cases, to support robust decision-making on the modelling choice.

2 Materials and methods

This study challenges the C neutral and static assumptions for forest biomass resources with long rotation lengths by timing both C_{bio} sequestration and release flows (dynamic C_{bio} balance). An illustrative case study was developed based on data from a partial-equilibrium model (PEM) for the entire energy-transport sector in France. The model-coupling principle, described in detail in Albers et al. (2019a), combines

prospective energy system analysis with C_{bio} models to assess the time-sensitive potential climatic consequences of any energy policy scenario by means of a fossil + biogenic (C-complete) accounting. It enables accounting and characterising time-dependent C_{bio} flows from emerging renewable energy pathways (i.e. biomass commodities) in the specific context of the dynamic LCA framework proposed by Levasseur et al. (2010).

Unlike classical LCA approaches, the functional unit expresses the national (here France) prospective energy demand, in GJ, per policy constraint and per year, over a given simulation period (here from 2019 to 2050), required to satisfy the energy consumption of end-users (industry, transport and households) across scenarios: the energy-mix (electricity and heat) and transport-biofuels (i.e. GJ per km travelled by a specific transportation means). The dynamic C_{bio} balance refers to the PEM functional unit by modelling the biogenic elementary flows, in $t C_{\text{bio}} \cdot \text{yr}^{-1}$, of the supply commodity output forest wood residue (hereafter referred to as FoWooR), a biomass-sourced energy carrier used as a renewable raw material.

The two C_{bio} sequestration time perspectives for FoWooR are assessed, by contrasting: i) the different temporal profiles, ii) their time-dependent climatic consequences computed by C-complete vs C-neutral approaches and iii) the implications of comparing the two approaches with dynamic LCA.

2.1 Data from a prospective partial-equilibrium model

LCA studies have previously been combined with PEM models to identify emerging technologies and energy pathways as well as to carry out consequential modelling in LCA implying changes in demand (Eriksson et al. 2007; Earles et al. 2013; Marvuglia et al. 2013; Vázquez-rowe et al. 2014; Menten et al. 2015a; Levasseur et al. 2017; Albers et al. 2019a).

PEM models are key instruments to support robust decision-making by assessing in detail substitution alternatives and potential future energy pathways and their consequences on the market dynamic on specific sub-sectors (from the supply-and demand-side) and the environment (Gargiulo and Brian 2013; Nicolas et al. 2014). A commonly used PEM model generator is TIMES (MARKet Allocation-EFOM System; <https://iea-etsap.org/>). The model framework explores bottom-up linear optimisation pathways with a detailed technology database linking petroleum and biomass commodities with diverse conventional and refinery and innovative biomass conversion processes (Loulou et al. 2016).

We used the PEM model TIMES-MIRET, analysing the energy-mix (electricity and heat network) and transport sectors of metropolitan France (Lorne and Tchong-Ming 2012), following Albers et al. (2019a), to obtain prospective scenarios on the FoWooR commodity supply and the net GHG emissions (here

fossil-sourced CO₂ and N₂O) of the entire energy-transport system assessed (detailed in the Supplementary Material).

The provision of energy services to end-users encompasses biomass and crude oil extraction, refinery and bioprocess, combustion at tailpipe, as well as heat and electricity network; including import-exports to/from other sectors. Besides conventional and renewable energy technologies, the TIMES-MIRET database contains emerging biomass conversion processes for second and third generation biofuels. Advanced biofuels from FoWooR, for instance, involve biochemical (ethanol) or thermo-chemical (synthetic/Fisher-Tropsch diesel) processes, depending on scenario simulations. Process pathways for other lignocellulosic biomass or algae involve transesterification or hydro treated pyrolysis oil.

TIMES-MIRET is calibrated to a reference policy scenario based on the 2009/28/EC Directive and National Renewable Energy Action Plan, as the business-as-usual (BAU) policy scenario. The policy scenario assessed in this study is based on the multi-annual energy programming of the 2015 French Energy Transition for Green Growth Act (MTES 2017) – referred here as LTECV scenario. The LTECV scenario contains all constraints from BAU, including the updated targets for the transport sector: by 2030 minimum 15% renewable energy share and 30% reduction of fossil fuels, from 2020 maximum 7% share of first generation biofuels, and intermediate targets from 2018-2023 for advanced biofuels.

2.2 Biogenic carbon modelling: full lifetime accounting

The dynamic C_{bio} balance represents the cycling carbon between the atmosphere and technosphere: C_{bio} fixation into the biomass through photosynthesis and the C_{bio} release through combustion and/or decay. C_{bio} fixation and C_{bio} decay gradually extend over longer periods, while C_{bio} combustion represents instant release emissions.

The C_{bio} fixation dynamic is computed by means of the forest carbon modelling approach of all main tree species of the wood supply chain in France, following Albers et al. (2019a), to predict the annual C_{bio} fixation from the atmosphere [t C_{bio}·yr⁻¹] over a given rotation length (provided in the Supplementary Material). The C_{bio} model refers to non-linear mean forest tree growth (Fekedulegn et al. 1999; Pretzsch 2009; Pommerening and Muszta 2015) based on the Chapman Richards model (Richards 1959) and allometric relations (Henry et al. 2013), including operationalised yield tables from long-term experimental forest plots (INRA/ONF/ENGREF 1984), featuring management regimes (e.g. thinning periods, rotation lengths and number of trees per plot). The growth, is characterised by a diminishing rate of C_{bio} sequestration as the tree matures, represented by a (classical) asymptotic and sigmoid growth curve. The modelling is based on homogenous growth of un-even aged and mixed management practices

Chapter 4: Forestry: growth modelling

per forest stand. A key choice affecting the C_{bio} sequestration model concerns the data and models used to compute fixation (e.g. level of local-specificity of data used to fit the growth models, etc.), as well as the computation of the timing of sequestration.

C_{bio} decay dynamic is computed by a simple negative exponential equation, described in Albers et al. (2019a). CH_4 emissions are estimated at 1.5% and 10%, respectively, for coarse woody debris and roots (Ros et al. 2013). The half-life decay values for aboveground and belowground are assumed at 8 and 30 years respectively (Montes and Cañellas 2006).

This study covers all FoWooR commodity outputs described in the TIMES-MIRET LTECV scenario, deriving from logging and thinning operations of commercial forests in France and collected for bioenergy use (i.e. cogeneration and transport biofuels). Additionally, a reference scenario is defined, against which the bioenergy is compared to evaluate potential climate change mitigation. According with Cowie et al. (2013), the reference may include forest management (e.g. for a different mix of products and services, or for conservation), but should exclude bioenergy. The C_{bio} reference in this study is referred to as “no use” of FoWooR for bioenergy, which implies 100% of FoWooR left behind in the forest floor and emitted as CO_2 and CH_4 , from both aerobic and anaerobic degradation.

Fig. 1 shows a full lifetime accounting of C_{bio} flows (fixation and releases), under two scenarios concerning bioenergy and the no use (reference) scenarios of the commodity. In the bioenergy scenario, 30% of FoWooR are accounted as non-collectable left behind biomass (Cacot et al. 2006; Lippke et al. 2011) and the collected portion (70% of logging residues) is further processed into advanced biofuels and electricity-heat cogeneration. The biofuel combustion is assumed to be emitted as CO_2 , while the C_{bio} decay releases from non-collectable/left-behind wood as CO_2 and CH_4 (to 30% in the bioenergy and to 100% in the no use scenarios). The C_{bio} flows from the belowground biomass corresponding to FoWooR are included by mass allocation of the residual part (37%) to the belowground root part (20%), resulting in 7.4% (Albers et al. 2019a).

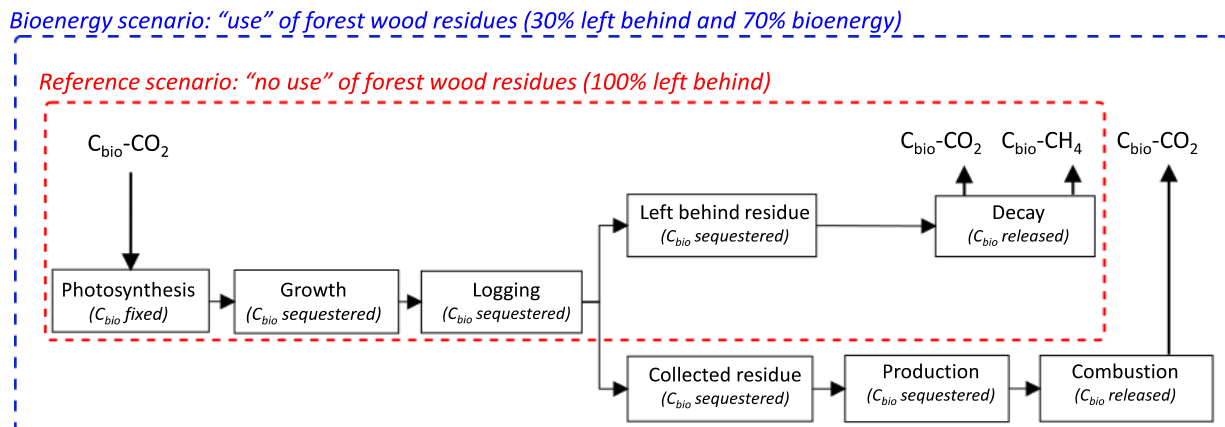

Fig. 1. Full lifetime accounting of biogenic carbon (C_{bio}) from forest wood residues includes fixation, sequestration and end-of-life releases through decay and/or combustion. The system boundary features two scenarios, the bioenergy (70% of logging residues are combusted and 30% left behind to decay) and the reference “no use” (all residues are left in the forest floor to decay)

2.3 Temporal boundaries in dynamic LCA

Defining the temporal boundaries is as a key issue when describing the emission flows through time, particularly concerning C_{bio} from forestry resources (Levasseur et al. 2012b; Peñaloza et al. 2018). The LCA ISO 14040/14044 standard (ISO 2006a, b) refers to the setting of a time horizon (TH) for the impact characterisation (e.g. in the climate change category) in the goal and scope phase, but excludes any specification on the temporal emission profiles (i.e. temporally-differentiated LCI) of the modelled system.

Dynamic LCA implies defining a study TH, to establish the timing of the emission flows and impact representations in the characterisation, by specifying: i) an inventory TH (hereafter referred to as LCI TH), and ii) an impact assessment TH (hereafter referred to as LCIA TH). The LCI TH describes when in time negative (C_{bio} sequestration) and positive (fossil and C_{bio} releases) flows occur over which the dynamic inventories are built. The LCIA TH is variable for time-dependent characterisation factors (CFs), when the evolution of the RF is evaluated and observed over time. By setting a specific end-year to the LCIA TH—a so called a “fixed future reference year” (Levasseur et al. 2016)—a temporal cut-off is performed, which is an unavoidable for comparison purposes and capturing the C_{bio} benefits (temporary sequestration) or impacts.

2.3.1 The dynamic inventory time horizon: Timing biogenic and fossil carbon emissions

When coupling with any demand model, in this study with the PEM TIMES-MIRET, all C_{bio} emissions are aligned with the model's simulation years. The first carbon release represents t_0 , starting with the first combustion release (i.e. 2019) and ending with last year at t_{31} (i.e. 2050) of the PEM simulation.

All negative emissions from sequestration are adapted to the PEM simulation period going backwards or forward in time, depending on modelling approach applied. The historic approach allocate a full rotation length before the final harvest (preceding the wood harvest: first forest growth then tree felling) and the latter after (following the harvest: tree felling first then seeding new trees). The applied forest carbon model by Albers et al. (2019b) describes a maximum 200-year rotation length. Each PEM simulation year, within the range of t_0 - t_{31} , represents a new harvest activity with its own sequestration curve. The total sequestration length for both historic and future perspectives sums up to 231 years, as shown in Fig. 2.

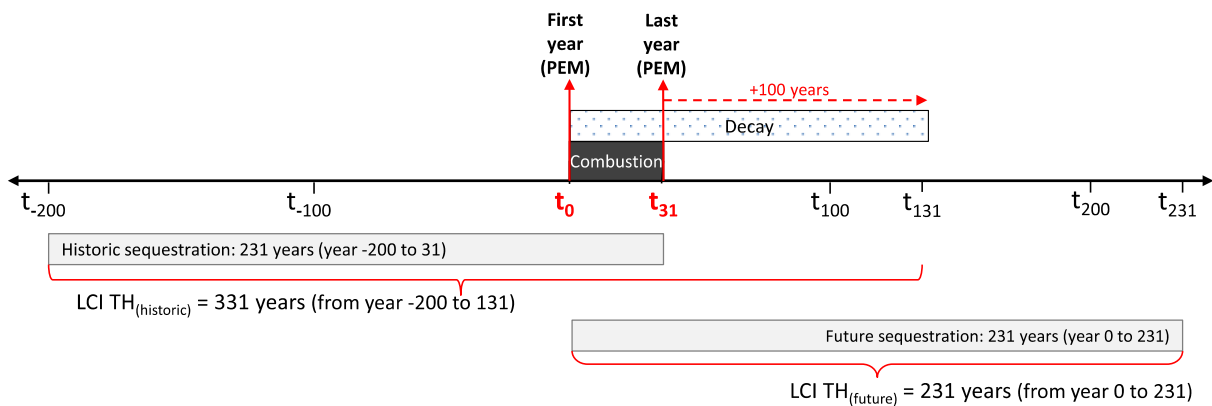

Fig. 2. Defining the time horizon of dynamic life cycle inventories concerning two opposed modelling time perspectives for biogenic sequestration

All positive biogenic and fossil releases from combustion (e.g. cogeneration or tail pipe) are instant, occurring within the same harvesting years over the range 0 to 31 years, while wood decay are long-term emissions distributed over several years, similar to C_{bio} sequestration. Under given half-life assumptions (see section 2.2) at least 60 years are required for the C_{bio} belowground biomass to decay. To avoid temporal cut-offs from long-term C_{bio} releases, it is recommended to extend the LCI TH, for instance, by adding 100 years to the last C_{bio} release (Fig. 2). Under such considerations, the net C_{bio} balance generates different LCI TH for historic and future time perspectives with 331 and 231 years respectively. Note that the 100-year TH is arbitrary, referring to the commonly reported TH in the IPCC Guidelines for National GHG Inventories (IPCC 2006b), following a political (e.g. UNFCCC Kyoto Protocol: CDM or CER

projects) rather than a scientific decision (Fearnside 2002; Shine et al. 2005). For a full lifetime carbon accounting a generic approach is thus proposed by means of Eq. 1 for the historic and Eq. 2 for future sequestration.

$$LCI TH_{historic} = Rotation\ length + [Year\ of\ last\ carbon\ release + 100\ years] \quad Eq. 1$$

$$LCI TH_{future} = \begin{cases} Year\ of\ last\ carbon\ release + 100\ years & ,\ if\ rotation\ length < 100 \\ Year\ of\ last\ carbon\ release + Rotation\ length & ,\ if\ rotation\ length \geq 100 \end{cases} \quad Eq. 2$$

2.3.2 The dynamic impact assessment time horizon: setting a reference end-year

The static method by means of the IPCC GWP metric (IPCC 2013) is not considered appropriate for dynamic carbon modelling, due to the fixed LCIA TH of 20 or 100 years. It assigns the same impact characterisation to all emissions, thus disregarding: i) the emission timing of each GHG emission in the atmosphere, ii) impacts beyond the fixed TH, providing a time preference to impacts (e.g. climate tipping points vs buying time for innovation), and iii) the inconsistency between LCI TH and LCIA TH; as confirmed by several authors (Kendall et al. 2009; O'Hare M. et al. 2009; Levasseur et al. 2010, 2016; Jørgensen and Hauschild 2013; Cherubini et al. 2016).

On the other hand, the time-dependent CFs by Levasseur et al. (2010) are variable, with no fixed TH, representing the actual impacts for any given characterisation TH. The method assesses each emission flow following the year of its fixation or release. It overcomes the inconsistency between the different THs generated by the different emission years, thus enabling a consistent assessment between LCI TH and LCIA TH. Yet, the dynamic characterisation does imply setting an end-year to the impact assessment to account for the C_{bio} sequestration benefits and allow transparent comparability among different scenarios. The end-year of the impact assessment would thus express the RF effects between the year of the emission release and the chosen fixed end-year (Levasseur et al. 2012c).

Consequently the study TH may cover ($LCIA\ TH > LCI\ TH$) or not ($LCIA\ TH < LCI\ TH$) all studied flows by the chosen end-year of the time-dependent characterisation, as exemplary shown in with the impulse-response function (Joos and Bruno 1996), predicting the decay of CO_2 in the atmosphere. It will state, whether all flows are accounted for (full lifetime accounting), and which are eventually excluded (cut-off) from the study. A temporal cut-off appears when an LCIA TH is set for 100 years (Fig. 3a), while the LCI TH accounts for 131 years. It is to remark that matching THs ($LCIA\ TH = LCI\ TH$) may not project the forcing effect of the last emission at year 131, requiring the LCIA TH to be larger than LCI TH, as shown in Fig. 3b. For the present study, we defined a matching study TH (i.e. $LCIA\ TH = LCI\ TH$) per C_{bio} sequestration time perspective.

(a) LCIA TH < LCI TH

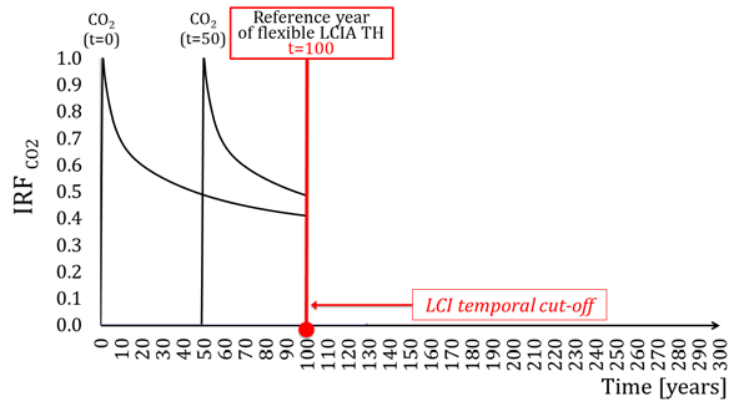

(b) LCIA TH > LCI TH

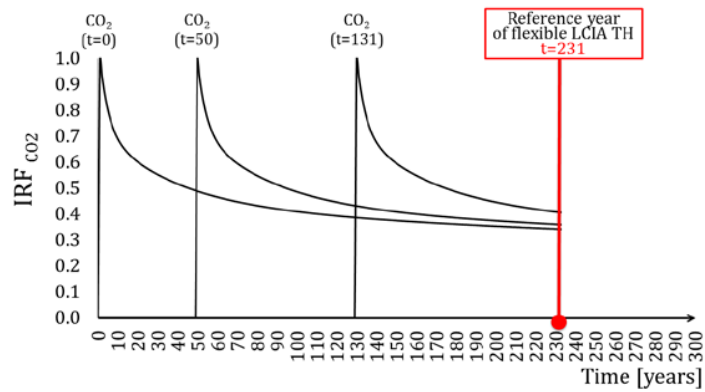

Fig. 3. Defining the study TH (temporal boundaries) by means of the life cycle inventory time horizon (LCI TH) and life cycle impact assessment time horizon (LCIA TH), illustrated with the impulse response function (IRF) of carbon dioxide (CO₂). The chosen LCIA TH may a) not cover or b) cover the elementary flows described within the LCI TH

3 Results

3.1 Dynamic inventory of biogenic carbon balance

Fig. 4 shows the C_{bio} balance of the FoWooR outputs from the LTECV policy scenario, contrasting both scenarios bioenergy and no use reference per historic and future modelling approach. The C_{bio} balance (darker shaded area in Fig. 4) consists of the sum of all negative and positive C_{bio} -CO₂ and C_{bio} -CH₄ flows (lighter shaded areas in Fig. 4) from C_{bio} fixation and release (combustion and/or decay). The C_{bio} flows are not yet converted into GHG emissions in this representation.

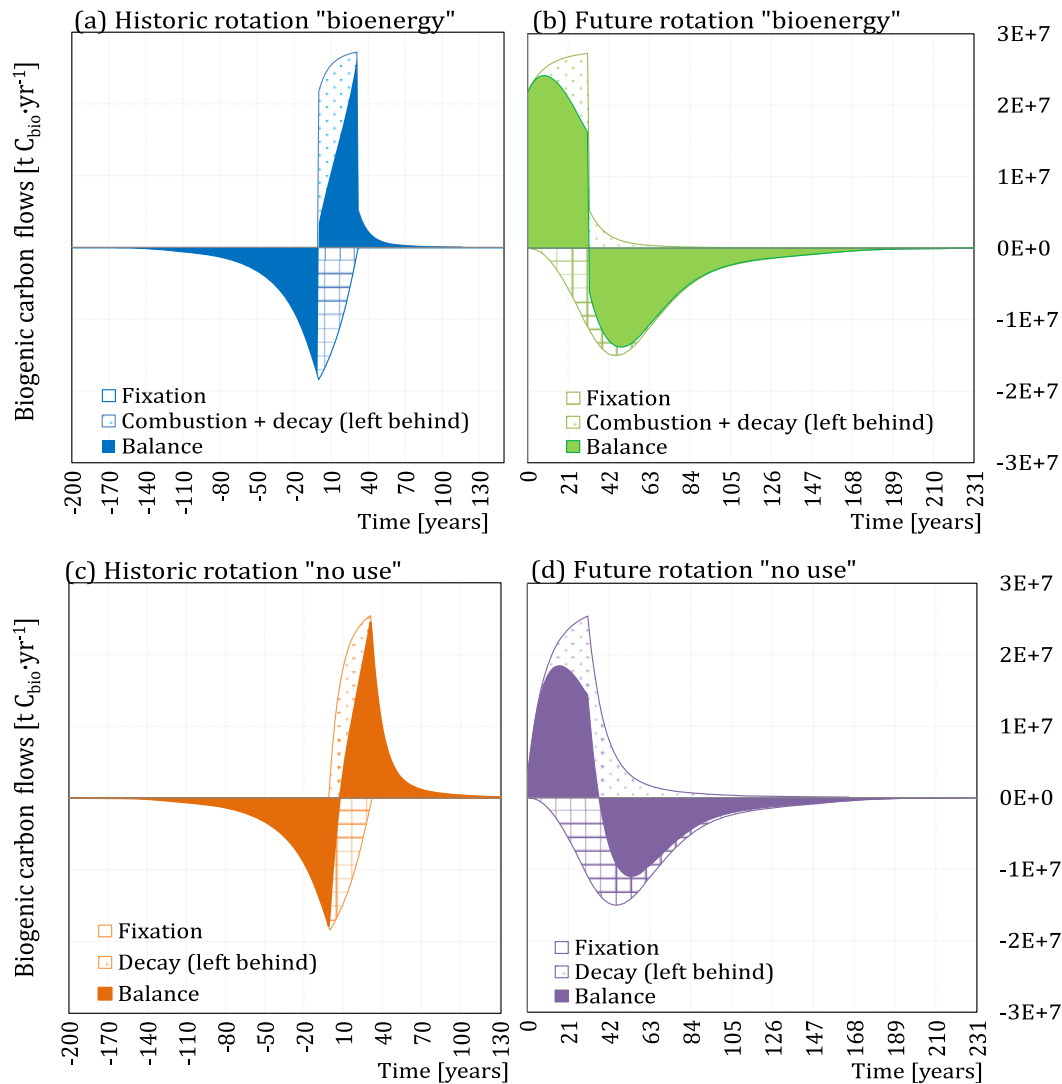

Fig. 4. Life cycle carbon flows from dynamic biogenic carbon (C_{bio}), in $t C_{bio} \cdot yr^{-1}$, accounting for forest wood residues under the “bioenergy” (a, b) and “no use” reference (c, d) scenarios per historic (a, c), and future (b, d) carbon sequestration time perspectives

The temporal profiles for bioenergy and reference scenarios have different LCI THs (see Fig. 2): for the historic 331 years (Fig. 4 a,c) and for the future 231 years (Fig. 4 b,d), representing the PEM simulations period 1819-2150 and 2019-2250, respectively. The described LCI THs cover close to 100% of all emissions in the C_{bio} balance (remaining $\pm 1E-3$ and $4E-5 t C_{bio}$, depending on the scenario). The C_{bio} balance thus represents a full lifetime carbon accounting with no inventory cut-offs, as all embedded C_{bio} in the FoWooR is released back to the atmosphere. The chosen LCI TH confirm that the amount of C_{bio} entering the system is equal to the amount of C_{bio} leaving the system, which means that C_{bio} emissions can

be considered neutral in the net balance, however not in the annual dynamic balance, ultimately affecting the atmospheric GHG composition.

3.2 Dynamic impact assessment of carbon flows

Fig. 5 shows the dynamic climate change impact assessment results of the LTECV policy per historic and future time perspectives, featuring C-neutral (fossil-sourced CO₂ and N₂O outputs from TIMES-MIRET), C-biogenic (C_{bio} balance) and C-complete (fossil + biogenic-sourced) curves for both bioenergy and no use FoWooR scenarios. Prior to the dynamic impact assessment all C_{bio}-CO₂ and C_{bio}-CH₄ flows were converted into the respective CO₂ and CH₄ GHG emissions, according to C-content in the molecules, 44/12 g CO₂ g C⁻¹ and 16/12 g CH₄ g C⁻¹ respectively. The instantaneous RF, in Fig. 5a,d describes the external net change in energy flows per watts square meter at the tropopause [$W \cdot m^{-2}$], while the integral is given as cumulative RF [$W \cdot yr \cdot m^{-2}$] in Fig. 5b,e and their relativisation to the cumulative CO₂ as the relative RF [t CO₂-eq] in Fig. 5c,f. Note that the impact representation of the two opposed modelling approaches have different t0 with different absolute calendar years of the PEM (i.e. 1819 for the historic and 2019 for the future approach).

The results of the C-biogenic flows per scenario and time perspective differ considerably. For the bioenergy scenario, the historic approach never fully reached positive, while the future approach never reached negative forcing effects. For the future approach, the instant and gradual releases from combustion and decay start simultaneously with the sequestration flows. The re-sequestration time of the emitted emissions is slow at the beginning and takes over two centuries (full rotation length) to compensate for the positive C_{bio} releases. For the historic approach, one full sequestration cycle is accounted before the first positive emission. Yet, the difference between the C_{bio} fixation and release curves decrease with increasing LCIA TH. Consequently, the further into the future the end-year of the impact assessment is set, the less significant do climatic benefits from C_{bio} sequestration become. Analogously, as demonstrated in the sensitivity analysis in Albers et al. (2019a), the shorter the rotation length of C_{bio} sequestration, the less significant are the negative forcing effects from C_{bio}.

The accounting of the C_{bio} balance modifies the impacts of C-neutral assumptions, as shown in the C-complete curves in Fig. 5. The C-complete curves resemble the C-neutral ones, but with increasing or decreasing magnitude, given the two sequestration time perspectives. The same conclusions are drawn from the previous C_{bio} balance results (Fig. 4). The future sequestration lags behind the releases, while the opposite is the case for the historic perspective. The choice whether sequestration occurs before or after emissions thus considerably influences the results.

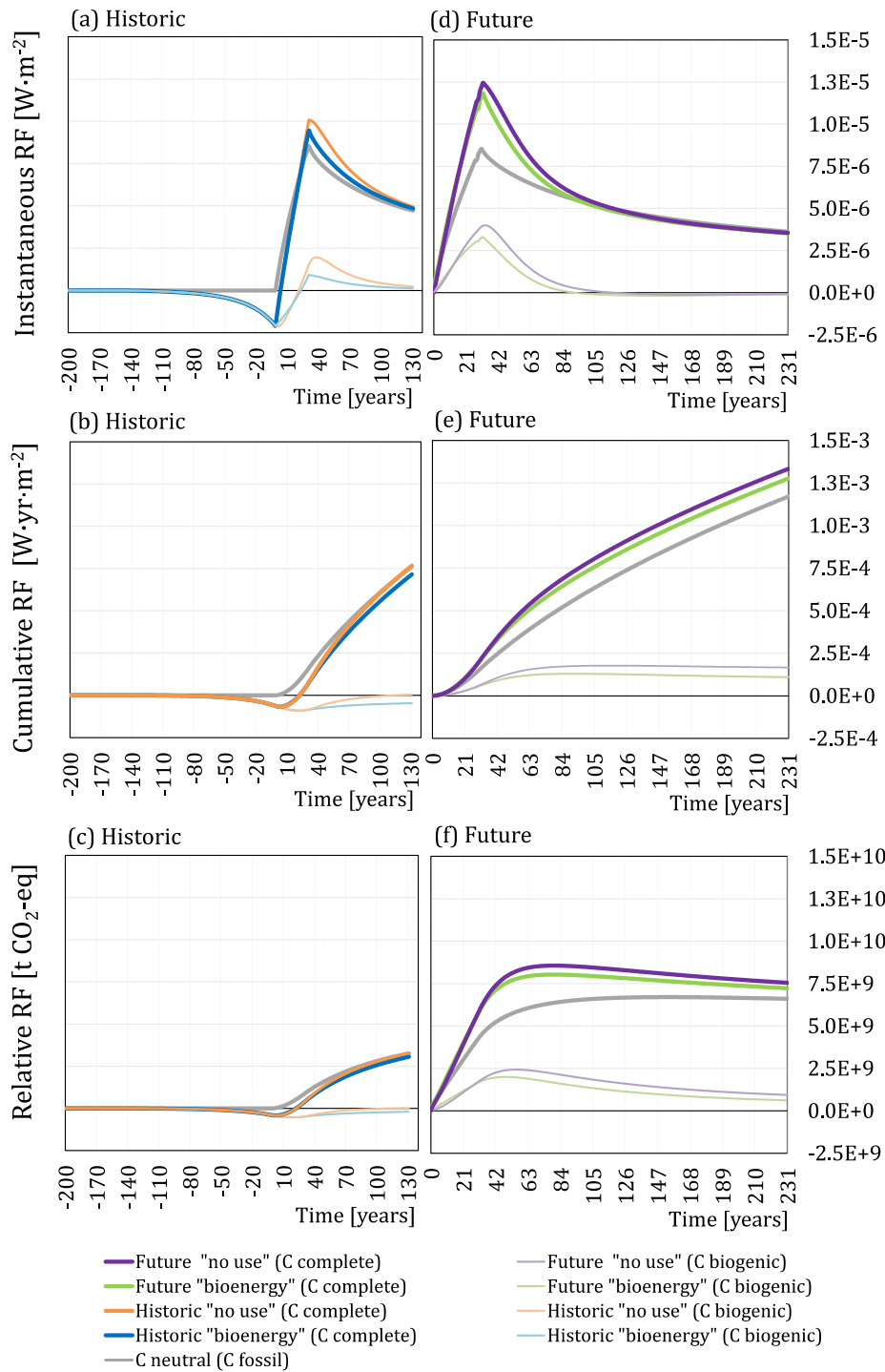

Fig. 5. Instantaneous [W·m⁻²], cumulative [W·yr·m⁻²], and relative [t CO₂-eq] radiative forcing (RF) effects from carbon (C) emissions assessed for C-biogenic from forest wood residues, C-fossil (carbon neutral) and C-Complete (fossil + biogenic) under given “bioenergy” and “no use” (reference) scenarios and sequestration modelling time perspectives (historic and future rotation cycles).

Moreover, a comparison between the bioenergy and the no use scenarios of both C-biogenic and C-complete, demonstrated that the impacts from 100% left behind FoWooR in the forest floor (reference), yielded higher forcing effects than for the bioenergy scenario in both historic and future modelling approaches. The emission flows are differentiated by their temporal distribution, which is either instantaneous (bioenergy) or gradual (decay). The anaerobic degradation processes produce CH₄ emissions with higher radiative efficiency than CO₂. Bioenergy and no use situations consider CH₄, as shown in Fig. 1, but the reference has a higher proportion of CH₄ emissions, as 100% of logging residues (including belowground biomass corresponding to FoWooR) are exposed to decay, compared to 30% for bioenergy. Consequently, the forcing effects of no use are higher than the bioenergy curve, as shown in Fig. 5.

3.3 Comparison of the two different temporal boundaries

The question arises on how to compare two opposing modelling approaches with different t_0 and LCIA THs (i.e. inventory time lengths). The application of the instantaneous or cumulative RF metrics allow a direct comparison between the historic or future time perspectives and scenarios, regardless when t_0 is set for the inventory and impact assessment. The results represent the actual impacts for any given GHG. On the other hand, the relative RF is based on the cumulative RF results relativized with the cumulative RF of the CO₂ reference gas, fixed to an initial year (t_0). The relative characterisation thus depends on the computation of a fixed t_0 . Consequently, the two time perspectives with different t_0 for C_{bio} sequestration are not comparable with the relative RF metric. It is most noticeable in the C-neutral curves in Fig. 5c, e, for instance by fixing the LCIA TH to 131 years, the impact would result in completely different magnitudes (i.e. 3.3E+9 for historic and 6.7E+9 for future perspectives). Following the complex comparison with dynamic CO₂-eq results, the relative RF metric is excluded from the comparison undertaken in this section.

Fig. 6 shows a comparison of the instantaneous (Fig. 6a) and cumulative (Fig. 6b) RF effects of the historic and future C-complete results, including C-neutral, highlighting the choice of reference LCIA THs aligned with both historic LCI TH (331 years) and future LCI TH (231 years). Aligning the LCIA THs is performed to ensure a consistent comparison of results with different LCI THs in a specific year, and test the time-sensitivity due to the choice of the LCIA TH. In this comparison, t_0 for historic is the year -200 and for future it the year 0. However, t_0 for future could also refer to the year -200 (equal to the historic one), as the range between -200 and 0 for the future perspective does not account for any emissions, and is therefore not assessed with the dynamic characterisation.

Concerning the cumulative results in Fig. 6b, an overall comparison denotes that the forcing effects for LCIA TH 231 are lower than for 331 years by around 60% for historic bioenergy ($7.2\text{E-}4$ and $1.1\text{E-}3 \text{ W}\cdot\text{yr}\cdot\text{m}^{-2}$) and no use ($7.7\text{E-}4$ and $1.2\text{E-}3 \text{ W}\cdot\text{yr}\cdot\text{m}^{-2}$), by around 70% for future bioenergy ($8.9\text{E-}4$ and $1.3\text{E-}3 \text{ W}\cdot\text{yr}\cdot\text{m}^{-2}$) and no use ($9.4\text{E-}4$ and $1.3\text{E-}3 \text{ W}\cdot\text{yr}\cdot\text{m}^{-2}$), and by 65% for C-neutral ($7.6\text{E-}4$ and $1.2\text{E-}3 \text{ W}\cdot\text{yr}\cdot\text{m}^{-2}$). The cumulative RF will continue increasing the longer the LCIA TH is set, due to the cumulated fraction of the CO_2 gas remaining in the atmosphere, which has a very long residence time. For the dynamic results, the highest difference was thus found, as expected, among the historic and future modelling time perspectives. However, the margin between both FoWooR scenarios itself is considerable small ranging between 4% and 7%, depending on the LCIA TH and time perspective.

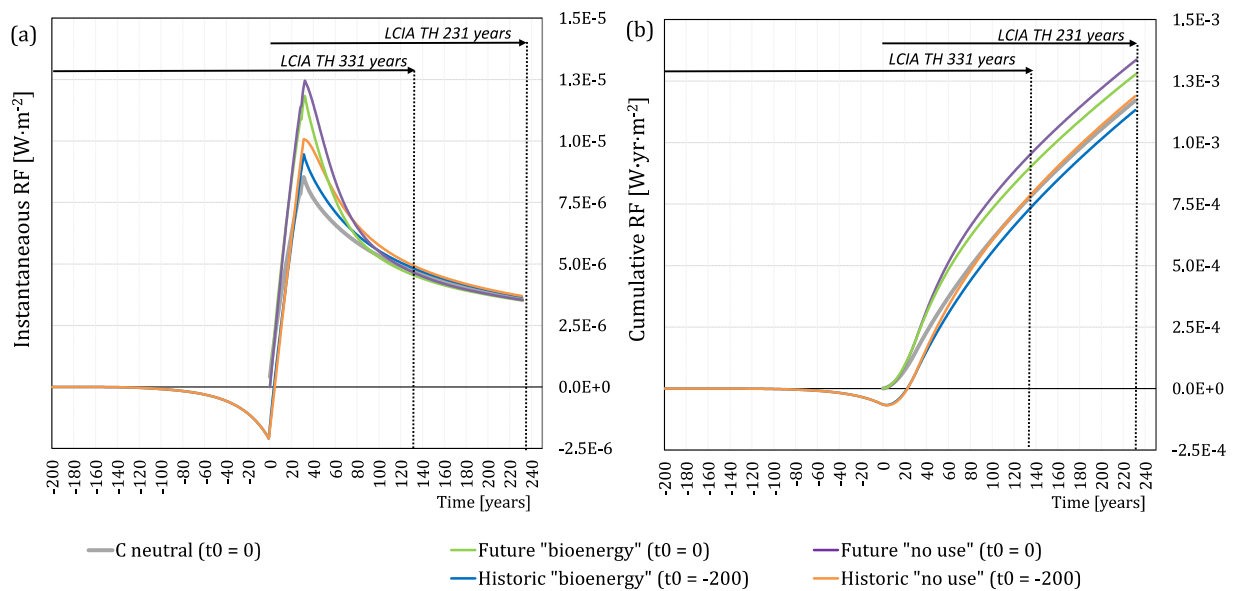

Fig. 6. Instantaneous [$\text{W}\cdot\text{m}^{-2}$] and cumulative [$\text{W}\cdot\text{yr}\cdot\text{m}^{-2}$] radiative forcing (RF) effects from carbon (C) neutral (fossil emissions only) and C-complete (fossil + biogenic flows from forest wood residues) under given “bioenergy” and “no use” (reference) scenarios and sequestration modelling time perspectives (historic and future rotation cycles). The arrows represent the setting of a life cycle impact assessment time horizon (LCIA TH) representing 231 and 331 years, for comparison purposes.

4 Discussion

4.1 Framing the carbon sequestration discussion

The results in this study demonstrated that the modelling choice for timing forest growth and thus C_{bio} sequestration, before or after, matters. It was also demonstrated that C_{bio} accounting differs from C-neutral assumptions (Fig. 6), as C_{bio} sequestration can have a cooling (negative RF) effect with an historic

perspective. However, when the sequestration lags behind release emissions in the future approach, a warming effect is observed, as pointed out by Helin et al. (2013) and confirmed in this study. After harvest activities, forest biomass needs to be replenished, which may take up to several centuries. Thus, modelling a full rotation length before the harvest yields a temporal carbon credit/benefit from an existing carbon stock, while modelling it after implies a temporal carbon debt/loss. In other words, carbon neutral results have been overestimated (historic) or underestimated (future) by the inclusion of dynamic C_{bio} flows.

4.2 Generalising rules for choosing a carbon sequestration modelling perspective: an allocation issue

The philosophical question from ancient Greece of whether the egg (sequestration) or the chicken (wood) comes first corresponds in the LCA methodology to an allocation issue: which sequestration, either before (historic) or after (future), should be attributed to a specific harvest? In this context, the chicken-egg dilemma arises in attributional LCA. In consequential LCA, the LCI modelling does not aim at allocating specific processes, such as C_{bio} sequestration, to specific products, such as harvested wood, but at representing the consequences of a change in decision or demand for the functional unit (Ekvall and Weidema 2004; Weidema et al. 2018). Therefore, the modelling principle for consequential LCA is to include all changes in C_{bio} flows related to a specific change and its effects on other systems, independently of their timing before or after the harvest. If the studied change relates to forest management (e.g. decrease of fertilisation rates), some modifications in C_{bio} flows can occur before harvest, but if this change relates to the harvest itself, consequences are likely to occur after harvesting (De Rosa et al. 2017).

In attributional LCA, the main consensual recommendation, e.g. from the ISO standard (ISO 2006a, b) or the ILCD handbook (EC-JRC 2010) to address an allocation issue, is to consider, when possible, an underlying causal physical relationship. In the case of managed forests, wood harvesting is possible because of the prior human activity of forest management; in that case, the time-related modelling should adopt an historic perspective. Conversely, in the case of non-managed forests, biomass growth and harvest are not linked by a causal relationship, but if the forest is allowed to re-grow after harvest, this regrowth and the related C_{bio} sequestration occur because of the harvest; the time-related modelling should then adopt a future perspective. Fig. 7 provides a decision tree for the choice of time-related modelling based on these criteria, which generalises the proposed set of decision rules. Solving the chicken-egg dilemma is closely linked with another well-known issue in the LCA community, i.e. determining whether biotic resources are part of the ecosphere or the technosphere, further explored in this section.

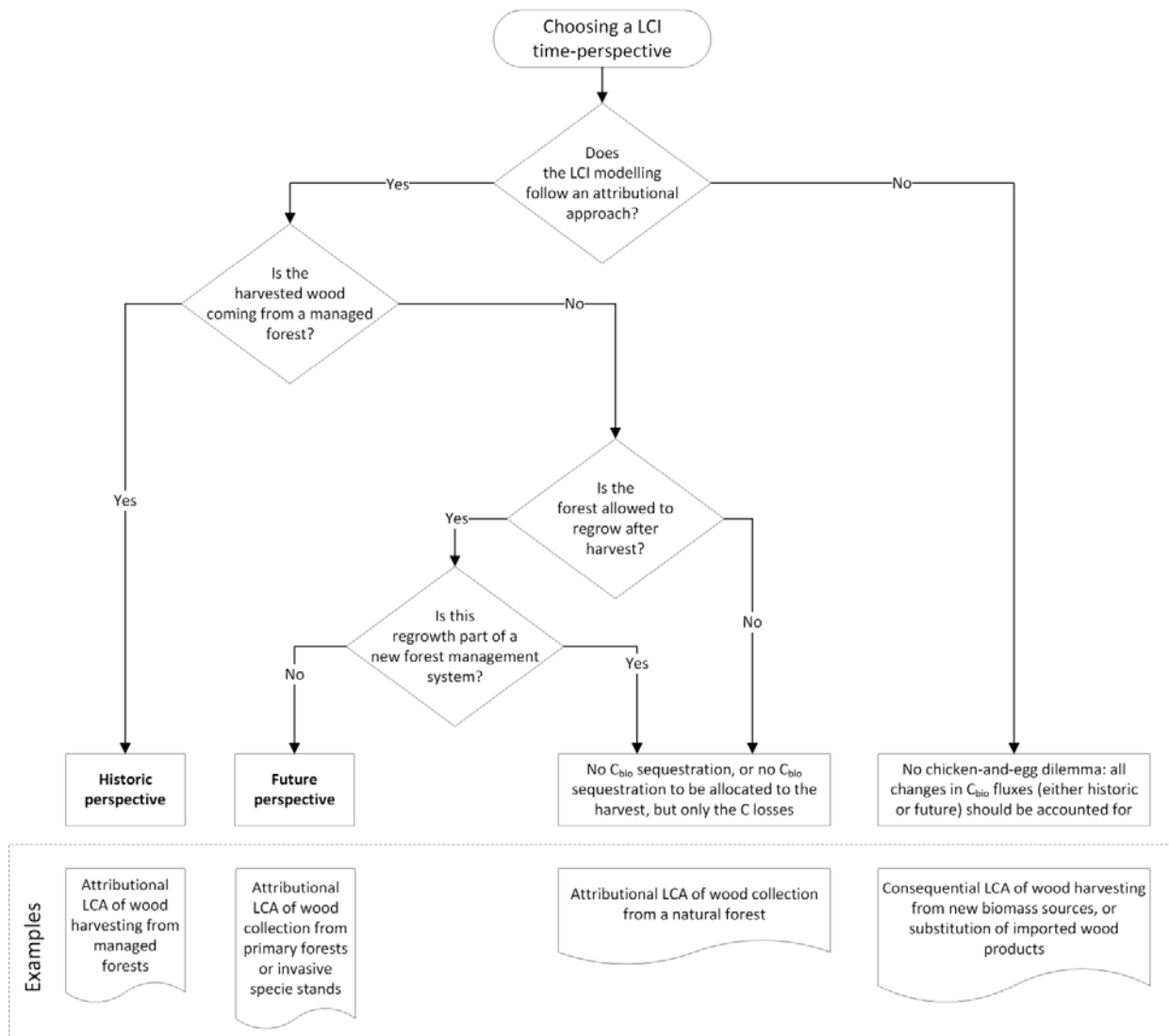

Fig. 7. Decision tree for the allocation of carbon sequestration to a harvest activities

4.3 Defining the origin of the biotic resource: *ecosphere or technosphere*

The origin of a biotic resource is likely the most dominant question for C_{bio} modelling through time, together with identifying the appropriate C_{bio} sequestration approach. According with Lindeijer and colleagues, the origin of the biotic resource defines whether the modelled system stems from a “man-made controlled culture” (e.g. agriculture, aquaculture and silviculture) or from a natural ecosystem (Lindeijer et al. 2002). The authors applied an established definition for aquaculture (FAO 1997) to specify intensity of human activities in controlled systems, narrowing it down to two key interventions: increasing reproduction/yield rate (e.g. plant seedlings, supply hatcheries, irrigation, fertilisation) and mean life expectancy (e.g. mechanical or chemical weed control, phytosanitary control). The question on where the

biotic resource extraction originates from, thus segregates the technosphere (anthropogenic) from the ecosphere (nature), and responds to which system the impacts from the extraction are allocated. The limits between the two spheres may therefore be determined to the level of human activities/interventions.

In the context of forest systems, managed and un-managed (including natural) forests should thus be differentiated. Managed forests imply ownership and are “primarily designated for the production of wood, fibre, bioenergy and/or non-wood forest products (e.g. arabic gum, latex, resin, Christmas trees, cork, bamboo)” (FAO 2010). The extraction of the biotic resource is possible due to planted seedlings (Lindeijer et al. 2002), meaning that the C_{bio} stocks are replenished and allowed to regrow. Additionally, in managed forests, species diversity is low. More than half of the French forests are monospecific and homogenous (IGN 2017). The human activity corresponds to reforestation, i.e. the reestablishment of a forest where it previously occurred, in contrast to afforestation where none previously existed (Lund et al. 2014). In sustainably managed forests, the carbon inventory does not decrease over time, as no more timber is removed than regrown (Lippke et al. 2011), as the aim is to “conserve and maintain forest ecosystems for the benefit of present and future generations” (FAO 2017).

In contrast to managed forests, natural forests “evolved and reproduced [regenerated] itself naturally from organisms previously established [native species], and that has not been significantly altered by human activity [ecological process are not significantly disturbed]” (FAO 2000, 2010). Natural forests are thus understood as previously/naturally existing, with insignificant or low level of human intervention. The same applies to un-managed forests, referring to abandoned/degraded forest or open woodland. A degraded forest features a reduction in quality, biomass, and species diversity induced by human activities (e.g. overexploitation, mismanagement) or natural disturbances (e.g. disease, pests, fires, windbreaks) (FAO 2000, 2011; Lund 2009, 2014).

From an economic/life cycle thinking viewpoint, managed forests (i.e. commercial forests) may be considered within the technosphere with the objective of providing and maximising the provision of biotic resources to meet future market demand. Un-managed forests (e.g. abandoned or degraded) may be considered as part of the ecosphere with no major economic intention. From an LCA viewpoint, un-managed forests could be considered equivalent to natural ones, as long as they are not part of a production system.

4.4 System changes beyond the chicken-egg dilemma

As per the previous segregation by the origin of the biotic resource between managed (technosphere) and un-managed/natural (ecosphere) forests, changes in land occupation are additional influencing criteria for modelling of C_{bio} sequestration (Fig. 7). Specific cases may be linked, for instance, to tree replacement with no forest covers (e.g. agriculture) and vice versa. Since prehistoric times, (agro)silvo-pastoral land

use systems (i.e. wood-pasture habitats) have been performed in Europe, yet banned since the 1800s (Bergmeier et al. 2010). It confirms that forest landscapes have been exploited and modified far back in history, disturbed by clear-cuts, agricultural practices and active restorations (Vasseur 2012).

For these specific cases, a land-use baseline is necessary, particularly when assessing systems producing food, feed, fibre, timber and biofuels (Soimakallio et al. 2015). This baseline describes the dynamic development of ecosystem towards the achievable “quasi-natural steady state” (Milà i Canals et al. 2007; Koellner et al. 2013). Among the different approaches proposed to establish a land-use baseline, for the selection of which there is no established guidance (Koponen et al. 2018), it has been argued that the most adequate one consists in using the ecosystem’s natural regeneration (also referred to as natural relaxation) to estimate impacts from land use in attributional LCA (Soimakallio et al. 2015, 2016). A study of wood production across Canada (Head et al. 2018) suggested that the use of natural forest as a baseline may take 1000 years without anthropogenic disturbance to approximate the steady-state carbon stock associated with a natural forest. Changes in land use and/or forest cover are beyond the scope of this work, as the chicken-egg dilemma does not apply to it.

4.4 System changes beyond the chicken-egg dilemma

As per the previous segregation by the origin of the biotic resource between managed (technosphere) and un-managed/natural (ecosphere) forests, changes in land occupation are additional influencing criteria for modelling of C_{bio} sequestration (Fig. 7). Specific cases may be linked, for instance, to tree replacement with no forest cover (e.g. agriculture) and vice versa. Since prehistoric times, (agro)silvo-pastoral land use systems (i.e. wood-pasture habitats) have been performed in Europe, yet banned since the 1800s (Bergmeier et al. 2010). It confirms that forest landscapes have been exploited and modified far back in history, disturbed by clear-cuts, agricultural practices and active restorations (Vasseur 2012).

For these specific cases, a land-use baseline is necessary, particularly when assessing systems producing food, feed, fibre, timber and biofuels (Soimakallio et al. 2015). This baseline describes the dynamic development of ecosystem towards the achievable “quasi-natural steady state” (Milà i Canals et al. 2007; Koellner et al. 2013). Among the different approaches proposed to establish a land-use baseline, for the selection of which there is no established guidance (Koponen et al. 2018), it has been argued that the most adequate one consists in using the ecosystem’s natural regeneration (also referred to as natural relaxation) to estimate impacts from land use in attributional LCA (Soimakallio et al. 2015, 2016). A study of wood production across Canada (Head et al. 2018) suggested that the use of natural forest as a baseline may take 1000 years without anthropogenic disturbance to approximate the steady-state carbon stock associated

with a natural forest. Changes in land use and/or forest cover are beyond the scope of this work, as the chicken-egg dilemma does not apply to it.

4.5 Different cases of dynamic carbon sequestration from forests and pertinent modelling perspective, excluding land use change situations

Different combinations of wood origin (ecosphere or technosphere), land cover (forest or non-forest) and type of forest (managed, unmanaged, natural, etc.) may be present on any particular C_{bio} sequestration modelling case study (Fig. 8).

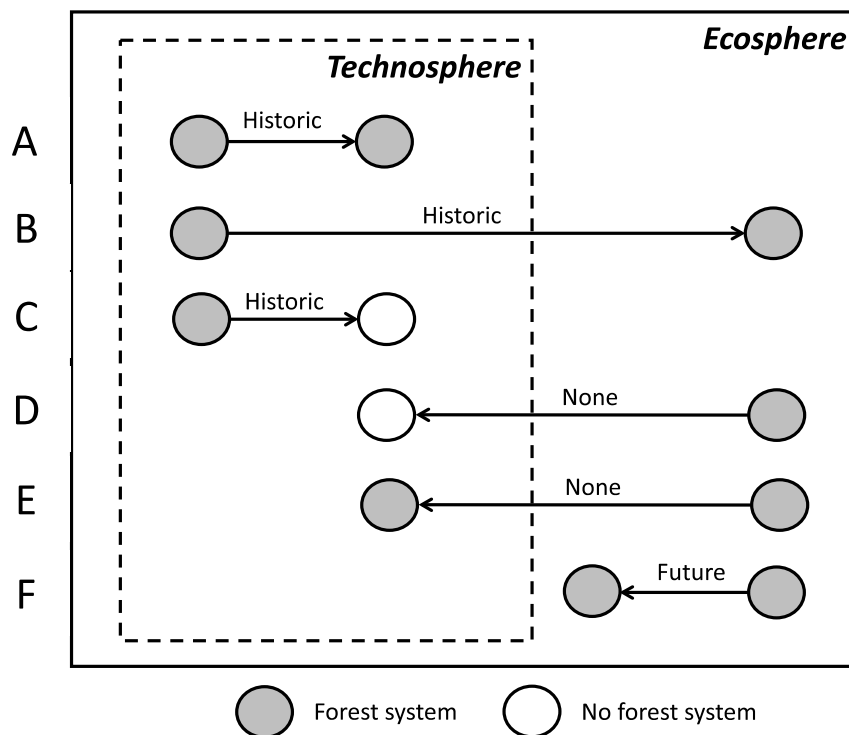

Fig. 8. Possible cases (A to F) of carbon accounting scenarios associated with the provision of forest regrowth (forest system) and no provision of forest regrowth (no forest system). The direction of the arrows represents the relation between the previous and the current life cycles

Fig. 8 reflects the reference frame of a forest wood providing system under study, highlighting the relevance of identifying the **previous** state of land occupation. Based on the circumstances (state) of the previous life cycle, a rationale for applying the historic or future modelling approaches may be derived:

- In cases A and B, harvested wood comes from a managed or unmanaged system, where the previous situation was a managed (i.e. in the technosphere) forest. In both cases, as there has been a human-induced C_{bio} sequestration, its modelling should be historical, as there is a history of

sequestration. In case A, even if there are management changes among rotations, historical sequestration should be applied, as there is no land use change (forest to forest).

- In case C, a special case of case A, in which a managed forest is harvested, and no provisions for regrowth are considered. As there is a history of sequestration, C accounting should be historical.
- In case D, a natural forest is harvested, and no provisions for regrowth are considered. Therefore, no C_{bio} sequestration can be attributed to the harvested wood, but a total loss of the C stocked in the natural forest.
- In case E, a natural forest is harvested and eventually converted into a managed technosphere system (forest to forest), and therefore no C_{bio} sequestration can be attributed to the harvested wood, but a total loss of the C stocked in the natural forest. After the management change is consolidated, for instance during a second cycle of technosphere forest, the situation would resemble case A.
- In case F, a natural forest is harvested and allowed to regrow without interventions such as reforestation, and no intention to turn the system into a managed forest. A future accounting of the natural regrowth should be carried out. In case that the regrowth is subject to interventions, that would be case E.

4.6 The case of bioenergy from residual forest biomass

The case of bioenergy in this study can be identified with case A in Fig. 8, as the biotic resource (here FoWooR) originates from a managed forest that has a history of consecutive sequestration cycles, and thus forms part of the technosphere. The modelling choice for sequestration we consider more coherent for this case, at least pertaining sustainable managed forests in France, is the historic perspective. Managed forests required long-term planning due to their nature of long rotation lengths, which should be credited with the historic sequestration accounting approach.

The forest cover in France has annually increased by 0.7% since 1985 (IGN 2017). It implies that managed forest is a net carbon sink rather than a net emitter. Future projections on standing wood volumes are based on historical datasets from long term field studies (yield tables with age and productivity classes) over the past centuries (INRA/ONF/ENGREF 1984) and statistical evaluations on potential future national availabilities from harvest behaviours and current production volumes, including losses and mortalities (Colin and Thivolle 2016). The additional annual carbon stocked per ha of land is expected to satisfy the anticipated increase in wood demand. A comparison with the TIMES-MIRET business as usual policy outputs (reference), following Albers et al. (2019a), showed that the FoWooR supply would increase gradually in the LTECV scenario, by 2.5% in the year 2030 and up to 17% in the year 2050. This

increment reflects the actual potential availability of French forests to sustainably supply 12 additional Mm³ of wood (Valade et al. 2018).

The wood supply chain in France amounts for 57.3 Mm³·yr⁻¹ (~16 Mha of which are managed forest, accounting for 31% of the land use), with 53% of the wood used for lumber, paper and pulpwood and 47% (~27.3 Mm³) for various bioenergy pathways (Agreste 2016; Valade et al. 2018). The wood residues from logging or thinning operations, when collected for the bioenergy sector, are considered as co-products from the forest wood supply chain. The co-product are destined to meet the raw material requirements of second generation biofuels and the energy mix, with on-site co-generation and other sectors such as domestic heating with pellets and wood chips, or blended transport-fuels with bioethanol and biodiesel.

A continuous sustainable forest growth and harvest will most likely not increase the removal of FoWooR due to displacement of fossil fuels (Lippke et al. 2011). It has been stated that increases in wood use for bioenergy beyond the transition policy targets (here LTECV scenario) are “unrealistic”, as it depends on the carbon stock and actual production (Valade et al. 2018). However, it may lead to intensifying forest management practices and any additional mobilisation may imply the use of quality wood with high added value (dedicated biomass) for bioenergy.

5 Conclusions

Accounting for dynamic biogenic flows from forest biomass allows valuing C_{bio} sequestration of forest-bioenergy systems. C_{bio} sequestration postpones RF over several decades (cooling effect). The negative forcing effects, however, depend on the timing of sequestration. When the sequestration lags behind the releases (future sequestration cycle), the positive emissions overtake the negative with subsequent opposite effects, namely warming (positive RF). A carbon debt is created and it takes a full rotation length to compensate for the caused GHG costs. As demonstrated in this study, excluding the dynamic features of C_{bio} flows introduces bias and may mislead decision support. Forest ecosystems are dynamic and mitigation targets require dynamic approaches, showcasing time-dependency of carbon flows, as well as the time-sensitive implications for climate change. Carbon neutrality is not an option for modelling biotic resources with long rotation lengths. The dynamic LCA method is a constructive approach for timing fossil and C_{bio} flows both upstream and downstream the supply chain/life cycle of bio-based products. Dynamic models are closer to real applications compared with linear assumptions or default carbon stock values.

This study was concerned with finding a solution to the allocation issue associated with the chicken-egg dilemma of C_{bio} sequestration, attributing a future or historic perspective to a specific forestry biomass harvest. This study did not address modelling challenges associated with land use change, as those are

beyond the chicken-egg dilemma. A decision tree (Fig. 7) supports the choice of time-related modelling based on a generalised set of decision rules for attributional approaches underlined by different cases (Fig. 8).

Our proposals are limited to the comparison of prospective bioenergy scenarios at the product level. The dynamic at the landscape level may differ from those at the product level, and therefore further research is needed to close the gap between forest stand and landscape levels. Moreover, consequences on the soil organic carbon dynamic over time due to an increased demand of forest wood residues have not been considered. In a broader sense, such exploitation might affect forest ecosystem services involving biodiversity and the sustainable provision of goods and services (e.g. soil productivity and ecosystem functioning) in the long term. Further research is needed to respond to this concern, by addressing changes of carbon stock in the soil (in this study, for instance, we included decay of wood biomass in soil), but also by performing a complete LCA study including other impact categories.

References for Paper 2

- Agostini A, Giuntoli J, Boulamanti A (2014) Carbon accounting of forest bioenergy critical literature review. EC JRC Scientific policy reports Rep EUR 25354 1–87. doi: 10.2788/29442
- Agreste (2016) Forêts, bois et dérivés. In: Ministère de l'Agriculture et de l'Alimentation. <http://agreste.agriculture.gouv.fr/enquetes/forets-bois-et-derives/>. Accessed 12 Dec 2017
- Albers A, Collet P, Lorne D, et al (2019a) Coupling partial-equilibrium and dynamic biogenic carbon models to assess future transport scenarios in France. *Appl Energy* 239:316–330. doi: 10.1016/j.apenergy.2019.01.186
- Albers A, Collet P, Benoist A, Hélias A (2019b) Data and non-linear models for the estimation of biomass growth and carbon fixation in managed forests. *Data Br* 23:1–8. doi: 10.1016/j.dib.2019.103841
- Benoist A (2009) *Éléments d'adaptation de la méthodologie d'analyse de cycle de vie aux carburants végétaux : cas de la première génération*. PhD thesis. École Nationale Supérieure des Mines de Paris
- Bergmeier E, Petermann J, Schröder E (2010) Geobotanical survey of wood-pasture habitats in Europe: Diversity, threats and conservation. *Biodivers Conserv* 19:2995–3014. doi: 10.1007/s10531-010-9872-3
- Brandão M, Kirschbaum MUF, Cowie AL, Hjulær SV (2019) Quantifying the climate change effects of bioenergy systems: Comparison of 15 impact assessment methods. *GCB Bioenergy* 1–17. doi: 10.1111/gcbb.12593
- Brandão M, LévassEUR A, Kirschbaum MUF, et al (2013) Key issues and options in accounting for carbon sequestration and temporary storage in life cycle assessment and carbon footprinting. *Int J Life Cycle Assess* 18:230–240. doi: 10.1007/s11367-012-0451-6
- BSI (2008) *Guide to PAS 2050: How to assess the carbon footprint of goods and services*. British Standard. London

Chapter 4: Forestry: growth modelling

- Cacot E, Eisner N, Charnet F, et al (2006) La récolte raisonnée des rémanents en forêt. ADEME-Agence de l'environnement et de la maîtrise de l'énergie. Paris
- Cardellini G, Mutel CL, Vial E, Muys B (2018) Temporalis, a generic method and tool for dynamic life cycle assessment. *Sci Total Environ* 645:585–595. doi: 10.1016/j.scitotenv.2018.07.044
- Cherubini F, Fuglestvedt J, Gasser T, et al (2016) Bridging the gap between impact assessment methods and climate science. *Environ Sci Policy* 64:129–140. doi: 10.1016/j.envsci.2016.06.019
- Cherubini F, Peters GP, Berntsen T, et al (2011a) CO₂ emissions from biomass combustion for bioenergy: atmospheric decay and contribution to global warming. *GCB Bioenergy* 3:413–426. doi: 10.1111/j.1757-1707.2011.01102.x
- Cherubini F, Strømman AH, Hertwich E (2011b) Effects of boreal forest management practices on the climate impact of CO₂ emissions from bioenergy. *Ecol Modell* 223:59–66. doi: 10.1016/j.ecolmodel.2011.06.021
- Christensen TH, Gentil E, Boldrin A, et al (2009) C balance , carbon dioxide emissions and global warming potentials in LCA-modelling of waste management systems. *ISWA* 707–715. doi: 10.1177/0734242X08096304
- Colin A, Thivolle A (2016) Disponibilités en bois d'origine forestière à l'horizon 2035. Tome 1: rapport. ADEME/IGN/FCBA. Paris
- Collet P, Hélias A, Lardon L, Steyer J-P (2011) Time and Life Cycle Assessment: How to Take Time into Account in the Inventory Step? 618. doi: 10.1007/s11367-013-0678-x
- Colomb V, Bernoux M, Bockel L, et al (2012) Review of GHG calculators in agriculture and forestry sectors: A guideline for appropriate choice and use of landscape based tools. ADEME-Agence de l'environnement et de la maîtrise de l'énergie. Paris
- Cowie A, Berndes G, Smith T (2013a) On the timing of greenhouse gas mitigation benefits of forest-based bioenergy. *ExCo:2013:04*. IEA Bioenergy. Dublin
- Cowie A, Berndes G, Smith T (2013b) On the Timing of Greenhouse Gas Mitigation Benefits of Forest-Based Bioenergy. Dublin
- Daystar J, Venditti R, Kelley SS (2016) Dynamic greenhouse gas accounting for cellulosic biofuels: implications of time based methodology decisions. *Int J Life Cycle Assess* 1–15. doi: 10.1007/s11367-016-1184-8
- De Rosa M, Schmidt J, Brandão M, Pizzol M (2017) A flexible parametric model for a balanced account of forest carbon fluxes in LCA. *Int J Life Cycle Assess* 22:172–184. doi: 10.1007/s11367-016-1148-z
- Demertzi M, Paulo JA, Faias SP, et al (2018) Evaluating the carbon footprint of the cork sector with a dynamic approach including biogenic carbon flows. *Int J Life Cycle Assess* 23:1448–1459. doi: 10.1007/s11367-017-1406-8

- Earles JM, Halog A, Ince P, Skog K (2013) Integrated economic equilibrium and life cycle assessment modeling for policy-based consequential LCA. *J Ind Ecol* 17:375–384. doi: 10.1111/j.1530-9290.2012.00540.x
- EC-JRC (2010) International Reference Life Cycle Data System (ILCD) Handbook: Analysing of existing Environmental Impact Assessment methodologies for use in Life Cycle Assessment. European Commission Joint Research Centre (JRC) contract, Ispra
- EC (2009) DIRECTIVE 2009/28/EC on the promotion of the use of energy from renewable sources and amending and subsequently repealing Directives 2001/77/EC and 2003/30/EC
- Ekvall T, Weidema BP. (2004) System Boundaries and Input Data in Consequential Life Cycle Inventory Analysis. *Int J Life Cycle Assess* 9:161–171. doi: 10.1065/Ica2004.03.148
- Eriksson O, Finnveden G, Ekvall T, Björklund A (2007) Life cycle assessment of fuels for district heating: A comparison of waste incineration, biomass- and natural gas combustion. *Energy Policy* 35:1346–1362. doi: 10.1016/j.enpol.2006.04.005
- FAO (1997) Review of the state of the world fishery resources: Marine Fisheries. FAO-Food and Agricultural Organization of the United Nations, Rome
- FAO (2010) Terms and Definitions. Global Forest Resource Assessment. Working Paper 144/E. Forest Resources Assessment Programme, Food and Agriculture Organization of the United Nations, Rome
- FAO (2017) Natural Forest Management: Sustainable forest management. In: Food Agric. Organ. United Nations. <http://www.fao.org/forestry/sfm/en/>. Accessed 30 Jan 2019
- FAO (2000) Asia-Pacific Forestry Commission: Development of National-Level Criteria and Indicators for the Sustainable Management of Dry Forests of Asia: Workshop Report. FAO-Food and Agricultural Organization of the United Nations, Bangkok
- FAO (2011) Assessing forest degradation: Towards the development of globally applicable guidelines. Food and Agriculture Organization, Rome
- Fearnside PM (2002) Why a 100-Year Time Horizon should be used for GlobalWarming Mitigation Calculations. *Mitig Adapt Strateg Glob Chang* 7:19–30. doi: 10.1023/A:1015885027530
- Fearnside PM, Lashof DA, Moura-Costa P (2000) Accounting for time in mitigating global warming through land-use change and forestry. *Kluwer Acad Publ* 5:239–270. doi: 10.1023/A:1009625122628
- Fekedulegn D, Mac Siurtain MP, Colbert JJ (1999) Parameter estimation of nonlinear growth models in forestry. *Silva Fenn* 33:327–336. doi: 10.14214/sf.653
- Fouquet M, Levasseur A, Margni M, et al (2015) Methodological challenges and developments in LCA of low energy buildings: Application to biogenic carbon and global warming assessment. *Build Environ* 90:51–59. doi: 10.1016/j.buildenv.2015.03.022

Chapter 4: Forestry: growth modelling

- Gargiulo M, Brian O (2013) Long-term energy models: Principles, characteristics, focus, and limitations. *WIREs Energy Env* 2:158–177. doi: 10.1002/wene.62
- Grewer U, Bockel L, Schiettecatte L-S, Bernoux M (2017) Ex-Ante Carbon-balance Tool (EX-ACT). Quick Guidance. Rome: Food and Agriculture Organization of the United Nations
- Guinée JB, Gorrée M, Heijungs R, et al (2002) Handbook on life cycle assessment. Operational guide to the ISO standards. I: LCA in perspective. Iia: Guide. Iib: Operational annex. III: Scientific background. Kluwer Academic Publishers, Dordrecht
- Haberl H, Sprinz D, Bonazountas M, et al (2012) Correcting a fundamental error in greenhouse gas accounting related to bioenergy. *Energy Policy* 45:18–23. doi: 10.1016/j.enpol.2012.02.051
- Harvey M, Pilgrim S (2011) The new competition for land: Food, energy, and climate change. *Food Policy* 36:S40–S51. doi: 10.1016/j.foodpol.2010.11.009
- Head M, Bernier P, Levasseur A, et al (2018) Forestry carbon budget models to improve biogenic carbon accounting in life cycle assessment. *J Clean Prod* 213:289–299. doi: 10.1016/J.JCLEPRO.2018.12.122
- Heijungs R, Suh S (2002) The computational structure of life cycle assessment. *Kluwer Acad Publ* 7:314–314. doi: 10.1007/BF02978899
- Helin T, Sokka L, Soimakallio S, et al (2013) Approaches for inclusion of forest carbon cycle in life cycle assessment - A review. *GCB Bioenergy* 5:475–486. doi: 10.1111/gcbb.12016
- Henry M, Bombelli A, Trotta C, et al (2013) GlobAllomeTree: International platform for tree allometric equations to support volume, biomass and carbon assessment. *IForest* 6:326–330. doi: 10.3832/ifor0901-006
- Hischier R, Weidema B, Althaus H-J, et al (2010) Implementation of Life Cycle Impact Assessment Methods Data v2.2 (2010)
- IGN (2017) Le memento inventaire forestier édition 2017. In: IGN-Institut Natl. l'information géographique For. https://inventaire-forestier.ign.fr/IMG/pdf/memento_2017.pdf. Accessed 20 Jul 2018
- INRA/ONF/ENGREF (1984) Tables de production pour les forêts françaises, 2e édition. INRA-Centre National de Recherche Forestières, ONF- Office National des Forêts, ENGREF- Ecole Nationale du Génie rural, des Eaux et des Forêts, Nancy
- IPCC (2006a) Chapter 4. Agriculture, forestry and other land use. In: Eggleston S, Buendia L, Miwa K, et al. (eds) 2006 IPCC Guidelines for National Greenhouse Gas Inventories. Intergovernmental Panel on Climate Change, Prepared by the National Greenhouse Gas Inventories Programme
- IPCC (2006b) IPCC guidelines for national greenhouse gas inventories. Chapter 4. agriculture, forestry and other land use

- IPCC (2013) *Climate Change 2013 The Physical Science Basis. Contribution of Working Group I to the Fifth Assessment Report of the Intergovernmental Panel on Climate Change*. Cambridge University Press, Cambridge and New York
- ISO (2006a) *ISO 14040 Environmental management — Life cycle assessment — Principles and framework*. The International Standards Organisation. Geneva
- ISO (2006b) *ISO 14044 Environmental management — Life cycle assessment — Requirements and guidelines*. The International Standards Organisation. Geneva
- Johnson E (2009) Goodbye to carbon neutral: Getting biomass footprints right. *Environ Impact Assess Rev* 29:165–168. doi: 10.1016/j.eiar.2008.11.002
- Joos F, Bruno M (1996) Pulse response functions are cost-efficient tools to model the link between carbon emissions, atmospheric CO₂ and global warming. *Phys Chem Earth* 21:471–476. doi: 10.1016/S0079-1946(97)81144-5
- Jørgensen S V, Hauschild MZ (2013) Need for relevant timescales when crediting temporary carbon storage. *Int J Life Cycle Assess* 747–754. doi: 10.1007/s11367-012-0527-3
- Kendall A, Davis A, Studies T, et al (2009) Accounting for time-dependent effects in biofuel life cycle greenhouse gas emissions calculations. *Environ Sci Technol* 43:7142–7147. doi: 10.1021/es900529u
- Koellner T, de Baan L, Beck T, et al (2013) Principles for life cycle inventories of land use on a global scale. *Int J Life Cycle Assess* 18:1203–1215. doi: 10.1007/s11367-012-0392-0
- Koponen K, Soimakallio S, Kline KL, et al (2018) Quantifying the climate effects of bioenergy – Choice of reference system. *Renew Sustain Energy Rev* 81:2271–2280. doi: 10.1016/j.rser.2017.05.292
- Korhonen R, Pingoud K, Savolainen I, Matthews R (2002) The role of carbon sequestration and the tonne-year approach in fulfilling the objective of climate convention. *Environ Sci Policy* 5:429–441. doi: 10.1016/S1462-9011(02)00091-6
- Levasseur A, Bahn O, Beloin-Saint-Pierre D, et al (2017) Assessing butanol from integrated forest biorefinery: A combined techno-economic and life cycle approach. *Appl Energy* 1–13. doi: 10.1016/j.apenergy.2017.04.040
- Levasseur A, Brandão M, Lesage P, et al (2012a) Valuing temporary carbon storage. *Nat Clim Chang* 2:1–3. doi: 10.1038/nclimate1335
- Levasseur A, Cavalett O, Fuglestvedt JS, et al (2016) Enhancing life cycle impact assessment from climate science: Review of recent findings and recommendations for application to LCA. *Ecol Indic* 71:163–174. doi: 10.1016/j.ecolind.2016.06.049
- Levasseur A, Lesage P, Margni M, et al (2010) Considering time in LCA: Dynamic LCA and its application to global warming impact assessments. *Environ Sci Technol* 44:3169–3174. doi: 10.1021/es9030003

Chapter 4: Forestry: growth modelling

- Levasseur A, Lesage P, Margni M, et al (2012b) Assessing temporary carbon sequestration and storage projects through land use, land-use change and forestry: comparison of dynamic life cycle assessment with ton-year approaches. *Clim Change*. doi: 10.1007/s10584-012-0473-x
- Levasseur A, Lesage P, Margni M, Samson R (2012c) Biogenic Carbon and Temporary Storage Addressed with Dynamic Life Cycle Assessment. *J Ind Ecol* 17:117–128. doi: 10.1111/j.1530-9290.2012.00503.x
- Lindeijer E, Müller-Wenk R, Bengt S (2002) Impact Assessment of Resources and Land Use. In: de Haes HAU, Finnveden G, Goedkoop M, et al. (eds) *Life-Cycle Impact Assessment: Striving towards Best Practice*. Society of Environmental Toxicology and Chemistry (SETAC), pp 11–64
- Lippke B, Oneil E, Harrison R, et al (2011) Life cycle impacts of forest management and wood utilization on carbon mitigation: knows and unknowns. *Carbon Manag* 2:303–333
- Lorne D, Tchong-Ming S (2012) The French biofuels mandates under cost uncertainty – an assessment based on robust optimization. IFPEN. Rueil-Malmaison
- Loulou R, Lehtilä A, Kanudia A, et al (2016) Documentation for the TIMES Model PART II: Reference Manual. ETSAP-Energy Technology Systems Analysis Programme
- Lund HG (2014) What is a forest? Definitions do make a difference an example from Turkey. *Eurasscience Journals* 2:1–8
- Lund HG (2009) What is a degraded forest? 1. White paper prepared for FAO. Forest Information Services, Gainesville
- Lund MT, Berntsen TK, Fuglestvedt JS (2014) Climate impacts of short-lived climate forcers versus CO₂ from biodiesel: A case of the EU on-road sector. *Environ Sci Technol* 48:14445–14454. doi: 10.1021/es505308g
- Marvuglia A, Benetto E, Rege S, Jury C (2013) Modelling approaches for consequential life-cycle assessment (C-LCA) of bioenergy: Critical review and proposed framework for biogas production. *Renew Sustain Energy Rev* 25:768–781. doi: 10.1016/j.rser.2013.04.031
- Menten F, Tchong-ming S, Lorne D, Bouvart F (2015) Lessons from the use of a long-term energy model for consequential life cycle assessment: The BTL case. *Renew Sustain Energy Rev* 43:942–960. doi: 10.1016/j.rser.2014.11.072
- Milà i Canals L, Bauer C, Depestele J, et al (2007) Key Elements in a Framework for Land Use Impact Assessment Within LCA. *Int J Life Cycle Assess* 12:5–15. doi: 10.1065/lca2006.05.250
- Montes F, Cañellas I (2006) Modelling coarse woody debris dynamics in even-aged Scots pine forests. *For Ecol Manage* 221:220–232. doi: 10.1016/j.foreco.2005.10.019

- Moura Costa P, Wilson C (2000) An equivalence factor between CO₂ avoided emissions and sequestration - Description and application in forestry. *Mitig Adapt Strateg Glob Chang* 5:51–60. doi: 10.1023/A:1009697625521
- MTES (2017) Chiffres clés du climat France et Monde. MTES Ministère de la transition écologique et solidaire. Paris
- Newell JP, Vos RO (2012) Accounting for forest carbon pool dynamics in product carbon footprints: Challenges and opportunities. *Environ Impact Assess Rev* 37:23–36. doi: 10.1016/j.eiar.2012.03.005
- Nicolas C, Saint-Antonin V, Tchong-Ming S (2014) (How) does sectoral detail affect the robustness of policy insights from energy system models? The refining sector's example. Université de Paris Ouest Nanterre La Défense. Paris
- O'Hare M., Plevin RJ, Martin JI, et al (2009) Proper accounting for time increases crop-based biofuels' greenhouse gas deficit versus petroleum. *Environ Res Lett* 4:1–7. doi: 10.1088/1748-9326/4/2/024001
- Pawelzik P, Carus M, Hotchkiss J, et al (2013) Critical aspects in the life cycle assessment (LCA) of bio-based materials - Reviewing methodologies and deriving recommendations. *Resour Conserv Recycl* 73:211–228. doi: 10.1016/j.resconrec.2013.02.006
- Peñaloza D, Erlandsson M, Falk A (2016) Exploring the climate impact effects of increased use of bio-based materials in buildings. *Constr Build Mater* 125:219–226. doi: 10.1016/j.conbuildmat.2016.08.041
- Peñaloza D, Røyne F, Sandin G, et al (2018) The influence of system boundaries and baseline in climate impact assessment of forest products. *Int J Life Cycle Assess*. doi: 10.1007/s11367-018-1495-z
- Pingoud K, Ekholm T, Soimakallio S, Helin T (2016) Carbon balance indicator for forest bioenergy scenarios. *GCB Bioenergy* 8:171–182. doi: 10.1111/gcbb.12253
- Pommerening A, Muszta A (2015) Methods of modelling relative growth rate. *For Ecosyst* 2:5. doi: 10.1186/s40663-015-0029-4
- Pretzsch H (2009) *Forest Dynamics, Growth and Yield- From Measurement to Model*. Springer-Verlag, Berlin Heidelberg
- Rathmann R, Szklo A, Schaeffer R (2010) Land use competition for production of food and liquid biofuels: An analysis of the arguments in the current debate. *Renew Energy* 35:14–22. doi: 10.1016/j.renene.2009.02.025
- Repo A, Tuovinen JP, Liski J (2015) Can we produce carbon and climate neutral forest bioenergy? *GCB Bioenergy* 7:253–262. doi: 10.1111/gcbb.12134
- Richards FJ (1959) A flexible growth function for empirical use. *J Exp Bot* 10:290–300. doi: 10.1093/jxb/10.2.290.
- Ros JPM, van Minnen JG, Arets EJMM (2013) Climate effects of wood used for bioenergy. PBL Netherlands Environmental Assessment Agency. The The Hague. doi 10.1002/bbb.1407

Chapter 4: Forestry: growth modelling

- Royne F, Peñaloza D, Sandin G, et al (2016) Climate impact assessment in life cycle assessments of forest products: implications of method choice for results and decision- making. *J Clean Prod* 116:90–99. doi: 10.1016/j.jclepro.2016.01.009
- Scarlat N, Dallemand J, Monforti-ferrario F, Banja M (2015) Renewable energy policy framework and bioenergy contribution in the European Union – An overview from National Renewable Energy Action Plans and Progress Reports. *Renew Sustain Energy Rev* 51:969–985. doi: 10.1016/j.rser.2015.06.062
- Searchinger TD, Hamburg SP, Melillo J, et al (2009) Fixing a critical climate accounting error. *Sci* 326(5952):527–528. doi: 10.1126/science.1178797
- Shine KP, Fuglestvedt JS, Hailemariam K, Stuber N (2005) Alternatives to the Global Warming Potential for comparing climate impacts of emissions of greenhouse gases. *Clim Change* 68:281–302. doi: 10.1007/s10584-005-1146-9
- Soimakallio S, Brandão M, Ekvall T, et al (2016) On the validity of natural regeneration in determination of land-use baseline. 448–450. doi: 10.1007/s11367-016-1032-x
- Soimakallio S, Cowie A, Brandão M, et al (2015) Attributional life cycle assessment: is a land-use baseline necessary? *Int J Life Cycle Assess* 20:1364–1375. doi: 10.1007/s11367-015-0947-y
- UNFCCC (2019) Clean development mechanism projects of the United Nations Framework Convention on Climate Change. In: United Nations Framew. Conv. Clim. Chang. <https://cdm.unfccc.int/Projects/index.html>. Accessed 22 Jan 2019
- UNFCCC (2014) A Summary of the Kyoto Protocol. In: United Nations Framew. Conv. Clim. Chang. http://unfccc.int/kyoto_protocol/background/items/2879.php. Accessed 2 Feb 2018
- Valade A, Luyssaert S, Vallet P, et al (2018) Carbon costs and benefits of France’s biomass energy production targets. *Carbon Balance Manag* 13:26. doi: 10.1186/s13021-018-0113-5
- Vasseur L (2012) Restoration of Deciduous Forests. *Nat Educ* 3:
- Vázquez-Rowe I, Marvuglia A, Rege S, Benetto E (2014) Applying consequential LCA to support energy policy: Land use change effects of bioenergy production. *Sci Total Environ* 472:78–89. doi: 10.1016/j.scitotenv.2013.10.097
- Vogtländer JG, Van Der Velden NM, Van Der Lugt P (2014) Carbon sequestration in LCA, a proposal for a new approach based on the global carbon cycle: Cases on wood and on bamboo. *Int J Life Cycle Assess* 19:13–23. doi: 10.1007/s11367-013-0629-6
- Weidema BP, Pizzol M, Schmidt J, Thoma G (2018) Attributional or consequential Life Cycle Assessment: A matter of social responsibility. *J Clean Prod* 174:305–314. doi: 10.1016/j.jclepro.2017.10.340

- Wiloso EI, Heijungs R, Huppes G, Fang K (2016) Effect of biogenic carbon inventory on the life cycle assessment of bioenergy: Challenges to the neutrality assumption. *J Clean Prod* 125:78–85. doi: 10.1016/j.jclepro.2016.03.096
- Wise M, Calvin K, Thomson A, et al (2009) Implications of limiting CO₂ concentrations for land use and energy. *Science* (80-) 324:1183–1186. doi: 10.1126/science.1168475
- Yan Y (2018) Integrate carbon dynamic models in analyzing carbon sequestration impact of forest biomass harvest. *Sci Total Environ* 615:581–587. doi: 10.1016/j.scitotenv.2017.09.326
- Zanchi G, Pena N, Bird N (2010) The upfront carbon debt of bioenergy
- Zetterberg L, Chen D (2015) The time aspect of bioenergy - climate impacts of solid biofuels due to carbon dynamics. *GCB Bioenergy* 7:785–796. doi: 10.1111/gcbb.12174

4.4 Chapter conclusions

This chapter demonstrated that accounting for forest- C_{bio} sequestration challenges the current static carbon neutral and renewable energy displacement approaches by means of timing biogenic carbon flows (both sequestration and release) and time-sensitive climate change impacts. The consumption of forest wood feedstock for the energy-transport sector has a net zero CO_2 balance, in the long-term featuring the same results as the classical static carbon footprint results. However, the timing of the C_{bio} flows allows taking into account the temporal sequestration effect of the forest-sourced biomass.

The sequestration depends on the **tree species and forest management practices** (i.e. thinning, rotation length) and the chosen modelling approach (future or historic time perspective). Long-term sequestration further postpones radiative forcing, thus increasing the mitigation effect. Yet, the mitigation effect is sensitive on the rotation length: the shorter the growth/rotation length the lower the mitigation effect. Changes of the growth parameter, on the other hand, have not affected the results, given the robustness of the model.

On the other hand, the timing of the first C_{bio} sequestration with historic or future modelling time perspectives determines whether there is an initial carbon benefit or debt. The **chicken-egg-dilemma** of C_{bio} sequestration is rooted in physical causal relationship handled in attributional LCA (attribution of historic or future C_{bio} sequestration to a harvest activity). Generalised rules have been developed to recommend the appropriate dynamic C_{bio} modelling relevant for both LCI modelling approaches (attributional and consequential). The recommendations intended to support the justification of applying one approach over the other based on the discrepancy between wood provision from **managed and un-managed** (i.e. identifying the **previous state** of the land occupation) and defining whether the harvest wood biomass is allowed to **regrow**.

The two case studies in Paper 1 and Paper 2, however, focused only on forest-sourced biomass for the bioenergy sector and C_{bio} sequestration due to tree (re)growth, excluding biomass demand from other biotic resources (e.g. annual or perennial energy crops) from agricultural systems and their dynamic features. Wood decay was modelled based on a simplified method, ignoring other dynamic influencing factors of potential C inputs to soil in the context of the soil organic carbon (SOC) dynamic as well as potential carbon sequestration in the soil. The next chapter contributes to integrating the dynamic of SOC in the proposed modelling framework, involving dynamic land use implications, linked with the climate change impact category.

Chapter 5:
Agriculture: Soil organic carbon
modelling

5 Agriculture: Soil organic carbon modelling

5.1 Chapter context

The C_{bio} balance of bioenergy from annual energy crops is usually considered carbon neutral, as the C_{bio} sequestration during plant growth and the C_{bio} releases from end-of-life (EOL) combustion takes place within the one year time step. While this may be applicable for crop products (e.g. sugar beet for bioethanol production), other remaining plant parts (in the above- and belowground plant compartments) usually contribute to soil organic matter, as they are left on the field, incorporated to the topsoil, and eventually contributing to soil organic carbon (SOC). The dead biomass has its own dynamic, as it undergoes decay processes, affecting the atmospheric GHG composition over time.

The purpose of this chapter is thus modelling of dynamic SOC flows upstream of different agricultural bioenergy substrates and evaluates the temporal carbon effects of these flows on the atmospheric GHG composition, linking climate change impacts. Analogously to the C_{bio} sequestration dynamic of forest-sourced biomass (Chapter 4), time-sensitive effects from biogenic sources (here SOC flows) modelled, involving biomass growth dynamic for energy crops with rotation lengths longer than one year (e.g. perennial grasses).

The framework elements (Chapter 3) addressed by Paper 3 and Manuscript 4 and their supplementary materials (Appendix F: SM of Paper 3 and Appendix G: SM of Manuscript) are indicated in Fig. 3-15.

The case study in **Paper 3** aims at modelling the C inputs to the soil from different biomass commodities (energy crops) from a partial-equilibrium model (here TIMES-MIRET) for transport-biofuels, by applying the same coupling approach proposed in Paper 1 (section 4.2). The SOC modelling refers to C inputs to the soil from different crop fractions considered as residues, including external C inputs from biowastes (organic fertilisers), per unit of area under consideration of land occupation scenarios.

Manuscript 4 is a short case study of an intermediate chemical product (surfactant for self-care products) partially based on fatty alcohol from palm kernel oil (PKO). The purpose of the case study is to model the dynamic C_{bio} and SOC upstream and downstream flows of PKO, described in an existing classical static “cradle-to-gate” LCA study (provided by the French chemical company Solvay), and compare static with dynamic results. The approach is a model integration of all previously developed case studies, increasing the complexity in growth modelling all oil palm crop compartments.

Paper 3 and Manuscript 4 respond to the following research questions:

Paper 3 (section 5.2):

- Do complete carbon balances (involving SOC flows) of biofuels differ from balances based on carbon neutral assumptions (considering only fossil C)? To what extent?
- Are complete carbon balances sensitive to the SOC modelling parameters and/or changes in C inputs to soil?
- What plant fractions from above- and belowground compartments do contribute to higher levels C inputs to the soil? Is this specific to the source crop?

Manuscript 4 (section 5.3):

- How can the dynamic C_{bio} and SOC flows be coupled with classical static LCA approaches? What are the restrictions or limitations?
- How are the classical static LCA results influenced by the full lifetime biogenic accounting of the surfactant product? Does accounting for C_{bio} of this type of product matter? Are the results sensitive to changes in model parameters?
- Do the results differ significantly under consideration of hypothetical scenarios variations (e.g. assuming extended service-life, other EOL scenarios)?

The main technical specifications on modelling steps building the basis of the modelling framework applied in the research paper and manuscript are shortly summarised, as follows. A detail modelling scheme has been included in Paper 3.

Pre-treatment steps for the model coupling:

1. Export demand model outputs linking energy crop commodity [t], annualising the values with linear interpolation, and quantify carbon content of annual values [t Cyr⁻¹].
2. Compute land use/occupation per unit of area requirements [ha] of the energy crop demand based on yield proportions [t·ha⁻¹] (crop product or residues) and chemical composition of crops (sugar, oil, starch) [t·t⁻¹].
3. Compute final energy supply [MJ] per process pathway based on low-heating value, yield efficiencies and well-to-wheel approaches and associated greenhouse gas emissions [t CO₂eq·MJ⁻¹]

Dynamic soil organic carbon modelling steps:

Chapter 5: Agriculture: Soil organic carbon modelling

4. Model C inputs to the soil originating from dead organic matter (i.e. plant residues above- and belowground and external inputs) using soil organic carbon (SOC) modelling approaches by Hénin and Dupuis (1945) and AMGv2 (Clivot et al., 2019) models.
5. Model soil parameters based on soil texture, soil type and climate typology for national crops
6. Model plant C allocation/partitioning among different plant compartments based on the net primary productivity (see Box 5-1) approaches.
7. Model potential C of exogenous biowaste inputs (organic soil amendment/fertiliser) [t C·ha⁻¹].
8. Quantify C input flows [t C·ha⁻¹] by means correction factors on the C allocated values to specific plant compartments, determining management practices or scenarios (residue removal rate, root incorporation, exogenous input).
9. Compute the derivative values to obtain dynamic soil organic carbon factors [t C·yr⁻¹] per crop species or the mean of all species.

Box 5-1. Net Primary Production

Net primary production (NPP) can be understood as the net amount of energy stored in the biomass. It reflects the balance between the net carbon gain in the plant thorough photosynthesis during plant growth and the carbon release through plant respiration/metabolism and biological residue in form of CO₂. It includes the NPP of new biomass (40-70%), root secretions (20-40%), transfer microbes by symbiosis (10-30%), losses (1-40%) and volatile emissions (0-5%) (Chapin III and Eviner, 2007; Clark et al., 2001; Gower et al., 2001).

5.2 Paper 3: Soil organic carbon in the context of energy crops

This paper assesses the soil organic carbon dynamic and land occupation from agricultural energy crops (annual and perennial) and the time-sensitive climate change consequences from emerging transport biofuels by contrasting both carbon neutral with and without SOC inventories, published in the Journal Science of Total Environment (<https://doi.org/10.1016/j.scitotenv.2019.135278>), received 19 August 2019, accepted 28 October 2019.

Objective	Develop dynamic SOC inventories from the provision of agricultural substrates to transport biofuels, to: Evaluate implications of SOC on climate change Compare and discuss the SOC-climate consequences from different energy policy scenarios and biofuel pathways Identify the main sources of mitigation potentials (i.e. emission delay)
Approach	Coupling annual and perennial biomass commodity outputs from a partial-equilibrium model with dynamic SOC models
Sector (product)	Transport (bioethanol and biodiesel)
Biomass	Annual crops (rapeseed, maize, triticale, wheat, sunflower, sugar beet and soybean) Perennial grasses (miscanthus and switchgrass) Biowastes from livestock farming
Supporting data	Data Paper in section Appendix D: Data paper on forest models: Model coupling strategy SOC modelling data as Supplementary Material in Appendix F: SM of Paper 3

Modelling dynamic soil organic carbon flows of annual and perennial energy crops to inform energy-transport policy scenarios in France

Ariane Albers ^{a, b, c, *}, Angel Avadí ^{c, d, f}, Anthony Benoist ^{c, e, f}, Pierre Collet ^a, Arnaud Hélias ^{b, g, h}

^a IFP Energies Nouvelles, 1 et 4 Avenue de Bois-Préau, 92852 Rueil-Malmaison, France

^b LBE, Montpellier SupAgro, INRA, UNIV Montpellier, Narbonne, France

^c Elsa, Research Group for Environmental Lifecycle and Sustainability Assessment, Montpellier, France

^d CIRAD, UPR Recyclage et risque, F-34398 Montpellier, France

^e CIRAD, UPR BioWooEB, F-34398 Montpellier, France

^f Univ Montpellier, CIRAD, Montpellier, France

^g Chair of Sustainable Engineering, Technische Universität Berlin, Berlin, Germany

^h ITAP, Irstea, Montpellier SupAgro, Univ Montpellier, ELSA Research Group, Montpellier, France

* Corresponding author

Graphical abstract

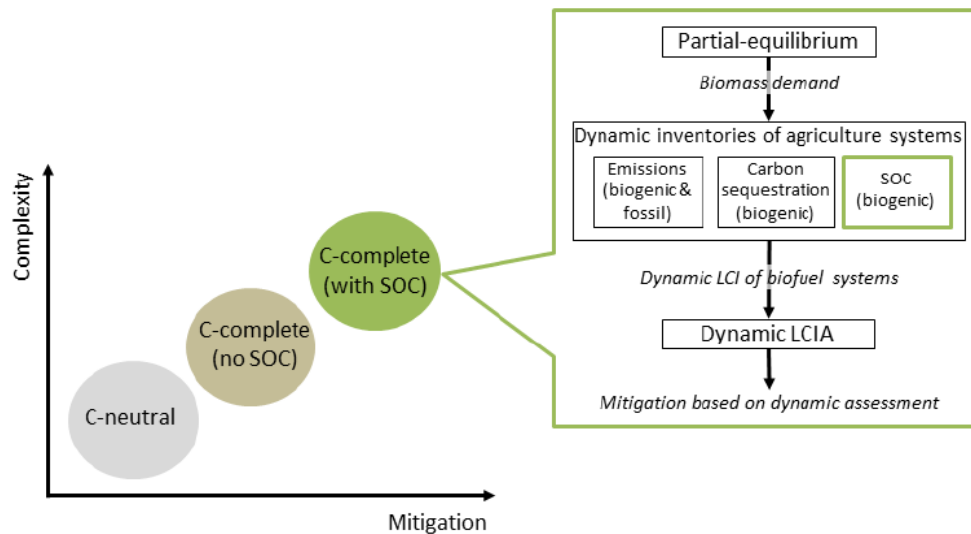

Highlights

- Dynamic accounting of SOC from land use activities linked with energy crops for transport biofuels
- The modelling framework contributes to complete GHG inventories including biogenic C and SOC
- Mitigation potentials are sensitive to residue management (C inputs to the soil vs. removal rates)
- Temperature affects organic matter decay and thus mitigation effects
- Soil C sequestration from perennial is higher than that from annual crops

Abstract

Low carbon strategies recently focus on soil organic carbon (SOC) sequestration potentials from agriculture and forestry, while Life Cycle Assessment (LCA) increasingly becomes the framework of choice to estimate the environmental impacts of these activities. Classic LCA is limited to static carbon neutral approaches, disregarding dynamic SOC flows and their time-dependent GHG contributions. To overcome such limitation, the purpose of this study is to model SOC flows associated with agricultural land use (LU) and the provision of agricultural substrates to transport biofuels, thus generating dynamic inventories and comparatively assessing energy policy scenarios and their climate consequences in the context of dynamic LCA. The proposed framework allows computing SOC from annual and perennial species under specific management practices (e.g. residue removal rates, organic fertiliser use). The results associated with the implementation of three energy policies and two accounting philosophies (C-neutral

and C-complete) show that shifting energy pathways towards advanced biofuels reduces overall resource consumption, LU and GHG emissions. The French 2015 Energy Transition for Green Growth Act (LTECV) leads towards higher mitigation targets compared with business-as-usual (BAU) and intermediate (15BIO) policy constraints. C-neutral results show reduced radiative forcing effects by 10% and 34% for 15BIO and LTECV respectively, but not for BAU. C-complete (i.e. dynamic assessment of all biogenic- and fossil-sourced C flows) results reveal further mitigation potentials across policies, whereof 50%-65% can be attributed to temporal C sequestration in perennial rhizomes. A sensitivity analysis suggests important SOC variations due to temperature increase (+2°C) and changes in residue removal rates. Both factors affect mitigation and the latter also LU, by a factor of -0.56 to +5. This article highlights the importance of SOC modelling in the context of LU in LCA, which is usually disregarded, as SOC is considered only in the context of land use change (LUC).

Keywords: Biofuels; dynamic life cycle assessment; energy policy scenarios; land use; residue management; SOC modelling

1 Introduction

1.1 Energy policies and low carbon mitigation strategies

Greenhouse Gas (GHG) emissions need to be reduced by 60% until 2050 (EC, 2018a; UNFCCC, 2018). Between 1990 and 2016, GHG emissions of EU-28 showed a relative reduction by 22% in most economic sectors, due to efficiency increases and changes in the energy mix, however, for the transport sector including international aviation, they have increased by 26% (EUROSTAT, 2019). In France, 70% of GHG emissions are attributed to fuel combustion, of which about 30% derive from the transport sub-sector (SDES, 2019). Climate-energy policy targets promote a shift towards renewable energy (RE) and advanced biofuels. French policy formulates increasing RE-shares in the energy mix and transport sectors, by 32% and 15% (from a 2012 baseline (MTES, 2018)) respectively, as well as reducing GHG emissions by 40% (from a 1990 baseline (IPCC, 2006)).

Low carbon strategies include the use of energy crops for producing transport-biofuels, as they are RE carriers considered as carbon neutral GHG inventories. Most of these feedstock consist of dedicated food-crop based annual species (e.g. rapeseed, wheat), as well as lignocellulosic dedicated perennial species and residual matter, among other non-food crop derived biomass such as algae. Advanced second generation (2G) biofuels, i.e. based on perennial grasses, woody residues, and agricultural straw, are increasingly encouraged, as they do not displace food production, regardless of their alleged potential contribution to indirect LUC (Harvey and Pilgrim, 2011).

Additional mitigation strategies focus on the potential of carbon sequestration in soils through agricultural practices (Goglio et al., 2015), promoted for instance under the “4 per mille Soils for Food Security and Climate” initiative presented at the 21st Conference of the Parties of the UNFCCC, which resulted in the 2015 Paris Climate Agreement (CGIAR, 2018; Derrien et al., 2016; INRA, 2019; Minasny et al., 2017; Zanella et al., 2018). This initiative faces nonetheless some criticism on the extent to which soil can sequester carbon (e.g. White et al. 2018) and the concept of soil carbon sequestration itself, as the release of nutrients is one of the key functions of soil organic matter (SOM) (Lehmann and Kleber, 2015). Therefore, the dynamic of soil organic carbon (SOC), as influenced by biomass production and use, needs further research when modelling climate benefits of future energy scenarios.

Prospective bottom-up energy system models are instruments assessing policy scenarios and their effects on a (sub-) sector, by means of linear programming and optimisation (Loulou et al., 2016). Scenario simulations from these models are built on least cost and low carbon energy pathways, involving technological innovation, efficiency and RE from fossil and biomass sources. The dynamic of SOC and LU are however not considered in energy system models (Frank et al., 2015).

1.2 Soil organic carbon modelling and application in life cycle assessment

SOC is the main component of SOM, accounting for 55-60% by mass, divided among three pools: fast/labile/active (turnover time of 1-2 years), intermediate (turnover time of 10-100 years), and slow/refractory/stable (turnover time of >100 years) (FAO, 2017). The turnover rate plays a key role in the functioning (e.g. health) of the soil ecosystem, as well as on climate change, as C is eventually released to the atmosphere, as it undergoes continuous decomposition in the soil under influence of soil fauna activity (Kwiatkowska-Malina, 2018; Lehmann and Kleber, 2015; Campbell and Paustian, 2015; FAO, 2017). Several physical and biochemical mechanisms may influence the decomposition rate, and these mechanisms can be in turn influenced by management (e.g. to increase C sequestration) (Wiesmeier et al., 2019; Zomer et al., 2017).

In general, SOC models take into consideration soil temperature, water, and clay content; as main drivers for changes in C stocks (Bockstaller and Girardin, 2010; Ci et al., 2015; FAO, 2017; Han et al., 2018; Zhong et al., 2018). They are usually based on the assumption that SOM decomposes following first order kinetics (Smith et al., 2012), initially proposed in the 1945 pioneering model from Hénin and Dupuis (Henin and Dupuis, 1945; Shibu et al., 2006), where the decomposition rate constant corresponds to the pedoclimatic condition-dependent annual mineralisation rate. Mineralisation coefficients can be estimated from measured data (e.g. Delphin 2000) or modelled (Benbi and Richter, 2002; Bockstaller and Girardin, 2010), and are often available in the literature (e.g. Gobin et al. 2011).

SOC modelling in agriculture, livestock, climate mitigation and LCA are carried out by means of different methods depending on the purpose of the study, data availability and spatial scales (i.e. site-specific, site-dependent or site-generic variables). Common classifications involve three levels of complexity (Bolinder et al., 2006; Campell and Paustian, 2015; FAO, 2018; Goglio et al., 2018, 2015; Shibu et al., 2006; Smith et al., 2012): i) analytical/empirical models, mostly based on the factors from IPCC Guideline for National GHG Inventories (IPCC, 2006), ii) process-oriented/conceptual models, with increasing complexity according with the number of pools considered, and iii) ecosystem/summary models, i.e. multi-compartment models involving sub-models such as plant growth, dynamic crop-soil-crop models etc.

Analytical modelling methods are based on two main rationales: gain-loss, where processes altering C content of pools are considered, and stock-difference, most common in LCA, where C stocks in pools are measured at two points in time (Benoist and Bessou, 2018; IPCC, 2006). Empirical models, such as the Campbell model (Campell and Paustian, 2015), use two functions to describe changes in SOC: one to model C dynamics associated with organic inputs (i.e. residues) and another for the decomposition of pre-existing SOC (Liang et al., 2005; Smith et al., 2012). These models have also been used to assess the C sequestration potentials of specific crops, such as the one proposed in Grogan and Matthews (2002) for energy crops (short rotation coppice willow). Other analytical models include the two-compartment (i.e. active and stable) Introductory Carbon Balance Model (ICBM) (Andr n and K tterer, 1997) and variations of the three-compartment model first presented by Andriulo et al., (1999a), such as the AMG model (Clivot et al., 2019; Duparque et al., 2013; Saffih-Hdadi and Mary, 2008). The use of such models requires site-dependent coefficients (e.g. degradation rates; effects of clay, humidity and temperature). Complex dynamic models, on the other hand, aim at answering questions beyond C or N sequestration: their goal is to predict the performance of specific agricultural systems involving site-specific (i.e. local) calibrations.

LCA generally requires simple, site-generic models, which are useful under a variety of conditions and require a minimal amount of input data. Two models widely used in LCA, the monthly time-stepped C-TOOL (Petersen, 2003) and the daily to annually time-stepped RothC (Coleman and Jenkinson, 2014), demand a larger number of input parameters than ICBM or AMG models (Campell and Paustian, 2015; Goglio et al., 2015). Complex agro-ecosystem models such as CANDY, CENTURY, CERES-EGC, DAYCENT, DAISY, DNDC and STICS have been occasionally used in LCA (Brilli et al., 2017; Campell and Paustian, 2015; Goglio et al., 2015; Gueudet, 2012), but the required level of expertise and data hinder their widespread applicability.

1.3 Land activities in the context of soil organic carbon modelling

In LCA, two types of activities are modelled in relation with SOC, namely LUC and LU, the latter referring to use of a land over time not involving LUC. LUC is associated with “transformation” and LU to “occupation”, two keywords used in LCA software to identify these two elementary flows. Depending on methods and data availability, land management changes (LMC) can be modelled as either transformation or occupation processes (Benoist and Bessou, 2018). LMC-related agricultural practices potentially affecting SOC dynamics include management of agricultural residues, organic fertilisation and the selection of high-biomass crops and rotations (Goglio et al., 2015, 2014).

The original ILCD handbook (EC-JRC, 2010) recommended a widely used single-indicator model for calculating the impacts of transformation and occupation, based on changes in soil quality, expressed in terms of SOM (Milà i Canals et al., 2007a, 2007b). More recently, the Product Environmental Footprint (EC, 2018b; Sala S. et al., 2019) suggested the multi-indicator models LANCA (Bos et al., 2016) and latest LANCA v2.5 (Horn and Maier, 2018). Regarding SOC modelling itself, mostly characterisation factors and simple models are used in LCA, yet no recommended or consensus model exists (Goglio et al., 2018, 2015). For instance, the PEFCR guidelines (EC, 2018b) recommend the PAS 2050 approach (BSI, 2011) to be used for all C emissions and removals arising from LUC, but PAS 2050 does in turn recommend using IPCC methods (for LCIs) and reporting SOC-related results separately. The IPCC approaches for SOC modelling (Tiers 1 and 2, and characterisation factors), include only the topsoil (first 30 cm), thus disregarding intermediate and stable pools.

The UN Environment (formerly UNEP-SETAC) Life Cycle Initiative recommends the same SOM-based approach to occupation and transformation of land as IPCC, yet it also recommends a specific method for SOC impacts on C sequestration and climate change (Koellner et al., 2013). This method, described in Müller-Wenk and Brandão (2010), provides factors for C losses to air, from an initial stock in soil (estimated per biome), associated to various types of occupation and transformation. It is one of the few approaches, together with Schmidinger and Stehfest (2012), a method under development (Benoist and Cornillier, 2016), and project-oriented methods based on IPCC (e.g. under the Kyoto Protocol’s Clean Development Mechanism, <https://cdm.unfccc.int/methodologies/index.html>), considering the impacts on climate change via C sequestration and release of both transformation and occupation of soils (Benoist and Bessou, 2018). Table 1 summarises the features of some of these modelling approaches used in LCA.

Table 1. Comparison of recommended static modelling approaches for calculating soil quality SOM/SOC changes associated with land use (occupation) and land use change (transformation) in LCA

Method	Recommending guideline	Land activities included	Usefulness for LCIA	Notes
SOM/SOC change (Brandão and Milà i Canals, 2013; Milà i Canals et al., 2007a, 2007b)	International Reference Life Cycle Data System (EC-JRC, 2010)	T+O	CF available, limited linking to AoP	Informing soil quality, site-dependent or -generic, but not climate change
LANCA (Beck et al., 2010; Bos et al., 2016; Horn and Maier, 2018)	Product Environmental Footprint Category Rules (EC, 2018b)	T+O	CF available	Informing soil functions, data intensive, suitable for site-dependent or generic assessment
SALCA-SQ (Oberholzer et al., 2012, 2006)	ecoinvent v2 (Nemecek et al., 2011; Nemecek and Kagi, 2007)	O	CF available, limited linking to AoP	Informing soil properties and treats, site-dependent or site-specific (plot level)
Müller-Wenk and Brandão (2010)	UNEP-SETAC (Koellner et al., 2013)	T+O	CF available	Informing climate change, site-generic (6 biomes over the world)
PAS 2050 standard (BSI, 2011) and IPCC Guideline for National GHG Inventories (IPCC, 2006)	Product Environmental Footprint Category Rules (EC, 2018b)	T	N/A	Dynamic modelling in the context of CDM methodologies, but site-dependent

Acronyms. AoP: Area of Protection, SOC: Soil Organic Carbon, SOM: Soil Organic Matter, T: Transformation; O: Occupation, LCIA: Life Cycle Impact Assessment, CF: characterisation factors, GHG: Greenhouse Gas, CDM: Kyoto Protocol's Clean Development Mechanism
Sources: Benoist and Bessou (2018)

Regarding biofuels, the effect of LU and LUC on soil C dynamics, as well as that of residue management practices (i.e. removal rates of residues exploited as RE carriers), are of key interest (Brandão et al., 2011; Caldeira-Pires et al., 2018; Smith et al., 2012). The overall potential C sequestration of energy crops is computed and estimated to be positive (Lemus and Lal, 2005; Mi et al., 2014; Zang et al., 2018). Moreover, the need for time dynamic SOC modelling in LCA has been highlighted (Brandão et al., 2013, 2011; Sommer and Bossio, 2014). A first effort in that direction is the approach to include SOC changes in LCA proposed by Petersen et al. (2013), which relies on the Bern Carbon Cycle Model to determine degradation curves, the superposition of which allows, by mass-balance, to estimate the amount of C remaining in soils by the end of the assessment time horizon (TH).

1.4 Goal and scope of the study

Based on such environment of evolving SOC modelling approaches and applications in LCA, the goal of this work is to propose a dynamic SOC modelling approach for life cycle inventories associated with LU and agricultural substrates to biofuels. The proposed approach would contribute to overcoming identified gaps of SOC modelling in LCA, namely, the consideration of: SOC associated with LU, SOC dynamic within a given reference TH, and the need for accessible SOC models in LCA. Furthermore, the resulting dynamic SOC inventories are integrated into a dynamic model-coupling framework with a partial-equilibrium model (PEM) as proposed in Albers et al., (2019a), to comparatively assess future energy-transport scenarios and climate change consequences associated with SOC. A key aspect of the proposed approach is its dynamic representation of SOC associated with the dynamic technical flows of the system, to more accurately estimate climate change impacts.

The functional unit in this study represents the annual energy demand, in MJ, over the prospective PEM simulation period (2019 to 2050), defined per policy constraint, here to satisfy the energy consumption of transport end-users, in this study referring to bioethanol and biodiesel from agricultural energy crops

2 Material and methods

The construction of dynamic SOC inventories associated with energy policy scenarios and LU, follows the model-coupling framework specified in Fig. 1. The framework allows computing dynamic SOC flows from agricultural annual and/or perennial energy crops under specific (yet variable) management practices (e.g. residue removal, or organic fertiliser use). The SOC model includes C inputs to the soil stemming from aboveground (AG) and belowground (BG) plant compartments, as well as from exogenous (EX) sources (i.e. organic fertilisers). Site-dependent coefficients, such as temperature and soil characteristics, relate to the crop cultivation in France, except for soybean, which is assumed to be imported from Brazil.

Firstly, the technical flows obtained from the energy system model (it could have been any other demand model) are exported to a) inform SOC modelling on the biomass commodity supply, b) compute LU requirements, and c) represent the results specific to two selected transport-biofuel (bioethanol and biodiesel) pathways per biomass commodity. Secondly, annualised “C-complete” balances are built by combining dynamic accounting of biogenic- (here referring to SOC flows) and fossil- (referring to C neutral flows without biogenic flows) sourced CO₂ elementary flows, which are subsequently assessed with time-dependent characterisation factors in the context of dynamic LCA (Levasseur et al., 2010). This study does not represent a complete LCA, as it solely focuses on modelling dynamic life cycle inventories of SOC and their climate change consequences.

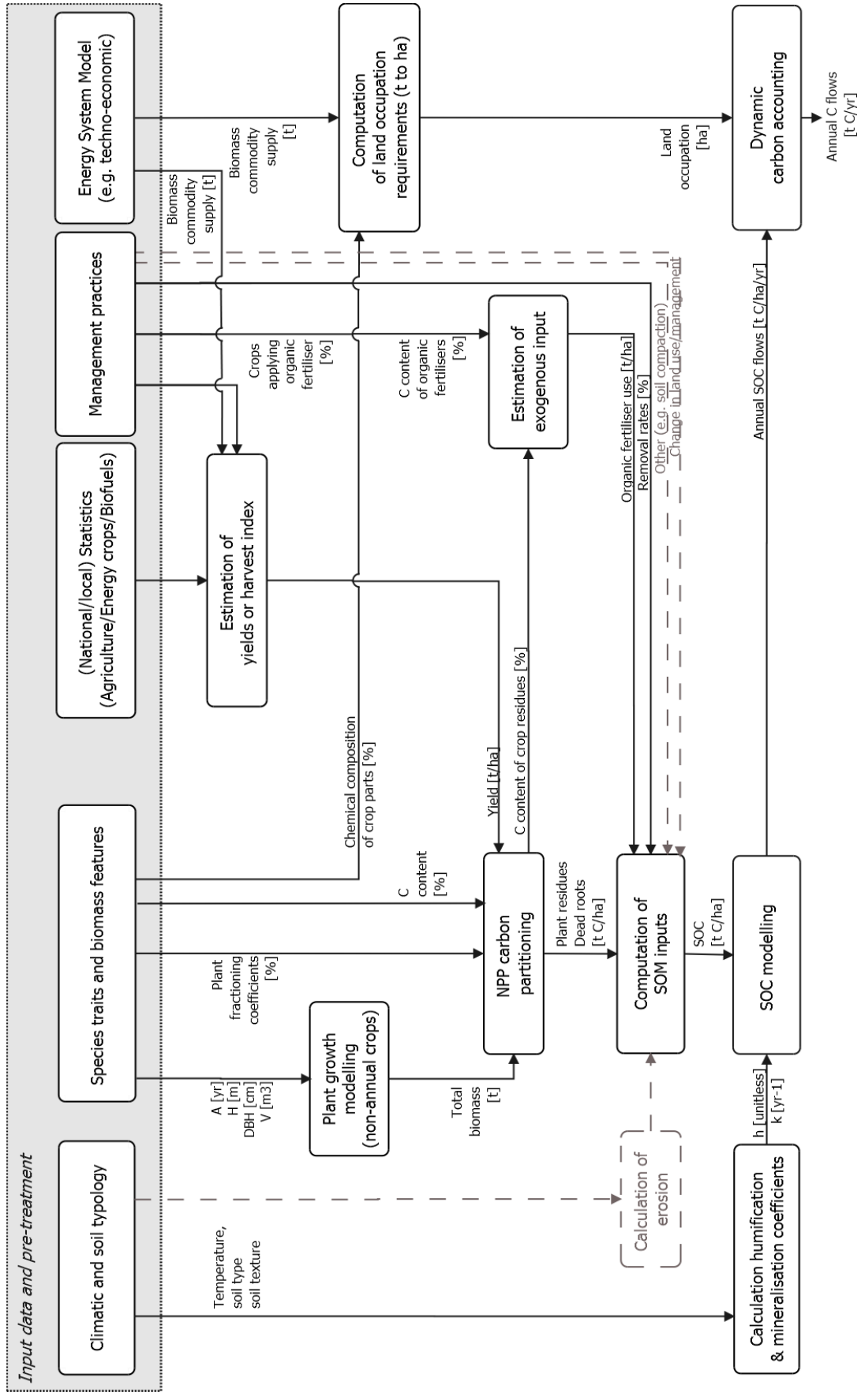

Fig. 1. Coupling diagram of energy system and soil organic carbon modelling for dynamic carbon accounting (Acronyms: A: Age, C: Carbon content, DBH: Diameter Breast Height, H: Height, h: Humification coefficient, k: Mineralisation coefficient, NPP: Net Primary Productivity, SOC: Soil Organic Carbon, V: Volume)

2.1 Processing model outputs from the energy system model

2.1.1 Demand model informing policy scenarios for the transport sub-sector

Prospective bottom-up energy system models are instruments assessing policy scenarios and their effects on a (sub-) sector by means of linear programming and optimisation (Loulou et al., 2016). Scenarios are built on least cost and low carbon energy pathways, involving technological innovation, efficiency and RE from fossil and biomass sources. The dynamic of SOC are not usually considered in these types of models (Frank et al., 2015).

For this study, we exported the outputs from the TIMES-MIRET model (Lorne and Tchong-Ming, 2012), over the timeline of the simulation period 2019 to 2050. TIMES-MIRET is a partial-equilibrium model (PEM), also referred as techno-economic model, covering the energy-transport sector of metropolitan France. Further specifications on the model were previously introduced in Albers et al. (2019a).

The TIMES-MIRET calibration is the 2009 EU Directive and National Energy Plan with climate targets by 2020, serving as a reference in the business-as-usual (BAU) policy scenario. BAU is contrasted with new targets by 2030 from the 2015 French Energy Transition for Green Growth Act for the transport sub-sector. The new constraints are 15% renewable energy share in the transport-subsector and maximum 7% 1G biofuels (here analysed with the 15BIO scenario), and in addition to it, 30% fossil fuel reductions and intermediate targets for advanced biofuels (here analysed in the LTECV scenario) (MTES, 2018).

2.1.2 Biomass-to-biofuel commodities and land use

Biomass-to-biofuel pathways, retrieved from the PEM, depend on the policy constraints given to the model. The following biomass commodities flows [kt] were considered: first generation (1G) crop-based starch (wheat, rapeseed, maize and triticale), oil (rapeseed, sunflower and soybean), sugar (sugar beet), as well as second generation (2G) residual lignocellulosic straw (wheat, rapeseed, maize and triticale) and dedicated lignocellulosic perennial grasses (miscanthus and switchgrass as a proxy for dedicated lignocellulosic biomass). Other commodities (e.g. algae, yeast, palm oil, sewage sludge, and spent cooking oil) are excluded due to their comparatively low to null contributions to the overall biofuel transport sector in the three analysed policy scenarios. The biofuel pathways included in this study refer to transport bioethanol and biodiesel.

We computed the LU requirements [$\text{ha}\cdot\text{yr}^{-1}$] in terms of the equivalent agricultural area. Such conversion is based on statistics and literature on agricultural data of potential yields per area [$\text{t}\cdot\text{ha}^{-1}$] revealing the amount of crop product that is exported from the field and the chemical composition of the harvested crop product, determining its starch, sugar or oil contents [%]. Residues (straw) are computed based on the residue yield of the whole plant times the residue removal rate (if any), while dedicated perennials represent 100% of the lignocellulosic commodity. Detailed specification on the computation and methods used for biomass-to-biofuel, LU and GHG emission conversion are provided in the Supplementary Material.

2.2 Dynamic soil organic carbon modelling

We adapted the relatively simple, yet appropriate for modelling dynamic inventories, SOC model of Hénin and Dupuis (1945). The model runs with a time step of one year compatible with the time-dependent climate change characterisation. Hénin and Dupuis' model is based on the interaction of C between two soil compartments: i) fresh organic matter input from AG (crop residues) and BG plant parts (dead roots and rhizomes), as well as exogenous organic inputs (e.g. soil amendments/fertilisers), and ii) the active pool (soil layer up to 30 cm depth) (see Supplementary Material). The C balance represents the difference between the dynamic C input [$t \cdot C \cdot ha^{-1}$] from a flow of organic matter (m) entering the active pool at a given time (t_0), as well as the losses from C output flows (here as CO_2 flows) determined by instant releases determined by the isohumic coefficient (h) and the gradual decay determined by the mineralisation coefficient (k). The model has been developed into a long-term SOC model, referred to as the AMG model (Andriulo et al., 1999), undergoing continuous refinements (latest version introduced in Clivot et al. (2019)). AMG accounts for C stocks in the upper layers (≤ 30 cm) and stable deeper layers (> 30 cm). It has been integrated in the STICS model (Saffih-Hdadi and Mary, 2008) and implemented into the SIMEOS-AMG tool (Bouthier et al., 2014).

For the model coupling (here with an energy model), it is required to assess the technical flows of a product system (here biofuels) for any given calendar simulation year, independent from C stocks or C losses from previous LU or LUC. In contrast to the long-term AMG model, we aim at modelling the added C to the soil given by the technical flows and its time-dynamic decay within the active pool (i.e. the annual difference between the remaining C from a single-year input and the C releases over time until the SOC balance equals zero). Thus, initial stable C stocks from long-term crop cultivation systems associated with the same LU over several consecutive years are not modelled and it is assumed that the stable pool does not change over several centuries (Kwiatkowska-Malina, 2018; Shibu et al., 2006).

The modelling of the soil C balance is computed with Eq. 1, according with Hénin and Dupuis (1945), however fractioning the C input from m into AG (crop residues including exogenous matter) and BG (root system) compartments. The integral for the net annual flows for AG and BG are given in Eq. 2 and Eq. 3 respectively:

$$C_{AP} = C_{AG} + C_{BG} \quad \text{Eq. 1}$$

$$C_{AG}(t_0) = m_{AG}h \quad \text{Eq. 2}$$

$$\frac{dC_{AG}}{dt} = -kC_{AG}$$

$$C_{BG}(t < t_{RL}) = m_{BG} \quad \text{Eq. 3}$$

$$\frac{dC_{BG}}{dt} = \begin{cases} 0, & \text{when } t < t_{RL} \\ -k C_{BG}, & \text{when } t \geq t_{RL} \end{cases}$$

where C_{AP} [$\text{t C}\cdot\text{ha}^{-1}$] is the carbon content in the active pool from AG and BG compartments, m is the added carbon at time t [yr], RL the rotation length [yr], h [unitless] is the humification coefficient, and k [yr^{-1}] the mineralisation coefficient. The rationale behind dividing C_A into AB and BG is the dynamic character of perennial grasses, as the rhizomes remains in the soil in the long-term (i.e. C is stored over the entire cultivation/RL period), while AG residues contribute to annual C inputs (i.e. AG biomass is harvested every year like annual crops) (Beuch et al., 2000). The long-term model, on the other hand, does not allow assessing perennial species (Clivot et al., 2019).

2.2.1 Humification coefficient

The isohumic coefficient h (by some authors also referred to as k_1) represents the ratio between the added SOM contributing to SOC increase and the total amount of the added SOM (Hénin and Dupuis, 1945). It thus represents the fraction of SOM transformed into humified C (i.e. available to plants), while the remaining C is released to the atmospheric pool, via mineralisation (Kwiatkowska-Malina, 2018). High h values mean that the organic matter decomposes easily (e.g. 15% for straw compared with up to 70% for some soil amendments) (Le Villio et al., 2001). For this study, h values and C contents per crop type and EX matter were taken from the literature (Supplementary Material).

2.2.2 Mineralisation coefficient

The initial SOC stock is continuously reduced by mineralisation, over time (i.e. a flow, represented by positive emissions), until the net balance reaches zero. The mineralisation coefficient k (also referred to as k_2 by some authors) represents the annual decay of SOM as GHG emissions, such as CO_2 , and the release of nutrients into plant-assimilable forms, and depends heavily on soil type, soil characteristics, and other pedoclimatic conditions. Saffih-Hdadi and Mary (2008) demonstrated that C mineralisation of crop residues (and by extension of any exogenous organic matter) is driven by the substrate quality rather than by the soil type (under the same humidity and temperature conditions). The C:N ratio also plays a key role in SOM mineralisation (Nicolardot et

al., 2001), but this parameter is not directly used in this model, as its influence is captured in the humification coefficient.

In France, the mean annual mineralisation constant rate is often estimated at 2% (Frisque, 2007; Le Villio et al., 2001; UNIFA, 1998). A review (see the Supplementary Material) of several site-specific studies (with k calibrated to specific locations) indicated a range between 0.7% and 9%, with mean values at 4%. For computing k , the updated method proposed in the AMGv2 model (Clivot et al., 2019), takes under consideration soil mean temperature, clay and calcium carbonate (CaCO_3) contents. Our k estimates excluded soil moisture, pH and C/N ratio, as the scope of the study disregards site-specific parameters, focusing primarily on the C flows. Soil temperature, clay and CaCO_3 content are the key parameters in this study, providing close approximations for a usable mineralisation rate. We computed k for eight climate types in France, referring to the classification by Joly et al. (2010), for which a dominant soil type can be roughly assigned. For the model coupling, we chose climate Type 3 (Central France) featuring a mean temperature of 11°C and mean clay content of 16.8%, as this climate type represents an important agricultural area for cereals and oil crops. For the imported soybean, we used the same method, based on the reference soil temperature of 27°C, representing about 2°C higher for surface soils in soybean cropland in Mato-Grosso, Brazil (Nagy et al., 2018). All specifications are provided in the Supplementary Material.

2.3 Modelling carbon inputs to the soil from aboveground, belowground and exogenous matter

The net C inputs to the soil dependent on management practices defining removal/export rates from the AG compartment (crop products, residues) and BG compartment (rhizomes and roots), as well as the incorporation of non-mineral exogenous matter (organic fertiliser). Therefore, methods were adapted to model the partitioning of C in the different crop fractions, to determine what proportion of AG and BG plant are incorporated in the soil and whether EX matter is added.

2.3.1 Rhizomes growth and carbon fixation of perennial grasses

Dynamic growth and carbon sequestration of annual crops are commonly excluded from dynamic carbon modelling, as their C fixation and release flows occur within one year, equivalent to carbon neutrality (Guest et al., 2013). The same applies to the AG perennial grasses, harvested annually. However, growth dynamics of the BG biomass fraction require an additional modelling step, given that the C fixation in the rhizomes occurs over several years, in contrast to annual crops.

We considered the miscanthus (*Miscanthus x giganteus*) and switchgrass (*Panicum virgatum*), which are perennial rhizomatous C4 grasses. These grasses have extensive root systems, which may increase in the long-term (Agostini et al., 2015). However, dynamic growth models for root system are not accessible, as they tend to be very complex and species-specific (Dupuy et al., 2010). A meta-analysis by Agostini et al. (2015) highlighted that the biomass growth from the BG compartment and the C inputs to the soil are mainly based on several

Chapter 5: Agriculture: Soil organic carbon modelling

single observations with variable stand age, depths and sampling frequencies, making it difficult to model the time series of the root system. Yet, it has been demonstrated that the C fixation increase with increasing cultivation period (Arevalo et al., 2011; Rehbein et al., 2015).

Rehbein et al. (2015) calculated the miscanthus-derived C for different soil depths/layers up to 100 cm and showed that the C stock increased linearly with increasing time ($R^2 = 0.8$, $P < 0.001$) in the top soil (≤ 10 cm) and deeper soil layers (0-100 cm), whereas 60 to 80% of the C is associated to the top soil. Based on the results from Rehbein et al. (2015) and meta-analysis from Agostini et al. (2015), we distributed the total C over the entire rotation length linearly to represent the rhizomes growth and C fixation in the biomass. Consequently, the time-dependent CBG inputs to the soil (Eq. 3) from miscanthus and switchgrass take place after the end of the rotation length at 20 and 15 years respectively. Both C fixation and SOC release flows are allocated accordingly.

2.3.2 Plant fractioning and carbon partitioning

For computing the C inputs to the soil from AG and BG compartments, the approach of Bolinder et al. (2007), applied in other studies (Clivot et al., 2019; Wiesmeier et al., 2014), was adopted. The authors conceptualise the C input to the soil as a proportion of net primary productivity (NPP), summing up four plant fractions per unit of area [$t\ C \cdot ha^{-1}$]:

- C_P : the C in the agricultural product (P) in the AG (e.g. seed, grain, perennial grasses, and forage crops) or BG (e.g. tuber) compartments, representing the primary economic value, not incorporated into the soil.
- C_S : C in the residual (S) AG fraction (e.g. straw, stover) incorporated into soil after harvest.
- C_R : C in root (R) tissue (rhizome) in the BG, physically recoverable plant materials (excluding products such as tuber from sugar beet), mostly incorporated in the soil after harvest.
- C_E : C in extra-root (E) matter (rhizome deposition), involving root exudates and plant materials physically not easily recoverable, mostly incorporated in the soil after harvest.

C partitioning per plant fraction and per crop follows the method from Bolinder et al., (2007), including data from the literature (mean annual yield per crop and relative C allocation coefficients), both presented in the Supplementary Material. The C inputs to the soil depend on the annual yield estimates at field scales, obtained from statistics and literature. These values can be adapted to site-specific evaluations.

2.3.3 Estimation of exogenous inputs

Exogenous C inputs consist of added organic matter, under the form of amendments and fertilisers (Saffih-Hdadi and Mary, 2008). Based on French statistics on crop production (surfaces, yields) and organic fertiliser use (AGRESTE, 2019, 2014, 2011), as well as on the composition of French organic fertilisers (Avadí, 2019),

average French fertilisation practices for each crop of interest were constructed. For Brazilian soybean, data was retrieved from FAO (2004).

2.3.4 Variations of carbon inputs to the soil

Not all the C embedded in plant fractions is returned to the soil. The net C inputs from AG, BG and EX matter depend on agricultural management practices. Consequently, four different scenarios are analysed and contrasted in this study, which could eventually be associated with residue management practices:

- Scenario S1_TOT: Total C inputs to soil (aboveground + belowground + exogenous carbon)
- Scenario S2_AG: C from aboveground plant residues
- Scenario S3_BG: C from belowground plant residues
- Scenario S4_EX: C from exogenous matter

The resulting scenarios are based on the origin of C from different plant fractions (AG and BG) and EX matter, whereas S1_TOT represents the sum of all added C to the soil. These scenarios represent highly contrasted extremes of management practices. In reality, these practices are likely to be more nuanced (e.g. partial combinations of AG, BG, EX added to the soil). The high contrast allows identifying the origin of C and their proportional contributions to the total SOC input.

We assumed that the total Cp is harvested. However, CS, CR and CE inputs are adjusted with correction factors ranging between 0 (no C input) and 1 (100% C input) to specify the C plant proportion added to the soil (more details provided in the Supplementary Material). In France, common CS removal rates from cereals and oily seeds are in the order of 0.5, while for vegetables, protein crops and perennials they are in the order of 1, whereas CS from switchgrass is zero (ADEME, 2017). CR and CE are assumed to be wholly incorporated into the soil (except for sugar beet root, which is exported from the fields).

3 Results and discussion

3.1 Policy scenario simulations from the partial-equilibrium with static GHG emissions

Fig. 2 shows a comparative overview of the three analysed policy scenarios (BAU, 15BIO and LTECV) of the transport sub-sector from 2019 to 2050, analysed with the PEM, denoting LU requirements [ha], biomass commodity supply [kt], final energy supply [MJ], and associated GHG emissions [kt CO₂-eq] of the simulations represent the pathways of bioethanol and biodiesel demand only.

A general comparison among the three policy scenarios shows a clear shift from 1G to 2G energy carriers for the transport sub-sector, particularly evident for the LTECV scenario. The shifting energy-pathways reduce the overall resource consumption and LU demand, particularly for 1G energy crops, that consequently reduce the GHG emissions to meet the mitigation targets. It is noticeable that the prospective evaluations assume increased number of passengers per km driven per transport means, and thus reduced future fuel demand. The 15BIO

Chapter 5: Agriculture: Soil organic carbon modelling

scenario shows sudden increases between the years 2030 and 2040, responding to the constraint of limiting 1G share to 7% from 2020, remaining effective in the 2030s, concerning the multi-annual energy program in the transport sector. The scenario simulations return to a new equilibrium, as no further constraints are specified for advanced biofuels, yet the values remain under BAU evaluations. In contrast, LTECV takes into account all policy constraints from the French law for the transport sub-sector, such as intermediate targets for advanced biofuels and 30% reduction of fossil fuels in the final net energy share.

Results for LU requirements (Fig. 2a), reveal the equivalent agricultural area requirements associated with the biomass commodity supply of 1G and 2G transport biofuels. A comparison with BAU, shows that while LU for 1G decrease, they increase for 2G due to the shifting energy pathways towards more advanced biofuels. Yet, the overall LU decreases per policy scenario with 50%, 41% and 9% for BAU, 15BIO and LTECV respectively. The proportion of the derivative commodities (starch, sugar, oil) to the equivalent harvested energy crop yields vary considerably between 18% and 64%, and therefore represent higher equivalent agricultural area demand, compared with the residual and dedicated lignocellulosic commodities.

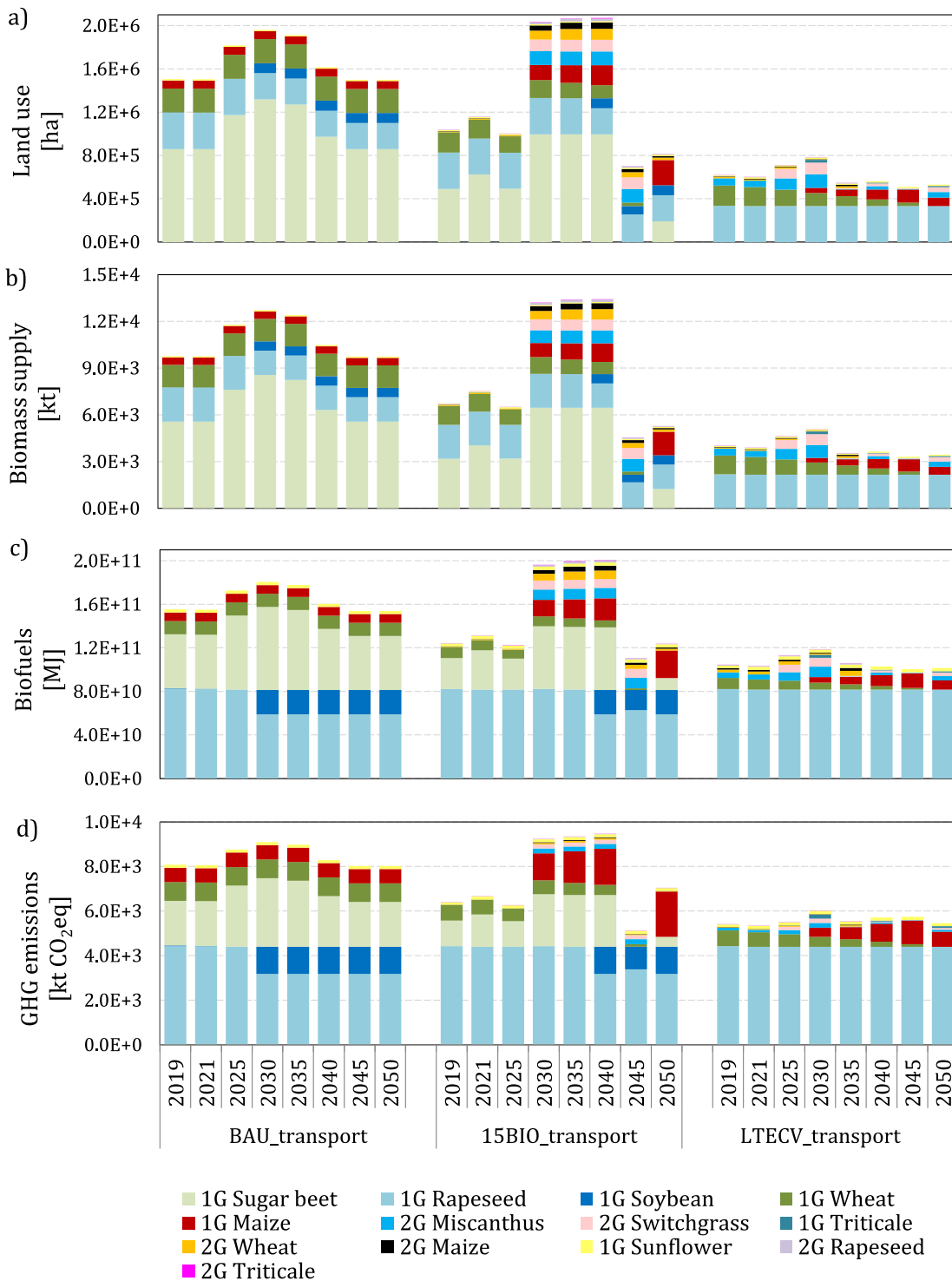

Fig. 2. Policy scenario simulations (BAU, 15BIO, LTECV) linked with first (1G) and second (2G) generation bioethanol and biodiesel pathways in terms of a) land use requirements in ha, b) biomass commodity supply in kt, c) equivalent energy supply in MJ, and d) associated Greenhouse Gas emissions in kt CO₂-eq

The biomass commodity supply (Fig. 2b) in the BAU policy —which does not follow the multi-annual energy program for the transport sub-sector— accounts for dedicated 1G annual crops only, dominated by sugar beet

Chapter 5: Agriculture: Soil organic carbon modelling

(60%), rapeseed (17%), and wheat (13%). 15BIO policy increases the 2G-share by 15%, yet sugar beet (44%), rapeseed (22%) and wheat (9%) remain the main supply sources. The LTECV policy further increased the 2G-share up to 17%, of which perennial grasses (miscanthus and switchgrass) contribute to 90%. 1G soybean and 1G sugar beet would be displaced completely; yet 1G rapeseed (55%) and wheat (17%) will remain the main supply sources.

The net final energy supply (Fig. 2c) represents the bioethanol and biodiesel yield per dry matter of the commodity. Conversion efficiencies vary strongly among the different renewable energy carriers, whereby oleaginous crops have higher yield efficiencies. The main contributor to the net biodiesel supply will increasingly be rapeseed oil with up to 41%, 49% and 77% for BAU, 15BIO and LTECV respectively, and for bioethanol sugar beet with up to 36% and 23% in BAU and 15BIO respectively (yet 0% for LTECV). With the upcoming technological innovation for advanced biofuels, LTECV scenarios showed that advanced biofuels (involving synthetic biofuels) will play a major mitigation role, with up to 10% share in the net final energy.

The GHG emission estimates (Fig. 2d) linked with fossil fuels only are based the EC JRC well-to-wheel method (Edwards et al., 2014), for bioethanol and biodiesel and the static IPCC GWP metric. The highest mitigation targets are achievable by means of the LTECV scenario. All emissions in the BAU scenario derive from 1G biofuels, whereas 4% and 3% originate from 2G in 15BIO and LTECV respectively. 1G source are the main contributors to GHG emissions, particularly rapeseed oil (up to 43%, 53% and 73% for BAU, 15BIO and LTECV respectively) and sugar beet (up to 28% and 19% in BAU and 15BIO respectively). The lower impact contributions from 2G biofuels are due to reduced emission factors in g of CO₂eq·MJ⁻¹, as compared with conventional fuels and 1G biofuels.

3.2 Parameters for soil organic carbon computation

Table 2 provides an overview of data and coefficients used to compute the C inputs to the soil, associated with crop C content, humification coefficients, yields, carbon partitioning per relative plant fraction, NPP, and exogenous inputs, per ha, at field scales. C fractioning among plant parts and C partitioning from NPP are calculated here from annual yield estimates at field scales, per ha. For miscanthus, for which few data is available, dry matter yields range between 16.1 and 28.5 in France (AGRESTE, 2019; Strullu et al., 2014) and globally between 14.8 and 33.5 (Rehbein et al., 2015). We used the mean 22.8 t DM ha⁻¹ based on measured values by Strullu et al. (2014). EX matter represents mean French agricultural practices regarding fertilisation of cultivation of energy crops. The mineralisation coefficients resulted in 0.1176 for French cereals and oily seeds and 0.0733 for Brazilian soybean, based on the regional mean temperature estimated at 25°C and a clay content of about 43%. The computation, underlying data and assumptions are further detailed in the Supplementary Material.

Table 2. Isohumic coefficient (h), carbon (C) content, carbon partitioning from net primary productivity (NPP), and mean French agricultural practices regarding fertilisation of energy crops and exogenous inputs

Crops and residues	Yields [t·ha ⁻¹]	Isohumic coefficient (h)	C content	Carbon partitioning per plant fraction (calculated)				NPP [kg ha ⁻¹]	Fertilisation of cultivation of energy crops N effluents						
				C _P [t C·ha ⁻¹]	C _S [t C·ha ⁻¹]	C _R [t C·ha ⁻¹]	C _E [t C·ha ⁻¹]		Mineral [t·ha ⁻¹]	Cattle [t·ha ⁻¹]	Poultry [t·ha ⁻¹]	Swine Compost [t·ha ⁻¹]			
Maize	11.980 a	0.193 e	0.414 i	4.957	5.369	2.959	1.967	15.251	1	133	11.069	0.519	1.513	1.410	nr
Rapeseed	3.655 a	0.244 f	0.502 i	1.901	10.231	3.393	2.238	17.763	1	169	3.989	0.187	0.545	0.508	nr
Wheat	6.408 a	0.193 f	0.475 i	3.046	4.354	1.697	1.124	10.220	1	169	0.819	0.038	0.112	0.125	nr
Triticale	5.501 a	0.125 e	0.475 i	2.615	5.088	1.428	0.925	10.056	1	107	5.265	0.247	0.720	0.671	nr
Sunflower	2.720 b	0.200 e	0.440 i	1.197	1.795	0.330	0.000	3.322	1	123	2.843	0.133	0.389	0.362	nr
Sugar beet	9.540 b	0.126 e	0.467 i	4.459	0.245	0.245	0.164	5.114	1	56	9.516	0.446	1.301	1.212	nr
Soybean	3.479 c	0.230 g	0.440 j	1.531	2.291	0.735	0.478	5.035	1	8	0.000	0.000	0.000	0.000	nr
Miscanthus	22.788 d	0.126 f	0.475 j	10.835	12.218	12.995	4.332	40.379	1	52	1.505	0.071	0.206	0.192	nr
Switchgrass	15.714 a	0.126 e	0.497 k	7.805	0.000	5.451	3.54	16.796	1	65	0.983	0.046	0.134	0.125	nr
Cattle effluents	N/A	0.558 h	0.055 k	N/A	N/A	N/A	N/A	N/A	N/A	N/A	N/A	N/A	N/A	N/A	N/A
Poultry effluents	N/A	0.308 h	0.154 k	N/A	N/A	N/A	N/A	N/A	N/A	N/A	N/A	N/A	N/A	N/A	N/A
Swine effluents	N/A	0.462 h	0.083 k	N/A	N/A	N/A	N/A	N/A	N/A	N/A	N/A	N/A	N/A	N/A	N/A
Other soil amendments (proxy compost)	N/A	0.670 h	0.130 k	N/A	N/A	N/A	N/A	N/A	N/A	N/A	N/A	N/A	N/A	N/A	N/A

Sources: a (AGRESTE, 2019), b (Besnard et al., 2014), c (Cattelan and Dall'Agnol, 2018), d (Strullu et al., 2014), e (Duparque et al., 2013; Irizar et al., 2015; Moreno et al., 2016; Saffih-Hdadi and Mary, 2008), f (UNIFA, 1998), g (Irizar et al., 2015; Moreno et al., 2016), h (Agro-Transfert, 2019; Bouthier et al., 2014), i (PHYLLIS 2 database, 2019), j (Ma et al., 2018), k (Avadi, 2019), l (Bolinder et al., 2007; Carvalho et al., 2017; Richter et al., 2016; Strullu et al., 2014), for miscanthus aboveground inputs between 40% and 67% (Carvalho et al., 2017; Strullu et al., 2014) and perennial belowground proportions of rhizomes 75% and roots 25% (Agostini et al., 2015), m (AGRESTE, 2019, 2014, 2011; Avadi, 2019; FAO, 2004). "Effluents" refers to average values from manures, slurries and droppings (poultry). Modelling details of specific crops: maize (as a mean of grain and fodder), miscanthus (as permanent prairie), switchgrass (as temporary prairie), wheat (as a mean of hard and soft). Descriptions of sub-indices: P - agricultural aboveground product, S - residual aboveground compartment, R - root/rhizome tissue, E - extra-root material.

3.3 Carbon inputs to the soil

Fig. 3 shows the relative C added to the soil per energy crop in proportion to the AG and BG plant fractions, as well EX matter. The C inputs vary considerably among the different energy crop types, yet BG and AG have highest contributions to SOC, as compared with organic fertilisers.

In this study, the comparatively higher C contributions are associated with BG (Fig. 3), ranging (from smaller to higher) between 20% and 30% for sunflower and sugar beet, between 35% and 45% for soybean and triticale, between 50% and 60% for rapeseed, wheat, maize and miscanthus, and up to 100% for switchgrass. Switchgrass has no residues (except for a disregarded minor amount of stubble), while the AG proportion of other crop types range between 16% and 31% for sugar beet and maize, between 40% and 50% for miscanthus, wheat, rapeseed and triticale, and the highest contribution from sunflower (60%) and soybean (65%). The remaining proportions associated with EX is rather low, yet with considerable differences per crop type, highest for sugar beet (57%), sunflower (17%), maize (12%) and triticale (9%). Note that the inputs are rather case- and site-specific, management practices may involve higher EX inputs due to displacement of inorganic fertilisers or higher/lower removal rates for AG/BG matter

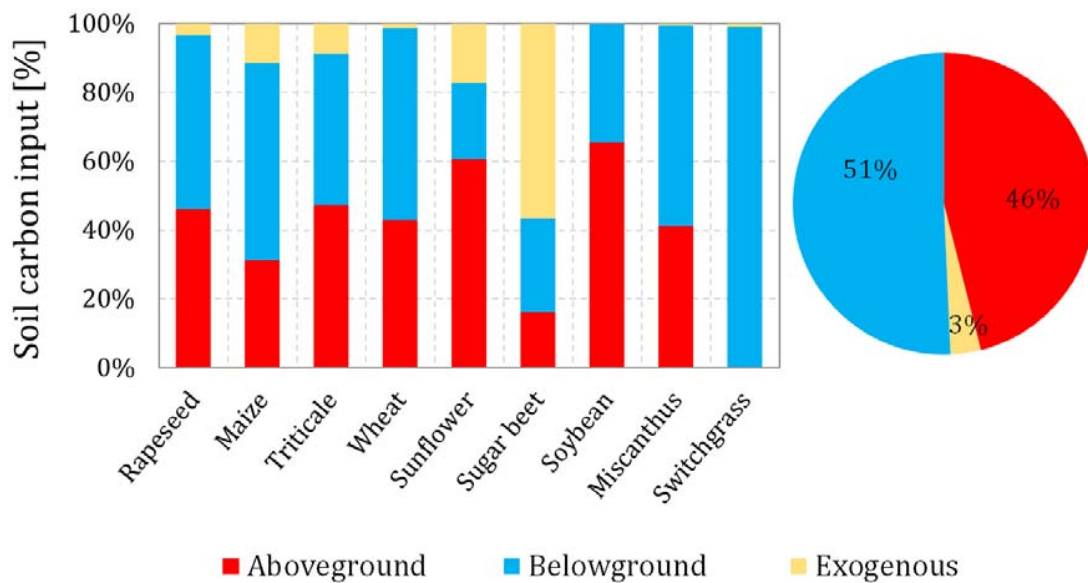

Fig. 3. Soil carbon inputs per biomass commodity from above- and belowground plant compartments, including exogenous matter. Pie chart represents the average proportions

Fig. 4 shows the dynamic SOC inventories associated with policy and C input scenarios. It represents the dynamic elementary flows resulting from the coupling with the PEM biomass commodity outputs (technical flows) per policy scenario, i.e. BAU (Fig. 4a), 15BIO (Fig. 4b) and LTECV (Fig. 4c). The flows are expressed in

t CO₂ according to the C content in the compound (44/12 g CO₂.g⁻¹). Other GHG emissions from decay, such as methane, are not accounted for, but should be considered in future studies.

The net annual SOC balance adds up all C inputs (negative values) per simulation year and the subsequent gradual releases (positive values) from decay of all previous and consecutive years. The end-year 2050 shows an “artificial cut-off” due to the ending of the prospective assessment of the PEM with no further biomass mobilisation. Therefore, the year 2050 reveals peaking positive values.

For this study, the selected TH projects the last year of the PEM simulation period over an additional century, that is to say from 2050 to 2150. The TH generally defines the length of time over which the GHG emissions are integrated (Levasseur et al., 2016) (in static methods fixed to 20 or 100 years), however is flexible in dynamic LCA (Levasseur et al., 2010) and can be adapted to any dynamic inventory TH, as discussed in (Albers et al., 2019b). The determination of a TH remains subjective, as no theoretical foundation has been identified, but only a political one (the widely accepted IPCC 100 years TH). The chosen TH over 100 years is valid here for the SOC inventory flows as well as for the subsequent impact assessment. The temporal cut-off for SOC inventories at year 2150 is justifiable: after the first century, the remaining SOC-sourced CO₂ range between 6E-5 and 4E-5, assuming here at the given TH that an equivalent zero net C balance is reached (i.e. carbon neutrality). The first SOC input in the year 2019 represents the highest SOC sequestration potential, decreasing with increasing inventory time horizon (LCI TH).

A comparison among variations of TIMES-MIRET scenarios featuring the origin of different C inputs denotes a particular SOC dynamic associated with S3_BG in 15BIO and LTECV. Note that S3_BG has a longer sequestration curve and extended release flows, as compared with the S2_AG and S4_EX contributions. This phenomenon relates with the perennial grasses introduced for advanced biofuels to respond to the new policy constraints. This type of energy crop involves biomass growth and carbon fixation dynamic of rhizomes during the rotation length. Moreover, the proportions of the AG and BG SOC flows (S2_AG and S3_BG) in the first inventory year 2019, demonstrated that the two input variations contribute to SOC in similar proportions for BAU (32% and 38%, 15BIO (36% and 41%) and LTECV (44% and 49%). In contrast, S4_EX considerably decreases for 15BIO (22%) and LTECV (7%) compared with BAU (29%). The cumulative sum of all C inputs (referring to S1_TOT) represented SOC contributions of about 40%, 34%, and 26% for BAU, 15BIO and LTECV scenarios respectively.

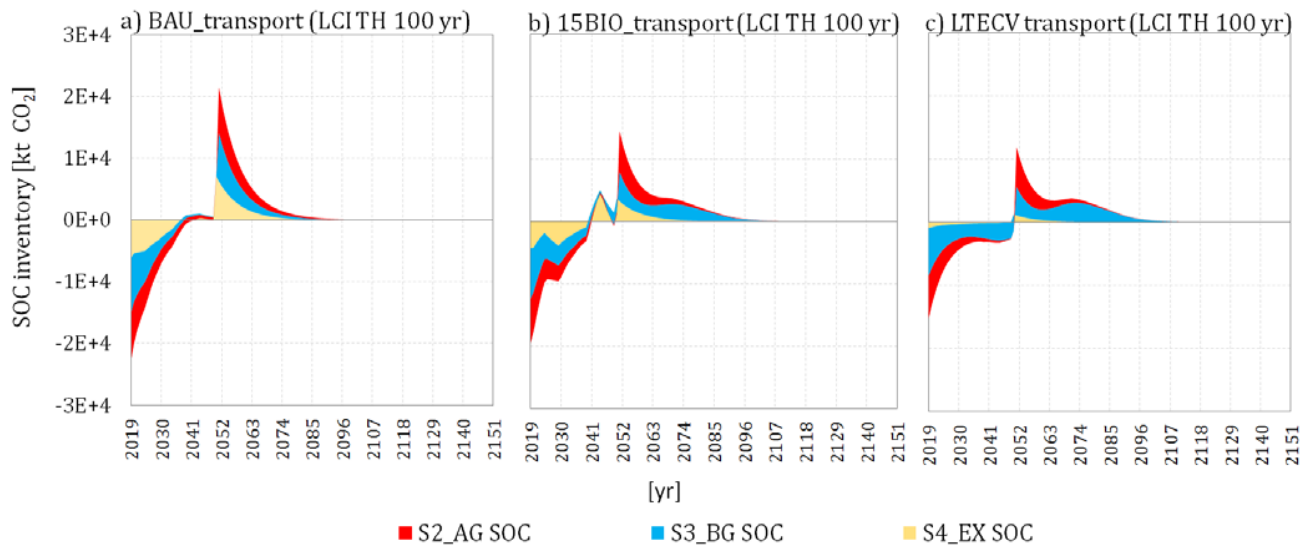

Fig. 4. Soil organic carbon inventories over a time horizon of 100 years [kt CO₂] per TIMES-MIRET (BAU, 15BIO, LTECV) and C input (S2_AG, S3_BG, S4_EX) scenarios

3.4 Dynamic impact assessment: Radiative forcing effects per policy and management scenario

Fig. 5 shows the instantaneous [in W·m⁻²] and cumulative [W·yr·m⁻²] radiative forcing (RF) effects per policy and C input scenarios over a 100-year LCIA TH. The 100-year reference is recommended by the IPCC guidelines (Myhre et al., 2013) and most commonly used in LCA, yet any future reference year could be chosen with dynamic LCA (Levasseur et al., 2016, 2010). The RF effects are given for SOC (i.e. biogenic-sourced), C-neutral (i.e. fossil-sourced), as well as the C-complete (i.e. SOC + C-neutral). The overall results show considerable variations between C-neutral and C-complete effects, due to SOC accounting.

Instantaneous RF (Fig. 5a, b, and c) refers to the GHG concentrations and their induced net concentration change (Myhre et al., 2013). It allows describing the net changes through time. The “artificial cut-off” at year 2050 is evident. For SOC emissions, it means that no further inputs are computed and therefore the positive emissions outweigh the negative ones until equilibrium is reached and all emissions are returned back to the air (referred here as a net zero C-balance). The annual cumulative RF effect (Fig. 5d, e, and f) of a pulse emission is given by integrating the instantaneous forcing, allowing a direct comparison among scenarios. Firstly, it is identifiable that the C-neutral effects are considerably lower for LTECV than for BAU and 15BIO. It reveals that the constraints lead towards higher climate mitigation targets. Secondly, the annual negative effects from SOC-CO₂ flows further reduce the C-neutral results in all analysed policy scenarios within the first century, contributing to climate mitigation. The mitigation is higher for S3_BG (and consequently S1_TOT) in 15BIO (Fig. 5b) and LTECV (Fig. 5c).

A quantitative comparison of the cumulative RF of C-neutral and C-complete results per policy scenario can only be undertaken by selecting an end-year of the impact assessment (reference year), here 2150. The C-neutral results of 15BIO ($2.5E-8 \text{ W}\cdot\text{yr}\cdot\text{m}^{-2}$) and LTECV ($1.8E-8 \text{ W}\cdot\text{yr}\cdot\text{m}^{-2}$) show reduced forcing effects by about 10% and 34% respectively compared with the BAU reference ($2.8E-8 \text{ W}\cdot\text{yr}\cdot\text{m}^{-2}$). The accounting of SOC flows further reduce the cumulative RF effects, as highlighted with C-complete results. S1_TOT (S2_AG + S3_BG + S4_EX) represents the highest reduction potentials for 15BIO ($2E-8 \text{ W}\cdot\text{yr}\cdot\text{m}^{-2}$) and LTECV ($1.4E-8 \text{ W}\cdot\text{yr}\cdot\text{m}^{-2}$) versus BAU ($2.5E8 \text{ W}\cdot\text{yr}\cdot\text{m}^{-2}$), whereof 50% and 65% are BG contributions given in 15BIO and LTECV scenarios respectively (see also the Supplementary Material).

However, SOC benefits decrease with increasing LCIA TH, that is to say, the more into the future the reference end-year is set, the lower are the contributions to climate mitigation. Firstly, this is due to the artificial cut-off associated to the PEM analysis. Secondly, in the long-term (beyond a 100-year LCIA TH), all SOC-sourced CO₂ emissions converge to equilibrium, reaching a steady state, as all emissions return to the air. Yet, without the consideration of SOC emissions, the negative RF (cooling effects), and thus the temporary climate benefits, are not account for, leading to biased net C balance results over time..

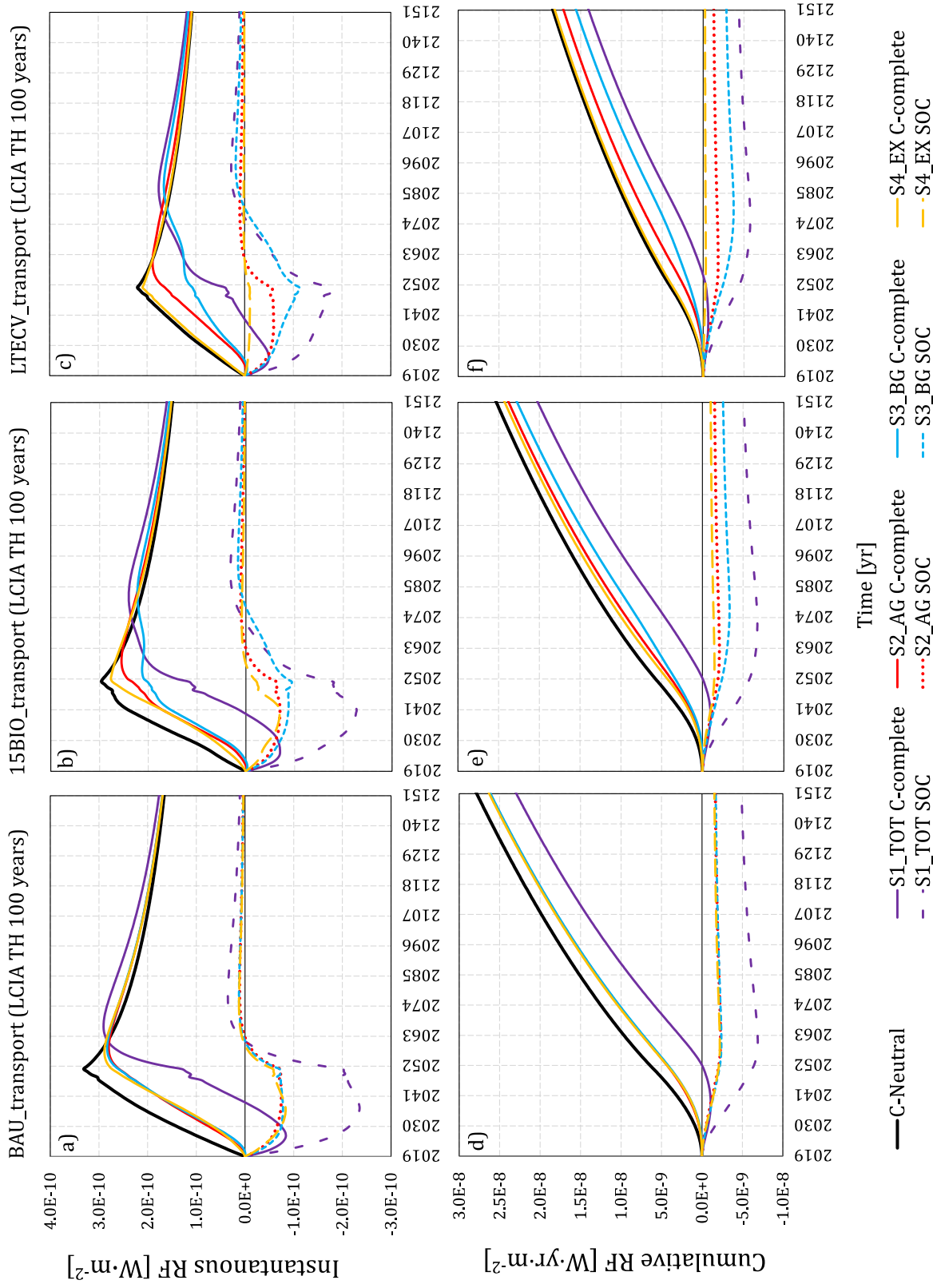

Fig. 5. Instantaneous [W·m⁻²] and cumulative [W·yr·m⁻²] radiative forcing per policy (BAU, 15BIO and LITECV) and C input (S1_TOT, S2_AG, S3_BG, S4_EX) scenarios, denoting the dynamic impacts from biogenic- (here SOC flows) and fossil- (C neutral) sourced emissions, as well the sum of both in C-complete

The forcing contribution of the different SOC compartments become more evident by taking a closer look into the cumulative RF effect of AG (Fig. 6a), BG (Fig. 6b) and EX (Fig. 6c) per policy constraint. The highest contributions to climate mitigation are associated with S3_BG in both 15BIO and LTECV, reducing BAU by 150% and 170% respectively. This is due to biomass growth of rhizomes of perennial grasses that are not incorporated into the soil until the end of the rotation length, and thus represent temporal C-stock delaying degradation emissions. Consequently, the temporary sequestration and storage has climatic benefits due to postponement of positive RF (warming effects). The negative RF effects from perennial grasses and their derivative biofuels may represent a better alternative to annual crops in terms of climate change mitigation.

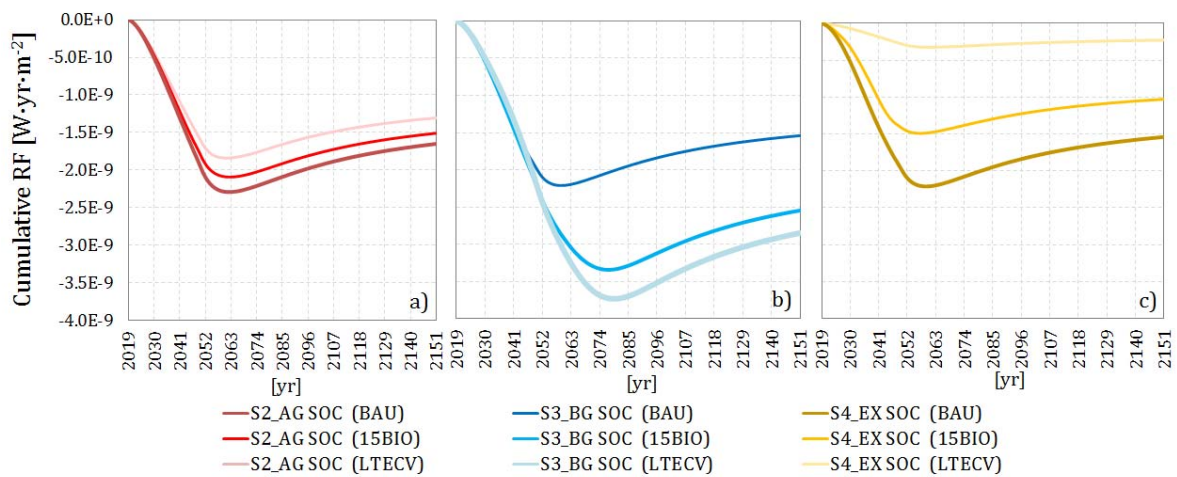

Fig. 5.2. Cumulative radiative forcing [$\text{W}\cdot\text{yr}\cdot\text{m}^{-2}$] per policy (BAU, 15BIO and LTECV) and C input (S2_AG, S3_BG, S4_EX) scenarios

3.5 Sensitivity analysis

We conducted a sensitivity analysis for the LTECV policy scenario concerning i) the SOC model k coefficient (uncertainty due to site-dependent pedoclimatic conditions), and ii) the C inputs to the soil (variations in residue removal rates from the field). Therefore, k for type 3 pedoclimatic conditions were recalculated, assuming a temperature increase of 2°C (referred to as SOC $K+2^\circ\text{C}$) due to climate change, resulting in 0.1485, similar to k for oceanic climate type 5. k for SOC $K+2^\circ\text{C}$ in Brazil is 0.0924, yet soybean is excluded in the LTECV simulations. The removal rates concerned the S2_AG compartment (and consequently S1_TOT), for which we run the SOC simulations, assuming two variations equally applied to all energy crops, namely 90% (referred to as SOC_AG 90%) and 10% (referred to as SOC_AG 10%) C input to the soil.

The cumulative RF results from 2019 to 2150 (in Fig. 7a), demonstrate significant variations between model parameter and C input to the soil. A quantitative comparison at year 2150 (in Fig. 7b) per C input scenario, shows a difference between the original values and SOC $K+2^\circ\text{C}$ results by 122%,

127%, 119% and 127% for S1_TOT, S2_AG, S3_BG, and S4_EX respectively. Two major interpretations are drawn. Firstly, SOC benefits decrease with increasing temperature (climate change), because the decay rate increases with temperature and thus C releases to the atmosphere occur over a shorter TH. Secondly, exogenous inputs (S4_EX) are more affected by temperature changes, because they already have high h values and thus lower initial SOC. Regarding the C input variations from SOC_AG residues at year 2150 (in Fig. 7c) S1_TOT original values increase with SOC_AG 90% (due to S2_AG benefit contribution by almost 60%) and decrease with SOC_AG 10% (due to S2_AG deficit contributions by about 500%). Fig. 7b and c additionally show the minimum attainable values, representing the peak sequestration potential attributable to the year 2074 (Fig. 7a). This sensitivity is given due to the selected end-year 2150, which results in lower climatic benefits than the year 2074, linked with the artificial cut-off of the PEM simulation at year 2050

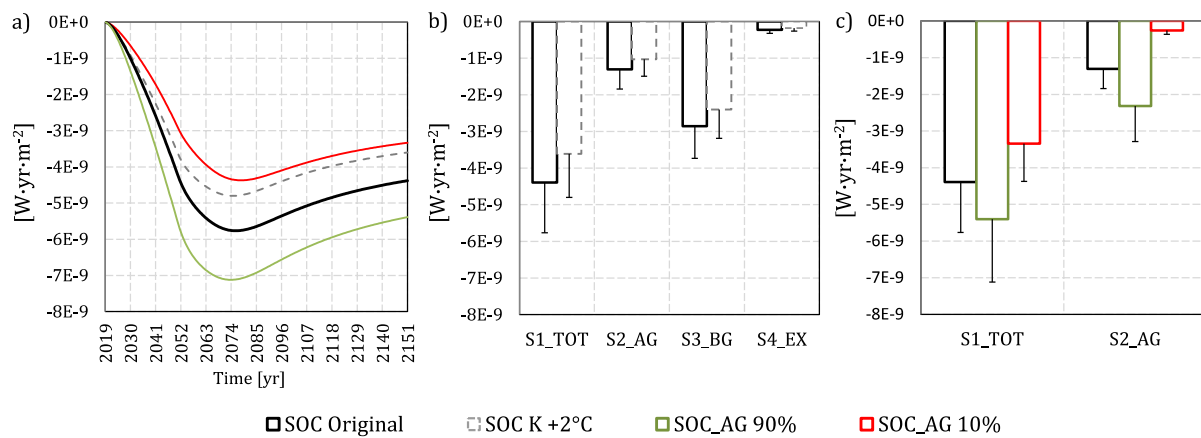

Fig. 7. Cumulative radiative forcing [W·yr·m⁻²] from the sensitivity analysis results a) over the time horizon 2019 to 2119, b) quantitative uncertainty concerning k coefficient and temperature variations, and c) effect from changes in C inputs. b) and c) represent the year 2019 including uncertainty (error bar represent the minimum attainable value)

The variations of residue removal rates have significant consequences on the LU requirements (see Sensitivity analysis on LU in the Supplementary Material). The residue removal rate for energy is an important consideration, as it defines the equivalent agricultural area requirements to meet the energy demand of 2G biofuels. SOC_AG 90% represent minimum and SOC_AG 10% maximum values in terms of residue export from the fields and the inverse for C inputs to the soil. The higher the residue removal rate for energy the higher per unit of area demand: for SOC_AG 10% (i.e. 90% removal rate) LU requirements increase by a factor of 5, while for SOC_AG 90% (i.e. 10% removal rate) decrease by a factor of 0.56. Consequently, trade-off results for the same unit of energy [MJ] produced between higher removals rates versus climate benefits from C inputs to the soil. Note that other relevant factors (e.g. effects on biodiversity, N-mineralisation, yields) —not considered in this study— may play an essential role.

3.6 Limitations of the proposed approach

The coupling framework is generic enough to be used in combination with any demand model or life cycle inventory; however, other essential soil quality indicators and impacts from LUC are not included in the proposed SOC modelling approach. The dynamic of these indicators (e.g. the set of indicators included in LANCA) also needs to be developed to improve the results from soil activities modelling.

Furthermore, it is encouraged to use primary data when available to reduced uncertainties from averaged values. The use of secondary data or parameters may compound the overall (data + model) uncertainty, yet it can be in principle be reduced by data processing and model calibration. Model calibration in particular, which implies the selection of starting values (even for primary data), may nonetheless be biased, and thus self-starting models may be used to find initial conditions for the main models, or, even better, observations data should be used if available.

Data processing should aim to improve the statistical representativeness and coherence of the data. The presented SOC model could be replaced by or combined with alternative models with different model structure, or contrasted with other models, for ultimately more robust findings and low uncertainty in predicting C dynamics in the soil (Shi et al., 2018).

4 Conclusions

The overall comparison among the policy and C input scenarios to the soil shows achievable climate mitigation targets in the transport sub-sector by means of shifting 1G-biomass share towards 2G (advanced) biofuels, particularly given the LTECV policy. Dynamic SOC accounting makes a considerable difference in the C-complete assessment. Without its modelling, temporary mitigation is ignored, thus biasing GHG emission results. Highest mitigation contributions are attributed to perennial grasses, further delaying radiative forcing due to C sequestration in the rhizomes fraction during the entire rotation length. Yet, cooling effects from SOC decrease with increasing LCIA TH, as all emissions return to the atmospheric pool in the long-term. A sensitivity analysis confirmed the SOC variability due to temperature (+2°C increase) and residue removal rates changes. Both affect climate mitigation and the latter also LU by a factor of -0.56 to +5. In the context of LCA, the consideration of other direct and indirect impacts associated with changes in LU, management (e.g. tillage and land preparation, fertiliser use, crop and yield protection, erosion measures) and LUC, including biodiversity should follow suit to better understand trade-offs.

Acknowledgements

The authors would like to acknowledge the support by IFP Energies nouvelles, division of Economics & Technology Intelligence. This work was financed by a doctoral grant as part of the Ph.D. research project of Ariane Albers.

References for Paper 3

- ADEME, 2017. Mobilisation de la Biomasse Agricole : état de l'art et analyse prospective. ADEME, Deloitte Développement Durable, Association d'Initiatives Locales pour l'Energie et l'Environnement (AILE), Alterra Wageningen. Angers. France.
- Agostini, F., Gregory, A.S., Richter, G.M., 2015. Carbon Sequestration by Perennial Energy Crops : Is the Jury Still Out ? *Bioenergy Res.* 1057–1080. <https://doi.org/10.1007/s12155-014-9571-0>
- AGRESTE, 2019. Agreste - Données en ligne [WWW Document]. Ministère de l'Agriculture et de l'Alimentation. URL <https://stats.agriculture.gouv.fr/disar-web/disaron/!searchurl/searchUiid/search.disar> (accessed 2.1.19).
- AGRESTE, 2014. Enquête sur les pratiques culturales 2011: Principaux résultats, Ministère de l'Agriculture, de l'Agroalimentaire et de la Forêt. Agreste les Dossiers No. 21. Montreuil Sous Bois Cedex, France.
- AGRESTE, 2011. Statistique Agricole Annuelle 2010 No 25, Direction Régionale de l'Alimentation de l'Agriculture et de la Forêt. Service Régional de l'Information Statistique et Economique. Rennes Cedex, France.
- Agro-Transfert, 2019. SIMEOS-AMG -Guide Utilisateur: Gérer l'état organique du sol dans les exploitations agricoles. Agro-Transfert Ressources et Territoires, INRA, Arvalis et Terres Inovia. France.
- Albers, A., Collet, P., Lorne, D., Benoist, A., Hélias, A., 2019a. Coupling partial-equilibrium and dynamic biogenic carbon models to assess future transport scenarios in France. *Appl. Energy* 239, 316–330. <https://doi.org/10.1016/j.apenergy.2019.01.186>
- Albers, A., Collet, P., Benoist, A., Hélias, A., 2019b. Back to the future : Dynamic full carbon accounting applied to prospective bioenergy scenarios. *Int. J. Life Cycle Assess.* [under Rev. 1-27].
- Andrén, O., Kätterer, T., 1997. ICBM: The introductory carbon balance model for exploration of soil carbon balances. *Ecol. Appl.* 7, 1226–1236. <https://doi.org/10.2307/2641210>
- Andriulo, A., Mary, B., Andriulo, A., Mary, B., 1999. Modelling soil carbon dynamics with various cropping sequences on the rolling pampas. *Agronomie* 19, 365–377. <https://doi.org/10.1051/agro:19990504>
- Arevalo, C.B.M., Bhatti, J.S., Chang, S.X., Sidders, D., 2011. Agriculture , Ecosystems and Environment Land use change effects on ecosystem carbon balance : From agricultural to hybrid poplar plantation. *"Agriculture, Ecosyst. Environ.* 141, 342–349. <https://doi.org/10.1016/j.agee.2011.03.013>
- Avadí, A., 2019. Screening LCA of French organic amendments and fertilisers. *Int. J. Life Cycle Assess.* [under Rev.].
- Beck, T., Bos, U., Wittstock, B., Baitz, M., Fischer, M., Sedlbauer, K., 2010. LANCA- Land Use Indicator Value Calculation in Life Cycle Assessment – Method Report. Fraunhofer Institute for Building Physics and University of Stuttgart. Echterding.
- Benbi, D.K., Richter, J., 2002. A critical review of some approaches to modelling nitrogen mineralization. *Biol. Fertil. Soils* 35, 168–183. <https://doi.org/10.1007/s00374-002-0456-6>

- Benoist, A., Bessou, C., 2018. Prise en compte en analyse de cycle de vie (ACV) du lien usage des sols – changement climatique : revue critique des méthodologies existantes, Projet SOCLE, soil organic carbon changes in LCA, which evaluations to improve environmental assessments? ADEME - Agence de l'Environnement et de la Maîtrise de l'Energie.
- Benoist, A., Cornillier, C., 2016. Towards a consensual method to assess climate change impacts from bio-based systems, in: SETAC Europe Annual Meeting: Environmental Contaminants from Land to Sea: Continuities and Interface in Environmental Toxicology and Chemistry. Nantes : SETAC Europe, 2 p. SETAC Europe Annual Meeting: Environmental Contaminants from Land to Sea: Continuit.
- Besnard, A., Ferchaud, F., Levrault, F., Nguyen, E., Marsac, S., Savouré, M., 1, 2014. Le Lignoguide: Une aide aux choix des cultures biomasse. *Innov. Agron.* 34, 35–50.
- Beuch, S., Boelcke, B., Belau, L., 2000. Effect of the organic residues of *Miscanthus x giganteus* on the soil organic matter level of arable soils. *J. Agron. Crop Sci.* 184, 111–119. <https://doi.org/10.1046/j.1439-037X.2000.00367.x>
- Bockstaller, C., Girardin, P., 2010. Mode de calcul des indicateurs agri-environnementaux de la methode Indigo®, UMR INPL(ENSAIA)-INRA Agronomie et Environnement. Nancy-Colmar BP. France.
- Bolinder, M.A., Janzen, H.H., Gregorich, E.G., Angers, D.A., VandenBygaart, A.J., 2007. An approach for estimating net primary productivity and annual carbon inputs to soil for common agricultural crops in Canada. *Agric. Ecosyst. Environ.* 118, 29–42. <https://doi.org/10.1016/j.agee.2006.05.013>
- Bolinder, M.A., Vandenbygaart, A.J., Gregorich, E.G., Angers, D.A., Janzen, H.H., 2006. Modelling soil organic carbon stock change for estimating whole-farm greenhouse gas emissions. *Can. J. Soil Sci.* 86, 419–429. <https://doi.org/10.4141/S05-102>
- Bos, U., Horn, R., Beck, T., Lindner, J.P., Fischer, M., 2016. LANCA ® Characterization Factors for Life Cycle Impact Assessment. Version 2.0. Fraunhofer Institute for Building Physics. Fraunhofer Verlag. Stuttgart. Germany.
- Bouthier, A., Duparque, A., Mary, B., Sagot, S., Trochard, R., Levert, M., Houot, S., Damay, N., Denoroy, P., Dinh, J.-L., Blin, B., Ganteil, F., 2014. Adaptation et mise en œuvre du modèle de calcul de bilan humique à long terme AMG dans une large gamme de systèmes de grandes cultures et de polyculture-élevage. *Innov. Agron.* 34, 125–139.
- Brandão, M., Lefebvre, A., Kirschbaum, M.U.F., Weidema, B.P., Cowie, A.L., Jørgensen, S.V., Hauschild, M.Z., Pennington, D.W., Chomkamsri, K., 2013. Key issues and options in accounting for carbon sequestration and temporary storage in life cycle assessment and carbon footprinting. *Int. J. Life Cycle Assess.* 18, 230–240. <https://doi.org/10.1007/s11367-012-0451-6>
- Brandão, M., Milà i Canals, L., 2013. Global characterisation factors to assess land use impacts on biotic production. *Int. J. Life Cycle Assess.* 18, 1243–1252. <https://doi.org/10.1007/s11367-012-0381-3>
- Brandão, M., Milà i Canals, L., Clift, R., 2011. Soil organic carbon changes in the cultivation of energy crops: Implications for GHG balances and soil quality for use in LCA. *Biomass and Bioenergy* 35, 2323–2336. <https://doi.org/10.1016/j.biombioe.2009.10.019>
- Brilli, L., Bechini, L., Bindi, M., Carozzi, M., Cavalli, D., Conant, R., Dorich, C.D., Doro, L., Ehrhardt, F., Farina, R., Ferrise, R., Fitton, N., Francaviglia, R., Grace, P., Iocola, I., Klumpp, K., Léonard, J., Martin, R., Massad, R.S., Recous, S., Seddaiu, G., Sharp, J., Smith, P., Smith, W.N., Soussana, J.F., Bellocchi,

- G., 2017. Review and analysis of strengths and weaknesses of agro-ecosystem models for simulating C and N fluxes. *Sci. Total Environ.* 598, 445–470. <https://doi.org/10.1016/j.scitotenv.2017.03.208>
- BSI, 2011. PAS 2050:2011 - Specification for the assessment of the life cycle greenhouse gas emissions of goods and services, BSI 2011. London: The British Standards Institution. <https://doi.org/978 0 580 71382 8>
- Caldeira-Pires, A., Benoist, A., Luz, S.M. da, Silverio, V.C., Silveira, C.M., Machado, F.S., 2018. Implications of removing straw from soil for bioenergy: An LCA of ethanol production using total sugarcane biomass. *J. Clean. Prod.* 181, 249–259. <https://doi.org/10.1016/j.jclepro.2018.01.119>
- Campbell, E.E., Paustian, K., 2015. Current developments in soil organic matter modeling and the expansion of model applications: A review. *Environ. Res. Lett.* 10. <https://doi.org/10.1088/1748-9326/10/12/123004>
- Campell, E., Paustian, K., 2015. Current developments in soil organic matter modeling and the expansion of model applications. *Environ. Res. Lett.* 10, 123004. <https://doi.org/10.1088/1748-9326/10/12/123004>
- Carvalho, J.L., Hudiburg, T.W., Franco, H.C., DeLucia, E.H., 2017. Contribution of above- and belowground bioenergy crop residues to soil carbon. *GCB Bioenergy* 9, 1333–1343. <https://doi.org/10.1111/gcbb.12411>
- Cattelan, A.J., Dall’Agnol, A., 2018. The rapid soybean growth in Brazil. *Oilseeds fats Crop. Lipids* 25, D102. <https://doi.org/10.1051/ocl/2017058>
- CGIAR, 2018. 4 pour 1000: preserving soils for carbon capture and food security [WWW Document]. *Res. Progr. Water, L. Ecosyst.* URL <https://wle.cgiar.org/4-pour-1000-preserving-soils-carbon-capture-and-food-security> (accessed 2.1.18).
- Ci, E., Al-kaisi, M.M., Wang, L., Ding, C., Xie, D., 2015. Soil Organic Carbon Mineralization as Affected by Cyclical Temperature Fluctuations in a Karst Region of Southwestern China. *Pedosphere* 25, 512–523. [https://doi.org/10.1016/S1002-0160\(15\)30032-1](https://doi.org/10.1016/S1002-0160(15)30032-1)
- Clivot, H., Mouny, J.-C., Duparque, A., Dinh, J.-L., Denoroy, P., Houot, S., Vertès, F., Trochard, R., Bouthier, A., Sagot, S., Mary, B., 2019. Modeling soil organic carbon evolution in long-term arable experiments with AMG model. *Environ. Model. Softw.* 118, 99–113. <https://doi.org/10.1016/j.envsoft.2019.04.004>
- Coleman, K., Jenkinson, D.S., 2014. RothC - A model for the turnover of carbon in soil. Model description and users guide (updated June 2014), Rothamsted Research. Rothamsted Research. Herts, UK.
- Delphin, J.E., 2000. Estimation of nitrogen mineralization in the field from an incubation test and from soil analysis. *Agronomie* 20, 349–361. <https://doi.org/10.1051/agro:2000132>
- Derrien, D., Dignac, M.-F., Basile-Doelsch, I., Barot, S., Cécillon, L., Chenu, C., Chevallier, T., Freschet, G.T., Garnier, P., Guenet, B., Hedde, M., Klumpp, K., Lashermes, G., Maron, P.-A., Nunan, N., Roumet, C., Barré, P., 2016. Stocker du C dans les sols : Quels mécanismes, quelles pratiques agricoles, quels indicateurs ?, in: *Étude et Gestion Des Sols*. pp. 193–224.
- Duparque, A., Dinh, J., Mary, B., Bouthier, A., Blin, B., Denoroy, P., Ganteil, F., Houot, S., Levert, M., Sagot, S., Trochard, R., Territoires, A.R., Brunehaut, C., 2013. AMG : a simple SOC balance model used in France for decision support, in: *SOMpatic* (November 20-22, 2013). Rauschholtzhausen. Germany.
- Dupuy, L., Gregory, P.J., Bengough, A.G., 2010. Root growth models: Towards a new generation of continuous approaches. *J. Exp. Bot.* 61, 2131–2143. <https://doi.org/10.1093/jxb/erp389>

- EC-JRC, 2010. Framework and Requirements for Life Cycle Impact Assessment Models and Indicators, International Reference Life Cycle Data System (ILCD) Handbook. European Commission - Joint Research Centre - Institute for Environment and Sustainability. <https://doi.org/10.2788/38719>
- EC, 2018a. EU Climate Action: Climate strategies & targets [WWW Document]. Eur. Comm. Platf. URL https://ec.europa.eu/clima/policies/strategies_en (accessed 2.7.18).
- EC, 2018b. Product Environmental Footprint Category Rules Guidance v6.3, PEF CR Guidance document, - Guidance for the development of Product Environmental Footprint Category Rules (PEFCRs), version 6.3. Ispra: JRC-Joint Research Centre, Italy.
- Edwards, R., Lariv', J.-F., Richeard, D., Weinhof, W., 2014. Well-to-Tank Report" Version 4.a: JEC Well-To-Wheels Analysis of Future Automotive Fuels and Powertrains in the European Context, Report EUR 26237 EN. Ispra: JRC-Joint Research Centre. <https://doi.org/10.2790/95629>
- EUROSTAT, 2019. Climate change - driving forces [WWW Document]. URL [https://ec.europa.eu/eurostat/statistics-explained/index.php?title=File:Greenhouse_gas_emissions_by_IPCC_source_sector,_EU28,_change_from_1990_to_2016_\(million_tonnes_of_CO2_equivalent_and_%25_change\).png](https://ec.europa.eu/eurostat/statistics-explained/index.php?title=File:Greenhouse_gas_emissions_by_IPCC_source_sector,_EU28,_change_from_1990_to_2016_(million_tonnes_of_CO2_equivalent_and_%25_change).png) (accessed 3.1.19).
- FAO, 2018. Measuring and modelling soil carbon stocks and stock changes in livestock production systems: Guidelines for assessment (Draft for public review), FAO publications. Livestock Environmental Assessment and Performance (LEAP) Partnership. Rome, Italy.
- FAO, 2017. Soil Organic Carbon: the hidden potential. Rome: Food and Agriculture Organization of the United Nations.
- FAO, 2004. Fertilizer Use by Crop in Brazil Land and Plant Nutrition Management Service Land and Water Development Division. FAO- Food and Agriculture Organisation of the United Nations. Rome.
- Frank, S., Schmid, E., Havlík, P., Schneider, U.A., Böttcher, H., Balkovič, J., Obersteiner, M., 2015. The dynamic soil organic carbon mitigation potential of European cropland. *Glob. Environ. Chang.* 35, 269–278. <https://doi.org/10.1016/j.gloenvcha.2015.08.004>
- Frisque, M., 2007. Gestion des matières organiques dans les sols cultivés en Région wallonne : avantages agronomiques, avantages environnementaux et séquestration du carbone Directeurs. Université Libre de Bruxelles IGEAT Institut de Gestion de l'Environnement et d'Aménagement du Territoire.
- Gobin, A., Campling, L., Janssen, N., Desmet, H., Delden, V., Hurkens, J., Lavelle, P., Berman, S., 2011. Soil organic matter management across the EU – best practices, constraints and trade-offs, Final Report for the European Commission's DG Environment. Technical Report - 2011 - 051. <https://doi.org/10.2779/17252>
- Goglio, P., Grant, B.B., Smith, W.N., Desjardins, R.L., Worth, D.E., Zentner, R., Malhi, S.S., 2014. Impact of management strategies on the global warming potential at the cropping system level. *Sci. Total Environ.* 490, 921–933. <https://doi.org/10.1016/j.scitotenv.2014.05.070>
- Goglio, P., Smith, W.N., Grant, B.B., Desjardins, R.L., Gao, X., Hanis, K., Tenuta, M., Campbell, C.A., McConkey, B.G., Nemecek, T., Burgess, P.J., Williams, A.G., 2018. A comparison of methods to quantify greenhouse gas emissions of cropping systems in LCA. *J. Clean. Prod.* 172, 4010–4017. <https://doi.org/10.1016/j.jclepro.2017.03.133>

Chapter 5: Agriculture: Soil organic carbon modelling

- Goglio, P., Smith, W.N., Grant, B.B., Desjardins, R.L., McConkey, B.G., Campbell, C.A., Nemecek, T., 2015. Accounting for soil carbon changes in agricultural life cycle assessment (LCA): A review. *J. Clean. Prod.* 104, 23–39. <https://doi.org/10.1016/j.jclepro.2015.05.040>
- Grogan P., Matthews, R., 2002. A modelling analysis of the potential for soil carbon sequestration under short rotation coppice willow bioenergy plantations. *Soil Use Manag.* 18, 175–183. <https://doi.org/10.1079/SUM2002119>
- Guest, G., Cherubini, F., Strømman, A.H., 2013. The role of forest residues in the accounting for the global warming potential of bioenergy. *GCB Bioenergy* 5. <https://doi.org/10.1111/gcbb.12014>
- Gueudet, A., 2012. Action CASDAR « ACV et fertilisation » Fiches sur les modèles d'émission. ACTA, ARVALIS, IRSTEA.
- Han, X., Gao, G., Chang, R., Li, Z., Ma, Y., Wang, S., Wang, C., Lü, Y., Fu, B., 2018. Changes in soil organic and inorganic carbon stocks in deep profiles following cropland abandonment along a precipitation gradient across the Loess Plateau of China. *Agric. Ecosyst. Environ.* 258, 1–13. <https://doi.org/10.1016/j.agee.2018.02.006>
- Harvey, M., Pilgrim, S., 2011. The new competition for land: Food, energy, and climate change. *Food Policy* 36, S40–S51. <https://doi.org/10.1016/j.foodpol.2010.11.009>
- Henin, S., Dupuis, M., 1945. Essai de bilan de la matière organique du sol. *Ann. Agron.* 1, 19–29.
- Horn, R., Maier, S., 2018. LANCA®- Characterization Factors for Life Cycle Impact Assessment, Version 2.5. [WWW Document]. Fraunhofer Inst. URL <http://publica.fraunhofer.de/documents/N-379310.html> (accessed 7.31.19).
- INRA, 2019. Stocker du carbone dans les sols français : quel potentiel au regard de l'objectif 4 pour 1000 et à quel cout ? Réalisée pour l'ADEME et le Ministère de l'Agriculture et de l'Alimentation. Paris.
- IPCC, 2006. 2006 IPCC Guidelines for National Greenhouse Gas Inventories. The Intergovernmental Panel on Climate Change (IPCC).
- Irizar, A.B., Delaye, L.A.M., Andriulo, A.E., 2015. Projection of Soil Organic Carbon Reserves in the Argentine Rolling Pampa Under Different Agronomic Scenarios. Relationship of these Reserves with Some Soil Properties. *Open Agric. J.* 9, 30–41. <https://doi.org/10.2174/1874331501509010030>
- Joly, D., Brossard, T., Cardot, H., Cavailhes, J., Hilal, M., Wavresky, P., 2010. Les types de climats en France, une construction spatiale - Types of climates on continental France, a spatial construction. *Cybergéo Eur. J. Geogr.* 1–23. <https://doi.org/10.4000/cybergeo.23155>
- Koellner, T., Baan, L., Beck, T., Brandão, M., Civit, B., Margni, M., Canals, L.M., Saad, R., Souza, D.M., Müller-Wenk, R., 2013. UNEP-SETAC guideline on global land use impact assessment on biodiversity and ecosystem services in LCA. *Int. J. Life Cycle Assess.* 18, 1188–1202. <https://doi.org/10.1007/s11367-013-0579-z>
- Kwiatkowska-Malina, J., 2018. Qualitative and quantitative soil organic matter estimation for sustainable soil management. *J. Soils Sediments* 18, 2801–2812. <https://doi.org/10.1007/s11368-017-1891-1>
- Le Villio, M., Arrouays, D., Deslais, W., Daroussin, J., Le Bissonnais, Y., Clergeot, D., 2001. Estimation des quantités de matière organique exogène nécessaires pour restaurer et entretenir les sols limoneux français à un niveau organique donné. *Etude Gest. des Sols* 8, 47–64.

- Lehmann, J., Kleber, M., 2015. The contentious nature of soil organic matter. *Nature* 1–9. <https://doi.org/10.1038/nature16069>
- Lemus, R., Lal, R., 2005. Bioenergy crops and carbon sequestration. *CRC. Crit. Rev. Plant Sci.* 24, 1–21. <https://doi.org/10.1080/07352680590910393>
- Levasseur, A., Cavalett, O., Fuglestvedt, J.S., Gasser, T., Johansson, D.J.A., Jørgensen, S. V., Rauegi, M., Reisinger, A., Schivley, G., Strømman, A., Tanaka, K., Cherubini, F., 2016. Enhancing life cycle impact assessment from climate science: Review of recent findings and recommendations for application to LCA. *Ecol. Indic.* 71, 163–174. <https://doi.org/10.1016/j.ecolind.2016.06.049>
- Levasseur, A., Lesage, P., Margni, M., Deschênes, L., Samson, R., 2010. Considering time in LCA: Dynamic LCA and its application to global warming impact assessments. *Environ. Sci. Technol.* 44, 3169–3174. <https://doi.org/10.1021/es9030003>
- Liang, B.C., Campbell, C.A., McConkey, B.G., Padbury, G., Collas, P., 2005. An empirical model for-estimating carbon sequestration on the Canadian prairies. *Can. J. Soil Sci.* 85, 549–556. <https://doi.org/10.4141/S04-089>
- Lorne, D., Tchong-Ming, S., 2012. The French biofuels mandates under cost uncertainty – an assessment based on robust optimization. *Les Cah. l'économie* 33.
- Loulou, R., Lehtilä, A., Kanudia, A., Remme, U., Goldstein, G., 2016. Documentation for the TIMES Model PART II: Reference Manual, Energy Technology Systems Analysis Programme. ETSAP-Energy Technology Systems Analysis Programme.
- Ma, S., He, F., Tian, D., Zou, D., Yan, Z., Yang, Y., Zhou, T., Huang, K., Shen, H., Fang, J., 2018. Variations and determinants of carbon content in plants: A global synthesis. *Biogeosciences* 15, 693–702. <https://doi.org/10.5194/bg-15-693-2018>
- Mi, J., Liu, W., Yang, W., Yan, J., Li, J., Sang, T., 2014. Carbon sequestration by *Miscanthus* energy crops plantations in a broad range semi-arid marginal land in China. *Sci. Total Environ.* 496, 373–380. <https://doi.org/10.1016/j.scitotenv.2014.07.047>
- Milà i Canals, L., Bauer, C., Depestele, J., Dubreuil, A., Knuchel, R.F., 2007a. Key Elements in a Framework for Land Use Impact Assessment Within LCA. *Int. J. Life Cycle Assess.* 12, 5–15. <https://doi.org/10.1065/lca2006.05.250>
- Milà i Canals, L., Romanyà, J., Cowell, S.J., 2007b. Method for assessing impacts on life support functions (LSF) related to the use of “fertile land” in Life Cycle Assessment (LCA). *J. Clean. Prod.* 15, 1426–1440. <https://doi.org/10.1016/j.jclepro.2006.05.005>
- Minasny, B., Malone, B.P., McBratney, A.B., Angers, D.A., Arrouays, D., Chambers, A., Chaplot, V., Chen, Z.-S., Cheng, K., Das, B.S., Field, D.J., Gimona, A., Hedley, C.B., Hong, S.Y., Mandal, B., Marchant, B.P., Martin, M., McConkey, B.G., Mulder, V.L., O'Rourke, S., Richer-de-Forges, A.C., Odeh, I., Padarian, J., Paustian, K., Pan, G., Poggio, L., Savin, I., Stolbovoy, V., Stockmann, U., Sulaeman, Y., Tsui, C.-C., Vågen, T.-G., van Wesemael, B., Winowiecki, L., 2017. Soil carbon 4 per mille. *Geoderma* 292, 59–86. <https://doi.org/10.1016/j.geoderma.2017.01.002>
- Moreno, R., Studdert, G.A., G, M.M., I, I.A., 2016. Soil organic carbon changes simulated with the AMG model in a high-organic-matter Mollisol. *Spanish J. Soil Sci.* 6, 212–229. <https://doi.org/10.3232/SJSS.2016.V6.N3.04>

- MTES, 2018. Loi de transition énergétique pour la croissance verte [WWW Document]. Ministère la Transit. écologique solidaire. URL <https://www.ecologique-solidaire.gouv.fr/loi-transition-energetique-croissance-verte> (accessed 1.29.18).
- Müller-Wenk R, Brandão M (2010) Climatic impact of land use in LCA — carbon transfers between vegetation / soil and air. *Int J Life Cycle Assess* 15:172–182. doi: 10.1007/s11367-009-0144-y
- Myhre, G., Shindell, D., Bréon, F.-M., Collins, W., Fuglestedt, J., Huang, J., Koch, D., Lamarque, J.-F., Lee, D., Mendoza, B., Nakajima, T., Robock, A., Stephens, G., Takemura, T., Zhang, H., 2013. Chapter 8 Anthropogenic and Natural Radiative Forcing, in: Stocker, T.F., D. Qin, G.-K. Plattner, M. Tignor, S.K. Allen, J. Boschung, A. Nauels, Y. Xia, V.B. and P.M.M. (eds.). (Ed.), In: *Climate Change 2013: The Physical Science Basis. Contribution of Working Group I to the Fifth Assessment Report of the Intergovernmental Panel on Climate Change* [Stocker, T.F., D. Qin, G.-K. Plattner, M. Tignor, S.K. Allen, J. Boschung, A. Nauels, Y. Cambridge University Press, Cambridge, United Kingdom and New York, pp. 659–740. <https://doi.org/10.1017/CBO9781107415324.018>
- Nagy, R.C., Porder, S., Brando, P., Davidson, E.A., Figueira, A.M. e. S., Neill, C., Riskin, S., Trumbore, S., 2018. Soil Carbon Dynamics in Soybean Cropland and Forests in Mato Grosso, Brazil. *J. Geophys. Res. Biogeosciences* 123, 18–31. <https://doi.org/10.1002/2017JG004269>
- Nemecek, T., Dubois, D., Huguenin-Elie, O., Gaillard, G., 2011. Life cycle assessment of Swiss farming systems: I. Integrated and organic farming. *Agric. Syst.* 104, 217–232. <https://doi.org/10.1016/j.agry.2010.10.002>
- Nemecek, T., Kagi, T., 2007. Life Cycle Inventories of Agricultural Production Systems Data v2.0 (2007),ecoinvent report No. 15. Swiss Center For Life Cycle Inventories.
- Nicolardot, B., Recous, S., Mary, B., 2001. Simulation of C and N mineralisation during crop residue decomposition: A simple dynamic model based on the C : N ratio of the residues 83–103. <https://doi.org/10.1023/A:1004813801728>
- Oberholzer, H.-R., Knuchel, R.F., Weisskopf, P., Gaillard, G., 2012. A novel method for soil quality in life cycle assessment using several soil indicators. <https://doi.org/10.1007/s13593-011-0072-7>
- Oberholzer, H.-R., Weisskopf, P., Gaillard, G., Weiss, F., Freiermuth Knuchel, R., 2006. Methode zur Beurteilung der Wirkungen landwirtschaftlicher Bewirtschaftung auf die Bodenqualität in Ökobilanzen.
- Petersen, B.M., 2003. C-TOOL version 1.1. A tool for simulation of soil carbon turnover. Description and users guide. Danish Institute of Agricultural Sciences.
- Petersen, B.M., Knudsen, M.T., Hermansen, J.E., Halberg, N., 2013. An approach to include soil carbon changes in life cycle assessments. *J. Clean. Prod.* 52, 217–224. <https://doi.org/10.1016/j.jclepro.2013.03.007>
- PHYLLIS 2 database, 2019. Phyllis2: Database for biomass and waste [WWW Document]. ECN.TNO. URL <https://phyllis.nl/> (accessed 2.20.19).
- Rehbein, K., Sandhage-hofmann, A., Amelung, W., 2015. Soil carbon accrual in particle-size fractions under *Miscanthus x. giganteus* cultivation. *Biomass and Bioenergy* 78, 80–91. <https://doi.org/10.1016/j.biombioe.2015.04.006>
- Richter, G.M., Agostini, F., Barker, A., Costomiris, D., Qi, A., 2016. Assessing on-farm productivity of *Miscanthus* crops by combining soil mapping, yield modelling and remote sensing. *Biomass and Bioenergy* 85, 252–261. <https://doi.org/10.1016/j.biombioe.2015.12.024>

- Saffih-Hdadi, K., Mary, B., 2008. Modeling consequences of straw residues export on soil organic carbon. *Soil Biol. Biochem.* 40, 594–607. <https://doi.org/10.1016/j.soilbio.2007.08.022>
- Sala S., Benini L., V., C., B., V.L., V., D.L., R., P., 2019. Suggestions for the update of the Environmental Footprint Life Cycle Impact Assessment: Impacts due to resource use, water use, land use, and particulate matter. EUR 28636 EN, Publications Office of the European Union, Luxembourg., <https://doi.org/10.2760/78072>
- Schmidinger, K., Stehfest, E., 2012. Including CO₂ implications of land occupation in LCAs — method and example for livestock products. *Int. J. Life Cycle Assess.* 17, 962–972. <https://doi.org/10.1007/s11367-012-0434-7>
- SDES, 2019. Chiffres clés du climat – France, Europe et Monde. Le service de la donnée et des études statistiques (SDES)- Ministère de la Transition Ecologique et Solidaire (MTES), Paris, France.
- Shibu, M.E., Leffelaar, P.A., Van Keulen, H., Aggarwal, P.K., 2006. Quantitative description of soil organic matter dynamics-A review of approaches with reference to rice-based cropping systems. *Geoderma* 137, 1–18. <https://doi.org/10.1016/j.geoderma.2006.08.008>
- Smith, W.N., Grant, B.B., Campbell, C.A., McConkey, B.G., Desjardins, R.L., Kröbel, R., Malhi, S.S., 2012. Crop residue removal effects on soil carbon: Measured and inter-model comparisons. *Agric. Ecosyst. Environ.* 161, 27–38. <https://doi.org/10.1016/j.agee.2012.07.024>
- Sommer, R., Bossio, D., 2014. Dynamics and climate change mitigation potential of soil organic carbon sequestration. *J. Environ. Manage.* 144, 83–87. <https://doi.org/10.1016/j.jenvman.2014.05.017>
- Strullu, L., Beaudoin, N., de Cortázar Azaola, I.G., Mary, B., 2014. Simulation of Biomass and Nitrogen Dynamics in Perennial Organs and Shoots of *Miscanthus × Giganteus* Using the STICS Model. *Bioenergy Res.* 7, 1253–1269. <https://doi.org/10.1007/s12155-014-9462-4>
- UNFCCC, 2018. Climate Get the Big Picture - A guide to the UNFCCC and its processes [WWW Document]. United Nations Conv. Clim. Chang. URL <https://bigpicture.unfccc.int/> (accessed 1.1.18).
- UNIFA, 1998. Chapter 1: Le Sol, in: *La Fertilisation*. UNIFA - Union des Industries de la Fertilisation (UNIFA), Union des Industries de la Fertilisation., pp. 1–78.
- White, R.E., Davidson, B., Lam, S.K., Chen, D., 2018. A critique of the paper ‘Soil carbon 4 per mille’ by Minasny et al. (2017).’ *Geoderma* 309, 115–117. <https://doi.org/10.1016/j.geoderma.2017.05.025>
- Wiesmeier, M., Hübner, R., Dechow, R., Maier, H., Spörlein, P., Geuß, U., Hangen, E., Reischl, A., Schilling, B., Lützw, M. Von, Kögel-knabner, I., 2014. Estimation of past and recent carbon input by crops into agricultural soils of southeast Germany. *Eur. J. Agron.* 61, 10–23. <https://doi.org/10.1016/j.eja.2014.08.001>
- Wiesmeier, M., Urbanski, L., Hobbey, E., Lang, B., Lützw, M. von, Marin-Spiotta, E., Wesemael, B. van, Rabot, E., Ließ, M., Garcia-Franco, N., Wollschläger, U., Vogel, H.-J., Kögel-Knabner, I., 2019. Soil organic carbon storage as a key function of soils - A review of drivers and indicators at various scales. *Geoderma* 333, 149–162. <https://doi.org/10.1016/j.geoderma.2018.07.026>
- Zanella, A., Bolzonella, C., Lowenfels, J., Ponge, J.F., Bouché, M., Saha, D., Kukal, S.S., Fritz, I., Savory, A., Blouin, M., Sartori, L., Tatti, D., Kellermann, L.A., Trachsel, P., Burgos, S., Minasny, B., Fukuoka, M., 2018. Humusica 2, article 19: Techno humus systems and global change–conservation agriculture and 4/1000 proposal. *Appl. Soil Ecol.* 122, 271–296. <https://doi.org/10.1016/j.apsoil.2017.10.036>

Chapter 5: Agriculture: Soil organic carbon modelling

- Zang, H., Blagodatskaya, E., Wen, Y., Xu, X., Dyckmans, J., Kuzyakov, Y., 2018. Carbon sequestration and turnover in soil under the energy crop *Miscanthus*: repeated¹³C natural abundance approach and literature synthesis. *GCB Bioenergy* 10, 262–271. <https://doi.org/10.1111/gcbb.12485>
- Zhong, Z., Chen, Z., Xu, Y., Ren, C., Yang, G., Han, X., Ren, G., Feng, Y., 2018. Relationship between Soil Organic Carbon Stocks and Clay Content under Different Climatic Conditions in Central China. *Forests* 9, 598. <https://doi.org/10.3390/f9100598>
- Zomer, R.J., Bossio, D.A., Sommer, R., Verchot, L. V., 2017. Global Sequestration Potential of Increased Organic Carbon in Cropland Soils. *Sci. Rep.* 7, 1–8. <https://doi.org/10.1038/s41598-017-15794-8>
- L., Beaudoin, N., de Cortázar Atauri, I.G., Mary, B., 2014. Simulation of Biomass and Nitrogen Dynamics in Perennial Organs and Shoots of *Miscanthus* × *Giganteus* Using the STICS Model. *Bioenergy Res.* 7, 1253–1269. <https://doi.org/10.1007/s12155-014-9462-4>
- UNFCCC, 2018. Climate Get the Big Picture - A guide to the UNFCCC and its processes [WWW Document]. United Nations Conv. Clim. Chang. URL <https://bigpicture.unfccc.int/> (accessed 1.1.18).
- UNIFA, 1998. Chapter 1: Le Sol, in: *La Fertilisation*. UNIFA - Union des Industries de la Fertilisation (UNIFA), Union des Industries de la Fertilisation., pp. 1–78.
- White, R.E., Davidson, B., Lam, S.K., Chen, D., 2018. A critique of the paper ‘Soil carbon 4 per mille’ by Minasny et al. (2017).’ *Geoderma* 309, 115–117. <https://doi.org/10.1016/j.geoderma.2017.05.025>
- Wiesmeier, M., Hübner, R., Dechow, R., Maier, H., Spörlein, P., Geuß, U., Hangen, E., Reischl, A., Schilling, B., Lützw, M. Von, Kögel-knabner, I., 2014. Estimation of past and recent carbon input by crops into agricultural soils of southeast Germany. *Eur. J. Agron.* 61, 10–23. <https://doi.org/10.1016/j.eja.2014.08.001>
- Zanella, A., Bolzonella, C., Lowenfels, J., Ponge, J.F., Bouché, M., Saha, D., Kukal, S.S., Fritz, I., Savory, A., Blouin, M., Sartori, L., Tatti, D., Kellermann, L.A., Trachsel, P., Burgos, S., Minasny, B., Fukuoka, M., 2018. Humusica 2, article 19: Techno humus systems and global change–conservation agriculture and 4/1000 proposal. *Appl. Soil Ecol.* 122, 271–296. <https://doi.org/10.1016/j.apsoil.2017.10.036>
- Zang, H., Blagodatskaya, E., Wen, Y., Xu, X., Dyckmans, J., Kuzyakov, Y., 2018. Carbon sequestration and turnover in soil under the energy crop *Miscanthus*: repeated¹³C natural abundance approach and literature synthesis. *GCB Bioenergy* 10, 262–271. <https://doi.org/10.1111/gcbb.12485>
- Zhong, Z., Chen, Z., Xu, Y., Ren, C., Yang, G., Han, X., Ren, G., Feng, Y., 2018. Relationship between Soil Organic Carbon Stocks and Clay Content under Different Climatic Conditions in Central China. *Forests* 9, 598. <https://doi.org/10.3390/f9100598>
- Zomer, R.J., Bossio, D.A., Sommer, R., Verchot, L. V., 2017. Global Sequestration Potential of Increased Organic Carbon in Cropland Soils. *Sci. Rep.* 7, 1–8. <https://doi.org/10.1038/s41598-017-15794-8>

5.3 Manuscript 5: Model integration in the context of oil palm-based surfactants

This manuscript (not submitted to any Journal) represents a model integration applied to a partially oil palm- and petroleum-sourced surfactant used in personal care products. The case study couples static LCA results with dynamic C_{bio} impacts. Therefore, a full lifetime dynamic C_{bio} accounting approach of all oil palm crop fractions is developed, involving SOC. The purpose is to identify whether dynamic modelling significantly influences the final results and whether mitigation potentials are accountable for biochemical products.

Objective	Perform a model integration, by considering modelling approaches developed in previous case studies to assess dynamic carbon footprint of biochemical surfactants linked with palm kernel oil consumption, by: <ul style="list-style-type: none"> Accounting for all biogenic elementary flows from the upstream to the downstream Computing C_{bio} factors applicable to any technical flow or mass flow Comparing with static GWP results
Approach	Develop a C_{bio} balance by means of a full lifetime accounting approach, involving C_{bio} sequestration, SOC dynamic and remaining C_{bio} releases from mill and end-of-life processes by means of non-destructive methods of previous mi
Sector (product)	Oleochemical derivatives
Biomass	Oil palm
Supporting data	Dynamic C_{bio} flows and biogenic factors provided in the Supplementary Material Appendix G: SM of Manuscript

Dynamic full lifetime biogenic carbon modelling of oil palm: A simplified case study applied to a derived biochemical surfactant

Ariane Albers^{a, b, c, *}, **Cécile Bessou**^{d, f}, **Anthony Benoist**^{c, e, f}, **Pierre Collet**^a, **Arnaud Hélias**^{b, c, g}

^a IFP Energies Nouvelles, 1 et 4 Avenue de Bois-Préau, 92852 Rueil-Malmaison, France

^b LBE, Montpellier SupAgro, INRA, UNIV Montpellier, Narbonne, France

^c Elsa, Research Group for Environmental Lifecycle and Sustainability Assessment, Montpellier, France

^d CIRAD, UPR Systeme de Pérennes, Montpellier, France

^e CIRAD, UPR BioWooEB, F-34398 Montpellier, France

^f Univ Montpellier, CIRAD, Montpellier, France

^g ITAP, Irstea, Montpellier SupAgro, Univ Montpellier, ELSA Research Group, Montpellier, France

Abstract

Oil palm accounts for 34% of the total global production of vegetable oils. Certification schemes for sustainable oil palm production take into account dynamic biogenic carbon (C_{bio}) sequestration from biomass growth. However, soil organic carbon (SOC) dynamics and C_{bio} releases are not accounted for, thus excluding end-of-life emissions to the atmosphere. In the context of dynamic life cycle assessment (LCA), this study aims at developing a full lifetime accounting approach, including upstream and downstream processes, based on a simplified case study of an oleochemical derivative from palm kernel oil, namely Sodium Lauryl Ether Sulphate (SLES). Dynamic C_{bio} flows are coupled with technical flows from a previous conventional LCA study of SLES, to generate a complete time depended carbon balance (fossil + biogenic). The dynamic biogenic impacts resulted in $-0.06 \text{ kg CO}_2\text{-eq}\cdot\text{kg}^{-1}$ SLES over a fixed time horizon of 100 years, reducing the conventional carbon neutral impacts by 3%. A sensitivity analysis on the model parameters, based on variations between minimum and maximum values for fresh fruit bunch yield (8 to $40 \text{ t}\cdot\text{ha}^{-1}$), rotation length (20 to 30 years), palm tree density (100 and $200 \text{ trees}\cdot\text{ha}^{-1}$), and k decomposition (mineralisation) coefficient (multiplied by a factor of 0.5 and 2). It was demonstrated that C-complete (fossil + biogenic) accounting estimates higher climate mitigation effects with increasing yield, rotation length and number of trees, due to higher C_{bio} values embedded in the biomass over a longer period of time. Moreover, a scenario comparison of other C_{bio} release pathways showed the variability of the results in the short-term. The model estimations can be further refined to site-specific parameters and oil palm-derived products.

Keywords: biogenic carbon; dynamic modelling; dynamic LCA; surfactant; oil palm; SOC

Acronyms

C_{bio}	Biogenic Carbon	MIPB	Male Inflorescence Plant Biomass
CPO	Crude Palm Oil	PKO	Palm Kernel Oil
DBH	Diameter-Breast-Height	PKS	Palm Kernel Shell
EFB/FFB	Empty/Fresh Fruit Bunches	POME	Palm Oil Mill Effluent
FBB	Fronds Base Biomass	RF	Radiative Forcing
GHG	Greenhouse Gas Emissions	SLES	Sodium Lauryl Ether Sulphate
H	Height	SOC	Soil Organic Carbon
MFF	Mesocarb Fruit Fibres	SOM	Soil Organic Matter

1 Introduction

Oil Palm (*Elaeis guineensis*), a perennial crop producing edible vegetable oil, was discovered in the 13th century in West Africa (Corley and Tinker, 2003). The main producing countries are Indonesia and Malaysia, representing 90% of total global production with volumes up to 43 and 21 million tonnes, respectively, in 2018 (IndexMundi, 2019). Mean crude palm oil (CPO) yields range between 2 and $10 \text{ t}\cdot\text{ha}^{-1}\cdot\text{yr}^{-1}$, depending on the region, eventually attaining peak values of $12 \text{ t}\cdot\text{ha}^{-1}\cdot\text{yr}^{-1}$, whereof the global mean yield is $3 \text{ t}\cdot\text{ha}^{-1}\cdot\text{yr}^{-1}$ (Woittiez et al., 2017). Today, palm oil is one of the most

produced vegetable oils in the world, with a total share of the global production of about 34% (OECD-FAO, 2013).

Oil palm feedstock has increasingly gained importance in non-food related industries, as a substrate for chemicals (cosmetics, detergents) and biofuels. A large number of oil palm related life cycle assessments (LCA) and carbon footprint studies have been performed, including studies of mill production systems (Stichnothe and Schuchardt, 2011), comparative studies with other vegetable oils (Schmidt, 2015, 2010), palm kernel oil application in cosmetic creams (Martinez et al., 2017), crude palm oil refinement into biodiesel (Castanheira and Freire, 2017; Choo et al., 2011; Hansen et al., 2012; Rivera-Méndez et al., 2017), methodological LCI and parameter choices (Archer et al., 2018), carbon reduction potentials (Patthanaissaranukool et al., 2013), biogas production from palm oil mill effluents (Nasution et al., 2018), and combined LCA/techno-economic analysis of empty fruit bunches for bioenergy (Vaskan et al., 2018); among other subjects.

Expansion of oil palm plantations has driven to critical deforestation, associated with land use change and peat soil oxidation from peat swamp forests draining, further affecting biodiversity, carbon stock losses and emissions, water filtration and pest control (Koh et al., 2011). The consequences remain largely unquantified and concerns have been raised regarding peat lands considered as degraded or marginal lands disposable for agriculture (Koh et al., 2011).

Oil palm plantations on peat soils have continuously increased since the 80s (Henson, 2004). CO₂ emissions from peat oxidation have been estimated at about 37 t CO₂·ha⁻¹ (Schmidt, 2007). More recently a LCA study in Malaysia, where 13% of oil palm is planted on peat, estimated GHG emissions from land use change and peat soil ranging between 12.4 t CO₂-eq·ha⁻¹ (best case with low peat oxidation) to 76.6 t CO₂-eq·ha⁻¹ (worst case with highest peat oxidation). The large variations are attributed to previously carbon stocks, depth and time length of drainage, nitrogen emissions from mineral fertiliser and CH₄ capture and use at mill (Hashim et al., 2018).

International efforts have been conducted to support sustainable oil palm production. A voluntary certification scheme is handled by the Roundtable on Sustainable Palm Oil (RSPO), which has certified about 19% of the global oil palm production (<https://www.rspo.org/>). The RSPO certification applies a cradle-to-gate LCA approach (i.e. involving agriculture and mill life cycle phases) for the calculation of GHG emissions via the PalmGHG tool (Chase et al., 2012).

Pilot implementations have demonstrated mean GHG emissions of 1.67 t CO₂-eq·t⁻¹ from CPO production, with large variations ranging between -0.02 and 8.32 t CO₂-eq·t⁻¹ CPO (Bessou et al., 2014), whereas negative values represent a net GHG sink, as the avoided emissions from mill are higher than the emitted ones. Higher levels of GHG emissions have been attributed to land clearing, proportion of peat soil and no CH₄ capture and use. Plantations on mineral soils and mill facilities with

on-site energy from CH₄-capture can achieved net GHG emissions below 0.5 t CO₂-eq·t⁻¹ CPO (Chase et al., 2012).

Annual carbon sequestration models have been developed, such as the OPRODSIM and OPCABSIM models by Henson (2005, 2009), to estimate the biogenic carbon (C_{bio}) stocks in aboveground oil palm biomass. These modelling data is applicable in the RSPO PalmGHG calculator when site-specific measurements are not available (Chase et al., 2012). However, the modelling approach excludes belowground biomass (i.e. roots) (Henson, 2009) and the upstream soil organic carbon (SOC) dynamic from the dead/residual biomass added to the soil. Moreover, the scope of the study involves cultivation of oil palm and processes at the mill facility, excluding C_{bio} releases to the atmosphere at the end-of-life (EOL) phase of CPO derivatives. Thus, the GHG calculations do not represent the technical flows (i.e. mass flows) of CPO or palm kernel oil (PKO) -based end-products.

Given these shortcomings concerning C_{bio} modelling, this study aims at developing a dynamic full lifetime C_{bio} accounting approach, including upstream and downstream processes, to account for the biogenic-sourced emissions, involving C_{bio} sequestration and soil organic carbon (SOC) dynamics associated with the consumption of oil palm feedstock (crude palm or palm kernel oil) in an end-product, here applied to an oleochemical derivative (surfactant for personal care products).. The computation of the dynamic C_{bio} flows is constructed in a way that any technical flow (here amount of palm oil) can be assessed with the dynamic C_{bio} model to evaluate both static and dynamic carbon footprints. The case study is based on a simplified representation of the surfactant product, as the primary objective is to explore and development of dynamic C_{bio} inventories.

2 Material and methods

The purpose of this study is to develop a dynamic C_{bio} modelling approach of all life cycle phases of an oleochemical derivative, partially based on palm kernel oil (PKO) and petroleum feedstocks. The final product is Sodium Lauryl Ether Sulphate (SLES), used as surfactant in personal care products (e.g. shampoos and shower gels). Data from a previous conventional LCA study is used and further processed to generate a complete carbon balance (fossil + biogenic carbon emissions) associated to the SLES end-product pathway.

The LCA study involves a cradle-to-gate approach, using 1 kg SLES surfactant partially PKO-sourced as the functional unit. The ecoinvent v3 database was used for the inventory and the characterisation was based on the ReCiPe 2016 midpoint v1.03 (Huijbregts et al., 2016) method, using SimaPro. From the original LCA study we take into account the global warming potential (GWP) results estimated at 1.77 kg CO₂-eq·kg⁻¹ SLES, and exclude all other impact categories.

The calculated GHG emissions are based on the carbon neutral hypothesis. The results are therefore static, as the time-dependent C_{bio} and SOC flows are not inventoried. This study thus adds the missing

biogenic-sourced flows to the carbon neutral GHG inventories by applying a coupling approach earlier presented in Albers et al. (2019a). The coupling allows coupling C_{bio} models with the outputs of any demand model (in this case with the static inventories). A scenario comparison is further performed by modifying the C_{bio} modelling assumption and SLES pathways to test the sensitivity of the results.

2.1 Study scope of biogenic carbon modelling

The dynamic C_{bio} modelling approach covers all life cycle phases: from the crop cultivation and harvesting activities, through oil palm extraction and co-production at mill, with further refinements to produce fatty alcohols and SLES, to the EOL of SLES, as illustrated in Fig. 1.

The modelling approach considers the time-dependent C_{bio} flows by means of a full lifetime C_{bio} accounting from upstream to downstream, by involving:

- i) oil palm growth and C_{bio} sequestration over the entire rotation length of different plant organs (i.e. all crop fraction in the above- and belowground biomass compartments),
- ii) SOC dynamic representing the C_{bio} releases from dead biomass and organic fertilisers or soil amendments (milling organic co-products), and
- iii) EOL C_{bio} releases from the SLES at the wastewater treatment facility, because the surfactant is contained in self-care products such as shampoo or shower gels.

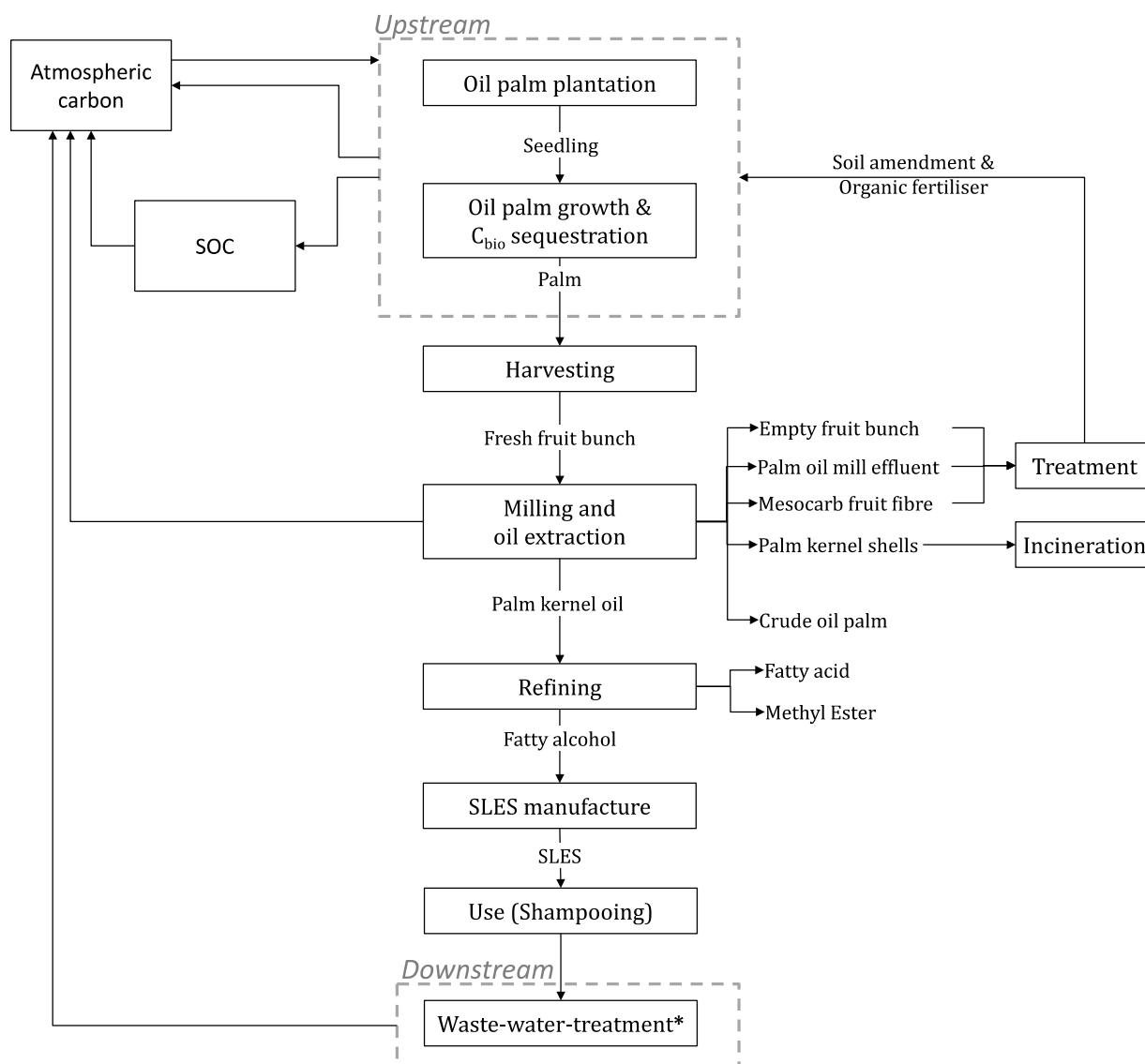

* assuming an instant C_{bio} release to the atmosphere

Fig. 1. Study scope of biogenic carbon and soil organic carbon (SOC) upstream to downstream dynamic modelling to assess the atmospheric carbon exchanges from life cycle of Sodium Lauryl Ether Sulphate (SLES) product pathway based on palm kernel oil. Source: adapted from Choo et al. (2011) and Bessou (2016)

2.2 Time modelling in the inventory

The net C_{bio} balance from sequestration and releases add up to zero at some point in time, yet the C_{bio} flows are temporally differentiated and thus distributed over the entire rotation period and EOL releases of the PKO. The rotation length of oil palm plantations varies typically between 20 and 30 years (Henson, 2004), whereas a mean rotation cycle of 25 years is used in this work.

The first harvest year of the fresh fruit bunch (FFB) starts in year 4 (Khamis et al., 2005) and ends with the final rotation cycle in year 25. The harvesting activities are thus carried out each year, where the FFB is further processes at mill and delivered to the refinery for the production of the surfactant.

Starting with the first harvest, biomass residues are generated and incorporated to the soil annually contributing to SOC. The final year (25) represents the end-year of the rotation length with additional contributions of stem and roots to SOC.

No temporal dynamic is accounted for during the use phase (regarding carbon storage and emission delay) and the EOL releases are assumed to be instantaneous, i.e. the consumption of the SLES in the final product (shampoo or shower gel) represents the EOL estimated to occur in the same year of the manufacturing of the SLES with no further time lags.

Fig. 2a. shows the C_{bio} life cycle inventory of the oil palm cultivation and harvest activities over 25 years. C_{bio} sequestration is modelled for the 25-year cycle (including SLES manufacture, use and EOL) by applying the following approach illustrated in Fig. 2b.: an inventory year (t_{inv}) represents a mixed production system aged between 4 and 25 years and the corresponding timeframe is spread over 46 years. SOC flows follow the same approach, however stem and root fraction represent a temporary carbon storage and with the final harvest in year 25, the dead biomass is incorporated in the soil. Furthermore, all inventoried life cycle C_{bio} flows of the palm oil plantation are attributed to the harvest activity proportionally to the annual yields (i.e. annual harvest of FFB divided by the cumulative sum of all FFB yields of the 25-year cycle).

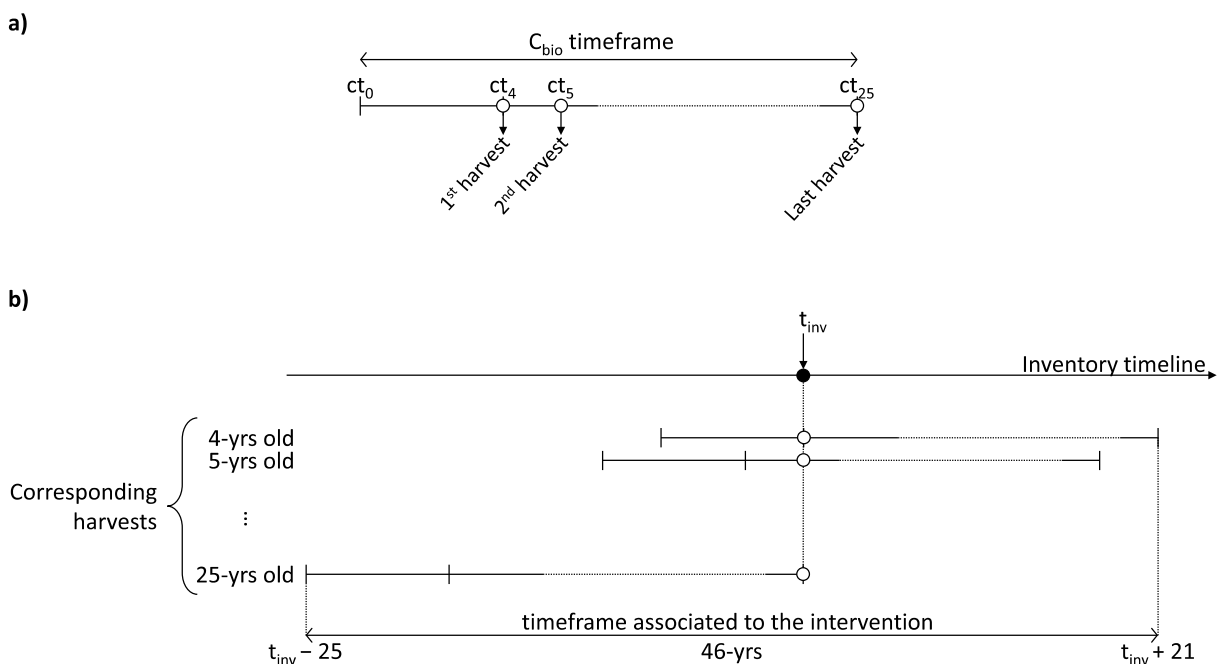

Fig. 2. Modelling scheme of a) the dynamic of an oil palm plantation and b) corresponding dynamic of palm kernel oil consumption (at the instant t_{inv})

2.3 Product specifications and functional unit

SLES is a secondary oleochemical derivative. For this study, we analysed a partially petroleum- and biomass-sourced surfactant (Fig. 3) produced by the French chemical company Solvay. The molecule consists of C16 C-chain fatty alcohol $[\text{CH}_3(\text{CH}_2)_{11}(\text{OCH}_2\text{CH}_2)_2\text{OSO}_3\text{Na}]$, whereof C12 are PKO-sourced (i.e. to 75% bio-sourced). The molecular weight of the compound is $376.49 \text{ g}\cdot\text{mol}^{-1}$ and the final product is diluted in water to 70%. The equivalent CO_2 content of the C16 C-chain (non-diluted in water) is about $1.87 \text{ kg CO}_2\text{-eq}\cdot\text{kg}^{-1}$ SLES ($16 \cdot 44.009 / 376.49$).

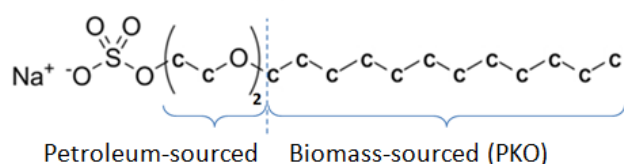

Fig. 3. Sodium lauryl ether sulphate molecule

A comparison of the main refining process pathways of fatty alcohols from PKO and petroleum-based feedstocks is shown in Fig. 4. The PKO-sourced processes involve hydrolysis of PKO into fatty acids, its conversion into methyl ester and finally its hydrogenation into fatty alcohol. The conversion yield of PKO to fatty alcohol is 0.999:1 (Shah et al., 2016). The final product contains 0.42 kg fatty alcohol per kg of product. The Cbio balance is aligned to these conversion factors. Regarding the goal and scope of this case study (exploring dynamic Cbio models), all data and conversion estimates of the surfactant SLES consists of a simplified representation of the product.

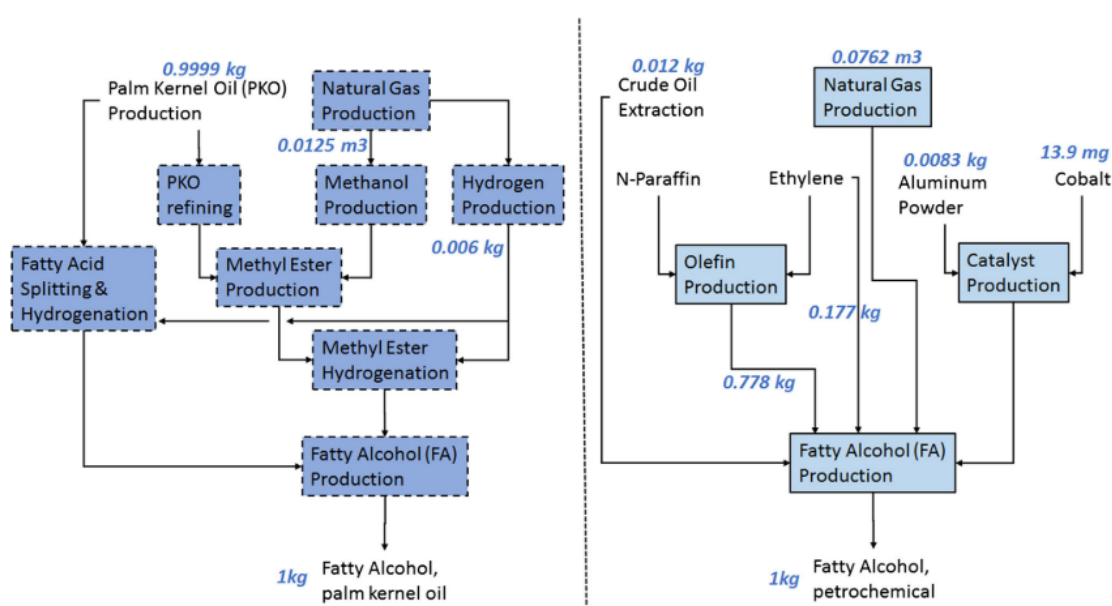

Fig. 4. Value chain of fatty alcohol from palm kernel oil- and petroleum-based feedstocks. Source: (Shah et al. 2016)

2.4 Dynamic upstream modelling

2.4.1 Modelling framework and assumptions

The dynamic upstream modelling is aligned with the carbon modelling framework proposed by Henson (2004), however involving dynamic SOC. The dynamic upstream flows are closely interlinked with the fresh fruit bunch (FBB) mill processes, as with its co-products, such as palm oil mill effluents (POME), mesocarp fruit fibres (MFF) and empty fruit bunches (EFB), are commonly returned to the field as organic fertilisers, mulching material and soil amendments (C. Bessou, pers. comm., 2019).

The C_{bio} fixation model involves all crop fractions of the standing living biomass. The SOC model, on the other hand, comprises SOM from the dead biomass contributing to C inputs to the soil from pruning and shedding of FBB, POME, EFB, as well as the dead roots and stem biomass, are left-behind at the end of the rotation period.

The retained modelling assumptions were obtained from literature in the context of oil palm plantations in Indonesia and Malaysia, and personal communication with Cécile Bessou, as follows:

- Planting density varies considerably, yet in Indonesia and Malaysia common densities are between 142 to 148 palm trees per ha (Martinez et al., 2017; Sung, 2016), for the model assuming a mean value is used (145 palms·ha⁻¹).
- FBB comprises leaflets, rachis and petiole in the proportions of 0.29:0.29:0.42 (Henson and Chang, 2007). About 80% of the total frond biomass is pruned, according to Henson (2004). Additionally, palm trees shed their fronds naturally (from about year 5). Both pruned and shed fronds represent litter contributing to soil organic matter (SOM), modelled separately.
- Male inflorescence plant biomass (MIPB) is included in the C_{bio} balance for the sake of completeness, even though the C_{bio} in the biomass represents a small fraction of the total crop biomass, ranging between 0.8% and 1.4% (Henson, 2004).
- FFB is the crop product, amounting 20% of the total standing biomass, according to data collected in Indonesia (Sung, 2016). FFB is further processed at mills for the extraction of crude palm oil (CPO) and palm kernel oil (PKO). Mill main products, co-products and emissions depend on the FFB yield:
 - CPO and PKO final crop products, account for about 21% of the FFB (Sung, 2016), representing about 10% of total palm tree. Mean PKO yields account for about 12% of FFB (Abdullah and Sulaiman, 2016; Berger, 2003).
 - POME co-product, estimated at 58% of FFB (Sung, 2016), is difficult to assess, as it is site-specific concerning the processes employed in each mill.

- EFB co-product, estimated at 22% of FFB (Sung, 2016), is uniformly applied in the model.
- Palm kernel shell (PKS) co-product, represents 6% of FFB (Sung, 2016)
- Mesocarp fruit fibre (MFF) co-product, represents 15% of FFB (Sung, 2016)

All co-products, except for PKS (here assumed to be incinerated at mill for on-site energy generation), are thus returned to the field as organic fertilisers and mulching material/soil amendment. Other SOM sources are the stem and the root system, as well as non-pruned FBB, all of which remain at the field until the end of the rotation length (year 25), representing a temporary carbon stock. At the end of the cycle, the stem is chopped or shredded (here we assumed shredding) to accelerate its decomposition processes and the mineralisation of nutrients.

Moreover, CH₄ emissions deriving from anaerobic pond treatment of POME are accounted for at 12.36 kg CH₄·t⁻¹ POME, based on the estimates by Yacob et al. (2006). Other CH₄ values were not found in literature. It is assumed that CH₄ is not collected for energy recovery, and thus directly emitted to the atmosphere. Other CH₄ sources are not accounted for in the dynamic C_{bio} model, yet they may arise from peat and waterlogged soils (Henson, 2004).

The dynamic C_{bio} model excludes site-specific modelling assumptions, concerning unexpected events (e.g. diseases and pests, wild fires, mortality), nutrient cycling (as the focus lies on the carbon flows only), and C_{bio} inputs to the soil from other exogenous sources (e.g. leguminous cover crops often applied in oil palm plots). Moreover, changes due to land transformation or management are not modelled. However, CO₂ emissions from land transformation are considered in the original LCA study (in which this study is based on), and thus included in the static final GHG emission results.

2.4.2 Modelling mean palm growth and carbon fixation

Dynamic C_{bio} modelling of the oil palm fractions follows the same approach from previous studies concerning forest tree modelling (Albers et al., 2019b). The model estimates are based on secondary data from destructive methods and/or empirical studies. Fig. 5 provides an overview of mean oil palm growth development models and allometric relation to estimate biomass accumulation per crop fraction as a function of time (age).

For modelling the correlation between age and height (Age-H) as well as age and diameter-breast-height (Age-DBH) of oil palm, data was retained from field studies (2011-2012) by Tan et al. (2014), tabulated in Appendix G: SM of Manuscript . The sampling accounted for 118 plots (22 m · 22 m) with different age classes within three estates in the Peninsula Malaysia, covering about 50% (2.56 Mha) of the total oil palm production in the country.

Age-H mean values were fitted by means of non-linear regression using the Chapman's Richards (CR) model, previously applied to predict mean forest tree growth (Albers et al., 2019b). The same initial non-self-starting parameters were used, with 0.02 for k , 2 for p and A twice the maximum age (i.e. 50 years for oil palm). The model proved to be applicable for oil palm with strong goodness of fit ($GoF = 1$), as shown in Fig. 5a. Yet, the CR model is not applicable for Age-DBH, because DBH barely changes over time and therefore the correlation with age is weak. Parameters were fitted with linear ($R^2 = 0.995$) and exponential ($R^2 = 0.995$) models, both models demonstrating a strong correlation, as shown for the linear fit in Fig. 5b.

For the C_{bio} modelling of other crop fractions, a comparison between different models from Henson et al. (2012), Corley and Tinker (2003), Khamis et al. (2005), (Syahrudin, 2005), Tan et al. (2014), and Sung (2016) was undertaken, when applicable, involving the following crop fractions: aboveground stem (Fig. 5c), FFB (Fig. 5d), FBB (Fig. 5e), shed FBB (Fig. 5f), MIPB (Fig. 5g), and belowground roots (Fig. 5h).

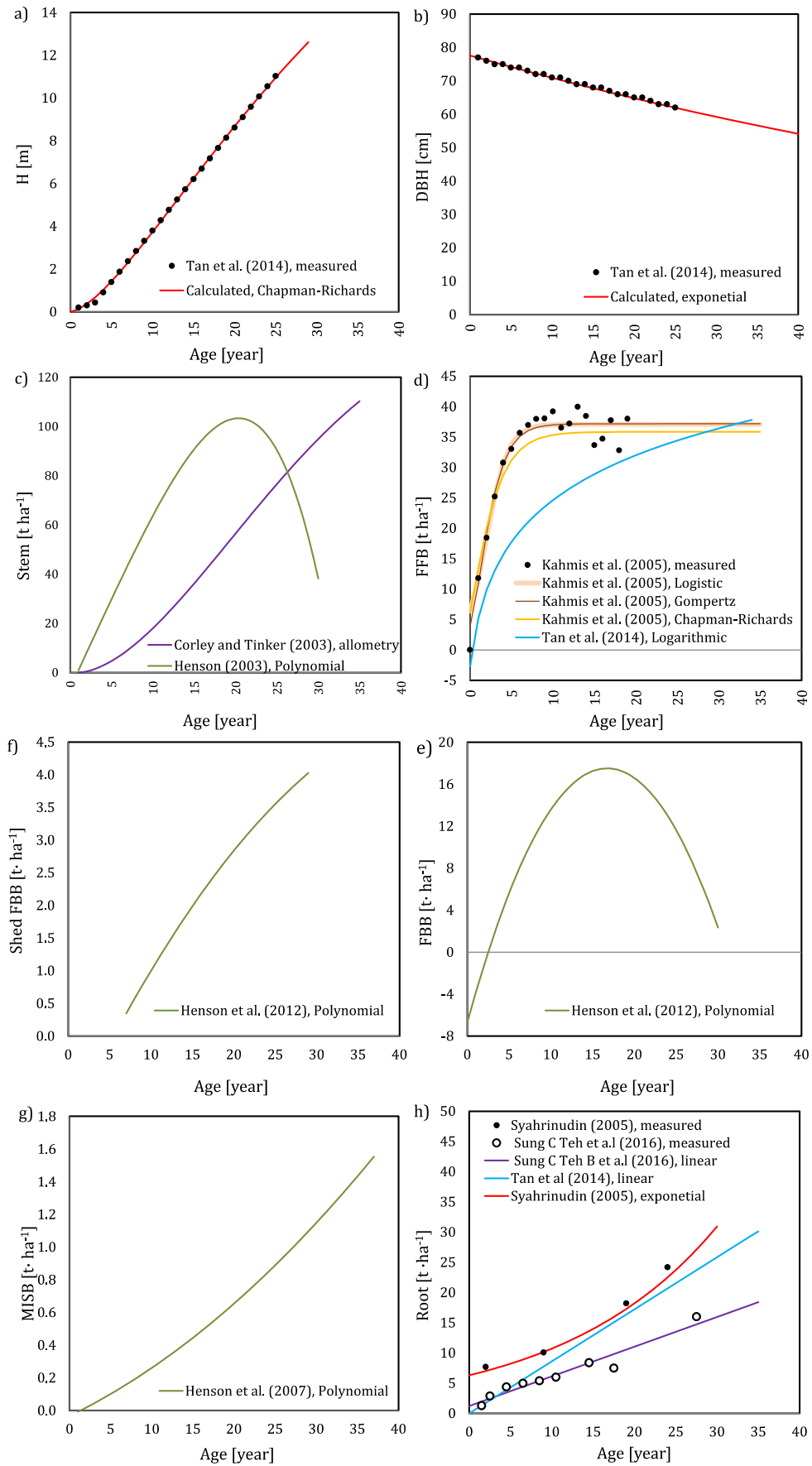

Fig. 5. Estimation of mean oil palm growth development and carbon fixation of different crop fractions, measured vs. fitted data

Table 1 lists all selected models and their respective parameters. For the sake of simplification all parameter notations are expressed as a (replacing A), b (replacing k) and c (replacing p). The carbon contents per crop fraction retained in this study, from Sung, (2016), range between 32% and 49% (Table 2.1), with the mean value calculated at 45%. Other values vary between 40% and 57.6%. According with Henson (2004) the approximation of carbon content remains a source of uncertainty, as further measurements are required.

Table 1. Model and parameter estimates for oil palm crop fractions including carbon content

Crop fractions	Model selection	Model parameters			C-content
		a	b	c	
H	$y(t) = a(1 - \exp^{-bt})^c$	25.840	0.035	1.578 ^a	N/A -
DBH	$y(t) = a \exp^{-bt}$	77.578	0.009	N/A ^a	N/A -
Stem	$y(t) = \pi(a \text{ DBH}^2 \times H(bt + c))$	0.777	0.001	0.003 ^b	34% ^c
FBB	$y(t) = a/1 + b \exp^{-ct}$	37.08	4.810	0.780 ^c	45% ^c
FFB	$y(t) = at^2 + bt - c$	-0.086	2.893	-6.696 ^d	49% ^e
Shed FBB	$y(t) = at^2 + bt - c$	-0.003	0.267	-1.638 ^d	49% ^e
MIPB	$y(t) = at^2 + bt - c$	0.001	0.024	-0.034 ^d	45% ^e
Roots	$y(t) = a \exp^{-bt}$	6.307	0.053	N/A ^a	45% ^e
POME	N/A	N/A	N/A	N/A	32% ^e
EFB	N/A	N/A	N/A	N/A	49% ^e

Abbreviations: H: Height, DBH: Diameter Breast Height, FFB: Fresh fruit bunch, FBB: Frond Base Biomass, MIPB: Male Inflorescence Plant Biomass; N/A: not applicable

Sources: ^a Tan et al. (2014), ^b (Corley and Tinker, 2003), ^c Khamis et al. (2005), ^d Henson et al. (2012), ^e (Sung, 2016) with 0.45 t C·t⁻¹ representing the calculated mean value

The selection of the multiple compared models (in Fig. 5c, d, h), is based on the following reasons: The allometric relations for stem mean growth has a better representation in terms of stem growth, as the polynomial approximation converges to unrealistic negative values. For FFB yield the logistic model by Khamis et al. (2005) is chosen, because it is first ranking according to the authors, although the yield estimates are high peaking with 37 t·ha⁻¹. The logarithmic model by Tan et al. (2014), on the other hand, does not represent the yield curve accurately, as the values continue rising even for mature palm trees. However, yield is age-dependent, decreasing towards the end of the rotation length the more mature the palm tree becomes (Henson, 2007).

In general, polynomial models predict smooth growth curves within the linear modelling framework. However, the models face challenges regarding the interpretation of parameters, and the unrealistic growth predictions with negative mass values upwards and downwards. Therefore, these traditionally used growth functions, namely linear (referring to constant absolute plant growth) and exponential (referring to loglinear with constant RGR) models, are not recommended (Paine et al., 2012). Nonlinear predictions are increasingly recognised in growth analysis since fitting parameters using nonlinear regression have matured, better capturing the temporal dynamic/variability of growth (i.e. dependency of growth in age-and size) (Archontoulis and Miguez, 2015; Paine et al., 2012).

This study is limited to the use of existing models from literature due to lacking primary or experimental data on specific oil palm fractions (e.g. frond base biomass). Future studies should stress on further exploring modelling improvements for mean growth development of different oil palm crop fractions, to provide more accurate predictions and thus enhance the modelling of C_{bio} sequestration dynamic.

2.4.3 Modelling soil carbon

The SOC modelling framework developed in Albers et al. (2019d), based on the pioneering model by Hénin and Dupuis (1945), was used. As described in the previous study, the SOC model describes the C inputs to the top soil from the dead biomass at a given time and the C losses/releases over time due to degradation. All C inputs are returned to the atmosphere, denoting a temporary sequestration, until the SOC balance equals zero.

The dynamic SOC approach models the C inputs to the soil from aboveground (AG) and belowground (BG) compartments separately. The AG biomass accounts here for FBB, MIPB, stem, including co-products from the mill POME, EFB, and MFF, while the BG for the root system. The discrete treatment of both AG and BG allows modelling biomass feedstocks with rotation lengths >1 year, such as perennial oil palm species, implies that some biomass fractions are not added to the soil the same year they are harvested. Oil palm stem and roots are accounted for at the end of the rotation length. Other biomass fractions are added to the soil annually, starting from the first year of FFB harvest (i.e. year 4).

The humification coefficient (h) is estimated at 0.3 for all crop residual fractions, except for POME, EFB, and MFF, estimated at about 0.7 (Bonten et al., 2014). Moreover, values for the mineralisation rate or decomposition (k , not to be confused with the k parameter of palm tree partitioning, yet both referring the negative exponential decay rate), representing the decomposition rate constant, are retrieved from studies in Indonesia (Gao et al., 2016; Sung, 2016) (Table 2). The carbon content is predefined by the growth and sequestration curve (Table 2).

Table 2. Soil organic carbon parameters

Crop fractions	Humification coefficient (h) ^a	Mineralisation coefficient (k) ^b
	[unitless]	[yr ⁻¹]
Leaflets	0.3	0.26
Rachis	0.3	0.12
Petiole	0.3	0.15
Stem (shredded)	0.3	0.11
Male inflorescent	0.3	0.26
Roots	0.3	0.07
Palm oil effluent	0.7	0.26*
Empty fresh fruit bunch	0.7	0.20*
Mesocarb fruit fibre	0.7	0.26*

Sources: ^a (Bonten et al. 2014), ^b (Gao et al. 2016; Sung 2016), * estimated values

3 Results and discussion

3.1 Dynamic biogenic carbon flows and temporal distribution

Fig. 6 shows the dynamic inventories [t C·ha⁻¹] of C_{bio} fixation modelled by means of biomass growth per crop fraction (Fig. 6a) and the respective proportions of C_{bio} added to the soil modelled by means of SOC degradation (Fig. 6b).

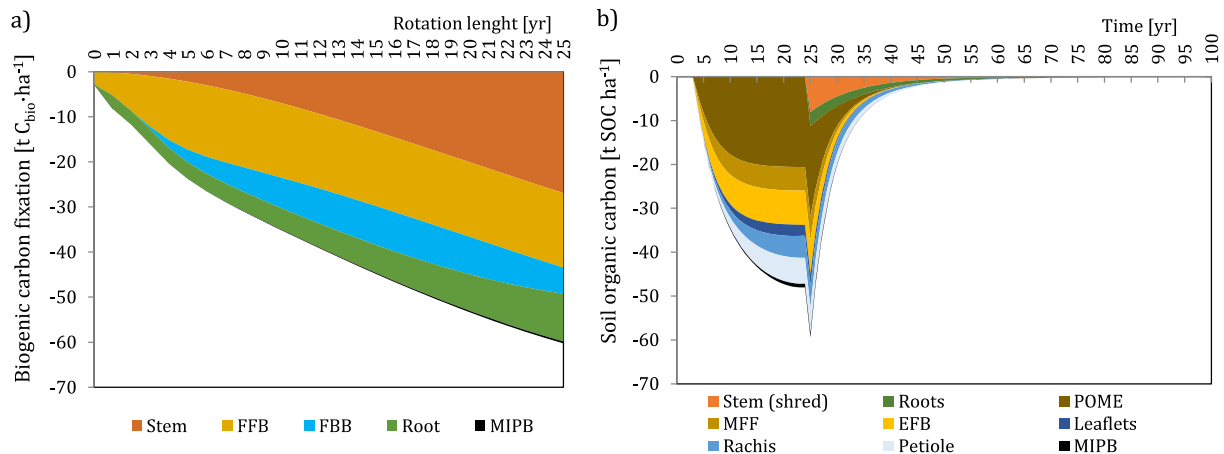

Fig. 6. Oil palm upstream flows from a) dynamic biogenic carbon (C_{bio}) fixation from different plant fractions over the rotation length, and b) soil organic carbon (SOC) including mill co-products over the assessment period

The C_{bio} fixation and SOC dynamic represent almost 90% of the total oil palm biomass, the remaining flows are associated with instantaneous release flows from PKS incineration (~4%) and EOL of PKO in SLES product (~1%). No particular C_{bio} dynamic is associated to the use and EOL phases, occurring both within a one-year time step. The temporal variability of the C_{bio} flows is thus exclusively

associated with the upstream modelling phase (all C_{bio} values are provided in Appendix G: SM of Manuscript).

Mean annual FFB harvested over the 25-year rotation length was estimated at about 4.55% of total aboveground biomass, starting in year 4, based on which the harvest activity of the dynamic flows is allocated.

Fig. 7a. shows the dynamic flows resulting from C_{bio} fixation, SOC balance, PKS incineration and EOL releases from SLES use, where the curve represents the integral of the dynamic full lifetime accounting balance [t C] in Fig. 7b. divided by mean annual yields to obtain the annual C_{bio} elementary flows [t C·yr⁻¹] that can be coupled with the amount of palm oil used in the end-product.

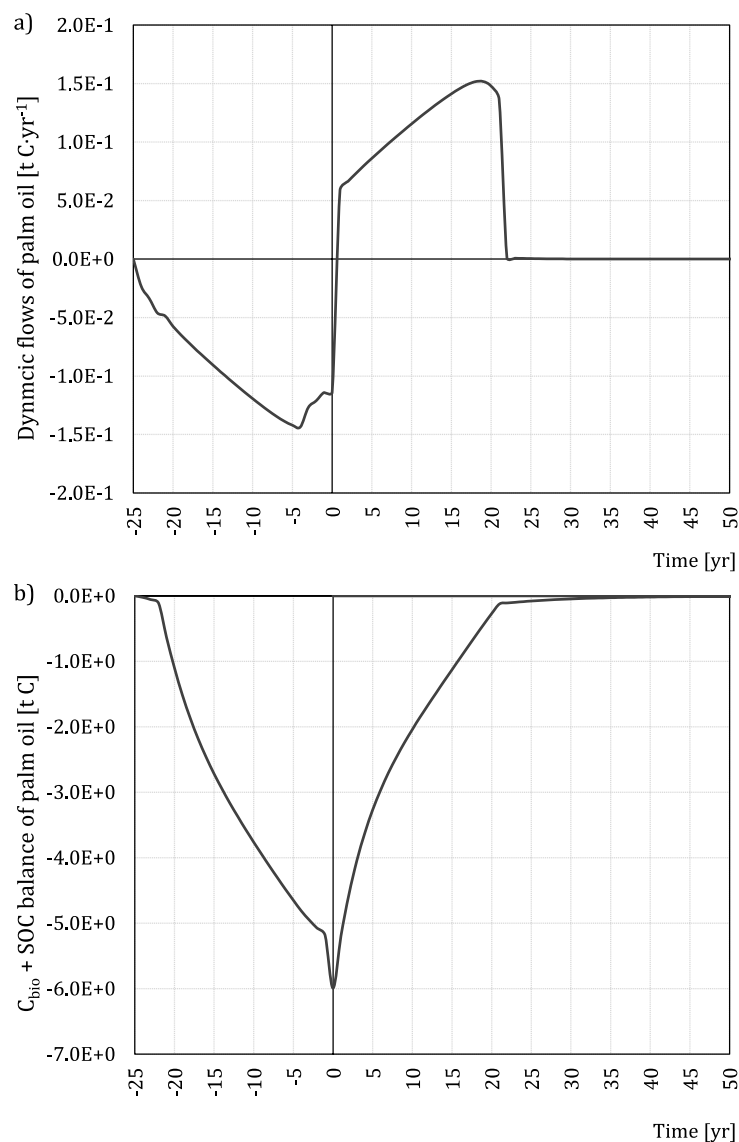

Fig. 7. Full lifetime carbon accounting flows oil palm surfactant product life cycle a) dynamic full lifetime carbon accounting flows [t C·yr⁻¹] for oil palm surfactant product life cycle computed from b); b) dynamic biogenic carbon (C_{bio}) and soil organic carbon (SOC) balance [t C]

3.2 Dynamic impact assessment

The dynamic carbon flows (in Fig. 8a) are converted into CO₂ and CH₄ elementary flows, multiplying them by the molecular weight conversion factors 44/12 for CO₂ and 16/12 for CH₄, to subsequently assess the time-dependent climate change impact assessment (Levasseur et al., 2010). Fig. 8 shows the instantaneous radiative forcing (RF) in W·m⁻² (Fig. 8a), its integral as the cumulative RF in W·yr·m⁻² (Fig. 8b), and the relative RF in kg CO₂-eq (Fig. 8c), per tonne of palm oil consumed via the SLES surfactant product pathway, i.e. accounting for no temporary storage in the use phase and instant EOL releases. The timeline starts in year -25 due to the dynamic oil palm modelling approach applied in this study (see Fig. 2).

The relative impact results in negative emissions of -2.58 and -1.07 kg CO₂-eq per kg of PKO over the fixed reference years $t = 20$ and $t = 100$ respectively, denoting climate benefits from the life cycle pathways of SLES. The chosen fixed years are adapted to the time horizons (TH) from the static IPCC GWP factors. The end-year is set by counting from the last dynamic inventory flow ($C_{\text{bio}} + \text{SOC}$) in the year 25, as illustrated in Fig. 2, to avoid temporal inventory cut-offs and englobe the forcing effects from the last emission flow. Fixing an end-year in the dynamic impact assessment by defining an LCIA TH equivalent to the static C-neutral results allows a comparison between the two approaches (details provided in Albers et al., (2019b)).

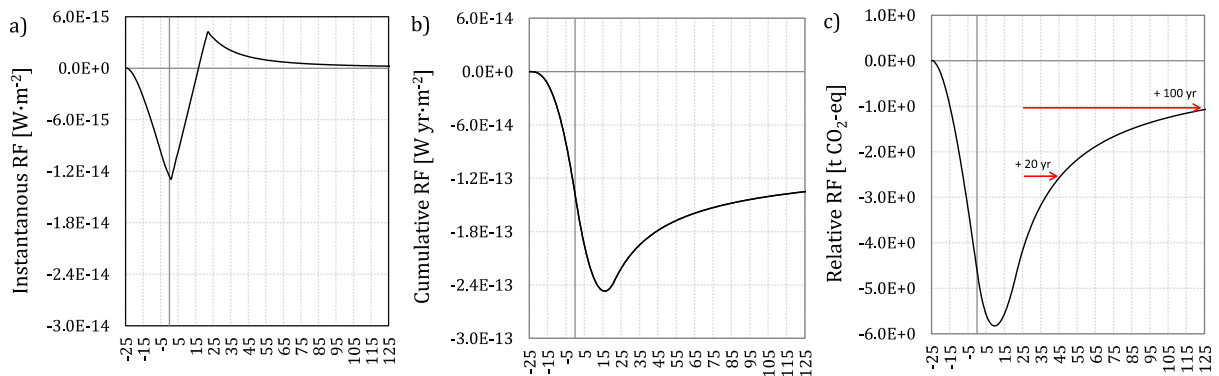

Fig. 8. Dynamic impact assessment per tonne of oil palm consumed and SLES product pathway

3.3 Comparison of GHG emissions from SLES and sensitivity analysis

The time-dependent annual C_{bio} impact factors [t CO₂-eq·t⁻¹] can be coupled with any technical flow by scaling them to the amount of PKO feedstock consumed in the end-product (here SLES). Thus, applying the dynamic C_{bio} factors to the surfactant inventory, namely 0.42 kg PKO per kg SLES, the biogenic GHG emissions are negative with -1.08 and -0.45 kg CO₂-eq·kg⁻¹ SLES over 20 and 100 years, respectively.

The C-neutral results from the static LCA study were estimated at 1.77 kg CO₂-eq·kg⁻¹ SLES with GWP factors over 100-years. By summing up the static and dynamic results, both over the same LCIA TH (here 100 years), a comparison can be undertaken between C-neutral and complete carbon (C-complete) impacts. C-neutral is lower by 25% (1.32 kg CO₂-eq) due to the full lifetime accounting of oil palm sequestration and release flows. Setting the LCIA TH from year -25 to 75 would result in 1.07 kg CO₂-eq·kg⁻¹ or from years 0 to 100 in 1.22 kg CO₂-eq·kg⁻¹, with a difference to the static value of 40% and 31% respectively. Which LCIA TH to choose for the comparison with the static results is critical, as the C-complete results may vary significantly. However, it is recommended to account from the year of the last emission of the dynamic inventory to assess the effects from all C_{bio} and SOC emission flows.

C-complete results can vary due to the modelling assumptions from the C_{bio} balance. Therefore, a sensitivity analysis was performed to test the variations in the C-complete results due to changes in the model parameter. Minimum and maximum possible key parameter values were tested, namely variations in mean FFB yield (8 - 40 t·ha⁻¹), rotation length (20 - 30 years), palm density (100 - 200 trees·ha⁻¹), and the decomposition rate constant (*k*) (multiplied by 2 or by 0.5), as shown in Fig 9.

The mean FFB yield modelled in this study was 36 t·ha⁻¹, which is higher than most of the values reported in literature for Indonesia and Malaysia, whose range lies between 17 and 25 t·ha⁻¹ (Choo et al., 2011; Corley and Tinker, 2003; Henson, 2007; Schmidt, 2007; Shah et al., 2016; Woittiez et al., 2017). However, more recent studies on the yield gaps of oil palm have reported attainable yields at 26-31 t FFB·ha⁻¹ in Southeast Asia (Hoffmann et al., 2017) and comparing with other regions of the world between 8 and 40 t·ha⁻¹ (Woittiez et al., 2017), which make the yield estimates very uncertain due to several influencing factors (e.g. geographical location, management practices, etc.). The sensitivity analysis demonstrated that systems with lower FFB yields feature significantly lower climate benefits from C_{bio} modelling and vice versa.

Concerning the rotation length or replanting cycles of oil palm plantations, the 25-year cycle has been set as a default parameter by RSPO certification scheme (Bessou, 2016), and is the most used estimate (Choo et al., 2011; Schmidt, 2007). Yet the cycles may vary between 20 and 30 years (Henson, 2004). From the sensitivity analysis, it was identified that longer rotation lengths increase, while shorter decrease the net climate benefit from C_{bio}. Nonetheless, as abovementioned, yields are affected by palm maturity, which has an economic impact on the long run.

Changes in the number of palms per hectare also influence the computation of C_{bio} benefits via the C-complete results. Increasing the density implies higher climate benefits, while decreasing it revealed the opposite. However, higher densities lead to higher vulnerability to mortality, for instance, due to water deprivation during dry seasons (Corley and Tinker, 2003; Sung, 2016; Wang et al., 2017).

The sensitivity results demonstrated that increasing yield, rotation length and number of palms slightly contribute to higher climate mitigation effects, attributed to higher C_{bio} values sequestered in the biomass over a longer period of time. The largest variation is given by decreasing yields, as the computation of the dynamic flows is dependent on this variable. The results are thus sensitive to the yields. In contrast, variations in the decomposition rate constant (k) do not contribute to changes and are thus within statistical error.

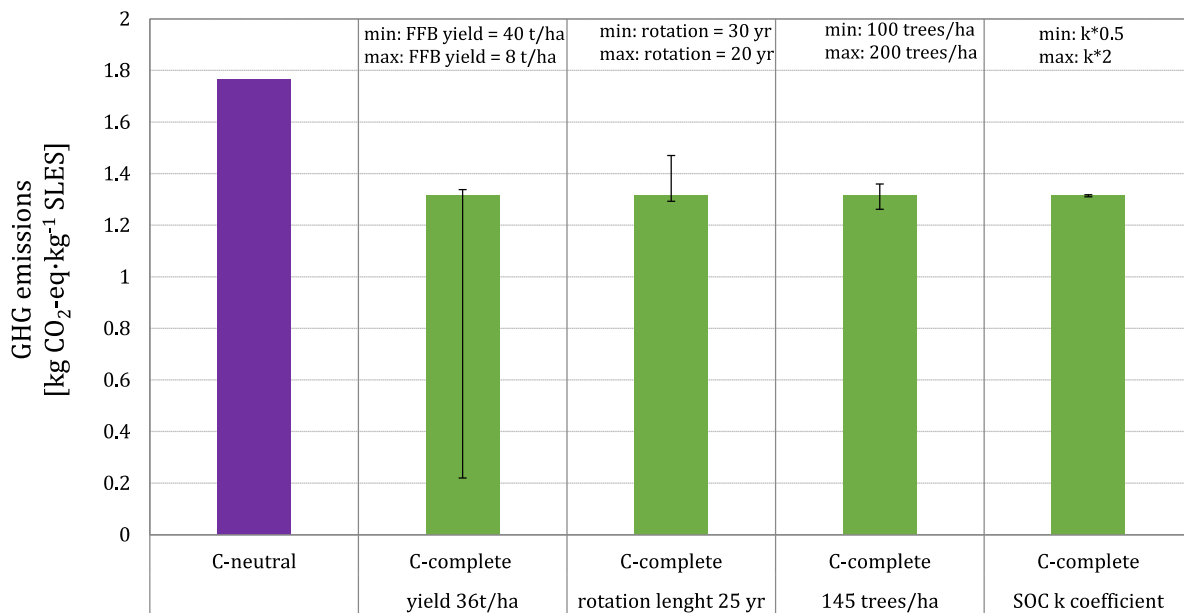

Fig. 9. GHG emission of SLES under carbon neutral and complete carbon estimates, with sensitivity analysis

3.4 Scenario comparisons of dynamic biogenic impacts from oil palm

Moreover, a scenario comparison was performed by modifying the assumptions undertaken for C_{bio} - CH_4 releases arising from POME, the product service life and EOL emissions to assess potential variations in GHG emissions associated with dynamic flows from oil palm. The results are not directly linked with the SLES surfactant, but rather highlight the effect of changes in the C_{bio} results due to changes in the estimates or release pathways of the dynamic C_{bio} model.

The modifications carried out are as follows. For POME CH_4 releases, it was assumed that a) 100% is collected for energy recovery and emitted as CO_2 to the atmosphere and b) CH_4 emissions from POME are twice the amount estimated by Yacob et al. (2006), i.e. at $24.72 \text{ kg } CH_4 \cdot t^{-1}$. Moreover, a service life of 10 and 20 years was assumed as a temporary delay of C_{bio} emissions embedded in bio-products (e.g. bioplastics from oil palm feedstock). Finally, the EOL was assumed not to emit GHG instantaneously, but gradually due to decomposition processes (pertaining no dynamic in the use phase like the original assumptions).

Fig. 10 shows the relative GHG emissions assessed with the time-dependent characterisation factors over the LCIA THs of 20 and 100 years. The original values (-2.58 and -1.07 $\text{kg CO}_2\text{-eq}\cdot\text{kg}^{-1}$ palm oil over 20 and 100 years respectively) are based on the modelling pathway of the SLES surfactant. A general overview of the scenario comparisons with the original C_{bio} results, shows, as highlighted in previous studies (Albers et al., 2019a, c, d), that the C_{bio} benefits decrease with increasing TH. The C_{bio} balances (if no permanent sequestration is considered) converge to zero at some point in time. Thus, the variations between the 100-year results are less significant than those over the LCIA TH 20 years.

When CH_4 releases are increased by a factor of 2, the negative impacts increase by 4% (-2.57 $\text{kg CO}_2\text{-eq}\cdot\text{kg}^{-1}$ PKO) compared with the original in the short-term (LCIA TH 20 years), most likely deriving from the higher radiative forcing effects from the short-lived gas, yet less significant (1% of the original value) for the LCIA TH 100 years (-1.09 $\text{kg CO}_2\text{-eq}\cdot\text{kg}^{-1}$ PKO). The service life, on the other hand, demonstrated almost the same results as the original values with differences between 0.13 and 0.44%. The negligible impacts of temporary sequestration and delay due to the consideration of service life (>1 year) are due to the low proportions from FFB yield biomass ($\sim 4.55\%$) to the total palm biomass. The EOL decay assumptions produce higher negative forcing effects, by 8% for LCIA TH 20 (-2.77 $\text{kg CO}_2\text{-eq}\cdot\text{kg}^{-1}$ palm oil) and 100 (-1.16 $\text{kg CO}_2\text{-eq}\cdot\text{kg}^{-1}$ palm oil) years respectively, as compared with the original values. It is attributed to the releases over a longer period than for instantaneous emissions.

Overall scenario comparisons demonstrated that GHG emissions from the original dynamic palm oil impacts do not significantly differ due to modifying the C_{bio} pathways concerning releases due to CH_4 , service life or EOL. The largest variation was given by the EOL decay assumptions as compared to the original EOL instantaneous releases.

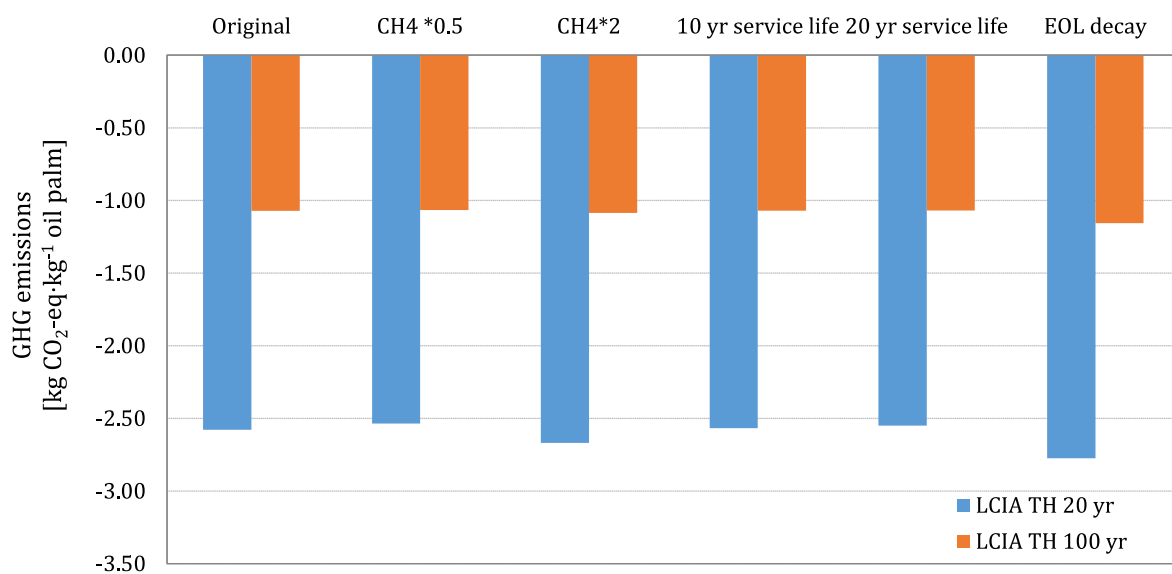

Fig. 10. Scenario comparison with modification of C_{bio} model assumptions and pathways

4 Conclusions

This study was concerned with full lifetime accounting applied to a partially oil palm-sourced surfactant used in personal care products by means of a model integration approach coupling a conventional LCA with dynamic C_{bio} models. The purpose was to include the dynamic flows in the static assessment of GHG emissions. The dynamic C_{bio} inventories consisted of modelling growth and C_{bio} sequestration of all crop fractions from oil palm, involving SOC dynamic from the biomass return to the soil, and the further processing pathways into the surfactant and final C_{bio} releases at the end-of-life.

The C_{bio} impact per kg SLES resulted in $-1.086 \text{ kg CO}_2\text{-eq kg}^{-1}$ SLES (or $-0.45 \text{ kg CO}_2\text{-eq kg}^{-1}$ PKO), which has been aggregated to the C-neutral estimates from the LCA study, reducing the GWP results by 25%. The computed negative emissions are sensitive to the chosen LCIA TH. The combination of the static and dynamic results is possible, as long as the same unit and temporal boundary are considered. Yet, it does not represent a full dynamic study, as the fossil-sourced inventories were computed with the static GWP metric, which delivers inconsistencies with the actual climate change impacts under consideration of the time dynamic carbon footprints. Moreover, disaggregated inventories (i.e. elementary flows) were not available. General conclusions on higher mitigation potentials could be drawn from increasing FFB yields, palm planting density and rotation lengths, due to higher C_{bio} sequestration over a longer period. Yet, whether this is realistically achievable is questionable. Moreover, scenario developments modifying the SLES pathway (e.g. involving time lags in the use phase), have not significantly affected the results.

The climate benefits computed from the full lifetime C_{bio} flows are significant for the SLES surfactant pathway. For other products with considerable higher PKO requirements per unit of product or for the assessment of C_{bio} flows at larger scales (e.g. at landscape, national level), dynamic full lifetime accounting of C_{bio} might result in noteworthy climate mitigation potential.

The proposed dynamic modelling C_{bio} approach for perennial oil palm species provided good approximations, when primary data from samplings or field measurements are not available or specifically required. It is consistent with an attributional LCA modelling context, where mean estimations are standard. The evaluation of the environmental profiles of the oil palm system should, however, encompass all other effects associated with deforestation, peat oxidation, land use change and biodiversity. Site-specific (i.e. spatial-dynamic of the modelling data) variability should be further refined for case specific studies.

Acknowledgements

The authors would like to acknowledge the collaboration with Solvay and the valuable inputs from Cécile Bessou (CIRAD).

References for Manuscript 4

- Abdullah, N., Sulaiman, F., 2016. The Oil Palm Wastes in Malaysia, in: Matovic, M.D. (Ed.), *Biomass Now - Sustainable Growth and Use*. p. 13. <https://doi.org/http://dx.doi.org/10.5772/57353>
- Albers, A., Avadí, A., Benoist, A., Collet, P., Hélias, A., 2019a. Modelling dynamic soil organic carbon flows of annual and lignocellulosic perennial energy crops to inform techno- economic energy-transport scenarios in France. *Int. J. Life Cycle Assess.* [under Rev. 1-28].
- Albers, A., Collet, P., Benoist, A., Hélias, A., 2019b. Data and non-linear models for the estimation of biomass growth and carbon fixation in managed forests. *Data Br.* 23, 1–8. <https://doi.org/10.1016/j.dib.2019.103841>
- Albers, A., Collet, P., Benoist, A., Hélias, A., 2019c. Back to the future : Dynamic full carbon accounting applied to prospective bioenergy scenarios. *Int. J. Life Cycle Assess.* [under Rev. 1-27].
- Albers, A., Collet, P., Benoist, A., Nouvelles, I.F.P.E., Bois-pr, A. De, 2019d. Data and non-linear models for the estimation of biomass growth and carbon fixation in managed forests Arnaud H e. *Data Br.* 23. <https://doi.org/10.1016/j.dib.2019.103841>
- Albers, A., Collet, P., Lorne, D., Benoist, A., Hélias, A., 2019e. Coupling partial-equilibrium and dynamic biogenic carbon models to assess future transport scenarios in France. *Appl. Energy* 239, 316–330. <https://doi.org/10.1016/j.apenergy.2019.01.186>
- Archer, S.A., Murphy, R.J., Steinberger-Wilckens, R., 2018. Methodological analysis of palm oil biodiesel life cycle studies. *Renew. Sustain. Energy Rev.* 94, 694–704. <https://doi.org/10.1016/j.rser.2018.05.066>
- Archontoulis, S. V., Miguez, F.E., 2015. Nonlinear regression models and applications in agricultural research. *Agron. J.* 107, 786–798. <https://doi.org/10.2134/agronj2012.0506>
- Berger, K., 2003. Palm Kernel Oil. *Encycl. Food Sci. Nutr.* <https://doi.org/10.1002/9780470114735.hawley12260>
- Bessou, C., 2016. PalmGHG, RSPO greenhouse gas calculator, scientific background. ICOPE Conf. 16-18 March 2016 – Bali – Indones. 22.
- Bessou, C., Chase, L.D.C., Henson, I.E., Abdul-manan, A.F.N., Milà, L., Agus, F., 2014. Pilot application of PalmGHG , the RSPO greenhouse gas calculator for oil palm products. *J. Clean. Prod.* 73, 136–145.
- Bonten, L., Elferink, E., Zwart, K., 2014. BioESoil Manual and background report. Alterra Wageningen, CLM Research and Advice Culemborg, Netherlands.
- Castanheira, É.G., Freire, F., 2017. Environmental life cycle assessment of biodiesel produced with palm oil from Colombia. *Int. J. Life Cycle Assess.* 22, 587–600. <https://doi.org/10.1007/s11367-016-1097-6>
- Chase, L., Henson, I., Abdul-Manan, A., Agus, F., Bessou, C., Canals, L.M. i, Sharma, M., 2012. The PalmGHG Calculator: The RSPO greenhouse gas calculator for oil palm products, Beta-version.

- Choo, Y.M., Muhamad, H., Hashim, Z., Subramaniam, V., 2011. Determination of GHG contributions by subsystems in the oil palm supply chain using the LCA approach 669–681. <https://doi.org/10.1007/s11367-011-0303-9>
- Corley, R., Tinker, P., 2003. *The Oil Palm*, Fourth. ed, Experimental Agriculture. Blackwell Science Ltd., Oxford. <https://doi.org/10.1017/s0014479700009066>
- Gao, H., Chen, X., Wei, J., Zhang, Y., Zhang, L., Chang, J., Thompson, M.L., 2016. Decomposition dynamics and changes in chemical composition of wheat straw residue under anaerobic and aerobic conditions. *PLoS One* 11, 1–17. <https://doi.org/10.1371/journal.pone.0158172>
- Hansen, S.B., Olsen, S.I., Ujang, Z., 2012. Greenhouse gas reductions through enhanced use of residues in the life cycle of Malaysian palm oil derived biodiesel. *Bioresour. Technol.* 104, 358–366. <https://doi.org/10.1016/j.biortech.2011.10.069>
- Hashim, Z., Subramaniam, V., Harun, M.H., Kamarudin, N., 2018. Carbon footprint of oil palm planted on peat in Malaysia. *Int. J. Life Cycle Assess.* 23, 1201–1217. <https://doi.org/10.1007/s11367-017-1367-y>
- Henin, S., Dupuis, M., 1945. Essai de bilan de la matière organique du sol. *Ann. Agron.* 1, 19–29.
- Henson, I. e, 2007. Modelling Oil Palm Bunch Components , Palm Oil and Kernel Yields. *Oil Palm Bull.* 55, 15–25.
- Henson, I.E., 2009. Modelling carbon sequestration and greenhouse gas emission associated with oil palm cultivation and land use change in Malaysia. A re-evaluation and a computer model. *MPOB Technol.* 31, 117.
- Henson, I.E., 2005. OPRODSIM, a versatile, mechanistic simulation model of oil palm dry matter production and yield., in: *Proceedings of PIPOC 2005 International Palm Oil Congress, Agriculture, Biotechnology and Sustainability Conference*. Malaysian Palm Oil Board, Kuala Lumpur, pp. 801–832.
- Henson, I.E., 2004. Modelling carbon sequestration and emissions related to oil palm cultivation and associated land use change in Malaysia. *MPOB Technol.* 27, 51.
- Henson, I.E., Betitis, T., Tomda, Y., Chase, L.D.C., 2012. The estimation of frond base biomass (FBB) of oil palm. *J. Oil Palm Res.* 24, 1473–1479.
- Henson, I.E., Chang, K., 2007. Modelling oil palm nutrient demand, nutrient turnover and nutrient balance. *MPOB Technol. No.* 30, 59.
- Hoffmann, M.P., Donough, C.R., Cook, S.E., Fisher, M.J., Lim, C.H., Lim, Y.L., Cock, J., Kam, S.P., Mohanaraj, S.N., Indrasuara, K., Tittinutchanon, P., Oberthür, T., 2017. Yield gap analysis in oil palm : Framework development and application in commercial operations in Southeast Asia Yield gap analysis in oil palm : Framework development and application in commercial operations in Southeast Asia. *AGSY* 151, 12–19. <https://doi.org/10.1016/j.agsy.2016.11.005>
- Huijbregts, M.A.J., Steinmann, Z.J.N., Elshout, P.M.F., Stam, G., Verones, F., Vieira, M.D.M., Zelm, R. Van, 2016. *ReCiPe2016 A harmonized life cycle impact assessment method at midpoint and endpoint level. Report I: Characterization*. Department of Environmental Science, Radboud University. Nijmegen.

Chapter 5: Agriculture: Soil organic carbon modelling

- IndexMundi, 2019. Data and Statistics [WWW Document]. URL <https://www.indexmundi.com/agriculture/?commodity=palm-oil&graph=production> (accessed 9.4.19).
- Khamis, A., Ismail, Z., Haron, K., Mohammed, A.T., 2005. Nonlinear Growth Models for Modeling Oil Palm Yield Growth. *J. Math. Stat.* 1 1.
- Koh, L.P., Miettinen, J., Liew, S.C., Ghazoul, J., 2011. Remotely sensed evidence of tropical peatland conversion to oil palm. *Proc. Natl. Acad. Sci. U. S. A.* 108, 5127–5132. <https://doi.org/10.1073/pnas.1018776108>
- Levasseur, A., Lesage, P., Margni, M., Deschênes, L., Samson, R., 2010. Considering time in LCA: Dynamic LCA and its application to global warming impact assessments. *Environ. Sci. Technol.* 44, 3169–3174. <https://doi.org/10.1021/es9030003>
- Martinez, S., Bessou, C., Hure, L., Guilbot, J., Hélias, A., 2017. The impact of palm oil feedstock within the LCA of a bio-sourced cosmetic cream. *J. Clean. Prod.* 145, 348–360. <https://doi.org/10.1016/j.jclepro.2017.01.042>
- Nasution, M.A., Wibawa, D.S., Ahamed, T., Noguchi, R., 2018. Comparative environmental impact evaluation of palm oil mill effluent treatment using a life cycle assessment approach: A case study based on composting and a combination for biogas technologies in North Sumatera of Indonesia. *J. Clean. Prod.* 184, 1028–1040. <https://doi.org/10.1016/j.jclepro.2018.02.299>
- OECD-FAO, 2013. *Agricultural Outlook 2013-2022: Highlights*.
- Paine, C.E.T., Marthews, T.R., Vogt, D.R., Purves, D., Rees, M., Hector, A., Turnbull, L.A., 2012. How to fit nonlinear plant growth models and calculate growth rates: An update for ecologists. *Methods Ecol. Evol.* 3, 245–256. <https://doi.org/10.1111/j.2041-210X.2011.00155.x>
- Patthanaissaranukool, W., Polprasert, C., Englande, A.J., 2013. Potential reduction of carbon emissions from Crude Palm Oil production based on energy and carbon balances. *Appl. Energy* 102, 710–717. <https://doi.org/10.1016/j.apenergy.2012.08.023>
- Rivera-Méndez, Y.D., Rodríguez, D.T., Romero, H.M., 2017. Carbon footprint of the production of oil palm (*Elaeis guineensis*) fresh fruit bunches in Colombia. *J. Clean. Prod.* 149, 743–750. <https://doi.org/10.1016/j.jclepro.2017.02.149>
- Schmidt, J.H., 2015. Life cycle assessment of five vegetable oils. *J. Clean. Prod.* 87, 130–138. <https://doi.org/10.1016/j.jclepro.2014.10.011>
- Schmidt, J.H., 2010. Comparative life cycle assessment of rapeseed oil and palm oil. *Int. J. Life Cycle Assess.* 15, 183–197. <https://doi.org/10.1007/s11367-009-0142-0>
- Schmidt, J.H., 2007. Life cycle assessment of rapeseed oil and palm oil Ph . D . thesis , Part 3 : Life cycle inventory of rapeseed oil and palm oil. Aalborg University Denmark.
- Shah, J., Arslan, E., Cirucci, J., O'Brien, J., Moss, D., 2016. Comparison of Oleo- vs Petro-Sourcing of Fatty Alcohols via Cradle-to-Gate Life Cycle Assessment. *J. Surfactants Deterg.* 19, 1333–1351. <https://doi.org/10.1007/s11743-016-1867-y>

- Stichnothe, H., Schuchardt, F., 2011. Life cycle assessment of two palm oil production systems. *Biomass and Bioenergy* 35, 3976–3984. <https://doi.org/10.1016/j.biombioe.2011.06.001>
- Sung, C.T.B., 2016. Availability , use , and removal of oil palm biomass in Indonesia.
- Syahrinudin, S., 2005. The potential of oil palm and forest plantations for carbon sequestration on degraded land in Indonesia, in: L.G.Vlek, P., Denich, M., Martius, C., Rodgers, C., Giesen, N. van de (Eds.), *Ecology and Development Series No. 28*. Cuvillier Verlag Göttingen, Göttingen, p. 108.
- Tan, K.P., Kanniah, K.D., Cracknell, A.P., 2014. On the upstream inputs into the MODIS primary productivity products using biometric data from oil palm plantations. *Int. J. Remote Sens.* 35, 2215–2246. <https://doi.org/10.1080/01431161.2014.889865>
- Vaskan, P., Pachón, E.R., Gnansounou, E., 2018. Techno-economic and life-cycle assessments of biorefineries based on palm empty fruit bunches in Brazil. *J. Clean. Prod.* 172, 3655–3668. <https://doi.org/10.1016/j.jclepro.2017.07.218>
- Wang, W., Chen, X., Tan, X., Wang, Q., Liu, Y., He, M., Yu, Q., Qi, W., Luo, Y., Zhuang, X., Yuan, Z., 2017. Feasibility of reusing the black liquor for enzymatic hydrolysis and ethanol fermentation. *Bioresour. Technol.* 228, 235–240. <https://doi.org/10.1016/j.biortech.2016.12.076>
- Woittiez, L.S., Wijk, M.T. Van, Slingerland, M., Noordwijk, M. Van, Giller, K.E., 2017. Yield gaps in oil palm : A quantitative review of contributing factors. *Eur. J. Agron.* 83, 57–77. <https://doi.org/10.1016/j.eja.2016.11.002>
- Yacob, S., Ali Hassan, M., Shirai, Y., Wakisaka, M., Subash, S., 2006. Baseline study of methane emission from anaerobic ponds of palm oil mill effluent treatment. *Sci. Total Environ.* 366, 187–196. <https://doi.org/10.1016/j.scitotenv.2005.07.003>

5.4 Chapter conclusion

Like for the study results of Chapter 4, this chapter revealed the importance of dynamic full lifetime accounting of C_{bio} as compared with carbon neutrality, particularly in the context of the soil compartment, previously not adequately assessed. Modelling C inputs to the soil from above- and belowground energy crop residues, as well exogenous matter and the dynamic gradual releases to the atmosphere, demonstrated temporary sequestration of C in the soil, gradually delaying the release. All residual crop fractions, when incorporated in the soil represent carbon releases to the atmosphere distributed over several years.

Combining the dynamic of SOC and associated land uses with prospective bioenergy scenarios is a novel approach. Without the modelling of SOC, temporary mitigation effects from agricultural annual and perennial energy crops are ignored. Perennial species, however, demonstrated higher mitigation potentials due to the C_{bio} stock in the rhizomes remaining in the production system during the entire rotation length. The SOC dynamic has proven sensitive to temperature and residue removal rates.

The case of the C_{bio} dynamic of perennial oil palm, showed a “loop-closing” system between the plantation site and mill unit in terms of reintegration of the C_{bio} from mill co-production in the soil. Moreover, variations in the model parameters have shown the dependency of the results on the FFB yields, tree planting density and rotation lengths.

Chapter 6:
Discussion: elements of
dynamic carbon cycle
modelling

6 Discussion: elements of dynamic carbon cycle modelling

6.1 Chapter context

Without the consideration of time, positive and negative contributions of C_{bio} and SOC emissions to the atmosphere add up to zero. Dynamic carbon modelling approaches related with forestry (Chapter 4) and agriculture (Chapter 5) demonstrated that annual biogenic C flows may not be carbon neutral. Moreover, it has been shown that time-dependent accounting of both biogenic and fossil sources delivers closer approximations of the actual climate change impacts per functional unit of a system.

This Chapter further discusses the main time-related elements and modelling approaches resulting from this work and the case studies conducted, summarised in Fig. 6-1, intended to support the framework proposed in Chapter 3. Therefore, a synthesis of the main findings is provided (section 6.2), followed by a short discussion on the main implementation challenges and sources of uncertainty in the results (section 6.3), and finally underlining why other methods were not considered in this work (section 6.4).

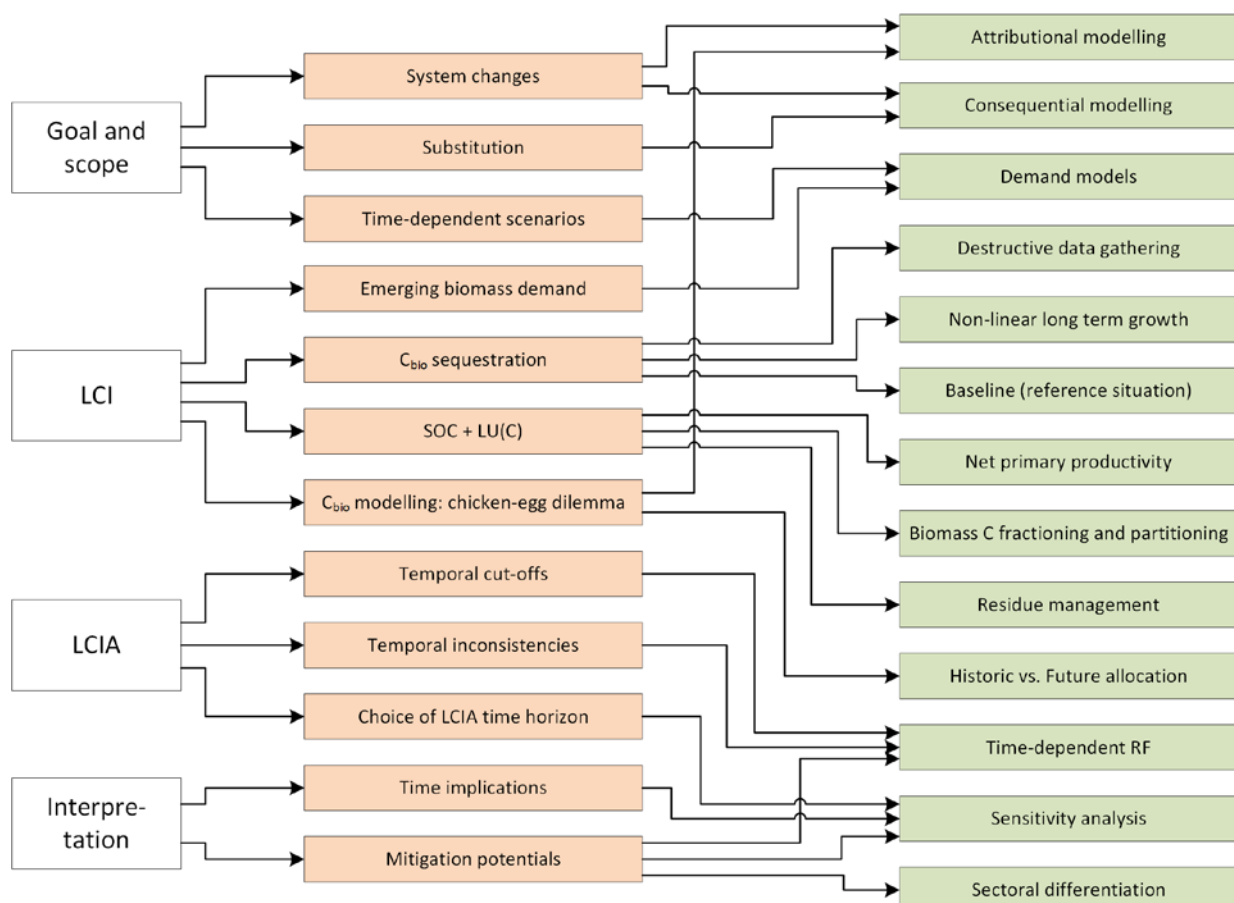

Fig. 6-1. Selected time-dynamic elements addressed (boxes third row) in this dissertation according to the identified issues (boxes middle row) along the life cycle phases (boxes first row)

6.2 Synthesis of the main findings

6.2.1 Dynamic upstream carbon modelling

Gaps have been identified regarding upstream modelling, concerning biomass growth, sequestration and SOC dynamics. The main elements are briefly described below.

Sequestration dynamic

Modelling time-dependent C_{bio} sequestration flows allows accounting for potential mitigation benefits, represented as negative flows. The removal of CO_2 from the atmosphere decreases the GHG concentration, inducing negative forcing effects. Throughout the methods and case studies in this work, it has been recognised that modelling dynamic sequestration is **biomass/type of plant species dependent**.

The main sequestration modelling criterion is the time required for a biomass to (re)grow. The established **point of divergence** is 1 year, splitting static (growth < 1 year) from dynamic (growth > 1 year) modelling requirements. The 1-year divergence separates short- from mid- to long-term C_{bio} sequestration, and is adapted to the time step of the radiative forcing metric at global scale, referring to well-mixed forcing agents with atmospheric lifetimes longer than 1 year (section 2.2.1).

Specifications on modelling requirements per biomass type are detailed, as follows:

- Annual species (growth cycle < 1 year) do not require modelling dynamic C_{bio} sequestration. The annual accumulation of C_{bio} in the biomass can be estimated, for instance, by means of the net primary productivity (NPP) indicator. It allows partitioning C_{bio} among the different plant fractions for modelling subsequent C_{bio} releases in other life cycle phases associated with the exported/harvested dedicated and residual biomass fraction (e.g. for bioenergy combustion), and the remaining residual biomass incorporated in the soil (SOC dynamic).
- Perennial species/short rotation coppice (growth cycle > 1 year) require modelling time-dependent C_{bio} sequestrations. Perennial grasses resemble annual species, in terms of the aboveground compartment harvested annually as a crop product. However, the belowground part involves biomass growth and C_{bio} sequestration dynamic of rhizomes during the rotation length, representing a carbon stock, in contrast with annual crops. Perennial trees or short rotation coppice (e.g. oil palm), on the other hand, have sequestration dynamics associated to both above- and belowground compartments.
- Forest tree species (growth > 1 year) require modelling time-dependent C_{bio} sequestration. Tree growth to maturity requires up to several decades, further postponing radiative forcing, thus featuring long-term sequestration potentials compared with any other biomass types.

Rotation lengths and mitigation potentials

The two forestry-related bioenergy case studies in Paper 1 (4.2) and Paper 2 (4.3) considered a rotation length up to 200 years, representing the longest growth curve tabulated in historic yield tables of the French forest wood supply chain. A sensitivity analysis in Paper 1 (4.2), however, suggests that the mitigation effect from long-term C_{bio} sequestration depends considerably on the modelled rotation length. The C-complete results were **sensitive to shortening the rotation length**: the shorter the modelled rotation length, the lower the carbon benefit from postponement of radiative forcing.

Soil organic carbon dynamic

Agricultural crops, particularly annual species, are considered C-neutral in the context of temporal dynamic, due to their short-term growth time, yet excluding temporal emission profiles linked with the SOC dynamic.

C inputs to the soil derive from above- and belowground plant fractions considered as dead biomass (crop residues and dead roots), and eventually also from inputs of exogenous organic matter (organic fertilisers). It was identified that the soil carbon sequestration effect is given due to the C added to the soil at a given year, followed by mineralisation and C releases. Thus, the release back to the atmosphere is not instantaneous, but the net return is gradually delayed over several years, with high intensity of releases (e.g. pulse emissions) in the first year and decreasing releases over time.

Paper 3 (5.2) demonstrated that the proportions of added C to the soil vary across different agricultural biomass types, and depend on residue management practices (removal rates) in place, including the partial displacement of mineral fertilisers by organic ones.

The outcomes of Paper 3 demonstrated that the C-complete balance with SOC flows is sensitive to i) changes in the decomposition rate constant and ii) variations in the aboveground removal rates. SOC benefits decrease considerably with temperature increase (e.g. due to climate change), because the decay rate rises with temperature and thus C releases to the atmosphere occur over a shorter period. Moreover, increased residue removal rates considerably reduce C inputs to the soil and thus also reduce the mitigation effect from SOC.

Moreover, a close causal relationship between **land occupation and residue management** was recognised. The sensitivity analysis of the case study in Paper 3 (5.2) demonstrated that the higher the residue removal rate, the higher the LU demand for crop production, and vice versa.

Upstream modelling of both C_{bio} sequestration and soil carbon

Modelling both C_{bio} sequestration and SOC dynamics provides a more accurate representation of biogenic-sourced flows and their mitigation effects. It has been partially demonstrated in the forestry-

related case studies with tree growth and simple decay functions Paper 1 (4.2) and Paper 2 (4.3). The modelling approach was improved by means of the dynamic SOC model assessing any biomass type in Paper 3 (5.2), capturing all positive upstream releases to the atmosphere.

From these findings, it can be stated that modelling growth and C_{bio} sequestration is **biomass type dependent**, and therefore not required in all cases. However, the SOC dynamic should be accounted for all biomass types, if above- and belowground residues are left on the field to decay, and the related upstream releases are not instantaneous (e.g. burning sugarcane residues at field).

Biogenic reference system – “no use”

A reference system/scenario, against which biomass supply chains can be compared, is required. For the forest-sourced bioenergy case study the reference system was defined by an alternative EOL pathway resembling a situation/scenario without human intervention (i.e. natural processes), including forest management (e.g. rotation lengths and thinning periods) but excluding bioenergy combustion.

The reference to residual wood demand for bioenergy thus represents the same amount of wood left behind on the forest floor after logging operations with a “no use” pathway, which does subsequently undergo degradation/decay processes. From this point of view, the same applies to agricultural systems, as demonstrated with the SOC modelling. All crop fractions not exported from the field for food, feed, bioenergy or biomaterials, are left behind, undergoing mineralisation. For instance, current developments in advanced biofuels increase the demand of lignocellulosic residues (e.g. straw), which would eventually have “no use” other than contributing to SOC and nutrient cycling.

6.2.2 Coupling carbon modelling with demand models

Paper 1 (4.2), Paper 2 (4.3), and Paper 3 (5.2) feature a demand model as the source of inventories, representing biomass use scenarios for bioenergy. The simulations demonstrated that the multi-annual energy program formulated in the energy transition policy, with additional constraints in the transport sector, meets the GHG mitigation targets due to shifting energy-pathways and overall reductions in energy demand.

The mitigation constraints lead to increased demand for advanced biofuels (as compared to the BAU policy scenario), which in consequence mobilise the biomass supply towards dedicated or residual lignocellulosic biomass. For the transport sub-sector this type of biomass supply represents a new commodity pathways (e.g. woody residues, perennial grasses), linked with non-food crop-based biomass resources and new biofuel markets (involving synthetic biofuels). Advanced biofuels are thus expected to increase in the final energy share in the years to come.

The GHG inventories of the PEM TIMES MIRET (the demand model) are C-neutral, estimating fossil-sourced emissions from the JRC well-to-wheel approach for blended biofuels, however

excluding C_{bio} sequestration and release flows. The coupling of PEM with C_{bio} and SOC models allows assessing the missing dynamic C_{bio} balance from the biomass commodity demand and thus developing **C-complete GHG inventories**. From the results, it derives that additional mitigation effects in bioenergy systems are linked with further postponing of radiative forcing due to historic C_{bio} sequestration and C inputs to the soil.

The framework proposed in Chapter 3 does not exclude using other demand models or combining C_{bio} models with LCA studies (e.g. as illustrated in Manuscript 4 in section 5.3), as the dynamic C_{bio} factors are modelled in way that they can be coupled with any flow of materials consumed in the studied system (i.e. physical flow) or elementary (e.g. CO_2) at any given year.

General advantages of the coupling of C models with PEM are, among others:

- Retrieval of dynamic inventories (i.e. annualised technical flows), analysing demand-supply pathways from the feedstock extraction to the finale energy services within one market/sector.
- Consideration of a detailed techno-economic database of key economic variables, such as demand, supply and market equilibrium and changes in response to external (e.g. policy induced) constraints/scenarios. Insights into system behaviour of prospective energy demand and emerging process pathways – an essential consideration of emerging market penetration and the future energy transition, informing policy decision making (Subramanian et al., 2018).
- Combining energy and land use/occupation scenarios from biomass commodity supply as bioenergy substrates. Paper 3 (5.2) revealed that the overall land occupation in the new policy scenarios decreases considerably, as the proportion of the derivative commodities (starch, sugar, oil) have a higher equivalent unit of area demand than the residual and dedicated lignocellulosic commodities.

General limitations associated with PEM include:

- Prospective simulations are determined by a start year (here the year 2007) to a specific end-year (here up to the year 2050), representing larger differences in the first years until achieving a new equilibrium and a drastic cut-off in the inventories with no further biomass mobilisation. To overcome this limitation, the coupling was performed some years after the start year of the simulation (here the year 2019), excluding the previous simulation years. Higher challenges are associated with the end-year of the simulation TH. One option is to assume a constant state afterward, to avoid the unrealistic cut-off.
- The model inner working environment is not detailed and data is not publicly available, thus lacking transparency and accessibility, introducing uncertainty, particular with increasing complexity (Lopion et al., 2018; Morrison, 2018; Pfenninger et al., 2014; Trutnevyte, 2016). The model outputs analysed in this work required data pre-treatment and recalculation of final

energy consumption and GHG emissions releases due to unclear/intransparent linkage between the individual process pathways and data, associated with the lack of documentation.

- Exclusion of economic cross-sectoral interactions (e.g. effect of change on other markets, as only one market is analysed) with limited assumptions (Loulou et al., 2016). For instance, the consequences from substitution of fossil fuels by biofuels on other life cycles or sectors are not analysed. Consequential LCA approaches, broadening the system boundaries, may involve direct and indirect effects on other life cycles (e.g. product displacement, land use change), and further analyse the effects, for instance, of a demand change in other sectors or economies, if the demand for a specific biomass (e.g. energy crops, dedicated wood) increases significantly (i.e. non-marginal changes). Thus PEM model does not necessarily fulfil the objectives of consequential LCI, yet it analyses socio-economic mechanisms conducting towards consequential objectives (Guinée et al., 2018; Marvuglia et al., 2013; Vázquez-Rowe et al., 2013).

6.3 General implementation challenges and sources of uncertainty

6.3.1 Modelling challenges

The main implementation challenges faced in this work are shortlisted for both the inventory and the impact assessment, as follows:

- The chicken-egg dilemma on C_{bio} sequestration – an allocation issue: Long-term sequestration profiles have a considerable impact on the C-neutral results, depending on whether the timing of the sequestration is accounted for under a historic (carbon benefit) or future (carbon debt) time perspective. This modelling decision was identified as an allocation challenge for attributional LCA, referring to the causal physical relationship of attributing C_{bio} to a harvest activity, thoroughly discussed in Paper 2 (4.3). Recommendations were provided based on a set of decision rules and established definitions to justify choices. The main criteria are rooted in the discrepancy between the previous state and sphere of forests (managed or un-managed), and whether the biomass is/was allowed to re-grow after the harvest activity. The consequences of management changes in the harvest itself may occur after the harvest (future), relating to other than the allocation issue (e.g. consequential modelling approach).
- Static versus dynamic relative impacts: As already highlighted in the proposed framework (Chapter 3) and underlined in Paper 2 (4.3), a comparison between static and dynamic relative radiative forcing results [$\text{kg CO}_2\text{-eq}\cdot\text{kg}^{-1}$] should be implemented with caution, as the two metrics have different impact representations. The main inconsistency lies on the different time horizons generated by the different emission years. The framework example showed how to conduct a consistent comparison under consideration of the same temporal boundary. Comparing relative results becomes particularly challenging for studies with different

temporal boundaries, as demonstrated with the two opposed (historic and future) modelling time perspectives in Paper 2 (4.3). The same applies to LCA studies with different inventory years. In contrast to the relative metric, the cumulative RF metric [$\text{W}\cdot\text{yr}\cdot\text{m}^{-2}$] allows comparisons among different scenario with different temporal boundaries or inventory years.

- Unavoidable choice of a TH for comparison purposes: Throughout the case studies, the commonly used 100-year TH was retained. This choice remains subjective, based on the IPCC and UNFCCC choice. As discussed previously, the dynamic LCA approach likewise faces the challenge of choosing an LCIA TH for comparison purposes. Yet, the LCIA TH in the dynamic approach expresses the forcing effect between the year of the GHG release and a chosen future reference year. It is thus more consistent with the actual atmospheric contribution of GHG emissions concerning the temporal boundaries and chosen TH. It further allows analysing the evolution of GHG contribution and the respective radiative forcing effect over very long-term periods. For C_{bio} balances, reference years far into the future, featuring several centuries are not recommended, as the C_{bio} flows converge to an equilibrium reaching steady-state representations (i.e. carbon neutral). Thus, setting a LCIA TH, allows capturing temporary C_{bio} sequestration and analysing the timeframes with higher negative forcing effects or their time-sensitive effects on the results, which is not possible with the static approach.
- Temporal cut-offs: Even though dynamic inventories of both biogenic and fossil sources of a study may cover all potential emissions described through time, temporal cut-offs depend on the chosen future reference year of the dynamic impact assessment, i.e. to the setting of the LCIA TH. Therefore, the LCIA TH may be set over an additional number of years into the future accounting from the last emission release. Throughout all case studies, it was identified that all long-term inventoried C_{bio} release flows exclusively related with decay have a long persistency in the technosphere until approaching net zero.

6.3.2 Sources of uncertainty and limitations

Uncertainty from input data and data availability

Modelling dynamic C_{bio} flows has been challenging due to additional data requirements per vegetation species, often not readily available. Due to lacking forest yield data for some forest tree species, data from other geographical locations in Europe were used as a proxy, at least also corresponding to temperate climatic conditions.

Modelling non-linear biomass growth (forest tree, perennial grasses or oil palm growth) was based on secondary data and allometric relations with parametrised values, which may increase the uncertainty in the results. The growth of miscanthus and switchgrass rhizomes was approximated with linear correlations between age and biomass growth, as justified by Rehbein et al. (2015) and a meta-analysis

by Agostini et al. (2015); however it may represent a bias in the time-dependent C_{bio} sequestration results.

Moreover, the CH_4 ratio from biomass sources, for instance from above- and belowground anaerobic conditions of biomass decay, peat land, POME, etc., was not easily available due to the scarcity of studies on this source of GHG emission.

Uncertainty from spatial dynamic – Site-generic, site-dependent and site-specific data

This dissertation focused on the temporal dynamic of biotic resources to reduce the uncertainties linked with linear models and C-neutrality. Yet, biomass yield and land management practices can vary, depending on spatial dynamic, such as pedoclimatic conditions. LCA studies often use site-generic averaged data (e.g. from national statistics) or proxy approximations to represent potential environmental impacts, evoking uncertainty and eventually introducing bias in the results.

The C_{bio} and SOC model parameters of this work used site-dependent data, revealing **a close relationship between the temporal and spatial dimensions for modelling biomass systems**. Local conditions, i.e. site-specific variables, do play an essential role in modelling forestry and agricultural systems (i.e. products with a function per unit of area). However, the level of detail in site-specific surveys for estimating C_{bio} dynamics was beyond the scope of this work.

The forestry modelling data (Appendix D: Data paper on forest models) relied on empirical data from long-term field studies, tabulated in yield tables and national forest inventories, to predict the mean tree growth dynamic and carbon fixation. The forest model itself proved to be robust enough regarding growth parameters (see sensitivity analysis in Paper 1, section 4.2) and flexible due to its applicability to any technical flows or sectors. However, the model did not consider unexpected events and losses (e.g. disease, wildfire, drought, mortality). Statistical estimates on tree mortality in France were indirectly considered in technical outputs from the partial equilibrium model, yet at larger spatial scales (i.e. averaged to the national level). Moreover, Pretzsch et al. (2014) demonstrated substantial changes from growth and yield rate accelerations of standing stocks within Central Europe due to climate change, which depends on the geographical locale.

The SOC modelling data in this work (section 5.2) relied on site-dependent, but not site-generic data, because the parameters of pedoclimatic conditions, involving soil temperature and texture were based on averaged values for continental France. Moreover, residue management practices were estimated from national statistics. However, SOC modelling reveals site-specific complex processes and sub-processes affecting soil quality and quantity (e.g. erosion, texture, humidity, C/N relation, living organisms, and nutrient leaching). Paper 3 (5.2) demonstrated the sensitivity of the decomposition rate constant (k) to changes in temperature. Process-oriented soil models commonly use short-termed time

steps (hour or day) to capture the temporal variability of parameters. Yet, time steps lower than 1 year are not relevant for impact assessments at global scale (e.g. climate change).

More complex or multi-compartment models would further improve site-specific simulation approaches. LCA practitioners can refine the C_{bio} model parameterisation if needed in their particular cases.

Uncertainty from system boundary definition

Defining the system boundary can represent a source of uncertainty, as it will determine whether all upstream and downstream C_{bio} and SOC flows are taken into account. The framework example in section 3.4 showed a full lifetime accounting approach of a biomaterial (lumber and coproduction) from cradle-to-grave, modelling upstream sequestration flows, emission delays during the use phase as well as the release flows and potential permanent C_{bio} stock in the EOL phase.

Moreover, the mitigation effect from C-complete results differed considerably when the dynamic C_{bio} balance accounts for all transport fuels (i.e. fossil and biogenic-sourced) or for a specific product system (e.g. bioethanol). In Paper 1 (4.2) the wood-to-bioethanol pathway from the PEM simulations resulted in negative climate effects over 400% larger than C-neutral results (over a LCIA TH of 100 years). On the other hand, when accounting for all biomass-to-fuel pathways, the mitigation effect from wood-related C_{bio} sequestration resulted in about 3%. The considerable difference for bioethanol was explained by the relative low contribution of the fossil-sourced GHG emissions (5.4%) to the net emissions of bioethanol and the modelled historic long sequestration period.

Nonetheless, increasing the number of sub-processes thus leads to a natural increase in process, data and modelling uncertainty. The goal and scope of the study will define whether a high level of detail in the modelling is required, depending on the system boundary set.

Modelling limitations concerning other methods

An essential limitation concerns the goal and scope definition of this research taking into account the temporal consideration of C_{bio} flows and the time-sensitive climate change effects under the dynamic LCA method and not further exploring other existing biogenic-sourced methods involving climate forcers (e.g. mean global surface temperature change, surface albedo effects) and their temporal considerations/interpretation in dynamic modelling. Details on such issue are provided in directions for further research in section 7.2.1.

6.4 Identified limitations from the GWP_{Bio} due to dynamic carbon modelling

The proposed framework (Chapter 3) is based on the dynamic LCA approach for temporal consideration of emission profiles developed by Levasseur et al. (2010a, b). It is the only method used

in this work because it features both the timing of an emission occurrence by means of temporal differentiated emission profiles (i.e. annually differentiated GHG emission inventories) and time-dependent CFs with flexible time horizons (TH). It thus enables assessing dynamic C_{bio} inventories in a consistent manner with the respective to the temporal boundaries of the studied systems.

The alternative GWP_{Bio} metric, developed by Cherubini et al. (2011a), challenges the assumption that carbon-neutral is equivalent to climate-neutrality, as it demonstrates that CO_2 releases from biogenic sources have an impact on the overall atmospheric concentration (Guest et al., 2012). The approach feature dynamic modelling of aboveground biomass and the impact factors directly applicable in LCA bioenergy studies, yet the method faces the following dynamic modelling limitations:

- GWP_{Bio} factors are applicable to bioenergy systems only, disregarding other C_{bio} pathways or EOL options (e.g. decay), including SOC dynamic or delays (e.g. extended service life of biomaterials).
- The biogenic CO_2 emissions are neutralised when the biomass is regrown, and when no regrowth occurs the emissions equal anthropogenic fossil ones (Brandão and Levasseur, 2010; Guest et al., 2012).
- The modelling approach for biomass growth uses a dynamic approximation by fitting a normal curve, which is not an accurate approximation for dynamic C_{bio} sequestration of biotic resources, as explained in section 2.6.1. The same normal curve is applied to any biomass type differentiated by a rotation length to represent the biomass growth curve, limited to 100 years, and thus ignoring longer sequestration periods. As demonstrated with the forest and perennial species in this work, dynamic growth is specific to each species and the rotation length may go beyond 100 years.
- The general biomass-to-bioenergy model pictures future time perspectives only, i.e. harvest activities are modelled before biomass growth, consequently implying a carbon debt. This modelling approach is applied to all biomass types, from sustainably managed systems. Timing possibilities of the harvest activates after the growth are not further discussed. This missing consideration has been criticised by Cornillier and Benoist (2015) and Benoist and Bessou (2018). Furthermore, Paper 2 (4.3) discussed the option of modelling historic time perspectives for managed forestry systems.
- The LCIA THs are fixed to 20, 100 and 500 years, like for the static GWP metric approach, featuring the same inconsistency between the different emission years and the impact representation. The method thus does not fully address dynamic LCA.
- It does not provide the option of comparing the bioenergy system with a respective reference system, such as highlighted in Paper 2 (4.3) with the “no use” scenarios, denoting forest wood

residues left on the forest floor to decay. This has further implications on the consideration of other non-CO₂ emissions.

6.5 Chapter conclusion

The modelling choices and exclusions made in this work have been discussed and supported, thus paving the way for overall conclusions and offering directions for further research aiming at complementing the proposed modelling framework, and reducing its associated uncertainty.

Chapter 7:
Conclusions and directions for
further research

7 Conclusions and directions for further research

7.1 Overall conclusion

7.1.1 Conclusions on the proposed modelling framework

This dissertation aimed at answering two key questions: i) how to model time-sensitive climate change effects from disaggregated positive and negative biogenic-sourced carbon flows (i.e. quantify temporal carbon profiles) from managed forestry and agricultural systems, and ii) how to apply/operationalise such modelling approaches within the dynamic LCA framework to further contribute to the dynamic LCA methodology development for biomass systems and reconsider or re-evaluate carbon neutrality and climate mitigation approaches.

It was found that many existing methods often use top-down approaches to account for carbon stocks from global and regional biomes —an approach harmonised with the carbon stock change accounting methods for national GHG inventories—, which can subsequently be scaled down to a particular functional unit. This work, in contrast, used a bottom-up approach to quantify the C_{bio} flows associated with any technical flow (i.e. amount of biomass consumed to fulfil a function), as well as its coupling with outputs of any demand model, here tested with the TIMES-MIRET partial equilibrium model. Such model integration enables, for instance, the prospective evaluation of emerging biofuel demand under consideration of the economic equilibrium theory. Both approaches lead to the assessment of a functional unit within the LCA methodology, yet the proposed approach facilitates the dynamic modelling of these flows, directly applicable with the help of an operational tool.

The overall application of C_{bio} modelling within the dynamic LCA framework was elaborated in Chapter 3. The proposed framework allows implementing a full lifetime carbon accounting approach, as the sequestered and/or stored carbon is (re-)emitted back to the atmosphere, either instantaneously or gradually, thus taking into account all C_{bio} flows throughout the life cycle. Accounting carbon from biotic resources requires inventorying both negative and positive emissions, to avoid misleading decision support. By describing all carbon flows throughout the life cycle of a product or service, it will be transparent when carbon is (re-)emitted and (re-) sequestered along the timeline, as well as how much C_{bio} and how long it is stored in the technosphere contributing eventually to climate change mitigation.

As highlighted in the proposed framework, the temporal profiles of disaggregated C-complete flows per species and functional unit rely on three main dynamic elements by means of which the temporal variability is described: i) biomass growth and SOC sequestration modelling of forest tree and perennial species, ii) temporary carbon stock accounting during transformation and use phase of long-lived bioproducts, and iii) EOL modelling. Temporary carbon storage during the transformation and

use phase is determined by the type of bioproduct itself, without requiring any additional modelling step. It defines whether the carbon releases to the atmosphere are instantaneous (e.g. bioenergy systems) or further delayed/postponed into the future (e.g. embedded carbon in long-lived biomaterials in buildings).

The dynamic modelling requirements are thus particularly associated with upstream and downstream phases/systems specific to each type of biomass species (e.g. forest tree, annual crops, perennial grasses, etc.), mainly with biomass production (upstream), involving several dynamic elements regarding: plant growth, yield assumptions, land use requirements and land use management or changes in land management (including residue removal rates), whose dynamics cannot be modelled in a generalised manner, but case-specific.

The forest-sourced biomass dynamic assessed in Chapter 4, is associated with variable long rotation lengths, with some species (i.e. forest trees) featuring growth cycles over one century. The dynamic growth and C_{bio} sequestration models in this dissertation are applied to harvested round wood and residues, under the simplified assumption that growth and sequestration curves are the same for all tree fractions (above- and belowground). The model can further be improved by modelling the growth and thus carbon sequestration dynamic individually for each tree fraction.

Describing the time dimension in the GHG inventory of forest biomass is necessary to overcome the (inherently erroneous) carbon neutrality assumption, given large time gap between the C_{bio} sequestration and the release. Statistical computation fitting parameters with nonlinear regression and allometric relations to predict the temporal dynamic of mean forest tree growth/development (i.e. dependency of growth in age-and size) and the accumulation of C_{bio} in the biomass is an increasingly used and accepted approach in forest ecology and growth analysis. The statistical progress and maturity in growth analysis better captures the temporal dynamic than, for instance, normal, (log)linear or polynomial models. The positive C_{bio} return from wood decay likewise requires a long period, particularly for the belowground root fraction.

As suggested in this dissertation, energy crops or annual species do not require growth modelling when they are harvested within a one year period. The C_{bio} embedded in the biomass does not have a particular time dynamic. However, including SOC flows in GHG inventories is an essential dynamic component, because it takes into account the gradual release flows from the biomass fractions (referring to above- and belowground residual plant parts) that are usually ignored. The particular case of perennial oil palm showed that almost all the biomass contributes to SOC, as nearly all plant fractions are systematically returned to the soil (see section 5.3).

An essential consideration in the context of SOC modelling of biogenic sources, are the increasing removal rates of wood residues for bioenergy, which reduce the C added to the soil, thus affecting the

SOC dynamic, representing a different EOL dynamic than in absence of bioenergy (i.e. instantaneous release with no delay due to combustion or incineration).

By modelling the C_{bio} release and EOL pathways, the net C_{bio} balance will reach a net zero value at some point in time, as long as there is no permanent storage involved in the studied system. While the sequestration reduces C in the atmosphere, each carbon release contributes to increases in the atmospheric concentration thus to radiative forcing. The atmosphere does not distinguish between fossil or biogenic sourced emissions. The forcing effects from releases may be worse when non- CO_2 GHG are emitted, such as CH_4 , typically associated with biomass decay, as demonstrated in the reference case with the no use/reference scenarios (i.e. in the absence of bioenergy pathways, see sections 4.2 and 4.3).

Concluding on the proposed modelling framework, in response to an essential question of whether it is worth the additional effort for dynamic C_{bio} modelling under the temporal consideration, depends highly on the goal and scope of the system under study and the inherent dynamic. In the context of LCA, aiming at representing the impacts of a functional unit of a system (i.e. product or service scales), it is recommended to account for dynamic C_{bio} flows for the following reasons: accounting for C_{bio} sequestration and SOC flows, reducing the uncertainty in climate change impact assessment of biomass use, and providing better decision-support. On the other hand, studies at landscape, national or even global levels, the goal and scope of the study is different, as the inventories are built on annual carbon stocks and changes (e.g. land use change due to deforestation). Consequently, dynamic C_{bio} modelling is less relevant because the sum of all carbon stocks of the same land use at larger scales tend to equilibrium, even though the systems are dynamic under temporal considerations (i.e. different age classes and harvesting periods).

7.1.2 Remarks on climate change and mitigation approaches

The question on whether biogenic-sourced products should be used to compensate for C fossil-sourced ones remains open. Derivatives from renewable feedstock have lower energy density and efficiency, which requires higher amounts of biomass to offset an energetically equivalent unit of C fossil. These biomass-based products are associated with specific land use requirements, which increase with increasing dedicated or residual feedstock demand. Current climate-energy policies promote an augmentation of the biomass share of lignocellulosic residual biomass, due to competing land use requirements for other demand (e.g. food).

However, each unit of C_{bio} emitted to the atmosphere contributes to radiative forcing and the re-sequestration in the biomass can take up to several decades for forest trees. The consideration of this time lag is crucial to draw conclusions on climate change mitigation efforts under short- or long-term time preferences. Even if a historic modelling perspective is justifiable for C_{bio} sequestration in an

attributional LCA context, and the biomass is allowed to regrow, emitting the sequestered or stored carbon in the biomass or biomaterials contributes to the GHG mass, which may be questioned, regarding the urgency of climate change mitigation (given eventually irreversible consequences such as permafrost melt and ice-sheet melting).

The consideration of the time dimension in the evaluation of biomass-based products in this dissertation highlights how dynamic modelling alters static results, particularly showing the importance of biomass with long rotation cycles, the sensitive SOC effects on land use requirements, and the consequences on the Earth climate system from increasing the removal rate of residual biomass. A technically-decided balance between dedicated and residual biomass, to feed the biofuel industry, should be the basis for decision-making (and EU policy) on that regard.

Climate mitigation should aim at keeping CO₂ off the atmospheric pool, which goes beyond product level evaluations in LCA. The question then arises on how to choose the best climate change mitigation alternative. The response would intuitively be the preservation of carbon stocks, i.e. not cutting down forest trees or other existing natural biotic resources, as any change affects the terrestrial carbon stocks. There is no doubt that biomass with long rotation lengths, such as forests, are beneficial for coping with the climate tipping points, as the carbon is retained in vegetation for longer periods. If trees achieve maturity, the growth curve shows an asymptotic development, slowing to stopping CO₂ fixation; however, the carbon will remain stored in the tree organs over decades.

Additional efforts, such as increasing terrestrial carbon stocks, particularly by forestry, may represent the most important mitigation alternative in combination with technological innovation (e.g. carbon capture and storage, efficiency gains). Offsetting mechanisms per unit of C_{bio} should consist of restoring/replanting that unit of emitted C_{bio} in addition to the unit of C_{bio} used to substitute or displace one unit of C fossil, for the sake of the urgent need for mitigation. It means that in the absence of bioenergy or biomaterials, additional CO₂ sequestration should be considered for C fossil compensation. Artificially doubling the C_{bio} accounting benefit to increase the demand for residual biomass, as currently incentivised in EU initiatives, is not an adequate option, as it may conflict with SOC and land use dynamic.

7.2 Directions for further research

Modelling recommendations have been made for solving the issue of dynamic C_{bio} modelling of biomass-based products, aiming at assessing the time-sensitive climate change effects. The purpose of the dissertation has been achieved by evaluating and proposing dynamic peer-reviewed models published in scientific journals, which contributed to further developing the dynamic LCA approach. All dynamic C_{bio} inventories used in this dissertation were built with a proprietary tool developed for IFPEN, implemented in Excel. However, the practical application requires further development of the

Excel file to make it accessible to LCA practitioners. The construction of a user-friendly tool to enable C_{bio} inventorying of biomass-based products would be relatively easy for a dedicated team, and such an endeavour is thus a key recommendation from this work.

Further, it is recommended to incorporating missing elements into the dynamic LCA framework to provide a “better” (i.e. more accurate and comprehensive) response to the question on whether increasing the production of biomass or residues for biofuels and/or biomaterials (including intermediate chemicals) contributes to reducing GHG emissions, and ultimately slowing down or halting climate change. Some of elements concerning specific topics/research directions are listed and detailed in the next sections.

7.2.1 Explore other impact methods for GHG and non-GHG climate forcers

The dissertation focused on the GWP metric and its dynamic interpretation by means of the time-dependent CFs (i.e. dynamic radiative forcing concept), but further considerations are required regarding the GTP metric, as applied by Shimako et al. (2016), and its dynamic interpretation as a function of time in terms of dynamic negative and positive carbon emissions. The GTP assesses the variations in global mean surface temperature for a specific chosen year, as an instantaneous metric; however, current factors by the IPCC are available for fixed THs. The dynamic LCA framework for the climate change impact category should include the dynamic GTP and an assessment tool for dynamic inventories, thus complementing the temporal consideration of well-mixed GHGs further down the cause-effect chain by means this second climate metric.

The primary orientation of this work was the modelling of dynamic carbon inventories and their time-sensitive climate change effects associated with the radiative forcing concept. The applied dynamic LCIA method with annual time steps refers to well-mixed GHG emissions only assessed via global climate models. The proposed framework did, however, not further explore the time dynamic implications of other non-GHG climate forcers, such as the near-term/short-lived climate forcers with inter-annual time steps (e.g. ozone, biogenic volatile organic compounds) and biogeophysical climate forcers associated with land use and land surface cover changes (e.g. surface albedo). Even though the dynamic modelling and temporal consideration of such climate forcers may not directly be involved with C flows, it is indirectly linked with biomass and land use. Therefore, further research is needed to develop dynamic models (eventually also involving the hydrological cycle affecting the climate system) and its implementation in dynamic LCA framework. As highlighted in the state of the art of this dissertation, some LCA studies for bioenergy systems have addressed this issue. The dynamic interpretation and operationalisation, however, needs to be investigated in the context of indirect effects from biomass and land use under consideration of the spatial dimension.

7.2.2 Combine spatio-temporal modelling approaches

Time and space dynamic are found to be essential variables when modelling biomass supply chains, which require better understanding in the development and improvement of models, applicable within the dynamic LCA framework. The land use/occupation factor involves site-dependent or site-specific data (e.g. described in yield tables) and model parameters (e.g. temperature, soil texture, etc.).

For instance, crop yield is area dependent [$\text{t}\cdot\text{ha}^{-1}$], which was considered constant every year in the C_{bio} sequestration and SOC modelling of prospective studies. However, yield or productivity of biomass may potentially vary over time, increasing due to improvements in land management practices, or declining due to increased droughts (e.g. climate change related) or unexpected events (e.g. diseases, wildfires, etc.), or even due to natural variability. The carbon benefit is thus directly affected by the biomass production/yield per unit of area.

For future studies, it is recommended to include the spatialised component of carbon modelling approaches, specifying the site-dependent or site-specific model parameters and data. Even though the proposed models can be refined for specific case studies, more research is needed to better understand how to simultaneously assess and implement the temporal and spatial dimensions of technical flows, to further improve the dynamic LCA approach (recent advances on the integration of the spatial differentiation in LCA are discussed in Patouillard et al. (2018)). It is an essential consideration for impact categories beyond the climate forcers (including the aforementioned near-term and biogeophysical climate forcers), such as biodiversity, water footprinting and ecotoxicity (e.g. Payen et al. 2018; Viveros Santos et al. 2018; Vrasdonk et al. 2019).

7.2.3 Develop integrated multi-criteria modelling approaches

From a wider perspective, the coupling of LCA with demand models can be further improved across temporal and spatial scales, for instance, by using flexible hybrid models of bottom-up and top-down economic-wide effects, involving indicators from Input-Output tables, System Dynamics, and Agent-Based models (as recently reviewed in Beaussier et al. (2019)).

Such modelling approaches could further be combined with consequential LCA. Consequential LCA studies have included socio-economic indicators by expanding the system boundaries of the study and relying on economic models (such as input-output tables and partial or general equilibrium models) to model, for instance, the effects from emerging markets, product substitution and externalities.

With the growing political interest towards the development of bio-economies, taking into account the consequences from (i)LUC of biomass supply chains remains an important research direction in LCA. Direct and indirect LUC (iLUC), often related with the expansion of biomass production for bioenergy, may also be further developed under temporal considerations of associated time-sensitive

climate change consequences. For instance, it can be questioned how far into the past and/or into the present are LUC drivers and effects traceable or predictable. Concerning biogenic flows, LUC might be linked with negative emissions (e.g. afforestation of marginal or degraded lands), or, on the contrary, severe damaging effects (e.g. deforestation of tropical rainforest) over time. Modelling iLUC has been far more challenging: for over a decade this aspect has been discussed by the LCA community, however, it lacks scientific consensus (e.g. Finkbeiner 2013; Muñoz et al. 2015; Schmidt et al. 2015). In terms of mass flows and stocks (carbon input and output), a similar bottom-up approach, as proposed in this work, could be used for (i)LUC, to assess the carbon dynamic from a biomass demand and the time required to restore a pre-existing carbon stock compared to the time of relaxation towards natural regeneration.

The purpose of such a multi-criteria model would represent the effects or consequences on the environment in response to political constraints, with feedback loops. The results remain sensitive to a number of indicators, assumptions and sub-processes made due to the rising modelling complexity, leading to increasing uncertainty in the results. However from an LCA perspective it would provide a holistic prospective evaluation of the environmental state by a given action, and on how policies can better respond to it before defining targets and actions.

7.2.4 Support LCA guideline through dynamic approaches and results

Dynamic LCA may be regarded as an appropriate tool for defining guidelines for conventional/static LCA. Given that dynamic modelling increases complexity and working-time (e.g. due to more data requirements, identifying and testing adequate models, etc.), which may not be available or feasible for many LCA practitioners (e.g. due to higher time and resource investments), dynamic LCA can at least contribute to improve LCA guidelines, by pinpointing at key dynamic elements contributing to impacts, which may not be obvious under a static approach.

In the context of C_{bio} , as highlighted in this dissertation, it is essential to account for the temporal variability of both negative and positive flows; meaning that a simple carbon neutral assumption is not appropriate for the following reasons: a) the time lag between release and biomass regrow, b) the delay and (permanent) storage of carbon, and c) the land use requirements and SOC contributions. For some systems under study a temporal consideration may not be as relevant as for others. The results from the dynamic assessment would thus feed the development of guidelines for biomass-systems with more holistic understanding and provide the necessary information when temporal consideration is pertinent.

7.2.5 Conduct multi-indicator dynamic soil (carbon) modelling

The SOC model in Chapter 5 represents an oversimplification of the actual dynamic mechanisms in the soil. However, it complies with the objective of modelling the added C to the soil from biogenic

sources and its gradual return/evolution to the atmosphere as a function of time; applicable to the LCA framework. Yet, soil and soil carbon science reveal a higher level of complexity in upstream modelling, involving various parameters and processes across different soil layers, affecting soil quality and quantity (e.g. erosion, texture, humidity, C/N ratio, living organisms, soil aggregates and nutrients leaching), some of which are still not fully understood. Therefore, substantial research is needed to further explore the dynamics of soil to define the relevant indicators to conduct appropriate impact evaluations of SOC flows. Ongoing research in soil quality indicators, for instance, has failed to date to produce a comprehensive and consensual soil quality indicators or indicator set.

7.2.6 Integrate land-use modelling in policy scenarios

The dynamic SOC model proposed in this dissertation partially responds to the current EU climate change mitigation initiatives such as the “4 per 1000”, aiming at increasing carbon stocks in agriculture and forestry soils. The perception of soil carbon and land use needs to be reconsidered and further understood, because the more residues are removed per unit of area, for instance, for lignocellulosic-based bioenergy, the higher the area requirements for C_{bio} sequestration and added C to the soil, as concluded from the SOC modelling simulations (section 5.2). A minimum requirement of SOC is necessary for soil functioning and yield achievements. That added C is provided from the residual fractions of the crops and/or exogenous matter (i.e. organic fertilisers) proportional to the biomass exports from the field.

It is thus recommended to include the proposed dynamic modelling approach in land use modelling approaches, and not only in the context of land use change (which has been far more widely researched). The coupling of carbon models with (prospective) bioenergy scenarios supports a more holistic understanding of SOC and land use implications from future biomass use. The scenarios would take into account different coefficients and variables concerning changes in land management practices, involving not only residue removal rates, but also the use of organic fertilisers, divers farming activities influencing soil properties and function, etc. The land use bound scenarios can be further contracted with conventional practices for comparison reasons.

7.2.7 Other considerations

Other considerations include indirect effects (i.e. externalities) induced by biomass expansion, forgone sequestration in the absence of harvest activity of forest trees at maturity, allocation of secondary biomass-sourced products, climate effects from increasing demand of long-lived products, and the reintegration of secondary or tertiary biomass-sourced materials (loop-closing effects).

Moreover, complementing dynamic approaches with uncertainty analysis would provide more robust assessment and better decision-support. Dynamic modelling particularly integrated with other models (e.g. partial-equilibrium) increase the uncertainty due to a higher number of parameters used

Chapter 7: Conclusions and directions for further research

(background concentration, mean temperature, carbon content, growth rate, etc.) and assumptions made (e.g. time preferences, yields, demand, etc.). The results are thus sensitive with increasing model complexity. The performed case studies in this dissertation included sensitivity analysis concerning some model parameters and assumptions. However, the robustness of the proposed models requires analysing the results with a larger database to identify the data margins and gaps.

References

- Aalde, H., Gonzalez, P., Gytarsky, M., Krug, T., Kurz, W.A., Ogle, S., Raison, J., Schoene, D., Ravindranath, N.H., Elhassan, N.G., Heath, L.S., Higuchi, N., Kainja, S., Matsumoto, M., Sanchez, M.J., Somogyi, Z., 2006. Forest Land. 2006 IPCC Guidel. Natl. Greenh. Gas Invent. 4, 4.1-4.83. <https://doi.org/10.1016/j.phrs.2011.03.002>
- ADEME, 2011. BP X 30-323: Principes généraux pour l’affichage environnemental des produits de grande consommation - Partie 0 : principes généraux et cadre méthodologique -. Paris.
- Adhikari, K., Hartemink, A.E., 2016. Linking soils to ecosystem services - A global review. *Geoderma* 262, 101–111. <https://doi.org/10.1016/j.geoderma.2015.08.009>
- Adler, P.R., Del Grosso, S.J., Parton, W.J., 2007. Life-Cycle Assessment of Net Greenhouse-Gas Flux for Bioenergy Cropping Systems. *Ecol. Appl.* 17, 675–691. <https://doi.org/10.1890/05-2018>
- Agostini, A., Giuntoli, J., Boulamanti, A., 2014. Carbon accounting of forest bioenergy. Conclusions and recommendations from a critical literature review. EC JRC Scientific policy reports. Rep EUR 25354 1–87. <https://doi.org/10.2788/29442>
- Agostini, F., Gregory, A.S., Richter, G.M., 2015. Carbon Sequestration by Perennial Energy Crops : Is the Jury Still Out ? 1057–1080. <https://doi.org/10.1007/s12155-014-9571-0>
- Albers, A., Collet, P., Lorne, D., Benoist, A., Hélias, A., 2019. Coupling partial-equilibrium and dynamic biogenic carbon models to assess future transport scenarios in France. *Appl. Energy* 239, 316–330. <https://doi.org/10.1016/j.apenergy.2019.01.186>
- Allen, M.R., Fuglestvedt, J.S., Shine, K.P., Reisinger, A., Pierrehumbert, R.T., Forster, P.M., 2016. New use of global warming potentials to compare cumulative and short-lived climate pollutants. *Nat. Clim. Chang.* 6, 1–5. <https://doi.org/10.1038/nclimate2998>
- Andriulo, A., Mary, B., Guerif, J., Andriulo, A., Mary, B., Guerif, J., Andriulo, A., 1999. Modelling soil carbon dynamics with various cropping sequences on the rolling pampas. *Agron. EDP Sci.* 19, 365–377.
- Archer, D., Kheshgi, H., Maier-Reimer, E., 1997. Multiple timescales for neutralization of fossil fuel CO₂. *Geophys. Res. Lett.* 24, 405–408. <https://doi.org/10.1029/97GL00168>
- Archontoulis, S. V., Miguez, F.E., 2015. Nonlinear regression models and applications in agricultural research. *Agron. J.* 107, 786–798. <https://doi.org/10.2134/agronj2012.0506>
- Ardente, F., Cellura, M., 2012. Economic Allocation in Life Cycle Assessment: The State of the Art and Discussion of Examples. *J. Ind. Ecol.* 16, 387–398. <https://doi.org/10.1111/j.1530-9290.2011.00434.x>
- Avadí, A., Corson, M.S., van der Werf, H.M.G., 2017. Modelling environmental effects of selected agricultural management strategies with regional statistically based screening LCA. *Int. J. Life Cycle Assess.* <https://doi.org/10.1007/s11367-017-1300-4>
- Baede, A.P.M., Ahlonsou, E., Ding, Y., Schimel, D.S., 2001. Chapter 1 The climate system: An overview, in: Trenberth, K.E., Houghton, J.T., Meira Filho, L.G., Houghton, J.T., Meira Filho, L.G., Callander, B.A., Harris, N., Kattenberg, A., Maskell, K. (Eds.), IPCC Third Assessment Report: Climate Change, Working Group I: The Scientific Basis. IPCC, pp. 87–98.
- Baitz, M., Albrecht, S., Brauner, E., Broadbent, C., Castellan, G., Conrath, P., Fava, J., Finkbeiner, M., Fischer, M., Fullana I Palmer, P., Krinke, S., Leroy, C., Loebel, O., McKeown, P.,

References

- Mersiowsky, I., Möginger, B., Pfaadt, M., Rebitzer, G., Rother, E., Ruhland, K., Schanssema, A., Tikana, L., 2013. LCA's theory and practice: Like ebony and ivory living in perfect harmony? *Int. J. Life Cycle Assess.* 18, 5–13. <https://doi.org/10.1007/s11367-012-0476-x>
- Beaussier, T., Caurla, S., Bellon-Maurel, V., Loiseau, E., 2019. Coupling economic models and environmental assessment methods to support regional policies: A critical review. *J. Clean. Prod.* 216, 408–421. <https://doi.org/10.1016/j.jclepro.2019.01.020>
- Beck, T., Bos, U., Wittstock, B., Baitz, M., Fischer, M., Sedlbauer, K., 2010. LANCA- Land Use Indicator Value Calculation in Life Cycle Assessment – Method Report. Fraunhofer Institute for Building Physics and University of Stuttgart. Echterding.
- Bellon-Maurel, V., Aissani, L., Bessou, C., Lardon, L., Loiseau, E., Risch, E., Roux, P., Junqua, G., 2013. What scientific issues in life cycle assessment applied to waste and biomass valorization? Editorial. *Waste and Biomass Valorization* 4, 377–383. <https://doi.org/10.1007/s12649-012-9189-4>
- Beloin-Saint-Pierre, D., Heijungs, R., Blanc, I., 2014. The ESPA (Enhanced Structural Path Analysis) method: A solution to an implementation challenge for dynamic life cycle assessment studies. *Int. J. Life Cycle Assess.* 19, 861–871. <https://doi.org/10.1007/s11367-014-0710-9>
- Beloin-Saint-Pierre, D., Levasseur, A., Margni, M., Blanc, I., 2017. Implementing a Dynamic Life Cycle Assessment Methodology with a Case Study on Domestic Hot Water Production. *J. Ind. Ecol.* 21, 1128–1138. <https://doi.org/10.1111/jiec.12499>
- Benoist, A., 2009. *Éléments d'adaptation de la méthodologie d'analyse de cycle de vie aux carburants végétaux : cas de la première génération.* École Natl. Supérieure des Mines Paris. PhD thesis. École Nationale Supérieure des Mines de Paris.
- Benoist, A., Bessou, C., 2018. Prise en compte en Analyse de Cycle de Vie (ACV) du lien usage des sols – changement climatique : revue critique des méthodologies existantes. *Proj. SOCLE, soil Org. carbon Chang. LCA, which Eval. to Improv. Environ. assessments?* 1–101.
- Benoist, A., Cornillier, C., 2016. Towards a consensual method to assess climate change impacts from bio-based systems, in: 26th SETAC Europe Annual Meeting - Environmental Contaminants from Land to Sea: Continuities and Interface in Environmental Toxicology and Chemistry. Nantes, France.
- Benoist, A., Dron, D., 2009. Integrating GHG dynamics in biomass-based products LCA. *Proc. 4th Int. Conf. Life Cycle Manag.* 6.
- Böhringer, C., Rutherford, T.F., 2008. Combining bottom-up and top-down. *Energy Econ.* 30, 574–596. <https://doi.org/10.1016/j.eneco.2007.03.004>
- Bolwig, S., Gibbon, P., 2009. Counting Carbon in The Marketplace: Part 1 - Overview Paper, Global Forum on Trade - Trade and Climate Change. OECD.
- Bos, U., Horn, R., Beck, T., Lindner, J.P., Fischer, M., 2016. LANCA ® Characterization Factors for Life Cycle Impact Assessment. Version 2.0. Fraunhofer Institute for Building Physics. Fraunhofer Verlag. Stuttgart. Germany.
- Boulay, A., Bayart, J., Bulle, C., Franceschini, H., Motoshita, M., Pfister, S., Margni, M., Centre, E.A., 2015. Analysis of water use impact assessment methods (Part B): Applicability for water footprinting and decision making with a laundry case study. *Int. J. Life Cycle Assess.* 0–18. <https://doi.org/10.1007/s11367-015-0868-9>
- BP, 2018. BP Statistical Review of World Energy 2018: 67 th edition, Statistical Review of World Energy. London, UK.

- Brandão, M., Clift, R., Cowie, A., Greenhalgh, S., 2014. The use of life cycle assessment in the support of robust (climate) policy making: Comment on “Using attributional life cycle assessment to estimate climate-change mitigation.” *J. Ind. Ecol.* 18, 461–463. <https://doi.org/10.1111/jiec.12152>
- Brandão, M., Kirschbaum, M.U.F., Cowie, A.L., Hjulter, S.V., 2019. Quantifying the climate change effects of bioenergy systems: Comparison of 15 impact assessment methods. *GCB Bioenergy* 1–17. <https://doi.org/10.1111/gcbb.12593>
- Brandão, M., Levasseur, A., 2010. Assessing temporary carbon storage in life cycle assessment and carbon footprinting: outcomes of an expert workshop. *JRC 63225*. <https://doi.org/10.2788/22040>
- Brandão, M., Milà i Canals, L., 2013. Global characterisation factors to assess land use impacts on biotic production. *Int. J. Life Cycle Assess.* 18, 1243–1252. <https://doi.org/10.1007/s11367-012-0381-3>
- Brandão, M., Milà i Canals, L., Clift, R., 2011. Soil organic carbon changes in the cultivation of energy crops: Implications for GHG balances and soil quality for use in LCA. *Biomass and Bioenergy* 35, 2323–2336. <https://doi.org/10.1016/j.biombioe.2009.10.019>
- Brander, M., Tripper, R., Hutchison, C., Davis, G., 2009. Consequential and attributional approaches to LCA: a guide to policy makers with specific reference to greenhouse gas LCA of biofuels. *Tech. Pap. TP090403A* 44, 1–14.
- Breton, C., Blanchet, P., Amor, B., 2018. Assessing the Climate Change Impacts of Biogenic Carbon in Buildings: A Critical Review of Two Main Dynamic Approaches. *Sustainability* 10, 1–30. <https://doi.org/10.3390/su10062020>
- Bright, R.M., Cherubini, F., Strømman, A.H., 2012. Climate impacts of bioenergy: Inclusion of carbon cycle and albedo dynamics in life cycle impact assessment. *Environ. Impact Assess. Rev.* 37, 2–11. <https://doi.org/10.1016/j.eiar.2012.01.002>
- BSI, 2008. Guide to PAS 2050: How to assess the carbon footprint of goods and services. British Standard. London.
- Cardellini, G., Mutel, C.L., Vial, E., Muys, B., 2018. Temporalis, a generic method and tool for dynamic life cycle assessment. *Sci. Total Environ.* 645, 585–595. <https://doi.org/10.1016/j.scitotenv.2018.07.044>
- CGIAR, 2018. 4 pour 1000: Preserving soils for carbon capture and food security [WWW Document]. *Res. Progr. Water, L. Ecosyst.* URL <https://wle.cgiar.org/4-pour-1000-preserving-soils-carbon-capture-and-food-security> (accessed 2.1.18).
- Chapin III, F.S., Eviner, V.T., 2007. Chapter 8. Biogeochemistry of terrestrial net primary production, in: Holland, H.D., Turekian, K.K. (Eds.), *Theatise on Geochemistry*, Vol 8. Elsevier Science, pp. 1–35.
- Cherubini, F., Bargigli, S., Ulgiati, S., 2009a. Life cycle assessment (LCA) of waste management strategies: Landfilling, sorting plant and incineration. *Energy* 34, 2116–2123. <https://doi.org/10.1016/j.energy.2008.08.023>
- Cherubini, F., Bright, R.M., Strømman, A.H., 2013. Global climate impacts of forest bioenergy: What, when and how to measure? *Environ. Res. Lett.* 8. <https://doi.org/10.1088/1748-9326/8/2/029503>
- Cherubini, F., Bright, R.M., Strømman, A.H., 2012. Site-specific global warming potentials of biogenic CO₂ for bioenergy: contributions from carbon fluxes and albedo dynamics. *Environ. Res. Lett.* 045902. <https://doi.org/10.1088/1748-9326/7/4/045902>

References

- Cherubini, F., Fuglestvedt, J., Gasser, T., Reisinger, A., Cavalett, O., Huijbregts, M.A.J., Johansson, D.J.A., Jørgensen, S. V., Raugei, M., Schivley, G., Strømman, A.H., Tanaka, K., Levasseur, A., 2016. Bridging the gap between impact assessment methods and climate science. *Environ. Sci. Policy* 64, 129–140. <https://doi.org/10.1016/j.envsci.2016.06.019>
- Cherubini, F., Jungmeier, G., Wellisch, M., Willke, T., Skiadas, I., Ree, R. Van, Jong, E. de, 2009b. Toward a common classification approach for biorefinery systems. *Biofuels, Bioprod. Biorefining* 534–546. <https://doi.org/10.1002/bbb.172>
- Cherubini, F., Peters, G.P., Berntsen, T., Strømman, A.H., Hertwich, E.G., 2011a. CO₂ emissions from biomass combustion for bioenergy: atmospheric decay and contribution to global warming. *GCB Bioenergy* 3, 413–426. <https://doi.org/10.1111/j.1757-1707.2011.01102.x>
- Cherubini, F., Strømman, A.H., Hertwich, E., 2011b. Effects of boreal forest management practices on the climate impact of CO₂ emissions from bioenergy. *Ecol. Modell.* 223, 59–66. <https://doi.org/10.1016/j.ecolmodel.2011.06.021>
- Cherubini, F., Ulgiati, S., 2010. Crop residues as raw materials for biorefinery systems – A LCA case study. *Appl. Energy* 87, 47–57. <https://doi.org/10.1016/j.apenergy.2009.08.024>
- Christensen, T.H., Gentil, E., Boldrin, A., Larsen, A.W., Weidema, B.P., Hauschild, M., 2009. C balance, carbon dioxide emissions and global warming potentials in LCA-modelling of waste management systems. *Waste Manag. Res.* 27, 707–715. <https://doi.org/10.1177/0734242X08096304>
- Ciais, P., Sabine, C., Bala, G., Bopp, L., Brovkin, V., Canadell, J., Chhabra, A., DeFries, R., Galloway, J., Heimann, M., Jones, C., Quéré, C. Le, Myneni, R.B., Piao, S., Thornton, P., 2013. Chapter 3: Carbon and other biogeochemical cycles, in: Stocker, T.F., Qin, D., Plattner, G.-K., Tignor, M., Allen, S.K., Boschung, J., Nauels, A., Xia, Y., Bex, V., Midgley, P.M. (Eds.), *Climate Change 2013: The Physical Science Basis. Contribution of Working Group I to the Fifth Assessment Report of the Intergovernmental Panel on Climate Change*. Cambridge University Press, Cambridge, United Kingdom and New York, pp. 465–570. <https://doi.org/10.1017/CBO9781107415324.015>
- Ciroth, A., Muller, S., Weidema, B., Lesage, P., 2013. Empirically based uncertainty factors for the pedigree matrix in ecoinvent. *Int J Life Cycle Assess* 21, 1338–1348. <https://doi.org/10.1007/s11367-013-0670-5>
- Clark, D.A., Brown, S., Kicklighter, D.W., Chambers, J.Q., Thomlinson, J.R., Ni, J., 2001. Measuring net primary production in forests: Concepts and field methods. *Ecol. Appl.* 11, 356–370. [https://doi.org/10.1890/1051-0761\(2001\)011\[0356:MNPPIF\]2.0.CO;2](https://doi.org/10.1890/1051-0761(2001)011[0356:MNPPIF]2.0.CO;2)
- Clift, R., Brandão, M., 2008. Carbon storage and timing of emissions - a note by Roland Clift and Miguel Brandão, University of Surrey, ISSN: 1464-8083. University of Surrey. Guildford, Surrey.
- Collet, P., 2012. Analyse de cycle de vie de la valorisation énergétique de la biomasse algale : prise en compte des aspects dynamiques dans l'étape d'inventaire. PhD thesis. PhD thesis. University Montpellier SupAgro. Montpellier.
- Collet, P., Lardon, L., Steyer, J.P., Hélias, A., 2014. How to take time into account in the inventory step: A selective introduction based on sensitivity analysis. *Int. J. Life Cycle Assess.* 19, 320–330. <https://doi.org/10.1007/s11367-013-0636-7>
- Cornillier, C., Benoist, A., 2015. Etude préliminaire à la réalisation de bilans environnementaux sur le chauffage au bois – Partie 2 : Mise en œuvre de méthodes de caractérisation d'impact sur le changement climatique, ADEME. ADEME-Agence de l'environnement et de la maîtrise de

- l'énergie. Paris.
- Cornillier, C., Benoist, A., Gleizes, O., 2015. Etude préliminaire à la réalisation de bilans environnementaux sur le chauffage au bois – Synthèse, Ademe.
- Cowell, S.J., Clift, R., 2000. Methodology for assessing soil quantity and quality in life cycle assessment. *J. Clean. Prod.* 8, 321–331. [https://doi.org/10.1016/S0959-6526\(00\)00023-8](https://doi.org/10.1016/S0959-6526(00)00023-8)
- Cowie, A., Berndes, G., Smith, T., 2013. On the timing of greenhouse gas mitigation benefits of forest-based bioenergy. *ExCo:2013:04*. IEA Bioenergy. Dublin.
- Cubasch, U., Wuebbles, D., Chen, D., Facchini, M.C., Frame, D., Mahowald, N., Winther, J.-G., 2013. Chapter 1. Introduction, in: Stocker, T.F., Qin, G.-K., Plattner, M.T., Allen, S.K., Boschung, J., Nauels, A., Xia, V.B., Midgley, P.M. (Eds.), *Climate Change 2013 the Physical Science Basis: Working Group I Contribution to the Fifth Assessment Report of the Intergovernmental Panel on Climate Change*. Cambridge University Press, Cambridge, United Kingdom and New York, NY, USA., pp. 119–158. <https://doi.org/10.1017/CBO9781107415324.007>
- Čuček, L., Klemeš, J.J., Kravanja, Z., 2012. A Review of Footprint analysis tools for monitoring impacts on sustainability. *J. Clean. Prod.* 34, 9–20. <https://doi.org/10.1016/j.jclepro.2012.02.036>
- Curran, M.A., Mann, M., Norris, G., 2005. The international workshop on electricity data for life cycle inventories. *Clean. Prod.* 13, 853e862. <https://doi.org/10.1016/j.jclepro.2002.03.001>
- datascience+, 2018. First steps with Non-Linear Regression in R [WWW Document]. Off. website. URL <https://datascienceplus.com/first-steps-with-non-linear-regression-in-r/> (accessed 12.4.17).
- Davis, C., Nikolic, I., Dijkema, G.P.J., 2009. Integration of life cycle assessment into agent-based modeling toward informed decisions on evolving infrastructure systems. *J. Ind. Ecol.* 13, 306–325. <https://doi.org/10.1111/j.1530-9290.2009.00122.x>
- De Boer, W., Folman, L.B., Summerbell, R.C., Boddy, L., 2005. Living in a fungal world: Impact of fungi on soil bacterial niche development. *FEMS Microbiol. Rev.* 29, 795–811. <https://doi.org/10.1016/j.femsre.2004.11.005>
- De Rosa, M., Schmidt, J., Brandão, M., Pizzol, M., 2017. A flexible parametric model for a balanced account of forest carbon fluxes in LCA. *Int. J. Life Cycle Assess.* 22, 172–184. <https://doi.org/10.1007/s11367-016-1148-z>
- Demertzi, M., Paulo, J.A., Faias, S.P., Arroja, L., Dias, A.C., 2018. Evaluating the carbon footprint of the cork sector with a dynamic approach including biogenic carbon flows. *Int. J. Life Cycle Assess.* 23, 1448–1459. <https://doi.org/10.1007/s11367-017-1406-8>
- Di Gregorio, A., 2016. Land Cover Classification System: Software version 3, October. FAO-Food and Agricultural Organization of the United Nations, Food and Agriculture Organization of the United Nations and the UN-REDD programme.
- Duparque, A., Duranel, J., Dersigny, C., Fleutry, L., 2007. *Mémento Sols et matières organiques: pour des notions utiles et contre les idées reçues*. Agro-Transfert Ressources et Territoires, Picardie. France.
- Dyckhoff, H., Kasah, T., 2014. Time Horizon and Dominance in Dynamic Life Cycle Assessment. *J. Ind. Ecol.* 18, 799–808. <https://doi.org/10.1111/jiec.12131>
- EC-JRC, 2013. Official Journal. Off. J. Eur. Union 56, 216. https://doi.org/doi:10.3000/19770677.L_2013.124.eng
- EC-JRC, 2010. International Reference Life Cycle Data System (ILCD) Handbook: Analysing of

References

- existing Environmental Impact Assessment methodologies for use in Life Cycle Assessment, European Commission. European Commission Joint Research Centre (JRC) contract, Ispra. <https://doi.org/10.2788/38479>
- EC, 2019. European Commission Climate change and EU Action [WWW Document]. Web page Eur. Comm. URL https://ec.europa.eu/clima/policies/strategies_en (accessed 3.1.19).
- EC, 2018a. EU Climate Action: Climate strategies & targets [WWW Document]. Eur. Comm. Platf. URL https://ec.europa.eu/clima/policies/strategies_en (accessed 2.7.18).
- EC, 2018b. Product Environmental Footprint Category Rules Guidance v6.3, PEFCR Guidance document, - Guidance for the development of Product Environmental Footprint Category Rules (PEFCRs), version 6.3. Ispra: JRC-Joint Research Centre, Italy.
- EC, 2018c. Product Environmental Footprint Category Rules Guidance v6.3.
- EC, 2015. Single Market for Green Products Initiative [WWW Document]. URL <http://ec.europa.eu/environment/eussd/smgp/index.htm> (accessed 4.30.15).
- EC, 2010. Being wise with waste: the EU's approach to waste management, European Commission. Publications Office of the European Union. European Commission Brussels. <https://doi.org/10.2779/93543>
- EIBI, 2019. European Industrial Bioenergy Initiative [WWW Document]. URL <http://www.etipbioenergy.eu/index.php> (accessed 9.10.19).
- Ekvall, T., Azapagic, A., Finnveden, G., Rydberg, T., Weidema, B.P., Zamagni, A., 2016. Attributional and consequential LCA in the ILCD handbook. *Int. J. Life Cycle Assess.* 293–296. <https://doi.org/10.1007/s11367-015-1026-0>
- Ekvall, T., Finnveden, G., 2001. Allocation in ISO 14041—a critical review. *J. Clean. Prod.* 9, 197–208. [https://doi.org/10.1016/S0959-6526\(00\)00052-4](https://doi.org/10.1016/S0959-6526(00)00052-4)
- EPA, 2017. Global Greenhouse Gas emissions [WWW Document]. Web page US Environ. Prot. Agency. URL <https://www.epa.gov/ghgemissions> (accessed 3.30.19).
- EPA, 2014. Framework for assessing biogenic CO₂ emissions from stationary sources, United States Environmental Protection Agency. Office of Air and Radiation Office of Atmospheric Programs, Climate Change Division.
- Ericsson, N., Porsö, C., Åhlgren, S., Nordberg, Å., Sundberg, C., Hansson, P.A., 2013. Time-dependent climate impact of a bioenergy system - methodology development and application to Swedish conditions. *GCB Bioenergy* 5, 580–590. <https://doi.org/10.1111/gcbb.12031>
- Eurostat, 2019. Climate change - driving forces [WWW Document]. Web page Eurostat. URL [https://ec.europa.eu/eurostat/statistics-explained/index.php?title=File:Greenhouse_gas_emissions_by_IPCC_source_sector,_EU28,_change_from_1990_to_2016_\(million_tonnes_of_CO2_equivalent_and_%25_change\).png](https://ec.europa.eu/eurostat/statistics-explained/index.php?title=File:Greenhouse_gas_emissions_by_IPCC_source_sector,_EU28,_change_from_1990_to_2016_(million_tonnes_of_CO2_equivalent_and_%25_change).png) (accessed 3.1.19).
- Fantke, P., Jolliet, O., Wannaz, C., 2015. Dynamic toxicity modelling based on the USEtox matrix framework, in: Abstract Book - SETAC Europe 25th Annual Meeting, Barcelona, 3-7 May 2015. pp. 2–3.
- FAO, 2019. Food and Agriculture Organization of the United Nations: Resources [WWW Document]. Web page. URL <http://www.fao.org/resources/infographics/en/> (accessed 3.12.19).
- FAO, 2018a. The State of Food Security and Nutrition in the World 2018. Building climate resilience

- for food security and nutrition. Rome: FAO, IFAD, UNICEF, WFP and WHO.
- FAO, 2018b. Measuring and modelling soil carbon stocks and stock changes in livestock production systems: Guidelines for assessment (Draft for public review), FAO publications. Livestock Environmental Assessment and Performance (LEAP) Partnership. Rome, Italy.
- FAO, 2005. Knowledge reference for national forest assessments - modeling for estimation and monitoring [WWW Document]. Food Agric. Organ. United Nations. URL <http://www.fao.org/forestry/17111/en/> (accessed 5.3.17).
- FAO, 2004. Assessing carbon stocks and modelling win-win scenarios of carbon sequestration through land-use changes. FAO-Food and Agriculture Organisation of the United Nations. Rome.
- Fearnside, Philip M, 2002. Time preference in global warming calculations : a proposal for a unified index. *Ecol. Econ.* 41, 21–31. [https://doi.org/https://doi.org/10.1016/S0921-8009\(02\)00004-6](https://doi.org/https://doi.org/10.1016/S0921-8009(02)00004-6)
- Fearnside, P M, 2002. Why a 100-Year Time Horizon should be used for Global Warming Mitigation Calculations. *Mitig. Adapt. Strateg. Glob. Chang.* 7, 19–30. <https://doi.org/10.1023/A:1015885027530>
- Fearnside, P.M., Lashof, D.A., Moura-Costa, P., 2000. Accounting for time in mitigating global warming through land-use change and forestry. *Kluwer Acad. Publ.* 5, 239–270. <https://doi.org/10.1023/A:1009625122628>
- Fekedulegn, D., Mac Siurtain, M.P., Colbert, J.J., 1999. Parameter estimation of nonlinear growth models in forestry. *Silva Fenn.* 33, 327–336. <https://doi.org/10.14214/sf.653>
- Finkbeiner, M., 2013. Indirect land use change (iLUC) within life cycle assessment (LCA) – scientific robustness and consistency with international standards. Association of German Biofuels Producers (VDB) and Association of oilseed processing industry in Germany (OVID).
- Finkbeiner, M., Ackermann, R., Bach, V., Berger, M., Brankatschk, G., Chang, Y.-J., Grinberg, M., Lehmann, A., Martínez-Blanco, J., Minkov, N., Neugebauer, S., Scheumann, R., Schneider, L., Wolf, K., 2013. Chapter 7 Challenges in Life Cycle Assessment: An Overview of Current Gaps and Research Needs, in: Klöpffer, W. (Ed.), *Background and Future Prospects in Life Cycle Assessment, LCA Compendium – The Complete World of Life Cycle Assessment*. Springer Science+Business Media, Dordrecht, pp. 207–258. <https://doi.org/10.1017/CBO9781107415324.004>
- Finnveden, G., Hauschild, Z.M., Ekvall, T., Guinée, J., Heijungs, R., Hellweg, S., Koehler, A., Pennington, D., Suh, S., 2009. Recent developments in Life Cycle Assessment. *J. Environ. Manage.* 91, 1–21. <https://doi.org/10.1016/j.jenvman.2009.06.018>
- Forster, P., Ramaswamy, V., Artaxo, P., Bernsten, T., Betts, R., Fahey, D.W., Haywood, J., Lean, J., Lowe, D.C., Myhre, G., Nganga, J., Prinn, R., Raga, G., Schulz, M., R. Van Dorland, 2007. Chapter 2: Changes in Atmospheric Constituents and in Radiative Forcing, in: Solomon, S., Qin, D., Manning, M., Chen, Z., Marquis, M., Averyt, K.B., M. Tignor, Miller, H.L. (Eds.), *Climate Change 2007: The Physical Science Basis. Contribution of Working Group I to the Fourth Assessment Report of the Intergovernmental Panel on Climate Change*. Cambridge University Press, Cambridge, United Kingdom and New York, pp. 129–234. <https://doi.org/10.1103/PhysRevB.77.220407>
- Fouquet, M., Lévassieur, A., Margni, M., Lebert, A., Lasvaux, S., Souyri, B., Buhé, C., Woloszyn, M., 2015. Methodological challenges and developments in LCA of low energy buildings: Application to biogenic carbon and global warming assessment. *Build. Environ.* 90, 51–59. <https://doi.org/10.1016/j.buildenv.2015.03.022>
- Franko, U., Crocker, G.J., Grace, P.R., Klir, J., Körschens, M., Poulton, P.R., Richter, D.D., 2002.

References

- Simulating trends in soil organic carbon in long-term experiments using the CANDY model. *Geoderma* 81, 5–28. [https://doi.org/10.1016/s0016-7061\(97\)88181-5](https://doi.org/10.1016/s0016-7061(97)88181-5)
- Freidberg, S., 2013. Calculating sustainability in supply chain capitalism. *Econ. Soc.* 00, 1–26. <https://doi.org/10.1080/03085147.2012.760349>
- Frischknecht, R., Althaus, H., Bauer, C., Doka, G., Heck, T., Jungbluth, N., Kellenberger, D., Nemecek, T., 2007. The Environmental Relevance of Capital Goods in Life Cycle Assessments of Products and Services. *Int. J. Life Cycle Assess.* 12, 7–17. <https://doi.org/10.1065/lca2007.02.309>
- Frischknecht, R., Benetto, E., Dandres, T., Heijungs, R., Roux, C., Schrijvers, D., Wernet, G., Yang, Y., Messmer, A., Tschuemperlin, L., 2016. LCA and decision making: when and how to use consequential LCA; 62nd LCA forum, Swiss Federal Institute of Technology, Zürich, 9 September 2016. *Int. J. Life Cycle Assess.* 296–301. <https://doi.org/10.1007/s11367-016-1248-9>
- Frischknecht, R., Stucki, M., 2010. Scope-dependent modelling of electricity supply in life cycle assessments. *Int. J. Life Cycle Assess.* 15, 806–816. <https://doi.org/10.1007/s11367-010-0200-7>
- Fuglestvedt, J.S., Berntsen, T.K., Godal, O., Sausen, R., Shine, K.P., Skodvin, T., 2003. Metrics of climate change: Assessing radiative forcing and emission indices. *Clim. Change* 58, 267–331. <https://doi.org/10.1023/A:1023905326842>
- Fuglestvedt, J.S., Shine, K.P., Berntsen, T., Cook, J., Lee, D.S., Stenke, A., Skeie, R.B., Velders, G.J.M., Waitz, I.A., 2010. Transport impacts on atmosphere and climate: Metrics. *Atmos. Environ.* 44, 4648–4677. <https://doi.org/10.1016/j.atmosenv.2009.04.044>
- Fukushima, Y., Hirao, M., 2002. LCA Methodology A Structured Framework and Language for Scenario-Based Life Cycle Assessment. *Int J Life Cycle Assess.* 7, 317–329. <https://doi.org/10.1065/Bca2002.06.085> Abstract,
- Gabel, V.M., Meier, M.S., Köpke, U., Stolze, M., 2016. The challenges of including impacts on biodiversity in agricultural life cycle assessments. *J. Environ. Manage.* 181, 249–260. <https://doi.org/10.1016/j.jenvman.2016.06.030>
- Gao, T., Liu, Q., Wang, J., 2014. A comparative study of carbon footprint and assessment standards. *Int. J. Low-Carbon Technol.* 9, 237–243. <https://doi.org/10.1093/ijlct/ctt041>
- Garrigues, E., Corson, M.S., Angers, D.A., 2013. Development of a soil compaction indicator in life cycle assessment. *Int J Life Cycle Assess* 18, 1316–1324. <https://doi.org/10.1007/s11367-013-0586-0>
- Garrigues, E., Corson, M.S., Angers, D.A., Werf, H.M.G. Van Der, Walter, C., 2012. Soil quality in Life Cycle Assessment: Towards development of an indicator. *Ecol. Indic.* 18, 434–442. <https://doi.org/10.1016/j.ecolind.2011.12.014>
- Gibbs, H.K., Johnston, M., Foley, J.A., Holloway, T., Monfreda, C., Ramankutty, N., Zaks, D., 2008. Carbon payback times for crop-based biofuel expansion in the tropics: The effects of changing yield and technology. *Environ. Res. Lett.* 3. <https://doi.org/10.1088/1748-9326/3/3/034001>
- Gibon, T., Wood, R., Arvesen, A., Bergesen, J.D., Suh, S., Hertwich, E.G., 2015. A Methodology for Integrated, Multiregional Life Cycle Assessment Scenarios under Large-Scale Technological Change. *Environ. Sci. Technol.* 49, 11218–11226. <https://doi.org/10.1021/acs.est.5b01558>
- Giuntoli, J., Agostini, A., Caserini, S., Lugato, E., Baxter, D., Marelli, L., 2016. Climate change impacts of power generation from residual biomass. *Biomass and Bioenergy* 89, 146–158. <https://doi.org/10.1016/j.biombioe.2016.02.024>

- Giuntoli, J., Caserini, S., Marelli, L., Baxter, D., Agostini, A., 2015. Domestic heating from forest logging residues: Environmental risks and benefits. *J. Clean. Prod.* 99, 206–216. <https://doi.org/10.1016/j.jclepro.2015.03.025>
- Gnansounou, E., Panichelli, L., Dauriat, A., Villegas, J.D., 2008. Accounting for indirect land-use changes in GHG balances of biofuels. Review of current approaches. Working paper ref. 437.101. École Polytechnique Fédérale de Lausanne.
- Goedkoop, M., Heijungs, R., De Schryver, A., Struijs, J., van Zelm, R., 2013. ReCiPe 2008. A LCIA method which comprises harmonised category indicators at the midpoint and the endpoint level. Characterisation. <https://doi.org/http://www.lcia-recipe.net>
- Goedkoop, M., Spriemsma, R., 2001. The Eco-indicator 99 A damage oriented method for Life Cycle Impact Assessment, *International Journal of Life Cycle Assessment*. PRÉ Consultants B.V. Amersfoort. Netherlands.
- Goglio, P., Grant, B.B., Smith, W.N., Desjardins, R.L., Worth, D.E., Zentner, R., Malhi, S.S., 2014. Impact of management strategies on the global warming potential at the cropping system level. *Sci. Total Environ.* 490, 921–933. <https://doi.org/10.1016/j.scitotenv.2014.05.070>
- Goglio, P., Smith, W.N., Grant, B.B., Desjardins, R.L., McConkey, B.G., Campbell, C.A., Nemecek, T., 2015. Accounting for soil carbon changes in agricultural life cycle assessment (LCA): A review. *J. Clean. Prod.* 104, 23–39. <https://doi.org/10.1016/j.jclepro.2015.05.040>
- Gou, L., Gifford, R.M., 2002. Soil carbon stocks and land use change : a meta analysis. *Glob. Chang. Biol.* 345–360. <https://doi.org/10.1046/j.1354-1013.2002.00486.x>
- Gower, S.T., Krankina, O., Olson, R.J., Apps, M., Linder, S., Wang, C., 2001. Net primary production and carbon allocation patterns of boreal forest ecosystems. *Ecol. Appl.* 11, 1395–1411. [https://doi.org/10.1890/1051-0761\(2001\)011\[1395:NPPACA\]2.0.CO;2](https://doi.org/10.1890/1051-0761(2001)011[1395:NPPACA]2.0.CO;2)
- Grace, P.R., Ladd, J.N., Robertson, G.P., Gage, S.H., 2006. SOCRATES-A simple model for predicting long-term changes in soil organic carbon in terrestrial ecosystems. *Soil Biol. Biochem.* 38, 1172–1176. <https://doi.org/10.1016/j.soilbio.2005.09.013>
- Grassi, G., House, J., Dentener, F., Federici, S., den Elzen, M., Penman, J., 2017. The key role of forests in meeting climate targets requires science for credible mitigation. *Nat. Clim. Chang.* 7, 220.
- Guest, G., Cherubini, F., Strømman, A.H., 2012. Global Warming Potential of Carbon Dioxide Emissions from Biomass Stored in the Anthroposphere and Used for Bioenergy at End of Life. *J. Ind. Ecol.* 17. <https://doi.org/10.1111/j.1530-9290.2012.00507.x>
- Guest, G., Strømman, A.H., 2014. Climate Change Impacts Due to Biogenic Carbon : Addressing the Issue of Attribution Using Two Metrics With Very Different Outcomes Climate Change Impacts Due to Biogenic Carbon : Addressing the Issue of Attribution. *J. Sustain. For.* 33, 298–326. <https://doi.org/10.1080/10549811.2013.872997>
- Guinée, B.J., Heijungs, R., Huppes, G., Zamagni, A., Masoni, P., Buonamici, R., Ekvall, T., Rydberg, T., 2011. Life Cycle Assessment: Past, Present, and Future. *Environ. Sci. Technol.* 45, 90–96. <https://doi.org/10.1021/es101316v>
- Guinée, J.B., Cucurachi, S., Henriksso, P.J.G., Heijungs, R., 2018. Digesting the alphabet soup of LCA. *Int. J. Life Cycle Assess.* 1507–1511. <https://doi.org/10.1007/s11367-018-1478-0>
- Guinée, J.B., Heijungs, R., Huppes, G., Kleijn, R., de Koning, A., van Oers, L., Wegener Sleeswijk, A., Suh, S., Udo de Haes, H. a., de Bruijn, H., van Duin, R., Huijbregts, M. a. J., Gorrée, M., 2001. Life Cycle Assessment: An Operational Guide to the ISO Standards. Den Haag, The

- Netherlands. <https://doi.org/10.1007/BF02978784>
- Haberl, H., Sprinz, D., Bonazountas, M., Cocco, P., Desaubies, Y., Henze, M., Hertel, O., Johnson, R.K., Kastrup, U., Laconte, P., Lange, E., Novak, P., Paavola, J., Reenberg, A., Hove, S. Van Den, Vermeire, T., Wadhams, P., Searchinger, T., 2012. Correcting a fundamental error in greenhouse gas accounting related to bioenergy. *Energy Policy* 45, 18–23. <https://doi.org/10.1016/j.enpol.2012.02.051>
- Hall, L.M.H., Buckley, A.R., 2016. A review of energy systems models in the UK: Prevalent usage and categorisation. *Appl. Energy* 169, 607–628. <https://doi.org/10.1016/j.apenergy.2016.02.044>
- Hamelin, L., Jørgensen, U., Petersen, B.M., Olesen, J.E., Wenzel, H., 2012. Modelling the carbon and nitrogen balances of direct land use changes from energy crops in Denmark: A consequential life cycle inventory. *GCB Bioenergy* 4, 889–907. <https://doi.org/10.1111/j.1757-1707.2012.01174.x>
- Harvey, M., Pilgrim, S., 2011. The new competition for land: Food, energy, and climate change. *Food Policy* 36, S40–S51. <https://doi.org/10.1016/j.foodpol.2010.11.009>
- Hauschild, M., Huijbregts, M.A.J., 2015. Chapter 1: Introducing Life Cycle Impact Assessment, in: Hauschild, M.Z., Huijbregts, M.A.J. (Eds.), *Life Cycle Impact Assessment, LCA Compendium – The Complete World of Life Cycle Assessment*. Springer Science+Business Media Dordrecht, pp. 1–16. <https://doi.org/10.1007/978-94-017-9744-3>
- Hauschild, M.Z., 2005. Assessing environmental impacts in a life cycle perspective. *Environ. Sci. Technol.* 81A-88A. <https://doi.org/10.1021/es053190s>
- Heaps, C.G., 2016. Long-range Energy Alternatives Planning (LEAP) system. [Software version: 2018.1.27]. Stockholm Environment Institute. Somerville, MA, USA.
- Heijungs, R., De Koning, A., Guinée, J.B., 2014. Maximizing affluence within the planetary boundaries. *Int. J. Life Cycle Assess.* 19, 1331–1335. <https://doi.org/10.1007/s11367-014-0729-y>
- Heijungs, R., Huijbregts, M. a J., 2004. A review of approaches to treat uncertainty in LCA, in: *International Congress on Environmental Modelling and Software*.197. <https://doi.org/http://www.iemss.org/iemss2004/pdf/lca/heijarev.pdf>
- Heijungs, R., Suh, S., 2002. The computational structure of life cycle assessment. *Kluwer Acad. Publ.* 7, 314–314. <https://doi.org/10.1007/BF02978899>
- Hellweg, S., Frischknecht, R., 2004. Evaluation of long-term impacts in LCA. *Conf. Reports 22nd Discuss. Forum LCA* 9, 339–341. <https://doi.org/10.1007/BF02979427>
- Hellweg, S., Hofstetter, T.B., Hungerbuhler, K., 2003. Discounting and the environment - Should current impacts be weighted differently than impacts harming future generations? *Int. J. Life Cycle Assess.* 8, 8–18. <https://doi.org/10.1065/lca2002.09.097>
- Henin, S., Dupuis, M., 1945. Essai de bilan de la matière organique du sol. *Ann. Agron.* 1, 19–29.
- Henriksson, P.J.G., Guinée, J.B., Heijungs, R., de Koning, A., Green, D.M., 2013. A protocol for horizontal averaging of unit process data—including estimates for uncertainty. *Int. J. Life Cycle Assess.* 19, 429–436. <https://doi.org/10.1007/s11367-013-0647-4>
- Henry, M., Bombelli, A., Trotta, C., Alessandrini, A., Birigazzi, L., Sola, G., Vieilledent, G., Santenoise, P., Longuetaud, F., Valentini, R., Picard, N., Saint-André, L., 2013. GlobAllomeTree: International platform for tree allometric equations to support volume, biomass and carbon assessment. *IForest* 6, 326–330. <https://doi.org/10.3832/ifor0901-006>
- Henson, I. e, 2007. Modelling Oil Palm Bunch Components , Palm Oil and Kernel Yields. *Oil Palm*

- Bull. 55, 15–25.
- Hertwich, E.G., Gibon, T., Bouman, E.A., Arvesen, A., Suh, S., Heath, G.A., Bergesen, J.D., Ramirez, A., Vega, M.I., Shi, L., 2014. Integrated life-cycle assessment of electricity-supply scenarios confirms global environmental benefit of low-carbon technologies. *Proc. Natl. Acad. Sci.* 112, 6277–6282. <https://doi.org/10.1073/pnas.1312753111>
- Hillier, J., Brentrup, F., Wattenbach, M., Walter, C., Garcia-Suarez, T., Mila-i-Canals, L., Smith, P., 2012. Which cropland greenhouse gas mitigation options give the greatest benefits in different world regions? Climate and soil-specific predictions from integrated empirical models. *Glob. Chang. Biol.* 18, 1880–1894. <https://doi.org/10.1111/j.1365-2486.2012.02671.x>
- Hillier, J., Whittaker, C., Dailey, G., Aylott, M., Casella, E., Richter, G., Riche, A., Murphy, R.J., Taylor, G., Smith, P., 2009. Greenhouse gas emissions from four bioenergy crops in England and Wales: Integrating spatial estimates of yield and soil carbon balance in life cycle analyses. *GCB Bioenergy* 1, 267–281. <https://doi.org/10.1111/j.1757-1707.2009.01021.x>
- Hoffmann, W.A., Poorter, H., 2002. Avoiding bias in calculations of relative growth rate. *Ann. Bot.* 90, 37–42. <https://doi.org/10.1093/aob/mcf140>
- Hofstetter, P., Baumgartner, T., Scholz, R., 2000. Modelling the Valuesphere and the Ecosphere: integrating the decision makers' perspectives into LCA. *Int. J. Life Cycle Assess.* 5, 161–175. <https://doi.org/10.1007/BF02978618>
- Holtmark, B., 2015. Quantifying the global warming potential of CO₂ emissions from wood fuels. *GCB Bioenergy* 7, 195–206. <https://doi.org/10.1111/gcbb.12110>
- Hourcade, J.C., Robinson, J., 1996. Mitigating factors: Assessing the costs of reducing GHG emissions. *Energy Policy* 24, 863–873.
- Howells, M., Rogner, H., Strachan, N., Heaps, C., Huntington, H., Kypreos, S., Hughes, A., Silveira, S., DeCarolis, J., Bazillian, M., Roehrl, A., 2011. OSeMOSYS: The Open Source Energy Modeling System. An introduction to its ethos, structure and development. *Energy Policy* 39, 5850–5870. <https://doi.org/10.1016/j.enpol.2011.06.033>
- Huijbregts, M.A.J., Guin, J.B., Reijnders, L., 2001. Priority assessment of toxic substances in life cycle assessment . III : Export of potential impact over time and space. *Chemosphere* 44, 59–65. [https://doi.org/10.1016/s0045-6535\(00\)00349-0](https://doi.org/10.1016/s0045-6535(00)00349-0)
- Huijbregts, M.A.J., Steinmann, Z.J.N., Elshout, P.M.F., Stam, G., Verones, F., Vieira, M.D.M., Zelm, R. Van, 2016a. A harmonized life cycle impact assessment method at midpoint and endpoint level. Report I: Characterization. Nijmegen.
- Huijbregts, M.A.J., Steinmann, Z.J.N., Elshout, P.M.F., Stam, G., Verones, F., Vieira, M.D.M., Zelm, R. Van, 2016b. ReCiPe2016 A harmonized life cycle impact assessment method at midpoint and endpoint level. Report I: Characterization. Department of Environmental Science, Radboud University. Nijmegen.
- Hunt, 1990. *Basic Growth Analysis: Plant growth analysis for beginners*. Springer Science & Business Media, Unwin Hyman, London.
- Hunt, R., 1982. *Plant growth curves. The functional approach to plant growth analysis*. Edward Arnold Ltd., London.
- Hunter, K., Sreepathi, S., DeCarolis, J.F., 2013. Modeling for insight using Tools for Energy Model Optimization and Analysis (Temoa). *Energy Econ.* 40, 339–349. <https://doi.org/10.1016/j.eneco.2013.07.014>

References

- IGN, 2017. Le mémento inventaire forestier édition 2017 [WWW Document]. IGN-Institut Natl. l'information géographique For. URL https://inventaire-forestier.ign.fr/IMG/pdf/memento_2017.pdf (accessed 7.20.18).
- Imbeault-Tétreault, H., Jolliet, O., Deschênes, L., Rosenbaum, R.K., 2013. Analytical propagation of uncertainty in life cycle assessment using matrix formulation. *J. Ind. Ecol.* 17, 485–492. <https://doi.org/10.1111/jiec.12001>
- INRA, 2019. Stocker du carbone dans les sols français : quel potentiel au regard de l'objectif 4 pour 1000 et à quel cout? Réalisée pour l'ADEME et le Ministère de l'Agriculture et de l'Alimentation. Paris.
- Jordan, C., Lousselet, C., Cherubini, F., 2016. Life-cycle assessment of a biogas power plant with application of different climate metrics and inclusion of near-term climate forcers. *J. Environ. Manage.* 184, 517–527. <https://doi.org/10.1016/j.jenvman.2016.10.030>
- IPCC, 2018. Intergovernmental Panel on Climate Change [WWW Document]. Wep page IPCC. URL <http://www.ipcc.ch/> (accessed 2.2.18).
- IPCC, 2013a. Climate Change 2013 The Physical Science Basis. Contribution of Working Group I to the Fifth Assessment Report of the Intergovernmental Panel on Climate Change. Cambridge University Press, Cambridge and New York. <https://doi.org/10.1017/CBO9781107415324.Summary>
- IPCC, 2013b. Annex III: Glossary [Planton, S. (ed.)], in: Stocker, T.F., Qin, D., Plattner, G.-K., Tignor, M., Allen, S.K., Boschung, J., Nauels, A., Xia, Y., Bex, V., Midgley, P.M. (Eds.), Climate Change 2013: The Physical Science Basis. Contribution of Working Group I to the Fifth Assessment Report of the Intergovernmental Panel on Climate Change. Cambridge University Press, Cambridge, United Kingdom and New York, NY, USA. 1447, pp. 1447–1466. <https://doi.org/10.1017/CBO9781107415324.031>
- IPCC, 2006a. Chapter 4. Agriculture, Forestry and other Land Use, in: Eggleston, S., Buendia, L., Miwa, K., Ngara, T., Tanabe, K. (Eds.), 2006 IPCC Guidelines for National Greenhouse Gas Inventories. Intergovernmental Panel on Climate Change, Prepared by the National Greenhouse Gas Inventories Programme.
- IPCC, 2006b. 2006 IPCC Guidelines for National Greenhouse Gas Inventories. The Intergovernmental Panel on Climate Change (IPCC).
- IPCC, 2000. Land Use, Land-Use Change, and Forestry: A Special Report of the Intergovernmental Panel on Climate Change, Forestry. <https://doi.org/DOI:10.2277/0521800838>
- IPCC, 1990. Climate Change The IPCC Scientific Assessment, Cambridge University Press. New York, Port Chester, Melbourne, Sydney. <https://doi.org/10.1097/MOP.0b013e3283444c89>
- ISO, 2013. ISO/TS 14067: Greenhouse gases — Carbon footprint of products — Requirements and guidelines for quantification and communication. Geneva.
- ISO, 2006a. ISO 14040 Environmental management — Life cycle assessment — Principles and framework. The International Standards Organisation. Geneva.
- ISO, 2006b. ISO 14044 Environmental management — Life cycle assessment — Requirements and guidelines. The International Standards Organisation. Geneva.
- Jenkinson, D.S., Coleman, K., 1994. Calculating the annual input of organic matter to soil from measurements of total organic carbon and radiocarbon. *Eur. J. Soil Sci.* 45, 167–174. <https://doi.org/10.1111/j.1365-2389.1994.tb00498.x>

- Jeswani, H.K., Azapagic, A., Schepelmann, P., Ritthoff, M., 2010. Options for broadening and deepening the LCA approaches. *J. Clean. Prod.* 18, 120–127. <https://doi.org/10.1016/j.jclepro.2009.09.023>
- Johnson, E., 2009. Goodbye to carbon neutral: Getting biomass footprints right. *Environ. Impact Assess. Rev.* 29, 165–168. <https://doi.org/10.1016/j.eiar.2008.11.002>
- Jolliet, O., Dubreuil, A., Gloria, T., Hauschild, M., 2005. Progresses: Progresses in Life Cycle Impact Assessment within the UNEP/SETAC Life Cycle Initiative. *Int J Life Cycle Assess* 10, 447–448. <https://doi.org/10.1065/lca2005.11.006>
- Jolliet, P.O., Saade-Sbeih, M., Shaked, S., Jolliet, A., Crettaz, P., 2015. *Environmental Life Cycle Assessment*. CRC Press Taylor & Francis Group.
- Joos, F., Bruno, M., 1996. Pulse response functions are cost-efficient tools to model the link between carbon emissions, atmospheric CO₂ and global warming. *Phys. Chem. Earth* 21, 471–476. [https://doi.org/10.1016/S0079-1946\(97\)81144-5](https://doi.org/10.1016/S0079-1946(97)81144-5)
- Joos, F., Roth, R., Fuglestvedt, J.S., Peters, G.P., Enting, I.G., Von Bloh, W., Brovkin, V., Burke, E.J., Eby, M., Edwards, N.R., Friedrich, T., Frölicher, T.L., Halloran, P.R., Holden, P.B., Jones, C., Kleinen, T., Mackenzie, F.T., Matsumoto, K., Meinshausen, M., Plattner, G.K., Reisinger, A., Segschneider, J., Shaffer, G., Steinacher, M., Strassmann, K., Tanaka, K., Timmermann, A., Weaver, A.J., 2013. Carbon dioxide and climate impulse response functions for the computation of greenhouse gas metrics: A multi-model analysis. *Atmos. Chem. Phys.* 13, 2793–2825. <https://doi.org/10.5194/acp-13-2793-2013>
- Jørgensen, S.V., Hauschild, M.Z., Nielsen, P.H., 2014. Assessment of urgent impacts of greenhouse gas emissions — the climate tipping potential (CTP). *Int. J. Life Cycle Assess.* <https://doi.org/10.1007/s11367-013-0693-y>
- Jørgensen, S. V, Hauschild, M.Z., 2013. Need for relevant timescales when crediting temporary carbon storage. *Int. J. Life Cycle Assess.* 747–754. <https://doi.org/10.1007/s11367-012-0527-3>
- Jørgensen, S. V, Hauschild, M.Z., Nielsen, P.H., 2015. The potential contribution to climate change mitigation from temporary carbon storage in biomaterials. *Int. J. Life Cycle Assessment Cycle Assess* 451–462. <https://doi.org/10.1007/s11367-015-0845-3>
- Kendall, A., 2012. Time-adjusted global warming potentials for LCA and carbon footprints. *Int J Life Cycle Assess* 1042–1049. <https://doi.org/10.1007/s11367-012-0436-5>
- Kendall, A., Davis, A., Studies, T., Shields, O., Davis, A., Sharpe, B., 2009. Accounting for time-dependent effects in biofuel life cycle greenhouse gas emissions calculations. *Environ. Sci. Technol.* 43, 7142–7147. <https://doi.org/10.1021/es900529u>
- Kendall, A., Price, L., 2012. Incorporating Time-Corrected Life Cycle Greenhouse Gas Emissions in Vehicle Regulations. *Environ. Sci. Technol.* 46, 2557–2563. <https://doi.org/10.1021/es203098j>
- Keppo, I., Strubegger, M., 2010. Short term decisions for long term problems - The effect of foresight on model based energy systems analysis. *Energy* 35, 2033–2042. <https://doi.org/10.1016/j.energy.2010.01.019>
- Kim, S., Dale, B.E., Jenkins, R., 2009. Life cycle assessment of corn grain and corn stover in the United States. *Int. J. Life Cycle Assess.* 14, 160–174. <https://doi.org/10.1007/s11367-008-0054-4>
- Kimming, M., Sundberg, C., Nordberg, Å., Baky, A., Bernesson, S., Norén, O., Hansson, P.A., 2011. Biomass from agriculture in small-scale combined heat and power plants - A comparative life cycle assessment. *Biomass and Bioenergy* 35, 1572–1581. <https://doi.org/10.1016/j.biombioe.2010.12.027>

References

- Kirschbaum, M.U.F., 2014. Climate-change impact potentials as an alternative to global warming potentials. *Environ. Res. Lett.* 9. <https://doi.org/10.1088/1748-9326/9/3/034014>
- Kirschbaum, M.U.F., 2003. Can Trees Buy Time? An Assessment of the Role of Vegetation Sinks as Part of the Global Carbon Cycle. *Clim. Chang.* 58, 47–71. <https://doi.org/10.1023/A>
- Kirschbaum, M.U.F.F., 2000. Will Changes in Soil Organic Carbon Act as a Positive or Negative Feedback on Global Warming? *Biogeochemistry* 48, 21–51. <https://doi.org/10.1023/A:1006238902976>
- Klöpffer, W., 2014. Chapter 1: Introducing Life Cycle Assessment and its Presentation in ‘LCA Compendium,’ in: Klöpffer, W. (Ed.), *Background and Future Prospects in Life Cycle Assessment, LCA Compendium – The Complete World of Life Cycle Assessment*, Springer Science+Business Media Dordrecht, Dordrecht, pp. 1–37. <https://doi.org/10.1017/CBO9781107415324.004>
- Klöpffer, W., 2008. State-of-the-Art in Life Cycle Sustainability Assessment (LCSA): Life Cycle Sustainability Assessment of Products (with comments by Helias A. Udo de Haes). *Int. J. Life Cycle Assess.* 13, 89–95. <https://doi.org/10.1065/lca2008.02.376> Please
- Klöpffer, W., 2003. Life-Cycle Based Methods for Sustainable Product Development 8, 157–159. <https://doi.org/10.1007/BF02978462>
- Knoeri, C., Wäger, P.A., Stamp, A., Althaus, H.J., Weil, M., 2013. Towards a dynamic assessment of raw materials criticality: Linking agent-based demand - With material flow supply modelling approaches. *Sci. Total Environ.* 461–462, 808–812. <https://doi.org/10.1016/j.scitotenv.2013.02.001>
- Knudsen, M.T., Meyer-Aurich, A., Olesen, J.E., Chirinda, N., Hermansen, J.E., 2014. Carbon footprints of crops from organic and conventional arable crop rotations - Using a life cycle assessment approach. *J. Clean. Prod.* 64, 609–618. <https://doi.org/10.1016/j.jclepro.2013.07.009>
- Koellner, T., Baan, L., Beck, T., Brandão, M., Civit, B., Margni, M., Canals, L.M., Saad, R., Souza, D.M., Müller-Wenk, R., 2013a. UNEP-SETAC guideline on global land use impact assessment on biodiversity and ecosystem services in LCA. *Int. J. Life Cycle Assess.* 18, 1188–1202. <https://doi.org/10.1007/s11367-013-0579-z>
- Koellner, T., de Baan, L., Beck, T., Brandão, M., Civit, B., Goedkoop, M., Margni, M., i Canals, L.M., Müller-Wenk, R., Weidema, B., Wittstock, B., 2013b. Principles for life cycle inventories of land use on a global scale. *Int. J. Life Cycle Assess.* 18, 1203–1215. <https://doi.org/10.1007/s11367-012-0392-0>
- Koellner, T., Scholz, R.W., 2007. Assessment of land use impacts on the natural environment. Part 1: an analytical framework for pure land occupation and land use change. *Int. J. Life Cycle Assess.* 12, 16–23. <https://doi.org/10.1065/lca2006.12.292.1>
- Koponen, K., Soimakallio, S., 2015. Foregone carbon sequestration due to land occupation — the case of agro-bioenergy in Finland 1544–1556. <https://doi.org/10.1007/s11367-015-0956-x>
- Lal, R., 2008. Carbon sequestration. *Philos Trans R Soc L. B Biol Sci* 363, 815–830. <https://doi.org/10.1098/rstb.2007.2185>
- Lal, R., 2005. Forest soils and carbon sequestration. *For. Ecol. Manage.* 220, 242–258. <https://doi.org/10.1016/j.foreco.2005.08.015>
- Lal, R., 2004. Soil carbon sequestration to mitigate climate change. *Geoderma* 123, 1–22. <https://doi.org/10.1016/j.geoderma.2004.01.032>

- Lamers, P., Junginger, M., 2013. The “debt” is in the detail : A synthesis of recent temporal forest carbon analyses on woody biomass for energy. *Biofuels Bioprod. Biorefining*. <https://doi.org/10.1002/bbb.1407>
- Lebailly, F., Levasseur, A., Samson, R., Deschênes, L., 2014. Development of a dynamic LCA approach for the freshwater ecotoxicity impact of metals and application to a case study regarding zinc fertilization. *Int. J. Life Cycle Assess.* 19, 1745–1754. <https://doi.org/10.1007/s11367-014-0779-1>
- Lenton, T.M., Held, H., Kriegler, E., Hall, J.W., Lucht, W., Rahmstorf, S., Joachim, H., 2008. Tipping elements in the Earth ’ s climate system. *PNAS* 105. <https://doi.org/10.1073/pnas.0705414105>
- Lenzen, M., Dey, C.J., Murray, S.A., 2006. Historical accountability and cumulative impacts : the treatment of time in corporate sustainability reporting. *Ecol. Econ.* 51, 237–250. <https://doi.org/10.1016/j.ecolecon.2004.06.008>
- Leturcq, P., 2014. Wood preservation (carbon sequestration) or wood burning (fossil-fuel substitution), which is better for mitigating climate change? *Ann. For. Sci.* 71. <https://doi.org/10.1007/s13595-013-0269-9>
- Levasseur, A., Bahn, O., Beloin-Saint-Pierre, D., Marinova, M., Vaillancourt, K., 2017. Assessing butanol from integrated forest biorefinery: A combined techno-economic and life cycle approach. *Appl. Energy* 1–13. <https://doi.org/10.1016/j.apenergy.2017.04.040>
- Levasseur, A., Brandão, M., Lesage, P., Margni, M., Pennington, D., Clift, R., 2012a. Valuing temporary carbon storage. *Nat. Clim. Chang.* 2, 1–3. <https://doi.org/10.1038/nclimate1335>
- Levasseur, A., Cavalett, O., Fuglestvedt, J.S., Gasser, T., Johansson, D.J.A., Jørgensen, S. V., Rauegi, M., Reisinger, A., Schivley, G., Strømman, A., Tanaka, K., Cherubini, F., 2016. Enhancing life cycle impact assessment from climate science: Review of recent findings and recommendations for application to LCA. *Ecol. Indic.* 71, 163–174. <https://doi.org/10.1016/j.ecolind.2016.06.049>
- Levasseur, A., Lesage, P., Margni, M., Brandão, M., Samson, R., 2012b. Assessing temporary carbon sequestration and storage projects through land use, land-use change and forestry: comparison of dynamic life cycle assessment with ton-year approaches. *Clim. Change*. <https://doi.org/10.1007/s10584-012-0473-x>
- Levasseur, A., Lesage, P., Margni, M., Deschênes, L., Samson, R., 2010a. Considering time in LCA: Dynamic LCA and its application to global warming impact assessments. *Environ. Sci. Technol.* 44, 3169–3174. <https://doi.org/10.1021/es9030003>
- Levasseur, A., Lesage, P., Margni, M., Samson, R., 2012c. Biogenic Carbon and Temporary Storage Addressed with Dynamic Life Cycle Assessment. *J. Ind. Ecol.* 17, 117–128. <https://doi.org/10.1111/j.1530-9290.2012.00503.x>
- Levasseur, A., Lesage, P., Margni, M., Samson, R., 2010b. Instruction Manual: New Generation Carbon Footprinting. CIRAIG 1–16.
- Li, C., Frolking, S., Frolking, T., 1992. A Model of Nitrous Oxide Evolution From Soil Driven by Rainfall Events. 1. Model Structure and Sensitivity. *J. Geophys. Res.* 97, 9759–9776. <https://doi.org/10.1029/92JD00509>
- Li, F.G.N., Trutnevyte, E., 2017. Investment appraisal of cost-optimal and near-optimal pathways for the UK electricity sector transition to 2050. *Appl. Energy* 189, 89–109. <https://doi.org/10.1016/j.apenergy.2016.12.047>
- Liao, W., Werf, H.M.G. Van Der, Salmon-monviola, J., 2015. Improved Environmental Life Cycle Assessment of Crop Production at the Catchment Scale via a Process-Based Nitrogen Simulation

- Model 10790–10796. <https://doi.org/10.1021/acs.est.5b01347>
- Lindeijer, E., Müller-Wenk, R., Bengt, S., 2002. Impact Assessment of Resources and Land Use, in: de Haes, H.A.U., Finnveden, G., Goedkoop, M., Hauschild, Michael, Hertwich, E.G., Hofstetter, P., Jolliet, O., Klöpffer, W., Krewitt, W., Lindeijer, E., Müller-Wenk, R., Olsen, S.I., Pennington, D.W., Potting, J., Bengt, S. (Eds.), *Life-Cycle Impact Assessment: Striving towards Best Practice*. Society of Environmental Toxicology and Chemistry (SETAC), pp. 11–64.
- Liu, W., Zhu, Q., Zhou, X., Peng, C., 2019. Comparative analyses of different biogenic CO₂ emission accounting systems in life cycle assessment. *Sci. Total Environ.* 652, 1456–1462. <https://doi.org/10.1016/j.scitotenv.2018.11.039>
- Loiseau, E., Junqua, G., Roux, P., Bellon-Maurel, V., 2012. Environmental assessment of a territory: an overview of existing tools and methods. *J. Environ. Manage.* 112, 213–25. <https://doi.org/10.1016/j.jenvman.2012.07.024>
- Lopion, P., Markewitz, P., Robinius, M., Stolten, D., 2018. A review of current challenges and trends in energy systems modeling. *Renew. Sustain. Energy Rev.* 96, 156–166. <https://doi.org/10.1016/j.rser.2018.07.045>
- Loulou, R., Goldstein, G., Kanudia, A., Lettila, A., Remme, U., 2016. Documentation for the TIMES Model Part I. Energy Technology Systems Analysis Programme.
- Luo, Y., Ahlström, A., Allison, S.D., Batjes, N.H., Brovkin, V., Carvalhais, N., Chappell, A., Ciais, P., Davidson, E.A., Finzi, A., Georgiou, K., Guenet, B., Hararuk, O., Harden, J.W., He, Y., Hopkins, F., Jiang, L., Koven, C., Jackson, R.B., Jones, C.D., Lara, M.J., Liang, J., McGuire, A.D., Parton, W., Peng, C., Randerson, J.T., Salazar, A., Sierra, C.A., Smith, M.J., Tian, H., Todd-brown, K.E.O., Torn, M., Groenigen, K.J., Wang, Y.P., West, T.O., Wei, Y., Wieder, W.R., Xia, J., Xu, Xia, Xu, Xiaofeng, Zhou, T., 2016. Toward more realistic projections of soil carbon dynamics by Earth system models. *Global Biogeochem. Cycles* 40–56. <https://doi.org/10.1002/2015GB005239>.Received
- Luo, Y., White, L.W., Canadell, J.G., DeLucia, E.H., Ellsworth, D.S., Finzi, A., Lichter, J., Schlesinger, W.H., 2003. Sustainability of terrestrial carbon sequestration: A case study in Duke Forest with inversion approach. *Global Biogeochem. Cycles* 17, 1–13. <https://doi.org/10.1029/2002gb001923>
- Lützow, M. V., Kögel-Knabner, I., Ekschmitt, K., Matzner, E., Guggenberger, G., Marschner, B., Flessa, H., 2006. Stabilization of organic matter in temperate soils: Mechanisms and their relevance under different soil conditions - A review. *Eur. J. Soil Sci.* 57, 426–445. <https://doi.org/10.1111/j.1365-2389.2006.00809.x>
- Macías, C.A.S., Orihuela, J.C.A., Abad, S.I., 2017. Estimation of above- - ground live biomass and carbon stocks in different plant formations and in the soil of dry forests of the Ecuadorian coast 1–7. <https://doi.org/10.1002/fes3.115>
- Manneh, R., Margni, M., Desche, L., 2012. Evaluating the Relevance of Seasonal Differentiation of Human Health Intake Fractions in Life Cycle Assessment. *Integr. Environ. Assess. Manag.* 8, 749–759. <https://doi.org/10.1002/ieam.1308>
- Marcelis, L.F.M., Heuvelink, E., 2007. Chapter 9: Concepts of modelling carbon allocation among plant organs, in: J. Vos, L.F.M. Marcelis, P.H.B. de Visser, P.C.S. and J.B.E. (eds. . (Ed.), *Functional- Structural Plant Modelling in Crop Production*. Springer, Plant Sciences Group, Wageningen University and Research Centre, Wageningen, The Netherlands, pp. 103–111.
- Marvuglia, A., Benetto, E., Rege, S., Jury, C., 2013. Modelling approaches for consequential life-cycle assessment (C-LCA) of bioenergy: Critical review and proposed framework for biogas

- production. *Renew. Sustain. Energy Rev.* 25, 768–781. <https://doi.org/10.1016/j.rser.2013.04.031>
- Matthews, R., Sokka, L., Soimakallio, S., Mortimer, N., Rix, J., Schelhaas, M., Jenkins, T., Hogan, G., Mackie, E., Morris, A., Randle, T., 2014. Review of literature on biogenic carbon and life cycle assessment of forest bioenergy. Farnham.
- Meersmans, J., Martin, M.P., Lacarce, E., Orton, T.G., Baets, S.D.E., Gourrat, M., Saby, N.P.A., Wetterlind, J., Bispo, A., Quine, T.A., Arrouays, D., 2013. Estimation of Soil Carbon Input in France: An Inverse Modelling Approach. *Pedosphere* 23, 422–436. [https://doi.org/10.1016/S1002-0160\(13\)60035-1](https://doi.org/10.1016/S1002-0160(13)60035-1)
- Mendes, M.R., Aramaki, T., Hanaki, K., 2004. Comparison of the environmental impact of incineration and landfilling in São Paulo City as determined by LCA. *Resour. Conserv. Recycl.* 41, 47–63. <https://doi.org/10.1016/j.resconrec.2003.08.003>
- Menten, F., Tchong-Ming, S., Lorne, D., Bouvart, F., 2015. Lessons from the use of a long-term energy model for consequential life cycle assessment: The BTL case. *Renew. Sustain. Energy Rev.* 43, 942–960. <https://doi.org/10.1016/j.rser.2014.11.072>
- Milà i Canals, L., Bauer, C., Depestele, J., Dubreuil, A., Knuchel, R.F., 2007a. Key Elements in a Framework for Land Use Impact Assessment Within LCA. *Int. J. Life Cycle Assess.* 12, 5–15. <https://doi.org/10.1065/lca2006.05.250>
- Milà i Canals, L., de Baan, L., 2015. Chapter 11: Land Use, in: Hauschild, M.Z., Huijbregts, M.A.J. (Eds.), *Life Cycle Impact Assessment, LCA Compendium – The Complete World of Life Cycle Assessment*. Springer Science+Business Media Dordrecht, pp. 197–222. <https://doi.org/10.1007/978-94-017-9744-3>
- Milà i Canals, L., Romanyà, J., Cowell, S.J., 2007b. Method for assessing impacts on life support functions (LSF) related to the use of “fertile land” in Life Cycle Assessment (LCA). *J. Clean. Prod.* 15, 1426–1440. <https://doi.org/10.1016/j.jclepro.2006.05.005>
- Miller, S.A., Moysey, S., Sharp, B., Alfaro, J., 2013. A Stochastic Approach to Model Dynamic Systems in Life Cycle Assessment. *J. Ind. Ecol.* 17, 352–362. <https://doi.org/10.1111/j.1530-9290.2012.00531.x>
- Minasny, B., Malone, B.P., McBratney, A.B., Angers, D.A., Arrouays, D., Chambers, A., Chaplot, V., Chen, Z.S., Cheng, K., Das, B.S., Field, D.J., Gimona, A., Hedley, C.B., Hong, S.Y., Mandal, B., Marchant, B.P., Martin, M., McConkey, B.G., Mulder, V.L., O'Rourke, S., Richer-de-Forges, A.C., Odeh, I., Padarian, J., Paustian, K., Pan, G., Poggio, L., Savin, I., Stolbovoy, V., Stockmann, U., Sulaeman, Y., Tsui, C.C., Vågen, T.G., van Wesemael, B., Winowiecki, L., 2017. Sequestration potentials under consideration of the plant-soil system has been linked to management practices (Lal 2004). Yet, it has been stated that the sequestration requires increases in added C to the soil over a defined period of time (Lal 2008). *Geoderma* 292, 59–86. <https://doi.org/10.1016/j.geoderma.2017.01.002>
- Mitchell, S.R., Harmon, M.E., O'Connell, K.E.B., 2012. Carbon debt and carbon sequestration parity in forest bioenergy production. *GCB Bioenergy* 4, 818–827. <https://doi.org/10.1111/j.1757-1707.2012.01173.x>
- Molina, J.A.E., 1996. Description of the model NCSOIL, in: Powlson, D.S., Smith, P., Smith, J.U. (Eds.), *Evaluation of Soil Organic Matter Models*. Springer-Verlag, Berlin Heidelberg, pp. 269–274. https://doi.org/10.1007/978-3-642-61094-3_21
- Morais, T., Teixeira, R., Domingos, T., 2016. Regionalization of agri-food Life Cycle Assessment: A review of studies in Portugal and recommendations for the future. *Int. J. Life Cycle Assess.* 875–884. <https://doi.org/10.1007/s11367-016-1055-3>

References

- Morais, T.G., Silva, C., Jebari, A., Álvaro-Fuentes, J., Domingos, T., Teixeira, R.F.M., 2018. A proposal for using process-based soil models for land use Life cycle impact assessment: Application to Alentejo, Portugal. *J. Clean. Prod.* 192, 864–876. <https://doi.org/10.1016/j.jclepro.2018.05.061>
- Morrison, R., 2018. Energy system modeling: Public transparency, scientific reproducibility, and open development. *Energy Strateg. Rev.* 20, 49–63. <https://doi.org/10.1016/j.esr.2017.12.010>
- Mosimann, J.E., 1970. Size Allometry: Size and Shape Variables with Characterizations of the Lognormal and Generalized Gamma Distributions. *J. Am. Stat. Assoc.* 65, 930–945. <https://doi.org/10.1080/01621459.1970.10481136>
- Moura Costa, P., Wilson, C., 2000. An equivalence factor between CO₂ avoided emissions and sequestration - Description and application in forestry. *Mitig. Adapt. Strateg. Glob. Chang.* 5, 51–60. <https://doi.org/10.1023/A:1009697625521>
- MTES, 2017. Chiffres clés du climat France et Monde, Ministère de la Transition écologique et solidaire. MTES Ministère de la transition écologique et solidaire. Paris.
- MTES, 2015. Stratégie Nationale Bas-Carbone. National Low-Carbon Strategy. Summary for decision-makers. Paris.
- Mueller, T., Jensen, L.S., Hansen, S., Nielsen, N.E., 1996. Simulating soil carbon and nitrogen dynamics with the soil-plant-atmosphere system model DAISY, in: Powlson, D.S., Smith, P., Smith, J.U. (Eds.), *Evaluation of Soil Organic Matter Models*. Springer-Verlag, Berlin Heidelberg, pp. 275–281. https://doi.org/10.1007/978-3-642-61094-3_22
- Müller-Wenk, R., Brandão, M., 2010. Climatic impact of land use in LCA — carbon transfers between vegetation / soil and air. *Int. J. Life Cycle Assess.* 15, 172–182. <https://doi.org/10.1007/s11367-009-0144-y>
- Muñoz, I., Schmidt, J.H., Brandão, M., Weidema, B.P., 2015. Rebuttal to ‘ Indirect land use change (iLUC) within life cycle assessment (LCA) – scientific robustness and consistency with international standards .’ *GCB Bioenergy* 565–566. <https://doi.org/10.1111/gcbb.12231>
- Mutel, C., 2017. Brightway: An open source framework for Life Cycle Assessment. *J. Open Source Softw.* 2, 236. <https://doi.org/10.21105/joss.00236>
- Mutel, C.L., Hellweg, S., 2009. Regionalized life cycle assessment: computational methodology and application to inventory databases. *Environ. Sci. Technol.* 43, 5797–803. <https://doi.org/10.1021/es803002j>
- Myhre, G., Shindell, D., Bréon, F.-M., Collins, W., Fuglestedt, J., Huang, J., Koch, D., Lamarque, J.-F., Lee, D., Mendoza, B., Nakajima, T., Robock, A., Stephens, G., Takemura, T., Zhang, H., 2013a. Chapter 8 Anthropogenic and Natural Radiative Forcing, in: Stocker, T.F., Qin, G.-K., Plattner, M., Tignor, S.K. Allen, J. Boschung, A. Nauels, Y. Xia, V.B. and P.M.M. (eds.). (Ed.), *In: Climate Change 2013: The Physical Science Basis. Contribution of Working Group I to the Fifth Assessment Report of the Intergovernmental Panel on Climate Change* [Stocker, T.F., D. Qin, G.-K. Plattner, M. Tignor, S.K. Allen, J. Boschung, A. Nauels, Y. Cambridge University Press, Cambridge, United Kingdom and New York, pp. 659–740. <https://doi.org/10.1017/CBO9781107415324.018>
- Myhre, G., Shindell, D., Bréon, F.-M.F.-M., Collins, W., Fuglestedt, J., Huang, J., Koch, D., Lamarque, J.-F.J.-F., Lee, D., Mendoza, B., Nakajima, T., Robock, A., Stephens, G., Takemura, T., Zhan, H., Zhang, H., 2013b. Anthropogenic and Natural Radiative Forcing Supplementary Material, in: Stocker, T.F., Qin, D., Plattner, G.-K., Tignor, M., Allen, S.K., Boschung, J., Nauels, A., Xia, Y., Bex, V., Mindgley, P.. (Eds.), *Climate Change 2013: The Physical Science*

- Basis. Contribution of Working Group I to the Fifth Assessment Report of the Intergovernmental Panel on Climate Change: The Physical Science Basis. Contribution of Working Group I to the Fifth Assessment Report Of. Cambridge University Press, Cambridge and New York, pp. 1–44. <https://doi.org/10.1017/CBO9781107415324.018>
- Negishi, K., Lebert, A., Almeida, D., Chevalier, J., Tiruta-, L., 2019. Evaluating climate change pathways through a building's lifecycle based on Dynamic Life Cycle Assessment. *Build. Environ.* 106377. <https://doi.org/10.1016/j.buildenv.2019.106377>
- Negishi, K., Tiruta-Barna, L., Schiopu, N., Lebert, A., Chevalier, J., 2018. An operational methodology for applying dynamic Life Cycle Assessment to buildings. *Build. Environ.* 144, 611–621. <https://doi.org/10.1016/j.buildenv.2018.09.005>
- Niero, M., Ingvordsen, C.H., Jørgensen, R.B., Hauschild, M.Z., 2015. How to manage uncertainty in future Life Cycle Assessment (LCA) scenarios addressing the effect of climate change in crop production. *J. Clean. Prod.* 107, 693–706. <https://doi.org/10.1016/j.jclepro.2015.05.061>
- Nitschelm, L., Aubin, J., Corson, M.S., Viaud, V., Walter, C., 2016. Spatial differentiation in Life Cycle Assessment LCA applied to an agricultural territory: current practices and method development. *J. Clean. Prod.* 112, 2472–2484. <https://doi.org/10.1016/j.jclepro.2015.09.138>
- Noori, M., Tatari, O., 2016. Development of an agent-based model for regional market penetration projections of electric vehicles in the United States. *Energy* 96, 215–230. <https://doi.org/https://doi.org/10.1016/j.energy.2015.12.018>
- Núñez, M., Antón, A., Muñoz, P., Rieradevall, J., 2013. Inclusion of soil erosion impacts in life cycle assessment on a global scale: application to energy crops in Spain. *Int. J. Life Cycle Assess.* 18, 755–767. <https://doi.org/10.1007/s11367-012-0525-5>
- Núñez, M., Civit, B., Muñoz, P., Arena, A.P., Rieradevall, J., Antón, A., 2010. Assessing potential desertification environmental impact in life cycle assessment. *Int. J. Life Cycle Assess.* 15, 67–78. <https://doi.org/10.1007/s11367-009-0126-0>
- Núñez, M., Pfister, S., Vargas, M., Antón, A., 2015. Spatial and temporal specific characterisation factors for water use impact assessment in Spain. *Int. J. Life Cycle Assess.* 20, 128–138. <https://doi.org/10.1007/s11367-014-0803-5>
- O'Hare M., Plevin, R.J., Martin, J.I., Jones, A.D., Kendall, A., Hopson, E., 2009. Proper accounting for time increases crop-based biofuels' greenhouse gas deficit versus petroleum. *Environ. Res. Lett.* 4, 1–7. <https://doi.org/10.1088/1748-9326/4/2/024001>
- Oberholzer, H.-R., Knuchel, R.F., Weisskopf, P., Gaillard, G., 2012. A novel method for soil quality in life cycle assessment using several soil indicators. <https://doi.org/10.1007/s13593-011-0072-7>
- Odegard, I., Croezen, H., Bergsma, G., 2012. *Cascading of Biomass: 13 Solutions for a Sustainable Bio-based Economy: Making Better Choices for Use of Biomass Residues, By-products and Wastes.* Delft.
- Oertel, C., Matschullat, J., Zurba, K., Zimmermann, F., Erasmi, S., 2016. Greenhouse gas emissions from soils—A review. *Chemie der Erde - Geochemistry* 76, 327–352. <https://doi.org/10.1016/j.chemer.2016.04.002>
- Owens, J.W., 1997a. Life-Cycle Assessment Constraints: Constraints on Moving from Inventory to to Impact Assessment. *J. Ind. Ecol.*
- Owens, J.W., 1997b. Life-cycle assessment constraints: Constraints on moving from inventory to impact assessment. *J. Ind. Ecol.* 1, 37–49. <https://doi.org/10.1162/jiec.1997.1.1.37>

References

- Paine, C.E.T., Marthews, T.R., Vogt, D.R., Purves, D., Rees, M., Hector, A., Turnbull, L.A., 2012. How to fit nonlinear plant growth models and calculate growth rates: An update for ecologists. *Methods Ecol. Evol.* 3, 245–256. <https://doi.org/10.1111/j.2041-210X.2011.00155.x>
- Pandey, D., Agrawal, M., Pandey, J.S., 2011. Carbon footprint: Current methods of estimation. *Environ. Monit. Assess.* 178, 135–160. <https://doi.org/10.1007/s10661-010-1678-y>
- Parton, W.J., 1996. The CENTURY model, in: Powlson., D.S., Smith, P., Smith, J.U. (Eds.), *Evaluation of Soil Organic Matter Models*. Springer-Verlag, Berlin Heidelberg, pp. 283–291. https://doi.org/10.1007/978-3-642-61094-3_23
- Patouillard, L., Bulle, C., Querleu, C., Maxime, D., Osset, P., Margni, M., 2018. Critical review and practical recommendations to integrate the spatial dimension into life cycle assessment. *J. Clean. Prod.* 177, 398–412. <https://doi.org/10.1016/j.jclepro.2017.12.192>
- Pauliuk, S., Sjöstrand, K., Müller, D.B., 2013. Transforming the Norwegian dwelling stock to reach the 2 degrees celsius climate target: Combining material flow analysis and life cycle assessment techniques. *J. Ind. Ecol.* 17, 542–554. <https://doi.org/10.1111/j.1530-9290.2012.00571.x>
- Pawelzik, P., Carus, M., Hotchkiss, J., Narayan, R., Selke, S., Wellisch, M., Weiss, M., 2013. Author's personal copy Resources, Conservation and Recycling Critical aspects in the life cycle assessment (LCA) of bio-based materials – Reviewing methodologies and deriving recommendations. *Resour. Conserv. Recycl.* 73, 211–228. <https://doi.org/http://dx.doi.org/10.1016/j.resconrec.2013.02.006>
- Pawelzik, P., Carus, M., Hotchkiss, J., Narayan, R., Selke, S., Wellisch, M., Weiss, M., Wicke, B., Patel, M.K., 2013. Critical aspects in the life cycle assessment (LCA) of bio-based materials - Reviewing methodologies and deriving recommendations. *Resour. Conserv. Recycl.* 73, 211–228. <https://doi.org/10.1016/j.resconrec.2013.02.006>
- Payen, S., Basset-Mens, C., Colin, F., Roignant, P., 2018. Inventory of field water flows for agri-food LCA: critical review and recommendations of modelling options. *Int. J. Life Cycle Assess.* 1–20. <https://doi.org/10.1007/s11367-017-1353-4>
- Pehnt, M., 2006. Dynamic life cycle assessment (LCA) of renewable energy technologies. *Renew. Energy* 31, 55–71. <https://doi.org/10.1016/j.renene.2005.03.002>
- Pelletier, N., Allacker, K., Pant, R., Manfredi, S., 2013. The European Commission Organisation Environmental Footprint method: comparison with other methods, and rationales for key requirements. *Int. J. Life Cycle Assess.* 19, 387–404. <https://doi.org/10.1007/s11367-013-0609-x>
- Pelletier, N., Ardente, F., Brandão, M., De Camillis, C., Pennington, D., 2015. Rationales for and limitations of preferred solutions for multi-functionality problems in LCA: is increased consistency possible? *Int. J. Life Cycle Assess.* 20, 74–86. <https://doi.org/10.1007/s11367-014-0812-4>
- Peñaloza, D., Erlandsson, M., Falk, A., 2016. Exploring the climate impact effects of increased use of bio-based materials in buildings. *Constr. Build. Mater.* 125, 219–226. <https://doi.org/10.1016/j.conbuildmat.2016.08.041>
- Peñaloza, D., Røyne, F., Sandin, G., Svanström, M., Erlandsson, M., 2018. The influence of system boundaries and baseline in climate impact assessment of forest products. *Int. J. Life Cycle Assess.* <https://doi.org/10.1007/s11367-018-1495-z>
- Petersen, B.M., Knudsen, M.T., Hermansen, J.E., Halberg, N., 2013. An approach to include soil carbon changes in life cycle assessments. *J. Clean. Prod.* 52, 217–224. <https://doi.org/10.1016/j.jclepro.2013.03.007>

- Pfenninger, S., Hawkes, A., Keirstead, J., 2014. Energy systems modeling for twenty-first century energy challenges. *Renew. Sustain. Energy Rev.* 33, 74–86. <https://doi.org/10.1016/j.rser.2014.02.003>
- Pienaar, L.V., Turnbull, K.J., 1973. The Chapman-Richards generalization of Von Bertalanffy's growth model for basal area growth and yield in even-aged stands. *For. Sci.* 19, 2–22. <https://doi.org/https://doi.org/10.1093/forestscience/19.1.2>
- Pingoud, K., Ekholm, T., Savolainen, I., 2012. Global warming potential factors and warming payback time as climate indicators of forest biomass use. *Mitig. Adapt. Strateg. Glob. Chang.* 17, 369–386. <https://doi.org/10.1007/s11027-011-9331-9>
- Pingoud, K., Ekholm, T., Soimakallio, S., Helin, T., 2016. Carbon balance indicator for forest bioenergy scenarios. *GCB Bioenergy* 8, 171–182. <https://doi.org/10.1111/gcbb.12253>
- Pinsonnault, A., Lesage, P., Levasseur, A., Samson, R., 2014. Temporal differentiation of background systems in LCA: relevance of adding temporal information in LCI databases. *Int. J. Life Cycle Assess.* 19, 1843–1853. <https://doi.org/10.1007/s11367-014-0783-5>
- Plattner, G., Stocker, T., Midgley, P., Tignor, M., 2009. IPCC Expert Meeting on the Science of Alternative Metrics: Meeting Report, Science.
- Pommerening, A., 2017. Arne Pommerening's Webblog on Forest Biometrics [WWW Document]. Swedish Univ. Agric. Sci. URL <https://blogg.slu.se/forest-biometrics/2017/03/11/the-chapman-richards-growth-function/> (accessed 11.15.17).
- Pommerening, A., Muszta, A., 2016. Relative plant growth revisited: Towards a mathematical standardisation of separate approaches. *Ecol. Modell.* 320, 383–392. <https://doi.org/10.1016/j.ecolmodel.2015.10.015>
- Porsö, C., Hammar, T., Nilsson, D., Hansson, P.A., 2018. Time-Dependent Climate Impact and Energy Efficiency of Internationally Traded Non-torrefied and Torrefied Wood Pellets from Logging Residues. *Bioenergy Res.* 11, 139–151. <https://doi.org/10.1007/s12155-017-9884-x>
- Pretzsch, H., 2009. Forest Dynamics, Growth and Yield- From Measurement to Model, Forest Research. Springer-Verlag, Berlin Heidelberg. <https://doi.org/10.1007/978-3-540-88307-4>
- Pretzsch, H., Biber, P., Schütze, G., Uhl, E., Rötzer, T., 2014. Forest stand growth dynamics in Central Europe have accelerated since 1870. *Nat. Commun.* 5, 1–10. <https://doi.org/10.1038/ncomms5967>
- Rabl, A., Benoist, A., Dron, D., Peuportier, B., Spadaro, J. V., Zoughaib, A., 2007. How to account for CO2 emissions from biomass in an LCA. *Int. J. Life Cycle Assess.* 12, 281–281. <https://doi.org/10.1007/s11367-007-0347-z>
- Rathmann, R., Szklo, A., Schaeffer, R., 2010. Land use competition for production of food and liquid biofuels: An analysis of the arguments in the current debate. *Renew. Energy* 35, 14–22. <https://doi.org/10.1016/j.renene.2009.02.025>
- Reap, J., Roman, F., Duncan, S., Bras, B., 2008a. A survey of unresolved problems in life cycle assessment. Part 2: Impact assessment and interpretation. *Int. J. Life Cycle Assess.* 13, 374–388. <https://doi.org/10.1007/s11367-008-0009-9>
- Reap, J., Roman, F., Duncan, S., Bras, B., 2008b. A survey of unresolved problems in life cycle assessment. Part 1: Goal and scope and inventory analysis. *Int. J. Life Cycle Assess.* 13, 290–300. <https://doi.org/10.1007/s11367-008-0008-x>
- Reap, J., Roman, F., Duncan, S., Bras, B., 2008c. Part 2 : impact assessment and interpretation. *Int J*

- Life Cycle Assess 374–388. <https://doi.org/10.1007/s11367-008-0009-9>
- Rebitzer, G., Ekvall, T., Frischknecht, R., Hunkeler, D., Norris, G., Rydberg, T., Schmidt, W.-P., Suh, S., Weidema, B.P., Pennington, D.W., 2004. Life cycle assessment part 1: framework, goal and scope definition, inventory analysis, and applications. *Environ. Int.* 30, 701–20. <https://doi.org/10.1016/j.envint.2003.11.005>
- Rees, M., Osborne, C.P., Woodward, F.I., Hulme, S.P., Turnbull, L.A., Taylor, S.H., 2010. Partitioning the components of relative growth rate: How important is plant size variation? *Am. Nat.* 176. <https://doi.org/10.1086/657037>
- Rehbein, K., Sandhage-hofmann, A., Amelung, W., 2015. Soil carbon accrual in particle-size fractions under *Miscanthus x. giganteus* cultivation. *Biomass and Bioenergy* 78, 80–91. <https://doi.org/10.1016/j.biombioe.2015.04.006>
- Repo, A., Tuovinen, J.P., Liski, J., 2015. Can we produce carbon and climate neutral forest bioenergy? *GCB Bioenergy* 7, 253–262. <https://doi.org/10.1111/gcbb.12134>
- Rockström, J., Steffen, W., Noone, K., Persson, Å., Chapin III, F.S., Lambin, E.F., Lenton, T.M., Scheffer, M., Folke, C., Schellnhuber, H., Nykvist, B., de Wit, C.A., Hughes, T., van der Leeuw, S., Rodhe, H., Sörlin, S., Snyder, P.K., Costanza, R., Al., E., 2009. Planetary Boundaries: Exploring the Safe Operating Space for Humanity. *Ecol. Soc.* 14, 32. <https://doi.org/10.1038/461472a>
- Rosenbaum, R.K., Bachmann, T.M., Gold, L.S., Huijbregts, M.A.J., Jolliet, O., Juraske, R., Koehler, A., Larsen, H.F., MacLeod, M., Margni, M., McKone, T.E., Payet, J., Schuhmacher, M., van de Meent, D., Hauschild, M.Z., 2008. USEtox—the UNEP-SETAC toxicity model: recommended characterisation factors for human toxicity and freshwater ecotoxicity in life cycle impact assessment. *Int. J. Life Cycle Assess.* 13, 532–546. <https://doi.org/10.1007/s11367-008-0038-4>
- Rosenbaum, R.K., Hauschild, M.Z., Boulay, A.-M., Fantke, P., Laurent, A., Núñez, M., Vieira, M., 2018. Chapter 10. Life Cycle Impact Assessment, in: Hauschild, M.Z., Rosenbaum, R.K., Olsen, S.I. (Eds.), *Life Cycle Assessment: Theory and Practice*. Springer, pp. 167–270. <https://doi.org/10.1007/978-3-319-56475-3>
- Saad, R., Margni, M., Koellner, T., Wittstock, B., Deschênes, L., 2011. Assessment of land use impacts on soil ecological functions: development of spatially differentiated characterization factors within a Canadian context 198–211. <https://doi.org/10.1007/s11367-011-0258-x>
- Sala, S., Farioli, F., Zamagni, A., 2012a. Progress in sustainability science: lessons learnt from current methodologies for sustainability assessment: Part 1. *Int. J. Life Cycle Assess.* 18, 1653–1672. <https://doi.org/10.1007/s11367-012-0508-6>
- Sala, S., Pant, R., Hauschild, M., Pennington, D., 2012b. Research needs and challenges from science to decision support. Lesson learnt from the development of the international reference life cycle data system (ILCD) recommendations for life cycle impact assessment. *Sustainability* 4, 1412–1425. <https://doi.org/10.3390/su4071412>
- Scarlat, N., Dallemand, J., Monforti-ferrario, F., Banja, M., 2015. Renewable energy policy framework and bioenergy contribution in the European Union – An overview from National Renewable Energy Action Plans and Progress Reports. *Renew. Sustain. Energy Rev.* 51, 969–985. <https://doi.org/10.1016/j.rser.2015.06.062>
- Schlamadinger, B., Apps, M., Bohling, F., Gustavsson, L., Jungmeier, G., Marland, G., Pingoud, K., Savolainen, I., 1997. Towards a standard methodology for greenhouse gas balances of bioenergy systems in comparison with fossil energy systems. *Biomass and Bioenergy* 13, 359–375. [https://doi.org/SO961-9534\(97\)10032-O](https://doi.org/SO961-9534(97)10032-O)

- Schlamadinger, B., Marland, G., 1996. The role of forest and bioenergy strategies in the global carbon cycle. *Biomass and Bioenergy* 10, 275–300. [https://doi.org/10.1016/0961-9534\(95\)00113-1](https://doi.org/10.1016/0961-9534(95)00113-1)
- Schmidinger, K., Stehfest, E., 2012. Including CO₂ implications of land occupation in LCAs — method and example for livestock products. *Int. J. Life Cycle Assess.* 17, 962–972. <https://doi.org/10.1007/s11367-012-0434-7>
- Schmidt, J.H., 2010. Comparative life cycle assessment of rapeseed oil and palm oil. *Int. J. Life Cycle Assess.* 15, 183–197. <https://doi.org/10.1007/s11367-009-0142-0>
- Schmidt, J.H., Weidema, B.P., Brandão, M., 2015. A framework for modelling indirect land use changes in Life Cycle Assessment. *J. Clean. Prod.* 99, 230–238. <https://doi.org/10.1016/j.jclepro.2015.03.013>
- Schmidt, M.W.I., Torn, M.S., Abiven, S., Dittmar, T., Guggenberger, G., Janssens, I.A., Kleber, M., Kögel-Knabner, I., Lehmann, J., Manning, D.A.C., Nannipieri, P., Rasse, D.P., Weiner, S., Trumbore, S.E., 2011. Persistence of soil organic matter as an ecosystem property. *Nature* 478, 49–56. <https://doi.org/10.1038/nature10386>
- Schrijvers, D.L., Loubet, P., Sonnemann, G., 2016. Developing a systematic framework for consistent allocation in LCA. *Int. J. Life Cycle Assess.* 1–18. <https://doi.org/10.1007/s11367-016-1063-3>
- Schulze, E.-D., Körner, C., Law, B.E., H. Haberl, Luysaert, S., 2012. Large-scale bioenergy from additional harvest of forest biomass is neither sustainable nor greenhouse gas neutral. *GCB Bioenergy* 611–616. <https://doi.org/10.1111/j.1757-1707.2012.01169.x>
- Schweinle, J., Rödl, A., Börjesson, P., Neary, D.G., Langeveld, J.W. a., Berndes, G., Cowie, A., Ahlgren, S., Margni, M., Gaudreault, C., Verschuyf, J., Wigley, T.B., Vice, K., Titus, B., 2015. Assessing the environmental performance of biomass supply chains - Methods, Results, Challenges and Limitations 123. <https://doi.org/IEA Bioenergy Task 43, Report 2015:TR01>
- SDES, 2019. Chiffres clés du climat – France, Europe et Monde. Le service de la donnée et des études statistiques (SDES)- Ministère de la Transition Ecologique et Solidaire (MTES), Paris, France.
- Searchinger, T., Heimlich, R., Houghton, R.A., Dong, F., Elobeid, A., Fabiosa, J., Tokgoz, S., Hayes, D., Yu, T., 2008. Use of U.S. Croplands for Biofuels Increases Greenhouse Gases Through Emissions from Land-Use Change. *Science* (80-.). 423, 1238–1240. <https://doi.org/10.1126/science.1151861>
- Searchinger, T.D., Hamburg, S.P., Melillo, J., Chameides, W., Havlik, P., Kammen, D.M., Likens, G.E., Lubowski, R.N., Michael Obersteiner, M.O., Robertson, G.P., Schlesinger, W.H., Tilman, G.D., 2009. Fixing a critical climate accounting error. *Sci.* 326(5952)527–528 326, 527–528. <https://doi.org/10.1126/science.1178797>
- Shah, V.P., Ries, R.J., 2009. A characterization model with spatial and temporal resolution for life cycle impact assessment of photochemical precursors in the united States. *Int. J. Life Cycle Assess.* 14, 313–327. <https://doi.org/10.1007/s11367-009-0084-6>
- Shibu, M.E., Leffelaar, P.A., Van Keulen, H., Aggarwal, P.K., 2006. Quantitative description of soil organic matter dynamics-A review of approaches with reference to rice-based cropping systems. *Geoderma* 137, 1–18. <https://doi.org/10.1016/j.geoderma.2006.08.008>
- Shimako, A.H., Tiruta-Barna, L., Ahmadi, A., 2017. Operational integration of time dependent toxicity impact category in dynamic LCA. *Sci. Total Environ.* 599–600, 806–819. <https://doi.org/10.1016/j.scitotenv.2017.04.211>
- Shimako, A.H., Tiruta-Barna, L., Pigné, Y., Benetto, E., Navarrete Gutiérrez, T., Guiraud, P., Ahmadi, A., 2016. Environmental assessment of bioenergy production from microalgae based systems. *J.*

- Clean. Prod. 139, 51–60. <https://doi.org/10.1016/j.jclepro.2016.08.003>
- Shine, K.P., 2009. The global warming potential — the need for an interdisciplinary retrieval An editorial comment. *Clim. Chang.* 96, 467–472. <https://doi.org/10.1007/s10584-009-9647-6>
- Shine, K.P., Berntsen, T.K., Fuglestvedt, J.S., Skeie, R.B., Stuber, N., 2007. Comparing the climate effect of emissions of short- and long-lived climate agents. *Philos. Trans. A. Math. Phys. Eng. Sci.* 365, 1903–1914. <https://doi.org/10.1098/rsta.2007.2050>
- Shine, K.P., Fuglestvedt, J.S., Hailemariam, K., Stuber, N., 2005. Alternatives to the Global Warming Potential for comparing climate impacts of emissions of greenhouse gases. *Clim. Change* 68, 281–302. <https://doi.org/10.1007/s10584-005-1146-9>
- Sleeswijk, A.W., van Oers, L.F.C.M., Guinée, J.B., Struijs, J., Huijbregts, M.A.J., 2008. Normalisation in product life cycle assessment: An LCA of the global and European economic systems in the year 2000. *Sci. Total Environ.* 390, 227–240. <https://doi.org/10.1016/j.scitotenv.2007.09.040>
- Smith Cooper, J., Kahn, E., 2012. Commentary on issues in data quality analysis in life cycle assessment. *Int. J. Life Cycle Assess.* 17, 499–503. <https://doi.org/10.1007/s11367-011-0371-x>
- Soimakallio, S., Brandão, M., Ekvall, T., Cowie, A., Finnveden, G., Erlandsson, M., Koponen, K., Karlsson, P., 2016. On the validity of natural regeneration in determination of land-use baseline 448–450. <https://doi.org/10.1007/s11367-016-1032-x>
- Sonnemann, G., Gemechu, E., Sala, S., Schau, E., Allacker, K., Pant, R., Adibi, N., Valdivia, S., 2017. Chapter 18. Life Cycle Thinking and the use of LCA in policies around the world, in: Hauschild, M.Z., Rosenbaum, R.K., Olsen, S.I. (Eds.), *Life Cycle Assessment: Theory and Practice*. Springer, pp. 1–1216. <https://doi.org/10.1007/978-3-319-56475-3>
- Sonnemann, G., Valdivia, S., 2013. Chapter 4. The UNEP/SETAC Life Cycle Initiative, in: Klöpffer, W. (Ed.), *Background and Future Prospects in Life Cycle Assessment, LCA Compendium – The Complete World of Life Cycle Assessment*. Springer Science+Business Media Dordrecht, pp. 1–36. <https://doi.org/10.1017/CBO9781107415324.004>
- Soode, E., Weber-Blaschke, G., Richter, K., 2013. Comparison of product carbon footprint standards with a case study on poinsettia (*Euphorbia pulcherrima*). *Int. J. Life Cycle Assess.* 18, 1280–1290. <https://doi.org/10.1007/s11367-013-0575-3>
- Spielmann, M., Scholz, R.W., Tietje, O., Haan, P. de, 2005. Scenario Modelling in Prospective LCA of Transport Systems. *Int. J. Life Cycle Assess.* 10, 325–335. <https://doi.org/10.1065/lca2004.10.188>
- Stockmann, U., Adams, M.A., Crawford, J.W., Field, D.J., Henakaarchchi, N., Jenkins, M., Minasny, B., McBratney, A.B., Courcelles, V. de R. de, Singh, K., Wheeler, I., Abbott, L., Angers, D.A., Baldock, J., Bird, M., Brookes, P.C., Chenu, C., Jastrow, J.D., Lal, R., Lehmann, J., O'Donnell, A.G., Parton, W.J., Whitehead, D., Zimmermann, M., 2013. The knowns, known unknowns and unknowns of sequestration of soil organic carbon. *Agric. Ecosyst. Environ.* 164, 80–99. <https://doi.org/10.1016/j.agee.2012.10.001>
- Styles, D., Jones, M.B., 2007. Energy crops in Ireland: Quantifying the potential life-cycle greenhouse gas reductions of energy-crop electricity. *Biomass and Bioenergy* 31, 759–772. <https://doi.org/10.1016/j.biombioe.2007.05.003>
- Su, S., Li, X., Zhu, Y., 2019. Dynamic assessment elements and their prospective solutions in dynamic life cycle assessment of buildings. *Build. Environ.* 158, 248–259. <https://doi.org/10.1016/j.buildenv.2019.05.008>

- Subramanian, A.S.R., Gundersen, T., Adams, T.A., 2018. Modeling and simulation of energy systems: A review. *Processes* 6. <https://doi.org/10.3390/pr6120238>
- Tackenberg, O., 2007. A new method for non-destructive measurement of biomass, growth rates, vertical biomass distribution and dry matter content based on digital image analysis. *Ann. Bot.* 99, 777–783. <https://doi.org/10.1093/aob/mcm009>
- Tarnocai, C., Canadell, J.G., Schuur, E.A.G., Kuhry, P., Mazhitova, G., Zimov, S., 2009. Soil organic carbon pools in the northern circumpolar permafrost region 23, 1–11. <https://doi.org/10.1029/2008GB003327>
- Thrän, D., Witt, J., Schaubach, K., Kiel, J., Carbo, M., Maier, J., Ndibe, C., Koppejan, J., Alakangas, E., Majer, S., Schipfer, F., 2015. Moving torrefaction towards market introduction e Technical improvements and economic-environmental assessment along the overall torrefaction supply chain through the SECTOR project. *Biomass and Bioenergy* 89, 184–200. <https://doi.org/10.1016/j.biombioe.2016.03.004>
- Tiruta-Barna, L., Pigné, Y., Navarrete Gutiérrez, T., Benetto, E., 2016. Framework and computational tool for the consideration of time dependency in Life Cycle Inventory: Proof of concept. *J. Clean. Prod.* <https://doi.org/10.1016/j.jclepro.2015.12.049>
- Tol, R.S.J., Berntsen, T.K., O'Neill, B.C., Fuglestvedt, J.S., Shine, K.P., 2012. A unifying framework for metrics for aggregating the climate effect of different emissions. *Environ. Res. Lett.* 7. <https://doi.org/10.1088/1748-9326/7/4/044006>
- Trutnevyte, E., 2016. Does cost optimization approximate the real-world energy transition? *Energy* 106, 182–193. <https://doi.org/10.1016/j.energy.2016.03.038>
- Tyszler, M., Kramer, G., Blonk, H., 2014. Comparing apples with oranges: On the functional equivalence of food products for comparative LCAs. *Int. J. Life Cycle Assess.* 19, 1482–1487. <https://doi.org/10.1007/s11367-014-0762-x>
- Udo de Haes, H., Finnveden, G., Goedkoop, M., Herwich, E., Hofstetter, P., Klöpffer, W., Krewitt, W., Lindeijer, E., 2002. *Life Cycle Impact Assessment: Striving towards best practice*, SETAC Press. SETAC Press.
- UN Environment/SETAC, 2006. *Background Report for a UNEP Guide to Life Cycle Management - A bridge to sustainable products*.
- UNEP/SETAC, 2016. *Pre-publication preview: Global Guidance for Life Cycle Impact Assessment Indicators: Volume 1*. Paris.
- UNEP/SETAC, 2005. *Life Cycle Approaches - The road from analysis to practice*, United Nations Publications. Paris.
- UNEP, 2011. *Global Guidance Principles for Life Cycle Assessment Databases - A basis for Greener Processes and Products*. UNEP Setac Life Cycle Initiative.
- UNFCCC, 2019. *Clean development mechanism projects of the United Nations Framework Convention on Climate Change [WWW Document]*. United Nations Framew. Conv. Clim. Chang. URL <https://cdm.unfccc.int/Projects/index.html> (accessed 1.22.19).
- UNFCCC, 2018. *Climate Get the Big Picture - A guide to the UNFCCC and its processes [WWW Document]*. United Nations Conv. Clim. Chang. URL <https://bigpicture.unfccc.int/> (accessed 1.1.18).
- UNFCCC, 2014. *A Summary of the Kyoto Protocol [WWW Document]*. United Nations Framew. Conv. Clim. Chang. URL http://unfccc.int/kyoto_protocol/background/items/2879.php (accessed

References

2.2.18).

- UNFCCC, 2008. Kyoto Protocol Reference Manual: On accounting of emissions and assigned amount.
- Van Zelm, R., Huijbregts, M.A.J., Van Jaarseld, H.A., Reinds, J.G., De Zwart, D., Struijs, J., Van de Meent, D., 2007. Time Horizon Dependent Characterization Factors for Acidification in Life-Cycle Assessment Based on Forest Plant Species Occurrence in Europe. *Environ. Sci. Technol.* 41, 922–927.
- Vassilev, S. V., Baxter, D., Andersen, L.K., Vassileva, C.G., 2010. An overview of the chemical composition of biomass. *Fuel* 89, 913–933. <https://doi.org/10.1016/j.fuel.2009.10.022>
- Vázquez-Rowe, I., Marvuglia, A., Rege, S., Benetto, E., 2014. Applying consequential LCA to support energy policy: Land use change effects of bioenergy production. *Sci. Total Environ.* 472, 78–89. <https://doi.org/10.1016/j.scitotenv.2013.10.097>
- Vázquez-Rowe, I., Rege, S., Marvuglia, A., Thénie, J., Haurie, A., Benetto, E., 2013. Application of three independent consequential LCA approaches to the agricultural sector in Luxembourg. *Int. J. Life Cycle Assess.* 18, 1593–1604. <https://doi.org/10.1007/s11367-013-0604-2>
- Vidal Legaz, B., Maia De Souza, D., Teixeira, R.F.M., Antón, A., Putman, B., Sala, S., 2016. Soil quality, properties, and functions in Life Cycle Assessment: an evaluation of models. *J. Clean. Prod.* 140, 1–14. <https://doi.org/10.1016/j.jclepro.2016.05.077>
- Vigon, B.W., Tolle, D.A., Cornaby, B.W., Latham, H.C., Le, B.I., Harrison, C.L., Boguski, T.L., Hunt, R.G., Sellers, J.D., 1993. Life-Cycle Assessment: Inventory Guidelines and Principles. EPA, Cincinnati.
- Viveros Santos, I., Bulle, C., Levasseur, A., Deschênes, L., 2018. Regionalized terrestrial ecotoxicity assessment of copper-based fungicides applied in viticulture. *Sustain.* 10. <https://doi.org/10.3390/su10072522>
- Vogtländer, J.G., Van Der Velden, N.M., Van Der Lugt, P., 2014. Carbon sequestration in LCA, a proposal for a new approach based on the global carbon cycle: Cases on wood and on bamboo. *Int. J. Life Cycle Assess.* 19, 13–23. <https://doi.org/10.1007/s11367-013-0629-6>
- Vrasdonk, E., Palme, U., Lennartsson, T., 2019. Reference situations for biodiversity in life cycle assessments: conceptual bridging between LCA and conservation biology. *Int. J. Life Cycle Assess.* 1631–1642. <https://doi.org/10.1007/s11367-019-01594-x>
- Walser, T., Demou, E., Lang, D.J., Hellweg, S., 2011. Prospective environmental life cycle assessment of nanosilver T-shirts. *Environ. Sci. Technol.* 45, 4570–4578. <https://doi.org/10.1021/es2001248>
- Weidema, B.P., 2000. Avoiding Co-Product Allocation in Life-Cycle Assessment. *J. Ind. Ecol.* 4, 11–33. <https://doi.org/10.1162/108819800300106366>
- Weidema, B.P., Pizzol, M., Schmidt, J., Thoma, G., 2018. Attributional or consequential Life Cycle Assessment: A matter of social responsibility. *J. Clean. Prod.* 174, 305–314. <https://doi.org/10.1016/j.jclepro.2017.10.340>
- Weidema, B.P., Schmidt, J.H., 2010. Avoiding Allocation in Life Cycle Assessment Revisited 14. <https://doi.org/10.1111/j.1530-9290.2010.00236.x>
- Wender, B.A., Foley, R.W., Hottle, T.A., Sadowski, J., Prado-Lopez, V., Eisenberg, D.A., Laurin, L., Seager, T.P., 2014. Anticipatory LCA for responsible research & innovation. *J. Responsible Innov.* 1, 200–207. <https://doi.org/https://doi.org/10.1080/23299460.2014.920121>

- Wiesmeier, M., Urbanski, L., Hobbey, E., Lang, B., Lützw, M. von, Marin-Spiotta, E., Wesemael, B. van, Rabot, E., Ließ, M., Garcia-Franco, N., Wollschläger, U., Vogel, H.-J., Kögel-Knabner, I., 2019. Soil organic carbon storage as a key function of soils - A review of drivers and indicators at various scales. *Geoderma* 333, 149–162. <https://doi.org/10.1016/j.geoderma.2018.07.026>
- Wiloso, E.I., Heijungs, R., Huppes, G., Fang, K., 2016. Effect of biogenic carbon inventory on the life cycle assessment of bioenergy: Challenges to the neutrality assumption. *J. Clean. Prod.* 125, 78–85. <https://doi.org/10.1016/j.jclepro.2016.03.096>
- Wise, M., Calvin, K., Thomson, A., Clarke, L., Bond-Lamberty, B., Sands, R., Smith, S.J., Janetos, A., Edmonds, J., 2009. Implications of limiting CO₂ concentrations for land use and energy. *Science* (80-.). 324, 1183–1186. <https://doi.org/10.1126/science.1168475>
- Wolf, M.-A., Chomkamsri, K., 2014. The “Integrated formula” for modelling recycling , energy recovery and reuse in LCA - White paper. White Pap.
- Wood, R., Hertwich, E.G., 2012. Economic modelling and indicators in life cycle sustainability assessment. *Int. J. Life Cycle Assess.* 18, 1710–1721. <https://doi.org/10.1007/s11367-012-0463-2>
- WRI/WBCSD, 2011. Product Life Cycle Accounting and Reporting Standard. World Resources Institute and World Business Council for Sustainable Development. [https://doi.org/ISBN 978-1-56973-773-6](https://doi.org/ISBN%20978-1-56973-773-6)
- Wu, X., Peng, B., Lin, B., 2017. A dynamic life cycle carbon emission assessment on green and non-green buildings in China. *Energy Build.* 149, 272–281. <https://doi.org/10.1016/j.enbuild.2017.05.041>
- Yang, Y., Suh, S., 2015. Marginal yield, technological advances, and emissions timing in corn ethanol’s carbon payback time. *Int. J. Life Cycle Assess.* 20, 226–232. <https://doi.org/10.1007/s11367-014-0827-x>
- Yuan, C., Wang, E., Zhai, Q., Yang, F., 2015. Temporal discounting in life cycle assessment: A critical review and theoretical framework. *Environ. Impact Assess. Rev.* 51, 23–31. <https://doi.org/10.1016/j.eiar.2015.01.001>
- Zamagni, A., Guinée, J., Heijungs, R., Masoni, P., Raggi, A., 2012. Lights and shadows in consequential LCA. *Int. J. Life Cycle Assess.* 17, 904–918. <https://doi.org/10.1007/s11367-012-0423-x>
- Zamagni, A., Pesonen, H.-L., Swarr, T., 2013. From LCA to Life Cycle Sustainability Assessment: concept, practice and future directions. *Int. J. Life Cycle Assess.* 18, 1637–1641. <https://doi.org/10.1007/s11367-013-0648-3>
- Zaman, A.U., 2010. Comparative study of municipal solid waste treatment technologies using life cycle assessment method. *Int. J. Environ. Sci. Technol.* 7, 225–234. <https://doi.org/10.1007/BF03326132>
- Zanchi, G., Pena, N., Bird, N., 2010. The upfront carbon debt of bioenergy, Joanneum Research. Graz.Austria.
- Zeide, B., 1993. Primary Unit of the Tree Crown. *Ecology* 74, 1598–1602. <https://doi.org/10.2307/1940088>
- Zetterberg, L., Chen, D., 2015. The time aspect of bioenergy - climate impacts of solid biofuels due to carbon dynamics. *GCB Bioenergy* 7, 785–796. <https://doi.org/10.1111/gcbb.12174>
- Zhao-gang, L., Feng-ri, L., 2003. The generalized Chapman-Richards function and applications to tree and stand growth. *J. For. Res.* 14, 19–26. <https://doi.org/10.1007/BF02856757>

References

Zilberman, D., Hochman, G., 2010. Indirect Land Use Change : A Second-best Solution to a First-class Problem, CUDARE Working Papers. AgBioForum. University of California, Berkeley Department of Agricultural & Resource Economics.

Appendices

Appendices

Appendix A: Paper 4 – Review paper on the time consideration in LCA

The version of the manuscript presented below dates of January 2020, as submitted to the Journal Science of the Total Environment. The current status is under review.

Objective	Conduct a detailed review of the state of the art of temporal consideration in LCA within the LCA phases and provide directions for further research.
Approach	Dynamic LCA applied to all relevant systems
Sector (product)	Cross-sectorial
Biomass	included
Referred to	Supplementary Material included in the submission

Temporal Considerations in Life Cycle Assessment: A Review

Didier Beloin-Saint-Pierre ^{1,*}, **Ariane Albers** ², **Arnaud Hélias** ³, **Ligia Tiruta-Barna** ⁴, **Peter Fantke** ⁵, **Annie Levasseur** ⁶, **Enrico Benetto** ⁷, **Anthony Benoist** ⁸, **Pierre Collet** ²

¹ Empa Materials Science and Technology, Lerchenfeldstrasse 5, CH-9014 St. Gallen, Switzerland

² IFP Energies Nouvelles, 1 et 4 Avenue de Bois-Préau, 92852 Rueil-Malmaison, France

³ ITAP, Irstea, Montpellier SupAgro, Univ Montpellier, ELSA Research Group, Montpellier, France

⁴ TBI, Université de Toulouse, CNRS, INRAE, INSA, Toulouse, France

⁵ Quantitative Sustainability Assessment, Department of Technology, Management and Economics, Technical University of Denmark, Kgs. Lyngby, Denmark

⁶ École de technologie supérieure, Construction Engineering Department, 1100 Notre-Dame West, Montréal, Québec, Canada

⁷ Environmental Sustainability Assessment and Circularity Unit, Department of Environmental Research and Innovation, Luxembourg Institute of Science and Technology, Esch/Alzette, Luxembourg

⁸ CIRAD, UPR BioWooEB, F-34398 Montpellier, France

* corresponding author

Abstract

Purpose In life cycle assessment (LCA), temporal considerations for modelling resource extractions, usage and emissions are usually lost during the life cycle inventory calculation, resulting in a “snapshot in time” of the potential impacts. However, disregarding temporal considerations has previously been underlined as an important source of uncertainty. A growing number of approaches and tools are recently developed, but their adoption and implementation by LCA practitioners are still uncommon, which raises concerns about the representativeness of current LCA results. Furthermore, it appears that a wide range of terms related to temporal considerations is used sometimes with different meanings for the same term. The purpose of this review is thus to present key terms, find a common ground, identify implementation challenges and propose development pathways.

Methods To build a common understanding of key concepts and to facilitate non-ambiguous discussions, this paper introduces a glossary of the most frequently used terms related to temporal considerations in LCA. We perform a review of the level of integration of temporal considerations in different LCA phases (goal and scope definition, life cycle inventory analysis and life cycle impact assessment), analysing each temporal consideration with respect to relevant conceptual developments in LCA and its level of operationalization.

Results and discussion The presented development pathways derive from our review for the identified issues. We propose three key focal areas for integrating temporal considerations within the LCA framework: i) define the temporal scope over which temporal distributions of emissions are occurring, ii) use calendar-specific information to model systems and associated impacts, and iii) select the appropriate level of temporal resolution to describe the variations of flows and characterisation factors.

Conclusions Addressing more temporal considerations within a dynamic LCA (DLCA) framework is expected to reduce uncertainties and increase the representativeness of results, but possible trade-offs between additional data collection efforts and the increased value in the representation of the results should be kept in mind.

Keywords: dynamic LCA, temporal considerations, review, recommendations

1 Introduction

Temporal considerations have been identified as one of the inherent limitations in life cycle assessment (LCA) [1, 2]. The relevance to compare properly the environmental sustainability of products, services or systems has been explored, debated and confirmed by the community during the last 20 years [3-5]. The dynamic of human activities [5-9] and the environmental responses to human pressures [4-6, 10-14] combined with the chosen temporal boundaries [15-17] have been identified from previous research as important temporal considerations. A histogram of publication in Figure 1 reveals the growing awareness for the subject, showing some of the identified temporal considerations within in LCA¹.

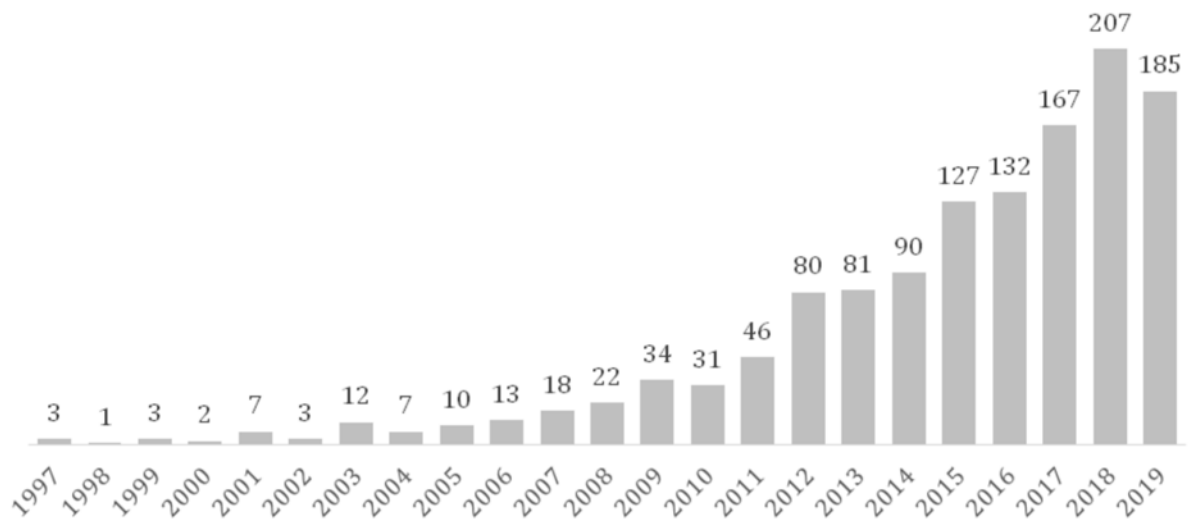

Figure 1: Numbers of LCA publications per year where temporal considerations are discussed

Within the identified 1281 publications, 51 review papers present several discussions about temporal considerations in different sectors (*e.g.* agriculture, building and energy) or in the general LCA framework. The vocabulary used in these reviews varies considerably, but common aspects can be found, such as the temporal scope or time horizon, which will be further clarified in the glossary (see section 2). While many ideas, concepts, approaches and tools have been suggested by researchers and are now used in publications under the term “dynamic life cycle assessment” (DLCA), their widespread implementation by practitioners of the LCA community is still far from reached. The lack of temporal considerations in most LCA studies is concerning since it was shown that such aspects

¹ The annual numbers of publications were found with the advance search function on web of science. The following words and conditions were searched for in the topic section: (“life cycle assessment” AND temporal) + (“life cycle assessment” AND “time horizon”) + (“life cycle assessment” AND dynamic). The word “time” was not part of the search to avoid mentions of the time required for data gathering activity and because it can be part of words like “sometimes”. The search was made on the 17 of December, 2019, meaning that 2019 is an unfinished year.

(mainly for the energy and building sectors) may have significant effects on LCA results [18-23]. It seems important to identify the current implementation challenges that prevent LCA practitioners in all sectors of the economy from more frequent temporal considerations. To our knowledge, only one recent work proposes a global overview of the temporal aspects that could arise in LCA (Sohn et al., 2019). In their work, three types of dynamisms are assessed: dynamic process inventory, dynamic systems inventory and dynamic characterization. We choose a different perspective on dynamic classification, and also suggest practical development pathways in DLCA. Consequently we are convinced that both papers bring added value on temporal consideration in LCA.

The aim of this review is therefore to: i) present an overview of key terms related to temporal considerations in LCA, ii) find a common ground between the existing DLCA approaches, iii) identify the current implementation challenges in LCA studies, and iv) propose development pathways for the goal and scope definition, representativeness of the results, and consideration of system dynamics. The structure of the review follows the general phases of the LCA framework [1, 2].

2 Proposed Glossary

Table 1: proposes key term and definitions to discuss temporal considerations within the LCA framework. These terms are used throughout this review to ensure a consistent and non-ambiguous discussion for future developments. It is also the authors' hope that this glossary might bring some consistency in future discussions. Words in brackets are synonyms from the literature. Definitions have also been recently proposed for DLCA and four sub-types (Sohn et al., 2019). Most of the proposed terms below are new, and when not are aligned with these definitions.

Appendices

Table 1: List of proposed terms defining key temporal considerations in the LCA framework. Links between terms are highlighted with italic font.

Term	Definition
Dynamic LCA (DLCA)	LCA studies where relevant <i>dynamic of systems</i> or <i>temporal differentiation</i> of flows are explicitly defined and considered.
Dynamic LCI (DLCI)	Life cycle inventory that is calculated from supply and value chains where <i>dynamic of systems</i> or <i>temporal differentiation</i> are considered, resulting in temporal distributions to describe elementary flows.
Dynamic LCIA (DLCIA)	Characterisation models of environmental mechanisms that take the time dimension into account and are therefore able to use temporal information of <i>DLICs</i> . <i>The temporal differentiation</i> (e.g. day, season, and year) depends on the impact categories. Both case specific and calendar-based characterisations can be used, depending on the chosen indicators.
Dynamic of systems	System modelling that considers inherent variations, periods of occurrence or evolutions within the temporal scope of models' components.
Evolution	Changes of process, structure or state <i>models' components</i> (e.g. technology replacement, pollutant concentration in a compartment of the environment).
Inherent variations	Variations of flows in the <i>models' components</i> (e.g. cycles of solar energy production). The discontinuities of flow rates are also part of such changes.
Models' components	Information structuring all models. At the technosphere level, components are elementary flows, product flows and processes. At the ecosphere level, components of LCIA models differ between impact categories. For example, components for freshwater ecotoxicity can be environmental fate, ecosystem exposure and ecotoxicological effects [24].
Period of occurrence	The moment when a <i>model's component</i> is starting, modified or finishing over time (e.g. lifespan of a building, beginning of waste management, start of a life cycle).
Period-specific characterisation factor (CF)	CF for a given <i>temporal scope</i> or <i>period of occurrence</i> . It results from the <i>dynamic of systems</i> in the ecosphere and can be calendar-specific, relative to the length of the <i>temporal scope</i> , or defined by a <i>TH</i> .
Period of validity	The period over which datasets, LCIs or LCIA methods are considered valid representations. This information should be calendar-based. [Time context (ILCD), time frame, range of time, period of time, time period, timespan, temporal boundary, time scale and time horizon]
Prospective modelling	A prospective LCA addresses future life-cycle impacts using different modelling strategies (e.g. scenario-based, technology development curves and agent- or activity-based models). The <i>evolution</i> of systems is thus defined and/or simulated using a list of explicit assumptions regarding the future. <i>Prospective modelling</i> can be applied to both the technosphere and ecosphere and is a subset of the <i>dynamic of systems</i> , which only concerns predictions for the future.

Temporal considerations	Any aspects (i.e. information) described in relation to the time dimension or <i>dynamic of systems</i> in the LCA framework. This is the overarching term relating to all other terms of the glossary. [Time-aspect in ILCD documents]
Temporal scope	Defines any type of period, which is covered by a LCA study (e.g. temporal considerations along a life cycle, service life of a product, data collection date).
Temporal differentiation	The action of distributing the information on a time scale related to the <i>models' components</i> . For example, elementary flows could be described per day, month or year. Different processes representing yearly average are another example. [Temporal segmentation in ILCD]
Temporal resolution	Describes the time granulometry when <i>temporal differentiation</i> is carried out. For instance, a monthly or daily resolution can be used to describe the flows in technosphere models. The same term can also be used to describe the <i>time step</i> for period-specific characterisation factors (CFs). [Time step]
Temporal representativeness	Qualitative or quantitative assessment of data, processes or LCIA methods in relation to how appropriate their information fits with their <i>temporal scope</i> . [Time-related representativeness (ILCD), Time-related coverage (ISO14044)]
Temporalisation	Attribution of temporal properties to the <i>models' components</i> . (e.g. definition of <i>temporal scopes</i>)
Time horizon (TH)	Relative <i>temporal scope</i> over which environmental impacts are cumulated to provide LCA results.

3 Temporal considerations in different LCA phases

Many temporal considerations have been described in previous publications, reports and standards to develop the general LCA framework [1, 2, 25] and its dynamic counterpart. An interesting analysis of DLCA studies is done in the supplementary information of Sohn et al, (2019). They classify the reviewed publications by their technological domains and by their types of assessed dynamisms (dynamic process inventory, dynamic systems inventory and dynamic characterization). In this paper, the level of relevance, conceptual development and operationalization are qualitatively assessed with scores ranging from A (highest) to C (lowest) (detailed in table 2) to evaluate the state-of-the-art shown in table 3. The given overview organises the temporal considerations by the main purposes and the LCA phases. A more detailed description, including examples, is provided in the following subsections to clarify the qualitative appraisal of table 3. Possible temporal feedback between the LCI and LCIA are not assessed, although they may influence LCA results [26]. The interpretation phase is excluded because specific temporal considerations have not been identified.

Table 2. Definitions of different scores for the qualitative assessment of temporal considerations in LCA

Ranking categories	A	B	C
Relevance	Demonstrated at least in some LCA studies	Expected by authors of this article	Unknown
Conceptual development	A standard method accepted by the LCA community	At least one method for consideration has been proposed	Theory or concepts have been explained
Operationalisation	Available in the data of most LCA studies when relevant	Some examples have been published	Not found in the literature

3.1 Phase of goal and scope definition

In the goal and scope definition, temporal considerations can be introduced by the modelling assumptions, data quality requirements (DQRs) and model limitations. They mostly offer insights on the temporal scope in which LCA studies are representative and useful. This temporal scope also provides an indication of when dynamic of systems should be considered.

3.1.1 Modelling assumptions

Definition of lifetime

The lifetime of systems or products [7, 9, 27-32] is probably the most common temporal consideration in LCA studies, which frames the use phase of the life cycle. This temporal scope, which is relative to the overall life cycle, has often been used to ensure a fairer comparison [25, 33]. However, more comprehensive temporal information on the full life cycle, which is not mandatory in international LCA standards [1, 2], would be necessary to explicitly frame the full temporal scope over which elementary flows and impacts might occur. For example, a house can be used for a lifetime of 50 years [34], but this temporal scope does not include the phase of forest growth, providing wood for the fabrication of the building's components [35, 36].

Temporal aspects considered in functional units

Some practitioners have suggested that the temporal scope should always be provided with the definition of questions [5, 37, 38] and functional units (FUs) [39, 40]. The concept of dynamic FUs has been proposed [41] which could consider the evolution of products and would explicitly define the period of validity for a LCA study when the behaviour of consumers and markets have changed. For example, the rapid evolution of technologies for mobile phones has changed their functionalities and demand, which then has modified their global production volumes.

Table 3: List of key temporal considerations in the life cycle assessment framework. Rankings for relevance, conceptual development and operationalization are provided for each type of consideration on a scale from A to C (explanation in Table 2). Horizontal arrows show time considerations that have more than one purpose. The numbers for rows are text’s subsections.

Section in present study	Temporal considerations	Purposes of the temporal considerations		
		Defining the temporal scope	Increasing the temporal representativeness	Considering the dynamics of systems
3.1 Phase of goal and scope definition		[relevance/conceptual development/operationalisation]		
3.1.1 Modelling assumptions	Lifetime definition	[A/A/A]		
	Dynamic FU	[A/B/B]		
3.1.2 Data quality requirements (DQR)	Age of data	[A/A/B]		
	Technology level	[A/B/B]		
	Sources of data	[A/C/A]		
	Uncertainty definition	[A/B/B]		
3.1.3 Limitations	Life cycle phases	[A/A/A]		
	Short- vs Long-term	[A/C/B]		
	Life cycle inventories	[A/B/B]		
3.1.4 Return of investment indicators (ROI)	Payback time	[B/B/B]		
	Discounting	[C/B/C]		
3.2 Phase of life cycle inventory: System modelling		[relevance/conceptual development/operationalisation]		
3.2.1 Dynamic of systems	Evolution			[A/B/B]
	Inherent variations			[A/B/B]
	Temporal resolution			[B/B/B]
3.2.2 Prospective modelling	Historical trends		[A/B/B]	→
	Simulation approaches		[B/B/B]	→
	Use of scenarios		[A/B/B]	→
3.3 Phase of life cycle inventory: LCI computation		[relevance/conceptual development/operationalisation]		
3.3.1 Framework	Matrix-based			[A/B/B]
	Graph traversal			[A/B/B]
3.3.2 Approach and Tool	DyPLCA			[A/B/B]
	Temporalis			[A/B/B]
3.4 Phase of life cycle impact assessment phase		[relevance/conceptual development/operationalisation]		
3.4.1. Modelling choices	Time Horizons	[A/A/A]		
	Period of validity	[B/B/B]		
3.4.2 Variations of substances in the environment	Elementary concentration		[B/B/C]	→
	Non-linear mechanisms			[B/B/C]
	Specific resolution			[B/C/C]
3.4.3 Prospective modelling	Evolution scenarios		[B/B/B]	→

3.4.4 Computational framework	Period-specific CFs	[B/B/B]	→
	Characterisation functions	[C/C/C]	→

3.1.2 Data quality requirements (DQR)

Age of data

Temporal representativeness of data and datasets, which should be defined in the DQR [1, 25], informs on the age of data and minimum length of time for data collection. Potential temporal discrepancies between used datasets and the targeted temporal scope of a modelled system can thus be partially evaluated with this metadata. Such information also provides some insights on the temporal scope within a system model when it represents human activities [9, 42]. For example, the description of solar energy installations from the 1990s would probably be relevant for LCA of solar energy before 2000, but this period of validity requires expert opinion, thus limiting the usefulness of this metadata.

Technology coverage

In some cases, the definition of technology coverage in the DQR of data and datasets can inform on the actual temporal scope of the study [1, 2, 25] with the ensuing qualitative assessment of temporal representativeness. For example,ecoinvent [43] uses five levels of technology (new, modern, current, and out-dated) to describe transforming activities. Using datasets with new or modern technology levels should therefore be relevant for LCA studies on future products. However, this information is relative to each sector, as the modern level could be representative for 10 years of technology evolution in an established sector, whereas fast-paced sectors like electronics could use modern technologies for only 1 year before switching to new options.

Sources of data

The choice of data sources and the qualitative assessment of their overall representativeness provide an indirect assessment of the temporal scope for modelled systems and LCA studies. For example, when data are sourced from scientific journals, date of publication is the primary indication for its period of validity. Temporal information that is more precise is also often provided in case studies of systems with longer lifetimes or for DLCA studies [4-9, 18, 19, 27, 30, 32, 38, 44-56]. The use of up-to-date LCA databases can bring a false sense of security on the temporal scope and representativeness of the data for recent products or systems. Indeed, database updates do not always follow the changes in market shares or evolution of technology because of the lack of new data. Nevertheless, different temporal metadata are given for most datasets. For instance,ecoinvent guidelines [43] require the definition of the date of generation, the date of review and the period of validity with a start date and end date for any dataset. These temporal considerations fulfil most of the requirements of ISO 14044 [1] except for the definition of the averaging period of dataset inputs. The ILCD handbook has set

further requirements defining temporal properties: the expiring year of datasets and the duration of the lifecycle, which respectively relates to the period of validity for LCI datasets and the temporal scope of elementary flows for a dataset. These metadata are available in most datasets of the ELCD [57]. Many of these temporal metadata are more relevant to assess the temporal scopes of studies than the choice of a database and its version, but the place (e.g. in dataset descriptions) and the different definition under which they can be found prevent their use in most LCA studies.

Uncertainty definition

The description of the uncertainty associated with flows (e.g. in ecoinvent [43]) is another indirect source of information to clarify the temporal scope and period of validity. Indeed, the temporal correlation indicator provides a quantitative assessment of the discrepancy between the time when the data was acquired and the intended temporal scope for the dataset [58]. For example, a product flow with a temporal correlation indicator of 3 means that its value has been gathered between 6 and 9 years before or after the targeted temporal scope of the dataset. With the current definition of the temporal correlation indicator, the precision of this temporal information is rather low (i.e. >3-year period) and is largely missing in LCA databases and studies, limiting its applicability.

3.1.3 Model limitations

The definition of limitations in the stage of goal and scope definition is probably the step where temporal scopes are defined with higher precision and clarity in LCA studies, even more so in recent DLCA studies. While this is useful, typical LCA reports mainly offer qualitative definitions, which are not sufficiently transparent to describe the considered period in assessed life cycles.

Considered phases of the life cycle

LCA studies can limit the temporal scope of their systems and LCIs by considering only a part of the life cycle. Setting the end-of-life outside the boundaries is an example of such a limited temporal scope. The ISO 14044 [1] allows this limitation, but only if they do not significantly change the overall conclusions of a study because such phases are not linked to significant impacts. Most of the LCA reports clearly state the ignored life cycle phases, but it only provides an imprecise description for the limitation of the temporal scope. The specification of the considered phases of a life cycle will neither explicitly state the temporal scope in which elementary flows are considered (e.g. 2 years) nor a calendar-based period of occurrence (e.g. from January 2019 to December 2020).

Short- vs long-term analysis

Several publications [4, 5, 8, 19, 32, 53, 54, 59-63] describe temporal scopes with adjectives such as short-, medium- or long-term. These qualitative and relative attributes can inform about the considered periods for the modelled system or impacts, but are still vague. This lack of a precise temporal definition for short-, medium- and long-term can be partly explained by the differences in time scales

of life cycles and environmental impacts for different systems, but it also provides evidence that no consensus has been reached on the definition of relevant temporal scopes.

Temporal description of life cycle inventories

More specific and precise descriptions of temporal scopes for LCI have been provided in recent scientific publications that focus on some temporal considerations (i.e. DLCA). For example, relative temporal scopes have been used to define the periods of LCIs for many studies on different products [10, 16, 19, 48-51, 64, 65] with descriptions like “a 100-year period” because of its link with the typical CFs for the assessment of global warming potential (GWP). In these cases, the LCIs are enclosed within a quantified period of time that can be relevant for some impact categories, but they lack any reference to a calendar year or period. Other DLCA [17, 18, 23, 32, 38, 44, 45, 55, 56, 66-68] provide calendar-based temporal scopes for LCI but discussions on the potential usefulness of this contextual information could be enriched.

3.1.4 Indicators for return on investment (ROI)

Two main ROI indicators provide specific types of temporal scopes: the payback time (used mainly to analyse renewable energies) and the discounting rates (used for impact assessment).

Payback time

The basic idea of a payback time, in the LCA framework, is to calculate the necessary period during the use phase to compensate for the “cradle-to-gate” impacts of any system. It has mainly been used to analyse renewable energy options [69-74] to evaluate the time it takes to produce the amount of electricity that compensates the production energy for the infrastructure. Results from this indicator are always expressed in months or years. They could thus provide another type of temporal scope to analyse some products, services or systems in the future.

Discounting

This concept was discussed to value time in LCIA [75, 76] and to deal with the uncertainties associated to time preferences and future emissions. The setting of finite THs is an implicit form of discounting long-term impacts, using a zero discount rate; setting infinite THs is the opposite. Discounting offers a trade-off between giving a higher value to present or future impacts.

3.2 Phase of life cycle inventory: System modelling

In the system-modelling step of the LCI phase, temporal considerations are found in the descriptions of the system inherent variations and evolutions. These considerations define the dynamics of systems and can improve the temporal representativeness of models for technosphere activities (i.e. network of processes). Although the considered system evolutions and inherent variations in both the foreground and the background data are still not a common practice, its importance has long been acknowledged

in ISO 14040 [2], stating that “*all significant system variations in time should be considered to get representative results*”.

3.2.1 Dynamics of systems

The periods of occurrence, inherent variations and evolutions are key temporal considerations in LCA models. Strategies considering these changes have been proposed by different authors, mainly in the energy [20], transport [77], agricultural [78] and waste management [79] sectors. For example, the energy share of electricity production in a country varies throughout days, weeks, months and seasons [80, 81]. LCA case studies have shown that the inherent temporal variations of production can have significant effects on results, mainly when consumption of these products is not constant over time.

Modelling evolutions with process differentiation

The basic strategy to describe such inherent variations is to differentiate processes when a system is considered to change substantially over time. The key challenge here is to identify when changes are significant enough without expert opinion on the modelled product. A simple application can be performed, if calendar-based periods of validity are consistently provided for all datasets in LCA databases; they could then be changed automatically when they are no longer valid representations over the full life cycle of any system. Such metadata is, however, required only in the (discontinued) ELCD database (see subsection 3.1.2) and, currently cannot be easily integrated in LCA software. Collet et al. [82] proposed an approach to tackle this problem and identify where temporal differentiation of processes during system modelling is needed. Their general idea is to recognise when the combined emission and impact dynamics justify the additional effort for temporal differentiation. Moreover, the selective introduction of the time dimension in background processes has been studied by Pinsonnault et al. [64] and more recently by Pigné et al. [76]. The authors have shown that the temporal variations of, respectively a selection of background processes and the entire ecoinvent database, can significantly affect the climate change impact of processes in some sectors (e.g. transport and building).

Modelling inherent variations with flow differentiation

Inherent variations can be modelled with temporal differentiation of elementary flows. For example, electricity consumption in buildings varies between hours, days, weeks and seasons [17, 18, 21, 44, 45, 80]. The modelling approach converts the amounts of flows into temporal distributions, thus supplementing temporal properties to the core data of the model components in the LCA framework. The dynamics of flows have recently been used in DLCA studies to describe the electricity use of specific buildings [18, 45, 80], while reducing the need to define new foreground processes for each time step. The applicability in other LCA studies is limited because the temporal information is valid only within the temporal scope of a given case study. Conceptually, a way to address these issues is by defining a “time 0” in the temporal distribution as a period of occurrence relating to a starting period

Appendices

of a process [67, 83]. This “time mark” creates process-relative descriptions, which can be reused in any period of a life cycle or even for different life cycles. Tiruta-Barna et al. [67, 76] provided process-relative temporal distribution archetypes for ecoinvent v3.2, applicable to foreground and background datasets. As underlined by Beloin et al. [83], the additional efforts needed to provide temporal information for all the flows of LCA databases are still significant and the prioritisation of data-gathering remains important.

Temporal resolution

The level of temporal resolution to models the dynamics of systems depends on the sector and the modelling approach. For instance, hourly resolutions have been chosen for electricity production and consumption [20] or the transportation sector [77]. For assessing long-term emissions, for instance from waste treatment, a temporal resolution of centuries is more appropriate [79]. Some authors have proposed a temporal differentiation based on archetypes. For example, archetypal weather days [84] have been developed to contrast the relative importance of episodic wet weather versus continuous dry-weather loads. So far, studies about the consequences for choosing different temporal resolutions to describe the flows are limited: only two examples are found for the building sector where a monthly resolution is deemed sufficient to consider most of the temporal variability [44, 81].

3.2.2 Prospective modelling

Modelling future evolutions of systems is another common example of temporal considerations that is often performed under the umbrella of DLCA studies. Indeed, many DLCA studies have explored different prospective models for a range of products like photovoltaic panels [85, 86], buildings [87-90], bioethanol [91], passenger vehicles [92-94] or ammonia [95]. Any temporal assumptions made to define future evolutions are thus considered for system modelling and LCI calculations. While major advances have been made to offer explicit descriptions of assumptions made for temporal considerations in DLCA, e.g. [17, 19, 21, 86, 96], they are currently not the standard. Prospective modelling assumptions can be grouped within three categories that have fundamental differences on how they justify their previsions or predictions of the future.

Predictions based on historic trends

Some data sources (e.g. statistics on energy production) describe historic trends from which predictions are made by extra- or interpolation, assuming that paradigm shifts will not occur. For instance, regression analysis was used to assess the evolution of energy systems [86, 97, 98] and the construction sector [99]. The main strength of this approach is its simplicity and the potential to assess the observed level of variability of historic trends. It can thus provide averaged predictions of future trends and the expected variability (uncertainty). The main weakness, on the other hand, is the implicit assumption that historic trends are representative of the future, which is not always the case, particularly for emerging systems and technologies.

Simulation approaches

Economic models, such as partial equilibrium models (PEM) or general equilibrium models (GEM), are frequently used in, but not limited to, consequential LCA modelling to simulate potential future evolutions to assess direct and indirect consequences of decisions (e.g. climate policies) on large scale systems. The former generally focuses on one particular economic sector with a higher level of detail (i.e. technology rich), while the latter covers the whole economy with a lower level of detail (typically 30–50 economic sectors). PEMs have been used to model the energy sector in France [19, 100], or biogas production in Luxembourg [101]. GEMs have been used to evaluate the consequences of different energy scenarios on the whole economy in Europe [102]. PEM and GEM have also been coupled together to model the consequences of energy policy scenarios in an integrated manner [103].

The lacking consideration of human behaviour in PEM or GEM has recently been pointed out as a potential issue for the validity of the predictions [104]. The use of agent- or activity-based models have therefore been proposed to model the agent-agent and agent-environment interactions; both in the foreground and in the background systems. This approach has been used in consequential LCIs relating with transport policies [105], regional market penetration of electric vehicles [106], switch grass-based bioenergy systems [107] or raw materials criticality [108]. Deeper analysis of differences and similarities of consequential LCA and DLCA can be found in Sohn et al. (2019).

Using scenarios to explore potential futures

Scenario-based modelling has been used in waste management [109], water consumption [110], bioenergy [19, 61, 111-114], renewable energy, [115], chemical production [116] and building [21] sectors. Pesonen et al. [117] defined that the scenarios describe possible future situations based on assumptions about the future and include developments from the present to the future. The authors distinguished between “what-if” and “cornerstone” scenarios [117], depending on the need to consider short- or long-term planning. What-if scenarios are often based on the field-specific expertise of LCA practitioners. Cornerstone scenarios explore many options with very different assumptions on the future to identify potential development paths. Another category is legally bound scenarios that explore future paths under the restriction of regulations. A general idea behind modelling scenarios is that exploring potential future paths may be simpler to justify than proposing future predictions.

3.3 Phase of life cycle inventory: LCI computation

The computation of LCI transforms the information of the systems’ models into a set of elementary flows whose quantities are in relation to the FU of the assessed systems. The computation traditionally aggregates all flows of the same type over the entire life cycle. The DyPLCA and Temporalis tools (introduced in section 4.3.2) have been proposed to modify the computational framework to avoid losses of temporal information. Both approaches are now available within different software tools and approaches for a comprehensive consideration of temporal descriptions in LCA studies.

3.3.1 Framework

Matrix-based computation

The conventional matrix-based computational approach can still be used but with larger technosphere and ecosphere matrixes [118]. Collinge et al. [17, 119] used this approach on foreground processes to calculate the LCI for each year of a building's life cycle. They concluded, similarly to Heijungs et al. [118], that the implementation brings significant challenges in data management when background databases are used. The challenges are twofold. Firstly, the temporal description of a system needs to be re-informed when the periods of assessment differ (*e.g.* 1900-2000 vs 2005-2025), if the considered impacts are calendar-based. Secondly, the amount of data and the computational effort depend on the required temporal precision (*e.g.* day vs. year) to describing all flows.

Graph-based approaches

In the Enhanced Structure Path Analysis (ESPA) approach [83], the computational framework convolves process-relative temporal distributions (see subsection 3.2.1) to propagate the temporal descriptions of flows. The general concept behind the ESPA framework [83, 120] relates to one strategy of graph traversal algorithm (*i.e.* breadth-first), but other options have been also explored. The depth-first search strategy [67] recommends a different traversal of supply chains, which is normally linked to lower memory requirements. The best-first search strategy [68] is another option that propagates the temporal information by prioritising the temporal distribution with relative higher contributions to impacts. All these options use process-relative temporal distributions, thus profiting from their reusability and the potential for higher temporal precision.

3.3.2 Approaches and tools

Some commercial software tools use matrix-based computation (*e.g.* Simapro, Umberto) and could thus work with the process differentiation framework for the calculation of temporally differentiated LCI. To our knowledge, this option has not been implemented in DLCA studies because LCA databases do not offer temporal details. The ESPA method has also not been developed into a computational tool and its implementation has been limited to one simplified case study [23]. Nevertheless, two options currently exist for DLCI computation introduced as follows.

DyPLCA

DyPLCA has been implemented as a web tool (available at <http://dypzca.univ-lehavre.fr/>), originally presented in [67], using the depth-first graph search strategy. The main parameters that balance accuracy vs. computation time in this tool are the temporal resolution of function integrals and the back time span. Common values for both are respectively 1 day and -50 years (*i.e.* 50 years before the period of occurrence for the FU). The computational intensity of the DLCI calculation has thus been resolved by a trade-off between accuracy and cut-offs. The process-relative temporal distributions can have different levels of detail to describe the flows in the system models. For instance, they can be

detailed for foreground processes, as presented in Shimako et al. [121], and rather generic for the background datasets.

DyPLCA currently works with a temporal differentiated ecoinvent v3.2 [76], providing generic temporal descriptions to most background inventory processes. The DLCI results can be further used with static or DLCIA methods, as shown in studies on bioenergy production from microalgae [122] and on grape production [123].

Temporalis

Temporalis [68] is a free and open source package of the Brightway2 LCA tool [124], using the best-first search strategy. The tool is fully compatible with many existing commercial LCA databases, but temporal descriptions of datasets are currently not provided. Temporalis does not require a fixed and continuous temporal resolution over any system models to provide DLCI or results for the impact assessment. Nevertheless, a DLCIA method for GWP based on the IPCC methodology [125], is included. A simple case study for the temporal consideration of biogenic carbon flows was carried out with the method of Cherubini et al. [126, 127]. It has shown that the LCI computation can be resolved on a regular laptop within a short time. Nevertheless, further developments still need to be completed before LCA practitioners can use the tool.

3.4 Phase of life cycle impact assessment

In the LCIA phase, temporal considerations can describe the evolutions or inherent variations of impacts over time and eventually define temporal scopes of some categories. Changes of environmental mechanisms (i.e. impact pathways) over time and the selection of a time horizon (TH) are key modelling choices to characterise impacts in the LCA framework.

3.4.1 Modelling choices

LCIA is a complex task, which requires many assumptions (e.g. the future state of the environment) and choices that sometimes limit the validity of results to a specific temporal scope and introduce uncertainty in the results. One of the most explicit and commonly used temporal considerations in LCIA methods is the TH, restricting the impact assessment to a specific period. The defined periods of validity, on the other hand, can be used to explain when LCIA methods must be updated to reduce uncertainty.

Time Horizon (TH)

A common type of temporal considerations, in most of the current LCIA methods, is performed by choosing between a finite or infinite TH over which environmental effects are integrated in cumulative metrics such as the GWP. To date, the choice of a TH remains a topic of discussion within the LCA community [4]. In the case of GWP, the 100-year TH is the most used and recommended choice. This

Appendices

preference is, however, not justified by scientific facts [4, 128, 129] and is implicitly subjective for decision-making [130, 131]. Indeed, the 100-year TH differentiates short- from long-term perspectives particularly when valuing and incentivising temporary or permanent carbon storage and delayed emissions of biogenic and/or fossil sources [132]; whereas delays above 100 years are not considered [133, 134]. Another option for the consideration of different THs is given by the ReCiPe method [135]. It builds on three cultural perspectives, proposed by Hofstetter et al. [136], which are associated with a different set of calculation assumptions, including different THs for each impact category. For example, the “hierachist” perspective retains a 100-year TH for GWP and other categories, while “Individualist” and “egalitarian” perspectives use THs of 20 and 1000 years respectively.

Two critical aspects are still challenging the current use of fixed and finite THs in LCIA methods. The first aspect is the inconsistency between the temporal boundaries of the studied systems and the TH of the LCIA methods [10, 137, 138]. It could be understood that the effects from elementary flows beyond chosen TH should not be considered. However, the effects are ultimately modelled over an invariable temporal scope, even if they occur at different periods during a life cycle (e.g. 100 years). THs may thus lead to misrepresentations of impacts and their period of occurrence [139], for instance, misinterpreting temporary storage and emission delays [131, 140]. It can be particularly relevant for intermitting emissions like pesticides, where an arbitrary cut-off of emissions after pesticide application should influence how each emission contributes to related impacts of human toxicity [141] and ecotoxicity [142]. Furthermore, currently there is no standard on how to deal with long-term impacts and related uncertainties within all categories. For instance, the 5th IPCC assessment report [143] removed the 500-year TH due to high uncertainties associated with the assumption of constant background concentrations.

The second aspect refers to the time integration of substances with highly variable environmental effects over their lifetime (e.g. aging effects reducing bioavailability and related effects of metals [144]), which can significantly bias the conclusions of LCA studies [59]. In the case of GWP, the weight of forcers with very short atmospheric residence time decreases with an increasing TH [145, 146], while a shorter TH increases the impact for short-lived gases. For example, methane (CH₄), whose atmospheric lifetime is about 12.4 years, goes from a factor of 84 CO₂-eq for the 20-year TH to a factor of 28 CO₂-eq for 100-year TH [143]. For further examples on this subject, Levasseur, et al. [146] present various approaches that have been proposed for TH definition. For toxic substances, Huijbregts et al. [147] demonstrated that TH variations can change impacts by up to 6.5 orders of magnitude for metal toxicity. In this case, the high dependency between CFs and the chosen TH is due to long residence times (i.e. persistence) in fate models, which increase metal run-offs and leaching potentials to global marine and soil compartments.

Temporal cut-offs from THs are further ethically questioned in the context of intergenerational equity [75]. A “simple” solution to remove such time preferences and value choices has been recommended by setting infinite THs. For instance, some LCIA methods (e.g. EDIP2003 [148], IMPACT 2002+ [149], ReCiPe 2016 [135]) use infinite or indefinite THs as a standard for stratospheric ozone depletion, human toxicity and ecotoxicity. Moreover, some methods, such as ReCiPe 2016 [135] consider very long THs for climate change (i.e. 1000 years) and ionising radiation (i.e. 100 000 years). The ILCD handbook [134] and the SimaPro Database Manual [150] give more insights into the use of such THs in different LCIA methods.

Period of validity for LCIA methods

Calendar-based period of validity for selected LCIA methods in LCA studies are not often defined, but they can inform on the temporal scopes [38, 52, 58]. For example, the choice of THs would suggest an implicit definition of the considered temporal scope. In an ideal world, the temporal scope of obtained LCIs and chosen LCIA methods should fit. Such a correspondence is desirable if CFs that vary significantly over time, but it is currently difficult to implement in the available databases and software tools.

3.4.2 Variations of substances in the environment

In conventional LCIA methods, CFs have been determined with average or marginal approaches that model changes in the impact according to a change in the inventory [151, 152]. With the /average approach, the environmental disturbances from different process activities are aggregated, historically referred to as “snapshots” of a studied system [118, 146, 153-156]. For example, most existing models for characterising toxic impacts [157] assume constant environmental conditions for the assessment of health impacts. With this approach, inherent variations or evolutions are not considered.

On the other hand, the marginal approach addresses an impact resulting from a small change to a given background concentration. The impact is therefore positioned in relation to the current environmental state. For example, studies of human health impacts from exposure to fine particulate matter (PM_{2.5}), where indoor, outdoor, urban and rural locations have shown significant differences in PM_{2.5} background levels [158]. A non-linear exposure-response model thus accounts for these differences in PM_{2.5} levels, reflecting a slope for low concentrations that are substantially higher than for high concentrations [159].

Considering variations of concentration for substances in the environment

Impact assessment models are representations of complex environmental mechanisms that depend on a long list of parameters, such as the lifetime of substances in the environment and the sensitivities of ecosystems over different temporal scopes [160]. Consequently, elementary flows may have different levels of effect, depending on the timing of emissions. For instance, impacts characterisation methods

Appendices

often use an effect factor for a given concentration of pollutants in the background environment [5, 161]. Thus, the same amount and type of elementary flows (*i.e.* equivalent LCIs) can generate different levels of impacts because they have been emitted at different periods of occurrence (*e.g.* 2016 or 2017), with varying flows (*i.e.* inherent variations) and geographies, requiring both temporal and spatial differentiation.

Temporal considerations of environmental mechanisms in LCA studies are challenging because the current state of practice rarely allows accounting for the periods of occurrence of emissions related to a product's life cycle [4, 10, 139, 162-164]. In fact, LCI flows are given as simple values that are considered to be a representation of steady or pulsed flows from and to the environment by most LCIA models.

Non-linear mechanisms

In many LCIA methods, CFs are defined from generic parameters values in stationary conditions, (*e.g.* intervention quantity, baseline for target substances, and profile of the soil composition) or for a given TH. In reality, the involved environmental mechanisms are dynamic and often highly complex. They depend on the physical-chemical and biological phenomena occurring in nature and are consequences of the elementary flows generated by human activities. Independently from the CF definitions, impacts are assumed linearly proportional to the inventoried emissions, which enable the scaling of impacts to any functional unit.

Time-dependent impact characterisation has been performed in some cases by modelling the dynamics for one or more of the three factors influencing an impact (*i.e.* environmental fate, exposure, and effects), thus creating DLCIA methods. Effect data are typically not easily linked to temporal properties, allowing for temporal considerations in effect modelling (*e.g.* dose response for human effects or concentration response for ecological effects). Hence, time-dependent characterisation is usually only facilitated by considering the dynamics of systems in the fate and exposure factors of an impact pathway, which is usually enabled by models of the underlying mass balance for a given impact pathway. This has been implemented, for example, in toxicity-related impacts [59], where the system dynamics of the environmental fate part are either solved via numerical integration (*e.g.* [123]), or via matrix decomposition (*e.g.* [165]).

Specific temporal resolution for each elementary flow

The consideration of environmental impact variations over time within LCIA models may follow specific frequencies (*i.e.* how often it is performed), as well as temporal-inherent features deriving from dynamic biogeochemical processes. The frequency can be differentiated, for instance, as responding to episodic (*e.g.* initial land clearing), cyclical (*e.g.* seasonal water and pesticide use), stochastic with a certain recurrence interval (*e.g.* 1 in 20 years' waste discharge), or continual (*e.g.*

fisheries yields) variations in the studied system [160]. Such frequencies therefore highlight relevant temporal resolutions for the temporal differentiation of elementary flows in databases and DLCIs.

The temporal scope of impact assessment itself may be aligned with the dynamics of governing biogeochemical processes to more accurately represent certain fate dynamics. For instance, Liao, et al. [166] found that common seeding-to-harvest assessment periods in agricultural LCAs do not correspond to the actual dynamics of fertilising substances, some of which contribute to eutrophication during the next crop rotation. The same concerns agricultural pesticides, where the time between the application and crop harvest drives related residues leading to human exposure [167]. However, such fate dynamics can still be analysed and parameterised to fit steady-state characterisation models and associated impact pathways, such as human toxicity [14, 165]. Cyclical or seasonal variations concerning sunlight, temperature and precipitation on the calendar year (e.g. winter vs summer time) are other examples of temporal considerations that could be relevant for impact categories like aquatic eutrophication [168], water scarcity [169], human toxicity [12] and photochemical oxidant formation [13]. Moreover, temporal patterns of characterisation can be drawn from inherent temporal variability linked with hourly, daily, monthly or yearly constraints [154, 170].

3.4.3 Modelling prospective time horizons

Another form of temporal considerations in LCIA is increasingly performed on scenario-driven case studies. It has been applied to water use impacts by means of scenario-bound CFs, where each scenario represents a different prospective TH [171]. It is a step towards temporal variability of environmental indicators, as most LCIA methods make the implicit assumption that the environment and its properties will not evolve.

3.4.4 Computational framework

Recently, some DLCIA methods have been developed with different computational frameworks. These approaches are key to understand the links between DLCIs and DLCIA methods, while offering potential pathways for future developments.

Period-specific characterisation factors

In the last decade, LCA researchers have developed DLCIA methods addressing time dependent impacts as a function of time, yet they are mainly restricted to the GWP indicator. These DLCIA methods consider the periods of occurrence for emissions by providing different period-specific CFs to assess their impacts. These CFs thus bring consistency between the temporal scopes of DLCI and impacts [10]. Different LCA scholars found that the results based on such DLCIA methods provide useful examples for decision-making, among others, on: “the intensity, extend and frequency of the impacts” [65], the sensitivity of the results to various TH choices [174], and the optimisation options from scenario-bound simulations [123]. The DLCIA method developed by Levasseur et al. [10] is

currently one of the most recognised and sophisticated approaches, featuring period-specific CFs. In addition, calendar-specifications can be relevant to assess and compare the evolution of impacts and/or background concentrations over time (*e.g.* 1990 Kyoto Protocol and 1750 IPCC reference years for climate change).

Time-dependant characterisation functions

Recent works [121-123] have proposed to come back to the origins of impact simulation tools and adapt them by adding temporal information in the LCIA phase. The idea is to consider the opportunities of using DLCIs as inputs for DLCIA models. Such a DLCIA model has been proposed to assess toxicity impacts (human and ecotoxicity) by Shimako et al. [123] and applied in a full DLCA study. The model reintroduces the time dimension for fate modelling of substances in the environment, providing the temporal distributions of substances in different environmental compartments. The physical parameters for the calculation of fate, exposure and effect factors were taken from the USEtox model. This method doesn't propose period-specific CFs, but directly calculates the impacts by coupling the impact model with all the available information in DLCIs.

The definition of ecotoxicity according to time also allows to evaluating the intensity of the impact for different periods of occurrence, which supports the identification of critical periods for potential impacts. The cumulated toxicity then represents the total damage generated over a TH. When compared with conventional USEtox results, obtained in steady state conditions, the DLCA results are systematically lower, but toxicity tends towards the conventional results for an infinite TH. Non-persistent substances (generally organic) generate almost all their hazard potential during their periods of emission and disappear more or less rapidly due to the degradation or transfer to sink compartments (removal). In contrast, persistent substances accumulate in environmental compartments during the emission periods and their toxicity potentials remain high after the emissions stop, potentially affecting many human generations.

4 Proposed Development Pathways

It is rather straightforward to identify temporal considerations within the DLCA framework when the challenges of data availability and management are overlooked. Indeed, the general goal can be summarised by the desire to reach the highest level of temporal representativeness and to provide useful information, when considering the dynamics of system in all of the model components. It would seem relevant for:

- Firstly, clearly define calendar-based temporal scopes for all flows of a DLCI to outline the period of occurrence to justify the choice of specific DLCIA methods. The temporal information would set a clear temporal frame of reference of key interest for all stakeholders who want to identify the future effects of their decisions. A period of validity for the results of a LCA study should be set

as mandatory information to offer an explicit estimation of the period of the representativeness of the results and when updates would be necessary.

- Secondly, system and impact models should be based on calendar-specific information. As the models evolve beyond the defined temporal scope, this specification would thus highlight the proportion of impacts that will occur after the publication of a LCA study. Historic data could be used to model processes and impacts that happened before the publication date of the study. Prospective data based on forecasting strategies and CFs representing future impacts that will occur after the publication date would explicitly be reported to substantiate the basis for evolution of processes. A clear separation between historic and future-related results would explicitly show the proportion of impacts that can only be based on forecasting assumptions.
- Finally, the inherent variations of flows and CFs over a life cycle should be described with the necessary level of detail to minimise the temporal uncertainty on results. Temporal distributions of flows would be defined relative to systems' components for a common framework of assessment, which considers the dynamics of system that need to be modelled.

These conceptual targets for temporal considerations would increase our ability to differentiate the impacts of different systems by reducing temporal uncertainties, but the current challenge lies mainly in finding the right balance between additional efforts for data collection, data modelling and required temporal resolution levels. The search for such “simple-enough” implementation strategies is therefore the key to propose the next development steps for temporal considerations in DLCA.

4.1 Temporal considerations in the goal and scope definition

Temporal considerations, presented in section 3.1, mostly offer partial, implicit and qualitative information about when LCA studies have temporal representativeness or for when impacts are occurring. Temporal scopes of results in LCA studies are sometimes more explicitly defined, but they are not commonly provided, which hinders transparent and fair comparisons among results of other studies [5, 37, 55, 56, 61, 175]. Lack of consistency in the vocabulary that describes the models' components and the linked LCIs or LCIA methods also brings some issues to simplify the exchange of temporal information. These obstacles should be addressed access the wealth of information and metadata that is actually provided in LCA databases and studies. Two propositions are thus made for potential development pathways:

1. Recognition and use of a common structure and vocabulary to discuss and exchange on the subject of temporal considerations in the DLCA framework (section 2)
2. Automation for the management of information on temporal considerations should be pursued because significant increase in data need is to be expected for this subject.

Appendices

A specific example is the development of guideline to consistently define the different temporal scopes and periods of validity that should be provided in LCA databases and studies. The authors are well aware of the challenge in asking a community to accept a common framework for such a broad subject, but data providers would benefit from the identification of common patterns and of "translation" options between data format.

4.2 Time dependent modelling of human activities

Strategies to account for inherent variations and future evolutions of systems and impacts have always been implicitly considered in LCA. The mere goal of integrating elementary flows over the full life cycle is a testament of this. Nevertheless, most of the current studies show an implicit assumption that human activities and associated elementary flows and impacts will not change significantly over their temporal scopes or that such changes do not have to be considered to differentiate the environmental impacts of two products with equivalent functions.

Alternatively, DLCA studies start from the assumption that inherent variations, periods of occurrence and evolutions need to be considered. The basic principle that has been used in DLCA studies is to consider such levels of temporal considerations with process differentiation, which turns out to be challenging whenever a comprehensive and detailed description of the life cycle is expected because a large amount of temporal information needs to be defined in each LCA study. The differentiation of flows with process-relative temporal distributions is feasible but has yet not been implemented in commercial databases.

The second option should thus be combined with calendar-specific processes that are changed when they are no longer representative of the technology or activity over the considered life cycle (i.e. period of validity). The challenge in both cases is to identify the level of temporal resolution that is sufficient for minimising the temporal uncertainty while balancing the efforts to describe the models of human activities (i.e. data management and gathering). Some components might also have a fixed temporal definition to represent part of the human activities that will not change in relation to the temporal scope of the LCA study. For example, all elementary flows that are linked to the construction phases of hydro power plants in a country will not happen in different periods if they are linked to past or future products.

Given the current options, the next steps of development for system modelling are suggested, as follows:

1. Carry out a comprehensive research of methodologies and approaches where dynamic modelling is considered (e.g. dynamic MFA or dynamics of system, as it has been done with a simplified framework in DyPLCA) to identify strategies that might not yet be proposed for the DLCA framework.

2. Perform discussions with impact modelling experts to evaluate an acceptable level of temporal resolution for all elementary flows with the clear goal of minimising the temporal uncertainty on the CFs of newly developed DLCIA methods.
3. Provide process-relative temporal distributions to describe all flows and use these distributions within new computational tools and DLCA. The identification of key sources for temporal variability within systems is probably the best way to start this work and will increase our knowledge on the question in an iterative manner.

Moreover, the correlation of flows in current databases is mostly not defined (i.e. the output of a process is not an explicit function of the inputs, and emissions are not related to the consumption) even if this is possible in some LCI databases. From a mechanistic point of view, these relationships exist (e.g. carbon content in CO₂ from tailpipe emission depends on fuel consumption) and LCA practitioners when creating datasets can use them. However, this information is commonly left out from the LCA databases and only the results (i.e. the quantities of flows) are kept in the process description. By making these relationships explicit, one could simplify the introduction of time consideration in datasets, as some are intrinsically linked over time (e.g. nitrate emissions at the crop level are strongly related to the crop production cycle).

Another issue appears at the system level with co-product management. Indeed, the avoided product approach raises the question of how the avoided product(s) can be modelled in time. Should it be simultaneous to the co-product or following the co-product production, assuming that the replacement will take place afterwards?

A non-physical allocation also raises questions about temporal considerations. For instance, to ensure carbon balance, corrections are made when multi-output processes are split into several single-output processes. Artificial positive and negative CO₂ emissions are added up to match the carbon fixations to the carbon content of a product (Weidema, 2018). This approach is, for example, used in the ecoinvent database under “*At Point Of Substitution (APOS)*” and “*Cut-off*” system models [43]. It questions whether to maintain these flows in DLCA, and if so, how to position these artificial flows over time. Therefore the period of occurrence will be difficult to justify in DLCA. This matter should further be addressed to identify if some rules can be developed.

The use of prospective models in LCA studies could also be improved. The reason for using such models has always been to offer a perspective of the future that fits more with the expectations of LCA practitioners. It is important to recognise that it is currently challenging to find a consensus on a “best” option for any case study. In such a context, a more achievable goal is to ensuring maximum transparency of all choices made. It would also be useful to separate the impacts that are linked to past and present processes from the ones that are based on prospective models. This would clarify the share of impacts issued from modelling assumptions projected to the future.

4.3 Inventory calculation: keeping time in the modelling

The recently developed conceptual frameworks and tools (see subsections 3.3.1 and 3.3.2) employ a common computational structure based on graph search algorithms to calculate DLCIs. This structure uses process-relative temporal distributions to describe the flows within system models. Such a consensus suggests that the computational structure for DLCA and the corresponding tools could become a standard, but implementation challenges are still limiting their use in the LCA community. Overall, more DLCA studies should be carried out with these tools to increase the understanding of the LCA community and to develop the process-relative descriptions in LCA databases.

DLCA is intrinsically rooted on modelling the dynamics of systems. The many models' components describe a large system, featuring several thousands of processes in the technology matrix and many hundreds of elementary flows in the intervention matrix. The introduction of timed variables in the matrixes and vectors of calculation can induce non-linear trends, in the causal relationships. Delays might appear in the datasets (e.g. storage processes) or in the interventions (buffer zones at technosphere/ecosphere interface). The discontinuities form due to temporal switch between technical flows (e.g. seasonal supply) or abrupt release could also arise. All these aspects cause a real issue for solving, simulating and providing DLCA results under a reasonable computation time. Nonetheless, system dynamics is a well-studied topic in applied mathematics and control theory. The introduction of temporal considerations into the field of LCA would thus benefit from the knowledge of these research areas or disciplines.

Temporal resolution of flows in DLCA is another important aspect that will need further considerations. One LCA system can represent many dynamics, because of the size of the system and the inherent variations of the production processes, emissions and resource consumption, as well as of the environmental mechanisms. This issue has already been identified and discussed in some LCA studies where process dynamics are relevant. Collet et al. [176] discussed the necessary match between the emission dynamic and the impact category to justify such temporal considerations. Shimako et al. [121] dealt with the time step of simulations regarding the impact features and showed the gap between examples of climate change (year) and ecotoxicity (day). Urban traffic is another example of the time-resolution aspect that shows the relevance of intraday dynamic for commuters since they mainly travel at the beginning and the end of the working period. Moreover, let's consider, for the sake of clarity, that carbon dioxide and particulate matter both have an intraday emission dynamic. If this resolution seems suitable for the fate of particulate matter, it is clearly too short for climate change mechanisms, where a yearly resolution would be sufficient. The transportation activity also needs infrastructure, which is defined over decades, adding an even slower dynamics to the system. Consequently, urban traffic is a good example of a system that merges multiple time resolutions with fast and slow environmental effects. Consequently, the analysis of different systems

will be relevant to identify the temporal consistency in different subsystems (Kuehn 2015; Bertram and Rubin 2017).

4.4 Dynamics of impact assessment

Temporal considerations in methods for impact characterisation can also be introduced with the choice of specific THs. The recent developments in DLCIA methods have focused on the impact categories of climate change, toxicity and ozone depletion.

As explained before, environmental mechanisms for different impacts of substances will occur within diverse temporal scopes. These specific periods for each impact category can therefore provide guidance on the required resolution of temporal distributions to describe the elementary flows of LCIs, while minimising the temporal uncertainty. A clear list of the relevant time scales for each LCIA category would thus be useful to fix database requirements in the definition of elementary flows for any datasets.

Prospective modelling of CFs should also be considered based on, for example, projections of population density, or estimated particulate matter background concentrations. A clear identification of temporal parameters that affect the calculation of the CFs for the different impacts covered in LCA could thus be of an important added value for both prospective and retrospective modelling. Identifying the parameters that will be affected by future modifications of the environment could therefore be particularly relevant.

In addition, a clear definition of the temporal scope covered by the LCIA methods should be added for impacts with strong time dependency. The choice of a TH should be based on the case study goal and scope and impact category. Background concentrations should—where available and relevant—also be updated with different frequencies, depending on the impact category. Sensitivity analyses could be performed on concentration levels, in order to assess temporal variability of CFs, and to propose, if necessary, updated values for prospective and/or retrospective studies.

To carry out any of these developments, collaboration between experts of LCA databases, LCI computation and LCIA methods should be strengthened to develop a common framework for temporal considerations of any indicator.

4.5 Summary of potential development paths for temporal considerations

Table 4 presents a summary of the proposed developments from sections 4.1 to 4.4 with their main purposes and a qualitative assessment of the expected level of challenge to reach these targets. This assessment goes from + (i.e. basic efforts) to +++ (significant efforts). Separations between temporal considerations in the different phases of the DLCA framework are, once again, used to structure this summary.

Table 4: Summary of proposed development paths for temporal consideration in a DLCA framework

Proposed development paths	Purposes of the targets			Challenge level
	Defining the temporal scope	Increasing the temporal representativeness	Considering the dynamics of systems	
4.1 Time in the goal and scope definition				
Use of a standard glossary to describe temporal considerations in DLCA databases and studies	X		X	++
Use of common metadata descriptions to automate the exchange of temporal information	X		X	++
4.2 Time dependent modelling of human activities for LCI calculations				
Test the use of process-relative temporal distributions in DLCA studies to describes flows			X	++
Identify the relevant levels of resolution for different flows in the technosphere models		X	X	+++
Offer more explicit and complete list of choices made for prospective modelling	X	X	X	++
Split results between past and future impacts for the entire system and life cycle	X			+++
4.3 Inventory calculation with temporal properties				
Gather more information on the dynamics of systems for future DLCA studies		X	X	+++
Investigate the field of system dynamics to find useful ideas for the DLCA framework			X	+
Simplify the use of current approaches and tools to reach more LCA practitioners		X	X	+++
4.4 Dynamics of impact assessment				
Identify methods to consistently consider THs in DLCA studies for all impact categories	X	X		+++
Identify the relevant levels of resolution for different flows in the ecosphere models		X	X	++
Assess the variations of impacts over different temporal scopes for uncertainty analysis			X	+++
Propose strategies for transparent use of prospective assumptions in the ecosphere models		X	X	+++

5 Conclusions

Considerable efforts have been made in the last 20 years to include temporal considerations within the LCA framework and to show that accounting for such aspects significantly affects the results of, at least, some case studies. For instance, LCA studies on systems with long lifespan (e.g. buildings) can benefit from models and tools where the dynamics of energy flows are considered more details (i.e. variations and evolutions). Periods of validity for datasets, which represent rapidly progressing technologies (e.g. photovoltaic cells), are important temporal information, provided in some LCA databases. Furthermore, dynamic LCIA methods have now been developed to account for impacts that

vary significantly when the timing of emission change. Overall, the suggested approaches, tools and strategies increase the temporal representativeness of LCA studies and decrease the temporal uncertainty of models for systems and impacts. Nevertheless, their uses in current LCA studies are still uncommon, which can be explained by a lack of consistent descriptions and the challenges of gathering temporal information.

With that in mind, we offer some propositions for the next steps of developments in the DLCA framework. A glossary is proposed to build a common and consistent understanding on the key concepts that often come up in discussions on the subject. It should help in the use of the already available information that can be found in LCA databases and studies under different names. The consistent description of this metadata should also simplify the automated exchange of information between different software options and practitioners. Our overview on temporal considerations in the LCI phase suggests that a preferred pathway seems to emerge in the computational approach (i.e. graph search algorithms) for DLCA, but it will require the use of process-relative temporal distributions to describe flows in datasets (i.e. input format). This information should then provide temporal distributions for all elementary flows. The temporal boundaries DLCA (i.e. temporal scope) should aim at being defined within a calendar-based description (e.g. between 1990 and 2020) to improve the potential for representativeness of the impact assessments. A balance between necessary data collection efforts and reduction of uncertainties should define the temporal resolution of such distributions. It will also be important to consider the chosen DLCA methods when selecting the temporal resolutions of flows. Lastly, the current development of the DLCA methods should continue by pursuing the estimation of uncertainty and variability that comes up in all impact categories when temporal information is not provided to describe the input LCI. It is then recommended to identify a relevant level of temporal resolution that would minimise the temporal uncertainty of the models for impact assessments.

References for Paper 4

- [1] Life cycle assessment Requirements and guidelines, I. 14044, 2006 2006.
- [2] Life cycle assessment Principles and framework, I. 14040, 2006 2006.
- [3] J. W. Owens, "Life-Cycle Assessment in Relation to Risk Assessment: An Evolving Perspective," *Risk Analysis*, vol. 17, no. 3, pp. 359-365, 1997 1997, doi: 10.1111/j.1539-6924.1997.tb00874.x.
- [4] J. Reap, F. Roman, S. Duncan, and B. Bras, "A survey of unresolved problems in life cycle assessment - Part 2," *Int. J. of LCA*, vol. 13, no. 5, pp. 374-388, Aug 2008, doi: 10.1007/s11367-008-0009-9.
- [5] G. Finnveden et al., "Recent developments in Life Cycle Assessment," (in English), *J Environ Manage*, vol. 91, pp. 1-21, 2009 Oct 2009, doi: 10.1016/j.jenvman.2009.06.018.
- [6] K. Angelakoglou and G. Gaidajis, "A review of methods contributing to the assessment of the environmental sustainability of industrial systems," *J Clean Prod*, vol. 108, pp. 725-747, Dec 2015, doi: 10.1016/j.jclepro.2015.06.094.
- [7] J. Reap, F. Roman, S. Duncan, and B. Bras, "A survey of unresolved problems in life cycle assessment - Part 1," *Int J Life Cycle Assess*, vol. 13, pp. 290-300, 2008 2008, doi: 10.1007/s11367-008-0008-x.

Appendices

- [8] G. Rebitzer et al., "Life cycle assessment: Part 1: Framework, goal and scope definition, inventory analysis, and applications," *Environ. Int.*, vol. 30, pp. 701-720, 2004, doi: 10.1016/j.envint.2003.11.005.
- [9] C. Yuan, E. D. Wang, Q. Zhai, and F. Yang, "Temporal discounting in life cycle assessment: A critical review and theoretical framework," *Environmental Impact Assessment Review*, vol. 51, pp. 23-31, Feb 2015, doi: 10.1016/j.eiar.2015.01.001.
- [10] A. Levasseur, P. Lesage, M. Margni, L. Deschenes, and R. Samson, "Considering Time in LCA: Dynamic LCA and Its Application to Global Warming Impact Assessments," *Environ. Sci. Technol.*, vol. 44, no. 8, pp. 3169-3174, 2010, doi: 10.1021/es9030003.
- [11] A. Kendall, "Time-adjusted global warming potentials for LCA and carbon footprints," *Int. J. of LCA*, vol. 17, no. 8, pp. 1042-1049, 2012 Sep 2012, doi: 10.1007/s11367-012-0436-5.
- [12] R. Manneh, M. Margni, and L. Deschênes, "Evaluating the relevance of seasonal differentiation of human health intake fractions in life cycle assessment," *Integrated Environmental Assessment and Management*, vol. 8, pp. 749-759, 2012, doi: 10.1002/ieam.1308.
- [13] V. Shah and R. Ries, "A characterization model with spatial and temporal resolution for life cycle impact assessment of photochemical precursors in the United States," *Int J Life Cycle Assess*, vol. 14, pp. 313-327, 2009, doi: 10.1007/s11367-009-0084-6.
- [14] P. Fantke et al., "Parameterization Models for Pesticide Exposure via Crop Consumption," *Environ. Sci. Technol.*, vol. 46, no. 23, pp. 12864-12872, 2012/12/04 2012, doi: 10.1021/es301509u.
- [15] S. Hellweg, "Time- and site-dependent life cycle assessment of thermal waste treatment processes," *Int J Life Cycle Assess*, journal article vol. 6, no. 1, pp. 46-46, 2001, doi: 10.1007/bf02977597.
- [16] A. Levasseur, P. Lesage, M. Margni, and R. Samson, "Biogenic Carbon and Temporary Storage Addressed with Dynamic Life Cycle Assessment," *Journal of Industrial Ecology*, vol. 17, no. 1, pp. 117-128, 2013, doi: 10.1111/j.1530-9290.2012.00503.x.
- [17] W. O. Collinge, A. E. Landis, A. K. Jones, L. A. Schaefer, and M. M. Bilec, "Dynamic life cycle assessment: framework and application to an institutional building," *Int. J. of LCA*, vol. 18, no. 3, pp. 538-552, 2013 Mar 2013, doi: 10.1007/s11367-012-0528-2.
- [18] W. O. Collinge, H. J. Rickenbacker, A. E. Landis, C. L. Thiel, and M. M. Bilec, "Dynamic Life Cycle Assessments of a Conventional Green Building and a Net Zero Energy Building: Exploration of Static, Dynamic, Attributional, and Consequential Electricity Grid Models," *Environ. Sci. Technol.*, vol. 52, no. 19, pp. 11429-11438, 2018/10/02 2018, doi: 10.1021/acs.est.7b06535.
- [19] F. Menten, S. Tchung-Ming, D. Lorne, and F. Bouvart, "Lessons from the use of a long-term energy model for consequential life cycle assessment: The BTL case," *Renewable & Sustainable Energy Reviews*, vol. 43, pp. 942-960, Mar 2015, doi: 10.1016/j.rser.2014.11.072.
- [20] M. B. Amor, C. Gaudreault, P.-O. Pineau, and R. Samson. "Implications of integrating electricity supply dynamics into life cycle assessment: a case study of renewable distributed generation." (accessed).
- [21] C. Roux, P. Schalbart, and B. Peuportier, "Accounting for temporal variation of electricity production and consumption in the LCA of an energy-efficient house," *J Clean Prod*, vol. 113, pp. 532-540, Feb 2016, doi: 10.1016/j.jclepro.2015.11.052.
- [22] K. Negishi, A. Lebert, D. Almeida, J. Chevalier, and L. Tiruta-Barna, "Evaluating climate change pathways through a building's lifecycle based on Dynamic Life Cycle Assessment," *Build Environ*, vol. 164, p. 106377, 2019/10/15/ 2019, doi: <https://doi.org/10.1016/j.buildenv.2019.106377>.
- [23] D. Beloin-Saint-Pierre, A. Levasseur, M. Margni, and I. Blanc, "Implementing a Dynamic Life Cycle Assessment Methodology with a Case Study on Domestic Hot Water Production," (in en), *Journal of Industrial Ecology*, 2017, doi: 10.1111/jiec.12499.
- [24] P. Fantke et al., "Toward harmonizing ecotoxicity characterization in life cycle impact assessment," *Environmental Toxicology and Chemistry*, vol. 37, no. 12, pp. 2955-2971, 2018/12/01 2018, doi: 10.1002/etc.4261.
- [25] EC-JRC, *ILCD Handbook - General Guide for Life Cycle Assessment - Detailed Guidance*. Luxembourg: Publication office of the european union, 2010, p. 394.

- [26] B. P. Weidema, J. Schmidt, P. Fantke, and S. Pauliuk, "On the boundary between economy and environment in life cycle assessment," *Int J Life Cycle Assess*, vol. 23, no. 9, pp. 1839-1846, 2018/09/01 2018, doi: 10.1007/s11367-017-1398-4.
- [27] C. K. Anand and B. Amor, "Recent developments, future challenges and new research directions in LCA of buildings: A critical review," *Renewable & Sustainable Energy Reviews*, vol. 67, pp. 408-416, Jan 2017, doi: 10.1016/j.rser.2016.09.058.
- [28] H. AzariJafari, A. Yahia, and M. Ben Amor, "Life cycle assessment of pavements: reviewing research challenges and opportunities," *J Clean Prod*, vol. 112, pp. 2187-2197, Jan 2016, doi: 10.1016/j.jclepro.2015.09.080.
- [29] J. J. Fitzpatrick, "Environmental sustainability assessment of using forest wood for heat energy in Ireland," *Renewable & Sustainable Energy Reviews*, vol. 57, pp. 1287-1295, May 2016, doi: 10.1016/j.rser.2015.12.197.
- [30] T. Helin, L. Sokka, S. Soimakallio, K. Pingoud, and T. Pajula, "Approaches for inclusion of forest carbon cycle in life cycle assessment - a review," *Global Change Biology Bioenergy*, vol. 5, no. 5, pp. 475-486, Sep 2013, doi: 10.1111/gcbb.12016.
- [31] A. Mehmeti, S. J. McPhail, D. Pumiglia, and M. Carlini, "Life cycle sustainability of solid oxide fuel cells: From methodological aspects to system implications," *Journal of Power Sources*, vol. 325, pp. 772-785, Sep 2016, doi: 10.1016/j.jpowsour.2016.06.078.
- [32] J. Pettersen and E. G. Hertwich, "Critical review: Life-cycle inventory procedures for long-term release of metals," *Environ. Sci. Technol.*, vol. 42, no. 13, pp. 4639-4647, Jul 2008, doi: 10.1021/es702170v.
- [33] O. Jolliet, M. Saadé, P. Crettaz, and S. Shaked, *Analyse du cycle de vie - Comprendre et réaliser un écobilan*, 2e édition ed. EPFL - Lausanne - Suisse: Presses polytechniques et universitaires romandes, 2010, p. 312.
- [34] E. 15978, "Assessment of environmental performance of buildings Calculation method," in "Sustainability of construction works," 2009 2009.
- [35] M. Fouquet et al., "Methodological challenges and developments in LCA of low energy buildings: Application to biogenic carbon and global warming assessment," *Build Environ*, vol. 90, pp. 51-59, Aug 2015, doi: 10.1016/j.buildenv.2015.03.022.
- [36] C. Breton, P. Blanchet, B. Amor, R. Beauregard, and W.-S. Chang, "Assessing the Climate Change Impacts of Biogenic Carbon in Buildings: A Critical Review of Two Main Dynamic Approaches," *Sustainability*, vol. 10, no. 6, 2018, doi: 10.3390/su10062020.
- [37] C. L. Huang, J. Vause, H. W. Ma, and C. P. Yu, "Using material/substance flow analysis to support sustainable development assessment: A literature review and outlook," *Resources Conservation and Recycling*, vol. 68, pp. 104-116, Nov 2012, doi: 10.1016/j.resconrec.2012.08.012.
- [38] J. Ling-Chin, O. Heidrich, and A. P. Roskilly, "Life cycle assessment (LCA) - from analysing methodology development to introducing an LCA framework for marine photovoltaic (PV) systems," *Renewable & Sustainable Energy Reviews*, vol. 59, pp. 352-378, Jun 2016, doi: 10.1016/j.rser.2015.12.058.
- [39] N. Santero, A. Loijos, M. Akbarian, and J. Ochsendorf, "Methos, Impacts, and Opportunities in the Concrete Pavement Life Cycle," MIT, USA, 2011-8 2011.
- [40] P. Inyim, J. Pereyra, M. Bienvenu, and A. Mostafavi, "Environmental assessment of pavement infrastructure: A systematic review," *J Environ Manage*, vol. 176, pp. 128-138, Jul 2016, doi: 10.1016/j.jenvman.2016.03.042.
- [41] S. J. Kim, S. Kara, and M. Hauschild, "Functional unit and product functionality—addressing increase in consumption and demand for functionality in sustainability assessment with LCA," *Int J Life Cycle Assess*, journal article vol. 22, no. 8, pp. 1257-1265, August 01 2017, doi: 10.1007/s11367-016-1233-3.
- [42] C. Bessou, C. Basset-Mens, T. Tran, and A. Benoist, "LCA applied to perennial cropping systems: a review focused on the farm stage," *Int. J. of LCA*, vol. 18, no. 2, pp. 340-361, Feb 2013, doi: 10.1007/s11367-012-0502-z.

Appendices

- [43] G. Wernet, C. Bauer, B. Steubing, J. Reinhard, E. Moreno-Ruiz, and B. Weidema, "The ecoinvent database version 3 (part I): overview and methodology," (in en), *Int J Life Cycle Assess*, vol. 21, pp. 1218-1230, 2016/04/21 2016, doi: 10.1007/s11367-016-1087-8.
- [44] A. A. W. Karl, E. Maslesa, and M. Birkved, "Environmental performance assessment of the use stage of buildings using dynamic high-resolution energy consumption and data on grid composition," *Build Environ*, vol. 147, pp. 97-107, 2019/01/01/ 2019, doi: <https://doi.org/10.1016/j.buildenv.2018.09.042>.
- [45] D. Vuarnoz et al., "Integrating hourly life-cycle energy and carbon emissions of energy supply in buildings," *Sustainable Cities and Society*, vol. 43, pp. 305-316, 2018/11/01/ 2018, doi: <https://doi.org/10.1016/j.scs.2018.08.026>.
- [46] J. L. Sohn, P. P. Kalbar, G. T. Banta, and M. Birkved, "Life-cycle based dynamic assessment of mineral wool insulation in a Danish residential building application," *J Clean Prod*, vol. 142, pp. 3243-3253, 2017/01/20/ 2017, doi: <https://doi.org/10.1016/j.jclepro.2016.10.145>.
- [47] C. Roux, P. Schalbart, and B. Peuportier, "Development of an electricity system model allowing dynamic and marginal approaches in LCA—tested in the French context of space heating in buildings," *Int J Life Cycle Assess*, vol. 22, no. 8, pp. 1177-1190, 2017/08/01 2017, doi: 10.1007/s11367-016-1229-z.
- [48] M. Fouquet et al., "Methodological challenges and developments in LCA of low energy buildings: Application to biogenic carbon and global warming assessment," *Build Environ*, vol. 90, pp. 51-59, 2015/08/01/ 2015, doi: <https://doi.org/10.1016/j.buildenv.2015.03.022>.
- [49] H. Fernandez-Mena, T. Nesme, and S. Pellerin, "Towards an Agro-Industrial Ecology: A review of nutrient flow modelling and assessment tools in agro-food systems at the local scale," *Science of the Total Environment*, vol. 543, pp. 467-479, Feb 2016, doi: 10.1016/j.scitotenv.2015.11.032.
- [50] N. Heeren, M. Jakob, G. Martius, N. Gross, and H. Wallbaum, "A component based bottom-up building stock model for comprehensive environmental impact assessment and target control," *Renewable & Sustainable Energy Reviews*, vol. 20, pp. 45-56, Apr 2013, doi: 10.1016/j.rser.2012.11.064.
- [51] G. G. Zaimes, N. Vora, S. S. Chopra, A. E. Landis, and V. Khanna, "Design of Sustainable Biofuel Processes and Supply Chains: Challenges and Opportunities," *Processes*, vol. 3, no. 3, pp. 634-663, Sep 2015, doi: 10.3390/pr3030634.
- [52] C. Bessou, F. Ferchaud, B. Gabrielle, and B. Mary, "Biofuels, greenhouse gases and climate change. A review," *Agronomy for Sustainable Development*, vol. 31, no. 1, pp. 1-79, Jan 2011, doi: 10.1051/agro/2009039.
- [53] S. Jeffery et al., "The way forward in biochar research: targeting trade-offs between the potential wins," *Global Change Biology Bioenergy*, vol. 7, no. 1, pp. 1-13, Jan 2015, doi: 10.1111/gcbb.12132.
- [54] M. Roder and P. Thornley, "Bioenergy as climate change mitigation option within a 2 degrees C target-uncertainties and temporal challenges of bioenergy systems," *Energy Sustainability and Society*, vol. 6, Mar 2016, Art no. 6, doi: 10.1186/s13705-016-0070-3.
- [55] K. R. Caffrey and M. W. Veal, "Conducting an Agricultural Life Cycle Assessment: Challenges and Perspectives," *Scientific World Journal*, 2013, Art no. 472431, doi: 10.1155/2013/472431.
- [56] S. D. R. Pahri, A. F. Mohamed, and A. Samat, "LCA for open systems: a review of the influence of natural and anthropogenic factors on aquaculture systems," *Int. J. of LCA*, vol. 20, no. 9, pp. 1324-1337, Sep 2015, doi: 10.1007/s11367-015-0929-0.
- [57] M. Recchioni, F. Mathieux, M. Goralczyk, and E. M. Schau, "ILCD Data Network and ELCD Database: current use and further needs for supporting Environmental Footprint and Life Cycle Indicator Projects," Joint Research Centre, Ispra, Italy, 2013.
- [58] B. Weidema et al., "Overview and methodology. Data quality guideline for the ecoinvent database version 3.," in "Ecoinvent Report," The ecoinvent Centre, St. Gallen: The ecoinvent Centre, 2012 2012.
- [59] O. Arodudu, K. Helming, H. Wiggering, and A. Voinov, "Towards a more holistic sustainability assessment framework for agro-bioenergy systems - A review," *Environmental Impact Assessment Review*, vol. 62, pp. 61-75, Jan 2017, doi: 10.1016/j.eiar.2016.07.008.

- [60] R. B. Chowdhury, G. A. Moore, A. J. Weatherley, and M. Arora, "Key sustainability challenges for the global phosphorus resource, their implications for global food security, and options for mitigation," *J Clean Prod*, vol. 140, pp. 945-963, Jan 2017, doi: 10.1016/j.jclepro.2016.07.012.
- [61] T. Dandres, C. Gaudreault, P. Tirado-Seco, and R. Samson, "Macroanalysis of the economic and environmental impacts of a 2005-2025 European Union bioenergy policy using the GTAP model and life cycle assessment," *Renewable & Sustainable Energy Reviews*, vol. 16, no. 2, pp. 1180-1192, Feb 2012, doi: 10.1016/j.rser.2011.11.003.
- [62] Y. B. Moon, "Simulation modelling for sustainability: a review of the literature," *International Journal of Sustainable Engineering*, vol. 10, no. 1, pp. 2-19, 2017, doi: 10.1080/19397038.2016.1220990.
- [63] S. A. Morais and C. Delerue-Matos, "A perspective on LCA application in site remediation services: Critical review of challenges," *Journal of Hazardous Materials*, vol. 175, no. 1-3, pp. 12-22, Mar 2010, doi: 10.1016/j.jhazmat.2009.10.041.
- [64] A. Pinsonnault, P. Lesage, A. Levasseur, and R. Samson, "Temporal differentiation of background systems in LCA: relevance of adding temporal information in LCI databases," (in en), *Int J Life Cycle Assess*, vol. 19, no. 11, pp. 1843-1853, 2014/07/19 2014, doi: 10.1007/s11367-014-0783-5.
- [65] F. Lebailly, A. Levasseur, R. Samson, and L. Deschenes, "Development of a dynamic LCA approach for the freshwater ecotoxicity impact of metals and application to a case study regarding zinc fertilization," *Int. J. of LCA*, vol. 19, no. 10, pp. 1745-1754, Oct 2014, doi: 10.1007/s11367-014-0779-1.
- [66] C. Roux, P. Schalbart, E. Assoumou, and B. Peuportier, "Integrating climate change and energy mix scenarios in LCA of buildings and districts," *Applied Energy*, vol. 184, pp. 619-629, 2016/12/15/ 2016, doi: <https://doi.org/10.1016/j.apenergy.2016.10.043>.
- [67] L. Tiruta-Barna, Y. Pigne, T. N. Gutierrez, and E. Benetto, "Framework and computational tool for the consideration of time dependency in Life Cycle Inventory: proof of concept," *J Clean Prod*, vol. 116, pp. 198-206, Mar 2016, doi: 10.1016/j.jclepro.2015.12.049.
- [68] G. Cardellini, C. L. Mutel, E. Vial, and B. Muys, "Temporalis, a generic method and tool for dynamic Life Cycle Assessment," *Science of The Total Environment*, vol. 645, pp. 585-595, 2018/12/15/ 2018, doi: <https://doi.org/10.1016/j.scitotenv.2018.07.044>.
- [69] P. Alstone, P. Lai, E. Mills, and A. Jacobson, "High Life Cycle Efficacy Explains Fast Energy Payback for Improved Off-Grid Lighting Systems," *Journal of Industrial Ecology*, vol. 18, no. 5, pp. 722-733, Oct 2014, doi: 10.1111/jiec.12117.
- [70] P. M. F. Elshout et al., "Greenhouse-gas payback times for crop-based biofuels," (in en), *Nature Climate Change*, vol. 5, pp. 604-610, 2015-05-11 2015, doi: doi:10.1038/nclimate2642.
- [71] N. Espinosa, M. Hösel, D. Angmo, and F. C. Krebs, "Solar cells with one-day energy payback for the factories of the future," (in en), *Energy & Environmental Science*, vol. 5, pp. 5117-5132, 2012/01/01 2012, doi: 10.1039/C1EE02728J.
- [72] V. Fthenakis and E. Alsema, "Photovoltaics energy payback times, greenhouse gas emissions and external costs: 2004 - early 2005 status," *Progress in Photovoltaics*, vol. 14, pp. 275-280, 2006 2006, doi: 10.1002/pp.706.
- [73] M. Goe and G. Gaustad, "Strengthening the case for recycling photovoltaics: An energy payback analysis," *Applied Energy*, vol. 120, pp. 41-48, May 2014, doi: 10.1016/j.apenergy.2014.01.036.
- [74] K. Knapp and T. Jester, "Empirical investigation of the energy payback time for photovoltaic modules," (in English), *Solar Energy*, vol. 71, pp. 165-172, 2001 2001.
- [75] S. Hellweg, T. B. Hofstetter, and K. Hungerbühler, "Discounting and the environment - Should current impacts be weighted differently than impacts harming future generations?," *Int. J. of LCA*, vol. 8, no. 1, pp. 8-18, 2003, doi: 10.1065/lca2002.09.097.
- [76] Y. Pigné et al., "A tool to operationalize dynamic LCA, including time differentiation on the complete background database," *Int J Life Cycle Assess*, journal article November 05 2019, doi: 10.1007/s11367-019-01696-6.

Appendices

- [77] C. W. Tessum, J. D. Marshall, and J. D. Hill, "A Spatially and Temporally Explicit Life Cycle Inventory of Air Pollutants from Gasoline and Ethanol in the United States," *Environ. Sci. Technol.*, vol. 46, pp. 11408-11417, 2012 Oct 16 2012, doi: 10.1021/es3010514.
- [78] Y. Yang and S. Suh, "Changes in environmental impacts of major crops in the US," *Environ Res Lett.*, vol. 10, no. 9, Sep 2015, Art no. 094016, doi: 10.1088/1748-9326/10/9/094016.
- [79] I. Bakas, M. Z. Hauschild, T. F. Astrup, and R. K. Rosenbaum, "Preparing the ground for an operational handling of long-term emissions in LCA," *Int. J. of LCA*, vol. 20, no. 10, pp. 1444-1455, Oct 2015, doi: 10.1007/s11367-015-0941-4.
- [80] D. Vuarnoz and T. Jusselme, "Temporal variations in the primary energy use and greenhouse gas emissions of electricity provided by the Swiss grid," *Energy*, vol. 161, pp. 573-582, 2018/10/15/ 2018, doi: <https://doi.org/10.1016/j.energy.2018.07.087>.
- [81] D. Beloin-Saint-Pierre, P. Padey, B. Périsset, and V. Medici, "Considering the dynamics of electricity demand and production for the environmental benchmark of Swiss residential buildings that exclusively use electricity," *IOP Conference Series: Earth and Environmental Science*, vol. 323, p. 012096, 2019/09/06 2019, doi: 10.1088/1755-1315/323/1/012096.
- [82] P. Collet, A. Hélias, L. Lardon, and J.-P. Steyer, "Time and Life Cycle Assessment: How to Take Time into Account in the Inventory Step?," in *Towards Life Cycle Sustainability Management*, M. Finkbeiner Ed. Dordrecht: Springer Netherlands, 2011, pp. 119-130.
- [83] D. Beloin-Saint-Pierre, R. Heijungs, and I. Blanc, "The ESPA (Enhanced Structural Path Analysis) method: a solution to an implementation challenge for dynamic life cycle assessment studies," (in en), *Int J Life Cycle Assess*, vol. 19, no. 4, pp. 861-871, 2014/02/04 2014, doi: 10.1007/s11367-014-0710-9.
- [84] E. Risch et al., "Impacts from urban water systems on receiving waters – How to account for severe wet-weather events in LCA?," *Water Research*, vol. 128, pp. 412-423, 2018/01/01/ 2018, doi: <https://doi.org/10.1016/j.watres.2017.10.039>.
- [85] P. Zhai and E. D. Williams, "Dynamic Hybrid Life Cycle Assessment of Energy and Carbon of Multicrystalline Silicon Photovoltaic Systems," (in English), *Environ. Sci. Technol.*, vol. 44, no. 20, pp. 7950-7955, 2010 Oct 2010, doi: 10.1021/es1026695.
- [86] M. Pehnt, "Dynamic life cycle assessment (LCA) of renewable energy technologies," *Renewable Energy*, vol. 31, no. 1, pp. 55-71, 2006 2006, doi: 10.1016/j.renene.2005.03.002.
- [87] S. Frijia, S. Guhathakurta, and E. Williams, "Functional Unit, Technological Dynamics, and Scaling Properties for the Life Cycle Energy of Residences," *Environ. Sci. Technol.*, vol. 46, no. 3, pp. 1782-1788, 2012/02/07 2012, doi: 10.1021/es202202q.
- [88] S. Su, X. Li, Y. Zhu, and B. Lin, "Dynamic LCA framework for environmental impact assessment of buildings," *Energy and Buildings*, vol. 149, no. Supplement C, pp. 310-320, 2017/08/15/ 2017, doi: <https://doi.org/10.1016/j.enbuild.2017.05.042>.
- [89] C. Scheuer, G. A. Keoleian, and P. Reppe, "Life cycle energy and environmental performance of a new university building: modeling challenges and design implications," *Energy and Buildings*, vol. 35, no. 10, pp. 1049-1064, Nov 2003, doi: 10.1016/s0378-7788(03)00066-5.
- [90] W. Collinge, A. E. Landis, A. K. Jones, L. A. Schaefer, and M. M. Bilec, "Indoor environmental quality in a dynamic life cycle assessment framework for whole buildings: Focus on human health chemical impacts," *Build Environ*, vol. 62, pp. 182-190, Apr 2013, doi: 10.1016/j.buildenv.2013.01.015.
- [91] P. Pawelzik et al., "Critical aspects in the life cycle assessment (LCA) of bio-based materials – Reviewing methodologies and deriving recommendations," *Resources, Conservation and Recycling*, vol. 73, pp. 211-228, 2013/04/01/ 2013, doi: <http://dx.doi.org/10.1016/j.resconrec.2013.02.006>.
- [92] C. Bauer, J. Hofer, H.-J. Althaus, A. Del Duce, and A. Simons, "The environmental performance of current and future passenger vehicles: Life cycle assessment based on a novel scenario analysis framework," *Applied Energy*, vol. 157, pp. 871-883, 2015/11/01/ 2015, doi: <http://dx.doi.org/10.1016/j.apenergy.2015.01.019>.

- [93] M. Miotti, J. Hofer, and C. Bauer, "Integrated environmental and economic assessment of current and future fuel cell vehicles," *Int J Life Cycle Assess*, journal article vol. 22, no. 1, pp. 94-110, 2017, doi: 10.1007/s11367-015-0986-4.
- [94] A. Simons and C. Bauer, "A life-cycle perspective on automotive fuel cells," *Applied Energy*, vol. 157, pp. 884-896, 2015/11/01/ 2015, doi: <http://dx.doi.org/10.1016/j.apenergy.2015.02.049>.
- [95] R. Mendivil, U. Fischer, M. Hirao, and K. Hungerbühler, "A New LCA Methodology of Technology Evolution (TE-LCA) and its Application to the Production of Ammonia (1950-2000) (8 pp)," *Int J Life Cycle Assess*, journal article vol. 11, no. 2, pp. 98-105, March 01 2006, doi: 10.1065/lca2005.08.222.
- [96] G. Herfray and B. Peuportier, "Evaluation of Electricity Related Impacts Using a Dynamic LCA Model," in *International Symposium on Life Cycle Assessment and Construction*, A. Ventura and C. de la Roche, Eds., 2012 2012: RILEM, pp. 300-308.
- [97] M. Pehnt, "Assessing future energy and transport systems: The case of fuel cells Part I: Methodological aspects," *Int. J. of LCA*, vol. 8, no. 5, pp. 283-289, 2003, doi: 10.1065/lca2003.07.128.
- [98] M. Pehnt, "Assessing future energy and transport systems: The case of fuel cells - Part 2: Environmental performance," *Int. J. of LCA*, vol. 8, no. 6, pp. 365-378, 2003, doi: 10.1065/lca2003.10.135.
- [99] N. H. Sandberg and H. Brattebø, "Analysis of energy and carbon flows in the future Norwegian dwelling stock," *Building Research & Information*, vol. 40, no. 2, pp. 123-139, 2012/04/01 2012, doi: 10.1080/09613218.2012.655071.
- [100] A. Albers, P. Collet, D. Lorne, A. Benoist, and A. Hélias, "Coupling partial-equilibrium and dynamic biogenic carbon models to assess future transport scenarios in France," *Applied Energy*, vol. 239, pp. 316-330, 2019/04/01/ 2019, doi: <https://doi.org/10.1016/j.apenergy.2019.01.186>.
- [101] A. Marvuglia, E. Benetto, S. Rege, and C. Jury, "Modelling approaches for consequential life-cycle assessment (C-LCA) of bioenergy: Critical review and proposed framework for biogas production," *Renewable and Sustainable Energy Reviews*, vol. 25, no. C, pp. 768-781, 2013, doi: 10.1016/j.rser.2013.05.01.
- [102] T. Dandres, C. Gaudreault, P. Tirado-Seco, and R. Samson, "Assessing non-marginal variations with consequential LCA: Application to European energy sector," *Renewable and Sustainable Energy Reviews*, vol. 15, no. 6, pp. 3121-3132, 2011/08/01/ 2011, doi: <https://doi.org/10.1016/j.rser.2011.04.004>.
- [103] E. Igos, B. Rugani, S. Rege, E. Benetto, L. Drouet, and D. S. Zachary, "Combination of equilibrium models and hybrid life cycle-input-output analysis to predict the environmental impacts of energy policy scenarios," *Applied Energy*, vol. 145, pp. 234-245, 2015/05/01/ 2015, doi: <https://doi.org/10.1016/j.apenergy.2015.02.007>.
- [104] A. Marvuglia, M. Kanevski, and E. Benetto, "Machine learning for toxicity characterization of organic chemical emissions using USEtox database: Learning the structure of the input space," *Environ. Int.*, vol. 83, pp. 72-85, 2015/10/01/ 2015, doi: <https://doi.org/10.1016/j.envint.2015.05.011>.
- [105] F. Querini and E. Benetto, "Combining Agent-Based Modeling and Life Cycle Assessment for the Evaluation of Mobility Policies," *Environ. Sci. Technol.*, vol. 49, no. 3, pp. 1744-1751, 2015/02/03 2015, doi: 10.1021/es5060868.
- [106] M. Noori and O. Tatari, "Development of an agent-based model for regional market penetration projections of electric vehicles in the United States," *Energy*, vol. 96, no. C, pp. 215-230, 2016, doi: DOI: 10.1016/j.energy.2015.12.018.
- [107] S. A. Miller, S. Moysey, B. Sharp, and J. Alfaro, "A Stochastic Approach to Model Dynamic Systems in Life Cycle Assessment," *Journal of Industrial Ecology*, vol. 17, no. 3, pp. 352-362, Jun 2013, doi: 10.1111/j.1530-9290.2012.00531.x.
- [108] C. Knoeri, P. A. Waeger, A. Stamp, H. J. Althaus, and M. Weil, "Towards a dynamic assessment of raw materials criticality: Linking agent-based demand - With material flow supply modelling approaches," *Science of the Total Environment*, vol. 461, pp. 808-812, Sep 2013, doi: 10.1016/j.scitotenv.2013.02.001.
- [109] S. Hellweg, T. B. Hofstetter, and K. Hungerbühler, "Time-dependent life-cycle assessment of slag landfills with the help of scenario analysis: the example of Cd and Cu," *J Clean Prod*, vol. 13, no. 3, pp. 301-320, 2005/02/01/ 2005, doi: <https://doi.org/10.1016/j.jclepro.2004.02.016>.

Appendices

- [110] S. Pfister, P. Bayer, A. Koehler, and S. Hellweg, "Projected water consumption in future global agriculture: Scenarios and related impacts," *Science of The Total Environment*, vol. 409, no. 20, pp. 4206-4216, 2011/09/15/ 2011, doi: <https://doi.org/10.1016/j.scitotenv.2011.07.019>.
- [111] J. K. Choi, P. Friley, and T. Alfstad, "Implications of energy policy on a product system's dynamic life-cycle environmental impact: Survey and model," *Renewable & Sustainable Energy Reviews*, vol. 16, no. 7, pp. 4744-4752, Sep 2012, doi: [10.1016/j.rser.2012.05.032](https://doi.org/10.1016/j.rser.2012.05.032).
- [112] E. Igos et al., "Integrated environmental assessment of future energy scenarios based on economic equilibrium models," *Metallurgical Research & Technology*, vol. 111, no. 3, pp. 179-189, 2014, doi: [10.1051/metal/2014024](https://doi.org/10.1051/metal/2014024).
- [113] J. M. Earles, A. Halog, P. Ince, and K. Skog, "Integrated Economic Equilibrium and Life Cycle Assessment Modeling for Policy-based Consequential LCA," *Journal of Industrial Ecology*, vol. 17, no. 3, pp. 375-384, 2013, doi: [10.1111/j.1530-9290.2012.00540.x](https://doi.org/10.1111/j.1530-9290.2012.00540.x).
- [114] H. E. Daly, K. Scott, N. Strachan, and J. Barrett, "Indirect CO2 Emission Implications of Energy System Pathways: Linking IO and TIMES Models for the UK," *Environ. Sci. Technol.*, vol. 49, no. 17, pp. 10701-10709, 2015/09/01 2015, doi: [10.1021/acs.est.5b01020](https://doi.org/10.1021/acs.est.5b01020).
- [115] E. G. Hertwich et al., "Integrated life-cycle assessment of electricity-supply scenarios confirms global environmental benefit of low-carbon technologies," (in en), 2015-05-19 2015, doi: [10.1073/pnas.1312753111](https://doi.org/10.1073/pnas.1312753111).
- [116] J. P. Alvarez-Gaitan, M. D. Short, G. M. Peters, I. MacGill, and S. Moore, "Consequential cradle-to-gate carbon footprint of water treatment chemicals using simple and complex marginal technologies for electricity supply," *Int J Life Cycle Assess*, journal article vol. 19, no. 12, pp. 1974-1984, December 01 2014, doi: [10.1007/s11367-014-0799-x](https://doi.org/10.1007/s11367-014-0799-x).
- [117] H.-L. Pesonen et al., "Framework for scenario development in LCA," (in en), *Int J Life Cycle Assess*, vol. 5, p. 21, 2000/01/01 2000, doi: [10.1007/BF02978555](https://doi.org/10.1007/BF02978555).
- [118] R. Heijungs and S. Suh, *The Computational Structure of Life Cycle Assessment, First ed. (ECO-EFFICIENCY IN INDUSTRY AND SCIENCE)*. Dordrecht, The Netherlands: Kluwer Academic, 2002, p. 241.
- [119] W. O. Collinge et al., "Measuring Whole-Building Performance with Dynamic LCA: a Case Study of a Green University Building," in *International Symposium on Life Cycle Assessment and Construction*, A. Ventura and C. de la Roche, Eds., 2012 2012: RILEM, pp. 309-317.
- [120] M. Maier, M. Mueller, and X. Y. Yan, "Introducing a localised spatio-temporal LCI method with wheat production as exploratory case study," *J Clean Prod*, vol. 140, pp. 492-501, Jan 2017, doi: [10.1016/j.jclepro.2016.07.160](https://doi.org/10.1016/j.jclepro.2016.07.160).
- [121] A. H. Shimako, L. Tiruta-Barna, A. B. Bisinella de Faria, A. Ahmadi, and M. Spérandio, "Sensitivity analysis of temporal parameters in a dynamic LCA framework," *Science of The Total Environment*, vol. 624, pp. 1250-1262, 2018/05/15/ 2018, doi: <https://doi.org/10.1016/j.scitotenv.2017.12.220>.
- [122] A. H. Shimako et al., "Environmental assessment of bioenergy production from microalgae based systems," *J Clean Prod*, vol. 139, pp. 51-60, Dec 2016, doi: [10.1016/j.jclepro.2016.08.003](https://doi.org/10.1016/j.jclepro.2016.08.003).
- [123] A. H. Shimako, L. Tiruta-Barna, and A. Ahmadi, "Operational integration of time dependent toxicity impact category in dynamic LCA," *Science of The Total Environment*, vol. 599-600, pp. 806-819, 2017/12/01/ 2017, doi: <https://doi.org/10.1016/j.scitotenv.2017.04.211>.
- [124] C. Mutel, "Brightway: An open source framework for Life Cycle Assessment," *Journal of Open Source Software*, vol. 2, no. 12, p. 236, 2017, doi: [doi:10.21105/joss.00236](https://doi.org/10.21105/joss.00236).
- [125] IPCC, "Climate Change 2013: The Physical Science Basis. Contribution of Working Group I to the Fifth Assessment Report of the Intergovernmental Panel on Climate Change," IPCC, Cambridge, United Kingdom and New York, NY, USA, 2013.
- [126] F. Cherubini, G. Guest, and A. H. Stromman, "Application of probability distributions to the modeling of biogenic CO2 fluxes in life cycle assessment," *Global Change Biology Bioenergy*, vol. 4, no. 6, pp. 784-798, Nov 2012, doi: [10.1111/j.1757-1707.2011.01156.x](https://doi.org/10.1111/j.1757-1707.2011.01156.x).

- [127] F. Cherubini, G. P. Peters, T. Berntsen, A. H. Strømman, and E. Hertwich, "CO₂ emissions from biomass combustion for bioenergy: atmospheric decay and contribution to global warming," *GCB Bioenergy*, vol. 3, no. 5, pp. 413-426, 2011, doi: 10.1111/j.1757-1707.2011.01102.x.
- [128] K. P. Shine, "The global warming potential—the need for an interdisciplinary retrieval," *Climatic Change*, journal article vol. 96, no. 4, pp. 467-472, October 01 2009, doi: 10.1007/s10584-009-9647-6.
- [129] J. G. Vogtländer, N. M. van der Velden, and P. van der Lugt, "Carbon sequestration in LCA, a proposal for a new approach based on the global carbon cycle; cases on wood and on bamboo," *Int J Life Cycle Assess*, journal article vol. 19, no. 1, pp. 13-23, January 01 2014, doi: 10.1007/s11367-013-0629-6.
- [130] P. M. Fearnside, "Time preference in global warming calculations: a proposal for a unified index," *Ecological Economics*, vol. 41, no. 1, pp. 21-31, 2002/04/01/ 2002, doi: [http://dx.doi.org/10.1016/S0921-8009\(02\)00004-6](http://dx.doi.org/10.1016/S0921-8009(02)00004-6).
- [131] M. Brandao and A. Levasseur, *Assessing Temporary Carbon Storage in Life Cycle Assessment and Carbon Footprinting: Outcomes of an expert workshop*. Luxembourg: Joint Research Centre - Institute for Environment and Sustainability, 2011, p. 78.
- [132] A. Levasseur et al., "Valuing temporary carbon storage," *Nature Clim. Change*, vol. 2, pp. 6-8, 2012 2012, doi: 10.1038/nclimate1335.
- [133] Specification for the assessment of the life cycle greenhouse gas emissions of goods and services, 2011.
- [134] EC-JRC, *ILCD handbook: Recommendations for Life Cycle Impact Assessment in the European context*. Luxembourg: EC-JRC, 2011.
- [135] M. A. J. Huijbregts et al., "ReCiPe2016. A harmonized life cycle impact assessment method at midpoint and endpoint level," National Institute for Public Health and the Environment, Nijmegen, 2016. [Online]. Available: http://www.rivm.nl/en/Documents_and_publications/Scientific/Reports/2016/december/ReCiPe_2016_A_harmonized_life_cycle_impact_assessment_method_at_midpoint_and_endpoint_level_Report_I_Characterization
- [136] P. Hofstetter, T. Baumgartner, and R. W. Scholz, "Modelling the valuesphere and the ecosphere: Integrating the decision makers' perspectives into LCA," *Int J Life Cycle Assess*, vol. 5, no. 3, p. 161, 2000/05/01 2000, doi: 10.1007/BF02978618.
- [137] A. Benoist, "Adapting Life-Cycle Assessment to biofuels: some elements from the first generation case," *École Nationale Supérieure des Mines de Paris*, 2009. [Online]. Available: <https://pastel.archives-ouvertes.fr/pastel-00005919>
- [138] R. K. Rosenbaum et al., "The Glasgow consensus on the delineation between pesticide emission inventory and impact assessment for LCA," *Int J Life Cycle Assess*, vol. 20, no. 6, pp. 765-776, 2015/06/01 2015, doi: 10.1007/s11367-015-0871-1.
- [139] S. Hellweg and R. Frischknecht, "Evaluation of Long-Term Impacts in LCA," presented at the 22nd Discussion Forum on LCA, Zurich, 2004.
- [140] S. V. Jørgensen, M. Z. Hauschild, and P. H. Nielsen, "The potential contribution to climate change mitigation from temporary carbon storage in biomaterials," *Int J Life Cycle Assess*, journal article vol. 20, no. 4, pp. 451-462, April 01 2015, doi: 10.1007/s11367-015-0845-3.
- [141] P. Fantke and O. Jolliet, "Life cycle human health impacts of 875 pesticides," *Int. J. of LCA*, vol. 21, no. 5, pp. 722-733, May 2016, doi: 10.1007/s11367-015-0910-y.
- [142] N. Peña, M. T. Knudsen, P. Fantke, A. Antón, and J. E. Hermansen, "Freshwater ecotoxicity assessment of pesticide use in crop production: Testing the influence of modeling choices," *J Clean Prod*, vol. 209, pp. 1332-1341, 2019/02/01/ 2019, doi: <https://doi.org/10.1016/j.jclepro.2018.10.257>.
- [143] G. Myhre et al., "Anthropogenic and Natural Radiative Forcing," in *Climate Change 2013: The Physical Science Basis. Contribution of Working Group I to the Fifth Assessment Report of the Intergovernmental Panel on Climate Change* [Stocker, T.F., D. Qin, G.-K. Plattner, M. Tignor, S.K. Allen, J. Boschung, A. Nauels, Y. Xia, V. Bex and P.M. Midgley (eds.)], IPCC Ed. Cambridge, United Kingdom and New York, NY, USA: IPCC, 2013, ch. 8, pp. 659-740.

Appendices

- [144] M. Owsianiak, P. E. Holm, P. Fantke, K. S. Christiansen, O. K. Borggaard, and M. Z. Hauschild, "Assessing comparative terrestrial ecotoxicity of Cd, Co, Cu, Ni, Pb, and Zn: The influence of aging and emission source," *Environmental Pollution*, vol. 206, pp. 400-410, 2015/11/01/ 2015, doi: <https://doi.org/10.1016/j.envpol.2015.07.025>.
- [145] M. O'Hare, R. J. Plevin, J. I. Martin, A. D. Jones, A. Kendall, and E. Hopson, "Proper accounting for time increases crop-based biofuels' greenhouse gas deficit versus petroleum," (in en), *Environ Res Lett.*, vol. 4, p. 024001, 2009-04-01 2009, doi: 10.1088/1748-9326/4/2/024001.
- [146] A. Levasseur et al., "Enhancing life cycle impact assessment from climate science: Review of recent findings and recommendations for application to LCA," *Ecol Indic.*, vol. 71, pp. 163-174, 2016/12/01/ 2016, doi: <http://dx.doi.org/10.1016/j.ecolind.2016.06.049>.
- [147] M. A. J. Huijbregts, J. B. Guinee, and L. Reijnders, "Priority assessment of toxic substances in life cycle assessment. III: Export of potential impact over time and space," (in English), *Chemosphere*, vol. 44, no. 1, pp. 59-65, 2001 Jul 2001, doi: 10.1016/s0045-6535(00)00349-0.
- [148] M. Z. Hauschild, J. Potting, O. Hertel, W. Schopp, and A. Bastrup-Birk, "Spatial differentiation in the characterisation of photochemical ozone formation - The EDIP2003 methodology," *Int. J. of LCA*, vol. 11, pp. 72-80, 2006 2006, doi: 10.1065/lca2006.04.014.
- [149] O. Jolliet et al., "IMPACT 2002+: A new life cycle impact assessment methodology," (in English), *Int. J. of LCA*, vol. 8, pp. 324-330, 2003 2003.
- [150] v. a. PRé, "SimaPro Database Manual - Methods Library," 2016. [Online]. Available: <https://www.pre-sustainability.com/download/DatabaseManualMethods.pdf>
- [151] R. Frischknecht and O. Jolliet, "Global Guidance for Life Cycle Impact Assessment Indicators," Paris, 2016, vol. 1.
- [152] M. Z. Hauschild and M. A. J. Huijbregts, *Life Cycle Impact Assessment*, 1 ed. (LCA Compendium – The Complete World of Life Cycle Assessment). Springer Netherlands, 2015.
- [153] B. W. Vigon et al., "LIFE-CYCLE ASSESSMENT: INVENTORY GUIDELINES AND PRINCIPLES," EPA, Cincinnati, Ohio, US, 1993. [Online]. Available: <https://pdfs.semanticscholar.org/3228/40d20a4b1c5c90009d26375add6c26a045cd.pdf>
- [154] J. W. Owens, "Life-Cycle Assessment: Constraints on Moving from Inventory to Impact Assessment," *Journal of Industrial Ecology*, vol. 1, pp. 37-49, 1997 1997, doi: 10.1162/jiec.1997.1.1.37.
- [155] R. M. Bright, A. H. Strømman, and G. P. Peters, "Radiative Forcing Impacts of Boreal Forest Biofuels: A Scenario Study for Norway in Light of Albedo," *Environ. Sci. Technol.*, vol. 45, no. 17, pp. 7570-7580, 2011/09/01 2011, doi: 10.1021/es201746b.
- [156] W. Klöpffer, "Introducing Life Cycle Assessment and its Presentation in 'LCA Compendium'," in *Background and Future Prospects in Life Cycle Assessment*, W. Klöpffer Ed. Dordrecht: Springer Netherlands, 2014, pp. 1-37.
- [157] R. K. Rosenbaum et al., "USEtox-the UNEP-SETAC toxicity model: recommended characterisation factors for human toxicity and freshwater ecotoxicity in life cycle impact assessment," (in English), *Int. J. of LCA*, vol. 13, pp. 532-546, 2008 Nov 2008, doi: 10.1007/s11367-008-0038-4.
- [158] P. Fantke et al., "Characterizing Aggregated Exposure to Primary Particulate Matter: Recommended Intake Fractions for Indoor and Outdoor Sources," *Environ. Sci. Technol.*, vol. 51, no. 16, pp. 9089-9100, 2017/08/15 2017, doi: 10.1021/acs.est.7b02589.
- [159] P. Fantke et al., "Global Effect Factors for Exposure to Fine Particulate Matter," *Environ. Sci. Technol.*, vol. 53, no. 12, pp. 6855-6868, 2019/06/18 2019, doi: 10.1021/acs.est.9b01800.
- [160] M. Lenzen, C. J. Dey, and S. A. Murray, "Historical accountability and cumulative impacts: the treatment of time in corporate sustainability reporting," *Ecological Economics*, vol. 51, no. 3, pp. 237-250, 2004/12/01/ 2004, doi: <http://dx.doi.org/10.1016/j.ecolecon.2004.06.008>.
- [161] M. Z. Hauschild, "Assessing environmental impacts in a life-cycle perspective," (in English), *Environ. Sci. Technol.*, vol. 39, pp. 81A-88A, 2005 Feb 2005, doi: 10.1021/es053190s.

- [162] A. Kendall, B. Chang, and B. Sharpe, "Accounting for Time-Dependent Effects in Biofuel Life Cycle Greenhouse Gas Emissions Calculations," (in English), *Environ. Sci. Technol.*, vol. 43, no. 18, pp. 7142-7147, 2009 Sep 2009, doi: 10.1021/es900529u.
- [163] S. V. Jørgensen, M. Z. Hauschild, and P. H. Nielsen, "Assessment of urgent impacts of greenhouse gas emissions—the climate tipping potential (CTP)," *Int J Life Cycle Assess*, journal article vol. 19, no. 4, pp. 919-930, April 01 2014, doi: 10.1007/s11367-013-0693-y.
- [164] M. Finkbeiner et al., "Challenges in Life Cycle Assessment: An Overview of Current Gaps and Research Needs," in *Background and Future Prospects in Life Cycle Assessment*, W. Klöpffer Ed., (LCA Compendium – The Complete World of Life Cycle Assessment. Dordrecht: Springer Netherlands, 2014, pp. 207-258.
- [165] P. Fantke, P. Wieland, C. Wannaz, R. Friedrich, and O. Jolliet, "Dynamics of pesticide uptake into plants: From system functioning to parsimonious modeling," *Environmental Modelling & Software*, vol. 40, pp. 316-324, 2013/02/01/ 2013, doi: <https://doi.org/10.1016/j.envsoft.2012.09.016>.
- [166] W. J. Liao, H. M. G. van der Werf, and J. Salmon-Monviola, "Improved Environmental Life Cycle Assessment of Crop Production at the Catchment Scale via a Process-Based Nitrogen Simulation Model," *Environ. Sci. Technol.*, vol. 49, no. 18, pp. 10790-10796, Sep 2015, doi: 10.1021/acs.est.5b01347.
- [167] P. Fantke, R. Juraske, A. Antón, R. Friedrich, and O. Jolliet, "Dynamic Multicrop Model to Characterize Impacts of Pesticides in Food," *Environ. Sci. Technol.*, vol. 45, no. 20, pp. 8842-8849, 2011/10/15 2011, doi: 10.1021/es201989d.
- [168] H. Udo de Haes et al., "Life-cycle impact assessment: striving towards best practice," S. o. E. T. a. C. (SETAC), Ed., 2002 2002.
- [169] A.-M. Boulay et al., "Analysis of water use impact assessment methods (part B): applicability for water footprinting and decision making with a laundry case study," *Int J Life Cycle Assess*, journal article vol. 20, no. 6, pp. 865-879, June 01 2015, doi: 10.1007/s11367-015-0868-9.
- [170] P. Collet, "Analyse de Cycle de Vie de la valorisation énergétique de la biomasse algale : prise en compte des aspects dynamiques dans l'étape d'inventaire," 2012. [Online]. Available: <http://prodirna.inra.fr/?locale=fr#!ConsultNotice:189108>
- [171] M. Núñez, S. Pfister, M. Vargas, and A. Antón, "Spatial and temporal specific characterisation factors for water use impact assessment in Spain," *Int J Life Cycle Assess*, journal article vol. 20, no. 1, pp. 128-138, January 01 2015, doi: 10.1007/s11367-014-0803-5.
- [172] D. García-Gusano, D. Iribarren, and D. Garraín, "Prospective analysis of energy security: A practical life-cycle approach focused on renewable power generation and oriented towards policy-makers," *Applied Energy*, vol. 190, pp. 891-901, 2017/03/15/ 2017, doi: <http://dx.doi.org/10.1016/j.apenergy.2017.01.011>.
- [173] A. Levasseur, O. Bahn, D. Beloin-Saint-Pierre, M. Marinova, and K. Vaillancourt, "Assessing butanol from integrated forest biorefinery: A combined techno-economic and life cycle approach," *Applied Energy*, vol. 198, pp. 440-452, 2017/07/15/ 2017, doi: <http://dx.doi.org/10.1016/j.apenergy.2017.04.040>.
- [174] A. Levasseur, P. Lesage, M. Margni, M. Brandao, and R. Samson, "Assessing temporary carbon sequestration and storage projects through land use, land-use change and forestry: comparison of dynamic life cycle assessment with ton-year approaches," *Climatic Change*, vol. 115, no. 3-4, pp. 759-776, Dec 2012, doi: 10.1007/s10584-012-0473-x.
- [175] C. Woo, Y. Chung, D. Chun, H. Seo, and S. Hong, "The static and dynamic environmental efficiency of renewable energy: A Malmquist index analysis of OECD countries," *Renewable & Sustainable Energy Reviews*, vol. 47, pp. 367-376, Jul 2015, doi: 10.1016/j.rser.2015.03.070.
- [176] P. Collet, L. Lardon, J. P. Steyer, and A. Helias, "How to take time into account in the inventory step: a selective introduction based on sensitivity analysis," *Int. J. of LCA*, vol. 19, no. 2, pp. 320-330, Feb 2014, doi: 10.1007/s11367-013-0636-7.

Appendix B: SOM models

Notes: Main characteristics of soil organic matter models and their applications in life cycle assessment.

Model type	General data requirements	Model	C pools	Residence time (years)	Spatial scale					Temporal scale	Scope	Application in LCA
					P	F	CT	RG	NA			
Empirical models	Climatic Region Soil type Land use (management coefficient/factors) Initial SOC stock (estimated)	(Henin and Dupuis, 1945)			x							Several
		IPCC 1-2 Tier (IPCC, 2006a)										
		AMG (Andriulo et al., 1999)										
Soil process models	Climatic variables (e.g. monthly precipitation, air temperature, PAN evaporation) Soil parameters (e.g. clay, bulk density) Initial SOC stock (estimated)	ROTH-C (Rothamsted carbon model) (Jenkinson and Celeman, 1994)	Decomposable plant material Microbial biomass Resistant plant material Humus Inert organic matter Roots Litter Faeces	0.1 1.5 3.3 50 50 000 0.078 0.078	x	x	x	x	x	Short and long term	Natural vegetation; grazed, arable and forestry ecosystems	Wheat, maize, miscanthus, canola, SRC poplar (residue); dairy and beef cattle, sheep, sugar beet, grassland, land use (Cherubini and Ulgiati, 2010; Hillier et al., 2009; Morais et al., 2018; Styles and Jones, 2007)
		ICBM (Introductory carbon balance model) (Andrén and Kätterer, 1997) has	Young Old	1.25 166				x	x	Medium term (30 years)	Arable ecosystem in cool temperate climate	Several crops (residue, fertiliser, tillage) (Kimming et al., 2011)
	Management variables (e.g. carbon inputs, residue quality, soil cover, manure inputs, type of tillage)	CANDY (Carbon and nitrogen dynamics) (Franko et al., 2002) C-TOOL	Fresh organic matter, Biologically active SOM Slow cycling SOM	2.5 7.14 20	x	x				Short and long term	Arable ecosystem in cool temperate climate	
										Long term		Several crops (willow, miscanthus) (Hamelin et al., 2012; Hillier et al., 2012; Knudsen et al., 2014; Petersen et al., 2013)

Appendices

	APSIM (Agricultural production systems simulator)	Fresh OM Microbial biomass Humus	0.01–0.29 0.34 18.26	x x					Short term	Arable ecosystems, forest ecosystems	
--	--	--	----------------------------	--------	--	--	--	--	------------	---	--

Acronyms: P: Plot, F: Field, CT: Catchment; RG: Regional; NT: National; GL: Global; OM: Organic matter; SOM: Soil organic matter; MB: Source: based on (FAO, 2018b; Goglio et al., 2015; Shibu et al., 2006; Stockmann et al., 2013)

Appendix C: Biomass pathways

Detailed overview of potential biogenic carbon process pathways along the life cycle phases (own elaboration).

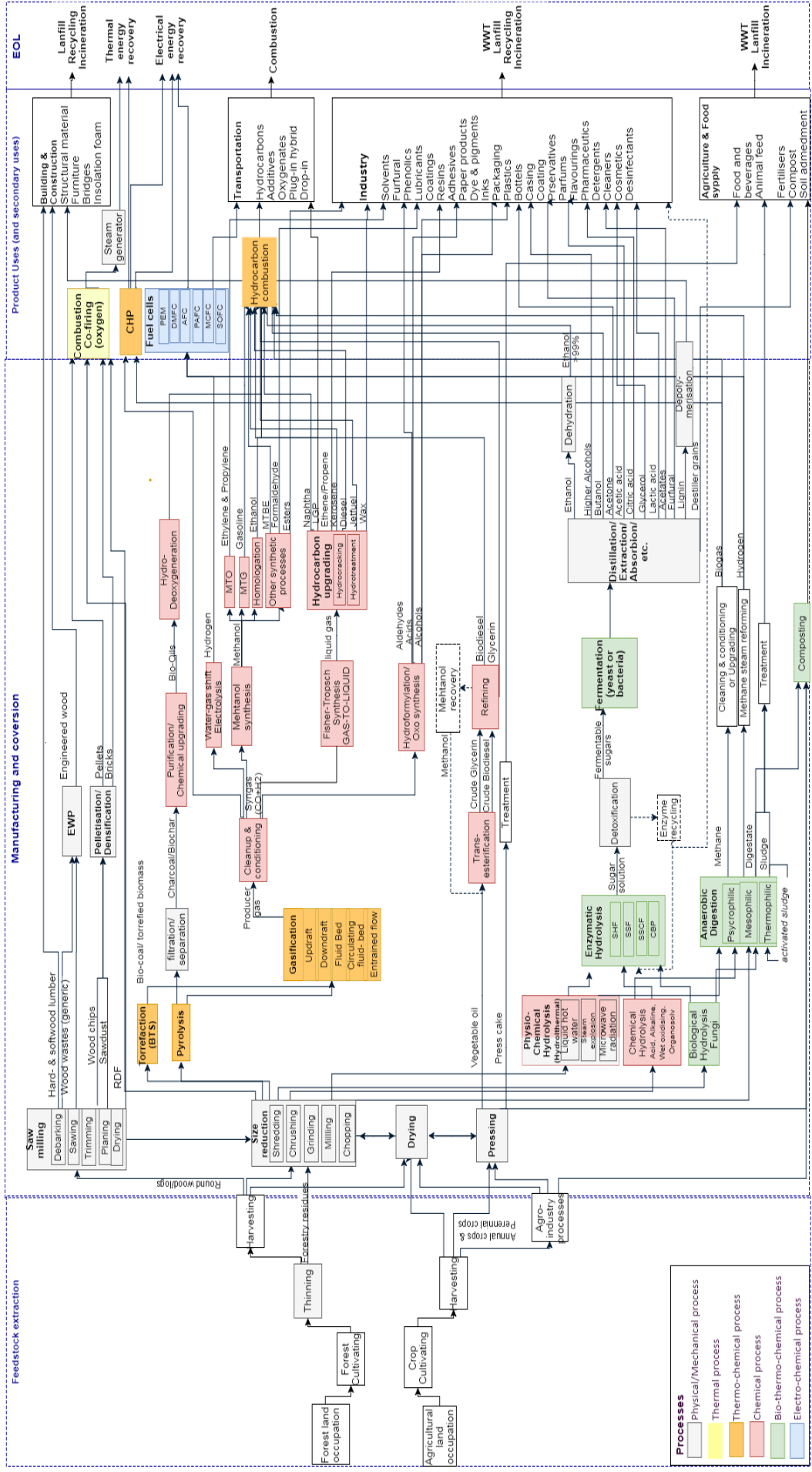

Appendix D: Data paper on forest models

This Appendix contains a Data Article, informing on forest tree growth and forest stand management practices for modelling C_{bio} fixation/sequestration flows of forest-based products, published in the Journal Data in Brief, open access article (<https://doi.org/10.1016/j.dib.2019.103841>) [received 3 April 2018, received in revised form 6 April 2018, accepted 25 April 2018, available online 9 May 2018].

Objective	Compilation of data supporting and informing dynamic modelling to predict biomass growth and carbon fixation dynamics, of a tree or forest stand, over specific rotation lengths.
Approach	Non-linear growth model and allometric relations
Sector (product)	N/A
Biomass	Forest wood
Referred to	Supplementary Material online available (https://doi.org/10.1016/j.dib.2019.103841) Paper 1 (section 4.2) and Paper 2 (section 4.3)

Data and non-linear models for the estimation of biomass growth and carbon fixation in managed forests

Ariane Albers^{a,b,c,*}, **Pierre Collet**^a, **Anthony Benoist**^{c,d}, **Arnaud Hélias**^{b,c,e}

^a IFP Energies Nouvelles, 1 et 4 Avenue de Bois-Préau, 92852 Rueil-Malmaison, France

^b LBE, Montpellier SupAgro, INRA, UNIV Montpellier, Narbonne, France

^c Elsa, Research Group for Environmental Lifecycle and Sustainability Assessment, Montpellier, France

^d CIRAD – UPR BioWooEB, Avenue Agropolis, F-34398 Montpellier, France

^e Chair of Sustainable Engineering, Technische Universität Berlin, Berlin, Germany

* Corresponding author

Abstract

The data and analyses presented support the research article entitled “Coupling partial-equilibrium and dynamic biogenic carbon models to assess future transport scenarios in France” [1]. Carbon sequestration and storage in forestry products (e.g. transport fuels) is sought as a climate change mitigation option. The data presented support and inform dynamic modelling approaches to predict biomass growth and carbon fixation dynamics, of a tree or forest stand, over specific rotation lengths. Data consists of species-specific yield tables, parameters for non-linear growth models and allometric equations. Non-linear growth models and allometric equations are listed and described. National statistics and surveys of the wood supply chain serve to identify main tree species, standing wood volumes and distributions within specific geographies; here corresponding to managed forests in France. All necessary data and methods for the computation of the annual fixation flows are presented.

Keywords: biogenic carbon modelling; carbon fixation; forestry biomass; non-linear growth

Specification table

Subject area	Biology, Ecological modelling
More specific subject area	Dynamic modelling of forest biomass growth and annual carbon fixation
Type of data	Text, figures, tables
How data was acquired	Combination of secondary sources from public datasets available online and peer-reviewed literature, including national statistics and surveys, yield tables, non-linear growth parameters and allometric relations.
Data format	Filtered and analysed secondary data.
Experimental factors	Some data was re-expressed into different units when necessary to inform the models.
Experimental features	Non-linear growth was computed using data retrieved from yield tables. Initial parameters were compiled from literature to fit the non-self-starting non-linear regression model used for growth. Allometric equations were compiled and selected for tree volume estimations. Finally, mean biomass growth and carbon fixation was computed per one tonne of forestry biomass of interest.
Data source location	Managed forest systems in France or from other regions when data was not available for France (see Table 1).
Data accessibility	All data used and generated is included in this article and in its Supplementary Material
Related research article	A. Albers, P. Collet, D. Lorne, A. Benoist, A. Hélias, Coupling partial-equilibrium and dynamic biogenic carbon models to assess future transport scenarios in France, <i>Appl. Energy</i> . 239 (2019) 316–330. doi:10.1016/j.apenergy.2019.01.186

Value of the Data

- A large compilation of secondary data, useful to facilitate dynamic carbon modelling of biomass growth and carbon fixation in managed forest systems.
- Part of the data is generic enough to be used to model stands of unknown or mixed species.
- The proposed modelling approach is flexible and applicable to any tree species and management practice (R script to fit non-self-starting non-linear regression growth parameters included).
- Annual carbon stocking factors are provided for all tree species of the French wood supply chain.

1 Data

The data presented provides the basis for a non-linear forestry biomass growth model, whose outputs were used for modelling time-dependent carbon fixation in forest biomass [1]. This data article aggregates data from various datasets, including national statistics and surveys, yield tables, non-linear growth parameters and allometric relations (Table 1). The wood supply chain in France is represented by 12 main forest tree species (Table 2). National surveys and statistical results describe the distribution per tree species, used for weighted mean estimates (Table 3). Yield tables tabulate the age-dependent mean tree development and productivity of fully stocked managed stands, measured largely from long-standing experimental forest stand surveys. Yield table data is used to estimate i) initial parameters to fit non-self-starting non-linear regression models to predict tree growth, ii) age-dependent growth variables, and iii) site-dependent management practices (e.g. thinning periods, rotation cycles). Allometric models are used for volume estimation. All data sources primary originate from French studies, for geographical coherence. However, adequate European studies were retained when French data was unavailable (Table 4). Biomass yield and carbon content were obtained by applying specific conversions factors (Table 5). The Supplementary Material provides technical guidance and data for all assessed tree species concerning selected yield tables, regression analysis and parameters, biomass yield calculations, and annual carbon stocking factors. It includes a R [2] script to compute the regression parameters for running the growth model, applicable to future studies.

Table 1. General sources

Specific data	Databases	Source
Species traits	Global TRY Plant Trait Database (https://www.try-db.org/TryWeb/Home.php)	[3]
National forestry inventories	National Institute of Geographic and Forest Information, Ministry of Agriculture, Agro-food and Forests	[4]
Wood density	International DRYAD Global Wood Density Database (http://datadryad.org/)	[5]
Allometric equations	GlobAllomeTree international database platform (http://www.globalloometree.org/about/)	[6]
Carbon content	Food and Agricultural institute (FAO), Forestry Commission, and other	[7,8]

Table 2. Species traits of forest species wood supply chain in France

Common name	Species botanical name	Family	Genus	Species epithet	Leaf type	Leaf Phenology
Douglas fir	<i>Pseudotsuga menziesii</i>	Pinaceae	<i>Pseudotsuga</i>	<i>menziesii</i>	needle	evergreen
Norway spruce	<i>Picea abies</i>	Pinaceae	<i>Picea</i>	<i>abies</i>	needle	evergreen
Maritime pine	<i>Pinus pinaster</i>	Pinaceae	<i>Pinus</i>	<i>pinaster</i>	needle	evergreen
Silver fir	<i>Abies alba</i>	Pinaceae	<i>Abies</i>	<i>Alba</i>	needle	evergreen
Scots pine	<i>Pinus sylvestri</i>	Pinaceae	<i>Pinus</i>	<i>sylvestri</i>	needle	evergreen
Sweet chestnut	<i>Castanea sativa</i>	Fagaceae	<i>Castanea</i>	<i>sativa</i>	broadleaf	deciduous
Hornbeam	<i>Carpinus betulus</i>	Corylaceae	<i>Carpinus</i>	<i>betulus</i>	broadleaf	deciduous
Ash	<i>Fraxinus excelsior</i>	Oleaceae	<i>Fraxinus</i>	<i>excelsior</i>	broadleaf	deciduous
European beech	<i>Fagus sylvatica</i>	Fagaceae	<i>Fagus</i>	<i>sylvatica</i>	broadleaf	deciduous
Sessile oak	<i>Quercus petraea</i>	Fagaceae	<i>Quercus</i>	<i>petraea</i>	broadleaf	deciduous
English oak	<i>Quercus robur</i>	Fagaceae	<i>Quercus</i>	<i>robur</i>	broadleaf	deciduous
White oak	<i>Quercus pubescens</i>	Fagaceae	<i>Quercus</i>	<i>pubescens</i>	broadleaf	deciduous

Source: Global TRY Plant Trait Database [3]

Table 3. National inventory (2012-2016) and distribution of living standing volume per forest tree species in France

Common name	Species	Distribution standing volume [Bm ³]	Distribution standing volume [%]
Douglas fir	<i>P. menziesii</i>	106	4
Norway spruce	<i>P. abies</i>	213	8
Maritime pine	<i>P. pinaster</i>	133	5
Silver fir	<i>A. alba</i>	213	8
Scots pine	<i>P. sylvestri</i>	160	6
Other conifers	Pinaceae spp	146	6
Sweet chestnut	<i>C. sativa</i>	135	5
Hornbeam	<i>C. betulus</i>	108	4
Ash	<i>F. excelsior</i>	108	4
European beech	<i>F. sylvatica</i>	297	11
Sessile oak	<i>Q. petraea</i>	297	11
English oak	<i>Q. robur</i>	297	11
White oak	<i>Q. pubescens</i>	108	4
Other broadleaved	Fagaceae spp	365	14

Source: [4]

Appendices

Table 4. Specifications on analysed yield tables per forest tree species

Common name	Species	Country	Eco-region	Geographical specifications	Yield class	Source	Page in source document
Douglas fir	<i>P. menziesii</i>	France	West Massif Central	Creuse, Corrèze et Haute-Vienne	2	[9]	50
Norway spruce	<i>P. abies</i>	France	South Massif Central	Montagne Noire, Monts de Lacune-Sommail-Espinouse, Levezou and Aigoual	16	[9]	134
Maritime pine	<i>P. pinaster</i>	France	South-West	Landes de Gascogne	3	[9]	54
Silver fir	<i>A. alba</i>	France	Jura	N/A	12	[9]	112
Scots pine	<i>P. sylvestri</i>	France	Sologne	N/A	3	[9]	20
Other conifers	<i>C. sativa</i>	Spain	North Spain	N/A	4	[10]	131
Sweet chestnut	<i>C. betulus</i>	N/A	European part	Eco-regions of deciduous forests and forest steppe	2	[11]	375
Hornbeam	<i>F. excelsior</i>	N/A	Northern Eurasia	N/A	2	[11]	108
Ash	<i>F. sylvatica</i>	France	North-West	N/A	6	[9]	84
European beech	<i>Q. petraea</i>	France	Loire	N/A			
Sessile oak	<i>Q. robur</i>	N/A	European part	Eco-regions of mixed forests, deciduous forests and forest steppe	1a	[9]	294
English oak	<i>Q. pubescens</i>	N/A	European part	Eco-regions of mixed forests, deciduous forests and forest steppe	2	[11]	295

Table 5. Wood density and carbon content per forest tree species

Common name	Species	Wood density [$t \cdot m^{-3}$]	Carbon content [$C \cdot t^{-1}$]
Douglas fir	<i>P. menziesii</i>	0.4533	0.5280
Norway spruce	<i>P. abies</i>	0.3700	0.4980
Maritime pine	<i>P. pinaster</i>	0.4140	0.5212
Silver fir	<i>A. alba</i>	0.3530	0.4750
Scots pine	<i>P. sylvestri</i>	0.4219	0.5036
Other conifers	Pinaceae spp	0.4024	0.5052
Sweet chestnut	<i>C. sativa</i>	0.4400	0.5010
Hornbeam	<i>C. betulus</i>	0.7060	0.4899
Ash	<i>F. excelsior</i>	0.5597	0.4918
European beech	<i>F. sylvatica</i>	0.5855	0.4709
Sessile oak	<i>Q. petraea</i>	0.5597	0.4970
English oak	<i>Q. robur</i>	0.5597	0.5016
White oak	<i>Q. pubescens</i>	0.5597	0.4948
Other broadleaved	Fagacea spp	0.5672	0.4924

Note: General recommended factors are 0.5 $t \cdot m^{-3}$ for conifers/evergreen and 0.6-0.7 $t \cdot m^{-3}$ for broadleaves/deciduous. The carbon content for all tree organs (different tree compartments), can be estimated with a factor of 0.5, by neglecting the lower carbon concentration in the needles/leaves [12].

2 Experimental Design, Materials, and Methods

The presented data is used to inform the models described in the following sub-sections.

2.1 Modelling non-linear growth

The cumulative tree growth is represented by the non-linear Chapman-Richards (CR) curve. The CR equation (Eq. 1) is based on species- and site-dependent parameters and one independent variable, with the following notation [13]:

$$\omega(t_i) = A(1 - \beta \exp^{-kt})^p + \varepsilon \quad (1)$$

$$\text{with } p = 1/(1 - m)$$

where ω expresses the potential growth of a tree species i in height and circumference (response growth variables) at age t (independent variable), A, β, k, p are parameters, \exp is the basis of natural logarithm and ε the term for random error; with β is fixed to 1 [14], and the allometric constant m fixed to 0.5 ($0 < m < 1$) [13]. CR forms a sigmoid and asymptotic curve with a point of inflection determined by the allometric constant p , approaching a maximum threshold of the response variable, the asymptote A . The empirical growth parameter k scales the absolute growth, governing the rate at which A approaches its potential maximum.

2.2 Initial parameters to fit non-self-starting non-linear regression model

The statistical model using the CR curve [$\omega \sim f(t_i, \theta) + \varepsilon$] fits the vector of parameters θ to the growth variable ω ; whereby the function f represents a non-linear combination of the parameters. Initial parameters to fit the non-self-starting non-linear regression model (Table 6) were developed for k and p . Values for k lie between 0.02 and 0.04, depending on the studied species and for p 2. The acceptable values for k range between 0.2 and 2.5. A is estimated as twice the maximum value given for age in the species-specific yield tables.

Appendices

Table 6. Initial parameter for Chapman-Richards non-linear regression

Common name	Species	Initial parameters		
		A	k	p
Douglas fir	<i>P. menziesii</i>	140	0.03	2
Norway spruce	<i>P. abies</i>	172	0.03	2
Maritime pine	<i>P. pinaster</i>	140	0.03	2
Silver fir	<i>A. alba</i>	326	0.03	2
Scots pine	<i>P. sylvestri</i>	180	0.03	2
Other conifers	Pinaceae spp	172	0.03	2
(Sweet) Chestnut	<i>C. sativa</i>	120	0.03	2
Hornbeam	<i>C. betulus</i>	200	0.02	2
Ash	<i>F. excelsior</i>	320	0.03	2
European Beech	<i>F. sylvatica</i>	300	0.02	2
White oak	<i>Q. petraea</i>	240	0.04	2
English oak	<i>Q. robur</i>	320	0.02	2
Sessile oak	<i>Q. pubescens</i>	400	0.04	2
Other broadleaves	Fagacea spp	300	0.04	2

Sources: A. Pommerening, pers. comm.; H. Pretzsch, pers. comm

2.3. Allometric equations and specifications

Allometric models presented in Table 7 are used for tree volume estimation.

Table 7. Overview of retained allometric equations for volume estimations

Species	Allometric equation	Coefficients	Volume	Location	Creator	Source
		α β γ δ ε				
<i>P. menziesii</i>	$V_{T\ above} = (a + \beta \times Ci) \times (1 + \delta / (Ci^2)) \times Ci^2 \times H / (4 \times 10^4 \times \pi)$	5.3E-1 -5.3E-4 -	Total AG	FRA	INRA	[15]
<i>P. abies</i>	$V_{T\ above} = (a + \beta \times Ci) \times Ci^2 \times H / (4 \times 10^4 \times \pi)$	6.3E-1 -9.5E-4 -	Total AG	FRA	INRA	[15]
<i>P. pinaster</i>	$V_{T\ above} = (a + \beta \times Ci) + \gamma \times Ci^{1/2/H} \times (1 + (\delta / Ci^2)) \times Ci^2 \times H / (4E + 04^4 \times \pi)$	2.4E-1 9.7E-4 4.0E-1	Total AG	FRA	INRA	[15]
<i>A. alba</i>	$V_{stem} = (a + \beta \times (Ci/\pi)^2) \times H + \gamma \times (Ci/\pi)^2$	-2.8E+0 3.4E-2 8.4E-2	Stem UB	ITA	CMCC	[16]
<i>P. sylvestris</i>	$V_{T\ above} = (a + \beta \times Ci) + \gamma \times Ci^{1/2/H} \times (1 + (\delta / Ci^2)) \times Ci^2 \times H / (4 \times 10^4 \times \pi)$	3.0E-1 3.2E-4 3.8E-1	Total AG	FRA	INRA	[15]
Pinaceae spp	$V_{T\ above} = (a + \beta \times Ci) + \gamma \times Ci^{1/2/H} \times (1 + (\delta / Ci^2)) \times Ci^2 \times H / (4 \times 10^4 \times \pi)$	3.0E-1 3.2E-4 3.8E-1	Total AG	FRA	INRA	[15]
<i>C. sativa</i>	$V_{stem} = \alpha \times (Ci/\pi)^2 \times H + \beta$	3.8E-2 8.5E-1 -	Stem UB	FRA	FCBA	[17]
<i>C. betulus</i>	$V_{stem} = \alpha \times (Ci/\pi)^2 \times H + \beta$	3.3E-2 3.0E+0 -	Stem UB	FRA	FCBA	[17]
<i>F. excelsior</i>	$V_{stem} = (Ci/\pi)^\alpha \times H^\beta \times e^{-\gamma}$	2.0E+0 7.7E-1 2.5E+0	Stem UB	NDL	CMCC	[18]
<i>F. sylvatica</i>	$V_{T\ above} = (a + \beta \times Ci) + \gamma \times Ci^{1/2/H} \times (1 + (\delta / Ci^2)) \times Ci^2 \times H / (4 \times 10^4 \times \pi)$	4.0E-1 2.7E-4 4.2E-1	Total AG	FRA	INRA	[15]
<i>Q. petraea</i>	$V_{T\ above} = (a + \beta \times Ci) + \gamma \times Ci^{1/2/H} \times (1 + (\delta / Ci^2)) \times Ci^2 \times H / (4 \times 10^4 \times \pi)$	4.7E-1 -3.5E-4 3.8E-1	Total AG	FRA	INRA	[15]
<i>Q. robur</i>	$V_{stem} = (Ci/\pi)^\alpha \times H^\beta \times e^{-\gamma}$	2.0E+0 8.6E-1 2.9E+0	Stem UB	NDL	CMCC	[18]
<i>Q. pubescens</i>	$V_{stem} = \alpha \times 10^{(\beta \times \text{LOG}(Ci/\pi))} + \gamma \times \text{LOG}(Ci/\pi)^2 \times + \delta \times \text{LOG}(H) + \varepsilon \times \text{LOG}(H)^2$	3.5E-4 1.1E+0 3.1E-1	Stem UB	ROU	CMCC	[19]
<i>Fagaceae spp</i>	$V_{T\ above} = (a + \beta \times Ci) + \gamma \times Ci^{1/2/H} \times (1 + (\delta / Ci^2)) \times Ci^2 \times H / (4 \times 10^4 \times \pi)$	4.7E-1 3.5E-4 3.8E-1	Total AG	FRA	INRA	[15]

Acronyms: H: top height; DBH: Diameter breast height; Ci: Circumference; Total AG: total aboveground; Stem UB: stem under bark; FRA: France; ITA: Italy; NDL: Netherlands; ROU: Romania

Note: Equations are all expressed in Ci and the given units needed respective conversions to be expressed in common units. The volume is expressed in stem under bark (i.e. bark and wood) or total aboveground tree volume. The total aboveground volume includes stem under bark, needles/leaves and branches. The group “other conifers” (*Pinaceae spp*) and “other broadleaved” (*Fagaceae spp*) use the same volume relations as Scots pine and Sessile oak respectively, due to their representativeness.

Source: Allometric equations analysed and selected from [6]; and respective references in the table

2.4. Mean biomass growth development of all species

Figure 1 shows the non-linear mean biomass growth per tree species. For the computation of annual C_{bio} fixation flows [$t C_{bio} \cdot yr^{-1}$] in biomass (as presented with the stocking factors in the Supplementary material) see section 2.3.1 in the companion research article [1]. Data from Table 3 to Table 7 are used for these calculations.

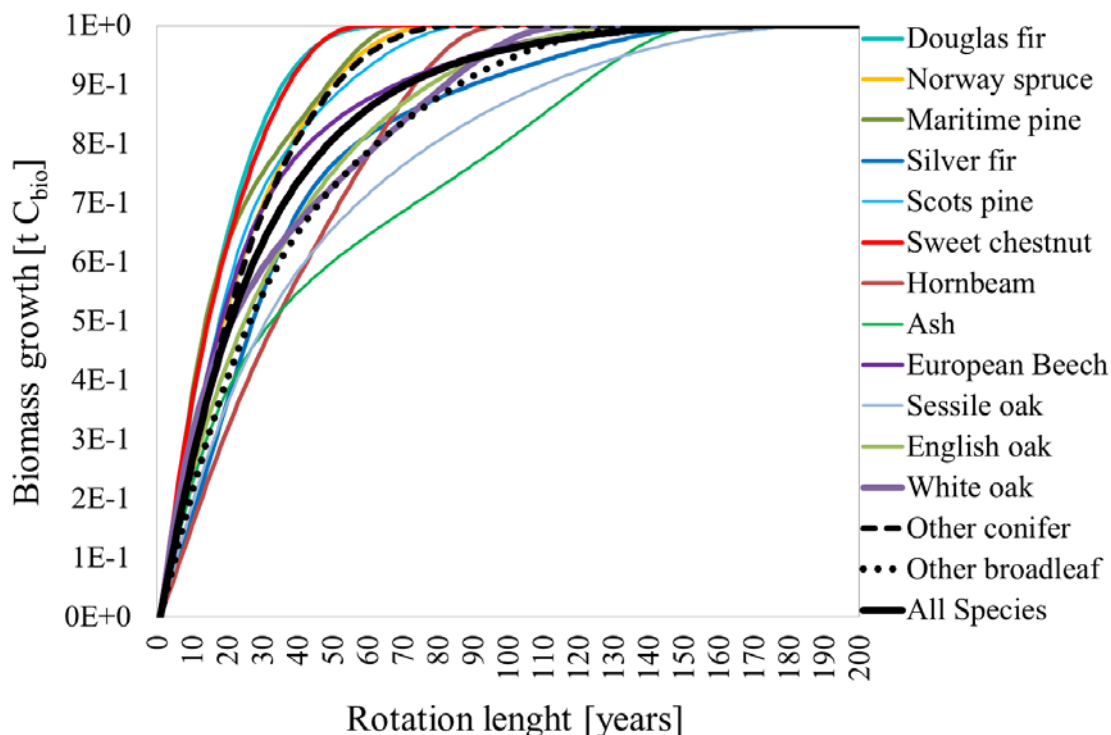

Fig. 1: Mean biomass growth in tonnes of carbon per tree species

Acknowledgments

The authors would like to acknowledge the valuable inputs from Prof. Hans Pretzsch (TU Munich) and Prof. Arne Pommerening (Swedish University of Agricultural Sciences). This work is part of a Ph.D. research work of Ariane Albers supported by IFP Energies nouvelles doctoral grant.

References for Appendix D

- [1] A. Albers, P. Collet, D. Lorne, A. Benoist, A. Hélias, Coupling partial-equilibrium and dynamic biogenic carbon models to assess future transport scenarios in France, *Appl. Energy*. 239 (2019) 316–330. doi:10.1016/j.apenergy.2019.01.186.
- [2] R Core Team, R: A language and environment for statistical computing., R Found. Stat. Comput. (2018). <http://www.r-project.org/>.
- [3] J. Kattge, S. Díaz, S. Lavorel, I.C. Prentice, P. Leadley, G. Bönisch, E. Garnier, M. Westoby, P.B. Reich, I.J. Wright, J.H.C. Cornelissen, C. Violle, S.P. Harrison, P.M. Van Bodegom, M. Reichstein, B.J. Enquist, N.A. Soudzilovskaia, D.D. Ackerly, M. Anand, O. Atkin, M. Bahn, T.R. Baker, D. Baldocchi, R. Bekker, C.C. Blanco, B. Blonder, W.J. Bond, R. Bradstock, D.E. Bunker, F. Casanoves, J. Cavender-Bares, J.Q. Chambers, F.S. Chapin, J. Chave, D. Coomes, W.K. Cornwell, J.M. Craine, B.H. Dobrin, L. Duarte, W. Durka, J. Elser, G.

- Esser, M. Estiarte, W.F. Fagan, J. Fang, F. Fernández-Méndez, A. Fidelis, B. Finegan, O. Flores, H. Ford, D. Frank, G.T. Freschet, N.M. Fyllas, R. V. Gallagher, W.A. Green, A.G. Gutierrez, T. Hickler, S.I. Higgins, J.G. Hodgson, A. Jalili, S. Jansen, C.A. Joly, A.J. Kerkhoff, D. Kirkup, K. Kitajima, M. Kleyer, S. Klotz, J.M.H. Knops, K. Kramer, I. Kühn, H. Kurokawa, D. Laughlin, T.D. Lee, M. Leishman, F. Lens, T. Lenz, S.L. Lewis, J. Lloyd, J. Llusià, F. Louault, S. Ma, M.D. Mahecha, P. Manning, T. Massad, B.E. Medlyn, J. Messier, A.T. Moles, S.C. Müller, K. Nadrowski, S. Naeem, Ü. Niinemets, S. Nöllert, A. Nüske, R. Ogaya, J. Oleksyn, V.G. Onipchenko, Y. Onoda, J. Ordoñez, G. Overbeck, W.A. Ozinga, S. Patiño, S. Paula, J.G. Pausas, J. Peñuelas, O.L. Phillips, V. Pillar, H. Poorter, L. Poorter, P. Poschlod, A. Prinzing, R. Proulx, A. Rammig, S. Reinsch, B. Reu, L. Sack, B. Salgado-Negret, J. Sardans, S. Shiodera, B. Shipley, A. Siefert, E. Sosinski, J.F. Soussana, E. Swaine, N. Swenson, K. Thompson, P. Thornton, M. Waldram, E. Weiher, M. White, S. White, S.J. Wright, B. Yguel, S. Zaehle, A.E. Zanne, C. Wirth, TRY - a global database of plant traits, *Glob. Chang. Biol.* 17 (2011) 2905–2935. doi:10.1111/j.1365-2486.2011.02451.x.
- [4] IGN, Le mémento inventaire forestier édition 2017, IGN-Institut Natl. l'information Géographique For. 2017 (2017) 30. https://inventaire-forestier.ign.fr/IMG/pdf/memento_2017.pdf (accessed July 20, 2018).
- [5] A. Zanne, G. Lopez-Gonzalez, D. Coomes, J. Ilic, S. Jansen, S. Lewis, R. Miller, N. Swenson, M. Wiemann, J. Chave, Global Wood Density Database, *Dryad Digit. Repos.* (2009). <http://datadryad.org/resource/doi:10.5061/dryad.234/1> (accessed September 6, 2017).
- [6] M. Henry, A. Bombelli, C. Trotta, A. Alessandrini, L. Birigazzi, G. Sola, G. Vieilledent, P. Santenoise, F. Longuetaud, R. Valentini, N. Picard, L. Saint-André, GlobAllomeTree: International platform for tree allometric equations to support volume, biomass and carbon assessment, *IForest.* 6 (2013) 326–330. doi:10.3832/ifor0901-006.
- [7] E.S. Domalski, T.L. Jobe Jr, T.A. Milne, Thermodynamic Data for Biomass Conversion and Waste Incineration, Report SP-271-2839. Lakewood: NREL-Solar Energy Research Institute, 1986. <https://www.nrel.gov/docs/legosti/old/2839.pdf>.
- [8] G. Matthews, The Carbon Content of Trees: Technical paper 4, Crown, Edinburgh, 1993. doi:ISBN 0 85538 317 8.
- [9] INRA/ONF/ENGREF, Tables de production pour les forêts françaises, 2e édition, INRA-Centre National de Recherche Forestières, ONF- Office National des Forêts, ENGREF- Ecole Nationale du Génie rural, des Eaux et des Forêts, Nancy, 1984.
- [10] M. Menéndez-Miguélez, P. Álvarez-álvarez, J. Majada, E. Canga, Management tools for *Castanea sativa* coppice stands in northwestern Spain [Spanish: Herramientas de gestión para masas de monte bajo de *Castanea sativa* en el noroeste de España], *Bosque.* 37 (2016) 119–133. doi:10.4067/S0717-92002016000100012.
- [11] A. Shvidenko, D. Schepaschenko, S. Nilsson, Y. Boului, Federal Agency of Forest Management International Institute for Applied Systems Analysis Tables and Models of Growth and Productivity of Forests of Major Forest Forming Species of Northern Eurasia (standard and reference materials), Moscow, 2008. http://webarchive.iiasa.ac.at/Research/FOR/forest_cdrom/Articles/THR.pdf.
- [12] H. Pretzsch, Forest Dynamics, Growth and Yield- From Measurement to Model, Springer-Verlag, Berlin Heidelberg, 2009. doi:10.1007/978-3-540-88307-4.
- [13] D. Fekedulegn, M.P. Mac Siurtain, J.J. Colbert, Parameter estimation of nonlinear growth models in forestry, *Silva Fenn.* 33 (1999) 327–336. doi:10.14214/sf.653.
- [14] A. Pommerening, A. Muszta, Relative plant growth revisited: Towards a mathematical standardisation of separate approaches, *Ecol. Modell.* 320 (2016) 383–392. doi:10.1016/j.ecolmodel.2015.10.015.

Appendices

- [15] P. Vallet, J.F. Dhôte, G. Le Moguédec, M. Ravart, G. Pignard, Development of total aboveground volume equations for seven important forest tree species in France, *For. Ecol. Manage.* 229 (2006) 98–110. doi:10.1016/j.foreco.2006.03.013.
- [16] P. Gasparini, M. Nocetti, G. Tabacchi, V. Tosi, Biomass equations and data for forest stands and shrublands of the Eastern Alps (Trentino, Italy), in: *IUFRO Conf. (Sustainable For. Theory Pract. 5-8 April 2005, Sustainable Forestry in Theory and Practice USDA General Technical Report PNW-GTR-688*, Edinburgh, 2006. http://www.fs.fed.us/pnw/pubs/pnw_gtr688/papers/Stats & Mod/session1/Gasparini.pdf.
- [17] G. Hollinger, Synthèse des expérimentations réalisées sur les différents chantiers. *Annales de mécanisation forestière*, Paris, 1987.
- [18] E.J. Dik, Estimating the wood volume of standing trees in forestry practice., *Uitvoerige verslagen*, Wageningen, 1984.
- [19] V. Giurgiu, O expresie matematica unica a relatiei diametru - inaltime - volum, pentru majoritatea speciilor forestiere din Romania, 1974.

Appendix E: SM of Paper 2

This appendix contains the **Supplementary Material of Paper 2** (section 4.3): Back to the future: Dynamic full carbon accounting applied to prospective bioenergy scenarios

1 Static versus dynamic LCA approaches

Comparison between classical and dynamic LCA approaches concerning the time dimension, biogenic carbon and climate change.

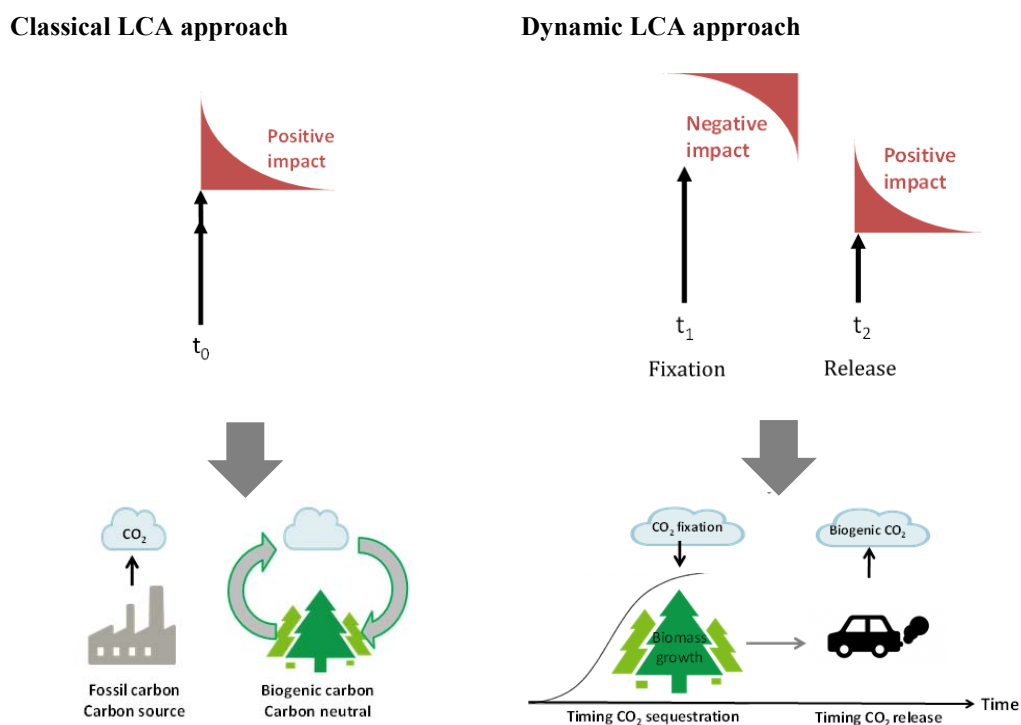

Approach	Aggregation of all carbon flows	Temporal differentiation of carbon flows
LCI	Carbon neutral (sequestration and release sum up to zero)	Biogenic carbon accounting (timing all sequestration and release flows)
LCIA	Static, with fixed time horizon (GWP 20 or 100 years)	Time-dependent, with flexible/variable time horizon

2 Partial-equilibrium model (TIMES-MIRET) outputs

2.1 Biomass commodity outputs

Fig 1. shows all biomass commodity outputs of TIMES-MIRET partial-equilibrium model of the LTECV scenario simulation. This study was concerned with modelling the dynamic biogenic carbon flows of the commodity **forest wood residue**. The annual mean FoWooR supply, described in the LTECV scenario, is estimated at 34 Mt from 2019 to 2050. The mean share to the final energy consumption (energy and transport fuels) amounted to 65%, with higher shares up to 76% during the first decade and subsequent drops to 54% in the year 2050. The decreasing FoWooR share was traced back to the increasing biomass shares from other

2G feedstocks, involving agro-industrial residues and dedicated lignocellulosic material in response to the new set of policy targets. A significant portion of the FoWooR share is mobilised to the transport sub-sector, amounting between 40-50% from the year 2030 to 2050). The FoWooR commodity was linked to Fisher-Tropsch processes for transport fuels (biodiesel and biojet fuels), as well as methanisation and cogeneration for the energy mix.

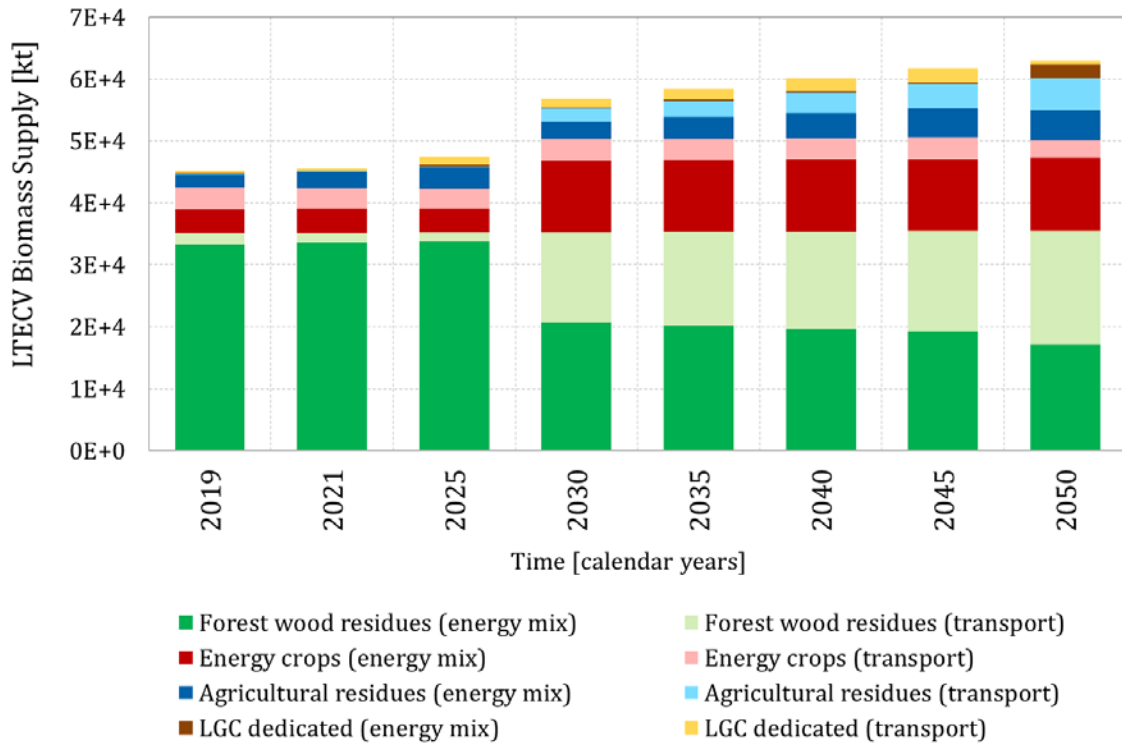

Fig. 1. Biomass supply outputs [per kt] from the partial-equilibrium model in response LTECV scenario

2.2 Greenhouse gas emissions outputs from the partial-equilibrium model

Fig. 2 shows the greenhouse gas emission outputs of the entire energy-transport sector of France (electricity, heat and transport fuels), based on the fossil-sourced CO₂ and N₂O elementary flows, assessed in the partial-equilibrium model with the LTECV scenario simulation. Biogenic flows are excluded in this representation, as it represents a static assessment, providing carbon neutral results, without timing the emissions, based on the static IPCC GWP metric 100 years.

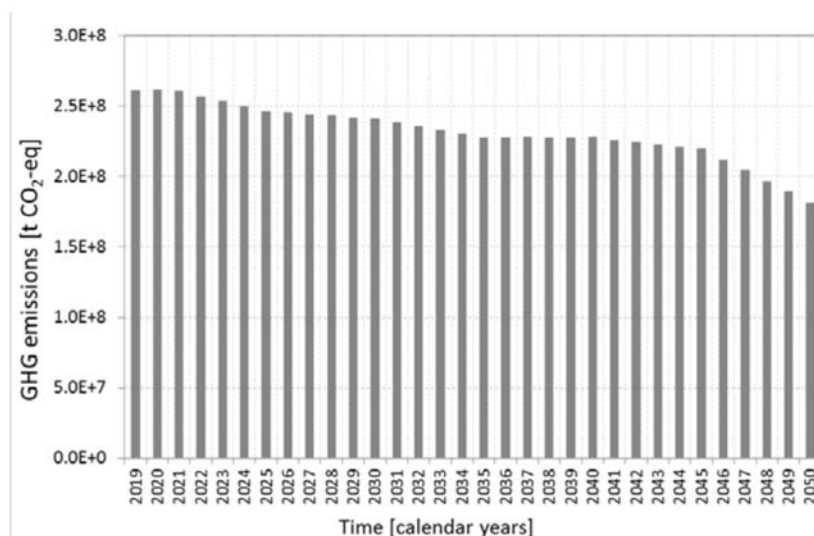

Fig. 2. Greenhouse gas emissions (excluding biogenic flows) of the partial-equilibrium model in response LTECV scenario

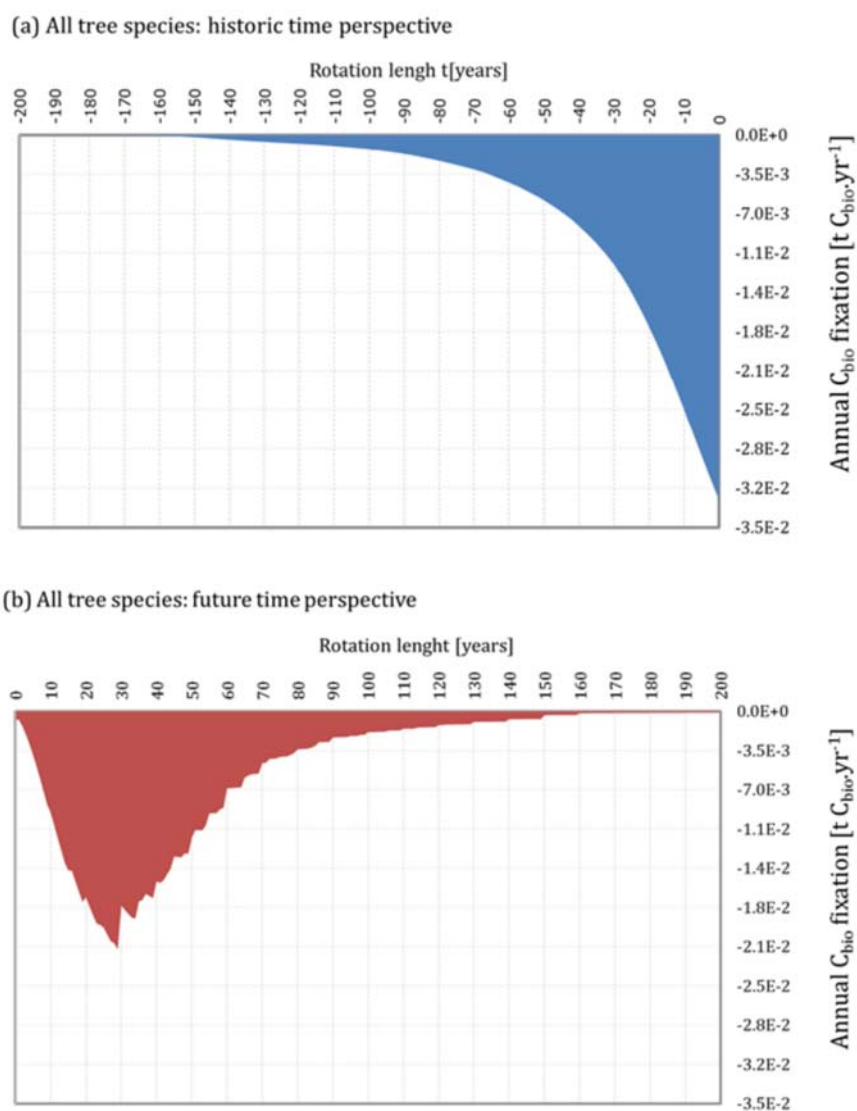

Fig.3. Means annual biogenic carbon stocking factors of biogenic carbon (C_{bio}) fixation of the French wood supply main species [$t \cdot C_{bio} \cdot yr^{-1}$]

3 Outputs from forest carbon modelling

Fig. 3 shows the dynamic outputs from biogenic carbon sequestration modelling for a) historic and b) future time perspectives.

Table 1 and Table 2 show the dynamic stocking/fixation factors for biogenic carbon sequestration of forestry wood residues per modelling approach (historic or future); as means value from all tree species of the French wood supply chain. Values are retrieved from the study (Albers et al. 2019).

Table 1. Historic biogenic carbon (C_{bio}) fixation factors in $t C_{bio} yr^{-1}$ over a maximum rotation length of 200 years

yr	$t C_{bio} \cdot yr^{-1}$	yr	$t C_{bio} \cdot yr^{-1}$	yr	$t C_{bio} \cdot yr^{-1}$	yr	$t C_{bio} \cdot yr^{-1}$	yr	$t C_{bio} \cdot yr^{-1}$
-200	0.0000E+0	-155	-1.1959E-4	-110	-1.0002E-3	-65	-3.5930E-3	-20	-1.7049E-2
-199	-4.1275E-8	-154	-1.3411E-4	-109	-1.0256E-3	-64	-3.7246E-3	-19	-1.7752E-2
-198	-2.3716E-7	-153	-1.4987E-4	-108	-1.0513E-3	-63	-3.8478E-3	-18	-1.8396E-2
-197	-5.8325E-7	-152	-1.6662E-4	-107	-1.0774E-3	-62	-3.9743E-3	-17	-1.9097E-2
-196	-1.0666E-6	-151	-1.8413E-4	-106	-1.1036E-3	-61	-4.1015E-3	-16	-1.9810E-2
-195	-1.6776E-6	-150	-2.0225E-4	-105	-1.1300E-3	-60	-4.2270E-3	-15	-2.0575E-2
-194	-2.4075E-6	-149	-2.2239E-4	-104	-1.1565E-3	-59	-4.3936E-3	-14	-2.1364E-2
-193	-3.2485E-6	-148	-2.4265E-4	-103	-1.1830E-3	-58	-4.4943E-3	-13	-2.2108E-2
-192	-4.1927E-6	-147	-2.6363E-4	-102	-1.2094E-3	-57	-4.6534E-3	-12	-2.2903E-2
-191	-5.2330E-6	-146	-2.8507E-4	-101	-1.2384E-3	-56	-4.8055E-3	-11	-2.3699E-2
-190	-6.3624E-6	-145	-3.0682E-4	-100	-1.2656E-3	-55	-4.9620E-3	-10	-2.4490E-2
-189	-7.5769E-6	-144	-3.2875E-4	-99	-1.3118E-3	-54	-5.1295E-3	-9	-2.5381E-2
-188	-8.8773E-6	-143	-3.5072E-4	-98	-1.3234E-3	-53	-5.2895E-3	-8	-2.6111E-2
-187	-1.0257E-5	-142	-3.7264E-4	-97	-1.3574E-3	-52	-5.4567E-3	-7	-2.6931E-2
-186	-1.1710E-5	-141	-3.9440E-4	-96	-1.3948E-3	-51	-5.6276E-3	-6	-2.7752E-2
-185	-1.3230E-5	-140	-4.1592E-4	-95	-1.4350E-3	-50	-5.8072E-3	-5	-2.8572E-2
-184	-1.4811E-5	-139	-4.3716E-4	-94	-1.4783E-3	-49	-6.0256E-3	-4	-2.9386E-2
-183	-1.6448E-5	-138	-4.5823E-4	-93	-1.5223E-3	-48	-6.2159E-3	-3	-3.0192E-2
-182	-1.8134E-5	-137	-4.8052E-4	-92	-1.5682E-3	-47	-6.4213E-3	-2	-3.0988E-2
-181	-1.9867E-5	-136	-5.0178E-4	-91	-1.6152E-3	-46	-6.6318E-3	-1	-3.1771E-2
-180	-2.1640E-5	-135	-5.2256E-4	-90	-1.6627E-3	-45	-6.8501E-3	0	-3.2540E-2
-179	-2.3453E-5	-134	-5.4289E-4	-89	-1.7252E-3	-44	-7.0819E-3		
-178	-2.5315E-5	-133	-5.6275E-4	-88	-1.7756E-3	-43	-7.3097E-3		
-177	-2.7219E-5	-132	-5.8214E-4	-87	-1.8328E-3	-42	-7.5451E-3		
-176	-2.9162E-5	-131	-6.0105E-4	-86	-1.8915E-3	-41	-7.8381E-3		
-175	-3.1138E-5	-130	-6.1945E-4	-85	-1.9579E-3	-40	-8.1133E-3		
-174	-3.3144E-5	-129	-6.3738E-4	-84	-2.0186E-3	-39	-8.4205E-3		
-173	-3.5175E-5	-128	-6.5494E-4	-83	-2.0824E-3	-38	-8.6982E-3		
-172	-3.7227E-5	-127	-6.7212E-4	-82	-2.1489E-3	-37	-9.0030E-3		
-171	-3.9297E-5	-126	-6.8899E-4	-81	-2.2168E-3	-36	-9.3261E-3		
-170	-4.1382E-5	-125	-7.0721E-4	-80	-2.2855E-3	-35	-9.6454E-3		
-169	-4.3481E-5	-124	-7.2421E-4	-79	-2.3575E-3	-34	-1.0014E-2		
-168	-4.5603E-5	-123	-7.4065E-4	-78	-2.4293E-3	-33	-1.0361E-2		
-167	-4.7745E-5	-122	-7.5662E-4	-77	-2.5069E-3	-32	-1.0734E-2		
-166	-4.9902E-5	-121	-7.7215E-4	-76	-2.5839E-3	-31	-1.1126E-2		
-165	-5.2071E-5	-120	-7.8734E-4	-75	-2.6612E-3	-30	-1.1528E-2		
-164	-5.4250E-5	-119	-8.0548E-4	-74	-2.7400E-3	-29	-1.2035E-2		
-163	-5.6434E-5	-118	-8.2250E-4	-73	-2.8166E-3	-28	-1.2445E-2		
-162	-5.8882E-5	-117	-8.4118E-4	-72	-2.8941E-3	-27	-1.2949E-2		
-161	-6.7272E-5	-116	-8.6075E-4	-71	-2.9738E-3	-26	-1.3468E-2		
-160	-7.2937E-5	-115	-8.8115E-4	-70	-3.0501E-3	-25	-1.4015E-2		
-159	-7.8597E-5	-114	-9.0252E-4	-69	-3.1574E-3	-24	-1.4599E-2		
-158	-8.5887E-5	-113	-9.2678E-4	-68	-3.2456E-3	-23	-1.5191E-2		
-157	-9.5252E-5	-112	-9.5079E-4	-67	-3.3528E-3	-22	-1.5793E-2		
-156	-1.0656E-4	-111	-9.7528E-4	-66	-3.4663E-3	-21	-1.6418E-2		

Table 2. Future biogenic carbon (C_{bio}) fixation factors in $t C_{\text{bio}} \text{ yr}^{-1}$ over a maximum rotation length of 200 years

yr	$t C_{\text{bio}} \cdot \text{yr}^{-1}$	yr	$t C_{\text{bio}} \cdot \text{yr}^{-1}$	yr	$t C_{\text{bio}} \cdot \text{yr}^{-1}$	yr	$t C_{\text{bio}} \cdot \text{yr}^{-1}$	yr	$t C_{\text{bio}} \cdot \text{yr}^{-1}$
0	-7.5020E-4	45	-1.2957E-2	90	-2.3455E-3	135	-9.3193E-4	180	-1.3466E-4
1	-7.5679E-4	46	-1.2974E-2	91	-2.3155E-3	136	-9.2938E-4	181	-1.3442E-4
2	-1.3531E-3	47	-1.3033E-2	92	-2.3086E-3	137	-9.2680E-4	182	-1.3418E-4
3	-2.0956E-3	48	-1.2674E-2	93	-2.3016E-3	138	-9.2419E-4	183	-1.3394E-4
4	-2.9539E-3	49	-1.2711E-2	94	-2.2946E-3	139	-9.1815E-4	184	-1.3370E-4
5	-3.9067E-3	50	-1.1308E-2	95	-2.1995E-3	140	-7.1356E-4	185	-1.3345E-4
6	-4.9356E-3	51	-1.0587E-2	96	-2.1943E-3	141	-7.1130E-4	186	-1.3319E-4
7	-6.0243E-3	52	-1.0607E-2	97	-2.1891E-3	142	-7.0902E-4	187	-1.3294E-4
8	-7.1579E-3	53	-1.0622E-2	98	-2.1034E-3	143	-7.0673E-4	188	-1.3268E-4
9	-8.3228E-3	54	-1.0162E-2	99	-2.0981E-3	144	-7.0443E-4	189	-1.3242E-4
10	-9.0555E-3	55	-9.0962E-3	100	-1.8611E-3	145	-6.9905E-4	190	-1.2433E-4
11	-1.0183E-2	56	-9.0878E-3	101	-1.8573E-3	146	-6.9676E-4	191	-1.2408E-4
12	-1.1309E-2	57	-9.0767E-3	102	-1.8535E-3	147	-6.9446E-4	192	-1.2382E-4
13	-1.2424E-2	58	-8.7384E-3	103	-1.8361E-3	148	-6.9214E-4	193	-1.2357E-4
14	-1.3522E-2	59	-8.5835E-3	104	-1.8325E-3	149	-6.8982E-4	194	-1.2331E-4
15	-1.4199E-2	60	-6.8758E-3	105	-1.7964E-3	150	-3.4721E-4	195	-1.2305E-4
16	-1.4211E-2	61	-6.8554E-3	106	-1.7164E-3	151	-3.4443E-4	196	-1.2279E-4
17	-1.5168E-2	62	-6.8281E-3	107	-1.7133E-3	152	-3.4385E-4	197	-1.2252E-4
18	-1.6095E-2	63	-6.8057E-3	108	-1.7102E-3	153	-3.4325E-4	198	-1.2226E-4
19	-1.6991E-2	64	-6.7822E-3	109	-1.7070E-3	154	-3.4265E-4	199	-1.2199E-4
20	-1.6613E-2	65	-5.9234E-3	110	-1.5543E-3	155	-3.4203E-4	200	0.0000E+0
21	-1.7414E-2	66	-5.7354E-3	111	-1.5508E-3	156	-3.4141E-4		
22	-1.8183E-2	67	-5.6130E-3	112	-1.5473E-3	157	-3.4078E-4		
23	-1.8919E-2	68	-5.5856E-3	113	-1.5437E-3	158	-3.4013E-4		
24	-1.9048E-2	69	-5.5578E-3	114	-1.4637E-3	159	-3.3948E-4		
25	-1.9275E-2	70	-4.6162E-3	115	-1.4287E-3	160	-1.7288E-4		
26	-1.9897E-2	71	-4.5883E-3	116	-1.4258E-3	161	-1.7251E-4		
27	-2.0486E-2	72	-4.2611E-3	117	-1.4229E-3	162	-1.7215E-4		
28	-2.0696E-2	73	-4.2346E-3	118	-1.4199E-3	163	-1.6366E-4		
29	-2.1229E-2	74	-4.2079E-3	119	-1.4169E-3	164	-1.6347E-4		
30	-1.7333E-2	75	-4.0691E-3	120	-1.2375E-3	165	-1.6326E-4		
31	-1.7711E-2	76	-4.0446E-3	121	-1.2349E-3	166	-1.6305E-4		
32	-1.8066E-2	77	-4.0201E-3	122	-1.1819E-3	167	-1.6284E-4		
33	-1.8400E-2	78	-3.8910E-3	123	-1.1793E-3	168	-1.6262E-4		
34	-1.8480E-2	79	-3.7195E-3	124	-1.1767E-3	169	-1.6239E-4		
35	-1.6965E-2	80	-3.3894E-3	125	-1.1693E-3	170	-1.5000E-4		
36	-1.6828E-2	81	-3.3698E-3	126	-1.1666E-3	171	-1.4978E-4		
37	-1.6287E-2	82	-3.3503E-3	127	-1.1587E-3	172	-1.4956E-4		
38	-1.6481E-2	83	-3.3309E-3	128	-1.1561E-3	173	-1.4933E-4		
39	-1.6661E-2	84	-3.2260E-3	129	-1.1534E-3	174	-1.4910E-4		
40	-1.5169E-2	85	-3.0888E-3	130	-9.4843E-4	175	-1.4887E-4		
41	-1.5303E-2	86	-2.7642E-3	131	-9.4595E-4	176	-1.4863E-4		
42	-1.5064E-2	87	-2.7536E-3	132	-9.4345E-4	177	-1.4838E-4		
43	-1.4534E-2	88	-2.7430E-3	133	-9.4092E-4	178	-1.4813E-4		
44	-1.4034E-2	89	-2.7325E-3	134	-9.3837E-4	179	-1.4788E-4		

Appendix F: SM of Paper 3

This Appendix contains the **Supplementary Material of Paper 3** (section 5.2): Modelling dynamic soil organic carbon flows of annual and perennial energy crops to inform energy-transport policy scenarios in France

1 Pre-treatment of techno-economic data for the coupling

1.1 Details on the biomass commodities outputs from the techno-economic model

The following considered dedicated annual and perennial energy crops, including residues, associated with the techno-economic outputs of biomass commodity supply the transport sub-sector, are listed in Table 1.

Table 1. Specifications of analysed energy crops in TIMES-MIRET

Country	Energy crop	Feature	Crop type	Biomass commodity	Commodity type	TIMES-MIRET Code
France	Wheat	Annual	Grain	Starch	D	BIOSTAWHE
			Grain	Straw	R	BIOWHE
France	Rapeseed	Annual	Oil crops	Oil	D	BIOOILRAP
				Straw	R	BIOWHE
France	Maize	Annual	Grain	Starch	D	BIOSTACOR
				Straw	R	BIOWHE
France	Sunflower	Annual	Oil crops	Oil	D	BIOOILSUN
France	Triticale	Annual	Grain	Starch	D	BIOSTATRI
				Straw	R	BIOWHE
France	Sugar beet	Annual	Vegetable	Sugar	D	BIOSUGFS
France	Miscanthus	Perennial	LGC grass	LGC	D	BIOLGCMIS
France	Other LGC (Switch grass)	Perennial	LGC grass	LGG	D	BIOLGCOTH
Brazil	Soybean	Annual	Protein crops	Oil	D	BIOOILSOY

D = Dedicated; R = Residue; LGC = Lignocellulose

1.2 Data on chemical composition of energy crops

Table 2. Nutritional values and equivalent residual fraction

Energy crops	Fresh matter $t \cdot t^{-1}$	Starch $t \cdot ha^{-1}$	Sugar $t \cdot ha^{-1}$	Oil $t \cdot ha^{-1}$	
Maize	0.8630	0.6380	0.0170	0.0360	a
Rapeseed	0.9240	0.0360	0.0550	0.4400	a
Wheat	0.8780	0.5630	0.0280	0.0180	a
Triticale	0.8680	0.5880	0.0300	0.0120	a
Sunflower	0.9280	0.0120	0.0250	0.4460	a
Sugar beet	N/A	N/A	0.1750	N/A	b
Soybean	0.8950	0.0520	0.0750	0.1840	a

Sources: a (INRA-CIRAD-AFZ, 2017), b (Zabed et al., 2017)

1.3 Computation of land occupation requirements

Calculation of land occupation of biomass commodities outputs from the techno-economic model supply associated with dedicated annual crops and perennial grasses as well as residual straw is carried out by means of Eq. 1 to Eq. 2. The computation is based on yield proportions (crop products or residual) as well as corresponding chemical contents (starch, sugar or oil), retained from Table 2.

$$\text{Annual crops [ha]} = \frac{\text{Biomass commodity [t]}}{\text{Commodity chemical content [\%]} \times \text{Crop yield [t} \cdot \text{ha}^{-1}\text{]}} \quad \text{Eq. 1}$$

$$\text{Perennial grasses [ha]} = \frac{\text{Biomass commodity [t]}}{\text{Crop yield [t} \cdot \text{ha}^{-1}\text{]}} \quad \text{Eq. 2}$$

$$\text{Residues [ha]} = \frac{\text{Biomass commodity [t]}}{\text{Removal yield [\%]} \times \text{Residue yield [t} \cdot \text{ha}^{-1}\text{]}} \quad \text{Eq. 3}$$

1.4 Computation of final energy supply

1.4.1 Biofuel supply and greenhouse gas emissions

Conversion factors concerning low heating values (LHV) and biofuel yields per biomass commodity and biofuel pathways, as well as GHG emission factors are estimated from the Well-To-Wheel (WTW) method for transport fuels by the scientific reference of the European Commission Joint Research Centre (EC-JRC) (Edwards et al., 2014) and adjusted to wet matter. The latter provides a relevant widely used assessment, although it does not involve emission from building facilities, vehicle productions nor end-of-life paths (<https://ec.europa.eu/jrc/en/jec/activities/wtw>).

Finally, we re-expressed all CO₂-eq values into CO₂, CH₄ and N₂O elementary flows based on the proportional values provided in the EC-JRC report appendices (Edwards et al., 2014) and IPCC Global Warming Potentials (GWP) factors (Myhre et al., 2013). The fossil-sourced GHG inventories per biomass-to-biofuel pathway form part of the complete dynamic carbon balance (fossil + biogenic), were assessed with the dynamic LCA method by Levasseur et al. (2010).

Low heating value (LHV) estimates, in MJ·kg⁻¹, for bioethanol is 27 and for biodiesel 37 (Edwards et al., 2014). Yield efficiencies vary for bioethanol between 0.31 and 0.62 kg_{Ethanol}·kg_{Grain}⁻¹, and less for biodiesel between 0.99 and 1 MJ_{Biodiesel}·MJ_{Oil}⁻¹, as shown in Table 3.

Table 3. Ethanol and Biodiesel yields

	Ehtanol Yield [kg _{EtoH} ·kg _{Grain} DM ⁻¹]		Biodiesel Yield [MJ _{BioDSL} ·MJ _{Oil} ⁻¹]
Maize	0.62	Rapeseed	1.019
Wheat	0.31	Soybean	0.999
Sugar beet	0.33	Sunflower	0.999
Dedicated	0.43	HPOFS*	1.006
Straw	0.43		

*Hydro-treated pyrolysis oil from straw

1.4.2 Computation of greenhouse gas emissions

The following estimates are based on the carbon neutral approach. GHG emissions of bioethanol vary considerably among the different commodities, whereas the emission factor for dedicated (22.8 g CO₂-eq) and residual (9.2 g CO₂-eq) lignocellulose are lower than from sugar beet (40.3 g CO₂-eq), wheat (69.4 g CO₂-eq) or maize (80.3 g CO₂-eq). Biodiesel GHG emissions from oleaginous crops range between 46 to 55 g CO₂-eq. The emission factor 11.5 g CO₂-eq by O'Connell et al., (2019) was considered in the LTECV scenario for hydro treated pyrolysis of oil from residual straw given pathway. IPCC GWP factors are used: 1 g of CO₂-eq per 1 g CO₂, 28 g of CO₂-eq per 1 g CH₄ and 265 g of CO₂-eq per 1 g N₂O (Myhre et al., 2013).

Table 4. Well-to-wheels GHG emission factors in gCO₂eq·MJ⁻¹, including carbon dioxide (CO₂), methane (CH₄) and nitrous oxides (N₂O) proportions

	Code	g CO ₂ eq·MJ ⁻¹	CO ₂	CH ₄	N ₂ O
EU sugar beet to ethanol	SBET1a	40.3	83%	5%	12%
EU wheat to ethanol	WTET1a	69.4	70%	4%	25%
Corn (maize) (average used in EU) to ethanol	CRET2a	80.31	71%	5%	24%
EU farmed (WF) or waste (WW) wood to ethanol	WFET1	22.8	85%	3%	12%
EU wheat straw to ethanol	STET1	9.19	94%	3%	3%
Rapeseed to biodiesel (Rapeseed Methyl Ester)	ROFA1	53.88	50%	3%	47%
Sunflower to biodiesel (Sunflower seed Methyl Ester)	SOFA3	45.9	51%	3%	46%
Soybeans to biodiesel (Soy Methyl ester)	SYFA3a	55.13	50%	3%	47%

Source: (Edwards et al., 2014)

2 Soil organic carbon modelling

2.1 Structure of the model

The structure of the two-compartment model adopted from Hénin and Dupuis (1945) is illustrated in Fig. 1.

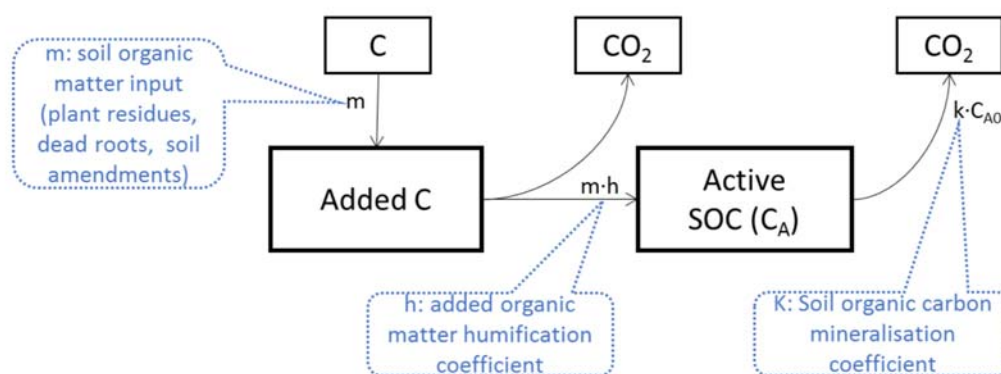

Fig. 1. Carbon pools and transfer equations for dynamic soil organic carbon modelling (adapted from Hénin and Dupuis (1945) and Saffih-Hdadi and Mary (2008))

2.2 Review mineralisation coefficient

The mineralisation coefficient k represents the annual decay of soil organic carbon, that is to say the rate of humus destroyed every year. In France the mean ratio is often estimated at 2% (Frisque, 2007; Le Villio et al., 2001; UNIFA, 1998). A review of several studies indicated a range for France between 0.7% and 9%, with mean values at 4% (Table 5).

Table 5. Reference values for mineralisation coefficient

Country	Type of soil	Climate	Mineralisation k coefficient [y ⁻¹]	
Sweden	Clay loam	Climate Ultuna	0.019	a
Denmark	Sandy loam	Climate Askov	0.044	a
France	Calcareous clay	Climate Issoudun	0.033	a
France	Sandy clay loam	Climate Grignon	0.038	a
France	Clay loam	Climate Boigneville	0.050	a
France	Sandy loam	Climate Serreslous	0.094	a
France	Sandy loam	Climate Doazit	0.090	a
Thailand	Sand	Climate Khon Kaend	0.348	a
Denmark	Sandy loam	Climate Askov	0.043	a
France	Neutral sandy	N/A	0.020	b
France	acidic sand	N/A	0.010	b
France	sandy limestone	N/A	0.017	b
France	N/A	Climate Picardie	0.092	c
France	medium silt	N/A	0.016	b
France	N/A	Climate Picardie	0.074	c
France	clay silt	N/A	0.013	b
France	limestone silt	N/A	0.009	b
France	N/A	Climate Picardie	0.059	c
France	clay	N/A	0.010	b
France	N/A	Climate Picardie	0.041	c
France	N/A	mean annual temperature	0.070	d

Appendices

France	Clay-limestone	N/A	0.007	b
France	N/A	Climate Picardie	0.048	c
France	limestone	Climate Picardie	0.037	c
France	Pergamino soil series	N/A	0.070	e
France		Temperate general	0.020	bf
France		Mediterranean general	0.030	bf
Argentina	N/A	N/A	0.060	g
Brazil	N/A	N/A	0.100	g

Sources : a. (Saffih-Hdadi and Mary, 2008), b. (Le Villio et al., 2001), c. (Duparque et al., 2007a) d. (Moreno et al., 2016), e. (Irizar et al., 2015), f. (Henin and Dupuis, 1945) g. (Piccolo et al., 2008).

To compute the k coefficient we used Eq. 4 of the AMGv2 model (Clivot et al., 2019), dependent on soil temperature (T), clay content (A) and calcium carbonate (CaCO_3):

$$K = K_0 f_1(T) f_2(A) f_3(\text{CaCO}_3) \quad \text{Eq. 4}$$

with $K_0 = 0.290 \text{ [yr}^{-1}\text{]}$.

$K_0 \text{ [yr}^{-1}\text{]}$ is the potential mineralisation rate in the reference condition, ranging between 0.165 and 0.290 $\text{[yr}^{-1}\text{]}$. The formulation for temperature in Eq. 5 allows accounting for a quasi-exponential effect of mean temperature in France (up to 25°C).

$$f_1(T) = \frac{a_T}{1 + (a_T - 1) \exp(c_T \times T_{\text{Ref}}) \exp(c_T \times T)} \quad \text{if } T \geq 0, \quad \text{Eq. 5}$$

$$f_1(T) = 0 \quad \text{if } T < 0.$$

with $a_T = 25$, $c_T = 0.120 \text{K}^{-1}$ and $T_{\text{Ref}} = 15^\circ\text{C}$

The effect of clay (A) content $[\text{g} \cdot \text{g}^{-1} \text{ soil}]$ on mineralisation is described by an exponential law, according to Eq. 6, with constant a $[\text{g} \cdot \text{g}^{-1} \text{ soil}]$ assumed to be 2.519 (Clivot et al., 2019).

$$f_2(A) = \exp(-a_m A) \quad \text{Eq. 6}$$

The effect of calcium carbonate (CaCO_3) is computed with Eq. 7.

$$f_3(\text{CaCO}_3) = \frac{1}{1 + c_m \text{CaCO}_3} \quad \text{Eq. 7}$$

with $c_m = 1.67$ and $1.50 \text{ [g} \cdot \text{g}^{-1} \text{ soil}]$

2.2.1 Soil texture, soil type and climate typology of France

Data for clay contents in France according to main soil texture and types are listed in Table 6.

Table 6. Clay content according to main soil texture and types in France

Soil texture	Soil type	Clay (%)		Sand (%)		Silt (%)	
		min	max	min	max	min	max
Clayey	Clay	30	55	55	70	55	80
	Silty clay	30	55	55	70	80	100
	Heavy clay	45	0	0	55	0	100
	Sandy clay	25	55	55	75	0	55
Silty	Clayey silt	18	70	70	82	85	100
	Medium silt	8	82	82	92	85	100
	Light silt	0	92	92	100	85	100
Balanced	Light sandy silt	0	92	92	100	45	85
	Clayey-sandy silt	18	70	70	82	65	85
	Medium sandy silt	8	82	82	92	65	85
	Sandy silt	8	82	82	92	45	65
	Sandy-clayey silt	18	70	70	82	45	65
Sandy	Sand	0	90	90	100	0	20
	Clayey sand	10	75	75	90	0	45
	Silty sand	0	88	88	100	20	45

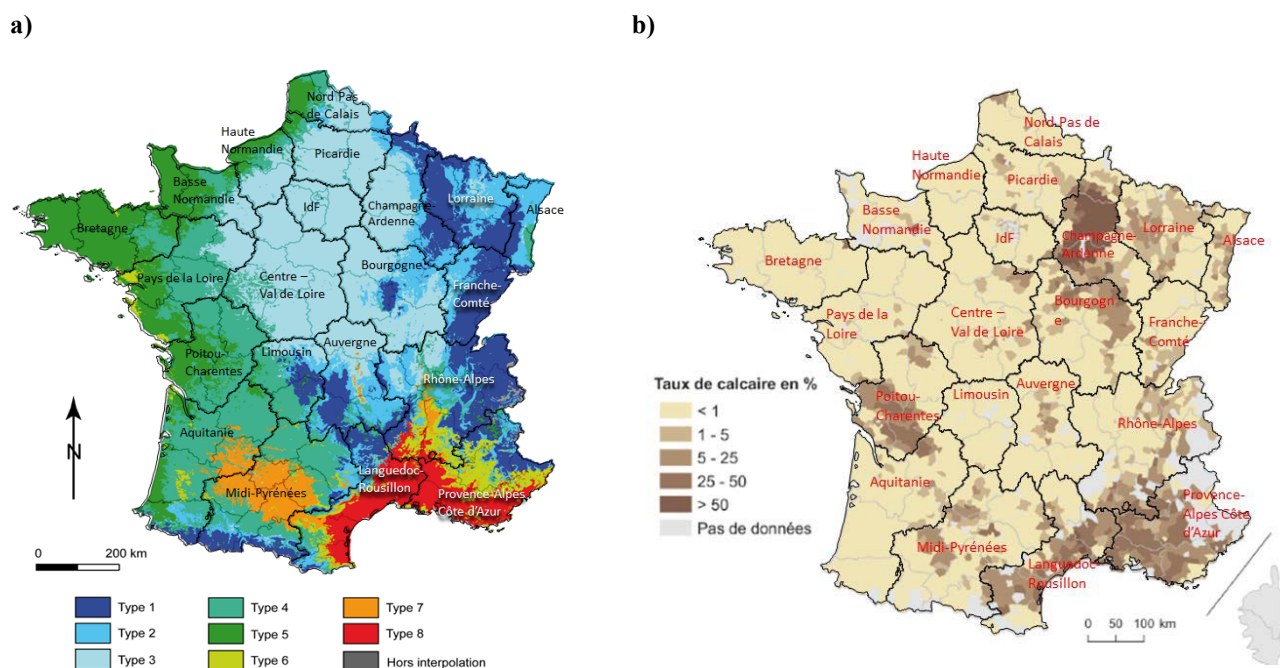

Fig. 3. a) Climate typology of the French territory in 8 classes, adapted from Joly et al. (2010), and b) Calcium carbonate content [%] concerning calcium carbonate [CaCO₃] of agricultural soils in France, adapted from Gis Sol (2011)

2.2.2 Calculated values for national crops

Mineralisation coefficient k is based on mean clay content and climatic typology computed with Eq. 4 to Eq. 6. Results from the computation are given in Table 7 for all climatic types of France. Assumption for the coupling: Consideration of the mineralisation constant for type 3 due to the largest area of cereals and oily seeds production in France.

Table 7. Climate typology in France with mean temperature, clay and calcium carbonate contents to calculate the soil mineralisation coefficient

Type	Name	Temperature [°C]	Clay [%]	Calcium carbonate [%]	Mineralisation coefficient (<i>k</i>) [<i>y</i> ⁻¹]
Type 1	Mountain climate	9	18.5	5	0.0841
Type 2	Semi-continental climate and mountain margin climate	10	25.2	5	0.0799
Type 3	Degraded oceanic climate of the Central and Northern Plains	11	16.8	1	0.1176
Type 4	Altered oceanic climate	12.5	22.0	5	0.1160
Type 5	Oceanic climate	12.5	14.9	1	0.1470
Type 6	Altered Mediterranean climate	12.5	15.6	35	0.0961
Type 7	Climate of the South-western Basin	13	42.6	5	0.0731
Type 8	Mediterranean climate	13	15.6	35	0.1018

2.2.3 Calculated values for imported soybean

The *k* coefficient of imported soybean is also based Eq. 4 to Eq. 6, with reference soil temperature at 27°C, representing about 2°C higher temperature of surface soils in soybean cropland (Nagy et al., 2018).

Table 8. Mean temperature and clay content to calculate the mineralisation coefficient

Country	Crop	Temperature [°C]	Clay [%]	Calcium carbonate [%]	Mineralisation coefficient (<i>k</i>) [<i>y</i> ⁻¹]
Brazil	Soybean	25	43	4	0.07332

Sources: (Ensinas et al., 2016; Nagy et al., 2018)

3. Calculation of plant carbon allocation and soil organic carbon inputs

3.1 Relative plant C allocation coefficients

$$R_p + R_s + R_r + R_e = 1$$

Eq. 3

Table 9. Relative plant carbon (C) allocation coefficients

Crop	Yield ^a Y _i [t ha ⁻¹]	Relative plant C allocation coefficients ^b			
		RP	RS	RR	RE
Wheat	6.410	0.298	0.426	0.166	0.11
Rapeseed	11.980	0.107	0.576	0.191	0.126
Maize	22.788	0.325	0.352	0.194	0.129
Sunflower	3.655	0.360	0.540	0.100	0.000
Triticale	3.479	0.260	0.506	0.142	0.092
Sugar beet	95.240	0.872	0.048	0.048	0.032
Soybean	2.720	0.304	0.455	0.146	0.095
Miscanthus	15.714	0.268	0.303	0.322	0.107
Switchgrass (proxy grass species)	5.190	0.441	0.000	0.308	0.200

Sources: ^a (Besnard et al. 2014; Strullu et al. 2014; Cattelan and Dall'Agnol 2018; AGRESTE 2019), ^b (Bolinder et al. 2007b; Strullu 2011; Strullu et al. 2014; Wiesmeier et al. 2014 (from 1995 to 2010); Agostini et al. 2015; Carvalho et al. 2017), for miscanthus aboveground inputs between 40% and 67% (Carvalho et al., 2017; Strullu, 2011; Strullu et al., 2014) and perennial belowground proportions of rhizomes 75% and roots 25% (Agostini et al., 2015).

Descriptions of sub-indices: P - agricultural aboveground product, S - residual aboveground compartment, R - root/rhizome tissue, E - extra-root material

3.2 Net primary productivity

The C proportion in four plant fractions is defined by Eq. 9 (M. A. Bolinder et al., 2007):

$$\text{NPP} = C_P + C_S + C_R + C_E \quad \text{Eq. 4}$$

For this study, the carbon content of the product (C_P) was calculated from mean annual yield values of the product (Y_p) and the respective carbon content (C_y) given in Eq. 10. The proportions of the other crop plant fractions are estimated by means of the relative plant C allocation coefficients Table 9 respectively applying Eq. 11 to Eq. 13 (Wiesmeier et al., 2014).

$$C_P = Y_p \times C_y \quad \text{Eq. 10}$$

$$C_S = \left(\frac{R_S}{R_P} \right) \times C_P \quad \text{Eq. 11}$$

$$C_R = \left(\frac{R_R}{R_P} \right) \times C_P \quad \text{Eq. 12}$$

$$C_E = \left(\frac{R_E}{R_P} \right) \times C_P \quad \text{Eq. 13}$$

3.3 Details on exogenous inputs

Organic soil amendment/fertiliser input is estimated based on the following data and assumptions.

Table 10. N content of main organic fertilisers used in France

Organic amendments	use in France (contribution) %	Average N content kg·t ⁻¹
Cattle manure and slurry	59%	a 4.4 b
Poultry manure and droppings	11%	a 17.4 b
Swine manure and slurry	10%	a 5.4 b
Others (compost as proxy)	20%	a 11.6 b

Sources: a (AGRESTE, 2014), b (Avadí, 2019)

Table 11. National French averages of N inputs to crops (representing the organic fertiliser inputs to the average ha of crop)

	N requirements of crops from exclusively mineral sources kg·ha ⁻¹	N requirements of crops from mineral sources kg·ha ⁻¹	N requirements of crops from organic sources t·ha ⁻¹	Cattle manure and slurry delivered t·ha ⁻¹	Poultry manure and droppings delivered t·ha ⁻¹	Swine manure and slurry delivered t·ha ⁻¹	Compost delivered t·ha ⁻¹	Percentage of crops applying organic fertilisers %
Wheat	169	140	81	0.82	0.04	0.11	0.10	8%
Triticale	107	87	122	5.26	0.25	0.72	0.67	32%
Maize	133	92.5	144	11.07	0.52	1.51	1.41	57%
Rapeseed	169	153	87	3.99	0.19	0.55	0.51	34%
Sugar beet	123	95	126	9.52	0.45	1.30	1.21	56%
Sunflower	56	45	124	2.84	0.13	0.39	0.36	17%
Miscanthus	52	21	31	1.51	0.07	0.21	0.19	36%
Switch grass	65	38	27	0.98	0.05	0.13	0.13	27%
Sources	a	a	a	b	b	b	b	a

Sources: a (AGRESTE, 2014), b Computed from average N contents, % of crops applying organic fertilisation, and contribution of organic fertilisers to national use Table 11

The input of organic fertiliser (*i*) per energy crop (*j*) is computed by means of Eq. 14:

$$\mathbf{Input\ Fertiliser}_{organic_{ij}} = \mathbf{Fertiliser}_{organic_{ij}} \times \mathbf{crop}_i \mathbf{applying\ Fertiliser}_{organic_j}(\%) \quad \text{Eq. 14}$$

$$\mathbf{Fertiliser}_{organic_{ij}} = \frac{N_{organic_j} \times \mathbf{Fertiliser}_{organic_j} \text{ use in the country of origin } (\%)}{\text{Mean } N_i \text{ content}}$$

3.4 Correction factor for carbon inputs to the soil

The carbon inputs (*C_i*) per plant fraction may be adjusted by means of correction factors (*S*), according to Eq. 15 (Wiesmeier et al., 2012) as not all the crop plant fractions return to the soil.

$$\mathbf{C}_i = (\mathbf{C}_P \times \mathbf{S}_P) + (\mathbf{C}_S \times \mathbf{S}_S) + (\mathbf{C}_R \times \mathbf{S}_R) + (\mathbf{C}_E \times \mathbf{S}_E) \quad \text{Eq. 15}$$

4 Computed time-dynamic soil organic carbon flows per management scenario

4.1 Scenario 1: Aboveground, Belowground and Exogenous inputs

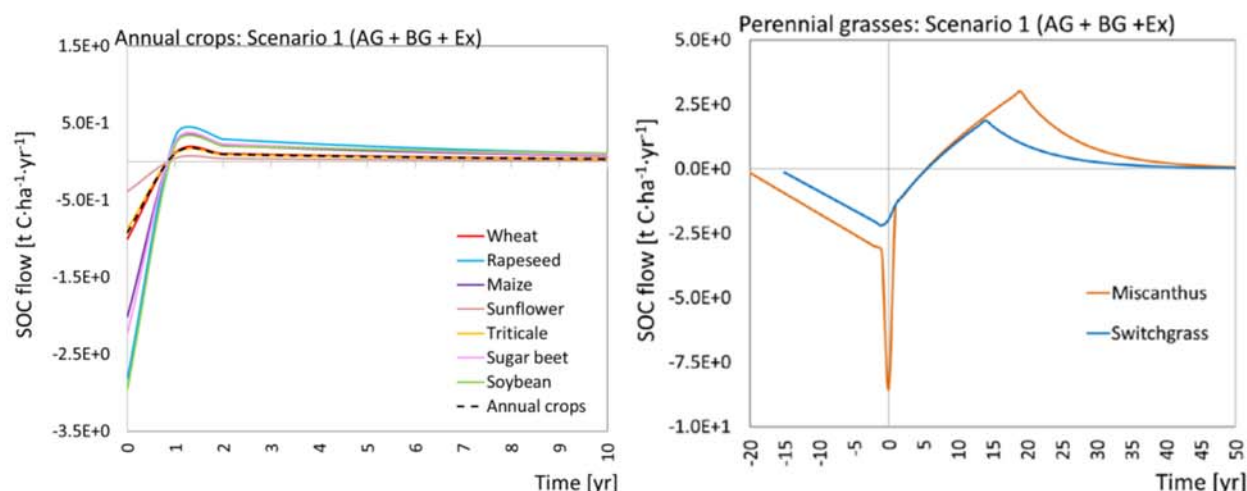

Fig. 4. Scenario 1 annual soil organic carbon elementary flows of annual crops and perennial grasses

Table12. Scenario 1 SOC flows [t C·ha⁻¹·yr⁻¹]

	Annual Crops								Perennial grasses	
	Total annual	Wheat	Rape-seed	Maize	Sun-flower	Triticale	Sugar beet	Soy-bean	Miscan-thus	Switch grass
-20	0.000E+0	0.000E+0	0.000E+0	0.000E+0	0.000E+0	0.000E+0	0.000E+0	0.000E+0	-1.588E-1	0.000E+0
-19	0.000E+0	0.000E+0	0.000E+0	0.000E+0	0.000E+0	0.000E+0	0.000E+0	0.000E+0	-3.177E-1	0.000E+0
-18	0.000E+0	0.000E+0	0.000E+0	0.000E+0	0.000E+0	0.000E+0	0.000E+0	0.000E+0	-4.765E-1	0.000E+0
-17	0.000E+0	0.000E+0	0.000E+0	0.000E+0	0.000E+0	0.000E+0	0.000E+0	0.000E+0	-6.353E-1	0.000E+0
-16	0.000E+0	0.000E+0	0.000E+0	0.000E+0	0.000E+0	0.000E+0	0.000E+0	0.000E+0	-7.942E-1	0.000E+0
-15	0.000E+0	0.000E+0	0.000E+0	0.000E+0	0.000E+0	0.000E+0	0.000E+0	0.000E+0	-9.530E-1	-1.465E-1
-14	0.000E+0	0.000E+0	0.000E+0	0.000E+0	0.000E+0	0.000E+0	0.000E+0	0.000E+0	-1.112E+0	-2.930E-1
-13	0.000E+0	0.000E+0	0.000E+0	0.000E+0	0.000E+0	0.000E+0	0.000E+0	0.000E+0	-1.271E+0	-4.396E-1
-12	0.000E+0	0.000E+0	0.000E+0	0.000E+0	0.000E+0	0.000E+0	0.000E+0	0.000E+0	-1.429E+0	-5.861E-1
-11	0.000E+0	0.000E+0	0.000E+0	0.000E+0	0.000E+0	0.000E+0	0.000E+0	0.000E+0	-1.588E+0	-7.326E-1
-10	0.000E+0	0.000E+0	0.000E+0	0.000E+0	0.000E+0	0.000E+0	0.000E+0	0.000E+0	-1.747E+0	-8.791E-1
-9	0.000E+0	0.000E+0	0.000E+0	0.000E+0	0.000E+0	0.000E+0	0.000E+0	0.000E+0	-1.906E+0	-1.026E+0
-8	0.000E+0	0.000E+0	0.000E+0	0.000E+0	0.000E+0	0.000E+0	0.000E+0	0.000E+0	-2.065E+0	-1.172E+0
-7	0.000E+0	0.000E+0	0.000E+0	0.000E+0	0.000E+0	0.000E+0	0.000E+0	0.000E+0	-2.224E+0	-1.319E+0
-6	0.000E+0	0.000E+0	0.000E+0	0.000E+0	0.000E+0	0.000E+0	0.000E+0	0.000E+0	-2.382E+0	-1.465E+0
-5	0.000E+0	0.000E+0	0.000E+0	0.000E+0	0.000E+0	0.000E+0	0.000E+0	0.000E+0	-2.541E+0	-1.612E+0
-4	0.000E+0	0.000E+0	0.000E+0	0.000E+0	0.000E+0	0.000E+0	0.000E+0	0.000E+0	-2.700E+0	-1.758E+0
-3	0.000E+0	0.000E+0	0.000E+0	0.000E+0	0.000E+0	0.000E+0	0.000E+0	0.000E+0	-2.859E+0	-1.905E+0
-2	0.000E+0	0.000E+0	0.000E+0	0.000E+0	0.000E+0	0.000E+0	0.000E+0	0.000E+0	-3.018E+0	-2.051E+0
-1	0.000E+0	0.000E+0	0.000E+0	0.000E+0	0.000E+0	0.000E+0	0.000E+0	0.000E+0	-3.177E+0	-2.198E+0
0	-9.214E-1	-1.003E+0	-2.819E+0	-2.011E+0	-3.856E-1	-8.716E-1	-2.227E+0	-2.956E+0	-8.561E+0	-1.970E+0
1	1.084E-1	1.180E-1	3.315E-1	2.365E-1	4.535E-2	1.025E-1	2.619E-1	2.167E-1	-1.460E+0	-1.397E+0
2	9.562E-2	1.041E-1	2.925E-1	2.087E-1	4.002E-2	9.045E-2	2.311E-1	2.008E-1	-1.092E+0	-1.052E+0
3	8.437E-2	9.184E-2	2.581E-1	1.842E-1	3.531E-2	7.982E-2	2.039E-1	1.861E-1	-7.487E-1	-7.300E-1
4	7.445E-2	8.104E-2	2.278E-1	1.625E-1	3.116E-2	7.043E-2	1.800E-1	1.725E-1	-4.271E-1	-4.287E-1
5	6.569E-2	7.151E-2	2.010E-1	1.434E-1	2.749E-2	6.215E-2	1.588E-1	1.598E-1	-1.246E-1	-1.456E-1
6	5.797E-2	6.310E-2	1.773E-1	1.265E-1	2.426E-2	5.484E-2	1.401E-1	1.481E-1	1.610E-1	1.214E-1
7	5.115E-2	5.568E-2	1.565E-1	1.117E-1	2.141E-2	4.839E-2	1.236E-1	1.372E-1	4.316E-1	3.743E-1
8	4.513E-2	4.913E-2	1.381E-1	9.852E-2	1.889E-2	4.270E-2	1.091E-1	1.272E-1	6.891E-1	6.146E-1
9	3.983E-2	4.335E-2	1.218E-1	8.694E-2	1.667E-2	3.768E-2	9.626E-2	1.178E-1	9.350E-1	8.439E-1
10	3.514E-2	3.825E-2	1.075E-1	7.671E-2	1.471E-2	3.324E-2	8.494E-2	1.092E-1	1.171E+0	1.064E+0

Appendices

11	3.101E-2	3.375E-2	9.486E-2	6.769E-2	1.298E-2	2.933E-2	7.495E-2	1.012E-1	1.397E+0	1.275E+0
12	2.736E-2	2.978E-2	8.371E-2	5.973E-2	1.145E-2	2.588E-2	6.614E-2	9.378E-2	1.616E+0	1.478E+0
13	2.414E-2	2.628E-2	7.386E-2	5.270E-2	1.010E-2	2.284E-2	5.836E-2	8.690E-2	1.828E+0	1.675E+0
14	2.130E-2	2.319E-2	6.518E-2	4.651E-2	8.916E-3	2.015E-2	5.149E-2	8.053E-2	2.033E+0	1.865E+0
15	1.880E-2	2.046E-2	5.751E-2	4.104E-2	7.868E-3	1.778E-2	4.544E-2	7.462E-2	2.233E+0	1.646E+0
16	1.659E-2	1.806E-2	5.075E-2	3.621E-2	6.942E-3	1.569E-2	4.009E-2	6.915E-2	2.428E+0	1.452E+0
17	1.464E-2	1.593E-2	4.478E-2	3.195E-2	6.126E-3	1.385E-2	3.538E-2	6.408E-2	2.619E+0	1.282E+0
18	1.292E-2	1.406E-2	3.951E-2	2.819E-2	5.405E-3	1.222E-2	3.122E-2	5.938E-2	2.806E+0	1.131E+0
19	1.140E-2	1.241E-2	3.486E-2	2.488E-2	4.770E-3	1.078E-2	2.755E-2	5.503E-2	2.990E+0	9.979E-1
20	1.006E-2	1.095E-2	3.076E-2	2.195E-2	4.209E-3	9.513E-3	2.431E-2	5.099E-2	2.638E+0	8.805E-1
21	8.874E-3	9.659E-3	2.715E-2	1.937E-2	3.714E-3	8.394E-3	2.145E-2	4.725E-2	2.328E+0	7.770E-1
22	7.830E-3	8.523E-3	2.395E-2	1.709E-2	3.277E-3	7.407E-3	1.893E-2	4.379E-2	2.054E+0	6.856E-1
23	6.909E-3	7.521E-3	2.114E-2	1.508E-2	2.892E-3	6.536E-3	1.670E-2	4.058E-2	1.812E+0	6.050E-1
24	6.096E-3	6.636E-3	1.865E-2	1.331E-2	2.551E-3	5.767E-3	1.474E-2	3.760E-2	1.599E+0	5.338E-1
25	5.379E-3	5.856E-3	1.646E-2	1.174E-2	2.251E-3	5.089E-3	1.300E-2	3.485E-2	1.411E+0	4.710E-1
26	4.747E-3	5.167E-3	1.452E-2	1.036E-2	1.987E-3	4.490E-3	1.147E-2	3.229E-2	1.245E+0	4.156E-1
27	4.189E-3	4.559E-3	1.281E-2	9.143E-3	1.753E-3	3.962E-3	1.012E-2	2.992E-2	1.099E+0	3.667E-1
28	3.696E-3	4.023E-3	1.131E-2	8.068E-3	1.547E-3	3.496E-3	8.933E-3	2.773E-2	9.696E-1	3.236E-1
29	3.261E-3	3.550E-3	9.977E-3	7.119E-3	1.365E-3	3.085E-3	7.883E-3	2.570E-2	8.555E-1	2.856E-1
30	2.878E-3	3.132E-3	8.803E-3	6.282E-3	1.204E-3	2.722E-3	6.956E-3	2.381E-2	7.549E-1	2.520E-1
31	2.539E-3	2.764E-3	7.768E-3	5.543E-3	1.063E-3	2.402E-3	6.137E-3	2.207E-2	6.661E-1	2.223E-1
32	2.241E-3	2.439E-3	6.854E-3	4.891E-3	9.377E-4	2.120E-3	5.416E-3	2.045E-2	5.878E-1	1.962E-1
33	1.977E-3	2.152E-3	6.048E-3	4.316E-3	8.274E-4	1.870E-3	4.779E-3	1.895E-2	5.186E-1	1.731E-1
34	1.745E-3	1.899E-3	5.337E-3	3.808E-3	7.301E-4	1.650E-3	4.217E-3	1.756E-2	4.576E-1	1.528E-1
35	1.539E-3	1.676E-3	4.709E-3	3.360E-3	6.443E-4	1.456E-3	3.721E-3	1.627E-2	4.038E-1	1.348E-1
36	1.358E-3	1.479E-3	4.155E-3	2.965E-3	5.685E-4	1.285E-3	3.283E-3	1.508E-2	3.563E-1	1.189E-1
37	1.199E-3	1.305E-3	3.667E-3	2.616E-3	5.016E-4	1.134E-3	2.897E-3	1.397E-2	3.144E-1	1.049E-1
38	1.058E-3	1.151E-3	3.235E-3	2.309E-3	4.426E-4	1.000E-3	2.556E-3	1.295E-2	2.774E-1	9.260E-2
39	9.332E-4	1.016E-3	2.855E-3	2.037E-3	3.906E-4	8.828E-4	2.256E-3	1.200E-2	2.448E-1	8.171E-2
40	8.235E-4	8.963E-4	2.519E-3	1.798E-3	3.446E-4	7.790E-4	1.990E-3	1.112E-2	2.160E-1	7.210E-2
41	7.266E-4	7.909E-4	2.223E-3	1.586E-3	3.041E-4	6.874E-4	1.756E-3	1.030E-2	1.906E-1	6.362E-2
42	6.412E-4	6.979E-4	1.961E-3	1.400E-3	2.683E-4	6.065E-4	1.550E-3	9.548E-3	1.682E-1	5.614E-2
43	5.658E-4	6.158E-4	1.731E-3	1.235E-3	2.368E-4	5.352E-4	1.367E-3	8.848E-3	1.484E-1	4.954E-2
44	4.992E-4	5.434E-4	1.527E-3	1.090E-3	2.089E-4	4.722E-4	1.207E-3	8.199E-3	1.310E-1	4.371E-2
45	4.405E-4	4.795E-4	1.348E-3	9.616E-4	1.844E-4	4.167E-4	1.065E-3	7.598E-3	1.156E-1	3.857E-2
46	3.887E-4	4.231E-4	1.189E-3	8.485E-4	1.627E-4	3.677E-4	9.395E-4	7.041E-3	1.020E-1	3.403E-2
47	3.430E-4	3.733E-4	1.049E-3	7.487E-4	1.435E-4	3.245E-4	8.290E-4	6.525E-3	8.997E-2	3.003E-2
48	3.026E-4	3.294E-4	9.258E-4	6.606E-4	1.267E-4	2.863E-4	7.315E-4	6.046E-3	7.939E-2	2.650E-2
49	2.670E-4	2.907E-4	8.170E-4	5.829E-4	1.118E-4	2.526E-4	6.455E-4	5.603E-3	7.006E-2	2.338E-2
50	2.356E-4	2.565E-4	7.209E-4	5.144E-4	9.862E-5	2.229E-4	5.696E-4	5.192E-3	6.182E-2	2.063E-2

4.2 Scenario 2: Aboveground carbon inputs only

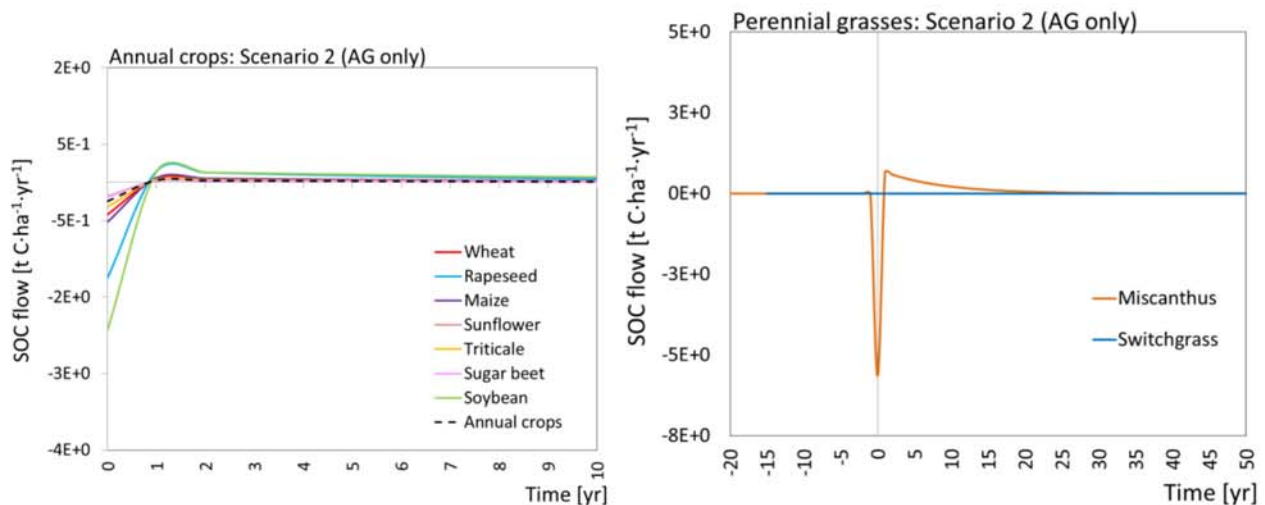

Fig. 5. Scenario 2 annual soil organic carbon elementary flows of annual crops and perennial grasses

Table 13. Scenario 2 SOC flows [t C·ha⁻¹·yr⁻¹]

yr	Annual Crops					Perennial grasses				
	Total Annual	Wheat	Rape-seed	Maize	Sun-flower	Triticale	Sugar beet	Soy-bean	Miscanthus	Switch grass
-20	0.000E+0	0.000E+0	0.000E+0	0.000E+0	0.000E+0	0.000E+0	0.000E+0	0.000E+0	0.000E+0	0.000E+0
-19	0.000E+0	0.000E+0	0.000E+0	0.000E+0	0.000E+0	0.000E+0	0.000E+0	0.000E+0	0.000E+0	0.000E+0
-18	0.000E+0	0.000E+0	0.000E+0	0.000E+0	0.000E+0	0.000E+0	0.000E+0	0.000E+0	0.000E+0	0.000E+0
-17	0.000E+0	0.000E+0	0.000E+0	0.000E+0	0.000E+0	0.000E+0	0.000E+0	0.000E+0	0.000E+0	0.000E+0
-16	0.000E+0	0.000E+0	0.000E+0	0.000E+0	0.000E+0	0.000E+0	0.000E+0	0.000E+0	0.000E+0	0.000E+0
-15	0.000E+0	0.000E+0	0.000E+0	0.000E+0	0.000E+0	0.000E+0	0.000E+0	0.000E+0	0.000E+0	0.000E+0
-14	0.000E+0	0.000E+0	0.000E+0	0.000E+0	0.000E+0	0.000E+0	0.000E+0	0.000E+0	0.000E+0	0.000E+0
-13	0.000E+0	0.000E+0	0.000E+0	0.000E+0	0.000E+0	0.000E+0	0.000E+0	0.000E+0	0.000E+0	0.000E+0
-12	0.000E+0	0.000E+0	0.000E+0	0.000E+0	0.000E+0	0.000E+0	0.000E+0	0.000E+0	0.000E+0	0.000E+0
-11	0.000E+0	0.000E+0	0.000E+0	0.000E+0	0.000E+0	0.000E+0	0.000E+0	0.000E+0	0.000E+0	0.000E+0
-10	0.000E+0	0.000E+0	0.000E+0	0.000E+0	0.000E+0	0.000E+0	0.000E+0	0.000E+0	0.000E+0	0.000E+0
-9	0.000E+0	0.000E+0	0.000E+0	0.000E+0	0.000E+0	0.000E+0	0.000E+0	0.000E+0	0.000E+0	0.000E+0
-8	0.000E+0	0.000E+0	0.000E+0	0.000E+0	0.000E+0	0.000E+0	0.000E+0	0.000E+0	0.000E+0	0.000E+0
-7	0.000E+0	0.000E+0	0.000E+0	0.000E+0	0.000E+0	0.000E+0	0.000E+0	0.000E+0	0.000E+0	0.000E+0
-6	0.000E+0	0.000E+0	0.000E+0	0.000E+0	0.000E+0	0.000E+0	0.000E+0	0.000E+0	0.000E+0	0.000E+0
-5	0.000E+0	0.000E+0	0.000E+0	0.000E+0	0.000E+0	0.000E+0	0.000E+0	0.000E+0	0.000E+0	0.000E+0
-4	0.000E+0	0.000E+0	0.000E+0	0.000E+0	0.000E+0	0.000E+0	0.000E+0	0.000E+0	0.000E+0	0.000E+0
-3	0.000E+0	0.000E+0	0.000E+0	0.000E+0	0.000E+0	0.000E+0	0.000E+0	0.000E+0	0.000E+0	0.000E+0
-2	0.000E+0	0.000E+0	0.000E+0	0.000E+0	0.000E+0	0.000E+0	0.000E+0	0.000E+0	0.000E+0	0.000E+0
-1	0.000E+0	0.000E+0	0.000E+0	0.000E+0	0.000E+0	0.000E+0	0.000E+0	0.000E+0	0.000E+0	0.000E+0
0	-2.457E-1	-4.193E-1	-1.248E+0	-5.170E-1	-1.795E-1	-3.180E-1	-1.903E-1	-1.932E+0	-5.645E+0	0.000E+0
1	2.889E-2	4.931E-2	1.468E-1	6.080E-2	2.111E-2	3.740E-2	2.239E-2	1.417E-1	6.639E-1	0.000E+0
2	2.549E-2	4.351E-2	1.295E-1	5.365E-2	1.863E-2	3.300E-2	1.975E-2	1.313E-1	5.858E-1	0.000E+0
3	2.250E-2	3.839E-2	1.143E-1	4.734E-2	1.644E-2	2.912E-2	1.743E-2	1.217E-1	5.169E-1	0.000E+0
4	1.985E-2	3.388E-2	1.009E-1	4.177E-2	1.451E-2	2.570E-2	1.538E-2	1.127E-1	4.561E-1	0.000E+0
5	1.752E-2	2.989E-2	8.900E-2	3.686E-2	1.280E-2	2.267E-2	1.357E-2	1.045E-1	4.025E-1	0.000E+0
6	1.546E-2	2.638E-2	7.853E-2	3.253E-2	1.129E-2	2.001E-2	1.198E-2	9.681E-2	3.551E-1	0.000E+0
7	1.364E-2	2.328E-2	6.929E-2	2.870E-2	9.966E-3	1.765E-2	1.057E-2	8.971E-2	3.134E-1	0.000E+0
8	1.203E-2	2.054E-2	6.114E-2	2.532E-2	8.794E-3	1.558E-2	9.324E-3	8.314E-2	2.765E-1	0.000E+0
9	1.062E-2	1.812E-2	5.395E-2	2.235E-2	7.760E-3	1.375E-2	8.228E-3	7.704E-2	2.440E-1	0.000E+0
10	9.370E-3	1.599E-2	4.761E-2	1.972E-2	6.847E-3	1.213E-2	7.260E-3	7.139E-2	2.153E-1	0.000E+0
11	8.268E-3	1.411E-2	4.201E-2	1.740E-2	6.042E-3	1.070E-2	6.406E-3	6.616E-2	1.900E-1	0.000E+0
12	7.295E-3	1.245E-2	3.707E-2	1.535E-2	5.331E-3	9.444E-3	5.653E-3	6.131E-2	1.676E-1	0.000E+0
13	6.437E-3	1.099E-2	3.271E-2	1.355E-2	4.704E-3	8.333E-3	4.988E-3	5.681E-2	1.479E-1	0.000E+0
14	5.680E-3	9.695E-3	2.886E-2	1.195E-2	4.151E-3	7.353E-3	4.401E-3	5.264E-2	1.305E-1	0.000E+0
15	5.012E-3	8.554E-3	2.547E-2	1.055E-2	3.663E-3	6.488E-3	3.884E-3	4.878E-2	1.152E-1	0.000E+0
16	4.423E-3	7.548E-3	2.247E-2	9.307E-3	3.232E-3	5.725E-3	3.427E-3	4.521E-2	1.016E-1	0.000E+0
17	3.903E-3	6.661E-3	1.983E-2	8.213E-3	2.852E-3	5.052E-3	3.024E-3	4.189E-2	8.967E-2	0.000E+0
18	3.444E-3	5.877E-3	1.750E-2	7.247E-3	2.516E-3	4.458E-3	2.668E-3	3.882E-2	7.912E-2	0.000E+0
19	3.039E-3	5.186E-3	1.544E-2	6.395E-3	2.220E-3	3.934E-3	2.354E-3	3.597E-2	6.982E-2	0.000E+0
20	2.681E-3	4.576E-3	1.362E-2	5.643E-3	1.959E-3	3.471E-3	2.077E-3	3.334E-2	6.161E-2	0.000E+0
21	2.366E-3	4.038E-3	1.202E-2	4.979E-3	1.729E-3	3.063E-3	1.833E-3	3.089E-2	5.436E-2	0.000E+0
22	2.088E-3	3.563E-3	1.061E-2	4.393E-3	1.526E-3	2.703E-3	1.618E-3	2.863E-2	4.797E-2	0.000E+0
23	1.842E-3	3.144E-3	9.360E-3	3.877E-3	1.346E-3	2.385E-3	1.427E-3	2.653E-2	4.233E-2	0.000E+0
24	1.625E-3	2.774E-3	8.259E-3	3.421E-3	1.188E-3	2.104E-3	1.259E-3	2.458E-2	3.735E-2	0.000E+0
25	1.434E-3	2.448E-3	7.288E-3	3.018E-3	1.048E-3	1.857E-3	1.111E-3	2.278E-2	3.296E-2	0.000E+0
26	1.266E-3	2.160E-3	6.431E-3	2.663E-3	9.248E-4	1.638E-3	9.806E-4	2.111E-2	2.908E-2	0.000E+0
27	1.117E-3	1.906E-3	5.674E-3	2.350E-3	8.161E-4	1.446E-3	8.653E-4	1.956E-2	2.566E-2	0.000E+0
28	9.854E-4	1.682E-3	5.007E-3	2.074E-3	7.201E-4	1.276E-3	7.635E-4	1.813E-2	2.264E-2	0.000E+0
29	8.695E-4	1.484E-3	4.418E-3	1.830E-3	6.354E-4	1.126E-3	6.737E-4	1.680E-2	1.998E-2	0.000E+0
30	7.672E-4	1.309E-3	3.898E-3	1.615E-3	5.607E-4	9.932E-4	5.945E-4	1.557E-2	1.763E-2	0.000E+0
31	6.770E-4	1.155E-3	3.440E-3	1.425E-3	4.947E-4	8.764E-4	5.246E-4	1.443E-2	1.556E-2	0.000E+0
32	5.974E-4	1.020E-3	3.035E-3	1.257E-3	4.365E-4	7.733E-4	4.629E-4	1.337E-2	1.373E-2	0.000E+0
33	5.271E-4	8.997E-4	2.678E-3	1.109E-3	3.852E-4	6.824E-4	4.084E-4	1.239E-2	1.211E-2	0.000E+0
34	4.651E-4	7.938E-4	2.363E-3	9.789E-4	3.399E-4	6.021E-4	3.604E-4	1.148E-2	1.069E-2	0.000E+0
35	4.104E-4	7.005E-4	2.085E-3	8.637E-4	2.999E-4	5.313E-4	3.180E-4	1.064E-2	9.430E-3	0.000E+0
36	3.622E-4	6.181E-4	1.840E-3	7.622E-4	2.647E-4	4.688E-4	2.806E-4	9.857E-3	8.321E-3	0.000E+0
37	3.196E-4	5.454E-4	1.624E-3	6.725E-4	2.335E-4	4.137E-4	2.476E-4	9.135E-3	7.343E-3	0.000E+0
38	2.820E-4	4.813E-4	1.433E-3	5.934E-4	2.061E-4	3.650E-4	2.185E-4	8.465E-3	6.479E-3	0.000E+0
39	2.488E-4	4.247E-4	1.264E-3	5.236E-4	1.818E-4	3.221E-4	1.928E-4	7.844E-3	5.717E-3	0.000E+0
40	2.196E-4	3.747E-4	1.116E-3	4.620E-4	1.604E-4	2.842E-4	1.701E-4	7.269E-3	5.045E-3	0.000E+0

Appendices

41	1.937E-4	3.306E-4	9.844E-4	4.077E-4	1.416E-4	2.508E-4	1.501E-4	6.736E-3	4.451E-3	0.000E+0
42	1.709E-4	2.918E-4	8.686E-4	3.598E-4	1.249E-4	2.213E-4	1.325E-4	6.242E-3	3.928E-3	0.000E+0
43	1.508E-4	2.574E-4	7.664E-4	3.174E-4	1.102E-4	1.953E-4	1.169E-4	5.784E-3	3.466E-3	0.000E+0
44	1.331E-4	2.272E-4	6.763E-4	2.801E-4	9.727E-5	1.723E-4	1.031E-4	5.360E-3	3.058E-3	0.000E+0
45	1.174E-4	2.004E-4	5.968E-4	2.472E-4	8.583E-5	1.520E-4	9.100E-5	4.967E-3	2.699E-3	0.000E+0
46	1.036E-4	1.769E-4	5.266E-4	2.181E-4	7.573E-5	1.342E-4	8.030E-5	4.603E-3	2.381E-3	0.000E+0
47	9.145E-5	1.561E-4	4.646E-4	1.924E-4	6.682E-5	1.184E-4	7.085E-5	4.265E-3	2.101E-3	0.000E+0
48	8.069E-5	1.377E-4	4.100E-4	1.698E-4	5.897E-5	1.045E-4	6.252E-5	3.953E-3	1.854E-3	0.000E+0
49	7.120E-5	1.215E-4	3.618E-4	1.498E-4	5.203E-5	9.217E-5	5.517E-5	3.663E-3	1.636E-3	0.000E+0
50	6.283E-5	1.072E-4	3.192E-4	1.322E-4	4.591E-5	8.133E-5	4.868E-5	3.394E-3	1.444E-3	0.000E+0

4.3 Scenario 3: Belowground carbon inputs only

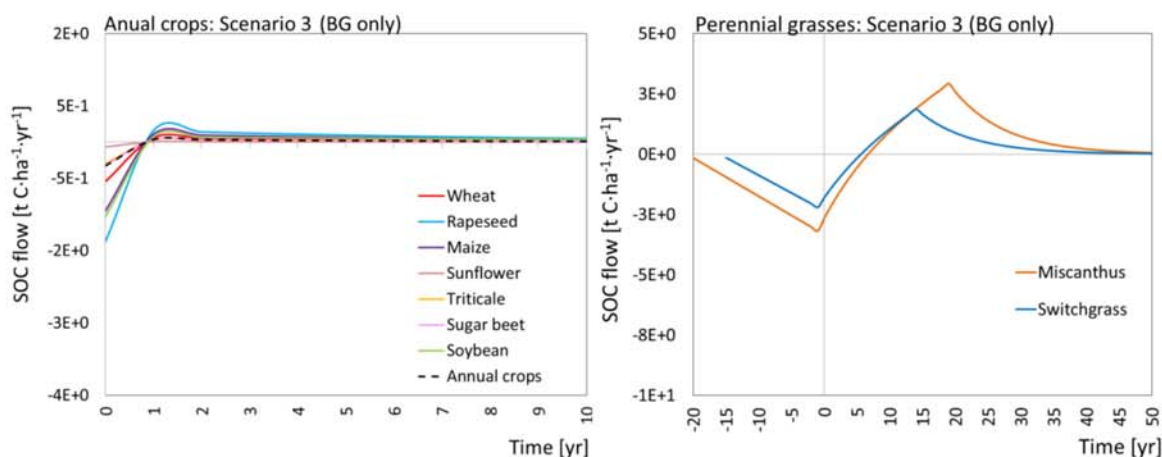

Fig. 6. Scenario 3 annual soil organic carbon elementary flows of annual crops and perennial grasses

Table14. Scenario 3 SOC flows [t C·ha⁻¹·yr⁻¹]

yr	Annual Crops							Perennial grasses		
	Total Annual	Wheat	Rape-seed	Maize	Sun-flower	Triticale	Sugar-beet	Soy-bean	Miscan-thus	Switch-grass
-20	0.000E+0	0.000E+0	0.000E+0	0.000E+0	0.000E+0	0.000E+0	0.000E+0	0.000E+0	-1.588E-1	0.000E+0
-19	0.000E+0	0.000E+0	0.000E+0	0.000E+0	0.000E+0	0.000E+0	0.000E+0	0.000E+0	-3.177E-1	0.000E+0
-18	0.000E+0	0.000E+0	0.000E+0	0.000E+0	0.000E+0	0.000E+0	0.000E+0	0.000E+0	-4.765E-1	0.000E+0
-17	0.000E+0	0.000E+0	0.000E+0	0.000E+0	0.000E+0	0.000E+0	0.000E+0	0.000E+0	-6.353E-1	0.000E+0
-16	0.000E+0	0.000E+0	0.000E+0	0.000E+0	0.000E+0	0.000E+0	0.000E+0	0.000E+0	-7.942E-1	0.000E+0
-15	0.000E+0	0.000E+0	0.000E+0	0.000E+0	0.000E+0	0.000E+0	0.000E+0	0.000E+0	-9.530E-1	-1.465E-1
-14	0.000E+0	0.000E+0	0.000E+0	0.000E+0	0.000E+0	0.000E+0	0.000E+0	0.000E+0	-1.112E+0	-2.930E-1
-13	0.000E+0	0.000E+0	0.000E+0	0.000E+0	0.000E+0	0.000E+0	0.000E+0	0.000E+0	-1.271E+0	-4.396E-1
-12	0.000E+0	0.000E+0	0.000E+0	0.000E+0	0.000E+0	0.000E+0	0.000E+0	0.000E+0	-1.429E+0	-5.861E-1
-11	0.000E+0	0.000E+0	0.000E+0	0.000E+0	0.000E+0	0.000E+0	0.000E+0	0.000E+0	-1.588E+0	-7.326E-1
-10	0.000E+0	0.000E+0	0.000E+0	0.000E+0	0.000E+0	0.000E+0	0.000E+0	0.000E+0	-1.747E+0	-8.791E-1
-9	0.000E+0	0.000E+0	0.000E+0	0.000E+0	0.000E+0	0.000E+0	0.000E+0	0.000E+0	-1.906E+0	-1.026E+0
-8	0.000E+0	0.000E+0	0.000E+0	0.000E+0	0.000E+0	0.000E+0	0.000E+0	0.000E+0	-2.065E+0	-1.172E+0
-7	0.000E+0	0.000E+0	0.000E+0	0.000E+0	0.000E+0	0.000E+0	0.000E+0	0.000E+0	-2.224E+0	-1.319E+0
-6	0.000E+0	0.000E+0	0.000E+0	0.000E+0	0.000E+0	0.000E+0	0.000E+0	0.000E+0	-2.382E+0	-1.465E+0
-5	0.000E+0	0.000E+0	0.000E+0	0.000E+0	0.000E+0	0.000E+0	0.000E+0	0.000E+0	-2.541E+0	-1.612E+0
-4	0.000E+0	0.000E+0	0.000E+0	0.000E+0	0.000E+0	0.000E+0	0.000E+0	0.000E+0	-2.700E+0	-1.758E+0
-3	0.000E+0	0.000E+0	0.000E+0	0.000E+0	0.000E+0	0.000E+0	0.000E+0	0.000E+0	-2.859E+0	-1.905E+0
-2	0.000E+0	0.000E+0	0.000E+0	0.000E+0	0.000E+0	0.000E+0	0.000E+0	0.000E+0	-3.018E+0	-2.051E+0
-1	0.000E+0	0.000E+0	0.000E+0	0.000E+0	0.000E+0	0.000E+0	0.000E+0	0.000E+0	-3.177E+0	-2.198E+0
0	-3.255E-1	-5.433E-1	-1.374E+0	-9.488E-1	-6.600E-2	-2.941E-1	-3.172E-1	-1.023E+0	-2.644E+0	-1.793E+0
1	3.828E-2	6.390E-2	1.616E-1	1.116E-1	7.762E-3	3.459E-2	3.731E-2	7.504E-2	-2.156E+0	-1.418E+0
2	3.378E-2	5.638E-2	1.426E-1	9.846E-2	6.849E-3	3.052E-2	3.292E-2	6.954E-2	-1.706E+0	-1.070E+0

3	2.980E-2	4.975E-2	1.258E-1	8.688E-2	6.044E-3	2.693E-2	2.905E-2	6.444E-2	-1.290E+0	-7.463E-1
4	2.630E-2	4.390E-2	1.110E-1	7.666E-2	5.333E-3	2.377E-2	2.563E-2	5.971E-2	-9.051E-1	-4.431E-1
5	2.320E-2	3.874E-2	9.796E-2	6.765E-2	4.706E-3	2.097E-2	2.262E-2	5.534E-2	-5.465E-1	-1.583E-1
6	2.048E-2	3.418E-2	8.644E-2	5.969E-2	4.152E-3	1.851E-2	1.996E-2	5.128E-2	-2.113E-1	1.102E-1
7	1.807E-2	3.016E-2	7.627E-2	5.267E-2	3.664E-3	1.633E-2	1.761E-2	4.752E-2	1.032E-1	3.644E-1
8	1.594E-2	2.661E-2	6.730E-2	4.648E-2	3.233E-3	1.441E-2	1.554E-2	4.403E-2	3.993E-1	6.059E-1
9	1.407E-2	2.348E-2	5.939E-2	4.101E-2	2.853E-3	1.271E-2	1.371E-2	4.081E-2	6.793E-1	8.363E-1
10	1.241E-2	2.072E-2	5.240E-2	3.619E-2	2.517E-3	1.122E-2	1.210E-2	3.781E-2	9.450E-1	1.057E+0
11	1.095E-2	1.828E-2	4.624E-2	3.193E-2	2.221E-3	9.899E-3	1.068E-2	3.504E-2	1.198E+0	1.269E+0
12	9.665E-3	1.613E-2	4.080E-2	2.818E-2	1.960E-3	8.735E-3	9.421E-3	3.247E-2	1.440E+0	1.473E+0
13	8.528E-3	1.424E-2	3.600E-2	2.486E-2	1.729E-3	7.708E-3	8.313E-3	3.009E-2	1.673E+0	1.670E+0
14	7.525E-3	1.256E-2	3.177E-2	2.194E-2	1.526E-3	6.801E-3	7.335E-3	2.788E-2	1.896E+0	1.861E+0
15	6.640E-3	1.108E-2	2.803E-2	1.936E-2	1.347E-3	6.001E-3	6.473E-3	2.584E-2	2.112E+0	1.642E+0
16	5.859E-3	9.781E-3	2.473E-2	1.708E-2	1.188E-3	5.295E-3	5.711E-3	2.394E-2	2.322E+0	1.449E+0
17	5.170E-3	8.631E-3	2.183E-2	1.507E-2	1.048E-3	4.673E-3	5.040E-3	2.219E-2	2.525E+0	1.279E+0
18	4.562E-3	7.616E-3	1.926E-2	1.330E-2	9.252E-4	4.123E-3	4.447E-3	2.056E-2	2.723E+0	1.128E+0
19	4.026E-3	6.720E-3	1.699E-2	1.174E-2	8.164E-4	3.638E-3	3.924E-3	1.905E-2	2.917E+0	9.957E-1
20	3.552E-3	5.930E-3	1.500E-2	1.036E-2	7.203E-4	3.210E-3	3.462E-3	1.766E-2	2.573E+0	8.786E-1
21	3.134E-3	5.232E-3	1.323E-2	9.137E-3	6.356E-4	2.833E-3	3.055E-3	1.636E-2	2.271E+0	7.753E-1
22	2.766E-3	4.617E-3	1.168E-2	8.063E-3	5.609E-4	2.500E-3	2.696E-3	1.516E-2	2.004E+0	6.841E-1
23	2.440E-3	4.074E-3	1.030E-2	7.115E-3	4.949E-4	2.206E-3	2.379E-3	1.405E-2	1.768E+0	6.036E-1
24	2.153E-3	3.595E-3	9.091E-3	6.278E-3	4.367E-4	1.946E-3	2.099E-3	1.302E-2	1.560E+0	5.326E-1
25	1.900E-3	3.172E-3	8.021E-3	5.539E-3	3.853E-4	1.717E-3	1.852E-3	1.207E-2	1.377E+0	4.700E-1
26	1.677E-3	2.799E-3	7.078E-3	4.888E-3	3.400E-4	1.515E-3	1.634E-3	1.118E-2	1.215E+0	4.147E-1
27	1.479E-3	2.470E-3	6.246E-3	4.313E-3	3.000E-4	1.337E-3	1.442E-3	1.036E-2	1.072E+0	3.659E-1
28	1.305E-3	2.179E-3	5.511E-3	3.806E-3	2.647E-4	1.180E-3	1.273E-3	9.602E-3	9.458E-1	3.229E-1
29	1.152E-3	1.923E-3	4.863E-3	3.358E-3	2.336E-4	1.041E-3	1.123E-3	8.898E-3	8.346E-1	2.849E-1
30	1.016E-3	1.697E-3	4.291E-3	2.963E-3	2.061E-4	9.186E-4	9.908E-4	8.245E-3	7.364E-1	2.514E-1
31	8.969E-4	1.497E-3	3.786E-3	2.615E-3	1.819E-4	8.106E-4	8.743E-4	7.641E-3	6.498E-1	2.218E-1
32	7.914E-4	1.321E-3	3.341E-3	2.307E-3	1.605E-4	7.153E-4	7.715E-4	7.080E-3	5.734E-1	1.958E-1
33	6.983E-4	1.166E-3	2.948E-3	2.036E-3	1.416E-4	6.311E-4	6.807E-4	6.561E-3	5.060E-1	1.727E-1
34	6.162E-4	1.029E-3	2.601E-3	1.796E-3	1.250E-4	5.569E-4	6.007E-4	6.080E-3	4.464E-1	1.524E-1
35	5.437E-4	9.077E-4	2.295E-3	1.585E-3	1.103E-4	4.914E-4	5.300E-4	5.634E-3	3.939E-1	1.345E-1
36	4.798E-4	8.009E-4	2.025E-3	1.399E-3	9.730E-5	4.336E-4	4.677E-4	5.221E-3	3.476E-1	1.187E-1
37	4.234E-4	7.067E-4	1.787E-3	1.234E-3	8.585E-5	3.826E-4	4.127E-4	4.838E-3	3.067E-1	1.047E-1
38	3.736E-4	6.236E-4	1.577E-3	1.089E-3	7.576E-5	3.376E-4	3.641E-4	4.484E-3	2.707E-1	9.240E-2
39	3.296E-4	5.503E-4	1.392E-3	9.610E-4	6.685E-5	2.979E-4	3.213E-4	4.155E-3	2.388E-1	8.153E-2
40	2.909E-4	4.855E-4	1.228E-3	8.480E-4	5.899E-5	2.629E-4	2.835E-4	3.850E-3	2.107E-1	7.194E-2
41	2.567E-4	4.284E-4	1.083E-3	7.482E-4	5.205E-5	2.320E-4	2.502E-4	3.568E-3	1.859E-1	6.348E-2
42	2.265E-4	3.781E-4	9.560E-4	6.602E-4	4.593E-5	2.047E-4	2.208E-4	3.306E-3	1.641E-1	5.602E-2
43	1.998E-4	3.336E-4	8.436E-4	5.826E-4	4.053E-5	1.806E-4	1.948E-4	3.064E-3	1.448E-1	4.943E-2
44	1.763E-4	2.944E-4	7.444E-4	5.141E-4	3.576E-5	1.594E-4	1.719E-4	2.839E-3	1.278E-1	4.362E-2
45	1.556E-4	2.597E-4	6.568E-4	4.536E-4	3.155E-5	1.406E-4	1.517E-4	2.631E-3	1.127E-1	3.849E-2
46	1.373E-4	2.292E-4	5.796E-4	4.003E-4	2.784E-5	1.241E-4	1.338E-4	2.438E-3	9.947E-2	3.396E-2
47	1.211E-4	2.022E-4	5.114E-4	3.532E-4	2.457E-5	1.095E-4	1.181E-4	2.259E-3	8.777E-2	2.997E-2
48	1.069E-4	1.784E-4	4.513E-4	3.116E-4	2.168E-5	9.661E-5	1.042E-4	2.094E-3	7.745E-2	2.644E-2
49	9.433E-5	1.575E-4	3.982E-4	2.750E-4	1.913E-5	8.525E-5	9.195E-5	1.940E-3	6.834E-2	2.333E-2
50	8.323E-5	1.389E-4	3.514E-4	2.426E-4	1.688E-5	7.522E-5	8.113E-5	1.798E-3	6.030E-2	2.059E-2

4.4 Scenario 4: Exogenous carbon inputs only

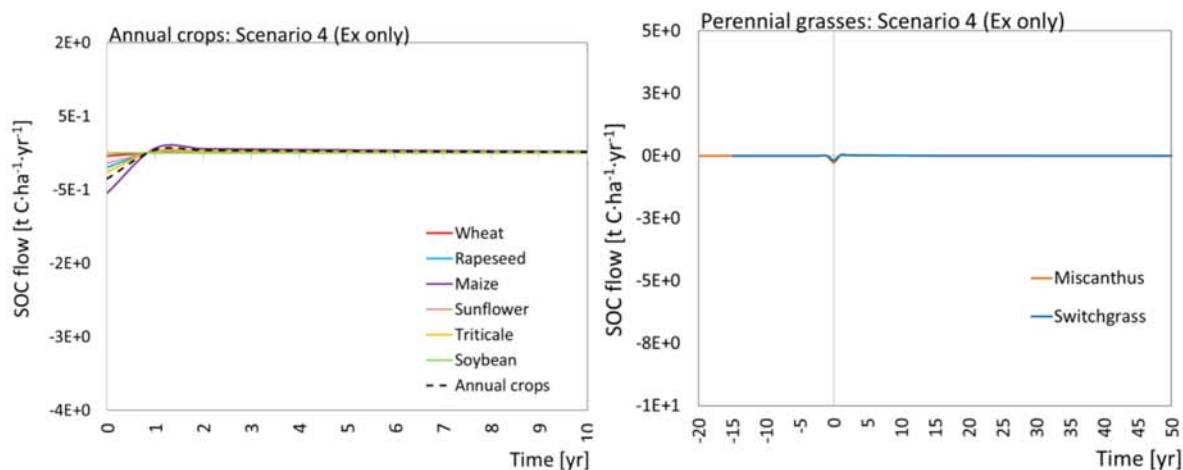

Fig. 7. Scenario 4 annual soil organic carbon elementary flows of annual crops and perennial grasses

Table15. Scenario 4 flows [t C·ha⁻¹·yr⁻¹]

yr	Annual Crops							Perennial grasses		
	Total Annual	Wheat	Rapeseed	Maize	Sunflower	Triticale	Sugar beet	Soybean	Miscanthus	Switchgrass
-20	-3.503E-1	-4.037E-2	-1.966E-1	-5.455E-1	-1.401E-1	-2.595E-1	-4.689E-1	0.000E+0	0.000E+0	0.000E+0
-19	1.399E-1	1.613E-2	7.854E-2	2.179E-1	5.597E-2	1.037E-1	1.874E-1	0.000E+0	0.000E+0	0.000E+0
-18	8.403E-2	9.686E-3	4.716E-2	1.309E-1	3.361E-2	6.225E-2	1.125E-1	0.000E+0	0.000E+0	0.000E+0
-17	5.046E-2	5.816E-3	2.832E-2	7.858E-2	2.018E-2	3.738E-2	6.756E-2	0.000E+0	0.000E+0	0.000E+0
-16	3.030E-2	3.493E-3	1.701E-2	4.719E-2	1.212E-2	2.244E-2	4.057E-2	0.000E+0	0.000E+0	0.000E+0
-15	1.819E-2	2.097E-3	1.021E-2	2.834E-2	7.277E-3	1.348E-2	2.436E-2	0.000E+0	0.000E+0	0.000E+0
-14	1.093E-2	1.259E-3	6.132E-3	1.701E-2	4.370E-3	8.093E-3	1.463E-2	0.000E+0	0.000E+0	0.000E+0
-13	6.561E-3	7.562E-4	3.682E-3	1.022E-2	2.624E-3	4.860E-3	8.783E-3	0.000E+0	0.000E+0	0.000E+0
-12	3.939E-3	4.541E-4	2.211E-3	6.135E-3	1.576E-3	2.918E-3	5.274E-3	0.000E+0	0.000E+0	0.000E+0
-11	2.366E-3	2.727E-4	1.328E-3	3.684E-3	9.461E-4	1.752E-3	3.167E-3	0.000E+0	0.000E+0	0.000E+0
-10	1.420E-3	1.637E-4	7.972E-4	2.212E-3	5.681E-4	1.052E-3	1.902E-3	0.000E+0	0.000E+0	0.000E+0
-9	8.530E-4	9.832E-5	4.787E-4	1.328E-3	3.412E-4	6.318E-4	1.142E-3	0.000E+0	0.000E+0	0.000E+0
-8	5.122E-4	5.904E-5	2.875E-4	7.977E-4	2.049E-4	3.794E-4	6.857E-4	0.000E+0	0.000E+0	0.000E+0
-7	3.076E-4	3.545E-5	1.726E-4	4.790E-4	1.230E-4	2.278E-4	4.118E-4	0.000E+0	0.000E+0	0.000E+0
-6	1.847E-4	2.129E-5	1.037E-4	2.876E-4	7.387E-5	1.368E-4	2.472E-4	0.000E+0	0.000E+0	0.000E+0
-5	1.109E-4	1.278E-5	6.224E-5	1.727E-4	4.436E-5	8.215E-5	1.485E-4	0.000E+0	0.000E+0	0.000E+0
-4	6.659E-5	7.676E-6	3.737E-5	1.037E-4	2.663E-5	4.933E-5	8.915E-5	0.000E+0	0.000E+0	0.000E+0
-3	3.999E-5	4.609E-6	2.244E-5	6.227E-5	1.599E-5	2.962E-5	5.353E-5	0.000E+0	0.000E+0	0.000E+0
-2	2.401E-5	2.768E-6	1.348E-5	3.739E-5	9.604E-6	1.779E-5	3.215E-5	0.000E+0	0.000E+0	0.000E+0
-1	1.442E-5	1.662E-6	8.092E-6	2.245E-5	5.767E-6	1.068E-5	1.930E-5	0.000E+0	0.000E+0	0.000E+0
0	-3.503E-1	-4.037E-2	-1.966E-1	-5.455E-1	-1.401E-1	-2.595E-1	-1.719E+0	0.000E+0	-2.720E-1	-1.776E-1
1	4.120E-2	4.748E-3	2.312E-2	6.416E-2	1.648E-2	3.052E-2	2.022E-1	0.000E+0	3.198E-2	2.089E-2
2	3.635E-2	4.190E-3	2.040E-2	5.661E-2	1.454E-2	2.693E-2	1.784E-1	0.000E+0	2.822E-2	1.844E-2
3	3.208E-2	3.697E-3	1.800E-2	4.995E-2	1.283E-2	2.376E-2	1.575E-1	0.000E+0	2.490E-2	1.627E-2
4	2.830E-2	3.262E-3	1.589E-2	4.408E-2	1.132E-2	2.097E-2	1.389E-1	0.000E+0	2.197E-2	1.435E-2
5	2.497E-2	2.879E-3	1.402E-2	3.889E-2	9.989E-3	1.850E-2	1.226E-1	0.000E+0	1.939E-2	1.267E-2
6	2.204E-2	2.540E-3	1.237E-2	3.432E-2	8.814E-3	1.632E-2	1.082E-1	0.000E+0	1.711E-2	1.118E-2
7	1.945E-2	2.241E-3	1.091E-2	3.028E-2	7.778E-3	1.440E-2	9.546E-2	0.000E+0	1.510E-2	9.862E-3
8	1.716E-2	1.978E-3	9.630E-3	2.672E-2	6.863E-3	1.271E-2	8.423E-2	0.000E+0	1.332E-2	8.702E-3
9	1.514E-2	1.745E-3	8.498E-3	2.358E-2	6.056E-3	1.122E-2	7.432E-2	0.000E+0	1.176E-2	7.679E-3
10	1.336E-2	1.540E-3	7.498E-3	2.081E-2	5.343E-3	9.896E-3	6.558E-2	0.000E+0	1.037E-2	6.776E-3

11	1.179E-2	1.359E-3	6.616E-3	1.836E-2	4.715E-3	8.732E-3	5.787E-2	0.000E+0	9.153E-3	5.979E-3
12	1.040E-2	1.199E-3	5.838E-3	1.620E-2	4.160E-3	7.705E-3	5.106E-2	0.000E+0	8.076E-3	5.276E-3
13	9.179E-3	1.058E-3	5.151E-3	1.429E-2	3.671E-3	6.799E-3	4.506E-2	0.000E+0	7.126E-3	4.655E-3
14	8.099E-3	9.336E-4	4.546E-3	1.261E-2	3.239E-3	5.999E-3	3.976E-2	0.000E+0	6.288E-3	4.108E-3
15	7.147E-3	8.238E-4	4.011E-3	1.113E-2	2.858E-3	5.294E-3	3.508E-2	0.000E+0	5.549E-3	3.625E-3
16	6.306E-3	7.269E-4	3.539E-3	9.821E-3	2.522E-3	4.671E-3	3.096E-2	0.000E+0	4.896E-3	3.198E-3
17	5.564E-3	6.414E-4	3.123E-3	8.666E-3	2.226E-3	4.122E-3	2.732E-2	0.000E+0	4.320E-3	2.822E-3
18	4.910E-3	5.660E-4	2.756E-3	7.647E-3	1.964E-3	3.637E-3	2.410E-2	0.000E+0	3.812E-3	2.490E-3
19	4.333E-3	4.994E-4	2.432E-3	6.747E-3	1.733E-3	3.209E-3	2.127E-2	0.000E+0	3.364E-3	2.197E-3
20	3.823E-3	4.407E-4	2.146E-3	5.954E-3	1.529E-3	2.832E-3	1.877E-2	0.000E+0	2.968E-3	1.939E-3
21	3.373E-3	3.888E-4	1.893E-3	5.254E-3	1.349E-3	2.499E-3	1.656E-2	0.000E+0	2.619E-3	1.711E-3
22	2.977E-3	3.431E-4	1.671E-3	4.636E-3	1.191E-3	2.205E-3	1.461E-2	0.000E+0	2.311E-3	1.510E-3
23	2.627E-3	3.028E-4	1.474E-3	4.091E-3	1.051E-3	1.946E-3	1.289E-2	0.000E+0	2.039E-3	1.332E-3
24	2.318E-3	2.671E-4	1.301E-3	3.609E-3	9.270E-4	1.717E-3	1.138E-2	0.000E+0	1.799E-3	1.175E-3
25	2.045E-3	2.357E-4	1.148E-3	3.185E-3	8.180E-4	1.515E-3	1.004E-2	0.000E+0	1.588E-3	1.037E-3
26	1.805E-3	2.080E-4	1.013E-3	2.810E-3	7.218E-4	1.337E-3	8.858E-3	0.000E+0	1.401E-3	9.152E-4
27	1.592E-3	1.835E-4	8.937E-4	2.480E-3	6.369E-4	1.179E-3	7.816E-3	0.000E+0	1.236E-3	8.076E-4
28	1.405E-3	1.620E-4	7.886E-4	2.188E-3	5.620E-4	1.041E-3	6.897E-3	0.000E+0	1.091E-3	7.126E-4
29	1.240E-3	1.429E-4	6.958E-4	1.931E-3	4.959E-4	9.184E-4	6.086E-3	0.000E+0	9.626E-4	6.288E-4
30	1.094E-3	1.261E-4	6.140E-4	1.704E-3	4.376E-4	8.103E-4	5.370E-3	0.000E+0	8.494E-4	5.548E-4
31	9.653E-4	1.113E-4	5.418E-4	1.503E-3	3.861E-4	7.150E-4	4.739E-3	0.000E+0	7.495E-4	4.896E-4
32	8.518E-4	9.818E-5	4.781E-4	1.327E-3	3.407E-4	6.309E-4	4.181E-3	0.000E+0	6.613E-4	4.320E-4
33	7.516E-4	8.663E-5	4.218E-4	1.171E-3	3.006E-4	5.567E-4	3.690E-3	0.000E+0	5.836E-4	3.812E-4
34	6.632E-4	7.645E-5	3.722E-4	1.033E-3	2.653E-4	4.913E-4	3.256E-3	0.000E+0	5.149E-4	3.364E-4
35	5.852E-4	6.745E-5	3.284E-4	9.114E-4	2.341E-4	4.335E-4	2.873E-3	0.000E+0	4.544E-4	2.968E-4
36	5.164E-4	5.952E-5	2.898E-4	8.042E-4	2.065E-4	3.825E-4	2.535E-3	0.000E+0	4.009E-4	2.619E-4
37	4.557E-4	5.252E-5	2.557E-4	7.096E-4	1.822E-4	3.375E-4	2.237E-3	0.000E+0	3.538E-4	2.311E-4
38	4.021E-4	4.634E-5	2.257E-4	6.262E-4	1.608E-4	2.978E-4	1.974E-3	0.000E+0	3.122E-4	2.039E-4
39	3.548E-4	4.089E-5	1.991E-4	5.525E-4	1.419E-4	2.628E-4	1.742E-3	0.000E+0	2.754E-4	1.799E-4
40	3.131E-4	3.608E-5	1.757E-4	4.875E-4	1.252E-4	2.319E-4	1.537E-3	0.000E+0	2.431E-4	1.588E-4
41	2.762E-4	3.184E-5	1.550E-4	4.302E-4	1.105E-4	2.046E-4	1.356E-3	0.000E+0	2.145E-4	1.401E-4
42	2.437E-4	2.810E-5	1.368E-4	3.796E-4	9.749E-5	1.806E-4	1.197E-3	0.000E+0	1.892E-4	1.236E-4
43	2.151E-4	2.479E-5	1.207E-4	3.350E-4	8.602E-5	1.593E-4	1.056E-3	0.000E+0	1.670E-4	1.091E-4
44	1.898E-4	2.188E-5	1.065E-4	2.956E-4	7.591E-5	1.406E-4	9.316E-4	0.000E+0	1.473E-4	9.625E-5
45	1.675E-4	1.930E-5	9.399E-5	2.608E-4	6.698E-5	1.240E-4	8.221E-4	0.000E+0	1.300E-4	8.493E-5
46	1.478E-4	1.703E-5	8.293E-5	2.301E-4	5.910E-5	1.095E-4	7.254E-4	0.000E+0	1.147E-4	7.494E-5
47	1.304E-4	1.503E-5	7.318E-5	2.031E-4	5.215E-5	9.658E-5	6.401E-4	0.000E+0	1.012E-4	6.613E-5
48	1.151E-4	1.326E-5	6.457E-5	1.792E-4	4.602E-5	8.522E-5	5.648E-4	0.000E+0	8.933E-5	5.835E-5
49	1.015E-4	1.170E-5	5.698E-5	1.581E-4	4.061E-5	7.520E-5	4.984E-4	0.000E+0	7.882E-5	5.149E-5
50	8.958E-5	1.033E-5	5.028E-5	1.395E-4	3.583E-5	6.636E-5	4.397E-4	0.000E+0	6.955E-5	4.543E-5

4.5 Comparison of all scenarios

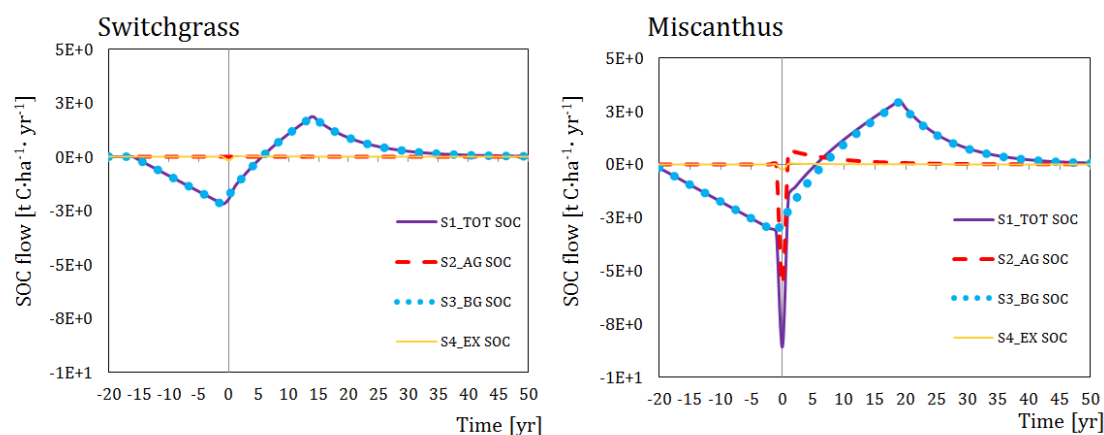

Fig. 8. SOC flows [t·C·ha⁻¹·yr⁻¹] per perennial energy crops and per management-driven variations

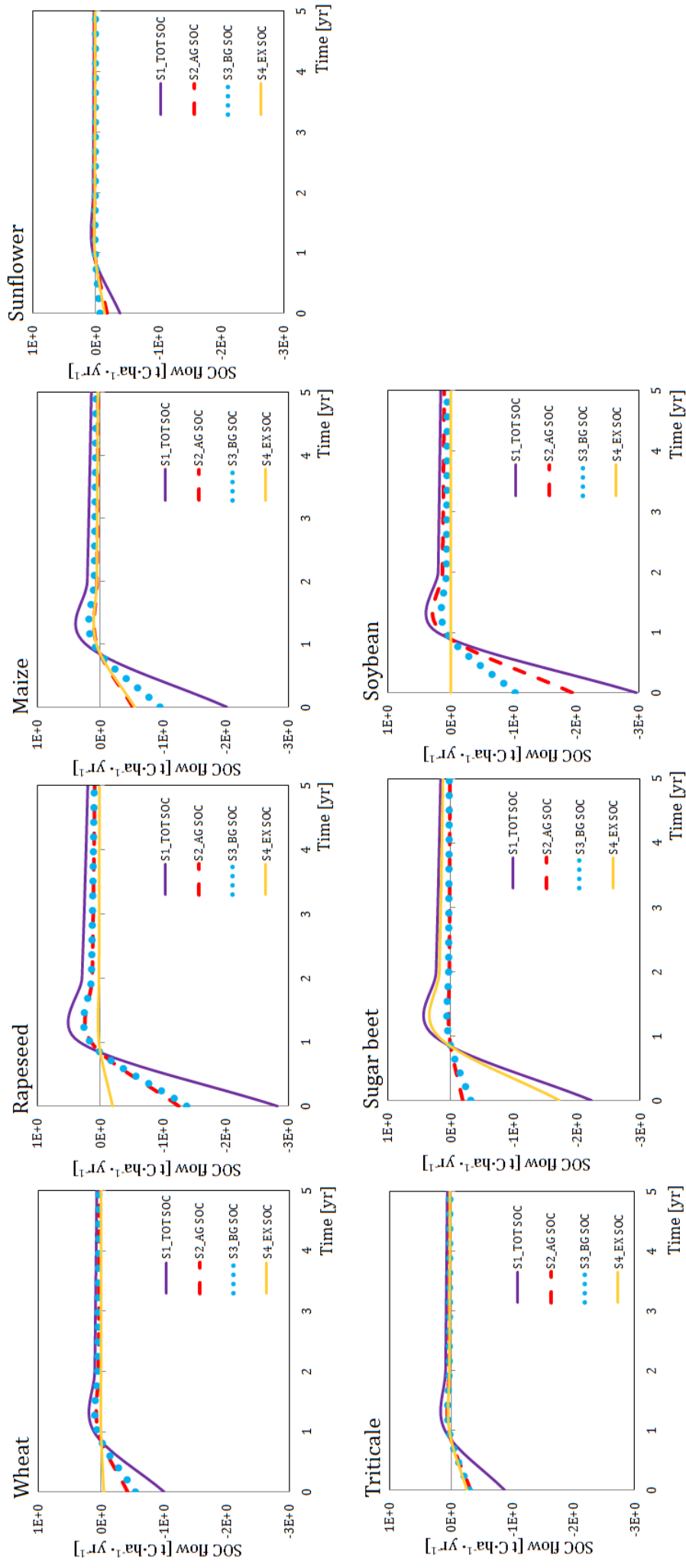

Fig. 9. SOC flows [t·C·ha⁻¹·yr⁻¹] per annual energy crops and per management-driven variations

5 Coupling results and sensitivity analysis

5.1 Cumulative radiative forcing results at year 2119

Fig. 11 shows the cumulative radiative forcing results at year 2119 for C-neutral and C-complete per SOC management-driven scenarios.

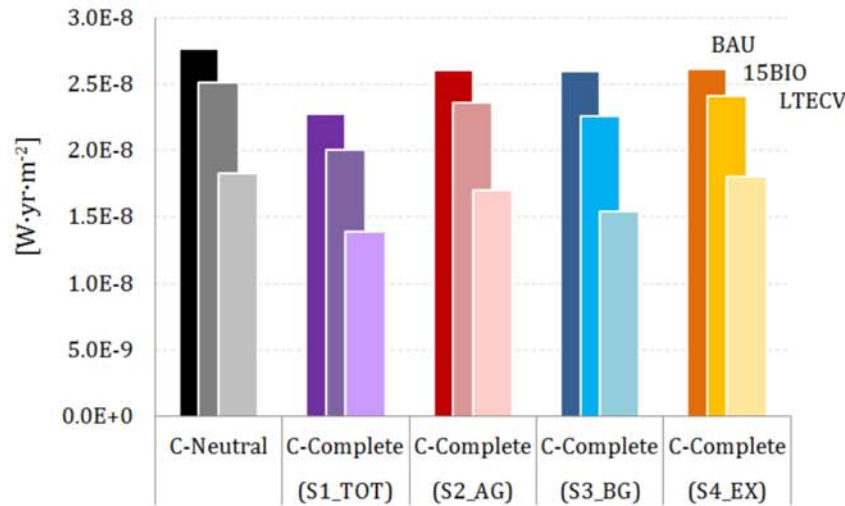

Fig.10. Cumulative radiative forcing [W·yr·m⁻²] over 100 years (2019-2119) per TIMES-MIRET scenario (BAU, 15BIO and LTECV) and management practices associated with soil organic carbon inputs

5.2 Sensitivity analysis on land occupation

The SOC_AG variations have significant consequences on the land occupation requirements, as plotted in Fig. 12.

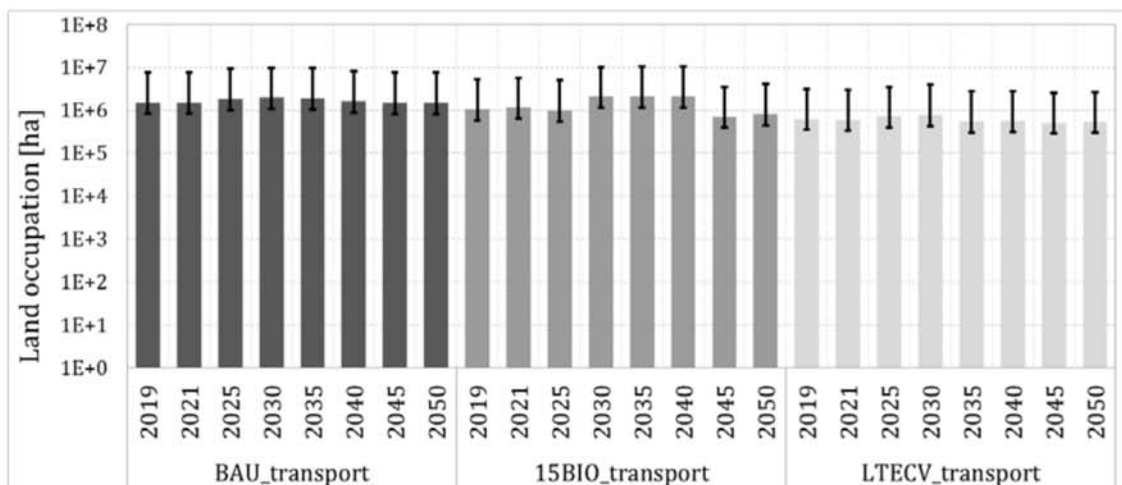

Fig. 11. Consequential variations of land occupation requirements [ha] linked with residue removal rates from the field for biofuel production, denoting increases by a factor of 5 with 90% removal and reductions by a factor of 0.56 with 10% removal rates as compared to original values

References for Appendix F

- ADEME, 2017a. Mobilisation de la Biomasse Agricole : état de l'art et analyse prospective. ADEME, Deloitte Développement Durable, Association d'Initiatives Locales pour l'Energie et l'Environnement (AILE), Alterra Wageningen. Angers. France.
- ADEME, 2017b. Agriculture et énergies renouvelables : état de l'art et opportunités pour les exploitations agricoles. ADEME, I Care & Consult, Blézat consulting, CERFrance, Céréopa.; Angers. France.
- Agostini, F., Gregory, A.S., Richter, G.M., 2015. Carbon Sequestration by Perennial Energy Crops : Is the Jury Still Out ? *Bioenergy Res.* 1057–1080. <https://doi.org/10.1007/s12155-014-9571-0>
- AGRESTE, 2019. Agreste - Données en ligne [WWW Document]. Ministère de l'Agriculture et de l'Alimentation. URL <https://stats.agriculture.gouv.fr/disar-web/disaron!/searchurl/searchUiid/search.disar> (accessed 2.1.19).
- AGRESTE, 2014. Pratiques culturales 2011 Principaux résultats: Principaux résultats - les Dossiers n°21, Ministère de l'Agriculture et de l'Alimentation. Ministère de l'Agriculture et de l'Alimentation- Agreste. Paris.
- Avadí, A., 2019. Screening LCA of French organic amendments and fertilisers. *Int. J. Life Cycle Assess.* [under Rev.].
- Besnard, A., Ferchaud, F., Levraut, F., Nguyen, E., Marsac, S., Savouré, M., 1, 2014. Le Lignoguide: Une aide aux choix des cultures biomasse. *Innov. Agron.* 34, 35–50.
- Bolinder, M A, Janzen, H.H., Gregorich, E.G., Angers, D.A., Vandenbygaart, A.J., 2007. An approach for estimating net primary productivity and annual carbon inputs to soil for common agricultural crops in Canada 118, 29–42. <https://doi.org/10.1016/j.agee.2006.05.013>
- Bolinder, M. A., Janzen, H.H., Gregorich, E.G., Angers, D.A., VandenBygaart, A.J., 2007. An approach for estimating net primary productivity and annual carbon inputs to soil for common agricultural crops in Canada. *Agric. Ecosyst. Environ.* 118, 29–42. <https://doi.org/10.1016/j.agee.2006.05.013>
- Carvalho, J.L., Hudiburg, T.W., Franco, H.C., DeLucia, E.H., 2017. Contribution of above- and belowground bioenergy crop residues to soil carbon. *GCB Bioenergy* 9, 1333–1343. <https://doi.org/10.1111/gcbb.12411>
- Cattelan, A.J., Dall'Agnol, A., 2018. The rapid soybean growth in Brazil. *Oilseeds fats Crop. Lipids* 25, D102. <https://doi.org/10.1051/ocl/2017058>
- Clivot, H., Mouny, J.-C., Duparque, A., Dinh, J.-L., Denoroy, P., Houot, S., Vertès, F., Trochard, R., Bouthier, A., Sagot, S., Mary, B., 2019. Modeling soil organic carbon evolution in long-term arable experiments with AMG model. *Environ. Model. Softw.* 118, 99–113. <https://doi.org/10.1016/j.envsoft.2019.04.004>
- Duparque, A., Boizard, H., Damay, N., Julien, J., Leclercq, C., Mary, B., 2007. Evolution de l'état organique du sol à l'échelle de la parcelle. *GEMAS-COMIFER Les 8èmes rencontres la Fertil. Raison. l'analyse terre* 1–16.

- Edwards, R., Lariv', J.-F., Richeard, D., Weinhof, W., 2014. Well-to-Tank Report" Version 4.a: JEC Well-To-Wheels Analysis of Future Automotive Fuels and Powertrains in the European Context, Report EUR 26237 EN. Ispra: JRC-Joint Research Centre. <https://doi.org/10.2790/95629>
- Ensinas, S.C., Serra, A.P., Marchetti, M.E., Da Silva, E.F., Do Prado, E.A.F., Lourente, E.R.P., Altomar, P.H., Potrich, D.C., Martinez, M.A., Do Amaral Conrad, V., Jesus, M.V., El Kadri, T.C., 2016. Cover crops affect on soil organic matter fractions under no till system. *Aust. J. Crop Sci.* 10, 503–512. <https://doi.org/10.21475/ajcs.2016.10.04.p7247x>
- Frisque, M., 2007. Gestion des matières organiques dans les sols cultivés en Région wallonne : avantages agronomiques, avantages environnementaux et séquestration du carbone Directeurs. Université Libre de Bruxelles IGEAT Institut de Gestion de l'Environnement et d'Aménagement du Territoire.
- Gis Sol, 2011. L'état des sols de France. Group. d'Intérêt Sci. sur les sols 1–188.
- Henin, S., Dupuis, M., 1945. Essai de bilan de la matière organique du sol. *Ann. Agron.* 1, 19–29.
- INRA-CIRAD-AFZ, 2017. Tables de composition et valeurs nutritionnelles des matières premières pour bovins, ovins, caprins, porcs, volailles, chevaux, lapins et salmonidés [WWW Document]. URL <https://feedtables.com/fr> (accessed 1.20.19).
- Irizar, A.B., Delaye, L.A.M., Andriulo, A.E., 2015. Projection of Soil Organic Carbon Reserves in the Argentine Rolling Pampa Under Different Agronomic Scenarios. Relationship of these Reserves with Some Soil Properties. *Open Agric. J.* 9, 30–41. <https://doi.org/10.2174/1874331501509010030>
- Joly, D., Brossard, T., Cardot, H., Cavailles, J., Hilal, M., Wavresky, P., 2010. Les types de climats en France, une construction spatiale - Types of climates on continental France, a spatial construction. *Cybergéo Eur. J. Geogr.* 1–23. <https://doi.org/10.4000/cybergeo.23155>
- Le Villio, M., Arrouays, D., Deslais, W., Daroussin, J., Le Bissonnais, Y., Clergeot, D., 2001. Estimation des quantités de matière organique exogène nécessaires pour restaurer et entretenir les sols limoneux français à un niveau organique donné. *Etude Gest. des Sols* 8, 47–64.
- Levasseur, A., Lesage, P., Margni, M., Deschênes, L., Samson, R., 2010. Considering time in LCA: Dynamic LCA and its application to global warming impact assessments. *Environ. Sci. Technol.* 44, 3169–3174. <https://doi.org/10.1021/es9030003>
- Moreno, R., Studdert, G.A., G, M.M., I, I.A., 2016. Soil organic carbon changes simulated with the AMG model in a high-organic-matter Mollisol. *Spanish J. Soil Sci.* 6, 212–229. <https://doi.org/10.3232/SJSS.2016.V6.N3.04>
- Myhre, G., Shindell, D., Bréon, F.-M., Collins, W., Fuglestedt, J., Huang, J., Koch, D., Lamarque, J.-F., Lee, D., Mendoza, B., Nakajima, T., Robock, A., Stephens, G., Takemura, T., Zhang, H., 2013. Chapter 8 Anthropogenic and Natural Radiative Forcing, in: Stocker, T.F., D. Qin, G.-K. Plattner, M. Tignor, S.K. Allen, J. Boschung, A. Nauels, Y. Xia, V.B. and P.M.M. (eds.). (Ed.), In: *Climate Change 2013: The Physical Science Basis. Contribution of Working Group I to the Fifth Assessment Report of the Intergovernmental Panel on Climate Change* [Stocker, T.F., D. Qin, G.-K. Plattner, M. Tignor, S.K.

- Allen, J. Boschung, A. Nauels, Y. Cambridge University Press, Cambridge, United Kingdom and New York, pp. 659–740. <https://doi.org/10.1017/CBO9781107415324.018>
- Nagy, R.C., Porder, S., Brando, P., Davidson, E.A., Figueira, A.M. e. S., Neill, C., Riskin, S., Trumbore, S., 2018. Soil Carbon Dynamics in Soybean Cropland and Forests in Mato Grosso, Brazil. *J. Geophys. Res. Biogeosciences* 123, 18–31. <https://doi.org/10.1002/2017JG004269>
- O’Connell, A., Kousoulidou, M., Lonza, L., Weindorf, W., 2019. Considerations on GHG emissions and energy balances of promising aviation biofuel pathways. *Renew. Sustain. Energy Rev.* 101, 504–515. <https://doi.org/10.1016/j.rser.2018.11.033>
- Piccolo, G.A., Andriulo, A.E., Mary, B., 2008. Changes in soil organic matter under different land management in Misiones province (Argentina). *Sci. Agric.* 65, 290–297. <https://doi.org/10.1590/S0103-90162008000300009>
- Saffih-Hdadi, K., Mary, B., 2008. Modeling consequences of straw residues export on soil organic carbon. *Soil Biol. Biochem.* 40, 594–607. <https://doi.org/10.1016/j.soilbio.2007.08.022>
- Strullu, L., 2011. Nitrogen fluxes in a perennial energetic crop, *Miscanthus x giganteus* : experimental study and modelling elements.
- Strullu, L., Beaudoin, N., de Cortázar Atauri, I.G., Mary, B., 2014. Simulation of Biomass and Nitrogen Dynamics in Perennial Organs and Shoots of *Miscanthus × Giganteus* Using the STICS Model. *Bioenergy Res.* 7, 1253–1269. <https://doi.org/10.1007/s12155-014-9462-4>
- UNIFA, 1998. Chapter 1: Le Sol, in: *La Fertilisation*. UNIFA - Union des Industries de la Fertilisation (UNIFA), Union des Industries de la Fertilisation., pp. 1–78.
- Wiesmeier, M., Hübner, R., Dechow, R., Maier, H., Spörlein, P., Geuß, U., Hangen, E., Reischl, A., Schilling, B., Lützow, M. Von, Kögel-knabner, I., 2014. Estimation of past and recent carbon input by crops into agricultural soils of southeast Germany. *Eur. J. Agron.* 61, 10–23. <https://doi.org/10.1016/j.eja.2014.08.001>
- Wiesmeier, M., Spörlein, P., Geuß, U., Hangen, E., Haug, S., Reischl, A., Schilling, B., von Lützow, M., Kögel-Knabner, I., 2012. Soil organic carbon stocks in southeast Germany (Bavaria) as affected by land use, soil type and sampling depth. *Glob. Chang. Biol.* 18, 2233–2245. <https://doi.org/10.1111/j.1365-2486.2012.02699.x>
- Zabed, H., Sahu, J.N., Suely, A., Boyce, A.N., Faruq, G., 2017. Bioethanol production from renewable sources: Current perspectives and technological progress. *Renew. Sustain. Energy Rev.* 71, 475–501. <https://doi.org/10.1016/j.rser.2016.12.076>

Appendix G: SM of Manuscript 5

This Appendix contains the **Supplementary Material of Manuscript 4 (5.3)**: Full lifetime dynamic biogenic carbon modelling of oil palm applied to biochemical surfactant

1 Biomass proportions

Table 1. Biomass values and its proportions per crop fraction

Crop fractions	Biomass [t ha ⁻¹]	Proportion [%]
Stem	38.8	29%
FFB	22.9	38%
CPO	6.8	19%
POME	15.8	17%
EFB	6.0	43%
MFF	1.8	11%
PKS	0.7	5%
FBB	11.6	15%
Shed FBB	1.4	1.8%
MIPB	0.4	0.4%
Roots	13	15%
Total	82	100%

2 Biogenic carbon fixation during biomass growth

Table 2. Oil palm growth and carbon fixation per crop fraction (tree organs)

Age H	DBH	Stem	FBB	Shed FBB	MIPB	FFB	Root	Total	
[yr] [m]	[cm]	[t C·ha ⁻¹]	[t C·ha ⁻¹]	[t C·ha ⁻¹]	[t C·ha ⁻¹]	[t C·ha ⁻¹]	[t C·ha ⁻¹]	[t C·ha ⁻¹]	
0	0.0000	0.0000	0.0000	0.0000	0.0000	0.0000	0.0000	0.0000	
1	0.1251	76.8829	0.1573	0.0000	0.0000	0.0000	5.1655	2.9676	8.2904
2	0.3636	76.1941	0.4866	0.0000	0.0000	0.0000	8.2392	3.1292	11.8550
3	0.6712	75.5114	0.9504	0.6015	0.0000	0.0195	11.3225	3.2995	16.1934
4	1.0289	74.8349	1.5337	1.7429	0.0000	0.0320	13.6622	3.4791	20.4498
5	1.4247	74.1644	2.2256	2.7981	0.0000	0.0448	15.0890	3.6684	23.8261
6	1.8499	73.4999	3.0167	3.7672	0.0000	0.0582	15.8464	3.8681	26.5566
7	2.2980	72.8414	3.8980	4.6501	0.0592	0.0720	16.2190	4.0787	28.9769
8	2.7636	72.1887	4.8612	5.4467	0.1736	0.0862	16.3954	4.3007	31.2638
9	3.2426	71.5419	5.8980	6.1572	0.2853	0.1009	16.4774	4.5347	33.4536
10	3.7313	70.9010	7.0004	6.7815	0.3944	0.1160	16.5152	4.7816	35.5891
11	4.2267	70.2657	8.1607	7.3197	0.5007	0.1316	16.5325	5.0418	37.6871
12	4.7264	69.6362	9.3715	7.7716	0.6044	0.1476	16.5405	5.3163	39.7518
13	5.2281	69.0122	10.6257	8.1373	0.7053	0.1641	16.5441	5.6056	41.7821
14	5.7301	68.3939	11.9163	8.4169	0.8036	0.1810	16.5458	5.9107	43.7743
15	6.2308	67.7811	13.2371	8.6103	0.8991	0.1984	16.5466	6.2324	45.7238
16	6.7288	67.1738	14.5817	8.7174	0.9920	0.2162	16.5469	6.5717	47.6259
17	7.2230	66.5720	15.9445	8.7384	1.0822	0.2344	16.5471	6.9294	49.4760
18	7.7125	65.9755	17.3201	8.6733	1.1697	0.2531	16.5472	7.3065	51.2698
19	8.1962	65.3844	18.7032	8.5219	1.2544	0.2723	16.5472	7.7042	53.0032
20	8.6736	64.7986	20.0893	8.2843	1.3365	0.2919	16.5472	8.1236	54.6727

21	9.1441	64.2180	21.4738	7.9606	1.4159	0.3119	16.5472	8.5657	56.2751
22	9.6071	63.6427	22.8527	7.5506	1.4927	0.3324	16.5472	9.0320	57.8076
23	10.0621	63.0724	24.2223	7.0545	1.5667	0.3533	16.5472	9.5236	59.2676
24	10.5090	62.5073	25.5792	6.4722	1.6380	0.3747	16.5472	10.0419	60.6532
25	10.9473	61.9473	26.9201	5.8037	1.7066	0.3965	16.5472	10.5885	61.9626

3 Biogenic carbon to the soil

Table 3. Soil organic carbon balance

Time	Leaflets	Rachis	Petiole	Stem (shred)	Roots	POME	EFB	MFF	MIPB
[yr]	[t C ha ⁻¹]	[t C ha ⁻¹]	[t C ha ⁻¹]	[t C ha ⁻¹]	[t C ha ⁻¹]	[t C ha ⁻¹]	[t C ha ⁻¹]	[t C ha ⁻¹]	[t C ha ⁻¹]
0	0.0000	0.0000	0.0000	0.0000	0.0000	0.0000	0.0000	0.0000	0.0000
1	0.0000	0.0000	0.0000	0.0000	0.0000	0.0000	0.0000	0.0000	0.0000
2	0.0000	0.0000	0.0000	0.0000	0.0000	0.0000	0.0000	0.0000	0.0000
3	-0.0419	-0.0436	-0.0606	0.0000	0.0000	0.0000	0.0000	0.0000	-0.0419
4	-0.1523	-0.1624	-0.2272	0.0000	0.0000	-4.4375	-1.6832	-1.1476	-0.1523
5	-0.3074	-0.3416	-0.4752	0.0000	0.0000	-8.1846	-3.1045	-2.1167	-0.3074
6	-0.4897	-0.5678	-0.7836	0.0000	0.0000	-11.2036	-4.2496	-2.8975	-0.4897
7	-0.6912	-0.8348	-1.1423	0.0000	0.0000	-13.5586	-5.1429	-3.5065	-0.6912
8	-0.9057	-1.1363	-1.5418	0.0000	0.0000	-15.3585	-5.8257	-3.9720	-0.9057
9	-1.1236	-1.4621	-1.9672	0.0000	0.0000	-16.7172	-6.3410	-4.3234	-1.1236
10	-1.3377	-1.8030	-2.4054	0.0000	0.0000	-17.7348	-6.7270	-4.5866	-1.3377
11	-1.5429	-2.1511	-2.8455	0.0000	0.0000	-18.4936	-7.0148	-4.7828	-1.5429
12	-1.7353	-2.4993	-3.2782	0.0000	0.0000	-19.0576	-7.2287	-4.9287	-1.7353
13	-1.9118	-2.8414	-3.6956	0.0000	0.0000	-19.4761	-7.3875	-5.0369	-1.9118
14	-2.0705	-3.1719	-4.0909	0.0000	0.0000	-19.7864	-7.5052	-5.1172	-2.0705
15	-2.2096	-3.4860	-4.4585	0.0000	0.0000	-20.0163	-7.5924	-5.1766	-2.2096
16	-2.3282	-3.7795	-4.7934	0.0000	0.0000	-20.1865	-7.6569	-5.2206	-2.3282
17	-2.4252	-4.0487	-5.0916	0.0000	0.0000	-20.3125	-7.7047	-5.2532	-2.4252
18	-2.5001	-4.2903	-5.3495	0.0000	0.0000	-20.4058	-7.7401	-5.2774	-2.5001
19	-2.5523	-4.5014	-5.5641	0.0000	0.0000	-20.4748	-7.7663	-5.2952	-2.5523
20	-2.5816	-4.6795	-5.7330	0.0000	0.0000	-20.5259	-7.7857	-5.3084	-2.5816
21	-2.5876	-4.8224	-5.8539	0.0000	0.0000	-20.5637	-7.8000	-5.3182	-2.5876
22	-2.5702	-4.9280	-5.9250	0.0000	0.0000	-20.5917	-7.8106	-5.3254	-2.5702
23	-2.5293	-4.9947	-5.9447	0.0000	0.0000	-20.6124	-7.8185	-5.3308	-2.5293
24	-2.4646	-5.0209	-5.9118	0.0000	0.0000	-20.6277	-7.8243	-5.3347	-2.4646
25	-2.4772	-5.0053	-5.9713	-8.0760	-3.1765	-20.6390	-7.8286	-5.3377	-2.4772
26	-1.8331	-4.4046	-5.0756	-7.1877	-2.9542	-15.2729	-5.7932	-3.9499	-1.8331
27	-1.3565	-3.8761	-4.3143	-6.3970	-2.7474	-11.3019	-4.2869	-2.9229	-1.3565
28	-1.0038	-3.4109	-3.6671	-5.6933	-2.5551	-8.3634	-3.1723	-2.1630	-1.0038
29	-0.7428	-3.0016	-3.1171	-5.0671	-2.3762	-6.1889	-2.3475	-1.6006	-0.7428
30	-0.5497	-2.6414	-2.6495	-4.5097	-2.2099	-4.5798	-1.7372	-1.1844	-0.5497
31	-0.4068	-2.3245	-2.2521	-4.0136	-2.0552	-3.3891	-1.2855	-0.8765	-0.4068
32	-0.3010	-2.0455	-1.9143	-3.5721	-1.9113	-2.5079	-0.9513	-0.6486	-0.3010
33	-0.2227	-1.8001	-1.6271	-3.1792	-1.7775	-1.8558	-0.7039	-0.4800	-0.2227
34	-0.1648	-1.5841	-1.3831	-2.8295	-1.6531	-1.3733	-0.5209	-0.3552	-0.1648
35	-0.1220	-1.3940	-1.1756	-2.5182	-1.5374	-1.0163	-0.3855	-0.2628	-0.1220
36	-0.0903	-1.2267	-0.9993	-2.2412	-1.4298	-0.7520	-0.2853	-0.1945	-0.0903
37	-0.0668	-1.0795	-0.8494	-1.9947	-1.3297	-0.5565	-0.2111	-0.1439	-0.0668
38	-0.0494	-0.9500	-0.7220	-1.7753	-1.2366	-0.4118	-0.1562	-0.1065	-0.0494
39	-0.0366	-0.8360	-0.6137	-1.5800	-1.1501	-0.3047	-0.1156	-0.0788	-0.0366

40	-0.0271	-0.7356	-0.5216	-1.4062	-1.0695	-0.2255	-0.0855	-0.0583	-0.0271
41	-0.0200	-0.6474	-0.4434	-1.2515	-0.9947	-0.1669	-0.0633	-0.0432	-0.0200
42	-0.0148	-0.5697	-0.3769	-1.1139	-0.9251	-0.1235	-0.0468	-0.0319	-0.0148
43	-0.0110	-0.5013	-0.3203	-0.9913	-0.8603	-0.0914	-0.0347	-0.0236	-0.0110
44	-0.0081	-0.4412	-0.2723	-0.8823	-0.8001	-0.0676	-0.0256	-0.0175	-0.0081
45	-0.0060	-0.3882	-0.2314	-0.7852	-0.7441	-0.0500	-0.0190	-0.0129	-0.0060
46	-0.0044	-0.3416	-0.1967	-0.6989	-0.6920	-0.0370	-0.0140	-0.0096	-0.0044
47	-0.0033	-0.3006	-0.1672	-0.6220	-0.6435	-0.0274	-0.0104	-0.0071	-0.0033
48	-0.0024	-0.2646	-0.1421	-0.5536	-0.5985	-0.0203	-0.0077	-0.0052	-0.0024
49	-0.0018	-0.2328	-0.1208	-0.4927	-0.5566	-0.0150	-0.0057	-0.0039	-0.0018
50	-0.0013	-0.2049	-0.1027	-0.4385	-0.5176	-0.0111	-0.0042	-0.0029	-0.0013
51	-0.0010	-0.1803	-0.0873	-0.3902	-0.4814	-0.0082	-0.0031	-0.0021	-0.0010
52	-0.0007	-0.1587	-0.0742	-0.3473	-0.4477	-0.0061	-0.0023	-0.0016	-0.0007
53	-0.0005	-0.1396	-0.0631	-0.3091	-0.4164	-0.0045	-0.0017	-0.0012	-0.0005
54	-0.0004	-0.1229	-0.0536	-0.2751	-0.3872	-0.0033	-0.0013	-0.0009	-0.0004
55	-0.0003	-0.1081	-0.0456	-0.2448	-0.3601	-0.0025	-0.0009	-0.0006	-0.0003
56	-0.0002	-0.0951	-0.0387	-0.2179	-0.3349	-0.0018	-0.0007	-0.0005	-0.0002
57	-0.0002	-0.0837	-0.0329	-0.1939	-0.3115	-0.0013	-0.0005	-0.0003	-0.0002
58	-0.0001	-0.0737	-0.0280	-0.1726	-0.2897	-0.0010	-0.0004	-0.0003	-0.0001
59	-0.0001	-0.0648	-0.0238	-0.1536	-0.2694	-0.0007	-0.0003	-0.0002	-0.0001
60	-0.0001	-0.0571	-0.0202	-0.1367	-0.2505	-0.0005	-0.0002	-0.0001	-0.0001
61	0.0000	-0.0502	-0.0172	-0.1217	-0.2330	-0.0004	-0.0002	-0.0001	0.0000
62	0.0000	-0.0442	-0.0146	-0.1083	-0.2167	-0.0003	-0.0001	-0.0001	0.0000
63	0.0000	-0.0389	-0.0124	-0.0964	-0.2015	-0.0002	-0.0001	-0.0001	0.0000
64	0.0000	-0.0342	-0.0106	-0.0858	-0.1874	-0.0002	-0.0001	0.0000	0.0000
65	0.0000	-0.0301	-0.0090	-0.0763	-0.1743	-0.0001	0.0000	0.0000	0.0000
66	0.0000	-0.0265	-0.0076	-0.0679	-0.1621	-0.0001	0.0000	0.0000	0.0000
67	0.0000	-0.0233	-0.0065	-0.0605	-0.1507	-0.0001	0.0000	0.0000	0.0000
68	0.0000	-0.0205	-0.0055	-0.0538	-0.1402	0.0000	0.0000	0.0000	0.0000
69	0.0000	-0.0181	-0.0047	-0.0479	-0.1304	0.0000	0.0000	0.0000	0.0000
70	0.0000	-0.0159	-0.0040	-0.0426	-0.1213	0.0000	0.0000	0.0000	0.0000
71	0.0000	-0.0140	-0.0034	-0.0379	-0.1128	0.0000	0.0000	0.0000	0.0000
72	0.0000	-0.0123	-0.0029	-0.0338	-0.1049	0.0000	0.0000	0.0000	0.0000
73	0.0000	-0.0108	-0.0024	-0.0301	-0.0975	0.0000	0.0000	0.0000	0.0000
74	0.0000	-0.0095	-0.0021	-0.0267	-0.0907	0.0000	0.0000	0.0000	0.0000
75	0.0000	-0.0084	-0.0018	-0.0238	-0.0844	0.0000	0.0000	0.0000	0.0000
76	0.0000	-0.0074	-0.0015	-0.0212	-0.0784	0.0000	0.0000	0.0000	0.0000
77	0.0000	-0.0065	-0.0013	-0.0189	-0.0730	0.0000	0.0000	0.0000	0.0000
78	0.0000	-0.0057	-0.0011	-0.0168	-0.0679	0.0000	0.0000	0.0000	0.0000
79	0.0000	-0.0050	-0.0009	-0.0149	-0.0631	0.0000	0.0000	0.0000	0.0000
80	0.0000	-0.0044	-0.0008	-0.0133	-0.0587	0.0000	0.0000	0.0000	0.0000
81	0.0000	-0.0039	-0.0007	-0.0118	-0.0546	0.0000	0.0000	0.0000	0.0000
82	0.0000	-0.0034	-0.0006	-0.0105	-0.0508	0.0000	0.0000	0.0000	0.0000
83	0.0000	-0.0030	-0.0005	-0.0094	-0.0472	0.0000	0.0000	0.0000	0.0000
84	0.0000	-0.0027	-0.0004	-0.0083	-0.0439	0.0000	0.0000	0.0000	0.0000
85	0.0000	-0.0023	-0.0003	-0.0074	-0.0408	0.0000	0.0000	0.0000	0.0000
86	0.0000	-0.0021	-0.0003	-0.0066	-0.0380	0.0000	0.0000	0.0000	0.0000
87	0.0000	-0.0018	-0.0003	-0.0059	-0.0353	0.0000	0.0000	0.0000	0.0000
88	0.0000	-0.0016	-0.0002	-0.0052	-0.0328	0.0000	0.0000	0.0000	0.0000
89	0.0000	-0.0014	-0.0002	-0.0047	-0.0305	0.0000	0.0000	0.0000	0.0000
90	0.0000	-0.0012	-0.0002	-0.0041	-0.0284	0.0000	0.0000	0.0000	0.0000
91	0.0000	-0.0011	-0.0001	-0.0037	-0.0264	0.0000	0.0000	0.0000	0.0000

92	0.0000	-0.0010	-0.0001	-0.0033	-0.0246	0.0000	0.0000	0.0000	0.0000
93	0.0000	-0.0008	-0.0001	-0.0029	-0.0228	0.0000	0.0000	0.0000	0.0000
94	0.0000	-0.0007	-0.0001	-0.0026	-0.0212	0.0000	0.0000	0.0000	0.0000
95	0.0000	-0.0007	-0.0001	-0.0023	-0.0198	0.0000	0.0000	0.0000	0.0000
96	0.0000	-0.0006	-0.0001	-0.0021	-0.0184	0.0000	0.0000	0.0000	0.0000
97	0.0000	-0.0005	0.0000	-0.0018	-0.0171	0.0000	0.0000	0.0000	0.0000
98	0.0000	-0.0004	0.0000	-0.0016	-0.0159	0.0000	0.0000	0.0000	0.0000
99	0.0000	-0.0004	0.0000	-0.0015	-0.0148	0.0000	0.0000	0.0000	0.0000
100	0.0000	-0.0003	0.0000	-0.0013	-0.0137	0.0000	0.0000	0.0000	0.0000

4 Dynamic full lifetime carbon accounting factors

Table 4. Dynamic full lifetime carbon accounting factors

Time	Biogenic carbon from CO ₂	Biogenic carbon from CH ₄	Time	Biogenic carbon from CO ₂	Biogenic carbon from CH ₄
[yr]	[t C-CO ₂ ·yr ⁻¹]	[t C-CH ₄ ·yr ⁻¹]	[yr]	[t C-CO ₂ ·yr ⁻¹]	[t C-CH ₄ ·yr ⁻¹]
-25	0.0000E+00	0.0000E+00	56	6.5085E-08	2.3667E-08
-24	-8.6158E-02	0.0000E+00	57	4.8163E-08	1.7514E-08
-23	-1.2320E-01	0.0000E+00	58	3.5641E-08	1.2960E-08
-22	-1.6829E-01	0.0000E+00	59	2.6374E-08	9.5906E-09
-21	-1.7788E-01	-2.0727E-04	60	1.9517E-08	7.0970E-09
-20	-2.0977E-01	-3.8230E-04	61	1.4442E-08	5.2518E-09
-19	-2.3659E-01	-5.2331E-04	62	1.0687E-08	3.8863E-09
-18	-2.6108E-01	-6.3331E-04	63	7.9087E-09	2.8759E-09
-17	-2.8462E-01	-7.1739E-04	64	5.8524E-09	2.1282E-09
-16	-3.0734E-01	-7.8085E-04	65	4.3308E-09	1.5748E-09
-15	-3.2957E-01	-8.2838E-04	66	3.2048E-09	1.1654E-09
-14	-3.5142E-01	-8.6382E-04	67	2.3715E-09	8.6238E-10
-13	-3.7291E-01	-8.9016E-04	68	1.7549E-09	6.3816E-10
-12	-3.9403E-01	-9.0970E-04	69	1.2987E-09	4.7224E-10
-11	-4.1472E-01	-9.2418E-04	70	9.6101E-10	3.4946E-10
-10	-4.3488E-01	-9.3488E-04	71	7.1114E-10	2.5860E-10
-9	-4.5441E-01	-9.4276E-04	72	5.2625E-10	1.9136E-10
-8	-4.7307E-01	-9.4849E-04	73	3.8942E-10	1.4161E-10
-7	-4.9049E-01	-9.5249E-04	74	2.8817E-10	1.0479E-10
-6	-5.0587E-01	-9.5496E-04	75	2.1325E-10	7.7545E-11
-5	-5.1780E-01	-9.5569E-04	76	1.5780E-10	5.7383E-11
-4	-5.2395E-01	-9.5388E-04	77	1.1677E-10	4.2463E-11
-3	-4.6270E-01	-9.4757E-04	78	8.6413E-11	3.1423E-11
-2	-4.4174E-01	-9.3276E-04	79	6.3946E-11	2.3253E-11
-1	-4.1555E-01	-9.0261E-04	80	4.7320E-11	1.7207E-11
0	-4.1626E-01	-7.0661E-04	81	3.5017E-11	1.2733E-11
1	2.1646E-01	-2.9132E-04	82	2.5912E-11	9.4227E-12
2	2.4325E-01	2.6117E-05	83	1.9175E-11	6.9728E-12
3	2.6785E-01	2.6599E-04	84	1.4190E-11	5.1599E-12
4	2.9145E-01	4.4585E-04	85	1.0500E-11	3.8183E-12
5	3.1423E-01	5.8004E-04	86	7.7702E-12	2.8255E-12
6	3.3648E-01	6.7985E-04	87	5.7500E-12	2.0909E-12
7	3.5832E-01	7.5393E-04	88	4.2550E-12	1.5473E-12
8	3.7978E-01	8.0886E-04	89	3.1487E-12	1.1450E-12

9	4.0082E-01	8.4955E-04	90	2.3300E-12	8.4728E-13
10	4.2143E-01	8.7968E-04	91	1.7242E-12	6.2699E-13
11	4.4154E-01	9.0197E-04	92	1.2759E-12	4.6397E-13
12	4.6109E-01	9.1845E-04	93	9.4418E-13	3.4334E-13
13	4.8000E-01	9.3059E-04	94	6.9869E-13	2.5407E-13
14	4.9814E-01	9.3945E-04	95	5.1703E-13	1.8801E-13
15	5.1528E-01	9.4575E-04	96	3.8261E-13	1.3913E-13
16	5.3097E-01	9.4984E-04	97	2.8313E-13	1.0296E-13
17	5.4428E-01	9.5162E-04	98	2.0951E-13	7.6187E-14
18	5.5329E-01	9.5026E-04	99	1.5504E-13	5.6378E-14
19	5.5413E-01	9.4360E-04	100	1.1473E-13	4.1720E-14
20	5.3962E-01	9.2718E-04	101	8.4900E-14	3.0873E-14
21	4.9891E-01	8.9339E-04	102	6.2826E-14	2.2846E-14
22	1.8180E-03	6.6111E-04	103	4.6491E-14	1.6906E-14
23	1.3453E-03	4.8922E-04	104	3.4404E-14	1.2510E-14
24	9.9556E-04	3.6202E-04	105	2.5459E-14	9.2577E-15
25	7.3671E-04	2.6790E-04	106	1.8839E-14	6.8507E-15
26	5.4517E-04	1.9824E-04	107	1.3941E-14	5.0695E-15
27	4.0342E-04	1.4670E-04	108	1.0316E-14	3.7514E-15
28	2.9853E-04	1.0856E-04	109	7.6342E-15	2.7761E-15
29	2.2092E-04	8.0333E-05	110	5.6493E-15	2.0543E-15
30	1.6348E-04	5.9446E-05	111	4.1805E-15	1.5202E-15
31	1.2097E-04	4.3990E-05	112	3.0936E-15	1.1249E-15
32	8.9520E-05	3.2553E-05	113	2.2892E-15	8.3245E-16
33	6.6245E-05	2.4089E-05	114	1.6940E-15	6.1601E-16
34	4.9021E-05	1.7826E-05	115	1.2536E-15	4.5585E-16
35	3.6276E-05	1.3191E-05	116	9.2765E-16	3.3733E-16
36	2.6844E-05	9.7615E-06	117	6.8646E-16	2.4962E-16
37	1.9865E-05	7.2235E-06	118	5.0798E-16	1.8472E-16
38	1.4700E-05	5.3454E-06	119	3.7591E-16	1.3669E-16
39	1.0878E-05	3.9556E-06	120	2.7817E-16	1.0115E-16
40	8.0496E-06	2.9271E-06	121	2.0585E-16	7.4853E-17
41	5.9567E-06	2.1661E-06	122	1.5233E-16	5.5391E-17
42	4.4080E-06	1.6029E-06	123	1.1272E-16	4.0990E-17
43	3.2619E-06	1.1861E-06	124	8.3414E-17	3.0332E-17
44	2.4138E-06	8.7775E-07	125	6.1726E-17	2.2446E-17
45	1.7862E-06	6.4953E-07			
46	1.3218E-06	4.8065E-07			
47	9.7813E-07	3.5568E-07			
48	7.2382E-07	2.6321E-07			
49	5.3562E-07	1.9477E-07			
50	3.9636E-07	1.4413E-07			
51	2.9331E-07	1.0666E-07			
52	2.1705E-07	7.8926E-08			
53	1.6062E-07	5.8406E-08			
54	1.1886E-07	4.3220E-08			
55	8.7953E-08	3.1983E-08			
