



**HAL**  
open science

# Multi-Airline Operations Optimization under major Disruptions

Marie Carré

► **To cite this version:**

Marie Carré. Multi-Airline Operations Optimization under major Disruptions. Operations Research [math.OA]. Université Clermont Auvergne, 2024. English. NNT : 2024UCFA0006 . tel-04547756

**HAL Id: tel-04547756**

**<https://theses.hal.science/tel-04547756>**

Submitted on 16 Apr 2024

**HAL** is a multi-disciplinary open access archive for the deposit and dissemination of scientific research documents, whether they are published or not. The documents may come from teaching and research institutions in France or abroad, or from public or private research centers.

L'archive ouverte pluridisciplinaire **HAL**, est destinée au dépôt et à la diffusion de documents scientifiques de niveau recherche, publiés ou non, émanant des établissements d'enseignement et de recherche français ou étrangers, des laboratoires publics ou privés.

UNIVERSITÉ - CLERMONT AUVERGNE  
*École Doctorale Sciences pour l'Ingénieur de Clermont Ferrand*

## **Thèse**

Présentée par :

**Marie Carré**

Pour l'obtention du grade de :

**Docteur d'université**

**Spécialité : Informatique**

---

# **Multi-Airline Operations Optimization under major Disruptions**

---

Soutenue publiquement le 16.01.2024

Devant le jury :

Pr. Daniel Delahaye	ENAC, OPTIM	Rapporteur
Dr Romain Guillaume	Université Toulouse-II-Jean-Jaurès, IRIT	Rapporteur
Dr Laurent Deroussi	IUT Clermont Auvergne, site de Montluçon, LIMOS	Examineur
Pr. Elise Vareilles	ISAE SUPAERO	Présidente du jury
Dr Séverine Durieux	Sigma Clermont, Institut Pascal	Directrice de thèse
Pr. Laurent Piétrac	Sigma Clermont, Institut Pascal	Co-directeur de thèse
M. Oliver Rueegg	Swiss International Air Lines	Invité
M. Eric Nantier	EU SES PRB member	Invité

Institut Pascal - Axe : Mécanique, Génie Mécanique, Génie Civil, Génie Industriel  
Université Clermont Auvergne / SIGMA Clermont



---

# Acknowledgments

---

Cette thèse n'aurait jamais vu le jour sans Séverine Durieux et Emmanuel Duc qui ont semé l'idée en venant à Zürich il y a de cela 6 ans... Idée qui a germé grâce la constance d'Éric.

Je tiens à chaleureusement remercier mes directeurs de thèse, Séverine Durieux et Laurent Piétrac, pour leur encadrement tout au long de ces quatre années, leur rigueur, leurs encouragements, leur intérêt dans mon sujet de thèse, ainsi que leur flexibilité pour apprendre tout un nouveau langage : celui du trafic aérien. Malgré la distance, cette thèse a été très riche humainement et scientifiquement, et m'a fait apprendre bien plus que ce que j'osais espérer.

Merci à mes rapporteurs, Daniel Delahaye et Romain Guillaume pour tout le temps investi dans la lecture de ce manuscrit et vos remarques constructives. Merci à Laurent Deroussi d'avoir accepté de faire partie de mon jury de thèse et à Elise Vareilles de l'avoir présidé. Je remercie l'ensemble de mon jury pour leur présence et nos discussions, qui ont mis en lumière de nouvelles perspectives de recherche.

Merci Éric d'avoir cru en moi, de m'avoir poussé à commencer cette thèse, et de m'avoir accompagné tout au long de ce travail. Merci pour ta confiance, ton aide, et tes précieux conseils quels que soient les sujets de discussion !

Ich möchte mich bei Oli und Sebastian bedanken, meinen beiden besten operativen Experten, die immer zur Stelle waren und Tag und Nacht geantwortet haben. Ein besonderer Dank geht auch an alle operativen Experten der Lufthansa Group Airlines, die mich unterstützt haben. Mit euch habe ich so viel gelernt!

Jeff, I will never be able to thank you enough for helping me all these years to make our GOM a true shinny gem. You even managed to make me discover the pleasure of coding by myself and as a team. Thank you very much for your support, your commitment, and your incredible motivation and dedication!

A big thank you to all my colleagues from SWISS and the Lufthansa Group who helped me with their technical skills, knowledge and time.

Un énorme merci à mes parents et ma famille. Non seulement ils m'ont encouragé et accompagné ces 30 dernières années, mais ils ont eu en plus la joie et la patience de me soutenir lors de ces quatre années de travail acharné. Merci à ma mère pour son écoute légendaire et sa présence à tout moment, à mon père pour ses conseils avisés et éternels (« Courage, Force, Robustesse, et tout le reste ») et à mes frères et sœurs, Etienne, Claire et Anaïs pour tous les rires, le soutien et les joyeux moments passés ensemble. C'est tellement chouette de voir comme nos liens se resserrent avec le temps, non seulement affectifs mais aussi géographiques !

À tous mes amis qui m'ont côtoyé et soutenu lors de ces 4 années de thèse : à ceux avec lesquels nos cours de piano et de solfège partagés nous ont donné une belle rigueur mais surtout une capacité de fous rires dans toutes les situations ; à ceux qui ont illuminés mes cours de collègue et lycée à coup bêtises et de beaux souvenirs; à mes sœurs folles de prépas et frères ingénieurs



qui le sont tout autant (spécialement Quentin qui a prouvé sa folie sans mesure en acceptant de relire cette thèse !); to all my friends who tried to teach me Plattdeutsch, Schwäbig, Schwizer Dutsch or Bayerisch, as well as all those who have been with me for almost 7 years in Zürich, in this beautiful multilingual adventure surrounded by mountains : Merci, danke, Merci Vielmal, Grazie, Gracias, φάλα, Faleminderit, धन्यवाद !

Enfin, celui à qui j'aimerais adresser mes remerciements les plus profonds, celui qui illumine ma vie tous les jours, et qui m'a supporté (dans tous les sens des termes anglais et français) tout au long de cette belle aventure : Frédéric, simplement merci d'être là, de m'accompagner sur le chemin de la vie. Promis, c'est fini, je ne travaillerai plus sur ma thèse les soirées et weekends, on peut raconter des bêtises et partir en montagne quand on en a envie !

PS : A tous : j'espère qu'on va vite pouvoir tester la PSO ensemble dans les Alpes, que ce soit en rando, ski ou alpi !

---

# Résumé

---

## **Optimisation des opérations multi-compagnie aérienne lors de perturbations majeurs**

Les perturbations dans l'espace aérien européen ont un impact significatif sur toutes les compagnies aériennes opérant dans les régions affectées. Cela entraîne un certain nombre d'annulations de vols et de retards. Lorsque plusieurs compagnies aériennes au sein d'un même groupe sont confrontées à ce même problème, notre hypothèse est la suivante : *nous supposons que l'optimisation conjointe de leurs ressources serait bénéfique à la fois pour le groupe de compagnies aériennes et pour leurs passagers.*

Cependant, parvenir à une optimisation conjointe soulève plusieurs défis. Tout d'abord, il est nécessaire de déterminer des contraintes judicieuses et de simplifier les variables et les données d'entrée pour répondre aux exigences de temps de calcul. Cela est crucial pour garantir qu'une méthode d'optimisation adéquate trouvera efficacement des solutions réalisables et optimales. De plus, une méthode de prise de décision multicritères doit être développée pour évaluer toutes les solutions tout en reflétant les opinions de plusieurs acteurs. Si plusieurs solutions sont trouvées à la fin de l'optimisation, un processus de consensus est primordial pour évaluer et sélectionner la solution de groupe la plus adaptée à mettre en œuvre.

De plus, il est nécessaire de développer un nouveau concept d'indicateur d'équité à long terme. Au lieu de limiter l'espace de recherche en ajoutant une contrainte forte d'équité entre les compagnies aériennes, l'équité doit être observée sur le long terme et des mécanismes de compensation doivent être définis pour aider le système à atteindre un équilibre en matière d'équité.

Nos travaux proposent une méthode d'optimisation semi-intégrée du problème du planning et des passagers pour le groupe Lufthansa. Chaque solution proposée est évaluée à travers un macro-indicateur défini par des experts de plusieurs compagnies aériennes. Les meilleures solutions générées font l'objet d'un processus de consensus, qui est influencé par des poids d'iniquité dérivés de l'indice d'équité à long terme.

En relevant ces défis et en développant notre approche dans un prototype, nous démontrons que les compagnies aériennes et leurs passagers peuvent bénéficier de solutions plus efficaces pour faire face aux perturbations de l'espace aérien européen.

**Mots clefs :** optimisation multicritères, multi-acteurs, équité, opérations aériennes.

---

# Summary

---

## **Multi-Airline Operations Optimization under major Disruptions**

Disruption in the European airspace has a significant impact on all airlines operating in the affected regions. It results in a given number of flight cancellations and delays. When multiple airlines within a same group are faced with this same problem, our hypothesis is the following: *we assume that jointly optimizing their resources could lead to find better solutions both for the airlines group and for their passengers.*

However, achieving a joint optimization rises several challenges. Firstly, it is required to determine judicious constraints and simplify the variables and entry data to meet the computational time requirements. This is crucial to ensure that an adequate optimization method will find efficiently feasible and optimal solutions. Additionally, a multi-criteria decision-making method must be developed evaluating all solutions while reflecting the opinions of several stakeholders. If several solutions are found at the end of the optimization time, a careful consensus process is essential to evaluate and select the most suitable group solution to be implemented.

Furthermore, a novel concept of a long-term global equity index needs to be developed. Instead of limiting the search space by adding a constraint about equity between the participating airlines, the equity must be monitored on the long-term and compensation mechanisms must be defined to help the system reach an equity balance.

In our work, we propose a semi-integrated optimization core for group schedule recovery and passengers' recovery. Each solution proposed is evaluated through a macro-indicator defined by multiple airlines' experts. The best solutions generated are then subject to a consensus identification process, which is influenced by inequity weights derived from the long-term global equity index.

By addressing these challenges and developing our approach in a prototype, we demonstrate that airlines and their passengers can benefit from more efficient solutions to face the disruptions of the European airspace.

**Key words:** multi-stakeholder, multicriteria optimization, equity, airline operations.

---

# Contents

---

<b>Part I. Introduction.....</b>	<b>1</b>
1. General Introduction and Industrial Context .....	1
1.1. General Context.....	1
1.2. Strategical Phase (Planning) .....	3
1.3. Tactical Phase (Steering).....	4
1.4. Operational Disruption .....	6
1.5. Need for Optimization .....	7
1.6. Airlines Group and Operational Coordination.....	7
1.6.1. Airlines group Strategies .....	7
1.6.2. Current Coordination Processes and On-going Projects.....	8
1.7. Chapter Conclusion .....	9
2. Literature Review on Airlines Operations Optimization.....	11
2.1. Aircraft Planning Recovery.....	12
2.2. Aircraft and Passengers Recovery .....	16
2.3. Crew and Aircraft & Crew Recovery .....	20
2.4. Integrated Recovery .....	24
2.5. Multi-Airlines Recovery .....	27
2.6. Chapter Conclusion .....	27
3. Problematic, Scientific Challenges and Methodology Structure.....	30
3.1. Conclusions from the Industrial Context and Literature Review .....	31
3.1.1. Summary on the Aircraft and Flight Recovery Problem.....	31
3.1.2. Summary on the Passenger and Crew Problems .....	31
3.1.3. Optimization Structure Proposition.....	33
3.1.4. Group Acceptance and Trust in a Multi-Airlines Approach.....	34
3.2. Thesis Research Questions and Methodology Structure .....	34
<b>Part II. Mathematical Formulation .....</b>	<b>37</b>
4. Mathematical Formulation of the Group Airlines Optimization.....	37
4.1. Input Data.....	39
4.1.1. Airport Data.....	39
4.1.2. Disruption Data.....	40
4.1.3. Aircraft Data .....	42
4.1.4. Considered Airlines Group Data.....	43
4.1.5. Passengers Data.....	44
4.1.6. Flights Data.....	45
4.1.7. Data of the Planned Flights at the Disrupted Airport .....	47
4.1.8. Passenger Reservations Data (within the Optimization	

	Timeframe).....	49
4.1.9.	Passenger Itineraries Data (within the Disruption Timeframe) ...	51
4.1.10.	Crews Data.....	52
4.1.11.	General Entry Parameters from the Users.....	54
4.2.	Decision Variables.....	54
4.2.1.	Decision Variables for the Planning Optimization .....	54
4.2.2.	Decision Variables for the Passengers Flow Optimization .....	54
4.3.	Associated Variables.....	55
4.4.	Constraints .....	58
4.4.1.	Constraints for the Planning Optimization.....	58
4.4.2.	Constraints for the Passenger Flow Optimization .....	61
4.5.	Indicators.....	63
4.5.1.	General .....	63
4.5.2.	P: Passengers Indicators.....	65
4.5.3.	C: Crew Indicators .....	68
4.5.4.	O: Operational Indicators .....	71
4.6.	Chapter Conclusion .....	72
<b>Part III. Multi-Stakeholders Decision Making and Long-Term Equity Method.....</b>		<b>75</b>
5.	Multi-Criteria Approach for a Group Decision Making .....	76
5.1.	Literature Review on Multi-Criteria Decision-Making.....	76
5.1.1.	MCDM Aggregative Methods .....	77
5.1.2.	MCDM Outranking Methods.....	83
5.1.3.	Conclusion .....	85
5.2.	Application of the AHP Method for the Airlines Group.....	86
5.2.1.	Hierarchical Criteria Tree Identification for the Industrial Use- Case 86	
5.2.2.	Multi-Stakeholder AHP Applied to the Industrial Use-Case.....	88
5.2.3.	Illustration on a Real Use-Case .....	90
5.3.	Chapter Conclusion .....	93
6.	Multi-Stakeholder Consensus Approach .....	95
6.1.	Literature Review on Multi-Stakeholders Consensus Identification.....	96
6.1.1.	Group MCDM and Group Compromise Methods .....	96
6.1.2.	Social Vote Theory .....	97
6.1.3.	Conclusion .....	99
6.2.	Application of the Borda Count Method for the Group Consensus .....	100
6.2.1.	Threshold of Indifference and Acceptable Interval of Performances .....	101
6.2.2.	Indifference threshold .....	101
6.2.3.	Acceptable interval of performances criterion per criterion.....	102
6.2.4.	Borda Score Ranking Method Applied to Local Rankings .....	102
6.2.5.	Consensus Identification Method for the Group of Stakeholders	

6.2.6.	Illustration on an Example and Discussion.....	105
6.3.	Chapter Conclusion .....	109
7.	Long-Term Equity Approach.....	111
7.1.	Literature Review on the Equity .....	112
7.1.1.	Equity Approaches .....	113
7.1.2.	Rules for Equity Measurements Indexes .....	114
7.1.3.	Gini Index.....	114
7.1.4.	Theil Index .....	115
7.1.5.	Atkinson Index.....	117
7.1.6.	Critical Analysis of the Literature Equity Indexes .....	118
7.1.7.	Conclusion .....	119
7.2.	Application of a Long-Term Global Equity Index.....	120
7.2.1.	Modelling the Airlines' Sensitivities .....	120
7.2.2.	Calculation for the Long-Term Global Equity Index .....	121
7.2.3.	Compensation Mechanisms .....	125
7.2.4.	Illustration on an Example .....	128
7.3.	Conclusion.....	129
<b>Part IV. Proposition of a Group Optimization Method.....</b>		<b>133</b>
8.	Optimization of the Flight Schedule .....	133
8.1.	Literature Review on Scheduling Optimization Methods.....	134
8.1.1.	Literature Review on Metaheuristics .....	134
8.1.2.	Particle Swarm Optimization Method .....	139
8.2.	Application of the PSO for the Airlines Group Scheduling Problem .....	147
8.2.1.	Adapted Discrete PSO Method .....	147
8.2.2.	Initialization Strategies.....	150
8.2.3.	Calibration .....	151
8.3.	Chapter Conclusion .....	154
9.	Passengers Optimization Approach.....	156
9.1.	Quick Passengers Optimization Method .....	157
9.1.1.	Method Developed .....	157
9.1.2.	Illustration on an Example .....	158
9.2.	Accurate Passengers Optimization Method .....	159
9.2.1.	Method Developed .....	159
9.2.2.	Illustration on an Example .....	164
9.3.	Comparison of the Methods .....	165
9.4.	Chapter Conclusion .....	166
<b>Part V. Application on an Industrial Case .....</b>		<b>169</b>
10.	Global Optimization Module: Concept Validation on an Industrial Use-Case .....	169
10.1.	Prototype Definition and Environment .....	170
10.2.	Use-Case and Data Collection .....	171
10.3.	Preliminary Configurations – AHP Questionnaire .....	174

10.4.	Task P1 – Define the Disruption.....	175
10.5.	Task P2 – Airlines Priorities.....	176
10.6.	Task P3 – Core Optimization.....	177
10.6.1.	Industrial Use-Case size.....	177
10.6.2.	Results.....	177
10.7.	Task P4 – Airline’s Ranking Decision-Support .....	180
10.8.	Task P5 – Group Consensus .....	183
10.1.	Task P6 –Long-Term Inequity Related Inequity Weights Update .....	183
10.2.	Conclusion.....	184
<b>Part VI. Conclusions and Perspectives .....</b>		<b>187</b>
11.	Conclusion .....	187
11.1.	Thesis Summary .....	187
11.2.	Thesis Contribution to the Research Questions .....	189
11.3.	Thesis Perspectives.....	191
<b>APPENDICES .....</b>		<b>194</b>
A.	Mathematical Notation Table.....	194
B.	AHP Criteria Tree .....	201
C.	Long-Term Inequity Concept Analysis .....	202
a.	Equity Threshold Identification .....	202
b.	Inequity Weight Influence on Group Rankings.....	205
c.	Calibration of the Boltzmann SoftMax Operator .....	207
D.	Particle Swarm Optimization Calibration .....	211
a.	Large Scale Calibration.....	211
b.	Calibration Extension.....	214
c.	Parameters Set for the PSO .....	215
E.	Publications List .....	218
F.	Résumé de la Thèse .....	219
	Chapitre 1 : Introduction Générale et Contexte Industriel .....	219
	Chapitre 2 : Revue de littérature sur les Problèmes d’Optimisation des Opérations Aériennes.....	222
	Chapitre 3 : Problématique, Verrous Scientifiques et Structure du Mémoire.....	223
	Chapitre 4 : Formalisation Mathématiques .....	225
	Chapitre 5 : Approche Multicritères pour une décision de groupe.....	225
	Chapitre 6 : Consensus Multi-Acteurs.....	227
	Chapitre 7 : Approche Équité Long Terme .....	229
	Chapitre 8 : Optimisation du planning de vols .....	231
	Chapitre 9 : Optimisation des Flux de Passagers .....	233
	Chapitre 10 : Application à un cas industriel : le Module d’Optimisation Globale.....	234
	Conclusion Générale .....	235
	Perspectives .....	237
G.	Bibliography .....	239

---

# List of Figures

---

Figure 1: High-level summary of the processes around a flight. ....	4
Figure 2: Example of the processes necessary to operate a flight from an airline. ....	6
Figure 3: Number of publications per recovery type per year (Hassan et al., 2021). ....	11
Figure 4: High-level PhD overview of resolution step. ....	30
Figure 5: Entity-Relation Model of the inputs data of the problem. ....	38
Figure 6: Operational Times Illustration. ....	47
Figure 7: Illustration of a delay on the first flight of a rotation and the minimum. ....	58
Figure 8: Illustration of Departure Constraints caused by the opening and closing time of the airports. ....	59
Figure 9: Criteria tree identified for the Lufthansa Group to evaluate group solution. ....	65
Figure 10: Business Process Model and Notation of the methodology proposed. ....	73
Figure 11: Simplified AHP Tree with matrices gathering the pairwise comparison. ....	80
Figure 12: Hierarchical Criteria Tree developed with Experts from five different airlines. ....	86
Figure 13: User Interface developed to get the users pairwise comparison. ....	88
Figure 14: Answers provided by the Expert 1 and 4 for the group vision (M1). ....	90
Figure 15: Answers provided by the Expert 2 and 3 for the group vision (M1). ....	90
Figure 16: Default values all other airlines for which no expert was available (M1). ....	90
Figure 17: Answers provided by the Expert 1 and 4 for the group vision (M3). ....	92
Figure 18: Answers provided by the Expert 2 and 3 for the group vision (M3). ....	92
Figure 19: Default values for all other airlines for which no expert was available (M3). ....	92
Figure 20: P4, P5 and P6 detailed Business Process Model and Notation chart to illustrate the consensus process. ....	96
Figure 21: Illustration of the indifference threshold for a criterion d. ....	101
Figure 22: Illustration of the acceptable interval of performance for a criterion d. ....	102
Figure 23: Illustration of a conflict where one solution belongs to the indifference area with two inequivalent solutions. ....	103
Figure 24: User interface providing the users needed inputs. ....	104
Figure 25: Illustration of the Lorenzo curve ....	115
Figure 26: Global equity index evolution (lower graph) on a slightly unfair scenario. ....	123
Figure 27: Different approaches for calculating the long-term equity index. ....	124
Figure 28: Illustration of the inequity weights influence on the group consensus. ....	125
Figure 29: Influence of the $\tau$ parameter from the Boltzmann SoftMax function on the global equity index influenced by the inequity weights (on 74 instances). ....	128
Figure 30: Long-term equity outcomes comparison with and without inequity weights. ....	129
Figure 31: Metaheuristics methods illustration, based on (Ezugwu et al., 2021). ....	134
Figure 32: Particle Swarm Optimization – illustration of the movement of a particle. ....	141
Figure 33: Different neighborhood topologies illustrated by (El Dor et al., 2015). ....	142
Figure 34: general pseudo-code of the Particle Swarm Optimization. ....	142
Figure 35: pseudo-code updating the velocities as from (Izakian et al., 2010). ....	145
Figure 36: Illustration of the ring topology with 6 neighbors per particles. ....	151
Figure 37: Evolution of <i>gbesti</i> found by each particle and its neighbors versus the theoretical optimum (brown line – GBT) ....	154
Figure 38: Particles positions performances evolution. ....	154
Figure 39: Business Process Model Notation for P3 with a two-stage passenger optimization. ....	



.....	156
Figure 40: Pseudo-Code assigning passengers to alternative itineraries. ....	157
Figure 41: Illustration of the flows split from/to the disrupted airport CDG.....	160
Figure 42: Graph "Out" Creation - first step: flows' nodes and cancellation arcs.....	160
Figure 43: Graph "Out" Creation - final step: flights nodes and connecting arcs. ....	161
Figure 44: Graph "In" - Illustration on a simple example.....	163
Figure 45: Illustration of delay calculation on a basic example.....	163
Figure 46: Total costs evolution for both quick and accurate passenger optimizations (without delay costs). ....	165
Figure 47: Total costs evolution for both quick and accurate passenger optimizations (with delays costs). ....	165
Figure 48: Business Process Model and Notation for P3 with integrated schedule and accurate passenger optimizations.....	167
Figure 49: Final Business Process Model and Notation for the Global Optimization Prototype.....	170
Figure 50: Global Optimization Current Architecture.....	171
Figure 51: Illustration of all the mandatory capacity reduction since 2022. ....	172
Figure 52: User Interface P0 - Administrative Tab .....	174
Figure 53: User Interface P1 - Define Disruption.....	176
Figure 54: User Interface P2 - Airlines Priorities. ....	177
Figure 55: Results of the GOM on 100 test-replications for the strike scenario.....	179
Figure 56: User Interface P4 - Airlines Ranking Decision-Support.....	181
Figure 57: User Interface P4 - Airlines Ranking Decision-Support, User Sensitivity Inputs.182	182
Figure 58: User Interface P4 - Airlines Ranking Decision-Support, Airline Ranking.....	182
Figure 59: User Interface P4 - Group Consensus. ....	183
Figure 60: Illustration of inequity weights influence on similar rankings.....	205
Figure 61: Illustration of inequity weights influence on different rankings.....	206
Figure 62: Illustration of inequity weights influence on contradictory rankings. ....	206
Figure 63: Illustration of the global equity index influenced by the inequity weights calculated with the $\tau$ values of the Boltzmann SoftMax function. ....	207
Figure 64: Sensitivity Analysis of the $\tau$ parameter of the Boltzmann SoftMax operator. ....	210
Figure 65: Distribution of the best performance found by the PSO according to initial $w$ . ..	212
Figure 66: Distribution of the best performance found by the PSO according to the initial $c1$ and $c2$ .....	213
Figure 67: Distribution of the best performance reached by the PSO according to the linear coefficient $aw$ .....	213
Figure 68: Distribution of the best performance reached by the PSO according to the number of particles. ....	213
Figure 69: Distribution of the best performance reached by the PSO according to the ring topology.....	213
Figure 70: Distribution of the first iteration at which the best performance has been reached by the PSO.....	213
Figure 71: Distribution of the best performances reached according to $ac$ value.....	215
Figure 72: Distribution of the best performances reached according to $aw$ value .....	215
Figure 73: Distribution of the best performances according to the topology.....	215
Figure 74 : Distribution of the first iteration at which the best performance has been reached for the first time, according to the topology.....	215
Figure 75: Distribution of the delta of performances reached by the swarm in comparison with the theoretical optimum solution with fixed $w$ , $c1$ , $c2$ .....	217
Figure 76: Distribution of the delta of performances reached by the swarm in comparison with the theoretical optimum solution with slightly decreasing $w$ , $c1$ , $c2$ . ....	217

---

# List of Tables

---

Table 1: Overview of the articles reviewed in the aircraft planning recovery. ....	15
Table 2: Overview of the literature review for the aircraft & passenger recovery problem. ..	19
Table 3: Overview of the literature review for the crew and the crew & aircraft recovery problem. ....	23
Table 4: Overview of the literature review for the integrated recovery.....	26
Table 5: Matrix illustrating the passenger categories as from the PaxType (indexed by pt) and PaxPrio (indexed by pp).....	45
Table 6: Saaty's scale (Saaty, 1987) showing the Intensity of importance on an absolute scale. .....	80
Table 7: Random Consistency Index according to the size of the matrix, proposed by Saaty in 1987 .....	89
Table 8: Group normalized matrix for the level M1.....	91
Table 9: Group normalized matrix for the level M3.....	91
Table 10: Table of solutions for airline A on which the Borda will apply.....	106
Table 11: Total Borda points attributed to each solution.....	106
Table 12: Ranking for airline A based on Borda points .....	106
Table 13 : Rankings for the three participating airlines .....	107
Table 14: Ranking of the group vision - all airlines' votes. ....	107
Table 15: Illustration of very different rankings.....	107
Table 16: Ranking of the group vision - all airlines' votes. ....	107
Table 17: Illustration of a very imbalanced situation.....	108
Table 18: Ranking of the group vision. ....	108
Table 19: Ranking of the group vision with weights influence.....	108
Table 20: Overview of the literature review for the PSO coefficient calibration.....	146
Table 21: Illustration of a particle. ....	147
Table 22: Illustration of the statuses on which a flight can be assigned.....	147
Table 23: Illustration of a velocity matrix for a particle.....	148
Table 24: Illustration of the curfew limits on a flight with a curfew 35 minutes after STD...	149
Table 25: Table of parameters and ranges to test during the PSO calibration.....	152
Table 26: Parameters tested within the refinement calibration. ....	153
Table 27: Example of arrays for solving the minimum cost flows problem. ....	165
Table 28: Example of the supply array.....	165
Table 29: Overview of the GOM results on 100 instances. ....	178
Table 30: Long-term inequity Theil index and its derived inequity weights calculation.....	184
Table 31: Summary of tested scenarios for the inequity threshold identification .....	202
Table 32: Proposed Theil index equity threshold according to misbalanced situation .....	205
Table 33: parameters tested within the refinement calibration. ....	214

---

# Glossary of Terms

---

ACO	Ant Colony Optimization
AGIFORS	Airline Group of the International Federation of Operational Research Societies
AHP	Analytic Hierarchy Process
ANP	Analytic Network Process
AOG	Aircraft On Ground
ATC	Air Traffic Control
ATM	Air Traffic Management
CODA	Central Office for Delay Analysis (EUROCONTROL Team)
EASA	European Union Aviation Safety Agency
ELECTRE	Elimination and Choice Expressing Reality
EUC	European Union Commission
EUROCONTROL	European Organization for the Safety of Air Navigation
GA	Genetic Algorithm
GBT	Global Best in Theory (in the PSO context)
GOM	Global Optimization Module
IATA	International Air Transport Association
ICAO	International Civil Aviation Organization
LH FRA	Lufthansa IATA Code, operating from Frankfurt airport
LTOT	Last Time of Touchdown

LX	SWISS IATA Code
MCDM	Multi-criteria Decision-Making
LH MUC	Lufthansa IATA Code, operating from Munich airport
NOC	Network Operations Controller
OCC	Operations Control Center
OPSD	Operations Decision Support Suite project at the Lufthansa Group
OR	Operations Research
OS	Austrian Airlines IATA Code
PROMETHEE	Preference Ranking Organization Method for Enrichment Evaluation
PSO	Particle Swarm Optimization
ROADEF	Société Française de Recherche Opérationnelle et d'Aide à la Décision
SESAR	Single European Sky ATM Research
SN	Brussels Airlines IATA Code
SPV	Smallest Position Value
STA	Scheduled Time of Arrival
STD	Scheduled Time of Departure
TOPSIS	Technique for Order of Preference by Similarity to Ideal Solution
UI	User Interface
UTC	Coordinated Universal Time
VIP	Very Important Person (passenger status)
ZRH	Zurich (airport)



# Introduction

---

## 1. General Introduction and Industrial Context

Airlines operations is a field full of complexity, specific and intricate rules, that attracted the operations research community already in the 1960's thanks to the Airline Group of the International Federation of Operational Research Societies (AGIFORS<sup>1</sup>) creation. With the technological and scientific advances, the research contribution from the operations research community grew, and the industries interest raises to implement the first tools into live operations. Several methods for single airlines operations were or are being implemented.

This thesis falls into the willingness of Swiss International Air Lines (SWISS) to seek for always more efficient, stable, customer-oriented, and sustainable operations. SWISS funded this thesis to explore a new research path: the optimization of multiple airlines. SWISS interest targets the collaboration benefits to reduce the operational impact on airlines during major disruptions, such as capacity reductions of an airport due to strikes or weather phenomena. SWISS being part of the Lufthansa Group, the industrial cases to test the methodology developed during this thesis applied to all airlines of the Lufthansa group.

### 1.1. General Context

European and worldwide mobility is expending, and so does air traffic. EUROCONTROL, the European Organization for the Safety of Air Navigation, reports a traffic growth despite the years of Covid-19 (EUROCONTROL, 2022a) and forecasts more than 13 million flights per year in the ECAC<sup>2</sup> area by 2030, and 16 million by 2050 (against 11 million in 2019). Since 2018, each year is a major challenge to manage the growing traffic, and the complexity is arising. The European Air Traffic Management (ATM) is at its limits, sometimes provoking

---

<sup>1</sup> <http://www.agifors.org>

<sup>2</sup> ECAC (European Civil Aviation Conference): see list of countries [here](#)

major disruption starting from a small one, through ripple effect in the saturated network. Airlines must cope with this passenger demand and traffic growth while the European ATM reaches its maximum capacity. A continuous optimization is necessary from the flight schedule choice until the flight itself to ensure as less delay and disruption as possible. Airlines operations centers deal with this high complexity and aims at offering the best operational efficiency and stability as possible and allowing the passengers to reach smoothly their destination.

Complexity does not only lie on the ATM situation. Within one airline, strategical choices result in most of them operating different aircraft types, categorized as short, medium, or long haul, depending on the range of miles that can be flown. The performance of each aircraft is different depending on the engines and additional features of the aircraft (such as sharklets). For example, some A32X aircraft (Airbus 319/320/321 family) can be equipped with transponders, specific communication, and radars tools, to be able to fly segment of transatlantic routes. An aircraft of an airline can therefore have different equipment than the same aircraft type of another airline. Thus, the crews are certified to fly only on their airline's aircraft and no flexibility between airlines is possible. Another example, the Bombardier CSeries (now called Airbus 22X) was certified only in March 2018 – more than 1 year and half after first operations – to fly low visibility procedures of category IIIa & IIIb approaches (auto land operations as precision instrument approaches with decision heights lower than 100 feet and runway visibility of less than 250 feet) (EASA, 2023). Crewmembers must thus be qualified on certain procedures, certain approaches (a famous one being London City<sup>3</sup>), which results in different profiles of crewmembers. Inherent to airline business, numerous destinations are flown at different frequencies, resulting in a myriad of passenger profiles and itineraries possible.

Airlines Operations is a very complex and challenging environment, which makes it quite attractive for operations research (OR). AGIFORS was founded by several airlines to help them optimizing their operations, but also tackle their challenges from the revenue management topics to maintenance topics, etc. With the evolution of technologies, increase in digitalization and data-driven operations, AGIFORS is still well supporting the airlines by fostering research and innovation, and the interest did not drop from the OR community.

---

<sup>3</sup> <https://publicapps.caa.co.uk/docs/33/SRG1846Issue01Enabled.pdf>

This global situation being set, the following sections aim at briefly introducing the different phases of optimization within airlines operations. This focus mainly on traditional airlines carriers that are operating a hub-and-spoke network from a major airport (called “hub”). The strategy is to bring passengers from an origin airport to the hub airport (e.g. Zurich in the case of SWISS) and enable through guaranteed connections a flight to their wished destination (Pels, 2021). Other descriptions can be found for Lufthansa in (Heger, 2018) or for TAP airline in (Castro, 2013). One day before departure, each flight is already assigned an aircraft tail (specific registration number), a cockpit and cabin crew, and the passengers booked on the flight are mostly checked-in and the complete itineraries are known. To achieve that, many processes and optimizations take place upstream, which is called the strategic phase (planning). On the day of operations, many events can occur, triggering the need for a solution. This is called the tactical phase (steering).

### **1.2. Strategical Phase (Planning)**

From 6 months up to two years in advance, the network department benchmarks new routes, decides to open, close, increase or decrease the frequencies of each route and assign a type of fleet to fly the route (short- or long-haul). The departure and arrival airport slots are negotiated each season with concurrent airlines, airport’s representatives, and the slot coordinator (see process (1) on Figure 1). The robustness of the network schedule undergoes many optimizations and simulations, each scheduled flight time and taxi times are adapted based on the experience gathered during the previous and on-going seasons. Indeed, when an airline uses a new type of aircraft flying more efficiently and faster, the flight time needed can be consequently reduced, and the schedule must be adapted. This results into a seasonal scheduled plan, allocating Scheduled Time of Departure, Scheduled Time of Arrival (STD and STA) and a type of aircraft for each flight (logical aircraft). As soon as the flights are published by the network, the passengers can book a seat (see process (2) on Figure 1). Seven days before the day of operations, an aircraft registration (physical aircraft) is assigned to each flight (see process (3) on Figure 1).

According to this plan, crewmembers’ roster is published around one month in advance according to the type of aircraft assigned to each flight (see process (4) on Figure 1). Indeed, depending on the aircraft type and the length of the routes, two to four pilots are required, and the minimum amount of cabin crew can greatly differ (linked with safety requirement, but also with the number of passengers booked on the flight). Due to overly complex duty time rules, from the airline itself (negotiated with the cockpit and cabin associations) and from the



European Union Aviation Safety Agency (EASA), intensive tailor-made optimizers and simulations core are necessary.

Finally, the flight steering on the day of operations (see process (5) on Figure 1) is explained in next section (section 1.3).



Figure 1: High-level summary of the processes around a flight.

### 1.3. Tactical Phase (Steering)

As the day of operations approaches, the dynamicity increases. Passengers that miss their previous flights must be rebooked on other flights. Some crewmembers might report sick, a standby crew is called to take over and reserve crews are activated into standby. An aircraft might have a technical problem – so-called Aircraft On Ground (AOG) – or be released later than planned by the maintenance department and cannot operate its scheduled as planned.

12 hours before departure, each flight has an assigned aircraft and crew, and a flight plan is automatically calculated according to the optimization of the flight planning system. Flight plan calculations are based on company routes prepared by a specific team and inputted in the flight planning system. It considers all the constraints imposed by the different countries like permit overflight and the more dynamic airspaces constraints, such as the Route Availability Document (RAD) or ConDitional Routes (CDR). Around four hours before take-off, the flight plan is filed to Eurocontrol (EUROCONTROL *et al.*, 2023).

As explained before, the European ATM reaches its capacity limits, and flying safely currently is enabled with increasing number of restrictions and so-called regulations. If an airspace reaches its capacity limit, a regulation is put in place, assigning Calculated Take-Off Time

(CTOT) to the flights that planned to cross this airspace. Airports can also be regulated in case of over demand towards capacity (caused by traffic peaks, weather, technical issues, or weather conditions for example).

The Calculated Take-Off Time often results in delay for the flights. This delay can spread across the other flights through aircraft rotations, crew rotations between aircraft or passenger connections that are awaited. If too much delay is spread on the operations, the Network Operations Control (NOC) team is responsible for finding a solution. The NOC can use a spare aircraft (named reserve aircraft) to operate the next flights of the delayed aircraft, can delay the next flight or can swap two aircraft to operate the flights on time. The last option is to cancel the next flights if no other solution is sustainable for the day of operations. Reserve aircraft are especially useful to reduce the reactionary delay due to other flights. It however costs greatly to an airline (an aircraft not flying means significant costs not covered by passenger revenue). The amount of each aircraft type that should be planned as reserve aircraft each day is a strategical decision between operations efficiency, robustness, and revenue.

Each time the NOC takes a decision, the rest of the Operations Control Center (OCC) is impacted. The dispatch team needs to refile the flight plan accordingly to the new Estimate Departure Time (ETD) and the new aircraft type. The crew control team needs to ensure that the right crewmembers are informed about the changes. The Passengers Control Center (PCC) needs to inform the passengers about delay, gate changes or even rebook some of the passengers missing their connections due to a delay or booked on a cancelled flight. The Hub Control Center (HCC) or the Ground Service Control Centers (GSCC – mainly responsible for the outstations) needs to coordinate the hub or the airports for the gate allocation, the need of specific equipment, the organization of buses for open tarmac or the organization of Direct Transfer (RDS –Direct Transfer Service) with airports authorities and services.

To represent most of the macro processes running in order to get the scheduled flights flying from origin to destination with the right crew, the right aircraft type, the right passengers and the most punctual possible, a temporal graph in Figure 2 summarizes the different actions to be done prior to EOBT (Estimated Off-Block Time). A good overview of an OCC example for processes and organization is provided for Lufthansa by (Heger, 2018).



Figure 2: Example of the processes necessary to operate a flight from an airline.

#### 1.4. Operational Disruption

Airlines disruption is defined as irregularities in the planning (Hassan *et al.*, 2021). Each year, the Central Office for Delay Analysis (CODA) report analyses the main causes for delay and disruptions (EUROCONTROL, 2022b). Without mentioning international pandemics like Covid-19, which led to a “simple” cancellation of all flights, major disruption types for the airlines are related to a fleet grounding (such as the A22X grounding in 2019 at SWISS due to several engine shutdown in flight<sup>4</sup>), weather conditions or industrial actions (strike) from ATM partners. This leads to inevitable cancellations and numerous delays. Smaller but more regular disruption types also occur such as an AOG, snowball effect from delay due to over demand in an airspace or at an airport, late crew, or late passengers. These delays are happening every day, and the operational team are quite well experienced dealing with these smaller daily disruptions.

Major disruptions such as industrial actions or weather conditions increased in the last years. During major strike events, such as the ones observed in France in December 2019 or in the first half of 2023, the airlines are asked to proceed to a mandatory cancellation of given percent of their flights flying from/to disrupted airports, or even only overflying the disrupted airspace. In 2023, in less than four months, (EUROCONTROL, 2023) reported that 34 days of strike in France impacted 237,000 flights, leading to a total of 10 million affected passengers, representing around 64,000 passengers per day unable to travel due to the strikes. The airlines

<sup>4</sup> <https://www.letemps.ch/economie/swiss-remet-service-airbus-a220>

reported in average – only between March 7<sup>th</sup> and the April 9<sup>th</sup> – 8 million of euros of costs due to cancellations, with additional costs for delayed flights estimated to 6 million per strike day. The impact on operations is massive.

### **1.5. Need for Optimization**

The previous sections highlighted some of the reasons why airlines operations are challenging. Any small deviation from the plan, be it a delay on an aircraft, a passenger with short connecting time or a crew reporting sick, results in the entire plan being reshuffled. In case of major disruption where delays and cancellations are the only option – if not mandatory asked by the ATC or airport authorities – the operational team must carefully consider all options and find out what combinations of flight delays, cancellations, passengers rebooking and crew plan adaptations could minimize the impact on the passengers and crews, the snowball effect on the consecutive hours and days of operations, as well as the costs. In summer 2023, as an example, SWISS is operating 87 SWISS aircraft and 12 wet lease aircraft of 10 different aircraft types, for which more than 1,200 pilots and 3,600 cabin crews are required<sup>5</sup>. Around 400 flights a day are carrying up to 60,000 passengers. The combinations for solutions are tremendously high, and neither the human brain, neither a computer can review all solutions in a limited amount of time. Therefore, a support for optimizing the operations in case of any variation of the initial plan is clearly needed, and even more when major disruption occurs.

In another hand, the airlines gathered in different groups and alliances through the last decades. This is – among other – enhancing the possibilities for passengers to reach their destination, but simultaneously also increasing the complexity of operations and solutions.

### **1.6. Airlines Group and Operational Coordination**

#### ***1.6.1. Airlines group Strategies***

Airlines strategically started to cooperate at different level (alliances or group) to handle the growing concurrence. Firstly, Airlines' alliances enable to broaden tremendously airlines' network of origins and destinations served, flight frequencies, and thus offers to the passengers attractive and flexible itineraries. It is based on the codeshare principle between two airlines (agreement that allows one airline to sell tickets for a flight operated by another airline one and *vice versa*). Secondly, the airlines group model such as Air France- KLM, LATAM or the Lufthansa Group aims to increase the hubs dominances, the airline's network attractiveness and market share, as well as enable easier passengers rebooking possibilities in case of delay

---

<sup>5</sup> <https://www.swiss.com/corporate/en/company/about-us/company-profile>

or cancellation (Alderighi and Gaggero, 2018). Cost reductions such as joint ground handling (luggage, gates and check-in counters, use of lounge, etc.) incentive also airlines alliances and grouping (Merkert and Morrell, 2012). Airlines group also helped to compete against the newcomers from the 1990's and 2000's, namely the low-cost carriers, dropping the ticket price, prompt to adapt to the market and with a high passenger's satisfaction. Creating a new airline with an independent business model similar to the low cost ones but as a complementary market segment to the airlines group businesses, enabled a successful and sustainable market offer for different passengers expectations (Raynes and Tsui, 2019).

However, a grouping of airlines implies stronger commitment, alignment and integration than an alliance and the strategic partners as well as internal organization must be carefully chosen, to ensure a benefice in performance improvement for all partners (Park and Cho, 1997). Generally, one airline acquires other airlines, and departments such as high-level strategy, pricing, revenue, even maintenance could be merged. In some cases (like United Airlines), previous OCCs of the different airlines are merged into one OCC monitoring all operations. In other cases, each airline remains independent, and a coordination is organized.

Many airlines group choose to leave a high autonomy to each airline of the group, as each one has different businesses, strategies, and operations, which are not similar, and often tailor-made for their local market and partners. This is the case of the Lufthansa Group airlines operations. During disruptions, the OCC managers coordinate the cancellations publication time together to avoid automatic rebooking of passengers to the other airlines' group flights, which are planned to be cancelled. However, each airline optimizes by itself its own disrupted operations and rarely considers the possibilities of deeper coordination with the other OCCs. This can be explained by the lack of common data source, of optimization tools existing across airlines as well as the challenge of agreeing on the best solution for the group, the fairness and the trust in a group system.

### ***1.6.2. Current Coordination Processes and On-going Projects***

Currently, the Lufthansa Group airlines are coordinating some decisions and are since a few years into a process of better data sharing. On the operational side, all OCCs are communicating their operations status and foreseen issues during the morning call around 06:00 LT. If any cancellation must take place at an outstation, the basic coordination described above takes place.

On the technological side, the Lufthansa Group is in a dynamic to share more and more common database (such as having only one database for all passengers booking on any of the Lufthansa Group airlines) and common tool to enable seamless collaboration between the OCCs. In this scope, a project for implementing a common movement control tool to all airlines is on-going, with SWISS, Austrian Airlines and Lufthansa City Line already on a same platform, and Lufthansa Munich and Frankfurt planning to join them in the coming years. A major project of operations optimization also started at SWISS called OPERATION S Decision support suite (OPSD), which aims at delivering data-driven operations thanks to optimizers designed and developed by the Google Operations research team<sup>6</sup>. This OPSD project is a Lufthansa Group project with SWISS acting as a pioneer, and the rollout of the first optimization features are currently taking place for Lufthansa Munich.

Once all airlines of the group will have these optimization features up and running on their local operations, the long-term vision is to enable a group-wide decision to reach better solutions for the airlines group passengers and operations steering. Opening the possibility to cancel and delay flights on one airline rather than another – but still meeting the required capacity reduction mandated by the airport authorities – is expanding the search space tremendously, meaning also that optimum solution for the group might be found. It is the objective of this thesis to propose a methodology enabling the group-wide optimization while keeping the sovereignty of each airline as a hard requirement.

### **1.7. Chapter Conclusion**

Nowadays, smart tools and decision-making supportive systems are being developed to help the OCC managers in their operational decisions, especially during disruption. The amount of data, decision variables and uncertainties are colossal. Current technologies already labor to incorporate the high volume of data necessary for decision for one OCC, with the dynamicity of the daily operations. Experience and verbal information sharing cannot always be incorporated in a tool, even powered by Artificial Intelligence (AI) technics. The OCC teams, with their cumulated years of experience, can identify critical flights while processes on big data would fail to, as they are missing live information not already entered (or not considered) in the system. Optimization support are more than needed, but the final decision must be made by an expert.

---

<sup>6</sup> [SWISS Case Study | Google Cloud](#)

Multiple disruptions take place every year, due to industrial actions from ATC, ground handling at the airport, weather, etc. This leads to mandatory cancellations from each airline impacted by the disruption, as well as delay on operated flights. The operational staffs have limited time to find the best combinations of cancellations and delay minimizing the impact on their operations. Moreover, the operations optimization is already a challenge at the scale of one OCC, as the coordination within OCCs for a common decision on flights to be cancelled can be very delicate and sensitive. In the case of multiple OCCs, operating from different hub airports, each airline protects its sovereignty and decides according to their local market segment, business strategies, local partners' information, and processes.

The originality of this thesis is to extend the optimization need to several airlines willing to collaborate. It assumes that a benefit exists from a multi-airline operations optimization under disruption. The solution space should increase tremendously, and the hypothesis is that better solution should arise. This however raises many questions: operations are all different from one airline to the other, even in a same group or alliance. What should be the right decision variables for a group optimization? How many constraints and specificities of each airline can we consider while respecting the computing time limitations? How to evaluate whether a solution is good or not from a group vision? How to ensure that the airlines accept the group process and the solution of a group optimization, even if it might be sometimes disadvantageous for them? And finally: how to grant that the group optimization process not only brings benefits to the airlines group, but also ensured equity on the long-term?

Due to the complexity of operations optimization, the operations community is very active on this topic. The next chapter will present a literature review on the airline's operations optimization challenge, to highlight the achievements reached and the shortcomings to still address in a multi-airline optimization.

## 2. Literature Review on Airlines Operations Optimization

As stated in Chapter 1, airlines operations optimization is a privileged field for operations research. Numerous research articles were published since AGIFORS creation, and several recent articles present an extensive literature review about that subject (Hassan *et al.*, 2021; Su *et al.*, 2021). The goal of this chapter is to go through the main scientific publications about airlines operations optimization and airlines disruption optimization, that are commonly categorized through different axes:

- Aircraft rotations and assignment optimization;
- Crew optimization;
- Passenger optimization;
- Semi-integrated and fully integrated optimizations (aircraft & crew optimization, aircraft & passenger optimization, or aircraft & crew & passenger optimization).

(Hassan *et al.*, 2021) presented an illustration of the number of publications per recovery type per year (Figure 3). It is worth mentioning that the number of scientific papers published since 2015 is more than twice higher than in the first decade of 2000. This graph shows the growing interest into the airlines' operations optimization.

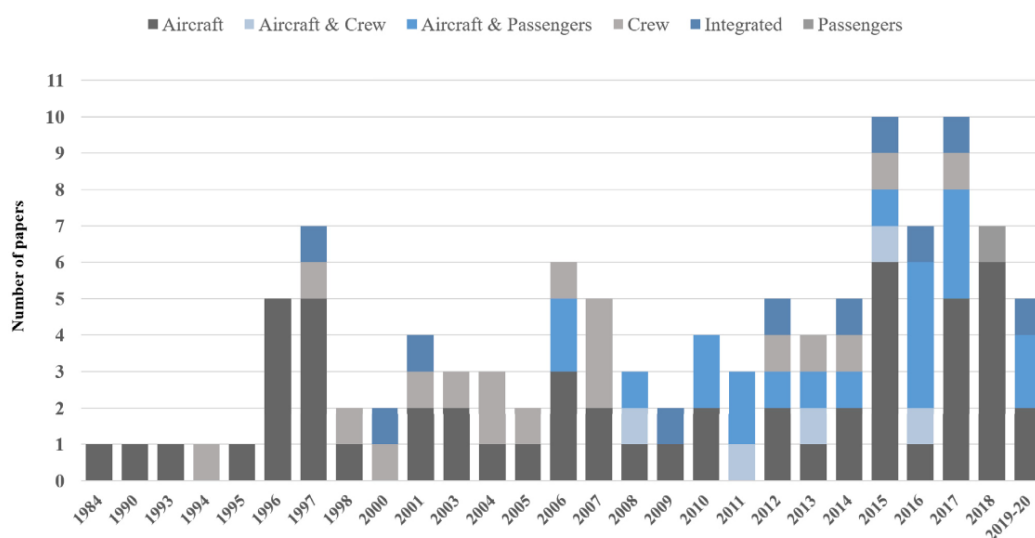

Figure 3: Number of publications per recovery type per year (Hassan *et al.*, 2021).



Each one of the optimization axes listed above are well known for being NP-hard problem, which explains why research on these topics is still continually active. Moreover, the airlines start only since a few years to integrate optimizer and decision-making system in their daily operations. The following subchapters present the aircraft recovery literature first, then the aircraft and passenger recovery, followed by the crew recovery, the integrated recovery approaches, and finally a short summary about the multi-airline operations optimization. It must be noted that most of the scientific literature on these subjects targets the hub-and-spoke airlines framework.

### **2.1. Aircraft Planning Recovery**

The aircraft planning optimization goal is to find a new planning of flights to reduce the disruption impact on the operations. As explained in section 1.2, the initial assignment of aircraft to operate flights results of multiple optimizations from the network department. This is coordinated with the revenue management department to assign the right aircraft type to each flight, depending on the passenger demand. During the tactical phase (see section 1.3), the challenge of the aircraft planning recovery consists in finding the smartest combination of delays, cancellations but also aircraft equipment change (aircraft swap or usage of reserve aircraft). For example, an equipment change is done to avoid delay spreading through an aircraft rotation or accommodate more passengers with increased aircraft seat capacity. This is the major problem to solve before considering any optimization of passengers or crews. If a flight does not have an aircraft to be operated on, the passengers will be disrupted, as well as the crew. A smart assignment of aircraft and delays on flight is primordial to optimize airline's operations.

(Teodorović and Guberinić, 1984) were pioneer with the first aircraft recovery OR approach considering eight flights operated by three aircraft, of which one is AOG due to a technical problem. The authors made the hypothesis that all aircraft are identical (same aircraft type). The optimized planning is generated through the Branch-and-Bound method. Even if the problem seems rather simple in comparison with real operations, this first step of applying optimization method to the aircraft recovery problem is a big first step. (Mathaisel, 1996) demonstrated that a decision-making user interface is essential for an efficient steering of the operations during a disruption. Whatever the complexity of the solutions proposed by OR algorithm is, a seamless communication and clear graphic representation tool is a key in disruption management. This was tested on a slightly bigger problem size (6 aircraft operating 38 flights, of which one aircraft is AOG). (Clarke, 1998) tackled the flights rescheduling

problem solved through greedy heuristics, column generation methods and branch and bound solution procedures. The author applied a simplified approach (relaxed constraints from maintenance and basic crew aspects) on case study with 201 flights operated by 42 aircraft and different types of disruption (flight delay, aircraft AOG, etc.).

Since the 2000's, numerous methods on increasing problem size have been presented. (Bierlaire *et al.*, 2007) applied a column generation method based on a multi-commodity network flow to instances provided by Thomas Cook airline. They highlighted the effect of considering maintenance events on the solutions quality, with problem size up to 16 aircraft operating up to 242 flights. (Liu *et al.*, 2008) proposed one of the first multi-objective function and used a genetic algorithm with solution assessment based on Auxiliary Vector Performance Index method. They tried to simultaneously minimize five objectives: the ground time violations, the number of ferry flights needed due to discrepancies between the arrival airport of a flight and the departure airport on the next flight operated on the same aircraft (flight connections), total flight delay time, number of flight swaps and maximum delay. They also were the first ones to apply their approach on a mixed aircraft types fleet (MD90 and DH8) after Clarke, even if aircraft swap inter fleet was not considered. The authors reported, as most of authors before them, the difficulty to propose a precise mathematical model due to the high number of factors to be considered and their high dynamicity. Based on the same data, (Liu *et al.*, 2010) enhanced their approach with a hybrid multi-objective genetic algorithm to solve the daily short-haul aircraft recovery problem in a shorter computation time (around 4 min in average). They demonstrated that their hybrid method, incorporating an adaptive evaluated vector to better guide the solution, outperforms their latter approach. (Sousa *et al.*, 2015) based their approach on the ant colony optimization. While the computing time was not competitive with the already existing algorithm in the literature, the best-known solution were systematically reached (applied on problems from 20 to 100 flights). (Hu *et al.*, 2017) developed a multi-objective heuristic combining  $\epsilon$ -constraints method and neighborhood search algorithm to minimize the total deviation with the initial schedule, the maximum delay, and the number of aircraft swaps. They demonstrated that this method is particularly efficient for large-scale disruption (up to 104 aircraft from the same type, operating 410 flights).

Recently, multiple methods have been used, seeking for always more time-efficient algorithm taking into consideration as much as possible the real complexity of the operational situation and its dynamicity. (Liang *et al.*, 2018) added to the aircraft recovery problem not only maintenance constraints, but also airport capacity constraints and tested it on large-scale

disruption (up to 638 flights). They used a column-generation based heuristic, aiming at minimizing operational costs, with the master problem being to assign flights to aircraft considering the limited airport capacity and the sub-problem being the incorporation of swapping maintenance events. The large-scale problems were solved within 6min with only small optimality gap. (Rhodes-Leader *et al.*, 2018) highlighted the problem of high computational costs using high-fidelity simulation and proposed a new approach using simulation model including a trust region simulation optimization algorithm to provide a good estimation of the solution performance. While the results compared with the “do-nothing” scenario are not showing a revolutionary approach, the importance of simulating the consequences of a solution is highlighted in this paper, especially if one wants to consider more accurately the complexity of real operations. (Hondet *et al.*, 2018) proposed Reinforcement Learning (RL) techniques to minimize the costs of aircraft swaps (no delay nor cancellations) on a fleet of six aircraft. While the results were better than the “do-nothing” solution, the agent were trapped by local optima. This however opened the door for further reinforcement learnings technics to apply on the aircraft recovery problem. (Woo and Moon, 2021) proposed three different approaches to minimize the operational costs (costs of delay, connections rates and cancellations): a greedy approach providing a solution based on the current available arrival slots at an airport, a stochastic approach considering the uncertainty of the arrival capacity being further decreased by the airport, and a min max approach modelling a conservative airline approach (minimizing the costs in the worst-case scenarios in case of further capacity decrease). The maximal computing time (20 minutes) were reached by all three approaches. This was one of the first approach considering uncertainties in the arrival slots published, and opened the door of methods including uncertainties within the aircraft recovery problem, which is scientifically and operationally well needed, to come closer to the operational reality. (Lee *et al.*, 2022) proposed a reinforcement learning method on airport closure use-cases for multi-fleet aircraft recovery. The goal was to better estimate and solve the aircraft recovery problem while optimizing the on-time performances of the airline, which they consider as the major driver for passenger satisfaction and airline’s reputation. It showed promising results thanks to decision to delay and cancel flights with adequate rewards to the Reinforcement Learning agents. (Zhao *et al.*, 2023) solved the aircraft recovery problem considering the uncertainty of the disruption duration. The time-based network model aims at lowering the impact on operations (through as few curfew violations and variation measurement from the initial schedule). Each new schedule is evaluated through costs such as the sum of total passenger delay costs or cancellation costs. A comprehensive review of

## Chapter 2 - Literature Review on Airlines Operations Optimization

research article on the aircraft recovery problem was recently published for more details (Santana *et al.*, 2023).

Table 1: Overview of the articles reviewed in the aircraft planning recovery.

Scientific Article	Method / Contribution	Objective	Performances / Problem Size
(Teodorović and Guberinić, 1984)	Branch-and-bound.	Minimize passengers delay.	3 aircraft (same aircraft type) with 8 flights, 1 aircraft AOG.
(Mathaisel, 1996)	Demonstrated the importance of clear graphic representation of the problem and solution.	Minimize estimated costs due to delay and cancellations.	6 aircraft (same aircraft type) serving 19 destinations with 38 flights. 1 aircraft AOG.
(Clarke, 1998)	Greedy heuristics, column generation methods, and branch and bound solution procedures	Minimize estimated costs due to delay and cancellations.	42 aircraft (different aircraft types) operating 201 flights.
(Bierlaire <i>et al.</i> , 2007)	Column generation method based on a multi-commodity network flow model.	Minimize costs (of delay and cancellations) and makespan (recovery time).	From 5 to 16 aircraft (same aircraft type) operating from 38 to 242 flights. Airport closure as a disruption.
(Liu <i>et al.</i> , 2008)	Multi-objective Genetic Algorithm (Auxiliary Vector Performance Index).	Minimize ferry flights number, ground time violations, total flight delay time, flight swaps number, and number of flights with more than 30-minutes delay.	7 MD190 operating 70 flights, 12 DH8 operating 149 flights. 11 different destinations. 2 airport closure for 1 hour due to thunderstorms.
(Liu <i>et al.</i> , 2010)	Hybrid multi-objective Genetic Algorithm with an adaptive evaluated vector to guide the solution. Faster computation time.	Same as (Liu <i>et al.</i> , 2008).	Same as (Liu <i>et al.</i> , 2008).
(Sousa <i>et al.</i> , 2015)	Ant Colony Approach.	Minimize operational costs.	From 20 to 100 flights from TAP.
(Hu <i>et al.</i> , 2017)	Multi-objective heuristic combining $\epsilon$ -constraints method and neighborhood search algorithm.	Minimize the total deviation with the initial schedule, the maximum delay, and the number of aircraft swaps.	104 aircraft (all Boeing 737) from a major Chinese carrier operating 410 flights.
(Hondet <i>et al.</i> , 2018)	Reinforcement learning (Q learning) for aircraft swap decision.	Minimize operational costs	6 Vueling aircraft.
(Liang <i>et al.</i> , 2018)	Column generation method, considering airport capacity and maintenance events.	Minimize operational costs.	638 flights, data from SABRE Airline Operations Research Competition organized in 2016.
(Rhodes-Leader <i>et al.</i> , 2018)	Multi-fidelity modelling.	Minimize operational costs, delays and total deviation from the initial schedule.	8 aircraft, 15 destination, 54 flights, 1 aircraft AOG.
(Woo and Moon, 2021)	Greedy, stochastic, min max. approaches including the uncertainty for further capacity reductions.	Minimize operational costs (delay, misconnection, and cancellation costs).	71 flights, only delays.
(Lee <i>et al.</i> , 2022)	Reinforcement learning method with adequate rewards strategies.	Maximize on-time performance. Only aircraft swaps and delays allowed.	7 aircraft, 70 flights, 4 airports, 1 airport closure.
(Zhao <i>et al.</i> , 2023)	Time-based Network model.	Reduce delayed passengers costs, cancellation costs, curfew violations costs and initial schedule variation.	73 aircraft operating 207 flights.

This short and non-exhaustive literature review on the Aircraft Recovery Problem summarized on Table 1 shows the myriad of methods, approaches, and objectives. Starting from small-scale problem with two aircraft involved, the scientific papers tackled bigger scale problems with the time, and tried out all sorts of methods to optimize and reach the best solution possible. No perfect solution arises from the research, each one having their own advantages and limitations. For some of them, the computation time is short as required by most operational users (below 5 minutes), but the real complexity of the operations is not considered, and many simplifications are done. For some other ones, the computation time is very long (up to 20

minutes for (Woo and Moon, 2021)) but it considers the uncertainties and dynamic characters of real airlines operations. No approach tackle fully the complexity of the aircraft recovery problem, as many data are needed for that (from airlines) and as the dynamicity of the operations cannot be properly reproduced in a research environment. Some approaches propose as mitigation measures to delay, cancel flights, organize ferry flights, or swap aircraft while some other concentrate on only one mitigation measure. The need for high fidelity simulations models or trustful evaluation of the solutions proposed were also recently addressed, as well as the need for incorporating uncertainties to reach sophisticated indicators.

In conclusion, the aircraft recovery problem is still a particularly challenging field of research. Combined with the tremendous traffic growth, this research area has a significant importance for airlines industry and ATM. It is very active – as shows Figure 3 with the increasing number of publications – with promising thoughts and methods, but still necessitates future research. Multiple methods were proposed (heuristics, metaheuristics, reinforcement learning, etc.), although its efficiency and significance rely on the airline or on the researchers to tackle one side of the problem more than another, depending on the interests and business targets. The simplifications in the modelling of the problem are crucial for an efficient optimization but must also be carefully chosen to ensure a still realistic consideration of the real operational complexity. While the reinforcement learning approaches seems to require more maturity to offer stable and reliable optimizations, the metaheuristics-based methodologies present quite promising and interesting applications.

## **2.2. Aircraft and Passengers Recovery**

Finding the best assignment of delay, cancellation, sometimes even proposing aircraft swaps, cannot be evaluated only on pure scheduling objectives. The primary mission of an airline is to transport safely passengers from their origin to their destination. Evaluating only the delay and cancellation costs without considering if the passenger can reach in a due time their destination is a gap that is addressed with the Aircraft and Passengers Recovery Problem.

The passenger optimization aims at finding the best new allocation of passengers on itineraries according to delayed or cancelled flights, to reduce the impact of a disruption. Passengers for which a flight is delayed or cancelled are called “disrupted passengers” in the literature, and the flight sequence to fly from their origin airport to their planned destination airport is called an itinerary. The passengers being the main users of the air transportation, it is the heart of the

airlines business model to recover as much as possible with satisfying solutions for their passengers. In a hub-and-spoke airline, passengers' connections bring a high-dimensional complexity, through all the possibilities and different itineraries, classes, fares, statuses that each passenger can have. This results in a huge number of variables.

The passenger possible alternative itineraries are usually represented as a graph where flights are nodes, arcs are feasible connections between flights, with capacity and costs corresponding to the seat available and the down/upgrading and costs of delay for the alternative. The graphs vary from the articles, according to the optimization methods targeted as well as the granularity of data available.

(Zegordi and Jafari, 2010) tackled the aircraft recovery problem through an ant colony optimization, considering the disrupted passengers as one of the objective functions. However only 2% of the passengers in their datasets were having a connection and no intelligence is optimizing the passenger itineraries. They demonstrated interesting early results and highlighted the need for truly integrated approach to better support real airlines operations. Although some early research happened before, most of the publications about the passenger recovery problem followed the ROADEF (société française de Recherche Opérationnelle et d'Aide à la Décision) challenge of 2009. The datasets, on which the competitors' approaches were evaluated, included up to 256 aircraft operating 1,423 flights to 45 different airports, with up to 1,565 passenger itineraries planned. The disruptions were mainly flight delays, airport capacity restrictions and aircraft AOG. The computation time was limited to 10 minutes maximum. (Bisaillon *et al.*, 2011) won the competition thanks to a large neighborhood search heuristic combining fleet assignment, aircraft routing and passenger assignment. They optimized the disrupted passengers through solving repeatedly the shortest path problems for each itinerary. Passenger itineraries are treated by decreasing order of importance (linked to the costs in case of cancellation). The proposed heuristic alternates: construction phase proposing an initial solution for the aircraft recovery problem, repair phase to decrease the number of infeasible flights and give a first assignment of disrupted passengers on their shortest paths and improvement phase to iteratively delay some flights to potentially accommodate more passengers. (Jozefowicz *et al.*, 2013) ranked in the finalist with an approach based on a three-step heuristic (called NCF: New Connections and Flights), first cancelling flights, then trying to assign passengers based on the shortest path search and finally adding flights to attempt finding a suitable solution for the remaining disrupted passengers. The principal difference with the winning method from (Bisaillon *et al.*, 2011) is that the NCF never modifies

passengers itineraries that are not classified as disrupted. (Sinclair *et al.*, 2014) proposed new refinements on the large neighborhood search heuristic from (Bisaillon *et al.*, 2011), enabling better exploration through the search space. They extended each phase with small additional steps, refining the solution proposed at the end of each phase (using models such as the longest path problem, multi-commodity flow problem or shortest path problem). They demonstrated that these additional steps saved computation time by targeting more sensitive solutions as from the construction phase. Thereafter, the same authors modelled the aircraft and passenger recovery problem as a mixed-integer program and solved it through a column-generation post-optimization heuristic (Sinclair *et al.*, 2015). They ran it after their improved Large Neighborhood Search approach as a complementary step. For big instances, the column generation heuristic is used only to solve the multi-commodity flow problem for the passengers to remove complexity. They improved the best-known solutions in a reasonable computing time. Another approach proposed by (Acuna-Agost *et al.*, 2015), also based on the ROADEF 2009 data, enabled the use of efficient integer programming thank to a network pruning algorithm significantly decreasing of the problem size. (Maher, 2015) adopted a column-and-row generation to decide about delays and cancellations, which seemed to be faster than a column generation model. (Hu *et al.*, 2016) introduced a heuristic based on a Greedy Adaptive Search Procedure (GRASP) algorithm, which reaches an optimal passenger reassignment in each iteration, minimizing the passenger related costs (due to delay, rebooking and compensation). (Zhang *et al.*, 2016) worked on a math-heuristic in three steps, first assigning the aircraft to the flights, then solving iteratively the flight schedule and re-assigning the passengers. To this end, they used a time-space network model with a mixed-integer programming model. (Arıkan *et al.*, 2016) modeled the aircraft and passenger recovery model as a mixed-integer non-linear program and reformulated the cost associated with fuel consumption as a conic quadratic mixed-integer programming model, to show the impact of speed variations as a recovery method.

Recently, some authors started to consider passengers preferences. (Yang and Hu, 2019) built a model taking into consideration the passengers preferences between delay and cancellation and used a multi-objective genetic algorithm to solve the problem. (Vink *et al.*, 2020) proposed to pre-compute a delay cost matrix of passengers with direct flights or connections, formulated the problem as a mixed-integer linear problem and solved it dynamically. Very interesting is that the authors find a near-optimal solution within less than 30s in average. (Hu *et al.*, 2021) studied the aircraft and passenger integrated recovery considering that passengers might not

## Chapter 2 - Literature Review on Airlines Operations Optimization

accept the rerouted itinerary offered by the airline. They constructed an integer-programming model to minimize airline recovery costs and decrease passenger recovery loss, and use bounded rationality to formulate the passenger recovery loss. They then solved the problem via a heuristic combined with multi-directional and stochastic variable neighborhood search algorithm.

A math-heuristic approach was developed on the integrated aircraft and passengers problem with additional complexity, such as the possibility to speed up some flights (Naz Yetimoğlu and Selim Aktürk, 2021). Depending on the fuel costs, this additional flexibility might be useful to reduce passengers with missed connections before curfew, or be too costly for the airline. Table 2 provide an overview of the articles reviewed, with their methods, objectives, and performances.

*Table 2: Overview of the literature review for the aircraft & passenger recovery problem.*

Scientific Article	Method / Contribution	Objective	Performances / Problem Size
(Jafari and Zegordi, 2010)	Ant Colony Optimization with disrupted passengers as part of objective function.	Minimize operational costs (delay and cancellation of passengers).	13 aircraft (2aircraft types) operating 100 flights to 19 different airports. Transporting 2,236 passengers with 8 different itineraries and 55 connecting passengers.
(Bisaillon <i>et al.</i> , 2011)	Large Neighborhood Search in three phases (construction, repair, improvement).	Minimize operational costs.	ROADEF CHALLENGE 2009 data:  Up to 256 aircraft operating 1,423 flights to 45 different airports, with up to 1,565 passenger itineraries planned. Computation time limited to 10 minutes maximum.
(Jozefowicz <i>et al.</i> , 2013)	Heuristic based on the shortest path.	Minimize operational costs.	
(Sinclair <i>et al.</i> , 2014)	Improvement of the Large Neighborhood Search from (Bisaillon <i>et al.</i> , 2011)	Minimize operational costs.	
(Sinclair <i>et al.</i> , 2015)	Mixed-integer program solved by column-generation post optimization heuristic	Minimize operational costs.	
(Acuna-Agost <i>et al.</i> , 2015)	Network pruning algorithm to decrease the problem size pour réduire la taille de la programmation en Nombre Entiers	Minimize operational costs.	
(Maher, 2015)	Column-and-row generation	Minimize operational costs.	
(Zhang <i>et al.</i> , 2016)	Math-heuristic in three steps, based on a time-space network model with a MIP.	Minimize operational costs.	
(Arkan <i>et al.</i> , 2016)	MIP considering speed variations	Minimize operational costs including fuel costs linked with speed	Data from a major US carrier (up to 1,429 flights).
(Hu <i>et al.</i> , 2016)	GRASP	Minimize passengers costs (delay, rebooking, compensations).	87 aircraft from a major Chinese carrier (Boeing 737) operating 340 flights.
(Yang and Hu, 2019)	Multi-objective genetic algorithm considering passengers preferences between delay or cancellation.	Minimize operational costs and passengers' dissatisfaction.	59 aircraft operating, 209 flights from 3 hubs and 24,860 passengers.
(Vink <i>et al.</i> , 2020)	Pre-compute a delay cost matrix for passengers costs evaluation. MILP.	Minimize operational costs.	Examples of small disruption from a US carrier operating to 100 aircraft with 600 flights (2 aircraft types).
(Hu <i>et al.</i> , 2021)	Heuristic approach with multi-directional and stochastic variable neighborhood search algorithm, considering the uncertainty of passengers acceptance of the solution.	Minimize operational costs and passengers' dissatisfaction	Data from Air China: 276 aircraft with 11 aircraft types, operating 1,038 flights with around 120,000 passengers.
(Naz Yetimoğlu and Selim Aktürk, 2021)	Math-heuristic considering speed variations.	Minimize operational costs (passengers + fuel).	5 aircraft based in ORD with 18 flights and around 2,000 passengers.

As this short literature review showed, scientific breakthrough for the aircraft and passengers recovery problem followed the ROADEF Challenge 2009. This fostered the researchers to propose different methods and refine further their approach to seek for the right balance between computation time and solutions optimality.

Most of the methods proposed are optimizing iteratively the aircraft problem (propose a new planning with flight schedule and aircraft assignment) and then evaluate for this new planning if the passengers can be satisfyingly rebooked. These iterative approaches are the



most successful if combined with metaheuristics approach for the aircraft optimization. While different heuristics and metaheuristics proposition optimize the aircraft problem, the most common approach to optimize the passenger itineraries relies on graphs optimization such as using a multi-commodity flow problem or min costs max flow problem optimization. (Acuna-Agost *et al.*, 2015) approach and modeling is particularly interesting for its genericity and its efficiency in the optimal solutions search.

Recently, some authors expended the actions influencing the schedule optimization, such as speeding up the flights. Moreover, the uncertainties that some passengers might not accept the proposed delay or cancellation gets more and more consideration and are integrated into the passenger optimization.

The aircraft and passenger recovery problem still generates multiple interesting concepts. Being at the heart of airline business, the passenger problem presents an increasing complexity, not only through the data volume available, the extension to uncertainties considerations and recovery options, but also because of the increasing traffic and passenger demand. Finding acceptable solutions for all passengers in case of disruption is a continuously more challenging problem, requiring faster and more efficient optimization methods.

As also briefly explained in section 1.6.1, alliances within airlines, be it on a code-share level or on a deeper grouping of airlines, are offering more flexibility for rebooking passenger itineraries. Nevertheless, this increases the number of data to consider, rules to add and consequently the number of possible solutions to the passenger recovery optimization methods, leading to longer computing time. The number of variables to consider is high, and therefore a true integrated method optimizing simultaneously the aircraft problem with the passenger problem is unrealistic.

### **2.3. Crew and Aircraft & Crew Recovery**

The crew optimization targets finding optimal crew assignment given delayed or cancelled flights as well as sick or late crewmembers. The crew assignment is done into two steps: first, the crew pairing optimization (identifying which flights rotations, duties, and night stops sequence, without assigning any crewmembers) and then crew roster optimization (assigning a crew to a duty, with duty time limits, qualifications constraints, etc.). Crew recovery and aircraft & crew recovery optimization methods truly progressed with the increasing complexity of crew rules within airlines and cross-countries institutions (such as the EASA in Europe).

Duty rules and limits are regularly subject to negotiations with the crew unions and updated to face the growing traffic to operate. The crew recovery problem might be one of the hardest one from the complexity perspective, as the complicated rules must be dynamically implemented with all changes happening in an airline, and that a suboptimal solution for the crew might end up in further disruptions, sometimes unplanned, for the whole operations (Brucker *et al.*, 2011).

(Guo, 2005) presented in his PhD thesis several methods to tackle the crew recovery problem and compared them. A direct solving method based on mixed-integer optimization models was first designed. As it was reaching its limits with increasing problem size, a column-generation approach optimized the crew recovery problem with its sub-problem solved by a constrained shortest path algorithm using dynamic programming. As the computing time was restricted, two heuristics (GA based heuristic and a constructive greedy algorithm) were proposed. The column-generation method was faster and with a more acceptable computation time (~10 minutes) for larger disruptions than the mixed-integer optimization models solving optimally. (Nissen and Haase, 2006) introduced a duty-period-based formulation with a solution method based on branch-and-price, enabling short computation time for providing solutions. (Medard and Sawhney, 2007) worked on several approaches to tackle the crew recovery problem at the day of operations: depth-first search with integer programming, and a column generation approach to produce solutions according to a lower bound coupled with shortest-path algorithm to find the cheapest solution. As for the previous articles, the column-generation approach was more efficient for medium to large-scale problems. (Gao, 2007) addressed crew and aircraft recovery problem based on a Bender's decomposition solution approach, using a multi-commodity network flow model for maintenance routings.

Multiple metaheuristics-based methods were proposed since 2010 on the crew recovery problem only. (Azadeh *et al.*, 2012) proposed the first approach based on a particle swarm optimization for the crew-scheduling problem, with better results than the GA approach. A local search enabled to improve the algorithm outputs. (Chang, 2012) addressed the pilot recovery problem with a genetic algorithm. The originality of the method is to suppress the notion of rotation generation and solve the crew problem directly with the flight legs. (Liu *et al.*, 2013) introduced the notion of intra and inter-fleet models for the crew recovery problem that they optimized with a simulated annealing algorithm. They demonstrated that the inter-fleet model enables to increase the search space and find better solutions for the flight attendants problem. (Chen and Chou, 2017) proposed the first multi-objective optimization for crew recovery problem. They used an evolutionary approach to optimize crew rosters on

several day, first formulated the problem as a multi-objectives and multi-constraints combinational optimization problem and then explored the Pareto solutions found through a non-dominated sorting genetic algorithm II.

(Abdelghany *et al.*, 2008) developed one of the first crew and aircraft recovery approach. The authors proposed a greedy optimization in a rolling horizon framework to find an initial solution and then formulated the recovery problem as a mixed integer program. Although solutions were found in a record time (less than 1 minute), the accuracy of the new plans were lacking some operational complexity as the crew constraints were heavily simplified and crews were considered as a standard resource (same as an aircraft being considered a resource). (Aguar *et al.*, 2011) designed a genetic algorithm to optimize aircraft problem, that proposes a solution for which a flight-graph based meta-heuristics (hill-climbing, simulated annealing, and genetic algorithm) approach optimize the crew problem. They proposed a multi-objective evaluation of the solution before adapting the function with weights to correctly reflect a more reliable operational assessment of the solutions. The simulated annealing algorithm performed the best. (Zhang *et al.*, 2015) proposed – in a first step – to recover the aircraft problem modeled by a multi-commodity network model, and the recover the crew schedule problem through a new multi-commodity model. A benchmark with the method proposed by (Abdelghany *et al.*, 2008) showed that the solutions were presenting a good quality within 2 minutes of computation time. (Maher, 2016) proposed a column-and-row generation method, only evaluating passenger costs without any rebooking. (Parmentier and Meunier, 2020) presented a compact integer programming formulation for the aircraft solved efficiently through MIP solvers. They coupled it with a column generation formulation of the crew problem and applied it on Air France largest instances. What is particularly interesting is their declared intention to use simple approaches to fit in the airline current setting. Only few articles consider this operational reality. Recently, (Ben Ahmed *et al.*, 2022) proposed a mixed-integer programming model solved thanks to a matheuristic method. The maintenance restrictions are considered, as well as robustness, defined as a restriction for tight connection as well as increasing crew connections between two flights operated by different aircraft.

## Chapter 2 - Literature Review on Airlines Operations Optimization

Table 3: Overview of the literature review for the crew and the crew & aircraft recovery problem.

Scientific Article	Method / Contribution	ARP*	CRP**	Objective	Performances / Problem Size
(Guo, 2005)	MIP, GA, constructive greedy algorithm.		X	Minimize operational costs (driven by crew costs).	Up to 1,286 flights operated by 188 crew members on 10 days. Disruption through unavailable crew members.
(Medard and Sawhney, 2007)	Depth-first search and MIP, column-generation with estimation of lower bound coupled with shortest-path algorithm to find the cheapest solution.		X	Minimize the number of illegal crew, the number of remaining open time crew positions, and the number of affected crews.	Time window of 48h, considering up to 20,000 crew members. Solutions not always found.
(Abdelghany <i>et al.</i> , 2008)	Greedy optimisation in a rolling horizon framework to find an initial solution. Recovery problem formulated as a mixed-integer program (MIP).	X	X	Minimize operational costs of delay, resources reassignment, and cancellation.	522 aircraft, 1,360 pilots, 2,040 cabin crew members, operating 1,100 flights to 112 destinations. Delay on 3 airport.
(Aguiar <i>et al.</i> , 2011)	Flight graph-based approach with metaheuristic (hill-climbing, simulated annealing et genetic algo) optimization algo. First aircraft recovery then crew recovery.	X	X	Multi-objective function for delays and operational costs and adaptation with weights to correctly reflect the operational assessment.	Tested on 4 instances with 51 aircraft and 3,521 for 1 month.
(Azadeh <i>et al.</i> , 2012)	Discrete Particle Swarm Optimization with local search.		X	Minimize crew costs.	Up to 110 flights.
(Chang, 2012)	Eliminates rotation generation and directly assign flights to crew. Solved thanks to genetic algorithm.		X	Minimize crew costs.	668 leg operated by 70 pilots. 24 flights disrupted.
(Liu <i>et al.</i> , 2013)	Introduced the notion of inter-fleet models for cabin crew recovery. Solved with Simulated Annealing		X	Minimize the number of flight not covered by a crew.	Up to 640 flights operated by 81,173 crew members.
(Zhang <i>et al.</i> , 2015)	Multi-commodity network model for the aircraft problem, and then for the crew problem.	X	X	Minimize operational costs.	70 aircraft operating 351 flights with 134 crews.
(Maher, 2016)	Schedule, crew and aircraft recovery are solved using column-and-row generation.	X	X	Minimize operational costs(incl. passengers delays and cancellations).	Point-to-point model: 262 flights operated by 48 aircraft and 79 crews. Hub-and-spoke model 441 flights operated by 123 aircraft and 182 crews.
(Chen and Chou, 2017)	Multi-objective evolutionary algorithm based on NGSa II.		X	Minimize the effect of flight duty changes and the overhead from a change in flight time.	270 pairings operating 1,048 flights.
(Parmentier and Meunier, 2020)	IP for aircraft problem and column generation formulation for the crew problem.	X	X	Minimize the operational costs.	From 669 flights with 130 crew pairings to 3,398 flights with 690 crew pairings.
(Ben Ahmed <i>et al.</i> , 2022)	Mixed-integer programming model solved through a matheuristic method.	X	X	Maintenance restrictions and robustness (limit tight connections and crew connections with aircraft change).	202 aircraft operating 646 flights.

\*ARP: Aircraft Recovery Problem  
\*\*CRP: Crew Recovery Problem

This literature review is naturally based on the methods used to tackle the crew recovery problem, that are summarized in Table 3. As explained in the section 1.3, the complexity is significant due to the numerous rules applying international laws (such as the one from EASA) and the internal ones (negotiated with the crew unions). These rules sets are unique for each airline, and the more destinations, aircraft types and crew qualifications exist, the higher the complexity. Most of the scientific papers are simplifying the rules to keep the complexity under control. One can remark that many of the scientific articles are basing their approach either on the column-generation methods and its derivative or on metaheuristics approaches. At SWISS, the core optimizer powering the crew planning, as well as the solver used in operations during disruption (such as flight delays or sick crewmembers) is also based on column-generation based algorithm<sup>7</sup>.

<sup>7</sup> <https://news.jeppesen.com/news-room/swiss-signs-jeppesen-crew-tracking-services/>

The crew and aircraft recovery problem is very complex, and is intrinsically linked with the airline business and rules. Imagining a multi-airlines crew recovery system seems out of scope for now for any multi-airlines disruption, as this would necessitate great work of alignment and negotiations between the airlines and crew unions, which is rather unrealistic given the current challenges to find common alignment only between one airline and its crew unions.

## 2.4. Integrated Recovery

Passengers and crew optimization relies on a disrupted schedule that has been optimized before. An integrated approach consists in optimizing the passengers and crews in combination with the aircraft planning optimization. This enables to find embedded – thus more optimized and operationally interesting – solutions. However, the multiple variables and constraints specific to each problem require a step approach assessing the solution of each sub-problem on the other ones.

(Lettovsky, 1997) introduced in his PhD thesis one of the first integrated method to tackle the aircraft routing, passengers flow and crew assignment problems. The author presented a linear mixed-integer formulation with a master problem (*Schedule Recovery Problem*) controlling three sub-problems (*Aircraft Recovery Model*, *Crew Recovery Model* and *Passenger Flow Model*). One of the limitation is the consideration of only cockpit crews.

(Bratu and Barnhart, 2006) proposed an integrated approach, wisely considering only stand-by and reserve crew (no optimization of the disrupted crews). Two models were presented both based on time-based space network representation. One is minimizing the sum of operational costs and disrupted passengers (*Disrupted Passenger Metric*), the other is minimizing the sum of passenger costs of delay and operational costs (*Passenger Delay Metric*). One year later, the DESCARTE project (Decision Support for integrated Crew and AiRcraft rEcovery), funded by the European Union through SESAR (Single European Sky ATM Research) and with British Airways participation, developed two integrated approaches called *Integrated Sequential Recovery* and *Tailored Integrated Recovery* to support operations under disruption, considering the three main pillars aircraft, passengers, and crews. Modelling the network through flight-arcs, the main contribution was to propose a first approach for multi-resources optimization during disruption (Kohl *et al.*, 2007). The crew sub-problem was solved through

column-generation and the passengers sub-problem was formulated as a multi-commodity flow problem.

(Castro, 2013) outlined in his PhD thesis an integrated approach in several steps based on a multi-agent system. Modelling first the crew assignment problem (Castro and Oliveira, 2007), several publications extended the resolution concept to the passengers problems (Castro and Oliveira, 2009) until a complete integrated method. The developments were followed by TAP airline. (Petersen *et al.*, 2012) modeled their Bender's decomposition approach on the one proposed by (Letovsky, 1997), although presenting a four-step recovery: first a schedule repair step (delay, cancel, divert) then an aircraft assignment step, followed by a crew assignment to the aircraft rotations and finally a passengers recovery step.

(Zhu *et al.*, 2016) presented a sample-based algorithm first solving the flight recovery with aircraft assignment, and then the crew and passengers problem with relaxed constraints to find feasible solutions, for which a lower and upper bound is estimated for large-scale problems. (Arıkan *et al.*, 2017) formulated the integrated problem as a flight network representation and added the speed control of aircraft as a conic quadratic mixed-integer programming formulation. To keep an acceptable computation time for live operational problems, the speed control, the passenger delay costs are pre-processed. (Heger, 2018) illustrated an integrated approach applied to the Lufthansa airlines in Frankfurt and Munich and implemented in their OCC system. However, the passengers solver is quite basic due to lack of data (only Lufthansa operated flights are proposed for rebooking options). (Ogunsina *et al.*, 2019) exploited an automated learning approach based on multi-agent systems, in which an agent uses a multidimensional Markov chain model to evaluate the disruption possible propagation. This agent could learn from the human decision on the solutions that he proposed in the past and where chosen.

Table 4: Overview of the literature review for the integrated recovery.

Scientific Article	Method / Contribution	Objective	Performances / Problem Size
(Lettovsky, 1997)	MIP formulation with master problem (schedule) controlling 3 sub-problems (aircraft, crew and passenger). Bender's decomposition method.	Minimize operational costs	-
(Bratu and Barnhart, 2006)	Two time-based space network representation. Only standby and crew reserve.	Reduce Passengers costs (delayed and disrupted passengers).	Applied to an airline with 302 aircraft 83,869 passengers (on several days, ~50% with connection), 9,925 different passenger itineraries per day; Instances of recovery are not detailed.
(Kohl <i>et al.</i> , 2007)	Network modelled through flight arcs, with multi-resources optimization. Local search for the network, column-generation for the crews, multi-commodity flow problem for the passengers.	Maximise revenue for the flights flown minus the costs of delays and cancellations.	No real test of the integrated system.
(Petersen <i>et al.</i> , 2012)	First repair the schedule, then the aircraft assignment, then the crew assignment and finally the passengers' itineraries.	Minimize operational costs	Applied to an airline with 800 flights per day; Disruptions instances impacting from 27% to 100% of the flights. No mention of passengers numbers nor crews numbers.
(Zhu <i>et al.</i> , 2016)	Sample-based algorithm solving flight recover and aircraft assignment. Crew and passengers problems: estimation of a lower and upper bound with relaxed constraints.	Minimize operational costs	47 flights operated by 9 aircraft. 13 crews, 7,797 passengers on 82 itineraries.
(Heger, 2018)	MIP for integrated approach, passengers' solver rebooking only on Lufthansa flights.	Minimize operational costs	47 aircraft with 194 flights and 20,600 passengers. 31 flights in the disruption window.
(Ogunsina <i>et al.</i> , 2019)	Automated learning approach based on multi-agent systems.	-	-

This literature review, summarized in Table 4, shows that integrated recovery is NP-hard problem was tackled by a few research and development. One must note that to propose an integrated optimization, some concessions must be done in regards with the amount and details of the rules, constraints and data that can be considered. A full recovery system focusing only on aircraft, passengers or crews enables a deep knowledge and modelling of most important hard and soft constraints specific to the airlines. Moreover, each airline has different set of rules, which necessitate a refinement of data and constraints for each potential new implementation.

While the aircraft problem might be tackled in a same way for all the airlines of a group, the passenger and crew problems are intrinsically linked with the airline business and history. A common definition of constraints and rules for these problems is difficult for the passenger problem, and nowadays impossible for the crew problem. Finally, the set of rules and constraints are constantly evolving, necessitating a permanent team to update all necessary elements in the optimizer system, especially for the crews, as the rules can change at each cockpit or cabin crew negotiations round, as well as at each update of EASA rules (in Europe). Therefore, integrated recovery is a wise combination of data combined with the right set of rules, and a smart algorithm choice and development to enable meaningful solutions to support the operational teams during disruptions.

## 2.5. Multi-Airlines Recovery

As explained in section 1.6 and outlined through the literature review above, one airline's operations optimization is already quite challenging. Several researchers tackled the multi-fleet recovery problem from one airline. Few researchers tackled the problem for multi-hubs operations optimization. (Arıkan *et al.*, 2016) proposed an approach optimizing the airline's operations with up to 4 hubs. However, only one OCC is steering the operations and no hub has its own autonomy. This is a major difference to the concept that is presented in this thesis, which is a multi-airline operations optimization. Having different OCC deciding together leads to multi-stakeholders decision-making problems, optimization objective to define according to all airlines, and a method to ensure that no airline is losing systematically from a group decision. From the best of our knowledge, no publication proposed multi-airlines recovery strategies nor methods, the integrated recovery problem for one airline being challenging enough. It seems that the collaboration during a disruption impacting different airlines is not well known as a scientific problem or that the complexity of one airline operations recovery is sufficiently complex to tackle multiple airlines recovery.

The only multi-airline thoughts in the ATM research exist with slot swapping among airlines (Delgado *et al.*, 2021; Schuetz, Lorünser, *et al.*, 2022). However, guaranteeing equity among the different stakeholders is a challenge that has not been sufficiently tackled today to enable these concepts to be implemented.

## 2.6. Chapter Conclusion

As shown by the state-of-the-art review presented in this chapter, the different recovery problems as a stand-alone problem are challenging. Their complexities increase with the data-driven strategies and the growing cooperation's possibilities such as airlines alliances. Semi-integrated (crew & aircraft and passengers & aircraft) recovery problems propose more realistic and blended-in solutions, while integrated solutions tackling the three recovery problems together must rely on a wise simplification of each sub-problem to enable reasonable computing time and feasible solutions. Other research fields are having similar problems, such as the train logistics that can be similar to an aircraft and crew recovery problem. Both fields (train and air transportation) regularly share their achievements, organizations, and visit their operations centers to get inspired by the methods and procedures of each other. The literature review presented in this chapter however targeted the air transportation to highlight the



achievements made these last decades, on which one can build the future research, as well as outline and identify the unsolved challenges.

Research on multiple airlines operations recovery is existing only as a multi-hub airline problem in the current scientific literature. The main difference is that in a multi-hub airline problem, one OCC takes the decision for all aircraft, flights, passengers, and crews from the different hubs. While in a multi-airline problem, several OCC, belonging to several airlines are taking decision for their own aircraft, flights, passengers, and crews. This decision can be defined together and discussed, but each OCC is responsible for its own operations. Therefore, a multi-airline operations optimization is challenging.

From the best knowledge of the author, this has not been tackled up to now and would require even wiser choice of complexity level for each sub-problem optimization. Multiple airlines optimization means different data available, rules, objectives, and challenges. A collaborative approach would bring in additional challenges such as the right definition of a group optimal solution as well as the human sensitivity in a group decision-making. Many airlines' groups exist today, principally to fight concurrence of other airlines and offer a wider network to the passengers (see section 1.6). A collaborative approach for these airlines to help each other during disruption appears to be an interesting research field for applied and industrial research, and for which nothing has been proposed.

Airlines operations remains a particularly challenging field, in which operations research played and continues to play an important role. No consensus on given optimization methods is reached, some are simply recommended or used because of their demonstrated efficiency or good results in previous research. Due to the increasing problem size through the data and the complexity of the operations, more accurate and sophisticated constraints must be considered to ensure a realistic model of the operations. More and more optimization methods originating from the OR community are nowadays supporting the daily operational teams in their tasks, and most of the airlines understand the need for data-driven operations. Some of them have even been investing in partnerships with OR company, such as KLM with Boston Consulting<sup>8</sup> or Lufthansa Group – with SWISS as a pioneer – with Google OR. The dynamicity of the daily operations and the increasing complexity of all partners' resources and needs (Airspace

---

<sup>8</sup> [KLM & BCG Extend Partnership for Digital Airline Operations](#)

## Chapter 2 - Literature Review on Airlines Operations Optimization

Navigation System Providers – ANPS –, Airport, EUROCONTROL, etc.) foster the need for further research into optimizing the airlines operations.

As explained in section 1.6, the current coordination consists in communicating the flights chosen for cancellations by each OCC within the group, and agreeing on a time to cancel, to avoid multiple rebooking of passengers on flights meant to be cancelled a few minutes after.

The goal of this thesis is not to consider more complexity or have faster computing time than other research methods presented in this chapter. It is to propose an optimization for a group of airlines willing to collaborate. Several airlines collaborating for the optimization of their joint operations means that a fair and wise definition of the constraints and rules to consider must result of a group discussion and alignment, while sovereignty of the airlines must be always granted. Aircraft recovery problem can be handled efficiently through different optimization methods if the constraints are carefully and wisely designed. Passengers recovery can be integrated with it, thanks to the generic and efficient proposition from (Acuna-Agost *et al.*, 2015). However, crew recovery is so intrinsically linked with each airline's set of rules and constraints, that a group optimization of crews seems nowadays impossible or inefficient. Thus, this first group optimization will propose a group aligned evaluation of the solutions on the crews rather than an optimization.

Chapter 3 will build on the industrial context explained in Chapter 1 and the literature review from this chapter to propose a high-level approach for a multi-airline optimization and address the main challenges.

### 3. Problematic, Scientific Challenges and Methodology Structure

As pointed out in Chapter 1, the financial impact of major disruption for airlines can be significant. Selling a ticket to a passenger is a contract, that the airline will fly the passengers from A to B within a given timeframe. The airlines thus must find an alternative for the passengers in case of disruption, even if it is caused by external factors such as weather or industrial actions from air traffic controllers. On another hand, political and societal pressure is arising with the Flightpath and European Union goals until 2050 (European Commission, Directorate General for Research and Innovation and Directorate General for Mobility and Transport, 2011), in particular for the environmental impact (zero-net carbon aviation in 2050) and for the European mobility (4 hours door to door planned for European passengers from any European place to any European place). Even during major disruptions, these goals are still enforced, and the airlines must find solutions to meet them with the local and European partners.

Operational disruption is a challenge to recover, be it from the aircraft, the crew or the passenger's perspective. Therefore, the operations research community is quite active on these topics. Multiple research activities were presented in chapter 2. The main objective of this thesis is to investigate if a multi-airline optimization is feasible, would be beneficial for all actors, and to propose a methodology for optimizing while granting the users acceptance and trust in the system. Figure 4 illustrates the macro-structure of the resolution steps to achieve a group optimization with several airlines.

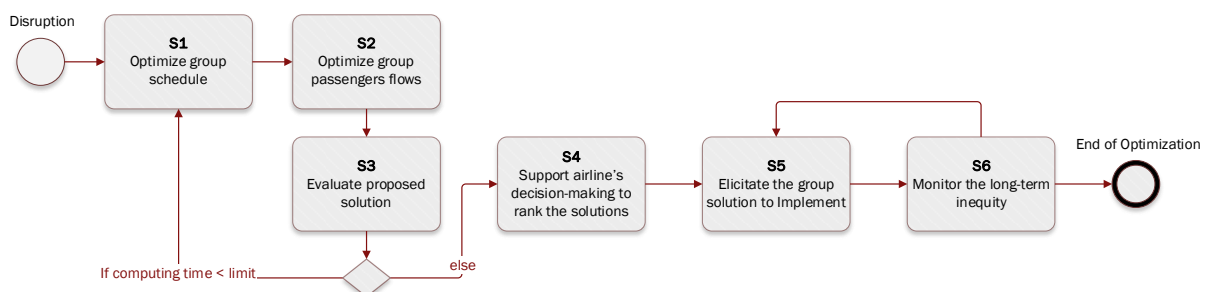

Figure 4: High-level PhD overview of resolution step.

### **3.1. Conclusions from the Industrial Context and Literature Review**

#### ***3.1.1. Summary on the Aircraft and Flight Recovery Problem***

Chapter 2 enabled to highlight some conclusions. First, no perfect problem solving nor optimization method currently exists for the airline's operations optimization problem. Even on the sub-problems (flight scheduling, aircraft, crews, and passengers), no consensus on a given method is reached. However, most of the researchers start with first optimizing the aircraft and flight assignment before checking the impact on – and for some optimizing – the other problems. This is a good approach as the passenger and crew assignments depend on when the flights are operated. It also depends on the aircraft type assigned to the flight, as different types of crew qualifications might be needed, and a different number of passengers can be accommodated.

However, the policies for aircraft swaps or equipment changes (aircraft swaps inter fleet) are different from one airline to the other. In a multi-airline optimization problem, a SWISS aircraft cannot be assigned to a Lufthansa flight number, as this is legally not negotiated nor acted. Some airlines can take over some flights from another airline and operate it with their own resources (see chapter 1). This is called wet lease. Wet leases are pre-defined contracts that are negotiated regularly and might be costly to the airline purchasing it. Therefore, in a multi-airline problem, it must be guaranteed that no aircraft swaps are allowed between two different airlines. This is a legal limitation that should remain for the couple of years to come, and that must be considered in our group optimization approach.

Therefore, we propose to limit, in a first step, the aircraft recovery problem to a flight-scheduling problem. The allowed actions for a group optimization of the flights will be the cancelation or the re-timing of the departure time (before or after the scheduled one). The scientific challenge lies in the elaboration of an efficient optimization method enabling an identification of the flights to cancel and delay to obtain the best operational performances for the group. This corresponds to step S1 on Figure 4.

#### ***3.1.2. Summary on the Passenger and Crew Problems***

The passenger problem is relatively standard: all passengers have a reservation number, a booking class, a sequence of flights to go from their origin to their destination. The difference between the airlines lies in the different status that a passenger can declare. Some have a fidelity program and can reach a high level of importance as they are regularly flying with the same

airlines group. Some can travel as part of a group (such as reservations organized by travel agencies). Some can require assistance in case of limited mobility. Some can be crewmembers flying back to their home base as passengers as they reached their duty time limits. Some can have a low priority of travel, such as the airline's employees flying with discounted tickets.

Finding the right amount and level of statuses that should be considered in an airlines group optimization is to be defined and carefully aligned with experts before any modeling and optimization. Thanks to this standardization of the passenger problem, a group approach is possible without losing too many information and reducing the solution quality. One of the methods presented in the literature study should be applicable, as the problem definition remains similar to the literature ones.

The scientific challenges lie in the optimization method to be efficient enough to enable an imbricated optimization of the passengers for each new planning of flights proposed by the first optimization. It must be able to handle large passenger numbers with carefully defined group-aligned statuses and multiple itineraries options on all the flights of the Lufthansa Group and their codeshare airlines. This corresponds to step S2 on Figure 4.

By contrast, the crew problem is highly different from one airline to the other. The same standard high-level constraints are aligned, such as respecting the duty time limits from the airline rules and the international rules (such as the EASA ones). However, these limits are calculated through very complex set of constraints, rules, and special agreements. Any change in the flights assigned to the crew, the length of duty or the aircraft type (for cabin crew) to be flown can have consequences on the duty time limits. Thus, any change in the crew planning must trigger recalculations to verify that the new plan is legally valid. As shown in section 2.3, many research articles simplify the crew rules and constraints, and each requires extensive work for modelling the right rules and optimizing accordingly. Trying to propose aligned rules of calculations for the duty time limits among all different airlines crews would result in wrong results, not representing the reality, and hampering the quality of the group solutions.

Therefore, the crew problem for multi-airline operations approach will remain simple. The indicators to evaluate whether a solution is good or not for the group can be aligned within the airlines, and carefully defined with experts. No proper optimization will be proposed for the crew problem, rather an aligned and accepted assessment of the impact of a solution on the crews from the different airlines participating. One mitigation that can be proposed is to enable

the experts to indicate if the operational situation at their hubs is having specific crew constraints, such as a very low number of crew reserve, or many crew operating their last flights with only small buffer with their duty time limits.

### ***3.1.3. Optimization Structure Proposition***

From the last two summaries, one can conclude that a semi-integrated approach for a group of airlines seems to be right. Starting with the aircraft recovery (limited to the assignment of delay and cancellation on the flights operated by the group of airlines), a new planning of flight can be proposed, on which the passengers of all airlines' flights disrupted can be optimized to find better alternatives. The crew impact for each airline will be assessed, but no crew optimization will take place. Indicators for the solution assessment must be carefully designed with the operational experts of the different airlines.

The assessment of each solution proposed by the new planning and the new passenger assignment is primordial and is a scientific challenge. It must represent a just balance between the different aspects of an evaluation: the operational impact of the flights delayed and cancelled, the impact on the passengers that might have costly or even no rebooking options on the same day, and the impact on the crew. In a group assessment, the relation of the different aspects must be carefully designed and approved by all experts. Better is even to involve the users of all airlines to define clear and transparent indicators for the solution assessment as well as their relationships with each other. This is a key point for fostering the user endorsement of a group optimization. This corresponds to step S3 on Figure 4.

A multi-objective approach, as proposed by some articles presented in chapter 2, is considering all objectives having the same importance and optimize on each of them to find the Pareto front. In some cases, authors reported that a hybrid method were leading to far better results, with some “guide” for the solutions, similar to a multi-criteria approach. However, in a group optimization, a pre-requisite is a good definition of the group objectives as well as a clear relationship or weight relation between each criterion. This common vision must be agreed upon on, and the optimizer must follow this group vision to ensure that the solutions proposed are in line with the group strategy. Therefore, we propose to use a multi-criteria decision making method to provide a group macro-indicator and to enable a fair aggregated view of the overall group performances in respect to the group pre-defined vision with all stakeholders involved and an efficient solution evaluation.

### ***3.1.4. Group Acceptance and Trust in a Multi-Airlines Approach***

As the optimizer has a limited computing time and that the instances might be quite large, 2 to 5 minutes might not be sufficient to converge to one optimal solution. Thus, the different airlines must reach a consensus on the solution to implement. A group solution must remain clear and transparent in the evaluation phase, and the elicitation of a solution among other good solutions for the group must be a cooperative and active process. Each airlines' expert should be able to express their preferences among the proposed solutions. A scientific challenge is to propose a methodology combining and consolidating the preferences of each airline, so that the solution to implement results from a group decision in which all participants can collaborate. This corresponds to S5 on Figure 4.

Assessing several complex solutions in a limited time can be particularly challenging for human-brain.

Thus, a decision-support mechanism can be defined to help the experts in their choices and decisions. This must however remain a clear and understandable process and an expert should always be able to adapt it if not agreeing with the proposed outputs. This corresponds to S4 on Figure 4.

The airlines must trust in the system for choosing the best group solution while reducing the inequity in terms of impact.

Granting equity on each optimization would limit the search space and the flexibility of the optimizer to seek for group optimal solutions. It is thus not wished to grant the equity at each of the optimization. The last scientific challenge lies in proposing a mechanism to calculate the equity of the airlines on a long-term, so that a monitoring can be transparently proposed, and that any misbalance can be addressed clearly after a few months of utilization. This corresponds to S6 on Figure 4.

## **3.2. Thesis Research Questions and Methodology Structure**

The hypothesis presented in this thesis is straightforward. "Together we are stronger" is the suggestion that airlines' group cooperating during major disruption could result in reduced disruption impact and better passenger solutions than each airline optimizing its own operations.

Very few optimizations reducing the disruption impact on multi-hubs airline exists today and are only targeting multi-hubs steered by one unique OCC. This thesis aims at proposing a first process for a group optimization, with the necessary trade-off in data granularity. Indeed, without quantum computers nor new generation of optimizers, the current technology cannot offer a full optimization considering all data from several airlines. These are the first research questions of this thesis:

**Research Question 1:** *propose a definition of the trade-off in all the data and constraints that a group optimization can consider, while keeping the computation time within the given limits.*

**Research Question 2:** *Define an optimization methodology able to propose group optimal solutions.*

*This will be presented in chapters 4 (mathematical formulation of the problem), 8 (optimization of the flight schedule) and 9 (optimization of the passengers flows).*

Optimizing operations from different airlines leads to numerous indicators that can be highly heterogeneous as the vision and sensitivity of each airline are different. These results in conflictive objectives function for the core optimizer and necessitate a group common approach on the indicators definition and importance. This thesis' third research question is:

**Research Question 3:** *propose a method for a group decision-making and definitions of the indicators, respecting the airlines specificities and main business objectives to enable a group optimization. This will be presented in chapter 5.*

If one imagines a group solution, with a cancellation of a given percent of flights, not per airline but on the overall group airlines affected by the major disruption, an optimized solution might propose that one airline takes over much more cancellations than the others, if these flights are less critical for the group. This however leads to serious political, financial, and human questions, in case of advanced coordination. A group decision sometimes must be unfair to reach the group optimum, and granting a strict equity each time would results in far less optimal solutions. The decision process therefore must involve representatives of each OCCs (multi-stakeholders' decision) and it must be proven that the entire group is winning from temporary inequity and that the global equity among airlines is ensured on the long-term. This leads to the fourth and fifth research questions aimed by this thesis:



**Research Questions 4 & 5:** propose a process enabling:

- each airline to express its assessment of the proposed solutions,
- a group consensus to be reached on the solution to implement,

while guaranteeing the trust and acceptance of the group optimization model. This will be presented in chapter 6.

**Research Question 6:** propose a definition of the long-term global equity among all airlines participating to the group optimization and demonstrate that this equity can be reached under given assumptions through dedicated mechanism. This will be presented in chapter 7.

Thus, this thesis aims at confirming the hypothesis that a group optimization under major disruption is truly bringing benefits to all airlines, that all airlines accept the optimization and decision processes and that equity is ensured on the long-term for all participating airlines. To this end, a method, adapted to industrial cases, is established, addressing the four main challenges identified above.

Finally, the proposed methodologies and the corresponding Minimum Viable Product (MVP) developed will be presented on industrial cases. This will be presented in Chapter 10.

---

# Mathematical Formulation

---

## 4. Mathematical Formulation of the Group Airlines Optimization

This chapter aims at presenting the mathematical formulation on which our approach is based. It enables to highlight the simplification proposed to reduce the complexity of the problem, as well as underline the important relations between the different input data, decision variables, linked variables, constraints and expected indicators. As we are treating a multi-hubs airlines operational problem, some constraints must be relaxed, and some hypothesis simplified to enable a clear and efficient optimization (see section 3.1). The relations between all the inputs data are summarized and illustrated in the Entity-Relation (ER) model presented in Figure 5

One should note that, for simplification reasons, the ER model is representing the data relations only for a disruption happening on a same day, and not for a disruption lasting for several days. This is enabling a cleaner view of the data relationships. Moreover, from our mathematical model, the aircraft cannot be assigned to delays that would block them in an outstation due to curfew time at the hub airport for arrival or at the outstation for departure, nor have only one leg of the rotation cancelled (see section 4.4). Therefore, modelling a 3-days-long disruption could be split in three sub-problems, the first one tackling the first day of disruption and feeding the following ones.

All airlines belong to a group of airlines and are identified by an IATA Code (e.g., LX for SWISS, LH for Lufthansa, etc.). Each airline operates from an airport identified by its IATA code (e.g., ZRH for Zurich, MUC for Munich, etc.). The disruptions considered are identified by a specific key and can impact at least and at most one airport. From the *Disruption Beginning Time* and *Disruption Ending Time* it is trivial to retrieve the list of flights operated from and to the disrupted airport within the time window defined by the disruption and operated by the considered airlines. For each of these retrieved flights, the passengers booked on it, their

itineraries, and specificities (such as booking class, statuses, etc.), the crews operating these flights and their respective schedules as well as the aircraft operating these flights and their respective flights planned on its tail can be retrieved. This set the scene for the inputs needed for the mathematical formulation.

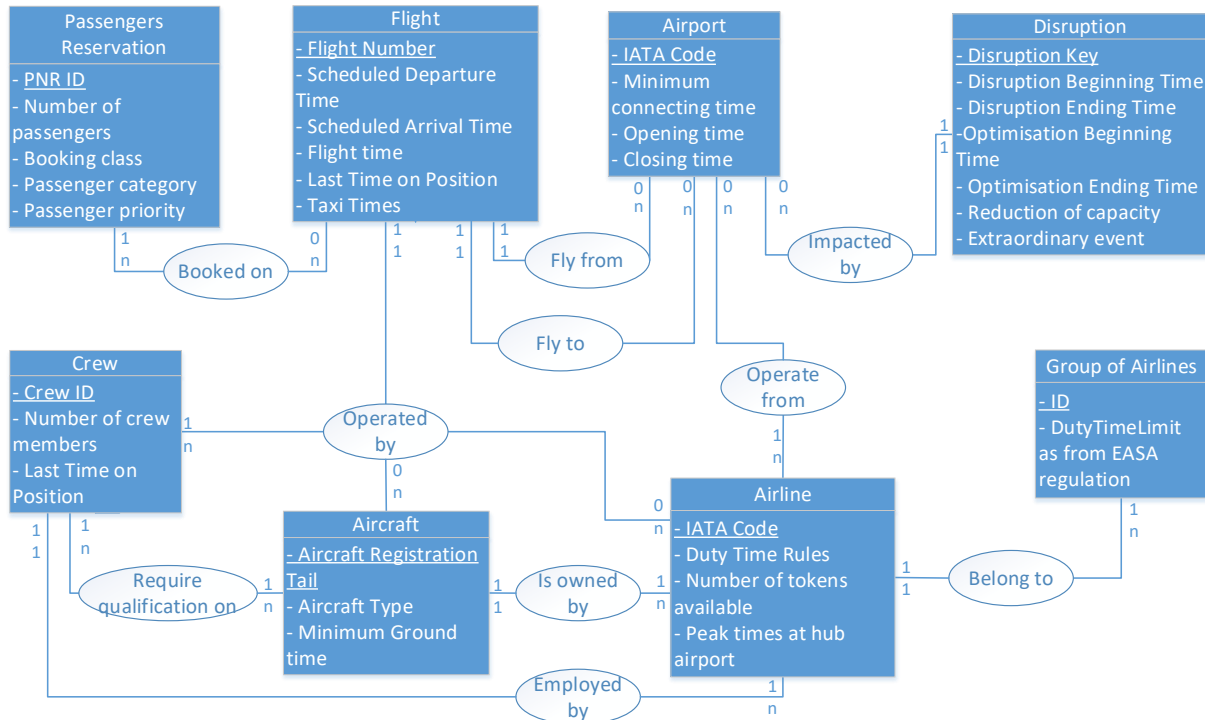

Figure 5: Entity-Relation Model of the inputs data of the problem.

For an easier comprehension of the following part, the reader might refer to the notation table in Appendix A. The entity Airport is first described in section 4.1.1, followed by the description of the disruption in section 4.1.2. As explained below, a disruption concerns one airport at least and at most, while an airport can be subject to no or multiple disruptions. An airport can be the hub of one or several airlines, but can be also an outstation, which means that no airline are from there as a hub. The airline entity is described in section 4.1.4. It must be noted that in our problem, only airlines belonging to a group of airlines are considered. Each airline operate one or multiple aircraft that are owned or rented by the airline. An aircraft can be owned only by one airline. The aircraft entity is described in section 4.1.3. Several aircraft type require several qualifications from the crew operating it. Some aircraft types have quite similar type ratings, such as the A330 and A340, which leads to pilots able to fly different aircraft types. However, for other aircraft type such as the B777 at SWISS, the pilots can only operate this type of aircraft. For the cabin crew, multiple aircraft can be operated. The crew entity is described in

section 4.1.10. Each aircraft can operate zero to multiple flights while a flight must be operated by an aircraft. The flight entity is presented in section 4.1.6. More specifically, the flight disrupted by the disruption are presented in section 4.1.7. Finally, passengers are booked on the flights through a reservation, and this passenger' reservation entity is described in sections 4.1.5, 4.1.8 and 4.1.9.

To facilitate the reader comprehension, the mathematics formulation of the problem follows given basic rules:

- All discrete sets have a specific name (such as *Airport*) or are noted thanks to braces (e.g.,  $Slot = \{5,10, \dots,1440\}$ ),
- For entry data and associated data: indices are used to signal if the data is referring to the initial situation (e.g.,  $Dep_{Ini}$ ) or the considered solution (e.g.,  $Dep_{Rel}$ ),
- Floor and ceiling functions are respectively written  $\lfloor x \rfloor$  and  $\lceil x \rceil$ .

#### 4.1. Input Data

We first define some general sets:

*AirlinesGroup*      The set of airlines belonging to the group considered, for which an element is noted  $i$ .

*Crew*      Set of all crews operating a flight caught in the optimization definition.

*Schedule*      Set of flights operated by the airlines belonging to the considered group, of which an element is noted  $k$ .

$T$       Set of times in minutes in a day, in UTC.

$D$       Set of durations, in minutes.

##### 4.1.1. Airport Data

Each airport has specific characteristics.

*OpeningTime ClosingTime*      An opening time and a closing time, corresponding to the night ban curfew of flights during the night (if a night ban curfew is enforced at the airport). The opening and closing times might depend on the airline.

*MinConnTime*      A minimum connecting time corresponding to the legal minimum time that a passenger must have to connect between two flights in the airport (depends on the airport structure between the gates).

We thus define:

*Airport*      Set of officially recognized airport by IATA and ICAO.

$\forall ABC \in Airport, \forall i \in AirlinesGroup,$

- *OpeningTime*:  $Airport \times AirlinesGroup \rightarrow T,$
- *ClosingTime*:  $Airport \times AirlinesGroup \rightarrow T,$
- *MinConnTime*:  $Airport \times AirlinesGroup \rightarrow D,$

#### 4.1.2. *Disruption Data*

A disruption is defined by:

*XYZ*      A disrupted airport ,

*RedCap*      A requested reduction of capacity in percent,

The user must also provide a disruption window and (same or larger) optimization window to give more flexibility to the system and enable to find better solutions, with:

*TdisruptionBegin(XYZ)*      The beginning time of the disruption,

*TdisruptionEnd(XYZ)*      The ending time of the disruption,

*TOptiBegin(XYZ)*      The beginning time of the optimization,

*TOptiEnd(XYZ)*      The ending time of the optimization,

In general, the following information are defined for the comprehension of the problem:

*Aircraft*      Set of aircraft belonging to the fleet of the considered airlines group.

*Slot* = {5,10, ...,1440}      Set of departure and arrival slots, as in Europe the times slots are reported every 5 min.

*ExtraordinaryEvent* As from the European Definition “if the disruption is caused by extraordinary circumstances which could not have been avoided even if all reasonable measures had been taken” (European Parliament, 2004). This information releases (or not) the compulsory financial compensation to the passengers in case of important delays, for all flights from or to Europe, as from the EUC261 law

Each airline  $i$  is having:

$Schedule_i$  Set of flights scheduled by an airline  $i$ ,

$A_{Opti}$  Set of aircraft operating the flights from  $Schedule_i$  and available for the optimization.

We thus define:

$\forall i \in AirlinesGroup, XYZ \in Airport,$

- $Schedule_i \subseteq Schedule,$
- $A_{Opti} \subseteq Aircraft,$
- $TdisruptionBegin: Airport \rightarrow T,$  with:

$TdisruptionBegin(XYZ) \in \left[ \min_i(OpeningTime(XYZ, i)), \max_i(ClosingTime(XYZ, i)) \right],$

- $TdisruptionEnd: Airport \rightarrow T,$  with:

$TdisruptionEnd(XYZ) \in \left[ \min_i(OpeningTime(XYZ, i)), \max_i(ClosingTime(XYZ, i)) \right],$

- $TOptiBegin: Airport \rightarrow T,$  with:

$TOptiBegin(XYZ) \in \left[ \min_i(OpeningTime(XYZ, i)), TdisruptionBegin(XYZ) \right],$

- $TOptiEnd: Airport \rightarrow T,$  with:

$TOptiEnd(XYZ) \in \left[ TdisruptionEnd(XYZ), \max_i(ClosingTime(XYZ, i)) \right],$

- $RedCap \in ]0,1],$
- $ExtraordinaryEvent \in \{0,1\}.$

### 4.1.3. Aircraft Data

Each aircraft, indexed by  $a$ , belongs to a specific airline  $i$ . The airline  $i$  might have a fleet comprising different aircraft type:

$A_{Opti,i}$  Set of all aircraft available for the optimization and belonging to  $i$ ,

$A_{Opti,i}^m$  Set of aircraft type  $m$  (e.g.: A220-100, B777) belonging to airline  $i$  and available for the optimization (in the context of the given disruption),

$A_{Opti}^m$  Subset of aircraft of type  $m$  available for the optimization, irrespective of the airline belonging it,

*GroundTime* Function providing the given minimum ground time in minutes between two flights operated by a specific aircraft type (for turnaround processes such as de-boarding, fueling, cleaning, etc.),

*TailOwnership* Function providing the information to which airline an aircraft belongs to,

*TailProperty* Function providing the information about the aircraft type.

We thus define:

*ACType* Set of aircraft types.

$\forall a \in Aircraft, \forall m \in ACType, \forall i \in AirlinesGroup,$

- $A_{Opti,i} \subseteq A_{Opti},$
- $A_{Opti,i}^m \subseteq A_{Opti,i},$
- $A_{Opti}^m = \cup_i A_{Opti,i}^m,$
- $TailOwnership: Aircraft \rightarrow AirlinesGroup,$
- $TailProperty: Aircraft \rightarrow ACType,$
- $GroundTime: ACType \times AirlinesGroup \rightarrow D$
- $\forall a \in Aircraft, \exists! m \in ACType,$

$$TailProperty(a) = m \quad \text{Eq. 1}$$

- $\forall i \in AirlinesGroup, \forall m \in ACType,$

$$A_{Opti,i} = \{a \in A_{Opti} \mid TailOwnership(a) = i\} \quad \text{Eq. 2}$$

$$A_{Opti,i}^m = \{a \in A_{Opti,i} \mid TailProperty(a) = m\} \quad \text{Eq. 3}$$

Concerning the spare aircraft, also called “reserve”,

*TAvailBegin* and *TAvailEnd* Functions providing the beginning and ending time of the aircraft availability with no flights nor maintenance event planned during this time,

*DurationThresholdReserveF* Function providing the minimum amount of time (in minutes) during which an aircraft of type  $m$  should stay on-ground with no flights nor maintenance event allocated, to be considered as a reserve (3 hours in our problem).

*TailReserve* Function enabling to quantify if an aircraft is available as a reserve.

We thus define:

- $TAvailBegin: A_{Opti} \rightarrow T,$
- $TAvailEnd: A_{Opti} \rightarrow T,$
- $DurationThresholdReserveF: ACType \rightarrow D,$
- $TailReserve: Aircraft \rightarrow \mathbb{N},$

$$\forall a \in Aircraft, \forall m \in ACType \text{ such as } TailProperty(a) = m,$$

$$TailReserve(a) = \left\lfloor \frac{TAvailEnd(a) - TAvailBegin(a)}{DurationThresholdReserveF(m)} \right\rfloor \quad \text{Eq. 4}$$

#### 4.1.4. Considered Airlines Group Data

*HUB(i)* The main hub airport from which an airline  $i$  operates, with its opening and closing times (as defined in part 4.1.1).



*PeakTime<sub>i</sub>* Set of peak traffic time of *HUB(i)*, from which an element is noted *e*. A peak hour is defined by a beginning and ending time during which numerous arrivals and departures of flights are planned and the user prefer to avoid adding an additional departure arrival by delaying a flight planned initially before the peak time. If two airlines operate from the same hub airport, each one defines its own peak times, as the perception might be different, and the two airlines might operate its flights at different time of the day.

*PeakTimeF* Function providing the peak traffic times begin and end.

We thus define:

$\forall i \in \text{AirlinesGroup},$

- $HUB: \text{AirlinesGroup} \rightarrow \text{Airport},$
- $PeakTime_i \subseteq \mathcal{P}(\text{Slot} \times \text{Slot}),$
- $PeakTimeF: PeakTime_i \rightarrow \text{Slot} \times \text{Slot},$  with:

$$\forall (S_1, S_2) \in PeakTime_i, PeakTimeF((S_1, S_2)) = [S_1, S_2] \quad \text{Eq. 5}$$

which corresponds to all slots belonging to the time interval between peak time begin  $S_1$  and the peak time end  $S_2$ .

#### 4.1.5. Passengers Data

To properly define later the passenger problem, the following set must be introduced (see section 3.1.2 for a high -level description):

*PaxType* The set of classes on which a passenger can book a seat (First, Business, Premium Economy, and Economy), from which an element is noted *pt*,

*PaxPrio* The set of different priorities that a passenger could have, such as PCARE passengers (like VIP, Miles & More fidelity statuses: HON circle members, Senators – SEN – or Frequent Fliers – FFP, etc.), the special passengers such as crew flying as a passenger to operate a flight at the destination airport – DHC – or PAD passengers (staff from an airline with booked tickets – R1 PAD status– or with standby tickets, flying only if a seat is available– R2 PAD status–, that have a lower priority in the rebooking process), from which an element is noted *pp*.

*PaxCategory* The set of categories, defined from the sets *PaxType* and *PaxPrio*, for convenience purposes in the indicators calculations and grouped as from experts' request, from which an element is noted *pc*.

We thus define:

- $PaxType = \{First, Business, Premium Economy, Economy\}$ ,
- $PaxPrio = \{VIP, HON, SEN, FFP, Standard, PADR1, PADR2, DHC\}$ ,

The Table 5 illustrate the concept:

Table 5: Matrix illustrating the passenger categories as from the *PaxType* (indexed by *pt*) and *PaxPrio* (indexed by *pp*)

PaxType (pt)	PaxPrio (pp)					Airline's Employees Priorities		
	VIP	HON	SEN	FFP	Standard	PADR1	PADR2	DHC
First	PC1	PC1	PC1	PC1	PC1	PC3	PC4	PC1
Business	PC1	PC1	PC2	PC2	PC2	PC3	PC4	PC2
Premium Eco	PC1	PC1	PC2	PC3	PC3	PC3	PC4	PC3
Eco	PC1	PC1	PC2	PC4	PC4	PC3	PC4	PC4

*PaxCategory* :  $\mathcal{P} (PaxType \times PaxPrio)$  with  $PaxCategory = \{PC1, PC2, PC3, PC4\}$

such that:

$$PC1 = \{(pt, pp) \mid (pt = First \wedge pp \notin \{PADR1, PADR2\}) \vee pp = VIP \vee pp = HON\} \quad \text{Eq. 6}$$

$$PC2 = \{(pt, pp) \mid (pt = Business \wedge pp \in \{DHC, FFP, Standard\}) \vee (pp = SEN \wedge pt \neq First)\} \quad \text{Eq. 7}$$

$$PC3 = \{(pt, pp) \mid (pt = Premium Economy \wedge pp \in \{DHC, FFP, Standard\}) \vee pp = PADR1\} \quad \text{Eq. 8}$$

$$PC4 = \{(pt, pp) \mid (pt = Economy \wedge pp \in \{DHC, FFP, Standard\}) \vee pp = PADR2\} \quad \text{Eq. 9}$$

#### 4.1.6. Flights Data

A flight is defined by:

$Dep_{Ini}$  and  $Arr_{Ini}$  Functions providing its departure and arrival times,

$DepAirport$  and  $ArrAirport$  Function providing its airport of departure and destination,

$NBPax_{Ini}$  Function providing the number of passengers initially booked on the flight per booking class (identified by  $pt$ ),

$FlightTime$  Function providing its flight time,

$TaxiInTime$  Function providing the taxi in time, which corresponds to the time between the push-back from the tarmac (if no push-back, as from the start of the rolling) and the take-off time,

$TaxiOutTime$  Function providing the taxi out, which corresponds to the period between the landing and the arrival at the tarmac,

$BlockTime$  Function providing the sum of the three precedent times,

$LTOT$  Function providing the Last Time Of Touchdown, which is the latest time at which the flight must arrive at gate before impacting the following operations through crew or aircraft rotations, or passenger connection,

$NextFlight$  Function providing the next flight operated on the same aircraft, which is enabling operational impact calculation of delay.

$Rotation$  Function providing the flights depending on each other: several flights are considered in a same rotation if they are operated by the same aircraft, and in the same sequence from the hub to the hub. Thus, a change of schedule on one of the flights could influence the other one.

**Side Note:** as from this part, the index  $Ini$  refers to the initial situation before the optimization and  $Rel$  refers to the considered solution proposed by the optimizer.

We thus define:

$\forall i \in AirlinesGroup, \forall k \in Schedule_i,$

- $Dep_{Ini}: Schedule_i \rightarrow Slot$

- $Arr_{Ini}: Schedule_i \rightarrow Slot$
- $DepAirport: Schedule_i \rightarrow Airport$
- $ArrAirport: Schedule_i \rightarrow Airport$
- $NBPax_{Ini}: Schedule_i \times PaxType \rightarrow \mathbb{N}^*$
- $Rotation: Schedule_i \rightarrow \wp(Schedule_i)$
- $FlightTime: Schedule_i \rightarrow D$
- $TaxiInTime: Schedule_i \rightarrow D$
- $TaxiOutTime: Schedule_i \rightarrow D$
- $BlockTime: Schedule_i \rightarrow D$
- $LTOT: Schedule_i \rightarrow Slot$
- $NextFlight: Schedule_i \rightarrow Schedule_i$

These respects (as illustrated in Figure 6):

$$\forall i \in AirlinesGroup, \forall k \in Schedule_i,$$

$$BlockTime(k) = FlightTime(k) + TaxiInTime(k) + TaxiOutTime(k) \quad Eq. 10$$

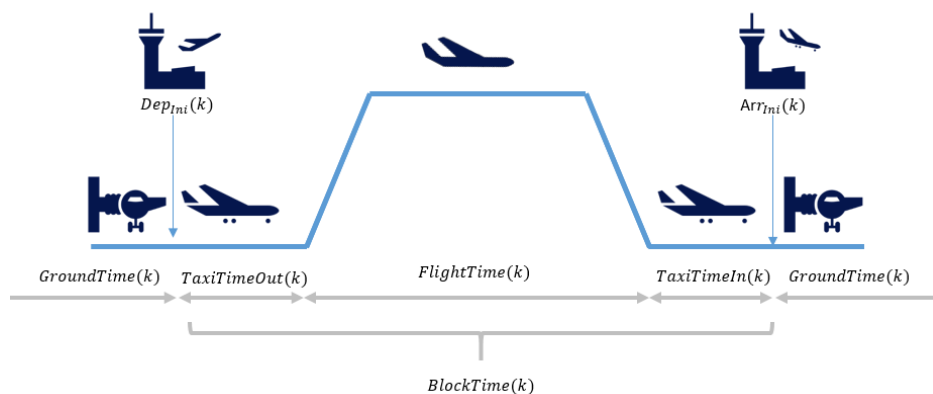

Figure 6: Operational Times Illustration.

#### 4.1.7. Data of the Planned Flights at the Disrupted Airport

Besides the standard information explained in the last part, a flight caught in the optimization period (flight disrupted) is also having the additional information. To clearly indicate if a flight

belongs to the optimization period, we note it  $k_{fp}$ . The specific information for these flights caught in the optimization period are:

$NBToken(k_{fp})$  The number of tokens allocated by an airline to prioritize certain flights that are important for any reason, which might not be recognized through the data (operational situation awareness),

$Aff_{Ini}^{Slot}(k_{fp})$  The initially planned departure slot of the flight,

$Aff_{Ini}^{AC}(k_{fp})$  The initially planned aircraft to operate the flight,

$Aff_{Ini}^{Crew}(k_{fp})$  The crew operating the flight,

$Flight^{NoCNL}$  The information that a flight cannot be cancelled: all flights in Europe must comply with the 80/20 airport slot rules, which means that a flight must be operated at least 80% on-time (+/- 15min around the planned slot time) during an operational season. If this rule is not observed, the airline loses its grandfather rights on the initial slot and another airline could take it over. Any flight delayed more than 15min or cancelled is not respecting this rule. Therefore, each airline monitors each flight number and issue a warning to its operational decision-makers in case a flight approaches the 80% limit of on-time performance. The reader should note that the European 80/20 airport rule is active even if the cancellations and delays are requested by the airport itself.

We thus define:

$E^{Opti}$  Set of the disrupted flights  $k_{fp}$  on the optimization time window.

$$E^{Opti} = \left\{ \begin{array}{l} k_{fp} \in Schedule \wedge \left( \begin{array}{l} Dep(k_{fp}) \in [TOptiBegin(XYZ), TOptiEnd(XYZ)] \\ \wedge DepAirport(k_{fp}) = XYZ \end{array} \right) \\ \vee \left( \begin{array}{l} Arr(k_{fp}) \in [TOptiBegin(XYZ), TOptiEnd(XYZ)] \\ \wedge ArrAirport(k_{fp}) = XYZ \end{array} \right) \end{array} \right\} \quad \text{Eq. 11}$$

$\forall k_{fp} \in E^{Opti},$

- $FlightPrio: E^{Opti} \rightarrow \{0,1\}$
- $E_i^{Prio} \subseteq E_i^{Opti}$

- $E_i^{Prio} = \{k_{fp} \in E_i^{Opti} | FlightPrio(k_{fp}) = 1\}$  Eq. 12
- $Flight^{NoCNL}: E^{Opti} \rightarrow \{0,1\}$
- $Aff_{Ini}^{Slot}: E^{Opti} \rightarrow Slot$
- $Aff_{Ini}^{AC}: E^{Opti} \rightarrow Aircraft$
- $Aff_{Ini}^{Crew}: E^{Opti} \rightarrow Crew$

For easier reading, we define the following function, providing the airline operating a flight:

$$\forall k_{fp} \in E^{Opti}, AirlineF: E^{Opti} \rightarrow AirlinesGroup$$

For the rest of the document, we define the following sets:

$E^{Incident}$  Set of flights scheduled during the disruption time window,

$E_i^{Opti}$  Set of the flights scheduled during the optimization time window and operated by the airline  $i$ .

$E^{Incident} \subseteq E^{Opti}$  , with:

$$E^{Incident} = \{k_{fp} \in E^{Opti} | Aff_{Ini}^{Slot}(k_{fp}) \in [TdisruptionBegin(XYZ), TdisruptionEnd(XYZ)]\}$$
 Eq. 13

$E_i^{Opti} \subseteq E^{Opti}$  , with

$$E_i^{Opti} = \{k_{fp} \in E^{Opti} | k_{fp} \in Schedule_i\}$$
 Eq. 14

#### 4.1.8. Passenger Reservations Data (within the Optimization Timeframe)

For the flights caught in the optimization, the following must be defined:

*Reservation* Set of reservation with one planned flight at least disrupted by the considered problem,

*PaxTypeF* Function providing the initial booking class of a reservation,

$PrioPaxF$	Function providing the initial priority of a reservation,
$PaxCategoryF$	Function providing the initial category of a reservation (as defined in 4.1.5),
$NBPax$	Function providing the number of passengers booked in a reservation,
$OrgAirport$	Function providing the origin airport of a reservation,
$DesAirport$	Function providing the destination airport of a reservation,
$Dist$	Function providing the distance in km between the two airports,
$OrgDepartureTime$	Function providing the original scheduled time of departure from the origin airport,
$DesArrivalTime$	Function providing the arrival time at the destination airport,
$Itinerary_{ini}$	Function providing the initial booked itinerary (sequence of flights booked to reach the destination from the origin airport).

We thus define:

$\forall i \in AirlinesGroup, \forall k \in Schedule_i, \forall s \in Reservation,$

- $NBPax: Reservation \rightarrow \mathbb{N}^*$
- $PaxTypeF: Reservation \rightarrow PaxType$
- $PrioPaxF: Reservation \rightarrow PaxPrio$
- $PaxCategoryF: Reservation \rightarrow PaxCategory$

With:

$\forall s \in Reservation,$

$$\exists! pc \in PaxCategory \text{ such as } PaxCategoryF(s) = b \quad \text{Eq. 15}$$

$$\exists! pt \in PaxType \text{ such as } PaxTypeF(s) = l \quad \text{Eq. 16}$$

- $OrgAirport: Reservation \rightarrow Airport$

- $DesAirport: Reservation \rightarrow Airport$
- $Dist: Reservation \rightarrow \mathbb{N}^*$
- $OrgDepartureTime: Reservation \rightarrow T$
- $DesArrivalTime: Reservation \rightarrow T$

#### 4.1.9. Passenger Itineraries Data (within the Disruption Timeframe)

To further deepen into the passenger data, each passenger departs from its origin airport and reach its destination airport through a so-called itinerary, which is composed by one or several flights.

Let us define:

$V \subseteq \mathcal{P}(Schedule)$  Set of all itineraries possible, between all pairs of origins and destinations of the passengers considered in the set *Reservation*,

$V_{Ini} \subseteq V$  Set of initially planned itineraries for the considered reservations in *Reservation*

An element of  $V$  is a possible itinerary noted  $v$  and is defined as:

$OrgIti$  Function providing the origin airport of an itinerary,

$DesIti$  Function providing the destination airport of an itinerary,

$NbFlights$  Function providing the number of flights in an itinerary,

$DepTimeIti$  Function providing the departure time of the first flight of the itinerary at the planned origin,

$ArrTimeIti$  Function providing the arrival time of the last flight of the itinerary at the planned destination,

$PaxTypeItiF$  Function providing the booking class that the passengers booked for the itinerary,

$NextFlightIti$  Function providing the next flight booked in the reservation,



$Aff_{Ini}^{Pax}$  Function providing the information about the itinerary initially booked for a reservation.

**Example:** from Zürich to Paris, one itinerary would be F1 (direct flight), another itinerary could be (F2, F3) with a connection in Munich, and a third itinerary could (F2, F5, F6) with connection in Munich and Vienne.

We thus define:  $\forall v \in V$ ,

- $v = \{(k_1, \dots, k_n) | n \in \mathbb{N} \wedge \forall i \in \{1, \dots, n\}, k_i \in Schedule\}$ ,
- $OrgIti: V \rightarrow Airport$ ,
- $DesIti: V \rightarrow Airport$ ,
- $NbFlights: V \rightarrow \mathbb{N}$ ,
- $DepTimeIti: V \rightarrow Slot$ ,
- $ArrTimeIti: V \rightarrow Slot$ ,
- $PaxTypeItiF: V \times PaxType \rightarrow \mathbb{N}^*$ ,
- $NextFlightIti: V \times Schedule \rightarrow Schedule \cup \emptyset$ ,
- $Aff_{Ini}^{Pax}: Reservation \rightarrow V$ .

This respects:

$$\forall s \in Reservation, \exists! v \in V, Aff_{Ini}^{Pax}(s) = v \quad \text{Eq. 17}$$

$$V_{Ini} = \{v \in V | \exists s \in Reservation, Aff_{Ini}^{Pax}(s) = v\} \quad \text{Eq. 18}$$

#### 4.1.10. Crews Data

Each flight is operated by a crew  $c$ . Each crew has a specific plan of flights to operate per day and given rules must be granted concerning the duty time (see section 3.1.2 for a high-level introduction). The main information required to allow calculating whether a crew is still valid for flying the flight or not, relies on:

$DutyCrewStart$  Function providing the start of the duty,

*DutyCrewEnd<sub>Ini</sub>* Function providing the initially planned end of duty,

*DutyCrewEnd<sub>Rel</sub>* Function providing the new end of duty time in the solution, which might be different due to delayed flights operated by this crew.

*LTOTCrew* Function providing the latest time at which a crew must arrive with their last planned flight before impacting the next operations and roster time (to calculate the operational influence of delays), in respect with the minimum resting time to guarantee to the crew before next duty).

*LastFlightCrew* Function providing the last flight operated by a crew as initially planned in the roster,

*DebriefingTime* Function providing the debriefing time compulsory after the last flight is operated,

*DutyTimeLimit* Function providing the legal maximum time of duty from the airline  $i$ ,

*DutyTimeLimit<sub>EASA</sub>* Function providing the legal maximum time of duty from EASA,

*CrewOwnership* Function providing the affiliation of crew to an airline.

We thus define:

- $DutyTimeLimit_{EASA} \in D$ ,
- $DutyCrewStart: Crew \rightarrow T$ ,
- $DutyCrewEnd_{Ini}: Crew \rightarrow T$ ,
- $DutyCrewEnd_{Rel}: Crew \rightarrow T$ ,
- $LastFlightCrew: Crew \rightarrow Schedule$ ,
- $DebriefingTime: Crew \rightarrow D$ ,
- $LTOTCrew: Crew \rightarrow AirportSlot \times Day$ ,
- $DutyTimeLimit: AirlinesGroup \rightarrow D$ , with:
- $\forall i \in AirlinesGroup$ ,

$$DutyTimeLimit(i) \leq DutyTimeLimit_{EASA} \quad \text{Eq. 19}$$

- *CrewOwnership*:  $Crew \rightarrow AirlinesGroup$ , with:

$$\forall c \in Crew, \exists! i \in AirlinesGroup, CrewOwnership(c) = i \quad \text{Eq. 20}$$

$$Crew_i = \{c \in Crew | CrewOwnership(c) = i\} \quad \text{Eq. 21}$$

#### 4.1.11. General Entry Parameters from the Users

$\delta \in \mathbb{R}$       Number of flights allowed to be delayed outside of the disruption timeframe,

$\beta \in D$       Maximum number of minutes between the initial departure time before the disruption and the proposed new departure time if the new slot is earlier than the initial one (by default 15 minutes at SWISS).

$\varphi \in D$       Maximum number of minutes of delay between the initial departure time before the disruption and the proposed new departure time if the new slot is later than the initial one.

## 4.2. Decision Variables

### 4.2.1. Decision Variables for the Planning Optimization

Let us define the following three decisions variables:

$Aff_{Rel}^{Slot}$       Function providing the new slot affected for the flight (0 being a cancellation),

### 4.2.2. Decision Variables for the Passengers Flow Optimization

Based on the planning of flights (which cancels and changes the scheduled departure time of some flights), we define:

$ResaPert$       The set of reservations impacted by the defined disruption (e.g., having a flight subject to a schedule change in comparison with the initial schedule or a cancellation),

$V_{Rel}$       The set of alternative itineraries feasible with the new planning for the reservations,

$V_s$       The set of feasible alternative itineraries realizable for a specific reservation  $s$ .

- $ResaPert \subseteq Reservation$ , with:

$$ResaPert =$$

$$\{s \in Reservation \mid k_{fp} \in Aff_{Ini}^{Pax}(s) \wedge Aff_{Rel}^{Slot}(k_{fp}) \neq Aff_{Ini}^{Slot}(k_{fp})\}$$

Eq. 22

- $V_{Rel} \subseteq V$ , with:

$$V_{Rel}$$

Eq. 23

$$= \left\{ v \in V_{Rel} \left| \begin{array}{l} (\forall k \in v, k \notin E^{Opti}) \\ \vee (\exists k_{fp} \in v, k_{fp} \in E^{Opti} \wedge Aff_{Rel}^{Slot}(k_{fp}) \neq 0) \\ \wedge Aff_{Rel}^{Slot}(k_{fp}) + BlockTime(k_{fp}) + GroundTime(Aff_{Ini}^{AC}(k_{fp})) \\ < Dep(NextFlightIti(v, k_{fp})) \end{array} \right. \right\}$$

- $V_s \subseteq V_{Rel}$ , with:

$$\forall s \in ResaPert,$$

$$V_s = \left\{ v \in V_{Rel} \left| \begin{array}{l} Org(v) = OrgAirport(s) \wedge Des(v) = DesAirport(s) \\ \wedge DepTimeIti(v) \geq OrgDepartureTime(s) \end{array} \right. \right\}$$

Eq. 24

Let us define the decision variable for the passenger flows optimization:

$Aff_{Rel}^{Pax}$  Function providing the new itinerary affected to a reservation in the solution.

$Aff_{Rel}^{Pax}: ResaPert \rightarrow V_{Rel} \cup \emptyset$ .

### 4.3. Associated Variables

$Dep_{Rel}$  Function providing the departure time of a flight  $k_{fp}$  according to the departure slot assigned in the new planning.

$Arr_{Rel}$  Function providing the arrival time of a flight  $k_{fp}$  according to the departure slot assigned in the new planning.

With:

- $Dep_{Rel}: E^{Opti} \rightarrow T$ ,
- $Arr_{Rel}: E^{Opti} \rightarrow T$ ,

- $\forall k_{fp} \in E^{Opti}$ ,

$$Arr_{Rel}(k_{fp}) = Aff_{Rel}^{Slot}(k_{fp}) + BlockTime(k_{fp}) \quad \text{Eq. 25}$$

$$\forall k_{fp} \in E^{Opti},$$

$$Dep_{Rel}(k_{fp}) = \begin{cases} Aff_{Rel}^{Slot}(k_{fp}) & \text{if } DepAirport(k_{fp}) = XYZ \\ Aff_{Rel}^{Slot}(k_{fp}) - BlockTime(k_{fp}) & \text{otherwise} \end{cases} \quad \text{Eq. 26}$$

$E^{OptiCNL}$  Function providing the set of flights cancelled in the new planning in the optimization window,

$E^{Late}$  Function providing the set of flights impacting the following operations in the new planning due to landing later than their LTOT.

As a reminder, the LTOT corresponds to the latest time of arrival without impacting the rest of operations through crew, aircraft rotation delay or passenger connections delay.

- $E^{OptiCNL} \subseteq E^{Opti}$

$$E^{OptiCNL} = \{k_{fp} \in E^{Opti} \mid Aff_{Rel}^{Slot}(k_{fp}) = 0\} \quad \text{Eq. 27}$$

- $E^{Late} \subseteq E^{Opti}$ , with:

$$E^{Late} = \{k_{fp} \in E^{Opti} \mid Arr_{Rel}(k_{fp}) > LTOT(k_{fp})\} \quad \text{Eq. 28}$$

$\forall i \in AirlinesGroup$ ,

$NBFlightSol_i$  Function providing the number of planned flights operated by an airline  $i$  in the new planning.

$NBFlightPushedOutIncidentSol_i$  Function providing the number of flights operated by an airline  $i$  initially planned in the disruption window and delayed outside of the disruption window in the new planning.

$NBCancGroup_{Opti}$  Function providing the amount of flight cancelled for the group in the new planning on the optimization time window.

$NBCancGroup_{Incident}$  Function providing the amount of flight cancelled for the group in the new planning on the disruption time window.

Such as:

- $NBFlightSol_i \in \mathbb{N}$ , with:

$$NBFlightSol_i = Card(\{k_{fp} \in E_i^{Opti} \mid Aff_{Rel}^{Slot}(k_{fp}) \neq 0\}) \quad \text{Eq. 29}$$

- $NBFlightPushedOutIncidentSol_i \in \mathbb{N}$

$$NBFlightPushedOutIncidentSol_i \quad \text{Eq. 30}$$

$$= Card(\{k_{fp} \in E^{Incident} \cap E_i^{Opti} \mid Aff_{Rel}^{Slot}(k_{fp}) \notin \{0, ]TdisruptionBegin(XYZ), TdisruptionEnd(XYZ)[\}\})$$

- $NBCancGroup_{Opti} \in \mathbb{N}$ ,

$$NBCancGroup_{Opti} = Card(E^{OptiCNL}) \quad \text{Eq. 31}$$

- $NBCancGroup_{Incident} \in \mathbb{N}$ ,

$$NBCancGroup_{Incident} = Card(E^{Opti}) - Card(E^{OptiCNL}) \quad \text{Eq. 32}$$

$$DutyCrewEnd_{Rel}: Crew \rightarrow T$$

$\forall c \in Crew,$

*If LastFlightCrew(c)  $\in$  FlightPerturbed,*

$$\begin{aligned} \exists k_{fp} \in E^{Opti}, k_{fp} = LastFlightCrew(c) \wedge DutyCrewEnd_{Rel}(c) \\ = Arr_{Rel}(k_{fp}) + DebriefingTime(c) \end{aligned} \quad \text{Eq. 33}$$

*If LastFlightCrew(c)  $\notin$  FlightPerturbed,*

$$DutyCrewEnd_{Rel}(c) = DutyCrewEnd_{Ini}(c) \quad \text{Eq. 34}$$

$$\begin{aligned}
 &+ \left( \text{Max} \left( \text{Dep}_{Ini}(\text{LastFlightCrew}(c)); \text{Arr}_{Rel}(k_{fp}) \right. \right. \\
 &\quad \left. \left. + \text{GroundTime} \left( \text{TailProperty} \left( \text{Aff}_{Rel}^{AC}(k_{fp}) \right), \text{AirlineF}(k_{fp}) \right) \right) \right) \\
 &\quad \left. - \text{Dep}_{Ini}(\text{LastFlightCrew}(c)) \right)
 \end{aligned}$$

#### 4.4. Constraints

##### 4.4.1. Constraints for the Planning Optimization

The decision function  $\text{Aff}_{Rel}^{Slot}$  verifies that:

- Enough ground time is guaranteed between two flights of a same rotation, according to the aircraft considered: As the disrupted airport is an outstation, it is necessarily the arrival airport of the rotation's first flight (see Figure 7).

$$\forall k_{fp} \in E^{Opti}, \text{Arr}_{Airport}(k_{fp}) = XYZ,$$

$$\text{Aff}_{Rel}^{Slot}(\text{NextFlight}(k_{fp})) \geq \text{Aff}_{Rel}^{Slot}(k_{fp})$$

Eq. 35

$$\begin{aligned}
 &+ \text{GroundTime} \left( \text{TailProperty} \left( \text{Aff}_{Rel}^{AC}(k_{fp}) \right), \text{AirlineF}(k_{fp}) \right) \\
 &\quad + \text{BlockTime}(k_{fp})
 \end{aligned}$$

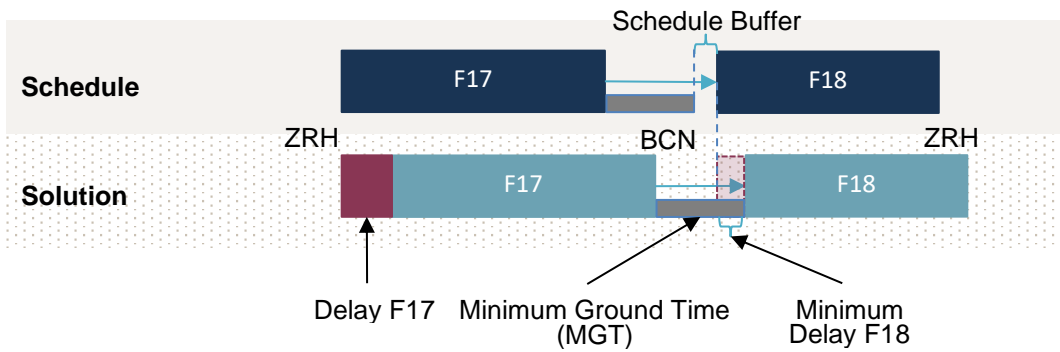

Figure 7: Illustration of a delay on the first flight of a rotation and the minimum.

- The flights from the optimized schedule must comply with the opening and closing times of their departure and arrival airports (see Figure 8). As the hub of an airline might have earlier opening time or later closing time than for the other airlines, this must be considered.

$$\forall k_{fp} \in E^{Opti}, DepAirport(k_{fp}) = Hub(AirlineF(k_{fp})),$$

$$OpeningTime(DepAirport(k_{fp})) = OpeningTime(Hub(AirlineF(k_{fp}))) \quad \text{Eq. 36}$$

$$\forall k_{fp} \in E^{Opti}, ArrAirport(k_{fp}) = Hub(AirlineF(k_{fp})),$$

$$ClosingTime(ArrAirport(k_{fp})) = ClosingTime(Hub(AirlineF(k_{fp}))) \quad \text{Eq. 37}$$

Such as:

$$\begin{aligned} & Dep_{Rel}(k_{fp}) \\ & \geq \max(OpeningTime(DepAirport(k_{fp})), OpeningTime(ArrAirport(k_{fp})) \\ & - BlockTime(k_{fp})) \end{aligned} \quad \text{Eq. 38}$$

$$\forall k_{fp} \in E^{Opti},$$

$$\begin{aligned} & Dep_{Rel}(k_{fp}) \\ & \leq \min(ClosingTime(DepAirport(k_{fp})), ClosingTime(ArrAirport(k_{fp})) \\ & - BlockTime(k_{fp})) \end{aligned} \quad \text{Eq. 39}$$



Figure 8: Illustration of Departure Constraints caused by the opening and closing time of the airports.

- The flights cannot be planned more than  $\beta$  minutes before their original schedule ( $\beta$  is divided by 5 as the slots are during 5min in Europe)

$$\forall k_{fp} \in E^{Opti},$$



$$Arr_{Rel}(k_{fp}) - Arr_{Ini}(k_{fp}) \leq \frac{\beta}{5} \quad \text{Eq. 40}$$

- The number of cancelled flights on the disruption window for the entire group of airlines complies with the required cancellations amount requested by the user.

*NBCancReqGroupMin* Minimum number of cancellations required for the considered group of airlines.

*NBCancReqGroupMin*  $\in \mathbb{N}$ , with:

$$NBCancReqGroupMin = \left\lceil RedCap \times \sum_{i=1}^{NBairlGroup} Card \left( E_{k_{fp}}^{Incident} \cap E_{k_{fp},i}^{Opti} \right) \right\rceil \quad \text{Eq. 41}$$

$$NBCancReqGroupMin \leq NBCancGroup_{Incident} \quad \text{Eq. 42}$$

- The number of flights initially planned in the disruption timeframe that are assigned to a new slot in the optimization timeframe and outside of the disruption timeframe (to avoid a cancellation) must be limited to a small amount, defined as a user input.

$$NBFlightPushedOutIncidentSol_i \leq \delta \quad \text{Eq. 43}$$

- In the new solution, if one flight of a rotation is cancelled, the other flight of the same rotation must also be cancelled:

$$\forall k_{fp} \in E^{Opti},$$

$$\text{If } Aff_{Rel}^{Slot}(k_{fp}) = 0, \text{ then } \forall k' \in Rotation(k_{fp}), Aff_{Rel}^{Slot}(k') = 0 \quad \text{Eq. 44}$$

- If neither the departure nor arrival of flight are planned in a peak time, then this flight shall not be delayed such that the departure or arrival happens within a defined peak time.

$$\forall k_{fp} \in E^{Opti}, \forall i \in AirlinesGroup, \forall (S_1, S_2) \in PeakTime_i,$$

$$\begin{aligned} \text{If } Aff_{Ini}^{Slot}(k_{fp}) \notin PeakTimeF((S_1, S_2)), \text{ then } Aff_{Rel}^{Slot}(k_{fp}) \\ \notin PeakTimeF((S_1, S_2)) \end{aligned} \quad \text{Eq. 45}$$

- If the flight is in the list of critical flights for the 80/20 airport slot rule, then the slot cannot be changed more than 15min +/- its original schedule nor cancelled. As the slots in *Slot* are defined every 5min, 15min corresponds to 3 slots different in comparison with the initial one.

$$\forall k_{fp} \in E^{Opti}, Flight^{NoCNL}(k_{fp}) = 1,$$

$$Aff_{Rel}^{Slot}(k_{fp}) \in [Aff_{Ini}^{Slot}(k_{fp}) - 3, Aff_{Ini}^{Slot}(k_{fp}) + 3] \quad \text{Eq. 46}$$

#### 4.4.2. Constraints for the Passenger Flow Optimization

We first need to define the functions *CapaFlight*, *CapaItinerary* and *CapaItineraryPerClass* to write properly the constraint:

*CapaFlight*            Function providing the seat capacity of a flight and a specific booking class.

*CapaItinerary*        Function providing the seat capacity of an itinerary, all booking classes together.

*CapaItineraryPerClass*    Function providing the seat capacity of an itinerary per booking class.

*ResaPertType<sub>pt</sub>*        Set of disrupted reservations with passenger of a specific booking class pt.

*ResaPertFlightIni<sub>v</sub>*, Set of reservations disrupted initially booked on the itinerary *v*.

*ResaPertItinerary<sub>v</sub>*, Set of all reservation assigned to itinerary *v* by the decision variable for the passengers.

It must be noted that the capacity for the itinerary corresponding to the cancellation of the itinerary (e.g., no alternative itinerary found) is infinite. This allow the constraint that all reservation disrupted must be assigned to an alternative itinerary is respected. However, this is

considered in the solution's performance indicators, and many reservations with no alternative itineraries other than *CNL* is penalizing the solution global performance.

Let us define:

- $CapaFlight: Schedule \times PaxType \rightarrow \mathbb{N}$ ,
- $CapItinerary: (V_s \cup \emptyset) \rightarrow \mathbb{N}^*$ ,
- $CapItineraryPerClass: (V_s \cup \emptyset) \times PaxType \rightarrow \mathbb{N}^*$ ,
- $ResaPertType_l \in ResaPert$ ,
- $ResaPertFlightIni_v \in ResaPert$ ,
- $ResaPertItinerary_v \in ResaPert$ ,
- $CapItinerary(\emptyset) = \infty$ ,
- $\forall pt \in PaxType$ ,

$$ResaPertType_{pt} = \{s \in ResaPert | PaxTypeF(s) = pt\} \quad \text{Eq. 47}$$

- $\forall v \text{ in } V_{Ini}$ ,

$$ResaPertFlightIni_v = \{s \in Reservation | Aff_{Ini}^{Pax}(s) = v\} \quad \text{Eq. 48}$$

- $\forall v \in V_{Rel}$ ,

$$ResaPertItinerary_v = \{s \in Reservation | Aff_{Rel}^{Pax}(s) = v\} \quad \text{Eq. 49}$$

- $\forall v \in V, \forall pt \in PaxType$ ,

$$\begin{aligned} & CapItineraryPerClass(v, pt) \\ &= PaxTypeItiF(v, pt) \\ &+ \sum_{s \in ResaPertType_{pt} \cap ResaPertFlightIni_v} NBPax(s) \end{aligned} \quad \text{Eq. 50}$$

$$CapaItinerary(v) = \sum_{pt \in PaxType} CapaItineraryPerClass(v, pt) \quad \text{Eq. 51}$$

The decision function  $Aff_{Rel}^{Pax}$  verifies the following constraint:

- The maximum capacity of each itinerary is respected:

$$\forall v \in V_{Rel},$$

$$\forall v \in V_{Rel},$$

$$\sum_{s \in ResaPertItinerary_v} NB Pax(s) \leq Capa(v) \quad \text{Eq. 52}$$

## 4.5. Indicators

### 4.5.1. General

The goal of this multi-criteria evaluation is to find the most optimal solutions with a group vision.

The following criteria tree Figure 9 was designed and validated thanks to the participation of operational experts from different airlines, all working in the operations with a group vision component (by either projects, processes, or innovation for the airline group). Three main categories were first identified: the impact of a solution on the passengers, the impact on the crews, and the impact on the global operations.

Concerning the impact on the passengers, three possibilities for a booking can exist, all with the main flights being operated by the airlines group:

- a rebooking with no delay and no up/downgrading or on simply the initial itinerary,
- a rebooking with associated costs (with delay and/or necessary up/downgrade),
- no rebooking possible on the same day.

As these three categories cover all possibilities, only two of them must be assessed to avoid redundancy. Therefore, the two main sub-criteria for the passenger performance are the bookings with costs associated, and the bookings with no rebooking on the same day. Depending on the booking class and the status of the passengers (VIP, staff, etc. see section

4.1.5), the rebooking options of the passengers might have higher or lower costs for the airlines. Therefore, the two categories chosen for calculating the passenger performances are themselves split in four different sub-categories: highest priority, high priority, medium priority, and low priority.

Concerning the Crews performance, as no changes of crews are enabled in this group optimization (it belongs to the sovereignty of the local airlines as the rules are all very complex, specific to each airline and fall under employees' contract and national labor agreements), only the impact of a solution is assessed. This impact assessment covers:

- the deadhead crews impacted by a cancellation (which means that they cannot reach the airport from which they were operating their next flight or end their duty),
- the crews reaching the legal maximum duration of their duty requiring a local crews optimization to solve the problem on the day of disruption (duty time limit imposed by the airlines group and the one from the European Aviation Safety Agency),
- the crews that are ending their duty time later than planned due to delays, and not having the minimum legal resting time before their next duty plan on the next day (need for a local crew optimization for the next day),
- the crews that might claim “fatigue”, which leads – for safety reason – to immediate diversion to the nearest airport and the cancellation of all the consequent flights planned to be operated by the same crew (except if another crew can be found to replace the one reporting the fatigue).

Finally, the operational performance can be measured thanks to four sub-criteria:

- the operational flexibility, which corresponds to a measure of the available reserve aircraft to enable easy solutions for local problem thanks to aircraft or equipment swap (aircraft swap from different sub-fleets),
- the operational impact, which corresponds to a measure of all aircraft landing with delay impacting their next planned flight,
- the non-respected tokens: as the airlines users are indicating some flights having a high priority, these flights should be as far as possible not cancelled nor delayed.

All the criteria and the corresponding sub-criteria are illustrated here below in the criteria tree. All of them are meant to be minimized.

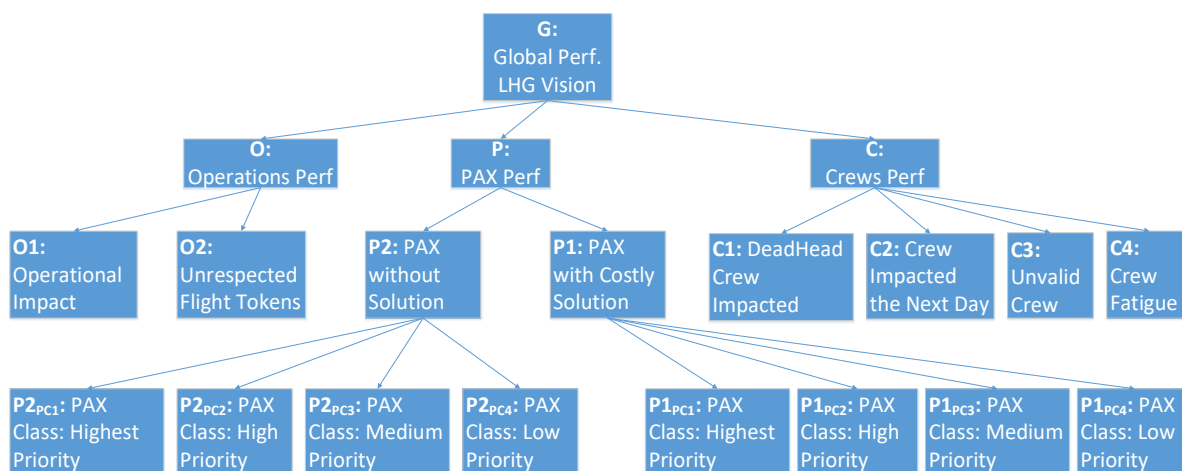

Figure 9: Criteria tree identified for the Lufthansa Group to evaluate group solution.

Each sub-criteria identified and agreed in the criteria tree have been defined, formulated mathematically here below and then traduced into a simple pseudo-code.

#### 4.5.2. P: Passengers Indicators

Different Passengers categories exists, having different impacts on the disruption costs. Based on the passenger categories as defined in section 4.1.5, the performances are indexed by  $b$ .

##### 4.5.2.1. P1<sub>PC1</sub>, P1<sub>PC2</sub>, P1<sub>PC3</sub> & P1<sub>PC4</sub>: Passengers with Costly Solution

A reservation  $s$  has a costly solution, if an alternative itinerary exists but that this itinerary is not satisfying the following conditions:

- In case of a “normal” (non-extraordinary) event: arrival time after the threshold defined by the EUC 261 rule (triggering financial compensations from the airline to the passenger, vouchers, etc.).
- In case of an extraordinary event, either the considered reservation has a satisfying solution - arriving on the same day than the initially planned one – or no solution.
- Downgrading of the passenger class initially booked (valid for extraordinary and non-extraordinary events).

To enable the passenger indicators calculations,  $dSeuil$  and  $satisCosts$  must be defined.

$$\forall pc \in PaxCategory,$$

$dSeuil: \mathbb{N} \rightarrow D$  Function providing the maximum delay in minutes that is acceptable for a reservation  $s$  without triggering financial compensation to be paid by the airline to the passengers, as from the law EUC261 (which is based on the distance in km between the origin and destination airport of the considered reservation  $s$ ).

$ResaPertCategory_{pc}$  Set of reservation with a specific category

$satisCosts$  Function providing the indication if a reservation is assigned on an itinerary causing costs because of delay or downgrade.

These are defined as follow:

- $\forall s \in Reservation, \text{ and if } ExtraordinaryEvent = 0$

$$dSeuil(Dist(s)) = \begin{cases} 120 & \text{if } Dist(s) \leq 1500 \\ 180 & \text{if } 1500 < Dist(s) \leq 3500 \\ 240 & \text{if } Dist(s) > 3500 \end{cases} \quad \text{Eq. 54}$$

- $\forall b \in PaxCategory,$

$$ResaPertCategory_{pc} = \{s \in ResaPert \mid PaxCategoryF(s) = pc\} \quad \text{Eq. 55}$$

- $SatisCost: Reservation \times PaxCategory \rightarrow \{0,1\}$ 
  - If a disruption is not categorized as an Extraordinary Event, the airlines must compensate the passengers in case of delays above a certain threshold or a downgrade. The delay threshold is depending on the distance between the origin and destination of the passenger's itinerary and is regulated by the EUC261 rule.

$$\forall pc \in PaxCategory, \forall s \in ResaPert,$$

$$\text{If } ExtraordinaryEvent = 0,$$

$$satisCosts(s, pc)$$

$$= \left\{ \left( \left( \left( \left( \left( ArrTime(v) - DesArrivalTime(s) \geq dSeuil(Dist(s)) \right) \right) \vee PaxTypeItiF(v) < PaxTypeF(s) \right) \right) \right) \right) \right\} \quad \text{Eq. 56}$$

$$0 \text{ otherwise}$$

- In the case of a disruption categorized as an Extraordinary Event, the airlines must compensate the passengers only in case of downgrade (and not according to the delay). This is regulated by the EUC261 rule.

*If ExtraordinaryEvent = 1,*

$$satisCosts(s, pc) = \begin{cases} 1 \text{ if } (PaxCategory(s) = bpc \wedge \exists v \in V_s, Aff_{Rel}^{Pax}(s) = v) \\ \quad \wedge PaxTypeItiF(v) < PaxTypeF(s) \\ 0 \text{ otherwise} \end{cases} \quad \text{Eq. 57}$$

$\forall ExtraordinaryEvent \in \{0,1\}, \forall pc \in PaxCategory,$

$$P1_{pc} = \frac{\sum_{s \in ResaPertCategory_{pc}} (NBPax(s) \times satisCosts(s, pc))}{\sum_{s \in ResaPertCategory_{pc}} NBPax(s)} \quad \text{Eq. 58}$$

Objective: minimize  $P1_{pc}$

#### 4.5.2.2. P2<sub>PC1</sub>, P2<sub>PC2</sub>, P2<sub>PC3</sub> & P2<sub>PC4</sub>: Passengers Without Solution

A reservation  $s$  has no solution, if the passenger optimizer has found no alternative itinerary on Lufthansa Group flights on the same day, and consequently will lead either to a rebooking on another airline outside of the group or to a hotel compensation.

$ResaPert_{CNL}$  Function providing all the reservation for which no alternative itineraries were assigned in the solution, and that are considered as cancelled (CNL).

$$ResaPert_{CNL} = \{s \in ResaPert \mid Aff_{Rel}^{Pax}(s) = \emptyset\} \quad \text{Eq. 59}$$

$\forall ExtraordinaryEvent \in \{0,1\},$

$$P2_{pc} = \frac{\sum_{s \in ResaPertCategory_{pc} \cap ResaPert_{CNL}} (NBPax(s) \times satisCosts(s, b))}{\sum_{s \in ResaPertCategory_{pc}} NBPax(s)} \quad \text{Eq. 60}$$

Objective: minimize  $P2_{pc}$



### 4.5.3. C: Crew Indicators

#### 4.5.3.1. C1: Amount of Deadhead Crew Impacted by the Solution

Deadhead crews are the crew that are flying as passengers (so sitting on a normal seat) in a flight, either to be the “active” crew on a flight departing from another airport or coming back from duty stopping in an outstation. It is important to know how many deadhead crewmembers are impacted to assess the complexity of the operations due to late crews or no crews able to operate the flight from the outstation. These crews should normally appear in the passenger booking data as passengers with special status but appears also in the crewmembers list for the given flights, with a specific status indicating that they are deadhead flying crews.

SWISS agreed to calculate this indicator in two steps depending on the data available and the stability of the optimizer:

- Firstly, we calculate only the deadhead crewmembers impacted by a cancellation,
- Secondly, we could add all crewmembers impacted also by a delay that would impact their next flight that they are planned to operate (so all crews arriving later than:  $STD(\text{flight to be operated by the crew}) - \text{MinimumCrewConnectingTime}$ ).

$ResaPert_{Ini}^{k_{fp}}$  Function providing the reservation initially planned on a flight  $k_{fp}$ .

$ResaPert_{DHC}$  Function providing the crew flying as deadhead crew on cancelled flights.

- $ResaPert_{Rel}^{k_{fp}} \in \text{Reservation}$ , with:

$$ResaPert_{Rel}^{k_{fp}} = \{s \in ResaPert \mid \exists k_{fp} \in E^{Opti} \wedge k_{fp} \in Aff_{Rel}^{Pax}(s) \wedge Aff_{Rel}^{Slot} = 0\} \quad \text{Eq. 61}$$

- $ResaPert_{DHC} \in \text{Reservation}$ , with:

$$ResaPert_{DHC} = \{s \in ResaPert \mid PrioPax(s) = "PaxDHC"\} \quad \text{Eq. 62}$$

$$\forall s \in ResaPert, tq \ PrioPax(s) = PaxDHC,$$

$$C1 = \frac{\sum_{k_{fp} \in E^{OptiCNL}} \sum_{s \in ResaPert_{Rel}^{k_{fp}}} (NBPax(s))}{\sum_{E^{Opti}} \sum_{s \in ResaPert} NBPax(s)} \quad \text{Eq. 63}$$

Objective: minimize C1

**4.5.3.2. C2: Amount of late crew impacting the next day.**

Crews are entitled to have a minimum resting time between two duties. If a crew is arriving later than originally planned, these crewmembers will be allowed to fly again only after the minimum resting period. Delaying flights can then affect the flights of the following day planned to be operated by some of the delayed crewmembers. Therefore, it is an important indicator to assess, to know the impact to be foreseen on the next day of operations.

$Crew_{>LTOT}^{Opti}$  Set of crews impacting the following operations in the new planning, as their duty time ends after their respective LTOT (Last Time Of Touchdown)

- $Crew_{>LTOT}^{Opti} \subseteq Crew$ , with:

$$Crews_{>LTOT}^{Opti} = \{c \in Crew \mid DutyCrewEnd_{Rel}(c) > LTOTCrew(c)\} \quad \text{Eq. 64}$$

$$C2 = \sum_{c \in Crew_{>LTOT}^{Opti}} \frac{Card(Crew_{>LTOT}^{Opti})}{Card(Crew)} \quad \text{Eq. 65}$$

Objective: minimize  $C2$

**4.5.3.3. C3: Amount of invalid crew in the proposed solution due to overreaching the legal duty time limits.**

Crewmembers are entitled to work a given amount of time, which is regulated by the EASA and shall be respected by each airline in the world. If a flight is delayed so that the crewmembers would land later than their calculated Flight Duty Time Limit, the crew is considered in our problem as “invalid”, and the crew control team must find a solution. Therefore, it is important to know how many crewmembers would be invalid in the proposed solution.

*DutyTime* Function providing the duty time of the crew  $c$  at time  $t$ .

*DutyTimeValidity* Function proving crew’s validity towards the airline’s and EASA’s rules.

- $DutyTime: Crew \rightarrow T$ , with:

$$\forall i \in AirlinesGroup, \forall c \in Crew_i, t \in T,$$

$$DutyTime(c, t) = t - DutyCrewStart(c) \quad \text{Eq. 66}$$

- *DutyTimeValidity*:  $Crew \rightarrow \{0,1\}$ , with:

$$DutyTimeValidity(c, t) = \begin{cases} 0 & \text{si } DutyTime(c, t) < DutyTimeLimit_i \\ 1 & \text{si } DutyTime(c, t) \geq DutyTimeLimit_i \end{cases} \quad \text{Eq. 67}$$

$$C3 \quad \text{Eq}$$

$$= \frac{\sum_{i \in AirlinesGroup} \sum_{k_{fp} \in E_i^{Opti}} DutyTimeValidity(Aff_{Rel}^{Crew}(k_{fp}), DutyCrewEnd_{Rel}(Aff_{Rel}^{Crew}(k_{f_i})))}{Card(E^{Opti})} \quad 68$$

Objective: minimize  $C3$

#### 4.5.3.4. C4: Crew Fatigue

Crews are planned to work until a given time, which is corresponding to a shorter period than the legal maximum of flight duty time. However, if a flight is delayed, which could affect all the planned flights afterwards and lead to a later end of duty for the crew, the crewmembers have the right to declare them under “fatigue”, which lead to the direct diversion of the current flight or the cancellation/need for a new crew for the following flights. This is important for some airlines to know, as this could be a recurrent problem.

$Crew_{Fatigue}^{Opti}$  Set of crews that could be subject to fatigue in the new planning, at their end of duty in the new planning is later than the initially planned one, but still happening before their respective LTOT.

For a better comprehension of the reader, it is important to know this kind of delays can lead at some airline to the legal notification of “fatigue” sent by the crew to an airline, which results in diversion or cancellations of the remaining flights).

- $Crew_{Fatigue}^{Opti} \subseteq Crew$ , with:

$$Crews_{Fatigue}^{Opti} = \{c \in Crew \mid DutyCrewEnd_{Ini}(c) < DutyCrewEnd_{Rel}(c) \wedge DutyCrewEnd_{Rel}(c) < LTOTCrew(c)\} \quad \text{Eq. 69}$$

$$C4 = \frac{Card(Crew_{Fatigue}^{Opti})}{Card(Crew)} \quad \text{Eq. 70}$$

Objective: minimize  $C4$

#### 4.5.4. O: Operational Indicators

##### 4.5.4.1. O1: Operational Impact

For each flight, a Last Take-Off Time (and with the dedicated flight time + Taxi Out, one can calculated the LTOT: Last Time Of Touchdown) can be calculated so that this represents the last time at which the flight can depart (and then dock to the gate) with no impact on the planned operations, for example via reactionary delay.

$$O1 = \frac{Card(E^{Late})}{Card(E^{Opti})} \quad \text{Eq. 71}$$

Objective: minimize  $O1$

##### 4.5.4.2. O2: Unrespect of Tokens Protecting Flights

For each of its flights caught into the optimization window, the airline can indicate the important ones thanks to tokens. It could be that the new schedule proposed by the particle with cancellations and delays are not respecting these tokens/priorities (as this is no hard constraints). Therefore, it is important to assess the number of flights affected by a cancellation or a delay despite the priorities/tokens allocated by the airline.

We discussed and agreed with the operational experts to calculate this indicator in two steps depending on the data available and the stability of the optimizer:

- First: we consider only the tokens on flights impacted by a cancellation,
- Second: we could consider also the tokens allocated to flights that are delayed (For delay in [0;15min], all tokens respected; for delay in [15;30min], 75% of tokens respected; for delay in [30;60min], 50% of tokens respected; for delay in [60;120min], 25% of tokens respected; for delay >120min, 0% of tokens respected.

$$O2 = \frac{\sum_{i \in AirlinesGroup} Card(\{k_{fp} \in E_i^{Prio} \mid Aff_{Ret}^{Slot}(k_{fp}) = 0\})}{\sum_{i \in AirlinesGroup} Card(E_i^{Prio})} \quad \text{Eq. 72}$$

Objective: Minimize  $OZ$

#### 4.6. Chapter Conclusion

This chapter aimed at providing a clear understanding of the problem by defining the inputs data, their mathematical formulation, and their relationships. The decision variables highlight the key elements to optimize in our multi-airline operations optimization problem, along with the related constraints and associated variables. Different indicators are introduced, and commonly agreed with various operational managers and experts. Even if airlines have similar business and thus operational priorities, the indicators definition might slightly differ. The weights of each indicator in the global solution assessment can be perceived differently by different airlines' users. Therefore, the multi-airlines operations optimization approach necessitates a multi-stakeholder approach conciliating the different visions, guaranteeing the optimum for the group – group vision – while respecting the local strategies, needs and constraints – airline vision – (see chapter 5 and chapter 6).

Based on this mathematical refinement of the problem, a better knowledge of the group optimization can be illustrated as below in Figure 10. The tasks P1 and P2 enable to gather the definition of the disruption and the preferences and specific data from each airline. The task P3 optimizes the schedule and the passengers flow according to a group objective function, based on a multi-criteria decision-making method, as explained in section 3.1.3. This enables to identify the best combination of delay and cancellation within all the airlines group's flights, and to find the best solutions for the passengers on all itineraries possible with the new schedule. As the crew problem is not optimized as such in the group approach (see section 3.1.2), the crew indicators are considered in the evaluation of each solution proposed by the optimizer, assessing the crew usage, complexity and operational impact (see the exact definitions section 4.5.3). Among the best solutions found by the optimizer, the airlines are invited to provide their preferences and rank them. The task P4 is supporting the decision-maker in the ranking as many attributes can come into account (see section 3.1.4). Once all airlines participating ranked the solution according to their priorities and business impact, task P5 is running, identifying the consensus between all airlines' views. Finally, task P6 monitors the long-term equity on the historical previous instances. This relies on the airlines' vision and solutions assessment and aims at being an interactive and transparent process with all users to build on the trust in the system. The elicitation of the group solution to implement can incorporate a compensation mechanism in case of historical inequity within the airlines.

## Chapter 4 - Mathematical Formulation of the Group Airlines Optimization

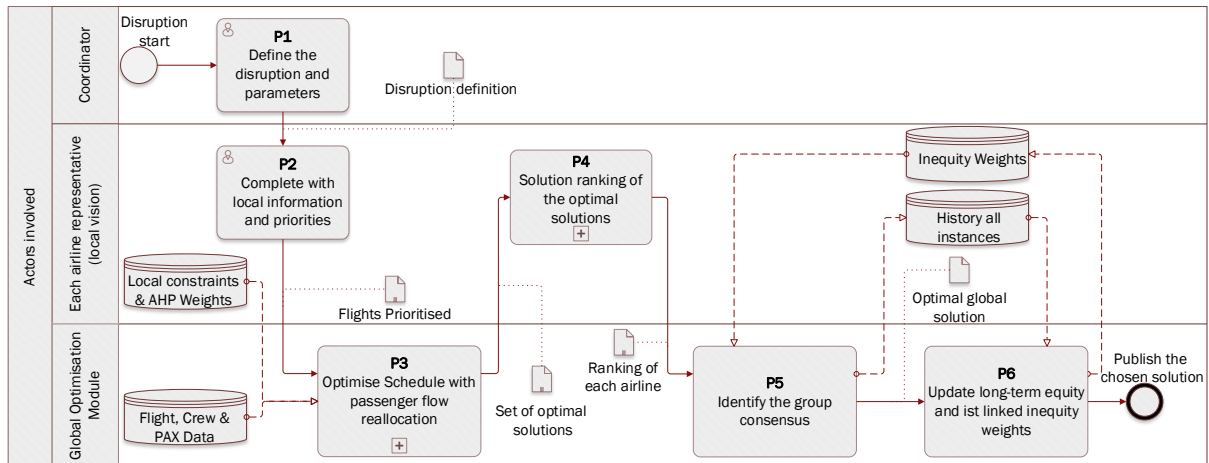

Figure 10: Business Process Model and Notation of the methodology proposed.

The next part will present the existing methods for multi-stakeholders' multi-criteria decision-making and highlight the developed approach for the Global Optimization Module.



# Multi-Stakeholders Decision Making and Long-Term Equity Method

---

In a group decision, all stakeholders must be included in the definition of the optimization objectives and in the relative importance setting of the different objectives towards the others. As the optimizer must run in a short computing time, no human inputs must be required once started, and the solution assessment function with a group vision must be agreed upon on (see chapter 5). Once the optimizer proposes different optimal solutions based on this group objective function, each stakeholder must actively participate in the identification of the solution to implement, to express its preferences among the solutions. Indeed, some solutions could hamper more its airline's operations than others. This assessment of all the solutions can be complicated due to all the information to consider. Therefore, a decision-making support must be proposed, to help the airline easily assess the solutions, and the elicitation of the solution to implement must be a transparent and understandable process for all (see chapter 6). As the solution chosen by the airlines to implement might disfavor some of them, an important part of a group optimization is to monitor the equity among the airlines participating on the long-term. Indeed, while a strict equity on each instance is not wished to enable better solutions for the group, a global equity must be ensured on the long-term (see chapter 7). If one airline were to be always penalized by a group optimal solution, the group optimization should be questionable and refined.

This chapter aims at providing more insights on the methods chosen, and the developed approaches offering a transparent, clear, and trusted process of group decision.



## **5. Multi-Criteria Approach for a Group Decision Making**

A multi-airlines operations optimization system necessitates a reliable method to ensure that the optimizer search for an unbiased group optimum. A multi-stakeholders group vision must be defined transparently and accepted by all. However, this group vision definition must not be the result of airlines' consultation at each use of the optimizer and must also rely on easily adaptable inputs from each airline independently of the others. This corresponds to the step S3 on Figure 4, p. 30, which is part of the task P3 from Figure 10, p. 73. The goal is to define an efficient evaluation function with a group vision, to assess all solutions proposed by the optimizer.

When optimizing on several criteria, the solution can be evaluated either through a macro indicator – which means that all criteria are aggregated – or independently on several objectives (multi-objective approach). A Multiple-Objective Decision-Making (MODM) approach is very well suited for optimization problems that are having conflicting objectives, and for which one user can decide at the end between different solutions (Morales-Hernández *et al.*, 2022). To respect a group vision and ensure a clear and transparent solution evaluation, a Multi-Criteria Decision-Making (MCDM) approach is better-suited (see section 3.1.3). This chapter aims at presenting a literature review of the main multi-criteria methods used in the operations research community and then present, argue and illustrate the approach developed for a Global Optimization Module.

### **5.1. Literature Review on Multi-Criteria Decision-Making**

Multi-criteria optimization necessitates an evaluation of the potential solutions, so that it respects the balance wished by the decision-maker between all criteria and correctly reflect a global assessment of the solutions performances. Numerous approaches exist, with their advantages and drawbacks. The goal of this section is to offer to the reader a high-level knowledge of the main methods used in operations research and provide a comprehensive positioning for group decision making. A good literature review is provided by (Yannis *et al.*, 2020) on the MCDM methods used for transportation problems, and by (Dožić, 2019) for an extensive review of the methods used in aviation, including methods used by airlines.

MCDM methods providing an aggregated performance are generally split into two main categories: aggregative methods and outranking methods (Kumar *et al.*, 2017). These methods are described in the sub-sections below.

### 5.1.1. MCDM Aggregative Methods

MCDM additive methods consist in adding the different criteria's performances multiplied by given weights. Most of the methods rely on criteria independent one of each other and on user acceptance that none are interacting. In the following sections, we write:

- $i \in \{1, \dots, N\}$  being a criterion among  $N$  criteria,
- $S$  the set of solutions, with an element of it being noted  $s_j, j \in \{1, \dots, J\}$ ,
- $\forall i \in \{1, \dots, N\}, s_{j,i}$  the performance of the solution  $s_j$  for criterion,
- $\forall i \in \{1, \dots, N\}, w_i$  the weight of criterion  $i$ ,
- $f: S \rightarrow [0,1]$  the normalized fitness function of a solution.

#### 5.1.1.1. Simple Additive Weight

Simple Additive Weight is one of the easiest aggregation methods. It consists in calculating the performance of a solution by adding the performances of each criterion multiplied by its respective normalized weight ( $\sum_{i=1}^N w_i = 1$ ). This method is intuitive and thus easily understandable by decision-makers. However, this is appropriated only if the criteria are independent, and the output of this method is not always representing the reality and can bring illogical results, especially in case of multiple decision-makers. Indeed, the main difficulties are the weight procurement and the compensation phenomena.

$$\forall s_j \in S, f_{SAW}(s_j) = \sum_{i=1}^N w_i \times s_{j,i} \quad \text{Eq. 73}$$

(Dožić, 2019) reported use of the Simple Additive Weight methods in different articles evaluating competitiveness, preferable airline image, ground handlers and MRO (Maintenance, Repair and Operations) providers. In a group decision-making, the weights must be carefully identified and agreed among all users. A proved and dedicated method should be proposed to be accepted by all airlines. One main challenge with this method is the compensation

phenomena between the performances of different criteria that cannot be spotted though the aggregated value.

### 5.1.1.2. Weighted Product Model

The Weighted Product Model first introduced by (Bridgman, 1922) multiply the performance of each criterion, itself at exponent of a weight, which is positive if the criterion is beneficial to the solution or negative if the criterion is a disadvantageous for the solution (best practice is however to define the criteria such as they all are advantageous or disadvantageous for the solution). This enables to use non-normalized weights as well as different criteria that may be maximized or minimized independently. This method however can bring illogical results if the weights are not carefully defined (Taddese, 2021).

$$\forall s_j \in S, f_{WMP}(s_j) = \prod_{i=1}^N (s_{j,i})^{w_i} \quad \text{Eq. 74}$$

### 5.1.1.3. Technique for Order of Preference by Similarity to Ideal Solution (TOPSIS)

TOPSIS method, proposed by (Hwang and Yoon, 1981), consists in assessing each solution criterion in comparison with the “positive” ideal solution  $s^+$  (even if not realistic) and “negative” ideal solution  $s^-$ . It calculates the Euclidean distance of each solutions’ criterion to identify the solution, which is the closest to the positive ideal solution and the farthest to the negative ideal solution. However, the Euclidean distance is not considering the correlation of different criterion, and thus can hamper judgements consistency.

$\forall s_j \in S, \forall i \in \{1, \dots, N\}, p_{ji} = w_i \times s_{j,i}$ , with  $p_{j,i}$  being the normalized weighted performance of solution  $s_j$  for criterion  $i$ ;  $I_1$  is the set of criteria beneficial for the solutions and  $I_2$  the set of criteria disadvantageous for the solutions. The positive ideal solution  $s^+$  and negative ideal solution  $s^-$  are calculated such as:

$$s^+ = \{s_1^+, \dots, s_j^+\} = \left\{ \left( \max_i p_{j,i} \mid i \in I_1 \right), \left( \min_i p_{j,i} \mid i \in I_2 \right) \mid j \in \{1, \dots, J\} \right\} \quad \text{Eq. 75}$$

$$s^- = \{s_1^-, \dots, s_j^-\} = \left\{ \left( \min_i p_{j,i} \mid i \in I_1 \right), \left( \max_i p_{j,i} \mid i \in I_2 \right) \mid j \in \{1, \dots, J\} \right\} \quad \text{Eq. 76}$$

The Euclidian distance of each solution to  $s^+$  and  $s^-$  are calculated such as:

$$\forall j \in \{1, \dots, J\}, s_j^+ = \sqrt{\sum_i (p_{j,i} - s_j^+)^2} \text{ and } s_j^- = \sqrt{\sum_i (p_{j,i} - s_j^-)^2} \quad \text{Eq. 77}$$

Which enables to calculate for each solution the so-called similarities to the positive-negative solution:  $C_j^+ = \frac{s_j^-}{s_j^+ + s_j^-}$  and then rank the solutions in a descending order by similarities.

TOPSIS method is used for airlines failure risks measurements (Du *et al.*, 2023), airlines efficiency measurements (Barros and Wanke, 2015; Wanke *et al.*, 2015) or even on strategic alliance between airlines (Garg, 2016). (Dožić, 2019) reported multiple utilization of the TOPSIS method for airlines competitiveness measurements, service quality evaluations, aircraft selections or even safety evaluations.

This necessitates knowing all the alternatives to enable the calculations of the positive and negative ideal solutions and bring a result. This is not usable in our case as the optimizer is assessing at each iteration the solutions produced but TOPSIS could support efficiently the choice within a finite set of alternatives.

#### 5.1.1.4. Analytic Hierarchy Process (AHP)

The Analytic Hierarchy Process (AHP) method enables the decision-makers to identify the right weight for each criterion to then proceed to a weighted sum of the performance of each criterion. Presented by (Saaty, 1982), the AHP proposes to the decision-makers to organize the criteria in an hierarchical tree with sub-criteria belonging to a criteria group (as represented in color in Figure 11 for our case). Let us note  $L$  the set of groups of criteria, indexed by  $l$ . We note  $E$  the set of experts answering the AHP Questionnaire group vision, indexed by  $e$ . The decision-makers provide pairwise comparisons (see Eq. 78, p.80) based on Saaty's scale between criteria of a same group (see Table 6). This corresponds to fill in the matrix  $M_{l,n}$ , with  $l \in L$ , with  $n$  criteria to compare, belonging to the same group of criteria  $l$ .  $M_{l,i,j}^e$  is the importance given by expert  $e \in E$  for criterion  $i$  relative to the criterion  $j$ .  $M_{l,i,i}$  is always equal to 1 as one criterion cannot have a higher or lower importance than its own importance. Due to the pairwise comparison, we have  $M_{l,i,1}^e = \frac{1}{M_{l,1,i}^e}$ .

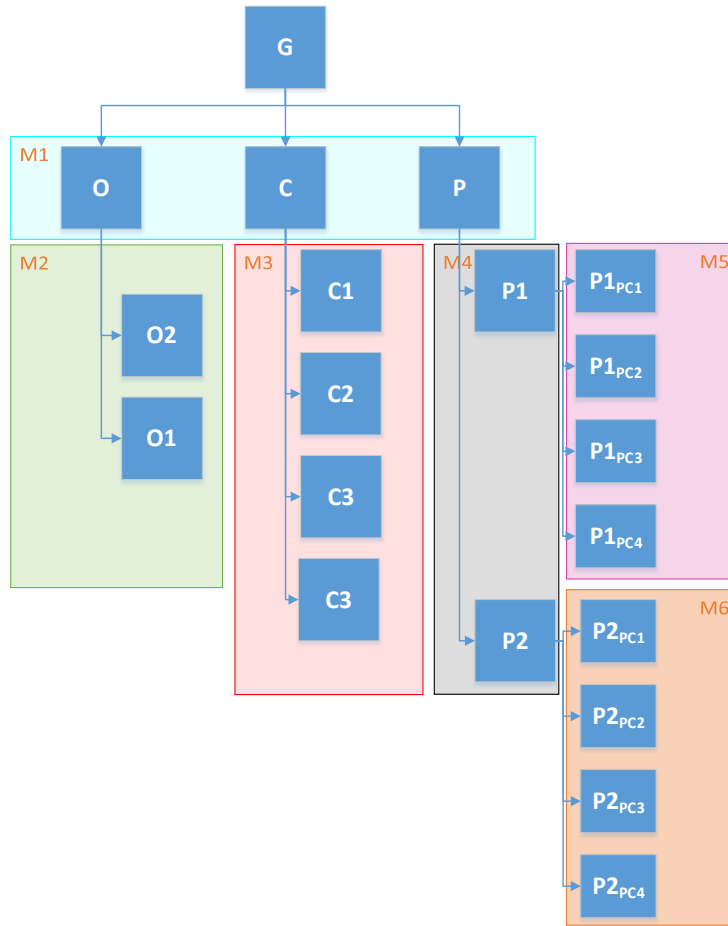

Figure 11: Simplified AHP Tree with matrices gathering the pairwise comparison.

Table 6: Saaty's scale (Saaty, 1987) showing the Intensity of importance on an absolute scale.

	Definition	Explanation
1	<b>Equal importance</b>	Two activities contribute equally to the objective
3	<b>Moderate importance of one over another</b>	Experience and judgment moderately favor one activity over another
5	<b>Essential or strong importance</b>	Experience and judgment strongly favor one activity over another
7	<b>Very strong importance</b>	An activity is strongly favored, and its dominance demonstrated in practice
9	<b>Extreme importance</b>	The evidence favoring one activity over another is of the highest possible order of affirmation

$$\forall l \in L, \forall e \in E M_l^e = \begin{pmatrix} 1 & \dots & M_{l,n}^e \\ \dots & \dots & \dots \\ M_{l,n,1}^e & \dots & 1 \end{pmatrix} \quad \text{Eq. 78}$$

For a group decision, (Saaty, 1989) recommends to use the geometrical mean to gather all the experts inputs together. We note  $M_{l,i,j}^g$  the group vision of the importance of criterion  $i$  towards  $j$  in Eq. 79.

$$\forall i, j \in \{1, \dots, n\}, M_{l,i,j}^g = \left( \prod_{e \in E} M_{l,i,j}^e \right)^{\frac{1}{\text{Card}(E)}} \quad \text{Eq. 79}$$

Given that the sub-(sub-)criteria are compared pairwise, the decision-makers answers must respect a minimum level consistency. Thus, if criterion  $C_1$  is preferred twice to criterion  $C_2$ , which is preferred twice to criterion  $C_3$ , criterion  $C_1$  must be preferred four times to criterion  $C_3$ . To verify this consistency in the expert's answers in each group of criteria, a consistency ratio ( $CR$ ) is calculated and must be lower than or equal to 10% (Saaty, 1987).

From each comparison matrix for each (sub-) category of criteria, a priority vector  $P$  is calculated, in order to get each criterion weight corresponding to the decision-maker evaluation (Saaty, 1987). Three steps are necessary to extract the priority vector  $P$ :

- Normalization of the matrix by column:

$$\forall l \in L, M_l^{Norm} = \begin{pmatrix} \frac{1}{\sum_i C_{i,1}} & \dots & \frac{C_{1,n}}{\sum_i C_{i,n}} \\ \dots & \dots & \dots \\ \frac{C_{n,1}}{\sum_i C_{i,1}} & \dots & \frac{1}{\sum_i C_{i,n}} \end{pmatrix} \quad \text{Eq. 80}$$

- Sum of each row to obtain a vector:

$$\forall l \in L, \forall i \in \{1, \dots, n\}, P_{l,i}' = \sum_j M_{l,j,i}^{Norm} \quad \text{Eq. 81}$$

- Normalization of the vector obtained from previous steps:

$$\forall i \in \{1, \dots, n\}, P_{l,i} = \frac{P_{l,i}'}{n} \quad \text{Eq. 82}$$

This gives us the priority vector  $P_l = \begin{pmatrix} P_{l_1} \\ \dots \\ P_{l_n} \end{pmatrix}$ : each component is the weight of the corresponding criteria in the considered matrix  $M_l$ .

In a complete AHP, the alternatives proposed are also compared two by two for each criterion to enable the complete alternatives evaluation. A major advantage of the AHP is that different decision-makers can discuss and agree on the hierarchical tree, as well as fill in the pairwise comparison. As an increasing number of criteria and alternatives increase tremendously the number of inputs needed by the decision-makers, an incomplete AHP getting only the priority vectors of each criteria enables an efficient way of getting a group compromise on the importance weight of each criterion while limiting the number of inputs needed. Therefore, the AHP is very well suited to a group evaluation of numerous multi-criteria solutions. However, one must ensure that the criteria are independent of each other, as the AHP method is not able to properly handle criteria interdependency. Analytic Network Process (ANP) is an extension of the AHP process, presenting the criteria with a network view instead of a hierarchical view (Saaty, 2004). This releases the requirement for independent criteria. However, ensuring a clear network definition and answering all questions can be quite complex and time-consuming. Additionally, (Gu *et al.*, 2018) reports that a large number of indicators lead to unwieldy model. As a method for a group of experts must be transparent and easily usable, AHP is preferred to ANP in multi-criteria optimization with the need for a group view.

The AHP (pure AHP or combined with other methods) within the airline industry context was applied for supports on strategy decision such as the corporate social responsibility (Karaman and Akman, 2018), digital transformation strategies (Büyükozkan *et al.*, 2021) or customer satisfaction measurements (Yalcin Kavus *et al.*, 2022). It is also used for aircraft choice (Ardil, 2022), also in combination with TOPSIS (Kiracı and Akan, 2020), or Enterprise Resource Planning (ERP) system selection for airlines (Kilic *et al.*, 2014). The use of AHP to identify the right weights due to the high number of criteria, combined with TOPSIS method to get a ranking of suppliers appeared to be quite fruitful thanks to the strengths of the two methods. ANP appears also for outsourcing provider decision (Hsu and Liou, 2013). (Dožić, 2019) reported numerous AHP and ANP applications to routes selection, service quality measurements and improvements identification, competitiveness evaluation, aircraft choice as well as risk assessment. AHP seems to be the most commonly use method by airlines for many types of purposes.

### 5.1.2. MCDM Outranking Methods

#### 5.1.2.1. Preference Ranking Organization Method for Enrichment Evaluation (PROMETHEE)

PROMETHEE is an outranking method which was proposed initially by (Brans and Vincke, 1985) based on the extensions of the criterion notion. Instead of a simple numeric comparison, the notions of preference and indifference threshold enable different categories of criterion. Let  $s_{j,i}$  and  $s_{k,i}$  be the performances of solutions  $s_j$  and  $s_k$  for criterion  $i$ ,  $d_i$  the indifference threshold,  $p_i$  the preference threshold and  $P_i(s_j, s_k)$  the preference function for the criterion. Different criteria exist such as usual criterion, quasi criteria, criteria with linear preference, etc. Mathematical definitions and explanations can be found in the literature (Brans and Vincke, 1985).

The preference index is noted  $\pi(s_j, s_k)$  and is calculated such as:

$$\pi(s_j, s_k) = \sum_{i=1}^N w_i \times P_i(s_j, s_k) \quad \text{Eq. 83}$$

A valued outranking graph  $G$  is composed by the solutions such as one solution is a node, the arc between two nodes  $s_j, s_k$  has the value  $\pi(s_j, s_k)$ , which enrich the original notion of dominance graph.

The outgoing flow  $\Phi^+$  and the incoming flow  $\Phi^-$  of a node can be calculated from the preference indexes and provide the net flow  $\Phi$ . The outranking follows the two rules:

*If  $\Phi(s_j) > \Phi(s_k)$  then  $s_j$  outranks  $s_k$*

*If  $\Phi(s_j) = \Phi(s_k)$  then  $s_j$  is indifferent to  $s_k$  (same rank)*

The PROMETHEE method is easy to calculate and might be understandable for decision-makers who are familiar with pseudo-criteria concepts. It enables flexibility and human sensitivity modeling with the indifference and preference threshold. PROMETHEE were applied in comparison with the AHP for Boeing strategy (Haddad *et al.*, 2020). Otherwise, most of the application of the PROMETHEE methods were published for transportation use-case other than airlines-related (Yannis *et al.*, 2020). Worth to note is that no scientific publication with PROMETHEE airlines are presented by (Dožić, 2019), but PROMETHEE II



were applied in combination with AHP for environmental impact evaluation of the ATM, as well as for a location selection for military stakeholders.

However, while PROMETHEE works very well on strategical choices, such as a choice on different static alternatives, it is not suited for optimization problems: the optimizer cannot rely on human inputs at each iteration. Moreover, operational experts are not used to different types of criteria. While some notions such as the indifference threshold and preference threshold can be easily introduced, a full comprehension of the PROMETHEE method might require some time and the users trust in the system might be endangered. Additionally, this method is expensive in computation time on large-scale problems. Therefore, the PROMETHEE method is not adequate for a quick and efficient solution assessment, as required in the task P3 for a group optimization (see Figure 10).

#### 5.1.2.2. Elimination and Choice Expressing Reality (ELECTRE)

ELECTRE methods as described in (Roy, 1991) are outranking methods taking into consideration uncertainty, imprecision and inaccurate determination of performances. If globally a solution  $s_j$  is at least as good as another solution  $s_k$ , noted  $s_j S s_k$ , except on one criterion  $i$  (discordant criterion), ELECTRE methods are considering its importance coefficient  $w_i$  and introduce a concept of veto threshold  $v_i$ . It calculates from that a concordance index  $c(s_j, s_k)$  (how much the assertion “noted  $s_j S s_k$ ”, is true) as the addition of  $c_1(s_j, s_k)$  – the concordance index for all criteria in favor to this assertion – and  $c_2(s_j, s_k)$  – the concordance index for all criteria reflecting an hesitation ( $s_{j,i}$  indifferent with  $s_{k,i}$ , noted  $s_k I s_j$ ) or a contrary opinion ( $s_{k,i} S s_{j,i}$ ). This leads to the calculation of a discordant index.

As from these outranking relations, the goal is to select a set as small as possible of solutions offering the best compromise. Many variations of the ELECTRE methods were introduced, and the one proposing a ranking at the end of the procedure are ELECTRE II, III and IV while ELECTRE TRI for example tackles the sorting problem.

ELECTRE TRI application is presented by (Liu *et al.*, 2023) in combination with TOPSIS for classifying failure mode of aircraft power supply system. (Dožić, 2019) reported also ELECTRE application combined with other MCDM methods for aircraft selection as well as a few evaluations of service quality for airports application.

These ELECTRE outranking methods have a complex logic, which is complicated to explain in a simple way, and can be unclear for decision-makers, as well as necessitates a quite good

knowledge of the available data and numerous technical parameters setting. Moreover, as the PROMETHEE methods, the computational complexity is high and unsuited for large-scale problems. Therefore, ELECTRE based method seems inadequate for the performance assessment of all solutions proposed by the optimizer for a multi-airline operations problem.

### *5.1.3. Conclusion*

Multiple airlines involved in the decision-making means conflicting opinions on the importance of given indicators. A consensus among all stakeholders must be reached on the relations between the indicators. Thus, MCDM methods seems more adequate than multi-objective approaches (see section 3.1.3).

In airlines operations, it is mandatory to translate the decision-makers preferences as accurately as possible for a group vision. However, the optimization process cannot be stopped nor rely on human inputs, as multiple solutions must be evaluated and that the process must be quite time efficient (ideally 2 minutes and up to 5 minutes of computing time considered as acceptable by the users). Thus, the solution assessment during the optimization must be fully automated and necessitates a pre-defined evaluation function of the solutions. Outranking methods such as PROMETHEE and ELECTRE do not suit this requirement and cannot be used for optimization purposes.

An understandable logic behind the optimizer solutions evaluation phase is required and must be closely linked to the decision-makers preferences and sensitivity. While the TOPSIS method is proposing a very interesting approach of comparing the solutions with the positive ideal one and the negative ideal one, the computational time can be also a limiting factor, especially on a large-scale optimization as foreseen for the task P3 for the group optimization (on Figure 10, p. 73). Therefore, an aggregative method with weight definition involving all stakeholders seems the most promising approach.

The weights must be consistent with the different decision-makers reasoning on a group vision and must be robust enough to be used in several situations through an operational season (6 months). Using the AHP method to define a common and well-structured indicators tree and to calculate the group weights based on all the stakeholders' opinions seems quite relevant. The pairwise comparison of the criteria can be updated independently by each airline to reflect any change of perspective on the group business priorities. The AHP method has been already widespread used successfully within the airline industry for different choices and evaluations. The clear steps to calculate the group weights considering all stakeholders' perceptions

presents it as a good candidate for a transparent and widely accepted solutions evaluation process.

## 5.2. Application of the AHP Method for the Airlines Group

This section presents the AHP methods adapted for the group approach in our multi-airline operations optimization problem.

### 5.2.1. Hierarchical Criteria Tree Identification for the Industrial Use-Case

The goal of this multi-criteria evaluation is to find the most optimal solutions with a group vision. It is mandatory to maintain a given diversity in these optimal solutions, to allow afterwards that different optimal solutions are proposed to the decision-makers for the consensus identification.

A set of seven operational experts from different airlines of the Lufthansa Group, all working in the operations with a group component (by either projects, processes, or innovation for the airline group), accepted to participate to the identification and validation of the criteria and structure of the AHP tree for the global vision. The first part took place as a brainstorming about the criteria to consider and ensure a good quality of the solutions global assessment proposed by the optimizer. A second part consisted in the validation of the final AHP tree, following Saaty’s method. Numerous interviews (per email or video calls) took place and enabled to validate the following AHP criteria tree for the group global vision (Figure 12):

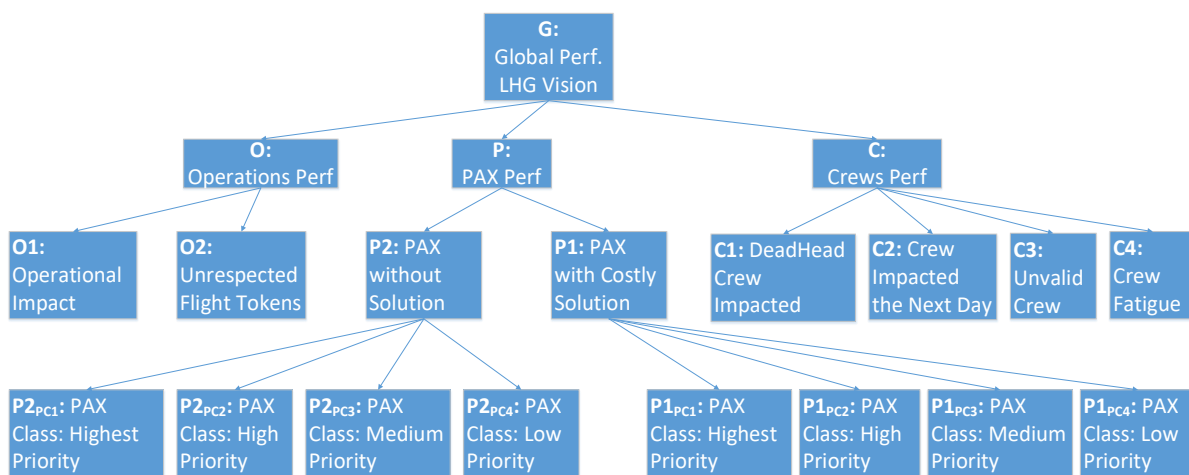

Figure 12: Hierarchical Criteria Tree developed with Experts from five different airlines<sup>9</sup>

Each sub-criteria identified and agreed in the AHP tree is formulated mathematically in section 4.5. The three main categories (Operational, Passengers related, and Crews related indicators) are quite standard in optimization and correspond to the three main pillars of recovery problem

<sup>9</sup> This hierarchical criteria tree can be found in a better resolution in Appendix B.

found in the scientific literature (see chapter 2). The sub-categories rely on the experts' experience as well as trade-off of criteria that can be calculated for all airlines. Having the right data of all airlines in a common system is already a challenge that might last for a couple of years. Thus, the criteria must be smartly defined so that it is calculable for all airlines and defined on data that are commonly used in each Operations Center.

The breakdown of the passenger sub-criteria into four different types, relying on booking class but also special statuses such as VIP, HON-circle members or airline staffs (see the definitions in section 3.1.2 and 4.1.5) enables an assessment of the solutions on a granularity that emphasize some categories more than others, depending on the group business strategies (definition of the passenger criteria in section 4.5.2).

The crew rules being highly complex and different in each airline, the group optimization would not even try to optimize crew rotations nor assignments (see section 3.1.2). It simply aims at monitoring the impact of new schedule on crews, to translate into the global solution assessment the crew friendly (or unfriendly) solutions, and the knock-on impact that could be expected from crew issues (definition of the crew's criteria in section 4.5.3).

The operational criteria also define in a smart manner the operational impact of a solution according to the commonly available data. Through a pre-processing step enabling the calculation of so-called *Last Time Of Touchdown (LTOT)* each flight is assigned a time at which it must land before spreading knock-on delay on the network. Calculating each delay configuration on the other aircraft rotations and crew connections would require a high volume of data as well as additional computing time for the solution evaluation. This is why it is as a pre-processing step (definition of the operational criteria in section 4.5.4).

As one of the major requirements of the AHP, the set of criteria defined with the experts are all considered independent. Indeed, the three main categories (operations, passengers, and crews) are clearly independent of each other. Within the sub-categories, the two operational criteria are not assessing the same aspect of the operations, and the two aspects are considered unrelated (albeit the tokens allocated by the users might be linked with some potential operational impact, it is an additional information that no data can bring and that only a priority setting through tokens allocated by the experts can provide). This is also true for the crew criteria and the passenger criteria. The four crew indicators are each measuring a different and independent aspect of the crew impact, and the different categories of passenger sub-criteria (with costly solutions and without solutions) are clearly not dependent. The very clear

categorization of the passenger according to their booking class and statuses also guarantee that no interdependency exists between the sub-criteria.

Each stakeholder representing an airline in the group decision must fill in the questionnaire, with a strategic vision for the group. The UI, developed for the AHP questionnaire filling in process, is offering interactive sliders to move according to the pairwise comparison between two criteria. Figure 13 shows the start page of the AHP questionnaire for the group vision.

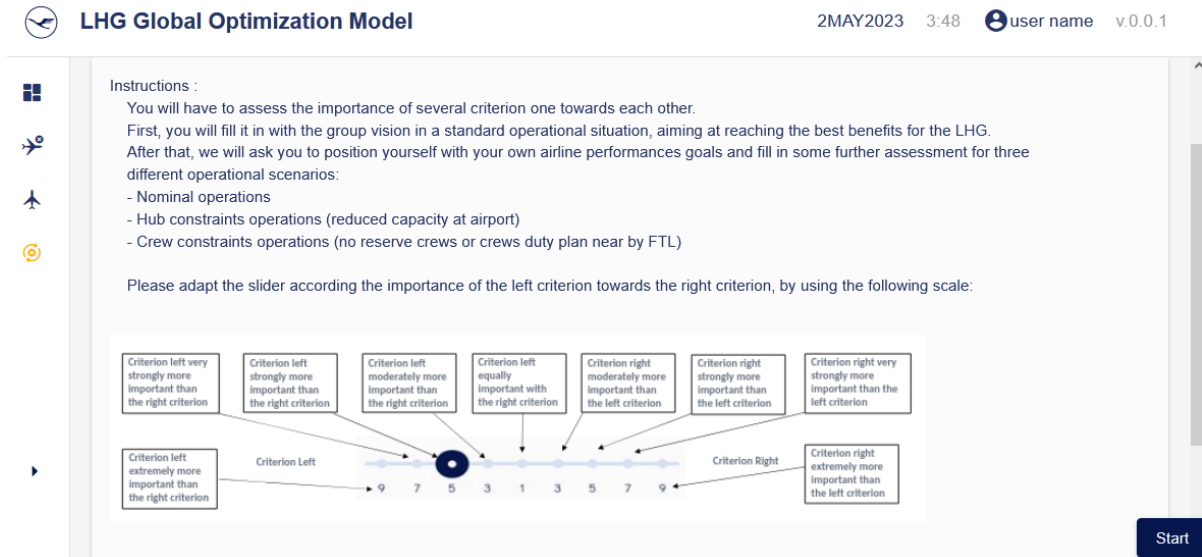

Figure 13: User Interface developed to get the users pairwise comparison.

## 5.2.2. Multi-Stakeholder AHP Applied to the Industrial Use-Case

### 5.2.2.1. Weights Calculation

From each comparison matrix for each (sub-) category of criteria, a priority vector  $P$  is calculated, in order to get each criterion weight corresponding to the decision-maker evaluation (Saaty, 1987) (see section 5.1.1.4).

As defined in section 4.5,  $D$  is the set of sub-criteria defined in the AHP Tree, indexed by  $d$ :

$$D = \{P1_{PC1}, P1_{PC2}, P1_{PC3}, P1_{PC4}, P2_{PC1}, P2_{PC2}, P2_{PC3}, P2_{PC4}, C1, C2, C3, C4, O1, O2\}$$

We also define:

$w_d$  Weight calculated for criteria  $d$  for the global vision in nominal operations, based on all airlines' answers in their AHP questionnaires.

$rw_i$  Relative weight of criteria  $i$  in the considered matrix.

Each indicator is belonging to a “path” of matrices with three levels maximum due to the AHP tree structure (three levels for the passenger ones, two for the crews and aircraft ones). Therefore, we have for each indicator at the last level of the tree:

- For the operational indicators:

$$\forall d \in \{O_1, O_2\}, w_d = rw_O \times rw_d \quad \text{Eq. 84}$$

- For the crew indicators:

$$\forall d \in \{C_1, C_2; C_3, C_4\}, w_d = rw_C \times rw_d \quad \text{Eq. 85}$$

- For the passengers indicators:

$$\forall d \in \{P1_{C1}, P1_{C2}, P1_{C3}, P1_{C4}\}, w_d = rw_P \times rw_{P1} \times rw_d \quad \text{Eq. 86}$$

$$\forall d \in \{P2_{C1}, P2_{C2}, P2_{C3}, P2_{C4}\}, w_d = rw_P \times rw_{P2} \times rw_d \quad \text{Eq. 87}$$

#### 5.2.2.2. Consistency Ratio

In order to calculate the consistency ratio, the eigenvalue  $\lambda_{max}$  of matrix  $M$  (size  $n \times n$ ) is necessary (Saaty, 1987, p. 11).  $\lambda_{max}$  respects:  $\lambda_{max} \geq n$ . In case of perfect consistency of the matrix  $M$ ,  $\lambda_{max} = n$ .

The Consistency Index ( $CI$ ) and Consistency Ratio ( $CR$ ) are defined as:

$$CI = \frac{\lambda_{max} - n}{(n - 1)} \quad \text{Eq. 88}$$

$$CR = \frac{CI}{RCI} \quad \text{Eq. 89}$$

$RCI$  is a random consistency index, which is given by (Saaty, 1987) and depends of the number of total “end-criteria” (see Table 7).

*Table 7: Random Consistency Index according to the size of the matrix, proposed by Saaty in 1987*

N	1	2	3	4	5	6	7	8	9	10
RCI	0	0	0.58	0.90	1.12	1.24	1.32	1.41	1.45	1.49

### 5.2.3. Illustration on a Real Use-Case

Let us illustrate the application of the multi-stakeholder AHP to calculate the group crew criteria weights. This corresponds to the matrix M1 and M3 from Figure 11. While experts from seven airlines participated to the definition and validation of the hierarchical tree of indicators, the questionnaires were filled for only four airlines. The questionnaires for the three other airlines for which no experts were available are filled in with default values.

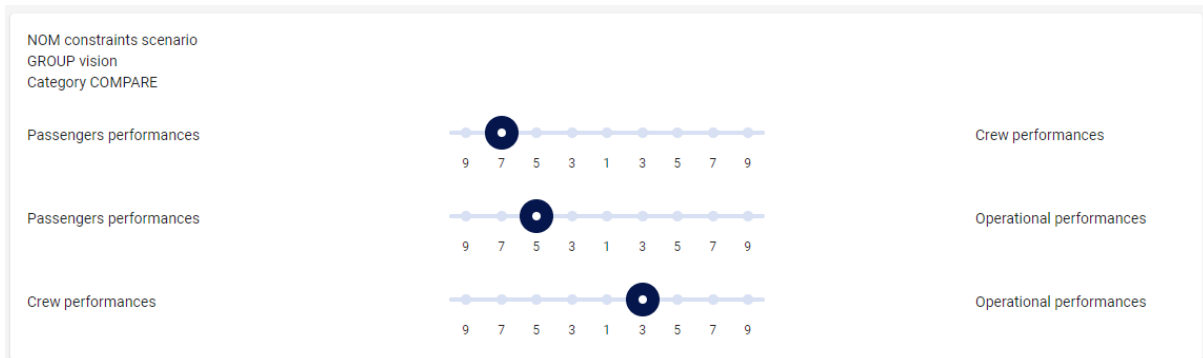

Figure 14: Answers provided by the Expert 1 and 4 for the group vision (M1).

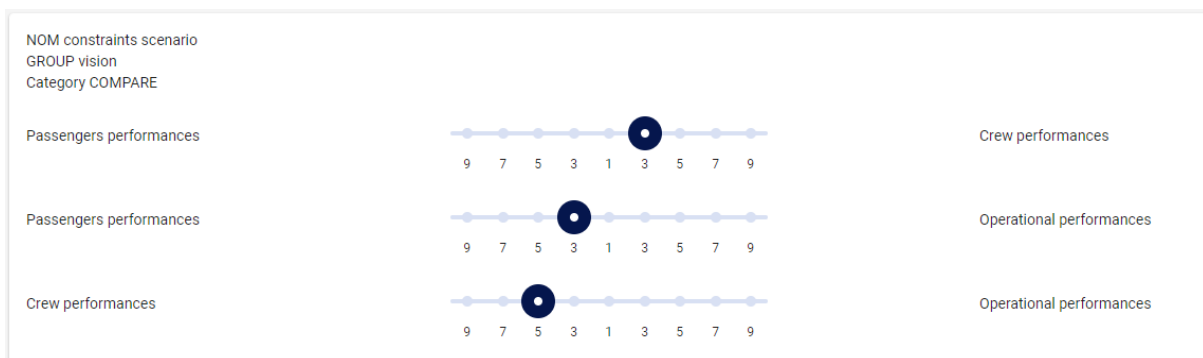

Figure 15: Answers provided by the Expert 2 and 3 for the group vision (M1).

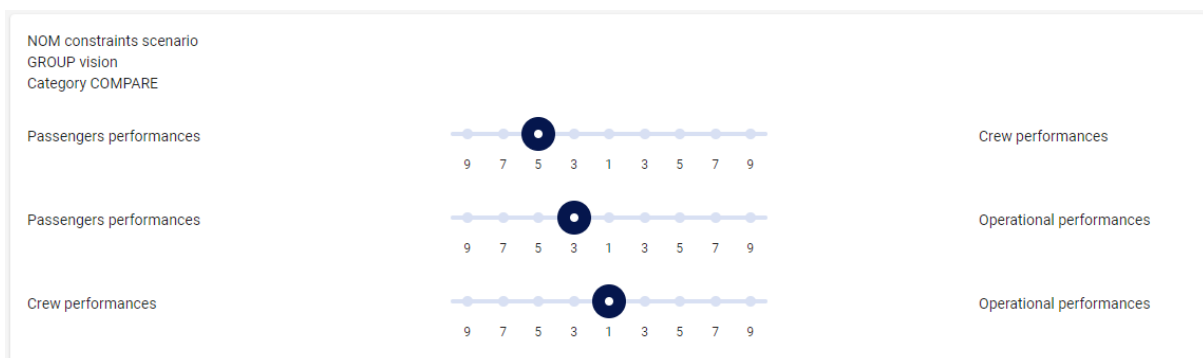

Figure 16: Default values all other airlines for which no expert was available (M1).

The equations Eq. 79 and Eq. 80 (p. 81) provide us the following group M1 matrix normalized  $M_{M1}^{g'}$ :

Table 8: Group normalized matrix for the level M1.

Level M1	Operations	Crew	Passenger
Operations	0.1777	0.1963	0.1713
Crew	0.2056	0.2271	0.2342
Passenger	0.6167	0.5766	0.5946

Which is leading to the priority vector through the equations Eq. 81 and Eq. 82 (p. 81):

$$P_{M1} = \begin{pmatrix} 0.1817 \\ 0.2223 \\ 0.5960 \end{pmatrix} \begin{matrix} \text{Operations} \\ \text{Crew} \\ \text{Passenger} \end{matrix}$$

The same applies for the matrix M3, with the following answers from the experts (see Figure 17). The equations Eq. 79 and Eq. 80 (p.81) provide us the following group M3 matrix normalized  $M_{M3}^{g'}$ :

Table 9: Group normalized matrix for the level M3.

Level M3	C1 (deadhead impact)	C2 (impact next day)	C3 (invalid crew)	C4 (crew fatigue)
C1 (deadhead impact)	0.2763	0.2562	0.2895	0.2850
C2 (impact next day)	0.2763	0.2562	0.2447	0.2463
C3 (unvalid crew)	0.3198	0.3507	0.3350	0.3372
C4 (crew fatigue)	0.1275	0.1368	0.1306	0.1314

Which is leading to the priority vector through the equations Eq. 81 and Eq. 82 (p. 81):

$$P_{M3} = \begin{pmatrix} 0.2768 \\ 0.2559 \\ 0.3357 \\ 0.1316 \end{pmatrix} \begin{matrix} \text{C1 (deadhead crew impact)} \\ \text{C2 (impact next day)} \\ \text{C3 (unvalid crew)} \\ \text{C4 (crew fatigue)} \end{matrix}$$

Following equation Eq. 85 (p. 89), we therefore get the following weights for the group crew criteria:

$$\begin{pmatrix} w_{C1} \\ w_{C2} \\ w_{C3} \\ w_{C4} \end{pmatrix} = \begin{pmatrix} 0.0615 \\ 0.0569 \\ 0.0746 \\ 0.0292 \end{pmatrix}$$



## Part III. Multi-Stakeholders Decision Making and Long-Term Equity Method

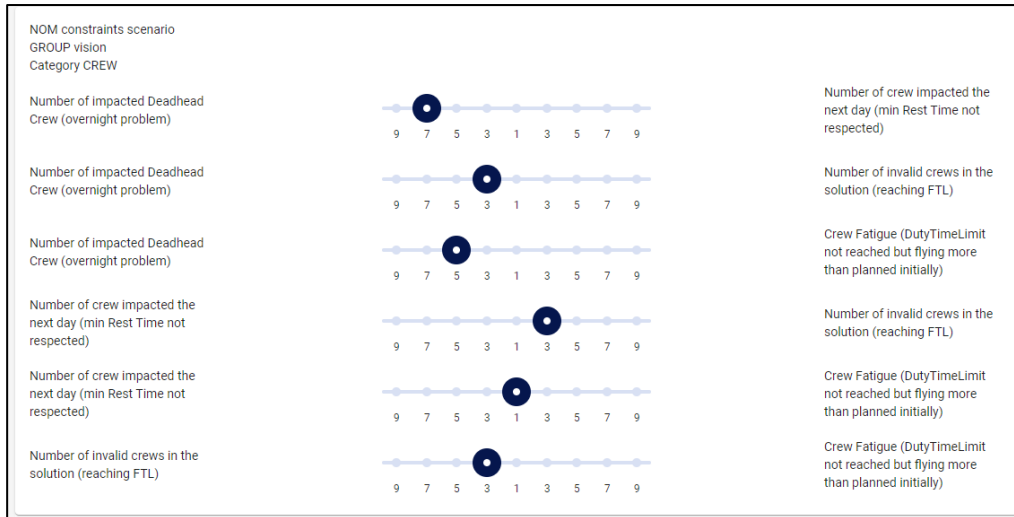

Figure 17: Answers provided by the Expert 1 and 4 for the group vision (M3).

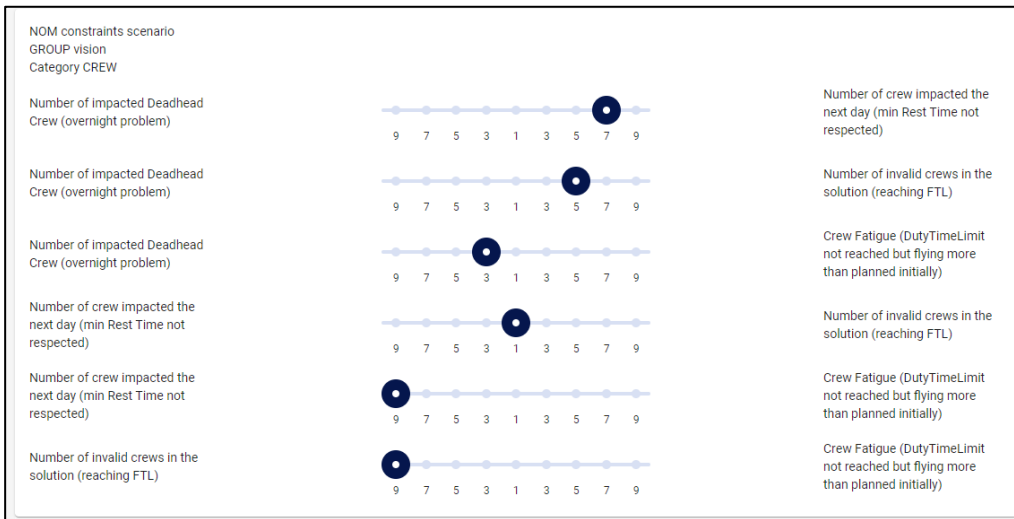

Figure 18: Answers provided by the Expert 2 and 3 for the group vision (M3).



Figure 19: Default values for all other airlines for which no expert was available (M3).

This example illustrates the calculation for the crew criteria weights, from the priority vector calculated for the crew versus the operational and passenger related criteria times the priority vector of each of the dedicated crew criteria. One can remark that the evaluation with the group vision of the objective is spitted into two main categories: 2 experts out of 7 emphasize the passenger importance while 2 other experts emphasize the crew impact. Another split is observed for the crew indicators themselves, 2 experts emphasizing the impact on deadhead crews while 2 other experts emphasize the impact on the operations (on the same day through invalid crews and on the next day). This shows that the group vision is still influenced very much by the operational expertise of the hub operations. Experts 1 and 4 are operating from hubs with a strong focus on passengers while experts 2 and 3 are operating from hubs where one of the main challenges comes from the crews (tight number of crews and/or tight schedule of the crew near their duty time limits).

The group weights proposed by the multi-stakeholder AHP reflect quite accurately these two aspects and present a good compromise between all the experts' views.

### **5.3. Chapter Conclusion**

This chapter aimed at proposing a multi-stakeholder methodology for assessing in a time efficient manner all the solutions that could be found by the optimizer. As the optimizer is proposing new schedules of flights with delays, cancellations and accordingly the rebooking of the passengers, the solution assessment must be very fast to enable the optimizer to browse the search space. As explained in section 3.1.3 and defined in section 4.5, different indicators were defined with all operational experts involved. Since the solution assessment must represent the group vision on the solution, a multi-objective approach is not considered suitable, as the relationship between the objectives is not representative of the group consensus.

Therefore, a literature review on the multi-criteria decision-making (MCDM) method is proposed in section 5.1. While the outranking methods are very interesting thanks to their flexibility in expressing experts' preferences, their expensive computing time does not enable an intensive use for reviewing all solutions found by the optimizer in the solution space. From the aggregative methods reviewed, TOPSIS requires a knowledge of all solutions to fully use its potential, as well as quite some computational time. However, the Analytic Hierarchy Process (AHP) presents a well-designed method to calculate the relationship between each indicator, based on the inputs of multiple stakeholders. This method was successfully applied in many research fields, including airline industry for strategical choices.

The AHP presents three interesting strengths for the multi-airline operations optimization problem. Firstly, the AHP proposes a questionnaire on the indicators structure (pairwise comparisons), that the experts can fill in independently of any disruption, through a dedicated and intuitive user interface (UI). All experts should fill in or update the questionnaire at least once per season as from its airline's strategy and sensitivity, but one airline could also easily adjust its answers at any time if its business priorities change. Secondly, the AHP consolidates consistently multiple stakeholders' views in a group assessment of the indicators' weights. The method is easily explainable and understandable. Thirdly, the integrated consistency check is also a strong feature of the multi-stakeholder AHP to ensure the users trust in the group weights definition. The multi-stakeholder AHP method and its application are presented in section 5.2. Experts representing four airlines filled in the AHP questionnaire while defaults values were given for the three last airlines and the aggregated weights are satisfying.

This chapter proposed a method to evaluate the solutions browsed by the optimizer defined in chapters 8 and 9, as illustrated in task P3 (Figure 10). The next chapter aims at proposing a process to help the different airlines' users to assess the best solutions found by the optimizer (task P4 on Figure 10), and to elect the solution to implement together (task P5 on Figure 10).

## 6. Multi-Stakeholder Consensus Approach

From the optimizer process (P3 on Figure 10, p. 73), a couple of solutions are proposed to the users. These are the ones found if the optimizer did not completely converge towards the optimum (due to limited computing time). A simple approach could pick the solution with the best group performances, calculated through the macro-indicator with the group AHP weights. However, the impact of each solution on each airline can be very different. One solution could advantage an airline while another one could heavily affect its operations. In addition, due to the simplifications presented in chapter 4 to enable an appropriate and feasible group optimization, the full granularity of the data is not considered in the optimizer. Some information or data might lack in the system, and each instance of optimization is different. Therefore, a consensus on the solution to implement requires a coordination among all decision-makers to determine the preferred one (or less disliked one).

Thus, the users of each airline must review the proposed solutions and express their preferences (P4 on Figure 20). It might be difficult for an operational expert to assess the complex impact of each solution on its operations through the different indicators and data. A support in the ranking must thus be proposed, catching the subtleties of each airline.

**Requirement 6.1:** The requested inputs shall be limited to the necessary inputs from the user to model its sensitivity and subjectivity: a standard MCDM method requires user's inputs about his preferences and sensitivity. However, the requested inputs shall be limited (~2 minutes) to avoid time-consuming process (as the user deals in parallel with the daily operations).

For this reason, a complete AHP is not an option, as it necessitates pairwise comparison of the solutions for each indicator. Once each airline ranked the solutions, a consensus process (P5 on Figure 20) shall identify the solution that is presenting the best compromise between all parties involved in the group decision-making process. It is important to involve the users actively in the consensus process, to build in the trust into the system. No complex calculations can thus be proposed as not easily and transparently demonstrable to the user.

**Requirement 6.2:** The ranking process and the consensus identification process shall be clear, transparent, and easily understandable.

As the long-term equity is a central piece for a group optimization, the task P5 shall incorporate a compensation mechanism if the history presents inequity. Therefore, P6 on Figure 20 calculates after each GOM instance the new long-term equity balance.

**Requirement 6.3:** To enable a compensation mechanism in case of historical inequity, it shall be possible to give more weight to one airline in the group ranking.

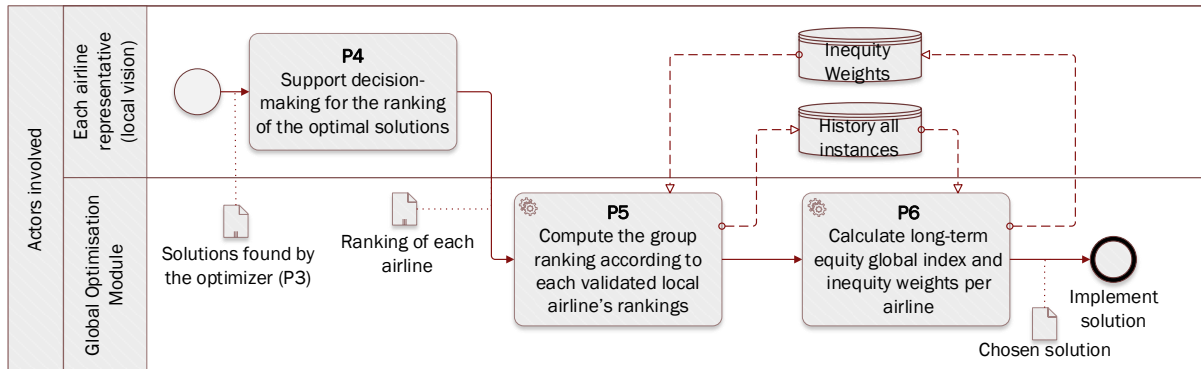

Figure 20: P4, P5 and P6 detailed Business Process Model and Notation chart to illustrate the consensus process.

This chapter is first reviewing different methods to support the solutions assessment and compromise process (section 6.1). The presentation and analysis of the approach chosen is then presented in section 6.2. This chapter was the subject of an article (Carré *et al.*, 2021a).

## 6.1. Literature Review on Multi-Stakeholders Consensus Identification

### 6.1.1. Group MCDM and Group Compromise Methods

Numerous technics were developed to aggregate non-additive performances. Some were presented already in the section 5.1. However, these methods (such as PROMETHEE or ELECTRE) necessitate many comparisons and preferences statements between the solutions. The users do not have much more than 2 minutes to provide the preferences while steering the daily operations, with all the related challenges (requirement 6.1). Therefore, more embedded methods should be proposed.

#### 6.1.1.1. Choquet Integral

Choquet Integral methods requires to know the interactions (which is a measure of the importance of the criteria, also called capacities (Choquet, 1954) or fuzzy measures (Sugeno, 1974)) of each criteria alone, and in exhaustive combinations for each subset of criteria ((Meng *et al.*, 2021) and (Corrente *et al.*, 2016)). Then, knowing the performances of the solutions on each criterion, the Choquet Integral computes a score for each solution, representing the performance of a solution on the n criteria.

Choquet Integral is used principally in preferences learning for better users' suggestions, for example on on-line shopping websites. It integrates well high volume of data to provide user's specific recommendations and suggestions. Some limitations to the Choquet Integral utilization are however reported by researchers, such as the fact that having more than two objectives and for each objective more than three criteria is increasing too much the amount of comparisons required (Terrien, 2018). Therefore, due to the high number of criteria in our problem, Choquet Integral seems not suitable to efficiently gather the airline's decision-maker inputs and support them in the decision-making process within the solutions proposed by the multi-airline operations optimizer.

### 6.1.1.2. Sugeno Integral

Sugeno integral (Sugeno, 1974) proposes a non-additive aggregation method. It is famous in supervised learning to identify and express rules sets for classification problems from multiple and sometimes imprecise evaluations (Brabant *et al.*, 2020; Dubois *et al.*, 2014).

The Sugeno integral allows to aggregate values that belongs to a same scale. It is known for behaving like the median of the normalized ratings per criteria considering the importance levels of the best satisfied criteria (Dubois *et al.*, 2014). Sugeno relies on ordinal numbers for satisfaction modeling, necessitates numerous inputs from the users to calibrate the parameters of the Sugeno Integral and to use it as a decision-making aid. Similarly to the Choquet integral, the Sugeno integral would take more than the 2 minutes allowed per user to fill in the decision-making system inputs. Moreover, it is very complicated to explain in a simple way the Sugeno and Choquet methodologies to users not having deep knowledge into the decision under uncertainties.

Decision under uncertainties is not relevant in our case as the user is the one providing the inputs and that the process necessitate a clear and understandable process. Therefore, a category of methods widely accepted are the ones from the social vote theory, which could support efficiently the users in their rankings and then the elicitation of the solution to implement with a group compromise.

### 6.1.2. Social Vote Theory

As mentioned before, the group decision must be a process that is intuitive, easily provable, and transparent for the users to build on their trust in the system. This leads to search for an approach, which must be quite simple (no complex calculations to be explained, as from

requirement 6.2) and easily acceptable by the users. Social vote theory technics might be well suited for our purpose.

A typical case of multi decision-makers is the election of representatives. Several methods were proposed and are still currently used, such as the majority (the candidate who received the most votes), two-rounds electoral system (first round selecting the two candidates with the most votes, and the second one selecting the candidate with more than 50% of votes), Condorcet Choice method or Borda count method (Anderson, 1994). In our context, a voter can be either a criterion (airline's ranking process) or an airline (group consensus process) and the candidates are the solutions.

#### **6.1.2.1. Condorcet Choice Method**

Condorcet Choice method (proposed in the XVIII century) proposes to count the times where the candidate A is preferred to candidate B. The candidate gathering the highest preferences amount is elected. For example, if:

- B is preferred 10 times over 19 to A,
- A is preferred 16 times over 19 to C,
- B is preferred 12 times over 19 to C.

Then B is elected, as it wins all its tournaments. However, several situations lead to a “no decision status”. For example, there is no clear preferred choice, if:

- A is preferred 5 times over 7 to B,
- B is preferred 5 times over 7 to C,
- C is preferred 4 times over 7 to A.

In a group consensus process, there is no possibility of a “no decision”, especially during operations. Thus, the Condorcet choice method might not be the most suited for our problem.

#### **6.1.2.2. Borda Count Method**

A famous method – especially in sports competitions – is based on scores. For each round,  $N$  candidates are attributed given number of points, as a function of their rank and performances. The points are linearly attributed according to their rank, the first one getting  $N - 1$  points, the second one  $N - 2$  points, etc. This is called the Borda count method. By summing the points

gathered for each round and ordering it decreasingly, one can easily obtain the corresponding ranking. This can be mathematically formalized as follows: let us note  $r_{i,k}$  the rank of alternative  $i$  given by the  $k^{\text{th}}$  voter. Borda points for alternative  $i$  is noted  $b_i$  and calculated as in Eq. 90.

$$b_i = \sum_k (N - r_{i,k}) \quad \text{Eq. 90}$$

One of the advantages of Borda count method is that two solutions can have the same rank if the decision-maker considers them equivalent. Moreover, Borda count method has a great advantage on Condorcet choice method: it is electing a winner whatever the situation is, in the contrary to Condorcet choice (Young, 1974). Some authors also propose to combine both methods to count the points related to how many times it beats the other solutions. This allows incomplete preferences through incomplete rankings to spare time to the users (Herrero and Villar, 2021).

As pointed out, one elector could rank two solutions as equivalent with the users' inputs. For two equivalent solutions, the same number of points should be attributed. As the two solutions are using the ranks  $k$  and  $k + 1$ , we apply the average score proposed by (Narodytska and Walsh, 2014) in the context of partial voting. Each solution thus will receive  $\frac{(n-k)+(n-(k+1))}{2}$  points. The solution ranked next to the two equivalent ones will get the standard Borda point attributed to its rank:  $(n - (k + 2))$ . This respects the decision-maker's sensitivity, ensures the respect of the total amount of Borda points distributed among the solutions by one elector as well as preserve the points allocated to any solution ranked after the equivalent solutions.

### 6.1.3. Conclusion

This section 6.1 proposed a complementary literature study presented in section 5.1. The outranking methods such as PROMETHEE and ELECTRE are necessitating too many inputs from the users, which is also the case for a complete AHP necessitating pairwise comparisons of the alternatives. Some methods such as the Choquet and Sugeno integrals are enabling to model uncertainties in the decision. However, they do require many inputs and are not easily understandable for neophytes in this field (contradicting the requirements 6.1 & 6.2). Among the other methods presented above, the TOPSIS method and the Borda count method (from the social vote theory) seems quite promising to fulfill the requirements.



The advantage of the TOPSIS approach is that no user inputs are required. However, this might also be a disadvantage, as the user sensitivity and subjectivity are not modelled nor considered. In a human assessment of solutions, some results can be considered equivalent even if numerically different. Moreover, some preferences for indicators exist, but no preferred interval of results considered as acceptable can influence the user choice. None of that is modelled nor easily integrated in TOPSIS method.

Therefore, the method used for the consensus identification can be based on a Borda count method, which is easily adaptable with quasi-criteria and pseudo-criteria. The social vote theory considers the solutions holistically and does not get limited to the performance gap between those. It can be also easily adapted to receive as inputs a mechanism to compensate any inequity of the history (requirement 6.3). This is explained more in details in 6.2.

## **6.2. Application of the Borda Count Method for the Group Consensus**

It is crucial to support the decision-maker in the solutions ranking thanks to a semi-automated process due to the complexity of the data, but the user must be able to edit the proposed ranking to influence it with their own operational sensitivity (requirement 6.1). Such a process will reduce the decision complexity for airlines users while ensuring a ranking capturing the subtleties of the local operations. The following sections present a two-stage method published in (Carré *et al.*, 2021a).

We consider in this problem that the decision-makers are having a rational behavior, which means that they are ranking the solutions according to their own benefits and drawback assessment but not to influence the vote results by voting in a manner that would favor their preferred solution. This is a very strong hypothesis, which is justified by the several facts. First, all airlines' representatives are aiming at the group benefits and the reduction of the disruption on their own operations, if equity is ensured. This can be guaranteed thanks to the introduction of a measurement of the long-term equity (P5.2 on Figure 20). If imbalances are spotted after several rounds of common optimization, one should introduce compensation mechanisms for the disadvantaged stakeholders, to help restoring equity balance (see chapter 7). Therefore, one stakeholder trying to gain more than the others would be twice penalized: by not reaching the best results of the group and by the compensation mechanism. This should incentive all stakeholders to aim for the group benefits. Secondly, no airline can be forced to participate, but the hypothesis being that it results in benefits for all on the long term, it is rather an opportunity.

Thirdly, a transparent monitoring of these collaboration rounds must be available to all stakeholders and objectively assess the respect of long-term equity as well as the global and local benefits in comparison to acting alone (baseline).

Based on these three assumptions and propositions, one can reasonably expect a rational behavior from stakeholders for a local assessment of the global optimal solutions, and this especially within a group of airlines, that are not competitors one towards the others. A decision-support method is proposed to enable a quick and efficient ranking for the user. Once all participants submitted their rankings, the system proposes the solution reaching a group consensus.

### 6.2.1. Threshold of Indifference and Acceptable Interval of Performances

To capture efficiently the decision-makers preferences, two inputs per criterion (see the definitions section 4.5) are asked: a threshold of indifference and an acceptable interval of performances. In this first Borda count application, each criterion is considered as a voter.

Let  $S$  be the set of solutions to rank indexed by  $s$ ,  $D$  be the set of criteria considered indexed by  $d$ . We note  $g_d(s)$  the performance and  $r_d(s)$  the rank of solution  $s$  for criterion  $d$ .

### 6.2.2. Indifference threshold

Defined by (Roy, 1991), for each criterion, an indifference threshold allows the system to model the following human behavior: two solutions with very similar performances for a criterion are considered equivalent for this criterion. We note  $q_d$  the indifference threshold for the criterion  $d$ .

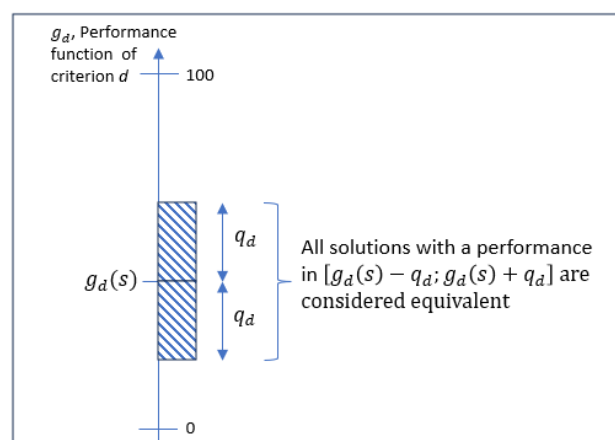

Figure 21: Illustration of the indifference threshold for a criterion  $d$ .

### 6.2.3. Acceptable interval of performances criterion per criterion

The decision-maker can indicate its preferred value of performance for a given criterion. This is an interval but can also be a specific value (lower bound = upper bound) or minimum/maximum threshold value (one of the lower or upper bound is the minimum or maximum of the performance for the given criterion). This enables that several solutions, which performances are contained in the acceptable interval, are all assigned on the first rank and equivalent for the given criterion. The major reason for this interval per criterion is the following situation: the disruption to optimize might take place in parallel to another local disruption for a participating airline. For example, if a capacity constraint takes place at the airline hub, this airline might be happy if a major part of its flights towards the disrupted virtual hub are cancelled and that its passengers are taken over by the other airlines. Therefore, the acceptable interval of performances for some criterion might be different from the expected one (maximum of benefits). This is illustrated on Figure 22. We note  $O_d = [O_d^-; O_d^+]$  is the acceptable performances interval for the criterion  $d$ , and  $dist(g_d(s) - O_d)$  the distance between the performance of solution  $s$  for criterion  $d$  towards  $O_d$ .

$\forall d \in D,$

$$\begin{aligned} dist(g_d(s) - O_d) &= \min_d(|g_d(s) - O_d^+|, |g_d(s) - O_d^-|, |g_d(s) - O_d^-|, |g_d(s) - O_d^+|) \end{aligned} \quad \text{Eq. 91}$$

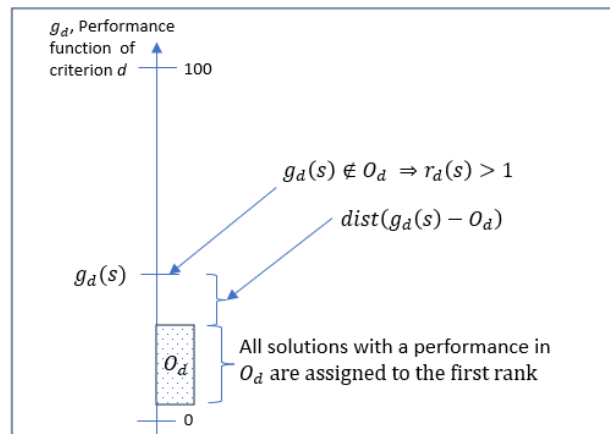

Figure 22: Illustration of the acceptable interval of performance for a criterion  $d$ .

### 6.2.4. Borda Score Ranking Method Applied to Local Rankings

The system works as follows: for each criterion (= one voter), a ranking is defined by:

- All solutions with performances within  $O_d$  get the first rank:

$$\forall d \in D, \forall s \in S, \text{ such as } g_d(s) \in O_d, \quad r_d(s) = 1 \quad \text{Eq. 92}$$

- For all other solutions:
  - If two solutions have equivalent performances according to the decision-maker, then they receive the same rank:

$$\forall d \in D, \forall s, s' \in S, g_d(s) \notin O_d \text{ and } g_d(s') \notin O_d, \quad \text{Eq. 93}$$

$$\text{If } |g_d(s) - g_d(s')| \leq q_d \text{ then } r_d(s) = r_d(s')$$

- If three solutions  $s, s'$  and  $s''$  exist such as  $s$  is equivalent with  $s'$ ,  $s'$  is equivalent with  $s''$  but  $s$  is not equivalent with  $s''$ , then  $s'$  is equivalent to the solution having the nearest performance (see illustration on Figure 23):

$$\forall d \in D, \forall s, s', s'' \in S, g_d(s) \notin O_d, g_d(s') \notin O_d, g_d(s'') \notin O_d, \text{ such as:}$$

$$\text{dist}(g_d(s) - O_d) \leq \text{dist}(g_d(s') - O_d) \leq \text{dist}(g_d(s'') - O_d)$$

$$|g_d(s) - g_d(s')| \leq q_d \text{ and } |g_d(s') - g_d(s'')| \leq q_d$$

$$|g_d(s) - g_d(s'')| > q_d$$

Eq. 94

$$\begin{cases} r_d(s) \geq 1 \text{ and } r_d(s) = r_d(s') = r_d(s'') - 1 \\ \quad \text{if } |g_d(s) - g_d(s')| \leq |g_d(s') - g_d(s'')| \\ r_d(s) \geq 1 \text{ and } r_d(s) + 1 = r_d(s') = r_d(s'') \quad \text{Otherwise} \end{cases}$$

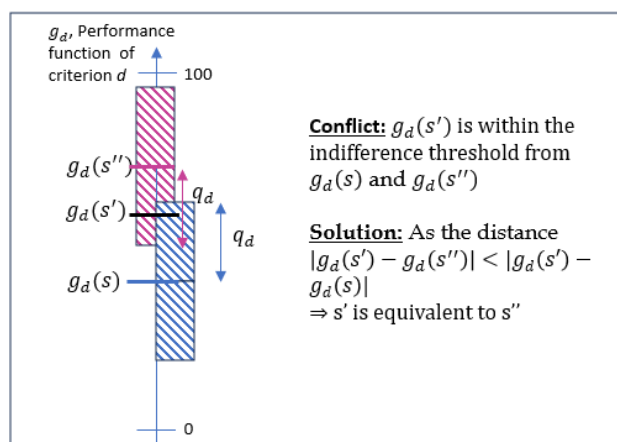

Figure 23: Illustration of a conflict where one solution belongs to the indifference area with two inequivalent solutions.

These two inputs are likely to consider several solutions as equivalent. Section 6.1.2.2 presents a possible approach to deal with these equivalently ranked solutions.

To provide a friendly and interactive User Interface (UI) for the experts to enter their inputs, all solutions are represented in a graph, in which each axe represents a criterion of the AHP tree. The solutions performances for each indicator are only indicated with two small bars indicating the minimum and maximum values and a bold bigger bar indicating the median of performances existing for this criterion. In this first step, the user shall not be able to identify each solution. This is a deliberated choice to avoid biasing the user judgment by already choosing a favorite solution. It is nevertheless a useful information for the users to know on which range the solutions spread. They can assess accordingly if some performances would be acceptable. The user can select on the graph the value or interval of acceptable performances and just need to adapt the indifference threshold if necessary (already populated with default values). The UI is illustrated on Figure 24.

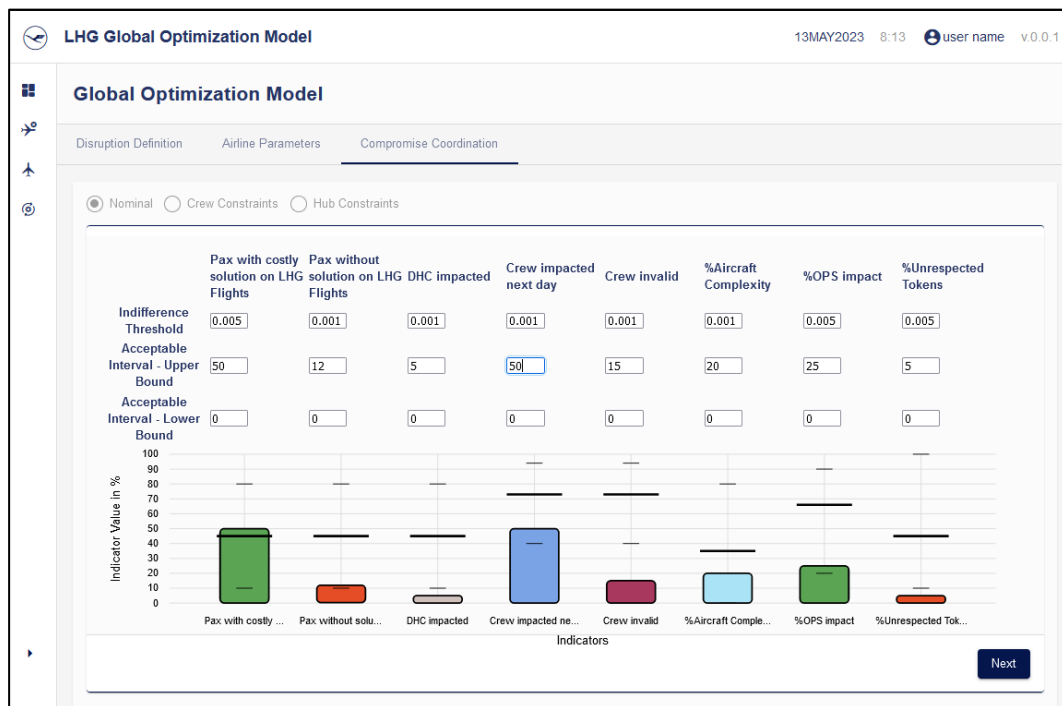

Figure 24: User interface providing the users needed inputs.

All these inputs are useful to model efficiently the decisions-maker operational expert sensitivity, as the data available in the solver will never be enough to represent fully the operational situation with all its subtleties and nuances.

The system is supporting each airline's representative to rank the solutions with their local view. Thanks to the users' inputs (indifference threshold and acceptable performances

interval), the solutions performances for each given criterion are ranked automatically. According to its ranks for each criterion (criterion = voter here), a solution gets a given number of points based on the Borda count method. The solution with the maximum number of points gets the first rank for the local ranking, etc. If two solutions have the same amount of Borda points, placing both on rank  $m$ , we consider them as equivalent and the rank  $m + 1$  is then left empty. This can be further generalized: if  $n$  solutions are allocated the same number of points and thus ranked equivalent by the user, then the  $m + 1$  to  $m + n - 1$  ranks are empty. The rank computed for each user is displayed in the UI and the user can accept the proposed ranking of solutions or change it if necessary. The process of providing the inputs and getting the rank should not take more than 2 minutes (requirement 6.1).

### ***6.2.5. Consensus Identification Method for the Group of Stakeholders***

Once all representatives have adapted or/and validated their proposed rankings by the system, another Borda round is launched, this time considering each airline as a voter, and counting the Borda points attributed by the local rankings previously done. With this method, a solution is identified as a good compromise according to all decision-makers inputs and can be implemented.

### ***6.2.6. Illustration on an Example and Discussion***

#### **6.2.6.1. Local Ranking**

For a given airline  $A$ , participating to a group optimization, let us suppose that the optimizer proposes eight different solutions for the group of airlines. Each performance of each criterion is presented to the airline  $A$  representative, who provides for each criterion an indifference threshold and the acceptable performances interval (see Table 10). We do not consider the global performance as this is calculated based on the group AHP weights and not considering the user subjectivity.

In Table 11, each solution is assigned a given number of points according to the amount of time they are chosen to a specific rank by criterion, and how many solutions are ranked equivalent by the same criterion. For instance, S4 is ranked first by:

- the criterion on operational impact (equivalent with S1, S2 and S3, therefore earning 5.5 points),
- the criterion “invalid crew” (equivalent with S1, S2, S3, S6 and S7, thus earning 4.5 points),

- the criteria on dead head crew impacted, on crew impacted on the next operational days and on passengers with costly solutions (equivalent with all other solutions, thus earning three time 3.5 points),
- the criterion on passengers without satisfying solutions (equivalent with all other solutions, except S6, and thus earning 4 points).

S4 gets then 24.5 points from being ranked first by four criteria, with the influence of the equivalent ranked solutions. Once the points attributed by all criteria, the system sorts the sum of attributed weights from the largest to the smallest, which proposes the ranking for airline A (See Table 12). Its representative can then check the ranking and adapt it if necessary. All other users are proceeding similarly to generate and adapt their local rankings.

Table 10: Table of solutions for airline A on which the Borda will apply.

Solution ID	% Canceled flights	% Operational Impact	% Unrespected Tokens	% Invalid Crew	% crew impacted next day	% Dead Head Crew impacted	% Passengers with costly solution	% Passengers without solution
S1	10%	30%	17%	25%	0%	0%	0%	1%
S2	17%	19%	30%	40%	0%	2%	13%	2%
S3	33%	30%	20%	14%	0%	0%	12%	5%
S4	50%	20%	10%	38%	3%	1%	1%	2%
S5	43%	90%	45%	71%	0%	0%	0%	0%
S6	21%	90%	20%	36%	2%	0%	4%	18%
S7	17%	40%	20%	14%	0%	0%	5%	3%
S8	0%	90%	40%	66%	0%	0%	0%	0%
Acceptable Performance Upper Bound	40%	30%	40%	40%	10%	20%	60%	10%
Acceptable Performance Lower Bound	0%	20%	30%	0%	0%	0%	0%	0%
Indifference Threshold	1%	5%	2%	5%	1%	5%	5%	5%

Table 11: Total Borda points attributed to each solution.

Ranks	S1	S2	S3	S4	S5	S6	S7	S8
Rank1	29	35.5	29	24.5	14.5	19.5	23.5	25.5
Rank2	0	0	0	0	0	0	0	0
Rank3	0	0	0	0	5	0	0	0
Rank4	0	0	3	0	0	3	3	0
Rank5	0	0	0	0	0	0	3	0
Rank6	0	0	0	0	1	1	0	1
Rank7	1	0	0	0	1	0	0	1
Rank8	0	0	0	0	0	0	0	0
SUM	30	35.5	32	24.5	21.5	23.5	29.5	27.5

Table 12: Ranking for airline A based on Borda points.

Ranking for Airline A	Solution ID	Borda Points
1	S2	35.5
2	S3	32
3	S7	29.5
4	S1	29
5	S8	27.5
6	S4	24.5
7	S6	23.5
8	S5	21.5

### 6.2.6.2. Group Compromise identification

The goal of this section is to highlight the behavior and possible outputs of the Borda method for a group consensus. We first illustrate on a simple and clear use-case the Borda

## Chapter 6 - Multi-Stakeholder Consensus Approach

calculations before deep diving into the specific cases. In our simple use-case, we suppose that three airlines A, B and C are participating to the group compromise identification. The respective rankings are presented in Table 13.

Table 13 : Rankings for the three participating airlines.

Rank	Ranking for Airline A	Ranking for Airline B	Ranking for Airline C
1	S2	S2	S1
2	S3	S1_S3_S7	S2
3	S1	-	S7
4	S7	-	S3
5	S8	S8	S5
6	S4	S4	S8
7	S5	S5	S4
8	S6	S6	S6

Table 14: Ranking of the group vision - all airlines' votes.

Global Ranking	Solution ID	Borda Points
1	S2	20
2	S1	17
3	S3	15
4	S7	14
5	S8	8
6	S4_S5	5
7	-	-
8	S6	0

As for the first round of Borda points allocation in section 6.2.6.1, the solutions ranked first are getting 7 points, the solutions ranked second are getting 6 points, etc. Thus, we get the following group ranking in Table 14. Solution S1 gathers 5 points, as ranked third by airline A, 7 points as ranked first by airline C and 5 points as ranked second by airline B but equivalent to S3 and S7 (average of the points allocated to the three first ranks). Therefore, Solution 1 gets 17 points while solution 2 gets the maximum of Borda points (20 points) in comparison with the other solutions.

Let us now assume that the three participating airlines have very different rankings, as shown in Table 15.

Table 15: Illustration of very different rankings.

Rank	Ranking for Airline A	Ranking for Airline B	Ranking for Airline C
1	S1	S6	S8
2	S4	S7	S5
3	S6	S2	S3
4	S3	S3	S2
5	S2	S4	S7
6	S8	S1	S1
7	S5	S8	S4
8	S7	S5	S6

Table 16: Ranking of the group vision - all airlines' votes.

Global Ranking	Solution ID	Borda Points
1	S3	13
2	S2_S6	12
3	-	12
4	S1	11
5	S4_S8	10
6	-	10
7	S7	9
8	S5	7

By following the Borda method and attribution of the points, the Table 16 provides the group ranking, eliciting S3 as the group consensus. One can observe that S3 is no favorite solution ranked first or second by any airline. It is a rather averaged ranked solution at the positions 3 and 4. None of the top ranked solutions by the participating airlines is gathering as many points as S3 because of low ranks given by the other airlines (See S1, S6 and S8). Even if S6 is well ranked by A and B, the fact that C ranked it at the worse position disqualifies it from the best-scored solutions. This outlines the Borda count method behavior aiming at finding a consensus



rather than following the majority of voters' rankings. This is important in our proposed method, as the goal is to reach the best compromise for the whole group. Let us use another example, in which the chosen solution is ranked at the worse position by an airline:

Table 17: Illustration of a very imbalanced situation.

4	Ranking for Airline A	Ranking for Airline B	Ranking for Airline C
1	S1	S6	S8
2	S3	S7	S1
3	S5	S2	S7
4	S4	S8	S5
5	S2	S3	S2
6	S6	S4	S3
7	S8	S5	S4
8	S7	S1	S6

Table 18: Ranking of the group vision.

Global Ranking	Solution ID	Borda Points
1	S1	13
2	S8	12
3	S2	11
s4	S3	11
5	S7	11
6	S5	10
7	S6	9
8	S4	7

S1 gathers the maximum of Borda points. This solution is ranked first by A, second by C. but last by B. This is a very imbalanced situation, in which the Borda process is identifying a controversial solution. By having a look to the other solutions, such as S8, which is ranked second in the global ranking, one can remark that S8 is ranked 6<sup>th</sup>, 4<sup>th</sup>, and 1<sup>st</sup> by the participating airlines. Even if this solution would balance the “fairness” of the consensus, S8 is still less preferred by the third airline, as the 4<sup>th</sup> rank has less influence on a group level than the 2<sup>nd</sup> one. Borda can lead to controversial consensus, but the goal of our method is to identify the best compromise. Thus, an inequity mechanism is necessary, to compensate the disfavored airlines during the next run of optimization and thus target a long-term equity.

The proposition is to use further the Borda count method with weights, as it is already done during elections when groups of voters voted the same way. Let us illustrate the principle based on the former votes presented in Table 17. We assume that airline A was advantaged during the last rounds of optimization and therefore get a weight of 0.20, while airline B, being disadvantaged, get a weight of 0.45. To illustrate the three cases, we suppose that airline C was quite equilibrated towards the other airlines and therefore gets a weight of 0.35. The global ranking is then:

Table 19: Ranking of the group vision with weights influence.

Global Ranking	Solution ID	Borda Points
1	S8_S7	4.45
2	-	-
3	S2	3.90
4	S6	3.55
5	S1	3.50
6	S3	3.25
7	S5	2.85
8	S4	2.05

Here the weights slightly disregard that S8 is ranked 6<sup>th</sup> by airline A and give more importance to the ranked 4<sup>th</sup> S8 and ranked last S1 from airline B. This leads to a situation in which two solutions S8 and S7 are equivalent for the first rank in the global ranking. The assignment of weights should be linked to the long-term equity balance (see chapter 7).

In many situations, Borda method can lead to *ex-aequo* solutions being ranked first in the global ranking. Thus, a process must be proposed to ensure that only one solution will be proposed as the best compromise for the group. As few inputs shall be asked to the users, an automatic process must take place. As the primary goal is to reach the best solution for the group, if several solutions are ranked first by the group compromise approach, it is logical to choose the one with the best group evaluation from the AHP (calculated in P3 on Figure 10).

### 6.3. Chapter Conclusion

In this chapter we built on the literature review presented in Chapter 5, extended it to the decision-making under uncertainties and the social vote theory in section 6.1 and proposed a methodology for a group optimization and decision-making to reach a group consensus in section 6.2.

The optimizer, driven by a multi-stakeholders AHP-based evaluation method, provides a set of optimal solutions for the group. As the decision-makers have subjective views that can conflict, coordination is key, and all participating stakeholders must agree on the solution to implement. A full AHP with a pairwise comparison of the alternatives is not possible as the decision process must be feasible in a small number of minutes. The same constraints of limited users' inputs and computation time leads to disregard the outranking methods such as PROMETHEE and ELECTRE for a group compromise process. Methods for the decision under uncertainties such as the Choquet and Sugeno integrals require many inputs users and are not straightforward to understand for any decision-maker not used to these notions. Therefore, we oriented our research on the social vote theory and selected the Borda count method as a clear, easily understandable, and adaptable methodology for a group compromise process.

A first process corresponding to P4 on Figure 20 enables the user to get a dedicated ranking based on a few inputs: for each criterion, the user provides values (that are pre-filled with default values, defined with the experts beforehand, such as only changes are necessary) for the indifference threshold and the acceptable interval of performances. We differ here from a standard Borda count method as the user expert sensitivity is modelled thanks to pseudo-

criteria (through indifference threshold and acceptable interval of performances) and integrated in the proposed ranking, which can be adapted by the user before getting in the global ranking. A standard application of the Borda method would not allow to consider this human sensitivity and knowledge. In this first Borda application, one criterion is considered as one voter.

To enable a faster process, we propose default values in the UI so that the user just need to adapt the ones he needs. Based on this information, a Borda round takes place considering each criterion as a voter. The proposed ranking is returned to the user for validation (or adaptations if the user is not satisfied). This is a key element in airlines operations and ATM as the complexity cannot be fully caught by data, and that the human has a broader situation awareness and operations knowledge.

Once all airlines validated their rankings, a second Borda round is applied considering each airline as a voter. This provides the final ranking for the group and the solution ranked first is implemented (task P5 on Figure 20). Inequity Weights per airline, linked with the current equity index of the history, are used as a compensation mechanism to influence the group decision, and thus help reestablishing equity.

One could argue that such a process is still time-consuming and that in the event of challenging operations, the users of each airline might not have the time nor the willingness to input all these information and go through this consensus process. Therefore, an alternative solution is proposed to enable some or all airlines to “skip” the manual consensus process and get automatic ranking and group solution identification without any required input. For that, the first Borda round is replaced by a local assessment of the airline’s performances thanks to local AHP weights. These AHP weights comes from different questionnaires than the group one. Each airline is required to fill in each season not only the group AHP Questionnaire, but also three other AHP questionnaires related to different operational scenarios, these ones with the own airline’s strategy and benefits (see section 7.2.2). This local assessment through the local AHP weights provides a local ranking of the group solutions for the airline without any required users inputs. It feeds the second Borda round for the elicitation of the group consensus solution to implement.

## 7. Long-Term Equity Approach

As outlined in the previous chapters, a group optimization is conceivable only if a measurement of the equity linked with a compensation mechanism is proposed. As stated in section 3.1.4, granting a strict equity at each optimization instance would restrict the search space and reduce the chances for finding a truly good solution for the group in terms of passengers rebooking, crew and operational impact. Within the Air Traffic Management (ATM), numerous approaches tried to offer a better use of the constrained capacity through more flexibility. However, most of these promising concepts were hindered due to the limitation to a strict equity in each situation ((Vossen *et al.*, 2003), (Pilon *et al.*, 2021)). To enable efficient group decision and optimal group solutions, the stakeholders must accept to temporarily be disadvantaged. Nevertheless, if the acceptance of a group consensus at the expense of some stakeholders can be accepted, it must be guaranteed and proven that this is beneficial for all stakeholders on the long-term, e.g., that all stakeholders are gaining on the long-term from temporary inequity within the group.

A group equity index in our context must fulfill the following requirements. First, the equity index must be able to perceive the airline's sensitivity according to the specific local operations challenges. As the equity index that we aim for must be calculated on the long-term, it must be calculable on a history of instances.

**Requirement 7.1:** The equity index shall be calculable on multiple instances and shall consider the airline's sensitivity relative to each situation (operational sensitivity and human loss aversion).

The objective of a long-term equity index is to assess how much each airline is positively or negatively impacted by the group decisions, in comparison with the other ones.

**Requirement 7.2:** The equity index shall enable an easy decomposition per airline to enable a straight quantification of each airline "inequity share" into the global equity balance.

Finally, the primary goal of a long-term equity index is to:

**Requirement 7.3:** The equity index shall provide a trustable measure of equity on the history and shall detect the compensations over time that happened, to rebalance the equity of the group optimizations.

Therefore, this chapter proceeds first to a review of the equity index from the literature (section 7.1). This sub-section and consequent analysis were published in 2021 at the ATM seminar (Carré *et al.*, 2021b). Section 7.2 proposes then to build a truly unique method, measuring on the long-term the equity and proposing a compensation mechanism for the small imbalanced situations.

### 7.1. Literature Review on the Equity

Equity triggered numerous philosophical and political discussions, as well as scientific research to contribute quantifying as objectively as possible the equity of a situation. Nowadays, this notion is still a source of debates and research. By equity, we refer to a “fair” and “just” distribution of benefits among the actors. Many definitions and concepts, though, can meet this definition (Lewis *et al.*, 2021). It is thus crucial to clarify the understanding of equity in a group decision-making context and then prove thanks to a transparent equity assessment to all actors that the decision reaching global performances is equitable.

The problem of equity, especially in justice or politics, had been identified since and analyzed for over more than a century. (Price and Rowntree, 1902) published a first article outlining the inequity in poverty and (Knapp, 1902) tackled the first social effects of transportation, especially the spatial distribution on railways. Later, economics and public transportation network design problems based their equity definition on the justice approach and developed it further. Quantification of the inequity of access to the public transports is substantial in the field of transport accessibility ((Bouf and Desmaris, 2015; Cavallaro *et al.*, 2020; Dixit and Sivakumar, 2020; Hananel and Berechman, 2016; Niehaus *et al.*, 2016; Sharma, 2020; Sun and Zacharias, 2020; Wang *et al.*, 2020; Zhao and Cao, 2020), etc.), economic and sociologic sciences such as the gender wage inequity (Fourrey, 2019), or the equity of education resource allocation (Omoeva *et al.*, 2019) and energy research such as the energy access equity (Chapman *et al.*, 2018), and equity in shared sea resources (Zagonari, 2018). An article presenting an extensive literature review on equity approaches applied to transportation field has been recently published (Lewis *et al.*, 2021).

### 7.1.1. *Equity Approaches*

Philosophically, one could separate in categories the different approaches about equity. (Zagonari, 2018) identified three trends, based on the philosophical approaches mainly developed in the XVIII century, to which we added a new one developed by (Martens, 2016):

- The utilitarian approach aims to maximize the total benefits considering all actors as one and prefers a total benefit higher with a poor fairness, than a slightly slower benefit with a high fairness. Translated into our use-case, this means that solutions with very good group performances, but poor fairness would be positively considered.
- The egalitarian approach aims to equalize benefits for all actors, disregarding the intrinsic differences, and capabilities of each actor. This approach would negatively consider solutions with high performances for the group but with poor fairness. This highlights the difference between equity and equality. Equality aims for the strict same number of benefits while equity relates to improve the benefits considering the initial repartition among the stakeholders (e.g., an improvement of x% of the initial situation). This is rather unaligned with the long-term equity definition proposed in our context, as we aim for equity and not strict equality (otherwise, equality would be an optimization indicator or even a constraint).
- The contractarian approach aims to improve the benefits of each actor, still respecting the initial differences, and according to specific contracts or agreements between the actors (maximizing the benefits of the actors having the worse results). This could be an interesting approach for our operational use-case.
- The so-called “sufficientarian” approach aims to ensure a sufficient level of benefits for each actor according to its needs. It uses a threshold notion, which negatively influences the equity index if an actor does not reach this threshold. It have been used by (Martens, 2016) to enhance the already proposed vision of equity. This notion of threshold could be very interesting in our case, to differentiate the solutions acceptable with equity imbalance, from the too imbalanced and inequitable solutions.

Research community proposed several indexes through the years, mainly focusing on economical calculations such as income equity index. We will present three of the main ones, recognized by the scientific community and applied in multiple fields and analyses.

### 7.1.2. Rules for Equity Measurements Indexes

Equity indexes are based on years of research, especially in economics. They must follow a given number of rules, reminded by (Fourrey, 2019). The main ones are:

- Normalization (for perfect equitable distribution, the index is zero, otherwise it is positive),
- Symmetry (who gets the highest or smallest income does not matter, this is an anonymity principle),
- Dalton-population principle (invariance of the index if the population is replicated),
- Pigou-Dalton transfer rule (if a transfer from one “rich” individual to a “poor” individual happens, the equity index must decrease),
- Continuity of the index (if a small variation in the income share happens, a small variation in the index should be observed),
- Relative invariance (if all incomes are multiplied by a constant, the index should not change the index).

### 7.1.3. Gini Index

Historically, one of the first indicators tackling inequity is the Gini index (Gini, 1912). The Gini index expresses the distribution of different incomes between the different actors. With a comparison for each pair of individual  $i$  and  $i'$ , with  $N$  the number of individuals, and  $x_i$  the income of the individual  $i$ . The Gini index is calculated as following in Eq. 95:

$$GI = \frac{\sum_i \sum_{i'} |x_i - x_{i'}|}{2 \times N^2 \times \text{average}(x_i)} \quad \text{Eq. 95}$$

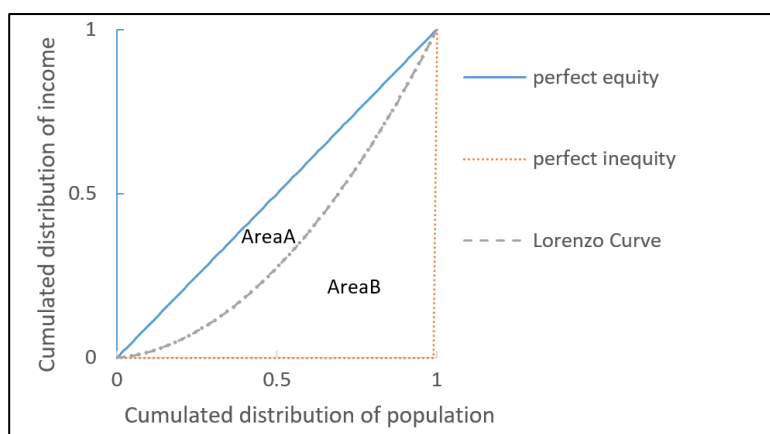

Figure 25: Illustration of the Lorenz curve

The Gini index calculates the quotient of the area between Lorenz curve and the strict equality curve and the area under the strict equality curve (Figure 25). The Lorenz curve is the cumulated distribution of income corresponding to the cumulated distribution of individuals groups. The strict equality curve is a straight line from point (0,0) to point (1,1) (also called “perfect equality line” as all incomes are equally distributed). Gini index is then equal to 0. The “perfect inequality line” corresponds to the entire incomes share belonging to one group of individuals. As the individuals are ranked by incomes, the Perfect Inequality line corresponds to the red line plotted in Figure 25. Gini index is then equal to 1. Gini index has the advantages to be easily computable, recognized by the scientific community as one of the fundamental equity indexes and intuitively understandable.

However, the absolute value captures difference between two airlines but does not reflect if the difference is in favor or at the detriment of the airline. Gini index reflects the inequitable situation with a strict equality approach. No loss aversion is considered, which is in contradiction with requirement 7.1.

#### 7.1.4. Theil Index

Theil proposed another index (Theil, 1967), more sensitive to the groups’ sizes of individuals and their income shares. He based his index on the principle of entropy in information theory. The principle is: the smaller the probability is that an event would occur, the higher the interest. The logarithm function of  $(1/x)$  is modelling this requested behavior (Sen and Foster, 1997, p. 35). For each  $i \in \{1, \dots, N\}$ , an event that could happen, we write  $w_i$  the event probability. The expected information resulting of the situation is “the sum of the information content of each event weighted by the respective probabilities”, defining the entropy  $Q(w)$ :



$$Q(w) = \sum_i w_i \cdot \ln\left(\frac{1}{w_i}\right) \quad \text{Eq. 96}$$

Theil introduced two changes in Eq. 96 to analyze the income concentration. First, the probability  $w_i$  is replaced by the income of one individual  $s_i = x_i/N \cdot \mu$ , with  $\mu$  being the average on  $i$  of  $x_i$  (historically the mean income). Secondly, he defined the index as the difference of the maximal entropy ( $\ln(N)$ ) and the current entropy  $Q(s)$ . Theil index can be written as in Eq. 97 and with the expression of  $s_i$ , can be expressed as in Eq. 98 .

$$TH = \ln(N) - Q(s) = \sum_i s_i \cdot \ln(N) - \sum_i s_i \cdot \ln(s_i) \quad \text{Eq. 97}$$

$$TH = \frac{1}{N} \cdot \sum_i \frac{x_i}{\mu} \cdot \ln\left(\frac{x_i}{\mu}\right) \quad \text{Eq. 98}$$

The use of ln function in Theil index tends to focus on the negatively impacted cases:

- If  $x_i > \mu$ ,  $x_i/\mu > 1$  and  $\ln(x_i/\mu)$  is increasing slowly towards  $+\infty$ ,
- If  $x_i = \mu$ ,  $x_i/\mu = 1$  and  $\ln(x_i/\mu) = 0$ . No influence on the equity index as the airline  $i$  reached the mean value of performance,
- If  $x_i < \mu$ ,  $0 \leq x_i/\mu < 1$  and  $\ln(x_i/\mu)$  is rapidly decreasing towards a vertical asymptote.

For the same deviation (noted  $e$ ) above or under the mean value of performances, the disfavored airline has larger impact on Theil index as  $\left| \ln\left(\frac{\mu-e}{\mu}\right) \right| > \left| \ln\left(\frac{\mu+e}{\mu}\right) \right|$ .

Theil index has interesting properties. Firstly, it is differentiating the airlines being favored from the one disfavored, thanks to the positivity or negativity of the ln function. Secondly, its sensitivity to a disfavored airline, affecting more the total index, reflects the sentiment of injustice experienced by this airline. Human tendency is to pay more attention to his loss than to his gain (Kahneman and Tversky, 1979). This is called loss aversion. Inequity is also about decision-makers feelings, not only mathematical calculations based on just tangible reality.

These abilities also enable a clear understanding of each airline contribution to the inequitable situation. The index can be decomposed without losing any quality in the global index, except for the special case of where the airline's contribution is 0 triggering a doubt between  $x_i = 0$

or  $x_i = \mu$ . This is particularly interesting in our use-case, as we could observe adequately the position of each airline in the global inequity of each solution.

### 7.1.5. Atkinson Index

Atkinson modelled his index differently, aiming at an equity in welfare rather than income. He expressed it as the incomes required to enable total welfare being exactly equal to the welfare generated by the actual income distribution. He formulated as  $y_e$  being the “equally distributed equivalent level of income” (Atkinson, 1970). With  $\mu$  being the average income, the best equality is reached for  $y_e = \mu$ . As for Theil and Gini index, the perfect equality reached is reflected by the index being equal to zero. Therefore, Atkinson Index (AT) is  $AT = 1 - y_e/\mu$ . Atkinson used the generalized mean with exponent  $p$ , also called Hölder mean, to calculate  $y_e$  in function of the real distribution of the  $y_i$ . We then can traduce with  $n_i$  the number of individuals in the income category  $y_i$  as in Eq. 99:

$$\frac{y_e}{\mu} = \left( \sum_i \frac{n_i}{N} \cdot \left( \frac{y_i}{\mu} \right)^p \right)^{\frac{1}{p}} \quad \text{Eq. 99}$$

As the function is strictly concave, the inequity aversion is modeled as the utility elasticity, which is evaluating the relative change of the utility in relation with the individual income changes. For simplification purposes, Atkinson assumed that this inequity aversion is constant, which defined the utility function as in Eq. 100:

$$U_e(y) = \begin{cases} \frac{y^{1-\varepsilon}}{1-\varepsilon} & \text{if } \varepsilon \neq 1 \\ \ln(y) & \text{if } \varepsilon = 1 \end{cases} \quad \text{Eq. 100}$$

Using  $p = 1 - \varepsilon$ , with  $\varepsilon$  representing the aversion to inequality, which characterize the Atkinson index ( $\varepsilon = 0$ : no aversion to inequity;  $\varepsilon = 1$ : each individual has the same weight;  $\varepsilon$  tends towards infinite: the indicator tends to consider only the worse observation). This gives Eq. 101:

$$AT_\varepsilon(y) = \begin{cases} 1 - \left( \sum_i \frac{n_i}{N} \cdot \left( \frac{y_i}{\mu} \right)^{1-\varepsilon} \right)^{\frac{1}{1-\varepsilon}} & \text{if } \varepsilon \neq 1 \\ 1 - \left( \prod_i \frac{x_i}{\mu} \right)^{\frac{1}{N}} & \text{if } \varepsilon = 1 \end{cases} \quad \text{Eq. 101}$$

The greater  $\varepsilon$  is, the more the transfers of income in the lower end of distribution are influencing the index (De Maio, 2007). This index is interesting to know which end of the distribution is the most unequal and contributed the most to the inequality measure.

Atkinson index has the advantage of considering the parameter  $\varepsilon$  influencing the index results with inequity aversion. This is very interesting to enable more flexibility to the decision-makers by defining the aversion level of inequity depending on the disruption extent. However, while Atkinson index fulfill requirements 7.1 (calculable on a history) and 7.3 (trustable quantification of the inequity levels), requirement 7.2 related to the decomposability of the index is not easily satisfied. The contribution of each airline to the inequity level cannot be easily retrieved. Thus, the Atkinson Index is not a candidate for an adaptation towards the multi-airline operations optimization problem.

#### *7.1.6. Critical Analysis of the Literature Equity Indexes*

Each index behavior was analyzed on several solutions, designed to highlight each unique index behavior:

- Balanced repartition in terms of cancelled flights per airline (same percentage),
- Extremely imbalanced solution, in which one airline cancels all its flights, corresponding to the required number of cancellations for the group,
- Extremely imbalanced solution, in which one airline cancels the 10 required flights, which correspond to 70% of its originally planned flights,
- Solutions representing strict equality, in which all airlines cancel 2 flights,
- Imbalanced solution, where only half of the airlines cancel for the entire group,
- Imbalanced solution, where all airlines except one are cancelling fully booked flights.

The detailed sensitivity analysis on these solutions for the three Gini, Theil and Atkinson indexes can be found in the (Carré *et al.*, 2021b).

The analysis highlights well the strict equality behavior of the Gini index. As three airlines are cancelling for the entire group, the differences with the two other airlines are adding up, regardless of whether this is in favor or not to the considered airline. This leads to the Gini index to consider that a solution with half of the airline cancelling for the group is more unfair

than a solution in which only one airline undertakes all cancellations for the group. The absolute value captures difference between two airlines but does not reflect if the difference is in favor or at the detriment of the airline. This is a major obstacle to the Gini index utilization in our context, as only the differences are considered and added up, leading to a strict equality view.

In Theil index, using the  $\ln$  function needs one adaptation: if  $x_i = 0$ , Theil's convention stipulates that  $\ln(0) = 0$ . This convention is interesting: as Theil index is the sum of all inequity contribution, an airline, completely disfavored, is not balancing the total index, and only the positive contribution in favor of the other airlines is added up. Therefore, the global index will be higher, expressing a higher inequity measure, than with a negative contribution from the completely disfavored airline. This is well observable between the two solutions in which one airline cancels all required flights for the group, either corresponding to all its planned flight or corresponding to 70% of its planned flights. The only drawback of this convention is the decomposition of the index in airline's inequity contribution. Indeed, if the contribution is 0, it must be verified if it is due to a complete unequal situation ( $x_i = 0$ ) or an exact mean performance position ( $x_i = \mu$ ). Thus, a new convention should be proposed to express the inequality of the situation towards the completely disfavored airline.

### 7.1.7. Conclusion

Economical science main equity indexes are Gini, Theil, and Atkinson indexes. Depending on the equity definition of the problem (such as a strict equality or an equity considering the human sensitivity of loss versus gain), one of these equity indicators might suit better the purpose. These indexes are not used only for poverty measurements but also to support transportation science projects and decision such as new public transport lines or higher frequencies to plan.

In the flight operations, fairness calculations are tackled mainly on the crew recovery part, but only for the initial plan. Once in operations, fairness is not considered anymore, the focus is robustness and stability of the plan (EASA rules). As from our knowledge, no true fairness nor equity definitions were proposed in ATM research up to now, and only some early propositions exist in the context of exploratory research projects of SESAR ((Mocholi, 2022; Pilon *et al.*, 2016; Schuetz, Ruiz, *et al.*, 2022)). However, the equity measures are simple, based on the hypothesis that everything can be translated into financial gain or loss, and do not really consider the specific user situation, sensitivity, nor the human trend to feel more losses than gains.

The critical analysis of the different indexes (see section 7.1.6) showed that Gini index measures equity as a strict equality, while Theil and Atkinson indexes gives more importance to disadvantaged airline, modeling thus the human sensitivity to loss in contrast with gains. Atkinson index allows even more flexibility by expressing the inequity aversion in the formula itself and influencing thus the index results. However, it is not decomposable per participant, in contrast with Theil index. The decomposability of an index enables to easily assess the participation of each stakeholder to the situation's inequity. Therefore, the Theil index seems quite interesting for further development and adaptation to the multi-airlines' operations decision-making.

## **7.2. Application of a Long-Term Global Equity Index**

This section aims at proposing a first approach for a long-term equity index, with the definition calculations for the group, the development of a compensation mechanism and an illustration on the effectiveness of the method based on some examples.

As pointed out in section 7.1.7, Theil index is well suited for calculating the inequity of a situation thanks to its modeling of the human loss aversion, and its decomposability. Theil index is however able to quantify the inequity only on one given situation, not on several instances. A consistent aggregated view of the instances' history must first be developed.

### ***7.2.1. Modelling the Airlines' Sensitivities***

Each airline perceives its operational performances differently according to the operational situations and its daily priorities. These priorities change depending on the resources available, the daily events and constraints, etc. As the inputs required from the user must be limited, there is no possibility to ask each airline user to provide its daily priorities and indicators' weights at each instance. Thus, a similar process than the one presented in chapter 5 can be used, this time to capture each airline local vision and linked weights. The operational situations were grouped in three main scenarios:

- A nominal situation: the operations run normally, no special bottleneck is foreseen,
- A crew constraints situation: no or limited crew duty buffer between the planned duty end time and the duty limit from EASA/Airline's rules, and no or limited crew reserve. This means that the focus should be put – for example – more on limiting delays on the

airline flights, so that the crew duty time limits are emphasized in the local performances' calculations,

- A hub constraints situation: the airport hub from which the airline is operating is having capacity restrictions – for example due to snow fall, or event taking place at the airport – and the airline would be keen on more cancellations from their flights for the group if their connecting passengers are taken over by the other airlines.

We propose to each airline to fill in the AHP questionnaire at the beginning of each new operational season not only for a group vision, but also three other ones for their local airline vision for each scenario listed above.

Each airline user simply indicates at the beginning of the new optimization instance in which operational scenario its airline is. According to the solution chosen by the group at the end of the consensus phase, the local performances per airline are calculated, based on, for each airline independently, its local AHP weights corresponding to the operational scenario selected. These local performances per airline are recorded in a database as the airline local performance of the solution implemented. This provides the history of airlines local performances for each instance.

### *7.2.2. Calculation for the Long-Term Global Equity Index*

For each new instance, once the group solution has been identified through the compromise process (see chapter 6), the global equity index is calculated as follow. First, the local performance for the chosen solution is calculated for each airline. The history of the local performance is available for calculating the current “equity share” or each airline in the global equity index.

The easiest way to aggregate consistently the history of local performances per airline is to average it. Indeed, depending on the disruptions, some airlines might not participate to the group optimization if they do not have flights impacted. Using the sum to aggregate the history would result in wrong basis for the Theil index calculation. In Theil index, the interpretation of the mathematical elements is as follow:

- $i \in \{1, \dots, N\}$ : an airline with  $N$  the number of airlines,
- $x_i$ : performance of the airline  $i$  for the analyzed equity elements,
- $\mu$ : average of all airlines' performances on the analyzed equity element,

It is worth mentioning that  $x_i$  must follow the same pattern than the income:  $x_i > \mu$  corresponds to an airline  $i$  with better performances than the average (solution at airline  $i$ 's favor). As we are in a minimization problem, and that the Theil index is developed for a maximization problem (initially for the income equity), the average performance must be subtracted to 1 ( $x_i = 1 - \text{avg}(perf_{i,t})$  with  $perf_{i,t}$  being the performance of airline  $i$  at iteration  $t$ ). This gives the basis for the Theil index to be calculated.

$$TH_{global} = \frac{1}{N} \times \sum_{i \in Airline} \frac{x_i}{\mu} \times \ln \left( \frac{x_i}{\mu} \right) \quad \text{Eq. 102}$$

$$\forall i \in Airline, temp_i = \frac{x_i}{\mu} \times \ln \left( \frac{x_i}{\mu} \right) \quad \text{Eq. 103}$$

The simple average of the historical local performances has the drawback that a very inequitable instance will not be captured as very unfair if it happens after numerous instances. Figure 26 shows on the upper graph the local performances of chosen group solution for each airline (the higher the bar, the worse the performances for the airline). The scenario of 74 instances is based on a slightly unfair solutions distribution, in which the airline LX always had a local performance bigger than 0.1 (randomly assigned local performances between 0.1 to 1) while the two other airlines are randomly assigned local performances from 0 to 1. We induced two perturbations on iterations 39 and 49, in which LX (respectively SN in iteration 49) is very much impacted by the group solution while the other two airlines are having very good local performances. The aim is to see the evolution of the global inequity as defined above and analyze its sensitivity (lower graph) to the slightly unfair optimizations and the perturbations induced in the system. The red line represents the equity threshold under which the curve should be to claim having an equitable system. This threshold was identified through extensive analysis (see Appendix C) with different scenarios of several cases where one or several airlines are a bit, or a lot disadvantaged in comparison to the others on multiple instances. This enabled to identify the equity threshold that should be reached to ensure a sufficient level of equity. This threshold is  $TH = 0.001$ .

## Chapter 7 - Long-Term Equity Approach

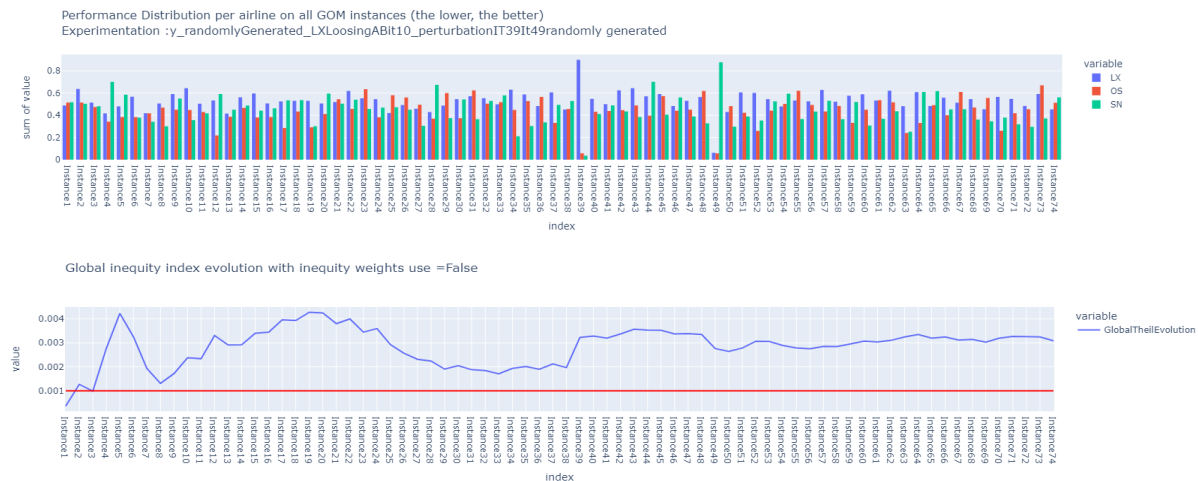

Figure 26: Global equity index evolution (lower graph) on a slightly unfair scenario.

One can remark that the global equity index is always above this equity threshold as the optimization always disfavored one specific airline. One can also observe that the increase of global inequity perceived by the index in iteration 39 is lower than the one perceived at iteration 2. The historical previous local performance through the average gives more inertia to the global equity index sensitivity. However, for the airline LX, which is tremendously suffering from iteration 39, the inequity is felt far more than what is represented by the current global equity index.

Therefore, we developed two other approaches intending to provide a more accurate sensitivity of the global equity index for recent inequitable situations than first instances in the history. A rolling horizon and a linear decrease of the impact of the historical instances were tried out.

A rolling horizon has the advantage that the global equity index is always calculated for an agreed number of instances. However, if one instance, causing a very high equity index (such as iteration 39) which was not compensated by the later instances – supposed quite equitable for all airlines – is disappearing from the rolling horizon, the global equity index will suddenly measure only the subsequent quite equitable instances and report a better equity within the group (see iteration 59 lower graph in Figure 27). Moreover, if some airlines are participating only from time to time (due to different market and airport flown than most of the other airlines), the inequity level for them can be complicated to properly calculate. It thus necessitates a time horizon large enough to capture their last participations.

A linearly decreasing importance of the instances with the time is another approach: instead of “forgetting” an unfair situation from the past, this will still influence the global equity index. However, a new unfair situation on a relatively stable equity index (such as the induced



perturbation at iteration 39) will have a higher influence on the global equity index. What we observed on Figure 27 is that the behavior of the simple average and the linear decrease of past instances are having a quite similar behavior after 12 iterations, simply not on the same scale. One drawback of this approach is also for airlines participating sporadically to the group optimization due to their business model: the last instance in which they might have been disadvantaged is for the airline’s users still predominant, while the linear decreasing model would tackle it as less important than the more recent instances. Therefore, a linear decrease of importance of the past instances might not be a proper modeling.

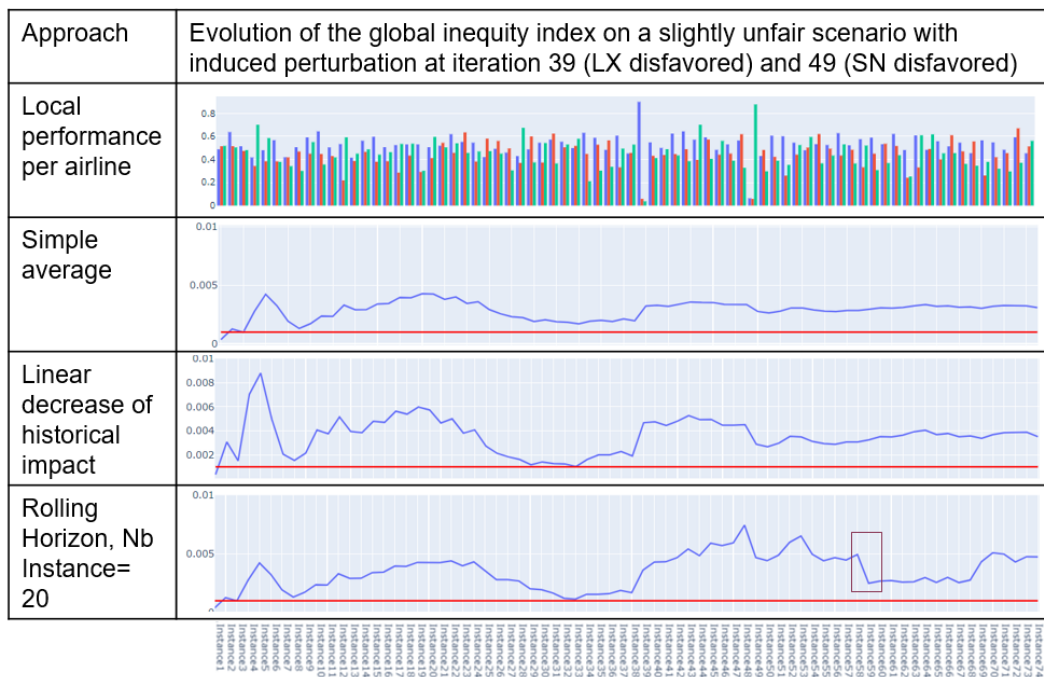

Figure 27: Different approaches for calculating the long-term equity index.

Based on the previous observations and on the knowledge that users from different airlines might be very sensitive to inequity, the paragraphs above present three different modeling of the injustice feeling from the airlines’ users, considering the history, and the memory effect. These three modeling can be considered as an additional parameter of the system depending on the users’ reluctance to inequity and their way of thinking.

However, the most promising modelling is the average on a rolling horizon big enough to enable airline with low participation to be still well considered. In agreement with SWISS (funding this thesis), it was decided to use the rolling horizon approach with a time horizon corresponding to the expected average number of instances within one season: 40 instances. The reasoning is that no airlines should participate less than a couple of times per season. One

of the advantages is also that no “resetting” must be proceeded between two seasons and thus reduces the efforts needed to use the system.

Thus, the average of each airline local vision is performed for the last 40 instances, and the Theil index calculates the long-term global equity index.

### 7.2.3. Compensation Mechanisms

#### 7.2.3.1. Concept Developed

Only calculating and reporting the global inequity status is not enough. In case of slightly imbalanced system, some airlines might be systematically more disadvantaged than others. Therefore, a compensation mechanism must be designed to enable an internal compensation mechanism influencing the global inequity without biasing the group optimum calculations. This corresponds to the task P6, detailed in Figure 20, p. 96. As the group consensus rely on the Borda count method (see section 6.2.5), the idea is to influence with inequity weights the Borda points distributed from each airline’s ranking (see Figure 28).

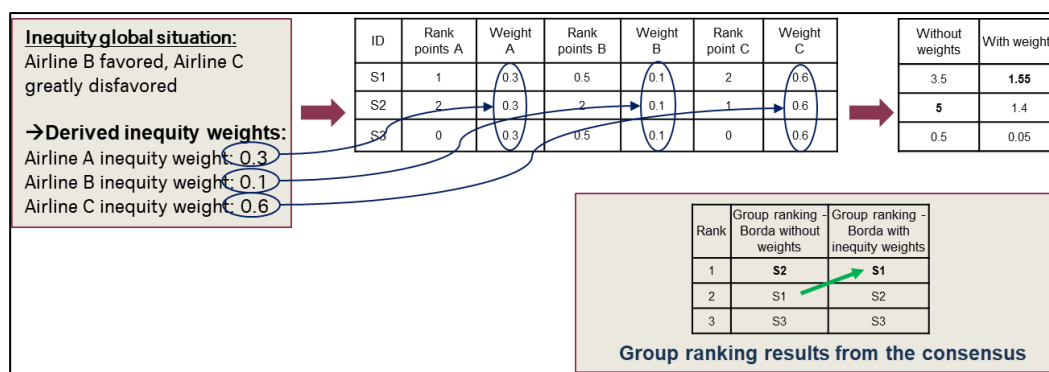

Figure 28: Illustration of the inequity weights influence on the group consensus.

A compensation mechanism must be able, based on the global inequity evaluation, to provide more weight to an airline, which is disfavored. Thus, during the next rounds, and as long as the equity balance is not reached, this airline should have a greater influence on the group ranking, and potentially choose a solution which brings locally better performance than the other solutions.

A hypothesis must be here expressed: this compensation mechanisms and the possibility to compensate the inequity within the system and the consensus identification works only if the group optimization is not intrinsically imbalanced. Indeed, if the optimization settings – or simply the group business optimum vision – is very different to one airline’s business, this airline might always be impacted more than the others. If the imbalance is too important, an internal compensation mechanism will not be sufficient to offset the inequity. Such imbalanced

situations must thus be tackled externally to the system. This is also the reason for which the inequity calculations and “inequity share” per airline must be transparent to all users. If the inequity of the system cannot be reduced through the compensation mechanism, all airlines must be aware of that and a managerial decision must be taken, either to recalibrate the system, to redesign the group vision or to exempt the specific airline.

From the inequity share of each airline, easily calculable thanks to the decomposability of the Theil index (see Eq. 103, p. 122), inequity weights must be traduced to provide some more weights to the airlines during the group consensus process. A sensitivity analysis was conducted (see Appendix C) on different types of ranking situations to validate the concept.

Now that the concept of inequity weights influencing the group Borda ranking are explained, the mathematical definition of the inequity weight calculation based on the global equity index is proposed in the following paragraphs.

#### 7.2.3.1. Mathematical Definition of Inequity Weights

Different approaches were presented to calculate the inequity weights, all based on the airlines’ participations to the global inequity that we note  $temp_i$  as in Eq. 103 (p. 122). These methods are described in Appendix C. The particularity is that the  $temp_i$  are real values (positive or negative numbers) and must be derived into inequity weights – noted  $inequityW_i$  –, which means that:  $\forall i \in Airline$ ,

- $inequityW_i \in [0,1]$ ,
- $\sum_{i \in Airline} inequityW_i = 1$ ,
- The smaller  $temp_i$ , the higher  $inequityW_i$ .

Different approaches for calculating these inequity weights were proposed. The first attempt to propose a linear approach was mathematically impossible. A second method consists in measuring the distance of the average local performances with the best performances possible (as the  $temp_i \in [0,1]$  is maximized, the distance to 1 is calculated for each airline). A third approach is based on TOPSIS method to calculate the similarities coefficient for each airline to the ideal and anti-ideal solutions (defined for each airline by applying the local AHP weights on the best performance reached by any airline for the given indicator among the proposed solutions). The inequity weights are then the average of the similarity’s coefficients on all previous instances. The fourth and last method developed is based on a famous selection

method in the reinforcement learning field called SoftMax (Cardarilli *et al.*, 2021). After an in-depth analysis of the four methods, on different scenarios of imbalances, the three first methods showed some limitations in their sensitivities to inequity, as well as their ability to reestablish a global equity. However, the SoftMax function – also called Boltzmann SoftMax operator – showed very interesting results in the group ranking by accenting the disfavored airlines and thus reestablishing efficiently the long-term global equity. This method was thus selected.

In the machine learning field, more specifically in reinforcement learning such as neural networks, the probability of a neuron to be activated is defined by a function standardizing a set of numbers (being positive or negative) into a set of probabilities that sum up to 1 (Asadi and Littman, 2017). This SoftMax function is also called Boltzmann SoftMax operator as it comes from the Boltzmann distribution expressed with a coefficient  $\beta > 0$ , and initially explaining thermodynamic behavior (Eq. 104). The Boltzmann distribution is also used in statistical mechanics (Engelhardt *et al.*, 2015).

$$P_i = \frac{e^{-\beta \times \varepsilon_i}}{\sum_i (e^{-\beta \times \varepsilon_i})} \quad \text{Eq. 104}$$

The exponential modeling comes from the parallel between energies and probabilities, where energies sum up while probabilities multiply.  $\beta = 1/\tau$  is a positive parameter, with  $\tau$  called the *temperature*. The higher the temperature is, the bigger is the probability for a high-energy state to exist. When considering different states with different energy levels, the probability to have one state with a very high energy is very low, as the probability of an equilibrated system with one state with very high energy and the other ones with very low energy is rather small. This is the behavior searched for in our long-term inequity system. The more an airline gathered “energy” (which means in our context favorable local performances through the history), the less inequity weight it should have in the group decision. This high-energy state is reachable only at the costs of the other airlines (having thus “low energy” states). Through the exponential function, the airlines with low “energy” have a higher probability and therefore weight in the next group decision.

Another aspect is worth mentioning. The lower the temperature parameter is, the bigger are the gap between the probabilities of different states is. Therefore, the system with a low temperature would emphasize more discrepancies between different levels of energy. The parameter  $\tau$  was subject to a parametrization on several scenarios including unbalanced

situation to identify the right value to use in our problem (for more details see Appendix C). Figure 29 illustrates this last behavior from the Boltzmann SoftMax operator.

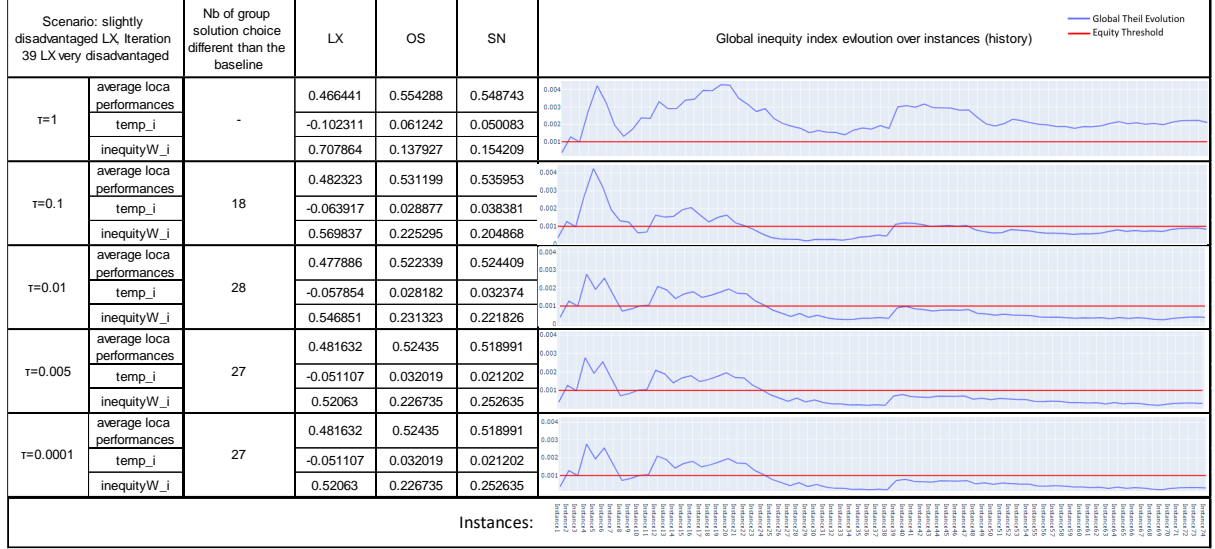

Figure 29: Influence of the  $\tau$  parameter from the Boltzmann SoftMax function on the global equity index influenced by the inequity weights (on 74 instances).

Figure 29 shows that the influence of the parameter  $\tau$  on the global equity index is very high from  $\tau=1$  to  $\tau=0.1$ , then still influence the global inequity towards better influence of the disfavored airlines for  $\tau=0.01$  and  $\tau=0.005$ . However, the difference between  $\tau=0.005$  and  $\tau=0.0001$  is marginal. It also highlights the number of changes in the group solutions compared with the baseline (i.e., without inequity weights influence). Indeed, with  $\tau=0.1$ , 18 solutions out of 74 are differently chosen from the group perspective, while for  $\tau=0.005$ , 28 solutions are different. This choice of different solutions is driven by the inequity weights, and thus helping reestablishing the global equity.

To close the parallel, the Boltzmann SoftMax indicator is set up as following for calculating the inequity weights for each airline based on the historical instances and equity imbalances, with  $\tau=0.04$  (see Appendix C for the detailed calibration):

$$\forall i \in \text{Airline}, \text{Inequity}W_i = \frac{e^{-\frac{\text{temp}_i}{\tau}}}{\sum_i \left( e^{-\frac{\text{temp}_i}{\tau}} \right)} \quad \text{Eq. 105}$$

#### 7.2.4. Illustration on an Example

Still on the scenario where LX is slightly disadvantaged (randomly having performances within  $[0.1,1]$  instead of  $[0;1]$  as the others), the baseline is the long-term inequity and the group solution choices with no inequity weights (see Figure 30). With the parameter  $\tau=0.04$ , the

number of instances for which the group solution differs from the one chosen in the baseline is counted. One third of the instances (24 over 72) are presenting a different group solution consensus, that are more in favor to the disfavored airlines on the history. This explains that the blue curve representing the long-term inequity is evolving below the equity threshold. The inequity weights efficiently support the airline disfavored (in this case LX) by increasing its weight in the group consensus process. One can remark that on iteration 39, where LX is very disadvantages, the weight for LX is suddenly increasing, and so is the global inequity. However, in iteration 49 where SN is very disadvantaged, the inequity weight from SN is increasing while the one from LX is decreasing.

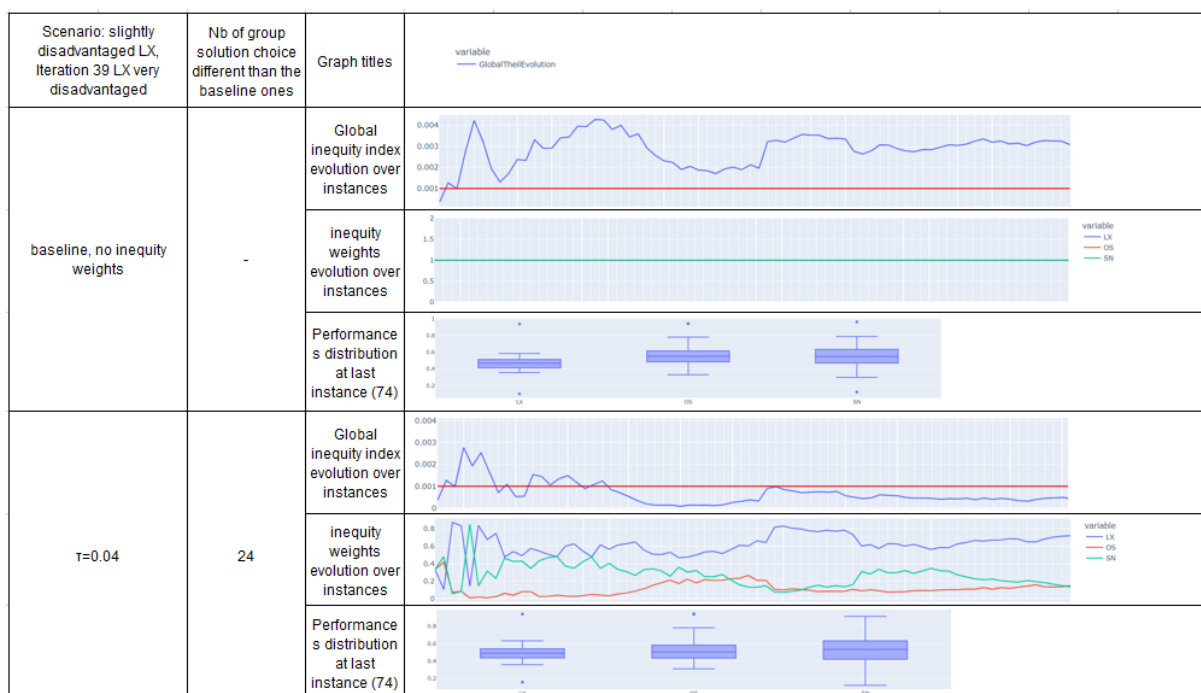

Figure 30: Long-term equity outcomes comparison with and without inequity weights.

By allowing the inequity weights to provide increased importance to the disfavored airlines in the group consensus, the Theil based inequity weights normalized through the Boltzmann SoftMax function presents a successful and efficient compensation mechanism on a slightly imbalanced system.

### 7.3. Conclusion

A group optimization can disfavor some airlines more than other. Guaranteeing a strict equity of the group solution among the airlines would require considering the equity within the solution assessment. This would bias the search for a group optimum, and the true optimality could not be granted anymore. Therefore, temporary inequity is accepted by the users, but this must be tracked and if necessary compensated.

This chapter proposed a definition and an application of a long-term global equity index. A literature review highlighted three equity indexes developed in the context of quantifying the inequity in income distribution: Gini, Theil and Atkinson indexes. Gini index expresses strict equality instead of equity, which is not the concept aimed for a multi-airline operations optimization. Atkinson index is modelling not only the loss aversion but considers the inequity aversion. However, it is difficult to decompose into each airline “participation” and thus identify the inequity share. Theil index models the loss aversion (part of requirement 7.1), enables an easy decomposition per airline in inequity share (requirement 7.2) and is a trustable measure of equity in the literature. Therefore, the Theil index is adapted to fulfill all requirements identified for a long-term global equity index.

Modelling each airline sensitivity (part of requirement 7.1) assumes that each airlines gives different importance to the indicators defined through the AHP in chapter 5. Thus, we first calculate the airlines’ own local performance according to their defined weights. This is done through three additional AHP questionnaires per airline, getting the weights for three main operational scenarios: nominal, crew constrained or hub constrained operations. The local weighted performances of each airline per instance is thus calculated.

Three methods were proposed to enable an aggregated view of all local performance history per airline. A simple average on all instances, a linear decrease of the instance influence on the aggregated local performance per airline, and a rolling horizon averaging the local aggregated performance. The rolling horizon method is chosen, with a time horizon corresponding to the expected number of opportunities for group optimization. This is an intuitive way to calculate a multi-instance situation per airline without further settings needed. If an airline is slightly disfavored, the average will reflect it. With the right Theil index threshold, identified through multiple experimentations, the Theil index can spot inequity and represent it in its value. Moreover, as an illustration of the situation is always easier to assess in complementarity of the Theil index value, a boxplot graph can be proposed to the users, as presented in the Appendix C.

This long-term equity index, considering all previous instances of the time horizon, is the basis to define inequity weights. To transform the decomposable “participation” of each airline to the Theil equity index into an inequity weight, we use the Boltzmann SoftMax operation (initially developed from the Boltzmann distributions) with a parameter  $\tau$ . The smallest this parameter is, the more it gives weight to disfavored airlines in the group consensus process.

## Chapter 7 - Long-Term Equity Approach

After analyzing on multiple instances scenarios, the parameter chosen was  $\tau = 0.04$ . This is a strategical decision that could be adapted to each business and each airlines group according to their goals and strategies.

These inequity weights are then influencing the group consensus for the next optimization instance. Each Borda points defined by the airline ranking in the group consensus are multiplied with the inequity weights. The disfavored airlines have more weight in the group decision and thus get an optimal group solution affecting less its operations (or even slightly favoring it). Analysis on multi-instances scenarios were conducted to confirm and illustrate the inequity weights efficiency as a compensation mechanism.

In summary, we proposed an approach to calculate the equity on a history of instances. Each instance is presented with the local performance of each airline, calculated with their own sensitivity, as each indicator might have a different weight for each airline locally, depending on its operational situation. The long-term equity index is based on the Theil index, initially developed for poverty inequity assessment. By using an average on a rolling horizon on the instances' history, this enables to translate the inequity of the history into the necessary input for calculating the Theil index. As from the long-term Theil index value, the decomposable "inequity share" from each airline can be retrieved and translated into inequity weights thanks to the Boltzmann SoftMax indicator. These inequity weights efficiently influence the second Borda round proposed in chapter 6 to strengthen the airlines disfavored by the group optimizations in the history in the group consensus process.

One disclaimer must be noted: this compensation mechanism is achieving its full potential only in situations that are quite balanced between the airlines. We cannot guarantee that it will always converge to global equity on the long-term, as it depends on the situations, the calibration, and the real group optimal. If one airline is having a business strategy very different of the group's one, and therefore is locally considering the proposed solutions as impacting very much its business (e.g., group vision on the passengers with high value such as first and business class passengers are not relevant for a low-cost oriented airline such as Eurowings), the compensation mechanism won't be enough to equilibrate again the long-term situation towards a more equitable one, as the optimizer will always search for solutions evaluated best from the group vision. In such a case, either the group vision must be reviewed, the airline



participation to a group optimization might be questionable, or an external compensation mechanism to the optimization system must be defined.

# Proposition of a Group Optimization Method

---

The previous part introduced the multi-criteria methods enabling the core optimizer to evaluate different solutions and decide which ones are the optimal ones with a group vision. This part aims at proposing a method for optimizing the schedule and the passenger problem, assessing the solutions quality thanks to the AHP approach defined in chapter 5.

The constraints in the response time of the optimizer are strict (2 to 5 minutes). A first thought could be to use the same optimization method to solve the scheduling and the passenger problems in an integrated way. However, this would bring an ultra-high dimensionality problem, where the best optimization method would not be efficient. This is why we split the schedule and passenger recovery problems with two separated methods to solve each problem. The passenger recovery problem is imbricated in the schedule recovery problem. This part first provides a literature review about the metaheuristics methods commonly proposed for NP-complete scheduling problems, and then describe the methodology adopted for the group optimization of the flight scheduling and the passenger flows.

## **8. Optimization of the Flight Schedule**

As discussed in chapter 2, numerous optimization methods exist to approach the optimal solution of the scheduling problem (aircraft recovery problem). As this problem is NP-complete, no exact method can provide solutions in a reasonable time. This chapter presents the main methods to address NP-complete problems (section 8.1). Based on this knowledge, a presentation of the methodology adapted to our problem will be highlighted with some examples for a better understanding (section 8.1.2).

## 8.1. Literature Review on Scheduling Optimization Methods

### 8.1.1. Literature Review on Metaheuristics

Metaheuristics are generic methods, adaptable to numerous optimization problems. Most of the metaheuristics reproduce random and iterative processes, observed by – for example – physical phenomena or animals’ behaviors, to explore efficiently the search space and find optimal or near-optimal solution. Depending on the considered problem, some methods could be more relevant than other ones, and the calibration part to the specific optimization is one of the keys for a successful application. In particular, the trade-off between the exploration phase (browsing through the search space) and the exploitation part (as from the existing solutions, try to converge towards the most promising one) can be quite challenging and crucial for the method efficiency. A metaheuristics method will never guarantee to find the optimal solution but enable to find a suitable solution in a quite efficient time rather. The metaheuristics methods can be categorized as following (see Figure 31): individual-based methods and population-based methods.

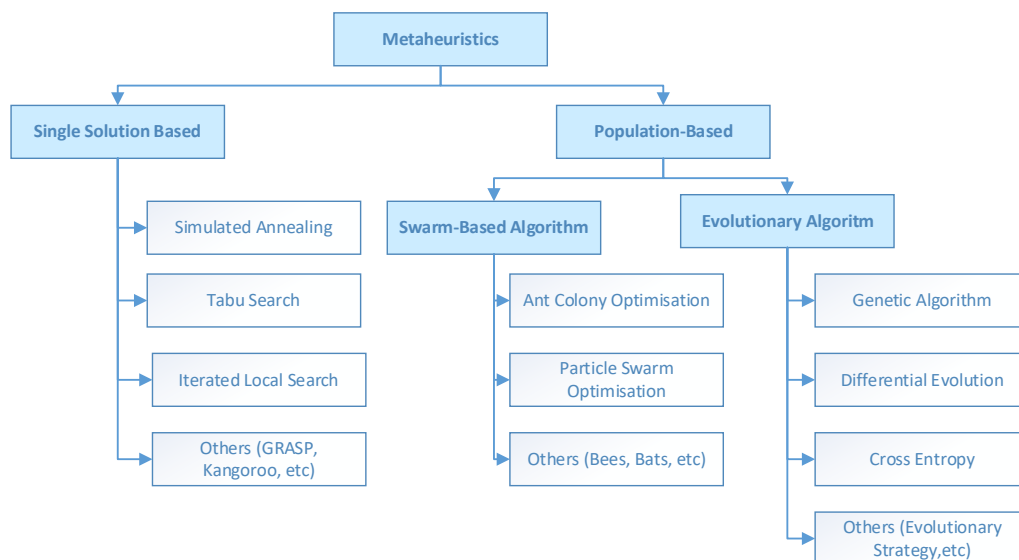

Figure 31: Metaheuristics methods illustration, based on (Ezugwu et al., 2021).

#### 8.1.1.1. Individual-based metaheuristics methods

Individual-based methods rely on searching in the neighborhood of an existing solution, by moving around following predefined processes. The three main methods are the simulated annealing, the Tabu search and the iterated local search.

The Simulated Annealing (Kirkpatrick *et al.*, 1983) reproduces the behavior of a metallurgical process called annealing, ensuring a good metal quality. The optimization method uses this annealing analogy to first “melt” the system to optimize, allowing random walk through the

possibilities thanks to high temperatures, before slowly lowering the temperature by small steps until the system “freezes”. The reader can find the algorithm’s steps in (Deroussi, 2016, p. 45). This method is easy to implement, provides good solutions for problems on discrete as well as on continuous variables and avoid the local optima.

The Tabu Search (Glover, 1989) consists in continuing searching for a solution even if local optima are reached by allowing movements, which are not improving the solution. To this end, the algorithm uses a list of forbidden movement called “tabu list”, to keep the set of solutions tried recently and thus avoid turning back on a solution already assessed. The reader can find the algorithm’s steps in (Deroussi, 2016, p. 50).

Iterated Local Search consists in proceeding iteratively to a local search to find a better solution than the current one (Lourenço *et al.*, 2003). As from an existing solution, it first searches in the neighborhood for a better solution. It then uses a perturbation phase to enable the new solution to move out of the current local optimum, and then proceed for a local search around the new solution. As a third step, it decides to keep the new or to come back to the previous solution. The reader can find the algorithm’s steps in (Deroussi, 2016, p. 48).

The multi-airline operations optimization requires exploring efficiently the search space that can be quite large. Individual-based methods are not adequate to achieve this requirement in a limited computing time. Therefore, the literature review of metaheuristics will follow on population-based methods. Population-based methods rely on several individuals exploring the search space, thus covering more space within an iteration, and communicating each other some information. Based on their partial knowledge, the individuals are influenced in their movements and should converge towards the optimal (or near-optimal) solution.

### **8.1.1.2. Evolutionary algorithms**

Based on Darwin’s statement that a population evolves thanks to natural selection, the evolutionary methods (Baeck *et al.*, 1997) propose the following analogy: the solutions, inheriting of characteristic well adapted to their environment, tend to live long enough to reproduce while weaker solutions tend to disappear. Thus, each population is subject to changes during a succession of iterations, called generations. During each generation, operations based on genetic mechanisms are preparing the next population’s generation. Each operation uses one or two individuals called parents to generate new individuals called children. At the end of each generation, a set of selected children replaces a sub-set of individuals from the population. The algorithm is then iterating through evaluation, selection, reproduction, and replacement

phases. The Cross-Entropy method (Rubinstein, 1997) is based on Monte Carlo method and is applicable both for combinatorial and continuous problems, with either static or noisy objectives. It has been developed to estimate rare events probabilities in complex static contexts. The most famous method of evolutionary algorithm, though, is the genetic algorithm.

Genetic Algorithms are based on genetic mechanism to create new individuals (Goldberg and Holland, 1989). It selects some parents to generate children, which should both ensure that the best individuals are reproduced, and that some diversity in the population is kept increasing the chances of finding better solutions. Famous methods are the fitness-proportionate selection, tournament selection, elitism from the previous population. Each individual corresponds to a chromosome (a solution) composed of genes (variables to optimize) which allele is the value of the gene. Different standard mutation technics exist, such as the crossover or the mutation. The reader can find the algorithm's steps in (Deroussi, 2016, p. 51). As shown in chapter 2, several researchers used the GA for airline operations problem with good results. The GA could be a good option for a schedule optimization in our multi-airline operations optimization (see (Liu *et al.*, 2008) in section 2.1).

#### 8.1.1.3. Ant Colony Optimization (ACO)

The Ant Colony Optimization algorithm is inspired by the ant behavior. One individual is unable to optimize complex problems, while a population of individuals communicating together can. The ants use pheromones to communicate. If an obstacle is on their way between their home and the food, the ants try to find the shortest path, which is also the one coming back the fastest. Thus, the pheromones quantity by time unity is higher on the shortest path. Moreover, an ant is even more attracted to a given place, if the pheromones rate is high. Therefore, the shortest path will have a bigger probability to be used by ants and will be at the end used by all ants.

This algorithm was developed by (Colorni *et al.*, 1991) to propose a method solving the famous "travelling salesman problem". An evaporation rate of pheromone trails is necessary to avoid searching solution only in local optima. The better the solution is, the more pheromone are dropped by the ant on the solution. The ACO requires that the optimization problem to solve is described by a graph. By initializing the first node of the graph, from which all ants are departing, the probability to go towards the next city depends on a probability based on the "costs/distance", the desirability (pheromone rate) of the considered arc, which is compared to the sum of all other arcs, to get a probability. Each ant is building block by block its solution,

marking each of its decision by releasing some pheromone on the arc chosen. The solutions are compared at the end of the iteration (local updating rule). The pheromone path found with the best performance since the beginning of the algorithm is reinforced. The reader can find the algorithm's steps in (Deroussi, 2016, p. 53).

The Ant Colony Optimization method is also well designed to solve other optimization problems (continuous or discrete) (Dorigo and Blum, 2005) as it enables strong parallelization, robustness (research can be efficient even if some individuals are defective) and the decentralization (no central authority commanding the ants). It was also successfully applied to scheduling problems such as task scheduling (Yi *et al.*, 2020) and was already proposed for the aircraft recovery problem modelled as graphs (see section 2.1). However, it can tend to be trapped in a local optimum and have difficulties to jump out (Yan *et al.*, 2023).

### 8.1.1.4. Particle Swarm Optimization (PSO)

The particle swarm optimization is a population-based algorithm using a population (called a swarm) of candidates' solutions (called particles) to find optimal solutions to the problem. Based on observation of animals evolving in swarm – like fishes and birds –, (Kennedy and Eberhart, 1995) proposed this algorithm. The core principle is that one individual has a limited intelligence and knows only his position in the swarm and local environment, while the entire group can evolve with very complex and dynamic patterns. In contrast to the Ant Colony Optimization, the PSO can optimize many problems, be it modelled as a graph or not.

Each particle of the swarm is a solution evolving in the search space. It knows its current position and the related performance of it, the position of the best performance it reached in his history, as well as the best positions and performances of its defined neighborhood particles. A neighborhood is composed by different particles exchanging information together about the best position that they found. Based on this information and on the current behavior (randomly influenced) of the particle, the particle updates its position and assesses the performance of it. The particle's behavior is defined by the inertia coefficient (trend to follow its way), cognitive coefficient (trend to go towards its historical best position) and social coefficient (trend to go towards the position, on the history of its neighbored particles that reached the best performance since the beginning of the process). Different types of neighborhood topologies either static or dynamic as well as randomized. The reader can find the algorithm's steps in (Deroussi, 2016, p. 54).

Although this method has been originally developed for continuous optimization problems, (Kennedy and Eberhart, 1997) proposed a discrete binary version. (Clerc, 2004) set the path for numerous adaptations to combinatorial optimization problems with successful applications. It was applied on general scheduling problem (see section 8.1.2.2) but was never proposed for the aircraft recovery problem (as from the author's current knowledge).

#### **8.1.1.5. Conclusion**

The different metaheuristics described above provide a general understanding of the methods and their philosophy. As expressed in the introduction of this chapter, the metaheuristics methods can be applied to any complex optimization problem and solve it efficiently if the definition of the variables, the proper mechanisms and the right strategies are identified. A careful calibration must be performed to bring the metaheuristic to its full potential.

The first outcome is that a population-based algorithm is necessary for our approach. Indeed, the research space being vast, one individual cannot guarantee to find an optimal solution and might have an important probability to be trapped in a local optimum. The population-based algorithms offer better exploration of the search space in an efficient way.

Secondly, the Particle Swarm Optimization (PSO) has the advantage to be quite easily understandable by neophytes (one of the main requirements for the users' trust in a new operational system is to be intuitively comprehensive and avoid the "black box" effect), easy to implement and converge efficiently with the right settings. In comparison with the Genetic Algorithm (GA), the PSO has two main advantages. Firstly, it enables lower efforts in parameters setting (requirement from the operational tool that an admin user without real optimization knowledge could calibrate the system every season or major business change). Secondly, it necessitates lower computation efforts, due to the quick update required from the PSO equations versus the crossover and mutation techniques, children per children, which are quite computing time intensive in the GA.

(Toader, 2014) showed that the PSO is a well-adapted method for the production scheduling problem and was able to always find faster solution than the Ant Colony Optimization (ACO) as well find better solutions in 80% of the cases. (Surekha and Sumathi, 2011) also demonstrated on the Fuzzy Job Shop Scheduling Problem that the PSO outperformed the ACO. However, other articles claim the contrary and no real common understanding seems to be currently agreed (Karunya and Deepa, 2022). As the majority tends to consider the PSO outperforming ACO for scheduling problems, PSO seems adequate in our context.

Additionally, it is worth mentioning that in the literature study presented in chapter 2, none of the scientific articles reviewed were proposing a recovery approach based on the PSO. While ACO was applied mainly for the aircraft and crew recovery problem ((Deng and Lin, 2011), (Sousa *et al.*, 2015), (Zegordi and Jafari, 2010)), it could be interesting to propose a first application of the PSO method to solve the aircraft recovery problem, especially knowing that PSO is already famous for scheduling problems such as job shop, flow shop and tasks scheduling problem (Gad, 2022).

As our optimization must converge in a quite restricted time to a good (if not optimal) solution, our optimization method for the flight-rescheduling problem will be based on the PSO. Therefore, the following part will concentrate on the Particle Swarm Optimization (PSO), its adaptations for discrete problems and our own application of the PSO on the multi-airline operations optimization problem.

### 8.1.2. Particle Swarm Optimization Method

#### 8.1.2.1. Continuous PSO

As briefly explained in section 8.1.1.4, each particle  $i$ , in a swarm of  $N$  particles, represents a position  $x_i$  (=a solution), which evolves in a  $D$ -dimensions search space, a dimension being noted  $j$ . Each particle communicates with other ones, called neighbors. The PSO associates local search methods (thanks to own experience) and global search methods (thanks to the neighbors' experience). Each particle's position is evaluated through a fitness function. For each particle  $i$ , at each iteration  $t$ , we know (see illustration on Figure 32):

- Its current position at iteration  $t$ , the solution-vector:  $x_i^t = (x_{i,1}^t, x_{i,2}^t, \dots, x_{i,D}^t)$ ,
- Its velocity at iteration  $t$ :  $v_i^t = (v_{i,1}^t, v_{i,2}^t, \dots, v_{i,D}^t)$ ,
- The position at which it reached its best performance (called cognitive memory) at iteration  $t$ :  $pbest_i^t = (pbest_{i,1}^t, pbest_{i,2}^t, \dots, pbest_{i,D}^t)$ ,
- The position at which a particle of its neighborhood (or itself) reached the best performance known (called social memory) at iteration  $t$ :  $gbest_i^t = (gbest_{i,1}^t, gbest_{i,2}^t, \dots, gbest_{i,D}^t)$ .

During the update phase, the particle's position is updated according to its velocity. This is influenced by three parameters:



- The inertial component: the particle tends to follow its current trajectory,  $w \times v_{i,j}^t$ ,
- Cognitive component: the particle tends to move towards the best location that it already reached,  $c_1 \times \left( r_{1,i,j}^t \times (pbest_{i,j}^t - x_{i,j}^t) \right)$ ,
- Social component: the particle tends to trust its neighbors experience and moves towards the best location already reached by them,  $c_2 \times \left( r_{2,i,j}^t \times (gbest_{i,j}^t - x_{i,j}^t) \right)$ .

With:

$v_{i,j}^t$  Velocity of the particle  $i$  on dimension  $j$  at the iteration  $t$ .

$x_{i,j}^t$  Position of the particle  $i$  on dimension  $j$  at the iteration  $t$ .

$w$  Inertial coefficient.

$c_1$  and  $c_2$  Acceleration coefficients.

$r_{1,i,j}^t$  and  $r_{2,i,j}^t$  Random value between [0,1] at each iteration  $t$  and for each dimension  $j$  and each particle  $i$ .

The influence of these three components (inertial, cognitive and social ones) is done thanks to trust coefficients, to encourage the exploration or exploitation of the solution space. These coefficients are influenced randomly with the acceleration coefficients  $r_{1,i,j}^t$  and  $r_{2,i,j}^t$ . The particles follow the velocity to update their position at each new iteration (Eq. 106, p. 140, illustrated on Figure 32).

$$\forall i \in \{1, \dots, N\}, \forall j \in \{1, \dots, D\}, \forall t \in T,$$

$$\begin{cases} v_{i,j}^{t+1} = w \times v_{i,j}^t + c_1 \times r_{1,i,j}^t \times (pbest_{i,j}^t - x_{i,j}^t) + c_2 \times r_{2,i,j}^t \times (gbest_{i,j}^t - x_{i,j}^t) \\ x_{i,j}^{t+1} = x_{i,j}^t + v_{i,j}^{t+1} \end{cases} \quad \text{Eq. 106}$$

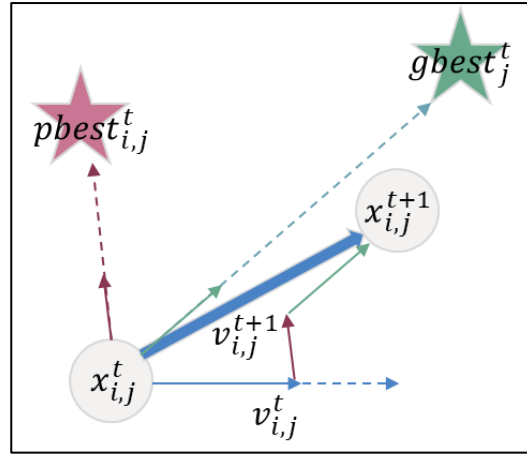

Figure 32: Particle Swarm Optimization – illustration of the movement of a particle.

Each particle's velocity for each dimension respects  $|v_{i,j}^{t+1}| < V_{max}$ .  $V_{max}$  allows controlling the algorithm's divergence as well as a trade-off between exploration and exploitation (Kennedy and Eberhart, 1997). Once the particle's position is updated thanks to Eq. 106, the new position's performance is evaluated and compared to its previous  $pbest_i^t$  and  $gbest_i^t$ :

Let us define  $f: x_i \rightarrow f(x_i)$  the performance assessment function (see chapter 5) in a minimization objective function and  $Neighb_i$  the set of neighbors' particles of  $x_i$ .

$$\forall i \in \mathbb{N}, \forall j \in \{1, \dots, D\}, \forall t \in T,$$

$$pbest_i^{t+1} = \begin{cases} pbest_i^t & \text{if } f(x_i^{t+1}) \geq f(pbest_i^t) \\ x_i^{t+1} & \text{otherwise} \end{cases} \quad \text{Eq. 107}$$

$$gbest_i^{t+1} = \min_{Neighb_i} f(pbest_i^{t+1}), 1 \leq i \leq N \quad \text{Eq. 108}$$

The historical neighborhood definition, consisting in having all particles communicating with the entire swarm (case a. on Figure 33), was rapidly abandoned as the swarm is converging too fast towards a local optimum ((Kennedy and Eberhart, 1997), (Coello Coello and Reyes-Sierra, 2006), (Izakian *et al.*, 2010), (El Dor *et al.*, 2015)). Different topologies were proposed, some static ("social neighborhood"), other dynamic ("physical neighborhood") and even randomized neighborhoods. Physical neighborhood are more expensive in computation time than social ones, as it requires updates of the new neighborhood at each iteration (Clerc, 2004). Some researchers also proposed to use sub-swarms to cluster the information sharing, grant a better exploration process and allow adaptive neighborhoods (Clerc, 2003), (Cooren *et al.*, 2009).

Typical topologies are illustrated in the Figure 33. It is recommended to start with social neighborhood defined as a ring topology (case b. on Figure 33).

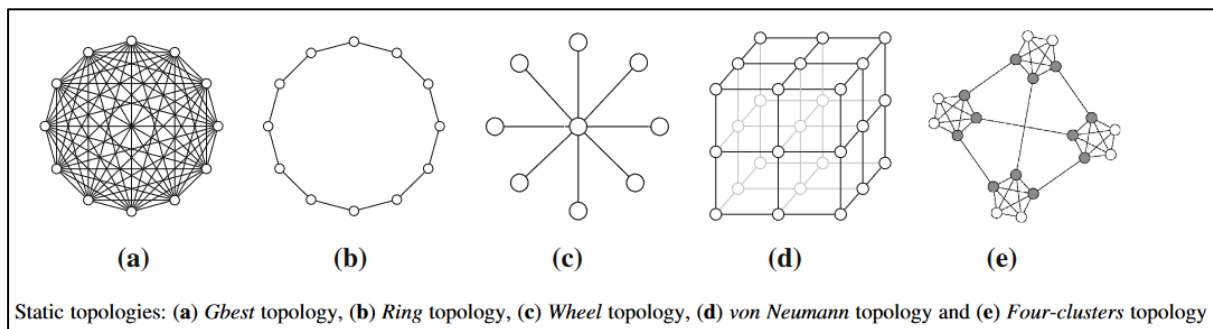

Figure 33: Different neighborhood topologies illustrated by (El Dor et al., 2015).

The process continues (modification of the position and velocity, assessment, and update of  $pbest_i$  and  $gbest_i$ ) until one of the following convergence criteria is reached:

- The fixed iterations number,
- The objective function reached sufficient quality level,
- The velocity variation is almost 0 (i.e., the particles are all stagnating on a local or global optimum).

The pseudo code of the classic PSO is:

```

 $f: x \rightarrow f(x) = \text{objective function}$ 
Initialization:
Initialize randomly the position and velocity of  $N$  particles
Evaluate the performance of each particle position  $f(x_i)$ 
For Each particle  $i = 1, \dots, N$ 
     $pbest_i^{t=0} = x_i$ 
     $gbest_i^{t=0} = x_i$ 
Next  $i$ 
Optimization:
While stopping criteria are not reached
    Update the particles' velocities and positions (Eq. 106)
    Evaluate the particles positions (Chapter 5)
    Update the particles  $pbest_i$  and  $gbest_i$  (Eq. 107 & Eq. 108)
End While

```

Figure 34: general pseudo-code of the Particle Swarm Optimization

As stated before, the PSO has been successfully adapted to combinatorial optimization problem, despite its initial definition for continuous optimization problems. As the scheduling

problem of multi-airline operations optimization is a discrete problem, a quick overview of methods for discrete PSO is proposed before deepening into the method selected.

### 8.1.2.2. Discrete PSO

In the literature, three main approaches emerge for discrete problems:

- A stochastic velocity problem: a position is a vector of binary numbers  $x_i^{t+1} = (x_{i,1}, x_{i,2}, \dots, x_{i,D})$  and a velocity is a vector  $v_i^{t+1} = (v_{i,1}, v_{i,2}, \dots, v_{i,D})$  determining how the position will evolve in the search space.  $v_{i,j}$  is considered as a probability that  $x_{i,j}$  can take the value 1 (Kennedy and Eberhart, 1997). This can be extended also for non-binary positions, by defining a velocity per dimension. The velocity with the highest value is picked as the next particle's position for this dimension,
- A discrete definition of operators adapted to the problem itself: (Clerc, 2004) developed an approach of the discrete PSO for the Traveling Salesman Problem by defining a position as a sequence of  $D + 1$  cities (numbered from 1 to  $D$ ) to visit in a given order, with the first element being equal to the last element (cycle). The velocity is defined as an operator applying permutations to the  $D$  elements of the position vector. The velocity thus is considered as a list of transpositions. The evaluation function is the sum of the costs of the arcs connecting two consecutive elements of the particle. A discrete definition of operators requires extensive effort to develop an adapted framework for the given problem to solve.
- A discrete definition of the space search: the particles evolve in a continuous space. Each continuous position is then transformed into a discrete position by applying a given rule. For example, the rule of the Smallest Position Value (SPV) (Tasgetiren *et al.*, 2004): based on the velocities, the smallest one gives the value of the particle's 1<sup>st</sup> dimension, the second smallest velocity gives the value of the particle's 2<sup>nd</sup> dimension, etc. This works well for sequencing problems. For example, the position [0.28; 0.65; 0.17; 0.53] gives the job ordering [3; 1; 4; 2] as the smallest value (0.17) is the third one in the position vector, etc. Another rule can be to simply round up the value to the nearest integer.

Many sequencing jobs problems propose different variants of the discrete PSO. However, the scheduling problems are quite different in the sense that one dimension can take multiple different values, and that the decision process for one dimension to be updated can trigger

numerous calculations. Therefore, permutations might be less suitable for high dimensional problems. Different approaches for the scheduling problem were designed.

(Shiau, 2011) proposed for university scheduling to add the velocity value to the position value and round up or down the obtained value for the new position. For a particle position  $x_i^t = (1, 13, 57)$  and a new velocity calculated to be  $v_i^{t+1} = (1.758, 1.312, -2.3)$ , the new position is:  $x_i^{t+1} = x_i^t + v_i^{t+1} = (2.758, 14.312, 54.70) = (3, 14, 55)$ . The authors must bound the velocity to bring some stability in the new particles (same mechanism as the  $V_{max}$ ). One drawback is that constraints are not considered in this method. Thus, the authors designed a small algorithm checking if all constraints are respected, and if not, regenerate a velocity until all are respected. Having a velocity update method considering already the constraints would reduce well the computation time.

Some other approaches, such as (Izakian *et al.*, 2010), focused on efficient computation time for grid job scheduling. The particles positions are defined as a  $1 \times d$  vector, with  $d$  being the number of jobs to assign to machines. Each element of the position-vector is a natural number belonging to  $[1, m]$  with  $m$  being the number of machines available.  $x_{i,j}$  value corresponds to the machine to which the job  $j$  is assigned. Different jobs can be assigned to one machine, it will be performed one after the other. The velocity is a matrix  $m \times d$  with elements belonging to  $[-V_{max}, V_{max}]$ . Instead of applying the full PSO equation on all elements of the velocity matrix, and checking for each one if it corresponds either to the job assignment of key position (either last particle position,  $pbest$  or  $gbest$ ), only the elements assigned in one of these three positions are updated accordingly, with specific operations as presented in the pseudo-code (Figure 35). After the velocity update matrix, the new particle dimension is assigned to the machine having the highest velocity.

The benefit of (Izakian *et al.*, 2010) approach is to reduce the number of operations during the velocity update, as only the velocities corresponding to machines assigned per dimension to the key positions are subject to updates for cognitive and social memory (see section 8.1.2.1). In problems with particles having numerous dimensions, this allows to reduce the computation time as well as an intuitive and understandable approach. Another benefit is the well-structured update of the velocity and positions. In the contrary of (Shiau, 2011) where the particles definitions are quite loose, this method ensures that the new position is already bounded to realistic positions and does not necessitate extensive repairing process.

```

Update at iteration  $t$  of the particles' positions:
For Each  $particle\ i = 1, \dots, N$ :
  For Each  $job\ j = 1, \dots, d$ :
    //  $q, z, s \in [1, m]$  ;
    //  $v_{i,j}^t(q)$  the velocity of particle  $i$ , for job  $j$ , and for machine  $q$ , at iteration  $t$ .
       $q = x_{i,j}^t$ ;
       $z = pbest_{i,j}^t$ ;
       $s = gbest_{i,j}^t$ ;
      If  $q \neq z$  then:
         $v_{i,j}^{t+1}(q) = v_{i,j}^t(q) - c_1^t \times r_{1,i,j}^t$ ;
         $v_{i,j}^{t+1}(z) = v_{i,j}^t(z) - c_1^t \times r_{1,i,j}^t$ ;
      End
      If  $q \neq s$  then:
         $v_{i,j}^{t+1}(q) = v_{i,j}^t(q) - c_2^t \times r_{2,i,j}^t$ ;
         $v_{i,j}^{t+1}(s) = v_{i,j}^t(s) - c_2^t \times r_{2,i,j}^t$ ;
      End
    Next  $j$ 
  Next  $i$ 

```

Figure 35: pseudo-code updating the velocities as from (Izakian et al., 2010)

(Chen and Shih, 2013) designed an approach to solve the university schedule similar to the one from (Shiau, 2011) but gathering the course as 4 slots per day to reduce the dimensions. It still necessitated extensive repair mechanism after each update and the authors couple the PSO with a local search to improve the results. (Wang *et al.*, 2019) proposed an extension of the discrete definition of the search space on the dynamic job shop-scheduling problem, using similar rule as the SPV, and adding a half step to traduce the new permutations into a position having an operational sense. (Mapetu *et al.*, 2019) proposed an approach of the binary version of the PSO for the task scheduling and load balancing in cloud computing. They added a new updating method to minimize the degree of imbalance among the virtual machines and maximize the resource utilization (comparable to a repair process). (Imran Hossain *et al.*, 2019) proposed specific discrete operators to tackle the university scheduling problem, with one of them being a selective search. It however requires a repair mechanism after the update of particles positions. (Rivera *et al.*, 2022) also developed specific discrete operators to propose an approach for the task scheduling on unrelated machines, which is combined with local search to enhance the solutions found.

From the review above, (Izakian *et al.*, 2010) approach seems particularly interesting for our scheduling problem, having a high number of different statuses (delays or cancellation) possible for each flight. Moreover, by further deepening and adapting the method, the potential for including some constraints already during the velocity update seems promising. This

reduces the complexity and computing time for the repair process needed to make a new position being a feasible solution after update.

### 8.1.2.3. Calibration

A literature review of 21 scientific articles (see Table 20) and thesis using the PSO as an optimization method from 2009 to 2022 enabled to observe typical parameters to test and narrow down the calibration's tests needed.

Table 20: Overview of the literature review for the PSO coefficient calibration

Article	Optimization Topic	W	C1	C2	Nb Particles	Topology
(Deroussi and Lemoine, 2009)	Multi-level lot-sizing problem	Geometrical decrease from 2 to 0.64	2	2	60	Gbest (all particles)
(Izakian <i>et al.</i> , 2010)	Grid job scheduling	1	2	2	50	Ring topology
(Shiau, 2011)	University scheduling	Linear decrease from 0.9 to 0.2	0.4	0.6	12	Gbest (all particles)
(Lee and Ponnambalam 2012)	Multi-pass turning operations	Linear decrease from 0.9 to 0.2	0.4	0.6	20	Gbest (all particles)
(Mohammadi-Ivatloo <i>et al.</i> , 2012)	economic dispatch problems	Linear decrease from 0.9 to 0.2	Linear increase from 2.5 to 0.5	Linear increase from 0.5 to 2.5	40, 100, 350	Gbest (all particles)
(Chen and Shih, 2013)	University scheduling	0.8	2	2	30	Gbest (all particles)
(Dang <i>et al.</i> , 2013)	Vehicle routing problem	Decrease such as $w(t) = 0.9^t$	0.5	0.5	40	Gbest (all particles)
(Chih <i>et al.</i> , 2014)	Multidimensional knapsack problem	Linear decrease from 0.9 to 0.4	Linear increase from 2.2 to 1.8	Linear increase from 1.8 to 2.2	-	Gbest (all particles)
(Liu <i>et al.</i> , 2015)	Job shop scheduling	Linear decrease from 0.9 to 0.4	2	2	10	Gbest (all particles)
(El Dor <i>et al.</i> , 2015)	General PSO Study on topology of neighborhood	0.82	1.19	1.19	20	Dynamic Cluster
(Klement 2015)	Resources assignment in healthcare networks	0.6	0.3	0.1	N/10 (with N the number of dimensions)	Gbest (all particles)
(Hassine 2015)	Eco-friendly manufacturing	0.9	0.5	0.5	100	Ring topology
(Madiouni 2016)	Optimization of digital RST structure based controllers	Linear decrease from 0.9 to 0.4	1.19	1.19	N/10 (with N the number of dimensions)	Archive list as MO-PSO
(Patwal <i>et al.</i> , 2018)	Pumped storage hydrothermal system scheduling problem	Linear decrease from 0.9 to 0.4	Linear increase from 2.5 to 0.5, then $c1=2.5$	Linear increase from 0.5 to 2.5, then $c2=0.5$	100	Gbest (all particles)
(Peng 2019)	Urban logistic optimization	$1/(2*\ln(2))-0.72$	$0.5+\ln(2)-1.19$	$0.5+\ln(2)-1.19$	50	Ring topology
(Zemzami 2019)	General PSO Study on topology of neighborhood	Linear decrease from 0.9 to 0.4	2.25	2.25	30	Ring topology
(Mapetu <i>et al.</i> , 2019)	Task scheduling and load balancing in cloud computing	Linear decrease from 0.9 to 0.5	1.49445	1.49445	30	Gbest (all particles)
(Harbaoui Dridi <i>et al.</i> , 2020)	Vehicle routing problem	Linear decrease from 0.8 to 0.5	0.2	0.2	-	Gbest (all particles)
(Miao <i>et al.</i> , 2021)	Cloud computation load balancing	0.4	2	2	200	Gbest (all particles)
(Dinh, 2021)	Predictive maintenance	Linear decrease from 0.9 and from 1.2	2	2	from 50 to 100	Gbest (all particles)
(Rivera <i>et al.</i> , 2022)	Unrelated parallel machines scheduling	0.5	0.5	0.5	1000	Gbest (all particles)

Given rules were often used, tested, and validated:

- **Coefficient of the PSO equations:**  $0 \leq c_1 + c_2 \leq 4$ ,  $c_1 = c_2$  and  $w$  linearly decreasing at each iteration from 0.9 to 0.4. Moreover, several researchers proposed time-varying acceleration coefficient for  $c_1$  and  $c_2$ . Thus, we must define  $w_{Ini}$ ,  $w_{final}$ ,  $c_{1Ini}$ ,  $c_{1final}$ ,  $c_{2Ini}$  and  $c_{2final}$ .

- **Number of particles:** no specific law, but it must be in line with the problem’s dimensions and the computation time limits. An empiric rule (not demonstrated) is that a swarm size is at least 1/10th of the number of the problem’s dimensions.
- **Topology:** in most articles or thesis not focusing on improving the PSO concept itself, the standard topologies used are either the ring or the gbest (communication with the entire swarm). Several PSO experts recommend not using the gbest to avoid too fast convergence. Thus, the recommended topology to start with the PSO is the ring topology (static neighborhood defined during the initialization phase).

## 8.2. Application of the PSO for the Airlines Group Scheduling Problem

### 8.2.1. Adapted Discrete PSO Method

This section aims at deepening the definitions of the particle’s position and velocity as well as explain and illustrate the method to update these at each iteration. The evaluation function to assess each particle’s performance at each iteration is based on the indicators defined in 4.5 weighted through the AHP defined group weights (see chapter 5).

A particle is a vector of size  $1 \times d$ , with  $d$  the number of flights to reschedule. Each dimension of a particle represents a flight.

Table 21: Illustration of a particle.

F1	F2	...	F17	F18
1	10	...	12	10

Each flight can be assigned to different statuses (corresponding to the machines in (Izakian *et al.*, 2010) and as mathematically formalized in section 4.2.1): on-time, cancelled, advanced, or delayed of a given number of minutes. As European airport official times of departure are split in 5-minutes slots, a flight can only be delayed by 5 or 10 minutes but not 8 minutes. Moreover, a flight can be assigned a departure time maximum 15 minutes prior to the initial Scheduled Departure Time (STD) (see section 4.1.11). Table 22 below illustrates an example of all statuses possible in which the maximum delay possible is 300 minutes. The so-called “Max Delay” is calculated for each optimization run according to specific business rules of the airlines’ group (see section 4.1.11).

Table 22: Illustration of the statuses on which a flight can be assigned.

Status	On-time	Cance l	STD - 15min	STD - 10mi n	STD - 5min	STD + 5min	STD + 10mi n	STD + 15mi n	...	STD + Max Delay
Status ID	0	1	2	3	4	5	6	7	...	65



At each iteration, a particle gets statuses affected to each one of its dimensions (=flights). A possible position is illustrated below in Table 21, where flight F1 is assigned to a cancellation slot while F2 is assigned 30 minutes of delay compared to its original time of departure.

The velocity matrix' size is  $m \times d$ , with  $m$  the number of statuses possible in the optimization instance and  $d$  the number of flights included in the optimization window. Its elements are real numbers belonging to  $[-V_{max}, V_{max}]$  (see section 8.1.2 for  $V_{max}$  definition). As proposed by (Izakian *et al.*, 2010), the status having the highest velocity provides the assignment of the flight. This simple mechanism is illustrated in Table 23 with highest velocity in bold. Thus, flight F1 is assigned on the cancellation status while F2 is assigned on the 30-minutes delay status. The velocity matrix is specific for each particle, initialized randomly and updated at each iteration, as from equation Eq. 106 (p. 140).

Table 23: Illustration of a velocity matrix for a particle.

	F1	F2	...	F17	F18
<b>0 (on-time)</b>	0.32	0.25	...	-5.81	4.11
<b>1 (cancel)</b>	<b>8.57</b>	4.51	...	-5.62	2.15
<b>2 (STD-15)</b>	2.3	4.28	...	0.45	0.14
<b>3 (STD-10)</b>	-3.02	-3.71	...	-4.26	0.13
...	...	...	...	...	...
<b>10 (STD+30)</b>	-4.36	<b>6.31</b>	...	-7.38	<b>4.34</b>
<b>11 (STD+35)</b>	2.41	1.25	...	2.87	-2.15
<b>12 (STD+40)</b>	0.21	1.81	...	<b>5.14</b>	0.12
...	...	...	...	...	...
<b>64 (STD+295)</b>	7.25	4.44	...	3.56	-5.09
<b>65 (STD+300)</b>	-2.26	0.26	...	-5.04	-3.78

We have to deal with specific constraints. The first ones are linked to operational constraints such as night curfew at airports (no departure and/or arrival allowed after a certain time, the aircraft must thus operate before or divert to another airport, which disrupt even more the operations), flights subject to the 80/20 airport slots rule or peak times of traffic. Other ones are linked to the rotations of an aircraft: cancellation and reactionary delay for flights operated by the same aircraft (rotations). Finally, the last ones are linked with the problem definition such as the minimum number of cancellations required.

- **Operational constraints such as night ban curfew at airports** (see Eq. 38 and Eq. 39, p. 59): For each flight, the minimum between the night ban curfew time at the departure airport, the one at the arrival airport (minus the flight time) and the maximum delay allowed in the problem is used. If any status is higher than this threshold, it will

be initialized on a specific velocity  $\alpha$  (e.g.,  $\alpha > |V_{max}|$ ), which will not be updated and thus the flight will never be assigned to these statuses (Table 24).

Table 24: Illustration of the curfew limits on a flight with a curfew 35 minutes after STD.

	F1	F2	...	F17	F18
<b>0 (on-time)</b>	0.32	0.25	...	-5.81	4.11
<b>1 (cancel)</b>	<b>8.57</b>	4.51	...	-5.62	2.15
<b>2 (STD-15)</b>	2.3	4.28	...	0.45	0.14
<b>3 (STD-10)</b>	-3.02	-3.71	...	-4.26	0.13
...	...	...	...	...	...
<b>10 (STD+30)</b>	-4.36	<b>6.31</b>	...	-7.38	<b>4.34</b>
<b>11 (STD+35)</b>	$\alpha$	1.25	...	2.87	-2.15
<b>12 (STD+40)</b>	$\alpha$	1.81	...	<b>5.14</b>	0.12
...	...	...	...	...	...
<b>64 (STD+295)</b>	$\alpha$	4.44	...	3.56	-5.09
<b>65 (STD+300)</b>	$\alpha$	0.26	...	-5.04	-3.78

The same principle is used for the flights critical due to the 80/20 airport slot rule. An airline having specific flights cancelled in the operational season more than 20% lose their grandfather rights on the airport slots (see Eq. 46, p. 61). Therefore, under certain conditions, some flights already cancelled a lot within the previous months are not allowed to be cancelled anymore. Thus, the status 1 corresponding to the cancellation is disabled for these flights.

- **Operational constraints such as peak times of traffic** (see Eq. 45, p. 61): a flight initially operated outside of a peak time of traffic is not allowed to be delayed into the traffic peak, which would otherwise overload even more the given airport and lead to increased delay on all flights in the peak time. The mechanism used is the same as for the night curfew constraints: the statuses bringing the flight into a traffic peak are disabled, and no velocities are assigned to these statuses in the initialization phase.

These three main constraints can be defined during the initialization phase of the velocity. Thus, the flights will never be assigned to those statuses falling into a night curfew or traffic peak. This enables saving computation power by avoiding any useless calculations and assignment on unfeasible statuses.

However, as the flights operated by a same aircraft (easily retrievable through the aircraft registration, see section 4.1.3) from and to the hub (same rotation) are interdependent, a repair process is necessary, if the PSO particle is proposing conflicting statuses to flights of a same rotation.

- **Cancellations within a rotation** (see Eq. 44, p. 60): Let us consider two flights belonging to a same rotation. If one is assigned to the cancellation status while the other one is assigned to a delay status, there is a conflict. The flight with the highest velocity on its assigned status will force the other flight on his status. e.g.: *if F1's highest velocity is 8.57 on the cancellation status, if F2's highest velocity is 6.31 on 30 minutes delay status, and if F1 and F2 belongs to the same rotation, then F1 and F2 are assigned to the cancellation status as 8.57 is higher than 6.31.*
- **Reactionary delay** (see Eq. 35, p. 58 and Figure 7 p.58): all flights belonging to a same rotation must be assigned compatible statuses. In the PSO concept, this is translated as: if the flights of a same rotation are assigned incompatible velocities, the status assigned to the flights is the one with the highest velocity.
- **Minimum cancellations required** (see Eq. 41, p. 60): if not enough rotations through the highest velocity principle were assigned to the status 1 (cancellation) as required by the problem definition, then the flights are ordered by decreasing velocity on status 1 and the necessary number of flights (including the flights within the rotation) are assigned on the status “cancelled”.

Through the constraints described in the section, none of them is hampering a feasible solution to be reached. Even if the PSO coefficients are wrongly chosen, the random component can always enable some particles to explore some other parts of the search space.

In our multi-airline operations optimization, the performance assessment of the solutions is defined by the multi-stakeholders AHP. Indicators from the operational, passenger and crew categories (as defined in section 4.5) are calculated at each instance for each particle and weighted through the group weights defined through the group AHP questionnaire (see section 5.2). This is then used to compare their performance with their respective  $pbest_i$  and  $gbest_i$  and update accordingly the velocity for the next iteration, as from Eq. 106 (p. 140).

### 8.2.2. Initialization Strategies

The initialization of the PSO particles can influence greatly the time and iterations necessary to reach good solutions. Some research were recently conducted about that aspect, such as (Bangyal *et al.*, 2021). We first implemented a uniform distribution to initialize the velocity of our particles through the search space. The PSO method defined is quite effective (see part 8.2.3) but tend to assign very high delay to flights with no apparent reason. Thus, to incentive

the particles to first search for solutions with reasonable delay, the velocity is assigned such as the statuses assigning high delays get random values between very small boundaries (e.g., randomly assigned between  $[-2,2]$ ) while the statuses assigning smaller delay gets a random value between bigger boundaries (e.g., randomly assigned between  $[-50,50]$ ). Therefore, the initialization of the velocity stays fundamentally randomized but emphasize an operational reality that flights cannot easily be greatly delayed. This mechanism worked very well, as the results shows it in chapter 10.

The initialization of the chosen static neighborhood is represented on Figure 36, which means that the neighborhood is defined through the particle number and not through its position (which is updated at each iteration). We use the ring topology (see section 8.1.2). The number of neighbors with whom a particle  $i$  can exchange information about the  $gbest_i$  is linked to a parameter to calibrate (see section 8.2.3). On the representation below, the particle  $i$  of a 12-particle swarm is getting information from 6 particles, 3 “before”  $i$  and 3 “after”  $i$ . Instead of a 6-particle neighborhood, it could also be for example a 4-particle neighborhood, with 2 “before” and 2 “after” particle  $i$ , or a 2-particle neighborhood with 1 “before” and 1 “after” particle  $i$ .

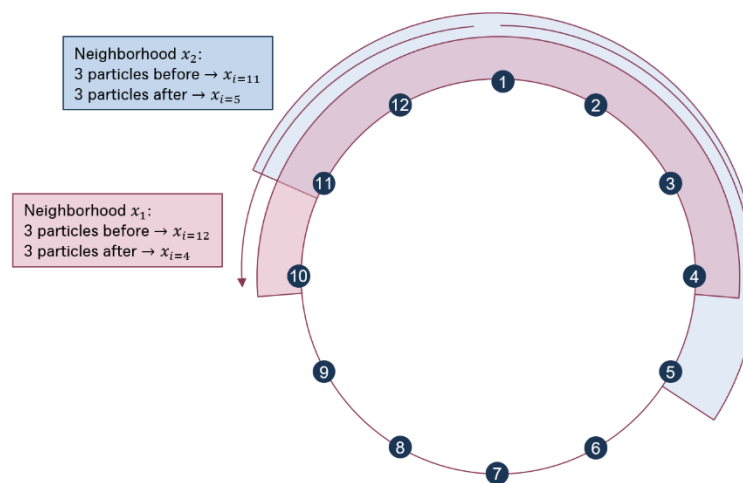

Figure 36: Illustration of the ring topology with 6 neighbors per particles.

### 8.2.3. Calibration

A calibration in several rounds took place on data set from a real operational case from 2019, with 18 flights to re-schedule. First, a large-scale calibration relying on the literature review outputs (section 8.1.2.3) took place. Based on the learnings of this large-scale calibration, a calibration extension was proposed to explore and confirm some hypothesis. This highlighted

some behaviors linked to specific PSO parameters and a last small-scale refinement of the calibration confirms the parameters to use and illustrates on two examples its efficiency.

The large-scale calibration tested 2,200 parameters combinations (see Table 25). Not all possible combinations were tested, as each one needs around 1 minute to be computed (>36 hours in total). While some articles in the literature recommend using a swarm size of at least  $1/10^{\text{th}}$  of the problem dimension, we can observe (Table 20, p. 146) that all articles use more than 10 particles, even for similar problem size than the 2019 use-case. Thus, the minimum swarm size is 10 particles and different sizes are tried out. To avoid an early convergence towards a local optimum, we start with a small size for the ring topology neighborhood.

Table 25: Table of parameters and ranges to test during the PSO calibration.

Parameters	Smallest value	Highest value	Step of increase	Number of scenarios needed	Specificities
$w_{Ini}$	0.6	1	0.1	5	W to decrease linearly from $w_{Ini}$ to $w_{final}$
$w_{final}$	0	0.4	0.1	5	
$c_{1Ini}$ & $c_{2Ini}$	0.5	1.5	0.1	11	$c_1$ and $c_2$ to increase linearly to $c_{1final} = c_{2final} = 2$
Number of particles	10	25	5	4	
Number of particles connected in the ring	-1/+1	-2/+2	-	2	

The outputs from the first large scale calibration showed good results with  $w_{Ini} = 1$  and the smallest difference between  $w_{Ini}$  and  $w_{final}$  (captured by the linear coefficient  $a_w = \frac{(w_{Ini}-w_{final})}{Nb_{Iterations}}$ ). It also showed that a ring topology with the particle  $i$  exchanging information with two particles “before” and two “after” reached better results (see section 8.1.2 for neighborhood definitions). Moreover, the higher the  $c_{1Ini}$  and  $c_{2Ini}$ , the better the results. Concerning the size of the swarm, it is very much related to the neighborhood size. However, a 25-particle swarm is converging too fast and thus is excluded from further tests. More details can be found in Appendix D.

Based on these learnings, an extension of the calibration with 288 combinations took place to enable fine-tuning of the settings for the parameters (see Table 26). This allows to complete the large-scale calibration with new tests: fixing  $w_{Ini}=1$ ,  $0.4 \leq w_{final} \leq 1$ ,  $c_{1Ini} = c_{2Ini} \geq 1.7$ , and exploring slightly bigger neighborhoods (from -1/+1 to -4/+4).

Table 26: Parameters tested within the refinement calibration.

Parameters	Smallest value	Highest value	Step of increase	Number of scenarios needed	Specificities
$w_{Ini}$	1.0	1.0	0	0	W to decrease linearly from $w_{Ini}$ to $w_{final}$
$w_{final}$	0.4	0.9	0.1	6	
$c_{1Ini}$ & $c_{2Ini}$	1.7	2	0.1	4	$c_1$ and $c_2$ to increase linearly to $c_{1final} = c_{2final} = 2$
Number of particles	10	20	5	3	
Number of particles connected in the ring	-1/+1	-4/+4	-	4	

The extension of the parameters' calibration confirmed the following point: the smaller the difference between  $w_{Ini}$  and  $w_{final}$ , the better the performances. A similar trend, although less clear, was observed for the difference between  $c_{1Ini} = c_{2Ini}$  and  $c_{1final} = c_{2final}$ . A 15-particle swarm with a ring topology of 6 neighbors (-3/+3) was identified the most efficient.

A last test was conducted, with static  $w$  and  $c_1 = c_2$  coefficients, which showed very good results (an interesting comparison with slight linear evolution of the coefficients can be found in Appendix D). A last pass to fine-tune the static  $c_1 = c_2$  coefficient was performed, with 1.5 being the best value. The chosen parameters following the calibrations outputs are:

- Number of particles in the swarm: 15,
- Topology model and number of neighbors: ring topology with 6 neighbors (3 before particle  $i$  and 3 after, see Figure 36)
- $w_{Ini} = w_{final} = 1$ ,
- $c_{1Ini} = c_{2Ini} = c_{1final} = c_{2final} = 1.5$ ,

Figure 37 shows a good convergence of the particle's best-known performance (and their neighbors) towards the optimum solution represented by the brown line with this set of parameters (called in the graph GBT). The optimum solution in the calibration is easily calculable on small size-problems where the evaluation function is simplified (linked linearly to the delay attributed to the flights). Figure 38 shows the evolution of the particles' performances through the iterations. The particles are exploring greatly the search space (4,115 different positions of the existing 5'505 possible ones according to the number of particles and

iterations, which corresponds to a 74% of exploration rate) and converging towards positions reaching lower – thus better – performances.

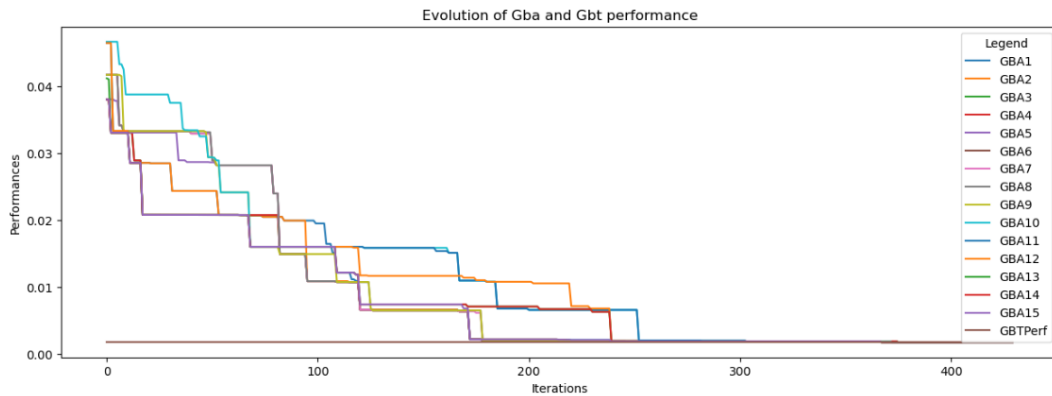

Figure 37: Evolution of  $gbest_i$  found by each particle and its neighbors versus the theoretical optimum (brown line – GBT)

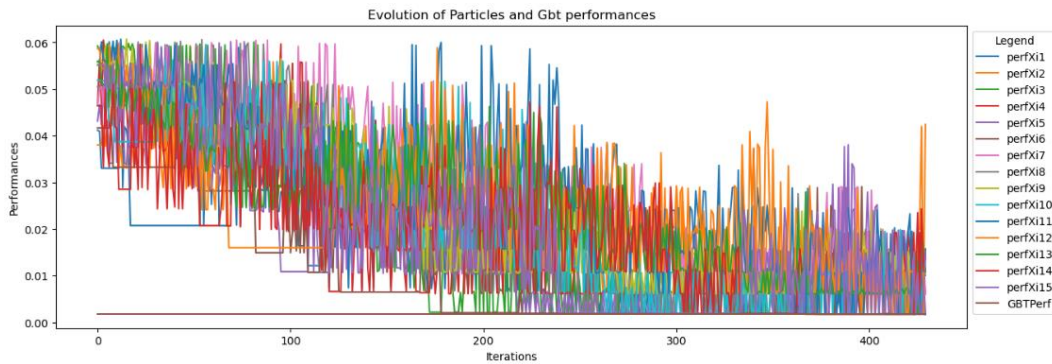

Figure 38: Particles positions performances evolution.

The running time requirements from the users being 2 minutes, and up to maximum 5 minutes in case of large disruption, and the calibration being done on a small-scale problem (18 flights), the optimization time allocated to the PSO optimizer was 1 minute. It was tested and validated beforehand that it let enough time to the optimizer to converge towards very good solutions within this 1-minute timeframe, to not bias the calibration. In average, within 1 minute, the optimizer was able to reach around 400 iterations and – for the right parameters set – to have the best positions known by all neighborhoods converging to the theoretical optimum position. The second termination parameter of the PSO was thus reaching 700 iterations.

### 8.3. Chapter Conclusion

After a short review of the individual-based metaheuristics, the literature review focused on the population-based metaheuristics as the individual-based methods are not adequate to achieve efficient exploration of the search-space in a limited time. Evolutionary Algorithm – especially Genetic Algorithm (GA) –, Ant Colony Optimization (ACO) and Particle Swarm Optimization (PSO) were introduced and briefly compared. The PSO has an advantage over the GA that the computation time can be faster, as the update of the PSO equations requires

less heavy computation tasks than the mutation and crossover techniques of the GA (if the PSO particles are smartly defined to limit requirements for repair mechanisms). No real consensus on using the ACO and the PSO for scheduling problem exists. However, the majority of articles on scheduling problems outside of the aviation field recognize the higher efficiency of the PSO. As from our knowledge (see section 2.1), the PSO never has been applied to the airline scheduling problem. We propose in this thesis to develop a first approach using the Particle Swarm Optimization method for solving schedule, including cancellations and delays into the recovery problem. PSO is shown to be well suited, and quite easy to define and explain.

Within the PSO, a very important step for the success of the algorithm is to define the position and the velocity updates. The scheduling problem being a discrete one, several methods tackling discrete PSO were reviewed. We choose to base our particle definition and equations update on (Izakian *et al.*, 2010) approach, which is quite successful in efficient search space with limited computing time.

We proposed an efficient and interesting Particle Swarm Optimization adaptation to the airline-scheduling problem. It enables a group of airlines to find the best combination of cancellation and delays on all their flights in a limited time. The smart initialization of the velocity enables the particles to explore operationally interesting solutions as from the beginning. The judicious constraints consideration in the initialization phase, enables to reduce the solutions' repair process needed at each iteration in case of non-feasible solutions proposed by the PSO. This thus provides a computing-time efficient adaptation of the PSO to our multi-airline operations optimization problem, being the first proposed, as from the author's current best knowledge.

The solutions proposed by the PSO must be assessed with a group vision. we decided to use a macro indicator based on the AHP weights for the PSO method, as the group vision could not be properly defined through a MOPSO (Multi Objective Particle Swarm Optimization), as well as avoid the early convergence problem of it (see chapter 5)

Finally, the calibration and initialization strategies to make the proposed approach of the PSO suiting the users' requirements in terms of solution quality and computing time was presented, with very satisfying results. Now that the flight recovery problem is presented, the integration of the passenger problem is defined and tackled in the next chapter.



## 9. Passengers Optimization Approach

To assess if a schedule proposed by the PSO is a good solution, the passenger recovery problem must first be optimized. Then, all the indicators defined in section 4.5 are calculated and gathered thanks to the group AHP weights to provide an assessment of the solution. Thus, the passenger optimization is imbricated into the schedule optimization.

Two approaches for the passenger optimization are proposed in this chapter. The first one, referred as the “quick passenger optimization” is an estimation rather than an optimization. It is based on a logic assigning the passengers to the available seats to estimate quickly whether a proposed planning is promising for the passengers or not. It calculates the upper bound of the costs incurred by passengers with no solutions or with costly solutions (downgraded or arriving later than the EUC261 thresholds). It corresponds to the worse possible impact of the planning for the disrupted passengers (task P3.2 on Figure 39).

Once the particles swarm explored enough the search space and converged to a few optimal solutions, the planning proposed by those solutions are optimized accurately through the so-called “accurate passenger optimization” (task P3.4 on Figure 39). The results out of this are assessed through the group AHP and presented to the user for a choice (see chapter 6).

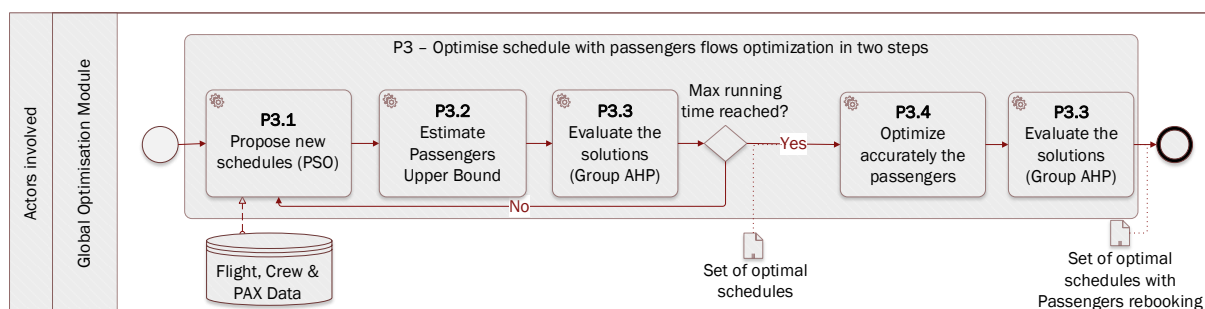

Figure 39: Business Process Model Notation for P3 with a two-stage passenger optimization.

The passengers to optimize are only the one disrupted by the new planning. Those are the passengers on cancelled flights in the new schedule, or the passengers on delayed flights such the minimum connecting time to catch their next flight is not guaranteed. Those disrupted passengers are grouped in passenger flows defined by their origin and destination airports, their arrival time at destination, and their booking class. For each flow, alternative itineraries are gathered before the optimization starts. It is considered as entry data (see section 4.1.9). These

data are coming from the Amadeus multi-availability request used by most of airlines, which provides all existing alternatives per origin and destination pair.

## 9.1. Quick Passengers Optimization Method

### 9.1.1. Method Developed

As explained in the introduction, the quick passenger optimization is a basic approach aiming at estimating quickly the upper bound of the passengers with costly or no solutions for the proposed planning. The logic goes flow by flow (ordered by descending importance, which is calculated based on the flow number of passengers and their initial booking class). It checks the seat availability of each existing alternative itinerary for this flow, and allocate the reservations (ordered by descending importance, also calculated according to the number of passengers and initial booking class) one by one according to the number of passengers per reservation. The passengers of a same reservation cannot be split on different alternatives. It also checks the arrival delay at the planned destination and identify the delay above the EUC 261 thresholds. It is worth noting that for the quick passenger optimization, the flows are

```

Inputs Data: Get all disrupted Pax reservation aggregated by flows by origin,
destination, booking class (see section 4.1.8). //Pax = passengers;
For Each flow f:
    Get all alternative itineraries possible for the flow f (see section 4.1.9);
    For Each alternative a:
        Assign max (available seat on a, Pax to rebook) Pax on a;
        Update number of down/upgraded Pax according to initial booking class
        and assigned seats class;
        Update flight availability according to assigned Pax to a;
    Next a
    For Each Pax reservation p in f, ordered by importance:
        If (number of Pax in p < max (upgraded Pax, downgraded Pax))
            Update reservation Status to SolutionFound;
            Upgrade reservation newBookingClass according to
            down/upgraded Pax number left;
            Update down/upgraded Pax number according to the reservation
            assignment;
        Else
            Update reservation Status to NoSolutionFound;
    Next p
Next f
Calculate global costs based on passengers with no solutions, down/upgrade costs and
alternative with arrival time later that the EUC 261 threshold;
Outputs Data: global costs + all reservations with Status updated, alternative itineraries
assigned and corresponding newBookingClass assigned (if any).

```

Figure 40: Pseudo-Code assigning passengers to alternative itineraries.

gathered by date of arrival rather than exact time (less different flows to consider, thus less computing time needed). A basic pseudo-code is presented below on Figure 40.

### 9.1.2. *Illustration on an Example*

Let us consider a small-scale problem, in which two flows of passengers are considered, both from Bangkok (BKK) to Paris (CDG). Flow A is composed of 5 passengers in business class, while the flow B is composed of 7 passengers in economy class. The flow of business class passengers is considered more important and therefore its passengers are rebooked first. To have an illustration of the different alternatives and costs, the reader can refer to the graph Figure 44, p. 163. Three alternative routes exist:

- LH773 from BKK to MUC (Munich) with 3 free seats in business class and 3 free seats in economy class, connecting either with:
  - LH1026 to CDG with 2 free seats in economy class
  - LH1034 to CDG with 4 free seats in economy class,
- LX181 from BKK to ZRH (Zurich) with 3 free seats in business class and 4 free seats in economy class, connecting either with:
  - LX634 to CDG with 4 free seats in economy class,
  - LX636 to CDG with 1 free seat in business class and 2 free seats in economy class.

The downgrading costs can be avoided for only 1 passenger of flow A, with rebooking in business class on the two flights LX181 and LX636. Then, 2 passengers are rebooked on LX181 in business and LX634 in economy, to limit the delay costs, while the 2 last passengers are rebooked on LH773 in business and LH1026 in economy. As the downgrading costs are linked to the main leg, which is the long-haul one, this is the less costly solution. For Flow B, 3 passengers are rebooked in economy class on LH773 with connection on LH1034, while the four other passengers are rebooked in economy class on LX181, with 2 connecting on LX634 and 2 on LX636.

The efficiency of the method and its results are discussed and compared with the accurate passenger optimization method in section 9.3. The goal of this quick passenger optimization is to assess, in the shortest time possible, a good estimate of the upper bound of costs. As the

calculations are quite simple, it is rather fast to compute, however, this consideration by flow priority can lead to inefficient use of the available capacity of the flights.

## **9.2. Accurate Passengers Optimization Method**

### ***9.2.1. Method Developed***

As for the “quick” passenger optimization presented in section 9.1, the passengers are gathered by flows with same origin, destination and booking class. As shown in the literature review of the passenger recovery problem (section 2.2), most of the passengers flows optimization problems are efficiently solved thanks to mixed integer programming solver based on graph representation. A common approach is to represent the passengers flows as a directed acyclic graph as the passengers cannot connect backward in the time. Passenger flows’ origins, destinations and flights are modelled with nodes, arcs are feasible connections with capacities (seat availability on the flights) and costs per unit allocated to this arc (due to down/upgrade costs, delay costs). The passenger problem is modelled as a variation of the minimum-cost multi-commodity network flow problem. The graph that we propose below is based on the modeling of (Acuna-Agost *et al.*, 2015). One of the main differences is that the authors were constructing the graph as from the flight network they had, while in our approach, only the feasible alternatives with seat availability are considered.

As the passengers flows to and from the disrupted airport usually do not share any common flights, the problem is separated into two independent problems: the graph “In” corresponds to the graph of passengers flows to the disrupted airport, and the graph “Out” correspond to the graph of the passengers flows from the disrupted airport. The graphs modeling are different due to the up/downgrade costs that are not allocated to the same kind of arcs in both graphs. In graph “In”, only the start of the passenger flows is modelled – called flows’ source nodes – while in graph “Out”, only the end of the passenger flows is modelled as nodes – called flows’ sink nodes –, each one connected to the virtual sink node.

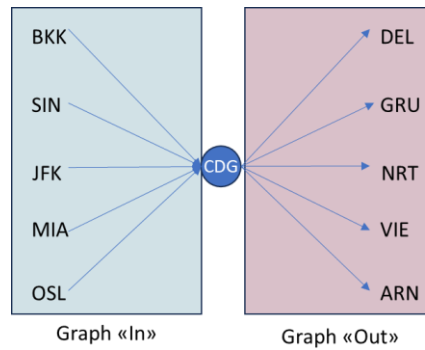

Figure 41: Illustration of the flows split from/to the disrupted airport CDG.

The following paragraphs will explain step by step how the graph “Out” is modelled. The graph has a source node (the disrupted airport, in our example Charles de Gaulle – CDG – which is node 0) and a virtual end node (node 4). Each flow is modelled as a node with a demand corresponding to the number of passengers to rebook from the flow (nodes 1, 2 and 3, with their corresponding grey box on Figure 42). A direct arc joining the virtual source node and the flow’s node corresponds to the cancellation of the itinerary (red arcs on Figure 42). Its capacity is infinite (all passengers reservations of the flow could be cancelled if no alternative exists) with costs corresponding to the cancellation costs linked to the initial booking class of the flow. On the example below, the costs for cancelling a flow of economy class passengers are 500 against 1350 for business class passengers.

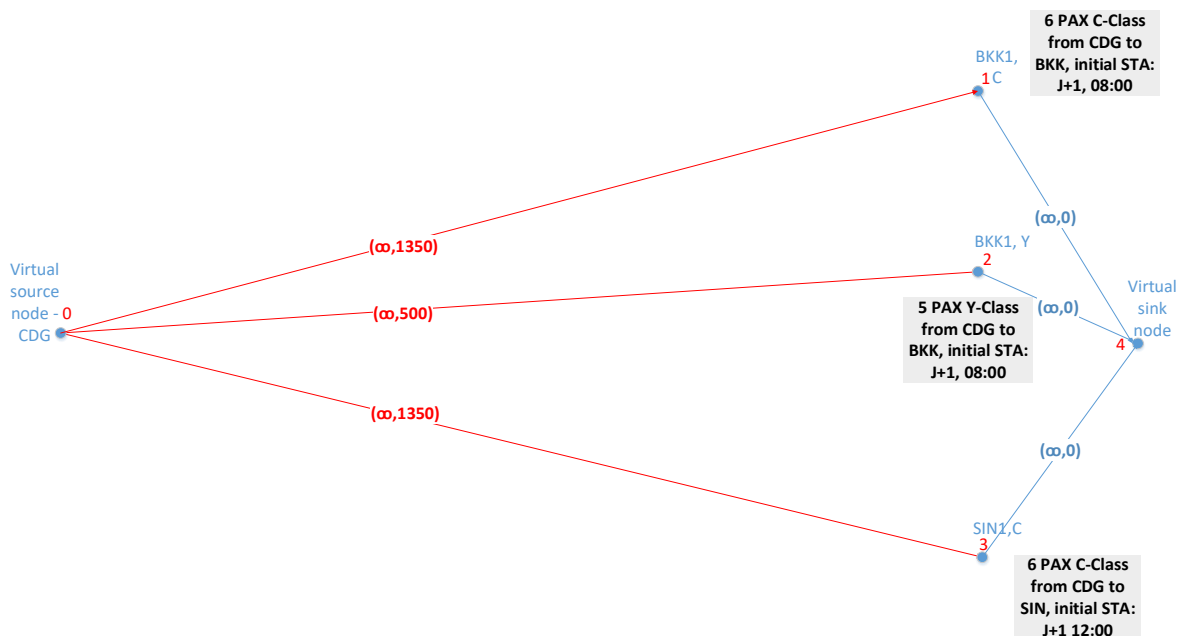

Figure 42: Graph "Out" Creation - first step: flows' nodes and cancellation arcs.

Each flight is modelled by a departure node (such as nodes 5 on Figure 43) and an arrival node (node 6 on Figure 43). As each flight is having different booking classes (see section 4.1.5 and

4.1.6), a flight is modelled as different and independent nodes per booking class. Thus, nodes 5 & 6 corresponds on the flight LH1 for the business class and nodes 7 & 8 corresponds to the flight LH1 for the economy class. The arcs (in orange) connecting the flight’s departure node to the flight’s arrival node is having a capacity equivalent to the number of seats available on this flight for the given booking class, and a cost of 0. Each flight’s departure node is connected to the virtual source node (if it is the first flight of the alternative) or to the arrival node of the precedent flight (if not the first flight of the alternative). These arcs have an infinite capacity and a cost of 0 if the flights are not the last ones of the alternative. This corresponds to the arcs in blue (for the flows to Bangkok – BKK), in green (for the flows to Singapore – SIN) and black (for the connections between flights) on Figure 43.

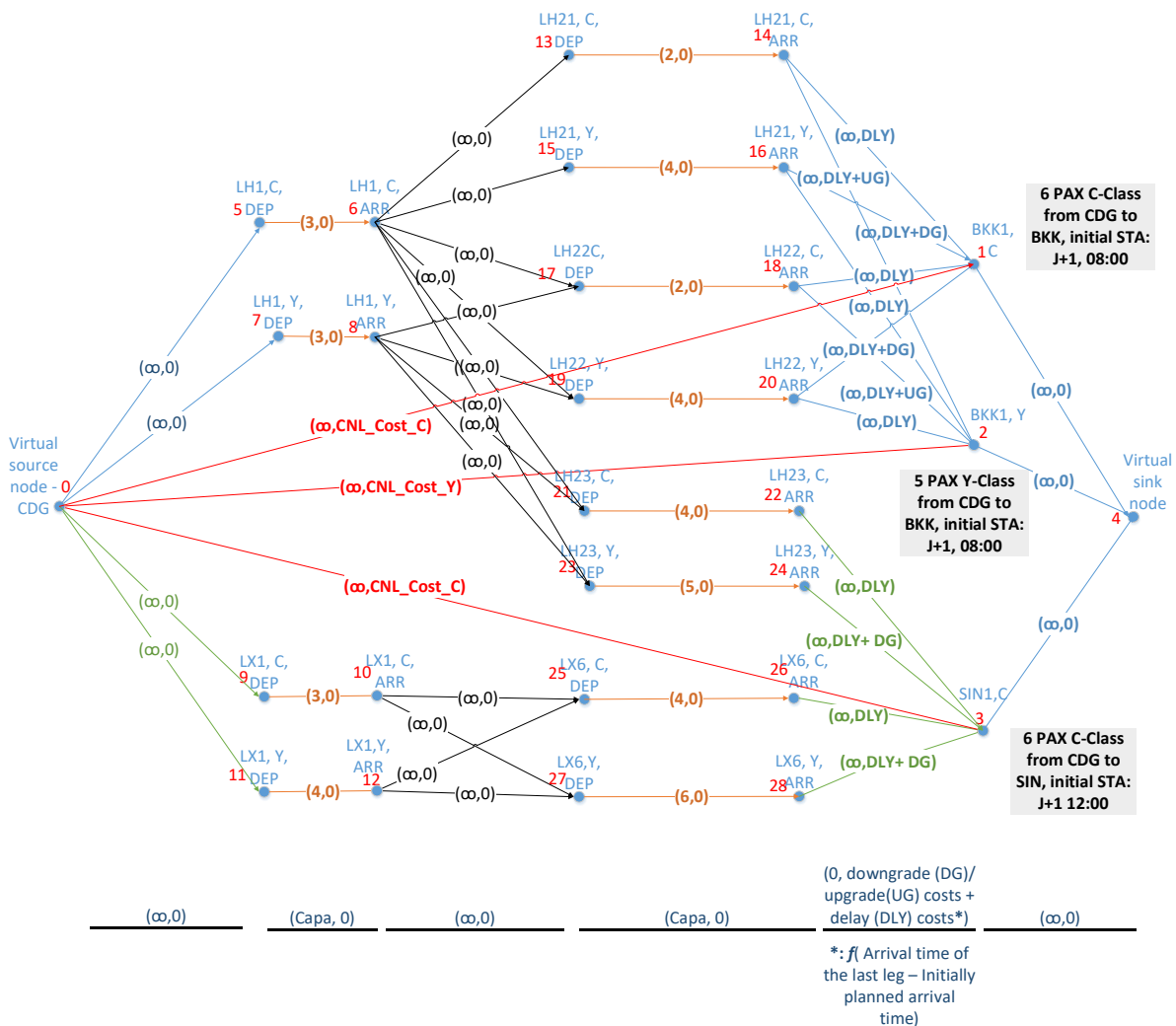

Figure 43: Graph "Out" Creation - final step: flights nodes and connecting arcs.

Finally, the arcs between the arrival nodes of the last flights of the alternatives and the flows’ nodes are the ones on which the costs are calculated (illustrated in blue and green on Figure 43). In the case of the graph “Out”, as the disrupted airport is a European one, the last flight is

the long-haul flight. Therefore, it is the reference for down/upgrade costs (noted “DG” and “UG” on the arcs on Figure 43). For example, the arc connecting node 14 (flight LH21 for business class) to the node 2 (node for the flow of passengers initially booked in economy class to Bangkok) is subject to upgrade costs (as the passengers initially booked in economy class are assigned on LH21 in business class) and potential delay costs (noted “DLY”), if LH21 is arriving later than the initial arrival time of the flow (as from the example, J+1 at 08:00). Arc from node 14 to node 1 (node for the flow of passengers initially booked in business class to Bangkok) has no down/upgrade costs as node 14 is the arrival node of LH21 for business class. Arc from node 16 to node 1 has upgrade costs as connecting the arrival node of flight LH21 for economy class to the flow of passengers initially booking in business class.

As stated before, the Graph “In” is a bit different due to the cost assignments on the arcs. First, it must be noted that the flows’ nodes (nodes 1 & 2 on Figure 44) must be linked to the departure nodes of the first flights of the alternative itineraries. Indeed, the first leg is the long-haul one (for the reservations with intercontinental journey towards a European airport) and therefore the reference for the up/downgrade costs. It must be thus known if the flows arriving in nodes 4, 6, 8 or 10 are initially business or economy booked passengers, to calculate accordingly those up/downgrade costs. As the flows nodes must be at the “beginning” of the graph and not anymore at the “end”, the costs of delay are modified and must be split in two. The information for the initial Scheduled Time of Arrival (STA) of the flow is located on the flows’ node, which means at the beginning of the graph (for Graph “In”). The information on the arrival time of the last leg of the alternative itineraries, though, is located on the arrival node of the last flights. No direct delta between the initial STA of the flow and the arrival time of the last flight of the alternative itinerary is calculable anymore. Therefore, a reference time is needed, and can be typically the end of the operational day, at 23.59. The deltas are calculated in two steps on two different types of arcs. The arcs have infinite capacity, with costs are defined as follows (illustrated on Figure 45):

- The arcs between the virtual source node (node 0) and the flows’ nodes (nodes 1 & 2) assign the delay costs related to the delta between the referent time and the initial STA of the flow (in blue and green on Figure 44);
- The arcs between the arrival node of the last flights of the alternative itineraries and the virtual sink node assign the delay costs related to the delta between the arrival time of the last flight and the referent time (in purple on Figure 44).

Moreover, the cancellation arc (in red) is linking the flows nodes to the virtual nodes. This is illustrated on Figure 44 below.

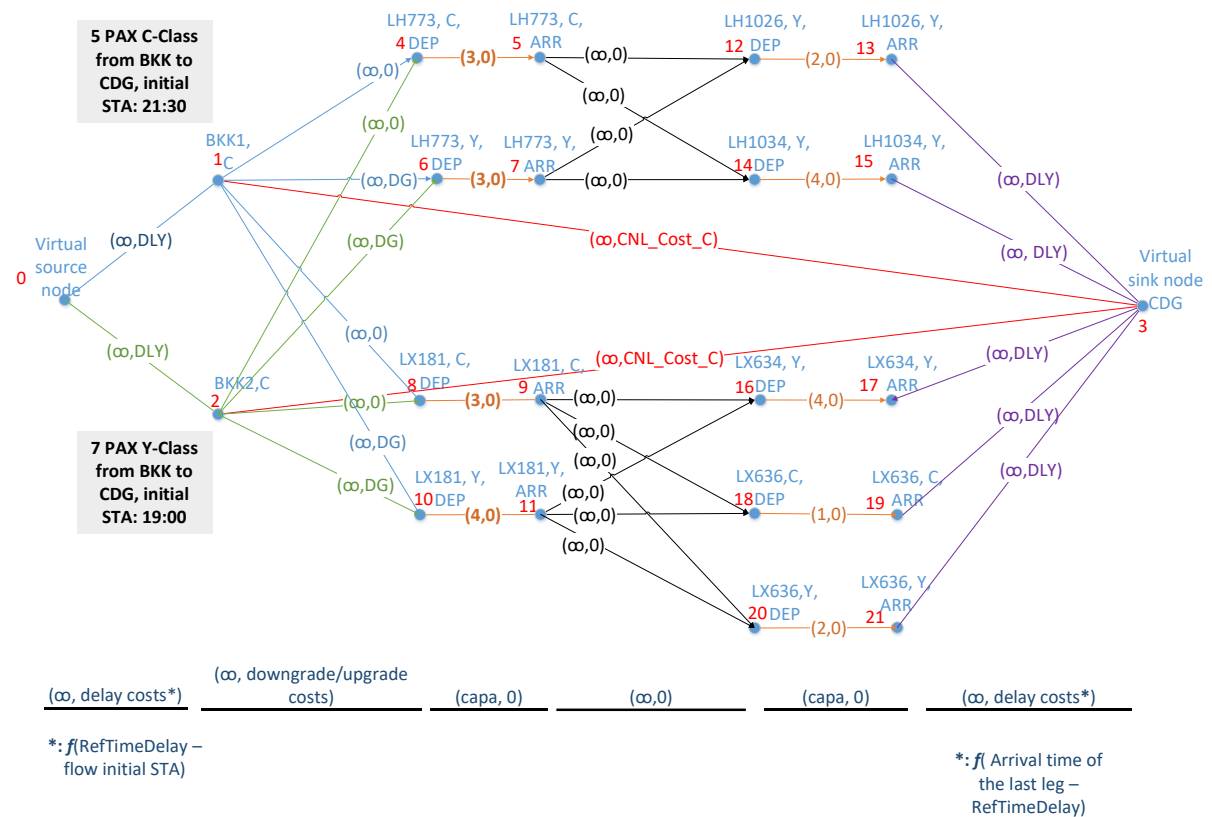

Figure 44: Graph "In" - Illustration on a simple example.

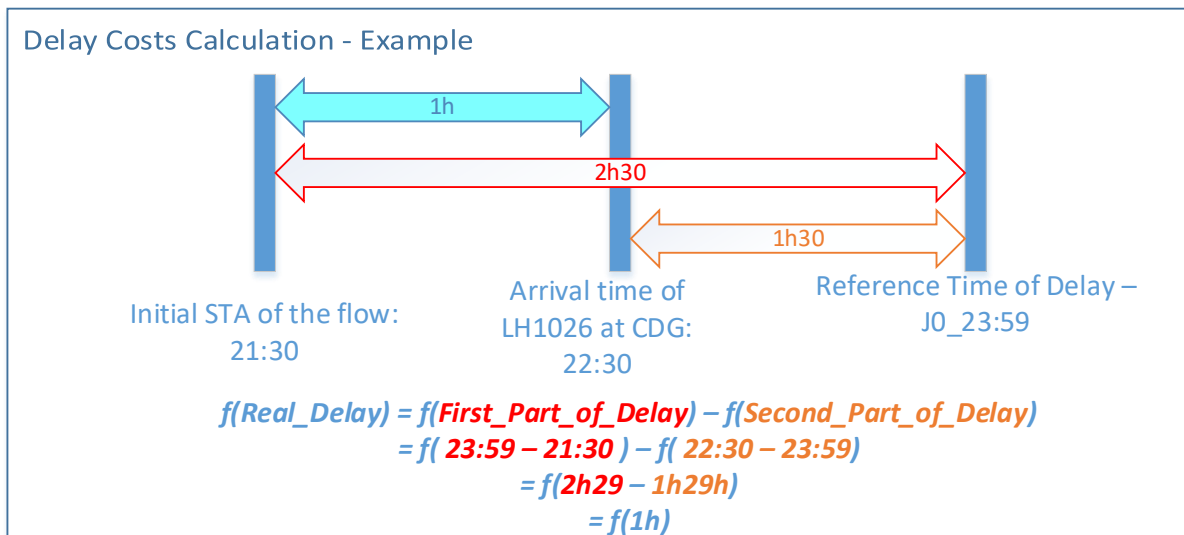

Figure 45: Illustration of delay calculation on a basic example.

Due to the delay costs split in two in the Graph “In”, a linear approach for delay costs modeling is used. Works of great importance were published by ((Cook *et al.*, 2012), (Cook, 2015), and (Cook *et al.*, 2021)) to propose a modelling of the costs of delays. Even if these evaluations are



not precise enough to model real operational costs (that only each airline could try to compute internally), these estimations of the costs of delay are used by most of the researcher nowadays to better model the operational delay costs and notably more realistic objective functions. These enable an acceptable linearization of the delay costs for research purposes, and we will rely on it to further model the delay costs in our passenger optimization approach.

Most of the article and thesis proposed in the field of operational research do so. An accurate modeling of the delay is quite difficult if not all data are available (which is our case), and therefore many researchers approximate the costs of delay as a linear cost. While this approximation is accepted by the airlines for early deployment and validation purposes, it should be refined – if the airlines are truly able to estimate better their costs– for a system implementation.

To solve the multi-commodity minimum-costs maximum flows problems, several solvers exist on the market. Gurobi CPLEX solver is used in many articles presented in section 2.2, however it is restricted to university student usage only. The Google OR-Tool Solver, proposing a minimum cost flow solver in the graph library<sup>10</sup>, is a free of charge solver with no specific usage conditions. The project being under the ownership of SWISS, the Google OR solver was chosen. The minimum cost flows solver receives the graph definition as four arrays for the start nodes, end nodes, capacities, and unit costs. The length of the arrays corresponds to the number of arcs in the graph. Additionally, an array defining the supplies or demand at each node is sent to the solver. The solver is an algorithm based on (Goldberg, 1997) and (Bünnagel *et al.*, 1998).

It must be noted that the solver returns the best solution found (in our case, minimizing the total costs of passenger assignment on alternative itineraries or cancellations) but does not ensure that the solution is optimal.

### 9.2.2. *Illustration on an Example*

Let us consider the small-scale problem of section 9.1.2 and illustrated on Figure 44, with two flows of passengers from Bangkok (BKK) to Paris (CDG). To keep the array readable, only the arrays for the flow A (5 passengers in business class from BKK to CDG) and the alternatives linked with LH773 are represented in Table 27.

---

<sup>10</sup> [https://developers.google.com/optimization/reference/graph/min\\_cost\\_flow](https://developers.google.com/optimization/reference/graph/min_cost_flow)

Table 27: Example of arrays for solving the minimum cost flows problem.

<b>Start Node</b>	0	1	1	4	6	5	5	7	7	12	14	13	15	1
<b>End Node</b>	1	4	6	5	7	12	14	12	14	13	15	3	3	3
<b>Capacity</b>	999	999	999	3	3	999	999	999	999	2	4	999	999	999
<b>Unit Cost</b>	DLY	0	DG	0	0	0	0	0	0	0	0	DLY	DLY	CNL

Depending on the values of the delay cost (here referred as DLY, and that are linked to the number of minutes of delay), the downgrade costs (referred as DG) and the cancelation costs (referred as CNL), the solver will find the solution minimizing the costs and allocating the supply as defined on Table 28.

Table 28: Example of the supply array

(Node)	0	1	3	4	5	6	12	13	14	15
<b>Supply</b>	0	5	-5	0	0	0	0	0	0	0

### 9.3. Comparison of the Methods

This section presents the calibration to compare the estimation of the upper bound calculated by the quick passenger optimization in comparison with the accurate passenger optimization. The comparison was done on the total costs, as this was representing the aggregated results of the two approaches. Indeed, the same costs for up/downgrading and delay were used as a basis.

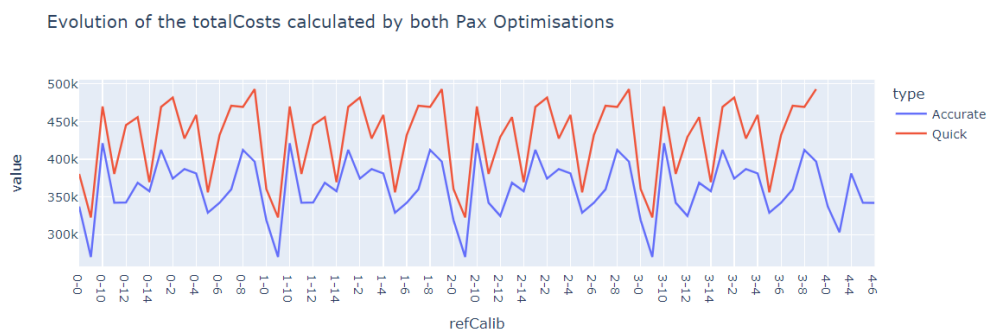

Figure 46: Total costs evolution for both quick and accurate passenger optimizations (without delay costs).

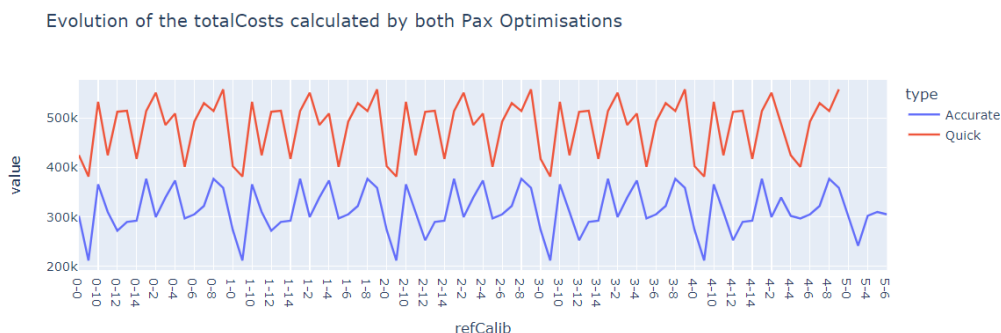

Figure 47: Total costs evolution for both quick and accurate passenger optimizations (with delays costs).

Without considering delay costs, the trend is quite satisfying, with a relative error of around 18% (see Figure 46). However, when comparing with the delay costs considered, the relative

error raised up to 55%, with a trend that is less similar (see Figure 47). The red curve, representing the total costs based on the quick optimization outputs, always presents higher costs than the blue curve, representing the total costs based on the outputs of the accurate optimization. This is the behavior searched for an upper bound. Indeed, the goal of an upper bound is to calculate what would be the worse situation for the passengers with the proposed schedule, and how much would be the expected upper limit of total costs. The delta between the total costs of the quick and accurate optimizations lies in the fact that the quick optimization finds less suitable rebooking for the passengers than the accurate optimization.

The goal of the quick passenger optimization was that the accurate passenger optimization was supposed to be quite heavy with computing time. This would have made impossible to provide interested solutions within the short optimization time required by the users. However, through multiple and extensive code optimization sessions, both approaches have quite similar computing time (around 0.02s per solution). After numerous testing and different methods tried out for the calculation of the upper bound, it was decided to remove the upper bound estimation and use the accurate passenger optimization integrated it in task P3 instead of P3.2, as the computation time was drastically reduced thanks to optimized code.

#### **9.4. Chapter Conclusion**

This chapter proposed two methods approaching the passengers' problem. The first one, called "quick reallocation of passengers" is the estimation of an upper bound of the total passenger costs. It can be up/downgrading costs, delay costs due to delay over the EUC261 thresholds or cancellations fees. The second one, called "accurate passenger optimization" is modeling the passenger problem as a minimum costs maximum flow problem, solved thanks to an open-source solver. The mitigated results of the upper bound calculations combined with the impressive computation time reduction achieved through code optimization and parallelization lead to change the initial structure of the schedule and passenger optimization (corresponding to Figure 39, p.156) for a direct integration of the accurate passenger optimization within the schedule optimization.

The new structure is illustrated on Figure 48.

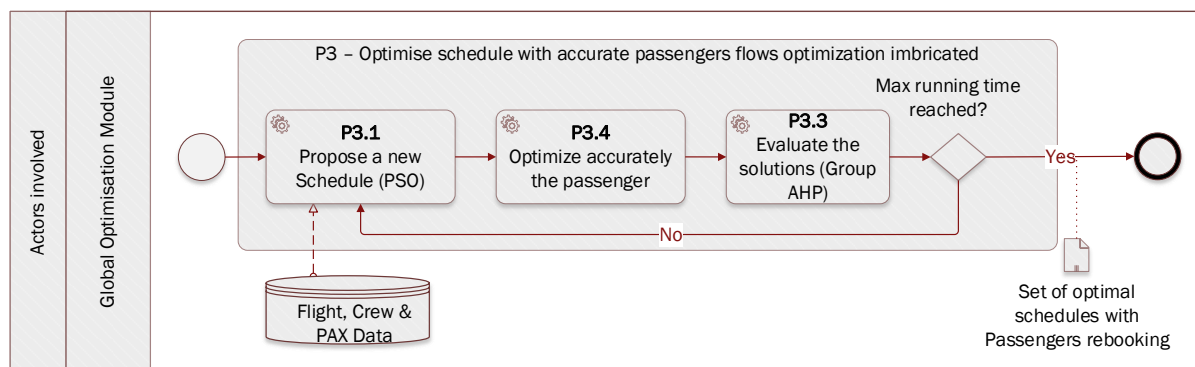

Figure 48: Business Process Model and Notation for P3 with integrated schedule and accurate passenger optimizations.

Indeed, the goal of the accurate passenger optimization is to find a feasible rebooking for most of the passengers with the least costs possible. The costs can be due to up/downgrading of the passengers, delayed arrival at destination causing compensation fees, or cancellation of the itinerary on the planned day if no solution was found (meaning ticket compensation, hotel night at the costs of the airline, etc.). A trade-off of simplifications and operational details was necessary. One of the best examples is the linear expression of delay costs. Real operational costs are not linear with minutes of delay. This is however a simplification used by many researchers of the field, as no information nor data are existing on the true cost structure of delay. This is also the case for this thesis. The up/downgrading costs are occurring on the longest flight in case of connections. This means that if the disruption is a European airport (not being any hub of the airline group), the passengers flying to this airport have their longest flight being the first one of their journeys from their origin airport while the passengers flying from this European airport have their longest flight being the last one of their journeys. Thus, two slightly different graphs were modelled in the accurate passenger optimization to enable a better definition of the up/downgrade costs. This was possible thanks to the two flights not interacting with each other.

For an implemented system in operations aiming at finding a true optimal solution, the modeling of the delay costs should be more accurate. This is a path for future research: either proposing an improved accurate passenger optimization or develop another approach solving with better costs functions the passenger flows rebooking among all airlines' flights. Other projects internal to SWISS are on development to propose a more accurate modeling of the passenger problem as well as on the cost functions based on more data than what was accessible for this PhD. Therefore, we used the accurate passenger optimization to validate our multi-airline operations optimization approach, but this part could be enhanced in the future with the developments of those parallel research or projects.

Finally, each new schedule proposed by the PSO is optimized through the accurate passenger optimization. This gives a solution. Each solution is then evaluated through the macro-indicator with the group vision thanks to the AHP group weights (see chapter 5), and the assessment is used to initiate the next PSO iteration.

---

# Application on an Industrial Case

---

## 10. Global Optimization Module: Concept Validation on an Industrial Use-Case

This part aims at illustrating the methods discussed in the precedent chapters that were developed, tested, and coded to create the Global Optimization Module (GOM). The GOM is a prototype with almost all parts coded in C# to enable demonstration and validation on industrial use-cases.

The final Business Process Model and Notation of the final proposed method is illustrated on Figure 49. The GOM prototype was developed for all processes described. Any optimization starts with the definition of the disruption (task P1) and the possibility for the airlines to input their priorities (task P2) through a dedicated user-friendly User Interface (UI). Then, the core optimization can start (task P3 detailed on Figure 48). The GOM Optimizer searches through many different combinations of cancellations and delays among the group flights, to find the best new schedule, using the Particle Swarm Optimization (as explained in chapter 8). Each new schedule is optimized to find the best solutions for the passengers in terms of rebooking (as explained in chapter 9). Each new schedule with the optimized passenger flows is assessed through the group macro-indicator, defined thanks to the presented Analytic Hierarchy Process method (in chapter 5). Once the maximum computing time defined by the user has been reached, the best solutions found by the GOM optimizer are presented for each airline in the UI. Each airline must rank the solutions (task P4), and a decision-support approach based on the Borda count method helps them (as explained in chapter 6). As soon as all airlines validate their rankings, a second round of the Borda count method enables to identify the group consensus on the solution to implement (task P5, described in chapter 6). Finally, the solution to implement is published to the outside world, and the long-term equity index is updated (task P6), as well as the linked inequity weights to use at next instance of the GOM optimizer (developed in chapter 7).

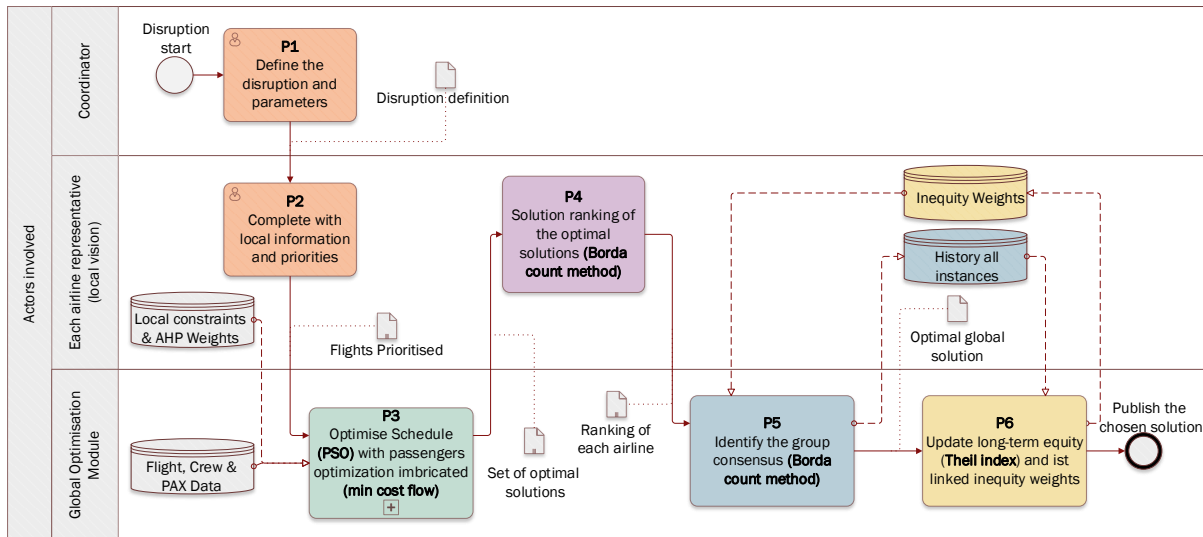

Figure 49: Final Business Process Model and Notation for the Global Optimization Prototype.

Experts were involved in the development of this work all the long, be it with the multi-criteria definition and assessment (chapter 5 corresponding to task P3 on Figure 49) but also on the different constraints to consider (in the definition presented chapter 4 and in the development in chapter 8, corresponding to task P3 on Figure 49) and the new concepts defined (such as the group consensus in chapters 6 and the long-term equity index and compensations in chapter 7, corresponding to the tasks P5 and P6 on Figure 49). Specific experts were also consulted for given subjects, such as the costs to use in the passenger optimization (chapter 9, that is a part of task P3 on Figure 49). The GOM user interface was also regularly presented to the experts to gather their feedbacks (from task P1 to P6 on Figure 49). SWISS and Lufthansa Munich experts were the most committed from the beginning to the end to answer all the questions and discuss about specific development parts.

### 10.1. Prototype Definition and Environment

The GOM prototype was developed locally and deployed on the SWISS research environment ORCAS eLab. It consists of four main elements:

- the user interface (UI), developed with angular components,
- the GOM SQL Data Base,
- the GOM Service coded in C#,
- and the GOM Optimizer coded in C#.

Figure 50 illustrates the architecture of the GOM prototype in the SWISS environment. The yellow boxes correspond to services already existing; the white ones correspond to operational systems and the blue ones correspond to the developed parts for the GOM.

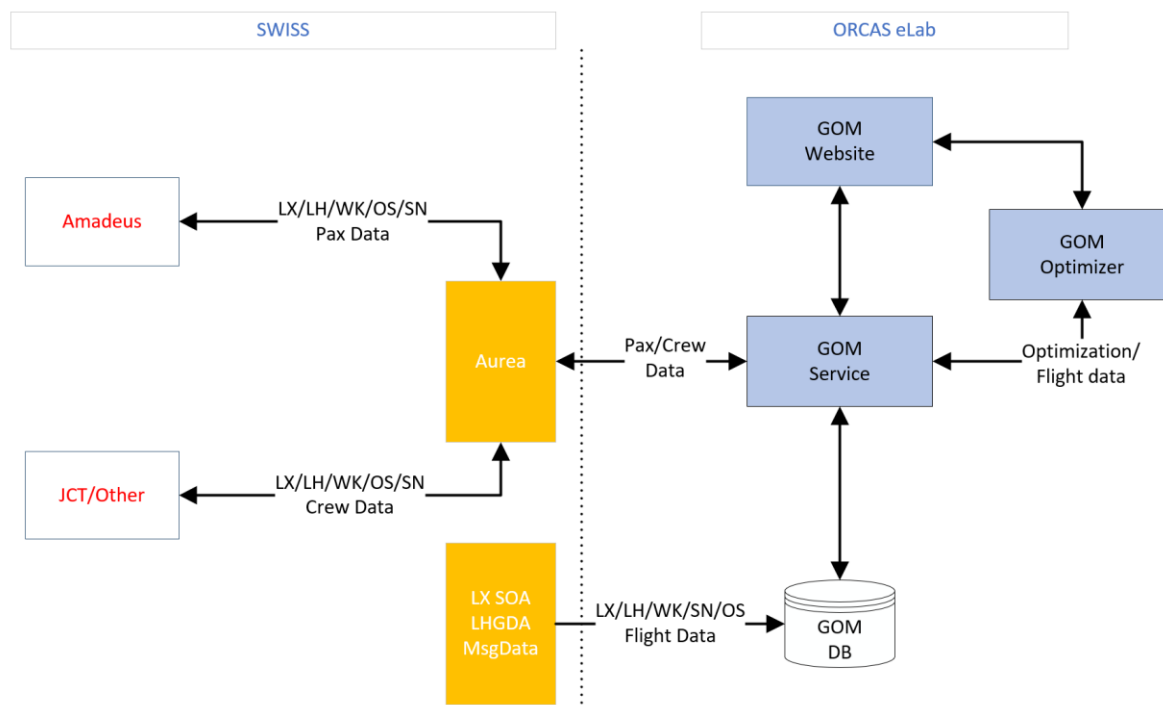

Figure 50: Global Optimization Current Architecture.

The GOM has been tested and demonstrated to Lufthansa Group operational users and managers on several occasions in summer and autumn 2023. For the demonstrations, the GOM ran locally on a CPU 11<sup>th</sup> Generation Intel Core TM i9, with 32GB RAM, processor 2.6 up to 5GHz and operating system windows. The feedbacks were positive and the shift of paradigm, enabling all airlines to optimize together during major disruptions was deemed interesting and welcomed by the attendees.

## 10.2. Use-Case and Data Collection

It is important to demonstrate the GOM capabilities on real operational data. This is the main possibility to quantify the real benefit of the system and proposed optimization code.

As explained in chapter 1, strikes happen regularly in Europe, mainly from Air Traffic Controllers, but also from ground handlers or security staffs from airports. In 2018, Airlines for Europe (A4E) reported 24 ATC strike days within the first six months of the year, causing 5'000 flight cancellations and thousands of delay (Airlines for Europe, 2018). In 2019, (Performance Review Commission, 2020) indicated a slight reduction of -13.5% in the amount



of ATC strike days in Europe. From 2020 to 2022, the traffic was heavily impacted by the Covid-19 crisis. From 2023 onward, French ATC strikes, Italy ground handling airports staffs, UK security staff strike, Spanish airline and airport strikes, as well as German airport security and ground handler staff strikes greatly hampered the European air traffic. In the first three months of 2023 only, 38 days of strikes happened (see Figure 51, based on EUROCONTROL CODA reports<sup>11</sup>). Strikes leading to mandatory cancellations are unfortunately a common bottleneck in airlines operations and is the first main use-case of the Global Optimization Module (GOM).

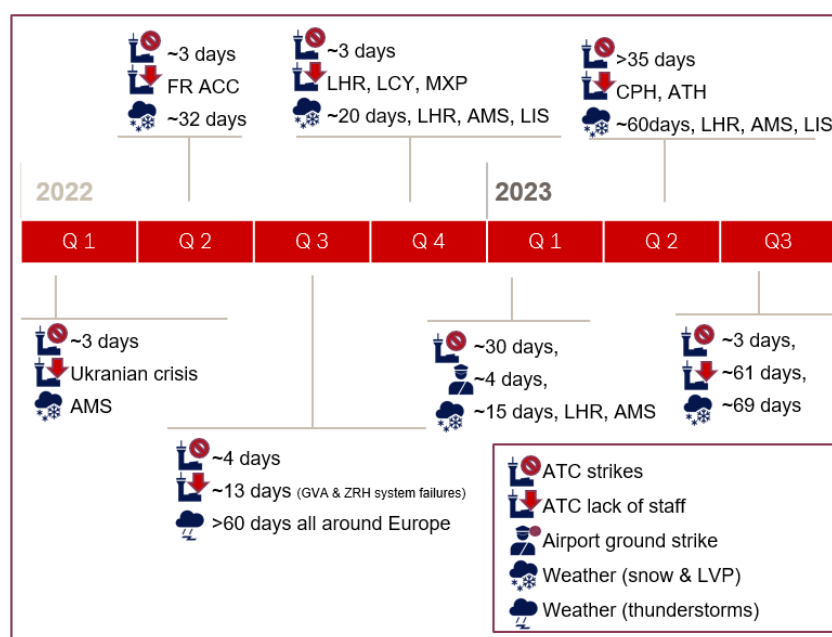

Source: EUROCONTROL CODA Reports 2022 and 2023, and analysis on all ATFM delays on LHG flights with regulations >1.000 minutes of delay total. data provided by CODA team.

Figure 51: Illustration of all the mandatory capacity reduction since 2022.

The GOM was first developed on a set of post-operations data collected from December 2019, as many French ATC strike days happened during this month. Formatting and cleaning the data was a mandatory but time-consuming part, especially for the group passenger data that were having an unclear format, structure, and quality. After developing and calibrating the algorithm on these data only (see section 8.2.3 and Appendix D), a quantification of the GOM solutions was necessary on more recent data to compare it with the decisions made by the operational managers from all Lufthansa Group airlines.

A major strike on May 1<sup>st</sup>, 2023, from the French Air Traffic Controllers imposed mandatory traffic reduction at Nantes (NTE), Nice (NCE) and Marseille (MRS) airports of 33 percent, as

<sup>11</sup> [Library \(Search\) | EUROCONTROL](#)

well as 25 percent in Paris Charles de Gaulle (CDG). We were successfully able to gather all passenger data (flying on any airline of the Lufthansa Group from/to CDG, MRS and Toulouse (TLS)), crew data (for LX only, to CDG and NCE) and flight data (for all airlines for the entire month of May) before the strike happened. Thus, the strike of May 1<sup>st</sup>, 2023, at CDG was the instance to test the GOM optimizer and quantify its benefits in comparison with the status quo independent decision of each airline.

42 flights operated by 5 airlines of the Lufthansa Group were planned in the disruption window, affecting 4,309 passengers (distributed in 2,281 reservations). From SWISS, data for 13 crews were retrieved. Concerning the aggregated flows of passengers by origin and destination, 134 flows were calculated, for which 616 alternative itineraries were retrieved through the multi-availability request from the Amadeus system.

Unfortunately, this request for alternative itineraries has some technical limitations: the field indicating the number of seats available on a given flight can only be 1 digit. This means that a flight seat availability is by default “capped” by a maximum of 9 seats, even if more seats are available. Moreover, not all alternative itineraries were retrievable, and only the ones corresponding to the first “page” of the Amadeus system were returned. Finally, the retrieval of the alternative itineraries data was for technical reasons delayed and retrieved only during the summer period. As the request can be used only for current and future operational days but not for days in the past, the alternative itineraries used for the quantification on May 1<sup>st</sup>, 2023, scenario in section 10.6.2 are the ones of August 15<sup>th</sup>, 2023. This is a bias to the real data used by the operational experts as they took the decision to cancel flights for the May 1<sup>st</sup>, 2023, strike.

Therefore, a comparison with the real full post-operations data is not possible without biasing the analysis, as not the same data for the alternative itineraries can be used. As a substitute, we proposed a “simulated reality”. As all the flights data were available in post-operations, the decisions of the operational experts to cancel or delay given flights were easily retrievable. Based on the real schedule published by the operational experts, the accurate passenger optimization (see chapter 9) was run with the limited alternative itineraries from our data set. We used the outputs of this optimization to create the so-called “simulated reality”. The solutions proposed by the GOM prototype can thus be quantified in comparison with this “simulated reality”. Even if quantifying the GOM prototype with this simulated reality is not ideal, no other opportunity took place, to extract all the necessary data before the strike

happened (several attempts were – unfortunately for the research outputs – aborted due to the strike cancellations on short notice). These data being business sensitive, the following sections will present only gathered results.

### 10.3. Preliminary Configurations – AHP Questionnaire

Before the first optimization runs, the main users must fill in some information in the “Admin” tab of the UI. Each airline is responsible for maintaining up to date this information. These are the flights at risk for the European 80/20 airport slot rule (see n°1 on Figure 52, definition in section 4.1.7 and constraints in section 4.4.1), the traffic waves at their hub (see n°2 on Figure 52, definition in section 4.1.4 and constraints in section 4.4.1) and their answers to the AHP questionnaire ( see n°3 on Figure 52 and more details in section 5.2).

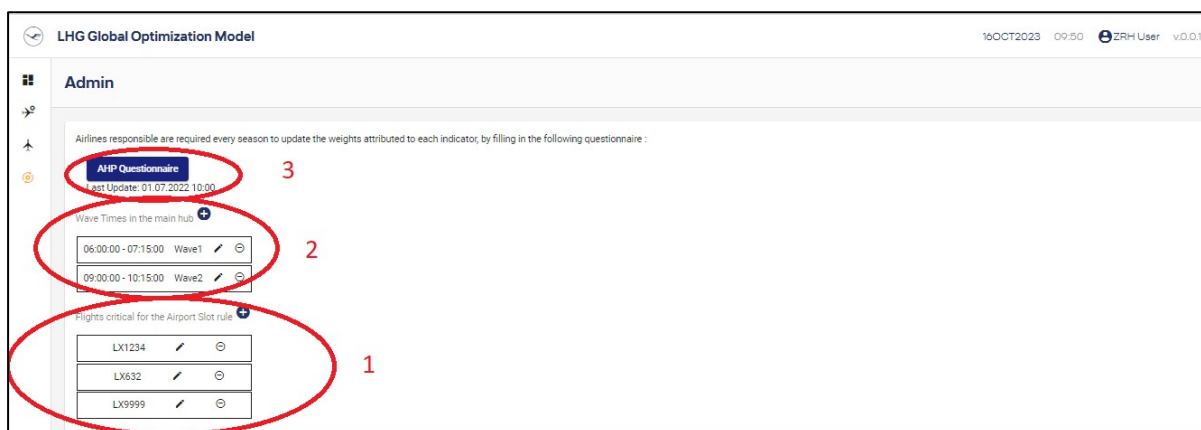

Figure 52: User Interface P0 – Administrative Tab

Moreover, the airlines should not only fill the AHP questionnaire for the group vision, but also the three additional AHP questionnaires with their own local priorities for the three operational scenarios as defined in section 7.2.1.

The part requiring the most inputs from operations experts were the definition of the indicators (see section 4.5) and the validation phase (see section 5.2.3). The AHP criteria tree was defined with the eight experts representing six airlines out of seven. Some of these experts answered the AHP pairwise comparison questionnaire later on, during the validation phase (reduction of experts' involvement due to the Covid-19 crisis).

One of the outcomes was the difficulty sometimes to reach a consistency ratio (CR) below 10% (see definition in section 5.2.2.2) especially for the categories with more than three criteria. For the passenger sub-group, this was relatively easy as the grouping of passenger categories are based on well-known and already hierarchical gathering (see Figure 12, p. 86). However, for

crew criteria, all criteria were different, conflicting one with each other, and it was time-consuming for one of the users to get first a good assessment of the priorities, and then reach a CR below 10%.

Some authors enabled a CR below 20% (Hamidah *et al.*, 2022; Ishizaka and Siraj, 2018; Misran *et al.*, 2020). However, the users agreed with the need for consistent answer, especially for the group vision questionnaires.

One interesting output was to observe the answers of the experts filling in the four AHP questionnaires. While the pairwise comparisons for the different passenger categories (see definition in section 4.1.5) were always filled-in the same in the four AHP questionnaire per airline, one could remark a difference in the pairwise comparisons for the crew categories as well as for the indicator categories (operational, crew and passengers). This highlights that the core business of each airline for the passengers does not change with the group vision or with different local operational situations, but that the priorities on the high-level do change.

#### 10.4. Task P1 – Define the Disruption

The coordinator – which role should rotate through the airlines each month – must first define the disruption characteristics before starting any group optimization. The UI is supporting the users to fill in dedicated fields, with some validity check to ease the process (see n°1 on Figure 53). All airlines with flights planned in the optimization window to fly from or to the disrupted airport are automatically displayed in a table. If necessary, the user can uncheck one or several airlines if these ones should not be included into the group optimization (see n°2 on Figure 53). Once all parameters are set, the user hits the “Start Coordination” button to notify all involved airlines that a group optimization requiring their inputs has started.

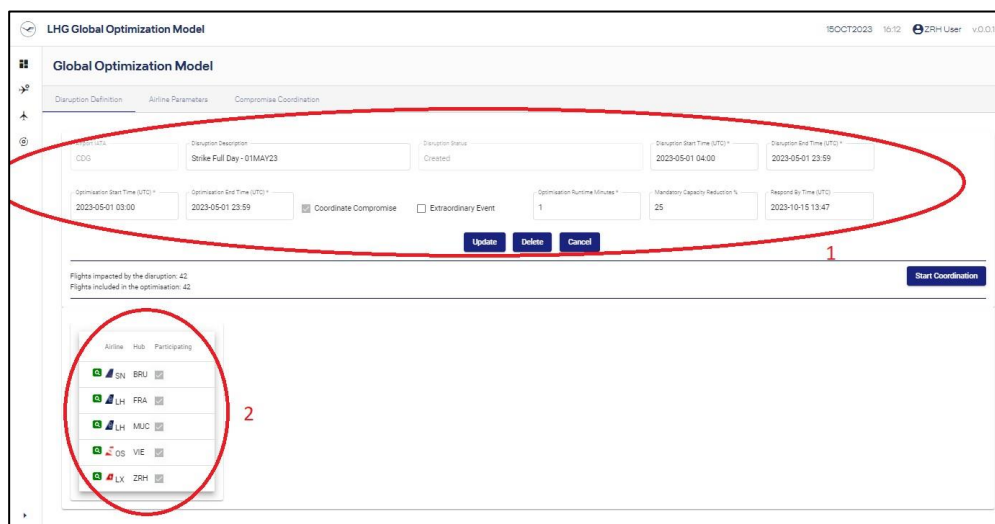

*Figure 53: User Interface P1 - Define Disruption.*

### **10.5. Task P2 – Airlines Priorities**

The airlines involved in the group optimization can input their priorities through the UI. The airlines can allocate tokens on given flights, to indicate their wish for neither cancellation nor delay (see n°1 on Figure 54). While this is no hard constraints from the optimizer, this is influencing the group macro-indicator through the indicator “unrespected tokens” calculation (see definition in section 4.5.4.2). This is influencing mainly the optimizer (task P3 on Figure 48) and the update of the long-term equity index (task P6 on Figure 48). The UI for tasks P4 and P5 for each airline is also displaying the “unrespected tokens” indicator.

The airlines can also select whether a traffic wave at their hub airport is considered as peak waves or not (see n°2 on Figure 54). A traffic wave selected as peak time to block from the user will be a hard constraint for the optimizer (in task P3 on Figure 48) not to delay any flight into the peak wave (see section 4.4.1).

The airline can also select the operational scenario corresponding the best to their current operations (nominal, crew constraints or hub constraints, see n°3 on Figure 54). This is useful for modelling the airline’s sensitivity in the long-term inequity calculations, as explained in section 7.2.1 (task P6 on Figure 48).

Last but not least, the airlines can always decide not to participate (sovereignty of each airline to join or not a group optimization, see n°4 on Figure 54).

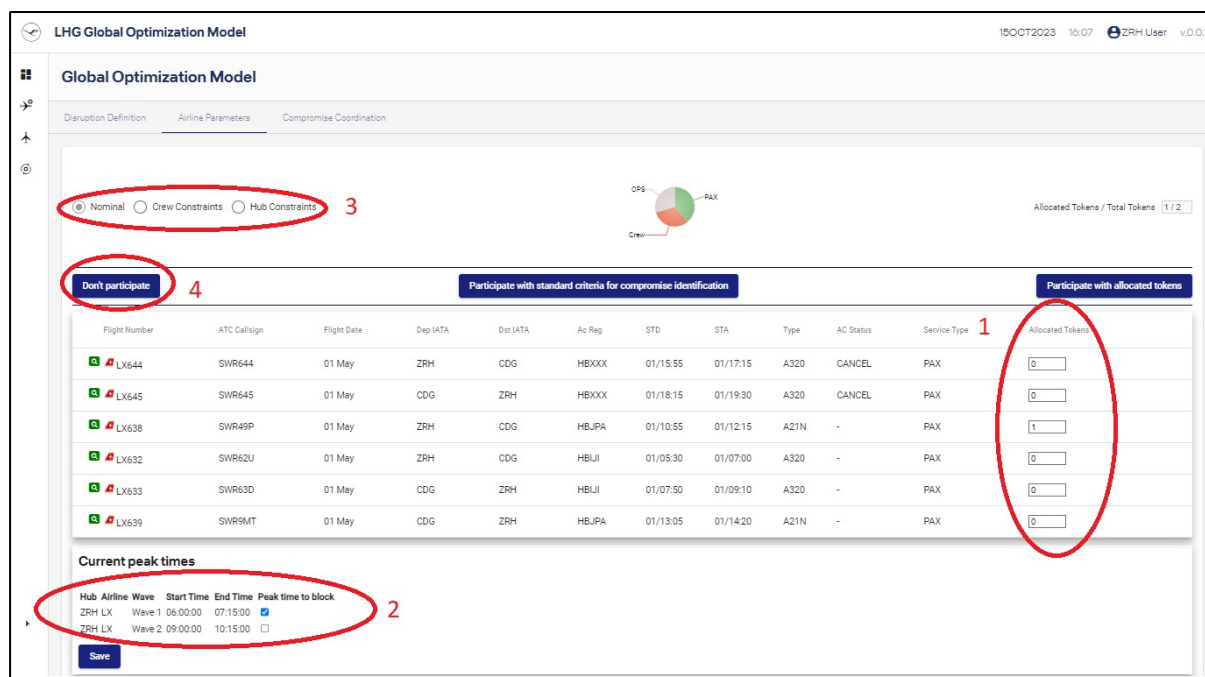

Figure 54: User Interface P2 - Airlines Priorities.

Once all airlines filled in their priorities, or that the defined “response by” time by the coordinator has passed, the coordinator can start the optimization.

## 10.6. Task P3 – Core Optimization

### 10.6.1. Industrial Use-Case size

Chapter 8 presented the schedule optimization based on the PSO. The approach described was implemented in the GOM prototype (section 8.2), with the parameters defined through the PSO calibration. The particles have 42 dimensions, as 42 flights were to optimize, and the velocity matrixes’ size were 65 x 42, as the maximum delay was set on 300 minutes. In average, 797 passengers were booked on the flights cancelled or delayed and were subject to the passenger optimization. Thanks to the gathering of passengers through flows, this enabled small size graphs to solve, with in average 250 arcs for 100 nodes. It should however here be reminded, that not all existing alternatives itineraries were retrievable, and that on a full data set, the graph size should be more important.

### 10.6.2. Results

As described in section 10.2, the GOM was tested on the data sample from May 1<sup>st</sup>, 2023, as a major strike took place. 100 replications of the GOM were launched to observe the behavior of the system and quantify the solutions proposed. A “simulated reality”, corresponding to the expert decision on the cancellations and delays independently from each other (see explanations in section 10.2) enables to compare the results and discuss them. As seen in Table

29, out of the solutions proposed by the GOM optimizer, 100% outperform the “simulated reality” in regards with the group macro-indicator. It is worth deepening in the different indicators categories.

Concerning the operational indicators, all tokens allocated by the airlines (see section 4.1.7 and section 10.5) were respected, and the delays proposed by the GOM optimizer were not affecting the consecutive operations. From the crew indicators perspective, only crew data from SWISS were available, and thus, only a partial conclusion can be drawn: all crew indicators were minimized (i.e., equal to 0) in the solutions found by the GOM optimizer. The indicators for the crew have been removed from the table for more readability, as no solution were negatively impacting a crew.

Some differences occur within the passenger indicators, which also are the prominent ones to check the quality of the GOM optimizer solutions in comparison with the “simulated reality”. It can be observed that the GOM optimizer is finding better solutions for the passengers in 90% of the instances. By investigating more in details, in these 90% of the replications, the GOM optimizer finds rebooking solutions for in average 122 additional passengers in comparison of the “simulated reality”. In the last 10% of replications, the GOM optimizer underperform by having in average 51 passengers less with solutions than in the simulated reality. The 90% of replications presenting less economy class passengers with no solutions (column “Pax No Sol Y-CL” in Table 29) can be explained by the fact that the schedules proposed by the GOM optimizer are mostly adequate to enable smart rerouting of the passengers flows, as well as finds for around 10 passengers in average costly solutions, instead of no solutions.

Table 29: Overview of the GOM results on 100 instances.

Tested over 100 instances										
GroupPerf	PAX with solution	Pax Costly P1	Pax No Solution P2	Pax Costly C-Cl P1 <sub>C2</sub>	Pax No Sol C-Cl P2 <sub>C2</sub>	Pax Costly Y-Cl P1 <sub>C4</sub>	Pax No Sol Y-Cl P2 <sub>C4</sub>	Ops Impact O1	Unrespected Tokens O2	
GOM outperforming the Simulated Reality	100%	90%	9%	90%	99%	100%	9%	90%	100%	100%
GOM avg	0.00138	3'915.80	28	393	0	1	28	393	0	0
Simulated reality	0.017199	3'811.00	18	498	1	5	17	493	0.12	0
Total Number of Passengers/flights		4'309	4'309	4'309	42	42	4'309	4'309	4'309	4'309
							average passengers saved			104.80
							average passengers saved for GOM better solutions			122.17
							average passengers saved for GOM worse solutions			-51.50
							average similitude to schedule decided by the experts			13%
							average similitude to the best solution found by GOM			61%
							% of GOM solutions delaying flights			10%
							average delay per flight delayed by the GOM (in min)			36
							average number of delayed flights			1

One can remark that the business class passengers disrupted (referred in Table 29 as “C-CI”) are all having better solutions through the GOM optimizer.

Checking in details each replication, only two out of 100 are downgrading one passenger to economy. The simulated reality finds no solution for 4 business class passengers, while the GOM finds solutions presenting in 80% of the cases no business class with no solutions, and 20% of the cases 2 or 4 business class passengers with no solutions. While the ideal case would be that the GOM always finds solutions for all business passengers, it still finds better solutions than the simulated reality, increasing the number of satisfied passengers. Some further refinement might offer even better solutions, starting with loading the full set of alternatives itineraries into the database (see section 10.2).

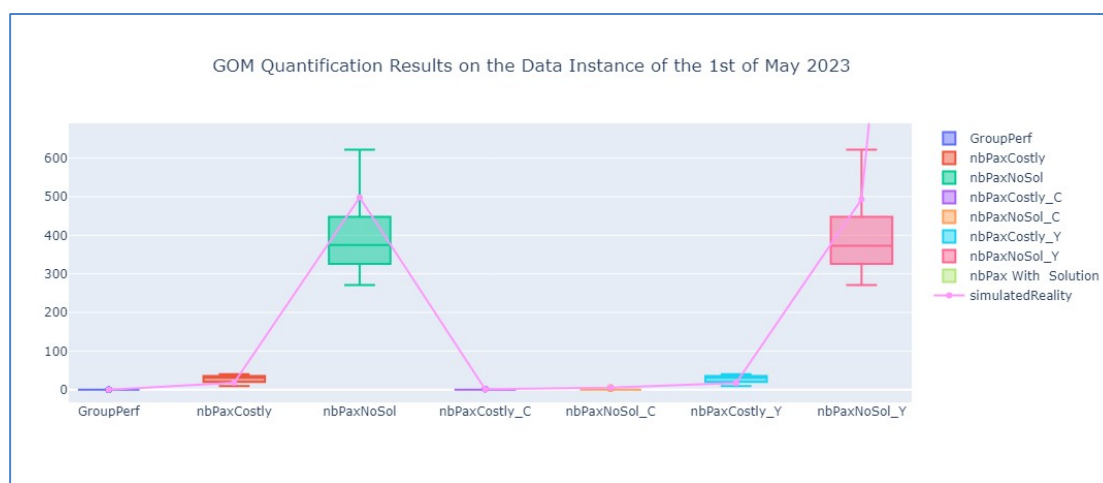

Figure 55: Results of the GOM on 100 test-replications for the strike scenario.

Figure 55 illustrates the results of the simulated reality (pink line) in comparison with the results proposed by the GOM on the 100 replications for the passengers. This shows clearly that the solutions proposed by the GOM outperform the simulated reality by reducing the number of economy class passengers with no solutions (indicator “nbPaxNoSol\_Y” on Figure 55, corresponding to the indicator  $P2_{C4}$  defined in section 4.5.2.2). On top of finding suitable satisfying solutions for in average 105 additional passengers, it also allows more economy class passengers to have upgrades or delay over the EUC261 threshold, enabling more passengers to reach their destination on the same day as initially planned (passengers with costly solutions for the airline corresponding to the indicator “nbPaxCostly\_Y” on Figure 55, corresponding to the indicator  $P1_{C4}$  defined in section 4.5.2.1).

Table 29 also shows two interesting aspects regarding the similitude of the solutions proposed by the GOM. In average, the 100 replications of the GOM present a similitude of 13% with the



decision taken by the airlines independently, and 61% with the best solution found over these 100 replications. It means that in average only one or two flights in the proposed GOM solutions are common with the ones cancelled independently. On top of that, only 10% of the replications propose delayed flights, those replications delayed only one flight of on average 36 minutes.

Under the knowledge that not all data were accessible, the experts found the solutions valuable and expect significant potential from the system, as soon as linked with actual real-time data. Of particular interest to them is the fact that the GOM prototype is the first of its kind to propose a group optimization and coordination. The number of saved passengers is equivalent to an additional A220-100 (short-haul aircraft) operated flight full of passengers.

#### **10.7. Task P4 – Airline’s Ranking Decision-Support**

Once the GOM optimizer reaches the time limits provided by the user, the 5 best solutions are returned to the UI (less if the optimizer converged). The number 5 was chosen with the experts to provide enough choice in the solutions set that did not converge, while limiting the number of solutions to rank (the maximum number corresponding to the number of particle if none of them started to converge). Each airline user can go on the “Compromise Coordination” tab and see the details of each solution on its own operations (see Figure 56). With a mouse over the indicator, the user can see some more details such as its flights cancelled and delayed, the number of passengers with costly solution or with no solution, per booking class, which crew are impacted, etc. If no passengers or no crew are impacted, the indicator value is a “-“. On the example showed on Figure 56, the user is presented with two solutions impacting the same flights, but with a different result for its passengers. This can be explained by the other cancelled and delayed flights of the other airlines, leading to more or less possible smart rerouting of the passenger flows.

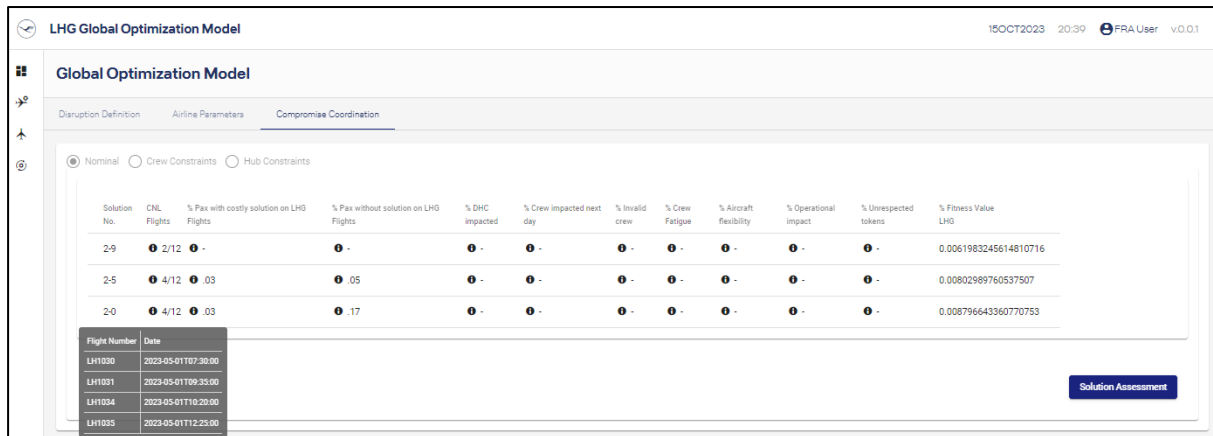

Figure 56: User Interface P4 - Airlines Ranking Decision-Support.

The user can then switch to the decision-support based on the Borda count method. Chapter 6 developed an adaptation of the Borda count method, first considering each indicator as a voter. To consider the user sensitivity and better model the ranking through its operational priorities, the user is asked to adapt if needed the interactive UI presented in Figure 57. For each indicator, default values are entered for the indifference threshold and the acceptable interval of performance. The user can change it as wished and submit these to the Borda based method in the back end. This returns a ranking that the user can validate or adapt before validation. This process takes less than 0.1s.

On Figure 58, one can remark that the solution 2-9 with 0% of passengers without solutions, and the solution 2-5 with 5% are ranked both 1<sup>st</sup> while solution 2-0 with 17% of passengers without solutions is ranked 2<sup>nd</sup>. This is due to the acceptable interval of performance for this indicator being set to [0;0.05] by the user on Figure 57. The two solutions are thus considered both equivalent for this indicator, which influence the airline's ranking. If ever the user regret to have given such an acceptable interval, it can manually adjust the ranking to rank solution 2-5 as 2<sup>nd</sup>.

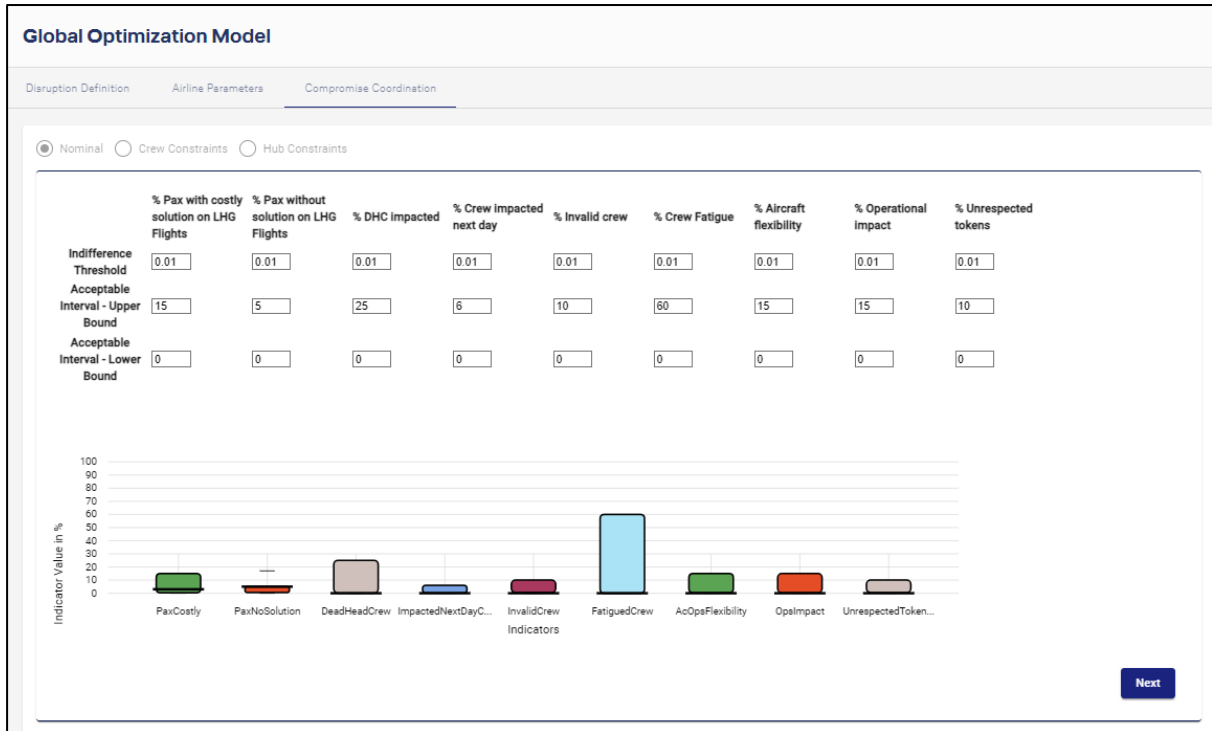

Figure 57: User Interface P4 – Airlines Ranking Decision-Support, User Sensitivity Inputs.



Figure 58: User Interface P4 – Airlines Ranking Decision-Support, Airline Ranking.

In case the airlines do not have the possibility or the time to validate their ranking based on task P4 by the end of the response time, an automatic process must take place. As the airline selected in the task P2 (section 10.5) in which operational scenario its operations belong, the AHP weights of the corresponding questionnaire are used. Each solution gets then a macro-indicator with the indicators calculated for the flights and passengers of this airline only and weighted through the corresponding local vision AHP weights. The solutions are then ranked by increasing value of the macro-indicator, and this is used as a ranking for the task P5.

### 10.8. Task P5 – Group Consensus

Once all airlines have submitted their ranking, it triggers the last back-end task based again on Borda count method, this time considering each airline as a voter. This task takes less than 0.1s. It presents the results of the consensus in the UI to all users, and the coordinator should click on “Implement” to send out to the operational systems all the cancellations, delays and rebooking to publish (see Figure 59). For the sake of transparency, all airlines can see the impact of the consensus solution on all airlines participating to the group.

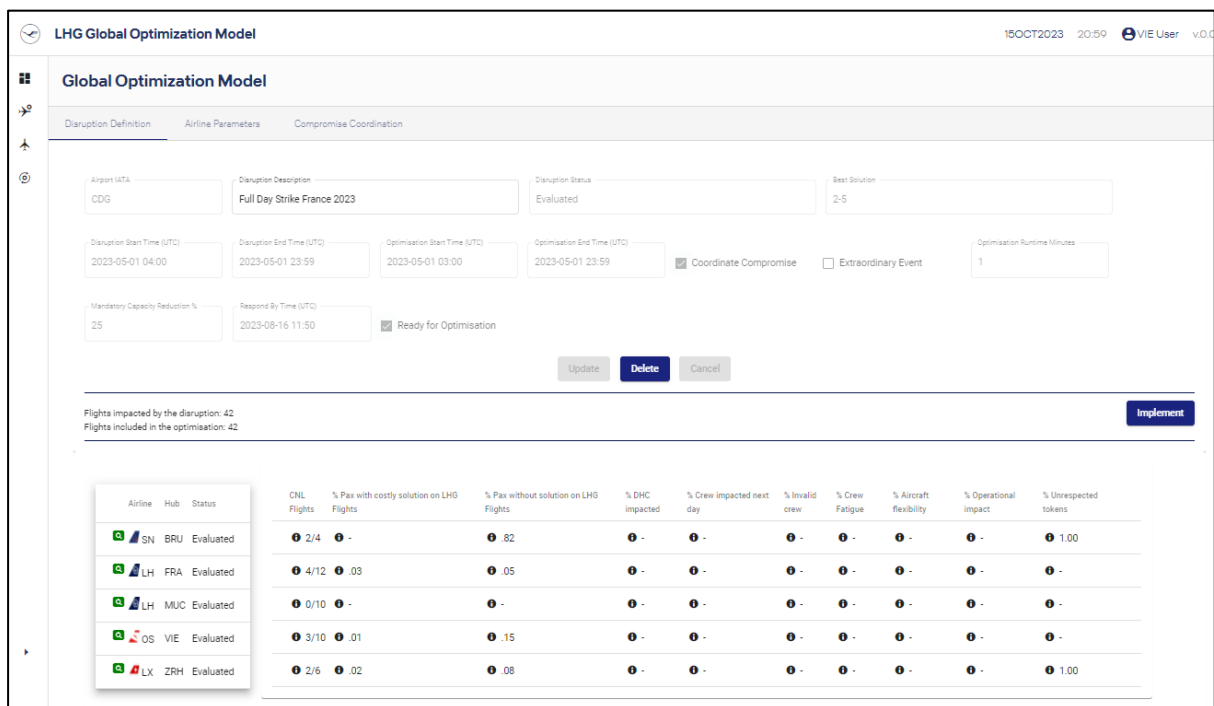

Figure 59: User Interface P4 – Group Consensus.

### 10.1. Task P6 –Long-Term Inequity Related Inequity Weights Update

Once the consensus solution is implemented, the long-term equity index is updated with the impact on each airline. This triggers the update for the inequity weights (see section 7.2) that will be used for the next instance of the GOM optimizer.

The only concept that is not integrated in the GOM prototype in C# is the long-term inequity calculation, coded in python. This part should be integrated into the GOM prototype once the implementation of the system in live operations would be officially decided. Indeed, calculations of long-term equity and deriving inequity weights from it necessitate recording the history of real instances being implemented in live operations.

For the sake of illustrating the quantification of the inequity and its translation into inequity weights, Table 30 provides the calculations steps to update the global long-term Theil index on this first instance (no history in this example). Each airline selected in task P2 (see section 10.5) different operational scenario corresponding to the operational situation at their main hub. According to the scenario selected, the local performance per airline is assessed with the weights provided by the AHP questionnaire corresponding to the selected scenario of the given airline. The  $temp_i$  can be calculated (see section 7.2.2, Eq. 103 p. 122) and the sum on all airlines provides the Theil Index. Then, the inequity weights can be derived from each  $temp_i$  thanks to the Boltzmann SoftMax operator (see section 7.2.3.1, Eq. 104 p.127 ).

Table 30: Long-term inequity Theil index and its derived inequity weights calculation

Airline	Selected Scenario	Local Performance	$temp_i$	Derived Inequity Weights
SN	HUB	0.2118	-0.1440	0.9578
LH FRA	NOM	0.0333	0.0343	0.0111
LH MUC	NOM	0.0000	0.0718	0.0043
OS	CREW	0.0333	0.0343	0.0111
LX	NOM	0.0461	0.0203	0.0157

Theil Index:	0.0167
--------------	--------

One can remark that the most disfavored airline, in this example SN, is getting for the next instance an inequity weight which is very high in comparison to the other airlines. On the contrary, LH MUC is not impacted at all by the group optimization, and thus gets the smallest inequity weight for the next instance, as it was much more advantaged than the other airlines.

## 10.2. Conclusion

The Global Optimization Module is a prototype with the back-end coded in C# and the front-end coded with Angular components. It integrates almost all features described in this thesis, except the long-term equity index and linked inequity compensation mechanisms. Indeed, those require real instances of the GOM implementing in real life solutions. Those are coded in Python in a separate environment and is running on fictive data.

While the GOM prototype was developed locally, it was regularly deployed on the SWISS research platform. The GOM prototype was developed on real data from 2019 strikes. It was then tested against real data from the French strike on May 1<sup>st</sup>, 2023, and the real decision of

cancellations and delays of each airline independently. 100 replications were achieved, to enable confident analysis.

The tests were conducted on a unique strike scenario, as it is complicated to gather all data before any strike take place. Only limited and not sufficiently good (quality-wise) data were considered for the crews. While the GOM prototype always proposed solutions not hampering any crew indicators, those should help better guide the particles towards operational trade-offs defining good solutions. Thus, it would be very interesting to test the GOM on scenarios with complete data set for the crews. Furthermore, limited alternatives itineraries were loaded in the GOM system, as the request from Amadeus is by default providing only a small set of the existing ones, with seat availabilities capped to 9 seats available maximum, despite more seats free in the flight (limitation of the Amadeus multi-availability request).

While an exact comparison was not possible due to lack of data and quality of the data, a comparison with the so-called “simulated reality” enables to compare as a lower bound of performances. Indeed, the GOM prototype is proposing new schedules for the entire group, optimizing the passengers flows on limited alternative itineraries data set.

In a summary over the 100 replications done, we can state that the GOM prototype validation on real operational data is showing very promising results. It always offers solutions outperforming the “simulated reality” in matter of the group macro-indicator (see chapter 5). It offers as well in most of the cases (90%) group solutions outperforming the one chosen by the operational experts independently, with in average 122 additional passengers with suitable solutions on the same day. This is thanks to its ability to compute on a group level the best combinations of cancellations and delays to offer the best operationally viable solutions.

By optimizing on a full and realistic data set, one can expect the GOM optimizer to outperform even more the independent chosen solutions per airlines, as from its computing power and smart optimization features.

The processes as described in this part takes around 15 minutes: around 2 minutes for the coordinator to fill-in the disruption description, 5 minutes for the airlines to fill-in their priorities, 2 minutes for the GOM optimizer to find interesting solutions, 5 minutes for the airlines to validate their local ranking and 1 minute to verify the consensus and implement it.

With the current decision process, each airline proceeds differently to choose the flights to delay and cancel. The experts reported an average decision time of 15 minutes and up to 2 hours depending on the airlines and the disruption.

The GOM prototype would thus enable to reduce the workload of the airlines participating in the group optimization, on top of finding better solutions for the group.

However, it must be noted that once the group solution is published, some local conflicts might have to be resolved by the airlines, as some constraints were relaxed and the full granularity of data is not considered (see chapters 3 and 4).

This provides some perspectives. The GOM prototype should be connected in the future to good quality of live data. This would enable more realistic and detailed analysis of the GOM prototype outputs, open the door for many refinements in the data handling, constraints, and indicators refinement, as well as a true quantification of the GOM prototype benefits.

---

# Conclusions and Perspectives

---

## 11. Conclusion

This thesis started from a simple hypothesis: “Together, we are stronger”. Nowadays, when a disruption occurs, each airline tries to find out the best schedule for its flights and aircraft. The goal is to accommodate at best its own passengers and crews as well as reduce as much as possible the disruption effect on the next hours or days of operations. This thesis aims at proposing and validating a new paradigm shift:

- whether a group optimization is feasible or not,
- and if feasible, does it bring benefits not only for the group as a whole, but also to each individual airline on the long-term?

This thesis is funded by Swiss International Air Lines, airline member of the Lufthansa Group.

### 11.1. Thesis Summary

Chapter 1 aims at providing a general background for the current airline operations. It explains on a high level the different processes and decisions needed to plan and operate a flight (strategic and tactic phases). The current framework of operational disruption is introduced, with its different challenges. Finally, a statement on the coordination in a group of airlines brings to light the room for improvement, especially during disruptions.

Chapter 2 presents a review of literature on the airline operations problem. The operations research field produced numerous scientific advances to help one airline optimizing its operations during a disruption. Some tackled several hubs optimization, but always under the control of a unique Operations Control Center. No multi-airline operations optimization was proposed – as from the author’s current knowledge –, with different airlines steered by different Operations Control Centers belonging to a same group.



Thus, chapter 3 establishes the foundation and structure for this thesis: develop an approach to optimize multi-airline operations under disruption, enabling multi-stakeholder decision-making, with conflicting local objectives but the willingness to work together for the group optimum. Several research questions are raised, highlighting the need for research.

Chapter 4 presents the mathematical model, detailing the data that can be considered for a group optimization, as well as the constraints to be respected for providing feasible solutions. It also defines mathematically the indicators to consider for a group assessment of a solution.

Chapter 5 develops those indicators in collaboration with operational experts thanks to the Analytic Hierarchy Process. This methodology enables to structure the indicators in a hierarchical tree and gather in a consistent manner the airlines' experts' opinions through a questionnaire, resulting in a consolidated group weight for each indicator. This leads to the macro-indicator used in the core optimization to assess each new solution found.

Still on the topic of a group decision-making process, chapter 6 proposes a concept to help the airlines reaching a consensus. Indeed, the core optimization could suggest different optimal solutions for the group if it did not completely converge (limited computing time). An adaptation of the Borda count method considering the airline sensitivity thanks to indifference thresholds and acceptable interval of performance per indicator is defined to support each airline ranking the solutions as from the impact on their own operations. Once all airlines ranked the solutions, a second round of the Borda count method enables to identify the solution being the group consensus. It is important to have the airlines actively participating to the group consensus process, to increase the user trust and acceptance into the proposed system.

Chapter 7 addresses a significant requirement for a group optimization: equity. As considering a strict equity in each optimization instance would reduce the search space and hamper the optimizer to find optimal solutions for the group, a brand-new concept for long-term equity is proposed. An adaptation of the Theil index is proposed, based on the airlines sensitivity towards the solution implemented. The outputs of this long-term equity index are derived in inequity weights through the Boltzmann SoftMax indicator, to influence the second round of the Borda count method appointing the group consensus solution. This enables a fair and transparent inequity compensation mechanism very well suited for slightly imbalanced situations.

Chapter 8 tackles the group schedule optimization method. A discrete Particle Swarm Optimization (PSO) method is proposed based on (Izakian *et al.*, 2010), and further adapted

for our specific use-case. This is producing very interesting solutions and computing efficiently optimal planning for the group. This is the first application of the PSO on the airline aircraft recovery problem, as from the author's best knowledge.

Chapter 9 presents two methods for the passenger flow optimization: an upper bound estimation of the disrupted passenger costs and an accurate optimization modeled as a minimum cost maximum flows problem. After a great work of refinement for both methods and code optimization, both methods presented similar computing time with a different quality of passenger reassignment. Thus, each new schedule proposed by the PSO is optimized accurately for the passenger flows, and the results are assessed through the group macro-indicator developed in chapter 5.

Finally, chapter 10 demonstrates the developed prototype called the Global Optimization Module, integrating all modules described above except the one for the long-term equity (which necessitates an implementation in real life operations). It is tested against real data from a strike in May 2023 (100 test-replications). The results are very encouraging: 100% of the replications present a better group macro-indicator than the real operational decision taken independently by each airline, and 90% of the solutions find more rebooking alternatives for the passengers of the group flights impacted by the disruption.

### 11.2. Thesis Contribution to the Research Questions

Six research questions were raised in chapter 3, for which this thesis contributed.

*Research Question 1: propose a definition of the trade-off in all the data and constraints that a group optimization can consider, while keeping the computation time within the given limits.*

*Research Question 2: Define an optimization methodology able to propose group optimal solutions.*

A mathematical model was presented in chapter 4, highlighting the granularity of data enabled for a group optimization, as well as the constraints to respect for providing feasible solutions. Based on this model, chapter 8 proposed an adaptation of the Particle Swarm Optimization (PSO) method for our group schedule optimization problem. Imbricated into the PSO, the passenger optimization method (chapter 9), modelled as a minimum costs maximum flows

problem, searches for optimal rebooking of disrupted passenger on each schedule proposed by the PSO at each iteration.

Each solution found by this core optimization must be evaluated with a group vision. This is the third contribution of this thesis:

**Research Question 3:** *propose a method for a group decision-making and definitions of the indicators, respecting the airlines specificities and main business objectives to enable a group optimization.*

The multi-stakeholder decision-making approach relies on the Analytic Hierarchy Process (AHP), involving actively operational experts in the process. A multi-stakeholder AHP was developed and successfully tested in chapter 5.

**Research Questions 4 & 5:** *propose a process enabling:*

- *each airline to express its assessment of the proposed solutions,*
- *a group consensus to be reached on the solution to implement,*

*while guaranteeing the trust and acceptance of the group optimization model.*

A method based on a two-rounds Borda count method was developed and tested in chapter 6. A first Borda round is applied first for each airline independently. Once all airlines validated their ranking, a second Borda round takes place, consolidating the rankings and eliciting the solution to implement as a group consensus.

**Research Question 6:** *propose a definition of the long-term global equity among all airlines participating to the group optimization and demonstrate that this equity can be reached under given assumptions through dedicated mechanism.*

A long-term global equity index was developed and successfully tested in chapter 7. Developing further the Theil index (poverty equity index), it proposes a multi-indicator and multi-instance calculation of the equity and derives inequity weights to influence the second Borda round. The tests demonstrated a real ability of the inequity weights to rebalance through several instances the long-term equity.

This thesis proposed a first approach to a multi-airline operations optimization under disruption, answering all research questions identified in chapter 3. However, it also raised numerous perspectives for future research.

### 11.3. Thesis Perspectives

Many perspectives arise from this work, either to improve the methodologies and developments proposed, to extend to further complexity, or to boost research in given areas.

From a technical viewpoint, short-term adaptations of the method could enhance the core optimizer. While the Particle Swarm Optimization shows satisfying results and efficient computation on disruption of an outstation airport (not being the hub of any airline), some more improvements could be proposed to ensure an efficient exploration of the search space for bigger instances sizes. For example, though advanced neighborhoods strategies (either dynamic or in sub-swarms) or tailored rules to transform the velocity into a position.

Besides the improvement of the schedule optimizer, also the passenger optimization method could be improved. As pointed out in chapter 9, there is room for improvement, both on the modelization of the costs (especially the delay) and on the consideration of uncertainties (e.g., of passengers accepting the rebooking or searching for their own solutions, freeing up some additional seats for other passengers, as proposed by (Hu *et al.*, 2021)).

Moreover, the group macro-indicator analyzing the solutions proposed by the optimizer could be extended to a Fuzzy Analytic Hierarchy Process, considering the uncertainties in the data. Indeed, a group optimization does not have the full granularity of data nor considers all local constraints and specificities. For example, the uncertainties of crews reporting fatigue might be for some airlines remarkably interesting and bring a true added value to the robustness of the solutions proposed.

Finally, on the group consensus process, the method had to be easily understandable and very clear to build the users trust and acceptance of this new paradigm shift. Once the users' confidence in the group optimization and consensus process will be reached, it will not necessitate to get the experts actively involved. One could propose more sophisticated methods such as TOPSIS to provide a ranking per airline followed by a Borda round for the group consensus identification, as it did prove quite accurate in its behavior.

Not only the methodologies can be addressed with perspectives, but also the scope of the optimization problem. Indeed, this thesis was the first to address an airlines group optimization.

Thus, it was developed and tested on reasonable-scale problems such as a disruption occurring in a European airport, being no hub of the airlines' group. However, many disruptions occur in the main hubs (such as the "Bise" or snow falls in Zurich, restricting drastically the airport capacity, etc). As from the optimization methodology was defined and coded, an extension to any hub airport capacity reduction use-case would require only some small adjustments in the code but no methodology changes. It could also be adaptable to tackle disruptions linked to airspace overflight restrictions (without rerouting options).

The optimization variables could be extended to the seat capacity of the aircraft, either by moving the curtain separating the business passengers from the economy passengers, leading to adapted seat availability, or by swapping aircraft tail to allow the assignment of bigger aircraft on critical flights. With the growing social and political pressure, it could also be interesting to consider additional indicators about the environmental impact of the solutions such as a smart assignment aircraft to flights according to their fuel consumption efficiency (which is getting closer to a tail assignment problem with additional operational constraint and complexity due to the dynamicity of the operations) or the possibility to propose some velocity changes (accelerate the flight or fly on the economic cost-index). It might be however questionable whether a group optimization should really get so much in details into the aircraft assignment problem and if this should not remain in the airline's sovereignty.

The alternative itineraries for the passengers could also be extended to intermodal transportation modes. For example, considering trains (called "flight-train", already existing between Swiss cities or major hubs) with adapted costs and capacities, could be a leverage for better passenger solutions.

Finally, the long-term inequity methodology and its related inequity compensation mechanisms are demonstrated very efficient in slightly imbalanced situations. It would be interesting to extend the concept to very imbalanced situations (such as very different core business of airlines optimizing together) and try to find out whether new compensation mechanisms could be able to balance the inequity.

On the longer term, some prospects could be very interesting for further research work. It could for example investigate the operational and financial benefits of the group to validate if some tighter collaboration between the airlines would make sense. One scenario could be that an airline is not limited to operate flights from and to its hub, but to any hub of the Lufthansa Group airline with the constraint of being at its home base before the curfew time (e.g., SWISS

aircraft with a SWISS crew operating the following flight sequence: Zurich – Charles de Gaulle – Frankfurt – Oslo – Vienna – Zurich). Another scenario could be that a SWISS aircraft could be operated by an Austrian cockpit crew and a Lufthansa CityLine cabin crew, which would bring interesting optimization problems. This however goes far beyond the real feasible collaboration of today operations and could only be a feasibility study and quantification of the added value of the concept.

A last conceptual perspective, to which the author is firmly convinced about its adequacy, would be to adapt the new paradigm shift of the long-term multi-criteria equity definition and compensation mechanisms within the Air Traffic Management (ATM) current challenges. As explained in chapter 1, the European ATM is reaching its capacity limits, and the flexibility of the airlines would be tremendously increased in the delay management if Target Time of Arrival, extended Slot Swapping or other technics for better allocation of delay according to the airlines' priorities could accept to replace the strict equity objective by a more flexible long-term equity definition. We strongly hope that this work will make its way within the ATM practices and help the airlines – and *in fine* the passengers – to have a better on-board experience in the European sky.

# APPENDICES

## A.Mathematical Notation Table

Mathematical notation	Definition
$ACType$	Set of aircraft types
$Aircraft$	Set of aircraft belonging to the fleet of the considered airlines group
$AirlinesGroup$	Set of airlines belonging to the group considered, for which an element is noted $i$
$Airport$	Set of officially recognized airport by IATA and ICAO
$A_{Opti, i}^m$	Set of tails of aircraft type $m$ belonging to the airline $i$ available for the optimization
$A_{Opti, i}$	Set of aircraft available for the optimization, belonging to airline's fleet $i$
$A_{Opti}$	Set of aircraft operating the schedule and available for the optimization
$A_{Opti}^m$	Subset of aircraft of type $m$ available for the optimization, irrespective of the airline belonging it
$Aff_{Ini}^{Slot}$	Initially planned departure slot of the flight
$Aff_{Rel}^{Slot}$	Function providing the new slot affected for the flight (0 being a cancellation)
$Aff_{Ini}^{AC}$	Initially planned aircraft to operate the flight
$Aff_{Ini}^{Crew}$	Crew operating the flight
$Aff_{Ini}^{Pax}$	Function providing the information about the itinerary initially booked for a reservation
$Aff_{Rel}^{Pax}$	Function providing the new itinerary affected to a reservation in the solution
$Arr_{Ini}$	Function providing the arrival time of a flight
$Arr_{Rel}$	Function providing the arrival time of a flight $k_{fp}$ according to the departure slot assigned in the new planning
$Arr_{Airport}$	Function providing the airport of arrival of a flight
$Arr_{TimeI ti}$	Function providing the arrival time of the last flight of the itinerary at the planned destination

Appendix A - Mathematical Notation Table

<i>BlockTime</i>	Function providing the sum of the three precedent times
<i>CapaFlight</i>	Function providing the seat capacity of a flight and a specific booking class
<i>CapaItinerary</i>	Function providing the seat capacity of an itinerary, all booking class together
<i>CapaItineraryerClass</i>	Function providing the seat capacity of an itinerary per booking class
<i>ClosingTime</i>	A closing time of an airport corresponding to the night ban curfew of flights during the night (if a night ban curfew is enforced at the airport). The opening and closing times might depend of the airline
<i>Crew</i>	Set of all crews operating a flight caught in the optimization definition
<i>c</i>	Crew index
$Crew_{>LTOT}^{Opti}$	Set of crews impacting the following operations in the new planning, as their duty time ends after their respective LTOT (Last Time Of Touchdown)
$Crew_{Fatigue}^{Opti}$	Set of crews that could be subject to fatigue in the new planning, at their end of duty in the new planning is later than the initially planned one, but still happening before their respective LTOT
<i>CrewOwnership</i>	Function providing the affiliation of crew to an airline
<i>D</i>	Set of durations, in minutes
<i>DebriefingTime</i>	Function providing the debriefing time compulsory after the last flight is operated
$Dep_{Ini}$	Function providing the departure time of a flight
$Dep_{Rel}$	Function providing the departure time of a flight $k_{fp}$ according to the departure slot assigned in the new planning
$DepTimeIti$	Function providing the departure time of the first flight of the itinerary at the planned origin
$DesIti$	Function providing the destination airport of an itinerary
<i>DepAirport</i>	Function providing the airport of departure of a flight
<i>DesAirport</i>	Function providing the destination airport of a reservation
<i>DesArrivalTime</i>	Function providing the arrival time at the destination airport,
<i>Dist</i>	Function providing the distance in km between the two airports



$dSeuil$	Function providing the maximum delay in minutes that is acceptable for a reservation $s$ without triggering financial compensation to be paid by the airline to the passengers, as from the law EUC261
$DurationThresholdReserveF$	Function providing the minimum amount of time (in minutes) during which an aircraft of type $m$ should stay on-ground with no flights nor maintenance event allocated, to be considered as a reserve
$DutyCrewEnd_{Ini}$	Function providing the initially planned end of duty
$DutyCrewEnd_{Rel}$	Function providing the new end of duty time in the solution, which might be different due to delayed flights operated by this crew
$DutyCrewStart$	Function providing the start of the duty,
$DutyTime$	Function providing the duty time of a crew $c$ at time $t$
$DutyTimeLimit_{EASA}$	Function providing the legal maximum time of duty from EASA
$DutyTimeLimit$	Function providing the legal maximum time of duty from the airline $i$
$DutyTimeValidity$	Function proving crew's validity towards the airline's and EASA's rules
$E_i^{Opti}$	Set of the flights scheduled during the optimization time window and operated by the airline $i$
$E^{Incident}$	Set of flights scheduled during the disruption time window
$E^{Late}$	Function providing the set of flights impacting the following operations in the new planning due to landing later than their LTOT
$E^{Opti} = \{k_{fp}\}$	Set of the disrupted flights $k_{fp}$ on the optimization time window
$E^{OptiCNL}$	Function providing the set of flights cancelled in the new planning in the optimization window
$e$	Index on $PeakTime_i$
$ExtraordinaryEvent$	As from the European Definition "if the disruption is caused by extraordinary circumstances which could not have been avoided even if all reasonable measures had been taken" (European Parliament, 2004). This information releases (or not) the compulsory financial compensation to the passengers in case of important delays, for all flights from or to Europe, as from the EUC261 law
$Flight^{NoCNL}$	The information that a flight cannot be cancelled: all flights in Europe must comply with the 80/20 airport slot rules
$FlightTime$	Function providing its flight time

Appendix A - Mathematical Notation Table

$GroundTime$	The function providing the given minimum ground time in minutes between two flights operated by a specific aircraft type (for turnaround processes such as de-boarding, fueling, cleaning, etc.)
$HUB_i$	The main hub airport from which an airline $i$ operates
$i \in \{1, \dots, NBairITot\}$	Airlines index
$Itinerary_{mi}$	Function providing the initial booked itinerary (sequence of flights booked to reach the destination from the origin airport)
$k_{fp}$	A flight belonging to the optimization period
$LastFlightCrew$	Function providing the last flight operated by a crew as initially planned in the roster
$LTOT$	Function providing the Last Time Of Touchdown, which is the latest time at which the flight must arrive at gate before impacting the following operations through crew or aircraft rotations, or passengers connection
$LTOTCrew$	Function providing the latest time at which a crew must arrive with their last planned flight before impacting the next operations and roster time (to calculate the operational influence of delays), in respect with the minimum resting time to guarantee to the crew before next duty)
$MinConnTime$	A minimum connecting time corresponding to the legal minimum time that a passenger must have to connect between two flights in the airport (depends of the airport structure between the gates)
$NextFlight$	Function providing the next flight operated on the same aircraft, which is enabling operational impact calculation of delay
$NextFlightIti$	Function providing the next flight booked in the reservation's itinerary
$NBCancGroup_{Incident}$	Function providing the amount of flight cancelled for the group in the new planning on the disruption time window
$NBCancReqGroupMin$	Minimum number of cancellations required for the considered group of airline
$NBCancGroup_{Opti}$	Function providing the amount of flight cancelled for the group in the new planning on the optimization time window
$NbFlights$	Function providing the number of flights in an itinerary
$NBToken$	The number of tokens allocated by an airline to prioritize certain flights that are important for any reason, which might not be recognized through the data (operational situation awareness)

$NBFlightPushedOutIncidentSol_i$	Function providing the number of flights operated by an airline $i$ initially planned in the disruption window, and delayed outside of the disruption window in the new planning
$NBFlightSol_i$	Function providing the number of planned flights operated by an airline $i$ in the new planning
$NBPax_{Ini}$	Function providing the number of passengers initially booked on the flight per booking class (identified by $pt$ )
$NBPax$	Function providing the number of passengers booked in a reservation
$OpeningTime$	An opening time of an airport corresponding to the night ban curfew of flights during the night (if a night ban curfew is enforced at the airport). The opening and closing times might depend on the airline
$OrgIti$	Function providing the origin airport of an itinerary
$OrgAirport$	Function providing the origin airport of a reservation
$OrgDepartureTime$	Function providing the original scheduled time of departure from the origin airport
$PaxType$	The set of classes on which a passenger can book a seat (First, Business, Premium Economy, and Economy), from which an element is noted $pt$
$PaxTypeF$	Function providing the initial booking class of a reservation
$PaxTypeItiF$	Function providing the booking class that the passengers booked for the itinerary
$pt$	$PaxType$ index
$PaxPrio$	Set of different priorities that a passenger could have, $pp$ is an element of $PaxPrio$
$PrioPaxF$	Function providing the initial priority of a reservation
$pp$	$PaxPrio$ index
$PaxCategory$	The set of categories, defined from the sets $PaxType$ and $PaxPrio$ , for convenience purposes in the indicators calculations and grouped as from experts' request, $pc$ is an element of $PaxCategory$
$PaxCategoryF$	Function providing the initial category of a reservation
$pc$	$PaxCategory$ index
$PeakTime_i$	Set of peak traffic time of $HUB(i)$ , from which an element is noted $e$
$PeakTimeF$	Function providing the peak traffic times begin and end
$RedCap$	A requested reduction of capacity in percent

Appendix A - Mathematical Notation Table

<i>Reservation</i>	Set of reservation with one planned flight at least disrupted by the considered problem
<i>ResaPert</i>	The set of reservations impacted by the defined disruption (i.e., having a flight subject to a schedule change in comparison with the initial schedule or a cancellation)
<i>ResaPert<sub>DHC</sub></i>	Function providing the crew flying as deadhead crew on cancelled flights
<i>ResaPert<sub>ini</sub><sup>k<sub>fp</sub></sup></i>	Function providing the reservation initially planned on a flight <i>k<sub>fp</sub></i>
<i>ResaPertCtegrory<sub>pc</sub></i>	Set of reservation with a specific category
<i>ResaPertFlightIni<sub>v</sub></i>	Set of reservations disrupted initially booked on the itinerary <i>v</i>
<i>ResaPertItinerary<sub>v</sub></i>	Set of all reservation assigned to itinerary <i>v</i> by the decision variable for the passengers
<i>ResaPertType<sub>pt</sub></i>	Set of disrupted reservations with passenger of a specific booking class <i>pt</i>
<i>Rotation</i>	Function providing the flights depending on each other: several flights are considered in a same rotation if they are operated by the same aircraft, and in the same sequence from the hub to the hub. Thus, a change of schedule on one of the flights could impact the other one
<i>Schedule</i>	Set of flights operated by the airlines belonging to the considered group, of which an element is noted <i>k</i>
<i>Schedule<sub>i</sub></i>	Set of flights operated by an airline <i>i</i>
<i>s</i>	<i>Reservation</i> index
<i>satisCosts</i>	Function providing the indication if a reservation is assigned on an itinerary causing costs because of delay or downgrade
<i>Slot = {5,10, ...,1440}</i>	Set of departure and arrival slots, as in Europe the times slots are reported every 5 min
<i>T</i>	Set of times in minutes in a day, in UTC
<i>TailOwnership</i>	Function providing the information to which airline an aircraft belongs to
<i>TailProperty</i>	Function providing the information about the aircraft type
<i>TailReserve</i>	Function enabling to quantify if an aircraft is available as a reserve
<i>TAvailBegin</i>	Function providing the beginning time of the aircraft availability with no flights nor maintenance event planned during this time
<i>TAvailEnd</i>	Function providing the ending time of the aircraft availability with no flights nor maintenance event planned during this time

$TaxiInTime$	Function providing the taxi in time, which corresponds to the time between the push-back from the tarmac and the take-off time,
$TaxiOutTime$	Function providing the taxi out, which corresponds to the period between the landing and the arrival at the tarmac
$TdisruptionBegin(XYZ)$	The beginning time of the disruption
$TdisruptionEnd(XYZ)$	The ending time of the disruption
$TOptiBegin(XYZ)$	The beginning time of the optimization
$TOptiEnd(XYZ)$	The ending time of the optimization
$V$	The set of all itineraries possible, between all pairs of origins and destinations of the passengers considered in the set <i>Reservation</i>
$v$	Index on the set $V$
$V_{Rel}$	The set of alternative itineraries feasible with the new planning for the reservations
$V_s$	The set of feasible alternative itineraries realizable for a specific reservation $s$
$V_{Ini}$	The set of initially planned itineraries for the considered reservations in <i>Reservation</i>
$XYZ$	A disrupted airport
$\beta \in D$	Maximum number of minutes between the initial departure time and the proposed new departure time if the new slot is before the initial one (by default 20min at SWISS)
$\delta \in \mathbb{R}$	Number of flights allowed to be delayed outside of the disruption timeframe

## B.AHP Criteria Tree

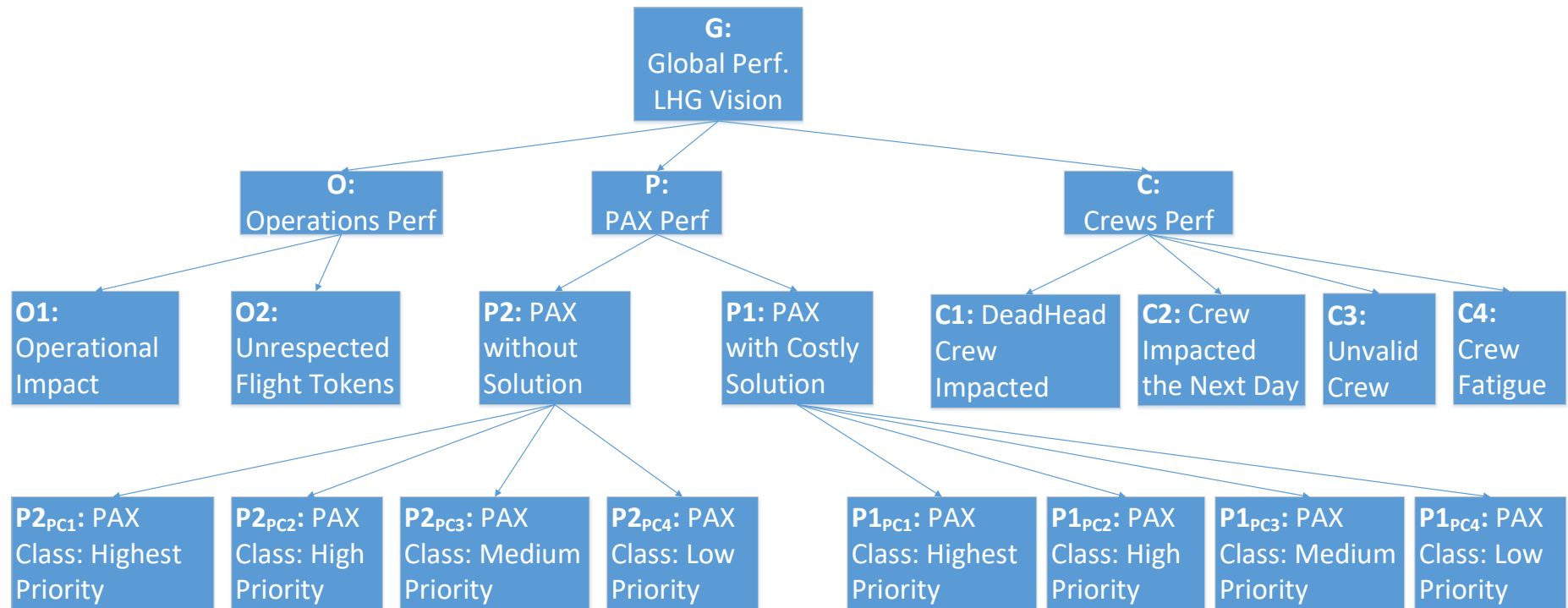

# C.Long-Term Inequity Concept Analysis



## a. Equity Threshold Identification

Conducting experimentations on different situations (see Table 31) enabled us to identify the right Theil index threshold to assess the equity balance. It must be noted that the global performances in the table presented below in black are  $Global_{perf} = 1 - average(Local_{perf})$  as the Theil index prerequisite is that the performances to compare are following the trend: the bigger, the better (as it was developed for salary equity measures initially).

Table 31: Summary of tested scenarios for the inequity threshold identification

ID	Short description	Nb of instances	Global situation per airline																
1	Randomly (uniform law) generated	34 instances	<table border="1"> <thead> <tr> <th></th> <th>LX</th> <th>OS</th> <th>SN</th> <th>LH FRA</th> <th>LH MUC</th> <th>CL</th> <th>WK</th> </tr> </thead> <tbody> <tr> <td><b>global</b></td> <td>0.515789</td> <td>0.50408</td> <td>0.475248</td> <td>0.488757</td> <td>0.490906</td> <td>0.507711</td> <td>0.512539</td> </tr> </tbody> </table> <p>Performance Distribution per airline on all GOM instances (the lower, the better) Experimentation :randomly generated</p>		LX	OS	SN	LH FRA	LH MUC	CL	WK	<b>global</b>	0.515789	0.50408	0.475248	0.488757	0.490906	0.507711	0.512539
			LX	OS	SN	LH FRA	LH MUC	CL	WK										
<b>global</b>	0.515789	0.50408	0.475248	0.488757	0.490906	0.507711	0.512539												
TH = 0.000374																			
2	Randomly generated, with one airline loosing badly (min perf = 0.5)	34 instances	<table border="1"> <thead> <tr> <th></th> <th>LX</th> <th>OS</th> <th>SN</th> <th>LH FRA</th> <th>LH MUC</th> <th>CL</th> <th>WK</th> </tr> </thead> <tbody> <tr> <td><b>global</b></td> <td>0.245228</td> <td>0.501996</td> <td>0.5104</td> <td>0.485822</td> <td>0.514755</td> <td>0.509118</td> <td>0.534584</td> </tr> </tbody> </table> <p>Performance Distribution per airline on all GOM instances (the lower, the better) Experimentation :LXLoosing</p>		LX	OS	SN	LH FRA	LH MUC	CL	WK	<b>global</b>	0.245228	0.501996	0.5104	0.485822	0.514755	0.509118	0.534584
			LX	OS	SN	LH FRA	LH MUC	CL	WK										
<b>global</b>	0.245228	0.501996	0.5104	0.485822	0.514755	0.509118	0.534584												
TH = 0.023057																			
3	Randomly generated, with two airlines loosing badly (min perf = 0.5)	34	<table border="1"> <thead> <tr> <th></th> <th>LX</th> <th>OS</th> <th>SN</th> <th>LH FRA</th> <th>LH MUC</th> <th>CL</th> <th>WK</th> </tr> </thead> <tbody> <tr> <td><b>global</b></td> <td>0.251909</td> <td>0.47867</td> <td>0.463455</td> <td>0.507926</td> <td>0.247978</td> <td>0.495821</td> <td>0.49305</td> </tr> </tbody> </table> <p>Performance Distribution per airline on all GOM instances (the lower, the better) Experimentation :LX_LHMUCLoosing</p>		LX	OS	SN	LH FRA	LH MUC	CL	WK	<b>global</b>	0.251909	0.47867	0.463455	0.507926	0.247978	0.495821	0.49305
			LX	OS	SN	LH FRA	LH MUC	CL	WK										
<b>global</b>	0.251909	0.47867	0.463455	0.507926	0.247978	0.495821	0.49305												
TH = 0.036706																			

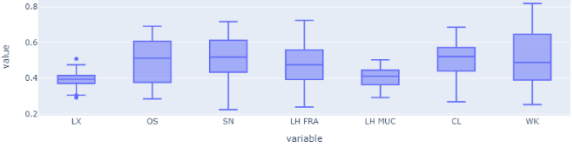
Appendix C - Long-Term Inequity Concept Analysis

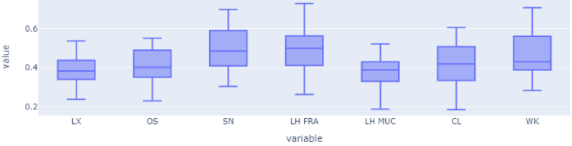
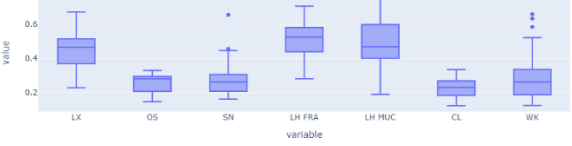
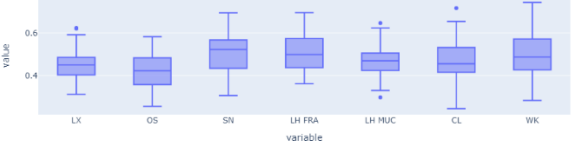
4	Randomly generated, with two airlines losing a bit (min perf = 0.2)	34 instances	<table border="1" data-bbox="683 210 1321 309"> <thead> <tr> <th></th> <th>LX</th> <th>OS</th> <th>SN</th> <th>LH FRA</th> <th>LH MUC</th> <th>CL</th> <th>WK</th> </tr> </thead> <tbody> <tr> <td><b>global</b></td> <td>0.393867</td> <td>0.500731</td> <td>0.514641</td> <td>0.479219</td> <td>0.408046</td> <td>0.513016</td> <td>0.518208</td> </tr> </tbody> </table> <p data-bbox="715 331 1166 365">Performance Distribution per airline on all GOM instances (the lower, the better) Experimentation :LX_LHMUCloosingABit</p> 		LX	OS	SN	LH FRA	LH MUC	CL	WK	<b>global</b>	0.393867	0.500731	0.514641	0.479219	0.408046	0.513016	0.518208
	LX	OS	SN	LH FRA	LH MUC	CL	WK												
<b>global</b>	0.393867	0.500731	0.514641	0.479219	0.408046	0.513016	0.518208												
5	Randomly generated, with one airline losing on half of the instances (min Perf 0.5) and winning on the other half (max Perf 0.5)	34 instances	<table border="1" data-bbox="683 560 1321 636"> <thead> <tr> <th></th> <th>LX</th> <th>OS</th> <th>SN</th> <th>LH FRA</th> <th>LH MUC</th> <th>CL</th> <th>WK</th> </tr> </thead> <tbody> <tr> <td><b>global</b></td> <td>0.507041</td> <td>0.495364</td> <td>0.537784</td> <td>0.492875</td> <td>0.509874</td> <td>0.509665</td> <td>0.484407</td> </tr> </tbody> </table> <p data-bbox="715 678 1166 712">Performance Distribution per airline on all GOM instances (the lower, the better) Experimentation :LXlosingHalfAndWinningHalf</p> 		LX	OS	SN	LH FRA	LH MUC	CL	WK	<b>global</b>	0.507041	0.495364	0.537784	0.492875	0.509874	0.509665	0.484407
	LX	OS	SN	LH FRA	LH MUC	CL	WK												
<b>global</b>	0.507041	0.495364	0.537784	0.492875	0.509874	0.509665	0.484407												
6	Randomly generated with half of the airlines losing a bit and then inverse (min perf 0.2)	34 instances	<table border="1" data-bbox="683 1008 1321 1084"> <thead> <tr> <th></th> <th>LX</th> <th>OS</th> <th>SN</th> <th>LH FRA</th> <th>LH MUC</th> <th>CL</th> <th>WK</th> </tr> </thead> <tbody> <tr> <td><b>global</b></td> <td>0.388537</td> <td>0.410064</td> <td>0.496386</td> <td>0.48525</td> <td>0.381563</td> <td>0.423803</td> <td>0.47417</td> </tr> </tbody> </table> <p data-bbox="715 1104 1166 1137">Performance Distribution per airline on all GOM instances (the lower, the better) Experimentation :HalfAirlinesLoosingABitPerfMin200</p> 		LX	OS	SN	LH FRA	LH MUC	CL	WK	<b>global</b>	0.388537	0.410064	0.496386	0.48525	0.381563	0.423803	0.47417
	LX	OS	SN	LH FRA	LH MUC	CL	WK												
<b>global</b>	0.388537	0.410064	0.496386	0.48525	0.381563	0.423803	0.47417												
7	Randomly generated with half of the airline losing a lot and then inverse (min perf 0.5)	34 instances	<table border="1" data-bbox="683 1344 1321 1420"> <thead> <tr> <th></th> <th>LX</th> <th>OS</th> <th>SN</th> <th>LH FRA</th> <th>LH MUC</th> <th>CL</th> <th>WK</th> </tr> </thead> <tbody> <tr> <td><b>global</b></td> <td>0.442886</td> <td>0.257854</td> <td>0.282494</td> <td>0.507357</td> <td>0.46477</td> <td>0.228781</td> <td>0.290934</td> </tr> </tbody> </table> <p data-bbox="715 1440 1166 1473">Performance Distribution per airline on all GOM instances (the lower, the better) Experimentation :HalfAirlinesLoosingALotPerfMin500</p> 		LX	OS	SN	LH FRA	LH MUC	CL	WK	<b>global</b>	0.442886	0.257854	0.282494	0.507357	0.46477	0.228781	0.290934
	LX	OS	SN	LH FRA	LH MUC	CL	WK												
<b>global</b>	0.442886	0.257854	0.282494	0.507357	0.46477	0.228781	0.290934												
8	Randomly generated with half of the airline losing a bit (minimum perf 0.1)	34 instances	<table border="1" data-bbox="683 1680 1321 1778"> <thead> <tr> <th></th> <th>LX</th> <th>OS</th> <th>SN</th> <th>LH FRA</th> <th>LH MUC</th> <th>CL</th> <th>WK</th> </tr> </thead> <tbody> <tr> <td><b>global</b></td> <td>0.449318</td> <td>0.420635</td> <td>0.507414</td> <td>0.50724</td> <td>0.471239</td> <td>0.466393</td> <td>0.501209</td> </tr> </tbody> </table> <p data-bbox="715 1798 1166 1832">Performance Distribution per airline on all GOM instances (the lower, the better) Experimentation :HalfAirlinesLoosingABitPerfMin100</p> 		LX	OS	SN	LH FRA	LH MUC	CL	WK	<b>global</b>	0.449318	0.420635	0.507414	0.50724	0.471239	0.466393	0.501209
	LX	OS	SN	LH FRA	LH MUC	CL	WK												
<b>global</b>	0.449318	0.420635	0.507414	0.50724	0.471239	0.466393	0.501209												

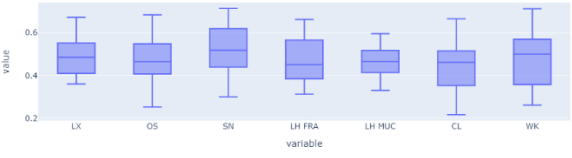
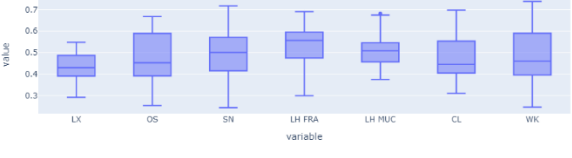
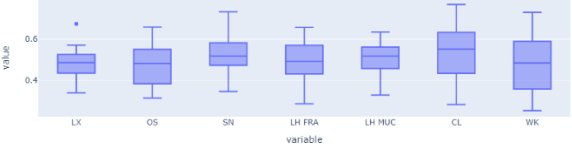
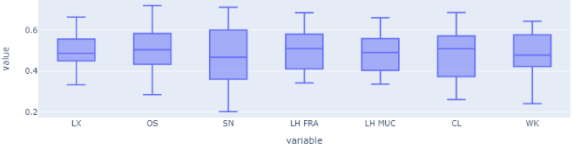
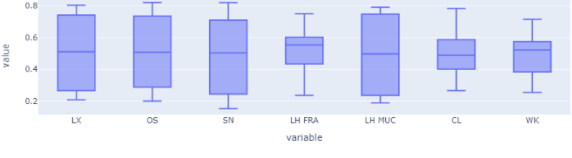

9	Randomly generated with half of the airlines losing a bit (min perf 0.05)	34 instances	<table border="1" style="width: 100%; text-align: center;"> <thead> <tr> <th></th> <th>LX</th> <th>OS</th> <th>SN</th> <th>LH FRA</th> <th>LH MUC</th> <th>CL</th> <th>WK</th> </tr> </thead> <tbody> <tr> <td><b>global</b></td> <td>0.483945</td> <td>0.473405</td> <td>0.522858</td> <td>0.476862</td> <td>0.467122</td> <td>0.449681</td> <td>0.488589</td> </tr> </tbody> </table> <p>Performance Distribution per airline on all GOM instances (the lower, the better) Experimentation :HalfAirlinesLosingABitPerMin50</p> 		LX	OS	SN	LH FRA	LH MUC	CL	WK	<b>global</b>	0.483945	0.473405	0.522858	0.476862	0.467122	0.449681	0.488589
	LX	OS	SN	LH FRA	LH MUC	CL	WK												
<b>global</b>	0.483945	0.473405	0.522858	0.476862	0.467122	0.449681	0.488589												
10	Randomly generated with one of the airline losing a bit (min perf 0.1)	34 instances	<table border="1" style="width: 100%; text-align: center;"> <thead> <tr> <th></th> <th>LX</th> <th>OS</th> <th>SN</th> <th>LH FRA</th> <th>LH MUC</th> <th>CL</th> <th>WK</th> </tr> </thead> <tbody> <tr> <td><b>global</b></td> <td>0.436025</td> <td>0.468316</td> <td>0.499269</td> <td>0.535708</td> <td>0.512619</td> <td>0.481353</td> <td>0.486017</td> </tr> </tbody> </table> <p>Performance Distribution per airline on all GOM instances (the lower, the better) Experimentation :LXlosingABit100</p> 		LX	OS	SN	LH FRA	LH MUC	CL	WK	<b>global</b>	0.436025	0.468316	0.499269	0.535708	0.512619	0.481353	0.486017
	LX	OS	SN	LH FRA	LH MUC	CL	WK												
<b>global</b>	0.436025	0.468316	0.499269	0.535708	0.512619	0.481353	0.486017												
11	Randomly generated with one of the airline losing a bit (min perf 0.05)	34 instances	<table border="1" style="width: 100%; text-align: center;"> <thead> <tr> <th></th> <th>LX</th> <th>OS</th> <th>SN</th> <th>LH FRA</th> <th>LH MUC</th> <th>CL</th> <th>WK</th> </tr> </thead> <tbody> <tr> <td><b>global</b></td> <td>0.481359</td> <td>0.479704</td> <td>0.520633</td> <td>0.488255</td> <td>0.503284</td> <td>0.53806</td> <td>0.480154</td> </tr> </tbody> </table> <p>Performance Distribution per airline on all GOM instances (the lower, the better) Experimentation :LXlosingABit50</p> 		LX	OS	SN	LH FRA	LH MUC	CL	WK	<b>global</b>	0.481359	0.479704	0.520633	0.488255	0.503284	0.53806	0.480154
	LX	OS	SN	LH FRA	LH MUC	CL	WK												
<b>global</b>	0.481359	0.479704	0.520633	0.488255	0.503284	0.53806	0.480154												
12	Randomly generated with one of the airline losing a bit (min perf 0.01)	34 instances	<table border="1" style="width: 100%; text-align: center;"> <thead> <tr> <th></th> <th>LX</th> <th>OS</th> <th>SN</th> <th>LH FRA</th> <th>LH MUC</th> <th>CL</th> <th>WK</th> </tr> </thead> <tbody> <tr> <td><b>global</b></td> <td>0.503769</td> <td>0.509584</td> <td>0.483804</td> <td>0.504476</td> <td>0.486365</td> <td>0.484922</td> <td>0.473239</td> </tr> </tbody> </table> <p>Performance Distribution per airline on all GOM instances (the lower, the better) Experimentation :LXlosingABit10</p> 		LX	OS	SN	LH FRA	LH MUC	CL	WK	<b>global</b>	0.503769	0.509584	0.483804	0.504476	0.486365	0.484922	0.473239
	LX	OS	SN	LH FRA	LH MUC	CL	WK												
<b>global</b>	0.503769	0.509584	0.483804	0.504476	0.486365	0.484922	0.473239												
13	Randomly generated with half of the airline losing (min perf 0.5) and winning (max perf 0.5) every two instances	34 instances	<table border="1" style="width: 100%; text-align: center;"> <thead> <tr> <th></th> <th>LX</th> <th>OS</th> <th>SN</th> <th>LH FRA</th> <th>LH MUC</th> <th>CL</th> <th>WK</th> </tr> </thead> <tbody> <tr> <td><b>global</b></td> <td>0.504344</td> <td>0.515094</td> <td>0.48533</td> <td>0.524829</td> <td>0.494816</td> <td>0.499727</td> <td>0.497468</td> </tr> </tbody> </table> <p>Performance Distribution per airline on all GOM instances (the lower, the better) Experimentation :HalfAirlinesLosingEvery2Instances</p> 		LX	OS	SN	LH FRA	LH MUC	CL	WK	<b>global</b>	0.504344	0.515094	0.48533	0.524829	0.494816	0.499727	0.497468
	LX	OS	SN	LH FRA	LH MUC	CL	WK												
<b>global</b>	0.504344	0.515094	0.48533	0.524829	0.494816	0.499727	0.497468												

From the experiments above, we could conclude depending on the sensitivity that the users wish. If the Theil index should be sensitive to one airline having local performances with a

## Appendix C - Long-Term Inequity Concept Analysis

slight imbalance (minimum of performances always 5% higher than the ones from the other airlines), the Theil index threshold to consider global equity should be 0.0009. If the users would like the Theil index to be sensitive to one airline having local performances 1% higher than the other ones, the Theil index threshold to consider global equity should be 0.0003

Table 32: Proposed Theil index equity threshold according to misbalanced situation

% of local performance difference with the other ones	Proposed Theil index inequity threshold
5	0.0009
1	0.0003

### b. Inequity Weight Influence on Group Rankings

#### Case 1: Relatively similar airlines rankings:

Rank	Ranking for Airline A	Ranking for Airline B	Ranking for Airline C	Borda Point for A	Borda Points for B	Borda Points for C
1	S2	S2	S1	7	7	7
2	S3	S1_S3_S7	S2	6	5	6
3	S1	-	S7	5	-	5
4	S7	-	S3	4	-	4
5	S8	S8	S5	3	3	3
6	S4	S4	S8	2	2	2
7	S5	S5	S4	1	1	1
8	S6	S6	S6	0	0	0

ID	Rank points A	Weight A	Rank points B	Weight B	Rank point C	Weight C	Total Points without Inequity Weights	Total Points with Inequity Weights
S1	5	0.3	5	0.1	7	0.6	17	6.2
S2	7	0.3	7	0.1	6	0.6	20	6.4
S3	6	0.3	5	0.1	4	0.6	15	4.7
S4	2	0.3	2	0.1	1	0.6	5	1.4
S5	1	0.3	1	0.1	3	0.6	5	2.2
S6	0	0.3	0	0.1	0	0.6	0	0
S7	4	0.3	5	0.1	5	0.6	14	4.7
S8	3	0.3	3	0.1	2	0.6	8	2.4

Without Inequity Weights		With Inequity Weights	
Rank	Group ranking:	Rank	Group ranking:
1	S2	1	S2
2	S1	2	S1
3	S3	3	S7
4	S7	4	S3
5	S8	5	S8
6	S4/S5	6	S5
7	-	7	S4
8	S6	8	S6

Figure 60: Illustration of inequity weights influence on similar rankings.

Conclusion: on similar rankings among airlines, the inequity weights does not change so much the group ranking nor the consensus on the solution.

#### Case 2: highly disparate airlines rankings:

Rank	Ranking for Airline A	Ranking for Airline B	Ranking for Airline C	Borda Point for A	Borda Points for B	Borda Points for C
1	S1	S6	S8	7	7	7
2	S4	S7	S5	6	6	6
3	S6	S2	S3	5	5	5
4	S3	S3	S2	4	4	4
5	S2	S4	S7	3	3	3
6	S8	S1	S1	2	2	2
7	S5	S8	S4	1	1	1
8	S7	S5	S6	0	0	0

ID	Rank points A	Weight A	Rank points B	Weight B	Rank point C	Weight C	Total Points without Inequity Weights	Total Points with Inequity Weights
S1	7	0.3	2	0.1	2	0.6	11	3.5
S2	3	0.3	5	0.1	4	0.6	12	3.8
S3	4	0.3	4	0.1	5	0.6	13	4.6
S4	6	0.3	3	0.1	1	0.6	10	2.7
S5	1	0.3	0	0.1	6	0.6	7	3.9
S6	5	0.3	7	0.1	0	0.6	12	2.2
S7	0	0.3	6	0.1	3	0.6	9	2.4
S8	2	0.3	1	0.1	7	0.6	10	4.9

Without Inequity Weights		With Inequity Weights	
Rank	Group ranking:	Rank	Group ranking:
1	S3	1	S8
2	S2/S6	2	S3
3	-	3	S5
4	S1	4	S2
5	S4/S8	5	S1
6	-	6	S4
7	S7	7	S7
8	S5	8	S6

Figure 61: Illustration of inequity weights influence on different rankings.

Conclusion: the inequity weights can influence very well the group ranking towards the most disfavored airline’s wishes.

**Case 3: the chosen solution without inequity weights is ranked at the last position by the airline being the most disfavored globally.**

Rank	Ranking for Airline A	Ranking for Airline B	Ranking for Airline C	Borda Point for A	Borda Points for B	Borda Points for C
1	S1	S8	S6	7	7	7
2	S3	S1	S7	6	6	6
3	S5	S7	S2	5	5	5
4	S4	S5	S8	4	4	4
5	S2	S2	S3	3	3	3
6	S6	S3	S4	2	2	2
7	S8	S4	S5	1	1	1
8	S7	S6	S1	0	0	0

ID	Rank points A	Weight A	Rank points B	Weight B	Rank point C	Weight C	Total Points without Inequity Weights	Total Points with Inequity Weights
S1	7	0.3	6	0.1	0	0.6	13	2.7
S2	3	0.3	3	0.1	5	0.6	11	4.2
S3	6	0.3	2	0.1	3	0.6	11	3.8
S4	4	0.3	1	0.1	2	0.6	7	2.5
S5	5	0.3	4	0.1	1	0.6	10	2.5
S6	2	0.3	0	0.1	7	0.6	9	4.8
S7	0	0.3	5	0.1	6	0.6	11	4.1
S8	1	0.3	7	0.1	4	0.6	12	3.4

Without Inequity Weights		With Inequity Weights	
Rank	Group ranking:	Rank	Group ranking:
1	S1	1	S6
2	S8	2	S2
3	S2/S3/S7	3	S7
4	-	4	S3
5	-	5	S8
6	S5	6	S1
7	S6	7	S4/S5
8	S4	8	-

Figure 62: Illustration of inequity weights influence on contradictory rankings.

Conclusion: the airline, which ranked S1 at the last position, being the most disfavored one and thus having an inequity weight of 0.6, its choice influence the group ranking and its preferred solution is chosen as the group ranking.

### c. Calibration of the Boltzmann SoftMax Operator

The goal of this part is to define the right *temperature* parameter of the Boltzmann SoftMax operator. A first set of tests on Figure 63, the difference between  $\tau=0.005$  and  $\tau=0.0001$  is marginal, while  $\tau=1$  is not bringing any important difference in the global equity index. We therefore focus the calibration for values of  $\tau$  between 0.1 and 0.005.

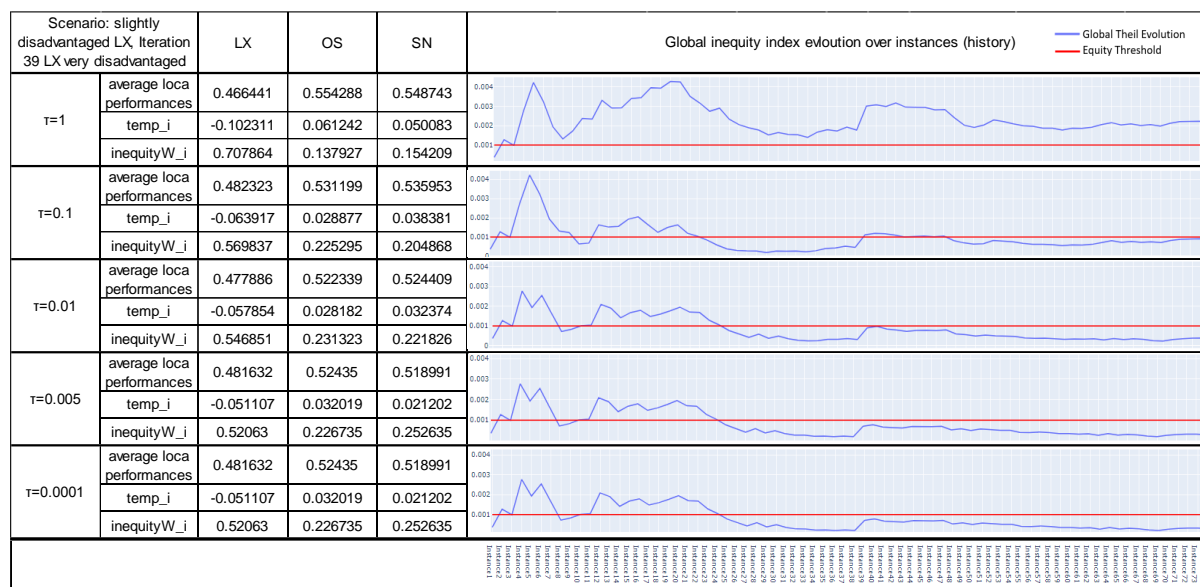

Figure 63: Illustration of the global equity index influenced by the inequity weights calculated with the  $\tau$  values of the Boltzmann SoftMax function.

The baseline is the inequity behavior without any inequity weights considered. The same scenario is used, namely the one with one airline having its best performance slightly capped in comparison with the other airlines (LX with random distribution of performances per criteria between 0.1 and 1 while the other airlines have a random distribution between 0 and 1). Perturbations are induced in iteration 39 and 49. We observe the solutions chosen (set of three solutions with different local airlines performances for each instance), the inequity weights evolution and global equity index.

As seen in the figure below (Figure 65), the values of  $\tau$  below 0.02 are heavily reducing the impact of the most favored airline SN (see the inequity weights evolution graph). We do not aim at suppressing almost completely one airline ranking influence, as it is a group process. From  $\tau=0.07$  and below, we see that the global inequity evolution is having a better ratio between the peaks in the first instances and the ones at iteration 39 and 49, which is important for a right sensitivity of the global index. The smaller  $\tau$  value is, the more changes in the group chosen solutions are observed (from 23 changes for  $\tau=0.07$  to 28 changes for  $\tau=0.02$ ). We decided to take a middle value  $\tau=0.04$  to propose a relatively fair balance between the inequity

weights “exaggerating” too much the influence of one airline over the group, but still enabling enough changes in the solutions chosen by the group to guarantee a good equity level.

# Appendix C - Long-Term Inequity Concept Analysis

Scenario: slightly disadvantaged LX, Iteration 39 LX very disadvantaged	Nb of group solution choice different than the baseline	Graph titles	
baseline, no inequity weights	-	Global inequity index evolution over instances	
		inequity weights evolution over instances	
		Performances distribution at last instance (74)	
$\tau=0.1$	18	Global inequity index evolution over instances	
		inequity weights evolution over instances	
		Performances distribution at last instance (74)	
$\tau=0.09$	19	Global inequity index evolution over instances	
		inequity weights evolution over instances	
		Performances distribution at last instance (74)	
$\tau=0.08$	20	Global inequity index evolution over instances	
		inequity weights evolution over instances	
		Performances distribution at last instance (74)	
$\tau=0.07$	23	Global inequity index evolution over instances	
		inequity weights evolution over instances	
		Performances distribution at last instance (74)	
$\tau=0.06$	23	Global inequity index evolution over instances	
		inequity weights evolution over instances	
		Performances distribution at last instance (74)	
$\tau=0.05$	24	Global inequity index evolution over instances	
		inequity weights evolution over instances	
		Performances distribution at last instance (74)	

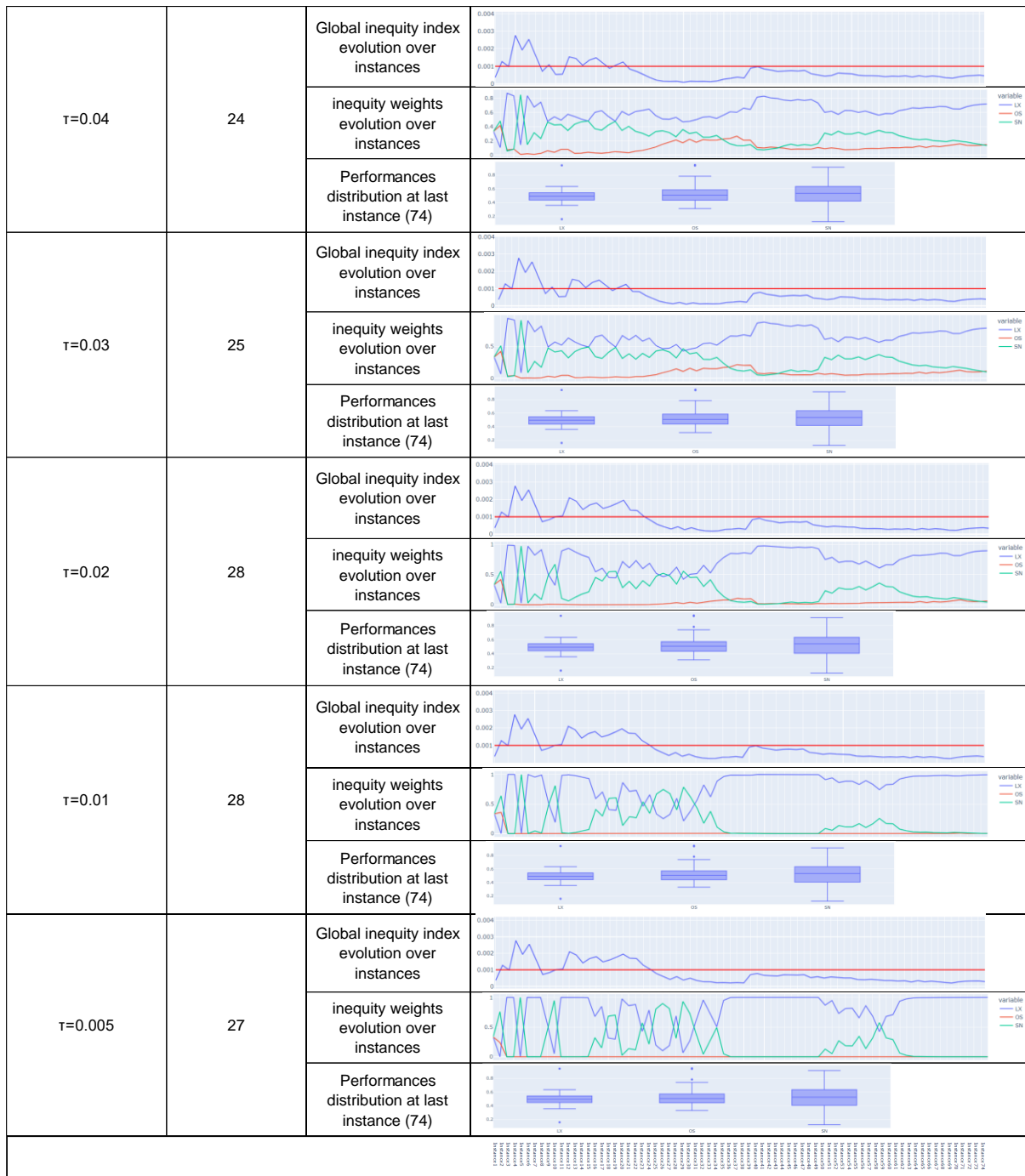

Figure 64: Sensitivity Analysis of the  $\tau$  parameter of the Boltzmann SoftMax operator.

## D. Particle Swarm Optimization Calibration

### a. Large Scale Calibration

Based on the literature review, the large-scale calibration of 2,200 test cases was run with the parameters range presented in Table 25 (p.152).

The calibration was run on the same instance of problem. In 2019, numerous ATC strikes happened in France, and the data of all Lufthansa Group airlines for their planned flights and passengers booked on it were retrieved. Some data cleaning were necessary to ensure the right formatting and consistency of data. Additionally, basic crew data were added – not related to any real data, as those are sensitive data that cannot be even accessed by some airlines. The static data for the calibration were consisting in 18 flights flying to or from Paris Charles de Gaulle (CDG), with 65 possible statuses (up to 300 minutes of delay), and 1,782 passengers booked initially on the flights. To verify the optimality of the PSO, the objective function was simplified to easily compute what the optimum was. It consisted in a calculation between the delay assigned compared to the Max Delay and the number of passengers of each category (use of the AHP weights). These incentives the PSO to cancel the flights with the least number of passengers and bring all other flights to a status below status 7 (less than 15 minutes delay, which is one of the definitions for punctuality). It is worth reminding that we are in a minimization problem. Therefore, the smallest the performance of the solution proposed, the better the PSO performed. The PSO were running with a limit of 700 iterations and/or 4 minutes.

The outputs of the calibration are presented below. Figure 65 shows quite accurately that the best solutions are found for an initial  $w$  coefficient initialized to the value 1.0. Figure 66 shows also clear results with initial  $c_1$  and  $c_2$  to be initialized at the maximum value tested: 1.5. Figure 67 shows that the smallest the difference between  $w_{Ini}$  and  $w_{final}$  (in the figure represented by the linear decreasing coefficient  $a_w = \frac{(w_{final} - w_{Ini})}{NbIterations}$ ), the better performances the PSO reaches.

This coefficient is supporting the exploration. It teaches us that the important value is not the final  $w$  at the last iteration, but truly the decreasing linear coefficient, that influence the PSO performances. This linear decrease is subject to an extension of the calibration in the second calibration step. Figure 68 is not enough to conclude on a better parameter than another one, except that having more particles in the swarm is not necessarily a good option (a 25-particles swarm seems to have the worst performances, and a 20-particles swarm seems to have quite a



variance in the results reached by the PSO). However, Figure 69 and Figure 70 show the relation between the number of particles, the amount of neighbors with which a particle communicates and the amount of iterations needed to reach for the first time the best performance found.  $(RING,N,-X,X)$  corresponds to a communication with the  $X$  particles “before” and the  $X$  particles “after” the particle itself in a ring topology for a swarm of  $N$  particles (see section 8.2.2). From Figure 69, a first early conclusion is that a topology of communication with the 2 particles before and 2 after  $(RING,N,-2,2)$  reaches better results as with a communication only with 1 particle before and after. One can also notice, that the variability observed for 20-particles swarm is linked with the communication topology  $(RING,20,-1,1)$ . The best performances would be for a swarm of 10 particles, as the max value reached is the lowest one, as well as the median and Q3 values are slightly lower for 10 particles than for 15. Concerning the first iteration at which the best performance found by the swarm has been reached (see Figure 70), the more the swarm has particles, the sooner the best performance is found. Nevertheless, the best performance reached is in most of the cases found before 215 iterations. Thanks to parallelization, an iteration integrating the full passenger optimization and indicators calculations takes around 0.47 seconds per iteration for a CPU 11<sup>th</sup> Generation Intel Core TM i9, with 32GB RAM, processor 2.6 up to 5GHz and operating system windows. The ideal computation time being 2 minutes for the users (and up to 5 minutes considered as acceptable), at least 255 iterations can be calculated, and thus, in the worst case, that the best performance will always be reached and proposed to the user.

Figure 70 shows a clear trend that the more communication is allowed between particles, the better and the faster the swarm converges towards the good solution. Therefore, we refined this topology parameter to extend the communication to up to 4 particles before and after.

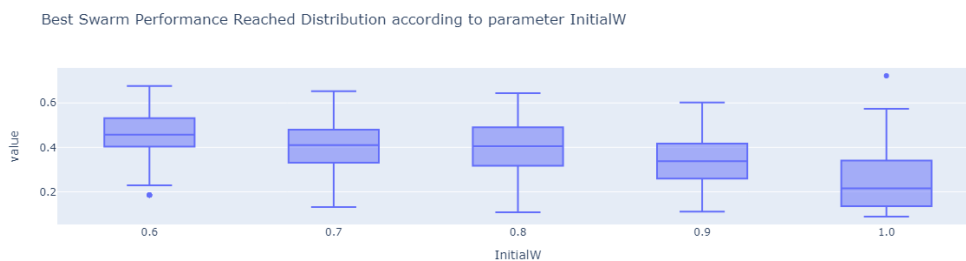

Figure 65: Distribution of the best performance found by the PSO according to initial  $w$ .

## Appendix D - Particle Swarm Optimization Calibration

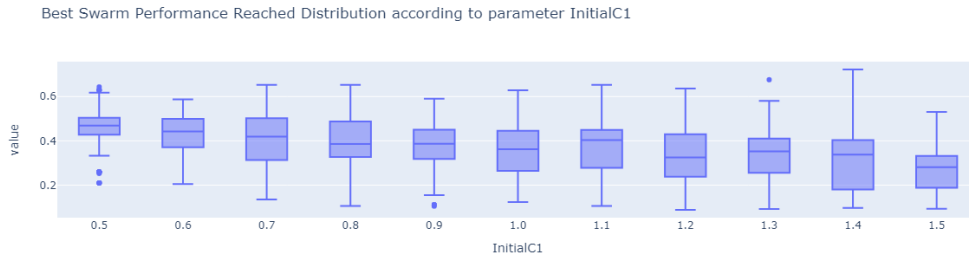

Figure 66: Distribution of the best performance found by the PSO according to the initial  $c_1$  and  $c_2$ .

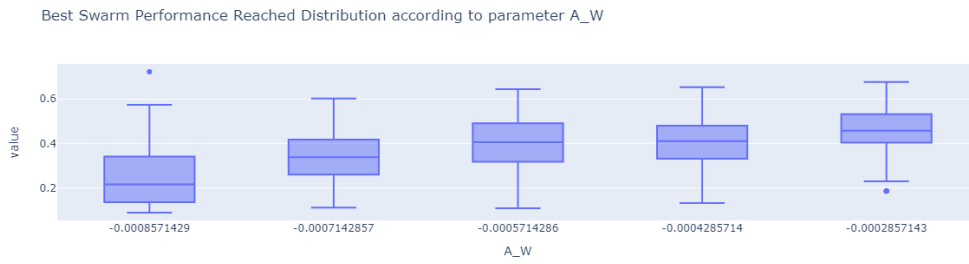

Figure 67: Distribution of the best performance reached by the PSO according to the linear coefficient  $a_w$

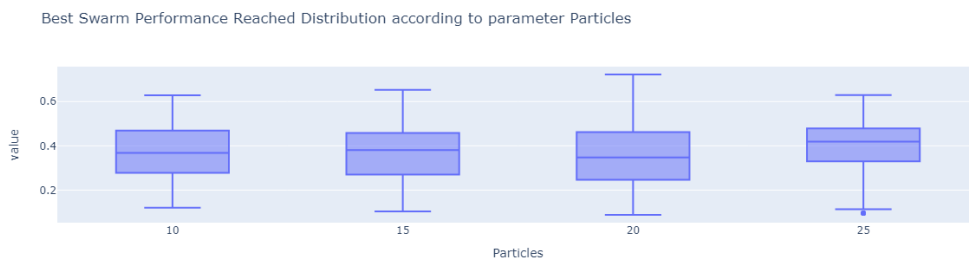

Figure 68: Distribution of the best performance reached by the PSO according to the number of particles.

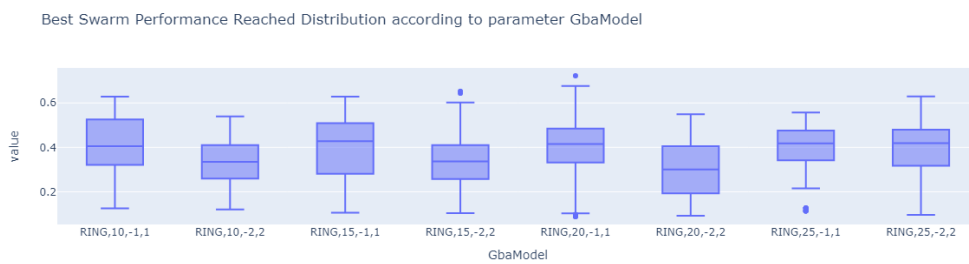

Figure 69: Distribution of the best performance reached by the PSO according to the ring topology.

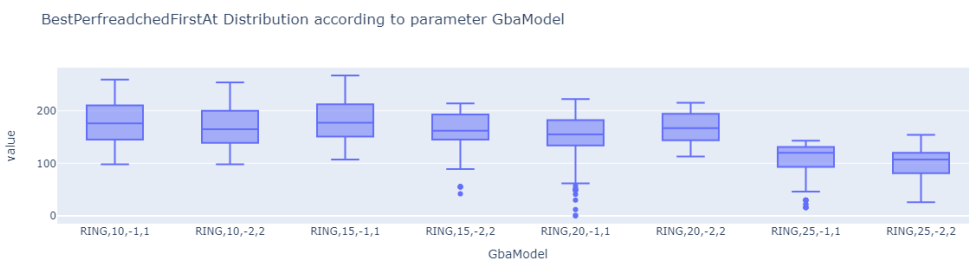

Figure 70: Distribution of the first iteration at which the best performance has been reached by the PSO.

### b. Calibration Extension

As explained above, an extension of the calibration took place for the parameters to refine the linear decrease of coefficients  $w$  and confirm the following hypothesis: the smaller the difference between  $w_{Ini}$  and  $w_{final}$ , the better. The same is tested for the coefficients  $c_1$  and  $c_2$ . We fixed  $w_{Ini} = 1.0$ , and tested  $w_{final}$  on new values (from 0.4 to 0.9) and continued fixing  $c_{1Final} = c_{2Final} = 2$ , varying  $c_{1Ini}$  and  $c_{2Ini}$  between 1.7 and 2. As the large-scale calibration showed a tendency for better results for  $-2/+2$  neighborhood, we extended it up to  $-4/+4$  to test bigger communications ring topology. The parameters set are presented in Table 33:

Table 33: parameters tested within the refinement calibration.

Parameters	Smallest value	Highest value	Step of increase	Number of scenarios needed	Specificities
$w_{Ini}$	1.0	1.0	0	0	W to decrease linearly from $w_{Ini}$ to $w_{final}$
$w_{final}$	0.4	0.9	-0.1	6	
$c_{1Ini}$ & $c_{2Ini}$	1.7	2	0.1	4	$c_1$ and $c_2$ to increase linearly to $c_{1final} = c_{2final} = 2$
Number of particles	10	20	5	3	
Number of particles connected in the ring	-1/+1	-4/+4	-	4	

Figure 72 shows clearly that the smallest the  $a_w = \frac{(w_{Ini}-w_{final})}{NbIterations}$  (linear coefficient of decrease for  $w$ ), the better the results, while Figure 71 does not indicate clear preferences and differences coefficient. Thus, there is no strong choice, and choosing one or the other does not influence greatly the PSO, contrary to the  $a_w$  value. Concerning the number of particles in a swarm and the communication topology (see Figure 73), the minimum of performances reached is by  $(RING, 15, -3, 3)$ , and the topologies with a swarm of 20 particles. However, a quick check on Figure 74 shows that a good trade-off of reaching the best performances with the most efficient computation time is proposed by a swarm size of 15 particles. Thus, to avoid a too fast convergence with no sufficient exploration phase, we decided to set the particle size to 15 and the ring topology to  $(RING, 15, -3, 3)$ .

## Appendix D - Particle Swarm Optimization Calibration

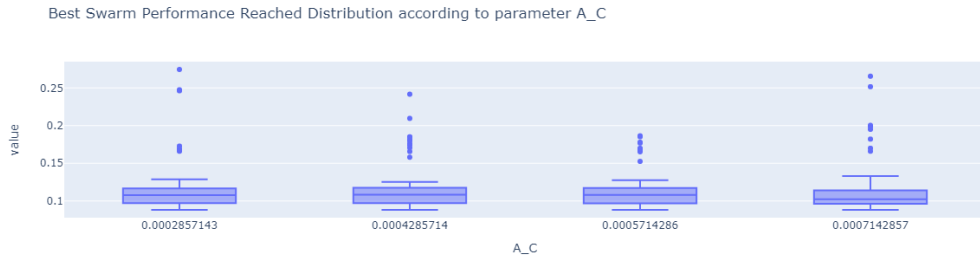

Figure 71: Distribution of the best performances reached according to  $a_c$  value

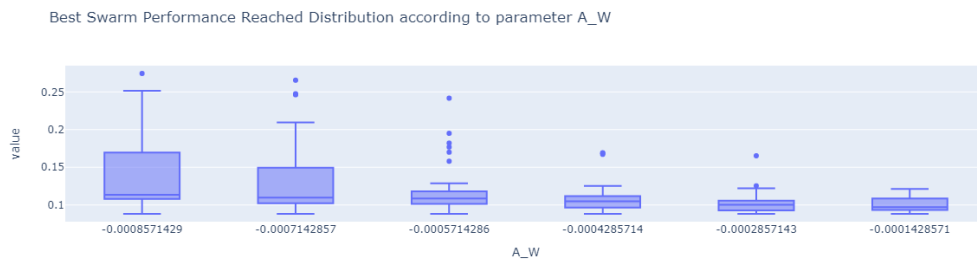

Figure 72: Distribution of the best performances reached according to  $a_w$  value

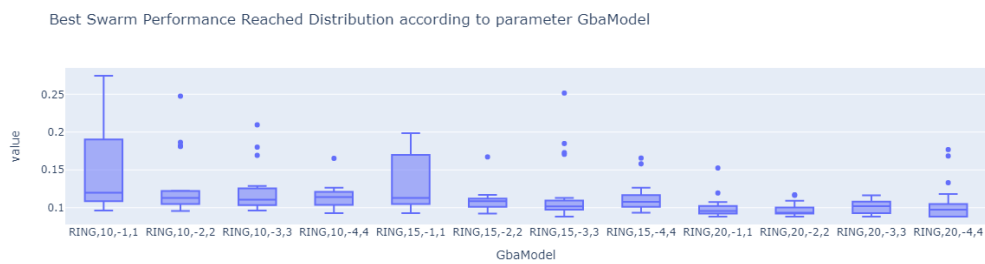

Figure 73: Distribution of the best performances according to the topology.

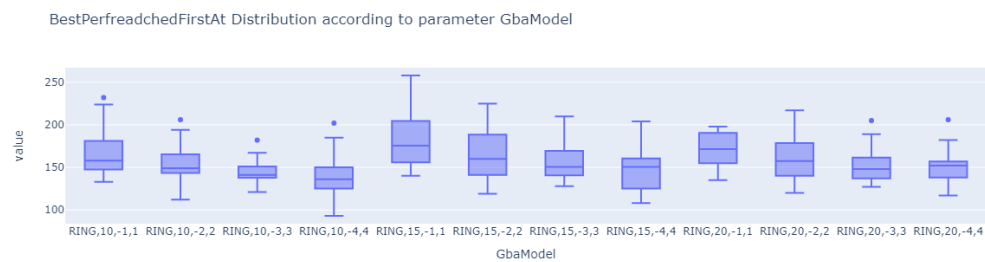

Figure 74 : Distribution of the first iteration at which the best performance has been reached for the first time, according to the topology.

### c. Parameters Set for the PSO

The clear trend of a small  $a_w$  bringing better performances led us to a final test:  $a_w = a_c = 0$ . This enabled us to confirm the trend seen in the large-scale calibration and its extension, that static coefficient might be better (no linear behavior anymore, as initially proposed by the founders of the PSO). This was tested with all other parameters fixed as suggested in section

b, except  $c_1 = c_2$  that we tested on values from 1.5 to 2, as no real decision were suggested from the last two calibrations rounds. It turned out that the best performance are reached with a fixed  $w = 1$  and  $c_1 = c_2 = 1.5$ . The two examples below illustrate the behavior of the swarm with slight increase/decrease of the coefficient versus static coefficient. The exploration rate is incomparable.

**Calibration parameters set:**

Linearly increasing  $c_1$  and  $c_2$  (respectively decreasing  $w$ ) coefficients.

- "Particles": 15,
- "GbaModel": "RING,15,-3,3",
- "InitialW": 1,
- "InitialC1": 1.5,
- "InitialC2": 1.5,
- "A\_W": -0.0002857143,
- "A\_C": 0.00057142857143,

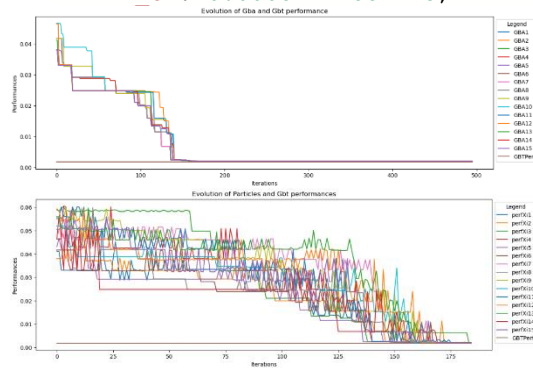

- ✓ 780 positions of the existing  $495 \times 15 = 7'425$  ones checked;
- ✓ 10% of existing positions tested;

Fixed  $w$  and  $c_1 = c_2$  coefficients parameters set:

- Particles": 15,
- "GbaModel": "RING,15,-3,3",
- "InitialW": 1,
- "InitialC1": 1.5,
- "InitialC2": 1.5,
- "A\_W": 0,
- "A\_C": 0,

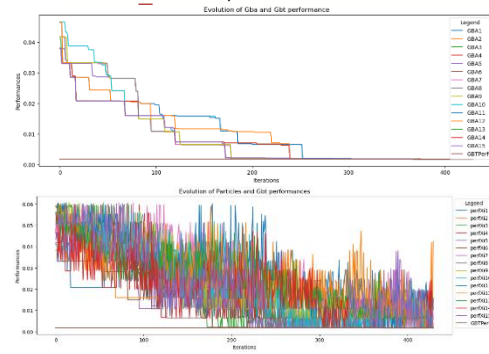

- ✓ 4'115 of the existing  $367 \times 15 = 5'505$  ones checked;
- ✓ 74% of existing positions tested;

The two graphs of each column show the evolution of the best performances found by the particles and their neighborhood (upper graph) and the particles performances through the iterations. The theoretical optimum (calculated thanks to the method mentioned in A.a) is the GBT Perf, represented by a brown line on the graphs.

The parameter set with fixed  $w, c_1$  and  $c_2$  shows a tremendously higher exploration rate (second graph on the right with all particles still exploring and not converging) but also show that the theoretical optimum is reached at iteration 367 after around 125 iterations with almost no improvement of the best solutions found by the particles and neighbors. The parameters set as

## Appendix D - Particle Swarm Optimization Calibration

from the calibration outputs, with linear coefficients, shows that all particles are converging towards the best solution found first at iteration 162, however this solution is not the theoretical optimum, even if very good, it is a local optimum. Comparing the number of positions checked (780 for the calibration parameter set against 4'115 positions for the fixed coefficients), this highlight that the most exploring parameter set find the optima.

Even if the convergence of all particles is not granted, the fixed coefficients  $w$ ,  $c_1$  and  $c_2$  parameters set tried out on 33 experimentations on the same instance (with different random initializations) performed far better (from 2 to 7 times better) than the one with slightly linear coefficients, according to the solutions reaching or approaching the theoretical optimum. The distribution of delta between the best reached performance and the theoretical optimum is presented for both parameters set in Figure 75 and Figure 76. Therefore, the parameter set with fixed coefficient are the one used for the industrial use case presented Chapter 10.

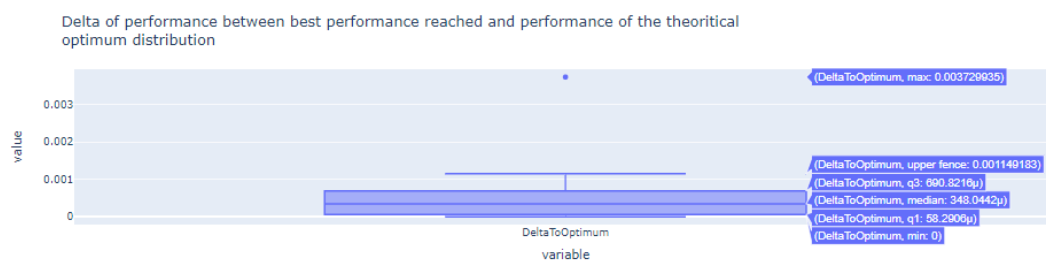

Figure 75: Distribution of the delta of performances reached by the swarm in comparison with the theoretical optimum solution with fixed  $w$ ,  $c_1$ ,  $c_2$

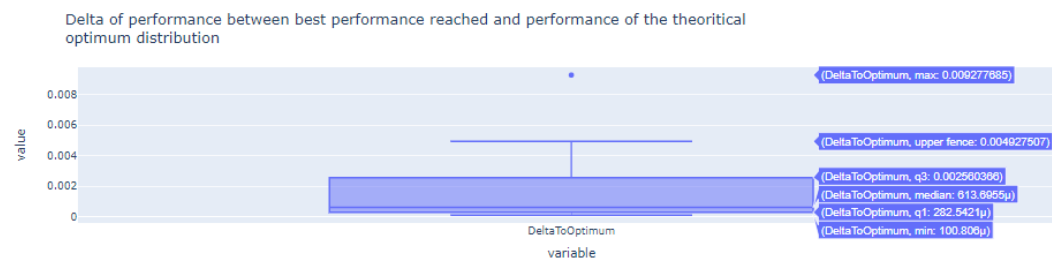

Figure 76: Distribution of the delta of performances reached by the swarm in comparison with the theoretical optimum solution with slightly decreasing  $w$ ,  $c_1$ ,  $c_2$ .

## E. Publications List

### **Identification of a Consensus in a Multicriteria Decision Process involving several Decision-Makers**

M.Carré, N.Nantier, S. Durieux, L. Piétrac

*Conference Paper at SESAR Innovation Days 2021, 2021*

### **Equity within Air Transportation Management: an Analysis of Equity index for Multi-Stakeholders Optimisation - Application to an airlines group operational use-case**

M.Carré, N.Nantier, S. Durieux, L. Piétrac

*Conference Paper Fourteenth US/Europe Air Traffic Management Research and Development Seminar (ATM2021), 2021*

### **User-Driven Prioritisation Process (UDPP) from advanced experimental to pre-operational validation environment**

N. Pilon, L. Guichard, Z. Bazso, G. Murgese, M. Carré

*Journal of Air Transport Management, 2021*

### **First Demonstration of the Impact of Airspace Users Priorities on the Network**

M. Carré, Y. De Wandeler, S. Stoyanov, J. Wobmann, M. Kettner.

*Research Workshop „Interdependencies within ATM Performance in the context of a dynamic environment”, 2020*

## F. Résumé de la Thèse

### Chapitre 1 : Introduction Générale et Contexte Industriel

Les opérations aériennes sont très complexes. Elles comportent de nombreuses règles spécifiques à chaque compagnie, intrinsèquement liées à leur marché et stratégie particuliers. Cela a très tôt attiré la communauté de recherche opérationnelle, notamment grâce à la création de l'AGIFORS (Airline Group of the International Federation of Operational Research Societies). Grâce aux avancées technologiques et scientifiques, la communauté de recherche opérationnelle continue à jouer un rôle important dans l'amélioration des opérations aériennes. Depuis une dizaine d'années, les compagnies aériennes s'intéressent à des outils d'aide à la gestion des opérations, et les premiers systèmes sont en cours d'implémentation.

Cette thèse est sponsorisée par Swiss International Air Lines, pour soutenir la recherche afin d'améliorer la stabilité, l'efficacité, l'impact environnemental des opérations, ainsi que la satisfaction de ses passagers. Cette thèse a pour but d'explorer un nouvel axe de recherche : l'optimisation conjointe des opérations de plusieurs compagnies aériennes. L'intérêt de SWISS est de réduire l'impact opérationnel de perturbations majeures, telles que des grèves du trafic aérien ou des phénomènes météorologiques (orages, neige, etc.). SWISS étant membre du groupe Lufthansa, la méthodologie est testée et validée sur un cas industriel du groupe Lufthansa.

La section 1.2 permet de poser les bases des opérations aériennes et de tous les processus en amont permettant un planning robuste (phase stratégique). La Figure 1 illustre le résumé des macro-processus ayant lieu lors de la phase stratégique pour permettre d'opérer un vol. Avant chaque saison, une négociation des heures d'arrivée et de départ pour chaque vol a lieu avec chaque aéroport concerné. Cela permet de proposer des nouveaux vols, d'adapter les temps de vol, dans le cas où de nouveaux avions plus rapides sont planifiés pour opérer ces vols, et de corriger certaines anomalies de la saison précédente (processus (1) sur la Figure 1). Un an avant le vol, les passagers peuvent effectuer leurs réservations sur un ou plusieurs vols opérés par la compagnie (processus (2) sur la Figure 1). Le planning des membres d'équipage est publié au maximum 1 mois avant le départ du vol. Chaque personnel d'équipage (cockpit ou cabine) est certifié sur des types d'avion particuliers. Certains aéroports nécessitent des qualifications particulières par exemple pour des approches à fortes pentes (processus (4) sur la Figure 1). Sept jours avant le jour des opérations, une immatriculation d'avion est affectée aux vols,



effectuant le passage d'affectation d'un avion « logique » (un type d'avion) à un avion « physique » (une immatriculation identifiant un avion particulier) (Processus (3) sur la Figure 1). Enfin, la gestion des opérations peut commencer le jour même des opérations (Processus (5) sur la Figure 1).

La section 1.3 permet d'expliciter plus en détails la phase tactique, qui débute quelques heures avant le vol jusqu'à son arrivée à l'aéroport prévu. Environ 12 heures avant le départ, le plan de vol le plus efficace est automatiquement calculé par un système dédié (en fonction des contraintes du trafic aérien et des prédictions météorologiques). Des Calculated Take Off Time (CTOT, l'heure exact de décollage calculée) sont attribués aux vols en fonction des restrictions des espaces aériens ou des aéroports (ayant une capacité limitée par rapport au nombre de vols quotidien en hausse). Cela impose en général du retard au départ des vols, ce qui peut avoir un effet boule de neige sur les vols suivants, à travers les connexions de passagers, celles des équipages, ou la rotation de l'avion. Les équipes d'experts opérationnels sont chargées de trouver des moyens d'atténuer l'impact de ces retards et perturbations. Si le retard propagé dans le réseau est trop important, une solution peut être d'annuler le vol, ou bien de changer d'avion et d'équipage les vols suivants. Les experts opérationnels doivent alors adapter les réservations des passagers sur des itinéraires alternatifs, appeler des équipages de réserve pour effectuer les vols impactés par les retards, ainsi que coordonner avec les stations (aéroports) les différentes actions à mettre en place.

De nombreuses perturbations dans les opérations ont lieu en Europe. Lors des quatre premiers mois de 2023, (EUROCONTROL, 2023) a signalé plus de 38 jours de grèves, dont 34 en France. Cela a impacté plus de 237,000 vols, affectant 10 millions de passagers et causant une annulation des voyages prévus pour environ 64,000 passagers par jour. Les paragraphes précédents montrent l'impact que peut causer une petite perturbation telle qu'un retard ou un membre d'équipage malade. Lors de perturbations majeures telles que des grèves ou des réductions de capacité aéroportuaires dues à du mauvais temps (i.e., orage ou neige), les outils d'optimisation et d'aide à la décision sont extrêmement importants. Ils permettent d'aider à trouver en un temps limité des solutions satisfaisantes pour l'ensemble des opérations et pour les passagers. Les combinaisons de retards et d'annulations, d'adaptations des réservations des passagers sont considérables. Une équipe d'experts peut difficilement rivaliser avec des outils d'optimisation intégrant bonnes données d'entrée et contraintes. C'est pour cela que la communauté de recherche opérationnelle a été et est toujours autant active sur ces sujets

d'optimisation, que ce soit l'optimisation du planning de vols, des passagers ou bien celle des équipages.

Pour des raisons stratégiques, financières, et opérationnelles, de nombreuses compagnies aériennes se sont regroupées en alliances ou groupe de compagnies. Cela leur permet d'étendre leur réseau d'aéroports desservis, ainsi que de réduire certains coûts pour faire face à la concurrence des compagnies aériennes low-cost. Certains groupes de compagnies aériennes n'harmonisent pas seulement les départements marketing, ventes et tarifications et maintenance, mais aussi les centres d'opérations. Dans ce cas, un seul centre d'opérations gère l'ensemble des vols de toutes les compagnies. Dans d'autres cas, tels que le groupe Air France - KLM et le groupe Lufthansa, les compagnies aériennes gardent leurs centres des opérations respectifs pour permettre une gestion au plus proche du marché local, de la stratégie et du positionnement de la compagnie aérienne. Une coordination relativement limitée a lieu dans la gestion des perturbations. Habituellement, les différents centres d'opérations s'informent à titre indicatif des vols qui seront annulés de leurs planning, et s'accordent sur une heure spécifique pour annuler les vols. En effet, avec l'outil d'adaptation des réservations, si les vols ne sont pas annulés en même temps, les passagers vont d'abord être transféré sur un vol d'une autre compagnie, qui potentiellement sera annulé quelques minutes plus tard, causant un nouveau transfert des passagers vers de nouveaux vols, etc.

L'originalité de cette thèse est de suggérer un nouveau paradigme : proposer à des compagnies aériennes d'optimiser conjointement leurs opérations au lieu d'optimiser indépendamment. Notre hypothèse est que cette optimisation conjointe est bénéfique pour l'ensemble des compagnies concernées lors d'une perturbation majeure. En effet, cela augmente considérablement l'espace des solutions et la probabilité qu'une meilleure solution soit trouvée. Cela soulève cependant de nombreuses questions, les opérations de chaque compagnie étant différentes, même au sein d'un même groupe. Quelles sont les variables de décision adéquates pour une optimisation de groupe ? Quelles contraintes et spécificités de chaque compagnie peut-on considérer, tout en respectant les contraintes de temps de calcul ? Comment évaluer si une solution est bonne dans le cas d'une vision de groupe ? Comment assurer que les compagnies aériennes acceptent une solution de groupe, qui pourrait être parfois à leurs dépens ? Et enfin, comment assurer qu'une optimisation de groupe amène non-seulement des bénéfices au niveau du groupe, mais respecte aussi une équité sur le long terme ?

Le chapitre 2 présente la revue de littérature effectuée sur les problèmes d'optimisation des opérations aériennes.

### **Chapitre 2 : Revue de littérature sur les Problèmes d'Optimisation des Opérations Aériennes**

La littérature présente trois grands axes de recherche : l'optimisation du planning de vols et des avions affectés, l'optimisation des passagers et l'optimisation des équipages. Ces trois axes peuvent être semi ou complètement intégrés les uns aux autres pour permettre une optimisation véritable des opérations aériennes. Effectivement, en cas de perturbation, les trois axes doivent être considérés pour proposer de bonnes solutions.

En ce qui concerne l'optimisation du planning de vol considérant les avions, de nombreuses méthodes sont proposées depuis la première proposée par (Teodorović and Guberinić, 1984). Des modélisations du problème grâce à des graphes permettent des résolutions efficaces grâce aux méthodes de générations de colonnes ((Bierlaire et al., 2007), (Liang et al., 2018)), des optimisations par colonies de fourmis (Sousa et al., 2015), des algorithmes génétiques ((Liu et al., 2008), (Liu et al., 2010)) ou même des méthodes d'apprentissage par renforcement prenant en compte certaines incertitudes ((Hondet et al., 2018), (Lee et al., 2022)). Au fur et à mesure des années, des problèmes de toujours plus grandes dimensions ont pu être solutionnés dans le temps de calcul imparti (de 2 à 5 minutes). Une revue de la littérature récente sur ce sujet est proposée par (Santana et al., 2023), et la Table 1 résume les différents articles importants. Tandis que les méthodes d'apprentissages semblent encore nécessiter des développements pour proposer une aide efficace et dans laquelle les experts puissent avoir confiance, les métaheuristiques présentent de nombreuses applications intéressantes sur ce problème d'optimisation.

En ce qui concerne l'optimisation du planning de vol intégrant l'optimisation des passagers, de nombreuses recherches ont découlées du défi du ROADEF en 2009 (société française de Recherche Opérationnelle et d'Aide à la Décision). Différents graphes ont été proposés, modélisant différemment les passagers et pour certains les vols, intégrant différemment les contraintes. Les méthodes de résolutions basées sur des recherches de larges voisinages (Bisaillon *et al.*, 2011), (Sinclair *et al.*, 2014)), des générations de colonnes ((Sinclair *et al.*, 2015), (Maher, 2015)) ou bien des heuristiques spécifiques et math-heuristiques ((Jozefowicz *et al.*, 2013), (Hu *et al.*, 2016), (Zhang *et al.*, 2016), (Naz Yetimoğlu and Selim Aktürk, 2021)) ont permis la prise en compte de différents aspects : des statuts spécifiques des passagers (VIP,

Première Classe, statuts de fidélité, etc.) à la prise en compte de l'incertitude que les passagers accepteront la solution proposée. Toutes ces approches sont itératives, proposant d'abord des annulations et retards puis optimisant les passagers sur ce nouveau planning. Certaines proposent une troisième étape adaptant des retards ou rajoutant des vols pour diminuer le nombre de passagers sans solution. Ces approches sont notamment intéressantes en combinant une métaheuristique pour l'optimisation des vols avec une modélisation du problème passagers en graphe. Une modélisation relativement simple, générique mais efficace consiste à utiliser des problèmes de flux « multi-commodity » ou bien de coûts minimum et flux maximum (Acuna-Agost *et al.*, 2015). La revue de littérature est résumée Table 2.

En ce qui concerne l'optimisation du planning de vol intégrant l'optimisation des équipages, différentes approches ont été proposées sur la base des générations de colonnes ((Guo, 2005), (Maher, 2016), (Parmentier and Meunier, 2020)) et de métaheuristicques tels que l'optimisation par essais particuliers ((Azadeh *et al.*, 2012)) ou des algorithmes génétiques ((Chang, 2012), (Aguiar *et al.*, 2011)). Les différences de modélisations des données, contraintes et règles sont hautement liées à la connaissance du milieu d'une compagnie aérienne particulière. En effet, les règles et contraintes sont spécifiques à chaque compagnie, son histoire et sa culture. Des règles générales telles que celles de l'EASA sont cependant communes à l'ensemble des modélisations des problèmes (plus ou moins en détails). La Table 3 résume les publications principales sur cet axe d'optimisation.

Ces deux premiers chapitres mènent à la conclusion préliminaire suivante : proposer une optimisation des équipages dans le contexte d'un groupe de compagnies aériennes seulement si les règles et contraintes sont harmonisées. Cela est pour l'instant inimaginable.

Quelques recherches ont été conduites au sujet de l'optimisation intégrée des trois axes (planning de vols, passagers et équipages, voir Table 4). Pour permettre une optimisation intégrée dans les temps de calcul impartis, il est important de choisir des simplifications judicieuses dans les contraintes et données à considérer. En ce qui concerne les opérations de plusieurs hubs (plusieurs aéroports principaux où les avions et équipages sont basés), les seules tentatives et publications concernent des compagnies qui sont gérées à partir d'un seul centre des opérations, et non de multiples centres opérationnels collaborant.

### **Chapitre 3 : Problématique, Verrous Scientifiques et Structure du Mémoire**

La problématique d'une optimisation conjointe de plusieurs compagnies aériennes pose de nombreux défis scientifiques, techniques, voire éthiques. Des limitations sont aussi à prendre

en compte pour une optimisation en un temps de calcul limité. Ainsi, comme discuté lors du chapitre 2, les équipages ne seront pas optimisés et nous proposerons dans cette thèse une optimisation semi-intégrée (planning et passagers). L'évaluation des solutions doit donc prendre en compte l'impact sur les équipages. Les étapes de la méthode de résolution proposée sont illustrées sur la Figure 4.

Pour l'optimisation du planning, une limitation est le changement d'avions pour opérer les vols. En effet, une compagnie n'est légalement pas autorisée à « prêter » un avion de sa flotte sans son équipage pour opérer le vol d'une autre compagnie sans accord préalable et unique. Afin de valider l'hypothèse qu'une optimisation de groupe peut être effectuée dans les délais impartis, nous proposons de nous limiter à l'attribution de retards et d'annulations, sans changements d'avions (étape S1 sur la Figure 4). Un verrou scientifique dans le cadre des optimisations passagers est de proposer une modélisation harmonisée : à la fois pour les différents statuts possibles des passagers, mais aussi pour les coûts d'adaptation des réservations et itinéraires passagers sur les vols du Lufthansa Group et les compagnies opérant en Code Share (vols d'autres compagnies). Cela correspond à l'étape S2 sur la Figure 4. À chaque fois que les optimisations planning et passagers proposent une solution, celle-ci doit être évaluée. Cependant, nous sommes dans le contexte d'un groupe, ce qui implique un alignement de tous les acteurs dans l'identification et la définition des indicateurs à prendre en compte, ainsi qu'une méthode claire, compréhensible et fiable. La définition des importances relatives de chacun des indicateurs doit être définie et acceptée par tous les acteurs (étape S3 sur la Figure 4). Le temps d'optimisation étant relativement court en comparaison du nombre de solutions à explorer, il est réaliste de supposer que l'optimiseur propose plusieurs solutions à la fin du temps de calcul imparti. C'est pour cela que les étapes de classement par chaque compagnie puis d'identification d'un consensus dans le groupe sont primordiales, doivent être claires, simples et utiliser des mécanismes compréhensibles par tous les utilisateurs. Cela correspond aux étapes S4 et S5 sur la Figure 4. Enfin, la problématique d'équité long-terme doit être abordée pour permettre un vrai optimum pour le groupe et non biaiser l'optimiseur avec des considérations d'équité strictes à chaque instances (étape S6 sur la Figure 4).

Les questions de recherches adjacentes sont donc :

**RQ 1 & 2 :** *Quels définitions et compromis dans les données et contraintes doivent être considérés pour une optimisation groupe efficace ?* Cela est traité dans les chapitres 4

(formalisation mathématiques), 8 (optimisation du planning de vols) et 9 (optimisation des flux passagers).

**RQ 3 :** *Comment proposer une méthode de décision multi-acteur ainsi que la définition d'indicateurs groupe, en respectant les spécificités de chaque compagnie, et leur objectifs commerciaux principaux ?* Cela est présenté dans le chapitre 5.

**RQ 4 &5 :** *Comment proposer un processus de classement des solutions par compagnie aérienne, puis – basé sur ces classements locaux – en identifier le compromis, tout en garantissant la confiance et l'acceptation des décideurs de chaque compagnie ?* Cela est présenté dans le chapitre 6.

**RQ 6 :** *Comment définir une équité globale sur le long terme et assurer que l'équité entre les acteurs soit obtenue sous certaines conditions ? Quels mécanismes de compensation interne au système d'optimisation groupe peuvent le garantir ?* Cela est présenté dans le chapitre 7.

#### **Chapitre 4 : Formalisation Mathématiques**

Ce chapitre présente tout d'abord le modèle Entité-Relation (

Figure 5), puis modélise mathématiquement les données d'entrée prises en compte dans une optimisation groupe, les variables de décisions, les contraintes, et enfin les indicateurs.

#### **Chapitre 5 : Approche Multicritères pour une décision de groupe**

Ce chapitre présente une revue de littérature des différentes méthodes multicritères, puis la méthode adaptée à notre problème. Une optimisation de groupe nécessite une méthode multi-acteur à la fois pour définir communément les indicateurs évaluant les solutions mais aussi pour définir une stratégie d'évaluation représentant la vision du groupe, et les importances relatives de chaque indicateur par rapport aux autres. Une revue de littérature est présentée sur les grandes méthodes de décisions multicritères. Celle-ci peut être approfondie grâce à celle de (Yannis *et al.*, 2020) sur les problèmes de transport, et celle de (Dožić, 2019) sur les méthodes multicritères utilisées dans l'aviation, y compris par les compagnies aériennes.

La méthode de TOPSIS (Technique for Order of Preference by Similarity to Ideal Solution, (Hwang and Yoon, 1981)) évalue chaque solution par rapport à une solution idéale « positive » et une solution idéale « négative ». En calculant la distance euclidienne pour chaque critère de la solution, il est possible de classer les solutions par similarité à la solution idéale « positive ».

Cependant, la distance Euclidienne ne considère pas les corrélations entre les différents indicateurs ni leurs relations d'importance, ce qui peut entraver la cohérence du jugement.

L'AHP (Analytic Hierarchy Process, (Saaty, 1982)) propose une hiérarchisation des indicateurs en groupes et sous-groupes, permettant de calculer des vecteurs de priorité entre des indicateurs appartenant à de mêmes (sous-) groupes. Les indicateurs doivent être indépendants. Les décideurs remplissent des matrices de comparaison grâce à l'échelle de Saaty (voir Table 6). L'utilisation de la moyenne géométrique (Saaty, 1989) permet d'obtenir une matrice de comparaison d'indicateurs deux à deux avec une vision groupe. Cette matrice est ensuite normalisée par colonne, chaque ligne est additionnée pour obtenir un vecteur, et le vecteur est normalisé. Ces vecteurs de priorité donnent les poids relatifs de chaque indicateur par rapport aux autres du même sous-groupe. L'AHP a l'avantage de présenter une structure claire, compréhensible, multi-acteurs et qui peut être facilement mise à jour en cas de besoin (i.e., changement de stratégie).

Les méthodes telles que PROMETHEE (Preference Ranking Organization Method for Enrichment Evaluation, (Brans and Vincke, 1985)) et ELECTRE (Elimination and Choice Expressing Reality, (Roy, 1991)) permettent de classer les solutions les unes par rapport aux autres. Cependant, elles utilisent des notions de pseudo-critères, quasi-critères, etc., qui peuvent porter à confusion des décideurs non familiers avec ces termes et concepts. De plus, l'utilisation de ces méthodes nécessitent un temps conséquent, que les décideurs opérationnels ne peuvent pas facilement allouer. La confiance des décideurs étant l'un des prérequis primordiaux pour un système groupe, les méthodes nécessitant trop d'explications et de temps de familiarisation ne sont pas adéquates

C'est pourquoi nous nous positionnons pour une AHP multi-acteur, présentée dans la section 5.2. L'arbre hiérarchisé des indicateurs est présenté Figure 12 et a été défini en étroite collaboration avec les experts opérationnels de différentes compagnies aériennes du groupe Lufthansa. Comme formalisé mathématiquement dans le chapitre 4, trois grandes familles d'indicateurs indépendants coexistent : les indicateurs opérationnels, passagers et équipages. Les indicateurs passagers sont séparés en deux sous-groupes, les passagers avec solution « coûteuse » (i.e., un retard engendrant une compensation financière ou un changement de classe) et les passagers sans solution le jour même. Ces deux sous-groupes comportent le même agencement de sous-indicateurs : les experts opérationnels considèrent les passagers selon des catégories en fonction de leur statuts (VIP, staff, etc.) et de leur classe (première, affaire,

premium économie et économie). Les indicateurs équipages permettent quatre évaluations indépendantes de l'impact d'une solution, et les indicateurs opérationnels permettent trois évaluations indépendantes de l'impact sur la suite des opérations. Une illustration de la méthode sur un cas d'utilisation réel est présentée dans la section 5.2.3.

## Chapitre 6 : Consensus Multi-Acteurs

Comme expliqué précédemment, le temps de calcul restreint et le grand nombre de combinaisons possibles amènent le cœur de l'optimisation à proposer plusieurs solutions aux représentants des compagnies aériennes. Certaines solutions peuvent impacter une compagnie plus que d'autres. Il est donc primordial de laisser les représentants définir activement leurs classements parmi ces solutions et ainsi participer au processus de consensus du groupe sur la solution à implémenter dans les opérations. Cependant, les solutions étant complexes et de nombreux indicateurs pouvant présenter des nuances différentes selon les solutions, il est nécessaire de proposer un support d'aide au classement pour les utilisateurs. Le choix de la solution consensus pour le groupe doit se faire selon une méthode claire, comprise et acceptée par tous les décideurs.

En plus des méthodes expliquées dans le chapitre 5, d'autres méthodes peuvent être intéressantes pour cette aide au classement. Les intégrales de Choquet (Choquet, 1954) et de Sugeno (Sugeno, 1974) sont intéressantes grâce à leur modélisation des incertitudes et des réponses partielles, cependant, elle requièrent un grand volume de données et comparaisons et sont souvent utilisées dans les suggestions utilisateurs sur les sites internet d'achats. La limite de temps acceptable pour les utilisateurs est de 2 minutes pour effectuer le classement. Ces méthodes ne peuvent donc pas être utilisées dans notre contexte. L'une des exigences est d'avoir une méthode claire, facilement compréhensible et fiable. La théorie du vote social présente des méthodes connues et généralement acceptées par tous. La méthode du choix de Condorcet (proposée au XVIII siècle) compte le nombre de fois où une solution est préférée aux autres. Les solutions peuvent ensuite être classées par ordre descendant de préférences. Cependant, certaines situations mènent à plusieurs solutions étant préférées autant de fois. La méthode du score de Borda est reconnue et utilisée notamment dans les compétitions sportives. Chaque candidat reçoit un nombre de points lié à son rang donné par chaque votant ( $N - rang$  points, avec  $N$  le nombre de solutions à classer). Cette méthode permet au décideur de donner des rangs égaux à des solutions équivalentes, et propose une solution représentant le consensus du groupe de votants.



Parmi les méthodes présentées, TOPSIS présente l'avantage qu'aucune participation de l'utilisateur n'est nécessaire. Cependant, lors des premiers mois d'utilisation du système, il est primordial de proposer aux utilisateurs de participer activement, afin qu'ils prennent confiance dans le système et la méthodologie de calcul. La méthode devant être facilement compréhensible, nécessitant une participation active mais limitée des utilisateurs, et enfin permettant un mécanisme de compensation (activité P5 de la Figure 10), la méthode des scores de Borda est choisie et adaptée à notre problème.

Premièrement, pour aider l'utilisateur dans son classement, chaque critère est considéré comme un votant, classant les solutions par rapport aux performances pour ce critère. Afin de mieux modéliser la décision humaine, il est proposé à l'utilisateur de définir un seuil d'indifférence (deux solutions ayant un delta de performance pour ce critère inférieur au seuil d'indifférence sont considérées équivalentes et classées au même rang) ainsi qu'un intervalle idéal de performance. En effet, dans certains cas opérationnels, une compagnie pourrait préférer annuler plus de vols que les autres compagnies du groupe, si son aéroport principal subit aussi une perturbation telle que de la neige ou des vents violents, provoquant une réduction des départs et arrivées possibles. Basé sur ces entrées utilisateurs, le classement de la compagnie est calculé via cette adaptation de la méthode des scores de Borda et présenté à l'utilisateur. Il est primordial que l'utilisateur puisse adapter si nécessaire le classement, en fonction des informations additionnelles qu'il peut avoir, ou d'une sensibilité différente que celle du Borda.

Lorsque tous les décideurs des compagnies participant à l'optimisation groupe ont validé leurs classements, une deuxième application de la méthode de Borda est effectuée, cette fois considérant chaque compagnie comme un votant. La solution remportant le plus de points est identifiée comme le consensus à implémenter.

Cette méthode de Borda en deux tours a fait l'objet d'une analyse de sensibilité et d'un article de conférence (Carré *et al.*, 2021a). Une hypothèse importante est que tous les décideurs sont supposés avoir un comportement rationnel, c'est-à-dire n'essayant pas d'influencer le résultat des votes. Cette hypothèse est justifiable par le fait que les compagnies appartiennent au même groupe, et que l'équité sur le long terme est surveillée et compensée en cas de déséquilibre (voir chapitre 7). L'analyse de sensibilité permet de bien illustrer le caractère de compromis que la méthode de Borda permet. En effet, cette méthode tend à essayer de diminuer le nombre de compagnies non-satisfaites (solution choisie étant classée dernière par ces compagnies), et

à apporter un niveau de satisfaction plus ou moins acceptable pour toutes les compagnies lors de situations très déséquilibrées.

### **Chapitre 7 : Approche Équité Long Terme**

Comme expliqué lors du chapitre 6, la supervision de l'équité sur le long terme est à la fois un garant du comportement rationnel des compagnies et de l'adhésion des compagnies à une solution groupe. Chaque instance peut proposer des solutions permettant une optimalité des résultats du groupe au détriment de certaines compagnies. Il est consciemment choisi de ne pas imposer une équité stricte entre les compagnies pour ne pas biaiser les performances groupe et ainsi réduire l'accès aux meilleures solutions pour les compagnies, leurs passagers et équipages.

L'équité est un sujet de recherche philosophique, politique et sociétale. De nombreux articles ont été publiés par rapport à l'iniquité face à la pauvreté ou bien celle de l'accès aux transports (Lewis *et al.*, 2021). Trois principaux indicateurs permettent de mesurer l'iniquité. Ces indicateurs doivent respecter des règles précises, rappelées par (Fourrey, 2019). L'indicateur de Gini (Gini, 1912) représente une approche strictement égalitaire. L'indicateur de Theil (Theil, 1967) permet de modéliser la sensibilité humaine du gain par rapport à la perte grâce au logarithme népérien. Enfin, l'indicateur de Atkinson (Atkinson, 1970) permet d'introduire un paramètre d'aversion à l'iniquité, qui influence les résultats de l'indicateur. Une analyse de sensibilité de ces indicateurs sur un cas d'étude simple de trois compagnies (Carré *et al.*, 2021b) a permis de mettre en lumière à la fois le besoin d'une définition multicritères de cet indicateur, ainsi que les comportements de chacun des indicateurs. Dans le cadre d'une optimisation et décision groupe, un indicateur d'équité doit remplir les exigences suivantes :

- Être calculable sur le long terme (plusieurs instances),
- Donner une mesure fiable de l'équité sur le long terme, décelant les compensations dans la durée,
- Permettre une décomposition par compagnie pour facilement identifier lesquelles sont négativement et positivement impactées par les décisions du groupe,
- Et enfin considérer la sensibilité de chaque compagnie par rapport aux différentes situations opérationnelles.

L'indicateur de Theil est le seul capable de modéliser à la fois cette sensibilité humaine et de décomposer clairement la « participation » de chaque compagnie dans le niveau d'iniquité. C'est pourquoi nos recherches se sont focalisées sur celui-ci.

Afin de permettre la sensibilité de chaque compagnie par rapport aux situations opérationnelles ainsi que de permettre de prendre tous les indicateurs en compte, le questionnaire AHP (présenté au chapitre 5 pour la décision multi-acteur) est dupliqué afin que les poids relatifs de chaque indicateur soient calculés à partir des réponses de chaque compagnie séparément. Ces questionnaires sont à remplir pour les trois situations opérationnelles suivantes : nominale (opérations standard), contraintes hub (l'aéroport majeur subit des perturbations provoquant une réduction de capacité) et contraintes équipages (peu de marge dans les plannings des équipages par rapport à leurs temps de vol maximum, et peu d'équipages de réserve).

L'un des intérêts de l'indicateur de Theil est de facilement pouvoir calculer l'apport dans l'iniquité de chaque compagnie. Cet apport doit prendre en compte l'historique des instances précédentes pour permettre un calcul de l'indicateur dans la durée. Trois méthodes ont été proposées : la moyenne des performances locales historiques, le calcul sur un horizon glissant et une baisse linéaire de l'impact des instances avec le temps. Après une analyse de ces trois méthodes et la présentation aux représentants de SWISS, il a été décidé d'utiliser l'horizon roulant avec une fenêtre correspondant à une saison opérationnelle (environ 40 instances).

À partir de cet indicateur global d'équité long terme, il est possible de traduire l'apport d'iniquité de chaque compagnie en un poids d'iniquité. Pour cela, l'opérateur SoftMax a été choisi, principalement connu dans les méthodes d'apprentissages tels les réseaux neuronaux (Cardarilli *et al.*, 2021). Cet opérateur provient de la distribution de Boltzmann utilisée en thermodynamique et en mécanique statique. Cela permet de transformer des performances de compagnie n'atteignant pas la moyenne des performances des compagnies sur l'historique, en un poids défini entre 0 et 1, correspondant à l'écart d'équité de cette compagnie par rapport au groupe. Ces poids sont dérivés pour chaque compagnie des « apports » d'iniquité calculés via l'indicateur de Theil, et influencent le deuxième round de Borda pour l'élicitation du compromis groupe (voir Figure 28). Ainsi, une compagnie, qui a été désavantagée sur la fenêtre d'horizon considérée par l'indicateur global long terme de Theil, aura un poids plus grand dans le classement de groupe et verra ses solutions préférées avoir plus de chance d'être choisie comme compromis.

Une analyse conduite sur ce mécanisme a prouvé l'efficacité de la méthode lors de situation légèrement déséquilibrées. Cependant, pour des situations très déséquilibrées (i.e., une compagnie annulant constamment les vols pour tout le groupe), ce mécanisme n'est pas suffisant pour rétablir l'équité sur le long terme. Cela suppose que les compagnies aient soit des stratégies et marchés très divergents (une optimisation groupe pourrait donc être remise en cause), soit que la méthode multicritère en elle-même doit être adaptée pour permettre des indicateurs prenant mieux en compte les aspects divergents.

### **Chapitre 8 : Optimisation du planning de vols**

Comme expliqué dans le chapitre 3, la première étape d'optimisation concerne le planning de vols, sans considération des changements d'avions. Cela consiste donc à trouver la meilleure combinaison d'annulation et de retards, maximisant la fonction d'évaluation multicritère définie dans le chapitre 5. Le chapitre 2 a mis en valeur l'efficacité des métaheuristiques pour ce problème d'optimisation. C'est pourquoi une revue de littérature des grandes métaheuristiques est proposée. Les méthodes d'optimisation à individus risquent de ne pas explorer suffisamment l'espace de recherche pour une optimisation groupe. Parmi les méthodes à population, plus efficaces dans la recherche parmi des grands espaces de recherche, les algorithmes évolutionnaires tels que les algorithmes génétiques (Goldberg and Holland, 1989), ont fait leurs preuves dans les problèmes d'affectation et de planning. Parmi les algorithmes par essais, les optimisations par colonies de fourmis (Coloni *et al.*, 1991) permettent de bonnes solutions pour les problèmes de planning modélisés par un graphe et ont déjà été proposées pour l'optimisation du planning de vols (Sousa *et al.*, 2015). Enfin, l'optimisation par essais particuliers (Kennedy and Eberhart, 1995) permet des optimisations à la fois dans le domaine continu et discret, et plusieurs adaptations fructueuses pour des problèmes d'affectation ont été publiées. Cependant, lors de la revue de littérature effectuée au chapitre 2, aucune approche proposant une optimisation des plannings de vols grâce à l'optimisation par essais particuliers n'a été proposée. C'est pourquoi il est intéressant d'utiliser cette métaheuristique, qui a aussi l'avantage d'être facilement explicable aux néophytes (exigence de méthodes claires, fiables et facilement compréhensibles).

Ainsi, les travaux sont focalisés sur une adaptation de l'optimisation par essaim particuliers dans le milieu discret. Le principe est relativement simple et basé sur les essaims d'oiseaux ou de poissons : un essaim de particules est initialisé au hasard dans l'espace de recherche. Chaque particule  $i$  possède une mémoire de la meilleure position visitée (celle qui a obtenu la meilleure

performance évaluée par la fonction de coûts, notée  $pbest_i^t$ ) et peut échanger des informations avec ses voisines pour connaître la position ayant atteint la meilleure performance parmi le voisinage (notée  $gbest_i^t$ ). Chaque voisinage est défini à l'initialisation, et certains chercheurs utilisent des voisinages dynamiques (i.e., recalculés à chaque itération). Chaque particule a une vitesse  $v_i^t$  qui peut être représentée comme un vecteur en plusieurs dimensions, ainsi qu'une position  $x_i^t$ . À chaque nouvelle itération  $t$ , la vitesse est mise à jour (voir Eq. 106, p.140). La vitesse est influencée par trois paramètres : l'inertie de la particule à continuer sur sa trajectoire, la tendance dite conservatrice à retourner vers la position  $pbest_i^t$ , et la tendance dite panurgienne à aller vers la meilleure position connue du voisinage  $gbest_i^t$ . La position  $x_i^t$  est enfin mise à jour selon l'équation Eq. 106 (p. 140).

Parmi la revue de littérature effectuée sur l'adaptation de cette métaheuristique pour les problématiques d'affectation et de planning, l'une d'entre elle apparaît très intéressante. (Izakian *et al.*, 2010) permet d'affecter des tâches à des machines de manière efficace tout en diminuant les étapes de calculs grâce à des mises à jour précises de la vitesse. L'adaptation de sa méthode à notre problème se révèle très intéressante dans la prise en compte de certaines contraintes dès l'initialisation, permettant de diminuer le temps de calcul nécessaire à chaque itération. La position est un vecteur de taille  $1 \times d$ , avec  $d$  le nombre de vols à replanifier (voir Table 21). Chaque vol peut être affecté à différents statuts de vols tels que « à l'heure », « avance de 5 minutes », « retard de 5 minutes », « retard de 10 minutes », etc. (voir Table 22). La vitesse de chaque particule est donc une matrice de taille  $m \times d$ , avec  $m$  le nombre de statuts de vols possibles (voir Table 23). Les valeurs de la matrice de vitesses sont initialisées au hasard entre des valeurs réelles  $[-V_{max}, V_{max}]$ . Pour chaque colonne (représentant un vol), la valeur la plus haute de la matrice donne le statut de vol auquel le vol sera affecté. La mise à jour des vitesses suit la même équation que celle de l'optimisation par essais particuliers pour le domaine continu. L'avantage de cette approche est d'initialiser les vitesses en fonction des contraintes. Par exemple, pour les vols qui ne peuvent pas partir avec plus de 30 minutes de retard dû à un couvre-feu dans l'aéroport d'arrivée, il suffit de ne pas initialiser les vitesses pour tous les éléments de la matrice correspondant aux statuts affectant plus de 30 minutes de retard pour ce vol particulier. Ainsi, les efforts de réparation des solutions après chaque itération sont minimisés, et moins de contraintes doivent être vérifiées.

La calibration des différents paramètres est présentée dans la section 8.2.3 et plus en détails dans l'annexe D. L'adaptation à notre problème d'optimisation du planning de vols multi-compagnie se révèle très performant.

### **Chapitre 9 : Optimisation des Flux de Passagers**

À chaque itération, l'optimisation par essaim particulaires propose un nouveau planning. Ce nouveau planning doit être évalué en termes de solutions passagers. Pour cela, deux méthodes ont été mises en place.

Tout d'abord, l'estimation d'une borne supérieure. En effet, le postulat était que les temps de calculs pour une optimisation des flux passagers seraient trop importants pour pouvoir être intégré à chaque itération pour chaque particule. Cette borne supérieure consiste à estimer le nombre de passagers ayant des solutions coûteuses ou aucune solution. La logique peut ainsi être expliquée : les passagers impactés par des retards ou des annulations sont agrégés en flux selon leurs aéroports d'origine, de destination et leur classe. Ces flux sont ordonnés par valeurs d'importance (en fonction du nombre de passagers dans le flux et de la classe). Chaque flux est alors considéré, les passagers sont affectés aux itinéraires disponibles, jusqu'à ce que plus aucune place dans les avions soient disponibles (voir pseudocode sur le Figure 45).

Une méthode d'optimisation fine a été développée, inspirée de la modélisation de (Acuna-Agost *et al.*, 2015). Les flux de passagers sont séparés en deux catégories : les flux entrants et les flux sortants de l'aéroport perturbé. Chaque catégorie est modélisée par un graphe dont les nœuds représentent les aéroports d'origine, de destination et les vols, tandis que les arcs représentent les connexions possibles entre les différents nœuds, avec des capacités et coûts particuliers. La section 9.2 décrit en détails la modélisation. Le problème est rapporté à un problème d'optimisation de coûts minimum et flux maximum. Le solveur de Google OR (open-source) est utilisé pour trouver une solution.

En développant et testant ces deux méthodes, les résultats sont plutôt surprenants par rapport au postulat : pour un temps de calcul quasiment équivalent (la méthode d'optimisation étant légèrement plus rapide que l'estimation de la borne supérieure), les résultats de la borne supérieure sont relativement bons pour les passagers avec solutions coûteuses dues à un changement de classe et pour les passagers sans solution. Cependant, lorsque les coûts de retard sont ajoutés à l'estimation de la borne supérieure, la qualité de l'estimation n'est plus satisfaisante. Après une optimisation du code des deux approches, l'optimisation fine des passagers a donc pu être intégrée directement avec l'optimisation du planning de vols,

permettant ainsi de trouver des solutions de qualité en respectant les contraintes de temps de calcul imposées.

### **Chapitre 10 : Application à un cas industriel : le Module d'Optimisation Globale**

Afin de pouvoir estimer les bénéfices d'une optimisation groupe, il est important de tester le système développé sur des données réelles. Cela a été effectué sur un jeu de donnée du 1<sup>er</sup> mai 2023, lors duquel les contrôleurs aériens français ont fait grève, causant une annulation obligatoire de 25 % des vols prévus à Paris Charles de Gaulle. L'ensemble des plannings de vols pour les compagnies aériennes du groupe Lufthansa a été récupéré avant la décision des experts opérationnels, ainsi que les données des passagers ayant un vol prévu de/vers l'aéroport perturbé. Cependant, les données des itinéraires alternatifs n'ont pu être récupérées que quelques mois plus tard pour des raisons techniques. Il est à noter que ces données sur les itinéraires passagers alternatifs ne sont pas complètes, et que seulement une petite partie des itinéraires existants a été extraite. De plus, le système de requête ne peut répondre qu'un maximum de 9 places sont disponibles dans un vol, même si plus de 9 sont vraiment disponibles (un seul chiffre autorisé dans la réponse de la requête). Pour les données équipages, seulement les données de SWISS ont pu être récupérées, dont la qualité était malheureusement insuffisante pour une intégration complète du calcul des indicateurs définis dans le chapitre 4. C'est pourquoi les résultats du système d'optimisation groupe ne peuvent pas être comparés aux données post-opérations.

De par les processus de décision au sein des différents centres d'opérations, les vols à annuler et retarder ne sont pas définis par rapport aux itinéraires alternatifs sur l'ensemble du groupe. C'est pourquoi il nous est possible d'effectuer une comparaison avec une réalité simulée. Cette réalité simulée est basée sur le planning des vols effectivement retardés et annulés par les experts opérationnels, sur lequel l'optimisation fine des passagers est lancée, avec les itinéraires alternatifs connus dans les données extraites. Cela permet d'analyser si les plannings de vols optimisés au niveau du groupe sont plus intéressants que les plannings choisis par les experts opérationnels de chaque compagnie indépendamment les unes des autres.

Une analyse sur 100 répliques de la même instance permet de montrer le bénéfice GOM (Module d'Optimisation Globale). 100% des solutions proposent un macro-indicateur meilleur que celui correspondant à la solution choisie par les experts. 90% des solutions permettent de proposer des solutions à 122 passagers supplémentaires. Pour les solutions trouvant moins de

solutions pour les passagers, cela impacte 33 passagers en moyenne. Enfin, l'impact sur les passagers de classe affaire est réduit (ce qui correspond à la fonction de coûts de l'optimisation fine, fournie par les experts). De plus, les indicateurs sur les équipages et l'impact opérationnel sont tous au maximum de leurs performances.

Ainsi, le GOM est capable de proposer des solutions très intéressantes pour le groupe de compagnies aériennes. Cela leur permet dans la plupart des cas de proposer des solutions à plus de passagers. Enfin, le GOM permet un vrai gain de temps pour les opérationnels. Pour effectuer une décision de retards et annulations, SWISS compte entre 4 à 5 heures, Lufthansa Munich entre 1 à 2 heures minimum. Le GOM assure un processus d'environ 15 minutes, de la définition de la perturbation dans le système, à la publication de la solution. Dû à l'assouplissement de certaines contraintes pour permettre une optimisation groupe, il est cependant à noter que les experts opérationnels de chaque compagnie doivent nécessairement vérifier l'impact sur leurs opérations et procéder aux ajustements locaux nécessaires (notamment liés aux équipages).

### **Conclusion Générale**

Cette thèse émet une hypothèse simple « l'union fait la force ». Lorsqu'une perturbation dans les opérations aériennes a lieu, perturbant plusieurs compagnies, chacune cherche une solution pour ses propres opérations, informant seulement les compagnies de son groupe de ses décisions. L'originalité de cette thèse réside dans le fait de changer le paradigme et de proposer une optimisation des opérations d'un groupe de compagnies aériennes souhaitant collaborer. Cela soulève de nombreuses questions scientifiques, techniques et éthiques (voir chapitre 1). Une revue de littérature des différents problèmes d'optimisation des opérations aériennes ont permis de mettre à jour des approches intéressantes, mais aussi de démontrer qu'aucune recherche n'avait été proposée pour l'instant sur ce sujet (chapitre 2). Le chapitre 3 propose la structure de la démarche, mets en lumière les verrous scientifiques et les questions de recherches qui en découlent.

**RQ 1 & 2 :** *Quels définitions et compromis dans les données et contraintes doivent être considérés pour une optimisation groupe efficace ?*

Un modèle mathématique a été proposée dans le chapitre 4 (formalisation mathématique), permettant d'identifier les données pouvant être obtenues de chaque compagnie aérienne, leurs définitions mathématiques, parfois simplifications, ainsi que l'écriture des contraintes auxquelles les variables de décision sont soumises. Basé sur ce modèle mathématique, le



chapitre 8 (optimisation du planning de vols) propose une adaptation de l'optimisation par essais particuliers pour notre problème et permet une résolution efficace du problème pour tous les vols du groupe de compagnies impactés par la perturbation. Intégrée dans cette optimisation, une méthode d'optimisation est proposée pour les flux de passagers impactés par des changements (retards et annulations) dans le planning. Chaque nouveau planning proposé par chaque particule de l'essai particulière est soumis à l'optimisation des flux passagers, modélisé comme un problème minimum coûts et maximum flux, résolu grâce à un solveur open-source. Cela est présenté dans le chapitre 9.

**RQ 3 :** *Comment proposer une méthode de décision multi-acteur ainsi que la définition d'indicateurs groupe, en respectant les spécificités de chaque compagnie, et leur objectifs commerciaux principaux ?*

Le chapitre 5 présente une adaptation de l'AHP multi-acteur. Les experts opérationnels de chaque compagnie ont été sollicités pour d'abord identifier les indicateurs importants pour une vision groupe, puis confirmer les définitions et enfin remplir les questionnaires permettant les comparaisons d'indicateurs deux à deux. Les poids de chaque indicateur pour une vision groupe ont pu être extraits et utilisés.

**RQ 4 & 5 :** *Comment proposer un processus de classement des solutions par compagnie aérienne, puis – basé sur ces classements locaux – en identifier le compromis, tout en garantissant la confiance et l'acceptation des décideurs de chaque compagnie ?*

Le chapitre 6 propose un processus permettant premièrement d'aider chaque expert opérationnel à classer les solutions (ce qui est – de l'opinion des experts – très difficile à juger sans support de calcul), et à la suite d'identifier la solution permettant le meilleur compromis pour le groupe. La méthode proposée devant être compréhensible, claire, et efficace, les théories du vote social présentent de nombreux avantages. Parmi ces différentes méthodes, la méthode de Borda a été choisie pour les deux processus. Le premier Borda considère chaque indicateur comme un votant. Les experts peuvent facilement exprimer leurs sensibilités humaines en adaptant des seuils d'indifférence et des intervalles idéaux de performance pour chaque indicateur. Le classement proposé par cette première application du Borda est vérifié, si nécessaire adapté, puis validé. Chaque compagnie est alors considérée comme un votant, et le compromis groupe est identifié grâce à l'application d'une deuxième méthode de Borda sur les classements.

**RQ 6 :** *Comment définir une équité globale sur le long terme et assurer que l'équité entre les acteurs soit obtenue sous certaines conditions ? Quels mécanismes de compensation interne au système d'optimisation groupe peuvent le garantir ?*

Le chapitre 7 permet de définir un indicateur d'équité à la fois global (prenant plusieurs indicateurs opérationnels en compte ainsi que la sensibilité des compagnies) et calculant l'équité sur la durée. Cet indicateur est basé sur l'indicateur de Gini. Des poids d'iniquités sont dérivés de cet indicateur d'équité global long-terme, grâce à l'opérateur SoftMax de Boltzmann. Cela permet d'influencer le deuxième round de Borda identifiant le consensus en faveur des compagnies aériennes les plus défavorisées par les instances du passé prises en compte.

Enfin, tous ces concepts et méthodes présentés ont été intégrés dans un prototype. Ce prototype a été testé sur une instance de données réelles pour permettre une quantification des bénéfices d'une optimisation groupe par rapport à une optimisation de chaque compagnie indépendamment. Les résultats montrent que le système d'optimisation groupe propose dans 100% des cas des solutions ayant une meilleure performance groupe que celle choisie par chaque compagnie indépendamment. Dans plus de 90% des cas, les solutions proposées permettent de trouver un itinéraire satisfaisant pour plus de passagers (en moyenne 122 passagers supplémentaires).

Le cas d'étude primaire de cette thèse est l'optimisation de groupe des opérations aériennes lors de perturbations. Cependant, cela ouvre de belles perspectives non seulement pour les compagnies aériennes mais aussi pour toutes les optimisations de groupe dans le monde du trafic aérien, notamment grâce aux processus de compromis proposés et surtout grâce au nouveau paradigme d'équité globale mesurée sur le long terme.

### **Perspectives**

Plusieurs perspectives découlent de ce travail. Au sujet de l'optimisation du planning des vols, l'optimisation par essais particuliers pourrait être adaptée pour proposer des changements d'avions pour les vols perturbés, en fonction des réserves de chaque compagnie aérienne. De plus, il a été démontré que l'optimisation par essais particuliers se révèle particulièrement efficace, mais cela pourrait être comparé avec les autres méthodes d'optimisation proposées pour des problèmes similaires.

Au sujet de l'optimisation des flux passagers, le modèle pourrait être amélioré, à la fois en permettant des coûts plus réalistes par rapport aux vrais coûts des billets en cas de changement de vol, mais aussi en permettant une granularité par compagnie si cela se révèle nécessaire dans le futur. De plus, intégrer l'incertitude qu'un passager accepte la solution proposée pourrait permettre d'obtenir des solutions bien plus personnelles et réalistes, permettant potentiellement à plus de passagers d'être pris en charge efficacement. Une intégration des transports multimodaux (tels que les lignes de trains à grande vitesse) est aussi un axe de recherche riche en potentiel.

En ce qui concerne les objectifs d'optimisation du groupe, plusieurs perspectives s'avèrent pertinentes. Compte-tenu des pressions sociétales et politiques par rapport à l'environnement, il serait intéressant de définir des indicateurs en lien avec les stratégies environnementales de la plupart des compagnies. De même, il serait intéressant d'intégrer les incertitudes liées à la fatigue des équipages dans les indicateurs, celle-ci pouvant provoquer des annulations de vols ou des diversions.

Au sujet du processus de consensus, la méthode du Borda a été choisie pour aider les experts à effectuer le classement grâce à sa simplicité d'explication et la transparence de ses calculs et résultats. Des méthodes plus évoluées pourraient être proposées, basées sur, par exemple, la méthode de TOPSIS ou bien l'intégration d'incertitudes grâce aux intégrales de Choquet ou Sugeno.

Enfin, il serait intéressant d'explorer de nouveaux mécanismes de compensation capables de compenser l'iniquité long terme de systèmes intrinsèquement déséquilibrés.

## G. Bibliography

---

- Abdelghany, K.F., Abdelghany, A.F. and Ekollu, G. (2008), “An integrated decision support tool for airlines schedule recovery during irregular operations”, *European Journal of Operational Research*, Vol. 185 No. 2, pp. 825–848, doi: 10.1016/j.ejor.2006.12.045.
- Acuna-Agost, R., Mancel, C., Boudia, M. and Jozefowicz, N. (2015), “A Passenger Recovery Approach for Airline Disruption Management”, *SSRN Electronic Journal*, doi: 10.2139/ssrn.2707676.
- Aguiar, B., Torres, J. and Castro, A.J.M. (2011), “Operational Problems Recovery in Airlines – A Specialized Methodologies Approach”, in Antunes, L. and Pinto, H.S. (Eds.), *Progress in Artificial Intelligence*, Vol. 7026, Springer Berlin Heidelberg, Berlin, Heidelberg, pp. 83–97, doi: 10.1007/978-3-642-24769-9\_7.
- Airlines for Europe. (2018), “Air Traffic Control (ATC) Strikes Are Destroying Air Traffic and Economies Across Europe”, Brussels.
- Alderighi, M. and Gaggero, A.A. (2018), “Flight cancellations and airline alliances: Empirical evidence from Europe”, *Transportation Research Part E: Logistics and Transportation Review*, Vol. 116, pp. 90–101, doi: 10.1016/j.tre.2018.05.008.
- Anderson, L.B. (1994), “Chapter 16 Voting theory”, *Handbooks in Operations Research and Management Science*, Vol. 6, Elsevier, pp. 561–584, doi: 10.1016/S0927-0507(05)80097-0.

- Ardil, C. (2022), “Fighter Aircraft Selection Using Neutrosophic Multiple Criteria Decision Making Analysis”, *World Academy of Science, Engineering and Technology International Journal of Computer and Systems Engineering*, Vol. 16 No. 1.
- Arıkan, U., Gürel, S. and Aktürk, M.S. (2016), “Integrated aircraft and passenger recovery with cruise time controllability”, *Annals of Operations Research*, Vol. 236 No. 2, pp. 295–317, doi: 10.1007/s10479-013-1424-2.
- Arıkan, U., Gürel, S. and Aktürk, M.S. (2017), “Flight Network-Based Approach for Integrated Airline Recovery with Cruise Speed Control”, *Transportation Science*, Vol. 51 No. 4, pp. 1259–1287, doi: 10.1287/trsc.2016.0716.
- Asadi, K. and Littman, M.L. (2017), “An Alternative Softmax Operator for Reinforcement Learning”, arXiv, 14 June.
- Atkinson, A.B. (1970), “On the measurement of inequality”, *Journal of Economic Theory*, Vol. 2 No. 3, pp. 244–263, doi: 10.1016/0022-0531(70)90039-6.
- Azadeh, A., Asadipour, G., Eivazy, H. and Shirkouhi, S.N. (2012), “A unique hybrid particle swarm optimisation algorithm for simulation and improvement of crew scheduling problem”, *International Journal of Operational Research*, Vol. 13 No. 4, p. 406, doi: 10.1504/IJOR.2012.046225.
- Baeck, T., Fogel, D.B. and Michalewicz, Z. (1997), *Handbook of Evolutionary Computation*, 1st Edition., CRC Press.
- Bangyal, W.H., Hameed, A., Alosaimi, W. and Alyami, H. (2021), “A New Initialization Approach in Particle Swarm Optimization for Global Optimization Problems”, edited by Dourado, A. *Computational Intelligence and Neuroscience*, Vol. 2021, pp. 1–17, doi: 10.1155/2021/6628889.

## Appendix G - Bibliography

- Barros, C.P. and Wanke, P. (2015), “An analysis of African airlines efficiency with two-stage TOPSIS and neural networks”, *Journal of Air Transport Management*, Vol. 44–45, pp. 90–102, doi: 10.1016/j.jairtraman.2015.03.002.
- Ben Ahmed, M., Hryhoryeva, M., Hvattum, L.M. and Haouari, M. (2022), “A matheuristic for the robust integrated airline fleet assignment, aircraft routing, and crew pairing problem”, *Computers & Operations Research*, Vol. 137, p. 105551, doi: 10.1016/j.cor.2021.105551.
- Bierlaire, M., Eggenberg, N. and Salani, M. (2007), “Column generation methods for disrupted airline schedules”, p. 17.
- Bisaillon, S., Cordeau, J.-F., Laporte, G. and Pasin, F. (2011), “A large neighbourhood search heuristic for the aircraft and passenger recovery problem”, *4OR*, Vol. 9 No. 2, pp. 139–157, doi: 10.1007/s10288-010-0145-5.
- Bouf, D. and Desmaris, C. (2015), “Spatial equity and high speed trains: the example of France”, *Sociology and Anthropology*, Vol. 8 No. 5, pp. 143–158, doi: 10.13189/sa.2020.080501.
- Brabant, Q., Couceiro, M., Dubois, D., Prade, H. and Rico, A. (2020), “Learning rule sets and Sugeno integrals for monotonic classification problems”, *Fuzzy Sets and Systems*, Vol. 401, pp. 4–37, doi: 10.1016/j.fss.2020.01.006.
- Brans, J.P. and Vincke, Ph. (1985), “Note—A Preference Ranking Organisation Method: (The PROMETHEE Method for Multiple Criteria Decision-Making)”, *Management Science*, Vol. 31 No. 6, pp. 647–656, doi: 10.1287/mnsc.31.6.647.
- Bratu, S. and Barnhart, C. (2006), “Flight operations recovery: New approaches considering passenger recovery”, *Journal of Scheduling*, Vol. 9 No. 3, pp. 279–298, doi: 10.1007/s10951-006-6781-0.

- Bridgman, P.W. (1922), *Dimensional Analysis*, New Haven, Connecticut, USA.
- Brucker, P., Qu, R. and Burke, E. (2011), “Personnel scheduling: Models and complexity”, *European Journal of Operational Research*, Vol. 210 No. 3, pp. 467–473, doi: 10.1016/j.ejor.2010.11.017.
- Bünnagel, U., Korte, B. and Vygen, J. (1998), “Efficient implementation of the Goldberg–Tarjan minimum-cost flow algorithm”, *Optimization Methods and Software*, Vol. 10 No. 2, pp. 157–174, doi: 10.1080/10556789808805709.
- Büyüközkan, G., Havle, C.A. and Feyzioğlu, O. (2021), “An integrated SWOT based fuzzy AHP and fuzzy MARCOS methodology for digital transformation strategy analysis in airline industry”, *Journal of Air Transport Management*, Vol. 97, p. 102142, doi: 10.1016/j.jairtraman.2021.102142.
- Cardarilli, G.C., Di Nunzio, L., Fazzolari, R., Giardino, D., Nannarelli, A., Re, M. and Spanò, S. (2021), “A pseudo-softmax function for hardware-based high speed image classification”, *Scientific Reports*, Vol. 11 No. 1, p. 15307, doi: 10.1038/s41598-021-94691-7.
- Carré, M., Nantier, E., Durieux, S. and Piétrac, L. (2021a), “Identification of a Consensus in a Multicriteria Decision Process involving several Decision-Makers”, *SESAR Innovation Days 2021*, presented at the SESAR Innovation Days 2021, virtual, p. 8.
- Carré, M., Nantier, E., Durieux, S. and Piétrac, L. (2021b), “Equity within Air Transportation Management – an Analysis of Inequity Index for Multi-Stakeholders Optimisation”, *ATM Seminar 2021*, p. 10.
- Castro, A.J.M. (2013), *A Distributed Approach to Integrated and Dynamic Disruption Management in Airline Operations Control*.

## Appendix G - Bibliography

- Castro, A.J.M. and Oliveira, E. (2007), “A DISTRIBUTED MULTI-AGENT SYSTEM TO SOLVE AIRLINE OPERATIONS PROBLEMS”:, *Proceedings of the Ninth International Conference on Enterprise Information Systems*, presented at the 9th International Conference on Enterprise Information Systems, SciTePress - Science and Technology Publications, Funchal, Madeira, Portugal, pp. 22–30, doi: 10.5220/0002404100220030.
- Castro, A.J.M. and Oliveira, E. (2009), “A Multi-Agent System for Airline Operations Control”, in Demazeau, Y., Pavón, J., Corchado, J.M. and Bajo, J. (Eds.), *7th International Conference on Practical Applications of Agents and Multi-Agent Systems (PAAMS 2009)*, Vol. 55, Springer Berlin Heidelberg, Berlin, Heidelberg, pp. 159–168, doi: 10.1007/978-3-642-00487-2\_17.
- Cavallaro, F., Bruzzone, F. and Nocera, S. (2020), “Spatial and social equity implications for High-Speed Railway lines in Northern Italy”, *Transportation Research Part A: Policy and Practice*, Vol. 135, pp. 327–340, doi: 10.1016/j.tra.2020.03.028.
- Chang, S.-C. (2012), “A duty based approach in solving the aircrew recovery problem”, *Journal of Air Transport Management*, Vol. 19, pp. 16–20, doi: 10.1016/j.jairtraman.2011.12.001.
- Chapman, A.J., McLellan, B.C. and Tezuka, T. (2018), “Prioritizing mitigation efforts considering co-benefits, equity and energy justice: Fossil fuel to renewable energy transition pathways”, *Applied Energy*, Vol. 219, pp. 187–198, doi: 10.1016/j.apenergy.2018.03.054.
- Chen, C.-H. and Chou, J.-H. (2017), “Multiobjective Optimization of Airline Crew Roster Recovery Problems Under Disruption Conditions”, *IEEE Transactions on Systems*,



- Man, and Cybernetics: Systems*, Vol. 47 No. 1, pp. 133–144, doi: 10.1109/TSMC.2016.2560130.
- Chen, R.-M. and Shih, H.-F. (2013), “Solving University Course Timetabling Problems Using Constriction Particle Swarm Optimization with Local Search”, *Algorithms*, Vol. 6 No. 2, pp. 227–244, doi: 10.3390/a6020227.
- Choquet, G. (1954), “Theory of capacities”, *Annales de l’institut Fourier*, Vol. 5, pp. 131–295, doi: 10.5802/aif.53.
- Clarke, M.D.D. (1998), *Development of Heuristic Procedures for Flight Rescheduling in the Aftermath of Irregular Airline Operations*, Massachusetts Institute of Technology, Boston.
- Clerc, M. (2003), “TRIBES. Un exemple d’optimisation par essaim particulaire sans parametres de contrôles”, *OEP’03*.
- Clerc, M. (2004), “Discrete Particle Swarm Optimization, illustrated by the Traveling Salesman Problem”, *New Optimization Techniques in Engineering*, Vol. 141, Springer Berlin Heidelberg, Berlin, Heidelberg, pp. 219–239, doi: 10.1007/978-3-540-39930-8\_8.
- Coello Coello, C.A. and Reyes-Sierra, M. (2006), “Multi-Objective Particle Swarm Optimizers: A Survey of the State-of-the-Art”, *International Journal of Computational Intelligence Research*, Vol. 2 No. 3, doi: 10.5019/j.ijcir.2006.68.
- Coloni, A., Dorigo, M. and Maniezzo, V. (1991), “Distributed Optimization by Ant Colonies”, *European Conference on Artificial Life*, Paris, France.
- Cook, A. (2015), *The Cost of Passenger Delay to Airlines in Europe*, University of Westminster.

## Appendix G - Bibliography

- Cook, A., Tanner, G. and Bolic, T. (2021), *Industry Briefing on Updates to the European Cost of Delay*, No. BEACON-D3.2, University of Westminster, p. 39.
- Cook, A., Tanner, G. and Lawes, A. (2012), “The hidden cost of airline unpunctuality”, *Journal of Transport Economics and Policy*, Vol. 46, pp. 157–73.
- Cooren, Y., Clerc, M. and Siarry, P. (2009), “Performance evaluation of TRIBES, an adaptive particle swarm optimization algorithm”, *Swarm Intelligence*, Vol. 3 No. 2, pp. 149–178, doi: 10.1007/s11721-009-0026-8.
- Corrente, S., Greco, S. and Ishizaka, A. (2016), “Combining analytical hierarchy process and Choquet integral within non-additive robust ordinal regression”, *Omega*, Vol. 61, pp. 2–18, doi: 10.1016/j.omega.2015.07.003.
- De Maio, F.G. (2007), “Income inequality measures”, *Journal of Epidemiology & Community Health*, Vol. 61 No. 10, pp. 849–852, doi: 10.1136/jech.2006.052969.
- Delgado, L., Gurtner, G., Mazzarisi, P., Zaoli, S., Valput, D., Cook, A. and Lillo, F. (2021), “Network-wide assessment of ATM mechanisms using an agent-based model”, *Journal of Air Transport Management*, Vol. 95, p. 102108, doi: 10.1016/j.jairtraman.2021.102108.
- Deng, G.-F. and Lin, W.-T. (2011), “Ant colony optimization-based algorithm for airline crew scheduling problem”, *Expert Systems with Applications*, Vol. 38 No. 5, pp. 5787–5793, doi: 10.1016/j.eswa.2010.10.053.
- Deroussi, L. (2016), *Metaheuristics for Logistics*, ISTE Ltd ; John Wiley & Sons Inc, London [England] : Hoboken, NJ.
- Dixit, M. and Sivakumar, A. (2020), “Capturing the impact of individual characteristics on transport accessibility and equity analysis”, *Transportation Research Part D: Transport and Environment*, Vol. 87, p. 102473, doi: 10.1016/j.trd.2020.102473.

- Dorigo, M. and Blum, C. (2005), “Ant colony optimization theory: A survey”, *Theoretical Computer Science*, Vol. 344 No. 2–3, pp. 243–278, doi: 10.1016/j.tcs.2005.05.020.
- Dožić, S. (2019), “Multi-criteria decision making methods: Application in the aviation industry”, *Journal of Air Transport Management*, Vol. 79, p. 101683, doi: 10.1016/j.jairtraman.2019.101683.
- Du, Y., Lin, X., Pan, Y., Chen, Z., Xia, H. and Luo, Q. (2023), “Identifying influential airports in airline network based on failure risk factors with TOPSIS”, *Chaos, Solitons & Fractals*, Vol. 169, p. 113310, doi: 10.1016/j.chaos.2023.113310.
- Dubois, D., Prade, H. and Rico, A. (2014), “The logical encoding of Sugeno integrals”, *Fuzzy Sets and Systems*, Vol. 241, pp. 61–75, doi: 10.1016/j.fss.2013.12.014.
- EASA. (2023), “Type-Certificate Data Sheet BD-500 No: EASA.IM.A.570”.
- El Dor, A., Lemoine, D., Clerc, M., Siarry, P., Deroussi, L. and Gourgand, M. (2015), “Dynamic cluster in particle swarm optimization algorithm”, *Natural Computing*, Vol. 14 No. 4, pp. 655–672, doi: 10.1007/s11047-014-9465-2.
- Engelhardt, L., Lopez Del Puerto, M. and Chonacky, N. (2015), “Simple and synergistic ways to understand the Boltzmann distribution function”, *American Journal of Physics*, Vol. 83 No. 9, pp. 787–793, doi: 10.1119/1.4923204.
- EUROCONTROL. (2022a), *EUROCONTROL Aviation Outlook 2050*, EUROCONTROL.
- EUROCONTROL. (2022b), *EUROCONTROL CODA Digest Annual Report 2022*, EUROCONTROL.
- EUROCONTROL. (2023), *EUROCONTROL Aviation Trends - Impact of Strikes on European Aviation*, EUROCONTROL.
- EUROCONTROL, Sfyroeras, M. and Vega, V. (2023), “ATFCM Users Manual”,.

## Appendix G - Bibliography

- European Commission, Directorate General for Research and Innovation and Directorate General for Mobility and Transport. (2011), *Flightpath 2050 :Europe's Vision for Aviation : Maintaining Global Leadership and Serving Society's Needs.*, Publications Office, LU.
- European Parliament. (2004), "Regulation (EC) No 261/2004 of the European Parliament and of the Council of 11 February 2004 establishing common rules on compensation and assistance to passengers in the event of denied boarding and of cancellation or long delay of flights, and repealing Regulation (EEC) No 295/91 (Text with EEA relevance) - Commission Statement Official Journal L 046 , 17/02/2004 P. 0001 – 0008".
- Ezugwu, A.E., Shukla, A.K., Nath, R., Akinyelu, A.A., Agushaka, J.O., Chiroma, H. and Muhuri, P.K. (2021), "Metaheuristics: a comprehensive overview and classification along with bibliometric analysis", *Artificial Intelligence Review*, Vol. 54 No. 6, pp. 4237–4316, doi: 10.1007/s10462-020-09952-0.
- Fourrey, K. (2019), *Décomposition des indices d'inégalité et impact des politiques publiques*, Thesis. Economies et finances, Normandie Université, November.
- Gad, A.G. (2022), "Particle Swarm Optimization Algorithm and Its Applications: A Systematic Review", *Archives of Computational Methods in Engineering*, Vol. 29 No. 5, pp. 2531–2561, doi: 10.1007/s11831-021-09694-4.
- Gao, C. (2007), *Airline Integrated Planning and Operations*, Georgia Institute of Technology, Atlanta.
- Garg, C.P. (2016), "A robust hybrid decision model for evaluation and selection of the strategic alliance partner in the airline industry", *Journal of Air Transport Management*, Vol. 52, pp. 55–66, doi: 10.1016/j.jairtraman.2015.12.009.

- Gini, C. (1912), *Variabilità e Mutuabilità. Contributo Allo Studio Delle Distribuzioni e Delle Relazioni Statistiche (Variability and Mutability, Contribution to the Study of Statistical Distributions and Relations)*, Studi Economico-Giuridici della R. Cagliari: Università di Cagliari.
- Glover, F. (1989), “Tabu Search - Part I”, *ORSA Journal on Computing*, Vol. 1 No. 3.
- Goldberg, A.V. (1997), “An Efficient Implementation of a Scaling Minimum-Cost Flow Algorithm”, *Journal of Algorithms*, Vol. 22 No. 1, pp. 1–29, doi: 10.1006/jagm.1995.0805.
- Goldberg, D.E. and Holland, J.H. (1989), *Genetic Algorithms and Machine Learning*, Addison Wesley.
- Gu, W., Saaty, T.L. and Wei, L. (2018), “Evaluating and Optimizing Technological Innovation Efficiency of Industrial Enterprises Based on Both Data and Judgments”, *International Journal of Information Technology & Decision Making*, Vol. 17 No. 01, pp. 9–43, doi: 10.1142/S0219622017500390.
- Guo, Y. (2005), *Decision Support Systems for Airline Crew Recovery*, Faculty of Business Administration, Economics and Business Computing University of Paderborn, Paderborn.
- Haddad, M., Sanders, D. and Tewkesbury, G. (2020), “Selecting a discrete multiple criteria decision making method for Boeing to rank four global market regions”, *Transportation Research Part A: Policy and Practice*, Vol. 134, pp. 1–15, doi: 10.1016/j.tra.2020.01.026.
- Hamidah, M., Mohd Hasmadi, I., Chua, L.S.L., Yong, W.S.Y., Lau, K.H., Faridah-Hanum, I. and Pakhriazad, H.Z. (2022), “Development of a protocol for Malaysian Important Plant Areas criterion weights using Multi-criteria Decision Making - Analytical

## Appendix G - Bibliography

- Hierarchy Process (MCDM-AHP)", *Global Ecology and Conservation*, Vol. 34, p. e02033, doi: 10.1016/j.gecco.2022.e02033.
- Hananel, R. and Berechman, J. (2016), "Justice and transportation decision-making: The capabilities approach", *Transport Policy*, Vol. 49, pp. 78–85, doi: 10.1016/j.tranpol.2016.04.005.
- Hassan, L.K., Santos, B.F. and Vink, J. (2021), "Airline disruption management: A literature review and practical challenges", *Computers & Operations Research*, Vol. 127, p. 105137, doi: 10.1016/j.cor.2020.105137.
- Heger, S. (2018), *Entwicklung Und Einsatz Eines Entscheidungsunterstützungssystems in Der Verkehrszentrale Einer Fluggesellschaft*, PhD Thesis, Darmstadt.
- Herrero, C. and Villar, A. (2021), "Group decisions from individual rankings: The Borda–Condorcet rule", *European Journal of Operational Research*, Vol. 291 No. 2, pp. 757–765, doi: 10.1016/j.ejor.2020.09.043.
- Hondet, G., Delgado, L. and Gurtner, G. (2018), "Airline Disruption Management with Aircraft Swapping and Reinforcement Learning", p. 21.
- Hsu, C.-C. and Liou, J.J.H. (2013), "An outsourcing provider decision model for the airline industry", *Journal of Air Transport Management*, Vol. 28, pp. 40–46, doi: 10.1016/j.jairtraman.2012.12.009.
- Hu, Y., Liao, H., Zhang, S. and Song, Y. (2017), "Multiple objective solution approaches for aircraft rerouting under the disruption of multi-aircraft", *Expert Systems with Applications*, Vol. 83, pp. 283–299, doi: 10.1016/j.eswa.2017.04.031.
- Hu, Y., Song, Y., Zhao, K. and Xu, B. (2016), "Integrated recovery of aircraft and passengers after airline operation disruption based on a GRASP algorithm", *Transportation*

- Research Part E: Logistics and Transportation Review*, Vol. 87, pp. 97–112, doi: 10.1016/j.tre.2016.01.002.
- Hu, Y., Zhang, P., Fan, B., Zhang, S. and Song, J. (2021), “Integrated recovery of aircraft and passengers with passengers’ willingness under various itinerary disruption situations”, *Computers & Industrial Engineering*, Vol. 161, p. 107664, doi: 10.1016/j.cie.2021.107664.
- Hwang, CL. and Yoon, K. (1981), “Methods for Multiple Attribute Decision Making.”, *Multiple Attribute Decision Making. Lecture Notes in Economics and Mathematical Systems*, Vol. 186, Springer Berlin Heidelberg.
- Imran Hossain, Sk., Akhand, M.A.H., Shuvo, M.I.R., Siddique, N. and Adeli, H. (2019), “Optimization of University Course Scheduling Problem using Particle Swarm Optimization with Selective Search”, *Expert Systems with Applications*, Vol. 127, pp. 9–24, doi: 10.1016/j.eswa.2019.02.026.
- Ishizaka, A. and Siraj, S. (2018), “Are multi-criteria decision-making tools useful? An experimental comparative study of three methods”, *European Journal of Operational Research*, Vol. 264 No. 2, pp. 462–471, doi: <https://doi.org/10.1016/j.ejor.2017.05.041>.
- Izakian, H., Ladani, B.T., Abraham, A. and Snásel, V. (2010), “A Discrete Particle Swarm Optimization Approach for Grid Job Scheduling”, Vol. 6 No. *International Journal of Innovative Computing, Information and Control*, p. 15.
- Jozefowicz, N., Mancel, C. and Mora-Camino, F. (2013), “A heuristic approach based on shortest path problems for integrated flight, aircraft, and passenger rescheduling under disruptions”, *Journal of the Operational Research Society*, Vol. 64 No. 3, pp. 384–395, doi: 10.1057/jors.2012.20.

## Appendix G - Bibliography

- Kahneman, D. and Tversky, A. (1979), “Prospect Theory: An Analysis of Decision under Risk”, *Econometrica*, Vol. 47 No. 2, p. 263, doi: 10.2307/1914185.
- Karaman, A.S. and Akman, E. (2018), “Taking-off corporate social responsibility programs: An AHP application in airline industry”, *Journal of Air Transport Management*, Vol. 68, pp. 187–197, doi: 10.1016/j.jairtraman.2017.06.012.
- Karunya, N. and Deepa, D.T. (2022), “Comparative Performance Analysis of Task Scheduling In Cloud Computing Using ACO, PSO, Firefly And Loa Algorithms”, *JOURNAL OF ALGEBRAIC STATISTICS*, Vol. 13 No. 3, p. 12.
- Kennedy, J. and Eberhart, R. (1995), “Particle Swarm Optimization”, *Proceedings of the IEEE International Conference on Neural Networks IV*, pp. 1942–1948.
- Kennedy, J. and Eberhart, R.C. (1997), “A discrete binary version of the particle swarm algorithm”, *1997 IEEE International Conference on Systems, Man, and Cybernetics. Computational Cybernetics and Simulation*, Vol. 5, presented at the 1997 IEEE International Conference on Systems, Man, and Cybernetics. Computational Cybernetics and Simulation, IEEE, Orlando, FL, USA, pp. 4104–4108, doi: 10.1109/ICSMC.1997.637339.
- Kilic, H.S., Zaim, S. and Delen, D. (2014), “Development of a hybrid methodology for ERP system selection: The case of Turkish Airlines”, *Decision Support Systems*, Vol. 66, pp. 82–92, doi: 10.1016/j.dss.2014.06.011.
- Kiraci, K. and Akan, E. (2020), “Aircraft selection by applying AHP and TOPSIS in interval type-2 fuzzy sets”, *Journal of Air Transport Management*, Vol. 89, p. 101924, doi: 10.1016/j.jairtraman.2020.101924.
- Kirkpatrick, S., Gelatt, C.D. and Vecchi, M.P. (1983), “Optimization by Simulated Annealing”, *Science*, Vol. 220 No. 4598, pp. 671–680, doi: 10.1126/science.220.4598.671.



- Knapp, M.A. (1902), “Social Effects of Transportation”, *The ANNALS of the American Academy of Political and Social Science*, Vol. 20 No. 1, pp. 1–15, doi: 10.1177/000271620202000101.
- Kohl, N., Larsen, A., Larsen, J., Ross, A. and Tiourine, S. (2007), “Airline disruption management—Perspectives, experiences and outlook”, *Journal of Air Transport Management*, Vol. 13 No. 3, pp. 149–162, doi: 10.1016/j.jairtraman.2007.01.001.
- Kumar, A., Sah, B., Singh, A.R., Deng, Y., He, X., Kumar, P. and Bansal, R.C. (2017), “A review of multi criteria decision making (MCDM) towards sustainable renewable energy development”, *Renewable and Sustainable Energy Reviews*, Vol. 69, pp. 596–609, doi: 10.1016/j.rser.2016.11.191.
- Lee, J., Lee, K. and Moon, I. (2022), “A reinforcement learning approach for multi-fleet aircraft recovery under airline disruption”, *Applied Soft Computing*, Vol. 129, p. 109556, doi: 10.1016/j.asoc.2022.109556.
- Letovsky, L. (1997), *Airline Operations Recovery*, School of Industrial and Systems Engineering, Georgia Institute of Technology, Atlanta.
- Lewis, E.O., MacKenzie, D. and Kaminsky, J. (2021), “Exploring equity: How equity norms have been applied implicitly and explicitly in transportation research and practice”, *Transportation Research Interdisciplinary Perspectives*, Vol. 9, p. 100332, doi: 10.1016/j.trip.2021.100332.
- Liang, Z., Xiao, F., Qian, X., Zhou, L., Jin, X., Lu, X. and Karichery, S. (2018), “A column generation-based heuristic for aircraft recovery problem with airport capacity constraints and maintenance flexibility”, *Transportation Research Part B: Methodological*, Vol. 113, pp. 70–90, doi: 10.1016/j.trb.2018.05.007.

## Appendix G - Bibliography

- Liu, Q., Zhang, X., Chen, X. and Chen, X. (2013), “Interfleet and Intrafleet Models for Crew Recovery Problems”, *Transportation Research Record: Journal of the Transportation Research Board*, Vol. 2336 No. 1, pp. 75–82, doi: 10.3141/2336-09.
- Liu, T.-K., Chen, C.-H. and Chou, J.-H. (2010), “Optimization of short-haul aircraft schedule recovery problems using a hybrid multiobjective genetic algorithm”, *Expert Systems with Applications*, Vol. 37 No. 3, pp. 2307–2315, doi: 10.1016/j.eswa.2009.07.068.
- Liu, T.-K., Jeng, C.-R. and Chang, Y.-H. (2008), “Disruption Management of an Inequality-Based Multi-Fleet Airline Schedule by a Multi-Objective Genetic Algorithm”, *Transportation Planning and Technology*, Vol. 31 No. 6, pp. 613–639, doi: 10.1080/03081060802492652.
- Liu, Z., Zhao, Y. and Liu, P. (2023), “An integrated FMEA framework considering expert reliability for classification and its application in aircraft power supply system”, *Engineering Applications of Artificial Intelligence*, Vol. 123, p. 106319, doi: 10.1016/j.engappai.2023.106319.
- Lourenço, H., Martin, O. and Stützle, T. (2003), “Iterated Local Search”, in Glover, F. and Kochenberger, G. (Eds.), *Handbook of Metaheuristics*, Kluwer Academic Publishers, Boston.
- Maher, S.J. (2015), “A novel passenger recovery approach for the integrated airline recovery problem”, *Computers & Operations Research*, Vol. 57, pp. 123–137, doi: 10.1016/j.cor.2014.11.005.
- Maher, S.J. (2016), “Solving the Integrated Airline Recovery Problem Using Column-and-Row Generation”, *Transportation Science*, Vol. 50 No. 1, pp. 216–239, doi: 10.1287/trsc.2014.0552.

- Mapetu, J.P.B., Chen, Z. and Kong, L. (2019), “Low-time complexity and low-cost binary particle swarm optimization algorithm for task scheduling and load balancing in cloud computing”, *Applied Intelligence*, Vol. 49 No. 9, pp. 3308–3330, doi: 10.1007/s10489-019-01448-x.
- Martens, K. (2016), *Transport Justice. Designing Fair Transportation Systems*, New York, NY: Routledge, 2016.
- Mathaisel, D.F.X. (1996), “Decision support for airline system operations control and irregular operations”, *Computers & Operations Research*, Vol. 23 No. 11, pp. 1083–1098, doi: 10.1016/0305-0548(96)00007-X.
- Medard, C.P. and Sawhney, N. (2007), “Airline crew scheduling from planning to operations”, *European Journal of Operational Research*, Vol. 183 No. 3, pp. 1013–1027, doi: 10.1016/j.ejor.2005.12.046.
- Meng, F., Chen, S.-M. and Tang, J. (2021), “Multicriteria decision making based on bi-direction Choquet integrals”, *Information Sciences*, Vol. 555, pp. 339–356, doi: 10.1016/j.ins.2020.10.055.
- Merkert, R. and Morrell, P.S. (2012), “Mergers and acquisitions in aviation – Management and economic perspectives on the size of airlines”, *Transportation Research Part E: Logistics and Transportation Review*, Vol. 48 No. 4, pp. 853–862, doi: 10.1016/j.tre.2012.02.002.
- Misran, M.F.R., Roslin, E.N. and Mohd Nur, N. (2020), “AHP-Consensus Judgement on Transitional Decision-Making: With a Discussion on the Relation towards Open Innovation”, *Journal of Open Innovation: Technology, Market, and Complexity*, Vol. 6 No. 3, p. 63, doi: 10.3390/joitmc6030063.

## Appendix G - Bibliography

- Mocholi, david. (2022), *BEACON D4.2-Final-Model-Results-V.01.00.00.Pdf*, No. D4.2, University of Westminster.
- Morales-Hernández, A., Van Nieuwenhuysse, I. and Gonzalez, S.R. (2022), “A survey on multi-objective hyperparameter optimization algorithms for Machine Learning”, arXiv, 15 November.
- Narodytska, N. and Walsh, T. (2014), “The Computational Impact of Partial Votes on Strategic Voting”, *21st European Conference on Artificial Intelligence*, Prague.
- Naz Yetimoğlu, Y. and Selim Aktürk, M. (2021), “Aircraft and passenger recovery during an aircraft’s unexpected unavailability”, *Journal of Air Transport Management*, Vol. 91, p. 101991, doi: 10.1016/j.jairtraman.2020.101991.
- Niehaus, M., Galilea, P. and Hurtubia, R. (2016), “Accessibility and equity: An approach for wider transport project assessment in Chile”, *Research in Transportation Economics*, Vol. 59, pp. 412–422, doi: 10.1016/j.retrec.2016.05.003.
- Nissen, R. and Haase, K. (2006), “Duty-period-based network model for crew rescheduling in European airlines”, *Journal of Scheduling*, Vol. 9 No. 3, pp. 255–278, doi: 10.1007/s10951-006-6780-1.
- Ogunsina, K.E., Davendralingam, N., Billionis, I. and DeLaurentis, D.A. (2019), “Dimensionality Reduction in a Data-Driven Model for Airline Disruption Management”, *AIAA Scitech 2019 Forum*, presented at the AIAA Scitech 2019 Forum, American Institute of Aeronautics and Astronautics, San Diego, California, doi: 10.2514/6.2019-0403.
- Omoeva, C., Cunha, N. and Moussa, W. (2019), “Measuring Equity of Education Resource Allocation: An Output-Based Approach”, Unpublished, doi: 10.13140/RG.2.2.26440.47360.

- Park, N.K. and Cho, D.-S. (1997), “The effect of strategic alliance on performance”, *Journal of Air Transport Management*, Vol. 3 No. 3, pp. 155–164, doi: 10.1016/S0969-6997(97)00026-4.
- Parmentier, A. and Meunier, F. (2020), “Aircraft routing and crew pairing: Updated algorithms at Air France”, *Omega*, Vol. 93, p. 102073, doi: 10.1016/j.omega.2019.05.009.
- Pels, E. (2021), “Optimality of the hub-spoke system: A review of the literature, and directions for future research”, *Transport Policy*, Vol. 104, pp. A1–A10, doi: 10.1016/j.tranpol.2020.08.002.
- Performance Review Commission. (2020), *Performance Review Report, An Assessment of Air Traffic Management in Europe during the Calendar Year 2019*.
- Petersen, J.D., Sölveling, G., Clarke, J.-P., Johnson, E.L. and Shebalov, S. (2012), “An Optimization Approach to Airline Integrated Recovery”, *Transportation Science*, Vol. 46 No. 4, pp. 482–500, doi: 10.1287/trsc.1120.0414.
- Pilon, N., Cook, A., Ruiz, S., Bujor, A. and Castelli, L. (2016), “Improved Flexibility and Equity for Airspace Users During Demand-capacity Imbalance”, p. 9.
- Pilon, N., Guichard, L., Bazso, Z., Murgese, G. and Carré, M. (2021), “User-Driven Prioritisation Process (UDPP) from advanced experimental to pre-operational validation environment”, *Journal of Air Transport Management*, Vol. 97, doi: 10.1016/j.jairtraman.2021.102124.
- Price, L.L. and Rowntree, B.S. (1902), “Poverty: A Study of Town Life.”, *The Economic Journal*, Vol. 12 No. 45, p. 56, doi: 10.2307/2957025.
- Raynes, C. and Tsui, K.W.H. (2019), “Review of Airline-within-Airline strategy: Case studies of the Singapore Airlines Group and Qantas Group”, *Case Studies on Transport Policy*, Vol. 7 No. 1, pp. 150–165, doi: 10.1016/j.cstp.2018.12.008.

## Appendix G - Bibliography

- Rhodes-Leader, L., Worthington, D.J., Nelson, B.L. and Onggo, B.S. (2018), “MULTI-FIDELITY SIMULATION OPTIMISATION FOR AIRLINE DISRUPTION MANAGEMENT”, *2018 Winter Simulation Conference (WSC)*, presented at the 2018 Winter Simulation Conference (WSC), IEEE, Gothenburg, Sweden, pp. 2179–2190, doi: 10.1109/WSC.2018.8632329.
- Rivera, G., Porras, R., Sanchez-Solis, J.P., Florencia, R. and García, V. (2022), “Outranking-based multi-objective PSO for scheduling unrelated parallel machines with a freight industry-oriented application”, *Engineering Applications of Artificial Intelligence*, Vol. 108, p. 104556, doi: 10.1016/j.engappai.2021.104556.
- Roy, B. (1991), “The outranking approach and the foundations of electre methods”, *Theory and Decision*, Vol. 31 No. 1, pp. 49–73, doi: <https://doi.org/10.1007/BF00134132>.
- Rubinstein, R.Y. (1997), “Optimization of computer simulation models with rare events”, *European Journal of Operational Research*, Vol. 99 No. 1, pp. 89–112, doi: 10.1016/S0377-2217(96)00385-2.
- Saaty. (1987), “The Analytic Hierarchy Process - What It Is And How It Is Used”, *Math. Modelling*, Vol. 9 No. 3–5, pp. 161–176.
- Saaty, T.L. (1982), *Decision Making for Leaders*, Wadsworth Publishing (1982).
- Saaty, T.L. (1989), “Group Decision Making and the AHP”, *The Analytic Hierarchy Process*, Golden B.L., Wasil E.A., Harker P.T., Springer, Berlin, Heidelberg.
- Saaty, T.L. (2004), “Fundamentals of the analytic network process — multiple networks with benefits, costs, opportunities and risks”, *Journal of Systems Science and Systems Engineering*, Vol. 13 No. 3, pp. 348–379, doi: 10.1007/s11518-006-0171-1.

- Santana, M., De La Vega, J., Morabito, R. and Pureza, V. (2023), “The aircraft recovery problem: A systematic literature review”, *EURO Journal on Transportation and Logistics*, Vol. 12, p. 100117, doi: 10.1016/j.ejtl.2023.100117.
- Schuetz, C.G., Lorünser, T., Jaburek, S., Schuetz, K., Wohner, F., Karl, R. and Gringinger, E. (2022), “A Distributed Architecture for Privacy-Preserving Optimization Using Genetic Algorithms and Multi-party Computation”, in Sellami, M., Ceravolo, P., Reijers, H.A., Gaaloul, W. and Panetto, H. (Eds.), *Cooperative Information Systems*, Vol. 13591, Springer International Publishing, Cham, pp. 168–185, doi: 10.1007/978-3-031-17834-4\_10.
- Schuetz, C.G., Ruiz, S., Gringinger, E. and Fabianek, C. (2022), “AN AUCTION-BASED MECHANISM FOR A PRIVACY-PRESERVING MARKETPLACE FOR ATFM SLOTS”, presented at the 33rd congress of the International Council of the Aeronautical Sciences, Stockholm, Sweden.
- Sen, A. and Foster, J.E. (1997), *On Economic Inequality*, Enl. ed., Clarendon Press ; Oxford University Press, Oxford : New York.
- Sharma, I. (2020), “Equity of transit connectivity in Tennessee cities”, *Journal of Transport Geography*, p. 20.
- Shiau, D.-F. (2011), “A hybrid particle swarm optimization for a university course scheduling problem with flexible preferences”, *Expert Systems with Applications*, Vol. 38 No. 1, pp. 235–248, doi: 10.1016/j.eswa.2010.06.051.
- Sinclair, K., Cordeau, J.-F. and Laporte, G. (2014), “Improvements to a large neighborhood search heuristic for an integrated aircraft and passenger recovery problem”, *European Journal of Operational Research*, Vol. 233 No. 1, pp. 234–245, doi: 10.1016/j.ejor.2013.08.034.

## Appendix G - Bibliography

- Sinclair, K., Cordeau, J.-F. and Laporte, G. (2015), “A column generation post-optimization heuristic for the integrated aircraft and passenger recovery problem”, *Computers & Operations Research*, Vol. 65, pp. 42–52, doi: 10.1016/j.cor.2015.06.014.
- Sousa, H., Teixeira, R., Lopes Cardoso, H. and Oliveira, E. (2015), “Airline Disruption Management - Dynamic Aircraft Scheduling with Ant Colony Optimization”:, *Proceedings of the International Conference on Agents and Artificial Intelligence*, presented at the International Conference on Agents and Artificial Intelligence, SCITEPRESS - Science and and Technology Publications, Lisbon, Portugal, pp. 398–405, doi: 10.5220/0005205303980405.
- Su, Y., Xie, K., Wang, H., Liang, Z., Art Chaovalitwongse, W. and Pardalos, P.M. (2021), “Airline Disruption Management: A Review of Models and Solution Methods”, *Engineering*, Vol. 7 No. 4, pp. 435–447, doi: 10.1016/j.eng.2020.08.021.
- Sugeno, M. (1974), *Theory of Fuzzy Integrals and Its Applications*, Tokyo Institute of Technology, Tokyo.
- Sun, Z. and Zacharias, J. (2020), “Transport equity as relative accessibility in a megacity: Beijing”, *Transport Policy*, Vol. 92, pp. 8–19, doi: 10.1016/j.tranpol.2020.03.016.
- Surekha, P. and Sumathi, S. (2011), “Research Scholar PSG College of Technology, Coimbatore, India surekha\_3000@yahoo.com”, Vol. 2, p. 9.
- Taddese, G.A. (2021), *Méthodologie de Prise de Décision Multicritère Pour l'évaluation de La Performance Durable Dans La Conception et La Fabrication Des Produits - Application à La Fabrication Additive*, Université Clermont Auvergne;Addis Ababa university, Clermont-Ferrand.
- Tasgetiren, M.F., Sevkli, M., Yun-Chia Liang and Gencyilmaz, G. (2004), “Particle swarm optimization algorithm for single machine total weighted tardiness problem”,



- Proceedings of the 2004 Congress on Evolutionary Computation (IEEE Cat. No.04TH8753)*, presented at the 2004 Congress on Evolutionary Computation, IEEE, Portland, OR, USA, pp. 1412–1419, doi: 10.1109/CEC.2004.1331062.
- Teodorović, D. and Guberinić, S. (1984), “Optimal dispatching strategy on an airline network after a schedule perturbation”, *European Journal of Operational Research*, Vol. 15 No. 2, pp. 178–182, doi: 10.1016/0377-2217(84)90207-8.
- Terrien, C. (2018), “Utilisation de l’intégrale de Choquet dans un système de recommandation objet basé sur un filtrage actif multicritères, mise en œuvre et perspectives : Application à la recommandation de jeans”, p. 13.
- Theil, H. (1967), “Economics and information theory”, *North-Holland, Amsterdam*.
- Toader, F.A. (2014), “Production scheduling by using ACO and PSO techniques”, *2014 International Conference on Development and Application Systems (DAS)*, presented at the 2014 International Conference on Development and Application Systems (DAS), IEEE, Suceava, Romania, pp. 170–175, doi: 10.1109/DAAS.2014.6842449.
- Vink, J., Santos, B.F., Verhagen, W.J.C., Medeiros, I. and Filho, R. (2020), “Dynamic aircraft recovery problem - An operational decision support framework”, *Computers & Operations Research*, Vol. 117, p. 104892, doi: 10.1016/j.cor.2020.104892.
- Vossen, T., Ball, M., Hoffman, R. and Wambsganss, M. (2003), “A General Approach to Equity in Traffic Flow Management and Its Application to Mitigating Exemption Bias in Ground Delay Programs”, *Air Traffic Control Quarterly*, Vol. 11 No. 4, doi: 10.2514/atcq.11.4.277.
- Wang, Y., Cao, M., Liu, Y., Ye, R., Gao, X. and Ma, L. (2020), “Public transport equity in Shenyang: Using structural equation modelling”, *Research in Transportation Business & Management*, p. 100555, doi: 10.1016/j.rtbm.2020.100555.

## Appendix G - Bibliography

- Wang, Z., Zhang, J. and Yang, S. (2019), “An improved particle swarm optimization algorithm for dynamic job shop scheduling problems with random job arrivals”, *Swarm and Evolutionary Computation*, Vol. 51, p. 100594, doi: 10.1016/j.swevo.2019.100594.
- Wanke, P., Pestana Barros, C. and Chen, Z. (2015), “An analysis of Asian airlines efficiency with two-stage TOPSIS and MCMC generalized linear mixed models”, *International Journal of Production Economics*, Vol. 169, pp. 110–126, doi: 10.1016/j.ijpe.2015.07.028.
- Woo, Y.-B. and Moon, I. (2021), “Scenario-based stochastic programming for an airline-driven flight rescheduling problem under ground delay programs”, *Transportation Research Part E: Logistics and Transportation Review*, Vol. 150, p. 102360, doi: 10.1016/j.tre.2021.102360.
- Yalcin Kavus, B., Gulum Tas, P., Ayyildiz, E. and Taskin, A. (2022), “A three-level framework to evaluate airline service quality based on interval valued neutrosophic AHP considering the new dimensions”, *Journal of Air Transport Management*, Vol. 99, p. 102179, doi: 10.1016/j.jairtraman.2021.102179.
- Yan, S., Zhang, G., Sun, J. and Zhang, W. (2023), “An improved ant colony optimization for solving the flexible job shop scheduling problem with multiple time constraints”, *Mathematical Biosciences and Engineering*, Vol. 20 No. 4, pp. 7519–7547, doi: 10.3934/mbe.2023325.
- Yang, T. and Hu, Y. (2019), “Considering Passenger Preferences in Integrated Postdisruption Recoveries of Aircraft and Passengers”, *Mathematical Problems in Engineering*, Vol. 2019, pp. 1–19, doi: 10.1155/2019/9523610.
- Yannis, G., Kopsacheili, A., Dragomanovits, A. and Petraki, V. (2020), “State-of-the-art review on multi-criteria decision-making in the transport sector”, *Journal of Traffic and*

- Transportation Engineering (English Edition)*, Vol. 7 No. 4, pp. 413–431, doi: 10.1016/j.jtte.2020.05.005.
- Yi, N., Xu, J., Yan, L. and Huang, L. (2020), “Task optimization and scheduling of distributed cyber–physical system based on improved ant colony algorithm”, *Future Generation Computer Systems*, Vol. 109, pp. 134–148, doi: 10.1016/j.future.2020.03.051.
- Young, H.P. (1974), “An axiomatization of Borda’s rule”, *Journal of Economic Theory*, Vol. 9 No. 1, pp. 43–52, doi: [https://doi.org/10.1016/0022-0531\(74\)90073-8](https://doi.org/10.1016/0022-0531(74)90073-8).
- Zagonari, F. (2018), “Responsibility, inequality, efficiency, and equity in four sustainability paradigms: Policies for a shared sea from a multi-country analytical model”, *Marine Policy*, Vol. 87, pp. 123–134, doi: 10.1016/j.marpol.2017.10.016.
- Zegordi, S.H. and Jafari, N. (2010), “Solving the Airline Recovery Problem by Using Ant Colony Optimization”, *International Journal of Industrial Engineering & Production Research*, Vol. 21 No. 3, pp. 121–128.
- Zhang, D., Henry Lau, H.Y.K. and Yu, C. (2015), “A two stage heuristic algorithm for the integrated aircraft and crew schedule recovery problems”, *Computers & Industrial Engineering*, Vol. 87, pp. 436–453, doi: 10.1016/j.cie.2015.05.033.
- Zhang, D., Yu, C., Desai, J. and Lau, H.Y.K.H. (2016), “A math-heuristic algorithm for the integrated air service recovery”, *Transportation Research Part B: Methodological*, Vol. 84, pp. 211–236, doi: 10.1016/j.trb.2015.11.016.
- Zhao, A., Bard, J.F. and Bickel, J.E. (2023), “A two-stage approach to aircraft recovery under uncertainty”, *Journal of Air Transport Management*, Vol. 111, p. 102421, doi: 10.1016/j.jairtraman.2023.102421.

## Appendix G - Bibliography

Zhao, P. and Cao, Y. (2020), “Commuting inequity and its determinants in Shanghai: New findings from big-data analytics”, *Transport Policy*, Vol. 92, pp. 20–37, doi: 10.1016/j.tranpol.2020.03.006.

Zhu, B., Clarke, J.-P. and Zhu, J. (2016), “Real-Time Integrated Flight Schedule Recovery Problem Using Sampling-Based Approach”, *Journal of Computational and Theoretical Nanoscience*, Vol. 13 No. 2, pp. 1458–1467, doi: 10.1166/jctn.2016.5068.