



HAL
open science

Geometry of horospherical products

Tom Ferragut

► **To cite this version:**

Tom Ferragut. Geometry of horospherical products. Mathematics [math]. Université de Montpellier, 2022. English. NNT : 2022UMONS045 . tel-04599464

HAL Id: tel-04599464

<https://theses.hal.science/tel-04599464>

Submitted on 3 Jun 2024

HAL is a multi-disciplinary open access archive for the deposit and dissemination of scientific research documents, whether they are published or not. The documents may come from teaching and research institutions in France or abroad, or from public or private research centers.

L'archive ouverte pluridisciplinaire **HAL**, est destinée au dépôt et à la diffusion de documents scientifiques de niveau recherche, publiés ou non, émanant des établissements d'enseignement et de recherche français ou étrangers, des laboratoires publics ou privés.

THÈSE POUR OBTENIR LE GRADE DE DOCTEUR DE L'UNIVERSITÉ DE MONTPELLIER

En Mathématiques et Modélisation

École doctorale : Information, Structure, Systèmes

Unité de recherche : Institut Montpellierain Alexander Grothendieck

Geometry of horospherical products

Présentée par Tom Ferragut
Le 04 Juillet 2022

Sous la direction de Constantin VERNICOS
et Jérémie BRIEUSSEL

Devant le jury composé de

Jérémie BRIEUSSEL, Maître de conférence, Université de Montpellier

Tullia DYMARZ, Associate Professor, University of Wisconsin

Thomas HAETTEL, Maître de conférence, Université de Montpellier

Peter HAÏNSSINSKY, Professeur, Université d'Aix-Marseille

Alessandra IOZZI, Professor, Eidgenössische Technische Hochschule (ETH) Zürich

Constantin VERNICOS, Maître de conférence, Université de Montpellier

Xie XIANGDONG, Professor, Bowling Green State University

Co-encadrant

Examinatrice

Examineur

Président du Jury

Examinatrice

Directeur

Rapporteur

Suite aux rapports de

Alex ESKIN, Distinguished Service Professor, University of Chicago

Xie XIANGDONG, Professor, Bowling Green State University

Rapporteur

Rapporteur



UNIVERSITÉ
DE MONTPELLIER

Geometry of horospherical products.

Tom Ferragut

Supervised by Jeremie Brieussel and Constantin Vernicos

September 21, 2022

Abstract

In this manuscript we study the geometry of some metric spaces called horospherical product. They are constructed out of two Gromov hyperbolic spaces, and contains both discrete or continuous examples such as the Diestel-Leader graphs, the SOL geometry or the treebolic spaces.

In the first part of this manuscript, we consider two proper, geodesically complete, Gromov hyperbolic, Busemann spaces X and Y . We construct their horospherical product $X \rtimes Y$ and, after some metric estimations on specific paths in Gromov hyperbolic spaces, we describe a family of distances on $X \rtimes Y$. More specifically, we show that all these distances produce the same large scale geometry for $X \rtimes Y$. This description allows us to depict the shape of geodesic segments and geodesic lines. The understanding of the geodesics' behaviour leads us to the characterization of the visual boundary of $X \rtimes Y$.

For the second part, the two spaces X and Y are endowed with measures. Thanks to these measures, we manage to achieve the geometric rigidity of self quasi-isometries of $X \rtimes Y$. More specifically, we show that every self quasi-isometry Φ of $X \rtimes Y$ is close to a product map (Φ^X, Φ^Y) , where $\Phi^X : X \rightarrow X$ and $\Phi^Y : Y \rightarrow Y$ are two quasi-isometries. To do so, we first develop several metric and measure theoretic tools regarding a specific family of geodesic called *vertical* geodesics. These tools include the *coarse differentiation*, introduced by Eskin, Fisher and Whyte for the horospherical product of regular infinite trees and hyperbolic planes. Afterwards, generalising techniques they presented, we obtain geometric rigidity.

In the last chapter we present an example on how to use this geometric rigidity on $X \rtimes Y$ in order to get informations on its quasi-isometry group. More precisely, we provide a description of the quasi-isometry group of a family of solvable Lie groups of the form $\mathbb{R} \rtimes_{\text{Diag}(A_1, -A_2)} (N_1 \times N_2)$, where N_1, N_2 are nilpotent Lie groups and where A_1 and A_2 are matrices whose eigenvalues have all positive real parts.

Contents

Remerciements	5
Résumé en français	7
1 Introduction	11
1.1 Coarse geometry	11
1.1.1 Metric spaces and geodesics	11
1.1.2 Gromov hyperbolic spaces	11
1.1.3 Quasi-isometries	12
1.2 Horospherical products	12
1.2.1 Vertical geodesics and Busemann functions	12
1.2.2 Definition and examples	13
1.2.3 Some Lie groups as horospherical products	14
1.2.4 Quasi-isometry classification and rigidity results	15
1.2.5 Admissible measures	16
1.3 Results of this thesis	17
1.3.1 Geodesics and visual boundary	17
1.3.2 Geometric description of quasi-isometries	19
1.4 Possible further developments	21
1.5 Structure of the manuscript	22
I Geodesic and visual boundary of horospherical product	23
2 Context	25
2.1 Gromov hyperbolic spaces	25
2.2 Vertical geodesics with respect to a boundary point	25
2.3 Busemann spaces	27
3 Metric estimates in Gromov hyperbolic Busemann spaces	29
3.1 Metric description of geodesics	29
3.2 Length estimate of paths avoiding horospheres	31
4 Horospherical products	41
4.1 Definitions	41
4.2 Examples	45
4.3 Length of geodesic segments in $X \rtimes Y$	46
5 Shapes of geodesics and visual boundary of $X \rtimes Y$	51
5.1 Shapes of geodesic segments	51
5.2 Coarse monotonicity	56
5.3 Shapes of geodesic rays and geodesic lines	57
5.4 Visual boundary of $X \rtimes Y$	60

II Coarse differentiation and quasi-isometries product maps	63
6 Notations on horospherical products	65
7 Metric aspects and metric tools in horospherical products	71
7.1 ε -monotonicity	71
7.2 Coarse differentiation of a quasigeodesic segment	77
7.3 Height respecting tetrahedric quadrilaterals	80
7.4 Orientation and tetrahedric quadrilaterals	82
8 Measure and Box-tiling	89
8.1 Appropriate measure and horopointed admissible space	89
8.2 Box-tiling of X	92
8.3 Tiling a big box by small boxes	94
8.4 Box-tiling of $X \rtimes Y$	95
8.5 Measure of balls, boxes and neighbourhoods	97
8.6 Set of vertical geodesics	98
8.7 Projections of set of almost full measure	101
8.8 Divergence	108
9 Proof of the geometric rigidity	111
9.1 Vertical geodesics with ε -monotone image	111
9.2 Factorisation of a quasi-isometry in small boxes	116
9.3 Shadows and orientation	119
9.4 Factorisation of a quasi-isometry in big boxes	125
9.5 A quasi-isometry quasi-respects the height	128
9.6 Factorisation of a quasi-isometry on the whole space	131
10 Some solvable Lie groups as horospherical products	133
10.1 Admissibility of Heintze groups	133
10.2 Precision on the components of the product map	134
10.3 Hamenstädt distance and Product map of Bi-Lipschitz functions.	136

Remerciements

Cette quatre années ont été une expérience incroyable, qui m'a confirmée que je voulais faire de la recherche mon métier. Le bon déroulement et l'aboutissement de cette thèse ont été possibles grâce au soutien d'un grand nombre de personnes.

Je souhaite tout d'abord remercier Jérémie et Constantin, pour le temps qu'ils m'ont consacré. Leur bienveillance, leur patience et leur investissement constants ont été précieux si ce n'est indispensables pour écrire ce manuscrit, je leur suis infiniment reconnaissante.

Je remercie Alex Eskin et Xiangdong Xie d'avoir accepté d'être rapporteurs pour cette thèse, ainsi que Tullia Dymarz, Thomas Haettel, Alessandra Iozzi et Peter Haïssinsky d'avoir bien voulu faire parti du jury de ma soutenance, j'ai été honoré de votre participation. Merci également à Xiangdong Xie d'avoir pris le temps de venir à Montpellier au début de mon doctorat, et pour ces remarques très instructives sur ce sujet de recherche.

Un grand merci à tous le personnel de l'IMAG pour leur accueil et leur présence au long de ces quatre années. Je remercie en particulier l'équipe GTA pour les discussions scientifiques et les moments de convivialités.

Merci également à l'ensemble des doctorant-e-s du premier et deuxième étage du bâtiment 9. Merci à André, Gwénaél, Albin, Corina, Florian, Tiffany et Florent pour l'amaretto, Hanine pour le badminton, Pascal, Alain, Marien pour les ramens, Raphaël, Zaineb pour ton énergie positive, Steven, Emanuel, Ines, Tanguy, Ivan pour tes illustrations magnifiques, Radia, Antonia, Thiziri pour ta présence apaisante, Thibault, Lucie pour Guinness, Aurelio pour les carbonara, Pablo, Juliette pour les brunch, Hermes, Mireille pour ce dernier semestre, Nathan, Morgane, Barth, Zakaria et Victor pour la partage du bureau et du tableau, Guillaume pour le festival, Julien pour le premier cinéma (rien d'autre bien-sûr) et Alan pour ces soirées Kung-Fu, bières, billards. Merci également à Oussama pour sa bonne humeur lors de toutes ces conférences.

Je dois également cette thèse à beaucoup d'autres personnes, qui m'ont m'accompagnées pendant, ou avant ces années à Montpellier. Merci à Pierre pour ton sourire imperturbable et merci à Gilles pour ton accueil chaleureux et pour toute l'aide que tu m'as apportée. Merci au groupe des nouveaux, Cedric, Oriane et Laura, et merci à mes amies de l'improvisation Julien, Antoine, Oriane et Stéphanie, Thibault et Hélène. Vous m'avez permis de profiter pleinement de ces cinq années.

Avant Montpellier il y a eu ces trois années à Rennes, où j'ai rencontré ces merveilleuses personnes. Merci à Cong Bang, Lise, Amandine, Fabrice pour le NomNom, Noémie, Octave pour ces conférences, Camille ma coéquipière d'agreg, Juliette, Léo pour la semi/presque sûr colocation, Lucile et Antoine pour la pastèque One Piece. Je remercie également Anne-Marie Kermarrec et Carlo Petronio de m'avoir fait découvrir le monde de la recherche.

Merci aux camarades de prépa Nicolas, Sébastien, Damien, Amélie et Mathieu d'avoir été présent à la fois dans le stress (la douleur ?) et le rire pendant ces deux années à Vannes. Merci également à Lucile, Mathilde, Sophie et Mailis pour ces soirées d'été, et pleins d'autres moments.

Je remercie Nicolas Sans, qui par sa passion pour l'enseignement m'a donné le goût de continuer dans les mathématiques, que ce soit l'enseignement pour espérer transmettre les mathématiques comme il le fait, ou dans la recherche de par les divers problèmes qu'il nous posait. Restons à Auray, du fond du coeur, merci à Margaux, Camille, Clément, Pauline, Julia, Antonin, Korentin et Quentin. Depuis le lycée, ou même le collège, vous me supportez, sans vous je serais définitivement une personne différente.

Enfin je voudrais remercier ma famille, qui m'a aidé à me forger depuis que je suis tout petit. Merci à mes grands-parents, à qui je pense très fort, merci à mes cousins, mes cousines, mes oncles et mes tantes.

Et bien-sûr merci à Papa, Maman et Kevin pour votre amour débordant. C'est une joie de faire partie de cette famille, je réalise tout les jours l'immense chance que j'ai de vous avoir. Je pourrais écrire une autre thèse sur tout ce que je vous dois, mais je resterai sobre. Vous êtes des personnes formidables, merci, merci et merci.

Pour terminer, merci à toi Amandine. Infiniment merci.

Résumé en français

La géométrie d'un objet mathématique peut être appréhendée d'un grand nombre de façons différentes. Dans ce manuscrit de thèse, nous allons explorer la géométrie d'espaces appelés **produits horosphériques**, grâce notamment à l'étude de différents aspects tels que leurs distances ou leurs mesures.

Dans la première partie, nous nous intéresserons à la forme des géodésiques, autrement dit, aux manières de voyager le plus rapidement possible entre deux points de notre espace. En nous servant de cette description, nous serons en mesure de donner une caractérisation du bord à l'infini de ces produits horosphériques. Ce bord peut être compris comme la famille des directions possibles lorsque l'on choisit de voyager à l'infini.

Dans la deuxième partie de ce travail, nous étudierons la géométrie à grande échelle des produits horosphériques. L'objectif principal de cette partie est de montrer que les **quasi-isométries**, c'est à dire des fonctions ne modifiant pas la géométrie à grande échelle, vérifient une certaine propriété de *rigidité géométrique*.

Pour pouvoir être plus précis, explicitons le contenu des différents chapitres composant ce manuscrit.

Chapitre 2

Soit (X, d_X) un espace métrique. Un triangle géodésique de X est la donnée de trois points a, b et c de X , les sommets, ainsi que de trois géodésiques reliant les points deux à deux, les côtés.

Soit $\delta \geq 0$, l'espace X est appelé δ -hyperbolique (ou **Gromov hyperbolique**) si pour tout triangle géodésique, tout point contenu dans l'un des côtés est à distance plus petite que δ d'un des deux autres côtés. En particulier, le triangle géodésique ressemble (à δ près) à un tripode. Cette hyperbolicité au sens de Gromov est une caractérisation métrique de la courbure négative d'un espace.

En plus d'être Gromov hyperbolique, nous demanderons à ce que X soit **Busemann**, c'est à dire que l'évolution de la distance entre deux segments géodésiques soit une fonction convexe. Cette hypothèse nous permet de significativement alléger l'écriture des démonstrations présentes dans ce manuscrit.

Un espace Gromov hyperbolique X est naturellement muni d'un bord à l'infini (bord visuel, ou bord de Gromov) noté ∂X . Fixons un point $a \in \partial X$ sur ce bord et un point base $w \in X$. Il en découle alors une **fonction de hauteur** $h_X : X \rightarrow \mathbb{R}$, définie comme l'opposée d'une fonction de Busemann, relative à ce couple (a, w) . Si l'on imagine que la direction a est représentée vers le haut, cette fonction de hauteur h_X représente l'altitude d'un point de X . Les géodésiques infinies, voyageant en direction de a sont alors appelées **géodésiques verticales**. Ces géodésiques particulières jouent un rôle essentiel dans l'ensemble de ce document.

Chapitre 3

Dans ce chapitre nous nous concentrons sur la forme des géodésiques d'un espace hyperbolique, ainsi que sur la longueur de chemins ne dépassant pas une certaine hauteur.

Plus précisément, une géodésique est toujours contenue dans un voisinage proche de deux géodésiques verticales. Cela permet de décomposer cette géodésique en deux temps : en phase ascendante, puis une phase descendante. La hauteur maximale atteinte par une géodésique reliant deux points a et b de X , notée h^+ , est étroitement liée à la distance entre a et b .

Considérons $\Delta \geq 0$. Nous montrons que tout chemin γ reliant a et b , et dont la hauteur ne dépasse pas $h^+ - \Delta$ possède une longueur $l(\gamma)$ supérieure à $e^\Delta + d_X(a, b)$.

Chapitre 4

Etant donnés deux espaces Gromov hyperboliques et Busemann X et Y , munis respectivement de leur hauteur h_X et h_Y , nous pouvons définir leur produit horosphérique que l'on note $X \bowtie Y$ comme :

$$X \bowtie Y := \{(x, y) \in X \times Y \mid h_X(x) = -h_Y(y)\}.$$

Cet espace $X \bowtie Y$ est inclus dans le produit cartésien $X \times Y$ et peut être compris comme le recollage de X et d'une copie de Y que l'on a retournée le long de sa hauteur.

La géométrie Sol, une des huit géométries de Thurston, les graphes de Diestel-Leader et les 2-complexes de Cayley des groupes de Baumslag-Solitar $BS(1, n)$ sont des produits horosphériques, dont les deux composantes X et Y sont soit un arbre régulier infini, soit le plan hyperbolique \mathbb{H}^2 .

Nous pouvons visualiser un produit horosphérique comme un espace muni de trois directions, la direction verticale donnée par la hauteur, la direction de X pour la première coordonnée et la direction de Y pour la deuxième coordonnée. Une géodésique évoluant dans la direction X doit alors gagner en hauteur pour ne pas voir sa longueur exploser, cela découle du contrôle sur la longueur d'un chemin du chapitre 3. Dans la direction Y , comme cet espace est *retourné*, une géodésique voyageant dans cette direction doit suffisamment descendre pour ne pas voir sa longueur exploser.

Ces deux restrictions nous permettent de décrire (à une constante additive uniforme près) une famille de distances sur ces produits horosphériques.

Chapitre 5

Grâce à cette description de la distance, nous sommes capable de décrire géométriquement les segments et rayons géodésiques de $X \bowtie Y$. En particulier, nous montrons que ces géodésiques sont contenues dans un petit voisinage de la réunion de une, deux ou trois géodésiques verticales. Cette description rappelle le comportement des géodésiques dans un espace Gromov hyperbolique, qui sont contenues dans le voisinage de une ou deux géodésiques verticales.

Ayant une description précise des rayons géodésiques, nous en déduisons que le bord visuel de $X \bowtie Y$ est la réunion du bord visuel épointé de X et du bord visuel épointé de Y .

Le chapitre 5 conclut la première partie de ce manuscrit, dans laquelle nous avons exclusivement utilisé des outils métriques tels que l'inégalité triangulaire ou la rigidité des chemins dans un espace Gromov hyperbolique. Dans la deuxième partie, nous approfondissons ces aspects métriques et nous les combinons avec des outils de mesures nous permettant ainsi d'avoir des résultats non plus sur les géodésiques, mais sur les *quasi*-géodésiques des produits horosphériques.

Une **quasi-isométrie** est une fonction qui, modulo une constante multiplicative et une constante additive, ne modifie pas la distance d'un espace. Un des objectifs principaux de cette deuxième partie est de montrer qu'une quasi-isométrie Φ de $X \bowtie Y$ dans lui-même est proche d'un couple de quasi-isométries (Φ^X, Φ^Y) , où Φ^X est à valeurs dans X et Φ^Y est à valeurs dans Y . C'est ce phénomène que l'on appelle *rigidité géométrique*.

Chapitre 6

Dans le chapitre 6, premier chapitre de la seconde partie de ce manuscrit, nous introduisons quelques notations en rapport avec le *flot vertical* d'un espace Gromov hyperbolique X . Considérons une ligne de niveau H_0 (aussi appelée **horosphère**) de notre fonction de hauteur h_X . La projection (le long du flot vertical) d'un sous-ensemble U de H_0 , sur une autre ligne de niveau H_1 , est l'ensemble des points de H_1 reliés à U par une géodésique verticale. L'étude de ces projections, ainsi que de l'évolution de leurs mesures, jouent un rôle essentiel dans l'obtention du résultat principal de cette deuxième partie.

Pour cette raison, nos espaces X et Y ont besoin d'être des espaces mesurés en plus d'être des espaces métriques.

Chapitre 7

Dans ce chapitre nous développons l'ensemble des outils métriques dont nous aurons besoin dans le chapitre 9. Le premier d'entre eux porte le nom de chemin ε -**monotone**. Ce sont des chemins qui ne traversent pas deux fois une même ligne de niveaux en deux temps éloignés (l'éloignement étant notamment restreint par le paramètre ε). Nous montrons notamment que ces chemins sont uniformément proches de géodésiques verticales mentionnées précédemment. Le deuxième outil se nomme **différentiation grossière**. Cela consiste à découper une **quasi-géodésique** (image d'une géodésique par une quasi-isométrie) en un ensemble de morceaux de même longueur. Nous pouvons alors montrer que, dans le cadre d'un produit horosphérique, il existe une échelle R pour laquelle la majorité de ces morceaux de longueur R sont ε -monotones. Nous en déduisons ensuite que ces morceaux sont proches de géodésiques verticales.

Enfin, nous introduisons les quadrilatères tétraédriques, une configuration particulière constituée de quatre points d'un produit horosphérique. Quatre points $a, b, c, d \in X \times Y$ réalisent cette configuration si deux d'entre eux, disons a et b , sont reliés par des géodésiques verticales aux deux autres points c et d . Dans ce cas, a et b sont *presque* sur la même ligne de niveau et c et d sont *presque* sur la même ligne de niveau. Les deux points a et b partagent alors *presque* la même coordonnée en X , et c et d la même coordonnée en Y .

L'intérêt de ce quadrilatère réside dans le fait qu'il impose une même coordonnée en X et une même coordonnée en Y , sous condition que nos points soient reliés par des géodésiques verticales. Cependant nous venons de voir que, en un certain sens, *presque* tous les morceaux d'une quasi-géodésique sont proches de géodésiques verticales, ainsi l'image d'un quadrilatère tétraédrique par une quasi-isométrie a de grandes chances d'être *proche* d'un quadrilatère tétraédrique. Dans le chapitre suivant nous ajoutons des mesures sur nos espaces X et Y , cela nous permet notamment de manipuler correctement ces notions de " *presque* tous les morceaux ".

Chapitre 8

Nos espaces X et Y devant être considérés comme des espaces mesurés, nous ajoutons quelques hypothèses liées aux mesures sur ces deux espaces métriques. En particulier, nous demandons à ce que chacun d'eux possède une mesure μ^X , respectivement μ^Y , *désintégrable* sur les lignes de niveaux. C'est à dire que la mesure μ^X d'un ensemble peut être obtenue comme l'intégrale des mesures de ses intersections avec les lignes de niveaux de h_X .

Une géodésique verticale dont l'image par la quasi-isométrie Φ est proche d'une géodésique verticale est appelé une **bonne** géodésique verticale. Afin d'utiliser l'échelle R fournie par la différentiation grossière, nous pavons notre espace $X \times Y$ par des *boîtes* d'échelle R , que l'on peut se représenter comme des cubes de côté R , dont le flot vertical ne modifie pas les coupes horizontales. Nous en déduisons que dans presque toute ces boîtes \mathcal{B} , presque tout (pour une mesure contruite à partir de μ^X et μ^Y) les morceaux de géodésiques verticales sont des morceaux de bonne géodésiques verticales.

Chapitre 9

Ce chapitre réalise la démonstration du fait qu'une quasi-isométrie Φ de $X \rtimes Y$ vers lui-même est proche d'une quasi-isométrie appelée **produit**, de la forme (Φ^X, Φ^Y) , où Φ^X et Φ^Y sont des quasi-isométries respectivement de X et de Y . Cette démonstration fait appel à l'ensemble des outils métriques et de mesure que l'on a développés tout au long des chapitres 7 et 8.

Nous commençons par considérer une boîte \mathcal{B} d'échelle R dans laquelle presque tous les morceaux de géodésiques verticales sont des bons segments verticaux. Dans ce contexte, à partir de deux points a et b de \mathcal{B} partageant une même coordonnée en X , nous pouvons construire un quadrilatère tétraédrique dont l'image par Φ est proche d'un quadrilatère tétraédrique. Ainsi nous montrons que $\Phi(a)$ et $\Phi(b)$ partagent *presque* la même coordonnée en X . En réalisant le même raisonnement pour les coordonnées en Y , nous en déduisons que sur la boîte \mathcal{B} , la quasi-isométrie Φ est proche d'une quasi-isométrie produit (Φ^X, Φ^Y) .

En passant à une échelle plus grande $L > R$, nous sommes capables de montrer que cette dernière propriété n'est pas seulement vraie pour une majorité de boîtes d'échelle L , mais bien pour toutes ces dernières. Pour en déduire que Φ est proche d'une quasi-isométrie produit sur tout l'espace, nous considérons deux points a et b de $X \rtimes Y$ possédant le même coordonnée en X . Nous construisons ensuite deux suites de boîtes $(\mathcal{B}_{a,n})_{n \in \mathbb{N}}$ et $(\mathcal{B}_{b,n})_{n \in \mathbb{N}}$ d'échelle croissante de la forme $L_n = (1 + \beta)^n L$, dont tous les termes contiennent respectivement a ou b . Ici β est un nombre plus petit que 1. Alors, nous pouvons faire coïncider ces deux suites à partir d'un certain rang. Cela nous permet de construire de proche en proche un quadrilatère tétraédrique contenant a et b , dont l'image par Φ est proche d'un quadrilatère tétraédrique.

Nous en déduisons que $\Phi(a)$ et $\Phi(b)$ possèdent presque la même coordonnée en X , et, après un travail similaire en Y , que Φ est proche d'une quasi-isométrie produit sur tout $X \rtimes Y$. Cela conclut la preuve du résultat principal de ce manuscrit. Le chapitre suivant propose un exemple d'application de ce résultat, grâce auquel nous obtenons une description du groupe de quasi-isométrie d'une famille de groupes de Lie résolubles.

Chapitre 10

Dans ce chapitre nous considérons les produits horosphériques de *groupes de Heintze*, qui se trouvent être les seules variétés simplement connexes homogènes de courbure négative pincées. Ces groupes de Heintze sont de la forme $\mathbb{R} \rtimes_A N$, où N est un groupe de Lie nilpotent simplement connexe, et où la matrice A agit par dérivation au niveau de l'algèbre de Lie associée à N . Ici toutes les valeurs propres de A possèdent une partie réelle strictement positive. Le produit horosphérique de deux groupes de Heintze $\mathbb{R} \rtimes_{A_1} N_1$ et $\mathbb{R} \rtimes_{A_2} N_2$ est alors

$$(\mathbb{R} \rtimes_{A_1} N_1) \rtimes (\mathbb{R} \rtimes_{A_2} N_2) = \mathbb{R} \rtimes_{\text{Diag}(A_1, -A_2)} (N_1 \times N_2).$$

Grâce au théorème que nous avons démontré dans le chapitre précédent, nous sommes en mesure de dire qu'une quasi-isométrie Φ de ce produit horosphérique dans lui-même est proche d'une quasi-isométrie produit (Φ_1, Φ_2) , où Φ_i est une quasi-isométrie de $\mathbb{R} \rtimes_{A_i} N_i$. En raffinant notre étude de Φ_i , nous montrons qu'il existe Ψ_i , une fonction bi-Lipschitz de N_i , telle que Φ_i est proche de $(\text{id}_{\mathbb{R}}, \Psi_i)$. C'est ainsi que nous caractérisons le groupe de quasi-isométries de $\mathbb{R} \rtimes_{\text{Diag}(A_1, -A_2)} (N_1 \times N_2)$ comme le produit cartésien des groupes de fonctions bi-Lipschitz de N_1 et de N_2 .

Chapter 1

Introduction

In this doctoral dissertation we study geometric aspects of some metric spaces called *horospherical products*. Notably, we provide a description of their *geodesics* (up to uniform finite distance), their *visual boundaries* and their *self quasi-isometries*. These results are obtained using metric and measure tools developed throughout this thesis, and, for the second part of this manuscript, following techniques presented by Eskin, Fisher and Whyte in [10].

1.1 Coarse geometry

1.1.1 Metric spaces and geodesics

Let (X, d_X) be a metric space. A geodesic segment of X is the image by an isometry of a closed real interval into X . A geodesic segment between two points $a, b \in X$, denoted by $[a, b]$, is a shortest path (with respect to d_X) between a and b .

Depending on the intrinsic geometry of X , these geodesic segments may behave in various ways. They can be unique, infinitely many, dead-ends or extendable towards infinity. The understanding of their shape or their length provides informations on the metric space (X, d_X) . A metric space is called **geodesic** if, for any two points $x, x' \in X$, there exists a geodesic segment between them.

A geodesic ray is the image by an isometry of the half-line $[0; +\infty[$ into X . Let $r > 0$ and let U be a subset of X , the r -neighbourhood of U , denoted by $\mathcal{N}_r(U)$ is the set of points r -close to U , that is,

$$\mathcal{N}_r(U) := \{x \in X \mid d_X(x, U) \leq r\}.$$

Thanks to this neighbourhood, we consider the following equivalence relation on geodesic rays.

Definition 1.1.1. Let α_1 and α_2 be two geodesic rays.

$$\alpha_1 \sim \alpha_2 \Leftrightarrow \exists r > 0 \text{ such that } \alpha_1 \subset \mathcal{N}_r(\alpha_2) \text{ and } \alpha_2 \subset \mathcal{N}_r(\alpha_1)$$

The **visual boundary** of X , denoted by ∂X , is the set of equivalence classes of geodesic rays for the aforementioned relation. This boundary at infinity depicts the different possible directions of geodesic rays.

1.1.2 Gromov hyperbolic spaces

In Euclidean spaces, the study of triangles naturally follows the study of geodesic segments. The same idea holds in general metric spaces. Let $a, b, c \in X$ be three points, a geodesic triangle consists of three geodesic segments $[a, b], [b, c]$ and $[c, a]$, when they exist. Using these geodesic triangles, Gromov introduced a metric characterisation of the negative curvature, generalising Riemannian manifolds with negative sectional curvature.

Definition 1.1.2.

Let $\delta \geq 0$, a geodesic metric space X is δ -hyperbolic if and only if for all $a, b, c \in X$, any of the three sides composing the geodesic triangle $[a, b] \cup [b, c] \cup [c, a]$ is contained in the δ -neighbourhood of the two others.

A geodesic metric space is called **Gromov hyperbolic** if it is δ -hyperbolic for some $\delta \geq 0$.

This definition is in fact a coarse generalisation of negative curvature since all simply connected Riemannian manifolds with negative sectional curvature are δ -hyperbolic for some δ . Moreover, the family of Gromov hyperbolic spaces gathers a broad set of discrete objects, such as trees, which are 0-hyperbolic since their geodesic triangles are all tripods.

1.1.3 Quasi-isometries

Another approach to study the geometry of a metric space (X, d_X) is to consider its global structure, or its structure at infinity. With that in mind, the notion of isometry between X and Y might be too restricting. Indeed, allowing some controlled perturbation between X and Y , thanks to *quasi-isometries*, can give access to new understandings on the large scale geometry of both X and Y .

Definition 1.1.3. Let (X, d_X) and (Y, d_Y) be two metric spaces. A map $\Phi : X \rightarrow Y$ is called a (k, c) -quasi-isometry if and only if:

- (1) For all $x, x' \in X$, $k^{-1}d_X(x, x') - c \leq d_Y(\Phi(x), \Phi(x')) \leq kd_X(x, x') + c$.
- (2) For all $y \in Y$, there exists $x \in X$ such that $d(\Phi(x), y) \leq c$.

A map verifying (1) is called a *quasi-isometric embedding* of X .

We say that two metric spaces are quasi-isometric if there exists a quasi-isometry between them. In [18] Gromov], a mainstay of geometric group theory, Gromov points out the importance of quasi-isometric invariants in groups. The quasi-isometry classification of groups, or metric spaces, has since been a wide and prolific research domain (see [21] Kapovich] for a nice survey on this topic).

This manuscript lies in this field. Notably we provide a description of the quasi-isometry group of a family of solvable Lie groups, and a geometric description of quasi-isometries of a wide family of metric spaces called *horospherical product*.

1.2 Horospherical products**1.2.1 Vertical geodesics and Busemann functions**

Let X be a Gromov hyperbolic space, and let us fix a point $a \in \partial X$ on the boundary. We call **vertical geodesic ray**, respectively **vertical geodesic line**, any geodesic ray in the equivalence class a , respectively with one of its rays in a . The study of these specific geodesic rays is central in this work.

A metric space (X, d_X) is **Busemann** if and only if for every pair of geodesic segments parametrized by arclength $\gamma : [a, b] \rightarrow X$ and $\gamma' : [a', b'] \rightarrow X$, the following function is convex:

$$D_{\gamma, \gamma'} : [a, b] \times [a', b'] \rightarrow X$$

$$(t, t') \mapsto d_X(\gamma(t), \gamma'(t')).$$

The Busemann assumption removes some technical difficulties in a significant number of proofs in this work. For example, if X is a Busemann space in addition to being Gromov hyperbolic, for all $x \in X$ there exists a unique vertical geodesic ray, denoted by V_x , starting at x . The construction of the *horospherical product* of two Gromov hyperbolic space X and Y requires the so called **Busemann functions**. Their definition is simplified by the Busemann assumption. Let us consider ∂X , the Gromov boundary of X (which, in this setting, is the same as the visual boundary). Both the boundary ∂X and

$X \cup \partial X$, endowed with the natural Hausdorff topology, are compact. Then, given $a \in \partial X$ a point on the boundary, and $w \in X$ a base point, we define a Busemann function $\beta_{(a,w)}$ with respect to a and w . Let V_w be the unique vertical geodesic ray starting from w .

$$\forall x \in X, \beta_{(a,w)}(x) := \limsup_{t \rightarrow +\infty} (d(x, V_w(t)) - t) \quad .$$

This function computes the asymptotic delay a point $x \in X$ has in a race towards a against the vertical geodesic ray starting at w . We call **height function**, denoted by h , the opposite of the Busemann function, $h := -\beta_{(a,w)}$. The **horospheres** of X with respect to $(a, w) \in \partial X \times X$ are the level-sets of $\beta_{(a,w)}$ (or of h).

These horospheres depend on the previously chosen couple (a, w) of $\partial X \times X$. Vertical geodesic rays can be heuristically considered as being "normal" to these horospheres. In the subsequent chapters, we will study how some measures on horospheres behave under the "vertical flow" provided by these vertical geodesics.

An **ideal triangle** of X is a geodesic triangle with one, or several, of its vertices on the Gromov boundary ∂X . Its edges can therefore be geodesic rays or geodesic lines of X . These ideal triangles are also δ' -thin for some δ' depending only on δ .

Thereby, considering the ideal triangles that admit the point $a \in \partial X$ as a vertex, we have that for all $x_1, x_2 \in X$, the geodesic $[x_1, x_2]$ is included in the δ' -neighbourhood of the two vertical geodesics $V_{x_1} \cup V_{x_2}$. It means that the geodesic first follows the path of V_{x_1} (with an increasing height h), then once it (almost) reaches the vertical geodesic ray V_{x_2} , it follows its path until x_2 (with a decreasing height h). Coarsely speaking, all geodesic segments are constructed from two portions of vertical geodesics. This configuration is illustrated on Figure 1.1 for the Log model of the hyperbolic plan \mathbb{H}^2 .

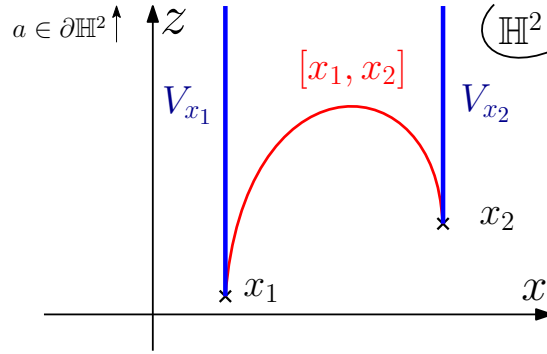

$$\mathbb{R}^2; ds^2 = e^{-2z} dx^2 + dz^2$$

Figure 1.1: Vertical geodesic rays in the Log model of \mathbb{H}^2 .

1.2.2 Definition and examples

Let X, Y be two Gromov hyperbolic spaces, let $a^X \in \partial X, a^Y \in \partial Y$ be points on the boundaries and let $w^X \in X, w^Y \in Y$ be base points. Let us denote by $h^X := -\beta_{(a^X, w^X)}$ and $h^Y := -\beta_{(a^Y, w^Y)}$ the two corresponding height functions. The **horospherical product** of X and Y , relatively to (a^X, w^X) and (a^Y, w^Y) , denoted by $X \bowtie Y$ is defined by:

$$X \bowtie Y := \{(x, y) \in X \times Y \mid h^X(x) + h^Y(y) = 0\}$$

The set $X \rtimes Y$, can be seen as a diagonal in $X \times Y$. It is constructed by gluing X with an upside down copy of Y along their respective horospheres.

To study the geometry of a horospherical product $X \rtimes Y$, we make additional assumptions on X and Y . We require them to be Gromov hyperbolic, Busemann, *geodesically complete* and *proper* metric spaces.

1. X is *geodesically complete* if and only if all geodesic segments of X can be extended into a geodesic bi-infinite line.
2. X is *proper* if and only if all closed metric balls of X are compact.

If X and Y satisfy these two additional conditions, the horospherical product $X \rtimes Y$ is connected (see Property [4.1.11](#)).

Example 1.2.1. *Let X be a Gromov hyperbolic, Busemann, geodesically complete and proper metric space. Then $X \rtimes \mathbb{R}$ is isometric to X . In particular, if V^Y is a vertical geodesic line of Y , $X \rtimes V^Y$ is an isometric embedding of X in $X \rtimes Y$.*

The three (non-trivial) first examples of horospherical products appeared independently in the literature. They correspond to the case where X and Y are either a regular infinite tree T_m of degree m or the hyperbolic plan \mathbb{H}^2 .

1. $T_m \rtimes T_n$ is the Diestel-Leader graph $DL(m, n)$. When $m = n$, this horospherical product is a Cayley graph of the lamplighter group $\mathbb{Z} \wr \mathbb{Z}_m$. See Figure [1.2](#) for a subset of $T_3 \rtimes T_3$.
2. $\mathbb{H}^{2,m} \rtimes \mathbb{H}^{2,n}$ is the Lie group $\mathbb{R} \rtimes_{(m,n)} \mathbb{R}^2 = \text{Sol}(m, n)$, one of the eight Thurston geometries. By $\mathbb{H}^{2,m}$ we mean the manifold \mathbb{R}^2 endowed with the infinitesimal Riemannian metric $ds^2 = e^{-2mz} dx^2 + dz^2$. The action associated to the aforementioned semi-direct product is described by $(z, (x, y)) \mapsto (e^{mz}x, e^{-nz}y)$.
3. $T_m \rtimes \mathbb{H}_2$ is a Cayley 2-complex of the Baumslag-Solitar group $BS(1, m)$.

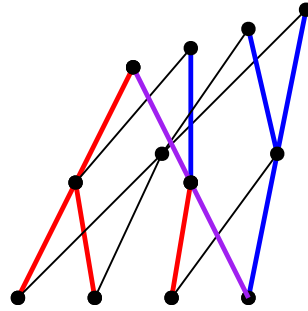

Figure 1.2: Small neighbourhood in $T_3 \rtimes T_3$.

The awareness of them being identically constructed from Gromov hyperbolic spaces came later, a survey on these three examples is provided by Wolfgang Woess in [\[28\]](#).

1.2.3 Some Lie groups as horospherical products

An other approach, is to consider the hyperbolic plan $\mathbb{H}^{2,m}$ as the affine Lie group $\mathbb{R} \rtimes_m \mathbb{R}$ with action by multiplication $(z, x) \mapsto e^{mz}x$, and the Sol geometry $\text{Sol}(m, n)$ as the Lie group $\mathbb{R} \rtimes_{(m,n)} \mathbb{R}^2$. In this context we have that $(\mathbb{R} \rtimes_m \mathbb{R}) \rtimes (\mathbb{R} \rtimes_n \mathbb{R}) = \mathbb{R} \rtimes_{(m,n)} \mathbb{R}^2$. The natural next step, is to consider which Lie group can be taken as a component in a horospherical product.

A **Heintze group** is a Lie group of the form $\mathbb{R} \rtimes_A N$ with N a nilpotent Lie group, and where all eigenvalues of A have positive real part. Heintze proved in [\[20\]](#) that any simply connected, negatively

curved Lie group is isomorphic to a Heintze group.

Moreover, a Busemann metric space is simply connected, hence any Gromov hyperbolic, Busemann Lie group is isomorphic to a Heintze group. Consequently, Heintze groups are natural candidates for the two components from which a horospherical product is constructed. Let $\mathbb{R} \ltimes_{A_1} N_1$ and $\mathbb{R} \ltimes_{A_2} N_2$ be two Heintze groups, we have

$$(\mathbb{R} \ltimes_{A_1} N_1) \rtimes (\mathbb{R} \ltimes_{A_2} N_2) = \mathbb{R} \ltimes_{\text{Diag}(A_1, -A_2)} (N_1 \times N_2),$$

where $\text{Diag}(A_1, -A_2)$ is the block diagonal matrix containing A_1 and $-A_2$ on its diagonal.

In his paper [29], Xie classifies the subfamily of all negatively curved Lie groups $\mathbb{R} \ltimes \mathbb{R}^n$ up to quasi-isometry. In Chapter 10, we provide a description of the quasi-isometry group of the horospherical product of two Heintze groups, namely the solvable Lie groups $\mathbb{R} \ltimes_{\text{Diag}(A_1, -A_2)} (N_1 \times N_2)$.

1.2.4 Quasi-isometry classification and rigidity results

The description of QI groups of classical horospherical products played a crucial role to obtain a QI classification of some families of metric spaces. Farb and Mosher obtained it for the Baumslag-Solitar groups $\text{BS}(1, p)$.

Theorem. [12] *Farb, Mosher, Theorem 7.1]*

Given integers $m, n \geq 2$, the groups $\text{BS}(1, m)$ and $\text{BS}(1, n)$ are quasi-isometric if and only if they are commensurable. This happens if and only if there exist integers $r, j, k > 0$ such that $m = r^j$ and $n = r^k$.

Then Eskin, Fisher and Whyte obtained a similar result for horospherical products of trees or hyperbolic planes.

Theorem. [10] *Eskin, Fisher, Whyte, Theorem 1.3][11]*

The group $\text{Sol}(m, n)$ is quasi-isometric to $\text{Sol}(m', n')$ if and only if $m'/m = n'/n$.

Theorem. [10] *Eskin, Fisher, Whyte, Theorem 1.5][11]*

The metric space $T_m \rtimes T_n$ is quasi-isometric to $T_{m'} \rtimes T_{n'}$ if and only if m and m' are powers of a common integer, n and n' are powers of a common integer, and $\log m'/\log m = \log n'/\log n$.

This result also permitted to answer a question ask by Woess in [25]. Soardi, Woess] "Is there a vertex-transitive graph that is not quasi-isometric with some Cayley graph?". Eskin, Fisher and Whyte showed that when m and n are coprime integers, $T_m \rtimes T_n$ are such graphs. The geometry of horospherical products is crucial in the work of Eskin, Fisher and Whyte, and their proof holds in the context of either Cayley graphs or Lie groups.

Throughout papers [23] Peng], [24] Peng] and [7] Dymarz], using similar methods, Peng and Dymarz generalized the description of the quasi-isometries for Lie groups of the form $\mathbb{R} \ltimes \mathbb{R}^p$.

Theorem. [7] *Dymarz, Theorem 1]* *Suppose M is a diagonalizable matrix with $\det M = 1$ and no eigenvalues on the unit circle. Let $G_M = \mathbb{R} \ltimes_M \mathbb{R}^n$. If Γ is a finitely generated group quasi-isometric to G_M then Γ is virtually a lattice in $\mathbb{R} \ltimes_{M'} \mathbb{R}^n$ where M' is a matrix that has the same absolute Jordan form as M^α for some $\alpha \in \mathbb{R}$.*

In [23] and [24], Peng provided a description of the quasi-isometry group of Lie groups of the form $\mathbb{R}^m \ltimes \mathbb{R}^n$ as a product of Bi-Lipschitz groups.

The main goal of part II is to generalize the methods and techniques developed by Eskin Fisher and Whyte to a wider set of horospherical products. For this, the space X and Y have to be endowed with appropriate measures.

1.2.5 Admissible measures

In order to generalize the proof of Eskin, Fisher and Whyte developed in [10] and [11], the horospherical products have to be equipped with appropriate measures. For this reason, in the second part of this manuscript, the hyperbolic spaces X and Y are not only metric spaces, but measured metric spaces. Let us first provide a notation for a disk on a horosphere and for projections along vertical geodesics on horospheres.

Notation 1.2.2. *Let X be a Gromov hyperbolic, Busemann, geodesically complete and proper metric space. For all $U \subset X$, $x \in X$ and $z \in \mathbb{R}$:*

1. $U_z := U \cap h^{-1}(z)$ is the intersection of U with the horosphere at height z .
2. $D_r(x) := \{p \in X \mid h(p) = h(x) \text{ and } d^X(x, p) \leq r\} = \mathcal{N}_r(x) \cap (X \cap h^{-1}(h(x)))$ is the ball of center x and radius r on the horosphere at height $h(x)$.
3. $\pi_z(U) := \{p \in h^{-1}(z) \mid \exists V \text{ a vertical ray such that } p \in V, U \cap V \neq \emptyset\}$ is the set of points at height z , linked to U by a vertical geodesic.

We may think of π_z as a projection of U onto the level-set $h^{-1}(z)$, but we point out that $\pi_z(x)$ is not necessarily a point as there may be several vertical geodesics containing x .

Let X be a Gromov hyperbolic, Busemann, geodesically complete and proper metric space. We detail here the additional measure-related assumptions on X we use to obtain the geometric rigidity of the self quasi-isometries of a horospherical product.

Definition 1.2.3. *(Admissible horopointed measured metric spaces.)*

Let $a \in \partial X$ be a point on the Gromov boundary of X . A Borel measure μ^X on X will be said (X, a) horo-admissible if and only if the following (E1), (E2) and (E3) are satisfied.

(E1) *There exists a direction $a \in \partial X$ such that μ^X is desintegrable along the height function h_a :*

For all $z \in \mathbb{R}$, there exist a Borel measure μ_z^X on X_z such that for any measurable set $A \subset X$:

$$\mu^X(A) = \int_{z \in \mathbb{R}} \mu_z^X(A_z) dz$$

(E2) *There exist an appropriate radius M_0 , and uniform constant $C \geq 1$ such that $\forall x_1, x_2 \in X$ we have:*

$$C^{-1} \mu_{h(x_2)}^X(D_{M_0}(x_2)) \leq \mu_{h(x_1)}^X(D_{M_0}(x_1)) \leq C \mu_{h(x_2)}^X(D_{M_0}(x_2))$$

(E3) *There exist $m > 0$ and $C' \geq 1$ such that for all $z_0 \in \mathbb{R}$, and for all measurable set $U \subset X_{z_0}$, and for all $z \leq z_0$:*

$$(C')^{-1} \mu_z^X(\pi_z(U)) \leq e^{m(z_0-z)} \mu_{z_0}^X(U) \leq C' \mu_z^X(\pi_z(U))$$

Such a space (X, a, d, μ^X) will be called a horopointed admissible metric measured space, or just admissible.

By an appropriate radius M_0 , we mean that (E2) should hold for at least one value $M_0 \geq 288\delta$. If this is the case, we will show (Lemma 8.1.2) that assumption (E2) holds for any $M \geq M_0$. Since we are interested only in large scale geometry, it is not important for us whether such property holds at small scales.

Briefly speaking, assumption (E1) allows us to decompose the measure of X on its horospheres, assumption (E2) provides us with a bounded geometry on horospheres and (E3) ensures an exponential contraction of the horospheres' measures in the upward direction.

Let (X, a^X, d^X, μ^X) and (Y, a^Y, d^Y, μ^Y) be two horopointed admissible metric measured spaces. We endow $X \rtimes Y$ with the measure

$$\mu_{\rtimes} := \int_{\mathbb{R}} \mu_z^X \otimes \mu_z^Y dz,$$

see Chapter 8 for details. If the constants involved in assumption (E3), m for X and n for Y , are different, we obtain a geometric description of a self-quasi-isometry of $X \rtimes Y$.

1.3 Results of this thesis

Our main results on horospherical products are of two types, giving rise to two separate articles to be submitted for publication. The first one focuses on the coarse description of distances, geodesics and the visual boundary of them. The second one presents the results regarding the rigidity of the self quasi-isometries of a horospherical product. It also gives the description of their quasi-isometry group in the Lie group context.

1.3.1 Geodesics and visual boundary

There are many possible choices for the distance on $X \rtimes Y$. In this manuscript we work with a family of length path metrics induced by distances on $X \times Y$ (see precise definition 4.1.2). We require that the distance on $X \rtimes Y$ comes from a norm N on \mathbb{R}^2 that is greater than the normalised ℓ_1 norm. Such distances are called admissible. Our first result describes admissible distances.

Theorem A. *Let d_{\rtimes} be an admissible distance on $X \rtimes Y$. Then there exists a constant M depending only on the metric spaces $(X \rtimes Y, d_{\rtimes})$ such that for all $p = (p^X, p^Y), q = (q^X, q^Y) \in X \rtimes Y$:*

$$\left| d_{\rtimes}(p, q) - \left(d^X(p^X, q^X) + d^Y(p^Y, q^Y) - |h(p) - h(q)| \right) \right| \leq M.$$

Hence, given two admissible distances d and d' , the horospherical products $(X \rtimes Y, d)$ and $(X \rtimes Y, d')$ are roughly isometric, which means there exists a $(1, c)$ -quasi-isometry between them, with $c \geq 0$.

For the Sol geometry, M.Troyanov presented in [26] a precise description of minimal geodesics (*ie*: local geodesic for the Riemannian metric) and of the visual boundary of Sol. In the first part of this manuscript, we provide a coarse description of the global geodesics, and of the visual boundary of a broad family of horospherical products. In the case of Sol, we recover, up to an additive constant, Troyanov's description of global geodesics, and we provide the same characterisation of the visual boundary.

Following the characterisation of the distances on horospherical products, we describe the shape of geodesic segments.

Theorem B. *Let X and Y be two proper, geodesically complete, δ -hyperbolic, Busemann spaces and let d_{\rtimes} be an admissible distance on $X \rtimes Y$. Let $p = (p^X, p^Y)$ and $q = (q^X, q^Y)$ be two points of $X \rtimes Y$ and let α be a geodesic segment of $(X \rtimes Y, d_{\rtimes})$ linking p to q . There exists a constant M depending only on $(X \rtimes Y, d_{\rtimes})$, and there exist two vertical geodesics $V_1 = (V_1^X, V_1^Y)$ and $V_2 = (V_2^X, V_2^Y)$ such that:*

1. If $h(p) \leq h(q) - M$ then α is in the M -neighbourhood of $V_1 \cup (V_1^X, V_2^Y) \cup V_2$
2. If $h(p) \geq h(q) + M$ then α is in the M -neighbourhood of $V_1 \cup (V_2^X, V_1^Y) \cup V_2$
3. If $|h(p) - h(q)| \leq M$ then at least one of the conclusions of 1. or 2. holds.

Specifically, V_1 and V_2 can be chosen such that p is close to V_1 and q is close to V_2 .

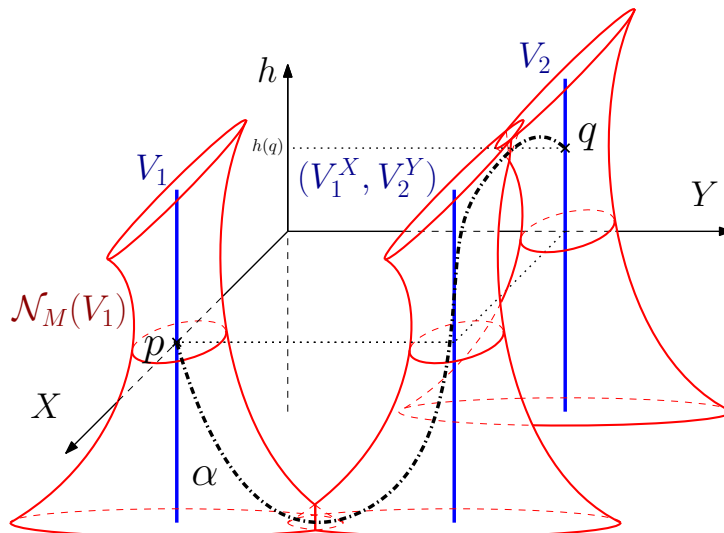

Figure 1.3: Shape of geodesic segments when $h(p) \leq h(q) - \kappa$ in $X \rtimes Y$. The neighbourhoods' shape are distorted since when going upward, distances are contracted in the "direction" X and expanded in the "direction" Y .

An example is illustrated on Figure 1.3 for $h(p) \leq h(q) - \kappa$. Coarsely speaking, Theorem B ensures that any geodesic segment is constructed as the concatenation of three vertical geodesics. This result is similar to the Gromov hyperbolic case, where a geodesic segment is in the constant neighbourhood of two vertical geodesics.

The heuristic comprehension of Theorem B in the case $h(x) \leq h(y) - \kappa$, is that a geodesic segment travels first along an embedded copy of Y (which is upside down) as a geodesic in it, and afterwards travels along an embedded copy of X as a geodesic in it. This result leads us to the existence of unextendable geodesics, which are called dead-ends. This was already well-known for geodesics in lamplighter groups.

Consequently to the description of geodesic segments, we obtain that for any geodesic ray k of $X \rtimes Y$, there exists a vertical geodesic ray at finite distance. Therefore we classify all possible shapes for geodesic rays and then give a description of the visual boundary of $X \rtimes Y$.

A geodesic is called X -type, respectively Y -type, if it is included in a constant M -neighbourhood of geodesics in an embedded copy $X \rtimes V^Y$ of X in $X \rtimes Y$, respectively in an embedded copy $V^X \rtimes Y$ of Y in $X \rtimes Y$, (see Definition 5.3.5 and Figure 1.4). We show that the geodesic lines of $X \rtimes Y$ are either X -type, Y -type or both.

Corollary B.1. *Let X and Y be two proper, geodesically complete, δ -hyperbolic, Busemann spaces. Then there exists $M \geq 0$ depending only on δ such that for all geodesic line $\alpha : \mathbb{R} \rightarrow X \rtimes Y$ at least one of the two following statements holds.*

1. α is a X -type geodesic at scale M of $X \rtimes Y$
2. α is a Y -type geodesic at scale M of $X \rtimes Y$

If a geodesic is both X -type and Y -type at scale M , it is in the M -neighbourhood of a vertical geodesic of $X \rtimes Y$.

Let $o \in X \rtimes Y$, the visual boundary of $X \rtimes Y$, with respect to the base point o , is denoted by $\partial_o(X \rtimes Y)$ and stands for the set of equivalence classes of geodesic rays starting at o . We have:

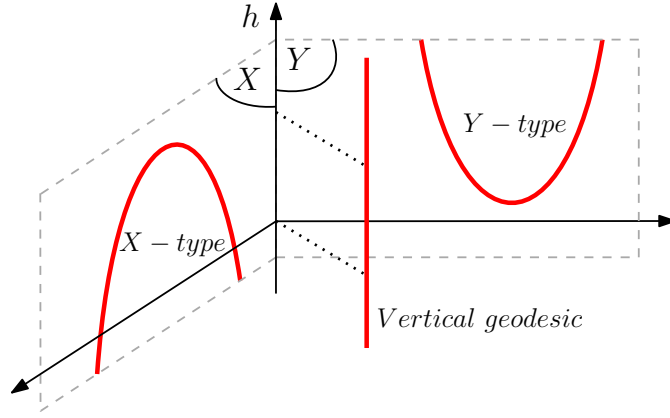

Figure 1.4: Different type of geodesics in $X \rtimes Y$.

Theorem C. *Let X and Y be two proper, geodesically complete, δ -hyperbolic, Busemann spaces. We fix base points and directions on X and Y as follows, $(w^X, a^X) \in X \times \partial X$, $(w^Y, a^Y) \in Y \times \partial Y$. Let $X \rtimes Y$ be the horospherical product with respect to (w^X, a^X) and (w^Y, a^Y) . Then the visual boundary of $X \rtimes Y$ with respect to any point $o = (o^X, o^Y)$ is:*

$$\begin{aligned} \partial_o(X \rtimes Y) &= ((\partial X \setminus \{a^X\}) \times \{a^Y\}) \cup (\{a^X\} \times (\partial Y \setminus \{a^Y\})) \\ &= ((\partial X \times \{a^Y\}) \cup (\{a^X\} \times \partial Y)) \setminus \{(a^X, a^Y)\} \end{aligned}$$

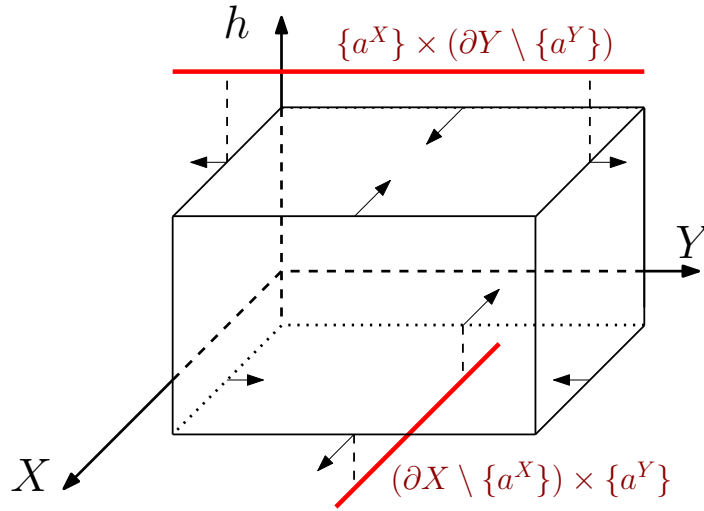

Figure 1.5: Depiction of $\partial_o(X \rtimes Y)$.

This last result is similar to Proposition 6.4 of [26, Troyanov]. However, unlike Troyanov in his work, we are focusing on minimal geodesics and not on local ones. One can see that this visual boundary neither depends on the chosen admissible distance d nor on the base point o .

1.3.2 Geometric description of quasi-isometries

To study the quasi-isometry rigidity of horospherical products, we need to refine the metric tools we developed in part I and to incorporate admissible measures. The main idea is that, along the vertical flow, the measure on horospheres is exponentially distorted, and since a quasi-isometry "quasi-preserved" the volume, it cannot alter the vertical direction.

To be more precise let X and Y be two horo-pointed measured metric spaces. Let us consider their horospherical product $X \rtimes Y$ and let Φ be a self quasi-isometry of $X \rtimes Y$. Then Φ is called a **product map**, if and only if there exists a map Φ^X and a map Φ^Y such that for all $(x, y) \in X \rtimes Y$ we have either:

$$\begin{aligned} \Phi(x, y) &= (\Phi^X(x), \Phi^Y(y)) \\ \text{or } \Phi(x, y) &= (\Phi^Y(y), \Phi^X(x)) \end{aligned}$$

Note that in the first case $\Phi^X : X \rightarrow X$ and in the second case $\Phi^X : X \rightarrow Y$. In particular it implies that Φ^X and Φ^Y are **height respecting** (ie. $\forall x, x' \in X$ such that $h(x) = h(x')$ we have $h(\Phi^X(x)) = h(\Phi^X(x'))$), for Φ to be well defined on $X \rtimes Y$. Moreover, any product map of height respecting quasi-isometries (Φ^X, Φ^Y) is a quasi-isometry of $X \rtimes Y$ (it follows from Theorem [A](#)). Our main theorem in Part II states that, when $m \neq n$, any self quasi-isometries of $X \rtimes Y$ is close to a product map of quasi-isometries.

Theorem D (Geometric rigidity).

Let X and Y be two horo-pointed measured metric spaces with $m > n$. Let Φ a self quasi-isometry of $X \rtimes Y$, then there exist two heigh-respecting quasi-isometries $\Phi^X : X \rightarrow X$ and $\Phi^Y : Y \rightarrow Y$ such that:

$$d_{\rtimes}(\Phi, (\Phi^X, \Phi^Y)) < +\infty$$

In particular, Φ is close to a height respecting map.

The goal of the second part of this doctoral dissertation is to provide the proof of this Theorem. The first step consists in a description of a specific configuration of four points of $X \rtimes Y$ linked by vertical geodesic segments, which are called coarse vertical quadrilateral. In Lemma [7.3.2](#) we show that in such a configuration, two points almost share the same X -coordinate and the two other almost share the same Y -coordinate.

Let us consider Φ a self quasi-isometry of $X \rtimes Y$. Then, using the coarse differentiation method developed by Eskin, Fisher and Whyte, we are able to provide a suitable scale R for Φ , such that almost all vertical geodesic segments of length R are sent close to vertical geodesic segments by Φ .

To make use of this suitable scale, we tile $X \rtimes Y$ with **boxes**. We first define **boxes** at scale R denoted by \mathcal{B}^X , respectively by \mathcal{B}^Y , in X , respectively in Y . Let $z_0 \in \mathbb{R}$ and let $\mathcal{C} \subset X_{z_0}$ be a cell such that $D_{\mathcal{C}} \subset \mathcal{C} \subset D_{2\mathcal{C}}$, with \mathcal{C} a uniform constant to be determined later. A box $\mathcal{B}^X(\mathcal{C}) \subset X$ at scale R , constructed from a cell \mathcal{C} , is defined by:

$$\mathcal{B}^X(\mathcal{C}) := \bigcup_{z \in [z_0 - R; z_0[} \pi_z^X(\mathcal{C}).$$

This means that a point x is in the box $\mathcal{B}^X(\mathcal{C})$ if its height is in $[z_0 - R, z_0[$ and if there is a vertical geodesic from x to \mathcal{C} .

Then a box \mathcal{B} of $X \rtimes Y$ is defined as the horospherical product $\mathcal{B} := \mathcal{B}^X \rtimes \mathcal{B}^Y$ (pictured on Figure [1.6](#)) of two boxes. Given R , the spaces X and Y can easily be tiled by boxes at scale R . The product tiling of $X \times Y$ restricted to $X \rtimes Y$ gives a tiling of $X \rtimes Y$ by boxes of the form $\mathcal{B} = \mathcal{B}^X \rtimes \mathcal{B}^Y$.

From there, we show that, in almost all boxes \mathcal{B} at scale R , the images by Φ of almost all vertical geodesic segments are close to vertical geodesic segments. Hence, a coarse vertical quadrilateral is sent close to a coarse vertical quadrilateral, on which we use the aforementioned Lemma [7.3.2](#) to prove that Φ is close to a product map on the box \mathcal{B} .

Then, for a bigger scale $L \gg R$, we tile a box at scale L with boxes at scale R . Thanks to the assumption $m > n$, we manage to unify the previously obtained quasi-isometry products on most of the boxes at scale R in order to obtain a quasi-isometry product on the box at scale L . Hence, we prove that the quasi-isometry Φ is close to a product map on all boxes at scale L . Afterwards, we extend this product map construction on the whole space.

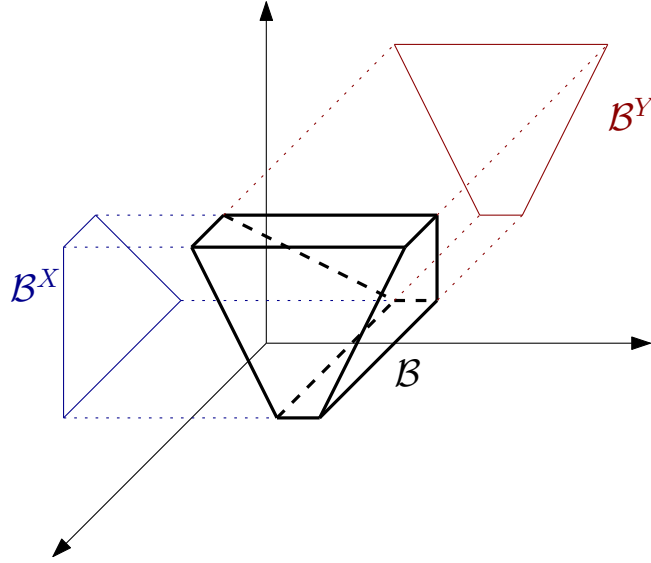
Figure 1.6: Box in $X \times Y$

Remark 1.3.1. A major technical issue in this proof is to manage the notion of "almost all" vertical geodesic segments having a certain property. The desintegrable measure μ of assumption (E1) is not suited for this role since it concentrates the measure of a box on its bottom part. Therefore we introduce another desintegrable measure λ , constructed from μ , which (almost) equally weights the level-sets of the height function h in boxes.

This measure λ^X , together with a similar λ^Y , permits to define properly a measure (later denoted η) on the family of vertical geodesics contained in a box B .

When we understand the boundaries of X and Y , Theorem [D](#) permits to give a description of the quasi-isometry-group of $X \times Y$. In the last chapter of this dissertation, we detail such a description for the horospherical product of two Heintze groups.

Let $\mathbb{R} \times_{A_1} N_1$ and $\mathbb{R} \times_{A_2} N_2$ be two Heintze groups, in Chapter [10](#) we show that this couple of Heintze group is admissible, and that the condition $m \neq n$ is equivalent to $tr(A_1) \neq tr(A_2)$. Hence we apply our main results, and with a small refining on quasi-isometries structure, we obtain the following characterisation of the quasi-isometry group of the solvable Lie groups $\mathbb{R} \times_{\text{Diag}(A_1, -A_2)} (N_1 \times N_2)$.

Recall that for F a metric space, $\text{QI}(F)/\sim$ is the group of self quasi-isometry of F , up to finite distance. (This equivalence relation is required since a quasi-isometry only has a coarse inverse.) Recall also that $\text{Bilip}(F)$ stands for the group of self bi-Lipschitz maps of F . Then we have:

Theorem E. If $tr(A_1) \neq tr(A_2)$:

$$\text{QI}(\mathbb{R} \times_{\text{Diag}(A_1, -A_2)} (N_1 \times N_2)) / \sim = \text{Bilip}(N_1) \times \text{Bilip}(N_2) \quad (1.1)$$

We know that, if two spaces E and F are quasi-isometric, their respective quasi-isometry group are isomorphic. Consequently, if the descriptions we provided are different, E and F are not quasi-isometric.

1.4 Possible further developments

This work takes place in a program of QI classification of solvable Lie groups suggested by Eskin and Fisher in [\[8\]](#). Our understanding of this topic could be further developed in several ways. First, the methods developed by Irene Peng in [\[23\]](#) could potentially adapt in the horospherical product of two

Heintze groups $\mathbb{R} \times N_1$ and $\mathbb{R} \times N_2$, which would provide us with a characterisation of $\text{QI}(\mathbb{R}^p \times (N_1 \times N_2))$, a much broader family of solvable Lie groups.

With a deep understanding on the bi-Lipschitz application groups involved, it would be a step forward in the quasi-isometry classification of solvable Lie groups.

Secondly, we only treated the case $m \neq n$ in our main theorems, which follows ideas of [10]. The case $m = n$, which contains a lot of interesting examples, is much harder. Following the ideas of [11] for the horospherical product of two horopointed metric spaces might provide the wanted generalisation.

A possible direction is the geometric study of multiple horospherical product such as $\{(x, y, z) \in X \times Y \times Z \mid h_X(x) + h_Y(y) + h_Z(z) = 0\}$. Such horospherical products of trees have already been studied in [1]. The techniques developed for the study of geodesic and virtual boundary, with some adaptations, might hold in this wider context.

Another development would be to remove the Busemann assumption. This assumption is not verified by finitely generated groups (other than free groups), and a description of some of their quasi-isometry group would be interesting in the view of their quasi-isometry classification. The Busemann assumption make the proofs less technical, which is appreciable since the proof are already quite technical. The generalisation would follow the same ideas, with an additional layer of coarse convexity. However even connectedness of a horospherical product is unclear without the Busemann assumption.

1.5 Structure of the manuscript

This thesis is divided into two major parts. Here is a framework of the first part, devoted to geodesics and visual boundary.

- In Chapter 3 present an estimate on the length of paths avoiding horoballs in hyperbolic spaces, namely Lemma 3.2.5 which will be central in our control of the distances on $X \rtimes Y$.
- In Chapter 4 we define the horospherical products and give an estimate of their distance through Theorem 4.3.4
- Last, in Chapter 5, we prove the main results of Part I. Theorem A follows from Corollary 4.3.4. The description of geodesic lines of Theorem B follows from Theorem A and gives us the tools to prove Theorem C.

The second part, about geometric rigidity of self quasi-isometries, is summarized as followed.

- In Chapter 7 we generalize methods presented by Eskin, Fisher and Whyte. In particular we display the coarse differentiation in our context, and we discuss particular quadrilateral configurations of $X \rtimes Y$.
- Chapter 8 focuses on developing all the measure theoretical tools required to achieve the rigidity results.
- Then, in Chapter 9, we follow the structure of the proof proposed by Eskin, Fisher and Whyte in [10], invoking technical Lemmas of previous chapters when required.
- In the last Chapter we present an application of our theorem by providing a description of the quasi-isometry group of a family of solvable Lie groups.

Part I

Geodesic and visual boundary of horospherical product

Chapter 2

Context

2.1 Gromov hyperbolic spaces

The goal of this section is to recall what is a Gromov hyperbolic space and what are vertical geodesics in such a space. Let H be a proper geodesic metric space, and d be a distance on H . A geodesic line, respectively ray, segment, of H is the isometric image of a Euclidean line, respectively half Euclidean line, interval, in H . By slight abuse, we may call geodesic, geodesic ray or geodesic segment, the map $\alpha : I \rightarrow H$ itself, which parametrises our given geodesic by arclength.

Let $\delta \geq 0$ be a non-negative number. Let x, y and z be three points of H . The geodesic triangle $[x, y] \cup [y, z] \cup [z, x]$ is called δ -slim if any of its sides is included in the δ -neighbourhood of the remaining two. The metric space H is called δ -hyperbolic if every geodesic triangle is δ -slim. A metric space H is called Gromov hyperbolic if there exists $\delta \geq 0$ such that H is a δ -hyperbolic space.

An important property of Gromov hyperbolic spaces is that they admit a nice compactification thanks to their *Gromov boundary*. We call two geodesic rays of H equivalent if their images are at finite Hausdorff distance. Let $w \in H$ be a base point. We define $\partial_w H$ the Gromov boundary of H as the set of families of equivalent rays starting from w . The boundary $\partial_w H$ does not depend on the base point w , hence we will simply denote it by ∂H . Both ∂H and $H \cup \partial H$, are compact endowed with the Hausdorff topology. For more details, see [16] Ghys, De La Harpe] or chap.III H. p.399 of [3] Bridson, Haefliger].

2.2 Vertical geodesics with respect to a boundary point

In this section we fix $\delta \geq 0$, H a proper, geodesic, δ -hyperbolic space, $w \in H$ a base point and $a \in \partial H$ a point on the boundary of H . We recall the definition of the Busemann function with respect to a and w .

$$\forall x \in H, \beta_a(x, w) = \sup \{ \limsup_{t \rightarrow +\infty} (d(x, k(t)) - t) \mid k \in a, \text{ starting from } w \}.$$

We define the height on H as the opposite of the Busemann function.

Definition 2.2.1 (height with respect to $a \in \partial H$ and $w \in H$). *Let $a \in \partial H$ be a direction in H and let $w \in H$ be a base point. Then we define:*

$$\forall x \in H, \quad h_{(a,w)}(x) = -\beta_a(x, w).$$

Let us write Proposition 2 chap.8 p.136 of [16] Ghys, De La Harpe] with our notations.

Proposition 2.2.2 ([16], chap.8 p.136). *Let H be a hyperbolic proper geodesic metric space. Let $a \in \partial H$ and $w \in H$, then:*

1. $\lim_{x \rightarrow a} h_{(a,w)}(x) = +\infty$
2. $\lim_{x \rightarrow b} h_{(a,w)}(x) = -\infty, \forall b \in \partial H \setminus \{a\}$
3. $\forall x, y, z \in H, |\beta_a(x, y) + \beta_a(y, z) - \beta_a(x, z)| \leq 200\delta$.

Furthermore, a geodesic ray is in $a \in \partial H$ if and only if its height tends to $+\infty$.

Corollary 2.2.3. *Let H be a hyperbolic proper geodesic metric space. Let $a \in \partial H$ and $w \in H$, and let $\alpha : [0, +\infty[\rightarrow H$ be a geodesic ray. The two following properties are equivalent:*

1. $\lim_{t \rightarrow +\infty} h_{(a,w)}(\alpha(t)) = +\infty$
2. $\alpha([0, +\infty[) \in a$.

Proof. As for any geodesic ray $\alpha : [0, +\infty[\rightarrow H$ there exists $b \in \partial H$ such that $\alpha([0, +\infty[) \in b$, this proposition is a particular case of Proposition [2.2.2](#) \square

We will picture our hyperbolic spaces in a way similar to the Log model for the hyperbolic plane. We send $a \in \partial H$ upward to infinity and $\partial H \setminus \{a\}$ downward to infinity. We then call vertical the geodesic rays that are in the equivalence class a .

Definition 2.2.4 (Vertical geodesics with respect to $a \in \partial H$). *A geodesic of H which satisfies one of the properties of Corollary [2.2.3](#) is called a vertical geodesic relatively to the point a .*

An important property of the height function is to be Lipschitz.

Proposition 2.2.5. *Let $a \in \partial H$ and $w \in H$. The height function $h_a := -\beta_a(\cdot, w)$ is Lipschitz:*

$$\forall x, y \in H, |h_{(a,w)}(x) - h_{(a,w)}(y)| \leq d(x, y).$$

Proof. By using the triangle inequality we have for all $x, y \in H$:

$$\begin{aligned} -h_{(a,w)}(x) &= \beta_a(x, w) = \sup\{\limsup_{t \rightarrow +\infty} (d(x, k(t)) - t) \mid k \text{ vertical rays starting at } w\} \\ &\leq d(x, y) + \sup\{\limsup_{t \rightarrow +\infty} (d(y, k(t)) - t) \mid k \text{ vertical rays starting at } w\} \\ &\leq d(x, y) + \beta_a(y, w) \leq d(x, y) - h_{(a,w)}(y). \end{aligned}$$

The result follows by exchanging the roles of x and y . \square

From now on, we fix a given $a \in \partial H$ and a given $w \in H$. Therefore we simply denote the height function by h instead of $h_{(a,w)}$.

Proposition 2.2.6. *Let α be a vertical geodesic of H . We have the following control on the height along α :*

$$\forall t_1, t_2 \in \mathbb{R}, t_2 - t_1 - 200\delta \leq h(\alpha(t_2)) - h(\alpha(t_1)) \leq t_2 - t_1 + 200\delta.$$

Proof. Let $t_1, t_2 \in \mathbb{R}$, then:

$$\begin{aligned} h(\alpha(t_2)) - h(\alpha(t_1)) &= \beta(\alpha(t_1), w) - \beta(\alpha(t_2), w) \\ &= \beta(\alpha(t_1), \alpha(t_2)) - \left(\beta(\alpha(t_2), w) - \beta(\alpha(t_1), w) + \beta(\alpha(t_1), \alpha(t_2)) \right). \end{aligned}$$

The third point of Proposition [2.2.2](#) applied to the last bracket gives:

$$\beta(\alpha(t_1), \alpha(t_2)) - 200\delta \leq h(\alpha(t_2)) - h(\alpha(t_1)) \leq \beta(\alpha(t_1), \alpha(t_2)) + 200\delta. \quad (2.1)$$

Since $t \mapsto \alpha(t + t_2)$ is a vertical geodesic starting at $\alpha(t_2)$ we have:

$$\begin{aligned} \beta(\alpha(t_1), \alpha(t_2)) &= \sup \left\{ \limsup_{t \rightarrow +\infty} (d(\alpha(t_1), k(t)) - t) \mid k \text{ vertical rays starting at } \alpha(t_2) \right\} \\ &\geq \limsup_{t \rightarrow +\infty} (d(\alpha(t_1), \alpha(t + t_2)) - t) \\ &\geq \limsup_{t \rightarrow +\infty} (|t + t_2 - t_1| - t) \geq t_2 - t_1, \text{ for } t \text{ large enough.} \end{aligned}$$

Using this last inequality in inequality (2.1) we get $t_2 - t_1 - 200\delta \leq h(\alpha(t_2)) - h(\alpha(t_1))$. The result follows by exchanging the roles of t_1 and t_2 . \square

Using Proposition 2.2.6 with $t_1 = 0$ and $t_2 = t$, the next corollary holds.

Corollary 2.2.7. *Let α be a vertical geodesic parametrised by arclength and such that $h(\alpha(0)) = 0$. We have:*

$$\forall t \in \mathbb{R}, |h(\alpha(t)) - t| \leq 200\delta.$$

In the sequel we want to apply the slim triangles property on ideal triangles, hence we need the following result of [5] Coornaert, Delzant, Papadopoulos].

Property 2.2.8 (Proposition 2.2 page 19 of [5]). *Let a, b and c be three points of $X \cup \partial X$. Let α, β, γ be three geodesics of X linking respectively b to c , c to a , and a to b . Then every point of α is at distance less than 24δ from the union $\beta \cup \gamma$.*

2.3 Busemann spaces

We recall here some material from Chap.8 and Chap.12 of [22] Papadopoulos] about Busemann spaces. Busemann spaces are metric spaces where the distance between geodesics are convex functions. To make it more precise, a metric space X is called Busemann if it is geodesic, and if for every pair of geodesics segments parametrised by arclength $\gamma : [a, b] \rightarrow X$ and $\gamma' : [a', b'] \rightarrow X$, the following function is convex:

$$\begin{aligned} D_{\gamma, \gamma'} : [a, b] \times [a', b'] &\rightarrow X \\ (t, t') &\mapsto d_X(\gamma(t), \gamma'(t')). \end{aligned}$$

As an example, all CAT(0) spaces are Busemann spaces. However, being CAT(0) is stronger than being Busemann convex by Theorem 1.3 of [15] Foertsch, Lytchak, Schroeder]. As an example, strictly convex Banach spaces are all Busemann spaces, but they are CAT(0) if and only if they are Hilbert spaces. Something interesting in Busemann spaces is that two points are always linked by a unique geodesic (see 8.1.4 p.203 of [22] Papadopoulos] for further details). The next proposition gives us informations on the height functions.

Property 2.3.1 (Prop. 12.1.5 in p.263 of Papadopoulos [22]). *Let $\delta \geq 0$ be a non negative number. Let H be a proper δ -hyperbolic, Busemann space. For every geodesic α , the function $t \mapsto -h(\alpha(t))$ is convex.*

From now on, H will be a proper, Gromov hyperbolic, Busemann space. The Busemann hypothesis implies that the height along geodesic behaves nicely. This means that we can drop the constant 200δ from Corollary 2.2.7. It is the main reason why we require our spaces to be Busemann spaces.

Proposition 2.3.2. *Let H be a δ -hyperbolic and Busemann space and let $V : \mathbb{R} \rightarrow H$ be a path of H . Then V is a vertical geodesic if and only if $\exists c \in \mathbb{R}$ such that $\forall t \in \mathbb{R}, h(V(t)) = t + c$.*

Proof. Let V be a vertical geodesic in H . By Property [2.3.1](#) we have that $t \mapsto -h(V(t))$ is convex. Furthermore, from Corollary [2.2.7](#), we get $|h(V(t)) - t| \leq 200\delta$. Thereby the bounded convex function $t \mapsto t - h(V(t))$ is constant. Then there exists a real number c such that $\forall t \in \mathbb{R}, h(V(t)) = t + c$. We now assume that there exists a real number c such that $\forall t \in \mathbb{R}, h(V(t)) = t + c$. Therefore, for all real numbers t_1 and t_2 we have $d(V(t_1), V(t_2)) \geq \Delta h(V(t_1), V(t_2)) = |t_1 - t_2|$. By definition V is a connected path, hence $|t_1 - t_2| \geq d(V(t_1), V(t_2))$ which implies with the previous sentence that $|t_1 - t_2| = d(V(t_1), V(t_2))$, then V is a geodesic. Furthermore $\lim_{t \rightarrow +\infty} h(V(t)) = +\infty$, which implies by definition that V is a vertical geodesic. \square

A metric space is called geodesically complete if all its geodesic segments can be prolonged into geodesic lines. By adding the hypothesis of geodesically completeness on a hyperbolic Busemann space H we get that any point of H is included in a vertical geodesic line.

Property 2.3.3. *Let H be a δ -hyperbolic Busemann geodesically complete space. Then for all $x \in H$ there exists a vertical geodesic $V_x : \mathbb{R} \rightarrow H$ such that V_x contains x*

Proof. Let us consider in this proof $w \in H$ and $a \in \partial H$, from which we constructed the height h of our space H . Then by definition we have $h_{(a,w)} = h$. Proposition 12.2.4 of [\[22\]](#) Papadopoulos] ensures the existence of a geodesic ray $R_x \in a$ starting at x . Furthermore as H is geodesically complete R_x can be prolonged into a geodesic $V_x : \mathbb{R} \rightarrow H$ such that $V_x([0; +\infty[) \in a$. Hence V_x is a vertical geodesic from Definition [2.2.4](#). \square

In this section we defined all the objects we will use in hyperbolic spaces. We will now focus on proving length estimates on specific paths. They will appear in Section [4](#) as the projection of geodesics in a horospherical product.

Chapter 3

Metric estimates in Gromov hyperbolic Busemann spaces

3.1 Metric description of geodesics

This section focuses on length estimates in Gromov hyperbolic Busemann spaces. The central result is Proposition 3.2.5, which presents a lower bound on the length of a path staying between two horospheres. Before moving to the technical results of this section, let us introduce some notations.

Notation 3.1.1. *Unless otherwise specified, H will be a Gromov hyperbolic Busemann geodesically complete proper space. Let $\gamma : I \rightarrow H$ be a connected path. Let us denote the maximal height and the minimal height of this path as follows:*

$$h^+(\gamma) = \sup_{t \in I} \{h(\gamma(t))\} \quad ; \quad h^-(\gamma) = \inf_{t \in I} \{h(\gamma(t))\}.$$

Let x and y be two points of H , we denote the height difference between them by:

$$\Delta h(x, y) = |h(x) - h(y)|.$$

We define the relative distance between two points x and y of H as:

$$d_r(x, y) = d(x, y) - \Delta h(x, y).$$

Let us denote V_x a vertical geodesic containing x , we will assume it to be parametrised by arclength. Thanks to Proposition 2.3.2 we choose a parametrisation by arclength such that $\forall t \in \mathbb{R}$, $h(V_x(t)) = t + 0$.

The relative distance between two points quantifies how far a point is from the nearest vertical geodesic containing the other point. Next lemma tells us that in order to connect two points a geodesic needs to go sufficiently high. This height is controlled by the relative distance between those two points.

Lemma 3.1.2. *Let H be a δ -hyperbolic and Busemann metric space, let x and y be two elements of H such that $h(x) \leq h(y)$, and let α be a geodesic linking x to y . Let us denote $z = \alpha(\Delta h(x, y) + \frac{1}{2}d_r(x, y))$, $x_1 := V_x(h(y) + \frac{1}{2}d_r(x, y))$ the point of V_x at height $h(y) + \frac{1}{2}d_r(x, y)$ and $y_1 := V_y(h(y) + \frac{1}{2}d_r(x, y))$ the point of V_y at the same height $h(y) + \frac{1}{2}d_r(x, y)$. Then we have:*

1. $h^+(\alpha) \geq h(y) + \frac{1}{2}d_r(x, y) - 96\delta$
2. $d(z, x_1) \leq 144\delta$
3. $d(z, y_1) \leq 144\delta$
4. $d(x_1, y_1) \leq 288\delta$.

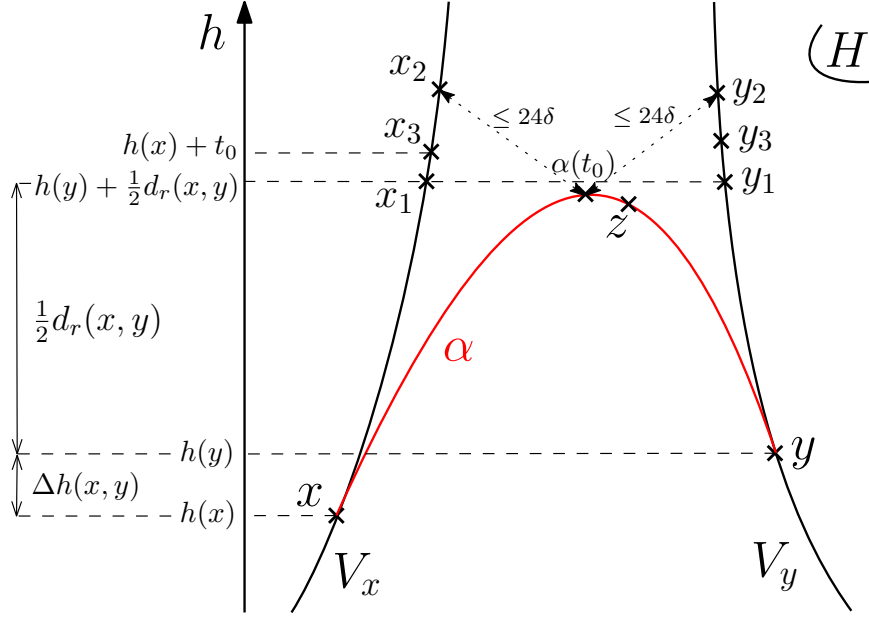

Figure 3.1: Proof of Lemma 3.1.2

Proof. The lemma and its proof are illustrated in Figure 3.1. Following Property 2.2.8, the triple of geodesics α , V_x and V_y is a 24δ -slim triangle. Since the sets $\{t \in [0, d(x, y)] \mid d(\alpha(t), V_x) \leq 24\delta\}$ and $\{t \in [0, d(x, y)] \mid d(\alpha(t), V_y) \leq 24\delta\}$ are closed sets covering $[0, d(x, y)]$, their intersection is non empty. Hence there exists $t_0 \in [0, d(x, y)]$, $x_2 \in V_x$ and $y_2 \in V_y$ such that $d(\alpha(t_0), x_2) \leq 24\delta$ and $d(\alpha(t_0), y_2) \leq 24\delta$. Let us first prove that t_0 is close to $\Delta h(x, y) + \frac{1}{2}d_r(x, y)$. By the triangle inequality we have that:

$$|t_0 - d(x, x_2)| = |d(x, \alpha(t_0)) - d(x, x_2)| \leq d(x_2, \alpha(t_0)) \leq 24\delta.$$

Let us denote $x_3 := V_x(h(x) + t_0)$ the point of V_x at height $h(x) + t_0$, and $y_3 = V_y(h(y) + d(x, y) - t_0)$ the point of V_y at height $h(y) + d(x, y) - t_0$. Then by the triangle inequality:

$$\begin{aligned} d(\alpha(t_0), x_3) &\leq d(\alpha(t_0), x_2) + d(x_2, x_3) = d(\alpha(t_0), x_2) + |d(x, x_2) - d(x, x_3)| \\ &\leq d(\alpha(t_0), x_2) + |d(x, x_2) - t_0| \leq 48\delta. \end{aligned} \quad (3.1)$$

In the last inequality we used that $d(x, x_3) = t_0$, which holds by the definition of x_3 . We show in the same way that $d(\alpha(t_0), y_3) \leq 48\delta$. By the triangle inequality we have $d(x_3, y_3) \leq 96\delta$. As the height function is Lipschitz we have $\Delta h(x_3, y_3) \leq d(x_3, y_3) \leq 96\delta$, which provides us with:

$$\begin{aligned} \left| \frac{1}{2}d_r(x, y) + \Delta h(x, y) - t_0 \right| &= \frac{1}{2} \left| d_r(x, y) + \Delta h(x, y) + h(y) - h(x) - 2t_0 \right| \\ &= \frac{1}{2} |h(y) + d(x, y) - t_0 - (h(x) + t_0)| = \frac{1}{2} \Delta h(x_3, y_3) \leq \frac{96\delta}{2} \leq 48\delta. \end{aligned} \quad (3.2)$$

In particular it gives us that $d(z, \alpha(t_0)) \leq 48\delta$. We are now ready to prove the first point using inequalities (3.1) and (3.2):

$$\begin{aligned} h^+(\alpha) &\geq h(\alpha(t_0)) \geq h(x_3) - \Delta h(\alpha(t_0), x_3) \geq h(x) + t_0 - 48\delta \\ &\geq h(x) + \frac{1}{2}d_r(x, y) + \Delta h(x, y) - 96\delta \geq h(y) + \frac{1}{2}d_r(x, y) - 96\delta, \text{ as we have } h(x) \leq h(y). \end{aligned}$$

The second point of our lemma is proved as follows:

$$\begin{aligned} d(z, x_1) &\leq d(z, \alpha(t_0)) + d(\alpha(t_0), x_1) \leq 48\delta + d(\alpha(t_0), x_3) + d(x_3, x_1) \\ &\leq 96\delta + \left| t_0 + h(x) - \left(\frac{1}{2}d_r(x, y) + h(y) \right) \right| = 96\delta + \left| t_0 - \left(\Delta h(x, y) + \frac{1}{2}d_r(x, y) \right) \right| \leq 144\delta. \end{aligned}$$

The proof of 3. is similar, and 4. is obtained from 2. and 3. by the triangle inequality. \square

The next lemma shows that in the case where $h(x) \leq h(y)$ a geodesic linking x to y is almost vertical until it reaches the height $h(y)$.

Lemma 3.1.3. *Let H be a δ -hyperbolic and Busemann space. Let x and y be two points of H such that $h(x) \leq h(y)$. We define $x' := V_x(h(y))$ to be the point of the vertical geodesic V_x at the same height as y . Then:*

$$|d_r(x, y) - d(x', y)| \leq 54\delta. \quad (3.3)$$

Proof. Since H is δ -hyperbolic, the geodesic triangle $[x, y] \cup [y, x'] \cup [x', x]$ is δ -slim. Then there exists $p_1 \in [x, x']$, $p_2 \in [x', y]$ and $m \in [x, y]$ such that $d(p_1, m) \leq \delta$ and $d(p_2, m) \leq \delta$. Hence, $h^-([x', y]) - \delta \leq h(m) \leq h^+([x, x']) + \delta$. Let $R_{x'}$ and R_y be two vertical geodesic rays respectively contained in V_x and V_y and respectively starting at x' and y . Then Property 2.2.8 used on the ideal triangle $R_x \cup R_y \cup [x', y]$ implies that $h^-([x', y]) \geq h(y) - 24\delta$, therefore we have $h^+([x, x']) = h(y)$. Then $h(y) - 25\delta \leq h(m) \leq h(y) + \delta$ holds. It follows that m and x' are close to each other:

$$\begin{aligned} d(m, x') &\leq d(m, p_1) + d(p_1, x') \leq \delta + \Delta h(p_1, x') \leq \delta + \Delta h(p_1, m) + \Delta h(m, y) + \Delta h(y, x') \\ &\leq \delta + d(p_1, m) + 25\delta + 0 \leq 27\delta. \end{aligned} \quad (3.4)$$

Then we give an estimate on the distance between x and m :

$$|d(x, m) - \Delta h(x, y)| = |d(x, m) - d(x, x')| \leq d(m, x') \leq 27\delta. \quad (3.5)$$

However $d_r(x, y) = d(x, y) - \Delta h(x, y)$ and $d(x, y) = d(x, m) + d(m, y)$, therefore:

$$d_r(x, y) = d(x, m) + d(m, y) - \Delta h(x, y). \quad (3.6)$$

Combining inequalities (3.5) and (3.6) we have $|d_r(x, y) - d(m, y)| \leq 27\delta$. Then:

$$|d_r(x, y) - d(x', y)| \leq 27\delta + d(x', m) \leq 54\delta. \quad \square$$

We are now able to prove the estimates of the next section.

3.2 Length estimate of paths avoiding horospheres

Consider a path γ and a geodesic α sharing the same end-points in a proper, Gromov hyperbolic, Busemann space. We prove in this section that if the height of γ does not reach the maximal height of the geodesic α , then γ is much longer than α . Furthermore, its length increases exponentially with respect to the difference of maximal height between γ and α . To do so, we make use of Proposition 1.6 p400 of [3] Bridson, Haefliger], which we recall here. Let us denote by $l(c)$ the length of a path c .

Proposition 3.2.1 ([3]). *Let X be a δ -hyperbolic geodesic space. Let c be a continuous path in X . If $[p, q]$ is a geodesic segment connecting the endpoints of c , then for every $x \in [p, q]$:*

$$d(x, \text{im}(c)) \leq \delta |\log_2 l(c)| + 1.$$

This result implies that a path of X between p and q which avoids the ball of diameter $[p, q]$ has length greater than an exponential of the distance $d(p, q)$.

From now on we will add as convention that $\delta \geq 1$. For all $\delta_1 \leq \delta_2$ a δ_1 -slim triangle is also δ_2 -slim, hence all δ_1 -hyperbolic spaces are δ_2 -hyperbolic spaces. That is why we can assume that all Gromov hyperbolic spaces are δ -hyperbolic with $\delta \geq 1$. It allows us to consider $\frac{1}{\delta}$ as a well defined term, we hence avoid the arising of separated cases in some of the proofs. We also use this assumption to simplify constants appearing in this document. The next result is a similar control on the length of path as Proposition 3.2.1, but we consider that the path is avoiding a horosphere instead of avoiding a ball in H .

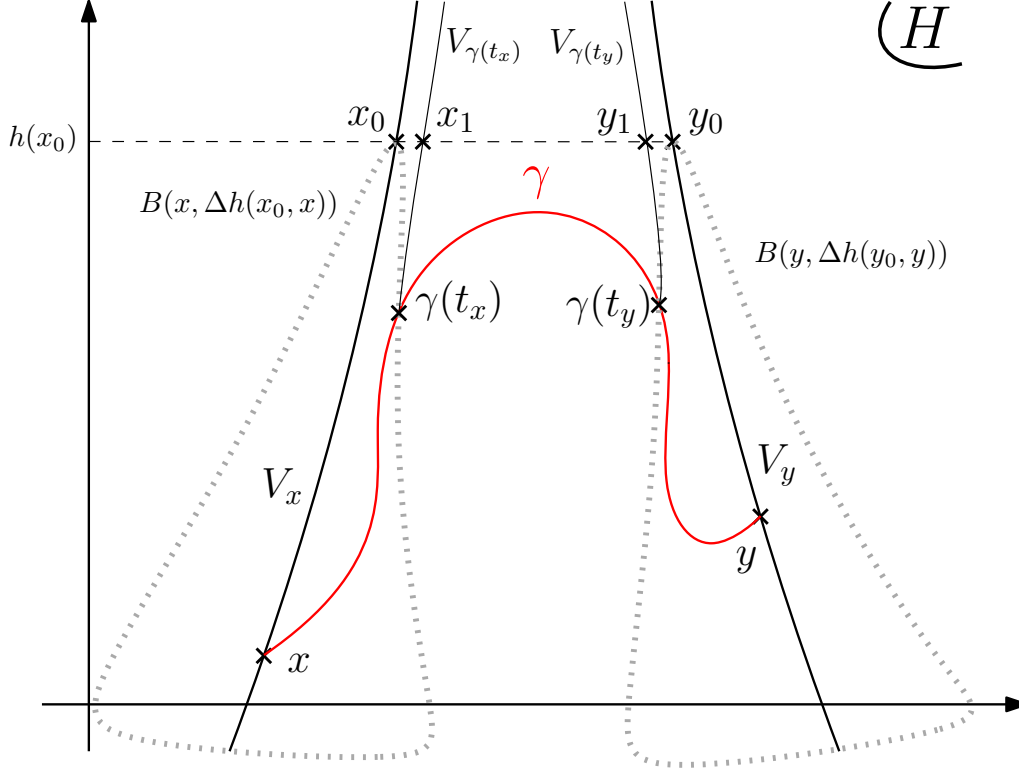

Figure 3.2: Proof of Lemma 3.2.2

Lemma 3.2.2. *Let $\delta \geq 1$ and H be a proper, geodesic, δ -hyperbolic, Busemann space. Let x and $y \in H$ and let V_x , respectively V_y , be a vertical geodesic containing x , respectively y . Let us consider $t_0 \geq \max(h(x), h(y))$ and let us denote $x_0 := V_x(t_0)$ and $y_0 := V_y(t_0)$, the respective points of V_x and V_y at the height t_0 . Assume that $d(x_0, y_0) > 768\delta$.*

Then for all connected path $\gamma : [0, T] \rightarrow H$ such that $\gamma(0) = x$, $\gamma(T) = y$ and $h^+(\gamma) \leq h(x_0)$ we have:

$$l(\gamma) \geq \Delta h(x, x_0) + \Delta h(y, y_0) + 2^{-386} 2^{\frac{1}{2\delta} d(x_0, y_0)} - 24\delta. \quad (3.7)$$

For trees (when $\delta = 0$) this Lemma still makes sense. Indeed, if δ tends to 0 then the length of the path described in this Lemma tends to infinity, which is consistent with the fact that such a path does not exist in trees. The proof would use the fact that in Proposition 3.2.1 we have $d(x, \text{im}(c)) = 0$ when $\delta = 0$ since 0-hyperbolic spaces are real trees.

Proof. One can follow the idea of the proof on Figure 3.2. We will consider γ to be parametrised by arclength. Let $B(x, \Delta h(x_0, x)) \subset H$ be the ball of radius $h(x_0) - h(x)$ centred on x , and let $m \in B(x, \Delta h(x_0, x))$ be a point in this ball. Then:

$$d_r(m, x) = d(m, x) - \Delta h(m, x) \leq \Delta h(x, x_0) - \Delta h(m, x) \leq \Delta h(x_0, m).$$

Let us first assume that $h(m) \geq h(x)$, then:

$$h(m) + \frac{d_r(m, x)}{2} \leq h(m) + \frac{\Delta h(x_0, m)}{2} \leq h(m) + \frac{h(x_0) - h(m)}{2} = \frac{h(x_0)}{2} + \frac{h(m)}{2} \leq h(x_0). \quad (3.8)$$

By Lemma 3.1.2 we have:

$$d\left(V_x\left(h(m) + \frac{d_r(m, x)}{2}\right), V_m\left(h(m) + \frac{d_r(m, x)}{2}\right)\right) \leq 288\delta.$$

We now assume that $h(m) \leq h(x)$, then:

$$h(x) + \frac{d_r(x, m)}{2} \leq h(x) + \frac{d(x, m)}{2} \leq h(x) + \frac{\Delta h(x, x_0)}{2} \leq h(x_0).$$

Then Lemma 3.1.2 provides us with:

$$d\left(V_x\left(h(x) + \frac{d_r(m, x)}{2}\right), V_m\left(h(x) + \frac{d_r(m, x)}{2}\right)\right) \leq 288\delta.$$

Since H is a Busemann space, the function $t \rightarrow d(V_x(t), V_m(t))$ is convex. Furthermore $t \rightarrow d(V_x(t), V_m(t))$ is bounded on $[0; +\infty[$ as H is Gromov hyperbolic, hence $t \rightarrow d(V_x(t), V_m(t))$ is a non increasing function. Therefore both cases $h(m) \leq h(x)$ and $h(x) \leq h(m)$ give us that:

$$d\left(x_0, V_m(h(x_0))\right) = d\left(V_x(h(x_0)), V_m(h(x_0))\right) \leq 288\delta. \quad (3.9)$$

In other words, all points of $B(x, \Delta h(x_0, x))$ belong to a vertical geodesic passing nearby x_0 . By the same reasoning we have $\forall n \in B(y, \Delta h(y_0, y))$:

$$d\left(y_0, V_n(h(y_0))\right) \leq 288\delta. \quad (3.10)$$

Then by the triangle inequality:

$$\begin{aligned} d\left(V_m(h(x_0)), V_n(h(y_0))\right) &\geq -d\left(x_0, V_m(h(x_0))\right) + d(x_0, y_0) - d\left(y_0, V_n(h(y_0))\right) \\ &\geq 768\delta - 288\delta - 288\delta \geq 192\delta. \end{aligned} \quad (3.11)$$

Specifically $d(V_m(h(x_0)), V_n(h(y_0))) = d(V_m(h(x_0)), V_n(h(x_0))) > 0$ which implies that $m \neq n$. Then $B(x, \Delta h(x_0, x)) \cap B(y, \Delta h(y_0, y)) = \emptyset$. By continuity of γ we deduce the existence of the two following times $t_x \leq t_y$ such that:

$$\begin{aligned} t_x &= \inf\{t \in [0, T] \mid d(\gamma(t), x) = \Delta h(x, x_0)\}, \\ t_y &= \sup\{t \in [0, T] \mid d(\gamma(t), y) = \Delta h(y, y_0)\}. \end{aligned}$$

In order to have a lower bound on the length of γ we will need to split this path into three parts:

$$\gamma = \gamma|_{[0, t_x]} \cup \gamma|_{[t_x, t_y]} \cup \gamma|_{[t_y, T]}.$$

As γ is parametrised by arclength and $d(\gamma(0), \gamma(t_x)) = \Delta h(x, x_0)$ we have that:

$$l\left(\gamma|_{[0, t_x]}\right) \geq \Delta h(x, x_0). \quad (3.12)$$

For similar reasons we also have:

$$l\left(\gamma|_{[t_y, T]}\right) \geq \Delta h(y, y_0). \quad (3.13)$$

We will now focus on proving a lower bound for the length of $\gamma|_{[t_x, t_y]}$.

We want to construct a path γ' joining $x_1 = V_{\gamma(t_x)}(h(x_0))$ to $y_1 = V_{\gamma(t_y)}(h(x_0))$, that stays below $h(x_0)$ and such that $\gamma|_{[t_x, t_y]}$ is contained in γ' . Let $x_1 := V_{\gamma(t_x)}(h(x_0))$ and $y_1 := V_{\gamma(t_y)}(h(x_0))$. We construct γ' by gluing paths together:

$$\gamma' = \begin{cases} V_{\gamma(t_x)} & \text{from } x_1 \text{ to } \gamma(t_x) \\ \gamma & \text{from } \gamma(t_x) \text{ to } \gamma(t_y) \\ V_{\gamma(t_y)} & \text{from } \gamma(t_y) \text{ to } y_1 \end{cases}$$

Applying inequalities (3.9) and (3.10) used on $\gamma(t_x)$ and $\gamma(t_y)$ we get:

$$d(x_0, x_1) \leq 288\delta, \quad (3.14)$$

$$d(y_0, y_1) \leq 288\delta. \quad (3.15)$$

In order to apply Proposition 3.2.1 to γ' we need to check that there exists a point A of the geodesic segment $[x_1, y_1]$ such that $h(A) \geq h(x_0)$. Applying Lemma 3.1.2 to $[x_1, y_1]$ and since $h(x_1) = h(y_1)$ we get:

$$h^+([x_1, y_1]) \geq \frac{d_r(x_1, y_1)}{2} + h(x_0) - 96\delta = \frac{d(x_1, y_1)}{2} + h(x_0) - 96\delta.$$

Thanks to the triangle inequality and inequalities (3.14) and (3.15):

$$h^+([x_1, y_1]) \geq \frac{d(y_0, x_0) - d(x_0, x_1) - d(y_0, y_1)}{2} + h(x_0) - 96\delta \geq \frac{d(x_0, y_0)}{2} + h(x_0) - 384\delta.$$

Since by hypothesis $d(x_0, y_0) > 768\delta$, there exists a point A of $[x_1, y_1]$ exactly at the height:

$$h(A) = \frac{d(x_0, y_0)}{2} + h(x_0) - 384\delta.$$

We can then apply Proposition 3.2.1 to get:

$$\begin{aligned} \delta |\log_2(l(\gamma'))| + 1 &\geq d(A, \gamma') \geq \Delta h(A, x_0) \geq \frac{d(x_0, y_0)}{2} + h(x_0) - 384\delta - h(x_0) \\ &\geq \frac{d(x_0, y_0)}{2} - 384\delta. \end{aligned}$$

Since $\delta \geq 1$, last inequality implies that $l(\gamma') \geq 2^{-385} 2^{\frac{1}{2\delta} d(x_0, y_0)}$. Now we use this inequality to have a lower bound on the length of $\gamma|_{[t_x, t_y]}$:

$$\begin{aligned} l(\gamma|_{[t_x, t_y]}) &\geq l(\gamma') - \Delta h(\gamma(t_x), x_0) - \Delta h(\gamma(t_y), y_0) \\ &\geq 2^{-385} 2^{\frac{1}{2\delta} d(x_0, y_0)} - \Delta h(\gamma(t_x), x_0) - \Delta h(\gamma(t_y), y_0). \end{aligned} \quad (3.16)$$

We claim that $l(\gamma|_{[t_x, t_y]}) \geq \Delta h(\gamma(t_x), x_0) + \Delta h(\gamma(t_y), y_0) - 48\delta$, hence:

$$l(\gamma|_{[t_x, t_y]}) \geq 2^{-386} 2^{\frac{1}{2\delta} d(x_0, y_0)} - 24\delta, \quad (3.17)$$

which ends the proof by combining inequality (3.17) with inequalities (3.12) and (3.13).

Proof of the claim. Inequality (3.11) with $m = \gamma(t_x)$ and $n = \gamma(t_y)$ gives $d(x_1, y_1) \geq 192\delta$. We want to prove that $h^+([\gamma(t_x), \gamma(t_y)]) \geq h(x_1) - 24\delta$. First, by Lemma 2.2.8 we have that $[\gamma(t_x), \gamma(t_y)] \cup V_{\gamma(t_x)} \cup V_{\gamma(t_y)}$ is a 24δ -slim triangle. Then there exist three times t_0, t_1 and t_2 such that $d(V_{\gamma(t_x)}(t_1), \gamma(t_0)) \leq 24\delta$ and such that $d(V_{\gamma(t_y)}(t_2), \gamma(t_0)) \leq 24\delta$. Then:

$$\begin{aligned} |t_1 - t_2| &= \Delta h(V_{\gamma(t_x)}(t_1), V_{\gamma(t_y)}(t_2)) \leq d(V_{\gamma(t_x)}(t_1), V_{\gamma(t_y)}(t_2)) \\ &\leq d(V_{\gamma(t_x)}(t_1), \gamma(t_0)) + d(\gamma(t_0), V_{\gamma(t_y)}(t_2)) \leq 48\delta. \end{aligned} \quad (3.18)$$

We will show by contradiction that either $t_1 = h(V_{\gamma(t_x)}(t_1)) \geq h(x_0)$ or $t_2 = h(V_{\gamma(t_y)}(t_2)) \geq h(x_0)$. Assume that $t_1 < h(x_0)$ and $t_2 < h(x_0)$. Then by the triangle inequality:

$$\begin{aligned} d(V_{\gamma(t_x)}(t_1), V_{\gamma(t_y)}(t_2)) &\geq d(V_{\gamma(t_y)}(t_2), V_{\gamma(t_x)}(t_2)) - d(V_{\gamma(t_x)}(t_2), V_{\gamma(t_x)}(t_1)) \\ &\geq d(V_{\gamma(t_y)}(t_2), V_{\gamma(t_x)}(t_2)) - 48\delta, \text{ since } |t_1 - t_2| \leq 48\delta \text{ by equation (3.18)}. \end{aligned}$$

As H is a Busemann space, the function $t \mapsto d(V_{\gamma(t_x)}(t), V_{\gamma(t_y)}(t))$ is non increasing (convex and bounded function). Furthermore, $h(x_0) \geq t_2$ hence:

$$\begin{aligned} 48\delta &\geq d(V_{\gamma(t_x)}(t_1), V_{\gamma(t_x)}(t_2)) \geq d(V_{\gamma(t_x)}(t_2), V_{\gamma(t_y)}(t_2)) - 48\delta \\ &\geq d(V_{\gamma(t_x)}(h(x_0)), V_{\gamma(t_y)}(h(x_0))) - 48\delta \geq d(x_1, y_1) - 48\delta \\ &\geq d(x_0, y_0) - d(x_0, x_1) - d(y_0, y_1) - 48\delta \geq d(x_0, y_0) - 624\delta, \text{ by inequalities (3.14) and (3.15),} \\ &\geq 49\delta, \text{ since } d(x_0, y_0) \geq 768\delta \text{ by assumption,} \end{aligned}$$

which is impossible. Therefore $t_1 \geq h(x_0)$ or $t_2 \geq h(x_0)$. We assume without loss of generality that $t_1 \geq h(x_0)$, then:

$$\Delta h(\gamma(t_0), V_{\gamma(t_x)}(t_1)) \leq d(\gamma(t_0), V_{\gamma(t_x)}(t_1)) \leq 24\delta,$$

which implies:

$$h^+([\gamma(t_x), \gamma(t_y)]) \geq h(\gamma(t_0)) \geq h(V_{\gamma(t_x)}(t_1)) - \Delta h(\gamma(t_0), V_{\gamma(t_x)}(t_1)) \geq h(x_0) - 24\delta,$$

and gives us:

$$\begin{aligned} l(\gamma|_{[t_x, t_y]}) &\geq h^+([\gamma(t_x), \gamma(t_y)]) - h(\gamma(t_x)) + h^+([\gamma(t_x), \gamma(t_y)]) - h(\gamma(t_y)) \\ &\geq h(x_0) - 24\delta - h(\gamma(t_x)) + h(x_0) - 24\delta - h(\gamma(t_y)) \\ &\geq \Delta h(\gamma(t_x), x_0) + \Delta h(\gamma(t_y), y_0) - 48\delta. \end{aligned} \tag{3.19}$$

□

Next lemma shows that we are able to control the relative distance of a couple of points travelling along two vertical geodesics. We recall that for all $a, b \in H$, $d_r(a, b) = d(a, b) - \Delta h(a, b)$.

Lemma 3.2.3 (Backwards control). *Let $\delta \geq 0$ and H be a proper, δ -hyperbolic, Busemann space. Let V_1 and V_2 be two vertical geodesics of H . Then for all couple of times (t_1, t_2) and for all $t \in [0, \frac{1}{2}d_r(V_1(t_1), V_2(t_2))]$:*

$$\left| d_r \left(V_1 \left(t_1 + \frac{1}{2}d_r(V_1(t_1), V_2(t_2)) - t \right), V_2 \left(t_2 + \frac{1}{2}d_r(V_1(t_1), V_2(t_2)) - t \right) \right) - 2t \right| \leq 288\delta.$$

Proof. To simplify the computations, we use the following notations, $D := t_2 + \frac{1}{2}d_r(V_1(t_1), V_2(t_2))$ and $\Delta = |t_1 - t_2|$. The term Δ is the difference of height between $V_1(t_1)$ and $V_2(t_2)$ since vertical geodesics are parametrised by their height. Then we have to prove that $\forall t \in [0, \frac{1}{2}d_r(V_1(t_1), V_2(t_2))]$, $|d_r(V_1(D - \Delta - t), V_2(D - t)) - 2t| \leq 288\delta$. We can assume without loss of generality that $t_1 \leq t_2$. Lemma 3.1.2 applied with $x = V_1(t_1)$ and with $y = V_2(t_2)$ gives us $d(V_1(D), V_2(D)) \leq 288\delta$. Furthermore, the relative distance is smaller than the distance, hence $d_r(V_1(D), V_2(D)) \leq 288\delta$. Now, if we move the two points backward from $V_1(D - \Delta)$ and $V_2(D)$ along V_1 and V_2 , we have for $t \in [0, D]$:

$$\begin{aligned} d_r(V_1(D - \Delta - t), V_2(D - t)) &= d(V_1(D - \Delta - t), V_2(D - t)) - \Delta \\ &\leq d(V_1(D - \Delta - t), V_1(D - \Delta)) + d(V_1(D - \Delta), V_2(D)) \\ &\quad + d(V_2(D), V_2(D - t)) - \Delta, \end{aligned} \tag{3.20}$$

furthermore V_1 and V_2 are geodesics, then:

$$\begin{aligned} &\leq t + d(V_1(D - \Delta), V_1(D)) + d(V_1(D), V_2(D)) + t - \Delta \\ &\leq t + \Delta + 288\delta + t - \Delta \leq 2t + 288\delta. \end{aligned} \tag{3.21}$$

Let us consider a geodesic α between $V_1(t_1)$ and $V_2(t_2)$. Since H is a Busemann space, and thanks to Lemma 3.1.2 we have $d(V_1(D - \Delta - t), \alpha(D - \Delta - t_1 - t)) \leq 144\delta$ and $d(V_2(D - t), \alpha(D - t_1 + t)) \leq$

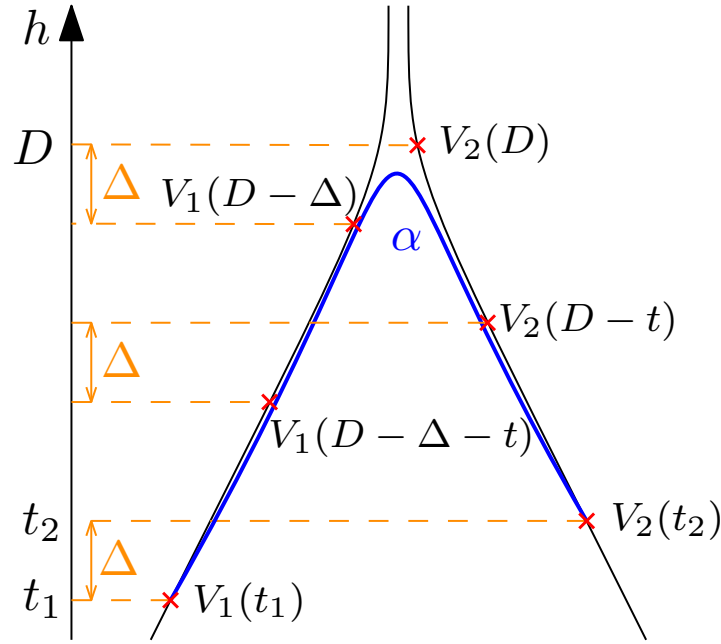

Figure 3.3: Proof of Lemma 3.2.3

144 δ . Then the second part of our inequality follows:

$$\begin{aligned}
 d_r(V_1(D - \Delta - t), V_2(D - t)) &= d(V_1(D - \Delta - t), V_2(D - t)) - \Delta \\
 &\geq d(\alpha(D - \Delta - t_1 - t), \alpha(D - t_1 + t)) \\
 &\quad - d(V_1(D - \Delta - t), \alpha(D - \Delta - t_1 - t)) \\
 &\quad - d(V_2(D - t), \alpha(D - t_1 + t)) - \Delta \\
 &\geq d(\alpha(D - \Delta - t_1 - t), \alpha(D - t_1 + t)) - 288\delta - \Delta \\
 &\geq 2t + \Delta - 288\delta - \Delta \geq 2t - 288\delta.
 \end{aligned} \tag{3.22}$$

□

The next lemma is a slight generalisation of Lemma 3.2.2. The difference being that we control the length of a path with its maximal height instead of the distance between the projection of its extremities on a horosphere.

Lemma 3.2.4. *Let $\delta \geq 1$ and H be a proper, δ -hyperbolic, Busemann space. Let $x, y \in H$ such that $h(x) \leq h(y)$. Let α be a path connecting x to y with $h^+(\alpha) \leq h(y) + \frac{1}{2}d_r(x, y) - \Delta H$ and where ΔH is a positive number such that $\Delta H > 555\delta$. Then:*

$$l(\alpha) \geq d(x, y) + 2^{-530}2^{\frac{1}{\delta}\Delta H} - 2\Delta H - 24\delta.$$

Proof. This proof is illustrated in Figure 3.4. Since $h^+(\alpha) \geq h(y)$ we have that $\frac{1}{2}d_r(x, y) \geq \Delta H$. Applying Lemma 3.2.3 with $V_1 = V_x$, $V_2 = V_y$, $t_1 = h(x)$, $t_2 = h(y)$ and $t = \Delta H$ we have:

$$\left| d_r\left(V_x\left(h(x) + \frac{1}{2}d_r(x, y) - \Delta H\right), V_y\left(h(y) + \frac{1}{2}d_r(x, y) - \Delta H\right)\right) - 2\Delta H \right| \leq 288\delta.$$

Then we have:

$$d_r\left(V_x\left(h(x) + \frac{1}{2}d_r(x, y) - \Delta H\right), V_y\left(h(y) + \frac{1}{2}d_r(x, y) - \Delta H\right)\right) \geq 2\Delta H - 288\delta.$$

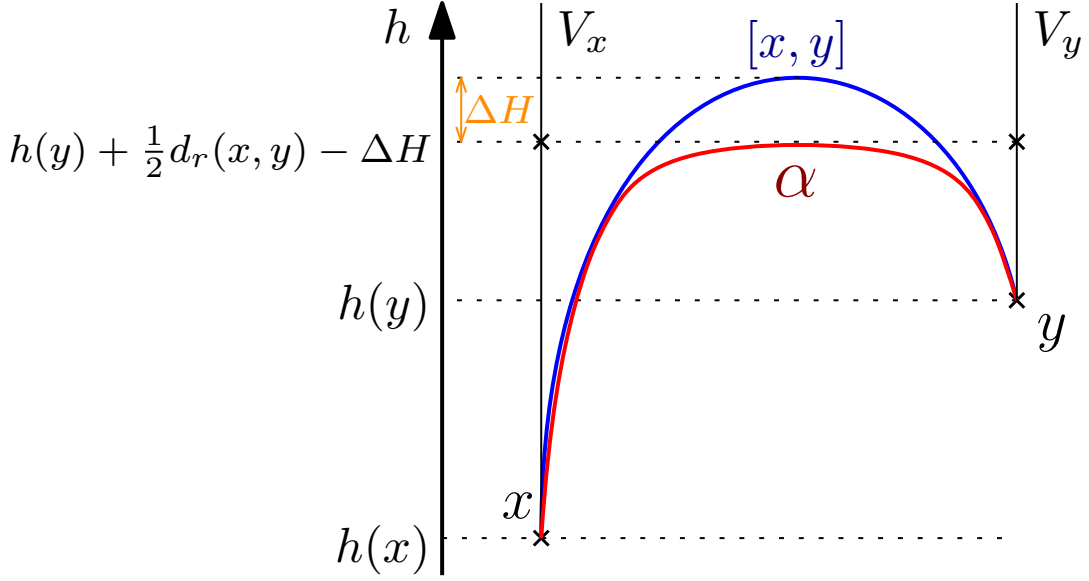

Figure 3.4: Proof of Lemma 3.2.4

Furthermore, Lemma 3.1.3 applied on $V_x\left(h(x) + \frac{1}{2}d_r(x, y) - \Delta H\right)$ and $V_y\left(h(y) + \frac{1}{2}d_r(x, y) - \Delta H\right)$ gives (notice that the only difference between the two sides of the following inequality is the height in the vertical geodesic V_x):

$$\begin{aligned} & d_r\left(V_x\left(h(x) + \frac{1}{2}d_r(x, y) - \Delta H\right), V_y\left(h(y) + \frac{1}{2}d_r(x, y) - \Delta H\right)\right) \\ & \leq d\left(V_x\left(h(y) + \frac{1}{2}d_r(x, y) - \Delta H\right), V_y\left(h(y) + \frac{1}{2}d_r(x, y) - \Delta H\right)\right) + 54\delta. \end{aligned}$$

Then:

$$d\left(V_x\left(h(y) + \frac{1}{2}d_r(x, y) - \Delta H\right), V_y\left(h(y) + \frac{1}{2}d_r(x, y) - \Delta H\right)\right) \geq 2\Delta H - 342\delta > 768\delta. \quad (3.23)$$

Let us denote $t_0 = h(y) + \frac{1}{2}d_r(x, y) - \Delta H$. Thanks to inequality (3.23) the hypothesis of Lemma 3.2.2 holds with $x_0 = V_x\left(h(y) + \frac{1}{2}d_r(x, y) - \Delta H\right)$ and $y_0 = V_y\left(h(y) + \frac{1}{2}d_r(x, y) - \Delta H\right)$. Applying this lemma on α provides:

$$\begin{aligned} l(\alpha) & \geq \Delta h(x, x_0) + \Delta h(y, y_0) + 2^{-386}2^{\frac{1}{2\delta}d(x_0, y_0)} - 24\delta \\ & \geq h(y) + \frac{1}{2}d_r(x, y) - \Delta H - h(x) + h(y) + \frac{1}{2}d_r(x, y) - \Delta H - h(y) + 2^{-386}2^{\frac{1}{2\delta}d(x_0, y_0)} - 24\delta \\ & \geq \Delta h(y, x) + d_r(y, x) - 2\Delta H + 2^{-386}2^{\frac{1}{2\delta}d(x_0, y_0)} - 24\delta \\ & \geq d(x, y) - 2\Delta H + 2^{-386}2^{\frac{1}{2\delta}(2\Delta H - 288\delta)} - 24\delta, \text{ by equation (3.23).} \\ & \geq d(x, y) + 2^{-530}2^{\frac{1}{\delta}\Delta H} - 2\Delta H - 24\delta. \end{aligned}$$

□

This previous lemma tells us that a path needs to reach a sufficient height for its length not to increase to much. We give now a generalisation of Lemma 3.2.4, where the path reaches a given low height before going to its end point. This proposition will be the central result for the understanding of the geodesic shapes in a horospherical product.

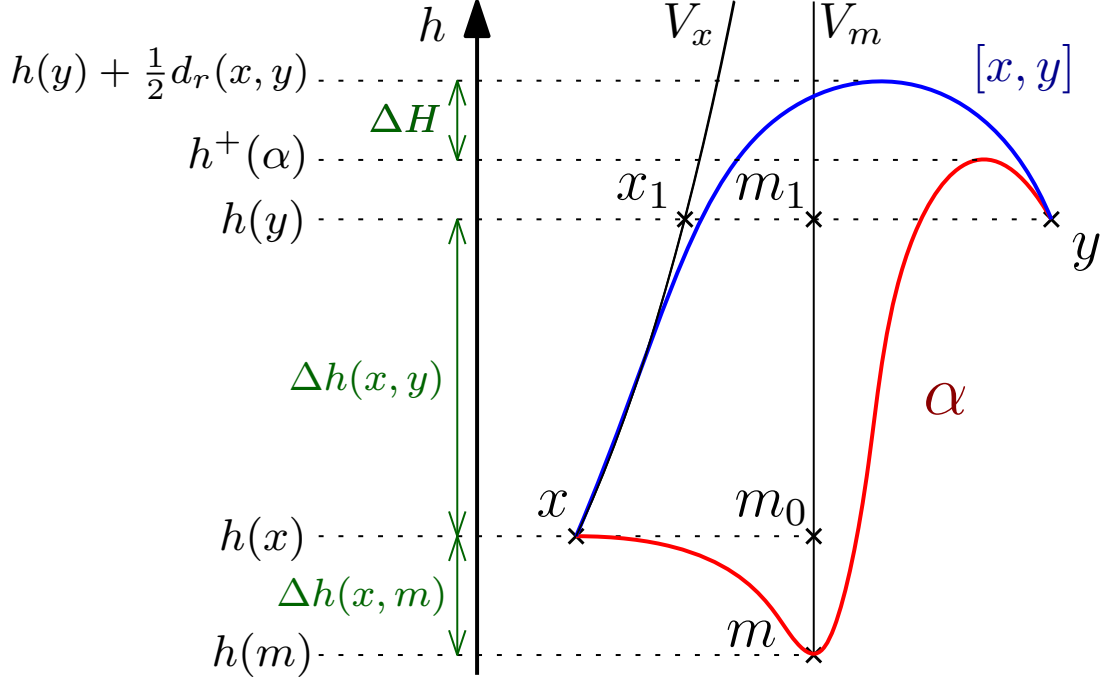

Figure 3.5: Proof of Proposition 3.2.5

Proposition 3.2.5. *Let $\delta \geq 1$ and H be a proper, δ -hyperbolic, Busemann space. Let $x, y, m \in H$ such that $h(m) \leq h(x) \leq h(y)$ and let $\alpha : [0, T] \rightarrow H$ be a path connecting x to y such that $h^-(\alpha) = h(m)$. With the notation $\Delta H = h(y) + \frac{1}{2}d_r(x, y) - h^+(\alpha)$ we have:*

$$l(\alpha) \geq 2\Delta h(x, m) + d(x, y) + 2^{-850}2^{\frac{1}{\delta}\Delta H} - 1 - \max(0, 2\Delta H) - 1700\delta.$$

Proof. This proof is illustrated in Figure 3.5. We first assume that $\Delta H > 850\delta$, we postpone the other cases to the end of this proof. Let V_x and V_m be vertical geodesics respectively containing x and m . We call $x_1 = V_x(h(y))$ and $m_1 = V_m(h(y))$ the points of V_x and V_m at height $h(y)$. First, Lemma 3.1.3 provides $|d(x_1, y) - d_r(x, y)| \leq 54\delta$. Then we consider a geodesic triangle between the three points x_1, m_1 and y . Lemma 3.1.2 tells us that $h^+([x_1, y]) \geq h(y) + \frac{1}{2}d_r(x_1, y) - 96\delta \geq h(y) + \frac{1}{2}d_r(x, y) - 123\delta$. Since $[x_1, y]$ is included in the δ -neighbourhood of the two other sides of the geodesic triangle, one of the two following inequalities holds:

- 1) $h^+([x_1, m_1]) \geq h(y) + \frac{1}{2}d_r(x, y) - 124\delta$
- 2) $h^+([m_1, y]) \geq h(y) + \frac{1}{2}d_r(x, y) - 124\delta$.

We first assume 1) that $h^+([x_1, m_1]) \geq h(y) + \frac{1}{2}d_r(x, y) - 124\delta$, hence:

$$d(x_1, m_1) \geq d_r(x, y) - 248\delta. \quad (3.24)$$

Let us denote $m_0 = V_m(h(x))$ the point of V_m at height $h(x)$. By considering the 2δ -slim quadrilateral between the points x, x_1, m_0, m_1 we have that $[x_1, m_1]$ is in the 2δ -neighbourhood of $[x_1, x] \cup [x, m_0] \cup [m_0, m]$. Furthermore $d_r(x, y) \geq 2(h^+(\alpha) - h(y)) + 2\Delta H \geq 2\Delta H \geq 1700\delta$ by assumption, then $h^+([x_1, m_1]) \geq h(y) + \frac{1}{2}d_r(x, y) - 124\delta \geq h(y) + 726\delta$. Since $h^+([x_1, x]) = h^+([m_0, m_1]) = h(y)$ we have that $h^+([x, m_0]) \geq h^+([x_1, m_1]) - 2\delta \geq h(y) + 724\delta$. Moreover:

$$d_r(x, m_0) = d(x, m_0) \geq h^+([x, m_0]) - h(x) \geq h(y) - h(x) + 724\delta \geq \Delta h(x, y) + 724\delta,$$

which allows us to use Lemma 3.2.3 on V_x and V_m with $t = \frac{1}{2}d_r(x, m_0) - \Delta h(x, y) \geq 0$ and $t_1 = t_2 = h(x)$. It gives:

$$\left| d_r\left(V_x(h(x) + \Delta h(x, y)), V_m(h(x) + \Delta h(x, y))\right) - d_r(x, m_0) + 2\Delta h(x, y) \right| \leq 288\delta,$$

which implies in particular:

$$d_r\left(V_x(h(y)), V_m(h(y))\right) + 2\Delta h(x, y) - 288\delta \leq d_r(x, m_0). \quad (3.25)$$

Combining inequalities 3.24 and 3.25 we have $d(x, m_0) = d_r(x, m_0) \geq d_r(x, y) + 2\Delta h(x, y) - 536\delta$. Lemma 3.1.3 used on x and m then gives:

$$d_r(x, m) \geq d(x, m_0) - 54\delta \geq d_r(x, y) + 2\Delta h(x, y) - 590\delta. \quad (3.26)$$

Let us denote α_1 the part of α linking x to m and α_2 the part of α linking m to y . We have:

$$\begin{aligned} h^+(\alpha_1) &\leq h^+(\alpha) \leq h(y) + \frac{1}{2}d_r(x, y) - \Delta H \leq h(x) + \Delta h(x, y) + \frac{1}{2}d_r(x, y) - \Delta H \\ &\leq h(x) + \frac{1}{2}(2\Delta h(x, y) + d_r(x, y)) - \Delta H \leq h(x) + \frac{1}{2}(d_r(x, m) + 590\delta) - \Delta H, \text{ by inequality 3.26).} \\ &\leq h(x) + \frac{1}{2}d_r(x, m) + 295\delta - \Delta H \leq h(x) + \frac{1}{2}d_r(x, m) - \Delta H', \end{aligned}$$

with $\Delta H' = \Delta H - 295\delta$. By assumption $\Delta H > 850\delta$, hence $\Delta H' > 555\delta$ which allows us to apply Lemma 3.2.4 on α_1 . It follows:

$$\begin{aligned} l(\alpha_1) &\geq d(x, m) + 2^{-530}2^{\frac{1}{5}\Delta H'} - 2\Delta H' - 24\delta \\ &\geq \Delta h(x, m) + d_r(x, m) + 2^{-825}2^{\frac{1}{5}\Delta H} - 2\Delta H - 614\delta, \text{ since } \Delta H' = \Delta H - 295\delta. \\ &\geq \Delta h(x, m) + d_r(x, y) - 590\delta + 2^{-825}2^{\frac{1}{5}\Delta H} - 2\Delta H - 614\delta, \text{ by inequality 3.26} \\ &\geq \Delta h(x, m) + d_r(x, y) + 2^{-825}2^{\frac{1}{5}\Delta H} - 2\Delta H - 1204\delta. \end{aligned}$$

We use in the following inequalities that $l(\alpha_2) \geq d(m, y) \geq \Delta h(m, y)$, we have:

$$\begin{aligned} l(\alpha) &\geq l(\alpha_1) + l(\alpha_2) \geq \Delta h(x, m) + d_r(x, y) + 2^{-825}2^{\frac{1}{5}\Delta H} - 2\Delta H - 1204\delta + \Delta h(m, y) \\ &\geq 2\Delta h(x, m) + \Delta h(x, y) + d_r(x, y) + 2^{-825}2^{\frac{1}{5}\Delta H} - 2\Delta H - 1204\delta \\ &\geq 2\Delta h(x, m) + d(x, y) + 2^{-825}2^{\frac{1}{5}\Delta H} - 2\Delta H - 1204\delta \\ &\geq 2\Delta h(x, m) + d(x, y) + 2^{-850}2^{\frac{1}{5}\Delta H} - 1 - 2\Delta H - 1700\delta, \\ &\geq 2\Delta h(x, m) + d(x, y) + 2^{-850}2^{\frac{1}{5}\Delta H} - 1 - \max(0, 2\Delta H) - 1700\delta, \text{ since } \Delta H > 850\delta \geq 0, \end{aligned}$$

which ends the proof for case 1).

Now assume that 2) holds, which is $h^+([m_1, y]) \geq h(y) + \frac{1}{2}d_r(x, y) - 124\delta$. It implies $d(m_1, y) \geq d_r(x, y) - 248\delta$, then:

$$\begin{aligned} h^+(\alpha_2) &\leq h^+(\alpha) \leq h(y) + \frac{1}{2}d_r(x, y) - \Delta H \leq h(y) + \frac{1}{2}d_r(m_1, y) + 124\delta - \Delta H \\ &\leq h(y) + \frac{1}{2}d_r(m_1, y) - \Delta H'', \end{aligned}$$

with $\Delta H'' = \Delta H - 124\delta$. Lemma 3.1.3 provides us with:

$$d_r(m, y) \geq d(m_1, y) - 54\delta \geq d_r(x, y) - 302\delta. \quad (3.27)$$

Since $\Delta H > 850\delta$, we have $\Delta H'' > 726\delta$ which allows us to apply Lemma 3.2.4 on α_2 . It follows that:

$$\begin{aligned} l(\alpha_2) &\geq d(y, m) + 2^{-530}2^{\frac{1}{8}\Delta H''} - 2\Delta H'' - 24\delta \\ &\geq \Delta h(y, m) + d_r(y, m) + 2^{-654}2^{\frac{1}{8}\Delta H} - 2\Delta H - 272\delta, \text{ since } \Delta H'' = \Delta H - 124\delta. \\ &\geq \Delta h(y, m) + d_r(x, y) + 2^{-654}2^{\frac{1}{8}\Delta H} - 2\Delta H - 574\delta, \text{ by inequality (3.25)}. \end{aligned}$$

Hence:

$$\begin{aligned} l(\alpha) &\geq l(\alpha_1) + l(\alpha_2) \geq \Delta h(x, m) + \Delta h(y, m) + d_r(x, y) + 2^{-654}2^{\frac{1}{8}\Delta H} - 2\Delta H - 574\delta \\ &\geq 2\Delta h(x, m) + \Delta h(y, x) + d_r(x, y) + 2^{-654}2^{\frac{1}{8}\Delta H} - 2\Delta H - 574\delta \\ &\geq 2\Delta h(x, m) + d(x, y) + 2^{-654}2^{\frac{1}{8}\Delta H} - 2\Delta H - 574\delta \\ &\geq 2\Delta h(x, m) + d(x, y) + 2^{-850}2^{\frac{1}{8}\Delta H} - 1 - \max(0, 2\Delta H) - 1700\delta. \end{aligned}$$

There remains to treat the case when $\Delta H \leq 850\delta$, where $\Delta H = h(y) + \frac{1}{2}d_r(x, y) - h^+(\alpha)$. Let n denote a point of α such that $h(n) = h^+(\alpha)$. If m comes before n , we have $l(\alpha) \geq d(x, m) + d(m, n) + d(n, y)$. Otherwise n comes before m and we have $l(\alpha) \geq d(x, n) + d(n, m) + d(m, y)$. Since $h(m) \leq h(x) \leq h(y) \leq h(n)$ we always have:

$$\begin{aligned} l(\alpha) &\geq \Delta h(x, m) + \Delta h(m, n) + \Delta h(n, y) \\ &\geq \Delta h(x, m) + \Delta h(m, x) + \Delta h(x, y) + \Delta h(y, n) + \Delta h(y, n) \\ &\geq 2\Delta h(x, m) + \Delta h(x, y) + 2(h^+(\alpha) - h(y)) \\ &\geq 2\Delta h(x, m) + \Delta h(x, y) + d_r(x, y) - 2\Delta H \geq 2\Delta h(m, x) + d(x, y) - 1700\delta. \end{aligned}$$

Furthermore $\Delta H \leq 850\delta$, then $2^{-850}2^{\frac{1}{8}\Delta H} \leq 1$. Therefore:

$$l(\alpha) \geq 2\Delta h(m, x) + d(x, y) + 2^{-850}2^{\frac{1}{8}\Delta H} - 1 - \max(0, 2\Delta H) - 1700\delta,$$

which ends the proof for the remaining case. □

Chapter 4

Horospherical products

4.1 Definitions

In this part we generalise the definition of horospherical product, as seen in [10, Eskin, Fisher, Whyte] for two trees or two hyperbolic planes, to any pair of proper, geodesically complete, Gromov hyperbolic, Busemann spaces. We recall that given a proper, δ -hyperbolic space H with distinguished $a \in \partial H$ and $w \in H$, we defined the height function on H in Definition 2.2.1 from the Busemann functions with respect to a and w .

Definition 4.1.1 (Horospherical product). *Let X and Y be two δ -hyperbolic spaces. We fix the base points $w_X \in X$, $w_Y \in Y$ and the directions in the boundaries $a_X \in \partial X$, $a_Y \in \partial Y$. We consider their height functions X and Y respectively on X and Y . We define the horospherical product of X and Y , denoted $X \bowtie Y = X \bowtie Y$, by:*

$$X \bowtie Y := \{(p_X, p_Y) \in X \times Y \mid h_X(p_X) + h_Y(p_Y) = 0\}.$$

From now on, with slight abuse, we omit the base points and fixed points on the boundary in the construction of the horospherical product. The metric space $X \bowtie Y$ refers to a horospherical product of two Gromov hyperbolic Busemann spaces. We choose to denote X and Y the two components in order to identify easily which objects are in which component.

One of our goals is to understand the shape of geodesics in $X \bowtie Y$ according to a given distance on it. In a cartesian product the chosen distance changes the behaviour of geodesics. However we show that in a horospherical product the shape of geodesics does not change for a large family of distances, up to an additive constant.

We will define the distances on $X \bowtie Y = X \bowtie Y$ as length path metrics induced by distances on $X \times Y$. A lot of natural distances on the cartesian product $X \times Y$ come from norms on the vector space \mathbb{R}^2 . Let N be such a norm and let us denote $d_N := N(d_X, d_Y)$, which means that for all couples $(p_X, p_Y), (q_X, q_Y) \in X \times Y$ we have that $d_N((p_X, p_Y), (q_X, q_Y)) = N(d_X(p_X, q_X), d_Y(p_Y, q_Y))$. The length $l_N(\gamma)$ of a path $\gamma = (\gamma_X, \gamma_Y)$ in the metric space $(X \times Y, d_N)$ is defined by:

$$l_N(\gamma) = \sup_{\theta \in \Theta([t_1, t_2])} \left(\sum_{i=1}^{n_\theta-1} d_N(\gamma(\theta_i), \gamma(\theta_{i+1})) \right).$$

Where $\Theta([t_1, t_2])$ is the set of subdivisions of $[t_1, t_2]$. Then the N -path metrics on $X \bowtie Y$ is:

Definition 4.1.2 (The N -path metrics on $X \bowtie Y$). *Let N be a norm on the vector space \mathbb{R}^2 . The N -path metric on $X \bowtie Y$, denoted by d_\bowtie , is the length path metric induced by the distance $N(d_X, d_Y)$ on $X \times Y$. For all p and q in $X \bowtie Y$ we have:*

$$d_\bowtie(p, q) = \inf\{l_N(\gamma) \mid \gamma \text{ path in } X \bowtie Y \text{ linking } p \text{ to } q\}. \quad (4.1)$$

Any norm N on \mathbb{R}^2 can be normalised such that $N(1, 1) = 1$. We call admissible any such norm which satisfies an additional condition.

Definition 4.1.3 (Admissible norm). *Let N be a norm on the vector space \mathbb{R}^2 such that $N(1, 1) = 1$. The norm N is called admissible if and only if for all real a and b we have:*

$$N(a, b) \geq \frac{a+b}{2}. \quad (4.2)$$

Since all norms are equivalent in \mathbb{R}^2 , there exists a constant $C_N \geq 1$ such that:

$$N(a, b) \leq C_N \frac{a+b}{2}. \quad (4.3)$$

As an example, any l_p norm with $p \geq 1$ is admissible.

Property 4.1.4. *Let N be an admissible norm on the vector space \mathbb{R}^2 . Let $\gamma := (\gamma_X, \gamma_Y) \subset X \times Y$ be a connected path. Then we have:*

$$\frac{l_X(\gamma_X) + l_Y(\gamma_Y)}{2} \leq l_N(\gamma) \leq C_N \frac{l_X(\gamma_X) + l_Y(\gamma_Y)}{2}.$$

Proof. Let $\gamma := (\gamma_X, \gamma_Y) : [t_1, t_2] \rightarrow X \times Y$ be a connected path and θ a subdivision of $[t_1, t_2]$, then by the definition of the length:

$$\begin{aligned} l_N(\gamma) &\geq \sum_{i=1}^{n_\theta-1} d_N(\gamma(\theta_i), \gamma(\theta_{i+1})) = \sum_{i=1}^{n_\theta-1} N\left(d_X(\gamma_X(\theta_i), \gamma_X(\theta_{i+1})), d_Y(\gamma_Y(\theta_i), \gamma_Y(\theta_{i+1}))\right) \\ &\geq \sum_{i=1}^{n_\theta-1} \frac{1}{2} \left(d_X(\gamma_X(\theta_i), \gamma_X(\theta_{i+1})) + d_Y(\gamma_Y(\theta_i), \gamma_Y(\theta_{i+1})) \right), \text{ since } N \text{ is admissible.} \\ &\geq \frac{1}{2} \left(\sum_{i=1}^{n_\theta-1} d_X(\gamma_X(\theta_i), \gamma_X(\theta_{i+1})) + \sum_{i=1}^{n_\theta-1} d_Y(\gamma_Y(\theta_i), \gamma_Y(\theta_{i+1})) \right). \end{aligned}$$

Any couple of subdivision θ_1 and θ_2 can be merge into a subdivision θ that contains θ_1 and θ_2 . Furthermore the last inequality holds for any subdivision θ , hence by taking the supremum on all the subdivisions we have:

$$l_N(\gamma) \geq \frac{l_X(\gamma_X) + l_Y(\gamma_Y)}{2}.$$

Furthermore, we have that $\forall a, b \in \mathbb{R}$, $N(a, b) \leq C_N \frac{a+b}{2}$, hence:

$$\begin{aligned} \sum_{i=1}^{n_\theta-1} d_N(\gamma(\theta_i), \gamma(\theta_{i+1})) &\leq \frac{C_N}{2} \left(\sum_{i=1}^{n_\theta-1} d_X(\gamma_X(\theta_i), \gamma_X(\theta_{i+1})) + \sum_{i=1}^{n_\theta-1} d_Y(\gamma_Y(\theta_i), \gamma_Y(\theta_{i+1})) \right) \\ &\leq C_N \frac{l_X(\gamma_X) + l_Y(\gamma_Y)}{2} \end{aligned}$$

Since last inequality holds for any subdivision θ , we have that $l_N(\gamma) \leq C_N \frac{l_X(\gamma_X) + l_Y(\gamma_Y)}{2}$. □

The definition of height on X and Y is used to construct a height function on $X \rtimes Y$.

Definition 4.1.5 (Height on $X \rtimes Y$). *The height $h(p)$ of a point $p = (p_X, p_Y) \in X \rtimes Y$ is defined as $h(p) = h_X(p_X) = -h_Y(p_Y)$.*

On Gromov hyperbolic spaces we have that the distance between two points is greater than their height difference. The same occurs on horospherical products given with an admissible norm. Let x and y be two points of $X \rtimes Y$, and let us denote $\Delta h(p, q) := |h(p) - h(q)|$ their height difference.

Lemma 4.1.6. *Let N be an admissible norm, and let d_{\bowtie} the distance on $X \bowtie Y$ induced by N . Then the height function is 1-Lipschitz with respect to the distance d_{\bowtie} , i.e.,*

$$\forall p, q \in X \bowtie Y, \quad d_{\bowtie}(p, q) \geq \Delta h(p, q). \quad (4.4)$$

Proof. Since N is admissible we have:

$$\begin{aligned} d_{\bowtie}(p, q) &\geq \frac{d_X(p_X, q_X) + d_Y(p_Y, q_Y)}{2} \geq \frac{\Delta h(p_X, q_X) + \Delta h(p_Y, q_Y)}{2} \\ &= \Delta h(p_X, q_X) = \Delta h(p, q). \end{aligned}$$

□

Following Proposition [2.3.2](#), we define a notion of vertical paths in a horospherical product.

Definition 4.1.7 (Vertical paths in $X \bowtie Y$). *Let $V : \mathbb{R} \rightarrow X \bowtie Y$ be a connected path. We say that V is vertical if and only if there exists a parametrisation by arclength of V such that $h(V(t)) = t$ for all t .*

Actually, a vertical path of a horospherical product is a geodesic.

Lemma 4.1.8. *Let N be an admissible norm. Let $V : \mathbb{R} \rightarrow X \bowtie Y$ be a vertical path. Then V is a geodesic of $(X \bowtie Y, d_{\bowtie})$.*

Proof. Let $t_1, t_2 \in \mathbb{R}$. The path V is vertical therefore $\Delta h(V(t_1), V(t_2)) = |t_1 - t_2|$. Since V is connected and parametrised by arclength, we have that:

$$\begin{aligned} |t_1 - t_2| &= l_N(V_{|[t_1, t_2]}) \geq d_{\bowtie}(V(t_1), V(t_2)) \\ &\geq \Delta h(V(t_1), V(t_2)) = |t_1 - t_2|. \end{aligned}$$

Then $d_{\bowtie}(V(t_1), V(t_2)) = |t_1 - t_2|$, which ends the proof. □

Such geodesics are called vertical geodesics. Next proposition tells us that vertical geodesics of $X \bowtie Y$ are exactly couples of vertical geodesics of X and Y .

Proposition 4.1.9. *Let N be an admissible norm and let $V = (V_X, V_Y) : \mathbb{R} \rightarrow X \bowtie Y$ be a geodesic of $(X \bowtie Y, d_{\bowtie})$. The two following properties are equivalent:*

1. V is a vertical geodesic of $(X \bowtie Y, d_{\bowtie})$
2. V_X and V_Y are respectively vertical geodesics of X and Y .

Proof. Let us first assume that V be a vertical geodesic, we have for all real t that $h(V_X(t)) = h(V(t)) = t$, hence $\forall t_1, t_2 \in \mathbb{R}$:

$$d_X(V_X(t_1), V_X(t_2)) \geq \Delta h(V_X(t_1), V_X(t_2)) = |t_1 - t_2|. \quad (4.5)$$

Similarly we have that $d_Y(V_Y(t_1), V_Y(t_2)) \geq |t_1 - t_2|$. Using that N is admissible and that V is a geodesic we have:

$$\begin{aligned} d_X(V_X(t_1), V_X(t_2)) &= 2 \frac{d_X(V_X(t_1), V_X(t_2)) + d_Y(V_Y(t_1), V_Y(t_2))}{2} - d_Y(V_Y(t_1), V_Y(t_2)) \\ &\leq 2d_{\bowtie}(V(t_1), V(t_2)) - |t_1 - t_2| = |t_1 - t_2|. \end{aligned}$$

Combine with inequality (4.5) we have that $d_X(V_X(t_1), V_X(t_2)) = |t_1 - t_2|$, hence V_X is a vertical geodesic of X . Similarly, V_Y is a vertical geodesic of Y .

Let us assume that V_X and V_Y are vertical geodesics of X and Y . Let $t_1, t_2 \in \mathbb{R}$, we have:

$$\begin{aligned}
d_{\bowtie}(V(t_1), V(t_2)) &= \sup_{\theta \in \Theta([t_1, t_2])} \left(\sum_{i=1}^{n_\theta-1} d_N(V(\theta_i), V(\theta_{i+1})) \right) \\
&= \sup_{\theta \in \Theta([t_1, t_2])} \left(\sum_{i=1}^{n_\theta-1} N(d_X(V_X(\theta_i), V_X(\theta_{i+1})), d_Y(V_Y(\theta_i), V_Y(\theta_{i+1}))) \right) \\
&= \sup_{\theta \in \Theta([t_1, t_2])} \left(\sum_{i=1}^{n_\theta-1} N(\Delta h(V_X(\theta_i), V_X(\theta_{i+1})), \Delta h(V_Y(\theta_i), V_Y(\theta_{i+1}))) \right) \\
&= \sup_{\theta \in \Theta([t_1, t_2])} \left(N(1, 1) \sum_{i=1}^{n_\theta-1} \Delta h(V_X(\theta_i), V_X(\theta_{i+1})) \right) \\
&= N(1, 1) \Delta h(V_X(t_1), V_X(t_2)) = |t_1 - t_2|, \text{ since } N(1, 1) = 1.
\end{aligned}$$

Where $\Theta([t_1, t_2])$ is the set of subdivision of $[t_1, t_2]$. Hence the proposition is proved. \square

This previous result is the main reason why we are working with distances which came from admissible norms.

Definition 4.1.10. A geodesic ray of $X \bowtie Y$ is called vertical if it is a subset of a vertical geodesic.

A metric space is called geodesically complete if all its geodesic segments can be prolonged into geodesic lines. If X and Y are proper hyperbolic geodesically complete Busemann spaces, their horospherical product $X \bowtie Y$ is connected.

Property 4.1.11. Let X and Y be two proper, geodesically complete, δ -hyperbolic, Busemann spaces. Let $X \bowtie Y$ be their horospherical product. Then $X \bowtie Y$ is connected, furthermore $\frac{1}{2}(d_X + d_Y) \leq d_{X \bowtie Y} \leq 2C_N(d_X + d_Y)$.

Proof. Let $p = (p_X, p_Y)$ and $q = (q_X, q_Y)$ be two points of $X \bowtie Y$. From Property 2.3.3, there exists a vertical geodesic V_{p_Y} such that p_Y is in the image of V_{p_Y} , and there exists a vertical geodesic V_{q_X} such that q_X is in the image of V_{q_X} . Let q'_Y be the point of V_{p_Y} at height $h(q_Y)$. Let α_X be a geodesic of X linking p_X to q_X and let α'_Y be a geodesic of Y linking q'_Y to q_Y . We will connect x to y with a path composed with pieces of α_X , α'_Y , V_{p_Y} and V_{q_X} .

We first link (p_X, p_Y) to (q_X, q'_Y) with α_X and V_{p_Y} . It is possible since V_{p_Y} is parametrised by its height. More precisely we construct the following path c_1 :

$$\forall t \in [0, d(p_X, q_X)], c_1(t) = (\alpha_X(t), V_{p_Y}(-h(\alpha_X(t)))).$$

Since V_{p_Y} is parametrised by its height, we have $h(V_{p_Y}(-h(\alpha_X(t)))) = -h(\alpha_X(t))$ which implies $c_1(t) \in X \bowtie Y$. Furthermore, using the fact that the height is 1-Lipschitz, we have $\forall t_1, t_2 \in [0, d(p_X, q_X)]$:

$$d_Y(V_{p_Y}(-h(\alpha_X(t_1))), V_{p_Y}(-h(\alpha_X(t_2)))) = |h(\alpha_X(t_1)) - h(\alpha_X(t_2))| \leq d_X(\alpha_X(t_1), \alpha_X(t_2)).$$

Hence $c_{1,Y} : t \mapsto V_{p_Y}(-h(\alpha_X(t)))$ is a connected path such that $l(c_{1,Y}) \leq l(\alpha_X) \leq d_X(p_X, q_X)$. Hence c_1 is a connected path linking (p_X, p_Y) to (q_X, q'_Y) . Using Property 4.1.4 on c_1 provides us with:

$$\begin{aligned}
l_N(c_1) &\leq \frac{C_N}{2}(l(c_{1,Y}) + l(\alpha_X)) \leq C_N l(\alpha_X) \\
&\leq C_N d_X(p_X, q_X)
\end{aligned}$$

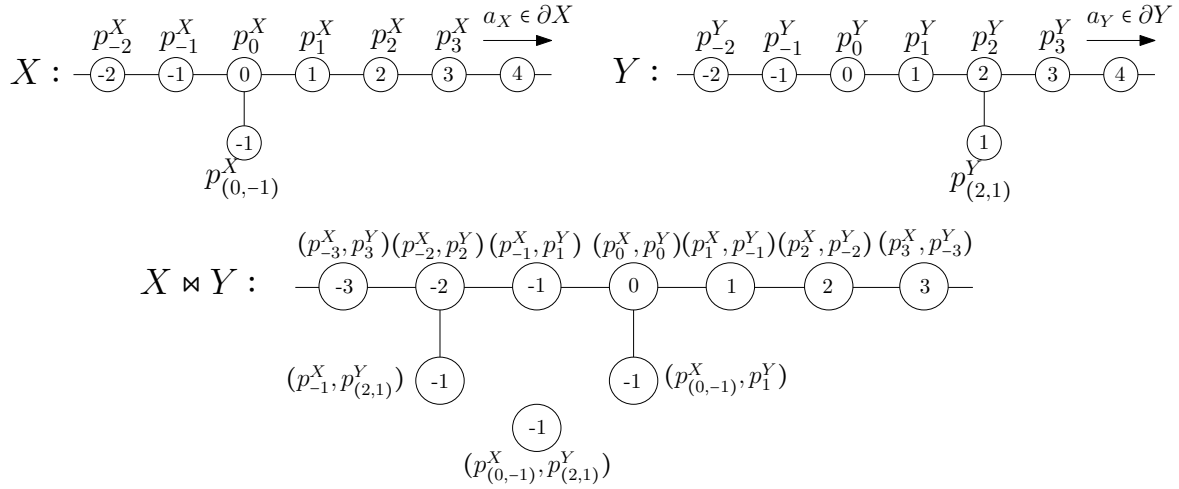

Figure 4.1: Example of horospherical product which is not connected. The number in a vertex is the height of that vertex.

We recall that by definition $q'_Y = V_{p_Y}(h(q_Y))$. We show similarly that $c_2 : t \mapsto (V_{q_X}(-h(\alpha'_Y(t))), \alpha'_Y(t))$ is a connected path linking (q_X, q'_Y) to (q_X, q_Y) such that:

$$\begin{aligned} l(c_2) &\leq C_N d_Y(q'_Y, q_Y) \leq C_N (d_Y(q'_Y, p_Y) + d_Y(p_Y, q_Y)) \\ &= C_N (\Delta h(p_Y, q_Y) + d_Y(p_Y, q_Y)), \text{ since } q'_Y = V_{p_Y}(h(q_Y)) \\ &\leq 2C_N d_Y(p_Y, q_Y). \end{aligned}$$

Hence, there exists a connected path $c = c_1 \cup c_2$ linking p to q such that:

$$l(c) \leq C_N d_X(p_X, q_X) + 2C_N d_Y(p_Y, q_Y) \leq 2C_N (d_X(p_X, q_X) + d_Y(p_Y, q_Y)). \quad (4.6)$$

□

However if the two components X and Y are not geodesically complete, $X \rtimes Y$ may not be connected.

Example 4.1.12. Let X and Y be two graphs, constructed from an infinite line \mathbb{Z} (indexed by \mathbb{Z}) with an additional vertex glued on the 0 for X and on the -2 for Y . Their construction are illustrated in Figure 4.1. They are two 0-hyperbolic Busemann spaces which are not geodesically complete. Let $w_X \in X$ be the vertex indexed by 0 in X , and let $w_Y \in Y$ be the vertex indexed by -2 in Y . We choose them to be the base points of X and Y . Since ∂X and ∂Y contain two points each, we fix in both cases the point of the boundary a_X or a_Y to be the one that contains the geodesic ray indexed by \mathbb{N} . On figure 4.1, we denoted the height of a vertex inside this one. Then the horospherical product $X \rtimes Y$ taken with the ℓ_1 path metric is not connected. Since some vertices of X and Y are not contained in a vertical geodesic, one may not be able to adapt its height correctly while constructing a path joining $(p_{-1}^X, p_{(2,1)}^Y)$ to $(p_{(0,-1)}^X, p_{(2,1)}^Y)$.

It is not clear that a horospherical product is still connected without the hypothesis that X and Y are Busemann spaces. In that case we would need a "coarse" definition of horospherical product. Indeed, the height along geodesics would not be smooth as in Proposition 2.3.2, therefore the condition requiring to have two exact opposite heights would not suits.

4.2 Examples

A first example of horospherical product is the family of Diestel-Leader graphs. They are by construction horospherical products of two trees.

Definition 4.2.1 (Diestel-Leader graph $DL(n, m)$). Let $n \geq 2$ and $m \geq 2$ be two integers. Let T_n be the n -homogeneous tree and T_m be the m -homogeneous tree. The two graphs T_n and T_m are 0-hyperbolic proper geodesically complete Busemann spaces. The Diestel-Leader graph $DL(n, m)$ is defined by $DL(n, m) = T_n \rtimes T_m$.

We see T_n and T_m as connected metric spaces with the usual distance on them. By choosing half of the ℓ_1 path metric on $DL(n, m)$, this horospherical product becomes a graph with the usual distance on it. Indeed, the set of vertices of $DL(n, m)$ is then defined by the subset of couples of vertices of $T_n \times T_m$ included in $DL(n, m)$. In this horospherical product, two points (p_n, p_m) and (q_n, q_m) of $DL(n, m)$ are connected by an edge if and only if p_n and q_n are connected by an edge in T_n and if p_m and q_m are connected by an edge in T_m . Furthermore, when $n = m$, there is a one-to-one correspondance between $DL(n, n)$ and the Cayley graph of the lamplighter group $\mathbb{Z}_Y \wr \mathbb{Z}$, see [27, Woess] for further details.

The Sol geometry is the Riemannian manifold with coordinates $(x, y, z) \in \mathbb{R}^3$ and with the Riemannian metric $ds^2 = dz^2 + e^{2z} dx^2 + e^{-2z} dy^2$. It is the horospherical product of two hyperbolic planes, it is described in [28, Woess]. Let us consider \mathbb{H}^2 the Log model of the hyperbolic plane, defined as the Riemannian manifold with coordinates $(x, z) \in \mathbb{R}^2$ and with the Riemannian metric $ds^2 = dz^2 + e^{-2z} dx^2$. We fix $w = (0, 0)$ as the base point of \mathbb{H} and the "upward" direction a as the point on the boundary. In that case the height function in regards to (a, w) taken on a point $(x, z) \in \mathbb{H}$ is $h_{(a,w)}(x, z) = z$. We now look at the horospherical product $\mathbb{H}^2 \rtimes \mathbb{H}^2 := \{(x_1, z_1, x_2, z_2) \in \mathbb{R}^2 \times \mathbb{R}^2 \mid z_1 = -z_2\}$ taken with the ℓ_2 path metric. Since the second and the fourth variable are exactly opposite, we merge them into one. Hence we have that $\mathbb{H}^2 \rtimes \mathbb{H}^2$ is isometric to the space $\{(x_1, x_2, z_1) \in \mathbb{R}^3\}$ with the metric

$$ds^2 = dz_1^2 + e^{-2z_1} dx_1^2 + dz_1^2 + e^{2z_1} dx_2^2 = 2dz_1^2 + e^{-2z_1} dx_1^2 + e^{2z_1} dx_2^2.$$

Changing the coordinates by dividing x_1 and x_2 by two tells us that this space is isometric to Sol.

Depending on the case, we either used the ℓ_1 path metric or the ℓ_2 path metric. Proposition 4.3.5 tells us that it does not matter, up to an additive uniform constant. Quasi-isometric rigidity results have been proved in the Diestel-Leader graphs and the Sol geometry with the same techniques in [10, Eskin, Fisher, Whyte] and [11, E,F,W].

The horospherical product of a hyperbolic plane and a regular tree has been studied as the 2-complex of Baumslag-Solitar groups in [2, Bendikov, Saloff-Coste, Salvatori, Woess]. They are called the treebolic spaces. The distance they choose on the treebolic spaces is similar to ours. In fact our Proposition 4.3.4 and their Proposition 2.8 page 9 (in [2]) tell us they are equal up to an additive constant. Rigidity results on the treebolic spaces were brought up in [12, Farb, Mosher] and [13, F,M].

The previous examples were already known, however our construction still works for many other spaces. As an example, a geodesically complete manifold with a curvature lower than a negative constant could be used as the component X or Y in the horospherical product.

4.3 Length of geodesic segments in $X \rtimes Y$

From now on, unless otherwise specified, X and Y will always be two proper, geodesically complete, δ -hyperbolic, Busemann spaces with $\delta \geq 1$, and N will always be an admissible norm. Let p and q be two points of $X \rtimes Y$, and let α be a geodesic of $X \rtimes Y$ connecting them. We first prove an upper bound on the length of α by computing the length of a path $\gamma \subset X \rtimes Y$ linking p to q

Lemma 4.3.1. Let $p = (p_X, p_Y)$ and $q = (q_X, q_Y)$ be points of the horospherical product $X \rtimes Y$. There exists a path γ connecting p to q such that:

$$l_N(\gamma) \leq d_r(p_Y, q_Y) + d_r(p_X, q_X) + \Delta h(p, q) + 1152\delta C_N.$$

Proof. Without loss of generality, we assume $h(p) \leq h(q)$. One can follow the idea of the proof on Figure 4.2. We consider V_{p_X} and V_{q_X} two vertical geodesics of X containing p_X and q_X respectively. Similarly let V_{p_Y} and V_{q_Y} be two vertical geodesics of Y containing p_Y and q_Y respectively. We will use them to construct γ . Let A_1 be the point of the vertical geodesic $(V_{p_X}, V_{p_Y}) \subset X \bowtie Y$ at height $h(p) - \frac{1}{2}d_r(p_Y, q_Y)$ and A_2 be the point of the vertical geodesic $(V_{p_X}, V_{q_Y}) \subset X \bowtie Y$ at the same height $h(p) - \frac{1}{2}d_r(p_Y, q_Y)$. Let A_3 be the point of the vertical geodesic (V_{p_X}, V_{q_Y}) at height $h(q) + \frac{1}{2}d_r(p_X, q_X)$ and A_4 be the point of the vertical geodesic (V_{q_X}, V_{q_Y}) at the same height $h(q) + \frac{1}{2}d_r(p_X, q_X)$. Then $\gamma := \gamma_1 \cup \gamma_2 \cup \gamma_3 \cup \gamma_4 \cup \gamma_5$ is constructed as follows:

- γ_1 is the part of (V_{p_X}, V_{p_Y}) linking p to A_1 .
- γ_2 is a geodesic linking A_1 to A_2 . Such a geodesic exists by Property 4.1.11.
- γ_3 is the part of (V_{p_X}, V_{q_Y}) linking A_2 to A_3 .
- γ_4 is a geodesic linking A_3 to A_4 . Such a geodesic exists by Property 4.1.11.
- γ_5 is the part of (V_{q_X}, V_{q_Y}) linking A_4 to q .

In fact A_1 and A_2 are close to each other. Indeed, the two points $A_1 = (A_{1,X}, A_{1,Y})$ and $A_2 = (A_{2,X}, A_{2,Y})$ are characterised by the two geodesics (V_{p_X}, V_{p_Y}) and (V_{p_X}, V_{q_Y}) . Then, because $-h(q) = Y(q_Y) \leq Y(p_Y)$, Lemma 3.1.2 applied on p_Y and q_Y in Y gives us $d_Y(A_{1,Y}, A_{2,Y}) \leq 288\delta$. Furthermore Property 4.1.11 provides us with $d_{\bowtie} \leq 2C_N(d_X + d_Y)$, however we have that $A_{1,X} = A_{2,X}$ hence:

$$d_{\bowtie}(A_1, A_2) \leq 576\delta C_N. \quad (4.7)$$

Lemma 3.1.2 applied on p_X and q_X provides similarly:

$$d_{\bowtie}(A_3, A_4) \leq 576\delta C_N, \quad (4.8)$$

which gives us:

$$\begin{aligned} l_N(\gamma) &= l_N(\gamma_1) + l_N(\gamma_2) + l_N(\gamma_3) + l_N(\gamma_4) + l_N(\gamma_5) \\ &= d_{\bowtie}(p, A_1) + d_{\bowtie}(A_1, A_2) + d_{\bowtie}(A_2, A_3) + d_{\bowtie}(A_3, A_4) + d_{\bowtie}(A_4, q) \\ &\quad \text{Since } \gamma_1, \gamma_3 \text{ and } \gamma_5 \text{ are vertical geodesics, we have:} \\ &= \Delta h(p, A_1) + d_{\bowtie}(A_1, A_2) + \Delta h(A_2, A_3) + d_{\bowtie}(A_3, A_4) + \Delta h(A_4, q) \\ &= \frac{1}{2}d_r(p_Y, q_Y) + d_{\bowtie}(A_1, A_2) + \frac{1}{2}d_r(p_Y, q_Y) + \frac{1}{2}d_r(p_X, q_X) + \Delta h(p, q) \\ &\quad + d_{\bowtie}(A_3, A_4) + \frac{1}{2}d_r(p_X, q_X) \\ &\leq d_r(p_Y, q_Y) + d_r(p_X, q_X) + \Delta h(p, q) + 1152\delta C_N, \text{ by inequalities (4.7) and (4.8).} \end{aligned}$$

□

We are aiming to use Proposition 3.2.5 on the two components $\alpha_X \subset X$ and $\alpha_Y \subset Y$ of α to obtain lower bounds on their lengths. We hence need the following lemma to ensure us that when α is a geodesic, the exponential term in the inequality of Proposition 3.2.5 will be small.

Lemma 4.3.2. *Let $C = 2853\delta C_N + 2^{851}$ and let $e : \mathbb{R} \rightarrow \mathbb{R}$ be a map defined by $\forall t \in \mathbb{R}, e(t) = \frac{1}{C}2^{C^{-1}t} - 2 \max(0, t)$. Then $\forall t \in \mathbb{R}$:*

1. $e(t) \geq -7C^2$
2. $(e(t) \leq 2853\delta C_N) \Rightarrow (t \leq 3C^2)$.

Proof. For all time t , we have that $e(t) = \frac{1}{C}2^{C^{-1}t} - 2 \max(0, t) \leq \frac{1}{C}2^{C^{-1}t} - 2t =: e_1(t)$. The derivative of e_1 is $e_1'(t) = \frac{\log(2)}{C^2}2^{C^{-1}t} - 2$, which is non negative $\forall t \geq C \log_2\left(\frac{2}{\log(2)}C^2\right)$ and non positive otherwise.

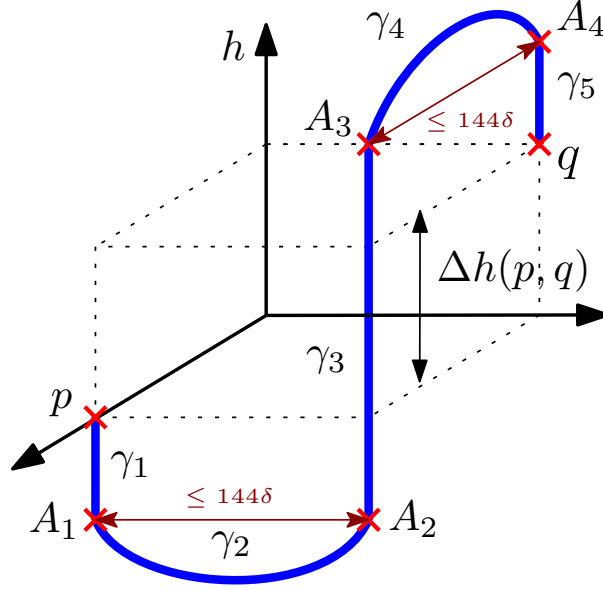

Figure 4.2: Construction of the path γ when $h(p) \leq h(q)$ for Lemma [4.3.1](#).

Then $\forall t \in \mathbb{R}$:

$$\begin{aligned} e_1(t) &\geq e_1\left(\log_2\left(\frac{2}{\log(2)}C^2\right)\right) \geq \frac{2C}{\log(2)} - 2C \log_2\left(\frac{2}{\log(2)}C^2\right) \geq \frac{2C}{\log(2)} - 4C \log_2\left(\sqrt{\frac{2}{\log(2)}}C\right) \\ &\geq \frac{2C}{\log(2)} - 4\sqrt{\frac{2}{\log(2)}}C^2 \geq -4\sqrt{\frac{2}{\log(2)}}C^2 \geq -7C^2. \end{aligned}$$

Since $C \geq \frac{2}{\log(2)}$ we have $3C^2 \geq C \log_2(C^3) \geq C \log_2\left(\frac{2}{\log(2)}C^2\right)$, then e_1 is non decreasing on $[C \log_2(C^3); +\infty[$. We show that $e_1(3C^2) \geq 2853\delta C_N$:

$$e_1(3C^2) \geq e_1(C \log_2(C^3)) = \frac{1}{C} 2^{\frac{C \log_2(C^3)}{C}} - 2C \log_2(C^3) = C(C - 6 \log_2(C)).$$

Since $C \geq 2^{851}$ we have $C - 6 \log_2(C) \geq 1$ and since $C \geq 2853\delta C_N$ we have that $e_1(3C^2) \geq C \times 1 \geq 2853\delta C_N$ which provides $\forall t \in [3C^2; +\infty[$ we have $e_1(t) \geq 2853\delta C_N$. Furthermore $\forall t \in \mathbb{R}^+$, $e_1(t) = e(t)$, hence $\forall t \in [3C^2; +\infty[$ we have $e(t) \geq 2853\delta C_N$ which implies point 2. of this lemma. \square

The following lemma provides us with a lower bound matching Lemma [4.3.1](#) and a first control on the heights a geodesic segment must reach.

Lemma 4.3.3. *Let $p = (p_X, p_Y)$ and $q = (q_X, q_Y)$ be two points of $X \bowtie Y$ such that $h(p) \leq h(q)$. Let $\alpha = (\alpha_X, \alpha_Y)$ be a geodesic segment of $X \bowtie Y$ linking p to q . Let $C_0 = (2853\delta C_N + 2^{851})^2$, we have:*

1. $l(\alpha) \geq \Delta h(p, q) + d_r(p_Y, q_Y) + d_r(p_X, q_X) - 15C_0$
2. $h^+(\alpha) \geq h(q) + \frac{1}{2}d_r(p_X, q_X) - 3C_0$
3. $h^-(\alpha) \leq h(p) - \frac{1}{2}d_r(p_Y, q_Y) + 3C_0$.

Proof. Let us denote $\Delta H^+ = h(q) + \frac{1}{2}d_r(p_X, q_X) - h^+(\alpha)$ and $\Delta H^- = h^-(\alpha) - (h(p) - \frac{1}{2}d_r(p_Y, q_Y))$. Let m be a point of α at height $h^-(\alpha) = h(p) - \frac{1}{2}d_r(p_Y, q_Y) + \Delta H^-$, and n be a point of α at height

$h^+(\alpha) = h(q) + \frac{1}{2}d_r(p_X, q_X) - \Delta H^+$. Then Proposition 3.2.5 used on α_X gives us:

$$\begin{aligned} l(\alpha_X) &\geq 2\Delta h(p_X, m_X) + d(p_X, q_X) + 2^{-850}2^{\frac{1}{\delta}\Delta H^+} - 1 - 2\max(0, \Delta H^+) - 1700\delta \\ &\geq 2h(p_X) - 2\left(h(p_X) - \frac{1}{2}d_r(p_Y, q_Y) + \Delta H^-\right) + d(p_X, q_X) + 2^{-850}2^{\frac{1}{\delta}\Delta H^+} - 1 \\ &\quad - 2\max(0, \Delta H^+) - 1700\delta \\ &\geq d_r(p_Y, q_Y) + d_r(p_X, q_X) + \Delta h(p, q) + 2^{-850}2^{\frac{1}{\delta}\Delta H^+} - 1 - 2\max(0, \Delta H^+) - 2\Delta H^- - 1700\delta. \end{aligned}$$

Since $h(p_Y) \geq h(q_Y)$ and $h(n_Y) = h(q_Y) - \frac{1}{2}d_r(p_X, q_X) + \Delta H^+$, Proposition 3.2.5 used on α_Y provides similarly:

$$l(\alpha_Y) \geq d_r(p_X, q_X) + d_r(p_Y, q_Y) + \Delta h(p, q) + 2^{-850}2^{\frac{1}{\delta}\Delta H^-} - 1 - 2\max(0, \Delta H^-) - 2\Delta H^+ - 1700\delta.$$

Hence by Property 4.1.4:

$$\begin{aligned} l_N(\alpha) &\geq \frac{1}{2}(l(\alpha_X) + l(\alpha_Y)) \geq d_r(p_X, q_X) + d_r(p_Y, q_Y) + \Delta h(p, q) - 1700\delta + 2^{-851}2^{\frac{1}{\delta}\Delta H^-} \\ &\quad + 2^{-851}2^{\frac{1}{\delta}\Delta H^+} - 2\max(0, \Delta H^-) - 2\max(0, \Delta H^+) - 1. \end{aligned} \quad (4.9)$$

Furthermore, we know by Lemma 4.3.1 that $l_N(\alpha) \leq \Delta h(p, q) + d_r(p_X, q_X) + d_r(p_Y, q_Y) + 1152\delta C_N$. Since $C_N \geq 1$ we have:

$$2852\delta C_N \geq 2^{-851}2^{\frac{1}{\delta}\Delta H^-} - 2\max(0, \Delta H^-) + 2^{-851}2^{\frac{1}{\delta}\Delta H^+} - 2\max(0, \Delta H^+) - 1.$$

Let us denote $S := \max\{\Delta H^-, \Delta H^+\}$. Therefore we have $2^{-851}2^{\frac{1}{\delta}S} - 2\max(0, S) - 1 \leq 2852\delta C_N$. By assumption $\delta \geq 1$ hence $2^{-851}2^{\frac{1}{\delta}S} - 2\max(0, S) \leq 2853\delta C_N$. Furthermore, for $C = 2853\delta C_N + 2^{851}$, we have both $2^{-851} \geq \frac{1}{C}$ and $\frac{1}{\delta} \geq \frac{1}{C}$. Then we have $\frac{1}{C}2^{\frac{S}{C}} - 2\max(0, S) \leq 2853\delta C_N$. Lemma 4.3.2 provides $S \leq 3C^2 = 3C_0$ which implies points 2. and 3. of our lemma. Lemma 4.3.2 also provides us with:

$$-14C_0 \leq 2^{-851}2^{\frac{1}{\delta}\Delta H^-} - 2\max(0, \Delta H^-) + 2^{-851}2^{\frac{1}{\delta}\Delta H^+} - 2\max(0, \Delta H^+).$$

Last inequality is a lower bound of the term we want to remove in inequality (4.9). The first point of our lemma hence follows since $1700\delta + 1 \leq C_0$. \square

We recall that by definition:

$$\begin{aligned} \forall p_X, q_X \in X, \quad d_r(p_X, q_X) &= d_X(p_X, q_X) - \Delta h(p_X, q_X) \\ \forall p_Y, q_Y \in Y, \quad d_r(p_Y, q_Y) &= d_Y(p_Y, q_Y) - \Delta h(p_Y, q_Y) \end{aligned}$$

Hence combining Lemma 4.3.1 and 4.3.3 we get the following corollary.

Corollary 4.3.4. *Let N be an admissible norm and let $C_0 = (2853\delta C_N + 2^{851})^2$. The length of a geodesic segment α connecting p to q in $(X \rtimes Y, d_\rtimes)$ is controlled as follows:*

$$|l_N(\alpha) - (d_X(p_X, q_X) + d_Y(p_Y, q_Y) - \Delta h(p, q))| \leq 15C_0,$$

which gives us a control on the N -path metric, for all points p and q in $X \rtimes Y$ we have:

$$|d_\rtimes(p, q) - (d_X(p_X, q_X) + d_Y(p_Y, q_Y) - \Delta h(p, q))| \leq 15C_0.$$

This result is central as it shows that the shape of geodesics does not depend on the N -path metric chosen for the distance on the horospherical product.

Corollary 4.3.5. *Let $r \geq 1$. For all p and q in $X \rtimes Y$ we have:*

$$|d_{\rtimes, \ell_r}(p, q) - d_{\rtimes, \ell_1}(p, q)| \leq 30(5706\delta + 2^{851})^2.$$

Proof. The ℓ_r norm inequalities provide us with:

$$\sqrt[r]{d_X^r + d_Y^r} \leq d_X + d_Y \leq 2^{\frac{r-1}{r}} \sqrt[r]{d_X^r + d_Y^r}.$$

Hence we have $\frac{\sqrt[r]{2}}{2} (d_X + d_Y) \leq \sqrt[r]{d_X^r + d_Y^r} \leq d_X + d_Y$. Then the ℓ_r norms are admissible norms with $C_{\ell_r} \leq 2$, which ends the proof. \square

The next corollary tells us that changing this distance does not change the large scale geometry of $X \rtimes Y$.

Corollary 4.3.6. *Let N_1 and N_2 be two admissible norms. Then the metric spaces $(X \rtimes Y, d_{\rtimes, N_1})$ and $(X \rtimes Y, d_{\rtimes, N_2})$ are roughly isometric.*

The control on the distances of Lemma 4.3.4 will help us understand the shape of geodesic segments and geodesic lines in a horospherical product.

Chapter 5

Shapes of geodesics and visual boundary of $X \rtimes Y$

5.1 Shapes of geodesic segments

In this section we focus on the shape of geodesics. We recall that in all the following X and Y are assumed to be two proper, geodesically complete, δ -hyperbolic, Busemann spaces with $\delta \geq 1$, and N is assumed to be an admissible norm.

The next lemma gives a control on the maximal and minimal height of a geodesic segment in a horospherical product. It is similar to the traveling salesman problem, who needs to walk from x to y passing by m and n . This result follows from the inequalities on maximal and minimal heights of Lemma 4.3.3 combined with Lemma 4.3.1

Lemma 5.1.1. *Let $p = (p_X, p_Y)$ and $q = (q_X, q_Y)$ be two points of $X \rtimes Y$ such that $h(p) \leq h(q)$. Let N be an admissible norm and let $\alpha = (\alpha_X, \alpha_Y)$ be a geodesic of $(X \rtimes Y, d_\star)$ linking p to q . Let $C_0 = (2853\delta C_N + 2^{851})^2$, we have:*

1. $|h^-(\alpha) - (h(p) - \frac{1}{2}d_r(p_Y, q_Y))| \leq 4C_0$
2. $|h^+(\alpha) - (h(q) + \frac{1}{2}d_r(p_X, q_X))| \leq 4C_0$.

Proof. Let us consider a point m of α such that $h(m) = h^-(\alpha)$ and a point n of α such that $h(n) = h^+(\alpha)$. Then m comes before n or n comes before m . In both cases, since $h(m) \leq h(p) \leq h(q) \leq h(n)$ and by Lemma 4.1.6 we have:

$$\begin{aligned} l_N(\alpha) &\geq \Delta h(p, q) + 2(h(p) - h^-(\alpha)) + 2(h^+(\alpha) - h(q)) \\ &\geq \Delta h(p, q) + 2(h(p) - h^-(\alpha)) + d_r(p_X, q_X) - 6C_0, \text{ by Lemma 4.3.3.} \end{aligned}$$

Furthermore Lemma 4.3.1 provides $l_N(\alpha) \leq \Delta h(p, q) + d_r(p_X, q_X) + d_r(p_Y, q_Y) + C_0$, hence:

$$\Delta h(p, q) + d_r(p_X, q_X) + d_r(p_Y, q_Y) + C_0 \geq \Delta h(p, q) + 2(h(p) - h^-(\alpha)) + d_r(p_X, q_X) - 6C_0,$$

which implies $(h(p) - \frac{1}{2}d_r(p_Y, q_Y)) - h^-(\alpha) \leq 4C_0$. In combination with the third point of Lemma 4.3.3 it proves the first point of our Lemma 5.1.1. The second point is proved similarly. \square

Lemma 5.1.2. *Let N be an admissible norm and let $C_0 = (2853\delta C_N + 2^{851})^2$. Let $p = (p_X, p_Y)$ and $q = (q_X, q_Y)$ be two points of $X \rtimes Y$. Let $\alpha = (\alpha_X, \alpha_Y)$ be a geodesic of $(X \rtimes Y, d_\star)$ linking p to q . Then there exist two points $a = (a_X, a_Y)$, $b = (b_X, b_Y)$ of α such that $h(a) = h(p)$, $h(b) = h(q)$ with the following properties:*

1. If $h(p) \leq h(q) - 7C_0$ then:
 - (a) $h^-(\alpha) = h^-([x, a])$ and $h^+(\alpha) = h^+([b, y])$

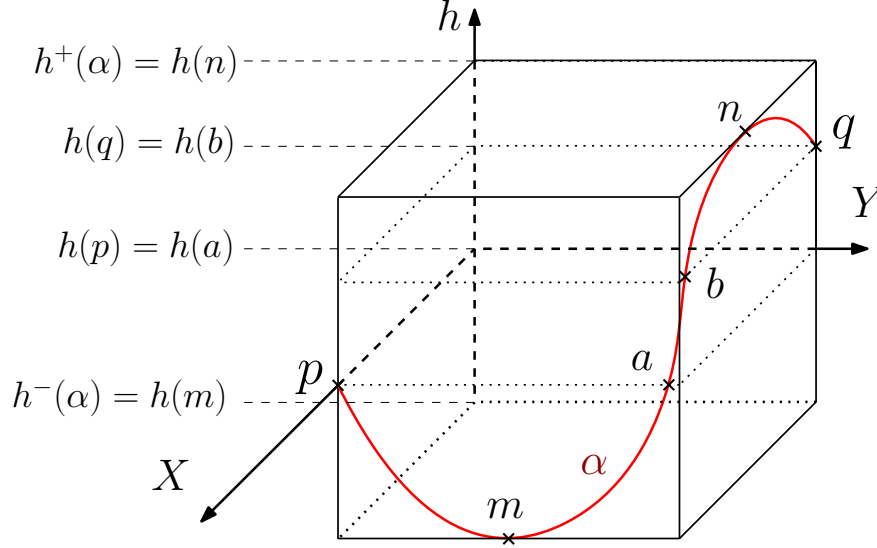

Figure 5.1: Notations of Lemma 5.1.2

- (b) $|d_r(p_Y, a_Y) - d_r(p_Y, q_Y)| \leq 16C_0$ and $d_r(p_X, a_X) \leq 22C_0$
- (c) $|d_r(q_X, b_X) - d_r(p_X, q_X)| \leq 16C_0$ and $d_r(q_Y, b_Y) \leq 22C_0$
- (d) $|d_{\bowtie}(a, b) - \Delta h(a, b)| \leq 13C_0$.

2. If $h(q) \leq h(p) - 7C_0$ then (a), (b), (c) and (d) hold by switching the roles of p and q and switching the roles of a and b .
3. If $|h(p) - h(q)| \leq 7C_0$ at least one of the two previous conclusions is satisfied.

Lemma 5.1.2 is illustrated in Figure 5.1. Its notations will be used in all section 5.

Proof. Let us consider a point m of α such that $h(m) = h^-(\alpha)$ and a point n of α such that $h(n) = h^+(\alpha)$. We first assume that m comes before n in α oriented from p to q . Let us call a the first point between m and n at height $h(p)$ and b the last point between m and n at height $h(q)$. Property (a) of our Lemma is then satisfied. Let us denote α_1 the part of α linking p to a , α_2 the part of α linking a to b and α_3 the part of α linking b to q . We have that m is a point of α_1 and that n is a point of α_3 . Inequalities 2. and 3. of Lemma 4.3.3 used on α_1 provide $l_N(\alpha_1) \geq d(p, m) + d(m, a) \geq 2\Delta h(p, m) \geq d_r(p_Y, q_Y) - 6C_0$ and similarly $l_N(\alpha_3) \geq d_r(p_X, q_X) - 6C_0$. Furthermore we have $l_N(\alpha_2) \geq \Delta h(p, q)$. Combining $l_N(\alpha_1) = l_N(\alpha) - l_N(\alpha_2) - l_N(\alpha_3)$ and Lemma 4.3.1 we have:

$$\begin{aligned} l_N(\alpha_1) &\leq \Delta h(p, q) + d_r(p_X, q_X) + d_r(p_Y, q_Y) + C_0 - \Delta h(p, q) - d_r(p_X, q_X) + 6C_0 \\ &\leq d_r(p_Y, q_Y) + 7C_0. \end{aligned} \tag{5.1}$$

We have similarly that $l_N(\alpha_3) \leq d_r(p_X, q_X) + 7C_0$ and that $d_{\bowtie}(a, b) = l_N(\alpha_2) \leq \Delta h(p, q) + 13C_0$. It gives us $|d_{\bowtie}(a, b) - \Delta h(p, q)| \leq 13C_0$, point (d) of our lemma. Furthermore, using Lemma 5.1.1 on α and α_1 provides:

$$\begin{aligned} \left| h^-(\alpha) - \left(h(p) - \frac{1}{2}d_r(p_Y, q_Y) \right) \right| &\leq 4C_0, \\ \left| h^-(\alpha_1) - \left(h(p) - \frac{1}{2}d_r(p_Y, a_Y) \right) \right| &\leq 4C_0. \end{aligned}$$

Since $h^-(\alpha) = h^-(\alpha_1)$ we have:

$$|d_r(p_Y, a_Y) - d_r(p_Y, q_Y)| \leq 16C_0, \tag{5.2}$$

which is the first inequality of (b). Using the first point of Lemma 4.3.3 on α_1 in combination with inequality (5.1) gives us:

$$\begin{aligned} d_r(p_Y, q_Y) + 7C_0 &\geq l_N(\alpha_1) \geq \Delta h(p, a) + d_r(p_X, a_X) + d_r(p_Y, a_Y) - 15C_0 \\ &\geq d_r(p_X, a_X) + d_r(p_Y, a_Y) - 15C_0 \\ &\geq d_r(p_X, a_X) + d_r(p_Y, q_Y) - 31C_0, \text{ by inequality (5.2).} \end{aligned}$$

Then $d_r(p_X, q_X) \leq 38C_0$ the second inequality of point (b) holds. We prove similarly the inequality (c) of this lemma. This ends the proof when m comes before n . If n comes before m , the proof is still working by orienting α from q to p hence switching the roles between p and q .

We will now prove that if $h(p) \leq h(q) - 7C_0$ then m comes before n on α oriented from p to q . Let us assume that $h(p) \leq h(q) - 7C_0$. We will proceed by contradiction, let us assume that n comes before m , using $h(m) \leq h(p) \leq h(q) \leq h(n)$ it implies:

$$\begin{aligned} l_N(\alpha) &\geq d_{\ast}(p, n) + d_{\ast}(n, m) + d_{\ast}(m, q) \geq \Delta h(p, n) + \Delta h(n, m) + \Delta h(m, q) \\ &\geq \Delta h(p, q) + \Delta h(q, n) + \Delta h(m, p) + \Delta h(p, q) + \Delta h(q, n) + \Delta h(m, p) + \Delta h(p, q) \\ &\geq 2\Delta h(p, q) + \Delta h(p, q) + 2\Delta h(m, p) + 2\Delta h(q, n) \\ &\geq 14C_0 + \Delta h(p, q) + 2(h(p) - h^-(\alpha)) + 2(h^+(\alpha) - h(q)). \end{aligned}$$

However Lemma 4.3.3 applied on α provides $h^+(\alpha) \geq h(q) + \frac{1}{2}d_r(p_X, q_X) - 3C_0$ and $h^-(\alpha) \leq h(p) - \frac{1}{2}d_r(p_Y, q_Y) + 3C_0$. Then:

$$\begin{aligned} l_N(\alpha) &\geq 14C_0 + \Delta h(p, q) + d_r(p_X, q_X) + d_r(p_Y, q_Y) - 12C_0 \\ &\geq \Delta h(p, q) + d_r(p_X, q_X) + d_r(p_Y, q_Y) + 2C_0, \end{aligned}$$

which contradict Lemma 4.3.1. Hence, if $h(p) \leq h(q) - 7C_0$, the point m comes before the point n and by the first part of the proof, 1. holds. Similarly, if $h(q) \leq h(p) - 7C_0$ then n comes before m and then 2. holds. Otherwise when $|h(p) - h(q)| \leq 7C_0$ both cases could happened, then 1. or 2. hold. \square

This previous lemma essentially means that if p is sufficiently below q , the geodesic α first travels in a copy of Y in order to "lose" the relative distance between p_Y and q_Y , then it travels upward using a vertical geodesic from a to b until it can "lose" the relative distance between p_X and q_X by travelling in a copy of X . It looks like three successive geodesics of hyperbolic spaces, glued together. The idea is that the geodesic follows a shape similar to the path γ we constructed in Lemma 4.3.1. The following theorem tells us that a geodesic segment is in the constant neighbourhood of three vertical geodesics. It is similar to the hyperbolic case, where a geodesic segment is in a constant neighbourhood of two vertical geodesics.

Theorem 5.1.3. *Let N be an admissible norm. Let $p = (p_X, p_Y)$ and $q = (q_X, q_Y)$ be two points of $X \ast Y$ and let α be a geodesic segment of $(X \ast Y, d_{\ast})$ linking p to q . Let $C_0 = (2853\delta C_N + 2^{851})^2$, there exist two vertical geodesics $V_1 = (V_{1,X}, V_{1,Y})$ and $V_2 = (V_{2,X}, V_{2,Y})$ such that:*

1. If $h(p) \leq h(q) - 7C_0$ then α is in the $196C_0C_N$ -neighbourhood of $V_1 \cup (V_{1,X}, V_{2,Y}) \cup V_2$
2. If $h(p) \geq h(q) + 7C_0$ then α is in the $196C_0C_N$ -neighbourhood of $V_1 \cup (V_{2,X}, V_{1,Y}) \cup V_2$
3. If $|h(p) - h(q)| \leq 7C_0$ then at least one of the conclusions of 1. or 2. holds.

Specifically V_1 and V_2 can be chosen such that p is close to V_1 and q is close to V_2 .

Figure 5.2 pictures the $196C_0C_N$ -neighbourhood of such vertical geodesics when $h(p) \leq h(q) - 7C_0$. When $|h(p) - h(q)| \leq 7C_0$, there are two possible shapes for a geodesic segment. In some cases, two points can be linked by two different geodesics, one of type 1 and one of type 2.

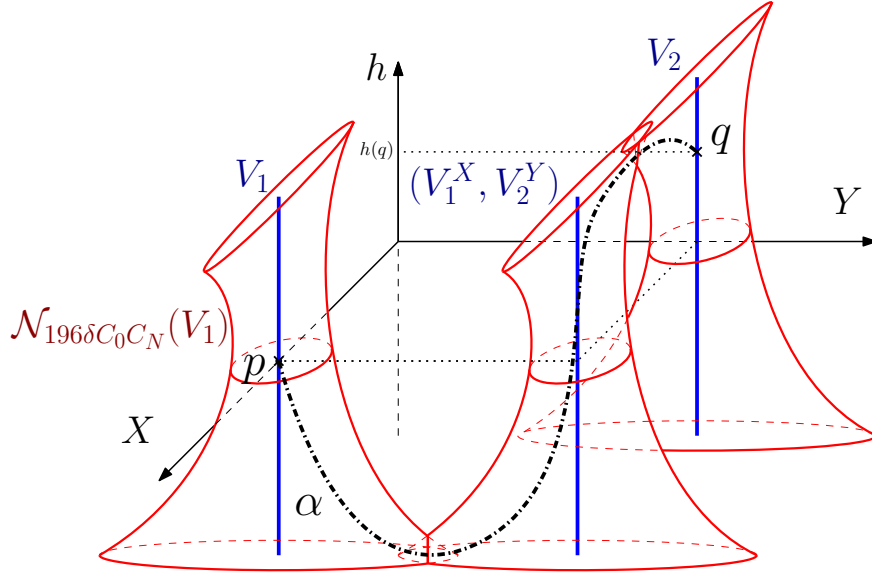

Figure 5.2: Theorem [5.1.3](#). The neighbourhood's shapes are distorted since when going upward, distances are contracted in the "direction" X and expanded in the "direction" Y .

Proof. Let $m = (m_X, m_Y)$ be a point of α such that $h(m) = h^-(\alpha)$, and $n = (n_X, n_Y)$ be a point of α such that $h(n) = h^+(\alpha)$. Then by Lemma [5.1.1](#) we have:

$$\left| \Delta h(p, m) - \frac{1}{2} d_r(p_Y, q_Y) \right| \leq 4C_0. \quad (5.3)$$

We show similarly that:

$$\left| \Delta h(q, n) - \frac{1}{2} d_r(p_X, q_X) \right| \leq 4C_0. \quad (5.4)$$

In the first case we assume that $h(p) \leq h(q) - 7C_0$. With notations as in Lemma [5.1.2](#), and by inequality [\(5.1\)](#), we have that $l_N([p, a]) \leq d_r(p_Y, q_Y) + 7C_0$, hence:

$$\begin{aligned} l_N([p, m]) &= l_N([p, a]) - l_N([a, m]) \leq d_r(p_Y, q_Y) + 7C_0 - \Delta h(a, m) \\ &\leq \frac{1}{2} d_r(p_Y, q_Y) + 11C_0, \text{ since } \Delta h(p, m) = \Delta h(a, m). \end{aligned} \quad (5.5)$$

It follows from this inequality that:

$$\begin{aligned} d_X(p_X, m_X) &= 2d_{X \times Y}(p, m) - d_Y(p_Y, m_Y) \leq 2d_N(p, m) - d_Y(p_Y, m_Y) \\ &\leq 2l_N([p, m]) - d_Y(p_Y, m_Y) \leq d_r(p_Y, q_Y) + 22C_0 - \Delta h(p, m) \leq \frac{1}{2} d_r(p_Y, q_Y) + 26C_0. \end{aligned}$$

Then:

$$\begin{aligned} d_r(p_X, m_X) &= d_X(p_X, m_X) - \Delta h(p, m) \leq \frac{1}{2} d_r(p_Y, q_Y) + 26C_0 - \Delta h(p, m) \\ &\leq 30C_0, \text{ by inequality } \text{\a href="#">(5.3)}. \end{aligned}$$

Similarly $d_r(p_Y, m_Y) \leq 30C_0$. Let us consider the vertical geodesic V_{m_X} of X containing m_X , and the vertical geodesic V_{p_Y} of Y containing p_Y . Let us denote p'_X the point of V_{m_X} at the height $h(p)$. Since $d_r(p_X, m_X) \leq 30C_0$, Lemma [3.1.3](#) applied on p_X and m_X provides $d_X(p_X, p'_X) \leq 31C_0$. We will then consider two paths of X . The first one is $\alpha_{1,X} = [p_X, m_X]$, the part of α_X linking p_X to m_X . The

second one is $[m_X, p'_X]$ a piece of vertical geodesic linking m_X to p'_X . We show that these two paths have close length. Using Property 4.1.4 with inequalities (5.3) and (5.5) provides us with:

$$\begin{aligned} l_X([p_X, m_X]) &\leq 2l_N([p, m]) - l_Y([p_Y, m_Y]) \leq 2\left(\frac{1}{2}d_r(p_Y, q_Y) + 11C_0\right) - \Delta h(p, m) \\ &\leq \Delta h(p, m) + 30C_0 \end{aligned}$$

Furthermore $l_X([p_X, m_X]) \geq \Delta h(p, m)$ and we know that $l_X([m_X, p'_X]) = \Delta h(p, m)$, hence:

$$|l_X([p_X, m_X]) - l_X([m_X, p'_X])| \leq 30C_0$$

We already proved that their end points are also close to each other $d(p_X, p'_X) \leq 31C_0$. Since $\delta \leq C_0$, the property of hyperbolicity of X gives us that $\alpha_{1,X}$ is in the $(31+30+1)C_0 = 62C_0$ -neighbourhood of $[m_X, p'_X]$, a part of the vertical geodesic V_{m_X} . We show similarly that $\alpha_{1,Y}$ is in the $62C_0$ -neighbourhood of V_{p_Y} . Since N is an admissible norm, Property 4.1.11 gives us that α_1 is in the $124C_0C_N$ -neighbourhood of (V_{m_X}, V_{p_Y}) . We show similarly that α_3 , the portion of α linking n to q , is in the $124C_0C_N$ -neighbourhood of (V_{q_X}, V_{n_Y}) . We now focus on α_2 , the portion of α linking m to n . Let us denote $[m_X, n_X]$ the path $\alpha_{2,X}$ and $[m_Y, n_Y]$ the path $\alpha_{2,Y}$. Then Lemma 5.1.1 provides us with:

$$\left| \Delta h(m, n) - \left(\Delta h(p, q) + \frac{1}{2}d_r(p_Y, q_Y) + \frac{1}{2}d_r(p_X, q_X) \right) \right| \leq 8C_0. \quad (5.6)$$

However from Lemma 4.3.1 and since $1152\delta C_N \leq C_0$:

$$\begin{aligned} l_N(\alpha_2) &= l_N(\alpha) - l_N(\alpha_1) - l_N(\alpha_3) \\ &\leq \Delta h(p, q) + d_r(p_X, q_X) + d_r(p_Y, q_Y) + C_0 - \Delta h(p, m) - \Delta h(n, q) \\ &\leq \Delta h(p, q) + \frac{1}{2}d_r(p_X, q_X) + \frac{1}{2}d_r(p_Y, q_Y) + 9C_0, \text{ by inequalities (5.3) and (5.4)}. \end{aligned}$$

It follows from this inequality and the fact that N is admissible that:

$$\begin{aligned} d_X(m_X, n_X) &\leq 2l_N(\alpha_2) - d_Y(m_Y, n_Y) \leq 2\Delta h(p, q) + d_r(p_X, q_X) + d_r(p_Y, q_Y) + 18C_0 - \Delta h(m, n) \\ &\leq \Delta h(m, n) + 34C_0, \text{ by inequality (5.6)}. \end{aligned}$$

Thus:

$$d_r(m_X, n_X) = d_X(m_X, n_X) - \Delta h(m, n) \leq 34C_0.$$

In the same way we have $d_r(m_Y, n_Y) \leq 34C_0$. Let us denote n'_X the point of V_{m_X} at the height $h(n_X)$. Since $d_r(p_X, m_X) \leq 34C_0$, Lemma 3.1.3 applied on m_X and n_X provides:

$$d_X(m_X, n'_X) \leq 35C_0 \quad (5.7)$$

Hence we have proved that $\alpha_{2,X}$ and $[m_X, n'_X]$ have their end points close to each other. Let us now prove that these paths have close lengths. We have that $l_X([m_X, n'_X]) = \Delta h(m, n)$, and from inequalities (5.3) and (5.4) we have:

$$\begin{aligned} l_X([m_X, n_X]) &\leq 2l_N(\alpha_{2,X}) - l_Y([m_Y, n_Y]) = 2\left(l_N(\alpha) - l_N(\alpha_1) - l_N(\alpha_3)\right) - \Delta h(m, n) \\ &\leq 2\left(15C_0 + \Delta h(p, q) + d_r(p_X, q_X) + d_r(p_Y, q_Y) - \Delta h(p, m) - \Delta h(n, q)\right) - \Delta h(m, n) \\ &\leq 2\left(\Delta h(p, q) + d_r(p_X, q_X) + d_r(p_Y, q_Y) - \Delta h(p, m) - \Delta h(n, q)\right) - \Delta h(m, n) \\ &\leq 2\left(\Delta h(p, q) + \Delta h(p, m) + \Delta h(n, q) + 16C_0\right) - \Delta h(m, n) + 30C_0 \leq \Delta h(m, n) + 62C_0 \end{aligned}$$

As $l_X([m_X, n_X]) \geq \Delta h(m, n)$ we obtain:

$$|l_X([m_X, n_X]) - l_X([m_X, n'_X])| \leq 62C_0 \quad (5.8)$$

Then by similar arguments as for the path $\alpha_{1,X}$, inequalities (5.7) and (5.8) show that $\alpha_{2,X}$ is in the $(35 + 62 + 1)C_0 = 98C_0$ neighbourhood of V_{m_X} . Similarly we prove that $\alpha_{2,Y}$ is in the $98C_0$ neighbourhood of V_{n_Y} . Since N is an admissible norm, Property 4.1.11 gives us that α_2 is in the $196C_0C_N$ -neighbourhood of (V_{m_X}, V_{n_Y}) .

In the second case, we assume that $h(q) \leq h(p) - 7C_0$. Then by switching the role of p and q , Lemma 5.1.2 gives us the result identically.

In the third case, we assume that $|h(p) - h(q)| \leq 7C_0$. Then Lemma 5.1.2 tells us that one of the two previous situations prevail, which proves the result. \square

5.2 Coarse monotonicity

We will see that the following definition is related to being close to a vertical geodesic.

Definition 5.2.1. Let C be a non negative number. A geodesic $\alpha : I \rightarrow X \rtimes Y$ of $X \rtimes Y$ is called C -coarsely increasing if $\forall t_1, t_2 \in I$:

$$(t_2 > t_1 + C) \Rightarrow (h(\alpha(t_2)) > h(\alpha(t_1))).$$

The geodesic α is called C -coarsely decreasing if $\forall t_1, t_2 \in I$:

$$(t_2 > t_1 + C) \Rightarrow (h(\alpha(t_2)) < h(\alpha(t_1))).$$

The next lemma links the coarse monotonicity and the fact that a geodesic segment is close to vertical geodesics.

Lemma 5.2.2. Let N be an admissible norm and let $C_0 = (2853\delta C_N + 2^{851})^2$. Let $p = (p_X, p_Y)$ and $q = (q_X, q_Y)$ be two points of $X \rtimes Y$ and let α be a geodesic segment of $(X \rtimes Y, d_\rtimes)$ linking p to q . Let $m \in \alpha$ and $n \in \alpha$ be two points in $X \rtimes Y$ such that $h^-(\alpha) = h(m)$ and $h^+(\alpha) = h(n)$. We have:

1. If $h(p) \leq h(q) - 7C_0$, then α is $17C_0$ -coarsely decreasing on $[p, m]$ and $17C_0$ -coarsely increasing on $[m, n]$ and $17C_0$ -coarsely decreasing on $[n, q]$.
2. If $h(p) \geq h(q) + 7C_0$, then α is $17C_0$ -coarsely increasing on $[p, n]$ and $17C_0$ -coarsely decreasing on $[n, m]$ and $17C_0$ -coarsely increasing on $[m, q]$.
3. If $|h(p) - h(q)| \leq 7C_0$ then the conclusions of 1. or 2. holds.

Proof. Assume that $h(p) \leq h(q) - 7C_0$. Then from inequality (5.5) in the proof of Theorem 5.1.3 $l_N([p, m]) \leq \frac{1}{2}d_r(p_Y, q_Y) + 11C_0$. Furthermore Lemma 5.1.1 gives us that $|\Delta h(p, m) - \frac{1}{2}d_r(p_Y, q_Y)| \leq 4C_0$. Then:

$$l_N([p, m]) \leq \Delta h(p, m) + 15C_0. \tag{5.9}$$

We will proceed by contradiction, assume that $[p, m]$ is not $15C_0$ -coarsely decreasing, then there exists $i_1 \in \alpha$, $i_2 \in \alpha$ such that $h(i_1) = h(i_2)$ and $l([i_1, i_2]) > 15C_0$. Hence:

$$\begin{aligned} l_N([p, m]) &\geq l_N([p, i_1]) + l_N([i_1, i_2]) + l_N([i_2, m]) \geq \Delta h(p, i_1) + l_N([i_1, i_2]) + \Delta h(i_2, m) \\ &> \Delta h(p, m) + 15C_0, \end{aligned}$$

which contradicts inequality (5.9). Then $[p, m]$ is $15C_0$ -coarsely decreasing. We show in a similar way that $[m, n]$ is $17C_0$ -coarsely increasing and that $[n, q]$ is $15C_0$ -coarsely decreasing. This proves the first point of our lemma. The second point is proved by switching the roles of p and q . We now assume $|h(p) - h(q)| \leq 7C_0$, as in the proof of Theorem 5.1.3 the inequality (5.5) or a corresponding inequality holds, which ends the proof. \square

5.3 Shapes of geodesic rays and geodesic lines

In this section we are focusing on using the previous results to get informations on the shapes of geodesic rays and geodesic lines. We first link the coarse monotonicity of a geodesic ray to the fact that it is close to a vertical geodesic. Let $\lambda \geq 1$ and $c \geq 0$, a (λ, c) -quasigeodesic of the metric space $(X \bowtie Y, d_{\bowtie})$ is the image of a function $\phi : \mathbb{R} \rightarrow X \bowtie Y$ verifying that $\forall t_1, t_2 \in \mathbb{R}$:

$$\frac{|t_1 - t_2|}{\lambda} - c \leq d_{\bowtie}(\phi(t_1), \phi(t_2)) \leq \lambda|t_1 - t_2| + c \quad (5.10)$$

Lemma 5.3.1. *Let N be an admissible norm and let $C_0 = (2853\delta C_N + 2^{851})^2$. Let $\alpha = (\alpha_X, \alpha_Y)$ be a geodesic ray of $(X \bowtie Y, d_{\bowtie})$ and let K be a positive number such that α is K -coarsely monotone. Then α_X and α_Y are $(1, 26C_0 + 8K)$ -quasigeodesics.*

Proof. Let t_1 and t_2 be two times. Let us denote $p = (p_X, p_Y) = \alpha(t_1)$ and $q = (q_X, q_Y) = \alpha(t_2)$. We apply Lemma 5.1.2 on the part of α linking p to q denoted by $[p, q]$. By K -coarse monotonicity of α we have that $d(p, a)_{X \bowtie Y, N} \leq K$ and $d_{\bowtie}(b, q) \leq K$. Hence using d of Lemma 5.1.2:

$$\begin{aligned} \Delta h(p, q) &\leq d_{\bowtie}(p, q) \leq d_{\bowtie}(p, a) + d_{\bowtie}(a, b) + d_{\bowtie}(b, q) \leq K + \Delta h(a, b) + 13C_0 + K \\ &\leq \Delta h(p, q) + \Delta h(p, a) + \Delta h(b, q) + 13C_0 + 2K \leq \Delta h(p, q) + 13C_0 + 4K. \end{aligned}$$

Furthermore, $d_X(p_X, q_X) \geq \Delta h(p_X, q_X) = \Delta h(p, q)$ and $d_Y(p_Y, q_Y) \geq \Delta h(p, q)$. Since N is an admissible norm we have:

$$\begin{aligned} \Delta h(p, q) &\leq d_X(p_X, q_X) = 2d_{X \times Y}(p, q) - d_Y(p_Y, q_Y) \leq 2d_{\bowtie}(p, q) - d_Y(p_Y, q_Y) \\ &\leq 2\Delta h(p, q) + 13C_0 + 4K - \Delta h(p, q) \leq \Delta h(p, q) + 13C_0 + 4K. \end{aligned}$$

Hence:

$$d_{\bowtie}(p, q) - 26C_0 - 8K \leq d_X(p_X, q_X) \leq d_{\bowtie}(p, q) + 26C_0 + 8K,$$

By definition we have $p_X = \alpha_X(t_1)$, $q_X = \alpha_X(t_2)$ and $d_{\bowtie}(p, q) = |t_1 - t_2|$. Then α_X is a $(1, 26C_0 + 8K)$ -quasigeodesic ray. We prove similarly that α_Y is a $(1, 26C_0 + 8K)$ -quasigeodesic ray. \square

We will now make use of the rigidity property of quasi-geodesics in Gromov hyperbolic spaces, presented in Theorem 3.1 p.41 of [5, Coornaert, Delzant, Papadopoulos].

Theorem 5.3.2 ([5]). *Let H be a δ -hyperbolic geodesic space. If $f : \mathbb{R} \rightarrow H$ is a (λ, k) -quasi geodesic, then there exists a constant $\kappa > 0$ depending only on δ, λ and k such that the image of f is in the κ -neighbourhood of a geodesic in H .*

Lemma 5.3.3. *Let N be an admissible norm and let T_1 and T_2 be two real numbers. Let $\alpha = (\alpha_X, \alpha_Y) : [T_1, +\infty[\rightarrow X \bowtie Y$ be a geodesic ray of $(X \bowtie Y, d_{\bowtie})$. Let K be a positive number such that α is K -coarsely monotone. Then there exists a constant $\kappa > 0$ depending only on K, δ and N such that α is in the κ -neighbourhood of a vertical geodesic ray $V : [T_2; +\infty[\rightarrow X \bowtie Y$ and such that $d_{\bowtie}(\alpha(T_1), V(T_2)) \leq \kappa$.*

Proof. We assume without loss of generality that $\lim_{t \rightarrow +\infty} h(\alpha(t)) = +\infty$. Let $C_0 = (2853\delta C_N + 2^{851})^2$, by Lemma 5.3.1, α_X is a $(1, 26C_0 + 8K)$ -quasi geodesic ray. Then Theorem 5.3.2 says there exists $\kappa_X > 0$ depending only on $26C_0 + 8K$ and δ such that α_X is in the κ_X -neighbourhood of a geodesic V_X . Since C_0 depends only on δ and N , κ_X depends only on K, δ and N . Then $\lim_{t \rightarrow +\infty} h(\alpha(t)) = +\infty$ gives us $\lim_{t \rightarrow +\infty} h(V_X(t)) = +\infty$ which implies that V_X is a vertical geodesic of X . We will now build the vertical geodesic we want in Y . We have $\lim_{t \rightarrow +\infty} h(\alpha_Y(t)) = -\infty$ and by Lemma 5.3.1:

$$\Delta h(\alpha_Y(t_1), \alpha_Y(t_2)) - 26C_0 - 8K \leq d_Y(\alpha_Y(t_1), \alpha_Y(t_2)) \leq \Delta h(\alpha_Y(t_1), \alpha_Y(t_2)) + 26C_0 + 8K.$$

Since Y is Busemann, there exists a vertical geodesic ray β starting at $\alpha_Y(T_1)$. Since β is parametrised by its height, $\alpha_Y \cup \beta$ is also a $(1, 26C_0 + 8K)$ -quasi geodesic, hence there exists κ_Y and V_Y depending only on K , δ and N such that $\alpha_Y \cup \beta$ is in the κ_Y -neighbourhood of V_Y . Since $\lim_{t \rightarrow -\infty} h(V_Y(t)) = +\infty$, V_Y is a vertical geodesic of Y .

Furthermore, by Property 4.1.11, $d_{\rtimes} \leq 2C_N(d_X + d_Y)$, hence there exists κ depending only on K , δ and N such that α is in the κ -neighbourhood (for d_{\rtimes}) of (V_X, V_Y) , a vertical geodesic of $(X \rtimes Y, d_{\rtimes})$. Since $h(\alpha(t)) \geq h(\alpha(T_1)) - 26C_0 - 8K =: M$, α is in the κ -neighbourhood of $(V_X([M - \kappa; +\infty[), V_Y(-\infty; -M + \kappa]))$ which is a vertical geodesic ray.

We will now show that the starting points of α and V are close to each other. Let us denote T'_1 a time such that $d_{\rtimes}(\alpha(T_1), V(T'_1)) \leq \kappa$, then $\Delta h(\alpha(T_1), V(T'_1)) \leq \kappa$, hence $|T'_1 - M| \leq 26C_0 + 8K + \kappa$. Then by the triangle inequality:

$$\begin{aligned} d_{\rtimes}(\alpha(T_1), V(M - \kappa)) &\leq d_{\rtimes}(\alpha(T_1), V(T'_1)) + d_{\rtimes}(V(T'_1), V(M - \kappa)) \\ &\leq \kappa + 26C_0 + 8K + \kappa + \kappa = 26C_0 + 8K + 3\kappa \end{aligned}$$

Let us denote $\kappa' := 26C_0 + 8K + 3\kappa \geq \kappa$ and $T_2 := M - \kappa$. Hence $\alpha : [T_1; +\infty[\rightarrow X \rtimes Y$ is in the κ' -neighbourhood of a vertical geodesic ray $V : [T_2; +\infty[\rightarrow X \rtimes Y$, we have $d_{\rtimes}(\alpha(T_1), V(T_2)) \leq \kappa'$ and κ' depends only on δ and K . \square

Lemma 5.3.4. *Let N be an admissible norm and let $\alpha : \mathbb{R}^+ \rightarrow X \rtimes Y$ be a geodesic ray of $(X \rtimes Y, d_{\rtimes})$. Then α changes its $17C_0$ -coarse monotonicity at most once.*

Proof. Let $\alpha : \mathbb{R}^+ \rightarrow X \rtimes Y$ be a geodesic ray. Thanks to Lemma 5.2.2 α changes at most twice of $17C_0$ -coarse monotonicity. Indeed, assume it changes three times, applying Lemma 5.2.2 on the geodesic segment which includes these three times provides a contradiction. We will show in the following that it actually only changes once.

Assume α changes twice of $17C_0$ -coarse monotonicity. Then α must be first $17C_0$ -coarsely increasing or $17C_0$ -coarsely decreasing. We assume without loss of generality that α is first $17C_0$ -coarsely decreasing. Then there exist $t_1, t_2, t_3 \in \mathbb{R}$ such that α is $17C_0$ -coarsely decreasing on $[\alpha(t_1), \alpha(t_2)]$ then $17C_0$ -coarsely increasing on $[\alpha(t_2), \alpha(t_3)]$ then $17C_0$ -coarsely decreasing on $[\alpha(t_3), \alpha(+\infty[$. Hence Lemma 5.3.3 applied on $[\alpha(t_3), \alpha(+\infty[$ implies that there exists $\kappa > 0$ depending only on δ (since the constant of coarse monotonicity depends only on δ) and a vertical geodesic ray $V = (V_X, V_Y)$ such that $[\alpha(t_3), \alpha(+\infty[$ is in the κ -neighbourhood of V . Since $h^+([\alpha(t_3), \alpha(+\infty[) < +\infty$, we have that $\lim_{t \rightarrow +\infty} h(\alpha(t)) = -\infty$, hence there exists $t_4 \geq t_3$ such that $h(\alpha(t_4)) \leq h(\alpha(t_1)) - 7C_0$. Then Lemma 5.2.2 tells us that α is first $17C_0$ -coarsely increasing, which contradicts what we assumed. \square

We have classified the possible shapes of geodesic rays. Since geodesic lines are constructed from two geodesic rays glued together, we will be able to classify their shapes too.

Definition 5.3.5. *Let N be an admissible norm and let $\alpha = (\alpha_X, \alpha_Y) : \mathbb{R} \rightarrow X \rtimes Y$ be a path of $(X \rtimes Y, d_{\rtimes})$. Let $\kappa \geq 0$.*

1. α is called *X-type* at scale κ if and only if:

- (a) α_X is in a κ -neighbourhood of a geodesic of X
- (b) α_Y is in a κ -neighbourhood of a vertical geodesic of Y .

2. α is called *Y-type* at scale κ if and only if:

- (a) α_Y is in a κ -neighbourhood of a geodesic of Y
- (b) α_X is in a κ -neighbourhood of a vertical geodesic of X .

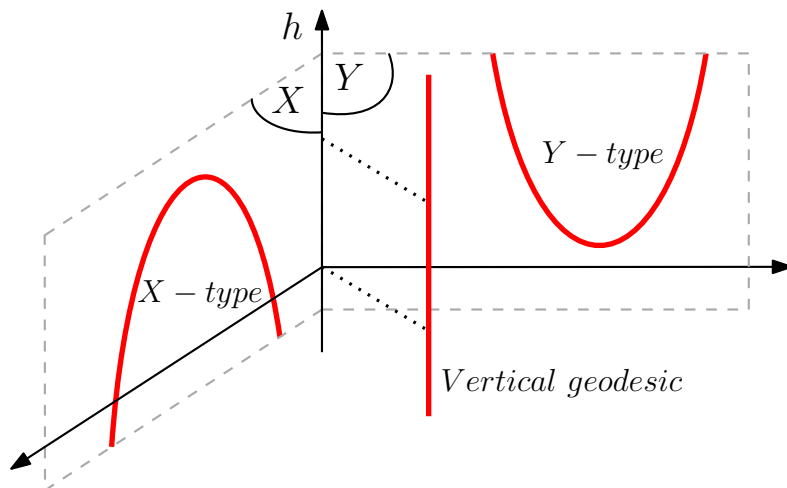
Figure 5.3: Different type of geodesics in $X \times Y$.

The X -type paths follow geodesics of X , meaning that they are close to a geodesic in a copy of X inside $X \times Y$. The Y -type paths follow geodesics of Y .

Remark 5.3.6. In a horospherical product, being close to a vertical geodesic is equivalent to be both X -type and Y -type.

Theorem 5.3.7. Let N be an admissible norm. There exists $\kappa \geq 0$ depending only on δ and N such that for any $\alpha : \mathbb{R} \rightarrow X \times Y$ geodesic of $(X \times Y, d_{\times})$ at least one of the two following statements holds.

1. α is a X -type geodesic at scale κ of $(X \times Y, d_{\times})$
2. α is a Y -type geodesic at scale κ of $(X \times Y, d_{\times})$

Proof. It follows from Lemma 5.3.4 that α changes its coarse monotonicity at most once. Otherwise there would exist a geodesic ray included in α that changes at least two times of coarse monotonicity. We cut α in two coarsely monotone geodesic rays $\alpha_1 : [0, +\infty[\rightarrow X \times Y$ and $\alpha_2 : [0, +\infty[\rightarrow X \times Y$ such that up to a parametrisation $\alpha_1(0) = \alpha_2(0)$ and $\alpha_1 \cup \alpha_2 = \alpha$. By Lemma 5.3.3 there exists κ_1 and κ_2 depending only on δ such that α_1 is in the κ_1 -neighbourhood of a vertical geodesic ray $V_1 = (V_{1,X}, V_{1,Y}) : [0, +\infty[\rightarrow X \times Y$ and such that α_2 is in the κ_2 -neighbourhood of a vertical geodesic ray $V_2 = (V_{2,X}, V_{2,Y}) : [0, +\infty[\rightarrow X \times Y$. This lemma also gives us $d_{\times}(\alpha_1(0), V_1(0)) \leq \kappa_1$ and $d_{\times}(\alpha_2(0), V_2(0)) \leq \kappa_2$.

Assume that $\lim_{t \rightarrow +\infty} h(V_{1,X}(t)) = \lim_{t \rightarrow +\infty} h(V_{2,X}(t)) = +\infty$, then they are both vertical rays hence are close to a common vertical geodesic ray. Furthermore $\lim_{t \rightarrow +\infty} h(V_{1,Y}(t)) = \lim_{t \rightarrow +\infty} h(V_{2,Y}(t)) = -\infty$ in that case. Let W_Y be the non continuous path of Y defined as follows.

$$W_Y(t) = \begin{cases} V_{1,Y}(-t) & \forall t \in]-\infty; 0] \\ V_{2,Y}(t) & \forall t \in]0; +\infty[\end{cases}$$

We now prove that $W_Y : \mathbb{R} \rightarrow Y$ is a quasigeodesic of Y . Let t_1 and t_2 be two real numbers. Since $V_{1,Y}$ and $V_{2,Y}$ are geodesics, $d_Y(W_Y(t_1), W_Y(t_2)) = |t_1 - t_2|$ if t_1 and t_2 are both non positive or both positive. Thereby we can assume without loss of generality that t_1 is non positive and that t_2 is positive. We also assume without loss of generality that $|t_1| \geq |t_2|$. The quasi-isometric upper bound is given by:

$$\begin{aligned} d_Y(W_Y(t_1), W_Y(t_2)) &= d_Y(V_{1,Y}(-t_1), V_{2,Y}(t_2)) \\ &\leq d_Y(V_{1,Y}(-t_1), V_{1,Y}(0)) + d_Y(V_{1,Y}(0), V_{2,Y}(0)) + d_Y(V_{2,Y}(0), V_{2,Y}(t_2)) \\ &\leq |t_1| + \kappa_1 + \kappa_2 + |t_2| \\ &\leq |t_1 - t_2| + \kappa_1 + \kappa_2, \text{ since } t_1 \text{ and } t_2 \text{ have different signs.} \end{aligned}$$

It remains to prove the lower bound of the quasi-geodesic definition on W_Y .

$$\begin{aligned} d_Y(W_Y(t_1), W_Y(t_2)) &= d_Y(V_{1,Y}(-t_1), V_{2,Y}(t_2)) \\ &\geq \frac{1}{2C_N} d_{\bowtie}(V_1(-t_1), V_2(t_2)) - d_X(V_{1,X}(-t_1), V_{2,X}(t_2)) \\ &\geq \frac{1}{2C_N} d_{\bowtie}(\alpha(t_1), \alpha(t_2)) - \frac{\kappa_1 + \kappa_2}{C_N} - d_X(V_{1,X}(-t_1), V_{2,X}(t_2)). \end{aligned} \quad (5.11)$$

The Busemann assumption on X provides us with:

$$d_X(V_{1,X}(-t_1), V_{2,X}(-t_1)) \leq d_X(V_{1,X}(0), V_{2,X}(0)) \leq \kappa_1 + \kappa_2.$$

Since α is a geodesic and by using the triangle inequality on (5.11) we have:

$$\begin{aligned} d_Y(W_Y(t_1), W_Y(t_2)) &\geq \frac{|t_1 - t_2|}{2C_N} - d_X(V_{1,X}(-t_1), V_{2,X}(-t_1)) - d_X(V_{2,X}(-t_1), V_{2,X}(t_2)) - \frac{\kappa_1 + \kappa_2}{C_N} \\ &\geq \frac{|t_1 - t_2|}{2C_N} - \Delta h(V_{2,Y}(-t_1), V_{2,Y}(t_2)) - \left(\frac{1}{C_N} + 1\right)(\kappa_1 + \kappa_2). \end{aligned}$$

Assume that $\Delta h(V_{2,Y}(-t_1), V_{2,Y}(t_2)) \leq \frac{|t_1 - t_2|}{4C_N}$, then:

$$d_Y(W_Y(t_1), W_Y(t_2)) \geq \frac{|t_1 - t_2|}{4C_N} - \left(\frac{1}{C_N} + 1\right)(\kappa_1 + \kappa_2).$$

Hence W_Y is a $\left(\frac{1}{4C_N}, \left(\frac{1}{C_N} + 1\right)(\kappa_1 + \kappa_2)\right)$ quasi-geodesic, which was the remaining case. Since κ_1 and κ_2 depend only on δ and N , there exists a constant κ' depending only on δ and N such that $V_{1,Y} \cup V_{2,Y}$ is in the κ' -neighbourhood of a geodesic of Y . The geodesic α is a Y -type geodesic in this case.

Assume $\lim_{t \rightarrow +\infty} h(V_{1,X}(t)) = \lim_{t \rightarrow +\infty} h(V_{2,X}(t)) = -\infty$, we prove similarly that α is a X -type geodesic. \square

If a geodesic is both X -type at scale κ and Y -type at scale κ , then it is in a κ -neighbourhood of a vertical geodesic of $X \bowtie Y$.

5.4 Visual boundary of $X \bowtie Y$

We will now look at the visual boundary of our horospherical products. This notion is described for the Sol geometry in the work of Troyanov [26, Troyanov] through the objects called geodesic horizons. We extend one of the definitions presented in page 4 of [26, Troyanov] for horospherical products.

Definition 5.4.1. *Two geodesics of a metric space X are called asymptotically equivalent if they are at finite Hausdorff distance from each other.*

Definition 5.4.2. *Let X be a metric space and let o be a base point of X . The visual boundary of X is the set of asymptotic equivalence classes of geodesic rays $\alpha : \mathbb{R}^+ \rightarrow X$ such that $\alpha(0) = o$, it is denoted by $\partial_o X$.*

We will use a result of [22, Papadopoulos] to describe the visual boundary of horospherical products.

Property 5.4.3 (Property 10.1.7 p.234 of [22]). *Let X be a proper Busemann space, let q be a point in X and let $r : [0, +\infty[\rightarrow X$ be a geodesic ray. Then, there exists a unique geodesic ray r' starting at q that is asymptotic to r .*

Theorem 5.4.4. *Let N be an admissible norm. We fix base points and directions $(w_X, a_X) \in X \times \partial X$, $(w_Y, a_Y) \in Y \times \partial Y$. Let $X \bowtie Y$ be the horospherical product with respect to (w_X, a_X) and (w_Y, a_Y) . Then the visual boundary of $(X \bowtie Y, d_{\bowtie})$ with respect to a base point $o = (o_X, o_Y)$ is given by:*

$$\begin{aligned} \partial_o(X \bowtie Y) &= \left((\partial X \setminus \{a_X\}) \times \{a_Y\} \right) \cup \left(\{a_X\} \times (\partial Y \setminus \{a_Y\}) \right) \\ &= \left((\partial X \times \{a_Y\}) \cup (\{a_X\} \times \partial Y) \right) \setminus \{(a_X, a_Y)\} \end{aligned}$$

The fact that (a_X, a_Y) is not allowed as a direction in $X \rtimes Y$ is understandable since both heights in X and Y would tend to $+\infty$, which is impossible by the definition of $X \rtimes Y$.

Proof. Let α be a geodesic ray. Lemma 5.3.4 implies that there exists $t_0 \in \mathbb{R}$ such that α is coarsely monotone on $[t_0, +\infty[$. Then Lemma 5.3.3 tells us that $\alpha([t_0, +\infty[)$ is at finite Hausdorff distance from a vertical geodesic ray $V = (V_X, V_Y)$, hence α is also at finite Hausdorff distance from V .

Since X is Busemann and proper, Property 5.4.3 ensure us there exists V'_X a vertical geodesic ray such that V_X and V'_X are at finite Hausdorff distance with $V'_X(0) = o_X$. Similarly, there exists V'_Y a vertical geodesic ray of Y with $V'_Y(0) = o_Y$ such that V_Y and V'_Y are at finite Hausdorff distance.

Furthermore, there is at least one vertical geodesic ray $V' = (V'_Y, V'_X)$ in every asymptotic equivalence class of geodesic rays, hence $\partial_o X \rtimes Y$ is the set of asymptotic equivalence classes of vertical geodesic rays starting at o . Therefore, an asymptotic equivalence class can be identified by the couple of directions of a vertical geodesic ray. Then $\partial_o X \rtimes Y$ can be identified to:

$$\left((\partial X \setminus \{a_X\}) \times \{a_Y\} \right) \cup \left(\{a_X\} \times (\partial Y \setminus \{a_Y\}) \right).$$

the union between downward directions and upward directions, which proves the theorem. \square

Example 5.4.5. *In the case of Sol, X and Y are hyperbolic planes \mathbb{H}_2 , hence their boundaries are $\partial X = \partial \mathbb{H}_2 = S^1$ and $\partial Y = S^1$. Then $\partial_o \text{Sol}$ can be identified to the following set:*

$$(S^1 \setminus \{a_X\}) \times \{a_Y\} \cup \{a_X\} \times (S^1 \setminus \{a_Y\}). \quad (5.12)$$

It can be seen as two lines at infinity, one upward $\{a_X\} \times (S^1 \setminus \{a_Y\})$ and the other one downward $(S^1 \setminus \{a_X\}) \times \{a_Y\}$.

It is similar to Proposition 6.4 of [26, Troyanov].

Part II

Coarse differentiation and quasi-isometries product maps

Chapter 6

Notations on horospherical products

In this chapter we recall some material about horospherical products.

In order to lighten the notations, we will not fully describe the multiplicative and additive constants involved in inequalities. We will use the following notations instead.

Notation 6.0.1. Let $A, B \in \mathbb{R}$ and e a parameter (set, real numbers, ...). Let us denote:

1. $A \leq_e B$ if and only if there exists a constant $M(e)$ depending only on e such that $A \leq M(e)B$
2. $A \asymp_e B$ if and only if $B \leq_e A \leq_e B$

If the constant M is a specific integer such as 2, we will simply denote $A \leq B$, and similarly $A \geq B$, $A \asymp B$. The notation \leq_e might also appear for parameters in several results of this paper. In this context it means that there exists a constant depending only on e such that the implied result holds.

A metric space is called geodesically complete if all its geodesic segments can be extended into geodesic lines. Hence, in a Gromov hyperbolic and Busemann space, with respects to $a \in \partial X$, any point is included in a vertical geodesic line (not necessarily unique).

We recall Lemma [3.2.3](#) of Part I.

Lemma 6.0.2.

Let X be a proper, δ -hyperbolic, Busemann space. Let V_1 and V_2 be two vertical geodesics of H . Let $t_1, t_2 \in \mathbb{R}$ and let us denote $D := \frac{1}{2}d_r(V_1(t_1), V_2(t_2))$. Then for all $t \in [0, D]$

$$|d_r(V_1(t_1 + D - t), V_2(t_2 + D - t)) - 2t| \leq 288\delta \quad (6.1)$$

Corollary 6.0.3. Let V_1, V_2 be two vertical geodesics of X . Then there exists a height $h_{\text{div}}(V_1, V_2) \in \mathbb{R}$ from which V_1 and V_2 diverge from each other:

1. $\forall t \geq h_{\text{div}}(V_1, V_2), \quad d(V_1(t), V_2(t)) \leq_\delta 1$
2. $\forall t \leq h_{\text{div}}(V_1, V_2), \quad |d(V_1(t), V_2(t)) - 2t| \leq_\delta 1$

This corollary is illustrated in Figure [6.1](#)

We list here some notations we will use in later sections.

Notation 6.0.4. Let X be a proper, geodesically complete, δ -hyperbolic, Busemann space.

1. Let us denote the r -neighbourhood of U for all $U \subset X$ and for all $r \geq 0$ by

$$\mathcal{N}_r(U) := \{x \in X \mid d(x, U) \leq r\} \quad (6.2)$$

2. For all $x \in X$ let us denote by V_x the unique vertical geodesic ray such that $V_x(0) = x$.

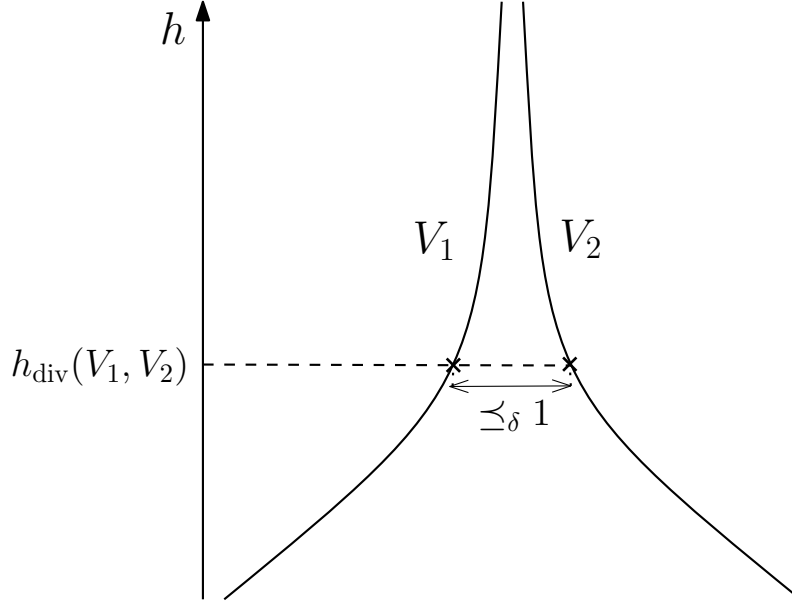
Figure 6.1: Figure of Lemma 6.0.3.

3. For a subset $A \subset X$, let us denote

$$h^-(A) := \inf_{x \in A} (h(x)) \quad ; \quad h^+(A) := \sup_{x \in A} (h(x)). \quad (6.3)$$

4. For a subset $A \subset X$ and a height $z \in \mathbb{R}$, we denote the slice of A at the height z by $A_z := A \cap h^{-1}(z)$. Therefore the horospheres of X are denoted by X_z for $z \in \mathbb{R}$.

5. Given a point $p \in X$ and a radius $r \in \mathbb{R}^+$, let us denote the ball of radius r included in the horosphere $X_{h(p)}$ by $D_r(p) := \{x \in X \mid h(x) = h(p) \text{ and } d(x, p) \leq r\} = B(p, r) \cap X_{h(p)}$.

6. $\forall z \in \mathbb{R}, \forall U \subset X_z, \forall r > 0$, the r -interior of U in X_z is defined by

$$\text{Int}_r(U) := \{p \in U \mid d(p, q) \geq r, \forall q \in X_z \setminus U\}.$$

Vertical geodesics of X can be understood as being normal to horospheres of X .

Definition 6.0.5 (Projection on horospheres).

Let X Gromov hyperbolic, Busemann, proper, geodesically complete metric space. Then for all $A \subset X$ and all $z \leq h^-(A)$

$$\pi_z(A) := \{x \in X_z \mid V_x \cap A \neq \emptyset\} \quad (6.4)$$

The definition of this projection along the vertical flow is illustrated in Figure 6.2. The following Lemma shows that the projection of a disk on a horosphere is almost a disk, It will be used in further Sections.

Lemma 6.0.6. Let X be a Gromov hyperbolic, Busemann, proper, geodesically complete metric space. Let $z_0 \in \mathbb{R}$ and $p \in X_{z_0}$. Then for $M \geq 288\delta$ we have that for all $z \leq z_0$ and for all $p_z \in \pi_z(\{p\})$

$$D_{2(z_0-z)-M}(p_z) \subset \pi_z(D_M(p)) \subset D_{2(z_0-z)+M}(p_z).$$

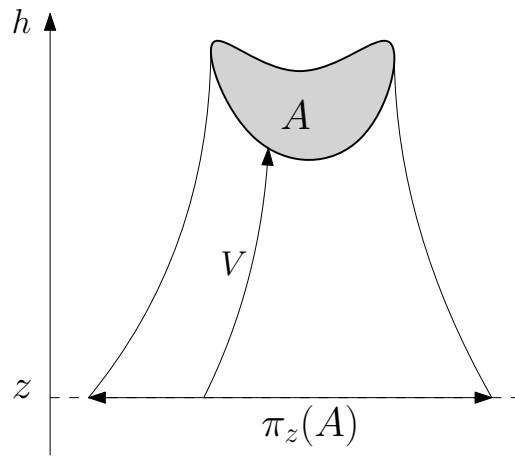
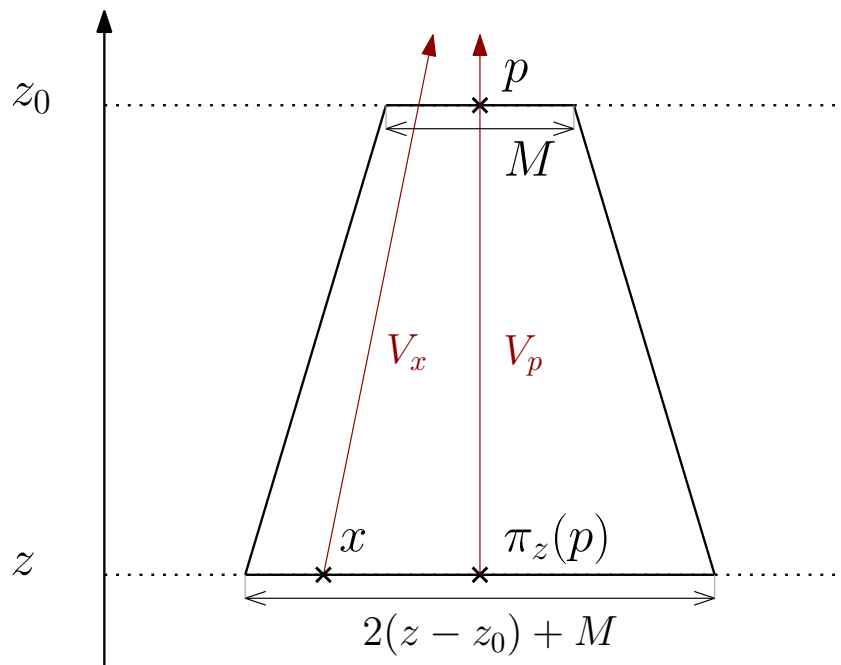
Figure 6.2: Projection of A on X_z .Figure 6.3: Proof of Lemma 6.0.6

Proof. This Lemma is a corollary of Lemma 6.0.2 and is illustrated in Figure 6.3. Let $M = 288\delta$ be the constant involved in Lemma 6.0.2

Let us prove the first inclusion. Let $x \in D_{2(z_0-z)-M}(p_z)$, then $d(x, p_z) \leq 2(z_0 - z) - M$. Let us denote V_x a vertical geodesic containing x and V_p a vertical geodesic containing p and p_z . We apply Lemma 6.0.2 with $t_1 = t_2 = z$, $V_1 = V_x$ and $V_2 = V_p$, then $D = \frac{d(x, p_z)}{2}$. Moreover

$$z + D = z + \frac{d(x, p_z)}{2} \leq z + (z_0 - z) - \frac{M}{2} \leq z_0.$$

Therefore, by the Busemann convexity of X , the distance between vertical geodesic ray is convex and bounded, hence decreasing. Therefore

$$\begin{aligned} d(V_x(z_0), p) &= d(V_x(z_0), V_p(z_0)) \leq d(V_x(z + D), V_p(z + D)) \\ &\leq M, \text{ by Lemma 6.0.2 used with } t = 0, \end{aligned}$$

which means that $x \in \pi_z(D_M(p))$.

Let us now prove the second inclusion, which is

$$\pi_z(D_M(p)) \subset D_{2(z_0-z)+M}(p_z). \quad (6.5)$$

Let $x \in \pi_z(D_M(p))$, then $d(V_x(z_0), V_p(z_0)) \leq M$. Therefore by the triangle inequality

$$\begin{aligned} d(x, p_z) &= d(V_x(z), V_p(z)) \leq d(V_x(z), V_x(z_0)) + d(V_x(z_0), V_p(z_0)) + d(V_p(z_0), V_p(z)) \\ &\leq (z_0 - z) + M + (z_0 - z) = 2(z_0 - z) + M \end{aligned}$$

Hence $x \in D_{2(z_0-z)+M}(p_z)$. \square

We recall that given a proper, δ -hyperbolic space X with distinguished $a \in \partial X$ and $w \in X$, we defined the height function on X in Definition 2.2.1 from the Busemann functions with respect to $a \in \partial X$ and $w \in X$.

Definition 6.0.7 (Horospherical product). *Let X and Y be two δ -hyperbolic spaces. We fix the base points $w^X \in X$, $w^Y \in Y$ and the points in the boundaries $a^X \in \partial X$, $a^Y \in \partial Y$. We consider their height functions h^X and h^Y respectively on X and Y . We define the horospherical product of X and Y by*

$$X \bowtie Y := \{ (a^X, a^Y) \in X \times Y \mid h^X(a^X) + h^Y(a^Y) = 0 \}.$$

This construction, illustrated in Figure 6.4 can also be seen as the union of the direct products between opposite horospheres in X and Y

$$X \bowtie Y = \bigsqcup_{z \in \mathbb{R}} X_z \times Y_{-z}.$$

From now on, with a slight abuse, we omit the reference to the base points and points on the boundaries in the construction of the horospherical product. Notations 6.0.4 can be extended to horospherical products.

Notation 6.0.8. *Let X and Y be two proper, hyperbolic, geodesically complete, Busemann spaces. Then:*

1. *We denote the r -neighbourhood of U , for all $U \subset X \bowtie Y$ and for all $r \geq 0$, by*

$$\mathcal{N}_r(U) := \{ p \in X \bowtie Y \mid d_{\bowtie}(p, U) \leq r \}. \quad (6.6)$$

2. *The difference of height between two points $a, b \in X \bowtie Y$ is still denoted by $\Delta h(a, b) := |h(a) - h(b)|$.*
3. *We still denote, for all $z \in \mathbb{R}$ and $A \subset X \bowtie Y$, by $A_z := A \cap h^{-1}(z)$ the "slice" of A at the height z .*

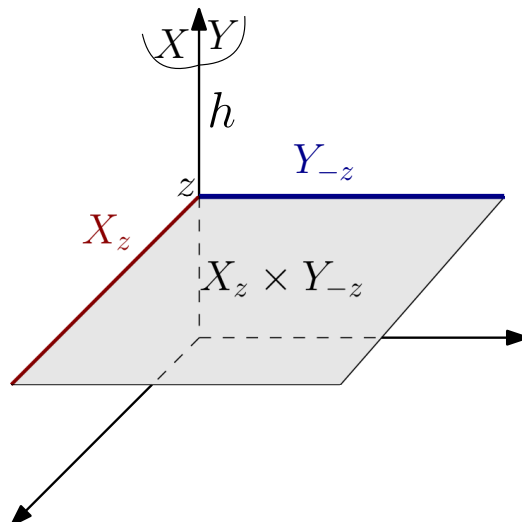
Figure 6.4: Horospherical product $X \rtimes Y$.

4. We still denote, for all $r \geq 0$ and $p \in X \rtimes Y$, by

$$D_r(p) := \{x \in X \mid h(p) = h(x) \text{ and } d_{\rtimes}(p, x) \leq r\} = B(p, r) \cap (X \rtimes Y)_{h(p)}$$

the ball of radius r in the height level set containing p .

We also provide two more definitions that will be used in future sections. First a projection on level-sets of the height function.

Definition 6.0.9. Let $z_0, z \in \mathbb{R}$ and let $U \subset (X \rtimes Y)_{z_0}$. Then we define the projection of U on $(X \rtimes Y)_z$ by

$$\pi_z^{\rtimes}(U) := \{p \in (X \rtimes Y)_z \mid \exists V \text{ a vertical geodesic such that } p \in V \text{ and } V \cap U \neq \emptyset\}$$

Then we define X -horospheres and Y -horospheres as horospheres of hyperbolic spaces embedded in $X \rtimes Y$, illustrated in Figure 6.5.

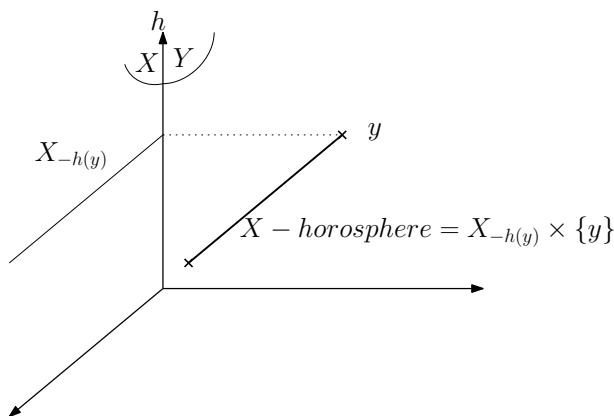
Figure 6.5: X -Horosphere in $X \rtimes Y$.

Definition 6.0.10. The set $H \subset X \rtimes Y$ is called

1. an X -horosphere if there exists $y \in Y$ such that $H = X \rtimes \{y\} = X_{-h(y)} \times \{y\}$

2. a Y -horosphere if there exists $x \in X$ such that $H = \{x\} \rtimes Y = \{x\} \times Y_{-h(x)}$

From now on, we will work in a horospherical product $X \rtimes Y$ of two proper, geodesically complete, δ -hyperbolic and Busemann spaces.

Chapter 7

Metric aspects and metric tools in horospherical products

Through out this section we fix two constants $k \geq 1$ and $c \geq 0$. We recall the notions of quasi-isometry and quasi-geodesic.

Definition 7.0.1. ((k, c) -quasi-isometry)

Let (E, d_E) and (F, d_F) be two metric spaces. A map $\Phi : E \rightarrow F$ is called a (k, c) -quasi-isometry if and only if:

1. For all $x, x' \in E$, $k^{-1}d_E(x, x') - c \leq d_F(\Phi(x), \Phi(x')) \leq kd_E(x, x') + c$.
2. For all $y \in F$, there exists $x \in E$ such that $d(\Phi(x), y) \leq c$.

A map verifying 1. is called a quasi-isometric embedding of E .

Definition 7.0.2. ((k, c) -quasigeodesic)

Let E be a metric space. A (k, c) -quasigeodesic segment, respectively ray, line, of E is a (k, c) -quasi-isometric embedding of a segment, respectively $[0; +\infty[$, \mathbb{R} , into E .

In Lemma 2.1 of [17], Gouëzel and Shchur prove that any (k, c) -quasigeodesic segment is included in the $2c$ -neighbourhood of a continuous $(k, 4c)$ -quasigeodesic segment sharing the same endpoints. Therefore, without loss of generality, we may consider that all quasi-geodesic segments are continuous.

This section gathers several geometric results on horospherical products, including the generalisation in our context of Lemmas 4.6, 3.1 and the coarse differentiation previously obtained by Eskin, Fisher and Whyte in [10]. Proposition 7.1.4, Corollary 7.1.5 and Proposition 7.3.2 of this section will be especially useful in the following proofs.

At first, a reader who is more interested in the rigidity result on horospherical product can take these propositions for granted and jump to the next sections.

When $A \simeq_e B$, and $e = (X \rtimes Y, d)$ is a horospherical product, we shall write $A \simeq_{\rtimes} B$ as a short-cut, and similarly \leq_{\rtimes} , \geq_{\rtimes} and $M(\rtimes)$ for a constant depending only on the metric horospherical product $(X \rtimes Y, d_{\rtimes})$.

7.1 ε -monotonicity

We introduce ε -monotone quasigeodesics. They happen to be close to vertical geodesics.

Definition 7.1.1. (ε -monotone quasigeodesic)

Let $\varepsilon \geq 0$ and let $\alpha : [0, R] \rightarrow X \rtimes Y$ be a quasigeodesic segment. Then α is called ε -monotone if and only if

$$\forall t_1, t_2 \in [0, R], \left(h(\alpha(t_1)) = h(\alpha(t_2)) \right) \Rightarrow \left(|t_1 - t_2| \leq \varepsilon R \right) \quad (7.1)$$

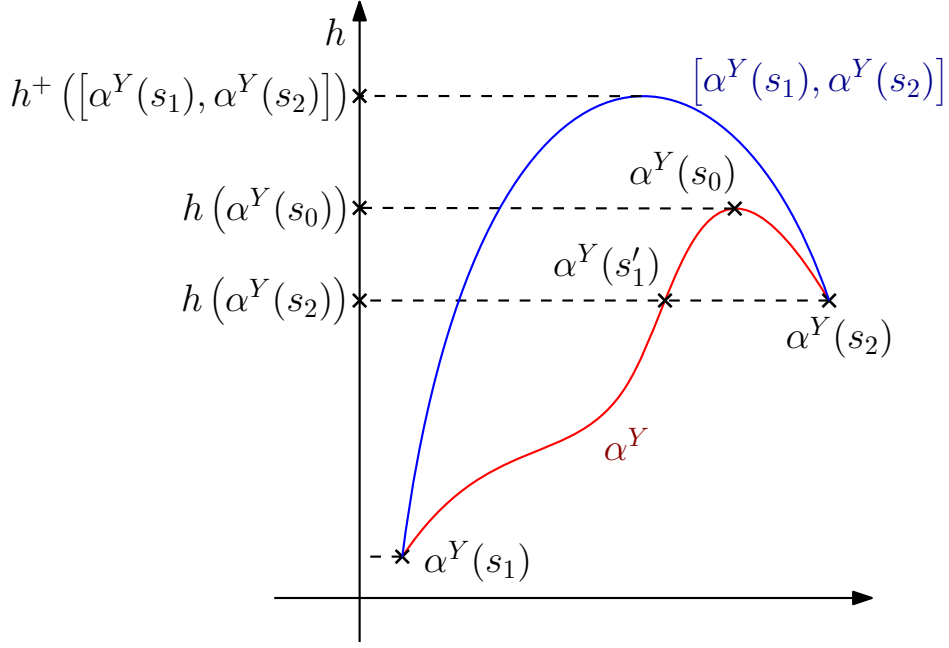

Figure 7.1: Proof of Theorem 7.1.2

Since α is assumed to be continuous, a 0-monotone quasigeodesic has monotone height, $h \circ \alpha$ is either decreasing or increasing. We first show that in $X \bowtie Y$, the projections on X and Y of an ε -monotone quasigeodesic are also quasigeodesics.

Theorem 7.1.2. *Let $\varepsilon > 0$, $R > \frac{1}{\varepsilon}$, and $\alpha = (\alpha^X, \alpha^Y) : [0, R] \rightarrow X \bowtie Y$ be an ε -monotone (k, c) -quasigeodesic segment. Then there exists a constant $M(\bowtie, k, c)$ (depending only on \bowtie , k and c) such that α^X and α^Y are $(4k, M\varepsilon R)$ -quasigeodesics.*

A portion of the proof of Theorem 7.1.2 is illustrated in figure 7.1.

Proof. We know that $\forall p_1 = (p_1^X, p_1^Y), p_2 = (p_2^X, p_2^Y) \in X \bowtie Y$ we have (this is the admissible assumption we made on the norm underneath the distance d_\bowtie)

$$d_\bowtie(p_1, p_2) \geq \frac{d_X(p_1^X, p_2^X) + d_Y(p_1^Y, p_2^Y)}{2} \quad (7.2)$$

Therefore we have that α^X satisfies the upper-bound assumption of quasigeodesics

$$\forall s_1, s_2 \in [0, R], d_X(\alpha^X(s_1), \alpha^X(s_2)) \leq 2d_\bowtie(\alpha(s_1), \alpha(s_2)) \leq 2k|s_1 - s_2| + 2c$$

We want to find an appropriate $c' \geq c$ such that α^X satisfies the lower-bound condition of a $(4k, c')$ -quasigeodesic. Let $c' \geq c$ and let us assume that α^X does not satisfy the lower-bound condition of a $(4k, c')$ -quasigeodesic, we will show that this provides us with an upper-bound on c' . Indeed, consider $s_1, s_2 \in [0, R]$ such that

$$0 \leq d_X(\alpha^X(s_1), \alpha^X(s_2)) \leq \frac{1}{4k}|s_1 - s_2| - c' \quad (7.3)$$

therefore by the Lipschitz property of h

$$\begin{aligned} \Delta h(\alpha^X(s_1), \alpha^X(s_2)) &\leq d_X(\alpha^X(s_1), \alpha^X(s_2)) \leq \frac{1}{4k}|s_1 - s_2| - c'. \\ &\leq \frac{1}{4}d_\bowtie(\alpha(s_1), \alpha(s_2)) + \frac{c}{4} - c', \quad \text{since } \alpha \text{ is a } (k, c)\text{-quasigeodesic.} \end{aligned} \quad (7.4)$$

Corollary 4.3.4 of the first part of this manuscript gives us the existence a constant $M(\varkappa)$ depending only on X, Y and the underlying norm of d_\varkappa such that

$$\begin{aligned}
& d_Y(\alpha^Y(s_1), \alpha^Y(s_2)) \tag{7.5} \\
& \geq d_\varkappa(\alpha(s_1), \alpha(s_2)) - d_X(\alpha^X(s_1), \alpha^X(s_2)) - \Delta h(\alpha(s_1), \alpha(s_2)) - M \\
& \geq d_\varkappa(\alpha(s_1), \alpha(s_2)) - 2d_X(\alpha^X(s_1), \alpha^X(s_2)) - M, \quad \text{by Lemma 4.1.6,} \\
& \geq d_\varkappa(\alpha(s_1), \alpha(s_2)) - \frac{1}{2k}|s_1 - s_2| + 2c' - M, \quad \text{by assumption (7.3),} \\
& \geq d_\varkappa(\alpha(s_1), \alpha(s_2)) - \frac{1}{2}d_\varkappa(\alpha(s_1), \alpha(s_2)) - \frac{c}{2k} + 2c' - M, \quad \text{since } \alpha \text{ is a } (k, c)\text{-quasigeodesic,} \\
& \geq \frac{1}{2}d_\varkappa(\alpha(s_1), \alpha(s_2)) - \frac{c}{2} + 2c' - M, \quad \text{since } k \geq 1. \tag{7.6}
\end{aligned}$$

Without loss of generality, we may assume that $\max(h(\alpha^Y(s_1)), h(\alpha^Y(s_2))) = h(\alpha^Y(s_2))$. Applying Lemma 3.1.2 on the geodesic $[\alpha^Y(s_1), \alpha^Y(s_2)]$ of Y gives us

$$h^+([\alpha^Y(s_1), \alpha^Y(s_2)]) \geq h(\alpha^Y(s_2)) + \frac{1}{2}(d_Y(\alpha^Y(s_1), \alpha^Y(s_2)) - \Delta h(\alpha^Y(s_1), \alpha^Y(s_2))) - M(\varkappa)$$

However α^Y is a continuous path between $\alpha^Y(s_1)$ and $\alpha^Y(s_2)$, then by Proposition 3.2.1 there exists $s_0 \in [s_1, s_2]$ such that

$$\begin{aligned}
h(\alpha^Y(s_0)) & \geq h(\alpha^Y(s_2)) + \frac{1}{2}(d_Y(\alpha^Y(s_1), \alpha^Y(s_2)) - \Delta h(\alpha^Y(s_1), \alpha^Y(s_2))) \\
& \quad - \delta \log_2(d_Y(\alpha^Y(s_1), \alpha^Y(s_2))) - M(\varkappa)
\end{aligned}$$

Therefore by inequalities (7.4) and (7.6)

$$\begin{aligned}
h(\alpha^Y(s_0)) & \geq h(\alpha^Y(s_2)) + \frac{1}{4}d_\varkappa(\alpha(s_1), \alpha(s_2)) - \frac{1}{8}d_\varkappa(\alpha(s_1), \alpha(s_2)) - \frac{c}{4} + c' - \frac{c}{8} + \frac{1}{2}c' \\
& \quad - \delta \log_2(d_Y(\alpha^Y(s_1), \alpha^Y(s_2))) - \frac{M(\varkappa)}{2} \\
& \geq h(\alpha^Y(s_2)) + \frac{1}{8}d_\varkappa(\alpha(s_1), \alpha(s_2)) - \delta \log_2(d_Y(\alpha^Y(s_1), \alpha^Y(s_2))) + \frac{3}{2}c' - M(\varkappa, c)
\end{aligned}$$

However $2d_\varkappa \geq d_X + d_Y \geq d_Y$, hence

$$h(\alpha^Y(s_0)) \geq h(\alpha^Y(s_2)) + \frac{1}{8}d_\varkappa(\alpha(s_1), \alpha(s_2)) - \delta \log_2(d_\varkappa(\alpha(s_1), \alpha(s_2))) + \frac{3}{2}c' - M(\varkappa, c) \tag{7.7}$$

Furthermore, there exists $r_0 \in \mathbb{R}$ depending only on δ such that $\forall r \geq r_0, \frac{1}{8}r - \delta \log_2(r) > \frac{1}{10}r$ holds. Therefore, one of the two following statements holds:

- (a) $d_\varkappa(\alpha(s_1), \alpha(s_2)) < r_0$
- (b) $\frac{1}{8}d_\varkappa(\alpha(s_1), \alpha(s_2)) - \delta \log_2(d_\varkappa(\alpha(s_1), \alpha(s_2))) \geq \frac{1}{10}d_\varkappa(\alpha(s_1), \alpha(s_2))$

We will deal with the first case (a) at the end of the proof. Let us assume that $d_\varkappa(\alpha(s_1), \alpha(s_2)) \geq r_0$ hence (b), then by inequality (7.7)

$$h(\alpha^Y(s_0)) \geq h(\alpha^Y(s_2)) + \frac{1}{10}d_\varkappa(\alpha(s_1), \alpha(s_2)) + \frac{3}{2}c' - M(\varkappa, c) \tag{7.8}$$

Then either $d_\varkappa(\alpha(s_1), \alpha(s_2)) \leq M(\varkappa, c)$ (up to multiplying by 10 the constant M), or $h(\alpha^Y(s_0)) \geq h(\alpha^Y(s_2))$. In the case $d_\varkappa(\alpha(s_1), \alpha(s_2)) \leq M(\varkappa, c)$, then $|s_1 - s_2| \leq_{k,c,\varkappa} 1$ since α is a quasigeodesic, and therefore $c' \leq_{k,c,\varkappa} 1$ following assumption (7.3), hence α^X is a quasigeodesic segment. In the other

case we have $h(\alpha^Y(s_0)) \geq h(\alpha^Y(s_2))$, therefore there exists $s'_1 \in [s_1, s_0]$ such that $h(\alpha^Y(s'_1)) = h(\alpha^Y(s_2))$, since α is continuous. Hence

$$\begin{aligned}
d_{\mathfrak{M}}(\alpha(s'_1), \alpha(s_2)) &\geq \frac{1}{k}|s'_1 - s_2| - c \geq \frac{1}{k}(|s'_1 - s_0| + |s_0 - s_2|) - M(c), \quad \text{since } \alpha \text{ is a quasigeodesic,} \\
&\geq \frac{1}{k^2} \left(d_{\mathfrak{M}}(\alpha(s'_1), \alpha(s_0)) + d_{\mathfrak{M}}(\alpha(s_0), \alpha(s_2)) \right) - M(k, c), \quad \text{since } \alpha \text{ is a quasigeodesic,} \\
&\geq \frac{1}{k^2} \left(\Delta h(\alpha(s'_1), \alpha(s_0)) + \Delta h(\alpha(s_0), \alpha(s_2)) \right) - M(k, c), \quad \text{by Lemma 4.1.6,} \\
&\geq \frac{2}{k^2} \Delta h(\alpha(s_0), \alpha(s_2)) - M(k, c), \quad \text{since } h(\alpha(s'_1)) = h(\alpha(s_2)), \\
&\geq \frac{1}{5k^2} d_{\mathfrak{M}}(\alpha(s_1), \alpha(s_2)) + \frac{3}{k^2} c' - M(k, c, \mathfrak{M}), \quad \text{by (7.8).} \tag{7.9}
\end{aligned}$$

Moreover assumption (7.3) implies $|s_1 - s_2| \geq 4kc'$. Then

$$d_{\mathfrak{M}}(\alpha(s_1), \alpha(s_2)) \geq \frac{1}{k}|s_1 - s_2| - c \geq 4c' - c$$

Combined with inequality (7.9) it gives us

$$d_{\mathfrak{M}}(\alpha(s'_1), \alpha(s_2)) \geq \frac{19}{5k^2} c' - M(k, c, \mathfrak{M})$$

Since α is ε -monotone and because $h(\alpha^Y(s'_1)) = h(\alpha^Y(s_2))$, we have

$$\varepsilon R \geq d_{\mathfrak{M}}(\alpha(s'_1), \alpha(s_2)) \geq \frac{19}{5k^2} c' - M(k, c, \mathfrak{M})$$

Hence

$$c' \leq M(k)\varepsilon R + M(k, c, \mathfrak{M})$$

We proved that if α^X does not verify the lower bound inequality of being a $(4k, c')$ -quasigeodesic then $c' \leq M(k)\varepsilon R + M(k, c, \mathfrak{M})$. Furthermore $\varepsilon R \geq 1$, then there exists $M(k, c, \mathfrak{M})$ such that α^X is a $(4k, M\varepsilon R)$ -quasigeodesic. Similarly we show that α^Y is a $(4k, M\varepsilon R)$ -quasigeodesic segment of Y .

For case (a), let us assume that each couple of times $(s_1, s_2) \in [0, R]^2$ that contradicts the lower-bound hypothesis of a $(4k, M\varepsilon R)$ -quasigeodesic verifies that $d_{\mathfrak{M}}(\alpha(s_1), \alpha(s_2)) < r_0$. Then α is a $(4k, r_0)$ -quasigeodesic, with r_0 depending only on δ . Therefore α is in both cases a $(4k, M\varepsilon R)$ -quasigeodesic, with M depending only on k, c and $X \mathfrak{M} Y$. \square

In the sequel we denote by d_{Hff} the Hausdorff distance induced by $d_{\mathfrak{M}}$. In the the proof of Lemma 7.1.4 we use a quantitative version of the quasigeodesic rigidity in a Gromov hyperbolic space, provided by the main theorem of [17] Gouëzel, Shchur].

Theorem 7.1.3. ([17])

Consider a (k, C) -quasigeodesic segment α in a δ -hyperbolic space X , and γ a geodesic segment between its endpoints. Then the Hausdorff distance $d_{\text{Hff}}(\alpha, \gamma)$ between α and γ satisfies

$$d_{\text{Hff}}(\alpha, \gamma) \leq 92k^2(C + \delta)$$

This quantitative version allows us to have a linear control with respect to C on the Hausdorff distance, which is mandatory in our cases since $C \asymp \varepsilon R$. Combining this rigidity with the fact that projections α^X and α^Y are also ε -monotone provides us with the existence of vertical geodesic segments close to α .

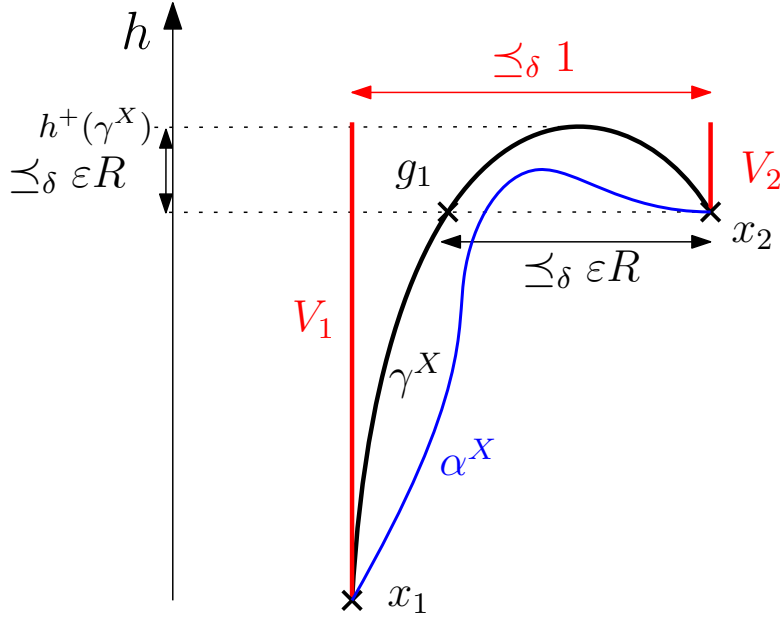
Figure 7.2: Proof of Proposition [7.1.4](#)

Proposition 7.1.4. *Let $\varepsilon > 0$, $R > \frac{1}{\varepsilon}$, and $\alpha : [0, R] \rightarrow X \rtimes Y$ be an ε -monotone (k, c) -quasigeodesic segment. Then there exists a vertical geodesic segment $V : [0, R] \rightarrow X \rtimes Y$ such that*

$$d_{\text{Hff}}(\text{im}(\alpha), \text{im}(V)) \leq_{k,c,\delta} \varepsilon R \quad (7.10)$$

Figure [7.2](#) is an illustration of the proof.

Proof. By Theorem [7.1.2](#), α^X is a $(4k, M\varepsilon R)$ -quasi-geodesic in X which is δ -hyperbolic, hence by Theorem [7.1.3](#) there exists a geodesic γ^X with the same endpoints as α^X such that

$$d_{\text{Hff}}(\text{im}(\alpha^X), \text{im}(\gamma^X)) \leq_{k,c,\delta} \varepsilon R.$$

Let us denote $x_1 := \alpha^X(0)$ and $x_2 := \alpha^X(R)$. The quasigeodesic α^X is also ε -monotone. Furthermore Proposition 2.2 page 19 of [\[5\]](#) Coornaert, Delzant, Papadopoulos] gives us that γ^X , which links x_1 to x_2 , is included in the 24δ -neighbourhood of two vertical geodesic rays V_1 and V_2 such that $V_1(0) = x_1$ and $V_2(0) = x_2$. Let us denote $\tau := h^+(\gamma^X)$, and let us recall that $\forall t_1, t_2 \in \mathbb{R}^+$ and for $i \in \{1, 2\}$ we have $\Delta h(V_i(t_1), V_i(t_2)) = |t_1 - t_2|$. Let us also denote by slight abuse $\gamma^X := \text{im}(\gamma^X)$, $\alpha^X := \text{im}(\alpha^X)$, $V_1 := \text{im}(V_1|_{[0, \tau-h(x_1)]})$ and $V_2 := \text{im}(V_2|_{[0, \tau-h(x_2)]})$. Since $\tau = h^+(\gamma^X) = h^+(V_1) = h^+(V_2)$ we have

$$d_{\text{Hff}}(\gamma^X, V_1 \cup V_2) \leq_{\delta} 1.$$

Hence by the triangle inequality

$$d_{\text{Hff}}(\alpha^X, V_1 \cup V_2) \leq_{k,c,\delta} \varepsilon R. \quad (7.11)$$

Without loss of generality we can assume that $h(x_1) \leq h(x_2)$. Furthermore γ^X is continuous, therefore there exists a point of γ^X close to both vertical geodesics (less than 24δ apart). Furthermore X is Busemann convex, hence the distance between the two vertical geodesics is decreasing. Therefore $d_X(V_1(\tau-h(x_1)), V_2(\tau-h(x_2))) \leq_{\delta} 1$. We will use the ε -monotonicity of α^X to prove that $\tau \approx h(x_2)$. Let us denote by x'_1 a point of α^X such that $h(x'_1) = h(x_2)$ and such that $d_X(x'_1, V_1) \leq_{k,c,\delta} \varepsilon R$. Since

α^X is ε -monotone and a $(4k, M\varepsilon R)$ -quasigeodesic we have that $d_X(x'_1, x_2) \leq_{k,c} \varepsilon R$, hence using the triangle inequality we have

$$\begin{aligned} d_X(V_1(h(x_2) - h(x_1)), x_2) &\leq d_X(V_1(h(x_2) - h(x_1)), x'_1) + d_X(x'_1, x_2) \\ &\leq_{k,c,\delta} \varepsilon R \end{aligned} \quad (7.12)$$

Let $g_1 \in \text{im}(\gamma^X)$ be the closest point to x_1 at height $h(x_2)$. Then we have:

1. $d_X(g_1, V_1(h(x_2) - h(x_1))) \leq_{\delta} 1$
2. $d_X(g_1, x_2) \geq 2(h^+(\gamma^X) - h(x_2))$

We recall that $\tau = h^+(\gamma^X)$, then $d_X(g_1, x_2) \geq 2\tau - 2h(x_2) \geq 0$, hence

$$\begin{aligned} |\tau - h(x_2)| &\leq \frac{1}{2}d_X(g_1, x_2) \leq \frac{1}{2}d_X(g_1, V_1(h(x_2) - h(x_1))) + \frac{1}{2}d_X(V_1(h(x_2) - h(x_1)), x_2) \\ &\leq_{k,c,\delta} \varepsilon R, \quad \text{by definition of } g_1 \text{ and inequality (7.12)}. \end{aligned}$$

Hence $V_2|_{[0, \tau - h(x_2)]}$ is a vertical geodesic segment of length $\leq_{k,c,\delta} \varepsilon R$. Furthermore, $d_X(V_1(\tau - h(x_1)), V_2(\tau - h(x_2))) \leq_{\delta}$. Therefore by the triangle inequality, any point of $V_2|_{[0, \tau - h(x_2)]}$ is (up to a multiplicative constant) εR -close to $V_1(\tau - h(x_1))$. Therefore $d_{\text{Hff}}(V_1 \cup V_2, V_1) \leq_{k,c,\delta} \varepsilon R$. Therefore, by the triangle inequality we can improve inequality (7.11) as follows

$$\begin{aligned} d_{\text{Hff}}(\alpha^X, V_1) &\leq d_{\text{Hff}}(\alpha^X, V_1 \cup V_2) + d_{\text{Hff}}(V_1 \cup V_2, V_1) \\ &\leq_{k,c,\delta} \varepsilon R, \quad \text{by inequality (7.11)}. \end{aligned}$$

We deduce similarly that α^Y is included in the $M\varepsilon R$ -neighbourhood of a vertical geodesic segment V'_2 . Therefore, α is included in the $M\varepsilon R$ -neighbourhood of the vertical geodesic segment (V_1, V'_2) . \square

As a corollary, we show that the height function along an ε -monotone quasigeodesic is a quasi-isometry embedding of a segment into \mathbb{R} .

Corollary 7.1.5. *Let $\alpha : [0, R] \mapsto X \rtimes Y$ be an ε -monotone (k, c) -quasigeodesic segment. Then there exists a constant $M(k, c, \delta)$ such that the height function verifies $\forall t_1, t_2 \in [0, R]$*

$$\frac{1}{k}|t_1 - t_2| - M\varepsilon R \leq \Delta h(\alpha(t_1), \alpha(t_2)) \leq k|t_1 - t_2| + M\varepsilon R \quad (7.13)$$

Proof. Let $t_1, t_2 \in [0, R]$. The quasigeodesic upper-bound inequality is straightforward since h is 1-Lipschitz and α is a (k, c) -quasigeodesic.

$$\Delta h(\alpha(t_1), \alpha(t_2)) \leq d_{\rtimes}(\alpha(t_1), \alpha(t_2)) \leq k|t_1 - t_2| + c.$$

To achieve the lower-bound inequality we use Proposition 7.1.4 hence there exists a vertical geodesic segment $V : [0, R] \rightarrow X \rtimes Y$ and a constant $M(k, c, \delta)$ such that

$$d_{\text{Hff}}(\text{im}(\alpha), \text{im}(V)) \leq M\varepsilon R. \quad (7.14)$$

For $i \in \{1, 2\}$, let $s_i \in [0, R]$ be such that $d_{\rtimes}(\alpha(t_i), V(s_i)) \leq M\varepsilon R$. Then by the triangle inequality

$$\begin{aligned} \Delta h(\alpha(t_1), \alpha(t_2)) &\geq \Delta h(V(s_1), V(s_2)) - 2M\varepsilon R \\ &= |s_1 - s_2| - 2M\varepsilon R, \quad \text{since } V \text{ is vertical.} \end{aligned}$$

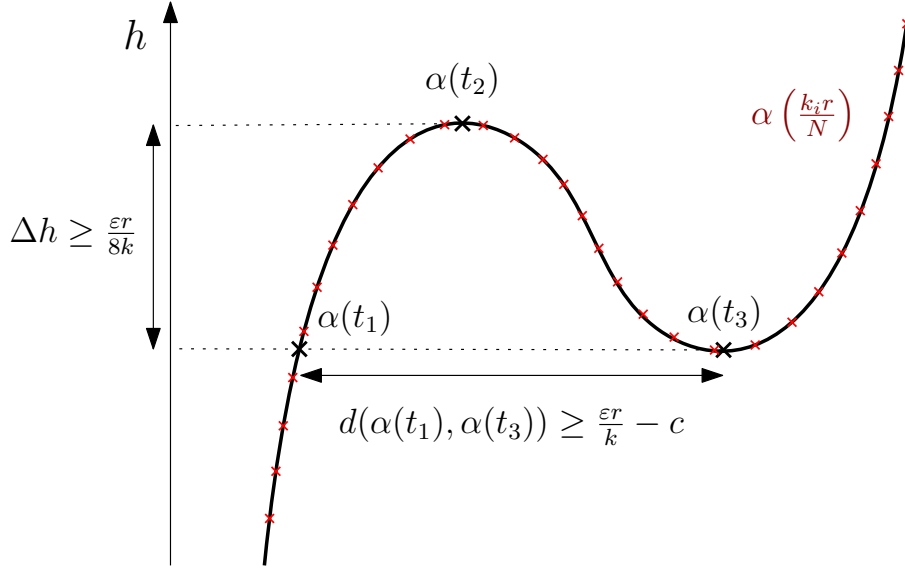

Figure 7.3: Subdivision of a quasi-geodesic.

However we can achieve the lower-bound inequality on $|s_1 - s_2|$

$$\begin{aligned} |s_1 - s_2| &= d_{\mathfrak{M}}((V(s_1), V(s_2))) \geq d_{\mathfrak{M}}(\alpha(t_1), \alpha(t_2)) - 2M\epsilon R, \quad \text{by the triangle inequality,} \\ &\geq \frac{1}{k}|t_1 - t_2| - c - 2M\epsilon R, \quad \text{since } \alpha \text{ is a quasigeodesic.} \end{aligned}$$

Which provides us with

$$\Delta h(\alpha(t_1), \alpha(t_2)) \geq |s_1 - s_2| - 2M\epsilon R \geq \frac{1}{k}|t_1 - t_2| - 5M\epsilon R.$$

□

7.2 Coarse differentiation of a quasigeodesic segment

The coarse differentiation of a quasigeodesic α consists in finding a scale $r > 0$ such that a subdivision by pieces of length r of α contains almost only ϵ -monotone components (which are therefore close to vertical geodesic segments).

Proposition [7.2.2](#) provides us with the existence of such an appropriate scale .

Lemma 7.2.1. *Let $k \geq 1$, $c \geq 0$ and $\epsilon > 0$. There exists $M(k, c, \mathfrak{M}, \epsilon)$ such that for all $r \geq M$, $N \geq M$ and for all non ϵ -monotone, (k, c) -quasigeodesic segment $\alpha : [0, r] \rightarrow X \mathfrak{M} Y$ we have*

$$\sum_{j=0}^{N-1} \Delta h \left(\alpha \left(\frac{jr}{N} \right), \alpha \left(\frac{(j+1)r}{N} \right) \right) - \Delta h(\alpha(0), \alpha(r)) \geq_{k, c, \mathfrak{M}} \epsilon r \quad (7.15)$$

Proof. Since α is non ϵ -monotone, there exist $t_1, t_3 \in [0, r]$ such that

$$h(\alpha(t_1)) = h(\alpha(t_3)) \quad \text{and} \quad |t_1 - t_3| > \epsilon r \quad (7.16)$$

We can assume without loss of generality that $h(\alpha(0)) \leq h(\alpha(t_1)) \leq h(\alpha(r))$ with $t_1 < t_3$. Since α is a (k, c) -quasigeodesic we have $d_{\mathfrak{M}}(\alpha(t_1), \alpha(t_3)) \geq \frac{\epsilon r}{k} - c$. By Corollary [4.3.4](#) of the first part of this manuscript, there exists $M(\mathfrak{M})$ such that $d_{\mathfrak{M}} \leq d_X + d_Y + M$. Then at least one of the two following inequalities holds:

1. $d_X(\alpha^X(t_1), \alpha^X(t_3)) \geq_{\varkappa} \frac{\varepsilon}{2k}r - M(\varkappa, c)$
2. $d_Y(\alpha^Y(t_1), \alpha^Y(t_3)) \geq_{\varkappa} \frac{\varepsilon}{2k}r - M(\varkappa, c)$

Let us assume that the first inequality is true. By Lemma 3.1.2 applied to the geodesic segment $[\alpha^X(t_1), \alpha^X(t_3)]$ we have

$$\begin{aligned} h^+([\alpha^X(t_1), \alpha^X(t_3)]) &\geq d_X(\alpha^X(t_1), \alpha^X(t_3)) - \Delta h(\alpha^X(t_1), \alpha^X(t_3)) - 96\delta \\ &= d_X(\alpha^X(t_1), \alpha^X(t_3)) - 96\delta \end{aligned}$$

Hence by Proposition 3.2.1 and the assumed inequality, there exists $t_2 \in [t_1, t_3]$ such that

$$\begin{aligned} \Delta h(\alpha(t_1), \alpha(t_2)) &\geq_{\varkappa} \frac{\varepsilon r}{k} - \delta \log_2(d_{\varkappa}(\alpha(t_1), \alpha(t_3))) - M(\varkappa, c) \\ &\geq_{\varkappa} \frac{\varepsilon r}{k} - \delta \log_2(r) - M(\varkappa, c) \end{aligned}$$

Similarly, assuming the second inequality provides us with the same lower-bound on $\Delta h(\alpha(t_1), \alpha(t_2))$. Furthermore there exists $M(\varepsilon, \varkappa, c)$ such that for $r \geq M$ we have $\frac{1}{2}\varepsilon r \geq \delta \log_2(r) + M(\varkappa, c)$, hence

$$\Delta h(\alpha(t_1), \alpha(t_2)) \geq_{\varkappa} \frac{\varepsilon r}{2k} \quad (7.17)$$

Furthermore $\forall i \in \{1, 2, 3\}$ there exists $n_i \in \{0, \dots, N-1\}$ such that

$$\frac{n_i r}{N} \leq t_i \leq \frac{(n_i + 1)r}{N}.$$

Computing the sum of the successive differences of heights provides us with

$$\begin{aligned} &\sum_{j=0}^{N-1} \Delta h\left(\alpha\left(\frac{jr}{N}\right), \alpha\left(\frac{(j+1)r}{N}\right)\right) \\ &\geq \Delta h\left(\alpha(0), \alpha\left(\frac{n_1 r}{N}\right)\right) + \Delta h\left(\alpha\left(\frac{n_1 r}{N}\right), \alpha\left(\frac{n_2 r}{N}\right)\right) + \Delta h\left(\alpha\left(\frac{n_2 r}{N}\right), \alpha\left(\frac{n_3 r}{N}\right)\right) \\ &\quad + \Delta h\left(\alpha\left(\frac{n_3 r}{N}\right), \alpha(r)\right) \\ &\geq \Delta h(\alpha(0), \alpha(t_1)) + \Delta h(\alpha(t_1), \alpha(t_2)) + \Delta h(\alpha(t_2), \alpha(t_3)) + \Delta h(\alpha(t_3), \alpha(r)) \\ &\quad - 6\left(\frac{kr}{N} + c\right), \quad \text{because } h \text{ is Lipschitz, } \alpha \text{ is a quasigeodesic and by the triangle inequality,} \\ &\geq \Delta h(\alpha(0), \alpha(r)) + 2\Delta h(\alpha(t_1), \alpha(t_2)) - 6\left(\frac{kr}{N} + c\right), \quad \text{since } h(\alpha(t_1)) = h(\alpha(t_3)). \end{aligned}$$

Using inequality (7.17) we have

$$\begin{aligned} \sum_{j=0}^{N-1} \Delta h\left(\alpha\left(\frac{jr}{N}\right), \alpha\left(\frac{(j+1)r}{N}\right)\right) - \Delta h(\alpha(0), \alpha(r)) &\geq_{\varkappa} \frac{\varepsilon r}{2k} - \frac{6kr}{N} - 6c \\ &\geq_{k, c, \varkappa} \varepsilon r, \quad \text{since we assumed } N \geq M(k, c, \varkappa, \varepsilon). \end{aligned}$$

□

The next lemma asserts that, at some scale, most segments of a quasigeodesic are ε -monotone.

Proposition 7.2.2. *Let $k \geq 1$, $c \geq 0$, $\varepsilon > 0$ and let S be an integer. There exists $M(k, c, \varkappa, \varepsilon)$ such that for $r_0 \geq M$ and $N \geq M$ the following occurs. let us denote by $L = N^S r_0$. Let $\alpha : [0, L] \rightarrow X \varkappa Y$ be a*

(k, c) -quasigeodesic segment. For all $s \in \{0, \dots, S\}$ we cut α into segments of length $N^s r_0$, and we denote by A_s the set of these segment, that is

$$A_s := \left\{ \alpha \left([kN^s r_0, (k+1)N^s r_0] \right) \mid k \in \{0, \dots, N^{S-s} - 1\} \right\},$$

and let $\delta_s(\alpha)$ be the proportion of segments in A_s which are not ε -monotone

$$\delta_s(\alpha) := \frac{\#\{\beta \in A_s \mid \beta \text{ is not } \varepsilon\text{-monotone}\}}{\#A_s}. \quad (7.18)$$

Then

$$\sum_{s=1}^S \delta_s(\alpha) \leq_{k,c,\varkappa} \frac{1}{\varepsilon} \quad (7.19)$$

Proof. The idea is to cut α into N segments of equal length, then to apply Lemma 7.2.1 to the elements of this decomposition which are not ε -monotone. Afterwards we decompose every piece of this decomposition into N segments of equal length to which we apply Lemma 7.2.1 if they are not ε -monotone. The result follows by doing this sub-decomposition S times in a row. To begin with, we need to deal with α being ε -monotone or not. Hence $\delta_S(\alpha) = 0$ or 1 and in either case thanks to Lemma 7.2.1 we have

$$\sum_{j=0}^{N-1} \Delta h(\alpha(jN^{S-1}r_0), \alpha((j+1)N^{S-1}r_0)) \geq_{k,c,\varkappa} \Delta h(\alpha(0), \alpha(L)) + \delta_S(\alpha)\varepsilon L. \quad (7.20)$$

Then for all $j \in \{0, \dots, N-1\}$ such that $\alpha([jN^{S-1}r_0, (j+1)N^{S-1}r_0])$ is not ε -monotonous

$$\begin{aligned} & \sum_{k=0}^{N-1} \Delta h(\alpha(kN^{S-2}r_0 + jN^{S-1}r_0), \alpha((k+1)N^{S-2}r_0 + jN^{S-1}r_0)) \\ & \geq_{k,c,\varkappa} \Delta h(\alpha(jN^{S-1}r_0), \alpha((j+1)N^{S-1}r_0)) + \frac{\varepsilon L}{N}, \end{aligned}$$

which happens $N\delta_{S-1}(\alpha)$ times. Therefore we have that

$$\begin{aligned} \sum_{i=0}^{N^2-1} \Delta h(\alpha(iN^{S-2}r_0), \alpha((i+1)N^{S-2}r_0)) & \geq_{k,c,\varkappa} \Delta h(\alpha(0), \alpha(r)) + \delta_S(\alpha)\varepsilon L + N\delta_{S-1}(\alpha)\frac{\varepsilon L}{N} \\ & \geq_{k,c,\varkappa} \Delta h(\alpha(0), \alpha(r)) + (\delta_S(\alpha) + \delta_{S-1}(\alpha))\varepsilon L. \end{aligned}$$

By doing this another $S-2$ times we obtain

$$\sum_{i=0}^{N^S-1} \Delta h(\alpha(ir_0), \alpha((i+1)r_0)) \geq_{k,c,\varkappa} \Delta h(\alpha(0), \alpha(r)) + \varepsilon L \sum_{s=1}^S \delta_s(\alpha).$$

Furthermore we have the following estimate using the Lipschitz property of h

$$\begin{aligned} \sum_{i=0}^{N^S-1} \Delta h(\alpha(ir_0), \alpha((i+1)r_0)) & \leq \sum_{i=0}^{N^S-1} d_{\varkappa}(\alpha(ir_0), \alpha((i+1)r_0)) \\ & \leq N^S(kr_0 + c) \leq 2kL, \quad \text{with } r_0 \geq \frac{c}{k}. \end{aligned}$$

Hence

$$\sum_{s=1}^S \delta_s(\alpha) \leq_{k,c,\varkappa} \frac{1}{\varepsilon L} 2kL \leq_{k,c,\varkappa} \frac{1}{\varepsilon}. \quad (7.21)$$

□

7.3 Height respecting tetrahedric quadrilaterals

In this subsection we show that a coarse tetrahedric quadrilateral whose sides are vertical geodesics, has two vertices on the same X -horosphere, and the other two on the same Y -horosphere (see [6.0.10](#) for the definition of such horospheres). We call such a configuration a tetrahedron configuration.

Definition 7.3.1. (*Orientation*) We define the orientation function on the paths of $X \bowtie Y$ as follows. For all $T > 0$ and $\gamma : [0, T] \rightarrow X \bowtie Y$ we have

$$\text{orientation}(\gamma) = \begin{cases} \uparrow & \text{if } h(\gamma(0)) < h(\gamma(T)), & \text{upward} \\ \downarrow & \text{if } h(\gamma(0)) > h(\gamma(T)), & \text{downward} \end{cases} \quad (7.22)$$

Proposition 7.3.2. (*Tetrahedron lemma*)

Let $a_1, a_2, b_1, b_2 \in X \bowtie Y$. Let $D > 1$ and for $i, j \in \{1, 2\}$, let $V_{ij} : [0, l_{ij}] \rightarrow X \bowtie Y$ be vertical geodesic segments linking the D -neighbourhood of a_i to the D -neighbourhood of b_j , and diverging quickly from each other. More specifically, we assume for all $i, j \in \{1, 2\}$:

- (a) $d(V_{ij}(0), a_i) \leq D$
- (b) $d(V_{ij}(l_{ij}), b_j) \leq D$
- (c) $d(V_{i1}(t), \text{im}(V_{i2})) \geq \frac{t}{10} - D, \forall t \in [0, l_{i1}]$
- (d) $d(V_{1j}(l_{1j} - t), \text{im}(V_{2j})) \geq \frac{t}{10} - D, \forall t \in [0, l_{1j}]$

If for all $i, j \in \{1, 2\}$, $l_{ij} > 2D$ and the vertical geodesic segments V_{ij} share the same orientation, then there exists a constant $M(\bowtie)$ such that one of the two following statements holds:

1. The four vertical geodesics V_{ij} are upward oriented and a_2 is in the (MD) -neighbourhood of the X -horosphere containing a_1 , and b_2 is in the (MD) -neighbourhood of the Y -horosphere containing b_1 . Otherwise stated, we have $d_Y(a_1^Y, a_2^Y) \leq MD$ and $d_X(b_1^X, b_2^X) \leq MD$.
2. The four vertical geodesics V_{ij} are downward oriented and a_2 is in the (MD) -neighbourhood of the Y -horosphere containing a_1 , and b_2 is in the (MD) -neighbourhood of the X -horosphere containing b_1 . Otherwise stated, we have $d_X(a_1^X, a_2^X) \leq MD$ and $d_Y(b_1^Y, b_2^Y) \leq MD$.

Proposition [7.3.2](#) is illustrated in Figure [7.4](#)

Proof.

For all $i, j \in \{1, 2\}$ let us denote by

$$a_i = (a_i^X, a_i^Y); b_j = (b_j^X, b_j^Y); V_{ij} = (V_{ij}^X, V_{ij}^Y). \quad (7.23)$$

The hypothesis (a) gives us

$$d(V_{i1}(0), V_{i2}(0)) \leq d(V_{i1}(0), a_i) + d(a_i, V_{i2}(0)) \leq 2D \quad (7.24)$$

By hypothesis (b)

$$d(V_{1j}(l_{1j}), V_{2j}(l_{2j})) \leq 2D$$

Without loss of generality we can assume that for all $i, j \in \{1, 2\}$ $\text{orientation}(V_{ij}) = \uparrow$, which means that $h(a_i) \leq h(b_j)$. Then $\forall i, j \in \{1, 2\}$ and $t \in [0, l_{i1}]$ we have $h(V_{ij}(t)) = t + h(V_{ij}(0))$, hence

$$\begin{aligned} h(V_{ij}^X(t)) &= t + h(V_{ij}(0)) \\ h(V_{ij}^Y(t)) &= -t - h(V_{ij}(0)) \end{aligned}$$

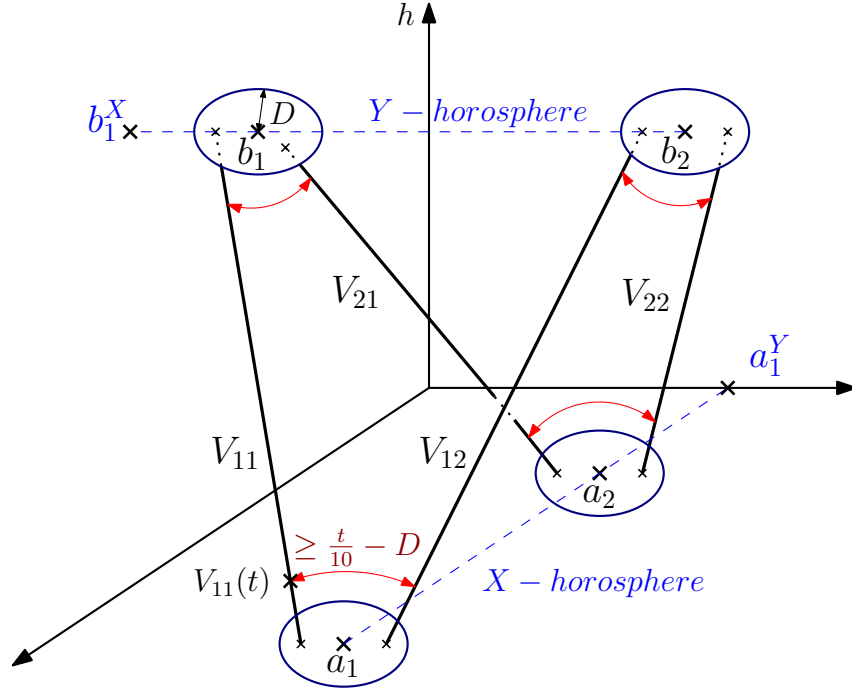
Figure 7.4: A coarse vertical quadrilateral of Proposition 7.3.2

Since X and Y are Busemann convex spaces, $\forall i, j \in \{1, 2\}$

$$t \mapsto d_Y(V_{i1}^Y(t), V_{i2}^Y(t)) \text{ is convex on } [0, \min(l_{i1}, l_{i2})].$$

$$t \mapsto d_X(V_{1j}^X(l_{1j} - t), V_{2j}^X(l_{2j} - t)) \text{ is convex on } [0, \min(l_{1j}, l_{2j})].$$

These two applications are also bounded by $2D$ on the end-points of the intervals, hence on all the intervals. Therefore

$$\forall t \in [0, \min(l_{i1}, l_{i2})], d_Y(V_{i1}^Y(t), V_{i2}^Y(t)) \leq 2D \quad (7.25)$$

$$\forall t \in [0, \min(l_{1j}, l_{2j})], d_X(V_{1j}^X(l_{1j} - t), V_{2j}^X(l_{2j} - t)) \leq 2D$$

We can assume without loss of generality that $l_{11} \leq l_{21}$ and that $l_{12} \leq l_{22}$. Then

$$d_X(V_{11}^X(0), V_{21}^X(l_{21} - l_{11})) \leq 2D \quad (7.26)$$

$$d_X(V_{12}^X(0), V_{22}^X(l_{22} - l_{12})) \leq 2D \quad (7.27)$$

Let us denote $\Delta l_1 = l_{21} - l_{11}$ and $\Delta l_2 = l_{22} - l_{12}$, our goal is to show that these two real numbers are sufficiently close. We have $\forall i, j \in \{1, 2\}$

$$\Delta h(a_i, b_j) - 2D \leq l_{ij} \leq \Delta h(a_i, b_j) + 2D$$

By subtracting these inequalities we get

$$-h(a_2) + h(a_1) - 4D \leq l_{21} - l_{11} \leq -h(a_2) + h(a_1) + 4D$$

$$-h(a_2) + h(a_1) - 4D \leq l_{22} - l_{12} \leq -h(a_2) + h(a_1) + 4D$$

Then $|\Delta l_1 - \Delta l_2| \leq 8D$. However

$$\begin{aligned} d_X(V_{21}^X(\Delta l_1), V_{22}^X(\Delta l_1)) &\leq d_X(V_{21}^X(\Delta l_1), V_{11}^X(0)) + d_X(V_{11}^X(0), V_{12}^X(0)) \\ &\quad + d_X(V_{12}^X(0), V_{22}^X(\Delta l_2)) + d_X(V_{22}^X(\Delta l_2), V_{22}^X(\Delta l_1)). \end{aligned}$$

By the inequalities (7.26) and (7.27) we obtain

$$\begin{aligned} d_X(V_{21}^X(\Delta l_1), V_{22}^X(\Delta l_1)) &\leq 2D + d_X(V_{11}^X(0), V_{12}^X(0)) + 2D + |\Delta l_1 - \Delta l_2| \\ &\leq 4D + 2D + 8D \leq 14D. \end{aligned} \quad (7.28)$$

By using assumption (c) and the characterisation of the distance on horospherical products we have

$$\begin{aligned} -D + \frac{\Delta l_1}{10} &\leq d_{\varkappa}(V_{21}(\Delta l_1), V_{22}(\Delta l_1)) \\ &\leq d_X(V_{21}^X(\Delta l_1), V_{22}^X(\Delta l_1)) + d_Y(V_{21}^Y(\Delta l_1), V_{22}^Y(\Delta l_1)) \\ &\quad - \Delta h(V_{21}(\Delta l_1), V_{22}(\Delta l_1)) + M(\varkappa), \quad \text{by Corollary 4.3.4,} \\ &\leq d_X(V_{21}^X(\Delta l_1), V_{22}^X(\Delta l_1)) + 2D + M, \quad \text{by inequality (7.25)} \\ &\leq 16D + M, \quad \text{by inequality (7.28),} \end{aligned}$$

which provides us with $\Delta l_1 \leq 10(16D + M + D) = 170D + 10M$. We have

$$\begin{aligned} d_X(a_1^X, a_2^X) &\leq d_X(a_1^X, V_{11}^X(0)) + d_X(V_{11}^X(0), V_{21}^X(0)) + d_X(V_{21}^X(0), a_2^X) \\ &\leq d_X(V_{11}^X(0), V_{21}^X(\Delta l_1)) + d_X(V_{21}^X(\Delta l_1), V_{21}^X(0)) + 2D \\ &\leq 2D + 170D + 10M + 2D \leq 174D + 10M, \quad \text{by inequality (7.26).} \end{aligned}$$

From this inequality we deduce that $|h(a_1) - h(a_2)| \leq 174D + 10M \leq_{\varkappa} D$. Similarly we deduce the following inequalities.

$$\begin{aligned} d_Y(b_1^Y, b_2^Y) &\leq_{\varkappa} D, \\ |h(b_1) - h(b_2)| &\leq_{\varkappa} D. \end{aligned}$$

□

Four points which satisfies the assumption of Proposition 7.3.2 are called a vertical quadrilateral with nodes of scale D .

7.4 Orientation and tetrahedric quadrilaterals

From now on we fix a (k, c) -quasi-isometry $\Phi : X \varkappa Y \rightarrow X \varkappa Y$. The second tetrahedron configuration consists of two points on an X -horosphere and pairwise linked to two points on a Y -horosphere by four vertical geodesic segments.

The following proposition 7.4.2 states that if two points on an X -horosphere are sufficiently far from each other, if two points on an Y -horosphere are sufficiently far from each other and if the vertical geodesic segments have ε -monotone images under a (k, c) -quasi-isometry Φ , then all the images of the vertical geodesic segments by Φ share the same orientation.

We first show that there exists a constant $M(k, c, \varkappa)$ such that the concatenation of two consecutive ε -monotone quasigeodesic segments sharing the same orientation is an $M\varepsilon$ -monotone quasigeodesic segment. This result will only be used in the proof of Proposition 7.4.2.

Lemma 7.4.1. *Let $k > 1, c > 0, D > 0, \varepsilon > 0, T \geq \frac{D+2c}{3\varepsilon}$ and let $\gamma : [0, T] \mapsto X \varkappa Y$ and $\gamma' : [0, T] \mapsto X \varkappa Y$ be two ε -monotone, (k, c) -quasigeodesic segments such that:*

1. $\text{orientation}(\gamma) = \text{orientation}(\gamma')$
2. $d_{\varkappa}(\gamma(T), \gamma'(0)) \leq D$

Let $\tilde{\gamma} : [0, 2T] \rightarrow X \rtimes Y$ be the concatenation of γ and γ'

$$\tilde{\gamma}(t) = \begin{cases} \gamma(t) & \text{if } t \in [0, T] \\ \gamma'(t-T) & \text{if } t \in]T, 2T] \end{cases} \quad (7.29)$$

Then there exists $M(k, c, \rtimes)$ such that $\tilde{\gamma}$ is an $M\varepsilon$ -monotone, $(k, M\varepsilon T)$ -quasigeodesic segment.

Proof. We can assume without loss of generality that γ and γ' are upward oriented, we first show that there exists $M(k, c, \delta)$ such that $\tilde{\gamma}$ is $M\varepsilon$ -monotone. Let $t_1, t_2 \in [0, 2T]$ such that $h(\tilde{\gamma}(t_1)) = h(\tilde{\gamma}(t_2))$. If both t_1 and t_2 are in $[0, T]$ or both are in $]T, 2T]$, there is nothing to do since γ and γ' are ε -monotone. Then we can assume without loss of generality that $t_1 \in [0, T]$ and $t_2 \in]T, 2T]$. Since γ is upward oriented we have $h(\gamma(0)) < h(\gamma(T))$, therefore, because γ is ε -monotone and continuous, we have

$$h(\gamma(t_1)) \leq h(\gamma(T)) + \varepsilon T, \quad (7.30)$$

otherwise, by continuity there exists t'_1 in $[0, t_1]$ such that $h(\gamma(t'_1)) = h(\gamma(T))$ contradicting the ε -monotonicity. Two cases arise:

- (a) $\Delta h(\gamma'(t_2 - T), \gamma'(0)) \leq \varepsilon T$
- (b) $\Delta h(\gamma'(t_2 - T), \gamma'(0)) > \varepsilon T$

Let us consider the first case (a). We know that $h(\gamma(t_1)) = h(\tilde{\gamma}(t_1)) = h(\tilde{\gamma}(t_2)) = h(\gamma'(t_2 - T))$ and that $\Delta h(\gamma(T), \gamma'(0)) \leq D$, then by the triangle inequality we have

$$\Delta h(\gamma(t_1), \gamma(T)) = \Delta h(\gamma'(t_2 - T), \gamma(T)) \leq \Delta h(\gamma'(t_2 - T), \gamma'(0)) + \Delta h(\gamma'(0), \gamma(T)) \leq \varepsilon T + D$$

According to Corollary [7.1.5](#) h is a $(k, M\varepsilon T)$ -quasi-isometry along ε -monotone quasigeodesics. Hence

$$\begin{aligned} |t_1 - T| &\leq k\Delta h(\gamma(t_1), \gamma(T)) + M\varepsilon T \leq (k + M)\varepsilon T + kD \leq (2k + M)\varepsilon T, \text{ quadby assumption on } T, \\ |t_2 - T| &\leq k\Delta h(\gamma'(t_2 - T), \gamma'(0)) + M\varepsilon T \leq (k + M)\varepsilon T \end{aligned}$$

Therefore by the triangle inequality we obtain $|t_1 - t_2| \leq (\frac{3}{2}k + M)\varepsilon(2T)$.

We consider now the second case (b). By Corollary [7.1.5](#), h is a $(k, M\varepsilon T)$ -quasi-isometry, therefore

$$\Delta h(\gamma'(t_2 - T), \gamma'(0)) \geq \frac{1}{k}|t_2 - T| - M\varepsilon T$$

Furthermore, γ' is upward oriented, hence we have that $h(\gamma'(0)) < h(\gamma'(t_2 - T))$, otherwise, as for γ , by continuity one can construct $t'_2 \in [t_2, T + T']$ contradicting the ε -monotonicity of γ' . Hence we have

$$h(\gamma'(t_2 - T)) \geq h(\gamma'(0)) + \frac{1}{k}|t_2 - T| - M\varepsilon T$$

In combination with inequality [\(7.30\)](#) it provides us with

$$\begin{aligned} h(\gamma(t_1)) &\leq h(\gamma(T)) + \varepsilon T \leq h(\gamma'(0)) + D + \varepsilon T \\ &\leq h(\gamma'(t_2 - T)) - \frac{1}{k}|t_2 - T| + D + (1 + M)\varepsilon T \end{aligned}$$

However $h(\gamma(t_1)) = h(\gamma'(t_2 - T))$ by definition of t_1 and t_2 , therefore $0 \leq -\frac{1}{k}|t_2 - T| + D + (1 + M)\varepsilon T$, which gives

$$|t_2 - T| \leq (1 + M)k\varepsilon T + kD \leq 3Mk\varepsilon T. \quad (7.31)$$

Hence

$$\Delta h(\gamma'(t_2 - T), \gamma'(0)) \leq d_{\rtimes}(\gamma'(t_2 - T), \gamma'(0)) \leq k|t_2 - T| + c \leq (3Mk^2 + 1)\varepsilon T$$

Since $h(\gamma'(t_2 - T)) = h(\gamma(t_1))$, thanks to the triangle inequality we obtain

$$\begin{aligned} \Delta h(\gamma(t_1), \gamma(T)) &\leq \Delta h(\gamma(t_1), \gamma'(0)) + \Delta h(\gamma'(0), \gamma(T)) \\ &\leq (3Mk^2 + 1)\varepsilon T + D \leq (3Mk^2 + 2)\varepsilon T \end{aligned} \quad (7.32)$$

Both inequalities (7.31) and (7.32) in combination with the fact that h is a $(k, M\varepsilon T)$ -quasigeodesic segment provide us with

$$\begin{aligned} |t_1 - t_2| &= |t_1 - T| + |T - t_2| \leq k(3Mk^2 + 2)\varepsilon T + M\varepsilon T + 3Mk\varepsilon T \\ &\leq 9k^3M\varepsilon T \leq \frac{9k^3M}{2}\varepsilon(2T) \quad , \text{ since } k \geq 1, M \geq 1. \end{aligned}$$

In the view of cases (a) and (b) we conclude that $\tilde{\gamma}$ is $\frac{9k^3M}{2}\varepsilon$ -monotone.

To prove that $\tilde{\gamma}$ is a $(k, 3M\varepsilon T)$ -quasigeodesic segment, we must check the upper-bound and lower bound required. Let $t_1, t_2 \in [0, 2T]$, as for the ε -monotonicity property, since γ and γ' are (k, c) -quasigeodesics, we can assume that $t_1 \in [0, T]$ and $t_2 \in]T, 2T]$. By the triangle inequality, the upper-bound is straightforward.

$$\begin{aligned} d_{\mathfrak{M}}(\tilde{\gamma}(t_1), \tilde{\gamma}(t_2)) &= d_{\mathfrak{M}}(\gamma(t_1), \gamma'(t_2 - T)) \\ &\leq d_{\mathfrak{M}}(\gamma(t_1), \gamma(T)) + d_{\mathfrak{M}}(\gamma(T), \gamma'(0)) + d_{\mathfrak{M}}(\gamma'(0), \gamma'(t_2 - T)) \\ &\leq k(T - t_1) + c + D + k(t_2 - T) + c = k|t_2 - t_1| + 2c + D \\ &\leq k|t_2 - t_1| + 3\varepsilon T \quad , \text{ by the assumed lower bound on } T. \end{aligned}$$

Last inequality holds because γ and γ' are (k, c) -quasigeodesics. To prove the lower-bound we will proceed similarly as for the ε -monotonicity. We have

$$\begin{aligned} d_{\mathfrak{M}}(\tilde{\gamma}(t_1), \tilde{\gamma}(t_2)) &= d_{\mathfrak{M}}(\gamma(t_1), \gamma'(t_2 - T)) \\ &\geq \Delta h(\gamma(t_1), \gamma'(t_2 - T)), \quad \text{ since } h \text{ is Lipschitz.} \end{aligned}$$

Similarly to inequality (7.30) we have

$$h(\gamma'(t_2 - T)) \geq h(\gamma'(0)) - \varepsilon T. \quad (7.33)$$

Therefore

$$\begin{aligned} \Delta h(\gamma(t_1), \gamma'(t_2 - T)) &\geq h(\gamma'(t_2 - T)) - h(\gamma(t_1)) \\ &= (h(\gamma'(t_2 - T)) + \varepsilon T) - h(\gamma'(0)) + h(\gamma'(0)) - h(\gamma(T)) + h(\gamma(T)) - (h(\gamma(t_1)) - \varepsilon T) - 2\varepsilon T \\ &= |(h(\gamma'(t_2 - T)) + \varepsilon T) - h(\gamma'(0))| + |h(\gamma(T)) - (h(\gamma(t_1)) - \varepsilon T)| \\ &\quad + h(\gamma'(0)) - h(\gamma(T)) - 2\varepsilon T \quad , \text{ by inequalities (7.30) and (7.33),} \\ &\geq |h(\gamma'(t_2 - T)) - h(\gamma'(0))| + |h(\gamma(T)) - h(\gamma(t_1))| - D - 4\varepsilon T \quad , \text{ by the triangle inequality,} \\ &\geq \frac{1}{k}|t_2 - T| - M\varepsilon T + \frac{1}{k}|T - t_1| - M\varepsilon T - D - 4\varepsilon T, \quad \text{ because } h \text{ is a } (k, M\varepsilon T)\text{-quasigeodesic.} \end{aligned}$$

Hence

$$\begin{aligned} d_{\mathfrak{M}}(\tilde{\gamma}(t_1), \tilde{\gamma}(t_2)) &\geq \Delta h(\gamma(t_1), \gamma'(t_2 - T)) \\ &\geq \frac{1}{k}(t_2 - t_1) - D - (2M + 4)\varepsilon T \geq \frac{1}{k}(t_2 - t_1) - 7M\varepsilon T. \end{aligned}$$

Which is the lower-bound we expected and proves that $\tilde{\gamma}$ is a $(k, 7M\varepsilon T)$ -quasigeodesic. \square

Proposition 7.4.2. *Let $h \in \mathbb{R}$ and let $k \geq 1$, $c \geq 0$ and $\varepsilon > 0$. Let Φ be a self (k, c) -quasi-isometry of $X \rtimes Y$. Let $D > 1$ and $R > \frac{k2D+c}{\varepsilon}$. For $i, j \in \{1, 2\}$ let a_i, b_j be four points of $X \rtimes Y$ verifying $d(a_1, a_2) > 10kM\varepsilon R + 2kc$ and $d(b_1, b_2) \geq 10kM\varepsilon R + 2kc$, where M is the constant involved in Lemma 7.4.1, and let $V_{i,j} : [0, R] \rightarrow X \rtimes Y$ be four vertical geodesic segments linking the D -neighbourhood of a_i to the D -neighbourhood of b_j , such that:*

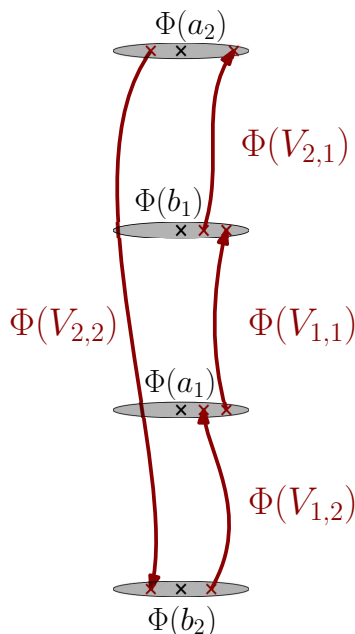

Figure 7.5: Case (a) in proof of Proposition 7.4.2

- $h(V_{11}(0)) = h(V_{22}(0)) = h(a_1) = h(a_2) = h$
- $h(V_{11}(R)) = h(V_{22}(R)) = h(b_1) = h(b_2) = h + R$
- $h(V_{12}(0)) = h(V_{21}(0)) = h + R$
- $h(V_{12}(R)) = h(V_{21}(R)) = h$
- $\Phi \circ V_{i,j}$ is ε -monotone

Then the following statement holds:

$$\text{orientation}(\Phi \circ V_{11}) = \text{orientation}(\Phi \circ V_{22})$$

Proof. Up to the additive constant D , one can consider $V_{1,1} \cup V_{2,1} \cup V_{2,2} \cup V_{1,2}$ as a coarse quadrilateral composed with a_i and b_j as its vertices, and with $V_{i,j}$ as its edges. To make the proof easier to follow, we shall use a vector of arrows to describe the orientations of the edges of the quadrilateral in play as follows:

$$\text{orientation}(V_{1,1}, V_{2,1}, V_{2,2}, V_{1,2}) = (\uparrow, \downarrow, \uparrow, \downarrow)$$

Similarly, we consider orientations of the image of $V_{1,1} \cup V_{2,1} \cup V_{2,2} \cup V_{1,2}$ by Φ as the successive orientations of the paths $\Phi \circ V_{i,j}$. We will proceed by contradiction to prove the lemma. Let us assume that $\text{orientation}(\Phi \circ V_{1,1}) \neq \text{orientation}(\Phi \circ V_{2,2})$. We can assume without loss of generality that $\text{orientation}(\Phi(V_{1,1})) = \uparrow$, therefore $\text{orientation}(\Phi(V_{2,2})) = \downarrow$.

Hence there are four possible orientations for $\Phi(V_{1,1} \cup V_{2,1} \cup V_{2,2} \cup V_{1,2})$:

- (a) $(\uparrow, \uparrow, \downarrow, \uparrow)$ (b) $(\uparrow, \uparrow, \downarrow, \downarrow)$ (c) $(\uparrow, \downarrow, \downarrow, \uparrow)$ (d) $(\uparrow, \downarrow, \downarrow, \downarrow)$

Let us consider the case (a) (illustrated in Figure 7.5), we have $\text{orientation}(\Phi(V_{2,1})) = \uparrow$ and $\text{orientation}(\Phi(V_{1,2})) = \uparrow$. Hence we have

$$\text{orientation}(\Phi(V_{1,2})) = \text{orientation}(\Phi(V_{1,1})) = \text{orientation}(\Phi(V_{2,1}))$$

Furthermore Φ is a (k, c) -quasi-isometry and both $V_{1,2}(R)$ and $V_{1,1}(0)$ are close to a_1 , hence

$$d_{\varkappa}(\Phi(V_{1,2}(R)), \Phi(V_{1,1}(0))) \leq k2D + c$$

Similarly we have

$$d_{\varkappa}(\Phi(V_{1,1}(R)), \Phi(V_{2,1}(0))) \leq k2D + c$$

Then by Lemma 7.4.1, there exists $M(k, c, \varkappa)$ such that the concatenation of $\Phi(V_{1,2})$, $\Phi(V_{1,1})$ and $\Phi(V_{2,1})$ is an $M\varepsilon$ -monotone $(k, M\varepsilon T)$ -quasigeodesic. Therefore by Proposition 7.1.4, there exists a constant $M(k, c, \varkappa)$ and a vertical geodesic segment \tilde{V} such that

$$d_{\text{Hff}}(\tilde{V}, \Phi(V_{1,2}) \cup \Phi(V_{1,1}) \cup \Phi(V_{2,1})) \leq M\varepsilon R \quad (7.34)$$

Furthermore, applying Proposition 7.1.4 on $\Phi(V_{2,2})$ provides us with the existence of a vertical geodesic segment \tilde{V}' such that

$$d_{\text{Hff}}(\tilde{V}', \Phi(V_{2,2})) \leq M\varepsilon R. \quad (7.35)$$

Moreover $d_{\varkappa}(V_{2,2}(0), V_{2,1}(R)) \leq 2D$ (the two points are close to a_2) and $d_{\varkappa}(V_{2,2}(R), V_{1,2}(0)) \leq 2D$ (the two points are close to b_2), therefore \tilde{V} and \tilde{V}' are two vertical geodesics with endpoints $(k2D + c) + 2M\varepsilon R$ close to $\Phi(a_2)$ and $\Phi(b_2)$. Thereby, these two vertical geodesic segments stay close to each other, we have

$$d_{\text{Hff}}(\tilde{V}, \tilde{V}') \leq (k2D + c) + 2M\varepsilon R \leq 3M\varepsilon, \quad \text{by assumption on } R.$$

Then, we show by the triangle inequality that $\Phi(a_1)$ is close to $\Phi(V_{2,2})$.

$$d_{\varkappa}(\Phi(a_1), \Phi(V_{2,2})) \leq d_{\varkappa}(\Phi(a_1), \tilde{V}) + d_{\text{Hff}}(\tilde{V}, \tilde{V}') + d_{\text{Hff}}(\tilde{V}', \Phi(V_{2,2})) \leq 5M\varepsilon R \quad (7.36)$$

However, the assumption $d(a_1, a_2) > 10kM\varepsilon R + 2kc$ gives us that a_1 is sufficiently far from $V_{2,2}$

$$\begin{aligned} \forall t \in [0, R], d_{\varkappa}(a_1, V_{2,2}(t)) &\geq \Delta h(a_1, V_{2,2}(t)) = t \\ \text{and, } d_{\varkappa}(a_1, V_{2,2}(t)) &\geq d_{\varkappa}(a_1, a_2) - d_{\varkappa}(a_2, V_{2,2}(t)) > 10kM\varepsilon R + 2kc - t. \end{aligned}$$

Therefore

$$\begin{aligned} \forall t \in [0, R], d_{\varkappa}(\Phi(a_1), \Phi(V_{2,2}(t))) &\geq k^{-1}d_{\varkappa}(a_1, V_{2,2}(t)) - c \\ &> \frac{t + 10kM\varepsilon R + 2kc - t}{2k} - c = 5M\varepsilon R, \end{aligned}$$

Which contradicts inequality (7.36). Thereby, in case (a), $\Phi \circ V_{1,1}$ and $\Phi \circ V_{2,2}$ share the same orientation. The other three cases (b), (c) and (d) are treated similarly. We first show that $\Phi(V_{1,1} \cup V_{2,1} \cup V_{2,2} \cup V_{1,2})$ is in the $M\varepsilon R$ -neighbourhood of two vertical geodesic segments which, depending on the case, have endpoints

(b) close to $\Phi(a_1)$ and $\Phi(a_2)$.

(c) close to $\Phi(b_1)$ and $\Phi(b_2)$.

(d) close to $\Phi(a_1)$ and $\Phi(b_1)$.

Which, depending on the case, contradicts the fact that:

(b) $d_{\mathfrak{K}}(b_1, V_{2,2}(t)) > 5M\varepsilon R$.

(c) $d_{\mathfrak{K}}(a_1, V_{2,2}(t)) > 5M\varepsilon R$.

(d) $d_{\mathfrak{K}}(b_2, V_{1,1}(t)) > 5M\varepsilon R$.

□

Chapter 8

Measure and Box-tiling

8.1 Appropriate measure and horopointed admissible space

In the setting of horospherical product, an important characteristics is that they are union of products of horospheres.

As such, if one wants to endow them with a measure, it makes sense that the measure should disintegrate along these horospherical product, and should be related somehow to the measures and the geometries of the initial spaces and its horospheres.

The properties we present are satisfied when our initial space are Riemannian manifolds for instance, or graphs of bounded geometry. We will also see in Section 10 that Heintze group are another set of spaces which satisfies them, making our requirements sound.

Definition 8.1.1. (*Admissible horopointed measured metric spaces.*)

Let (X, d) be a δ -hyperbolic, Busemann, proper, geodesically complete, metric space, and let $a \in \partial X$ be a point on the Gromov boundary of X . A Borel measure μ^X on X will be said (X, a) horo-admissible if and only if (E1), (E2) and (E3) are satisfied.

(E1) (There exists a direction $a \in \partial X$ such that) μ^X is desintegrable along the height function h_a , that is

For all $z \in \mathbb{R}$, there exists a Borel measure μ_z^X on $X_z = h^{-1}(z)$ such that for any measurable set $A \subset X$

$$\mu^X(A) = \int_{z \in \mathbb{R}} \mu_z^X(A_z) dz$$

(E2) Controllable geometry for the measures μ_z^X on horospheres, there exists $M_0 \geq 288\delta$ such that

$$\forall x_1, x_2 \in X, \text{ we have } \mu_{h(x_1)}^X(D_{M_0}(x_1)) \asymp_X \mu_{h(x_2)}^X(D_{M_0}(x_2))$$

(E3) There exists $m > 0$ such that for all $z_0 \in \mathbb{R}$, and for all measurable set $U \subset X_{z_0}$

$$\forall z \leq z_0, e^{m(z_0-z)} \mu_{z_0}^X(U) \asymp_X \mu_z^X(\pi_z(U))$$

The space (X, a, d, μ^X) will be called a horo-pointed admissible metric measured space, or just admissible.

The assumption (E2), in combination with Lemma 6.0.6, provides us with a uniform control on the measure of disks of any radius.

Lemma 8.1.2. Let $r \geq M_0$. Then for all $x \in X$ we have

$$\mu_{h(x)}(D_r(x)) \asymp_X e^{m\frac{r}{2}}$$

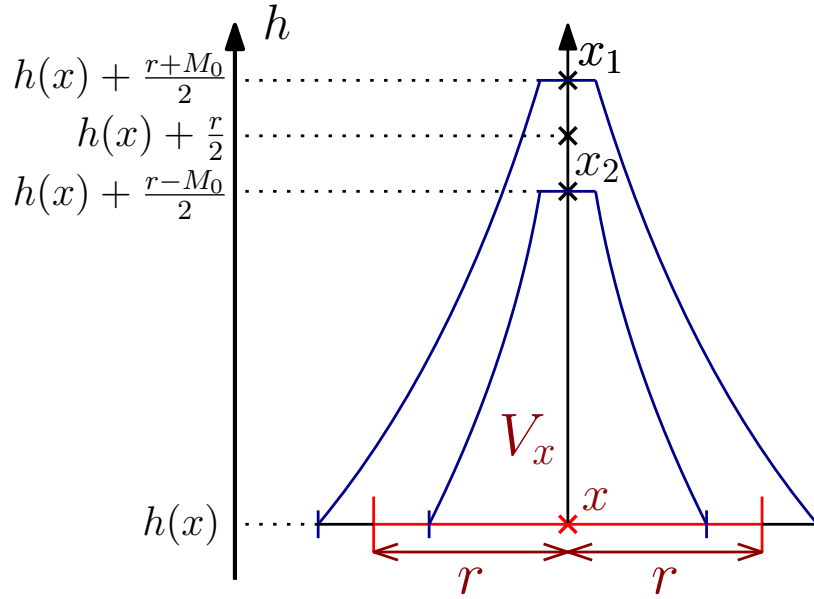

Figure 8.1: Proof of Lemma 8.1.2

Proof. The proof is illustrated in Figure 8.1. Let V_x be a vertical geodesic line containing x and let $M_0 \geq 288\delta$ be the constant involved assumption (E2). Let us denote x_1 the point of V_x at the height $h(x) + \frac{r+M_0}{2}$ and let x_2 be the point of V_x at the height $h(x) + \frac{r-M_0}{2}$. Applying Lemma 6.0.6 with $p = x_1$, $z_0 = h(x) + \frac{r+M_0}{2}$ and $z = h(x)$ provides us with

$$D_r(x) = D_{2(z_0-z)-M_0}(x) \subset \pi_{h(x)}(D_{M_0}(x_1)).$$

Similarly, applying Lemma 6.0.6 with $p = x_2$, $z_0 = h(x) + \frac{r-M_0}{2}$ and $z = h(x)$ provides us with $\pi_{h(x)}(D_{M_0}(x_2)) \subset D_r(x)$. Furthermore by assumption (E3) then assumption (E2) we have

$$\mu_{h(x)}^X(\pi_{h(x)}(D_{M_0}(x_1))) \asymp_X e^{m(\frac{r+M_0}{2})} \mu_{h(x_1)}^X(D_{M_0}(x_1)) \asymp_X e^{m\frac{r}{2}},$$

since M_0 depends only on X . Similarly we have $\mu_{h(x)}^X(\pi_{h(x)}(D_{M_0}(x_2))) \asymp_X e^{m\frac{r}{2}}$, therefore by the two previously obtained inclusions we have $\mu_{h(x)}(D_r(x)) \asymp_X e^{m\frac{r}{2}}$. \square

Heuristically, the next lemma asserts that the measure of the boundary of a disk is small in comparison to the measure of the disk.

Lemma 8.1.3. *Let M_0 be the constant involved in assumption (E2) and let M be the constant involved in Corollary 6.0.3. Let $z_0 \in \mathbb{R}$, $x_0 \in X_{z_0}$ and $\mathcal{C} \subset X_{z_0}$ be a set containing $D_{M_0}(x_0)$ and contained in $D_{2M_0}(x_0)$. Then for all $z_1 \leq z_0$, and for all $r \leq 2|z_1 - z_0| - 2M_0 - M$ we have*

$$\mu_{z_1}^X(\text{Int}_r(\pi_{z_1}^X(\mathcal{C}))) \asymp_{\kappa} \mu_{z_1}^X(\pi_{z_1}^X(\mathcal{C})).$$

This Lemma might seem to contradict Lemma 8.1.2, however the r -interior of a disk of radius R is very different from a disk of radius $R - r$ on horospheres, for R sufficiently greater than r .

Proof. Let us denote $J := \text{Int}_r(\pi_{z_1}^X(\mathcal{C}))$. By definition we have

$$\pi_{z_1}^X(\mathcal{C}) \setminus J := \{x \in \pi_{z_1}^X(\mathcal{C}) \mid d_X(x, \pi_{z_1}^X(\mathcal{C})^c) < r\} \quad (8.1)$$

At the height $z_1 + \frac{r}{2}$, let $x_1 \in \pi_{z_1 + \frac{r}{2}}^X(\mathcal{C}) \setminus \pi_{z_1 + \frac{r}{2}}^X(J)$, then, at the height z_1 , there exists $x'_1 \in \pi_{z_1}^X(\mathcal{C}) \setminus J$ such that $x_1 \in V_{x'_1}$. Furthermore by the characterisation (8.1), there exists $x'_2 \in \pi_{z_1}^X(\mathcal{C})^c$ such that $d(x'_1, x'_2) \leq r$. Then by Lemma 6.0.3, there exists $M(\delta)$ such that

$$d_X \left(V_{x'_2} \left(z_1 + \frac{r}{2} \right), V_{x'_1} \left(z_1 + \frac{r}{2} \right) \right) = d_X \left(V_{x'_2} \left(z_1 + \frac{r}{2} \right), x_1 \right) \leq M, \quad (8.2)$$

With $V_{x'_2} \left(z_1 + \frac{r}{2} \right) \in \pi_{z_1 + \frac{r}{2}}^X(\mathcal{C})^c$. Therefore by the triangle inequality and Lemma 6.0.6

$$\begin{aligned} d \left(x_1, \pi_{z_1 + \frac{r}{2}}^X(x_0) \right) &\geq -d \left(x_1, V_{x'_2} \left(z_1 + \frac{r}{2} \right) \right) + d \left(V_{x'_2} \left(z_1 + \frac{r}{2} \right), \pi_{z_1 + \frac{r}{2}}^X(x_0) \right) \\ &\geq 2|z_0 - z_1| - r - M_0 - M \end{aligned}$$

Since last inequality holds for all $x_1 \in \pi_{z_1 + \frac{r}{2}}^X(\mathcal{C}) \setminus \pi_{z_1 + \frac{r}{2}}^X(J)$, we have

$$D_{2|z_0 - z_1| - r - M_0 - M}(\pi_{z_1 + \frac{r}{2}}^X(x_0)) \subset \pi_{z_1 + \frac{r}{2}}^X(J)$$

Therefore by Lemma 6.0.6

$$D_{2|z_0 - z_1| - M_0 - M}(\pi_{z_1}^X(x_0)) \subset J$$

Moreover, $J \subset \pi_{z_1}^X(\mathcal{C}) \subset D_{2|z_0 - z_1| + M_0}(\pi_{z_1}^X(x_0))$, hence by Lemma 8.1.2

$$\mu_{z_1}^X(J) \simeq_X e^{|z_0 - z_1|m} \simeq_X \mu_{z_1}^X(\pi_{z_1}^X(\mathcal{C}))$$

□

In order to achieve a rigidity result on horospherical products, we will need another measure λ^X in the same measure class as μ^X .

Definition 8.1.4. (measure λ^X of X)

Let X be an admissible horopointed space. The measure λ^X on X is defined from a set of weighted measure λ_z^X on the level set X_z :

1. $\forall z \in \mathbb{R}, \lambda_z^X := e^{mz} \mu_z^X$
2. For all measurable set $A \subset X, \lambda^X(A) := \int_{z \in \mathbb{R}} \lambda_z^X(A_z) dz,$

where m is the constant involved in (E3).

For the Log model of the hyperbolic plane, this measure λ^X turns out to be the Lebesgue measure on \mathbb{R}^2 , and the measure μ^X is the Riemannian area. Up to a multiplicative constant, the measure λ^X is constant along the projections. By assumption (E3), the following property is immediate:

Property 8.1.5. For all measurable set $U \subset X$ we have

$$\forall z_1, z_2 \leq h^-(U), \lambda_{z_1}^X(\pi_{z_1}(U)) \simeq_X \lambda_{z_2}^X(\pi_{z_2}(U)) \quad (8.3)$$

Otherwise stated we have the following relation between two push-forwards of the measure on horospheres $\pi_{z_2} * \lambda_{z_2}^X \simeq_X \pi_{z_1} * \lambda_{z_1}^X$.

Following the fact that height level sets of $X \rtimes Y$ are direct products of horospheres, we define desintegrable measures on the horospherical products from the desintegrable measures on X and Y . We recall that $\forall z \in \mathbb{R}$

$$(X \rtimes Y)_z = X_z \times Y_{-z}$$

Definition 8.1.6. (Measure μ on $X \rtimes Y$)

Let (X, μ^X) and (Y, μ^Y) be two admissible spaces. Then for all measurable set $U \subset X \rtimes Y$, we define the measure μ on $X \rtimes Y$ by

$$\mu_{X \rtimes Y}(U) := \int_{\mathbb{R}} \mu_z^X \otimes \mu_{-z}^Y(U_z) dz.$$

For all measurable set $U \subset X \rtimes Y$ we have

$$\mu_{X \rtimes Y}(U) = \int_{\mathbb{R}} \left(\int_{y \in Y_{-z}} \mu_z^X(U_z^y) d\mu_{-z}^Y \right) dz,$$

where $U_z^y := \{x \in X \mid (x, y) \in U_z\}$. (This measure might be not well defined).

Remark 8.1.7. A couple (X, Y) of horo-pointed admissible spaces is itself called admissible if the measure $\mu_{X \rtimes Y}$ of Definition 8.1.6 is well defined.

From now on we fix two horo-pointed metric spaces X and Y , with $m > 0$ the constant of assumption (E3) for X and $n > 0$ the constant of assumption (E3) for Y . We will assume in Section 9.3 and afterwards that (X, Y) is an admissible couple with $m > n$.

We define similarly a measure $\lambda_{X \rtimes Y}$ on $X \rtimes Y$.

Definition 8.1.8. (Measure λ on $X \rtimes Y$)

Let (X, μ^X) and (Y, μ^Y) be two admissible spaces. Then for all measurable subset $U \subset X \rtimes Y$

$$\lambda_{X \rtimes Y}(U) := \int_{\mathbb{R}} \lambda_z^X \otimes \lambda_{-z}^Y(U_z) dz = \int_{\mathbb{R}} e^{(m-n)z} \mu_z^X \otimes \mu_{-z}^Y(U_z) dz$$

For all measurable subset $U \subset X \rtimes Y$ we have

$$\lambda_{X \rtimes Y}(U) = \int_{\mathbb{R}} \left(\int_{y \in Y_{-z}} \lambda_z^X(U_z^y) d\lambda_{-z}^Y \right) dz.$$

From now on, we will simply denote by μ the measure $\mu_{X \rtimes Y}$ and by λ the measure $\lambda_{X \rtimes Y}$.

8.2 Box-tiling of X

In this subsection we tile a proper, geodesically complete, Gromov hyperbolic and Busemann space X with pieces called boxes.

Definition 8.2.1. (Box at scale R)

Let X be admissible horo-pointed space. Let M_0 be the constant of (E2), let $R > 0$, let x be a point of X and let $\mathcal{C}(x)$ be a subset of $X_{h(x)}$ containing $D_{M_0}(x)$ and contained in $D_{2M_0}(x)$. Then, the box $\mathcal{B}(x, \mathcal{C}(x), R)$ is defined by

$$\mathcal{B}(x, \mathcal{C}(x), R) := \bigcup_{z \in [h(x)-R, h(x)[} \pi_z(\mathcal{C}(x))$$

We will often omit the parameter $\mathcal{C}(x)$ in the notation of a box. Later we depict an appropriate choice for these spaces $\mathcal{C}(x)$. The idea of the tiling is first to distinguish layers of thickness R , then to decompose each of these layers into disjoint boxes using a tiling of disjoint cells $\mathcal{C}(x)$ as the top of these boxes. In the Log model of the hyperbolic plane, when the cell $\mathcal{C}(x)$ is a segment of an horosphere, the associated box is a rectangle of \mathbb{R}^2 . In [10], Eskin, Fisher and Whyte tile the hyperbolic plane with translates of such a rectangle. However the space we consider might not be homogeneous, therefore we

will tile Gromov hyperbolic spaces with boxes which are generically not the translate of one another. We recall that \mathcal{N}_r refers to the r -neighbourhood of a subspace.

A subset of a metric space X is k -separated if and only any two of its elements are at least at distance k . A maximal such set for the inclusion is called *maximal separating set*. We shall denote by $\mathcal{D}(X)$ such a set.

One easily sees that a maximal separated set is then k covering. That is the union of the metric ball of radius k centred at the points of $\mathcal{D}(X)$ cover the whole space.

To construct a box tiling of X we first fix a scale $R > 0$. Let M_0 be the constant involved in assumption (E2), then we chose a $2M_0$ -maximal separating set $\mathcal{D}(X_{nR})$ of the horospheres X_{nR} , with $n \in \mathbb{Z}$. Such maximal separating sets exist since X is proper and so are X_{nR} . Let us call nuclei the points in these maximal separating sets. For every nucleus $x \in \mathcal{D}(X_{nR})$, we fix a cell $\mathcal{C}(x)$ such that $D_{M_0}(x) \subset \mathcal{C}(x) \subset D_{2M_0}(x)$. Therefore, given two different nuclei $x, x' \in \mathcal{D}(X_{nR})$, we have $D_{M_0}(x) \cap D_{M_0}(x') = \emptyset$. We choose these cells such that they are μ_{nR} measurable and such that they tile their respective horospheres:

$$\forall n \in \mathbb{Z}, \quad \bigsqcup_{x \in \mathcal{D}(X_{nR})} \mathcal{C}(x) = X_{nR}.$$

As an example, one can take Voronoi cells:

$$\mathcal{V}\mathcal{C}(x) := \{p \in X_{nR} \mid d(p, x) \leq d(p, x'), \text{ for all } x' \in \mathcal{D}(X_{nR})\}$$

These cells might not be disjoint, but a point $p \in X_{nR}$ is contained in a finite number of Voronoi cells since X is proper. Therefore, by choosing (for example thanks to an arbitrary order on $\mathcal{D}(X_{nR})$) a unique cell containing p , and removing p from the others, there exists a tiling X_{nR} by cells $\mathcal{C}(x)$.

Now, for all $n \in \mathbb{Z}$ and for all $x \in \mathcal{D}(X_{nR})$ we define the box $\mathcal{B}(x, R)$ at scale R of nucleus x by

$$\mathcal{B}(x, R) := \bigcup_{z \in [(n-1)R; nR[} \pi_z(\mathcal{C}(x))$$

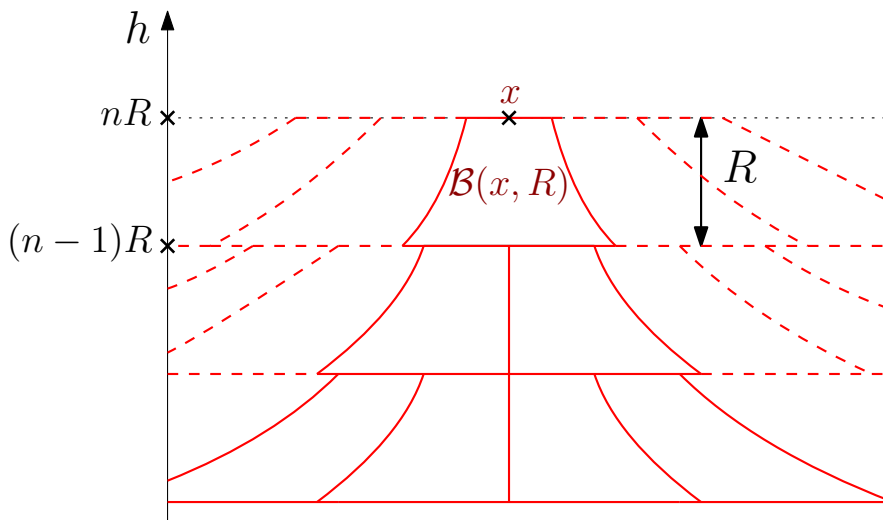

Figure 8.2: Box-tiling

In this definition, we chose $[(n-1)R; nR[$ for the boxes' heights. It is an arbitrary choice, one could prefer to use $] (n-1)R; nR]$ as these heights intervals. Moreover, to construct the horospherical product of X and Y , we will use intervals of the form $[\dots; \dots[$ for X and $] \dots; \dots]$ for Y .

We recall that the cells $\mathcal{C}(x)$ tile the horospheres X_{nR} . Furthermore there exists a unique vertical geodesic ray leaving each point of X . Consequently we have a box tiling of X at scale R :

$$X = \bigsqcup_{n \in \mathbb{Z}} \bigsqcup_{x \in \mathcal{D}(X_{nR})} \mathcal{B}(x, R) \tag{8.4}$$

The next lemma explains that any box contains and is contained in metric balls of similar scales.

Lemma 8.2.2. *There exists a constant $M(X)$ such that, for all $x \in X$ and $r > M$ there exist two boxes $\mathcal{B}(\frac{r}{2})$ and $\mathcal{B}(3r)$ verifying*

$$\mathcal{B}\left(\frac{r}{2}\right) \subset B(x, r) \subset \mathcal{B}(3r)$$

Proof is illustrated in Figure 8.3

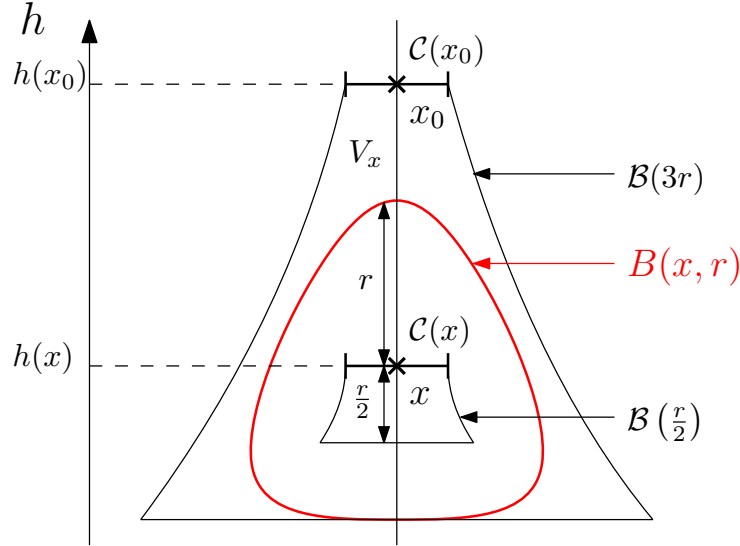

Figure 8.3: Proof of Lemma 8.2.2

Proof. Let $\mathcal{C}(x)$ be a subset of $X_{h(x)}$ containing $D(x, M_0)$ and contained in $D(x, 2M_0)$. Let us denote by $\mathcal{B}(\frac{r}{2})$ the box at scale $\frac{r}{2}$ constructed from the cell $\mathcal{C}(x)$. For all $x' \in \mathcal{B}(\frac{r}{2})$ let us denote by $x'' := V_{x'}(h(x))$ the point of $V_{x'}$ at the height $h(x)$, we have

$$d_X(x', x) \leq d_X(x', x'') + d_X(x'', x) \leq \frac{r}{2} + 2M_0 \leq r, \quad \text{for } r \geq 4M_0,$$

which gives us that $x' \in B(x, r)$. To prove the second inclusion, let us denote by V_x the unique (since X is Busemann convex) vertical geodesic ray leaving x . Let $x_0 \in \text{im}(V_x)$ such that $h(x_0) = h(x) + 2r$ and $\mathcal{C}(x_0)$ be a subset of $X_{h(x_0)}$ containing $D(x_0, M)$ and contained in $D(x_0, 2M)$. Then we claim that $B(x, r)$ is included in the box of radius $3r$ constructed from the cell $\mathcal{C}(x_0)$. Let $x' \in B(x, r)$, we recall that $d_r(x', x) := d_X(x', x) - \Delta h(x', x)$. By Lemma 3.1.2 we have that $d(V_x(h(x) + 2r), V_{x'}(h(x) + 2r)) \leq 96\delta = M$ since $r \geq d_X(x', x) \geq \frac{1}{2}d_r(x', x)$ and since the distance between two vertical geodesics is decreasing in the upward direction. Therefore $V_{x'}(h(x) + 2r) \in \mathcal{C}(x_0)$. Furthermore $\Delta h(x_0, x') \leq \Delta h(x_0, x) + \Delta h(x, x') \leq 3r$, hence $x' \in \mathcal{B}(3r)$. \square

8.3 Tiling a big box by small boxes

Let $R > 0$ and $N \in \mathbb{N}$, next result shows that a box at scale NR can be tiled with boxes at scale R .

Proposition 8.3.1. *Let M_0 be the constant of assumption (E2). Let $R > 0$ and $N \in \mathbb{N}$. Let \mathcal{B}^X be a box at scale NR , and let us denote by $h^- := h^-(\mathcal{B}^X)$ the lowest height of \mathcal{B}^X . Then there exists a box tiling at scale R of \mathcal{B}^X . Otherwise stated for all $k \in \{1, \dots, N\}$ there exists $\mathcal{D}_k(\mathcal{B}^X) \subset \mathcal{B}_{h^-+kR}^X$ such that:*

1. For all $x \in \mathcal{D}_k(\mathcal{B}^X)$, there exists a cell $\mathcal{C}(x)$ such that $D_{M_0}(x) \subset \mathcal{C}(x) \subset D_{3M_0}(x)$.

2. We have $\bigsqcup_{k=1}^N \bigsqcup_{x \in \mathcal{D}_k(\mathcal{B}^X)} \mathcal{B}^X(x, \mathcal{C}(x), R) = \mathcal{B}^X$.

Proof. To tile the box \mathcal{B}^X we first tile by cells all of its level sets at height $h^- + kR$. Let $k \in \{1, \dots, N\}$, and let $\mathcal{D}_k(\mathcal{B}^X)$ be an $2M_0$ -maximal separating set of $\text{Int}_{M_0}(\mathcal{B}_{h^-+kR}^X)$. Then:

1. For all $x, x' \in \mathcal{D}_k(\mathcal{B}^X)$ with $x \neq x'$ we have $D_{M_0}(x) \cap D_{M_0}(x') = \emptyset$.
2. $\text{Int}_{M_0}(\mathcal{B}_{h^-+kR}^X) \subset \bigcup_{x \in \mathcal{D}_k(\mathcal{B}^X)} D_{2M_0}(x)$

Furthermore $\mathcal{N}_{M_0}(\text{Int}_{M_0}(\mathcal{B}_{h^-+kR}^X)) \subset \mathcal{B}_{h^-+kR}^X$, and for all $x \in \text{Int}_{M_0}(\mathcal{B}_{h^-+kR}^X)$ we have $D_{M_0}(x) \subset \mathcal{B}_{h^-+kR}^X$. Therefore

$$\bigsqcup_{x \in \mathcal{D}_k(\mathcal{B}^X)} D_{M_0}(x) \subset \mathcal{B}_{h^-+kR}^X \subset \bigcup_{x \in \mathcal{D}_k(\mathcal{B}^X)} D_{3M_0}(x) \quad (8.5)$$

For all $x \in \mathcal{D}_k(\mathcal{B}^X)$, we define

$$\mathcal{C}(x) := \{p \in \mathcal{B}_{h^-+kR}^X \mid d(p, x) \leq d(p, x') \text{ for all } x' \in \mathcal{D}_k(\mathcal{B}^X)\}.$$

As discussed at the beginning of Section 8.2, these cells might intersect each other on their boundaries. However, a point contained in different cells can be removed in all of them except one, making them disjoint. The choice of cells on which we remove boundary points can be made thanks to an arbitrary order on the finite set $\mathcal{D}_k(\mathcal{B}^X)$.

By the inclusions (8.5), for all $x \in \mathcal{D}_k(\mathcal{B}^X)$ we have $D_{M_0}(x) \subset \mathcal{C}(x) \subset D_{3M_0}(x)$ and

$$\bigsqcup_{x \in \mathcal{D}_k(\mathcal{B}^X)} \mathcal{C}(x) = \mathcal{B}_{h^-+kR}^X.$$

Furthermore, since vertical geodesic rays are uniquely determined by their starting point (because X is Busemann), a tiling with cells provides us with a box tiling:

$$\bigsqcup_{x \in \mathcal{D}_k(\mathcal{B}^X)} \mathcal{B}^X(x, \mathcal{C}(x), R) = \bigcup_{z \in [h^- + (k-1)R; h^- + kR[} \mathcal{B}_z^X.$$

Taking the union on $k \in \{1, \dots, N\}$ provides us with the conclusion. \square

8.4 Box-tiling of $X \rtimes Y$

The boxes \mathcal{B} of a horospherical product $X \rtimes Y$ are constructed as the horospherical products of boxes $\mathcal{B}^X \rtimes \mathcal{B}^Y$. Therefore they induce a tiling of $X \rtimes Y$. Such boxes are illustrated by Figure 8.4.

Definition 8.4.1. (Box of $X \rtimes Y$ at scale R)

Let X and Y be two admissible spaces. A set $\mathcal{B} \subset X \rtimes Y$ is called box at scale R of $X \rtimes Y$ if there exists \mathcal{B}^X a box at scale R of X and \mathcal{B}^Y a box at scale R of Y such that:

1. $h^-(\mathcal{B}^X) = -h^+(\mathcal{B}^Y)$
2. $\mathcal{B} := \mathcal{B}^X \rtimes \mathcal{B}^Y = \{(x, y) \in \mathcal{B}^X \times \mathcal{B}^Y \mid h_X(x) = -h_Y(y)\}$

Let us point out that in the last definition, the box of Y is in fact defined by

$$\mathcal{B}^Y(y, R) := \bigcup_{z \in]-nR; (1-n)R]} \pi_z(\mathcal{C}(y)). \quad (8.6)$$

This choice on the boundaries of the height intervals allows a precise match for the height inside the two boxes. Furthermore, one can see that given a box-tiling of X and a box-tiling of Y , the natural subsequent tiling on $X \times Y$ provides the box tiling of $X \rtimes Y$ by restriction.

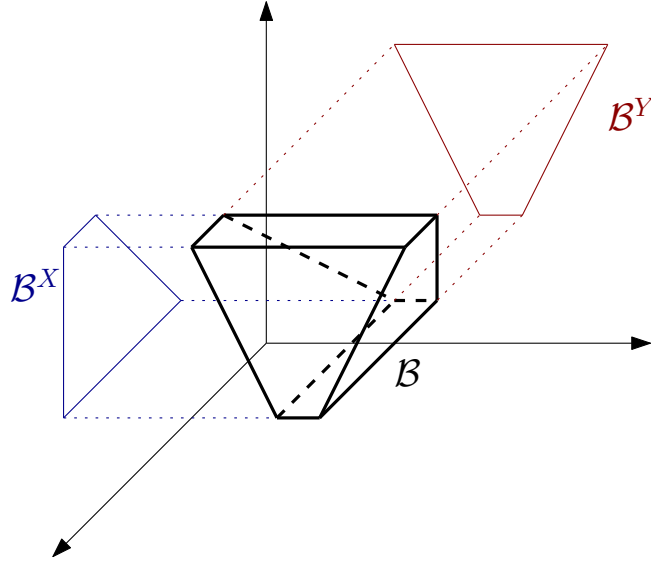
Figure 8.4: Box in $X \rtimes Y$ **Proposition 8.4.2.** (Box-tiling of $X \rtimes Y$ at scale R)

Let X and Y be two admissible spaces. Let R be a positive number and let us consider the two following box tilings of X and Y :

$$X = \bigsqcup_{n \in \mathbb{Z}} \bigsqcup_{x \in \mathcal{D}(X_{nR})} \mathcal{B}^X(x, R)$$

$$Y = \bigsqcup_{n \in \mathbb{Z}} \bigsqcup_{y \in \mathcal{D}(Y_{nR})} \mathcal{B}^Y(y, R)$$

Then the boxes of $X \rtimes Y$ constructed from boxes at opposite height in X and Y are a box tiling of $X \rtimes Y$. We have

$$X \rtimes Y = \bigsqcup_{n \in \mathbb{Z}} \bigsqcup_{(x,y) \in \mathcal{D}(X_{nR}) \times \mathcal{D}(Y_{(1-n)R})} \mathcal{B}^X(x, R) \rtimes \mathcal{B}^Y(y, R)$$

Proof. Let us consider the box tilings of X and Y :

$$X = \bigsqcup_{n \in \mathbb{Z}} \bigsqcup_{x \in \mathcal{D}(X_{nR})} \mathcal{B}^X(x, R)$$

$$Y = \bigsqcup_{n \in \mathbb{Z}} \bigsqcup_{y \in \mathcal{D}(Y_{nR})} \mathcal{B}^Y(y, R)$$

We first show that the intersection of two distinct boxes is empty. Let $n_1, n_2 \in \mathbb{R}$, $x_1 \in \mathcal{D}(X_{n_1R})$, $x_2 \in \mathcal{D}(X_{n_2R})$, $y_1 \in \mathcal{D}(Y_{(1-n_1)R})$ and $y_2 \in \mathcal{D}(Y_{(1-n_2)R})$ such that $(x_1, y_1) \neq (x_2, y_2)$. Then we have either $x_1 \neq x_2$ or $y_1 \neq y_2$. Let us consider the case $x_1 \neq x_2$, then $\mathcal{B}^X(x_1, R) \neq \mathcal{B}^X(x_2, R)$, and since they are two tiles of the box tiling of X , we have $\mathcal{B}^X(x_1, R) \cap \mathcal{B}^X(x_2, R) = \emptyset$. Therefore

$$\forall (p_1^X, p_1^Y) \in \mathcal{B}^X(x_1, R) \rtimes \mathcal{B}^Y(y_1, R), \forall (p_2^X, p_2^Y) \in \mathcal{B}^X(x_2, R) \rtimes \mathcal{B}^Y(y_2, R) \text{ we have } p_1^X \neq p_2^X$$

Hence $(p_1^X, p_1^Y) \neq (p_2^X, p_2^Y)$, which gives us

$$(\mathcal{B}^X(x_1, R) \rtimes \mathcal{B}^Y(y_1, R)) \cap (\mathcal{B}^X(x_2, R) \rtimes \mathcal{B}^Y(y_2, R)) = \emptyset.$$

The case when $y_1 \neq y_2$ provide us with the same conclusion. Then we prove that the whole space $X \rtimes Y$ is covered by the horospherical product of boxes. Let $p = (p^X, p^Y) \in X \rtimes Y$. There exists $n \in \mathbb{Z}$ such that $(n-1)R \leq h(p) < nR$, hence there exist $x \in \mathcal{D}(X_{nR})$ and $y \in \mathcal{D}(Y_{(1-n)R})$ such that $p^X \in \mathcal{B}^X(x, R)$ and $p^Y \in \mathcal{B}^Y(y, R)$. Therefore $p \in \mathcal{B}^X(x, R) \rtimes \mathcal{B}^Y(y, R)$. \square

8.5 Measure of balls, boxes and neighbourhoods

The results of this sections focus on estimates on the measure μ of balls and boxes.

Lemma 8.5.1. *There exists $M(\varkappa)$ such that for all $r \geq M$ and all box \mathcal{B} at scale r of $X \varkappa Y$ we have*

$$\mu(\mathcal{B}) \lesssim_{\varkappa} e^{mr} \quad (8.7)$$

Proof. Without loss of generality we can assume that $h(\mathcal{B}) = [0; r[$. Let us denote by \mathcal{C}^X the cell of \mathcal{B}^X and \mathcal{C}^Y the cell of \mathcal{B}^Y . Then

$$\begin{aligned} \mu(\mathcal{B}) &= \int_0^r \mu_z(\mathcal{B}_z) dz = \int_0^r \mu_z^X(\mathcal{B}_z^X) \mu_z^Y(\mathcal{B}_z^Y) dz, \quad \text{since } \mathcal{B}_z = \mathcal{B}_z^X \times \mathcal{B}_z^Y \\ &\lesssim_{\varkappa} \int_0^r e^{m(r-z)} \mu_r^X(\mathcal{C}^X) e^{nz} \mu_0^Y(\mathcal{C}^Y) dz, \quad \text{by assumption (E3) and definition of boxes,} \\ &\lesssim_{\varkappa} e^{mr} \int_0^r e^{(n-m)z} dz, \quad \text{by Lemma 8.1.2,} \\ &= \frac{e^{mr} - e^{nr}}{m-n} \leq_{\varkappa} e^{mr} \end{aligned}$$

However $m > n$, hence for $r \geq \frac{1}{m-n}$ we have $\frac{1}{2}e^{mr} \geq e^{nr}$. Therefore

$$\frac{e^{mr} - e^{nr}}{m-n} \geq \frac{e^{mr}}{2(m-n)} \geq_{\varkappa} e^{mr}$$

□

Combining Lemmas 8.2.2 and 8.5.1 we get the next corollary.

Corollary 8.5.2. *There exists $M(\varkappa)$ such that for any $r \geq M$ and any $p \in X \varkappa Y$ we have*

$$e^{\frac{m}{2}r} \leq_{\varkappa} \mu(B(p, r)) \leq_{\varkappa} e^{3mr} \quad (8.8)$$

Therefore we have the following estimate between ball measures.

Corollary 8.5.3. *There exists $M(\varkappa)$ such that for any $r_2 > r_1 \geq M$ and for all $p_1, p_2 \in X \varkappa Y$*

$$\exp\left(\frac{1}{6}|r_2 - r_1|m\right) \mu(B(p_1, r_1)) \leq \mu(B(p_2, r_2)) \leq \exp(6|r_2 - r_1|m) \mu(B(p_1, r_1))$$

Corollary 8.5.4. *There exists $M(\varkappa)$ such that for any $r_2 > r_1 \geq M$ and for all $A \subset X \varkappa Y$*

$$\mu(\mathcal{N}_{r_2}(A)) \leq_{\varkappa} e^{6|r_2 - r_1|m} \mu(\mathcal{N}_{r_1}(A))$$

Furthermore, if there exists $z \in \mathbb{R}$ such that $A \subset X_z$ we have

$$\mu(\mathcal{N}_M(A)) \lesssim_{\varkappa} \mu_z(\mathcal{N}_M(A) \cap X_z)$$

In particular, for all $p \in (X \varkappa Y)_z$

$$\mu(B(p, M)) \lesssim_{\varkappa} \mu_z(D_M(p))$$

Proof. Since $X \varkappa Y$ is a proper metric space, by a covering lemma of [19 Heinenen], there exists a set $Z \subset A$ such that:

1. The balls $B(p, r_1)$ for $p \in Z$ are pairwise disjoint.

2. We have the following inclusions:

$$\bigsqcup_{p \in Z} B(p, r_1) \subset \mathcal{N}_{r_1}(A) \subset \bigcup_{p \in Z} B(p, 5r_1)$$

Therefore $\mathcal{N}_{r_2}(A) \subset \bigcup_{p \in Z} B(p, 5r_1 + (r_2 - r_1))$.

Moreover, if $A \subset X_z$, for $r_1 = M$ we have

$$\bigsqcup_{p \in Z} D_M(p) \subset \mathcal{N}_M(A) \cap X_z \subset \bigcup_{p \in Z} D_{5M}(p),$$

and for all $p \in Z$, $\mu_z(B(p, 5M)) \simeq_{\mathfrak{M}} 1 \simeq_{\mathfrak{M}} \mu_z(D_{5M}(p))$. Hence

$$\begin{aligned} \mu(\mathcal{N}_M(A)) &\simeq_{\mathfrak{M}} \sum_{p \in Z} \mu(B(p, 5M)) \\ &\simeq_{\mathfrak{M}} \sum_{p \in Z} \mu_z(D_{5M}(p)) \simeq_{\mathfrak{M}} \mu_z(\mathcal{N}_M(A) \cap X_z) \end{aligned}$$

□

A (k, c) -quasi-isometry $\Phi : X \rtimes Y \rightarrow X \rtimes Y$ "quasi"-preserve the measure μ .

Lemma 8.5.5. For all (k, c) -quasi-isometry $\Phi : X \rtimes Y \rightarrow X \rtimes Y$ and for all measurable subset $U \subset X \rtimes Y$ we have

$$\mu(\mathcal{N}_{k(c+1)}(U)) \simeq_{k,c,\mathfrak{M}} \mu(\mathcal{N}_1(\Phi(U)))$$

Proof. Since $X \rtimes Y$ is a proper metric space, by a classical covering lemma of [19, Heinonen] there exists a set $Z \subset U$ such that:

1. The balls $B(p, k(c+1))$ for $p \in Z$ are pairwise disjoint.
2. We have the following inclusions:

$$\bigsqcup_{p \in Z} B(p, k(c+1)) \subset \mathcal{N}_{k(c+1)}(U) \subset \bigcup_{p \in Z} B(p, 5k(c+1))$$

Since Φ is a (k, c) -quasi-isometry, $\Phi(Z)$ verifies:

1. The balls $B(q, 1)$ for $q \in \Phi(Z)$ are pairwise disjoint.
2. We have the following inclusions:

$$\bigsqcup_{q \in \Phi(Z)} B(q, 1) \subset \mathcal{N}_1(\Phi(U)) \subset \bigcup_{q \in \Phi(Z)} B(q, 5k^2(c+1) + c)$$

Using Corollary 8.5.3 on each ball of Z and $\Phi(Z)$ provides us with the wanted inequalities. □

8.6 Set of vertical geodesics

We defined in 2.2.4 a notion of vertical geodesics on the hyperbolic space X . For x a point of X , there exists a unique vertical geodesic ray starting from x in X , therefore, there is a one to one correspondence between portions of vertical geodesic rays in a box \mathcal{B}^X , and the points at the bottom of \mathcal{B}^X . A vertical geodesic segment of \mathcal{B}^X is defined as the intersection of a vertical geodesic and \mathcal{B}^X . We recall that vertical geodesics are parametrised by arclength by their height.

Let \mathcal{B}^X be a box at scale R of X . Let us denote by $V\mathcal{B}^X$ the set of vertical geodesic segments of \mathcal{B}^X . A geodesic segment $v \in V\mathcal{B}^X$ intersects only in one point x the bottom of \mathcal{B}^X , and v is the only vertical geodesic segment of $V\mathcal{B}^X$ intersecting x by the Busemann assumption on X .

Definition 8.6.1. (Measure η on $V\mathcal{B}^X$)

Let \mathcal{B}^X be a box at scale R of X . The measure $\eta_{V\mathcal{B}^X}^X$ on $V\mathcal{B}^X$ is defined on all measurable subset $U \subset V\mathcal{B}^X$ by

$$\eta_{V\mathcal{B}^X}^X(U) = \lambda_{h^-(\mathcal{B}^X)}^X(\{\gamma(h^-(\mathcal{B}^X)) \mid \gamma \in U\}) \quad (8.9)$$

In particular, we say that U is measurable if $\{\gamma(h^-(\mathcal{B}^X)) \mid \gamma \in U\}$ is measurable. Since the measure λ is almost constant along projections, the measure on the set of vertical geodesic segment is related to the height of the boxes. Specifically we show that up to a multiplicative constant, the measure of a box is equal to the measure of its set of vertical geodesic segments multiplied by its height, as for rectangles in \mathbb{R}^2 . In the sequel we might omit the index of the measure η^X .

Property 8.6.2. Let \mathcal{B}^X be a box at scale R of X and let us denote $h^- := h^-(\mathcal{B}^X)$ and $h^+ := h^+(\mathcal{B}^X)$. We have for all $z \in [h^-, h^+]$:

1. $\eta^X(V\mathcal{B}^X) \simeq_X \lambda_z^X(\mathcal{B}_z^X) \simeq_X e^{mh^+}$
2. $\lambda^X(\mathcal{B}^X) \simeq_X R\lambda_z^X(\mathcal{B}_z^X) \simeq_X R\eta^X(V\mathcal{B}^X) \simeq_X Re^{mh^+}$

Proof. Let $x \in X$ be such that $\mathcal{C}(x)$ is the cell of \mathcal{B}^X . We know that $D_{M_0}(x) \subset \mathcal{C}(x) \subset D_{2M_0}(x)$, hence by Lemma 8.1.2 we have

$$\mu_{h(x)}^X(\mathcal{C}(x)) \simeq_X 1 \quad (8.10)$$

Then

$$\begin{aligned} \eta^X(V\mathcal{B}^X) &= \lambda_{h^-}^X(\mathcal{B}^X \cap h^{-1}(h^-)), \quad \text{by definition,} \\ &\simeq_X \lambda_z^X(\mathcal{B}_z^X) \simeq_X \lambda_{h^+}^X(\mathcal{C}(x)) \simeq_X e^{mh^+} \mu_{h^+}^X(\mathcal{C}(x)), \quad \text{by Property 8.1.5} \\ &\simeq_X e^{mh^+}, \end{aligned}$$

which proves the first point. The second point follows from the fact that the measures λ_z are constant by projections on height level sets, up to the multiplicative constant $M(X)$.

$$\begin{aligned} \lambda^X(\mathcal{B}^X) &= \int_{h^-}^{h^+} \lambda_z^X(\mathcal{B}^X \cap h^{-1}(z)) dz = \int_{h^-}^{h^+} \lambda_z^X(\pi_z(\mathcal{C}(x))) dz \\ &\simeq_X \int_{h^-}^{h^+} \lambda_{h^+}^X(\mathcal{C}(x)) dz, \quad \text{by Property 8.1.5,} \\ &\simeq_X R\lambda_{h^+}^X(\mathcal{C}(x)) \simeq_X Re^{mh^+} \end{aligned}$$

□

A vertical geodesic $V = (V^X, V^Y) \subset X \bowtie Y$ is a couple of vertical geodesics of X and Y . Therefore, there is a bijection between the set of vertical geodesic segments $V\mathcal{B}$ of a box $\mathcal{B} := \mathcal{B}^X \bowtie \mathcal{B}^Y$ and $V\mathcal{B}^X \times V\mathcal{B}^Y$.

Definition 8.6.3. Let \mathcal{B} be a box at scale R of $X \bowtie Y$. We define the measure $\eta_{V\mathcal{B}}$ on $V\mathcal{B}$ as

$$\eta_{V\mathcal{B}} := \eta_{V\mathcal{B}^X}^X \otimes \eta_{V\mathcal{B}^Y}^Y \quad (8.11)$$

In the notation of measures on sets of vertical geodesic segments, we might omit the reference to the corresponding sets. The measures $\eta_{V\mathcal{B}}$, respectively $\eta_{V\mathcal{B}^X}^X$, $\eta_{V\mathcal{B}^Y}^Y$, will simply be denoted by η , respectively η^X , η^Y .

Property 8.6.4. For each box \mathcal{B} at scale R of $X \rtimes Y$ we have for all $z_1, z_2 \in [h^-, h^+]$:

1. $\eta(V\mathcal{B}) \simeq_{\rtimes} e^{mh^+} e^{-nh^-} \simeq_{\rtimes} \lambda_{z_1}^X(\mathcal{B}_{z_1}^X) \lambda_{-z_2}^Y(\mathcal{B}_{-z_2}^Y)$
2. $\lambda(\mathcal{B}) \simeq_{\rtimes} R\eta(V\mathcal{B}) \simeq_{\rtimes} R\lambda_{z_1}^X(\mathcal{B}_{z_1}^X) \lambda_{-z_2}^Y(\mathcal{B}_{-z_2}^Y)$

Proof. The first point follows from definition 8.6.3 and Property 8.6.2 applied on \mathcal{B}^X and \mathcal{B}^Y . The proof of the second point is similar to the proof of Property 8.6.2

$$\begin{aligned} \lambda(\mathcal{B}) &= \int_{h^-}^{h^+} \lambda_z^X \otimes \lambda_{-z}^Y(\mathcal{B}_z^X \times \mathcal{B}_{-z}^Y) dz = \int_{h^-}^{h^+} \lambda_z^X(\mathcal{B}_z^X) \lambda_{-z}^Y(\mathcal{B}_{-z}^Y) dz \\ &\simeq_{\rtimes} \int_{h^-}^{h^+} \lambda_{h^-}^X(\mathcal{B}_{h^-}^X) \lambda_{-h^+}^Y(\mathcal{B}_{-h^+}^Y) dz, \quad \text{by Property 8.1.5,} \\ &\simeq_{\rtimes} \int_{h^-}^{h^+} \eta^X(V\mathcal{B}^X) \eta^Y(V\mathcal{B}^Y) dz, \quad \text{by definition of } \eta, \\ &\simeq_{\rtimes} \eta(V\mathcal{B}) \int_{h^-}^{h^+} 1 dz = R\eta(V\mathcal{B}) \end{aligned}$$

Then applying twice Property 8.6.2 provides us with the result. \square

Let \mathcal{B} be a box at scale R . Let $z \in [h^-(\mathcal{B}); h^+(\mathcal{B})[$ and let $U \subset \mathcal{B}_z$. Then we denote $V_{\mathcal{B}}(U)$ the set of vertical geodesic segments of $V\mathcal{B}$ intersecting U , it is in bijection with

$$\{(x, y) \in \mathcal{B}_0^X \times \mathcal{B}_{-R}^Y \mid (\pi_z^X(x), \pi_{-z}^Y(y)) \in U\}$$

We need the following property stating that the measure of a given subfamily of vertical geodesics can be computed on any level of our box.

Property 8.6.5. Let \mathcal{B} be a box at scale R of $X \rtimes Y$. Then for all $z \in [h^-(\mathcal{B}); h^+(\mathcal{B})[$ and for all measurable subset $U_z \subset \mathcal{B}_z$

$$\eta(V_{\mathcal{B}}(U_z)) \simeq_{\rtimes} \lambda_z(U_z)$$

Proof. Without loss of generality we can assume that $[h^-(\mathcal{B}); h^+(\mathcal{B})[= [0 : R[$. By definition we have

$$\begin{aligned} \eta(V_{\mathcal{B}}(U_z)) &:= \int_{x_0 \in \mathcal{B}_0^X} \int_{y_0 \in \mathcal{B}_{-R}^Y} \mathbb{1}_{\{(x,y) \in \mathcal{B}_0^X \times \mathcal{B}_{-R}^Y \mid (\pi_z^X(x), \pi_{-z}^Y(y)) \in U_z\}}(x_0, y_0) d\lambda_{-R}^Y d\lambda_0^X \\ &= \int_{x_0 \in \mathcal{B}_0^X} \int_{y_0 \in \mathcal{B}_{-R}^Y} \mathbb{1}_{U_z}(\pi_z^X(x_0), \pi_{-z}^Y(y_0)) d\lambda_{-R}^Y d\lambda_0^X \\ &= \int_{x_0 \in \mathcal{B}_0^X} \left(\int_{y \in \mathcal{B}_{-z}^Y} \mathbb{1}_{U_z}(\pi_z^X(x_0), y) d(\pi_{-z}^Y * \lambda_{-R}^Y) \right) d\lambda_0^X, \quad \text{with a pushforward of } \lambda_{-R}^Y \text{ by } \pi_{-z}^Y, \\ &= \int_{y \in \mathcal{B}_{-z}^Y} \left(\int_{x_0 \in \mathcal{B}_0^X} \mathbb{1}_{U_z}(\pi_z^X(x_0), y) d\lambda_0^X \right) d(\pi_{-z}^Y * \lambda_{-R}^Y), \quad \text{by Fubini's Theorem,} \\ &= \int_{y \in \mathcal{B}_{-z}^Y} \left(\int_{x \in \mathcal{B}_z^X} \mathbb{1}_{U_z}(x, y) d(\pi_z^X * \lambda_0^X) \right) d(\pi_{-z}^Y * \lambda_{-R}^Y), \quad \text{with a pushforward of } \lambda_0^X \text{ by } \pi_z^X, \\ &\simeq_{\rtimes} \int_{y \in \mathcal{B}_{-z}^Y} \int_{x \in \mathcal{B}_z^X} \mathbb{1}_{U_z}(x, y) d\lambda_z^X d\lambda_{-z}^Y, \quad \text{by using Property 8.1.5 twice,} \\ &\simeq_{\rtimes} \lambda_z(U_z). \end{aligned}$$

□

8.7 Projections of set of almost full measure

Let us denote by $p^X : X \times Y \rightarrow X ; (x, y) \mapsto x$ and by $p^Y : X \times Y \rightarrow Y ; (x, y) \mapsto y$ the projections on the two coordinates of $X \times Y$. We also denote by slight abuse the projection on a set of vertical geodesic segments $p^X : V\mathcal{B} \rightarrow V\mathcal{B}^X ; (v^X, v^Y) \mapsto v^X$ and $p^Y : V\mathcal{B} \rightarrow V\mathcal{B}^Y ; (v^X, v^Y) \mapsto v^Y$. Given a subset $U \subset V\mathcal{B}$, we might simply denote by U^X , respectively U^Y , its projection on X , respectively on Y , and similarly for subsets of $V\mathcal{B}$.

In this section, we show that if a subset of a box has almost full measure, then most of the fibers with respect to these projections also have almost full measure.

Let $0 < \alpha \leq 1$, let $V_1 \subset V\mathcal{B}$ be a measurable subset. Let us denote for all $v^X \in V\mathcal{B}^X$

$$\begin{aligned} G^Y(v^X) &:= \{v^Y \in V\mathcal{B}^Y \mid (v^X, v^Y) \in V_1\} = (p^Y)^{-1}(p^X(v^X) \cap (V\mathcal{B} \setminus V_1)) \\ G^X &:= \{v^X \in V\mathcal{B}^X \mid \eta^Y(G^Y(v^X)) \geq (1 - \sqrt{\alpha})\eta^Y(V_1^Y)\} \end{aligned}$$

The set G^X is the set of vertical geodesics in $V\mathcal{B}^X$ whose fibers have almost full intersection with $V\mathcal{B} \setminus V_1$.

The following lemma asserts that almost all fibers have almost full intersection with $V\mathcal{B} \setminus V_1$.

Lemma 8.7.1. *Let $0 < \alpha \leq 1$ and let $V_1 \subset V\mathcal{B}$ be a measurable subset such that $\eta(V_1) \leq \alpha\eta(V\mathcal{B})$, then*

$$\eta^X(G^X) \geq (1 - \sqrt{\alpha})\eta^X(V\mathcal{B}^X)$$

Proof. By construction we have

$$\bigcup_{v^X \in V\mathcal{B}^X} G^Y(v^X) = (V\mathcal{B} \setminus V_1)^Y$$

To prove the Lemma we proceed by contradiction. Let us assume that $\eta^X(G^X) < (1 - \sqrt{\alpha})\eta^X(V\mathcal{B}^X)$, then $\eta^X(V\mathcal{B}^X \setminus G^X) > \sqrt{\alpha}\eta^X(V\mathcal{B}^X)$. Therefore

$$\begin{aligned} \eta(V_1) &= \int_{V\mathcal{B}} \mathbb{1}_{V_1}(v) d\eta(v) \\ &= \int_{V\mathcal{B}^X} \int_{V\mathcal{B}^Y} \mathbb{1}_{V_1}(v^X, v^Y) d\eta^Y(v^Y) d\eta^X(v^X), \quad \text{by definition of } \eta, \\ &= \int_{V\mathcal{B}^X} \int_{V\mathcal{B}^Y} \mathbb{1}_{V\mathcal{B}^Y \setminus G^Y(v^X)}(v^Y) d\eta^Y(v^Y) d\eta^X(v^X), \quad \text{by definition of } G^Y(v^X), \\ &= \int_{V\mathcal{B}^X} \eta^Y(V\mathcal{B}^Y \setminus G^Y(v^X)) d\eta^X(v^X) \geq \int_{V\mathcal{B}^X \setminus G^X} \eta^Y(V\mathcal{B}^Y \setminus G^Y(v^X)) d\eta^X(v^X) \end{aligned}$$

Furthermore, when $v^X \in V\mathcal{B}^X \setminus G^X$ we have that $\eta^Y(G^Y(v^X)) < (1 - \sqrt{\alpha})\eta^Y(V\mathcal{B}^Y)$, hence $\eta^Y(V\mathcal{B}^Y \setminus G^Y(v^X)) \geq \sqrt{\alpha}\eta^Y(V\mathcal{B}^Y)$. Therefore

$$\begin{aligned} \eta(V_1) &\geq \int_{V\mathcal{B}^X \setminus G^X} \sqrt{\alpha}\eta^Y(V\mathcal{B}^Y) d\eta^X(v^X) \\ &\geq \sqrt{\alpha}\eta^Y(V\mathcal{B}^Y)\eta^X(V\mathcal{B}^X \setminus G^X) \\ &\geq \sqrt{\alpha}\sqrt{\alpha}\eta^Y(V\mathcal{B}^Y)\eta^X(V\mathcal{B}^X), \quad \text{by the contradiction assumption,} \\ &> \alpha\eta(V\mathcal{B}), \quad \text{, since } V\mathcal{B} \text{ is a product,} \end{aligned}$$

which contradicts $\eta(V_1) \leq \alpha\eta(V\mathcal{B})$. □

In the previous Lemma we only used the fact that the set of vertical geodesic segments $V\mathcal{B}$ was the product of its projections endowed with a product measure η . We will use it once on the product of two measured spaces endowed with a product measure in the proof of Proposition [9.3.1](#).

We recall that for any $U \subset X \times Y$ we denote $V\mathcal{B}(U) := \{v \in V\mathcal{B} \mid \text{im}(v) \cap U \neq \emptyset\}$. Similarly for all $V_1 \subset V\mathcal{B}$ we denote $V_1(U) := \{v \in V_1 \mid \text{im}(v) \cap U \neq \emptyset\}$.

The next Lemma is a local version of Lemma [8.7.1](#). Let $V_1 \subset V\mathcal{B}$. Let $M > 0$ be a constant, let $a \in \mathcal{B}$ and let us denote $VD := V\mathcal{B}(D_M(a))$ and $V_1D := V_1(D_M(a))$. For all $v = (v^X, v^Y) \in V\mathcal{B}$, let us denote by

$$\begin{aligned} E^Y(v^X) &:= \{v^Y \in VD^Y \mid (v^X, v^Y) \in V_1D\} = (p^Y)^{-1}(p^X(v^X) \cap (VD \setminus V_1D)) \\ F^X &:= \{v^X \in VD^X \mid \eta^Y(E^Y(v^X)) \geq \sqrt{\alpha}\eta^Y(VD^Y)\}. \end{aligned}$$

Lemma 8.7.2. *Let $0 < \alpha \leq 1$. If $\eta(V_1D) \leq \alpha\eta(VD)$ then*

$$\eta^X(F^X) \leq \sqrt{\alpha}\eta^X(VD^X) \quad (8.12)$$

Proof. Let us proceed by contradiction. We assume that

$$\eta^X(F_i^X) > \sqrt{\alpha}\eta^X(VD_i^X) \quad (8.13)$$

Then we have

$$\begin{aligned} \eta(V_1D) &= \int_{v^X \in VD^X} \int_{v^Y \in VD^Y} \mathbb{1}_{V_1D}(v^X, v^Y) d\eta^Y d\eta^X \\ &= \int_{v^X \in VD^X} \int_{v^Y \in VD^Y} \mathbb{1}_{E^Y(v^X)}(v^Y) d\eta^Y d\eta^X \\ &= \int_{v^X \in VD^X} \eta^Y(E^Y(v^X)) d\eta^X, \quad \text{by the definition of } E^Y(v^X), \\ &\geq \int_{v^X \in F^X} \eta^Y(E^Y(v^X)) d\eta^X, \quad \text{since } F^X \subset VD^X, \\ &> \sqrt{\alpha}\eta^X(VD^X) \sqrt{\alpha}\eta^Y(VD^Y) > \alpha\eta(VD), \end{aligned}$$

which contradicts assumption on VD . Hence $\eta^X(F^X) \leq \sqrt{\alpha}\eta^X(VD^X)$. \square

The following lemma asserts that for almost all points of the box, almost all vertical geodesics passing through the disc $D_{M_0}(x)$ do not belong to V_1 .

Lemma 8.7.3. *There exists a constant $0 < \alpha(\aleph) \leq 1$ such that for all $0 < \alpha \leq \alpha(\aleph)$ the following statement holds. Let M_0 be the constant involved in assumption (E2) and let \mathcal{B} be a box at scale R . If there exists $V_1 \subset V\mathcal{B}$ such that $\eta(V_1) \leq \alpha\eta(V\mathcal{B})$. Then*

$$\lambda\left(\left\{x \in \mathcal{B} \mid \frac{\eta(V_1(D_{M_0}(x)))}{\eta(V\mathcal{B}(D_{M_0}(x)))} > \alpha^{\frac{1}{4}}\right\}\right) \leq \alpha^{\frac{1}{4}}\lambda(\mathcal{B}) \quad (8.14)$$

Proof. Without loss of generality we may assume that $h(\mathcal{B}) = [0; R[$. Let us denote

$$U = \left\{x \in \mathcal{B} \mid \frac{\eta(V_1(D_{M_0}(x)))}{\eta(V\mathcal{B}(D_{M_0}(x)))} > \alpha^{\frac{1}{4}}\right\} \quad (8.15)$$

We proceed by contradiction, let us assume that $\lambda(U) > \alpha^{\frac{1}{4}}\lambda(\mathcal{B})$. In this case there exists $z \in [0; R[$ such that $\lambda_z(U_z) > \alpha^{\frac{1}{4}}\lambda_z(\mathcal{B}_z)$. Let $U'_z \subset U_z$ be a $2M_0$ maximal separating set of U_z . We have that $\bigsqcup_{x \in U'_z} D_{M_0}(x)$ is a disjoint union and that $U_z \subset \bigcup_{x \in U'_z} D_{2M_0}(x)$. Then we have

$$\begin{aligned} \lambda_z \left(\bigsqcup_{x \in U'_z} D_{M_0}(x) \right) &= \sum_{x \in U'_z} \lambda_z(D_{M_0}(x)) = \sum_{x \in U'_z} \lambda_z(D_{2M_0}(x)) \frac{\lambda_z(D_{M_0}(x))}{\lambda_z(D_{2M_0}(x))} \\ &\stackrel{\approx_{\aleph}}{\sim} \sum_{x \in U'_z} \lambda_z(D_{2M_0}(x)), \quad \text{by Lemma \ref{8.1.2}} \\ &\geq \lambda_z \left(\bigcup_{x \in U'_z} D_{2M_0}(x) \right) \geq \lambda_z(U_z) \\ &\geq_{\aleph} \alpha^{\frac{1}{4}}\lambda_z(\mathcal{B}), \quad \text{by assumption on } U_z. \end{aligned} \tag{8.16}$$

However $\forall x \in U'_z$ we have $\eta(V_1(D_{M_0}(x))) > \alpha^{\frac{1}{4}}\eta(V\mathcal{B}(D_{M_0}(x)))$, therefore

$$\begin{aligned} \eta \left(V_1 \left(\bigcup_{x \in U'_z} D_{M_0}(x) \right) \right) &> \alpha^{\frac{1}{4}}\eta \left(V\mathcal{B} \left(\bigcup_{x \in U'_z} D_{M_0}(x) \right) \right) \\ &\stackrel{\approx_{\aleph}}{\sim} \alpha^{\frac{1}{4}}\lambda_z \left(\bigcup_{x \in U'_z} D_{M_0}(x) \right), \quad \text{by Lemma \ref{8.6.5}} \\ &\geq \alpha^{\frac{1}{4}}\alpha^{\frac{1}{4}}\lambda_z(\mathcal{B}) = \sqrt{\alpha}\lambda_z(\mathcal{B}), \quad \text{by inequality \ref{8.16}} \\ &\stackrel{\approx_{\aleph}}{\sim} \sqrt{\alpha}\eta(V\mathcal{B}), \quad \text{by Lemma \ref{8.6.5}} \end{aligned}$$

Since $\eta(V_1) \geq \eta \left(V_1 \left(\bigcup_{x \in U'_z} D_{M_0}(x) \right) \right)$ and since $\sqrt{\alpha} > M(\aleph)\alpha$ for $\alpha < \frac{1}{M^2}$, it contradicts the assumptions of the lemma. \square

Let us point out that in this Lemma, we first showed that on a fixed level-set, most of its point were surrounded by almost only of vertical geodesic not in V_1 . This remark will be relevant in the proof of Proposition [9.3.1](#).

The three next lemmas are estimates on the quantity of Y -horospheres verifying specific properties. They are used in section [9.4](#). Let \mathcal{B} be a box, $x \in \mathcal{B}$ let $U \subset \mathcal{B}$ and let us denote by

$$H_x := \{x\} \rtimes \mathcal{B}^Y = \{(x, y) \mid y \in \mathcal{B}^Y, h(y) = -h(x)\} = (p^X)^{-1}(x),$$

a Y -horosphere of \mathcal{B} . Let us denote by

$$\begin{aligned} E^Y(x) &:= \{y \in \mathcal{B}^Y \mid (x, y) \in U^c\} = p^Y(p^{X-1}(x) \cap U^c) = (H_x \cap U^c)^Y \\ E^X &:= \left\{ x \in \mathcal{B}^X \mid \lambda_{-h(x)}^Y(E^Y(x)) > \sqrt{\alpha}\lambda^Y(H_x^Y) \text{ and } h(x) \geq h^-(\mathcal{B}^X) + \frac{R}{2} \right\} \end{aligned}$$

The set E^X is in bijection with the "bad" Y -horospheres H above the middle of \mathcal{B} , the ones which have more than $\sqrt{\alpha}$ fraction of their measure λ^Y in U^c .

The following lemma asserts that almost all Y -horospheres in the upper half of the box have almost full measure.

Lemma 8.7.4. *If $\lambda(U) \geq (1 - \alpha)\lambda(\mathcal{B})$ with $0 < \alpha < 1$, then we have*

$$\lambda^X(E^X) < \sqrt{\alpha}\lambda^X(\mathcal{B}^X)$$

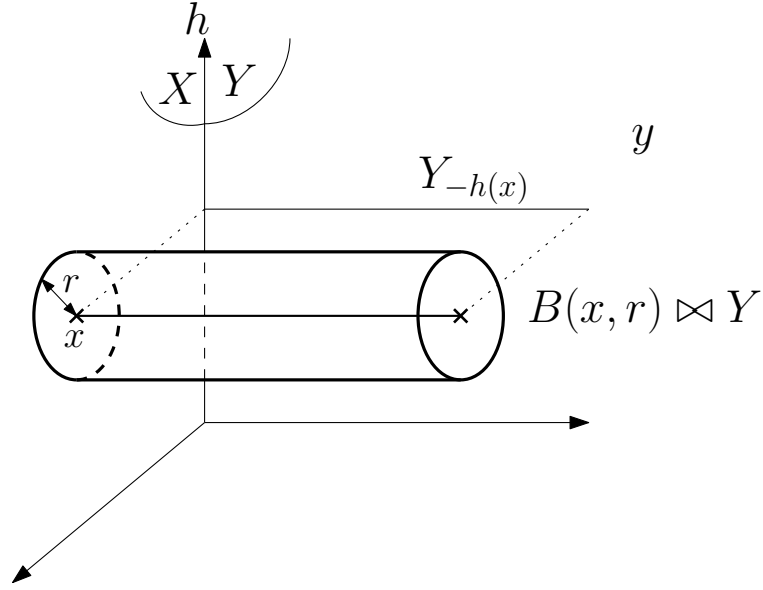
Figure 8.5: Large X -Horosphere in $X \rtimes Y$.

Proof. Without loss of generality we can assume that $h(\mathcal{B}) = [0; R[$. We proceed by contradiction, let us assume that $\lambda^X(E^X) \geq \sqrt{\alpha}\lambda^X(\mathcal{B}^X)$. Then we compute the measure of U^c :

$$\begin{aligned}
\lambda(U^c) &= \int_0^R \lambda_z^X \otimes \lambda_{-z}^Y(U_z^c) dz = \int_0^R \int_{\mathcal{B}_z^X} \lambda_{-z}^Y(\{y \in Y_{-z} \mid (x, y) \in U_z^c\}) d\lambda_z^X(x) dz, \quad \text{by definition,} \\
&= \int_0^R \int_{\mathcal{B}_z^X} \lambda_{-z}^Y((H_x \cap U^c)^Y) d\lambda_z^X(x) dz \\
&\geq \int_0^R \int_{E_z^X} \lambda_{-z}^Y((H_x \cap U^c)^Y) d\lambda_z^X(x) dz, \quad \text{since } E_z^X \subset \mathcal{B}_z^X, \\
&> \sqrt{\alpha} \int_0^R \left[\int_{E_z^X} \lambda_{-z}^Y(H_x^Y) d\lambda_z^X(x) \right] dz, \quad \text{by the definition of } E^X, \\
&= \sqrt{\alpha} \int_0^R [\lambda_{-z}^Y(\mathcal{B}_{-z}^Y) \lambda_z^X(E_z^X)] dz, \quad \text{by the definition of } H_x \\
&\geq \sqrt{\alpha}\sqrt{\alpha} \int_0^R \lambda_{-z}^Y(\mathcal{B}_{-z}^Y) \lambda_z^X(\mathcal{B}_z^X) dz \geq \alpha\lambda(\mathcal{B}), \quad \text{by assumption on } E^X,
\end{aligned}$$

which contradicts the assumption on U . □

For all $U \subset \mathcal{B}$ we denote $Sh(U)$ and call shadow of U the set of points of \mathcal{B} below U such that $Sh(U) := \{p \in \mathcal{B} \mid \exists V \in V\mathcal{B} \text{ containing } p \text{ and intersecting } U \text{ on a point } p' \text{ such that } h(p') \geq h(p)\}$.

For S a subset of X , we shall call *large Y -horosphere* the subset H_S defined by

$$H_S := S \rtimes Y = (p^X)^{-1}(S).$$

Let M_0 be the constant involved in assumption (E2). Let us denote by $F^X \subset \mathcal{B}^X$ the subset

$$F^X := \left\{ x \in \mathcal{B}^X \mid \lambda \left(\text{Sh}(H_{D_{M_0}(x)}) \cap U^c \right) > \alpha^{\frac{1}{4}} \lambda \left(\text{Sh}(H_{D_{M_0}(x)}) \right) \text{ and } h(x) \geq h^-(\mathcal{B}^X) + \frac{R}{2} \right\}$$

The set F^X is in bijection with the "bad" Y -horospheres H that are above the middle of the box \mathcal{B} . By "bad" we mean the ones which have more than $\alpha^{\frac{1}{4}}$ fraction of the measure λ of their shadow in U^c .

In the following lemma, we show that the shadow of almost all the Y -horospheres in the upper half of the box have almost full measure.

Lemma 8.7.5. *There exists a constant $0 < \alpha(\varkappa) \leq 1$ such that for all $0 < \alpha \leq \alpha(\varkappa)$ the following statement holds. If $\lambda(U) \geq (1 - \alpha) \lambda(\mathcal{B})$, then we have*

$$\lambda^X(F^X) < \alpha^{\frac{1}{4}} \lambda^X(\mathcal{B}^X)$$

Proof. Without loss of generality we can assume that $h(\mathcal{B}) = [0; R[$. We proceed by contradiction, let us assume that $\lambda^X(F^X) \geq \alpha^{\frac{1}{4}} \lambda^X(\mathcal{B}^X)$. Therefore, there exists $z_0 \in [\frac{R}{2}, R[$ such that

$$\lambda_{z_0}^X(F_{z_0}^X) \geq \alpha^{\frac{1}{4}} \lambda_{z_0}^X(\mathcal{B}_{z_0}^X).$$

Let Z be a $2M_0$ -maximal separating subset of $F_{z_0}^X$. Then we have

$$\begin{aligned} \lambda(U^c) &\geq \lambda \left(\text{Sh} \left(\bigsqcup_{x \in Z} H_{D_{M_0}(x)} \right) \cap U^c \right) = \sum_{x \in Z} \lambda \left(\text{Sh} \left(H_{D_{M_0}(x)} \right) \cap U^c \right), \quad \text{since this is a disjoint union,} \\ &\geq \alpha^{\frac{1}{4}} \sum_{x \in Z} \lambda \left(\text{Sh} \left(H_{D_{M_0}(x)} \right) \right) \underset{\varkappa}{\asymp} \alpha^{\frac{1}{4}} \sum_{x \in Z} z_0 \lambda_{z_0} \left(H_{D_{M_0}(x)} \right), \quad \text{by definition of } F_{z_0}^X \text{ and Proposition } \boxed{8.1.5}. \end{aligned}$$

However $\lambda_{z_0} \left(H_{D_{M_0}(x)} \right) = \lambda_{z_0}^X \left(D_{M_0}(x) \right) \lambda_{-z_0}^Y \left(\mathcal{B}_{-z_0}^Y \right)$ since $H_{D_{M_0}(x)} = D_{M_0}(x) \times \mathcal{B}_{-z_0}^Y$, hence

$$\begin{aligned} \lambda(U^c) &\geq \alpha^{\frac{1}{4}} z_0 \sum_{x \in Z} \lambda_{z_0}^X \left(D_{M_0}(x) \right) \lambda_{-z_0}^Y \left(\mathcal{B}_{-z_0}^Y \right) \\ &\underset{\varkappa}{\asymp} \alpha^{\frac{1}{4}} z_0 \lambda_{-z_0}^Y \left(\mathcal{B}_{-z_0}^Y \right) \sum_{x \in Z} \lambda_{z_0}^X \left(D_{2M_0}(x) \right), \quad \text{by Lemma } \boxed{8.1.2}, \\ &\geq \alpha^{\frac{1}{4}} z_0 \lambda_{-z_0}^Y \left(\mathcal{B}_{-z_0}^Y \right) \lambda_{z_0}^X \left(\bigcup_{x \in Z} D_{2M_0}(x) \right) \geq \alpha^{\frac{1}{4}} z_0 \lambda_{-z_0}^Y \left(\mathcal{B}_{-z_0}^Y \right) \lambda_{z_0}^X \left(F_{z_0}^X \right), \quad \text{by definition of } Z, \\ &\geq \alpha^{\frac{1}{4}} \alpha^{\frac{1}{4}} z_0 \lambda_{-z_0}^Y \left(\mathcal{B}_{-z_0}^Y \right) \lambda_{z_0}^X \left(\mathcal{B}_{z_0}^X \right), \quad \text{by assumption on } F_{z_0}^X, \\ &\geq \sqrt{\alpha} \frac{R}{2} \lambda_{-z_0}^Y \left(\mathcal{B}_{-z_0}^Y \right) \lambda_{z_0}^X \left(\mathcal{B}_{z_0}^X \right) \underset{\varkappa}{\asymp} \frac{1}{2} \sqrt{\alpha} \lambda(\mathcal{B}), \quad \text{since } z_0 \geq \frac{R}{2} \text{ and by Property } \boxed{8.6.4}, \end{aligned}$$

which contradicts the assumptions on U for $\alpha < \frac{1}{M(\varkappa)^2}$. \square

The following lemma asserts that the projection on a level-set of almost all the Y -horospheres have almost full measure.

Lemma 8.7.6. *If $\lambda(U) \geq (1 - \alpha) \lambda(\mathcal{B})$, then there exists a constant $M(\varkappa)$ such that for any large Y -horosphere $H_{D_{M_0}(x)}$ with $x \in \mathcal{B} \setminus F_X$ as in Lemma $\boxed{8.7.5}$, and for $1 \geq M\rho \geq M^2 \alpha^{\frac{1}{4}} > 0$, there exists P a level set of the height function in \mathcal{B} , such that*

$$\lambda_{h(P)}(P \cap \text{Sh}(H_{D_{M_0}(x)}) \cap U^c) \leq \varkappa \alpha^{\frac{1}{4}} \lambda_{h(P)}(P \cap \text{Sh}(H_{D_{M_0}(x)}))$$

Furthermore, P and H can be chosen such that $\rho R < d_{\varkappa}(P, H) < 2\rho R$.

Proof. We proceed by contradiction, let us assume that such a plan P does not exist, then computing the measure λ of $\text{Sh}(H_{D_{M_0}(x)}) \cap U^c \cap \mathcal{B}_{[h(H)-2\rho R; h(H)-\rho R]}$ contradicts the fact that $\lambda(\text{Sh}(H_{D_{M_0}(x)}) \cap U^c) \leq \alpha^{\frac{1}{4}}$ by Lemma $\boxed{8.1.5}$ and since we integrate on a sufficiently large portion of $[0, R]$ ($\rho \geq M\alpha^{\frac{1}{4}}$). \square

In the following lemma we show that almost all level-sets admit a point with large X -horospheres and Y -horospheres.

Lemma 8.7.7. *There exists a constant $0 < \alpha(\infty) \leq 1$ such that for all $0 < \alpha \leq \alpha(\infty)$ the following statement holds. Let $U \subset \mathcal{B}$ be such that $\lambda(U) \geq (1 - \alpha)\lambda(\mathcal{B})$. Then there exists $U' \subset U$ such that:*

1. $\lambda(U') \geq (1 - \alpha^{\frac{1}{4}})\lambda(\mathcal{B})$
2. For all $z \in h(U')$ there exists $(x_{0,z}, y_{0,z}) \in U'_z$ such that for all $(x_1, y_1) \in U'_z$, we have $(x_1, y_{0,z}) \in U'_z$ and $(x_{0,z}, y_1) \in U'_z$.

Proof. We may assume without loss of generality that $h(\mathcal{B}) = [0, R[$. Let us denote by

$$H_U := \left\{ z \in [0, R[\mid \lambda_z(U_z) \geq \left(1 - \alpha^{\frac{1}{4}}\right) \lambda_z(\mathcal{B}_z) \right\}$$

Then we claim that $\text{Leb}(H_U) \geq (1 - \alpha^{\frac{1}{4}})R$. To prove this claim we proceed by contradiction. Let us assume that $\text{Leb}(H_U) < (1 - \alpha^{\frac{1}{4}})R$, then $\text{Leb}([0, R[\setminus H_U) \geq \alpha^{\frac{1}{4}}R$. Furthermore, for all $z \in [0, R[\setminus H_U$ we have $\lambda_z(U_z) < (1 - \alpha^{\frac{1}{4}})\lambda_z(\mathcal{B}_z)$, hence

$$\lambda_z(\mathcal{B}_z \setminus U_z) \geq \alpha^{\frac{1}{4}}\lambda_z(\mathcal{B}_z) \quad (8.17)$$

Therefore, by computing the measure of $\mathcal{B} \setminus U$ we have

$$\begin{aligned} \lambda(\mathcal{B} \setminus U) &= \int_{z \in [0, R[} \lambda_z(\mathcal{B}_z \setminus U_z) \, dz \geq \int_{z \in ([0, R[\setminus H_U)} \lambda_z(\mathcal{B}_z \setminus U_z) \, dz \\ &\geq \int_{z \in ([0, R[\setminus H_U)} \alpha^{\frac{1}{4}}\lambda_z(\mathcal{B}_z) \, dz, \quad \text{by inequality (8.17),} \\ &\geq_X \alpha^{\frac{1}{2}}\lambda(\mathcal{B}), \quad \text{by the contradiction assumption and Property 8.1.5,} \end{aligned}$$

which contradicts the assumption on U for α small enough. Hence $\text{Leb}(H_U) \geq (1 - \alpha^{\frac{1}{4}})R$.

Let us denote for $z \in [0; R[$

$$\begin{aligned} U^y &:= \{x \in \mathcal{B}_z^X \mid (x, y) \in U\} \\ H &:= \left\{ z \in [0, R[\mid \exists y \in \mathcal{B}_{-z}^Y, \lambda_z^X(U^y) \geq \left(1 - \alpha^{\frac{1}{4}}\right) \lambda_z^X(\mathcal{B}_z^X) \right\} \end{aligned}$$

In particular, for all $y \in \mathcal{B}_{-z}^Y$ we have $U^y \subset U_z^X$, and by the definition of λ

$$\lambda(U) = \int_{z \in [0, R[} \int_{y \in \mathcal{B}_{-z}^Y} \lambda_z^X(U^y).$$

We claim that $\text{Leb}(H) \geq (1 - \alpha^{\frac{1}{4}})R$. To prove this claim, we also proceed by contradiction. Let us assume that $\text{Leb}(H) < (1 - \alpha^{\frac{1}{4}})R$, then $\text{Leb}([0, R[\setminus H) \geq \alpha^{\frac{1}{4}}R$. Furthermore for all $z \in [0, R[\setminus H$ we have that

$$\forall y \in \mathcal{B}_{-z}^Y, \lambda_z^X(U^y) < \left(1 - \alpha^{\frac{1}{4}}\right) \lambda_z^X(\mathcal{B}_z^X)$$

Therefore, by the definition of U_y we have that $\forall y \in \mathcal{B}_{-z}^Y$

$$\lambda_z^X(\{x \in \mathcal{B}_z^X \mid (x, y) \notin U\}) \geq \alpha^{\frac{1}{4}}\lambda_z^X(\mathcal{B}_z^X) \quad (8.18)$$

Hence, by computing the measure of $\mathcal{B} \setminus U$ we have

$$\begin{aligned}
\lambda(\mathcal{B} \setminus U) &= \int_{z \in [0, R[} \int_{y \in \mathcal{B}_{-z}^Y} \lambda_z^X(\{x \in U_z^X \mid (x, y) \notin U\}) d\lambda_{-z}^Y dz \\
&\geq \int_{z \in ([0, R[\setminus H)} \int_{y \in \mathcal{B}_{-z}^Y} \lambda_z^X(\{x \in U_z^X \mid (x, y) \notin U\}) d\lambda_{-z}^Y dz \\
&\geq \int_{z \in ([0, R[\setminus H)} \int_{y \in \mathcal{B}_{-z}^Y} \alpha^{\frac{1}{4}} \lambda_z^X(\mathcal{B}_z^X) d\lambda_{-z}^Y dz, \quad \text{by inequality (8.18),} \\
&= \alpha^{\frac{1}{4}} \int_{z \in ([0, R[\setminus H)} \lambda_{-z}^Y(\mathcal{B}_{-z}^Y) \lambda_z^X(\mathcal{B}_z^X) dz \\
&\geq_X \alpha^{\frac{1}{4}} \alpha^{\frac{1}{4}} \lambda(\mathcal{B}) = \alpha^{\frac{1}{2}} \lambda(\mathcal{B}), \quad \text{by the contradiction assumption and Property 8.1.5,}
\end{aligned}$$

which contradicts the assumption $\lambda(\mathcal{B} \setminus U) < \alpha \lambda(\mathcal{B})$, for $\alpha < \frac{1}{M(\kappa)^2}$. Let us denote for all $x \in \mathcal{B}_z^X$

$$\begin{aligned}
U^x &:= \{y \in \mathcal{B}_{-z}^Y \mid (x, y) \in U\} \\
H' &:= \left\{z \in [0, R[\mid \exists x \in \mathcal{B}_z^X, \lambda_{-z}^Y(U^x) \geq \left(1 - \alpha^{\frac{1}{4}}\right) \lambda_{-z}^Y(\mathcal{B}_{-z}^Y)\right\}
\end{aligned}$$

We show similarly that $\text{Leb}(H') \geq \left(1 - \alpha^{\frac{1}{4}}\right) R$, therefore $\text{Leb}(H \cap H' \cap H_U) \geq \left(1 - 3\alpha^{\frac{1}{4}}\right) R$

For all $z \in H \cap H'$ there exists $(x_{0,z}, y_{0,z}) \in \mathcal{B}_z$ such that for all $(x_1, y_1) \in U_z$ we have

$$\lambda_z^X(U^{y_0}) \geq \left(1 - \alpha^{\frac{1}{4}}\right) \lambda_z^X(\mathcal{B}_z^X) \quad (8.19)$$

$$\lambda_{-z}^Y(U^{x_0}) \geq \left(1 - \alpha^{\frac{1}{4}}\right) \lambda_{-z}^Y(\mathcal{B}_{-z}^Y) \quad (8.20)$$

Let us define for all $z \in H_U \cap H \cap H'$, $U'_z := (U^{x_{0,z}} \times U^{y_{0,z}})$. Then we have:

1. $U' \subset U$
2. $\lambda_z(U'_z) = \lambda_z((U^{x_{0,z}} \times U^{y_{0,z}}) \cap U_z) \geq \left(1 - 3\alpha^{\frac{1}{4}}\right) \lambda_z(\mathcal{B})$ by inequalities (8.19), (8.20) and by the definition of H_U .
3. For all $(x_1, y_1) \in U'_z$ we have $(x_1, y_{0,z}) \in U'_z$ and $(x_{0,z}, y_1) \in U'_z$

Let $(x_1, y_1) \in U'_z$, then $(x_1, y_{0,z}) \in U'$ hence $(x_{0,z}, y_{0,z}) \in U'$. Furthermore we have that $\text{Leb}(H_U \cap H \cap H') \geq \left(1 - 3\alpha^{\frac{1}{4}}\right) R$, hence $\text{Leb}([0, R[\setminus (H_U \cap H \cap H')) \leq 3\alpha^{\frac{1}{4}} R$. Therefore

$$\begin{aligned}
\lambda(\mathcal{B} \setminus U') &= \int_{z \in [0, R[} \lambda_z((\mathcal{B} \setminus U')_z) dz \\
&= \int_{z \in ([0, R[\setminus (H_U \cap H \cap H'))} \lambda_z(\mathcal{B}_z \setminus (U^{x_{0,z}} \times U^{y_{0,z}})) dz \\
&\leq \int_{z \in ([0, R[\setminus (H_U \cap H \cap H'))} \left(3\alpha^{\frac{1}{4}}\right) \lambda_z(\mathcal{B}_z) dz, \quad \text{by construction of } U'_z \\
&\leq_X 9\alpha^{\frac{1}{2}} \lambda(\mathcal{B}), \quad \text{by the measure of } [0, R[\setminus (H_U \cap H \cap H') \text{ and by Property 8.1.5.}
\end{aligned}$$

Hence $\lambda(U') \geq \left(1 - \alpha^{\frac{1}{4}}\right) \lambda(\mathcal{B})$, since $\alpha^{\frac{1}{4}} > 9M(X)\alpha^{\frac{1}{2}}$ (α small enough in comparison to a constant depending only on X). \square

These points $(x_{0,z}, y_{0,z})$ will play a key role in the definition of the product map close to a given self quasi-isometry in Theorems 9.2.1 and 9.2.1

8.8 Divergence

Two distinct vertical geodesics in a δ -hyperbolic and Busemann space diverge quickly from each other. However this statement, based on Corollary 6.0.3, depends on the pair of geodesics. The next lemma aims at making this more precise for X an admissible horo-pointed space. More specifically we are going to look at a point x and at all the vertical geodesic passing by a point of the disc centred at x of radius M_0 (the $(E2)$ constant) along the horosphere at height $h(x)$, that is $VD_{M_0}(x)$. Let V_0 be a geodesic containing x , we want to quantify the vertical geodesics in $VD_{M_0}(x)$ which start diverging from the vertical geodesic V_0 between the heights $h(x) - l$ and $h(x) + l$. We shall denote this set by $\text{Div}(V_0)$:

$$\text{Div}(V_0) := \{V \in VD_{M_0}(x) \mid |h_{\text{Div}}(V_0, V) - h(x)| \leq l\}$$

Lemma 8.8.1. *With the above notations we have*

$$\eta^X(VD_{M_0}(x) \setminus \text{Div}(V_0)) \leq_X e^{-ml} \eta^X(VD_{M_0}(x))$$

Proof. We might, by slight abuse of notations, intersect a set of vertical geodesics segments $E \subset V\mathcal{B}$ with a subset $F \subset \mathcal{B}$, it means that we consider the intersection between F and the union of the images of E . For example:

$$VD_{M_0}(x) \cap \mathcal{B}_{h(x)} = D_{M_0}(x).$$

Any vertical geodesic segment $V \in VD_{M_0}(x)$ did not start to diverge from the vertical geodesic V_0 at the height $h(x)$, we have $h_{\text{Div}}(V, V_0) \leq h(x)$. Therefore, all the vertical geodesic segments which did not start to diverge at the height $h(x) - l$, denoted by $VD_{M_0}(x) \setminus \text{Div}(V_0)$, are still M_0 -close to $\pi_{h(x)-l}(x)$:

$$(VD_{M_0}(x) \setminus \text{Div}(V_0)) \cap \mathcal{B}_{h(x)-l} \subset D_{M_0}(\pi_{h(x)-l}(x)) \quad (8.21)$$

We use Lemma 6.0.6 with $z_0 = h(x)$ and $z = h(x) - l$, which gives

$$D_{2l-M_0}(\pi_{h(x)-l}(x)) \subset \pi_{h(x)-l}(D_{M_0}(x)) = VD_{M_0}(x) \cap \mathcal{B}_{h(x)-l} \quad (8.22)$$

Therefore

$$\begin{aligned} \frac{\eta^X(VD_{M_0}(x) \setminus \text{Div}(V_0))}{\eta^X(VD_{M_0}(x))} &\underset{X}{\sim} \frac{\lambda_{h(x)-l}^X(VD_{M_0}(x) \setminus \text{Div}(V_0) \cap \mathcal{B}_{h(x)-l})}{\lambda_{h(x)-l}^X(VD_{M_0}(x) \cap \mathcal{B}_{h(x)-l})}, \quad \text{by Property 8.6.5,} \\ &\leq \frac{\lambda_{h(x)-l}^X(D_{M_0}(\pi_{h(x)-l}(x)))}{\lambda_{h(x)-l}^X(VD_{M_0}(x) \cap \mathcal{B}_{h(x)-l})}, \quad \text{by inequality 8.21} \\ &\leq \frac{\lambda_{h(x)-l}^X(D_{M_0}(\pi_{h(x)-l}(x)))}{\lambda_{h(x)-l}^X(D_{2l-M_0}(\pi_{h(x)-l}(x)))}, \quad \text{by inequality 8.22.} \end{aligned}$$

Moreover by the definition of λ^X and Lemma 8.1.2

$$\frac{\lambda_{h(x)-l}^X(D_{M_0}(\pi_{h(x)-l}(x)))}{\lambda_{h(x)-l}^X(D_{2l-M_0}(\pi_{h(x)-l}(x)))} = \frac{\mu_{h(x)-l}^X(D_{M_0}(\pi_{h(x)-l}(x)))}{\mu_{h(x)-l}^X(D_{2l-M_0}(\pi_{h(x)-l}(x)))} \leq_X e^{-ml}. \quad (8.23)$$

Therefore

$$\frac{\eta^X(VD_{M_0}(x) \setminus \text{Div}(V_0))}{\eta^X(VD_{M_0}(x))} \leq_X e^{-ml}.$$

□

Heuristically, the previous lemma asserts that most of the vertical geodesics segments passing close to a point x , start diverging from each other close to the height $h(x)$.

We now provide an estimate on the exponential contraction of the measure μ along the vertical direction.

Lemma 8.8.2. *There exists $M(\varkappa)$ such that the following holds. Let $h_0 \in \mathbb{R}$, let $U \subset (X \varkappa Y)_{h_0}$ be a measurable subset. Let $\Delta > M$ and let $A \subset (X \varkappa Y)_{h_0-\Delta}$ be a measurable subset. Suppose also that all vertical rays V intersecting U intersect A . Then*

$$\mu_{h_0-\Delta}(A) \geq_{\varkappa} e^{(m-n)\Delta} \mu_{h_0}(U)$$

Proof. Since $\pi_{h_0-\Delta}^{\varkappa}(U) \subset A$ we have

$$\mu_{h_0-\Delta}(\pi_{h_0-\Delta}^{\varkappa}(U)) \leq \mu_{h_0-\Delta}(A)$$

Where π^{\varkappa} is defined in Notations [6.0.9](#). We recall that for all $x \in X$, $U_x^Y := \{y \in Y \mid (x, y) \in U\}$. By definition

$$\mu_{h_0}(U) = \mu_{h_0}^X \otimes \mu_{-h_0}^Y(U) = \int_{X_{h_0}} \mu_{-h_0}^Y(U_x^Y) d\mu_{h_0}^X(x) \quad (8.24)$$

For all $x \in U^X$ let us denote $U_x := \{(x, y) \in U \mid y \in U^Y\}$, then

$$(U_x)^Y = U_x^Y := \{y \in Y \mid (x, y) \in U\}$$

Furthermore $U_x^Y \subset \pi_{\Delta-h_0}^Y[\pi_{\Delta-h_0}^Y(U_x^Y)]$, hence

$$\mu_{-h_0}^Y(U_x^Y) \leq \mu_{-h_0}^Y(\pi_{\Delta-h_0}^Y[\pi_{\Delta-h_0}^Y(U_x^Y)]) \lesssim_{\varkappa} e^{n\Delta} \mu_{\Delta-h_0}^Y[\pi_{\Delta-h_0}^Y(U_x^Y)], \quad \text{by assumption (E3),}$$

which gives us,

$$\mu_{h_0}(U) \leq_{\varkappa} e^{n\Delta} \int_{U^X} \mu_{\Delta-h_0}^Y[\pi_{\Delta-h_0}^Y(U_x^Y)] d\mu_{h_0}^X(x), \quad \text{by definition of } \mu_{h_0}. \quad (8.25)$$

However we have

$$\begin{aligned} \pi_{\Delta-h_0}^Y(U_x^Y) &= (\pi_{h_0-\Delta}^{\varkappa}(U_x))^Y = (\pi_{h_0-\Delta}^{\varkappa}(U))^Y_{\pi_{h_0-\Delta}^X(x)} \\ &= \left\{ y \in (\pi_{h_0-\Delta}^{\varkappa}(U))^Y \mid (\pi_{h_0-\Delta}^X(x), y) \in \pi_{h_0-\Delta}^{\varkappa}(U) \right\} \end{aligned} \quad (8.26)$$

Hence

$$\begin{aligned} \mu_{h_0}(U) &\leq_{\varkappa} e^{n\Delta} \int_{U^X} \mu_{\Delta-h_0}^Y \left[(\pi_{h_0-\Delta}^{\varkappa}(U))^Y_{\pi_{h_0-\Delta}^X(x)} \right] d\mu_{h_0}^X(x), \quad \text{by (8.25) and (8.26),} \\ &= e^{n\Delta} \int_{\pi_{h_0-\Delta}^X(U^X)} \mu_{\Delta-h_0}^Y \left[(\pi_{h_0-\Delta}^{\varkappa}(U))^Y_{x'} \right] d\pi_{h_0}^X * \mu_{h_0}^X(x') \\ &\lesssim_{\varkappa} e^{n\Delta} e^{-m\Delta} \int_{\pi_{h_0-\Delta}^X(U^X)} \mu_{\Delta-h_0}^Y \left[(\pi_{h_0-\Delta}^{\varkappa}(U))^Y_{x'} \right] d\mu_{h_0-\Delta}^X(x'), \quad \text{by assumption (E3).} \\ &= e^{(n-m)\Delta} \mu_{h_0-\Delta}(\pi_{h_0-\Delta}^{\varkappa}(U)) \end{aligned}$$

Furthermore, as said at the beginning we have $\mu_{h_0-\Delta}(\pi_{h_0-\Delta}^{\varkappa}(U)) \leq \mu_{h_0-\Delta}(A)$, therefore

$$\mu_{h_0-\Delta}(A) \geq_{\varkappa} e^{(m-n)\Delta} \mu_{h_0}(U).$$

□

In the next Lemma we transfer a control on the measure μ to a control on the measure η .

Lemma 8.8.3. *Let M_0 be the constant involved in assumption (E2), \mathcal{B} be a box and $z \in h(\mathcal{B})$. Let $A \subset (\mathcal{B})_z$ and let $E \subset \mathcal{B}$ such that $h^+(E) \leq h(A)$. Then, if there exists $Q \geq 1$ such that $\mu(\mathcal{N}_{M_0}(E)) \leq Q^{-1}\mu(\mathcal{N}_{M_0}(A))$, we have that*

$$\eta(V\mathcal{N}_{M_0}(E)) \leq_{\asymp} Q^{-1}\eta(V\mathcal{N}_{M_0}(A))$$

Proof. Let $Z \subset E$ be a $2M_0$ -maximal separating set, we have:

1. The balls $B(p, M_0)$ for $p \in Z$ are pairwise disjoint.
2. We have the following inclusions:

$$\bigsqcup_{p \in Z} B(p, M_0) \subset \mathcal{N}_{M_0}(E) \subset \bigcup_{p \in Z} B(p, 3M_0)$$

The radius $3M_0$ is required since we cover all $\mathcal{N}_{M_0}(E)$ and not only E . Furthermore, all balls and disks of radius M_0 have comparable measure μ by assumption (E2) and Corollary (8.5.4), therefore

$$\mu(\mathcal{N}_{M_0}(E)) \asymp \#Z \asymp \sum_{p \in Z} \mu(B(p, M_0)) \asymp \sum_{p \in Z} \mu_{h(p)}(D_{M_0}(p)) \quad (8.27)$$

Moreover, for all $v \in VE$, there exists $p \in Z$ such that $v \cap D_{3M_0}(p) \neq \emptyset$. Consequently we have $V\mathcal{N}_{M_0}(E) \subset \bigcup_{p \in Z} VD_{3M_0}(p)$, hence

$$\begin{aligned} \eta(V\mathcal{N}_{M_0}(E)) &\leq \sum_{p \in Z} \eta(VD_{3M_0}(p)) \asymp_X \sum_{p \in Z} \lambda_{h(p)}(VD_{3M_0}(p)), \quad \text{by Property (8.6.5)} \\ &\leq \sum_{p \in Z} \lambda_{h(p)}^X(VD_{6M_0}(p^X)) \lambda_{-h(p)}^Y(VD_{6M_0}(p^Y)). \end{aligned}$$

Furthermore, disks of radius r are included in rectangles of width $2r$, hence

$$\begin{aligned} \eta(V\mathcal{N}_{M_0}(E)) &\leq_{\asymp} \sum_{p \in Z} e^{h(p)(m-n)} \mu_{h(p)}(VD_{6M_0}(p)), \quad \text{by the definition of } \lambda_{h(p)}, \\ &\leq e^{h(a)(m-n)} \sum_{p \in Z} \mu_{h(p)}(VD_{3M_0}(p)), \quad \text{because } h^+(E) \leq h(A), \\ &\leq e^{h(a)(m-n)} \mu(E), \quad \text{by inequalities (8.27)}. \end{aligned}$$

Using similar arguments we obtain

$$\eta(V\mathcal{N}_{M_0}(A)) \asymp \lambda_{h(a)}(V\mathcal{N}_{M_0}(A)) \asymp e^{h(a)(m-n)} \mu(V\mathcal{N}_{M_0}(A))$$

Combined with the assumption $\mu(\mathcal{N}_{M_0}(E)) \leq Q^{-1}\mu(\mathcal{N}_{M_0}(A))$ we have

$$\eta(V\mathcal{N}_{M_0}(A)) \geq_{\asymp} e^{h(a)(m-n)} Q \mu(\mathcal{N}_{M_0}(E)) \geq_{\asymp} Q^{-1} \eta(V\mathcal{N}_{M_0}(E)).$$

□

Heuristically, if a set E is sufficiently small and below a set A , then the set of vertical geodesic segments intersecting E will also be small.

Chapter 9

Proof of the geometric rigidity

The aim of this chapter is to present a proof of our key result.

Theorem 9.0.1. *Assume that $m > n$ and let $\Phi : X \rtimes Y \rightarrow X \rtimes Y$ be a (k, c) quasi-isometry. Then there exist two quasi-isometries $\Phi^X : X \rightarrow X$ and $\Phi^Y : Y \rightarrow Y$ such that*

$$d_{\rtimes}(\Phi, (\Phi^X, \Phi^Y)) \leq_{k,c,\rtimes} 1$$

Although this statement is similar to the statement in the case of Sol and Diestel-Leader, our broader setting of admissible spaces requires additional key arguments, such as lemma [8.1.3](#), and therefore relies heavily on the previous sections.

To make the exposition of the various statements in this chapter smoother, we made the following abuse of notation. In a statement, when a parameter, say θ , need to be sufficiently small, we will write it by "For $\theta \leq_{\rtimes} 1$ we have ..." instead of "There exists a constant $M(\rtimes)$ such that if $\theta \leq \frac{1}{M}$, then ...". From now until the end of this chapter we consider $\Phi : X \rtimes Y \rightarrow X \rtimes Y$ a (k, c) -quasi-isometry with fixed constants $k \geq 1$ and $c \geq 0$.

9.1 Vertical geodesics with ε -monotone image

In order to construct a product map, the key idea is to use the quadrilateral lemmas of Section [7.4](#) on the image by the quasi-isometry Φ of a quadrilateral in $X \rtimes Y$. To do so we need to locate which vertical geodesic segments are sent close to vertical geodesic segments. Thanks to Proposition [7.1.4](#) it is sufficient to look for vertical geodesic segments with an ε -monotone image under Φ , where $0 \leq \varepsilon < 1$ is a parameter to be determined later (depending on \rtimes, k and c). We call *good* these vertical geodesic segments.

Notation 9.1.1. *We recall that we denote $V\mathcal{B}$ the set of vertical geodesic segments of the box \mathcal{B} . Let us denote by $V^g\mathcal{B}$ the set of good vertical geodesic segments and $V^b\mathcal{B}$ the set of bad vertical geodesic segments, that is*

$$\begin{aligned} V^g\mathcal{B} &:= \{\gamma \in V\mathcal{B} \mid \Phi \circ \gamma \text{ is } \varepsilon\text{-monotone}\} \\ V^b\mathcal{B} &:= \{\gamma \in V\mathcal{B} \mid \Phi \circ \gamma \text{ is not } \varepsilon\text{-monotone}\} = V\mathcal{B} \setminus V^g\mathcal{B} \end{aligned}$$

In the following lemma, we prove the existence of an appropriate scale on which almost all boxes possess almost only good vertical geodesics. We shall denote by $\eta := \eta_{V\mathcal{B}}, \eta^X := \eta_{V^X\mathcal{B}^X}$ and $\eta^Y := \eta_{V^Y\mathcal{B}^Y}$.

Proposition 9.1.2. *For $0 < \theta \leq_{\rtimes} 1$, there exist two positive constants $M(k, c, \rtimes, \varepsilon)$ and $M'(k, c, \rtimes)$ such that for all $r_0 \geq M, N \geq \frac{M'}{\varepsilon}$ and $S \geq \frac{M'}{\varepsilon\theta}$ and boxes \mathcal{B} at scale $L := N^S r_0$, there exist $k_0 \in \{1, \dots, S\}$, a box tiling $\bigsqcup_{i \in I} \mathcal{B}_i = \mathcal{B}$ at scale $R = N^{k_0} r_0$ and $I_g \subset I$ such that:*

1. $\lambda\left(\bigcup_{i \in I_g} \mathcal{B}_i\right) \geq (1 - \theta)\lambda(\mathcal{B})$ (Boxes indexed by I_g cover almost all \mathcal{B})
2. $\forall i \in I_g, \frac{\eta_i(V^b \mathcal{B}_i)}{\eta_i(V \mathcal{B}_i)} \leq \theta$ (almost all vertical geodesic segments in \mathcal{B}_i have ε -monotone image)

where $\eta_i := \eta_{V \mathcal{B}_i}$.

Proof. We recall from Lemma 7.2.2 the definition of $\delta_s(\alpha)$ for a quasi-geodesic segment α .

$$A_s := \left\{ \alpha([kN^s r_0, (k+1)N^s r_0]) \mid k \in \{0, \dots, N^{S-s} - 1\} \right\},$$

Then $\delta_s(\alpha)$ is the proportion of segments in A_s which are not ε -monotone:

$$\delta_s(\alpha) := \frac{\#\{\beta \in A_s \mid \beta \text{ is not } \varepsilon\text{-monotone}\}}{\#A_s}. \quad (9.1)$$

Using Proposition 7.2.2 on every vertical geodesic segment in \mathcal{B} we have that $\forall \alpha \in V\mathcal{B}$

$$\sum_{s=1}^S \delta_s(\alpha) \leq_{\varkappa, k, c} \frac{1}{\varepsilon}. \quad (9.2)$$

We now integrate the inequality (9.2) with respect to η over $V\mathcal{B}$ to get

$$\frac{1}{\varepsilon} \geq_{\varkappa, k, c} \frac{1}{\eta(V\mathcal{B})} \int_{\alpha \in V\mathcal{B}} \left(\sum_{s=1}^S \delta_s(\alpha) \right) d\eta = \sum_{s=1}^S \left(\frac{1}{\eta(V\mathcal{B})} \int_{\alpha \in V\mathcal{B}} \delta_s(\alpha) d\eta \right).$$

Consequently there exists $k_0 \in \{1, \dots, S\}$ such that

$$\frac{1}{\eta(V\mathcal{B})} \int_{\alpha \in V\mathcal{B}} \delta_{k_0}(\alpha) d\eta \leq_{\varkappa, k, c} \frac{1}{S\varepsilon} \leq_{\varkappa} \theta, \quad \text{by assumption on } S. \quad (9.3)$$

From now on we denote $R := N^{k_0} r_0$. There are $\frac{L}{R}$ layers of boxes at scale R in \mathcal{B} . We average $\delta_{k_0}(\alpha)$ along all $\alpha \in V\mathcal{B}$:

$$\begin{aligned} \frac{1}{\eta(V\mathcal{B})} \int_{\alpha \in V\mathcal{B}} \delta_{k_0}(\alpha) d\eta &= \frac{1}{\eta(V\mathcal{B})} \int_{\alpha \in V\mathcal{B}} \frac{R}{L} \sum_{k=0}^{\frac{L}{R}-1} \delta_{k_0}(\alpha([kR; (k+1)R])) d\eta \\ &= \frac{1}{\eta(V\mathcal{B})} \frac{R}{L} \sum_{k=0}^{\frac{L}{R}-1} \int_{\alpha \in V\mathcal{B}} \delta_{k_0}(\alpha([kR; (k+1)R])) d\eta \end{aligned} \quad (9.4)$$

Let us denote by $\mathcal{B}_{[k]} := \mathcal{B} \cap h^{-1}([kR; (k+1)R])$ the k -th layer of \mathcal{B} . Since vertical geodesic segments of $X \rtimes Y$ are couples of vertical geodesic segments, $V\mathcal{B}_{[k]}$ is in bijection with $V\mathcal{B}_{[k]}^X \times V\mathcal{B}_{[k]}^Y$ which is itself in bijection with $\mathcal{B}_{kR}^X \times \mathcal{B}_{-(k+1)R}^Y$ as explained in Section 8.6. Let us denote by f this bijection.

$$\begin{aligned} f : \mathcal{B}_{[k]} &\rightarrow \mathcal{B}_{kR}^X \times \mathcal{B}_{-(k+1)R}^Y \\ \alpha &\mapsto (\alpha^X(kR), \alpha^Y(-(k+1)R)) \end{aligned}$$

For all $\alpha \in V\mathcal{B}$ and for all $k \in \{0, \dots, \frac{L}{R} - 1\}$ we have $\delta_{k_0}(\alpha([kR; (k+1)R])) = 0$ or 1 , hence

$$\begin{aligned} \delta_{k_0}(\alpha([kR; (k+1)R])) &= \mathbb{1}_{V^b \mathcal{B}_{[k]}}(\alpha([kR; (k+1)R])) \\ &= \mathbb{1}_{f(V^b \mathcal{B}_{[k]})}(\alpha_X((k+1)R), \alpha_Y(-kR)) \end{aligned}$$

Therefore

$$\begin{aligned}
 & \int_{\alpha \in V\mathcal{B}} \delta_{k_0}(\alpha([kR; (k+1)R]) d\eta \\
 &= \int_{(\alpha^X, \alpha^Y) \in V\mathcal{B}^X \times V\mathcal{B}^Y} \mathbb{1}_{f(V^b\mathcal{B}_{[k]})}(\alpha^X((k+1)R), \alpha^Y(-kR)) d\eta^X d\eta^Y \\
 &= \int_{(x, y) \in \mathcal{B}_0^X \times \mathcal{B}_{-L}^Y} \mathbb{1}_{f(V^b\mathcal{B}_{[k]})}(\pi_{kR}^X(x), \pi_{-(k+1)R}^Y(y)) d\lambda_0^X d\lambda_{-L}^Y, \quad \text{by definition } \eta^X \text{ and } \eta^Y, \\
 &\stackrel{\approx}{\asymp} \int_{(x', y') \in \mathcal{B}_{kR}^X \times \mathcal{B}_{-(k+1)R}^Y} \mathbb{1}_{f(V^b\mathcal{B}_{[k]})}(x', y') d\lambda_{kR}^X d\lambda_{-(k+1)R}^Y, \quad \text{by Property } \boxed{8.1.5}. \tag{9.5}
 \end{aligned}$$

Let $\sqcup_{i \in I} \mathcal{B}_i$ be the box tiling at scale R as in Proposition [8.3.1](#), and for all $k \in \{0, \dots, N-1\}$ let us denote by $I_k \subset I$ the indices of the boxes \mathcal{B}_i which tile $\mathcal{B}_{[k]}$. Then we have $V\mathcal{B}_{[k]} = \sqcup_{i \in I_k} V\mathcal{B}_i$ and $V^b\mathcal{B}_{[k]} = \sqcup_{i \in I_k} V^b\mathcal{B}_i$. Therefore for all $(x, y) \in \mathcal{B}_{kR}^X \times \mathcal{B}_{-(k+1)R}^Y$

$$\mathbb{1}_{f(V^b\mathcal{B}_{[k]})}(x, y) = \mathbb{1}_{f(\sqcup_{i \in I_k} V^b\mathcal{B}_i)}(x, y) = \sum_{i \in I_k} \mathbb{1}_{f(V^b\mathcal{B}_i)}(x, y)$$

Hence from inequality [\(9.5\)](#) we have

$$\begin{aligned}
 & \int_{\alpha \in V\mathcal{B}} \delta_{k_0}(\alpha([kR; (k+1)R]) d\eta \stackrel{\approx}{\asymp} \int_{(x, y) \in \mathcal{B}_{kR}^X \times \mathcal{B}_{-(k+1)R}^Y} \sum_{i \in I_k} \mathbb{1}_{f(V^b\mathcal{B}_i)}(x, y) d\lambda_{kR}^X d\lambda_{-(k+1)R}^Y \\
 &= \sum_{i \in I_k} \int_{(x, y) \in \mathcal{B}_{kR}^X \times \mathcal{B}_{-(k+1)R}^Y} \mathbb{1}_{f(V^b\mathcal{B}_i)}(x, y) d\lambda_{kR}^X d\lambda_{-(k+1)R}^Y \\
 &= \sum_{i \in I_k} \int_{\alpha \in V\mathcal{B}_i} \mathbb{1}_{V^b\mathcal{B}_i}(\alpha) d\eta_i = \sum_{i \in I_k} \eta_i(V^b\mathcal{B}_i)
 \end{aligned}$$

In combination with inequality [\(9.4\)](#) we have

$$\begin{aligned}
 \frac{1}{\eta(V\mathcal{B})} \int_{\alpha \in V\mathcal{B}} \delta_{k_0}(\alpha) d\eta &\geq \frac{1}{\eta(V\mathcal{B})} \frac{R}{L} \sum_{k=0}^{\frac{L}{R}-1} \sum_{i \in I_k} \eta_i(V^b\mathcal{B}_i) \\
 &\geq \sum_{i \in I} \frac{R\eta_i(V\mathcal{B}_i)}{L\eta(V\mathcal{B})} \frac{\eta_i(V^b\mathcal{B}_i)}{\eta_i(V\mathcal{B}_i)} \\
 &\geq \sum_{i \in I} \frac{\lambda(\mathcal{B}_i)}{\lambda(\mathcal{B})} \frac{\eta_i(V^b\mathcal{B}_i)}{\eta_i(V\mathcal{B}_i)}, \quad \text{by Property } \boxed{8.6.4}
 \end{aligned}$$

Let us denote by I_b the set of indices i of boxes \mathcal{B}_i such that $\frac{\eta_i(V^b\mathcal{B}_i)}{\eta_i(V\mathcal{B}_i)} \geq \theta$, and $I_g := I \setminus I_b$. Thus defined I_g satisfies the second part of our proposition, and we are left with proving that it also satisfies the first part. To do so we assume by contradiction that $\lambda\left(\bigcup_{i \in I_b} \mathcal{B}_i\right) \geq \theta\lambda(\mathcal{B})$, then

$$\begin{aligned}
 \frac{1}{\eta(V\mathcal{B})} \int_{\alpha \in V\mathcal{B}} \delta_{k_0}(\alpha) d\eta &\geq \sum_{i \in I_b} \frac{\lambda(\mathcal{B}_i)}{\lambda(\mathcal{B})} \frac{\eta_i(V^b\mathcal{B}_i)}{\eta_i(V\mathcal{B}_i)}, \quad \text{since } I_b \subset I, \\
 &\geq \theta \frac{\sum_{i \in I_b} \lambda(\mathcal{B}_i)}{\lambda(\mathcal{B})}, \quad \text{by the definition of } I_b, \\
 &\geq \theta^2, \quad \text{by the contradiction assumption,}
 \end{aligned}$$

which contradicts inequality (9.3) for $\theta \leq_{\mathfrak{M}} 1$. Therefore $\lambda\left(\bigcup_{i \in I_b} \mathcal{B}_i\right) < \theta \lambda(\mathcal{B})$, hence $\lambda\left(\bigcup_{i \in I_g} \mathcal{B}_i\right) \geq (1 - \theta) \lambda(\mathcal{B})$. \square

Let \mathcal{B} be a box at scale R . Let us denote the upward and downward oriented vertical geodesic segments by

$$\begin{aligned} V^\uparrow \mathcal{B} &:= \{V \in V^g \mathcal{B} \mid h(\Phi \circ V(0)) \leq h(\Phi \circ V(R))\} \\ V^\downarrow \mathcal{B} &:= \{V \in V^g \mathcal{B} \mid h(\Phi \circ V(0)) \geq h(\Phi \circ V(R))\} \end{aligned}$$

We are now going to show that in a given box \mathcal{B}_i with $i \in I_g$, almost all vertical geodesic segments share the same orientation.

Lemma 9.1.3. *For $0 < \varepsilon^2 \leq_{k,c,\mathfrak{M}} \theta \leq_{k,c,\mathfrak{M}} 1$, and for $R \geq_{k,c,\mathfrak{M}} \frac{1}{\varepsilon}$ we have that if \mathcal{B} is a box at scale R such that $\eta(V^b \mathcal{B}) \leq \theta \eta(V \mathcal{B})$, then one of the two following statements holds:*

1. $\eta(V^\uparrow \mathcal{B} \cap V^g \mathcal{B}) \geq (1 - 3\sqrt{\theta}) \eta(V \mathcal{B})$
2. $\eta(V^\downarrow \mathcal{B} \cap V^g \mathcal{B}) \geq (1 - 3\sqrt{\theta}) \eta(V \mathcal{B})$

In the proof, we first characterise a set of vertical geodesic segment whose images share the same orientation, then we show that this set has almost full measure.

Proof. Without loss of generality we can assume that $h(\mathcal{B}) = [0, R[$. Let us denote by

$$\begin{aligned} G^Y(v^X) &:= \{v^Y \in V \mathcal{B}^Y \mid (v^X, v^Y) \in V^g \mathcal{B}\} \\ G^X &:= \{v^X \in V \mathcal{B}^X \mid \eta^Y(G^Y(v^X)) \geq (1 - \sqrt{\theta}) \eta^Y(V \mathcal{B}^Y)\} \end{aligned}$$

By construction we have

$$\bigcup_{v^X \in V \mathcal{B}^X} G^Y(v^X) = (V^g \mathcal{B})^Y$$

Applying Lemma 8.7.1 with $V_1 := V^g(\mathcal{B})$ and $\alpha := \theta$ we get

$$\eta^X(G^X) \geq (1 - \sqrt{\theta}) \eta^X(V \mathcal{B}^X) \quad (9.6)$$

Let $v_1^X : [0, R] \rightarrow X$ and $v_2^X : [0, R] \rightarrow X$ be two vertical geodesic segments of G^X , then

$$\begin{aligned} \eta^Y(G^Y(v_1^X)) &\geq (1 - \sqrt{\theta}) \eta^Y(V \mathcal{B}^Y) \\ \eta^Y(G^Y(v_2^X)) &\geq (1 - \sqrt{\theta}) \eta^Y(V \mathcal{B}^Y) \end{aligned}$$

Hence

$$\eta^Y(G^Y(v_1^X) \cap G^Y(v_2^X)) \geq (1 - 2\sqrt{\theta}) \eta^Y(V \mathcal{B}^Y) \quad (9.7)$$

Let $v_1^Y, v_2^Y \in G^Y(v_1^X) \cap G^Y(v_2^X)$ and let us denote by $V_{i,j} := (v_i^X, v_j^Y)$ with $i, j = 1, 2$. By definition of v_1^Y and v_2^Y , the quasigeodesic segments $\Phi(V_{i,j})$ are ε -monotone. two cases occur. As a first case let us assume that

$$\begin{aligned} d_X(v_1^X(0), v_2^X(0)) &> \sqrt{\theta} R \\ d_Y(v_1^Y(0), v_2^Y(0)) &> \sqrt{\theta} R \end{aligned}$$

Let M be the constant involved in Proposition 7.4.2. For $R \geq 4kc$ and $\varepsilon \leq \frac{\sqrt{\theta}}{20kM}$ we have that $\sqrt{\theta} R \geq 10kM\varepsilon R + 2kc$, hence we can apply Proposition 7.4.2 on $V_{1,1}$ and $V_{2,2}$, which gives us that

they share the same orientation.

The second case, that is when either $d_X(v_1^X(0), v_2^X(0)) \leq \sqrt{\theta}R$ or $d_Y(v_1^Y(0), v_2^Y(0)) \leq \sqrt{\theta}R$, is treated thanks to an auxiliary geodesic segment. Hence without loss of generality we focus on the case $d_X(v_1^X(0), v_2^X(0)) \leq \sqrt{\theta}R$ and consider a geodesic segment $v_3^X \in G^X$ verifying $d_X(v_1^X(0), v_3^X(0)) > \sqrt{\theta}R$ and $d_X(v_2^X(0), v_3^X(0)) > \sqrt{\theta}R$. To prove its existence, we consider the measure of

$$G^X \setminus V_{\mathcal{B}^X} \left(D_{\sqrt{\theta}R}(v_1^X(0)) \cup D_{\sqrt{\theta}R}(v_2^X(0)) \right) \quad (9.8)$$

Let M_0 be the constant of assumption (E2). By Lemma 8.1.2 we have for all $r_1 \geq r_2 > M_0$ and for all $x \in X_0$ that $\mu_0(D_{r_1}(x)) \asymp_{\kappa} e^{m \frac{r_1 - r_2}{2}} \mu_0(D_{r_2}(x))$, therefore

$$\lambda_0 \left(D_{\sqrt{\theta}R}(v_1^X(0)) \right) \leq_{\kappa} e^{m \frac{\sqrt{\theta}R - R}{2}} \lambda_0 \left(D_R(v_1^X(0)) \right) \leq e^{-m \frac{R}{4}} \lambda_0 \left(D_R(v_1^X(0)) \right), \quad \text{since } \theta \leq \frac{1}{4}. \quad (9.9)$$

Furthermore, by Lemma 6.0.6 the bottom of \mathcal{B} contains a disk of radius $2R - M_0$, hence by Lemma 8.1.2 we have $\eta^X(V_{\mathcal{B}^X}) \asymp_X \lambda_0(D_{2R}(v_1^X(0)))$. Combined with inequality 9.9 we have

$$\lambda_0 \left(D_{\sqrt{\theta}R}(v_1^X(0)) \right) \leq_{\kappa} e^{-m \frac{R}{4}} \eta^X(V_{\mathcal{B}^X}).$$

The same formula holds for v_2^X instead of v_1^X . By inequality 9.6 we have that

$$\eta^X(G^X) \geq (1 - \sqrt{\theta})\eta^X(V_{\mathcal{B}^X}) \geq \frac{1}{2}\eta^X(V_{\mathcal{B}^X}),$$

hence there exists $M(\kappa)$ such that

$$\begin{aligned} \eta^X \left(G^X \setminus V_{\mathcal{B}^X} \left(D_{\sqrt{\theta}R}(v_1^X(0)) \cup D_{\sqrt{\theta}R}(v_2^X(0)) \right) \right) &\geq \left(\frac{1}{2} - 2Me^{-m \frac{R}{4}} \right) \eta^X(V_{\mathcal{B}^X}) \\ &> 0, \quad \text{for } R \geq \frac{4}{m} \ln(4M + 1). \end{aligned}$$

Therefore there exists $v_3^X \in G^X$ such that

$$\begin{aligned} d_X(v_1^X(0), v_3^X(0)) &> \sqrt{\theta}R \\ d_X(v_2^X(0), v_3^X(0)) &> \sqrt{\theta}R \end{aligned}$$

Applying twice Lemma 7.4.2 first on $V_{1,1}$ and $V_{3,3}$, then on $V_{2,2}$ and $V_{3,3}$, we get that the $\Phi(V_{1,1})$ has the same orientation as $\Phi(V_{3,3})$ which has the same orientation as $\Phi(V_{2,2})$. Therefore $\Phi(V_{1,1})$ and $\Phi(V_{2,2})$ share the same orientation.

Let us fix $v_0^X \in \mathcal{B}^X$ and $v_0^Y \in G^Y(v_1^X)$. Then every image of a vertical geodesic segment $V \in \bigcup_{v^X \in G^X} \{v^X\} \times (G^Y(v_0^X) \cap G^Y(v^X))$ shares the same orientation as the image of (v_0^X, v_0^Y) . Furthermore

$$\begin{aligned} \eta \left(\bigcup_{v^X \in G^X} \{v^X\} \times (G^Y(v_1^X) \cap G^Y(v^X)) \right) &= \int_{v^X \in G^X} \eta^Y(G^Y(v_1^X) \cap G^Y(v^X)) d\eta^X \\ &\geq \int_{v^X \in G^X} (1 - 2\sqrt{\theta})\eta^Y(V_{\mathcal{B}^Y}) d\eta^X, \quad \text{by inequality 9.7,} \\ &= (1 - 2\sqrt{\theta})\eta^Y(V_{\mathcal{B}^Y})\eta^X(G^X) \\ &\geq (1 - 2\sqrt{\theta})\eta^Y(V_{\mathcal{B}^Y})(1 - \sqrt{\theta})\eta^X(V_{\mathcal{B}^X}), \quad \text{by inequality 9.6} \\ &\geq (1 - 3\sqrt{\theta})\eta(V_{\mathcal{B}}), \end{aligned}$$

which proves the lemma. \square

9.2 Factorisation of a quasi-isometry in small boxes

The Proposition 9.1.2 gives us two scales R and L such that all boxes at scale L can be tiled with boxes at scale R . Moreover, almost all of them, that is the \mathcal{B}_i for $i \in I_g$, contained almost only vertical geodesic segments with ε -monotone image under Φ .

A map $f : X \rtimes Y \rightarrow X \rtimes Y$ is called a **product map** if there exist two maps f^X and f^Y such that we have either $\forall p = (p^X, p^Y) \in X \rtimes Y$, $f(p) = (f^X(p^X), f^Y(p^Y))$ or $\forall p = (p^X, p^Y) \in X \rtimes Y$, $f(p) = (f^Y(p^Y), f^X(p^X))$.

In particular, when we denote by (f^X, f^Y) a product map, we implicitly assume that $h(x) + h(y) = 0$ implies $h(f^X(x)) + h(f^Y(y)) = 0$.

Theorem 9.2.1. *For $0 < \theta \leq \varepsilon \leq_{\aleph} 1$, $r_0 \geq_{\aleph} \frac{\varepsilon\sqrt{2}}{\varepsilon}$, $N \geq_{\aleph} 1$ and for $S \geq_{\aleph} \frac{1}{\varepsilon\theta^2}$, we have that for any $i \in I_g$, there exists a product map $\hat{\Phi}_i = (\hat{\Phi}_i^X, \hat{\Phi}_i^Y)$, and $U'_i \subset \mathcal{B}_i$ such that:*

1. $\lambda(U'_i) \geq (1 - \theta^{\frac{1}{8}}) \lambda(\mathcal{B}_i)$
2. For all $(x, y) \in U'_i$, $d(\Phi(x, y), \hat{\Phi}_i(x, y)) \leq_{k, c, \aleph} \varepsilon R$.

In particular we have $\Delta h(\Phi(x, y), \hat{\Phi}_i(x, y)) \leq_{k, c, \aleph} \varepsilon R$.

Since almost all the points in a good box are surrounded by almost only good vertical geodesic segment (Lemma 8.7.3), we show that given two points sharing the same X coordinates, we can almost always construct a quadrilateral verifying the hypotheses of Proposition 7.3.2.

Lemma 9.2.2. *Let M_0 be the constant of assumption (E2). For $0 < \theta \leq_{\aleph} 1$ and for $R \geq_{\aleph} \frac{1}{\theta}$, let \mathcal{B} be a box at scale R of $X \rtimes Y$. Let us assume the existence of a subset U of \mathcal{B} such that:*

- (a) $\lambda(U) \geq (1 - \theta)\lambda(\mathcal{B})$
- (b) For all $x \in U$, $\eta(V_{\mathcal{B}}^b(D_{M_0}(x))) \leq \sqrt{\theta}\eta(V_{\mathcal{B}}(D_{M_0}(x)))$

Then we have:

1. For all $a_1, a_2 \in U$ such that $a_1^X = a_2^X$, there exist $b_1, b_2 \in \mathcal{B}$ and four vertical geodesic segments $\gamma_{i,j}$ linking a_i to b_j such that a_1, a_2, b_1 and b_2 form a vertical quadrilateral with nodes of scale $D = \theta R$.
2. For $i, j \in \{1, 2\}$, $\Phi(\gamma_{i,j})$ has ε -monotone image under Φ .

By Lemma 8.7.3, the boxes \mathcal{B}_i , with $i \in I_g$, verify the assumptions of this Lemma. Moreover, we recall that a vertical quadrilateral satisfy the assumptions of Proposition 7.3.2.

Proof of Lemma 9.2.2. Let M_0 be the constant of assumption (E2). Let $a_1, a_2 \in U$. For $i \in \{1, 2\}$ let us denote $VD_i := V_{\mathcal{B}}(D_{M_0}(a_i))$ and $V^b D_i := V_{\mathcal{B}}^b(D_{M_0}(a_i))$. For all $v = (v^X, v^Y) \in V_{\mathcal{B}}$ and all $i \in \{1, 2\}$ let us denote by:

1. $E_i^Y(v^X) := \{v^Y \in VD_i^Y \mid (v^X, v^Y) \in V^b D_i\}$
2. $F_i^X := \{v^X \in VD_i^X \mid \eta^Y(E_i^Y(v^X)) \geq \theta^{\frac{1}{4}} \eta^Y(VD_i^Y)\}$

Thanks to Lemma 8.7.2, applied with $V_1 := V^b \mathcal{B}$, $\alpha := \sqrt{\theta}$ and $a = a_i$, we have that

$$\eta^X(F_i^X) < \theta^{\frac{1}{4}} \eta^X(VD_i^X) \quad (9.10)$$

Let us take a_1 and a_2 in U such that $a_1^X = a_2^X$, then $VD_1^X = VD_2^X$:

1. $\eta^X(VD_i^X \setminus (F_1^X \cup F_2^X)) \geq (1 - 2\theta^{\frac{1}{4}})\eta^X(VD_i^X)$
2. For all $x \in VD_i^X \setminus (F_1^X \cup F_2^X)$ and $i \in \{1, 2\}$ we have $\eta^Y(E_i^Y(v^X)) < \theta^{\frac{1}{4}}\eta^Y(VD_i^Y)$.

The sets $VD_i^X \setminus (F_1^X \cup F_2^X)$ enclose the vertical geodesics segments in \mathcal{B}^X passing close to $a_1^X = a_2^X$ such that almost all the induced vertical geodesic segments around a_1 and a_2 in \mathcal{B} are good (ie. have ε -monotone images under the quasi-isometry Φ).

Since we have a sufficient proportion of good vertical geodesic segments, we will be able to find several of them that intersect the same neighbourhood in two different points sufficiently far from each other. If $h(a_1^X) < \theta R$, the construction of the quadrilateral of Proposition 7.3.2 with $D = \theta R$ is straightforward since the four points a_1, a_2, b_1 and b_2 would be θR close, hence without loss of generality we may assume that $h(a_1^X) \geq \theta R$. Moreover, as we did before we can also suppose that $h(\mathcal{B}) = [0, R]$.

We apply Lemma 6.0.6 with $z_0 = h(a_1)$ and $z = h(a_1) - \theta R$ to get the following inclusions:

$$D_{2\theta R - M_0}^X(\pi_{h(a_1) - \theta R}(a_1^X)) \subset \pi_{h(a_1) - \theta R}(D_{M_0}(a_1^X)) \subset D_{2\theta R + M_0}^X(\pi_{h(a_1) - \theta R}(a_1^X)) \quad (9.11)$$

We now suppose by contradiction that any couple of good vertical geodesic segments does not diverge quickly. This means that they stay M_0 -close until they attain a height lower than $h(a_1^X) - \theta R$. Therefore

$$\pi_{h(a_1) - \theta R}(VD_i^X \setminus (F_1^X \cup F_2^X)) \subset D_{M_0}^X(\pi_{h(a_1) - \theta R}(a_1^X))$$

Thanks to the inclusions (9.11) we have $VD_{2\theta R - M_0}^X(\pi_{h(a_1) - \theta R}(a_1^X)) \subset VD_1^X$, hence, combined with Property 8.6.5 we obtain

$$\begin{aligned} \frac{\eta^X(VD_1^X \setminus (F_1^X \cup F_2^X))}{\eta^X(VD_1^X)} &\leq \frac{\lambda_{h(a_1) - \theta R}^X(D_{M_0}(\pi_{h(a_1) - \theta R}(a_1^X)))}{\lambda_{h(a_1) - \theta R}^X(D_{2\theta R}(\pi_{h(a_1) - \theta R}(a_1^X)))} \\ &\leq e^{m(M_0 - 2\theta R)}, \quad \text{by Lemma 8.1.2} \end{aligned}$$

which, for R large enough in comparison to $\frac{1}{\theta}$, contradicts the fact that $\eta^X(VD_1^X \setminus (F_1^X \cup F_2^X)) \geq (1 - 2\theta^{\frac{1}{4}})\eta^X(VD_1^X)$, the first conclusion of the previously used Lemma 8.7.2. Hence there exists a couple of vertical geodesic segments V_1^X and V_2^X of $VD_i^X \setminus (F_1^X \cup F_2^X)$ diverging quickly from each other. Furthermore we have $\eta^Y(E_i^Y(v^X)) < \theta^{\frac{1}{4}}\eta^Y(VD_i^Y)$, hence there exists segments V_1^Y and V_2^Y such that $(V_1^X, V_1^Y) \in V_{\mathcal{B}}^g(D_M(a_1))$ and $(V_2^X, V_2^Y) \in V_{\mathcal{B}}^g(D_M(a_2))$. Let us define $b_i^X = V_i^X(h(a_1) - \frac{1}{2}d(a_1^X, a_2^X))$, so that b_1^X and b_2^X are at the height where V_1^X and V_2^X diverge. Then let us define $b_1^Y = b_2^Y = V_1^Y(-h(a_1) + \frac{1}{2}d(a_1^X, a_2^X))$ and $\gamma_{ij} = (V_i^X, V_j^Y)$ to ensure that the vertical geodesic segments of the quadrilateral $\gamma_{11} \cup \gamma_{12} \cup \gamma_{22} \cup \gamma_{21}$ have close endpoints. Furthermore by construction, they diverge from each other and have ε -monotone image under Φ . \square

In the next proofs, we will be using Proposition 7.1.4 on each of the four images $\Phi(\gamma_{ij})$, which will provide us with a new quadrilateral $(\varepsilon + \theta)R$ close to $\Phi(\gamma_{11} \cup \gamma_{12} \cup \gamma_{22} \cup \gamma_{21})$ on which the assumptions of Lemma 7.3.2 are verified.

Finally we deduce that on a good box, the quasi-isometry Φ is close to a product map.

Proof of Theorem 9.2.1. Let $i \in I_g$ and \mathcal{B}_i a good box (defined in Lemma 9.1.2). Then following Lemma 9.1.2, we have $\eta_i(V^b\mathcal{B}_i) \leq \theta\eta_i(V\mathcal{B}_i)$. Therefore by Lemma 9.1.3, one of the two following statements hold:

1. $\eta(V^\uparrow\mathcal{B} \cap V^g\mathcal{B}) \geq (1 - 3\sqrt{\theta})\eta(V\mathcal{B})$
2. $\eta(V^\downarrow\mathcal{B} \cap V^g\mathcal{B}) \geq (1 - 3\sqrt{\theta})\eta(V\mathcal{B})$

Let us first assume that the dominant orientation is upward. Let us choose $V_1 = V\mathcal{B} \setminus (V^\uparrow\mathcal{B} \cap V^g\mathcal{B})$, the vertical geodesics which have neither dominant orientation nor ε -monotone image by Φ . By Lemma 8.7.3, used with $\alpha := \theta^2$, we have that there exists $U_i \subset \mathcal{B}_i$ such that:

1. $\lambda(U_i) \geq (1 - \sqrt{\theta})\lambda(\mathcal{B}_i)$
2. For $p \in U_i$ we have $\eta(V_1(D_{M_0}(x))) > \eta(V\mathcal{B}(D_{M_0}(x)))\sqrt{\theta}$.

Let us apply Lemma 8.7.7 with $U := U_i$ and $\alpha := \sqrt{\theta}$, then there exists $U' \subset U_i$ of almost full measure such that $\forall z \in h(U')$, $\exists(x_{0,z}, y_{0,z}) \in \mathcal{B}_z$ such that $\forall(x_1, y_1) \in U'_z$, we have $(x_1, y_{0,z}) \in U'$ and $(x_{0,z}, y_1) \in U'$. Let $a, a_0 \in U'$ such that $a^X = a_0^X$. By Lemma 9.2.2 applied on a_0 and a , there exist $b_1, b_2 \in \mathcal{B}_i$ and four vertical geodesics V_{ij} in $V^\uparrow\mathcal{B} \cap V^g\mathcal{B}$ such that b_1 and b_2 form a coarse vertical quadrilateral T with a_0 and a , where V_{ij} are the edges of T . Proposition 7.1.4 gives a constant $M(k, c, \varkappa)$ and four vertical geodesic segments $M\varepsilon R$ -close to the four sides of $\Phi(T)$. Furthermore we assumed that the dominant orientation is upward, hence the images of the four sides are all upward oriented. Hence thanks to Proposition 7.3.2 we get

$$d_X(\Phi(a_0)^X, \Phi(a)^X) \leq_{k,c,\varkappa} \varepsilon R$$

Then for all $a \in U'$ such that $a^X = a_0^X$

$$d_X(\Phi(a_0)^X, \Phi(a)^X) \leq_{k,c,\varkappa} \varepsilon R \quad (9.12)$$

We show similarly that for all $a \in U'$ such that $a^Y = a_0^Y$ we have

$$d_Y(\Phi(a_0)^Y, \Phi(a)^Y) \leq_{k,c,\varkappa} \varepsilon R. \quad (9.13)$$

Let us define the product map $\hat{\Phi}_i := (\hat{\Phi}_i^X, \hat{\Phi}_i^Y) : X \rtimes Y \rightarrow X \rtimes Y$. For all $z \in h(U')$, let $(x_{0,z}, y_{0,z}) \in U'_z$ be the points involved in Lemma 8.7.7 and for all $z \in [0, R] \setminus h(U')$, let us fix an arbitrary point $(x_{0,z}, y_{0,z}) \in (\mathcal{B}_i)_z$. We can therefore define for all $x \in X$

$$\hat{\Phi}_i^X(x) := V_{\Phi(x, y_{0,z})}^X(h \circ \Phi(x_{0,z}, y_{0,z})).$$

Then for all $(x, y) \in U'$ the triangle inequality gives

$$\begin{aligned} d_X(\hat{\Phi}_i^X(x), \Phi(x, y)^X) &= d_X(V_{\Phi(x, y_{0,z})}^X(h \circ \Phi(x_{0,z}, y_{0,z})), \Phi(x, y)^X) \\ &\leq d_X(V_{\Phi(x, y_{0,z})}^X(h \circ \Phi(x_{0,z}, y_{0,z})), \Phi(x, y_{0,z})^X) + d_X(\Phi(x, y_{0,z})^X, \Phi(x, y)^X) \end{aligned} \quad (9.14)$$

Furthermore, as the distance between two points of the same vertical geodesics is equal to their difference of height, we can write the following equality

$$d_X(V_{\Phi(x, y_{0,z})}^X(h \circ \Phi(x_{0,z}, y_{0,z})), \Phi(x, y_{0,z})^X) = \Delta h(\Phi(x, y_{0,z})^X, \Phi(x_{0,z}, y_{0,z})^X)$$

We combine it with inequality (9.14), and then use the Lipschitz Property of h to get

$$\begin{aligned} d_X(\hat{\Phi}_i^X(x), \Phi(x, y)^X) &\leq \Delta h(\Phi(x, y_{0,z})^X, \Phi(x_{0,z}, y_{0,z})^X) + d_X(\Phi(x, y_{0,z})^X, \Phi(x, y)^X) \\ &\leq d_X(\Phi(x, y_{0,z})^X, \Phi(x_{0,z}, y_{0,z})^X) + d_X(\Phi(x, y_{0,z})^X, \Phi(x, y)^X) \\ &\leq_{k,c,\varkappa} 2\varepsilon R, \quad \text{by inequality (9.12)}. \end{aligned}$$

Similarly, $\hat{\Phi}_i^Y(y)$ is defined by

$$\hat{\Phi}_i^Y(y) := V_{\Phi(x_{0,z}, y)}^Y(h \circ \Phi(x_{0,z}, y_{0,z})).$$

and we show similarly that $d_Y(\hat{\Phi}_i^Y(y), \Phi(x, y)^Y) \leq_{k,c,\varkappa} \varepsilon R$. Furthermore for all $(x, y) \in U_i$ we have $h(\hat{\Phi}_i^X(x)) = -h(\hat{\Phi}_i^Y(y))$, hence $\hat{\Phi}_i := (\hat{\Phi}_i^X, \hat{\Phi}_i^Y) : X \rtimes Y \rightarrow X \rtimes Y$ is a well defined product map. Then we chose $U'_i := U'$ to conclude the proof.

The downward orientation case is dealt in the same way by switching the definitions of $\hat{\Phi}_i^X$ and $\hat{\Phi}_i^Y$. \square

9.3 Shadows and orientation

We use the fact that $m > n$ to prove that Φ is orientation preserving, hence the upward orientation is dominant, on each good box at scale R .

Proposition 9.3.1. *Assume that $m > n$. For $R \geq_{\aleph} \frac{1}{\theta}$ the product map $\hat{\Phi}_i$ of Theorem 9.2.1 is orientation preserving for each $i \in I_g$.*

We recall that given a box \mathcal{B} , the shadow of a subset $U \subset \mathcal{B}$, we denote by $Sh(U)$, the set of points of \mathcal{B} below U in the following sens:

$$Sh(U) := \{p \in \mathcal{B} \mid \exists V \in V\mathcal{B} \text{ containing } p \text{ and intersecting } U \text{ on a point } p' \text{ such that } h(p') \geq h(p)\}.$$

And we remind the reader that given a subset $S \subset X$, the large Y -horosphere given by S and denote by $H_S \subset X \rtimes Y$, is the set

$$H_S := S \rtimes Y$$

Let us denote $\mathcal{B} = \mathcal{B}_i$ for $i \in I_g$. Thanks to Theorem 9.2.1, there exist $U = U_i$ with $\lambda(U) \geq (1 - \theta^{\frac{1}{4}})$. We consider two parameters ρ_1 and ρ_2 with $1 \geq_{\aleph} \rho_2 \geq_{\aleph} \rho_1 \geq_{\aleph} \theta^{\frac{1}{16}}$. The relations between them will be specified later. Hence Lemma 8.7.5 applies with $\alpha = \theta^{\frac{1}{4}}$, and it gives us a Y -horosphere H_{x_0} such that

$$\lambda\left(Sh(H_{D_{M_0}(x_0)}) \cap U^c\right) > \theta^{\frac{1}{16}} \lambda\left(Sh(H_{D_{M_0}(x_0)})\right)$$

Then we apply twice Lemma 8.7.6 with $\alpha = \theta^{\frac{1}{4}}$, and $\rho = \rho_i$ for $i \in \{1, 2\}$ to get two planes P_1 and P_2 such that for $i \in \{1, 2\}$

$$\lambda_{h(P_i)}(P_i \cap Sh(H_{D_{M_0}(x_0)}) \cap U^c) \leq_{\aleph} \theta^{\frac{1}{16}} \lambda_{h(P_i)}(P_i \cap Sh(H_{D_{M_0}(x_0)})),$$

and such that $\rho_i R < \Delta h(P_i, H_{x_0}) < 2\rho_i R$.

The next lemma will gives us the existence of two subsets below a Y -horosphere H , which are sufficiently big (for the measure μ in comparison to the horosphere) and sufficiently apart from each other so that any path linking them must get close to H .

Lemma 9.3.2. *Let $M_1(k, c, \aleph)$ be a constant depending on k, c and the metric measured spaces $X \rtimes Y$. In the settings above, for $R \geq_{\aleph} \frac{1}{\rho_2}$, there exist S_1 and S_2 , two subsets of $P_2 \cap \mathcal{B}$ such that for $j \in \{1, 2\}$ we have:*

1. $\forall s_1 \in S_1, s_2 \in S_2, d_X(s_1^X, s_2^X) \geq \rho_2 R$.
2. $\lambda_{h(P_2)}(S_j \cap U^c) \leq_{\aleph} \theta^{\frac{1}{32}} \lambda_{h(P_2)}(S_j)$.
3. $\mu_{h(P_2)}(S_j) \geq_{\aleph} \exp\left(\frac{m-n}{2} \rho_2 R\right) \mu_{h(H)}(\mathcal{N}_{M_0}(H))$.
4. Any path γ joining S_1 and S_2 of length $l(\gamma) \leq M_1 \rho_2 R$ intersects $\mathcal{N}_{6\rho_1 R}(H)$.

Proof. For $j \in \{1, 2\}$, let us denote by $Q_j := P_j \cap Sh(H_{D_{M_0}(x_0)})$. We tile Q_1^X with the top of boxes as in a box tiling. More precisely, let M_0 be the constant involved in assumption (E2), and let $Z \subset Q_1^X$ be an $2M_0$ -maximal separating set of Q_1^X . Then there exists a set of disjoint cells $\{\mathcal{C}(x) \mid x \in Z\}$ such that:

1. $\forall x \in Z, D(x, M_0) \subset \mathcal{C}(x) \subset D(x, 2M_0)$
2. $Q_1^X = \bigcup_{x \in Z} \mathcal{C}(x)$

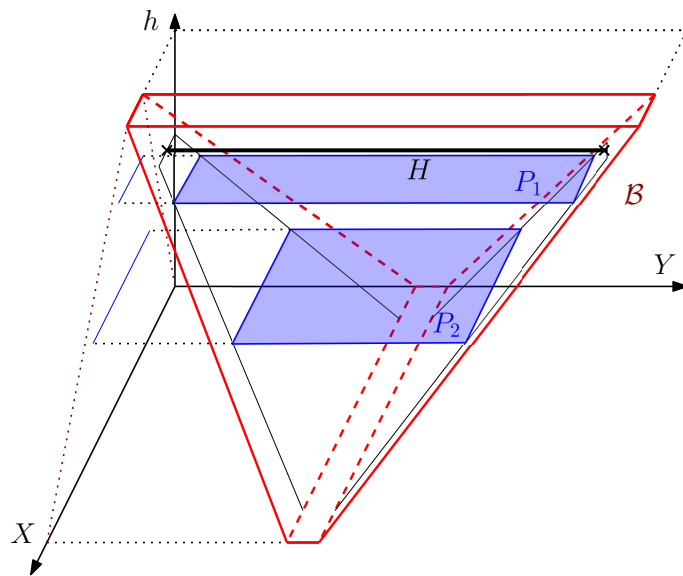

Figure 9.1: Configuration of Lemma 9.3.2

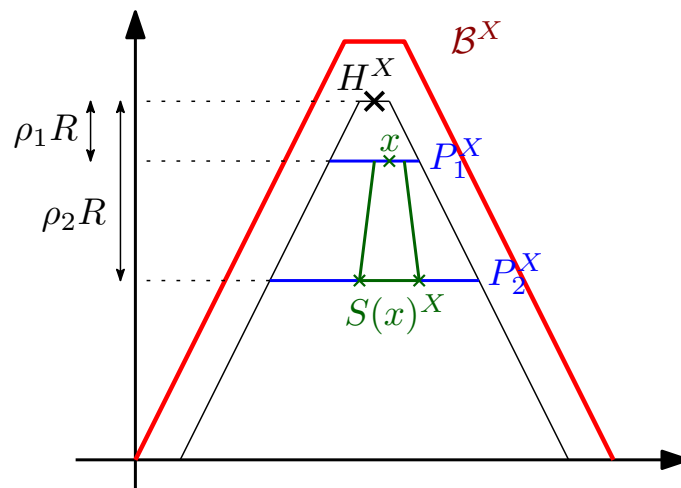

Figure 9.2: Construction of $S(x)^X$ in Lemma 9.3.2

Thanks to this tessellation, we tile Q_1 with the large horosphere $H_{\mathcal{C}(x)} := \mathcal{C}(x) \times \mathcal{B}_{-h(P_1)}^Y = \mathcal{C}(x) \times Q_1^Y$. Furthermore for any two points $x_1, x_2 \in Z$

$$\begin{aligned} \lambda_{h(P_1)}\left(H_{\mathcal{C}(x_1)}\right) &= \lambda_{h(P_1)}^X(\mathcal{C}(x_1))\lambda_{-h(P_1)}^Y\left(\mathcal{B}_{-h(P_1)}^Y\right) \\ &\simeq_{\kappa} \lambda_{h(P_1)}^X(\mathcal{C}(x_2))\lambda_{-h(P_1)}^Y\left(\mathcal{B}_{-h(P_1)}^Y\right), \quad \text{by Lemma 8.1.2} \\ &= \lambda_{h(P_1)}\left(H_{\mathcal{C}(x_2)}\right) \end{aligned}$$

Therefore $\lambda(Q_1) \simeq_{\kappa} \lambda^Y(Q_1^Y) \# Z$. We tile Q_2 by projections of the tessellation of Q_1 , these projections look like stripes on Q_2

$$Q_2 = \bigsqcup_{x \in Z} \pi_{h(P_2)}^X(\mathcal{C}(x)) \times \mathcal{B}_{-h(P_2)}^Y \quad (9.15)$$

Let us denote these stripes by $S(x) := \pi_{h(P_2)}^X(\mathcal{C}(x)) \times \mathcal{B}_{-h(P_2)}^Y$ for all $x \in Z$. For all $x_1, x_2 \in Z$, $d_X(x_1, x_2) \geq M_0$, hence by Lemma 6.0.2 $\forall (s_1^X, s_1^Y) \in S(x_1)$ and $\forall (s_2^X, s_2^Y) \in S(x_2)$ we have

$$d_X(s_1^X, s_2^X) \geq 2\Delta h(P_1, P_2) - M_0 = 2\rho_2 R - 2\rho_1 R - M_0 - M \quad (9.16)$$

$$\geq 2(\rho_2 - 2\rho_1)R, \quad \text{for } R \geq \frac{2(M_0 + M)}{\rho_1}. \quad (9.17)$$

Furthermore we have by construction that

$$\lambda_{h(P_2)}^X\left(\pi_{h(P_2)}^X(\mathcal{C}(x_1))\right) \simeq_{\kappa} \lambda_{h(P_2)}^X\left(\pi_{h(P_2)}^X(\mathcal{C}(x_2))\right)$$

Therefore $\lambda_{h(P_2)}(S(x_1)) \simeq_{\kappa} \lambda_{h(P_2)}(S(x_2))$, and by the tessellation (9.15), $\lambda_{h(P_2)}(Q_2) \simeq_{\kappa} \lambda_{h(P_2)}^Y(Q_2^Y) \# Z$. By Lemma 8.7.6 used with $\alpha := \theta^{\frac{1}{4}}$, we get

$$\lambda_{h(P_2)}(Q_2 \cap U^c) \leq_{\kappa} \theta^{\frac{1}{16}} \lambda_{h(P_2)}(Q_2).$$

Moreover, for all $x_1, x_2 \in Z$ we have $\lambda_{h(P_2)}(S(x_1)) \simeq_{\kappa} \lambda_{h(P_2)}(S(x_2))$ and the set of stripes $S(x)$ for $x \in Z \setminus (Z_1^X)$ tile the set Q_2 . Therefore there exists $Z' \subset Z$ such that $\#Z' \geq \left(1 - \theta^{\frac{1}{32}}\right) \#Z$ and such that for all $x \in Z'$ we have $\lambda_{h(P_2)}(S(x) \cap U^c) \leq \theta^{\frac{1}{32}} \lambda_{h(P_2)}(S(x))$.

We are now able to define S_1 and S_2 . Let $x_1, x_2 \in Z$ be distinct and, for $j \in \{1, 2\}$, let us denote by S_j the following subset of $S(x_j)$

$$S_j := \pi_{h(P_2)}^X(\mathcal{C}(x_j)) \times \text{Int}_{M\rho_2 R}\left(\mathcal{B}_{-h(P_2)}^Y\right) \quad (9.18)$$

By Lemma 8.1.3 applied with $r = M\rho_2 R$, $z_0 = -h^- \mathcal{B}$ and $z_1 = -h(P_2)$, we have $\mu_{h(P_2)}^Y\left(\mathcal{B}_{-h(P_2)}^Y\right) \simeq_{\kappa} \mu_{h(P_2)}^Y\left(\text{Int}_{M\rho_2 R}\left(\mathcal{B}_{-h(P_2)}^Y\right)\right)$, therefore

$$\mu_{h(P_2)}(S_j) \simeq_{\kappa} \mu_{h(P_2)}(S(x_j)) \quad (9.19)$$

The first point of the Lemma holds by inequality (9.17), and the second point holds because we choose x_1 and x_2 in Z' .

Let us now prove the third point. Let $y_0 \in Y$ the nucleus of the cell of \mathcal{B}^Y , we have $\mathcal{B}_{-z}^Y := \pi_{-z}^Y(\mathcal{C}(y_0))$. Then by Lemma 6.0.6 applied with $p = y_0$, $z_0 = h^+$ and $z = h(H) - \rho_2 R$ we have

$$D_{2|h^- - h(P_2)| - M_0}(\pi_{-h(P_2)}^Y(y_0)) \subset \mathcal{B}_{-h(P_2)}^Y \subset D_{2|h^- - h(P_2)| + M_0}(\pi_{-h(P_2)}^Y(y_0))$$

It follows that for $x \in Z$

$$\begin{aligned} & \pi_{h(P_2)}^X(\mathcal{C}(x)) \times D_{2(|h^- - h(H)| - \rho_2 R) - M_0}^Y(\pi_{-h(P_2)}^Y(y_0)) \subset S(x) \\ & \subset \pi_{h(P_2)}^X(\mathcal{C}(x)) \times D_{2(|h^- - h(H)| - \rho_2 R) + M_0}^Y(\pi_{-h(P_2)}^Y(y_0)) \end{aligned}$$

By Lemma 6.0.6, $\pi_{h(P_2)}^X(\mathcal{C}(x))$ resembles a disk of radius $2|h(P_1) - h(P_2)| \pm M_0 = 2(\rho_2 - \rho_1)R \pm M_0$. Lemma 8.1.2 gives $\mu_{h(P_2)}^X(\pi_{h(P_2)}^X(\mathcal{C}(x))) \asymp e^{m(\rho_2 - \rho_1)R}$. Again by Lemma 8.1.2 applied on

$$D_{2(|h^- - h(H)| - \rho_2 R) + M_0}^Y(\pi_{-h(P_2)}^Y(y_0)),$$

we have

$$\mu_{h(P_2)}(S(x)) \asymp_{\mathfrak{K}} e^{m(\rho_2 - \rho_1)R} e^{n(|h^- - h(H)| - \rho_2 R)}$$

Similarly Q_2 resembles a product $D_{2\rho_2 R \pm M_0} \times B_{-h(P_2)}^Y$, hence

$$\mu_{h(P_2)}(Q_2) \asymp_{\mathfrak{K}} e^{m\rho_2 R} e^{n(|h^- - h(H)| - \rho_2 R)}.$$

Therefore we obtain an estimate of $\#Z$

$$\frac{\mu_{h(P_2)}(Q_2)}{\mu_{h(P_2)}(S(x))} \asymp_{\mathfrak{K}} e^{m\rho_1 R}. \quad (9.20)$$

Applying Lemma 8.8.2 with $A = Q_2$, $U = \mathcal{N}_{M_0}(H)$ and $\Delta = \rho_2 R$ gives

$$\mu_{h(P_2)}(Q_2) \geq_{\mathfrak{K}} \exp((m - n)\rho_2 R) \mu_{h(H)}(\mathcal{N}_{M_0}(H)).$$

In combination with inequalities (9.19) and (9.20) we have for $j \in \{1, 2\}$

$$\begin{aligned} \mu_{h(P_2)}(S_j) & \geq_{\mathfrak{K}} \exp((m - n)\rho_2 R - m\rho_1 R) \mu_{h(H)}(\mathcal{N}_{M_0}(H)) \\ & \geq_{\mathfrak{K}} \exp\left(\frac{m - n}{2}\rho_2 R\right) \mu_{h(H)}(\mathcal{N}_{M_0}(H)), \end{aligned}$$

where the last inequality holds since $(m - n)\rho_2 - m\rho_1 \geq \frac{m - n}{2}\rho_2$ when $\rho_1 \leq \frac{m - n}{m}\rho_2$. Therefore the third conclusion of this Lemma holds.

Let us prove the fourth conclusion. Let γ be a path joining $s_1 \in S_1$ and $s_2 \in S_2$ such that $l(\gamma) \leq M\rho_2 R$. By inequality (9.17), $d_X(s_1^X, s_2^X) \geq 2\rho_2 R - 4\rho_1 R$. By Lemma 3.1.2 there exists a constant $M'(\delta)$ such that the geodesic segment $[s_1^X, s_2^X]$ contains a point s_3^X within $4\rho_1 R - M'(\delta) \leq 5\rho_1 R$ of $H^X = \{x_0\}$, for $R \geq \frac{M'(\delta)}{\rho_1}$. Therefore by Proposition 3.2.1

$$l(\gamma^X) \geq 2^{\delta d_X(\gamma^X, s_3^X)}.$$

However, every δ -hyperbolic space with $\delta \leq 1$ is also 1-hyperbolic. Therefore we can assume without loss of generality that $\delta \geq 1$. Then we have

$$l(\gamma^X) \geq 2^{d_X(\gamma^X, s_3^X)} \geq 2^{d_X(\gamma^X, H^X) - 5\rho_1 R}.$$

Hence $\log_2(M\rho_2 R) \geq d(\gamma^X, H^X) - 5\rho_1 R$. Furthermore, there exists $M'(k, c, \mathfrak{K})$ such that for $R \geq \frac{M'}{\rho_2}$ we have $\log_2(M\rho_2 R) \leq \rho_1 R$. In this case

$$d(\gamma^X, H^X) \leq 6\rho_1 R$$

Therefore there exists $t \in \mathbb{R}$ such that $\Delta h(\gamma(t), H) \leq 6\rho_1 R$. Let us now look at γ^Y . Two cases arise, we have either $\gamma^Y(t) \in \text{Sh}(\mathcal{B}_{-h(P_2)}^Y)$ or $\gamma^Y(t) \notin \text{Sh}(\mathcal{B}_{-h(P_2)}^Y)$.

In the first case, there exists $y \in H^Y$ such that $\gamma^Y(t) \in V_y$. Furthermore $\Delta h(\gamma(t), H) \leq 6\rho_1 R$, hence $d_Y(\gamma^Y(t), H^Y) = \Delta h(\gamma^Y(t), H^Y) \leq 6\rho_1 R$ and consequently $d_Y(\gamma^Y, H^Y) \leq 6\rho_1 R$. Which proves $d(\gamma, H) \leq 6\rho_1 R$.

In the second case, when $\gamma^Y(t) \notin \mathcal{B}_{-h(P_2)}^Y$, by our claim (9.18) we have that the vertical geodesic ray $V_{\gamma^Y(t)}$ starting at $\gamma^Y(t)$ intersect $Y_{-h(P_2)}$ in a point y such that $d_Y(y, S_1^Y \cup S_2^Y) > M\rho_2 R$. Therefore

$$\begin{aligned} M\rho_2 R &\geq l(\gamma) \geq \frac{1}{2}l(\gamma^Y) \geq \frac{1}{2}(d(s_1, \gamma(t)) + d(\gamma(t), s_2)) \\ &> \frac{2M\rho_2 R}{2} > M\rho_2 R, \end{aligned}$$

which is absurd, hence the second case when $\gamma^Y(t) \notin \mathcal{B}_{-h(P_2)}^Y$ does not occur. Therefore we always have that γ intersect the $6\rho_1 R$ -neighbourhood of H . \square

Proof of Proposition 9.3.1. Let us be in the settings above. Let us assume by contradiction that $\hat{\Phi}$ is orientation reversing, which means that there exists $\hat{\Phi}^X : X \rightarrow Y$ and $\hat{\Phi}^Y : Y \rightarrow X$ such that for all $(x, y) \in \mathcal{B}$ we have $\hat{\Phi}(x, y) = (\hat{\Phi}^Y(y), \hat{\Phi}^X(x))$.

For all $p \in X \bowtie Y$ such that $d_{\bowtie}(p, \hat{\Phi}(H \cap U)) \leq \rho_1 R$ there exists $q \in H \cap U$ such that $d(p, \hat{\Phi}(q)) \leq \rho_1 R$. Therefore by the triangle inequality

$$\begin{aligned} d(p, \Phi(q)) &\leq d(p, \hat{\Phi}(q)) + d(\hat{\Phi}(q), \Phi(q)) \leq_{k,c,\bowtie} \rho_1 R + \varepsilon R, \quad \text{by Theorem 9.2.1 since } q \in U, \\ &\leq_{k,c,\bowtie} \rho_1 R, \quad \text{since } \varepsilon \leq \rho_1. \end{aligned}$$

Hence there exists $M(k, c, \bowtie)$ such that $\mathcal{N}_{\rho_1 R}(\hat{\Phi}(H \cap U)) \subset \mathcal{N}_{M\rho_1 R}(\Phi(H \cap U))$. We show similarly that for $j \in \{1, 2\}$

$$\mathcal{N}_{\rho_1 R}(\Phi(S_j \cap U)) \subset \mathcal{N}_{M\rho_1 R}(\hat{\Phi}(S_j \cap U)). \quad (9.21)$$

Let $M'(\bowtie)$ be the constant involved in Corollary 8.5.4. Then

$$\begin{aligned} \mu(\mathcal{N}_{8k\rho_1 R}(\Phi(H))) &\leq_{k,c,\bowtie} e^{8k\rho_1 Rm} \mu(\mathcal{N}_{kc+c}(\Phi(H))), \quad \text{by Corollary 8.5.3,} \\ &\leq_{k,c,\bowtie} e^{8k\rho_1 Rm} \mu(\mathcal{N}_1(H)), \quad \text{by Lemma 8.5.5,} \\ &\leq e^{8k\rho_1 Rm} \mu(\mathcal{N}_{M'}(H)) \\ &\lesssim_{\bowtie} e^{8k\rho_1 Rm} \mu_{h(H)}(\mathcal{N}_{M'}(H)), \quad \text{by the second part of Lemma 8.5.4,} \\ &\leq_{\bowtie} e^{8k\rho_1 Rm} \mu_{h(H)}(\mathcal{N}_{M_0}(H)), \quad \text{by the first part of Lemma 8.5.4.} \end{aligned}$$

Combined with 2. of Lemma 9.3.2 we have

$$\begin{aligned} \mu(\mathcal{N}_{8k\rho_1 R}(\Phi(H))) &\leq_{\bowtie} e^{-(m-n)\frac{\rho_2}{2}R} e^{8k\rho_1 Rm} \mu_{h(P_2)}(S_j) \\ &\leq_{\bowtie} e^{-(m-n)\frac{\rho_2}{2}R} e^{8k\rho_1 Rm} \mu_{h(P_2)}(S_j \cap U), \quad \text{thanks to 2. of Lemma 9.3.2,} \\ &\leq_{\bowtie} e^{-(m-n)\frac{\rho_2}{4}R} \mu_{h(P_2)}(\mathcal{N}_1(S_j \cap U)), \quad \text{since } \rho_1 \leq \frac{\rho_2}{M}, \\ &\lesssim_{\bowtie} e^{-(m-n)\frac{\rho_2}{4}R} \mu(\mathcal{N}_{M'}(S_j \cap U)), \quad \text{by Lemma 8.5.4,} \\ &\leq e^{-(m-n)\frac{\rho_2}{4}R} \mu(\mathcal{N}_{M'+kc+c}(S_j \cap U)) \end{aligned}$$

Hence using Lemma 8.5.5 on $\mathcal{N}_{M'}(S_j \cap U)$

$$\begin{aligned}
\mu(\mathcal{N}_{8k\rho_1 R}(\Phi(H))) &\leq_{k,c,\varkappa} e^{-(m-n)\frac{\rho_2}{4}R} \mu(\mathcal{N}_{M'+1}(\Phi(S_j \cap U))) \\
&\leq e^{-(m-n)\frac{\rho_2}{4}R} \mu(\mathcal{N}_{\rho_1 R}(\Phi(S_j \cap U))), \quad \text{for } R \geq \frac{M'}{\rho_1}, \\
&\leq e^{-(m-n)\frac{\rho_2}{4}R} \mu(\mathcal{N}_{M\rho_1 R}(\hat{\Phi}(S_j \cap U))), \quad \text{by inequality (9.21)} \\
&\leq_{k,c,\varkappa} e^{-(m-n)\frac{\rho_2}{4}R} e^{M\rho_1 R m} \mu(\mathcal{N}_{M'}(\hat{\Phi}(S_j \cap U))), \quad \text{by Lemma 8.5.4,} \\
&\leq_{k,c,\varkappa} e^{-(m-n)\frac{\rho_2}{8}R} \mu(\mathcal{N}_{M'}(\hat{\Phi}(S_j \cap U))), \quad \text{since } \rho_1 \leq \frac{\rho_2}{M}, \\
&\asymp_{k,c,\varkappa} e^{-(m-n)\frac{\rho_2}{8}R} \mu_{\hat{z}_0}(\mathcal{N}_{M'}(\hat{\Phi}(S_j \cap U))), \quad \text{by the first part of Lemma 8.5.4.}
\end{aligned}$$

where $\hat{z}_0 := \hat{\Phi}(P_2)$. Since $\hat{\Phi}$ is orientation reversing, we can now apply Lemma 8.8.3 with $A_j = \hat{\Phi}(S_j \cap U)$, $E = \mathcal{N}_{8k\rho_1 R}(\Phi(H))$ and $Q = e^{(m-n)\frac{\rho_2}{8}R}$ we have that

$$\eta(V\mathcal{N}_{M_0}(\hat{\Phi}(S_j \cap U))) \geq_{k,c,\varkappa} e^{(m-n)\frac{\rho_2}{8}R} \eta(V\mathcal{N}_{M_0}(E)).$$

Then, as pointed out below Lemma 8.7.3, we can apply it on a A_j with $V_1 = VE$. Hence there exist $U_{A_j} \subset A_j$ such that:

- $\lambda_{\hat{z}_0}(U_{A_j}) \geq (1 - e^{(m-n)\frac{\rho_2}{8}R})\lambda_{\hat{z}_0}(A_j)$.
- For all $p \in U$, most of the vertical geodesic in $D_{M_0}(p)$ do not intersect E .

By Property 8.6.5 we have

$$\lambda_{\hat{z}_0}(\mathcal{N}_{M_0}(\hat{\Phi}(S_j \cap U))) \geq_{k,c,\varkappa} e^{(m-n)\frac{\rho_2}{8}R} \lambda_{\hat{z}_0}(\pi_{\hat{z}_0}^{\varkappa}(\mathcal{N}_{M_0}(E))).$$

Hence by the definition of $\lambda_{\hat{z}_0}$

$$\mu_{\hat{z}_0}(\mathcal{N}_{M_0}(\hat{\Phi}(S_j \cap U))) \geq_{k,c,\varkappa} e^{(m-n)\frac{\rho_2}{8}R} \mu_{\hat{z}_0}(\pi_{\hat{z}_0}^{\varkappa}(\mathcal{N}_{M_0}(E))). \quad (9.22)$$

Let us denote $E' := \mathcal{N}_{M_0}(\hat{\Phi}(S_j \cap U) \setminus U_{A_j})$. Since $\hat{\Phi}$ is $M\varepsilon R$ -close to Φ on U by Theorem 9.2.1, we have (similarly as in inequality 9.21) that

$$\mathcal{N}_{\rho_1 R}(\hat{\Phi}^{-1}(E')) \subset \mathcal{N}_{M\rho_1 R}(\Phi^{-1}(E'))$$

Therefore

$$\begin{aligned}
\mu(\mathcal{N}_{\rho_1 R}(\hat{\Phi}^{-1}(E'))) &\leq_{k,c,\varkappa} \mu(\mathcal{N}_{M\rho_1 R}(\Phi^{-1}(E'))) \\
&\leq_{k,c,\varkappa} e^{6M\rho_1 R m} \mu(\mathcal{N}_{k+c}(\Phi^{-1}(E'))), \quad \text{by the first part of Lemma 8.5.4,} \\
&\asymp_{k,c,\varkappa} e^{6M\rho_1 R m} \mu(\mathcal{N}_1(E')), \quad \text{by Lemma 8.5.5,} \\
&\asymp_{k,c,\varkappa} e^{6M\rho_1 R m} \mu_{\hat{z}_0}(\mathcal{N}_{M_0}(E')), \quad \text{by the second part of Lemma 8.5.4,} \\
&\leq_{k,c,\varkappa} e^{-(m-n)\frac{\rho_2}{8}R} e^{6M\rho_1 R m} \mu_{\hat{z}_0}(\mathcal{N}_{M_0}(\hat{\Phi}(S_j \cap U))), \quad \text{by inequality 9.22,} \\
&\leq_{k,c,\varkappa} e^{(m-n)\frac{\rho_2}{16}R} \mu_{h(P_2)}(\mathcal{N}_{M_0}(S_j \cap U)), \quad \text{since } \rho_1 \leq \frac{\rho_2}{M}, \\
&\leq_{k,c,\varkappa} e^{(m-n)\frac{\rho_2}{16}R} \mu_{h(P_2)}(\mathcal{N}_{M_0}(S_j)), \quad \text{since } S_j \cap U \text{ have almost full measure in } S_j.
\end{aligned}$$

Following the second conclusion of Lemma 9.3.2, there exists a constant $M(\varkappa)$ such that $\lambda_{h(P_2)}(S_j \cap U^c) \leq M\theta^{\frac{1}{32}}\lambda_{h(P_2)}(S_j)$.

We apply twice Lemma 8.7.1 for $j = 1, 2$ with $(V_1, \eta) = (\mathcal{N}_{M_0}(S_j^X) \times \mathcal{N}_{M_0}(S_j^Y), \mu_{h(P_2)})$, $V_0 = U^c \cap$

$\mathcal{N}_{\rho_1 R}(\hat{\Phi}^{-1}(E'))$ and $\alpha := e^{(m-n)\frac{\rho_2}{16}R} \mu_{h(P_2)} + M\theta^{\frac{1}{32}}$. Let us denote $G^Y(p^X) := \{p^Y \in V_1^Y \mid (p^X, p^Y) \in V_0\}$, we have that

$$\mu_{h(P_2)}^X \left(\left\{ p^X \in V_1^X \mid \mu_{-h(P_2)}^Y(G^Y(p^X)) \right\} \right) \geq \left(1 - e^{-(m-n)\frac{\rho_2}{32}R} \right) \mu_{h(P_2)}^Y(V_1^Y).$$

Since $e^{-(m-n)\frac{\rho_2}{32}R} + M\theta^{\frac{1}{32}} < \frac{1}{2}$, there exists $s_1 \in (S_1 \cap U) \setminus \hat{\Phi}^{-1}(E')$ and $s_2 \in (S_2 \cap U) \setminus \hat{\Phi}^{-1}(E')$ such that $s_1^Y = s_2^Y$.

Let us denote by $\hat{s}_j := \Phi(s_j(h(P_2)))$ for $j \in \{1, 2\}$. By construction we have $\hat{s}_j \in A_j$, then $VD_{M_0}(s_j)$ contains almost only vertical geodesic segments which do not intersect E . Since $\hat{s}_1^X = \hat{s}_2^X$, and by Lemma 8.7.2 we can find two vertical geodesics $v_1 \in VD_{M_0}(s_1)$ and $v_2 \in VD_{M_0}(s_2)$ which do not intersect $E = \mathcal{N}_{8k\rho_1 R}(\Phi(H))$, and such that $s_1^X = s_2^X$. Since v_1^Y and v_2^Y meet (up to an additive constant) at the height $-\hat{z}_0 + \frac{1}{2}d_Y(\hat{s}_1, \hat{s}_2)$, there exist $M(\delta)$ such that the concatenation of v_1 and v_2 is $(1, M(\delta))$ -quasigeodesic linking \hat{s}_1 to \hat{s}_2 .

Let us denote by $\gamma := \Phi^{-1}(v_1 \cup v_2)$, then γ is a $(k, c + M)$ -quasigeodesic. By Lemma 2.1 of [17], there exists a $2k$ -Lipschitz, $(k, 4(M + c))$ -quasi-geodesic γ' in the $2(M + c)$ -neighbourhood of γ , linking $\Phi^{-1}(\hat{s}_1)$ to $\Phi^{-1}(\hat{s}_2)$. Let us denote $s'_1 = \Phi^{-1}(\hat{s}_1)$ and $s'_2 = \Phi^{-1}(\hat{s}_2)$. Because γ' is $2k$ -Lipschitz, and since Φ^{-1} is a (k, c) -quasi-isometry we have

$$l(\gamma') \leq 2kd_{\mathfrak{M}}(\hat{s}_1, \hat{s}_2) \leq k^2 d_{\mathfrak{M}}(s'_1, s'_2) + c \tag{9.23}$$

Furthermore, γ' does not intersect the $\frac{1}{k}(7k\rho_1 R - 2c) - c$ -neighbourhood of H since Φ^{-1} is a quasi-isometry. Moreover s'_j and s_j are εR close to each other, that is

$$\begin{aligned} d_{\mathfrak{M}}(s'_j, s_j) &= d_{\mathfrak{M}}(\Phi^{-1}(\hat{\Phi}(s_j)), s_j) \\ &\leq kd_{\mathfrak{M}}(\hat{\Phi}(s_j), \Phi(s_j)) \leq_{k,c,\mathfrak{M}} \varepsilon R, \quad \text{since } s_j \in U. \end{aligned} \tag{9.24}$$

Consequently by the triangle inequality we get

$$\begin{aligned} d_{\mathfrak{M}}(s'_1, s'_2) &\leq d_{\mathfrak{M}}(s'_1, s_1) + d_{\mathfrak{M}}(s_1, s_2) + d_{\mathfrak{M}}(s_2, s'_2) \\ &\leq_{k,c,\mathfrak{M}} \varepsilon R + d_{\mathfrak{M}}(s_1, s_2), \quad \text{since } \hat{\Phi}^{-1}(s_j) \in U \end{aligned} \tag{9.25}$$

Furthermore $s_1^Y = s_2^Y$, therefore by Corollary 4.3.4, with $M = 15C_0$ we obtain

$$d_{\mathfrak{M}}(s_1, s_2) \leq d_X(s_1^X, s_2^X) + M \leq 2\rho_2 R + M, \quad \text{by the first point of Lemma 9.3.2.}$$

Combined with inequalities (9.23) and (9.25) we get

$$l(\gamma') \leq_{k,c,\mathfrak{M}} 2k^2(2\rho_2 R + M + 2\varepsilon R) + c \leq_{k,c,\mathfrak{M}} \rho_2 R, \quad \text{for } R \geq \frac{M + c}{\rho_2}.$$

For $j \in \{1, 2\}$, let $\gamma_j := [s_j, s'_j]$, by inequality (9.24) we have $l(\gamma_j) \leq_{k,c,\mathfrak{M}} \varepsilon R$. Hence the path γ'' , constructed as the concatenation of γ_1 , γ' and γ_2 , is a path linking $s_1 \in S_1$ to $s_2 \in S_2$, of length $l(\gamma) \leq_{k,c,\mathfrak{M}} \rho_2 R$ since $\varepsilon \leq \rho_2$. Furthermore, by construction, γ'' does not intersect the $7\rho_1 R - 3c - 2M\varepsilon R > 6\rho_1 R$ -neighbourhood of H . This contradicts the fourth point of Lemma 9.3.2 therefore Φ is orientation preserving. \square

9.4 Factorisation of a quasi-isometry in big boxes

In Section 9.2 we proved that for all $i \in I_g$, $\Phi|_{\mathcal{B}_i}$ is close to a quasi-isometry product $\hat{\Phi}_i = (\hat{\Phi}_i^X, \hat{\Phi}_i^Y)$ on a set of almost full measure $U_i \subset \mathcal{B}_i$. In this section we prove that Φ is close to $\hat{\Phi}$ on all boxes at scale L on a set of almost full measure. This is a step-forward since this is true on all boxes at scale L and not only a significant number of them.

Theorem 9.4.1. For $0 < \theta \leq_{k,c,\varkappa} 1$, for $L \geq_{\varkappa} \frac{1}{\theta}$ and for all box \mathcal{B} at scale L , there exists $M(k, c, \varkappa)$, $U \in \mathcal{B}$ and a $(k, M\sqrt{\theta}L)$ -quasi-isometry product map $\hat{\Phi} = (\hat{\Phi}^X, \hat{\Phi}^Y)$ such that:

1. $\lambda(U) \geq \left(1 - \theta^{\frac{1}{8}}\right) \lambda(\mathcal{B})$
2. $d_{\varkappa}(\Phi|_U, \hat{\Phi}|_U) \leq_{\varkappa} \sqrt{\theta}L$

Let \mathcal{B} be a box at scale L , let $i \in I_g$ and for all $i \in I_g$ let $U_i \subset \mathcal{B}_i$ be as in Theorem 9.2.1, where U_i is the subset of \mathcal{B}_i on which Φ is close to a product map $\hat{\Phi}_i$. Let us denote by $W \subset \mathcal{B}$ the "good" set of \mathcal{B}

$$W := \bigsqcup_{i \in I_g} U_i$$

where "good" means the set on which Φ is close to a product maps on boxes at scale R . We introduce the application P which quantifies the portion of a geodesic segment which is not in W .

Definition 9.4.2. Let $\gamma : [0, L] \rightarrow X \varkappa Y$ be a vertical geodesic segment. We denote the measure of points in $\gamma \cap W^c$ by

$$P(\gamma) := \text{Leb}(\gamma^{-1}(W^c)) \quad (9.26)$$

The value of $P(\gamma)$ is related to γ being ε -monotone.

Lemma 9.4.3. For $0 \leq \varepsilon \leq_{k,c,\varkappa} \sqrt{\theta} \leq_{k,c,\varkappa} 1$, there exists $M(\varkappa, k, c)$ such that for all vertical geodesic segments $\gamma : [0, L] \rightarrow X \varkappa Y$ we have

$$P(\gamma) \leq \sqrt{\theta}L \Rightarrow \Phi \circ \gamma \text{ is } M\sqrt{\theta}\text{-monotone.}$$

Proof. Let $t_1, t_2 \in [0, L]$ such that $\Phi(h(\gamma(t_1))) = \phi(h(\gamma(t_2)))$ and such that $t_2 \geq t_1$. Let us decompose $[t_1, t_2]$ into segments of length $\sqrt{\theta}R$. without loss of generality we can assume that $t_2 - t_1 \geq \sqrt{\theta}R$. Let us denote $N := \left\lfloor \frac{t_2 - t_1}{\sqrt{\theta}R} \right\rfloor$, $I_i := [t_1 + i\sqrt{\theta}R, t_1 + (i+1)\sqrt{\theta}R]$ for any $i \in \{0, \dots, N-1\}$ and $I_N := [t_1 + (N-1)\sqrt{\theta}R, t_2]$. We have

$$[t_1, t_2] := \bigsqcup_{i=0}^N I_i$$

Then for all $i \in \{0, \dots, N\}$ let us choose $s_i \in I_i$ such that $\gamma(s_i) \in W$ if possible, and any $s_i \in I_i$ otherwise. Let us denote by J the set of odd indexes in $\{0, \dots, N\}$, we split J into the following sets:

$$\begin{aligned} J_0 &:= \{j \in J \mid \gamma(s_j) \text{ and } \gamma(s_{j+2}) \text{ are both in the same box and in } W\} \\ J_1 &:= \{j \in J \mid \gamma(s_j) \text{ and } \gamma(s_{j+1}) \text{ are in different boxes}\} \\ J'_1 &:= \{j \in J \mid \gamma(s_{j+1}) \text{ and } \gamma(s_{j+2}) \text{ are in different boxes}\} \\ J_2 &:= \{j \in J \mid I_j \subset W^c\} \\ J'_2 &:= \{j \in J \mid I_{j+2} \subset W^c\} \end{aligned}$$

We claim that

$$J = J_0 \sqcup (J_1 \cup J'_1 \cup J_2 \cup J'_2)$$

To prove it, one can see that two cases arise when an odd index j is not in J_0 . The first case is when $\gamma(s_j)$ and $\gamma(s_{j+2})$ are not in the same box, which leads to the fact that either $j \in J_1$ or $j \in J'_1$. The second case happens when $\gamma(s_j)$ or $\gamma(s_{j+2})$ are not in W , which leads to either $I_j \subset W^c$ or $I_{j+2} \subset W^c$. Therefore, we proved that an odd index is either in J_0 or in $J_1 \cup J'_1 \cup J_2 \cup J'_2$.

By the assumption $P(\gamma) \leq \sqrt{\theta}L$, hence we have that $\#J_2 \leq \frac{\sqrt{\theta}L}{\sqrt{\theta}R} = \frac{L}{R}$ and similarly that $\#J'_2 \leq \frac{L}{R}$. Furthermore there are less than $\frac{L}{R}$ boxes intersecting γ , therefore $\#J_1 \leq \frac{t_2-t_1}{R} \leq \frac{L}{R}$ and $\#J'_1 \leq \frac{L}{R}$, hence

$$\begin{aligned} \#(J_1 \cup J'_1 \cup J_2 \cup J'_2) &\leq 4\frac{L}{R} \\ \#J_0 &= \#J - \#(J_1 \cup J'_1 \cup J_2 \cup J'_2) \geq \frac{t_2-t_1}{2\sqrt{\theta}R} - 4\frac{L}{R} \end{aligned}$$

We see that the "good" indexes are in majority compared to the "bad" indexes. We now use that fact to prove that $|t_2 - t_1|$ is smaller than $\sqrt{\theta}L$. Let us denote $q(t) := h \circ \Phi \circ \gamma(t)$ for all $t \in [0, L]$. We assume that N is odd, the case where N is even is treated identically. By assumption $q(t_1) = q(t_2)$ therefore

$$\begin{aligned} 0 &= q(t_1) - q(t_2) = q(t_1) - q(s_1) + \sum_{i \in J} (q(s_i) - q(s_{i+2})) + q(s_N) - q(t_2) \\ &= q(t_1) - q(s_1) + \sum_{i \in J_0} (q(s_i) - q(s_{i+2})) + \sum_{i \in J \setminus J_0} (q(s_i) - q(s_{i+2})) + q(s_N) - q(t_2) \end{aligned} \quad (9.27)$$

However we proved that $\#J_0$ is much bigger than $\#(J \setminus J_0)$, and for any $i \in J_0$, $q(s_i) - q(s_{i+2})$ is a positive number by the upward orientation of the quasi-isometry on W . Therefore we will show that $|t_1 - t_2|$ must be small for this equality to hold. First, we have to consider that $\forall i \in \{0, \dots, N\}$

$$\begin{aligned} l(I_{i+1}) &\leq |s_i - s_{i+2}| \leq l(I_i) + l(I_{i+1}) + l(I_{i+2}) \\ &\Rightarrow \sqrt{\theta}R \leq |s_i - s_{i+2}| \leq 3\sqrt{\theta}R \\ &\Rightarrow |q(s_i) - q(s_{i+2})| \leq_{k,c,\varkappa} \sqrt{\theta}R \end{aligned}$$

Hence for all $i \in J \setminus J_0$ we have $q(s_i) - q(s_{i+2}) \geq_{k,c,\varkappa} -\sqrt{\theta}R$. Furthermore for all $i \in J_0$, s_i and s_{i+2} are in the same box and in W , therefore by Corollary 7.1.5, there exists $M(k, c, \varkappa)$ such that

$$q(s_i) - q(s_{i+2}) \geq \frac{1}{k}|s_i - s_{i+2}| - M\varepsilon R \geq_{k,c,\varkappa} \sqrt{\theta}R; \quad \text{since } \sqrt{\theta} \geq 2M\varepsilon.$$

Combined with equality (9.27)

$$0 \geq_{k,c,\varkappa} \sqrt{\theta}R\#J_0 - \sqrt{\theta}R\#(J_1 \cup J'_1 \cup J_2 \cup J'_2) \geq |t_2 - t_1| - \sqrt{\theta}L$$

Hence $|t_2 - t_1| \leq_{k,c,\varkappa} \sqrt{\theta}L$, which proves that there exists $M(k, c, \varkappa)$ such that γ is $M\sqrt{\theta}$ -monotone. \square

Let M be the constant involved in Lemma 9.4.3, and let $\varepsilon' := 2M\sqrt{\theta}$. Thanks to the previous lemma, we show that almost all vertical geodesic segments of boxes at scale L have ε -monotone images under Φ .

Let us denote by $V^g\mathcal{B} \subset V\mathcal{B}$ the set of vertical geodesic segments of $V\mathcal{B}$ whose image by Φ are ε' -monotone.

Lemma 9.4.4. For $L \geq_{k,c,\varkappa} \frac{1}{\theta}$ and for any box \mathcal{B} at scale L we have that

$$\eta(V^g\mathcal{B}) \geq (1 - \sqrt{\theta})\eta(V\mathcal{B}) \quad (9.28)$$

Proof. Lemma 9.4.3 tells us that $P(\gamma) \geq \sqrt{\theta}L$ for all $\gamma \in V^g\mathcal{B}$. Computing the measure λ of W^c we have

$$\begin{aligned} \lambda(W^c) &= \int_0^L \lambda_z(W_z^c) dz \simeq_{\varkappa} \int_0^L \eta(V_{\mathcal{B}}(W_z^c)) dz, \quad \text{by Proposition 8.6.5,} \\ &\simeq_{\varkappa} \int_0^L \int_{V\mathcal{B}} \mathbb{1}_{V_{\mathcal{B}}(W_z^c)}(\gamma) d\eta(\gamma) dz \simeq_{\varkappa} \int_{V\mathcal{B}} \int_0^L \mathbb{1}_{V_{\mathcal{B}}(W_z^c)}(\gamma) dz d\eta(\gamma), \quad \text{by Fubini Theorem.} \end{aligned} \quad (9.29)$$

However we have

$$\mathbb{1}_{V_{\mathcal{B}}(W_{\varepsilon}^c)}(\gamma) = \begin{cases} 0 & \text{if } z \in \gamma^{-1}(W) \\ 1 & \text{if } z \in \gamma^{-1}(W^c) \end{cases} \quad (9.30)$$

Therefore $\mathbb{1}_{V_{\mathcal{B}}(W_{\varepsilon}^c)}(\gamma) = \mathbb{1}_{\gamma^{-1}(W^c)}(z)$. With inequality (9.29) it gives us

$$\begin{aligned} \lambda(W^c) &\underset{\asymp_{\mathfrak{M}}}{\geq} \int_{V_{\mathcal{B}}} \int_0^L \mathbb{1}_{\gamma^{-1}(W^c)}(z) dz d\eta(\gamma) \geq \int_{V^b \mathcal{B}} \int_0^L \mathbb{1}_{\gamma^{-1}(W^c)}(z) dz d\eta(\gamma), \quad \text{since } V^b \mathcal{B} \subset V_{\mathcal{B}} \\ &\geq \int_{V^b \mathcal{B}} \text{Leb}(\gamma^{-1}(W^c)) d\eta(\gamma) = \int_{V^b \mathcal{B}} P(\gamma) d\eta(\gamma) \end{aligned} \quad (9.31)$$

Let us assume by contradiction that $\eta(V^g \mathcal{B}) < (1 - \sqrt{\theta})\eta(V\mathcal{B})$, hence we have $\eta(V^b \mathcal{B}) > \sqrt{\theta}\eta(V\mathcal{B})$. Therefore by inequality (9.31)

$$\begin{aligned} \lambda(W^c) &\underset{\asymp_{\mathfrak{M}}}{\geq} \eta(V^b \mathcal{B}) \sqrt{\theta} L \geq \sqrt{\theta} \eta(V\mathcal{B}) \sqrt{\theta} L \\ &\underset{\asymp_{\mathfrak{M}}}{\geq} \theta \lambda(\mathcal{B}), \end{aligned}$$

which contradicts Proposition 9.1.2. \square

As in Section 9.2 we deduce that, in boxes which have almost only vertical geodesic segment with $2M\sqrt{\theta}$ -monotone image, Φ is close to a product map. Let us denote $\varepsilon' := 2M\sqrt{\theta}$ and $\theta' := 2M\sqrt{\theta}$, then for $0 < \theta' \leq_{k,c,\mathfrak{M}} 1$ we have that $\theta' \leq \varepsilon' \leq \sqrt{\theta'}$.

Proof of Theorem 9.4.1. The proof is similar to Theorem 9.2.1. The Lemma 9.4.4 plays the role of the second conclusion of Lemma 9.1.2, with ε' instead of ε . In a box at scale L , almost all vertical geodesic segment have ε' -monotone image by Φ .

Then, because $\varepsilon' \leq_{k,c,\mathfrak{M}} \sqrt{\theta'}$, Lemma 9.1.3 provides us with a dominant orientation. In combination with Lemma 8.7.3, we get Lemma 9.2.2, which provides us with the vertical tetrahedrons. Then we make use of them, as in the proof of Theorem 9.2.1 to construct the quasi-isometry product $\hat{\Phi}$.

In a box at scale R , the upper-bound εR on the distance between Φ and $\hat{\Phi}$ is achieved since $\theta \leq \varepsilon$, and in our box at scale L , it is achieved since $\theta' \leq \varepsilon'$. \square

This is a step forward since now, Theorem 9.4.1 holds for all boxes at scale L , and not only a significant proportion of boxes at scale R .

9.5 A quasi-isometry quasi-respects the height

In this section we fix two points at the same height, at an arbitrary distance, and we estimate the difference of height between their respective images under Φ .

Theorem 9.5.1. *For $0 < \theta \leq_{k,c,\mathfrak{M}} 1$, there exists $M(k, c, \mathfrak{M}, \theta)$ (here M depends also on θ) such that for all p and q in $X \rtimes Y$ with $h(p) = h(q)$ we have*

$$\Delta h(\Phi(p), \Phi(q)) \leq \theta d(p, q) + M \quad (9.32)$$

To do so we construct two sequences of growing boxes, until they cover the two given points, then we apply successively Theorem 9.4.1 on each of these boxes. The next lemmas ensure us that estimates made on a box spread to the following box in the growing sequence.

Definition 9.5.2. (Rectangle) *Let $0 < \theta \leq_{k,c,\mathfrak{M}} 1$ be as in Theorem 9.4.1, $z \in \mathbb{R}$ and $P := (X \rtimes Y)_z$ a level-set of the height function. The rectangle $R(L) \subset P$ is the intersection of P with a box $\mathcal{B}(2L)$ which has $h^+(\mathcal{B}) = z + L$. Let $R^+(L)$ denote the thickening of $R(L)$ along the height by the amount $\theta^{\frac{1}{8}} L$. More precisely we have $R^+(L) := \mathcal{B}(2L) \cap h^{-1}\left(\left[z - \theta^{\frac{1}{8}} L, z + \theta^{\frac{1}{8}} L\right]\right)$.*

Lemma 9.5.3. For $0 < \theta \leq_{k,c,\varkappa} 1$, $L \geq_{k,c,\varkappa} \frac{M}{\theta}$ and every rectangle $R(L) \subset P$ there exist $U \subset R^+(L)$ and a product map $\hat{\Phi} : U \rightarrow X \times Y$ such that:

1. $\lambda(U) \geq \left(1 - M\theta^{\frac{1}{8}}\right) \lambda(R^+(L))$
2. $d(\Phi|_U, \hat{\Phi}) \leq_{k,c,\varkappa} \theta^{\frac{1}{8}} L$
3. Almost all vertical geodesic segments have $M\theta^{\frac{1}{8}}$ -monotone image under Φ .

Proof. Let U' be the U of Theorem 9.4.1 and let us define the set U of this lemma 9.5.3 as

$$U := U' \cap h^{-1} \left(\left[z - \theta^{\frac{1}{8}} L, z + \theta^{\frac{1}{8}} L \right] \right)$$

Then first point holds

$$\begin{aligned} \lambda(U^c) &\leq \lambda((U')^c) \leq M\theta^{\frac{2}{8}} \lambda(\mathcal{B}), \quad \text{by Theorem 9.4.1 applied on } \mathcal{B}(2L), \\ &\leq_{k,c,\varkappa} \theta^{\frac{2}{8}} \int_{[z-L, z+L]} \lambda_0(\mathcal{B}_0) dt, \quad \text{by Property 8.1.5,} \\ &\leq_{k,c,\varkappa} \theta^{\frac{2}{8}} \left(\theta^{-\frac{1}{8}} \theta^{\frac{1}{8}} \right) 2L \lambda_0(\mathcal{B}_0) \leq_{k,c,\varkappa} \theta^{\frac{1}{8}} \lambda(R^+(L)), \quad \text{by Property 8.1.5.} \end{aligned}$$

The second point also holds by Theorem 9.4.1, and since $\theta^{\frac{1}{8}} \geq \sqrt{\theta}$. The third and last point holds by Lemma 9.4.4. \square

Now we tile P successively with rectangles of exponentially growing size, from the constant $L_0 := \frac{M}{\theta}$ of Theorem 9.4.1 until one of these widened rectangles contains the two previously given points p and q . Let $L_j = (1 + \theta^{\frac{1}{16}})^j L_0$ for all $j \in \mathbb{N}^*$. For all $j > 0$ we tile P with a family of rectangles $(R_{j,k})_{k \in \mathbb{N}}$ at scale L_j . For all $p \in X \times Y$ let us denote by $B_j[p]$ the unique box of the j 'th tiling containing p , and let $R_j[p]$ be the rectangle of the j 'th tiling contained in $B_j[p]$. For all rectangles $R_{j,k}$, Lemma 9.5.3 provides us with a subset $U_{j,k} \subset R_{j,k}^+$. Let us denote by

$$U_j = \bigcup_{k=1}^{+\infty} U_{j,k}.$$

Hence for any $p \in U_j$ and $q \in R_j^+[p] \cap U_j$

$$\Delta h(\Phi(p), \Phi(q)) \leq 2\theta^{\frac{1}{8}} L_j$$

Thanks to the following Lemma, we can control the difference of height of the image by Φ of two points taken in consecutive rectangles.

Lemma 9.5.4. For any $p \in U_j$ and $q \in R_{j+1}^+[p] \cap U_j$

$$\Delta h(\Phi(p), \Phi(q)) \leq_{k,c,\varkappa} \theta^{\frac{1}{8}} L_j$$

Proof. Let $a := (p^X, q^Y)$, since $M\theta^{\frac{1}{8}} < 1$, there exists an X -horosphere H which intersects both $R_j^+[p] \cap U_j$ and $R_{j+1}^+[a] \cap U_j$, let us denote these intersections by p_1 and a_1 respectively. By construction we have

$$\Delta h(p, p_1) \leq \theta^{\frac{1}{8}} L_j \tag{9.33}$$

$$\Delta h(a, a_1) \leq \theta^{\frac{1}{8}} L_j \tag{9.34}$$

The points p_1 and a_1 are in the same box at scale L_{j+1} , and surrounded by "good" vertical geodesic since they are in U_j . Therefore we can construct a coarse quadrilateral containing p_1 and a_1 . To do so, for

$i = 1, 2$, let $\gamma_1^Y, \gamma_2^Y \subset Y$ be two vertical geodesic segments leaving $D_{M_0}(p_1^Y) = D_{M_0}(a_1^Y)$, let $\gamma'^X \subset Y$ be a geodesic segment leaving near $D_{M_0}(p_1^X)$ and $\gamma^X \subset X$ be a vertical geodesic segment leaving $D_{M_0}(a_1^X)$, where M_0 is the constant of assumption (E2). Then consider the four vertical geodesic segments of $X \bowtie Y$

$$\begin{aligned}\gamma_i &:= (\gamma^X, \gamma_i^Y) \\ \gamma'_i &:= (\gamma'^X, \gamma_i^Y).\end{aligned}$$

Most of such vertical geodesic segments have $M\theta^{\frac{1}{8}}$ -monotone image under Φ (Lemma 8.7.3 used thanks to the third point of Corollary 9.5.3) and are diverging from each other (Lemma 8.8.1), hence without loss of generality, γ_i and γ'_i can be chosen that way. We parametrise them by arclength starting at the height of p_1 and a_1 . Furthermore, p_1 and a_1 are in the same box at scale L_{j+1} with $p_1^Y = a_1^Y$, hence we have

$$\begin{aligned}d_{\bowtie}(p_1, a_1) &\leq d_X(p_1^X, a_1^X) - M(\bowtie), \quad \text{by Corollary 4.3.4} \\ &\leq 2L_{j+1} - M + 2M_0, \quad \text{by the definition of a box at scale } L_{j+1}.\end{aligned}$$

Therefore, by Lemma 3.1.2 applied with $x_1 = p_1^X$ and $x_2 = a_1^X$ we have

$$d_X(\gamma_i^X(L_{j+1}), (\gamma'_i)^X(L_{j+1})) \leq_{\bowtie} 1$$

Furthermore $d_Y(\gamma_i^Y(L_{j+1}), (\gamma'_i)^Y(L_{j+1})) = 0$, hence $d_{\bowtie}(\gamma_i(L_{j+1}), \gamma'_i(L_{j+1})) \leq_{\bowtie} 1$. Consequently, applying Proposition 7.3.2 with $D = M\theta^{\frac{1}{8}}R$ on the coarse vertical quadrilateral $\Phi(\gamma_1 \cup \gamma'_1 \cup \gamma_2 \cup \gamma'_2)$ gives

$$\Delta h(\Phi(p_1), \Phi(a_1)) \leq_{k,c,\bowtie} \theta^{\frac{1}{8}} L_j.$$

Similarly we can find $a_2 \in R_j^+[a] \cap U_j$ and $q_2 \in R_j^+[q] \cap U_j$ on the same Y -horosphere such that $\Delta h(\Phi(q_2), \Phi(a_2)) \leq_{k,c,\bowtie} \theta^{\frac{1}{8}} L_j$. Which, in combination with inequalities (9.33) and (9.34), ends the proof. \square

Then we prove that the estimate is still true when taking the second point in the associate subspace U_{j+1} of the wider rectangle.

Lemma 9.5.5. *For any $a \in R_j^+[p] \cap U_j$ and $b \in R_{j+1}^+[p] \cap U_{j+1}$*

$$\Delta h(\Phi(a), \Phi(b)) \leq_{k,c,\bowtie} \theta^{\frac{1}{8}} L_j$$

Proof. Since the projections of U_j and U_{j+1} on P cover almost all $R_{j+1}[p]$, we can find $a' \in U_j \cap R_{j+1}^+[p]$ and $b' \in U_{j+1} \cap R_{j+1}^+[p]$ on the same vertical geodesic, which implies $d_{\bowtie}(a', b') \leq 2\theta^{\frac{1}{8}} L_{j+1}$. Furthermore Lemma 9.5.4 applied on a and a' gives

$$\Delta h(\Phi(a), \Phi(a')) \leq_{k,c,\bowtie} \theta^{\frac{1}{8}} L_j$$

Similarly we have $\Delta h(\Phi(b'), \Phi(b)) \leq_{k,c,\bowtie} \theta^{\frac{1}{8}} L_{j+1}$. Therefore by the triangle inequality:

$$\begin{aligned}\Delta h(\Phi(a), \Phi(b)) &\leq \Delta h(\Phi(a), \Phi(a')) + \Delta h(\Phi(a'), \Phi(b')) + \Delta h(\Phi(b'), \Phi(b)) \\ &\leq_{k,c,\bowtie} \theta^{\frac{1}{8}} L_j + \theta^{\frac{1}{8}} L_{j+1} \leq \theta^{\frac{1}{8}} L_j, \quad \text{since } (1 + \theta^{\frac{1}{16}}) L_j \leq 2L_j\end{aligned}$$

\square

We now construct the sequence of growing rectangles, and prove Theorem 9.5.1

Proof of Theorem 9.5.1 We have both:

$$\begin{aligned} R_0[p] &\subset R_1[p] \subset R_2[p] \subset \dots \\ R_0[q] &\subset R_1[q] \subset R_2[q] \subset \dots \end{aligned}$$

Let $N \in \mathbb{N}$ be such that $L_{N-1} \leq d_{\mathfrak{M}}(p, q) \leq L_N$. The N 'th tiling can be chosen such that $R_N[p] = R_N[q]$. Now for $0 \leq j \leq N$, pick $p_j \in R_j[p] \cap U_j$ and $q_j \in R_j[q] \cap U_j$. We may assume that $p_N = q_N$. Hence computing the difference of height between $\Phi(p_0)$ and $\Phi(q_0)$ we have

$$\begin{aligned} \Delta h(\Phi(p_0), \Phi(q_0)) &\leq \sum_{j=0}^{N-1} \Delta h(\Phi(p_j), \Phi(p_{j+1})) + \sum_{j=0}^{N-1} \Delta h(\Phi(q_{j+1}), \Phi(q_j)), \quad \text{since } p_N = q_N, \\ &\leq_{\mathfrak{M}} \sum_{j=0}^{N-1} \theta^{\frac{1}{8}} L_{j+1} = \sum_{j=0}^{N-1} \theta^{\frac{1}{8}} \left(1 + \theta^{\frac{1}{16}}\right)^j L_0, \quad \text{by Lemma 9.5.5,} \\ &= \frac{\theta^{\frac{1}{8}}}{\theta^{\frac{1}{16}}} L_N \leq_{\mathfrak{M}} \theta^{\frac{1}{16}} d_{\mathfrak{M}}(p, q), \quad \text{since } L_N \asymp_{\mathfrak{M}} d_{\mathfrak{M}}(p, q). \end{aligned}$$

Moreover, $p_0 \in R_0[p]$ and $q_0 \in R_0[q]$, hence

$$\Delta h(\Phi(p), \Phi(p_0)) \leq d_{\mathfrak{M}}(\Phi(p), \Phi(p_0)) \leq kL_0 + c \leq 2kL_0$$

And similarly $\Delta h(\Phi(q), \Phi(q_0)) \leq 2kL_0$. Therefore by the triangle inequality

$$\begin{aligned} \Delta h(\Phi(p), \Phi(q)) &\leq \Delta h(\Phi(p), \Phi(p_0)) + \Delta h(\Phi(p_0), \Phi(q_0)) + \Delta h(\Phi(q_0), \Phi(q)) \\ &\leq_{k,c,\mathfrak{M}} \theta^{\frac{1}{16}} d_{\mathfrak{M}}(p, q) + L_0. \end{aligned}$$

□

Corollary 9.5.6. *Any vertical geodesic ray V of $X \rtimes Y$ satisfies, for all $t_1, t_2 \in \mathbb{R}$*

$$h(\Phi \circ V(t_1)) = h(\Phi \circ V(t_2)) \quad \Rightarrow \quad |t_1 - t_2| \leq_{k,c,\mathfrak{M}} 1$$

Proof. Suppose V is a vertical geodesic segment parametrised by arclength. Suppose $0 < t_1 < t_2$ are such that $h(\Phi(V(t_1))) = h(\Phi(V(t_2)))$. We apply Theorem 9.5.1 on Φ^{-1} with $p = \Phi(V(t_1))$, $q = \Phi(V(t_2))$, where θ is here fixed and depends only on k, c and the metric measured space $(X \rtimes Y, d_{\mathfrak{M}})$. Then we have

$$\Delta h(V(t_1), V(t_2)) \leq_{k,c,\mathfrak{M}} \theta^{\frac{1}{16}} |t_1 - t_2| + M(\theta) = \theta |t_1 - t_2| + M(k, c, \mathfrak{M}) \quad (9.35)$$

However $\Delta h(V(t_1), V(t_2)) = |t_1 - t_2|$, hence

$$\left(1 - \theta^{\frac{1}{16}}\right) |t_1 - t_2| \leq_{k,c,\mathfrak{M}} M(k, c, \mathfrak{M}) \leq_{k,c,\mathfrak{M}} 1$$

Hence $|t_1 - t_2| \leq_{k,c,\mathfrak{M}} 1$ since $\theta^{\frac{1}{16}} \leq \frac{1}{2}$. □

This is stronger than being ε -monotone since it true on all \mathbb{R} .

9.6 Factorisation of a quasi-isometry on the whole space

Finally, we provide the proof of the Theorem 9.0.1, which states that Φ is close to a product map $\hat{\Phi}$ on the whole space $X \rtimes Y$.

Proof of Theorem 9.0.1 We first pick an arbitrary vertical geodesic V_0^X of X and an arbitrary vertical geodesic V_0^Y of Y . Then we work with the two embedded copies $X_0 := X \rtimes V_0^Y$ and $Y_0 := V_0^X \rtimes Y$ of X and Y in $X \rtimes Y$. Let $p \in X \rtimes Y$, there exist a unique $a \in X_0$ and a unique $b \in Y_0$ such that $p^X = a^X$ and $p^Y = b^Y$. We can construct a coarse vertical quadrilateral Q containing p and a as in Lemma 9.2.2. Thanks to Corollary 9.5.6, we know that $\Phi(Q)$ is in the $M(k, c, \rtimes)$ -neighbourhood of a coarse vertical tetrahedron Q' on which we use Proposition 7.3.2. This gives us

$$d_X(\Phi(p)^X, \Phi(a)^X) \leq_{k,c,\rtimes} 1 \quad (9.36)$$

$$\Delta h(\Phi(p)^X, \Phi(a)^X) \leq_{k,c,\rtimes} 1 \quad (9.37)$$

Similarly we have $d_Y(\Phi(p)^Y, \Phi(b)^Y) \leq_{k,c,\rtimes} 1$. Let us denote

$$\begin{aligned} \hat{\Phi}^X : X &\rightarrow X \\ x &\mapsto \Phi(x, V_0^Y(-h(x)))^X \end{aligned}$$

By rewriting inequality 9.36 we have

$$\begin{aligned} d_X(\Phi(p)^X, \hat{\Phi}^X(p^X)) &= d_X(\Phi(p)^X, \hat{\Phi}^X(a^X)) = d_X(\Phi(p)^X, \Phi(a^X, V_0^Y(-h(a^X)))^X) \\ &= d_X(\Phi(p)^X, \Phi(a)^X) \leq_{k,c,\rtimes} 1 \end{aligned}$$

Similarly by denoting $\hat{\Phi}^Y := \Phi(V_0^X(-h(y)), y)^Y$ for all $y \in Y$, we have

$$d_Y(\Phi(p)^Y, \hat{\Phi}^Y(p^Y)) \leq_{k,c,\rtimes} 1 \quad (9.38)$$

The last problem is that given a point p , the heights of $\hat{\Phi}^X(p^X)$ and $\hat{\Phi}^Y(p^Y)$ may differ. As in the proof of Theorem 9.2.1, inequality 9.37 guaranties that they are sufficiently close, which allows us to chose $\hat{\Phi}^X$ and $\hat{\Phi}^Y$ such that for $\hat{\Phi} := (\hat{\Phi}^X, \hat{\Phi}^Y)$ we have

$$d_{\rtimes}(\Phi(p), \hat{\Phi}(p)) \leq_{k,c,\rtimes} 1$$

$$\Delta h(\Phi(p), \hat{\Phi}(p)) \leq_{k,c,\rtimes} 1$$

We now prove that $\hat{\Phi}^X$ and $\hat{\Phi}^Y$ are quasi-isometries. Let $x, x' \in X$, then

$$\begin{aligned} d_X(\hat{\Phi}^X(x), \hat{\Phi}^X(x')) &\leq_{k,c,\rtimes} d_X(\Phi(x, V_0^Y(-h(x)))^X, \Phi(x', V_0^Y(-h(x')))^X) \\ &\leq d_{\rtimes}(\Phi(x, V_0^Y(-h(x))), \Phi(x', V_0^Y(-h(x')))) \\ &\leq kd_{\rtimes}((x, V_0^Y(-h(x))), (x', V_0^Y(-h(x')))) + c \\ &\leq kd_X(x, x') + d_Y(V_0^Y(-h(x)), V_0^Y(-h(x')))) + c + M(k, c, \rtimes), \quad \text{by Corollary 4.3.4} \\ &\leq kd_X(x, x') + \Delta h(x, x') + c + M \leq (k+1)d_X(x, x') + c + M. \end{aligned}$$

Similarly

$$\begin{aligned} d_X(\hat{\Phi}^X(x), \hat{\Phi}^X(x')) &\geq_{k,c,\rtimes} d_X(\Phi(x, V_0^Y(-h(x)))^X, \Phi(x', V_0^Y(-h(x')))^X) \\ &\geq 2d_{\rtimes}(\Phi(x, V_0^Y(-h(x))), \Phi(x', V_0^Y(-h(x')))) - d_Y(\Phi(x, V_0^Y(-h(x)))^Y, \Phi(x', V_0^Y(-h(x')))^Y) \\ &\geq \frac{1}{k}d_X(x, x') - c - d_Y(\hat{\Phi}^Y(V_0^Y(-h(x))), \hat{\Phi}^Y(V_0^Y(-h(x')))) - 2M, \quad \text{by the triangle inequality,} \\ &\geq \frac{1}{k}d_X(x, x') - c - 2M. \end{aligned}$$

The proof that $\hat{\Phi}^Y$ is a quasi-isometry is similar. □

Chapter 10

Some solvable Lie groups as horospherical products

In this chapter, we provide a characterisation of the quasi-isometry group of the horospherical product of two Heintze groups. See Theorem [10.3.4](#) for the precise description.

10.1 Admissibility of Heintze groups

In this section we show that a Heintze group satisfies the conditions required to apply our main rigidity result [9.0.1](#).

Definition 10.1.1. (*Heintze group*)

A Heintze group is a solvable Lie group $S = N \rtimes_A \mathbb{R}$ where N is a connected, simply connected, nilpotent Lie group, and A is a derivation of $\text{Lie}(N)$ whose eigenvalues all have positive real parts.

Heintze obtained in his work [\[20\]](#) that any negatively curved homogeneous manifold is isometric to a Heintze group.

Remark 10.1.2. A Heintze group equipped with a left-invariant metric has a strictly negative sectional curvature, see [\[20\]](#) for further details. From now on we fix g a left-invariant metric on $N \rtimes_A \mathbb{R}$ with maximal sectional curvature -1 . Since $N \rtimes_A \mathbb{R}$ is simply connected, it is a $CAT(-1)$ -space.

From now on we fix the metric g such that $S = N \rtimes_A \mathbb{R}$ is a $CAT(-1)$ space. Therefore S is a δ -hyperbolic, Busemann, proper, geodesically complete metric space. Moreover, we show that S satisfies all three assumptions of Definition [8.1.1](#). The assumption (E1) holds thanks to the decomposition $S = N \rtimes_A \mathbb{R}$. We have for all $(n, z) \in N \rtimes_A \mathbb{R}$, $g_{(n,z)} = \exp(-zA)(g_N)_n \exp(-zA)^t \oplus dz^2$, where g_N is the restriction of g to the nilpotent Lie group N . Let us denote by $g_z := \exp(-zA)g_N \exp(-zA)^t$ a left invariant metric on N , then let us denote by $\mu := \mu_g$ the measure on S induced by g and by $\mu_z := \mu_{g_z}$ the measure on N induced by g_z . Then for all measurable subset $U \subset S$ we have

$$\begin{aligned} \mu(U) &:= \int_S \mathbb{1}_U(n, z) d\mu_g(n, z) = \int_{\mathbb{R}} \int_N \mathbb{1}_U(n, z) d\mu_{g_z}(n) dz \\ &= \int_{\mathbb{R}} \mu_z(U_z) dz, \end{aligned}$$

where $U_z := \{n \in N \mid (n, z) \in U\}$. Assumption (E2) holds with constant $M_0 = 1$ since $g_{n,z}$ is left-invariant, and assumption (E3) arises from the fact that $\det(g_z) = \exp(-2z \text{tr}(A)) \det(g)$. Therefore, any Heintze group is an admissible horo-pointed space.

Let us denote $S_1 := N_1 \rtimes_{A_1} \mathbb{R}$ and $S_2 := N_2 \rtimes_{A_2} \mathbb{R}$, then

$$S_1 \rtimes S_2 = (N_1 \times N_2) \rtimes_A \mathbb{R},$$

with A the matrix $\text{diag}(A_1, -A_2)$.

10.2 Precision on the components of the product map

We first refine Theorem 9.0.1 for Heintze groups.

Remark 10.2.1. For any vertical geodesics V of $(N_1 \times N_2) \rtimes_A \mathbb{R}$ there exist $n_1 \in N_1, n_2 \in N_2$ and an arclength parametrisation of V such that $V(t) = (n_1, n_2, t)$.

Let $\Phi \in \text{QI}((N_1 \times N_2) \rtimes_A \mathbb{R})$ be a (k, c) -quasi-isometry. By Theorem 9.0.1 there exist $\hat{\Phi}_1 : S_1 \rightarrow S_1$ and $\hat{\Phi}_2 : S_2 \rightarrow S_2$ such that

$$d_{\mathfrak{M}}(\Phi, (\hat{\Phi}_1, \hat{\Phi}_2)) \leq_{k,c,\mathfrak{M}} 1.$$

Lemma 10.2.2. Let $i \in \{1, 2\}$, then for any vertical geodesic $V \in S_i$, there exists a vertical geodesic V' such that

$$d_{\text{Hff}}(\hat{\Phi}_i(V), V') \leq_{k,c,\mathfrak{M}} 1$$

Proof. Since $S_i = N_i \rtimes_{A_i} \mathbb{R}$ is a Gromov hyperbolic space, there exists $M(k, c, \mathfrak{M})$ such that image of a vertical geodesic by $\hat{\Phi}_i$ is in a M -neighbourhood of a geodesic γ of S_i . By Corollary 9.5.6 γ is a vertical geodesic, hence for $V' := \gamma$ we have $d_{\text{Hff}}(\hat{\Phi}_i(V), V') \leq_{k,c,\mathfrak{M}} 1$. \square

Let $n \in N_i$ and let us denote by V_n the vertical geodesic $V_n : \mathbb{R} \rightarrow S_i ; t \mapsto (n, t)$. By Lemma 10.2.2 there exists a vertical geodesic V'_n such that

$$d_{\text{Hff}}(\hat{\Phi}_i(V_n), V'_n) \leq_{k,c,\mathfrak{M}} 1 \quad (10.1)$$

Furthermore V'_n is unique since it is an infinite geodesic of the Heintze group S_i . We define a map $\Psi_i : N_i \rightarrow N_i$ as the following

$$\text{For all } n \in N, \Psi_i(n) = P(V'_n(0)), \quad (10.2)$$

where $P : N_i \rtimes_{A_i} \mathbb{R} \rightarrow N_i$ is the natural projection on N_i .

The goal of this subsections is to prove the following theorem.

Theorem 10.2.3. There exists $t_0 \in \mathbb{R}$ such that for the aforementioned Ψ_i we have

$$d_{\mathfrak{M}}(\Phi, (\Psi_1, \Psi_2, id_{\mathbb{R}} + t_0)) \leq_{k,c,\mathfrak{M}} 1.$$

We first show $\hat{\Phi}_i$ and Ψ_i are related.

Lemma 10.2.4. Let $i \in \{1, 2\}$. There exists $f_i : \mathbb{R} \rightarrow \mathbb{R}$ such that for all $(n, t) \in S_i$

$$d_{S_i}(\hat{\Phi}_i(n, t), (\Psi_i(n), f_i(t))) \leq_{k,c,\mathfrak{M}} 1$$

Proof. Let $f_i : \mathbb{R} \rightarrow \mathbb{R}; t \mapsto h(\hat{\Phi}_i(e_{N_i}, t))$. Then by Theorem 9.0.1 we have that $h(\hat{\Phi}_i(n, t)) = f_i(t)$ for all $n \in N_i$. Therefore by the definition of Ψ_i we have $(\Psi_i(n), f_i(t)) = V'_n(f_i(t))$. Hence

$$d_{S_i}(\hat{\Phi}_i(n, t), (\Psi_i(n), f_i(t))) = d_{S_i}(\hat{\Phi}_i(n, t), V'_n(f_i(t))). \quad (10.3)$$

However by inequality (10.1), there exists $s_t \in \mathbb{R}$ such that

$$d_{S_i}(\hat{\Phi}_i(n, t), V'_n(s_t)) \leq_{k,c,\delta} 1 \quad (10.4)$$

Furthermore we know that

$$1 \geq_{k,c,\mathfrak{M}} d_{S_i}(\hat{\Phi}_i(n, t), V'_n(s_t)) \geq \Delta h(\hat{\Phi}_i(n, t), V'_n(s_t)) = |f_i(t) - s_t| \quad (10.5)$$

Therefore

$$\begin{aligned} d_{S_i}(\hat{\Phi}_i(n, t), V'_n(f_i(t))) &\leq d_{S_i}(\hat{\Phi}_i(n, t), V'_n(s_t)) + d_{S_i}(V'_n(s_t), V'_n(f_i(t))) \quad , \text{ by the triangle inequality,} \\ &= d_{S_i}(\hat{\Phi}_i(n, t), V'_n(s_t)) + |f_i(t) - s_t| \leq_{k,c,\mathfrak{M}} 1 \quad , \text{ by inequalities (10.4) and (10.5).} \end{aligned}$$

Combined with equality (10.3) it provides us with $d_{S_i}(\hat{\Phi}_i(n, t), (\Psi_i(n), f_i(t))) \leq_{k,c,\mathfrak{M}} 1$ \square

Corollary 10.2.5. (Quasi-isometries quasi-preserve the horosphere volume)

Let $t \in \mathbb{R}$, $r > 0$ and $n \in N_i$. Then the map $\tilde{\Phi}_i := (\Psi_i, f_i)$ quasi-preserves the volume of any disk $D := D_r(n, t)$

$$\mu_t^{S_i}(D) \simeq_{k,c,\varkappa} \mu_t^{S_i}(\mathcal{N}_1(\tilde{\Phi}_i(D)))$$

Proof. By Lemma 10.2.4 there exists $M(k, c, \varkappa)$ such that $\tilde{\Phi}_i$ is M -close to $\hat{\Phi}_i$. Therefore, there exists k', c' depending only on k, c and $S_1 \varkappa S_2$ such that $\tilde{\Phi}_i$ is a (k', c') -quasi-isometry.

We first exhibit Z a $2(k'c' + 1)$ -maximal separating set of D . Then $\tilde{\Phi}_i(Z)$ verifies:

1. The disks $D_1(p)$ with $p \in \tilde{\Phi}_i(Z)$ are pairwise disjoint.
2. $\bigcup_{p \in \tilde{\Phi}_i(Z)} D_1(p) \subset \mathcal{N}_1(\tilde{\Phi}_i(D)) \subset \bigcup_{p \in \tilde{\Phi}_i(Z)} D_{2k'(k'c'+1)+c'+1}(p)$

Furthermore by Lemma 8.1.2, we have $\forall (n, t) \in Z$

$$\begin{aligned} \mu_t^{S_i}(D_{k'c'}(n, t)) &\simeq_{k,c,\varkappa} \mu_t^{S_i}(D_{2k'c'}(n, t)) \\ \mu_{f_i(t)}^{S_i}(D_1(\tilde{\Phi}_i(n, t))) &\simeq_{k,c,\varkappa} \mu_{f_i(t)}^{S_i}(D_{2k'(k'c'+1)+c'+1}(\tilde{\Phi}_i(n, t))) \end{aligned}$$

Therefore

$$\mu_t^{S_i}(D) \simeq_{k,c,\varkappa} \#Z \simeq_{k,c,\varkappa} \mu_t^{S_i}(\mathcal{N}_1(\tilde{\Phi}_i(D)))$$

□

Lemma 10.2.6. (Quasi-isometries quasi-translate the height)

Let $f_i : \mathbb{R} \rightarrow \mathbb{R}$ be the function involved in Lemma 10.2.4. Then for all $t \in \mathbb{R}$

$$|t - (f_i(t) - f_i(0))| \leq_{k,c,\varkappa} 1$$

Proof. We recall that for all $t \in \mathbb{R}$, $f_i(t) := h(\hat{\Phi}_i(e_{N_i}, t))$. Let $n \in N_i$, $r > 0$, $t \in \mathbb{R}$, and let us denote $U \subset N_i$ such that $D_r(n, 0) = (U, 0)$. Then we have

$$\mu_0^{S_i}(U, 0) = e^{2\text{tr}(A_i)t} \mu_t^{S_i}(U, t) \quad (10.6)$$

However $\tilde{\Phi}_i(U, 0) = (\Psi_i(U), f_i(0))$ and $\tilde{\Phi}_i(U, t) = (\Psi_i(U), f_i(t))$, therefore

$$\begin{aligned} \mu_{f_i(0)}^{S_i}(\mathcal{N}_1(\tilde{\Phi}_i(U, 0))) &= \mu_{f_i(0)}^{S_i}(\mathcal{N}_1(\Psi_i(U), f_i(0))) \\ &= e^{2\text{tr}(A_i)(f_i(t)-f_i(0))} \mu_{f_i(t)}^{S_i}(\mathcal{N}_1(\Psi_i(U), f_i(t))) \\ &= e^{2\text{tr}(A_i)(f_i(t)-f_i(0))} \mu_{f_i(t)}^{S_i}(\mathcal{N}_1(\tilde{\Phi}_i(U, t))) \end{aligned} \quad (10.7)$$

Furthermore by Lemma 10.2.5 we have

$$\begin{aligned} \mu_0^{S_i}(U, 0) &\simeq_{k,c,\varkappa} \mu_{f_i(0)}^{S_i}(\mathcal{N}_1(\tilde{\Phi}_i(U, 0))) \\ \mu_t^{S_i}(U, t) &\simeq_{k,c,\varkappa} \mu_{f_i(t)}^{S_i}(\mathcal{N}_1(\tilde{\Phi}_i(U, t))) \end{aligned}$$

In combination with equalities (10.6) and (10.7), it provides us with

$$\begin{aligned} \mu_0^{S_i}(U, 0) &= e^{2\text{tr}(A_i)t} \mu_t^{S_i}(U, t) \simeq_{k,c,\varkappa} e^{2\text{tr}(A_i)t} \mu_{f_i(t)}^{S_i}(\mathcal{N}_1(\tilde{\Phi}_i(U, t))) \\ &= e^{2\text{tr}(A_i)t} e^{2\text{tr}(A_i)(f_i(0)-f_i(t))} \mu_{f_i(0)}^{S_i}(\mathcal{N}_1(\tilde{\Phi}_i(U, 0))) \\ &\simeq_{k,c,\varkappa} e^{2\text{tr}(A_i)t} e^{2\text{tr}(A_i)(f_i(0)-f_i(t))} \mu_0^{S_i}(U, 0) \end{aligned}$$

Hence we have $e^{2\text{tr}(A_i)t} \simeq_{k,c,\varkappa} e^{2\text{tr}(A_i)(f_i(t)-f_i(0))}$, which, composed with the logarithm, gives us

$$|t - (f_i(t) - f_i(0))| \leq_{k,c,\varkappa} 1. \quad (10.8)$$

□

Corollary 10.2.7. *There exists $t_0 \in \mathbb{R}$ such that for $i \in \{1, 2\}$ and for all $(n, t) \in N_i \times \mathbb{R}$*

$$d_{S_i}(\hat{\Phi}_i(n, t), (\Psi_i(n), t + t_0)) \leq_{k, c, \varkappa} 1$$

Proof. The proof is a direct application of Lemmas 10.2.4 and 10.2.6 by taking $t_0 := f_i(0)$. \square

In this corollary t_0 depends on Φ .

Proof of Theorem 10.2.3. Using Lemma 10.2.7 on N_1 and N_2 provides us with Theorem 10.2.3. \square

10.3 Hamenstädt distance and Product map of Bi-Lipschitz functions.

As presented in section 5.3 of [6], the parabolic visual boundary of $N_i \times \mathbb{R}$ may be identified with the Lie group N_i endowed with this A_i -homogeneous Hamenstädt distance.

Definition 10.3.1. (*Hamenstädt distance*) *For any $n, m \in N_i$, we define their Hamenstädt distance as*

$$d_H(n, m) := \exp\left(-\frac{1}{2} \lim_{s \rightarrow +\infty} (2s - d_{S_i}((n, -s), (m, -s)))\right)$$

We denote $\text{Bilip}(N)$ the group of Bi-Lipschitz functions of N for the Hamenstädt distance.

$$\text{Bilip}(N_i) := \{\Psi : (N_i, d_H) \rightarrow (N_i, d_H) \mid \exists k \geq 1, \Psi \text{ is a } (k, 0)\text{-quasi-isometry}\}.$$

Two quasi-isometries Φ and Φ' are said to be equivalent when they are at finite distance from each other.

$$\Phi \sim \Phi' \iff \sup_x d_{\varkappa}(\Phi(x), \Phi'(x)) < +\infty$$

In this section we prove the following characterisation of the quasi-isometry group of $S_1 \times S_2 = (N_1 \times N_2) \times_A \mathbb{R}$.

Theorem 10.3.2. *Let $N_1 \times_{A_1} \mathbb{R}$ and $N_2 \times_{A_2} \mathbb{R}$ be two Heintze group, let $\Phi \in \text{QI}((N_1 \times N_2) \times_A \mathbb{R})$ and let Ψ_1, Ψ_2 be as in Theorem 10.2.3, we have the following isomorphisme.*

$$\begin{aligned} f : \text{QI}((N_1 \times N_2) \times_A \mathbb{R}) / \sim &\rightarrow \text{Bilip}(N_1) \times \text{Bilip}(N_2) \\ \Phi &\mapsto (\Psi_1, \Psi_2) \end{aligned}$$

This distance is related to the height divergence of vertical geodesic in the following way.

Lemma 10.3.3. (*Extended Backward Lemma*) *Let $n, m \in N_i$, let $V : t \mapsto (n, t)$ and let $W : t \mapsto (m, t)$, then*

$$d_H(n, m) \asymp_{k, c, \varkappa} \exp(h_{\text{Div}}(V, W))$$

See Corollary 6.0.3 for the definition of $h_{\text{Div}}(V, W)$.

Proof. By the Corollary 6.0.3 there exists a height $h_{\text{Div}}(V, W) \in \mathbb{R}$ such that V and W diverge from each other at the height $h_{\text{Div}}(V, W)$. Hence there exists $M(k, c, \varkappa)$ such that for all $s_1 \leq s_2 \leq h_{\text{Div}}(V, W)$

$$d(V(s_2), W(s_2)) - M \leq d_{S_i}(V(s_1), W(s_1)) + 2|s_2 - s_1| \leq d_{S_i}(V(s_2), W(s_2)) + M.$$

Therefore

$$\exp(d_{S_i}(V(s_1), W(s_1)) + 2|s_2 - s_1|) \asymp_{k, c, \varkappa} \exp(d_{S_i}(V(s_2), W(s_2))), \quad (10.9)$$

Let us denote $h_0 := h_{\text{Div}}(V, W)$. Then we can compute de Hamenstädt distance $d_H(n, m)$

$$\begin{aligned}
d_H(n, m) &= \exp\left(-\frac{1}{2} \lim_{s \rightarrow +\infty} \left(2s - d_{S_i}(V(-s)W(-s))\right)\right) \\
&\asymp_{k,c,\varkappa} \exp\left(-\frac{1}{2} \lim_{s \rightarrow +\infty} \left(2s - d_{S_i}(V(h_0), W(h_0)) - (2h_0 + 2s)\right)\right) \quad , \text{ by inequality (10.9),} \\
&\asymp_{k,c,\varkappa} \exp\left(-\frac{1}{2} \lim_{s \rightarrow +\infty} \left(-d_{S_i}(V(h_0), W(h_0)) - 2h_0\right)\right) \\
&= \exp\left(\frac{d_{S_i}(V(h_0), W(h_0))}{2} + h_0\right) = \exp\left(\frac{d_{S_i}(V(h_0), W(h_0))}{2}\right) \exp(h_0) \\
&\asymp_{k,c,\varkappa} \exp(h_0) \quad , \text{ by definition of } h_{\text{Div}}(V, W).
\end{aligned}$$

□

We show that the aforementioned maps Ψ_i are bi-Lipschitz.

Theorem 10.3.4. *Let Ψ_i be the map of Theorem 10.2.3. Then Ψ_i is a bi-Lipschitz map on (N_i, d_H) , with d_H the Hamenstädt distance.*

Proof. Let $n, m \in N_i$ and let $V : t \mapsto (n, t)$ and $W : t \mapsto (m, t)$ be two vertical geodesics of $N_i \times_{A_i} \mathbb{R}$. Then by the Lemma 10.3.3 we have

$$d_H(n, m) \asymp_{k,c,\varkappa} \exp(h_{\text{Div}}(V, W))$$

Since $\Phi_i := (\Psi_i, \text{id}_{\mathbb{R}} + t_0)$ is a (k', c') -quasi-isometry, we have:

1. $d_{S_i}((\Psi_i(n), h_{\text{Div}}(V, W) + t_0), (\Psi_i(m), h_{\text{Div}}(V, W) + t_0)) \asymp_{k,c,\varkappa} 1$
2. $\forall s \geq h_{\text{Div}}(V, W), d_{S_i}((\Psi_i(n), s + t_0), (\Psi_i(m), s + t_0)) \leq_{k,c,\varkappa} 1$

Furthermore, for all $n \in N_i$, $\tilde{\Phi}_i(V_n) = V_{\Psi_i(n)}$ hence $\tilde{\Phi}_i(V_n)$ is a vertical geodesics of S_i . Then there exists $M(k, c, \varkappa)$ such that

$$(h_{\text{Div}}(V, W) + t_0) - M \leq h_{\text{Div}}(\tilde{\Phi}_i(V), \tilde{\Phi}_i(W)) \leq (h_{\text{Div}}(V, W) + t_0) + M.$$

Consequently Lemma 10.3.3 provides us with

$$\begin{aligned}
d_H(\Psi_i(n), \Psi_i(m)) &\asymp_{k,c,\varkappa} \exp(h_{\text{Div}}(V_{\Psi_i(n)}, W_{\Psi_i(m)})) = \exp(h_{\text{Div}}(\tilde{\Phi}_i(V), \tilde{\Phi}_i(W))) \\
&\asymp_{k,c,\varkappa} \exp(t_0) \exp(h_{\text{Div}}(V, W)) \\
&\asymp_{k,c,\varkappa} \exp(t_0) d_H(n, m), \quad \text{ by Lemma 10.3.3.}
\end{aligned}$$

Where t_0 depends only on Φ . Hence, $\Psi_i : (N_i, d_H) \rightarrow (N_i, d_H)$ is bi-Lipschitz. □

Proof of Theorem 10.3.2: Let Ψ_1, Ψ_2 be as in Theorem 10.2.3, and let f be the application

$$\begin{aligned}
f : \text{QI}((N_1 \times N_2) \times_A \mathbb{R}) / \sim &\rightarrow \text{Bilip}(N_1) \times \text{Bilip}(N_2) \\
\Phi &\mapsto (\Psi_1, \Psi_2)
\end{aligned}$$

We first show that this application is well defined. Let $\Phi, \Phi' \in \text{QI}((N_1 \times N_2) \times_A \mathbb{R})$ be such that $\Phi \sim \Phi'$, which means that $d_{\varkappa}(\Phi, \Phi') \leq_{k,c,\varkappa} 1$.

By Theorems 10.2.3 and 10.3.4, there exist $\Psi_i, \Psi'_i \in \text{Bilip}(N_i)$ such that:

1. $d(\Phi, (\Psi_1, \Psi_2, \text{id}_{\mathbb{R}})) \leq_{k,c,\varkappa} 1$
2. $f(\Phi) = (\Psi_1, \Psi_2)$

3. $d(\Phi', (\Psi'_1, \Psi'_2, \text{id}_{\mathbb{R}})) \leq_{k,c,\varkappa} 1$
4. $f(\Phi') = (\Psi'_1, \Psi'_2)$

By the definition of Ψ_i and Ψ'_i , for all $n \in N$ we have

$$\begin{aligned}\Psi_i(n) &= P(V'_n(0)) \\ \Psi'_i(n) &= P(V''_n(0))\end{aligned}$$

Where V'_n the unique vertical geodesic close to $\hat{\Phi}_i(V_n)$ and V''_n the unique vertical geodesic close to $\hat{\Phi}'_i(V_n)$. However $\Phi \sim \Phi'$, then $\hat{\Phi}_i(V_n)$ and $\hat{\Phi}'_i(V_n)$ are M -close to each other for some $M(k, c, \varkappa)$, therefore $d_{\text{Hff}}(V'_n, V''_n) \leq_{k,c,\varkappa} 1$. However these vertical geodesics are unique, then $V'_n = V''_n$. Consequently, $\Psi_i(n) = \Psi'_i(n)$, hence $\Psi_i = \Psi'_i$, therefore f is well defined.

Let us now prove that f is injective. Let Φ and Φ' be two quasi-isometries of $(N_1 \times N_2) \rtimes_A \mathbb{R}$ such that $f(\Phi) = f(\Phi')$. Then by Theorem 10.2.3 and by the triangle inequality

$$d_{\varkappa}(\Phi, \Phi') \leq d_{\varkappa}(\Phi, (\Psi_1, \Psi_2, \text{id}_{\mathbb{R}})) + d_{\varkappa}((\Psi_1, \Psi_2, \text{id}_{\mathbb{R}}), \Phi') \leq_{k,c,\varkappa,\Phi,\Phi'} 1.$$

Hence $\Phi \sim \Phi'$, which proves that f is injective.

Let $\Psi_i \in \text{Bilip}(N_i, d_H)$, our goal is to show that $(\Psi_i, \text{id}_{\mathbb{R}})$ is a quasi-isometry of $(N_i \rtimes_A \mathbb{R}, d_{S_i})$. Let $(n, t_n), (m, t_m) \in S_i$. By Lemma 10.3.3 applied on n and m , there exists a constant $M(k, c, \varkappa)$ such that

$$\ln(d_H(n, m)) - M \leq h_{\text{Div}}(V_n, V_m) \leq \ln(d_H(n, m)) + M. \quad (10.10)$$

Similarly, by Lemma 10.3.3 applied on $\Psi_i(n)$ and $\Psi_i(m)$

$$\ln(d_H(\Psi_i(n), \Psi_i(m))) - M \leq h_{\text{Div}}(V_{\Psi_i(n)}, V_{\Psi_i(m)}) \leq \ln(d_H(\Psi_i(n), \Psi_i(m))) + M. \quad (10.11)$$

However by Theorem 10.3.4 $\Psi_i \in \text{Bilip}(N_i, d_H)$ hence $d_H(n, m) \asymp d_H(\Psi_i(n), \Psi_i(m))$. Therefore by inequalities (10.10) and (10.11) we have

$$|h_{\text{Div}}(V_n, V_m) - h_{\text{Div}}(V_{\Psi_i(n)}, V_{\Psi_i(m)})| \leq 1. \quad (10.12)$$

Moreover by Lemma 6.0.2 we can characterise the distance between two points thanks to the height of divergence of their associated vertical geodesics. Let us denote $h_0 = h_{\text{Div}}(V_n, V_m)$. By inequality (10.12) and by Lemma 6.0.2, if $h_0 \geq \max(t_n, t_m)$ we have both:

$$\begin{aligned}\left|d_{S_i}((n, t_n), (m, t_m)) - (|t_m - h_0| + |t_n - h_0|)\right| &\leq_{\delta} 1 \\ \left|d_{S_i}((\Psi_i(n), t_n), (\Psi_i(m), t_m)) - (|t_m - h_0| + |t_n - h_0|)\right| &\leq_{\delta} 1\end{aligned}$$

Consequently by the triangle inequality there exists $M(\delta)$ such that

$$d_{S_i}((n, t_n), (m, t_m)) - M \leq d_{S_i}((\Psi_i(n), t_n), (\Psi_i(m), t_m)) \leq d_{S_i}((n, t_n), (m, t_m)) + M$$

Similarly, if $h_0 \leq \max(t_n, t_m)$ we have both:

$$\begin{aligned}\left|d_{S_i}((n, t_n), (m, t_m)) - (|t_m - t_n|)\right| &\leq_{\delta} 1 \\ \left|d_{S_i}((\Psi_i(n), t_n), (\Psi_i(m), t_m)) - (|t_m - t_n|)\right| &\leq_{\delta} 1\end{aligned}$$

Hence again

$$d_{S_i}((n, t_n), (m, t_m)) - M \leq d_{S_i}((\Psi_i(n), t_n), (\Psi_i(m), t_m)) \leq d_{S_i}((n, t_n), (m, t_m)) + M$$

Therefore $(\Psi_i, \text{id}_{\mathbb{R}})$ is a $(1, M)$ -quasi-isometry of $N_i \rtimes \mathbb{R}$, hence $(\Psi_1, \Psi_2, \text{id}_{\mathbb{R}})$ is also a $(1, M)$ -quasi-isometry, which provides us with $f(\Psi_1, \Psi_2, \text{id}_{\mathbb{R}}) = (\Psi_1, \Psi_2)$. Hence f is surjective, and finally bijective.

Let us now prove that f is a morphism. Let $\Phi, \Phi' \in \text{QI}((N_1 \times N_2) \rtimes_A \mathbb{R})$. Furthermore, $d_{\mathfrak{M}}(\Phi', (\Psi'_1, \Psi'_2, \text{id}_{\mathbb{R}})) \leq 1$, hence $d_{\mathfrak{M}}(\Phi \circ \Phi', \Phi \circ (\Psi'_1, \Psi'_2, \text{id}_{\mathbb{R}})) \leq 1$ since Φ is a quasi-isometry. Moreover, $d_{\mathfrak{M}}(\Phi, (\Psi_1, \Psi_2, \text{id}_{\mathbb{R}})) \leq 1$, therefore by the triangle inequality

$$d_{\mathfrak{M}}(\Phi \circ \Phi', (\Psi_1, \Psi_2, \text{id}_{\mathbb{R}}) \circ (\Psi'_1, \Psi'_2, \text{id}_{\mathbb{R}})) \leq 1.$$

However

$$(\Psi_1, \Psi_2, \text{id}_{\mathbb{R}}) \circ (\Psi'_1, \Psi'_2, \text{id}_{\mathbb{R}}) = (\Psi_1 \circ \Psi'_1, \Psi_2 \circ \Psi'_2, \text{id}_{\mathbb{R}}),$$

which provides us with

$$d_{\mathfrak{M}}(\Phi \circ \Phi', (\Psi_1 \circ \Psi'_1, \Psi_2 \circ \Psi'_2, \text{id}_{\mathbb{R}})) \leq 1.$$

Consequently $f(\Phi \circ \Phi') = (\Psi_1 \circ \Psi'_1, \Psi_2 \circ \Psi'_2)$. □

In this proof we showed that $\Phi \sim (\Psi_1, \Psi_2, \text{id}_{\mathbb{R}})$, therefore any quasi-isometry is in the equivalence class of an $(1, M)$ -quasi-isometry.

Bibliography

- [1] L. BARTHOLDI, M. NEUHAUSER, W. WOESS, *Horocyclic products of trees*. Journal European Mathematical Society, Volume 10 (2008) 771-816.
- [2] A. BENDIKOV, L. SALOFF-COSTE, M. SALVATORI, W. WOESS, *Brownian motion on treebolic space: escape to infinity*. Revista Matemática Iberoamericana. European Mathematical Society Publishing House, Volume 31.3 (2015), 935-976.
- [3] M.R. BRIDSON, A. HAEFLIGER, *Metric Spaces of Non-Positive Curvature*. Grundlehren der Mathematischen Wissenschaften [Fundamental Principles of Mathematical Sciences]. Springer-Verlag, Berlin, Volume 319 (1999).
- [4] S. BROFFERIO, M. SALVATORI, W. WOESS, *Brownian Motion and Harmonic Functions on $Sol(p, q)$* . International Mathematics Research Notices, Volume 22 (2011) 5182–5218.
- [5] M. COORNAERT, T. DELZANT, A. PAPADOPOULOS, *Géométrie et théorie des groupes: Les groupes hyperboliques de Gromov*. Lecture Notes in Mathematics 1441 (1990).
- [6] M.G. COWLING, V. KIVIOJA, E. LE DONNE, S. NICOLUSSI GOLO, A. OTTAZI, *From Homogeneous Metric Spaces to Lie Groups*. arXiv:1705.09648 (2021).
- [7] T. DYMARZ, *Large scale geometry of certain solvable groups*. Geometric and Functional Analysis, volume 19, 6 (2009), 1650-1687.
- [8] A. ESKIN, D. FISHER, *Quasi-isometric rigidity of solvable groups*. Proceedings of the International Congress of Mathematicians, Hyderabad, India, (2010).
- [9] A. ESKIN, D. FISHER, K. WHYTE, *Quasi-isometries and rigidity of solvable groups*. Pure and Applied Mathematics Quaterly Volume 3 Number 4 (2007), 927-947.
- [10] A. ESKIN, D. FISHER, K. WHYTE, *Coarse differentiation of quasi-isométries I: Spaces not quasi-isometric to Cayley graphs*. Annals of Mathematics Volume 176 (2012), 221-260.
- [11] A. ESKIN, D. FISHER, K. WHYTE, *Coarse differentiation of quasi-isométries II: rigidity for lattices in Sol and lamplighter groups*. Annals of Mathematics Volume 177 (2013), 869-910.
- [12] B. FARB, L. MOSHER, *A rigidity theorem for the solvable Baumslag-Solitar groups*. Invent. math. 131 (1998),419-451.
- [13] B. FARB, L. MOSHER, *Quasi-isometric rigidity for the solvable Baumslag-Solitar groups II*. Invent. math. 137 (1999),613-649.
- [14] T. FERRAGUT, *Geodesics and Visual boundary of Horospherical Products*. arXiv:2009.04698 (2020).
- [15] T. FOERTSCH, A. LYTCHAK, V. SCHROEDER, *Nonpositive Curvature and the Ptolemy Inequality*. International Mathematics Research Notices Volume 2007 (2007).

- [16] E. GHYS, P. DE LA HARPE, *Sur les Groupes Hyperboliques d'après Mikhael Gromov*. Progress in Mathematics Volume 83 (1990).
- [17] S. GOUËZEL, V. SHCHUR, *A corrected quantitative version of the Morse lemma* Journal of Functional Analysis, Volume 277 (2019) 1258-1268.
- [18] M. GROMOV, *Asymptotic invariants of infinite groups* LMS Lecture Notes, vol. 182, Cambridge Univ. Press, (1993).
- [19] J. HEINONEN, *Lectures on analysis on metric spaces*. Universitext. Springer-Verlag, New York, (2001).
- [20] E. HEINTZE, *On homogeneous manifolds of negative curvature*. Mathematische Annalen. Vol.211; Iss. 1 (1974).
- [21] M. KAPOVICH, *Lectures on quasi-isometric rigidity*. Geometric Group Theory . vol.21. (2014), 127-172.
- [22] A. PAPAPOPOULOS, *Metric spaces, convexity and nonpositive curvature*. IRMA Lectures in Mathematics and Theoretical Physics 6 (2004).
- [23] I. PENG, *Coarse differentiation and quasi-isometries of a class of solvable Lie groups I*. Geom. Topol. 15, No. 4, (2011), 1883-1925.
- [24] I. PENG, *Coarse differentiation and quasi-isometries of a class of solvable Lie groups II*. Geom. Topol. 15, (2011), 1927-1981.
- [25] P.M. SOARDI, W. WOESS, *Amenability, unimodularity, and the spectral radius of random walks on infinite graphs*. Math. Z. 205 (1990), 471-486.
- [26] M. TROYANOV, *L'horizon de SOL*. EPFL, Exposition. Math. Volume 16 (1998), 441-479.
- [27] W. WOESS, *Lamplighters, Diestel-Leader Graphs, Random Walks, and Harmonic Functions*. Institut für Mathematik C, Technische Universität Graz Steyrergasse 30, Combinatorics, Probability & Computing 14 (2005) 415-433.
- [28] W. WOESS, *What is a horocyclic product, and how is it related to lamplighters?* Internationale Mathematische Nachrichten, Volume 224 (2013) 1-27.
- [29] X. XIE, *Large scale geometry of negatively curved $\mathbb{R}^n \rtimes \mathbb{R}$* . Geom. Topol. 18, No. 2 (2014), 831-872.