



HAL
open science

Methodological framework for a digital thread between product lifecycle management and internet of things : application to the manufacturing industry

Piers Barrios

► To cite this version:

Piers Barrios. Methodological framework for a digital thread between product lifecycle management and internet of things : application to the manufacturing industry. Eco-conception. Université de Technologie de Compiègne, 2022. English. NNT : 2022COMP2759 . tel-04665981

HAL Id: tel-04665981

<https://theses.hal.science/tel-04665981v1>

Submitted on 1 Aug 2024

HAL is a multi-disciplinary open access archive for the deposit and dissemination of scientific research documents, whether they are published or not. The documents may come from teaching and research institutions in France or abroad, or from public or private research centers.

L'archive ouverte pluridisciplinaire **HAL**, est destinée au dépôt et à la diffusion de documents scientifiques de niveau recherche, publiés ou non, émanant des établissements d'enseignement et de recherche français ou étrangers, des laboratoires publics ou privés.

Par Piers BARRIOS

Methodological framework for a digital thread between product lifecycle management and internet of things: application to the manufacturing industry

Thèse présentée
pour l'obtention du grade
de Docteur de l'UTC

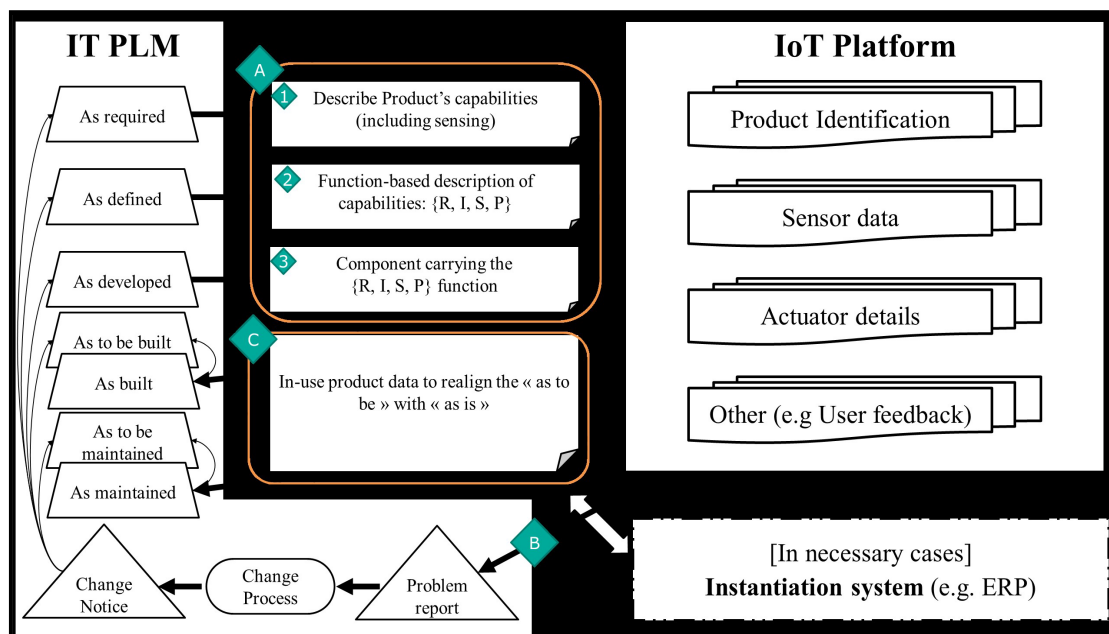

Soutenue le 13 décembre 2022

Spécialité : Génie Industriel : Unité de recherche en Mécanique -
Laboratoire Roberval (FRE UTC - CNRS 2012)

D2759

UNIVERSITE DE TECHNOLOGIE DE COMPIEGNE

Thèse présentée pour l'obtention du grade de docteur
de l'Université de Technologie de Compiègne

**Methodological Framework for a Digital Thread between
Product Lifecycle Management and Internet of Things:
application to the Manufacturing Industry**

Par **Piers BARRIOS**

Spécialité : Génie Industriel

Département d'Ingénierie Mécanique – Laboratoire Roberval

Soutenue le 13 décembre 2022 devant le jury composé de :

Nadège TROUSSIER, Présidente, Arts & Métiers

Christophe DANJOU, Codirecteur de recherche, Polytechnique Montréal

Benoit EYNARD, Codirecteur de recherche, Université de Technologie de Compiègne

Vincent CHEUTET, Rapporteur, Institut National des Sciences Appliquées de Lyon

Dimitris KIRITSIS, Rapporteur, École polytechnique fédérale de Lausanne

Matthieu BRICOGNE-CUIGNIÈRES, Examinateur, Université de Technologie de Compiègne

Johan MALMQVIST, Examinateur, Chalmers University of Technology

Monica ROSSI, Examinatrice, Politecnico di Milano

Xavier GODART & José RIOS, Invités

DEDICATION

Et al.

Standing on the shoulders of giants

Des nains sur des épaules de géants

RESUME

Depuis son émergence il y a deux décennies, la gestion du cycle de vie des produits (PLM) a façonné le développement de produits et l'ingénierie de production tout en aidant à accélérer considérablement les processus et opérations. De plus, les objets connectés (IoT) sont actuellement en très forte émergence et l'intérêt qui y est porté de plus en plus croissant. Étonnamment, les interactions entre les plateformes IoT et logiciels PLM sont très rares à ce jour. Les industriels ont permis quelques connexions là où le retour sur investissement était élevé et certain. Cependant, le défi pour l'intégration de ces systèmes demeure conséquent.

L'intégration des deux systèmes est essentielle pour tirer le meilleur parti des données collectées par divers capteurs pendant la fabrication, l'utilisation, la maintenance et les défaillances du produit. Ces données seront ensuite exploitées afin d'améliorer la conception, la fabrication, le maintien en condition opérationnel ou le retrait de service du produit actuel, de la gamme de produits ou d'un futur produit, créant ainsi une boucle de rétroaction vertueuse permettant des produits plus durables via la servicisation des produits ou le paiement à l'utilisation.

La problématique de cette thèse est « Comment lier les informations de gestion du cycle de vie des produits, notamment les informations d'ingénierie, et les données des objets connectés, quels qu'ils soient, dans un contexte d'industrie manufacturière discrète ? » Tout d'abord, cette thèse présente l'état de l'art actuel des méthodologies existantes, du PLM, de l'IoT et de l'interopérabilité et détaille la problématique en une question de recherche plus précise : « Quel méthodologie pourrait être utilisée pour développer une solution prête pour l'industrie afin d'assurer une continuité numérique entre le PLM et l'IoT ? » Cette thèse propose ainsi un cadre méthodologique pour une continuité numérique entre PLM et IoT basé sur quatre concepts clés et trois approches novatrices. Les quatre concepts clés sont les configurations de référence, la gestion des modifications, l'instanciation du produit et la structuration des données IoT. Les trois nouvelles approches sont l'orientation fonctionnel du PLM (basé sur des fonctions de réaction, d'interfaçage, de stockage et de traitement des données), le rapport de problème en tant que medium et l'enrichissement des configurations de référence dite « comme devrait être ». Ensuite, ce cadre méthodologique est validé sur des cas d'utilisation basés sur la bouteille intelligente REBO. Enfin, la discussion porte sur l'extension possible du cadre à d'autres industries et métiers.

ABSTRACT

Since its emergence two decades ago, Product Lifecycle Management (PLM) has shaped product development and production engineering while helping achieve a tremendous quickening in processes and operations. On the other hand, Internet of Things (IoT) is currently in extraordinarily strong emergence and overall interest is increasingly growing. Surprisingly, interactions between IoT platforms and PLM software are very scarce to this day. The industry has enabled a few connections when and where return on investment was high and certain. However, nowadays, the struggle for systems integration remains.

The two systems' integration is key to make the most of the data collected by various sensors about a product's manufacturing, usage, maintenance, and failures, namely its lifecycle. This data will then be exploited to improve either conception, manufacturing, servicing, or disposal of either the current product, the product range or a future product therefore creating a virtuous feedback loop enabling more sustainable products via product servitisation or pay-per-use.

This thesis' problem statement is "How to link product lifecycle management information, especially engineering information, and data from smart things, whatever they are, in a discrete manufacturing industry context?" First, it presents the current state-of-the-art of existing methodologies, PLM, IoT and Interoperability and phrases the research question: "What framework could be used to develop an industry-ready solution to ensure a digital thread between PLM software and IoT Platform?" This thesis then proposes a methodological framework for a digital thread between PLM and IoT based on four key concepts and three novel approaches. The four key concepts are Baselines, Change Management, Product Instantiation and IoT information structuration. The three novel approaches are Function-enabled PLM (based on reacting, interfacing, storing and data processing functions), Problem report as a medium, and Enrichment of 'as to be' baselines. Thirdly, it is validated upon use cases based on the REBO smart bottle. Finally, discussion covers the possible extension of the framework over other industries and trades.

TABLE OF CONTENTS

DEDICATION	III
RESUME.....	IV
ABSTRACT	V
TABLE OF CONTENTS	VI
LIST OF TABLES	X
LIST OF FIGURES.....	XI
LIST OF SYMBOLS AND ABBREVIATIONS.....	XIV
LIST OF APPENDICES	XVI
CHAPTER 1 INTRODUCTION.....	1
1.1 Product servitisation and pay to use: A global trend that could help fight climate crisis? 1	
1.1.1 World Economic Forum’s perspective.....	2
1.1.2 United Nation’s perspective	5
1.1.3 A global lack of technological roadmap from IGOs for tooling product Servitisation in order to tackle climate crisis	5
1.2 Research positioning: IoT or IIoT?	7
1.2.1 IoT and IIoT definitions	7
1.2.2 IoT as the global research position.....	15
1.3 Problem statement	16
1.3.1 Industrial context.....	17
1.3.2 Scientific context.....	17
1.3.3 Phrasing the problem statement	18

1.4	Thesis structure	20
CHAPTER 2 STATE OF THE ART.....		21
2.1	Lack of an existing suitable modelling	21
2.1.2	Missing a suitable methodology or architecture	39
2.2	PLM and IT PLM	39
2.2.1	PLM from academia perspective.....	39
2.2.2	PLM as in PLM software	45
2.2.3	IT PLM key concepts for the proposed methodological framework	47
2.2.4	Reflecting PLM and IT PLM on the problem statement.....	55
2.3	IoT and IoT Platforms	56
2.3.1	IoT Platform features and choice help: (Santana et al., 2021)'s findings	56
2.3.2	Joint literature on PLM and IoT	58
2.3.3	The fourth key feature for the proposition: IoT Information Structuration	62
2.3.4	Reflecting IoT on the problem statement.....	62
2.4	Interoperability	63
2.4.1	Semantic interoperability	64
2.4.2	About the difficulty of migrating a PLM system	66
2.5	Digital Twin and Cyber-Physical Systems.....	67
2.5.2	Cyber-Physical Systems	69
2.6	State of the art synthesis and scientific research question	70
CHAPTER 3 PROPOSITION.....		73
3.1	Four key concepts from PLM and IoT	74
3.1.1	Four key concepts and their respective positioning	74
3.1.2	Concepts' Structuration.....	77

3.2	[First novel approach: A] Function-enabled PLM	78
3.2.1	The four functions	79
3.2.2	A1: As Required: Describe Product’s capabilities (including sensing)	81
3.2.3	A2: As Defined: Function-based description of capabilities: {React, Interface, Store, Process}	81
3.2.4	A3: As Developed: Component carrying the {Reacting, Interfacing, Storing, Data Processing} function	81
3.2.5	Further baselines: minor changes	82
3.3	[2 nd Novel Approach: B] Problem report (and change management) as a medium.....	83
3.4	[3 rd Novel Approach: C] Enrichment of ‘As to be’ baselines	84
3.5	Verification and Validation criteria.....	85
3.5.1	Verification criteria	85
3.5.2	Validation criteria.....	86
3.6	Synthesis and proposition wrap-up	87
CHAPTER 4 INDUSTRIAL READINESS OF METHODOLOGICAL FRAMEWORK		88
4.1	Implementation guideline.....	88
4.1.1	Choice of platforms	88
4.1.2	Interaction mode.....	90
4.1.3	Function-enabled PLM.....	92
4.1.4	Problem report as a medium.....	94
4.2	On the effort to implement	96
4.3	Verification.....	97
CHAPTER 5 VALIDATION ON A CASE STUDY		98
5.1	Presentation of the case-study: REBO Smart Bottle.....	98

5.2	The REBO baselines	99
5.2.1	As Required.....	99
5.2.2	As Developed	103
5.3	Use-cases.....	106
5.3.1	Three real use-cases	106
5.3.2	Theoretical use-cases.....	108
5.4	Validation	108
CHAPTER 6	DISCUSSION	110
6.1	On the reproducibility of the Industrial readiness.....	110
6.2	Limits to validation	110
6.3	On the adaptability of the methodological framework.....	111
6.3.1	Product complexity	112
6.3.2	Support complexity	112
6.3.3	Typology of actors	113
6.4	A contribution to the Digital Twin.....	113
6.5	Synthesis and discussion wrap-up.....	114
CHAPTER 7	CONCLUSION (AND FUTURE WORK).....	115
AUTHOR'S WORK	118
REFERENCES	120

LIST OF TABLES

Table 1. IoT definition of normative bodies in regard of features addressed	12
Table 2. Juxtaposition of Descartes’s analytical method and Le Moigne’s systemic method, according to (Eriksson, 1997)	22
Table 3. Le Moigne’s systemic method principles and their definition, according to (Eriksson, 1997).....	23
Table 4. ITIL v4’s 34 practices by type	30
Table 5. Parallels between ERP and PLM established by (Silventoinen et al., 2011)	40
Table 6. “Four grand challenges in next generation enterprise information systems” from (El Kadiri et al., 2016).....	44
Table 7. IoT Platforms features according to articles, translated from (Santana et al., 2021)	57
Table 8. Systematic literature review keywords and search requests, from (Barrios et al., 2022)	60
Table 9. Table of criteria for SLR, from (Barrios et al., 2022)	61

LIST OF FIGURES

Figure 1-1. “The adoption and impact path of the Industrial Internet”, according to (World Economic Forum, 2015).....	4
Figure 1-2. “Entity-based IoT Reference Model” from (ISO/IEC 30141:2018, 2018)	11
Figure 2-1. “Zachman Framework” from Wikimedia.....	25
Figure 2-2. “Relations of the Automatability, Humanizability and Extent of Automation lines in defining the human and organizational architecture,” from (Williams, 1994)	27
Figure 2-3. “Reference model of smart manufacturing in the context of the industrial IoT in the product life-cycle view”, according to (ITU-T Y.4003, 2018)	32
Figure 2-4. “Industrial Internet Architecture Viewpoints”, according to (Industrial Internet Consortium, 2019, p. 1), illustration from IIC	34
Figure 2-5. “Reference Architectural Model Industrie 4.0 (RAMI 4.0)”	35
Figure 2-6. “Applications and techniques associated with each level of the 5C architecture.” From (Lee et al., 2015)	36
Figure 2-7. “Functional mapping among 5C Architecture, IIRA and RAMI 4.0.”, from (Pivoto et al., 2021).....	38
Figure 2-8. “Evaluation of PLM systems of different companies from the proposed model.”, from (Enríquez et al., 2019)	47
Figure 2-9. “Product data”, from (Pinquié et al., 2015)	50
Figure 2-10. An engineering change process overview	51
Figure 2-11. A change process example	53
Figure 2-12. “Product”, from (Pinquié et al., 2015).....	54
Figure 2-13. “The essence of product type and product instance and the four processes of interaction between them”, from (Nyffenegger et al., 2018)	55

Figure 2-14. Number of journal articles per category per year, from (Barrios et al., 2019a)	59
Figure 2-15. SLR process steps with associated results, from (Barrios et al., 2022).....	61
Figure 2-16. Number of articles per category per year in (Barrios et al., 2022).....	62
Figure 2-17. “Interoperability Model”, from (European Commission. DGI., 2017)	64
Figure 2-18. Interoperability Model, adapted from (European Commission. DGI., 2017) & (ISO 14258:1998, 1998)	65
Figure 2-19. Maturity Model for Data-Driven Manufacturing, from (Weber et al., 2017)	68
Figure 2-20. Digital Model, Shadow, and Twin, according to & adapted from (Kritzinger et al., 2018).....	69
Figure 2-21. “Transition process from Mechatronics to CPS to Internet of Things.”, from (Hehenberger et al., 2016).....	70
Figure 3-1. Representation of configuration baseline	74
Figure 3-2. Representation of change management	75
Figure 3-3. Representation of product instantiation.....	76
Figure 3-4. Representation of all three PLM concepts.....	76
Figure 3-5. Representation of IoT Information Structuration	77
Figure 3-6. Representation of all four PLM and IoT concepts	78
Figure 3-7. The four functions necessary to implement in products.....	80
Figure 3-8. Adding function-enabled components (A1, A2, A3) to the framework.....	82
Figure 3-9. Adding Problem Report feedback loop (B) to the framework	84
Figure 3-10. Adding Enrichment of ‘As to be’ baselines (C) to the framework.....	85
Figure 4-1. List of constraints than can be applied on soft attributes (Windchill screenshot).....	89
Figure 4-2. Demonstrator architecture outline between Windchill and ThingWorx	90
Figure 4-3. Windchill API response: a JSON containing information about the root assembly, subassemblies, and parts.	91

Figure 4-4. Type and Attribute Management Admin panel where subtypes can be created (Windchill screenshot)	93
Figure 4-5. Windchill’s internal problem report workflow.....	94
Figure 4-6. Illustration of new "Report a Problem" feature from ThingWorx 9.2 announcement	95
Figure 5-1. Commercial illustration of the REBO bottle	99
Figure 5-2. As Required elements from the crowdfunding website (Indiegogo, 2022).....	100
Figure 5-3. CAD model of the REBO bottle.....	103
Figure 5-4. Draft design of the REBO app.....	104
Figure 5-5. Dashboard enabling Blockchain credit generation.....	105
Figure 5-6. Survey excerpt enabling REBO Silicone Lace replacement	106
Figure 6-1. “Product classification depending on product complexity and industrial strategies”, from (Barrios et al., 2022).....	112
Figure 7-1. The Methodological Framework for a Digital Thread between PLM and IoT	116

LIST OF SYMBOLS AND ABBREVIATIONS

This list presents the symbols and abbreviations used in the thesis in alphabetical order, along with their meanings.

APS	Advanced Planning System
BIM	Building Information Modelling
BLE	Bluetooth Low Energy
BOM	Bill of Materials
BU	Business Unit
CIM	Computer Integrated Manufacturing
CMMS	Computerized Maintenance Management System
CN	Change Notice
CO	Change Order
CP	Change Proposal
CPS	Cyber-Physical System
CR	Change Request
DT	Digital Twin
EBOM	Engineering Bill of Materials
ERP	Enterprise Resource Planning
EM	Enterprise Modelling
GDPR	General Data Protection Regulation
GERA	Generalized Enterprise Referencing Architecture
GERAM	Generalized Enterprise-Referencing Architecture and Methodology
GIM	GRAI Integrated Methodology

GRAI	Graphs with Results and Actions Inter-related
ICT	Information and Communication Technology
IEC	International Electrotechnical Commission
IEEE	Institute of Electrical and Electronics Engineers
IGO	Intergovernmental Organization
IIoT	Industrial Internet of Things
IoT	Internet of Things
IPCC	Intergovernmental Panel on Climate Change
ISO	International Organization for Standardization
IT	Information Technology
ITU	International Telecommunication Union
MBOM	Manufacturing Bill of Materials
MES	Manufacturing Execution System
MPM	Manufacturing Process Management
OME	Observable Manufacturing Element (ISO/FDIS 23247, 2021)
PERA	Purdue Enterprise Reference Architecture
PDM	Product Data Management
PLM	Product Lifecycle Management
PR	Problem Report
RFC	Request for Change
ROI	Return on Investment
SBOM	Service Bill of Materials
SLR	Systematic Literature Review
TBD	To be Decided

TOF Time of Flight
WOS Web of Science

LIST OF APPENDICES

Appendix A Definitions of IoT and IIoT from Standardisation Bodies 1
Appendix B Definitions of PLM and PLM software 2

CHAPTER 1 INTRODUCTION

Internet of Things (IoT) has been around for a decade with, from the start, promises of exponential growth. One can notice thanks to the current electronic component shortage that this exponential growth was unachievable from the start. Nonetheless, growth has been sustained and numerous devices are landing on the market every day. The question is less about “Do you have smart connected devices?” than “How many do you have?” as cell phones, connected devices and wireless sensors are now common ground. Some have even become era icons such as Nabaztag (2005), Apple iPhone (2007), Nest (2011), Philips Hue (2011) and Amazon Alexa (2014). However, no IoT device has known a similar success in Industry as there is currently no straightforward way to connect smart connected devices with the company’s Information and Communication Technology (ICT) systems. A component of these enterprise ICT systems is Product Lifecycle Management (PLM). Originally coming from the 1980’s document management system and the 1990’s product data management, PLM tackles taking care of product information (Sudarsan et al., 2005).

In this introduction, we shall look towards why ensuring a digital thread between PLM and IoT may be interesting from an economical and necessary from an environmental point of view. Then we will position our research work concerning IIoT and IoT terminology, presenting the author’s context as well as outlining the research question before closing this chapter by exposing the research methodology.

1.1 Product servitisation and pay to use: A global trend that could help fight climate crisis?

The Paris Agreement sets as a goal to limit global warming to well below 2, preferably to 1.5 degrees Celsius, compared to pre-industrial levels (United Nations, 2016). Intergovernmental Panel on Climate Change (IPCC) increased global warming estimation to 2100 estimation to 3°C with a *likely* range of 2.5°C to 4°C (Masson-Delmotte et al., 2021). We as humankind therefore need to centre our activities towards this goal to tackle climate change. “The Limits to Growth” anchored the fact that the planet’s resources are scarce and therefore that growth is limited (Meadows & Club of Rome, 1972). Therefore, we as humankind are going to need to do better with less. This implies that we need to make more value out of what we currently have as physical resources; this could

be achieved through retrofitting current equipment or products - as more value is extracted from the same raw materials - for instance, equipping these with new sensors and/or actuators. However, these will need to be integrated, controlled, and monitored.

Economically speaking, a switch between product selling and service selling needs to happen in order to tackle the new challenges ahead, first of which is the climate crisis. Servitisation is the delivery of a service component as an added value, when providing products (Mahut et al., 2017). This switch may happen in multiple phases such as pay-to-use and further in time by a pay-per-outcome. Until now, only very few industrial use-cases existed in a pay-per-use model: Michelin¹ has a “pay by the mile” offering and Safran Helicopter Engines² has a “Pay as you fly” offering. However, lack of status knowledge about the in-use product limits the emergence of new use-cases. This might be overcome by the introduction of smart connected devices enabling a product data feedback loop.

Through this introduction, we shall first explore the World Economic Forum’s perspective, which turns out to be deceiving and deceptive for it seems aboveground, before secondly moving on to United Nation’s one, which turns out to give a broad objective but lacks indicators and a technological roadmap. Finally, we shall conclude this section on the fact that InterGovernmental Organizations (IGO) are lacking perspectives on how to make the most of product Servitisation from a technological point of view and how this research will aim to contribute to this lack.

1.1.1 World Economic Forum’s perspective

1.1.1.1 Offer evolution towards “new products and services”

The World Economic Forum (2015) depicts four phases on the path of adoption of Industrial Internet as outlined in Figure 1-1 below: Operational Efficiency, New Products & Services, Outcome Economy and finally Autonomous, Pull Economy. The first two are labelled as “Near-

¹<https://business.michelinman.com/freight-transportation/freight-transportation-services/michelin-fleet-solutions>, last accessed on July 20, 2021

²<https://www.safran-helicopter-engines.com/services/cost-control-and-availability>, last accessed on July 20, 2021

term” and the last two are labelled as “Long-term”, without, however, giving any range of time. As Operational Efficiency is already a core part of current developments of Industry 4.0 (Schuh et al., 2020), we shall not dive further into it. New Products & Services are, however, interesting to dive into as none of the examples given by the World Economic Forum (2015) are new products: indeed, pay-per-use, software-based services and data monetization are only service-oriented and do not constitute any new products. This demonstrates a trend of limited possibilities for new products, and a replacement by services in the global economy. One could argue that this phase of New Products & Services has already started as the subscription economy with offers such as Prime Video (Amazon) or Netflix for video streaming, or Deezer and Spotify for music listening are already well established. However, these are not at all in a pay-per-use model and only induce an expansion in the consumption of resources known as the Jevon paradox or rebound effect (York & McGee, 2016).

Moreover, data monetization is core to an economic war between world powers as concerns over data protection and privacy regulations are generalizing: (GDPR, 2016) in the European Union has paved the way for data protection worldwide and many countries are to follow such as India (Personal Data Protection Bill, 2019) and more recently China (Personal Information Protection Law, 2021). In this context, legal interoperability is key and leads to political systems negotiating with one another a data transfer framework such as the EU-USA one (European Commission, 2022). Finally, the “new services” phase as it should be renamed is still to come but would enable the shift from a product-oriented economy to a service-oriented one.

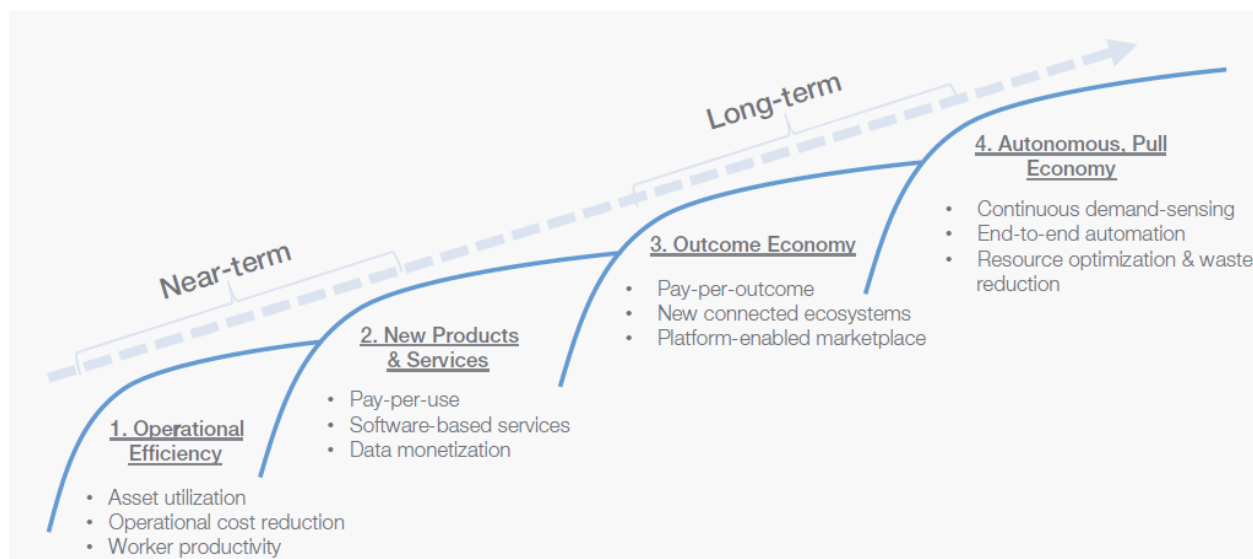

Figure 1-1. “The adoption and impact path of the Industrial Internet”,
according to (World Economic Forum, 2015)

1.1.1.2 An outcome economy and further

The outcome economy as depicted by the World Economic Forum (2015) encompasses pay-per-outcome, new connected ecosystems, and platform-enabled marketplace. However, the two latter are already well in place as Apple, Google and, more lately, Amazon ecosystems and marketplaces are hegemonic. This leaves us with the perspective of paying-per-outcome without having any precision however on how this outcome would be measured.

Similarly, the “autonomous, pull economy” does not provide any details as to how it is to be realized, measured, and eventually fulfilled despite announcing “resource optimization & waste reduction.”

Overall, throughout the document, the World Economic Forum has only superficially covered how Industrial Internet of Things would enable a change in the global economy despite advancing interesting perspectives about how the future might look. Moreover, regarding this perspective some argue that it is creating issues of privacy and the management of, and access to, individual personal data (Hehenberger et al., 2016).

1.1.2 United Nation's perspective

United Nation's sustainable development goals aim to a better and a more sustainable future for all³. In this list, Goal 9 entitled "Industries, Innovation and Infrastructure" focuses on a more respectful industry. It defines Target number 9.4 as follows:

“By 2030, upgrade infrastructure and retrofit industries to make them sustainable, with increased resource-use efficiency and greater adoption of clean and environmentally sound technologies and industrial processes, with all countries taking action in accordance with their respective capabilities.”

Moreover, the only associated indicator is “9.4.1: CO2 emission per unit of value added.” This enhances the idea of making more added value with less resources as CO2 emissions are linked with the amount and transformation of resources. However, the UN at no time paves the way for the technological route the world should follow to achieve these targets (Imaz & Sheinbaum, 2017).

1.1.3 A global lack of technological roadmap from IGOs for tooling product Servitisation in order to tackle climate crisis

To conclude this section, planet Earth's resources are well known to be limited and scarce but world level instances such as the World Economic Forum do not seem to take the matter into account while the United Nation's sustainable development goals demonstrate a better comprehension of the situation and aim for a more respectful industry. Based on these two perspectives, one shall conclude that there is global lack of technological roadmap from IGOs for tooling product Servitisation in order to tackle climate crisis. Throughout this PhD thesis, a better use of the existing PLM and IoT systems and the digital thread between them will aim to attain the very objective of making more with less. Hopefully paving a way for a more sustainable future than the currently forecasted one.

On a less optimistic note, we must however underline that Hickel & Kallis (2020) “conclude that green growth is likely to be a misguided objective, and that policymakers need to look toward

³<https://www.un.org/sustainabledevelopment/>, last accessed April 14, 2021

alternative strategies.” Overall, ICT emissions will not reduce unless political and industrial actions are undertaken; IoT has associated opportunities and threats linked to it. Indeed, IoT should substitute more carbon-intensive activities rather than act alongside them and not lead to any rebound effect for a virtuous way forward (Freitag et al., 2021). Overall, Industry still struggles to implement eco-design so far. To help with this, Dekoninck et al. (2016) develops a major framework to define those challenges for eco-design implementation and Quisbert-Trujillo et al. (2020) specifically addresses eco-design for IoT. In order to address those challenges, Bruel et al. (2019) suggests that addressing ecological economics along circular economy might improve global sustainability further than industrial ecology did so far. Finally, Industry 5.0 blows the whistle on global industrial transformation and emphasises the need to pursue human-centricity, sustainability, and resiliency (Leng et al., 2022).

1.2 Research positioning: IoT or IIoT?

While IoT stands for Internet of Things and IIoT stands for Industrial Internet of Things, neither one nor the other have yet reached a well-accepted definition throughout standards and literature. Therefore and prior to exposing further this thesis, one shall determine the relationship between IoT and IIoT, whether to encompass one or the other, or if, after all, the distinction does not stand meticulous scrutiny.

Throughout this section, we shall first go through a few definitions of IoT and IIoT from the normative bodies to highlight similarities and differences. Second, we explore a few definitions from academia to confront and challenge the previous results. Finally, we will explicit how IIoT is the use-case perspective and why IoT will be used to address the matter throughout this thesis as IIoT is most often used as “IoT in Industry,” not leading to any differentiation and misleading academia and practitioners alike.

1.2.1 IoT and IIoT definitions

Definitions for IoT, and somewhat for IIoT, are numerous and require some scrutiny to position this research in view of the global domain. First shall be explored the definitions given by the normative bodies before secondly looking into the academic literature for further matter.

1.2.1.1 By standards bodies

We shall list the definitions of a few but main standards bodies: ITU, IEEE and ISO/IEC before analysing them in the last sub subsection.

1.2.1.1.1 By the ITU (International Telecommunication Union)

“Overview of the Internet of things” (ITU-T Y.4000/Y.2060, 2012) defines IoT as “A global infrastructure for the information society, enabling advanced services by interconnecting (physical and virtual) things based on existing and evolving interoperable information and communication technologies.” Moreover, two notes are joined to the definition:

“NOTE 1 – Through the exploitation of identification, data capture, processing and communication capabilities, the IoT makes full use of things to offer services

to all kinds of applications, whilst ensuring that security and privacy requirements are fulfilled.

NOTE 2 – From a broader perspective, the IoT can be perceived as a vision with technological and societal implications.”

This definition and its associated notes, despite going back to a decade ago, outline the diversity of understandings concerning IoT through multiples facets: the infrastructure, its components, the associated use-cases as well as the holistic approach. Later definitions have been building on these elements.

“Overview of smart manufacturing in the context of the industrial Internet of things” (ITU-T Y.4003, 2018) refers to the previous definition for IoT and further defines IIoT as “An Internet of things based enabling approach for industrial transformation, by taking advantage of existing and emerging information and communication technologies.” Moreover, two notes are joined to the definition:

“NOTE 1 – Emerging information and communication technologies include technologies for smart machines, robots, advanced industrial networks, industrial cloud computing and industrial data processing.

NOTE 2 – The industrial transformation enabled by the industrial Internet of things empowers the industry with, but not limited to, improved efficiency, intelligent production, reduced energy consumption, advanced collaboration modes and new business models. Industrial Internet of things enables smart manufacturing providing enhanced capabilities in support of manufacturing.”

We can therefore notice that what is merely described as IIoT is no more and no less than IoT applied to Industry according to ITU.

On a side note and reflecting to the introduction, (ITU-T Y.4003, 2018)’s Appendix I outlines that an application example of IoT is the “transformation of the sales model from selling products to selling services”.

1.2.1.1.2 By the IEEE

IEEE's positioning on IoT definition is dual: on the one side, an initiative is working towards a definition while a standard issued by IEEE SA has a definition. The author reached out to IEEE for clarification (personal communication, August 2nd, 2021) and to date has not received any answer. Indeed, since 2015, the IEEE IoT initiative currently has an open topic about the definition of IoT⁴ and has issued a work document towards a definition (Minerva et al., 2015) with key features listed: interconnection of things, connection of things to the internet, uniquely identifiable things, ubiquity, sensing/actuation capability, embedded intelligence, interoperable communication capability, self-configurability, and programmability. IEEE IoT does not therefore have a definition for IoT.

However, IEEE Standards Association (IEEE SA) has proposed a definition for IoT. Currently, "IEEE Standard for an Architectural Framework for the Internet of Things (IoT) " (IEEE 2413-2019, 2020) defines IoT as "a system of entities (including cyber-physical devices, information resources, and people) that exchange information and interact with the physical world by sensing, processing information, and actuating."

No definition for IIoT was found neither from IEEE IoT, nor from IEEE SA. Nonetheless, (IEEE 2413-2019, 2020) describes IoT domains as being: "Abstract IoT Domain", "Smart Manufacturing (also known as IIoT)", "Smart Grids", "Smart Building", "Intelligent Transportation", "Smart Cities" and "Healthcare". We therefore can establish that IIoT is only perceived as a sub-domain of IoT by IEEE SA.

1.2.1.1.3 By ISO/IEC 20924, 30141 and 30166

"Information technology — Internet of Things (IoT) — Vocabulary" (ISO/IEC 20924, 2018) defines IoT as an "infrastructure of interconnected entities, people, systems and information resources together with services, which processes and reacts to information from the physical world

⁴<https://iot.ieee.org/definition.html>, last accessed April 9, 2021

and the virtual world”. The definition remains the same in the (ISO/IEC 20924, 2021) updated version. This standard does not mention IIoT at all.

“Internet of things (IoT) – Industrial IoT” (ISO/IEC TR 30166, 2020) is a technical review dedicated to Industrial IoT. Its definition for IoT refers to the above one and its definition for IIoT is:

"IIoT is a new industrial ecosystem of service driven built based on the network interconnection, data interoperability and system interoperability of industrial resources, to realize the flexible configuration of the manufacturing materials, the ondemand execution of the manufacturing process, the rational optimization of the manufacturing process and the rapid adaptation of the manufacturing environment, and to achieve the efficient utilization of the resources."

Moreover, it is interesting to point out that

“In addition, this document has expanded this view by seeing IIoT as a subset of IoT as defined in ISO/IEC 30141”

This therefore clearly positions the relationship between the two. It is also to be noted that, surprisingly, the definition arrives quite late in the document (page 26) and after the “Overview” and “Analysis consideration on IIoT landscape of systems” sections. However, from the beginning of the introduction, “The IIoT is an identified vertical of the IoT” clearly sets the stage for an exceptionally subtle difference between the two. Also, “IIoT can be defined upon the IoT reference architecture (ISO/IEC 30141)”. By encountering the term without it being clearly defined before its first utilisation, the reader is kept in the fog until multiples pages later and someone only going for the document’s introduction would have missed this necessary elicitation of the relationship between IoT and IIoT.

(ISO/IEC 30141, 2018) describes a reference architecture for IoT. The reference model (cf. Figure 1-2 below) breaks down the IoT system into various subsystems. At no point does this document mention IIoT. From this as well as the reference model below we can conclude that the ISO/IEC 30141 sees no technical difference between IoT and IIoT (at least from a conceptual point of view).

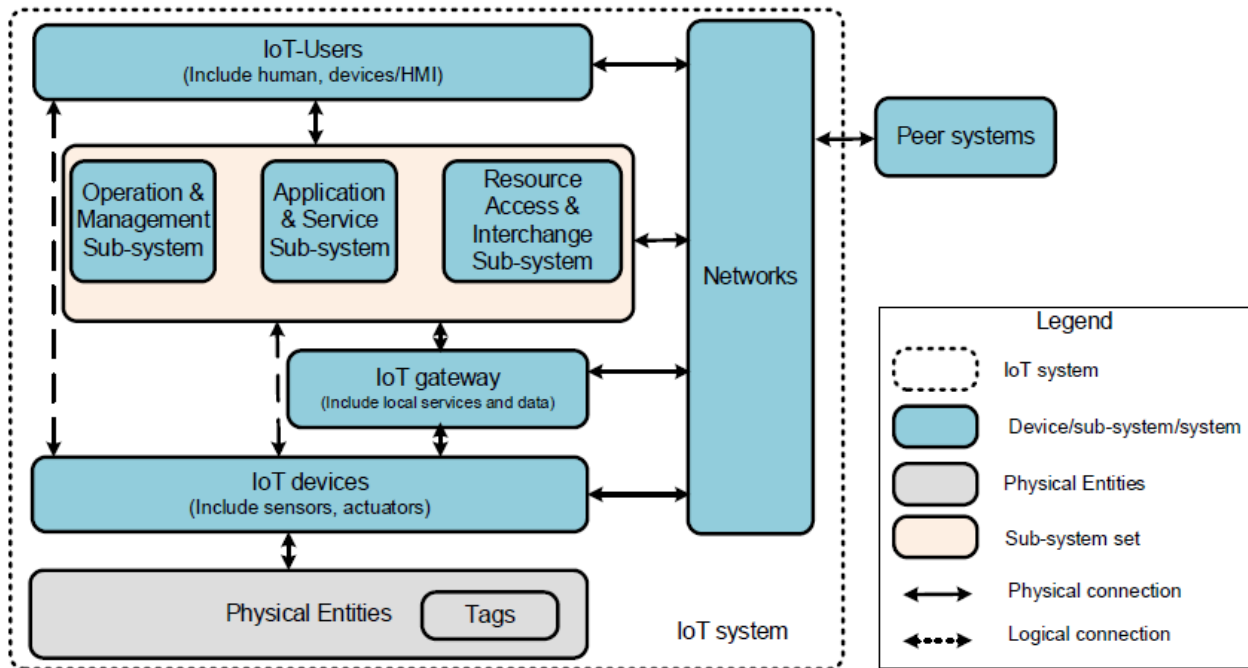

Figure 1-2. “Entity-based IoT Reference Model” from (ISO/IEC 30141:2018, 2018)

Overall and throughout the three mentioned standards, ISO/IEC either does not mention IIoT or clearly defines it as the use of IoT for industrial use-cases without giving in any elements of architectural or conceptual differentiation between both.

1.2.1.1.4 Consolidation of standardisation bodies' positioning

Table of definitions in the Appendix provides an overview of all standardisation bodies' definitions.

Consolidation of standardisation bodies' positioning will be done in three steps. First, we will tackle the difference between IoT and IIoT, then proposed a consolidated IoT definition before finally discussing the IIoT definition.

ITU, IEEE and ISO/IEC provide a similar, if not indistinguishable, difference between IoT and IIoT in their definitions. Indeed, all definitions can be summarized as IIoT is based on IoT and tackles industrial use-cases.

The definitions given for IoT differ in the subtleties of their wordings. ITU does not mention the sensing/actuator layer in its definition – only mentioning “interconnecting things” – whereas ISO/IEC mentions “processes and reacts to information” and IEEE is even more detailed: “sensing, processing information, and actuating.” All three definitions mention “interconnection” and either

“infrastructure” or “system of entities” as common underlying concepts of the definition. “People” are mentioned by IEEE and ISO/IEC as part of the interconnection artefact whereas ITU, probably because of the seniority, mentions “the information society.” Moreover, “services” are mentioned by ITU and ISO/IEC but not by IEEE. IEEE only refers to the physical world whereas the other two refer to the physical as well as the virtual world. All these subtleties do not question a definition or the other but create a fuzziness perception. We sum up the addressed concepts by these definitions in Table 1 before attempting a merged definition to group the most relevant items.

Concepts	(ITU-T Y.4000/Y.2060, 2012)	(IEEE 2413-2019, 2020)	(ISO/IEC 20924, 2018 & 2021)
Interconnection	Yes	-	Yes
People	“The information society”	Yes	Yes
Physical/Virtual	Physical & Virtual	Physical	Physical & Virtual
Services	Yes	-	Yes
Sensing/actuator layer	Interconnecting things	Sensing, processing information, and actuating	processes and reacts to information

Table 1. IoT definition of normative bodies in regard of features addressed

From Table 1, we notice that all but one concept are addressed by ISO/IEC. Therefore, our proposal is to amend the ISO/IEC definition by adding the missing element:

Internet of things is an infrastructure of interconnected entities, people, systems, and information resources together with services, which exchanges information between physical and virtual world by sensing, processing information and actuating

Regarding the IIoT concept, IEEE does not mention it, ITU has a simple definition and therefore only ISO/IEC's one could be considered for scrutiny. Standard definitions are the accomplishment of a concertation and a global consensus, in this case IIoT's one proves to be limited. However, scientific literature is often the birthplace of (rational) controversies, and we wait to investigate academia in next subsection to find out.

1.2.1.2 In the scientific literature

Li et al. (2015) do an extensive definition review for IoT which deceptively ends by concluding that "Depending on various technologies for the implementation, the definition of the IoT varies." In our context however, this is hardly acceptable as a term should have a clear and sound definition in each context to avoid confusion. IoT research in industrial context is said to have started in 2014 (Liu et al., 2017). Moreover, in their review of IoT literature, 7 articles are issues from "IEEE Transactions on Industrial Informatics" but, despite the journal's title including "Industrial", none are reflected upon with the term "Industrial IoT". Liu et al. (2017) argues that (Xu et al., 2014) is a review about "industrial IoT" whereas they did a review about "Internet of things in Industry". Also, Xu et al. (2014) never mention "IIoT" or "Industrial IoT" by itself but always as "industrial IoT applications" and the five outlined research trends do not raise the topic of IIoT. These elements suggest that IIoT has originally no existence by itself but only that it is a domain of application of IoT. Ng et al. (2018) do "A semantic similarity analysis of Internet of Things" but a no point in the article is industrial IoT or IIoT mentioned, only industrial applications of IoT.

Regarding IIoT proposed definition, IIoT is defined by Boyes et al. (2018) as:

"A system comprising networked smart objects, cyber-physical assets, associated generic information technologies and optional cloud or edge computing platforms, which enable real-time, intelligent, and autonomous access, collection, analysis, communications, and exchange of process, product and/or service information, within the industrial environment, so as to optimize overall production value. This value may include improving product or service delivery, boosting productivity, reducing labour costs, reducing energy consumption, and reducing the build-to-order cycle."

This definition is therefore built into two phases with the first one being what could have been commonly defined as IoT and a second phase which narrows information to that of a “process, product and/or service” and then focuses on the created added value. One can notice IIoT is therefore no more and no less than IoT applied to an Industrial context without any fundamental difference in its building blocks. Overall, Boyes et al. (2018) are heavily critical of all existing literature definitions of IIoT stating that they are too simple or “uninformatively circular”. Simple definitions include that of Aberle (2015): “The Industrial Internet of Things (IIoT) is the use of Internet of Things (IoT) technologies in manufacturing” and the World Economic Forum (2015): “Industrial Internet: A short-hand for the industrial applications of IoT, also known as the Industrial Internet of Things, or IIoT”. Such pinpointing by Boyes et al. (2018) to the current (mis)use of the IIoT definition raises legitimate questioning over the actual existence of a different concept from IoT in literature. Moreover, Boyes et al. (2018) do a “review of existing IoT taxonomies” and provides an analysis framework for IIoT based on IoT technology. An example of recent misuse and absence of definition can be found in (Pivoto et al., 2021). Indeed, IIoT is mentioned there many times but never defined and put as an equivalent term to “Internet of Things and Services in the factory environment.”

Differently, Russell et al. (2018) argue that IIoT is IoT “in mission-critical industrial facilities” and Schneider (2016) differentiates IIoT from “consumer IoT” in the sense that it has more security, better reliability, a lower response time than consumer IoT. In this regard, IIoT is not seen as an application of IoT to industry but like IoT which has been made more robust to meet certain needs regardless of the application domain, may it be smart buildings or healthcare.

From the point of view of academic literature, IIoT therefore should not have been called so in many cases but industrial IoT application and despite Boyes et al. (2018) proposing a definition, it remains heavily built upon IoT and the article points out flaws in many people’s perception of IIoT.

The next two sections outline the divide between IIoT as the use-case perspective and IoT as the global research position of this thesis. Indeed, its context is that of the manufacturing industry but could be expanded to the other IoT application domains such as smart health or smart farming.

1.2.1.3 IIoT as the use-case perspective

None of the above IoT definitions encompass a use-case point of view. Given the inputs of standards bodies and the academia perspective, it shall therefore be considered for the rest of this thesis that IIoT embraces a use-case point of view – such as for other IoT Applications domains. Based on the previous references, we therefore define IIoT as:

Industrial Internet of Things is the use-case point of view resulting of the
application of Internet of Things to the Industrial sector.

1.2.2 IoT as the global research position

Through this section, one may notice that the difference in definitions can be narrowed down to IoT addressing the technical items and IIoT as encompassment of the Industrial applications and use-cases. Moreover, part of the literature tends to imply that IIoT systems are necessarily bigger than IoT ones whereas there is no evidence to this regard. Also, as the technological building blocks are identical between IoT and IIoT and, in majority, we shall only address these, it would seem more sensible to use only IoT. At last, many an academe or practitioner continue to feel the confusion as they use the word IIoT when talking about the technology (which should/could be IoT) or use the word IoT when talking about some use-cases in an industrial context (which should/could therefore be IIoT).

Therefore, throughout this thesis, we shall consider IoT with a broader scope in mind and ranging from the simplest consumer IoT to the big Industrial IoT systems without neglecting the other potential application fields. As outlined previously, the proposed definition of IoT - reposing on (ISO/IEC 20924, 2018 & 2021) with the underlined addition from the author based on (IEEE 2413-2019, 2020) - is and remains as follows:

Internet of things is an infrastructure of interconnected entities, people,
systems, and information resources together with services, which exchanges
information between physical and virtual world by sensing, processing
information and actuating

1.2.2.1 Other terminologies: Internet of Production (IoP), Internet of Everything (IoE)

Terminologies such as “Internet of Production” (IoP) or “Internet of Everything” (IoE) have been pushed by vendors (e.g., CISCO for IoE) but these have only found a limited to no existence in academic literature and shall therefore not be considered. Also, Miraz et al. (2015) say that “Qualcomm CEO, Steve Mollenkopf, stated in 2014 that the IoT and IoE were “the same thing””, once more underpinning the fact that further terminology is deemed irrelevant.

On a sidenote, in French, I tend to argue against the two existing translations of the expression “internet of things” as none of them succeed in outlining the major characteristics of IoT. Indeed, “*Internet des objets (IdO)*”, internet of objects or “*Objets connectés*,” connected objects both use the word “object” which is nowhere near as broad as the term “things” is. Moreover, “connected objects” terminology tends to hide the infrastructure part of IoT therefore leading to an extremely limited comprehension of the global IoT scope & stakes. As a result, French speakers tends to use more the English term IoT.

1.3 Problem statement

Whatever the research question might be, it is always interesting or even necessary to understand in what academic context the author has evolved to phrase such a question and how he or she aims to tackle it. The PhD work involved in this thesis was carried out by the author through a CIFRE contract⁵ as he was employed to work on these matters by Inetum (www.inetum.com) – known as Gfi Informatique prior to September 1st, 2021 – and a PhD student at the Université de technologie de Compiègne.

⁵In France, the CIFRE system (Convention Industrielle de Formation par la Recherche) is a specific means of financing a thesis. It allows a company established in France to benefit from financial assistance to recruit a young doctoral researcher whose research work, supervised by a public research laboratory, leads to the defense of a thesis. It is the ANRT (National Association for Research and Technology) which validates the CIFRE system after the signature of three contracts: an employment contract (between the doctoral student and the company), a thesis contract (between the doctoral student and the research laboratory), and a collaboration contract (between the laboratory and the company).

In this section, first the industrial context and second the scientific one will be detailed before going on to phrasing out the research question of this thesis.

1.3.1 Industrial context

As a benchmark European player in value-added Information Technology (IT) services and software, Inetum company occupies a strategic position that allows it to differentiate itself from world-class operators and niche players. The Inetum group values innovation as an accelerator of digital transformation. Within the consulting branch, the PLM business unit (BU) wished to broaden its scope of expertise in terms of product lifecycle management, especially regarding Industry 4.0 and IoT. The initiative is part of a group approach that aims to address the challenges of tomorrow by integrating major contemporary innovations. In this context, IoT is identified as an important axis of innovation to serve the management of the product life cycle. With this thesis, the Industry 4.0 BU (previously PLM BU) of Inetum aims to expand its vision of connected product management (identify new uses, identify sector transformations, transform product management methods, optimally equip manufacturers). In doing so, Inetum's Industry 4.0 BU would then be able to demonstrate its capabilities and support major manufacturers in their digital transformation.

1.3.2 Scientific context

In the current context of developments in the Factories of the Future (also known as Industry 4.0, Industry 5.0, or Smart Manufacturing), one of the major challenges is to ensure the digital thread of industrial data (Eynard & Bosch-Mauchand, 2015). The integration of corporate or enterprise information systems (PLM, MPM, APS, ERP, MES, CMMS)⁶ has mobilized research efforts over the past 25 years for better interoperability of solutions (El Kadiri et al., 2016). It is now necessary to be able to take into account new sources of information from Internet of Things which are becoming widespread. These IoT data sources provide additional information concerning the real and operational state of a manufacturing machine or industrial equipment, feedback on the maturity

⁶ Product Lifecycle Management (PLM), Manufacturing Process Management (MPM), Advanced Planning System (APS), Enterprise-resource Planning (ERP), Manufacturing Execution System (MES), Computerized Maintenance Management System (CMMS)

of the life cycle of the product or process concerned. This data collection and subsequent data consolidation will improve the design, development, uses and operation of products by the customer or asset management or maintenance stakeholders (well known in Product-Service System approaches).

1.3.3 Phrasing the problem statement

IoT and PLM each have very vast associated fields of research, ranging from corporate strategy to new product introduction as well as purchase strategies and marketing. However, throughout this thesis, we shall focus of the field created by the intersection of PLM and IoT. Given the narrowness of the field, we shall extend our considerations to PLM and IoT domains as well as enterprise architecture and enterprise information systems alike.

Therefore, the problem statement can be outlined as:

[How to ensure a digital thread between PLM and IoT eco-systems?](#)

However, this question uses *digital thread* which is a common concept within the PLM practitioners' community but hardly defined by academia. Digital Thread is often defined as the data and information flow between a product and its Digital Twin, where the Digital Twin is a digital representation of all things regarding the product, thus making it an - unhelpful- circular definition. Hedberg et al. (2016) argue that "Those leading the efforts to bring the digital revolution to the manufacturing of complex products coined the term digital thread to convey the data flows between engineering, manufacturing, business processes, and across supply chains". Moreover, *connected objects* are the last kilometre of IoT and therefore one needs to assess the digital thread until these. We therefore will redefine the problem statement as:

How to link product lifecycle management information, especially engineering information, and data from connected objects, whatever they are, in a discrete manufacturing⁷ industry context?

This can be taken as a bijective relationship between PLM and IoT, and therefore broken down into what is necessary from IoT for PLM and what is necessary from PLM for IoT.

Although the answer provided to this question might be also relevant for other fields and industry verticals, we shall indeed limit the boundary of application of such research work to the discrete manufacturing industry as it is most known to the author and the verification case study demonstrates the proposal in such a context. Chapter 6 “Discussion” will, of course, discuss the applicability of such a proposition to other industrial verticals and pave the way for necessary adaptations, if any.

⁷ *Discrete Manufacturing includes makers of consumer electronics, computer and accessories, appliances, and other household items, as well as "big ticket" consumer and commercial goods like cars and aeroplanes. Discrete Manufacturing companies make physical products that go directly to businesses and consumers, and assemblies that are used by other manufacturers.* From https://en.wikipedia.org/wiki/Discrete_manufacturing, last accessed September 25, 2022

1.4 Thesis structure

This Thesis' introduction outlined the global stakes at work demonstrating the ecological necessity and the economic potential associated to ensuring a digital thread between PLM and IoT. It also positioned regarding the terminology debate between IoT and IIoT and then exposed the problem statement.

Chapter 2 "State of the art" will outline the lack of existing methodology and sketch the latest advances in both PLM and IoT domains. We will then run by existing PLM-IoT joint literature. After that, we will explore the notion of interoperability to set the scene. Also, the Digital twin combined with Cyber-Physical System concept will be addressed. Finally, we will formulate the scientific research question in light of the state of the art.

Chapter 3 "Proposition" will position four key existing concepts in respect to the proposed framework before going on to detail the three novel components of the proposition: (a) Function-enabled PLM, (b) Problem report as a medium & (c) Enrichment of 'as to be' baseline. Finally, we will define the verification & validation criteria for the proposition.

Chapter 4 "Industrial readiness of Methodological Framework" will continue with a technical feasibility implementation of the proposition based on industry-ready solution: the Windchill PLM software and ThingWorx IoT platform. Verification will close the chapter.

Chapter 5 "Validation on a case study" will explore the real-life use-case based on REBO smart bottle to demonstrate the proposition's added value. Demonstrating will also be done on fictional scenarios to validate the proposition as much as possible.

Chapter 6 "Discussion" will tackle the reproducibility of the work as well as the adaptability of the method to other industrial contexts as well as regarding product complexity and support complexity. Finally, we will lean on to the Digital Twin to understand how this proposition could contribute to its adoption.

Chapter 7 "Conclusion (and future work)" will wrap up the thesis by summing up the findings and its limits as well as reflecting on the future work this could enable.

CHAPTER 2 STATE OF THE ART

This state-of-the-art chapter shall demonstrate the gaps in the existing literature. After having positioned our work as holistic and systemic from a philosophical point of view, we shall first demonstrate the lack of an existing suitable modelling or architecture framework to answer our research question by exploring Enterprise, IT management & Industry 4.0 architectures. Next, we will dive into PLM from an academia perspective and from a practitioner perspective. We then will outline work conducted on IoT platforms. Having demonstrated a lack of existing current proposition concerning the establishment of a digital thread in both domains, we will synthesize author's published works about PLM and IoT joint literature. After, as we are trying to connect two different domains, we outline the necessary in matters of interoperability. Finally, we will raise the Digital Twin terminology as our work might be a contribution to the Digital Twin building and definition.

2.1 Lack of an existing suitable modelling

Tackling a topic such as digital thread between PLM and IoT requires to position the work regarding a philosophical position concerning rooting the understanding and intelligibility of a system. Two classic visions oppose themselves: a holistic one coming from Aristotle and an analytic one coming from Descartes.

“The whole is greater than the sum of its parts” is a misquote of the original Aristotle's *Metaphysics*:

“In all things which have a **plurality of parts, and which are not a total aggregate but a whole of some sort distinct from the parts**, there is some cause; inasmuch as even in bodies sometimes contact is the cause of their unity, and sometimes viscosity or some other such quality.” (Aristotle, 980BC.)

Here, Aristotle considers the entire system to be more than the addition of the various parts it is composed of, this is often referred to as holism. An opposite vision is that of Descartes who is a partisan of a more analytical procedure to tackle a system:

“(1) Accept nothing as true that is not self-evident, (2) divide problems into their simplest parts, (3) solve problems by proceeding from simple to complex, and

(4) recheck the reasoning. These rules are a direct application of mathematical procedures. In addition, Descartes insisted that all key concepts and the limits of each problem must be clearly defined.” (Watson, 2021)

However, in domains as wide as PLM and IoT, defining clearly all the key concepts as well as the limits of each problem seems challenging if not bluntly impossible. Moreover, a problem’s complexity comes from its size and chopping it down will not necessarily help. Finally, as mentioned for IoT and as will be mentioned later for PLM, both PLM and IoT rely on holistic definitions therefore justifying that the problem can not necessarily be tackled in an analytical way. Therefore, we shall define our holistic approach in view of works from this way of thinking.

Eriksson (1997) synthetizes the works of Jean-Louis Le Moigne. He does a comparison of the analytical and the systemic method reproduced in Table 2 below. Moreover, Table 3 below gives the definition of the principles of Le Moigne’s systemic method.

<u>The discussion of the method:</u>	<u>Descartes’ analytical method</u>	<u>Le Moigne’s systemic method</u>
1 st precept of:	evidence	pertinence
2 nd precept of:	reduction	interaction
3 rd precept of:	causality	teleology
4 th precept of:	exhaustivity	aggregation

Table 2. Juxtaposition of Descartes’s analytical method and Le Moigne’s systemic method, according to (Eriksson, 1997)

<u>Le Moigne's systemic method</u>	<u>Definition quoted by (Eriksson, 1997)</u>
pertinence	Agree that all objects that we consider define themselves in relation to implicit or explicit intentions of the modeller and to never forbid ourselves from doubting this definition, if in modifying our intentions the perception we have of these objects also changes.
interaction	Always consider the object to be known by our intelligence as an integral and active part of a greater whole. Perceive it first globally, in functional relation with its environment without worrying about establishing a faithful image of its internal structure, where existence and uniqueness are never considered given.
teleology	[...] interpret the object through its behaviour not through itself, without first searching to explain its behaviour through some law implied in an eventual structure. Understand on the other hand its behaviour and the recourses it commands in relation to projects that the modeller freely attributes to the object. Consider the identification of these hypothetical projects a rational act of intelligence and agree that their demonstration will be rarely possible.
aggregation	Agree that all representation is partisan, not through the forgetfulness of the modeller, but deliberately. In consequence, research recipes capable of guiding the selection of aggregates considered pertinent and exclude the illusionary objectivity of an exhaustive enumeration of elements to consider.

Table 3. Le Moigne's systemic method principles and their definition, according to (Eriksson, 1997)

Moreover, Le Moigne (1990) suggests that a complicated system can be simplified to build explicability whereas a complex system needs to be modelled to construct one's comprehension of it. We therefore need models to see and comprehend how our components can fit in the picture. Finally, the holistic approach is also comforted by the European Commission as its recommendation 20 of the European Interoperability Framework (European Commission. DGI., 2017) is: "Ensure holistic governance of interoperability activities across administrative levels and sectors."

Overall, the constructivist movement to which Le Moigne belongs postulates that knowledge of the world is a human construction and that therefore our knowledge of an artefact is the result of both our mental projection of the artefact and the artefact itself. Therefore, models of a system, an

enterprise for instance, directly contribute to shape the way the system is (that only being an explanation for what it is, if in an analytical perspective).

2.1.1.1 Existing architectures and models

Sometimes called architectures, sometimes called models and even architecture models or frameworks, they all aim to allow a better understanding of how things work in a systemic approach as depicted before. PLM and IoT are two core components of enterprise & IT systems. (Chen et al., 2008) dedicates a sub section to “Enterprise conceptual vs. IT architecture” and puts forward the fact that both these research communities are attempting to develop enterprise architecture from two different perspectives. For that reason, we will tackle enterprise architectures and IT management architectures subsequently before tackling Industry 4.0 architectures, a new set of standards that have emerged in recent years to tackle the integration of recent technologies. This will begin our attempt to find how to ensure a digital thread between PLM and IoT.

2.1.1.2 Enterprise architecture

The standard “Enterprise integration — Framework for enterprise modelling” (ISO 15704:2019, 2019) does not define, by itself, enterprise architecture, but does define separately enterprise and architecture. However, it defines “enterprise model” as a “representation of an enterprise as well as entities within an enterprise, their interrelationships, their decomposition and detailing to the extent necessary to convey what the enterprise intends to accomplish and how it operates.” We shall outline here only a few of the existing enterprise architectures frameworks. For an exclusive overview of enterprise modelling, please refer to (Vernadat, 2020) for an extensive historical approach and (Chen et al., 2008) for challenges and a critical view towards the lack of industrial involvement in the Enterprise Model development and hence lack of use. As put by Chen et al. (2008), “enterprise architectures [...] reflect the background/competencies of their developers and the purpose for which they were elaborated: for example, CIMOSA for computer integrated manufacturing, GRAI for production management and decision-making, PERA for system engineering, Zachman for information systems and DoDAF for military operations management and coordination”. Given this, as well as the proximity of these backgrounds with PLM and IoT, we shall dive into GRAI and PERA before moving on to GERAM, which aims to synthesize these enterprise architecture framework as well as others into one unique one.

2.1.1.2.1 Zachman Framework

The Zachman Framework, originated by and named after John Zachman, started in the 1980's. The original framework has been extended multiple times and aimed at creating a comprehensive description of enterprises through the use of a two-dimensional matrix representing in the rows a given perspective and in columns a fundamental question (often summed-up with 5W1H⁸) as shown in

Figure 2-1 below. It often is referred to as the base for other enterprise architecture frameworks. (Noran, 2003) points out that the lifecycle perspective is not embraced and that it represents the perspectives of the human roles rather than describing life cycle phases as other frameworks do.

	DATA <i>What</i>	FUNCTION <i>How</i>	NETWORK <i>Where</i>	PEOPLE <i>Who</i>	TIME <i>When</i>	MOTIVATION <i>Why</i>
Objective/Scope (contextual) <i>Role: Planner</i>	List of things important in the business	List of Business Processes	List of Business Locations	List of important Organizations	List of Events	List of Business Goal & Strategies
Enterprise Model (conceptual) <i>Role: Owner</i>	Conceptual Data/ Object Model	Business Process Model	Business Logistics System	Work Flow Model	Master Schedule	Business Plan
System Model (logical) <i>Role: Designer</i>	Logical Data Model	System Architecture Model	Distributed Systems Architecture	Human Interface Architecture	Processing Structure	Business Rule Model
Technology Model (physical) <i>Role: Builder</i>	Physical Data/Class Model	Technology Design Model	Technology Architecture	Presentation Architecture	Control Structure	Rule Design
Detailed Representation (out of context) <i>Role: Programmer</i>	Data Definition	Program	Network Architecture	Security Architecture	Timing Definition	Rule Speculation
Functioning Enterprise <i>Role: User</i>	Usable Data	Working Function	Usable Network	Functioning Organization	Implemented Schedule	Working Strategy

Figure 2-1. "Zachman Framework" from Wikimedia⁹

⁸ Who, What, When, Where, Why, How

⁹ al, M. D. D. based on earlier work of P. et. (2008). *Zachman Framework basics*. self-made, combination of File:Zachman Framework Basics.jpg and File:Zachman Framework.jpg.
https://commons.wikimedia.org/wiki/File:Zachman_Framework_Detailed.jpg

2.1.1.2.2 *GRAI & GIM*

GRAI stands for Graphs with Results and Actions Inter-related. Developed in France by (Pun, 1979), these graphs were integrated in the GRAI Grid defined by Guy Doumeingts in his Habilitation Thesis in 1984 (Doumeingts, 1984). It was further extended as GIM (GRAI Integrated Methodology) then popularized as GRAI Methodology (Chen et al., 1997).

(Vernadat, 2020) says that “Originally, the aim [of GRAI] was to analyse the decision system of flexible manufacturing and CIM systems from a production management perspective. The approach consisted in identifying ‘decision centres’ at the various decision levels of an enterprise and analysing their interactions (in terms of information links and decision frames) and their behaviour (in terms of transformation and decision activities).”

GRAI is “based on several Ph.D. research works” (Chen et al., 1997) and was extended by multiple researchers, such as Benoit Eynard who, in his PhD Thesis (Eynard, 1999), extends it by jointly and simultaneously modelling the product and the design activities.

As an anecdote: from a commercial point of view, the start-up GraiSoft was founded in 1998 to provide consulting services & related software development. It ended up being brought by Adeliior, a former subsidiary of Inetum (ex-Gfi)¹⁰. Inetum being the same company where the author was hired to conduct these research works!

2.1.1.2.3 *PERA*

PERA stands for Purdue Enterprise Reference Architecture and was developed in the United States in the 1990s. PERA is one of the reference models for enterprise architecture.

Figure 2-2 below, extracted from (Williams, 1994), outlines the main issue we see with PERA. Indeed, PERA separates the information architecture & manufacturing architecture. These two are linked by the human and organizational architecture. However, evolution of enterprise ICT systems

¹⁰ "GraiSoft, for example, born in Bordeaux, for the edition of BPM (Business Process Management) modelling software tools, since absorbed by Adeliior, a subsidiary of GFI" from <https://www.lemondeinformatique.fr/actualites/lire-la-recherche-sur-l-interoperabilite-regroupe-industriels-et-labos-autour-d-un-pole-occitan-21711.html>, last accessed June 5, 2022

have erased the clear border that once existed between the information technology and the shop floor. For instance, the Manufacturing Execution Systems (MES) are now direct information within the manufacturing architecture. To this regard, and as it has not been recently maintained, PERA does not seem fit to build the digital thread between PLM and IoT.

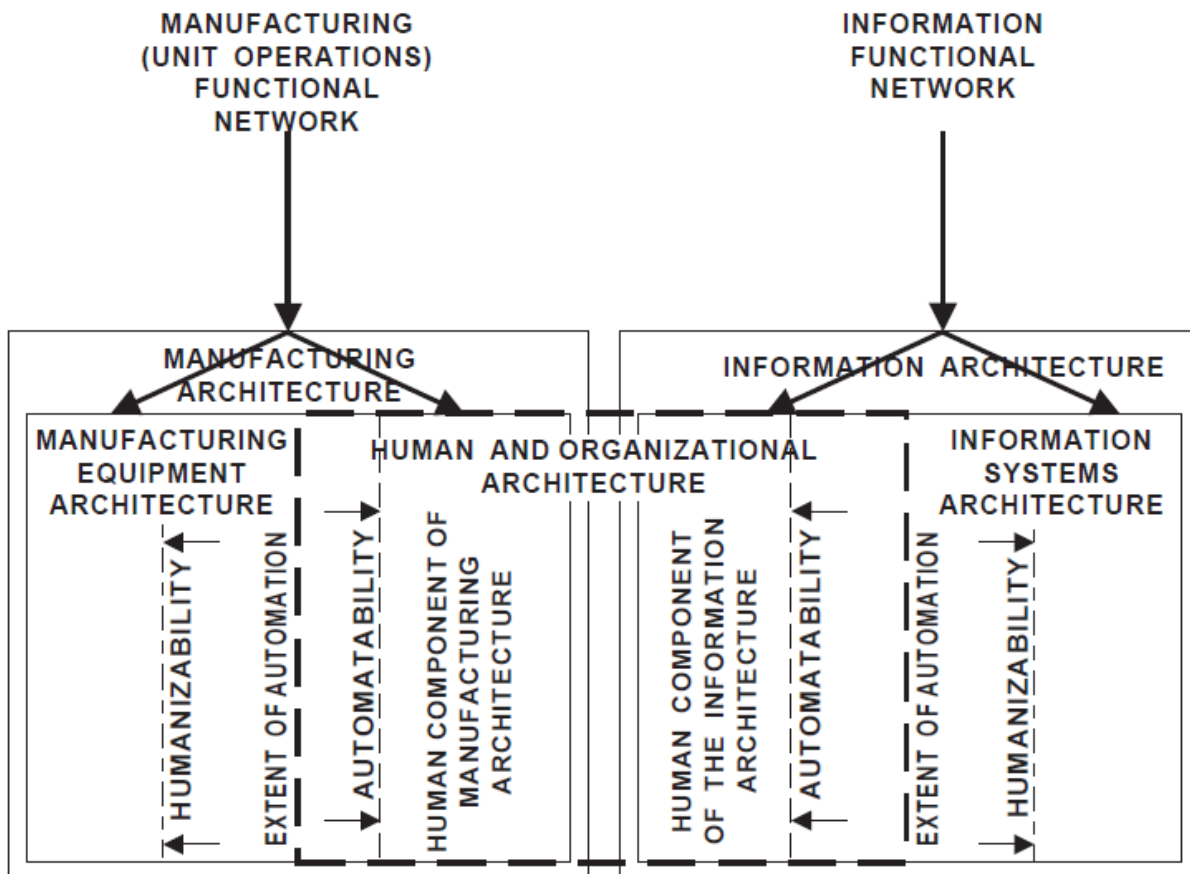

Figure 2-2. “Relations of the Automatability, Humanizability and Extent of Automation lines in defining the human and organizational architecture,” from (Williams, 1994)

2.1.1.2.4 CIMOSA

CIMOSA stands for Computer Integrated Manufacturing (CIM) Open System Architecture. It was developed in the early 1990’s as part of a European project. The aim was to “to elaborate an open system architecture for CIM and to define a set of concepts and rules to facilitate the building of future CIM systems” (CIMOSA, 2022). Vernadat (1990) presents the Function and Information views designed to model CIM system at requirement definition, design specification and

implementation description levels. Resource and organization views were then developed. Unfortunately, due to retirements, CIMOSA association was discontinued in 2010 (CIMOSA News, 2022).

2.1.1.2.5 GERAM

GERAM stands for Generalised Enterprise Reference Architecture and Methodology. It is a generalized enterprise architecture framework. “Generalised” means that all the previous frameworks were integrated in to build this: “GERAM is meant to unify existing architectures rather than intending to replace them” (Bernus & Nemes, 1996). This implies that the pre-existing architectures could still live besides GERAM. For instance, (Chen et al., 1997) maps GRAI onto GERAM to be able to easily transition from one to the other. As an extended work, Noran (2003) does the mapping of multiple architecture frameworks, including previously cited GRAI and PERA, onto GERAM. GERAM was the foundation for the creation of its associated standard: ISO 15704:2000.

“Nevertheless, the impact of GERAM at the industry level is not as significant as expected. One of the reasons is on the one hand the lack of industry involvement in the study and, on the other hand, the conceptual characteristics of the study” (Chen et al., 2008). Since then, ISO 15704:2000 was superseded by its 2019 version (ISO 15704:2019, 2019), this updated version as well as the activity generated around it might bring changes to the landscape. However, to date, no noticeable change could be observed. Overall, the response to the research question might be remapped onto GERAM although the need to stick to it does not stand out from an industry point of view.

2.1.1.2.6 Inadequacy of enterprise architecture

Enterprise architecture models were first developed with the aim of putting in writing the various processes and artefacts related to a company. At no point was it built to introduce new systems or processes that would enhance the current situation. Nevertheless, those enterprise architecture models could be further amended to include the link between PLM and IoT. Indeed Vernadat (2020) considers that future work needs to be carried out on “Impacts of Smart Manufacturing,

Industry 4.0, and Cloud Manufacturing on EM¹¹: [...] EM researchers must figure out what this means in terms of EM constructs to be added or modified in EMLs and in international standards.” For the time being, we shall look at IT management architectures to see if these could provide such details.

2.1.1.3 IT management architectures

IT management architectures, sometimes referred to as Information systems governance frameworks, enable company’s IT departments to organize themselves to define their offering both to internal and external stakeholders. Given that our research question revolves around information and data, both who are key to these departments, and given the fact that the PLM systems are most often managed by IT on behalf of engineering, IT management architecture sounds like a valid hypothesis. We will first define ITSM as it is often confused with an architecture and then we will explore various architectures (ITIL, CMMI, COBIT, ITU) to see if our research question might be addressed by these.

2.1.1.3.1 ITSM

ITSM stands for Information Technology Service Management. According to Iden & Eikebrokk (2013), “There is no single authorized text that defines ITSM”. It therefore defines it as “an approach to IT operations that is characterized by its emphasis on IT services, customers, service level agreements, and an IT function’s handling of its daily activities through processes”. Therefore, ITSM is not an architecture but instead a conceptual approach to the way enterprise IT services is built and delivered. Some consider it to be standardized by ISO/CEI 20000. It is not a framework, although often confused with ITIL as it is the most popular ITSM framework. Other frameworks include CMMI, COBIT & ITU which will also be presented thereafter.

2.1.1.3.2 ITIL

ITIL stands for Information Technology Infrastructure Library and its latest version v4 was released in 2019. It self-defines as “a framework for service management.” ITIL is the result of

¹¹ Enterprise Modelling

work carried out by the British Public Trade Office (Office of Government Commerce). It is a selection of customer-oriented best practices to ensure effective management, risk control, and quality of IT services. Although originally built for the public sector, it is now widely used within the private sector too. As displayed in Table 4 below, ITIL v4 is built upon 34 practices (previously referred to as processes in v3): 14 general ones, 17 service-oriented ones & 3 technical ones.

General Management practices	Service Management practices	Technical Management practices
Architecture management	Availability management	Deployment management
Continual improvement	Business analysis	Infrastructure and platform management
Information security management	Capacity and performance management	Software development and management
Knowledge management	Change control	
Measurement and reporting	Incident management	
Organizational change management	IT asset management	
Portfolio management	Monitoring and event management	
Project management	Problem management	
Relationship management	Release management	
Risk management	Service catalogue management	
Service financial management	Service configuration management	
Strategy management	Service continuity management	
Supplier management	Service design	
Workforce and talent management	Service level management	
	Service request management	
	Service validation and testing	

Table 4. ITIL v4's 34 practices by type

However, these practices are highly focused on IT and do not address neither the specificities of having a smart product offering, nor the fact of using IoT and PLM altogether. Therefore, ITIL will not allow us to link out-of-the-box PLM and IoT.

2.1.1.3.3 CMMI

CMMI stands for Capability Maturity Model Integration and its latest version v2.0 was released in 2018 (ISACA, 2018). It is a process-oriented assessment model of the ability to achieve IT achievement goals. Based on a repository of good practices in the profession, it is part of a logic of

continuous improvement: (Cusick, 2019) describes the process improvement history leading to CMMI. Overall, CMMI is structured in 25 processes grouped into four areas: process management, project management, engineering, and support. The CMMI model also defines 5 levels of maturity from initial to optimizing. It is built as a framework to measure maturity and put a continuous improvement effort in place but at no point does it go into detail of the various information systems. Therefore, it does not directly address neither PLM nor IoT so it will not be of any direct help to answer our research question.

2.1.1.3.4 COBIT

CoBiT stands for Control Objectives for Information and Related Technologies. It was designed by the ISACA (Information Systems Audit and Control Association), and its latest release was COBIT 2019.

It is a frame of reference as well as a set of tools considered essential to ensure the control and especially the monitoring (audit) of the governance of the information system over time. COBIT is based on a set of good practices collected from IS experts from various sectors (industry and services). COBIT identifies a list of 17 targets for any company out of which the closest one to our research question is the first which is “value for the stakeholders” (ISACA, 2012). This target is then achieved in a variety of ways by the information system’s own objectives. However, the criteria are on a business requirement perspective and do not encompass the technical aspects of it. Therefore, COBIT is of no direct help to tackle our research questions.

On a sidenote, ISACA, which contributed both to CMMI and COBIT as well as ensuring their management, offers a variety of certifications associated to these frameworks but also others. One of these is an “IoT fundamentals certificate¹². Unfortunately, no associated framework or documentation related to this has been released nor announced.

¹² <https://www.isaca.org/credentialing/cet/iot-fundamentals-certificate>, last accessed on June 29, 2022.

2.1.1.3.5 ITU

“Overview of smart manufacturing in the context of the industrial Internet of things” (ITU-T Y.4003, 2018) contains Clause 8 titled “Reference model of smart manufacturing in the context of the IIoT” which it is Clause 8.1 is “Reference model in the product life-cycle view”. Therefore, given the fact that both IoT and PLM are addressed in the title, one might find there the answer to our research question. The core proposal, resumed and illustrated by Figure 2-3 below, is built upon a three-dimensional matrix with an “intelligence”, a “Product lifecycle” and a “system hierarchy axis”. However, at no point is the intersection of these axis clearly defined in terms of content. It is precisely there that the research question is and the gap it intends to close.

Despite not contributing to our proposal, (ITU-T Y.4003, 2018) enables one to better understand the positioning of the research question as an intersection of the different axis.

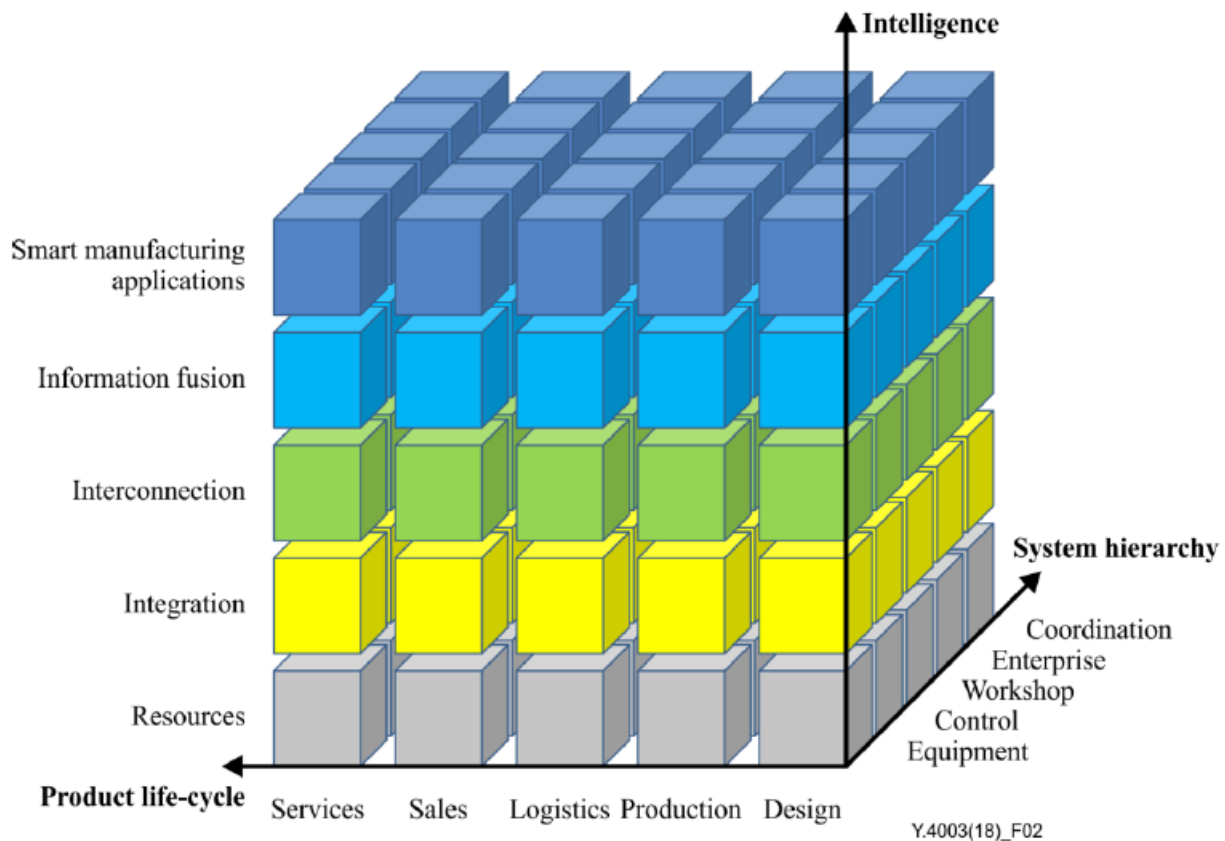

Figure 2-3. “Reference model of smart manufacturing in the context of the industrial IoT in the product life-cycle view”, according to (ITU-T Y.4003, 2018)

2.1.1.3.6 Inadequacy of IT management architectures

The studied IT management architectures, despite resulting from different contexts, all tackle the IT systems themselves without explicitly addressing the link between PLM and IoT from a technical process point of view. We therefore need to look for other potential architectures such as Industry 4.0 ones.

2.1.1.4 Industry 4.0 architectures

In the previous mentioned architecture, the recent rapid growth of IoT has not been encompassed at all yet whereas it is deemed to occupy a predominant place in our life and industries in the decades to come. The main target of Industry 4.0 architectures is to provide a way forward for the use of standards relating to the concept of the "smart factory", subsequently applicable in various companies belonging to different industrial sectors (Cadoret et al., 2021). Indeed, the emerging context fuels the creation of new reference models. We shall therefore look towards IIRA & RAMI as well as 5C to search for the link they might enable between PLM & IoT.

2.1.1.4.1 IIRA

The Industrial Internet Reference Architecture (IIRA) was published in 2015 by the Industrial Internet Consortium Architecture Task Group¹³. It defines functional areas and the technologies and standards for them, from sensors to data analytics and business applications.

The main aim of this architecture is to position new concepts and artefacts. It is aimed at specialists to build a collective understanding but does not provide any element as to how PLM and IoT might or should be connected.

¹³ Industrial Internet Consortium rebranded as the Industry IoT Consortium in August 2021.

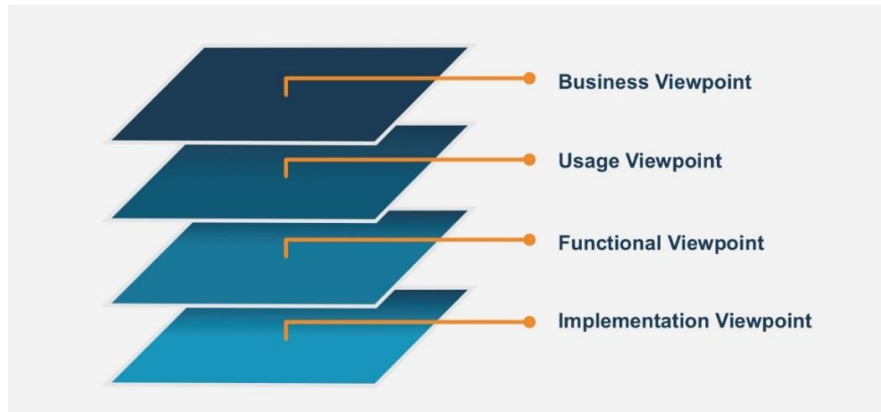

Figure 2-4. “Industrial Internet Architecture Viewpoints”, according to (Industrial Internet Consortium, 2019, p. 1), illustration from IIC¹⁴

2.1.1.4.2 RAMI 4.0

The Reference Architecture Model Industrie 4.0 (RAMI) was created by a community of Industry 4.0 in Germany as a reference model for the lifecycle of a product. The model has three dimensions: layers (from asset to business), hierarchical levels (from product to work-centre to connected world), and the lifecycle value stream. In the third dimension, the lifecycle value stream is separated into two subsequent sections: the lifecycle of the type (as designed) and the lifecycle of the instances (as produced). (Nyffenegger et al., 2018)

¹⁴ <https://hub.iiconsortium.org/iira>, last accessed on September 13, 2022

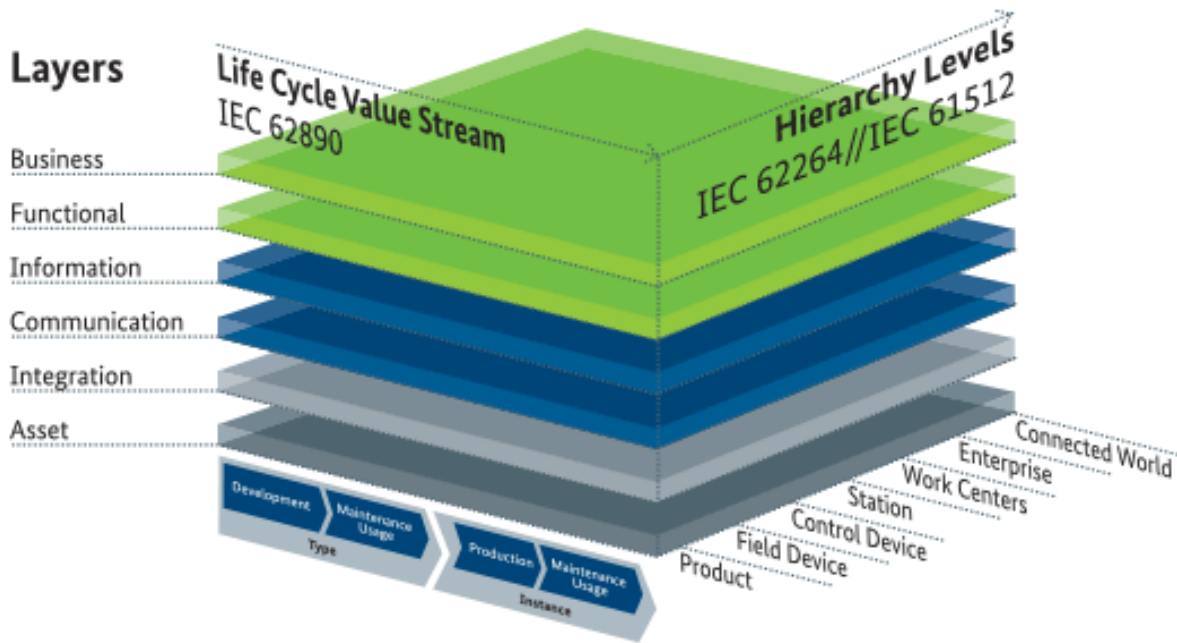

Figure 2-5. “Reference Architectural Model Industrie 4.0 (RAMI 4.0)”

However, and similarly to IIRA, RAMI 4.0 is aimed at positioning items but does not outline how PLM and IoT might be linked.

2.1.1.4.3 5C

5C stands for the 5 levels of its architecture: Configure, Cognition, Cyber, Conversion, Connection (Lee et al., 2015). Figure 2-6 below demonstrates the 5C architecture. (Ahmadi et al., 2017) proposes a Cyber-Physical System (CPS) 5C framework for manufacturing based on standard.

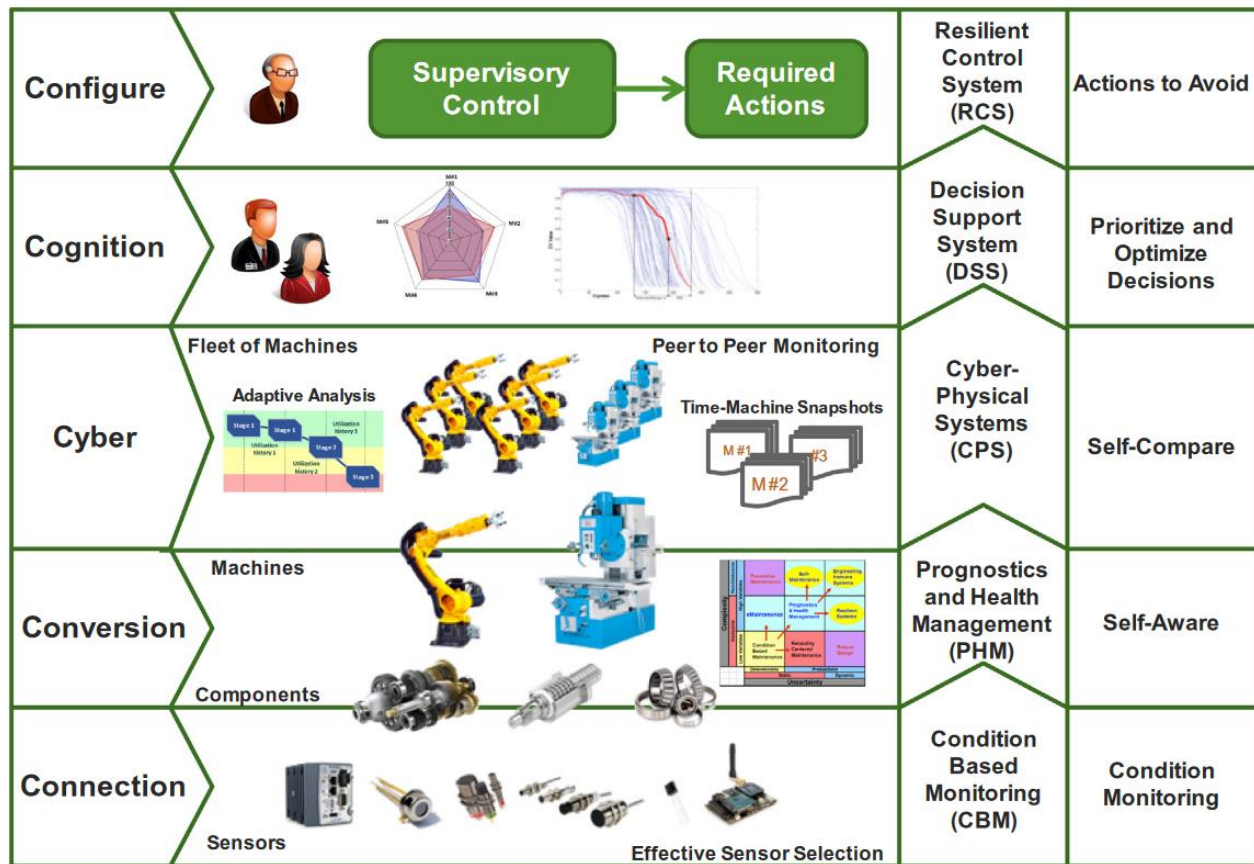

Figure 2-6. “Applications and techniques associated with each level of the 5C architecture.” From (Lee et al., 2015)

Within 5C, IoT could be assimilated to the CPS level and PLM could be considered as one of the components of the Decision Support System (DSS). Unfortunately to date, 5C architecture does not frame how its various components are to be linked together.

2.1.1.4.4 Convergence of the previous models

It is important to note that a similar process to GERAM for the various enterprise architecture models is happening for the Industry 4.0 models. Indeed, all three IIRA, RAMI & 5C aim to achieve a similar target despite different originating points. It is therefore interesting to mention a few initiatives that are hinting at a possibility of convergence.

Firstly, Lin et al. (2017) propose a “Architecture Alignment and Interoperability” between IIRA & RAMI: “The lifecycle process of IIoT system and RAMI 4.0 Life Cycle and Value-Stream will be elaborated in a separate whitepaper to be published jointly by the both organizations.” However,

to this date, no such publication is to be found on the internet: neither on the IIC website page dedicated to collaboration with the German government's initiative Plattform I4.0¹⁵, nor as part of the Plattform I4.0 publication page¹⁶.

Secondly, Pivoto et al. (2021) do an exhaustive literature review of “Cyber-physical systems architectures for industrial internet of things applications in Industry 4.0”. Most notably, it proposes a correlation between the three models which is summed up in Figure 2-7 below.

¹⁵ <https://www.iiconsortium.org/iic-i40-joint-work/>, last accessed on June 30, 2022

¹⁶ https://www.plattform-i40.de/SiteGlobals/IP/Forms/Listen/Downloads/EN/Downloads_Formular.html, last accessed October 7th, 2022

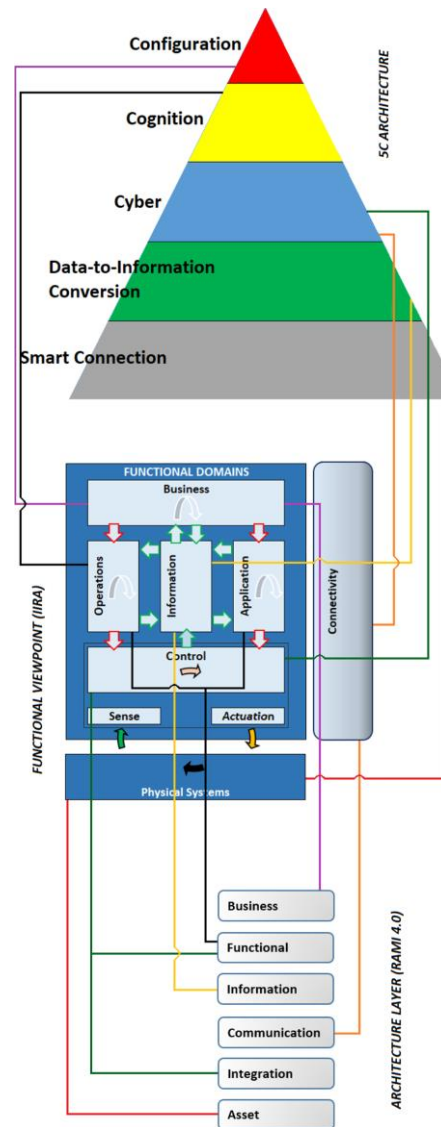

Figure 2-7. “Functional mapping among 5C Architecture, IIRA and RAMI 4.0.”, from (Pivoto et al., 2021)

2.1.1.4.5 Inadequacy of Industry 4.0 architectures

The Industry 4.0 architectures, despite providing some further insights, especially regarding the technologies’ respective positioning, do not provide a clear answer about how IoT and PLM should be linked.

2.1.2 Missing a suitable methodology or architecture

The existing methodologies have been developed throughout the recent decades and are the result of attempting to model the existing organizations or to enable the positioning of recent technologies in a structured manner. However, these do not consider the enterprise information systems in themselves and do not dedicate a perspective to this. Therefore, one is unable to use one of them to answer the research question. In the following sections, we will dive respectively into PLM, then IoT Platforms before discussing the existing literature addressing both.

2.2 PLM and IT PLM

Product lifecycle management has the difficulty of having two coexisting definitions: the first being that of the academia and the second being that of the practitioners (under the influence of the software vendors). That of the academia aims to encompass the whole domain whereas that of the practitioners focuses only on the associated IT system, we therefore will respectively name these PLM and IT PLM or PLM software for sake of clarity.

2.2.1 PLM from academia perspective

2.2.1.1 A historical perspective

The aim here is not to be exhaustive but to give some keys and references to any reader to understand what happened and how the community ended up where it is. Rangan et al. (2005) outlines the evolution of PLM from the “engineering database management” of the 1980’s up to the date of publication (2005) going through what it classifies as the Product Data Management (PDM), design collaboration, enterprise-centricity and scaling up eras. PDM was strongly structured on product data model and workflow for its implementation often specified in UML (Eynard et al., 2004). Kiritsis (2011) propose some insight for the next era and presents PLM as the expansion of the “Product Data Management’s (PDM) scope to provide more product-related information to the extended enterprise.” From a practitioner’s perspective, Meier et al. (2017) look back over the past twenty years of experience in implementation and customization of PLM applications. They argue that the last twenty years of PLM projects has seen an increasing complexity in the PLM systems despite no increase in the complexity of enterprises.

Silventoinen et al. (2011) introduces a parallel in between PLM's history and ERP's one arguing that "Both ERP and PLM are not just information systems but business process approaches." This parallel is resumed in Table 5 below.

		Feature	Aim
First phase	MRP	model the material flow and machine capacities in a computer program	calculate the optimal loading of machines in a workshop to reduce cost
	EDM	organising the storage of CAD-data	reduce engineering cost by saving search time
Second phase	MRPII	the possibility to also vary capacity over time	anticipate seasonal fluctuations in overall demand
	PDM	Also manage the processes of creation and application of product data	reduce the cost of handling and communicating data and to eliminate the cost of errors caused by using wrong versions
Third phase	ERP	extended the capacity planning function to human resource management and integrated it with production planning and financial administration	savings on cost for maintaining stocks
	PLM	sharing product data between over the whole supply chain and the whole product lifecycle	reduce not only manufacturing cost, but total life cycle cost of products

Table 5. Parallels between ERP and PLM established by (Silventoinen et al., 2011)

While the feature always seems something new, the aim is always to reduce the cost. However, the authors outline that “the real effect could very well be: dramatic reduction of product development lead time”. According to Silventoinen et al. (2011), the future of PLM would be to enable product-delivery within the near future needs of the customer. Indeed, this would enable to avoid waste by over-ordering, assuring stock and planning for unwanted products. However, this kind of pivot has not started to happen from an information system point of view despite academia having done some research work about management of reconfigurable manufacturing systems (Sabioni et al., 2021).

“A generation which ignores history has no past —and no future.”¹⁷ is a common saying. As an imperious necessity set out by the previous quote, these few elements have replaced PLM in its historical context and we will move on to defining what PLM is, today.

2.2.1.2 Definitions from academia

Terzi et al. (2010), throughout the process of proposing their own definition, outlined that they were three prior different currents of definition: the holistic concept, the ‘cradle to grave’, and the ICT perspective. Their definition of PLM is:

PLM can be broadly defined as a product centric – lifecycle-oriented business model, supported by ICT, in which product data are shared among actors, processes and organisations in the distinct phases of the product lifecycle for achieving desired performances and sustainability for the product and related services.

This definition is well-rounded and provides an equilibrium between the different components and features of PLM. This previous definition was rephrased by Hehenberger et al. (2016) as:

PLM is defined as a systematic concept for the integrated management of all product- and process-related information throughout the entire lifecycle, from initial idea to end of life.

However, this definition gives a better orientation of a few items but does not consider all the elements given by the original definition and it will be therefore left aside.

¹⁷ Common saying, originally from Robert A. Heinlein (1973), *Time Enough for Love*

A complementary approach to (Terzi et al., 2010), Kiritsis (2011) goes as follows:

Product Lifecycle Management (PLM) aims to manage the product related information efficiently during the whole product lifecycle. [...] PLM is a strategic approach and has three fundamental dimensions: (i) universal, secure, managed access and use of product definition information, (ii) maintaining the integrity of that product definition and related information throughout the life of the product or plant and (iii) managing and maintaining business processes used to create, manage, disseminate, share, and use the information.

These definitions will be compared to those of the software vendors in the next section to understand the gap between academia and practitioners' understanding of the matter.

On a sidenote, PLM has no equivalent translation in French - PDM on the contrary has *système de gestion de données techniques, SGDT* -.

2.2.1.3 About the return on investment in academic literature

Return on investment on IT PLM deployment is a key questioning of companies as the investment both in money and human resources needed to put it in place is substantial: Alemanni et al. (2008) mentions 2 to 7 years. No other mention in literature was to be found despite extensive grey literature and documentation being available on the internet.

Bokinge & Malmqvist (2012) argue that “there is a lack of studies that examine what guidelines are relevant for and used in real industrial PLM implementations, why (or why not) they are used, and what their value is if applied.” Therefore, the added value is hard to formally demonstrate. Despite this fact, the overwhelming majority of practitioners tend to agree on an existing return on investment. However, we hypothesize this might be due to a survivor bias.¹⁸ Concerning the ability to measure the performance and the return on investment (ROI) of a PLM system, Alemanni et al. (2008) propose a solution based on key performance indicators (KPI) for measuring quality, time,

¹⁸ “[Survival bias](#) is the logical error of concentrating on the people or things that made it past some selection process and overlooking those that did not, typically because of their lack of visibility”

cost, infrastructure & communication. Also, in the paper's conclusion, the authors advocate that more ROI will happen as time goes on. Walton et al. (2016) go further about "why is PLM value hard to calculate" and surprisingly argue that the existence of maturity models and vendors or consultants' reports should be enough to reassure the key-stakeholders and executives before going on with a research plan to formally demonstrate the added-value. Unfortunately, the framework is not developed at all, lots is left to the future and no follow-up data was to be found. Overall, Bokinge & Malmqvist (2012) "argue that systematic studies of real implementation efforts are essential to bring out and codify this knowledge." However, no further literature in this vein is deemed to exist. We shall keep this postulate as-is while keeping it in mind during discussion about the validation of our proposal and the future work possibilities.

2.2.1.4 About the current challenges for the PLM domain

Assessing current challenges is a struggle as what is foreseen in one era might not be what happens in the next. El Kadiri et al. (2016) outlines the current trends in ICT for enterprise information systems and synthesizes four great challenges summed-up in Table 6 below. The article does a fragment on ERP; however, PLM is not mentioned. We shall therefore investigate briefly what stands out for PLM.

Grand challenges	Related questions
Data Value Chain Management	How to allow data and information analysis, mining, integration, sharing, and security?
Context Awareness	How to offer contextual capabilities in complex business environments?
Usability, Interaction and Visualization	How to deliver new and intuitive ways for interacting with enterprise information systems (EIS)?
Human Learning and Continuous Education	How to support the development of professional competences triggered by new scientific and technological advances?

Table 6. “Four grand challenges in next generation enterprise information systems” from (El Kadiri et al., 2016)

We relate our research question to the “Data Value Chain Management” grand challenge as we aim to answer the data and information integration question between PLM and IoT.

Demoly et al. (2013) propose a route to go from a current-concurrent engineering to a future proactive engineering by linking “‘what’ with ‘how’ and ‘when’ contents, and introducing an emerging ‘why’ layer”. The emphasis of future PLM systems is put around knowledge management. With knowledge management comes ontologies and a further section is dedicated to interoperability, including ontologies. Nevertheless, we ought to mention, in context of PLM, that (ISO 15926-13:2018, 2018) specifies an ontology to facilitate PLM of multiple actors in the oil and gas industry.

Finally, the ISO/TC 184/SC 4 Industrial Data¹⁹ works on multiple standards that aim to tackle the current challenges faced by practitioners on a day-to-day basis.

¹⁹ <https://committee.iso.org/home/tc184sc4>, last accessed September 18, 2022

2.2.2 PLM as in PLM software

Terzi et al. (2010) view (Saaksvuori & Immonen, 2005) as having “investigated widely the ICT perspective of PLM”. However, the ICT-centred definition of PLM is very pronounced within the PLM vendors and practitioners’ community. For sake of completeness, we will investigate the four biggest vendors according to Quadrant Knowledge Solutions (Meher, 2019): PTC, Dassault Systèmes, Siemens and SAP. Other competitors listed are Oracle, Autodesk, and Aras.

PTC’s website (PTC, 2022) tackle’s its question “What is PLM?” as follows:

“Product lifecycle management software enables geographically dispersed, multi-disciplinary, teams to strategically collaborate with partners and customers using trusted, up-to-date product information.

Product lifecycle management is the foundation for the digital thread, delivering supply chain agility and business continuity. Data governance and traceability provided by product lifecycle management enables organizations to drive down costs, accelerate time to market, and deliver the highest levels of quality and compliance.”

PLM software is therefore defined even before PLM itself is defined, clearly stating out the existing bias. Moreover, the definition is *uninformatively circular* as the other terms are either not well referenced concepts, or ones that usually use PLM concepts to define themselves (such as *digital thread*).

Surprisingly, Dassault Systèmes does not display a definition for PLM on their website, despite having Enovia as PLM solution.²⁰

(Siemens, 2022) defines PLM as:

²⁰ <https://www.3ds.com/search/?wockw=PLM%2Bdefinition>, first accessed on July 27, 2021, last accessed October 13, 2022: search for “PLM definition” returns “There is no result”. No results were found through web search engines either.

“Product lifecycle management (PLM) is an information management system that integrates data, processes, business systems, and people in an extended enterprise.

PLM software allows to manage this information throughout the entire product lifecycle efficiently and cost-effectively: from ideation, design, and manufacture to service and disposal.”

(SAP, 2022) defines PLM as:

“Product lifecycle management (PLM) is the process of managing a product’s lifecycle from inception, through design and manufacturing, to sales, service, and eventually retirement.

As a technology, PLM software helps organizations to develop new products and bring them to market. The software makes it easy to track and share data along the product value chain, from initial design through manufacturing, supply chain management and operations, and asset maintenance.”

Please refer to the table of definitions in the Appendix to have an overview of all definitions at once. Overall, the definitions from the vendors do not tend to converge although putting forward most of the key items from the academia definitions.

2.2.2.1 PLM software functionalities studies

Until recently, comparing PLM software has been done nearly exclusively by research and advisory companies such as Gartner (e.g. (Halpern, 2006) or Quadrant Knowledge Solutions (e.g. (Mehtar, 2019)), or by consultancy firms on a smaller scale to advise clients on their PLM implementation projects. Recently, Enríquez et al. (2019) propose an approach to characterize and evaluate the quality of Product Lifecycle Management Software Systems. It compares various PLM software thought Figure 2-8. Moreover, Omerali & Kaya (2021) propose a fuzzy method based on multi-criteria decision making to ponder out bias from subject matter experts in a PLM selection process. In a more sectorial manner, (Bandinelli et al., 2021; Fani et al., 2020) work on a classification framework of the PLM software functionalities for the fashion industry. Overall, evaluation

frameworks could enable academia to offer a consolidated and unbiased point of view on the functionalities.

Basic/ core components of a PLM System	Dassault Enovia V6	Siemens TeamCenter V9	PTC WindChill 10	Trace One	CATIA PLM	ARAS	Oracle Agile PLM
Requirements and specifications management	Yes	Yes	Yes	Yes	Yes	Yes	Yes
Data/ document management	Yes	Yes	Yes	Yes	Yes	Yes	Yes
Part/ production / configuration management	Yes	Yes	Yes	Yes	Yes	Yes	Yes
Process/ workflow management	Yes	Yes	Yes	Yes	Yes	Yes	Yes
Program/ project management	Yes	Yes	Yes	Yes	Yes	Yes	Yes
Collaboration management	Yes	Yes	Yes	Partially	Yes	Yes	Yes
Visualization	Yes	Yes	Yes	No	No	Yes	Yes
Integration applications	Yes	Yes	Yes	No	No	Yes	Yes
Product portfolio management	Yes	Yes	Yes	No	Yes	Yes	Yes
Collaborative product definition management	Yes	Yes	Yes	Partially	Yes	Yes	Yes
Supplier and sourcing management	Yes	Yes	Yes	No	Yes	No	Yes
Manufacturing management	DelmiaV6	TecnoMatrix	Yes	Yes	Yes	Yes	Yes
Maintenance/ service management	Yes	Yes	Yes	No	Yes	Yes	No
Extension components of a PLM system	Dassault Enovia V6	Siemens TeamCenter V9	PTC WindChill 10	Trace One	CATIA PLM	ARAS	Oracle Agile PIM
Concepts							
Idea management	No	No	No	No	No	No	Yes
Idea generation management	No	No	No	No	No	No	Yes
Design							
Compliance, environment, health and safety management	Yes	Yes	Yes	Partially	Yes	Yes	Yes
Product analysis, validation and simulation	SimuliaV6	TecnoMatrix	PTC Creo	No	Yes	Yes	Yes
Authoring Tools: CAD, CAE, CAM, ECAD, CASE...	CATIA/SW	NX/SEdge	PTC Creo	No	Yes	Yes	Yes
MultiCAD management	Yes	Yes	Yes	No	Yes	Yes	No
Software development	Partially	Partially	No	No	Yes	Yes	Yes
Technical documentation	Yes	Yes	Yes	No	Yes	Yes	Yes
Technology planning	Partially	Partially	No	No	No	No	No
Production							
Digital manufacturing	SimuliaV6	TecnoMatrix	No	No	Yes	Yes	No
PLC programming	Delmia	TecnoMatrix	No	No	Yes	No	No
Support/ Use							
After sales management	Partially	Partially	Partially	No	No	Yes	No
Marketing	3DExcite Mar	No	No	No	No	No	No
General							
Intellectual Property management	Yes	Yes	Yes	Yes	Yes	Yes	Yes
Quality lifecycle management	Yes	Yes	Yes	Yes	Yes	Yes	Yes
Communities of practice	Yes	Yes	Yes	Yes	Yes	Yes	Yes
Infrastructure management	Yes	Yes	Yes	Yes	Yes	Yes	Yes
Distribution	Partially	Partially	No	Yes	No	Yes	AVM**

*In some cases, it is known by the name of the tool or application of the provider that renders support to the field, but it is not a part of the analyzed suite. Therefore, the value for the study will be "No" in the specific characteristics.

** Agile variant management.

Figure 2-8. "Evaluation of PLM systems of different companies from the proposed model.", from (Enrquez et al., 2019)

2.2.3 IT PLM key concepts for the proposed methodological framework

PLM has matured over the past decades into a quite complex ecosystem to address the needs of the industry. We will not describe all the functionalities that IT PLM might or might not have. However, we will outline three of them which are going to be useful to elaborate our methodological framework proposition: baseline, change management, and product instantiation.

2.2.3.1 Defining Baseline

A baseline, also called a configuration baseline, is defined by Piquié et al. (2015) as “a formally-approved configuration at key milestones of the product lifecycle”²¹. Product data and technical objects are then part of a given baseline as represented in Figure 2-9 below.

Depending on the industry, the number of baselines may vary; they are referred to as ‘As-X’ terms. Our proposed methodological framework will include the following ones: “As Required”, “As Defined”, “As Developed”, “As to be Built” and “As to be Maintained”. Moreover, we will rely on two additional baseline-like items that define the current configuration (vs. the formally approved one) of a product at given stages in the product lifecycle: “As Built” and “As Maintained”. Some of these baselines often rely on associated Bill of Materials (BOM).

2.2.3.1.1 *As Required*

The As Required baseline is often part of the requirement management. Its aim is to put together the product features and the properties that will answer the need of a stakeholder or client. Challenges in this phase are to make the requirements explicit (vs. implicit), to ensure those requirements are verifiable, and that they answer the need of the stakeholder or client.

At this point, work products are often documents called *User Requirements Document* or *Specification* (URS/URD) if the project has an external client or *System requirements specification* (SRS) for any stakeholder.

2.2.3.1.2 *As Defined*

The As Defined baseline follows the previous and aims to fill-in the eventual gaps or ‘TBD’ (To Be Decided) elements of the previous baseline. Often, architectural choices are made in order to

²¹ a milestone being “particular instant t of the product lifecycle” that “characterize[s] the transitions from one phase of a product lifecycle to another”, (Piquié et al., 2015)

define sub-elements that will be developed concurrently. Rough schematics and drawings are made in order to define the products' skeleton.

Work products of As Defined baselines are rough bill-of-materials and respective engineering artefacts; for instance, a connected device would have a mechanical, an electronic and a software requirement specification.

2.2.3.1.3 As Developed

This baseline aims to complete the product with detailed designs for each component. The previously built skeleton is fleshed out: Mechanical drawings are completed, electronic boards and components are created, the software is developed.

The transition between As Defined and As Developed is often regarded as the one where PLM software is most helpful as numerous iterations are required to adapt the products design to the product definition or the opposite as, given a product's complexity, the choice can be made to tweak the definition to facilitate, or even sometimes enable, a product's design.

The associated BOM is the Engineering BOM or EBOM.

2.2.3.1.4 As to be Built and As Built

The As to be Built (or As Planned) baseline converts the As Developed baseline based on the current tooling available at a given production site. Indeed, two different production sites might have different processes to fulfil a given work-order based on the equipment or expertise locally available.

The As to be Built baseline is the "formally approved configuration" whereas the As Built or (As Manufactured) baseline is the result of the manufacturing and assembly operations with all the waivers, deviation and often mistakes or imprecisions that might have contributed to the production of a given product.

The associated BOM is the Manufacturing BOM or MBOM.

2.2.3.1.5 As to be Maintained and As Maintained

Similarly to the previous baseline, the As to be Maintained is the “formally approved configuration” whereas the As Maintained is the result of the field experience.

The associated BOM is the Service BOM or SBOM.

2.2.3.1.6 Component representation

The baselines are encompassed within the idea of a Product Lifecycle Management in its academic definition although the software vendors often break up the underlying software systems into multiple software platforms.

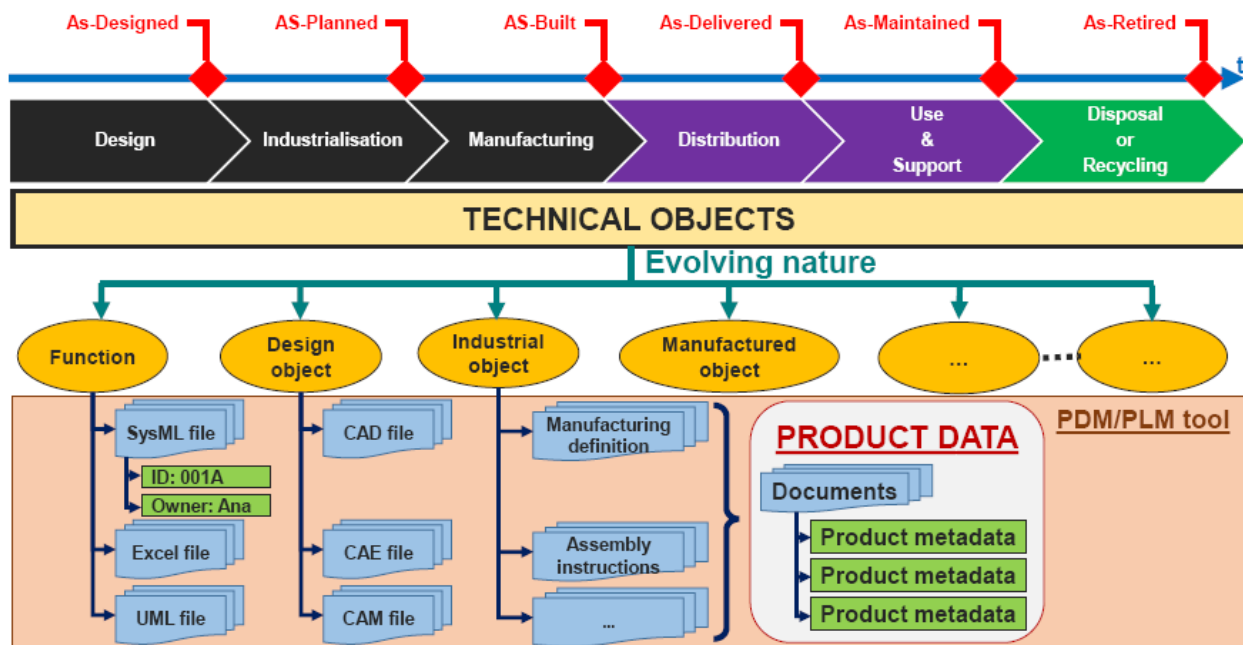

Figure 2-9. “Product data”, from (Pinquié et al., 2015)

2.2.3.2 Change Management

Engineering change process, often simply shortened to change management in engineering context, is a key process within a given company as it enables to make and document decisions regarding a given product’s development (Rouibah & Caskey, 2003). Pinquié et al. (2015) define engineering change process as “a set of interrelated change activities that characterises the evolution from a product data revision A to a product data revision B.” In small entities and for simple products, change can be made in a single meeting, but as organisations grow and/or as products become more complex, the process needs to be more structured. It aims to ensure the product’s evolution is done

in a reasonable way from multiple stakeholder's perspective: design department, purchasers, factory, support, etc. As such, it is often managed within PLM software through workflow-type solutions to guide user activity and ensure compliance with the process. In an equivalent way to what we did not do with the baselines, we do not intend to generalize how this process should happen. We only present how one could work to illustrate our proposition. Indeed, a process will be different from one organisation to the next and might respond to an industry's particular need. For instance, a pharmaceutical industry will look toward more documentability whereas an engineering-heavy structure will focus on the technical underlying aspects.

2.2.3.2.1 Process overview

We shall outline here what the interrelated change activities might look like. As illustrated in Figure 2-10 below, the initial step will be a problem report (PR) or a request for change (RFC) then might follow a change request (CR), a change proposal (CP), a change order (CO), and end with a change notice -. We will also address exception handling which most often takes the form of deviations & waivers.

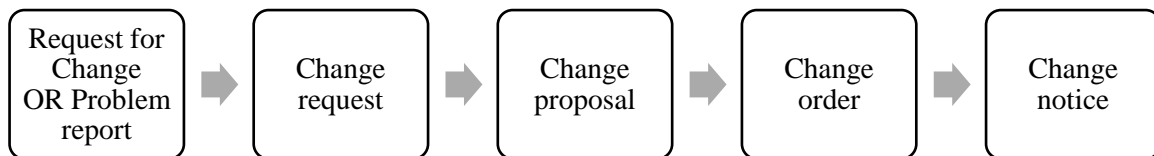

Figure 2-10. An engineering change process overview

2.2.3.2.2 Initial step: Problem report or Request for change

A problem report contains details of an issue that occurred. This could be a product being broken but also underperforming, behaving weirdly or even working well but with a suspicious sound to it. A request for change might come from users requesting new features to be added or from manufacturing teams to enable process harmonization on the shop floor. This initial step can sometimes take other names and forms depending on the organisation: Customer RFC, Internal Improvement, etc... Overall, they can be generalized as rationales for change.

No all PRs and RFCs lead to a modification. Problem reports might be discarded for several reasons: the reported product might not have been serviced or maintained correctly, might have

been used incorrectly or cannot be diagnosed further. Similarly, request for change might be too costly to consider and might be disregarded.

Often, multiple PRs or RFCs are consolidated into a single change request.

2.2.3.2.3 The steps in-between

A change request comes in when a given problem has been widely accepted. An impact analysis is then conducted to check for any side effect that changes might have on the environment: on the product, the production, the existing customer base, etc... Once a change request has been completed, it moves on to become a change proposal where a given solution is proposed with the adequate data surrounding it: what are the changes on product quality, the potential delays or extra costs, and the risks to be considered. It then goes through a committee process where key stakeholders, often subject matter experts, review the given proposal and either refuse or accept the proposal. Following an accepted change proposal, all the detailed work and consolidation is carried out to produce a change order that will implement the agreed-upon change.

It is less common that companies actively shelve change process once they have started given the associated efforts to do so. However, the process can stall at any time given the number of stakeholders and the complexity involved. It is therefore key that such process be correctly put in place and tooled within a company to avoid any overhead due to misunderstanding or misinterpretation.

2.2.3.2.4 Last step: Change notice

Finally, all the pieces are in place for the change to happen. At that moment, a change notice is issued and sent to all the relevant actors. A change notice might only affect the As to be build baseline or be wider than that and change all of a product's baselines. For instance, due to limited availability of a purchased component, products often must be reworked in a major way.

Sometimes, change notices go beyond the company's scope and needs to be acted upon by clients that must then issue an internal request for change and go through a change process themselves. For instance, a change in an electronic component will impact the numerous clients relying on it for their own products.

2.2.3.2.5 Deviations and Waivers

Despite having a formalised process in place, some issues might arise and need to be addressed with exception handling. The most common ones are deviations and waivers. A deviation is a gap which is accepted by the client for a given period. A waiver is a gap which is accepted by the client for a given production batch. Deviation will most often be agreed ahead of the production when the manufacturer knows he will not be able to achieve a specification, whereas the waiver is most often used when an already produced batch has a minor defect which can be accepted by the client (slightly out of tolerance for instance).

2.2.3.2.6 A quick example

A problem report might be that “the device is overheating.” Once multiple similar reports come in, the engineering team will create a change request: “Fix the overheating issue.” Will then follow in a change proposal “add a heat sink”, that will then be followed by change order “design a 4mm x 4 mm heat sink” and a change notice “here is the new heat sink; please manufacture the next products batches with the head sink added”. Such a change process is illustrated in Figure 2-11 below.



Figure 2-11. A change process example

2.2.3.3 Product and Product Instantiation

When one refers to a product, they might be either referring to a product or to its instantiation. For instance, talking about the bicycle (product) or about Joe's bicycle (product instance) are two different things. A product is defined by Pinqu   et al. (2015) as:

“Product: the result of a process, that is, the result of a set of interrelated or interacting activities that transform inputs into outputs (ISO 9000:2005, 2005).

A product can be tangible and/or intangible. An intangible product can be a

service or not a service. A product can be a sum of products. A product can include the products which constitute the environment in which it operates. A product can include the missions it must fulfil. Generally, a product is a blend of these properties.”

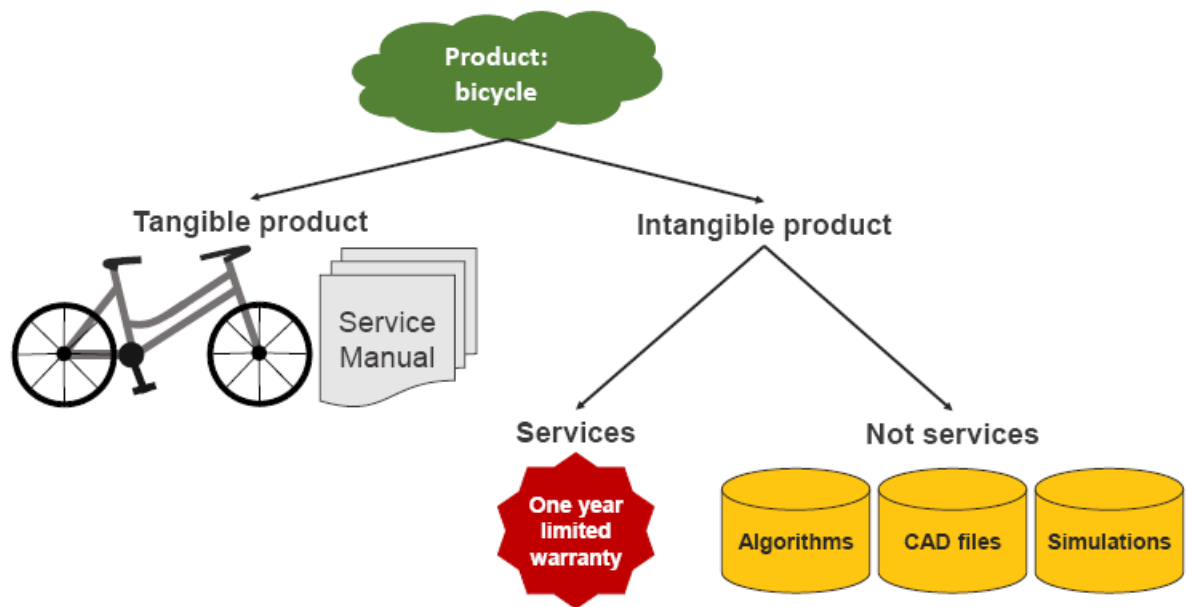

Figure 2-12. “Product”, from (Pinquié et al., 2015)

One can refer to Figure 2-12 above for an illustration of the definition. Using a similar definition, RAMI 4.0 differentiates “product type” from “product instances”. Going further, Nyffenegger et al. (2018) considers them as being two different lifecycles with four interaction processes in-between: definition, instantiation, usage, and generalisation as depicted in Figure 2-13 below. The product type space could be considered equivalent to IT PLM whereas the product instances space could be considered closer to IoT platforms. Indeed, definition is core to IT PLM while usage and particularly usage data is core to IoT platform. Therefore, instantiation is then the transition from IT PLM to IoT Platform while generalisation is the reverse transition from the latter to the former. Unfortunately, no roadmap is proposed about how to integrate this into information system’s roadmaps in order to ensure the digital thread and we shall attempt to close this gap with our proposition.

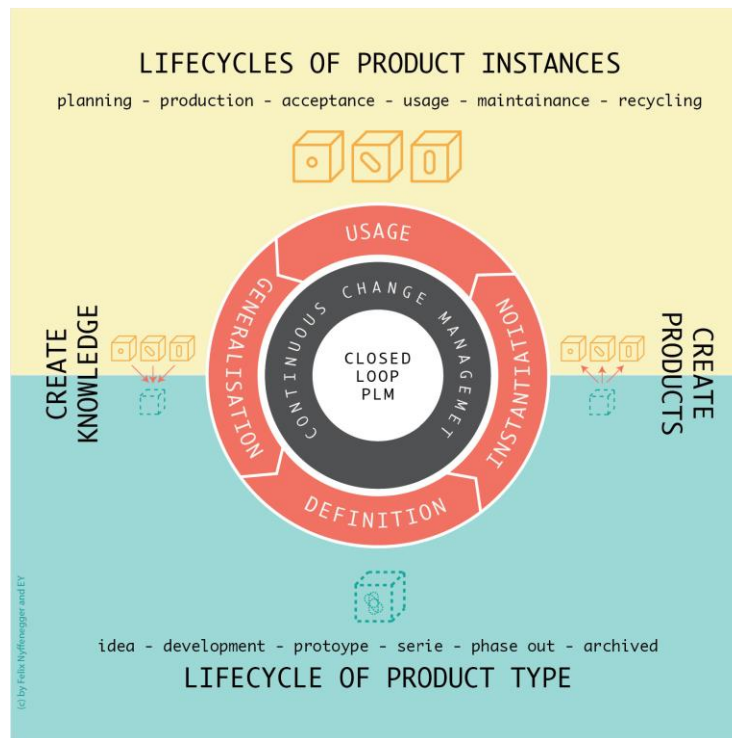

Figure 2-13. “The essence of product type and product instance and the four processes of interaction between them”, from (Nyffenegger et al., 2018)

2.2.4 Reflecting PLM and IT PLM on the problem statement

Throughout this section, we first approached PLM from an academia perspective: its recent history as well as outlining the existing consensual definitions. We also challenged the return-on-investment consensus by outlining the lack of formal proof so far. Moreover, we exposed IT PLM from the practitioner’s standpoint and put forward a few studies on IT PLM functionalities. Finally, we presented the IT PLM features that will be useful in the upcoming proposition, namely Baselines, Change Management, and Product and its instantiation.

Overall, this section demonstrated the maturity of PLM as a concept while outlining the gap between the PLM academia concept and its embodiment from practitioners and software vendors through IT PLM. When looking towards the problem statement, we therefore will have to wary when trying to ensure a digital thread between PLM and IoT as this could go via IT PLM as well as leveraging other concepts of PLM that are not necessarily found in IT PLM.

2.3 IoT and IoT Platforms

IoT was covered in the introduction and defined as follows:

Internet of things is an infrastructure of interconnected entities, people, systems, and information resources together with services, which exchanges information between physical and virtual world by sensing, processing information and actuating

Throughout this section, we shall first outline the results from a research work done by the author in collaboration with a student on IoT Platforms. We then will present results of systematic literature review published in 2019 and 2022. Finally, and based on the previous, we will outline IIoT information structuration as it is a key feature for our proposition of methodological framework.

2.3.1 IoT Platform features and choice help: (Santana et al., 2021)'s findings

(Santana et al., 2021) is the result of a collaboration with an UTC student in MSc of Mechanical Engineering, Jussara Santana, during a semester-long practical and experimental course. Despite the term “IIoT platforms” having been used throughout the article, we will here talk about “IoT Platforms” as depicted in 1.2.2 IoT as the global research position.

Results are first the key features of an IoT Platform and second a methodology proposition for industrials to pick a relevant IoT Platform.

2.3.1.1 Key features for an IoT Platform

Based on a literature review, Santana et al. (2021) describe the key features that are features of an IoT Platform and sums it up as presented in Table 7 below.

	Connectivity	Device management	Data visualization	Data analysis	Security	Database
(Choi et al., 2018)	x	x	x			
(Zdravković et al., 2016)	x	x	x	x	x	
(Kim et al., 2019)	x			x	x	x
(Ullah et al., 2020)	x	x	x	x	x	
(Gartner, 2020)	x	x	x	x	x	x

Table 7. IoT Platforms features according to articles, translated from (Santana et al., 2021)

2.3.1.2 Methodology proposition for industrials to pick a relevant IoT Platform

In addition to the features presented above, Santana et al. (2021) add cloud computing and real-time data analysis to the selection criteria. Each criterion is then pondered, and platforms are graded in two categories: open-source platforms and proprietary platforms. Respectively, ThingsBoard for open-source and Ixon IoT, Davra IoT and ThingWorx for proprietary platforms got the best grades. Given the evolution of IoT Platforms, those results have evolved since the article's publication as one could notice from, for instance, (Gartner, 2021) whereby Software AG and Siemens have joined the main actors along Microsoft, PTC and Hitachi compared to (Gartner, 2020).

The article then does a demonstration of the IoT platform taking a production line as example before discussion and conclusion.

2.3.2 Joint literature on PLM and IoT

(ITU-T Y.4003, 2018)²², a recommendation on IoT for Industry, mentions PLM as one of the specific service support capabilities of IoT, without going at all into further details. The author has, over time, done two systematic literature reviews to map out the existing literature: (Barrios et al., 2019a) was done only on journal articles while (Barrios et al., 2022) refreshes the previous and includes all bodies of literature. Please refer to the original articles for completeness, the aim here is to sum up the findings and useful insights for this thesis.

2.3.2.1 PLM and IoT SLR: (Barrios et al., 2019a)'s findings

Barrios et al. (2019a) proposes a systematic literature review (SLR) of the joint literature of Internet of things and product life cycle management to highlight the to-2018 situation. The aim was to find how the link between PLM and IoT was done in literature. Although some systematic literature reviews existed separately for internet of things and product lifecycle management, none could be found concerning both topics. The systematic literature review was done in Scopus and Web of Science (WOS) and searched for all the journal articles written in English that mentioned both PLM or IoT domain in these terms: {PLM, Product Lifecycle Management} and {IoT, IIoT, Internet of Things, Industrial Internet of Things}.

Following the merger of both search results, 26 unique articles were left. Out of these 4 were irrelevant and 8 were put aside for only implicitly relating to PLM or IoT. Out of the 14 remaining, 2 were reviews or surveys, 5 were theoretical solutions, 4 were experimental laboratory solutions and only 2 were practical industrial solutions. The spread per year is displayed in Figure 2-14 below.

²² Already introduced previously in 2.1.1.3.5 ITU (p.42)

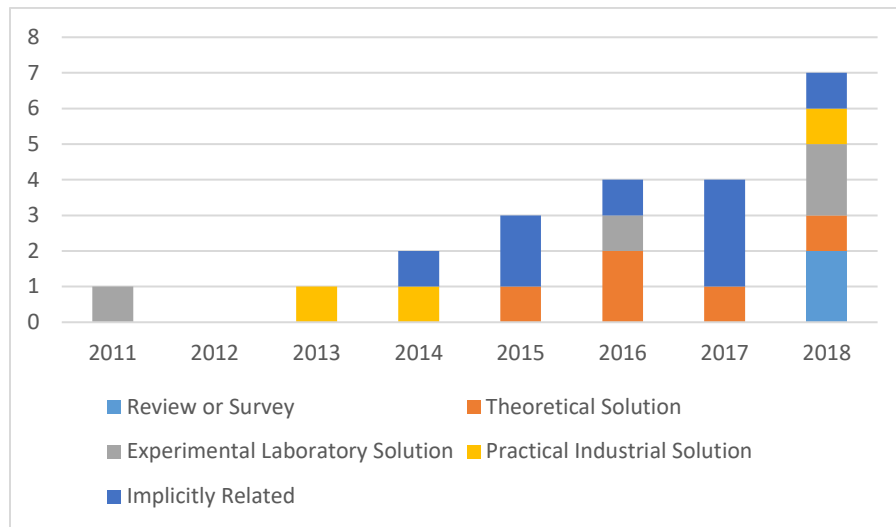

Figure 2-14. Number of journal articles per category per year, from (Barrios et al., 2019a)

One of the main items I had noticed was the important presence of ontologies. Indeed, many articles mentioned it resulting in an overrepresentation compared to the industry – Industry being more used to integration semantic interoperability. This will be discussed further in section 2.4 Interoperabilitybelow.

2.3.2.2 PLM and IoT SLR: (Barrios et al., 2022)'s findings

(Barrios et al., 2022) consists of two main parts. The first part is an updated and extended SLR with the same method as previously and the second part is a teasing of this thesis' proposition which will be developed from Chapter 3 onwards. The update to the SLR was extended with all types of literature, including conference articles.

2.3.2.2.1 Methodology

The SLR review keywords and search requests in Scopus and WOS are detailed in Table 8 below. On November 27th, 2021, the search returned 132 unique articles which were then funneled down with the criteria given in Table 9 below.

product lifecycle management	AND	Internet of things
PLM		industrial internet of things
		IoT
		IIoT
<p><i>Scopus: TITLE-ABS (("IOT" OR "Internet of things" OR "IIOT" OR "industrial internet of things") AND ("PLM" OR "product lifecycle management")) OR AUTHKEY (("IOT" OR "Internet of things" OR "IIOT" OR "industrial internet of things") AND ("PLM" OR "product lifecycle management")) AND (LIMIT-TO (LANGUAGE,"English"))</i></p>		
<p><i>Web of Science: ((TI= ("IOT" OR "Internet of things" OR "IIOT" OR "industrial internet of things")) AND ((TI =("PLM" OR "product lifecycle management")) OR (AB =("PLM" OR "product lifecycle management")) OR (AK =("PLM" OR "product lifecycle management")))) OR ((AB= ("IOT" OR "Internet of things" OR "IIOT" OR "industrial internet of things")) AND ((TI =("PLM" OR "product lifecycle management")) OR (AB =("PLM" OR "product lifecycle management")) OR (AK =("PLM" OR "product lifecycle management")))) OR ((AK= ("IOT" OR "Internet of things" OR "IIOT" OR "industrial internet of things")) AND ((TI =("PLM" OR "product lifecycle management")) OR (AB =("PLM" OR "product lifecycle management")) OR (AK =("PLM" OR "product lifecycle management"))))</i></p>		

Table 8. Systematic literature review keywords and search requests, from (Barrios et al., 2022)

I/E	Criteria	Description
Exclusion	Duplicate Papers (DA)	The same article appears multiple times in one or more databases.
	Without Full-text (WF)	The authors of this work are without access to the full-text of the article.
	Wrong Categorization (WC)	The source of an article is misclassified.
	Non-English Article (NEA)	The article is not written in English.
	Non-Research Article (NRA)	The article is not a research article, e.g., an editorial note, a magazine article.
	Non-Related (NR)	The definition of IIoT, IoT or PLM is out of the research context of this work, e.g., PLM stands for Patient's Local Module.
	Wrongly Related (WR)	The characters in an article are mismatched during the text conversion (in the case of old papers). For example, recognizing the image "Hot" or "not" as the "iiot".
	Implicitly Related (IR)	The article does not explicitly express its research focus on IIoT & PLM, e.g., focuses on PLM while only mentioning IoT.
Inclusion	Review or Survey (RS)	The article presents a review, or a survey related to IIoT & PLM.
	Theoretical Solution (TS)	The article aims to solve some specific IIoT & PLM integration research problems and gives some theoretical propositions.
	Experimental laboratory Solution (ES)	The article aims to solve some specific IIoT & PLM integration research problems, gives some solutions, and provides laboratory experiments.
	Practical industrial Solution (PS)	The article aims to solve some specific IIoT & PLM integration research problems, gives some solutions, and provides industrial implementations.

Table 9. Table of criteria for SLR, from (Barrios et al., 2022)

2.3.2.2.2 Results

Process and associated results are developed in Figure 2-15 and Figure 2-16 below.

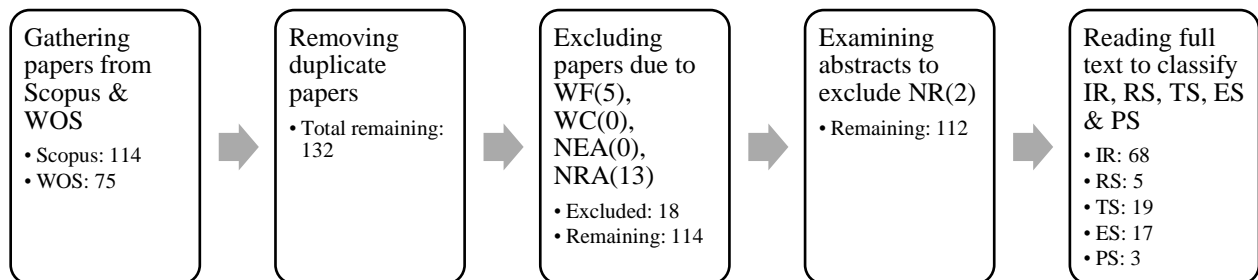

Figure 2-15. SLR process steps with associated results, from (Barrios et al., 2022)

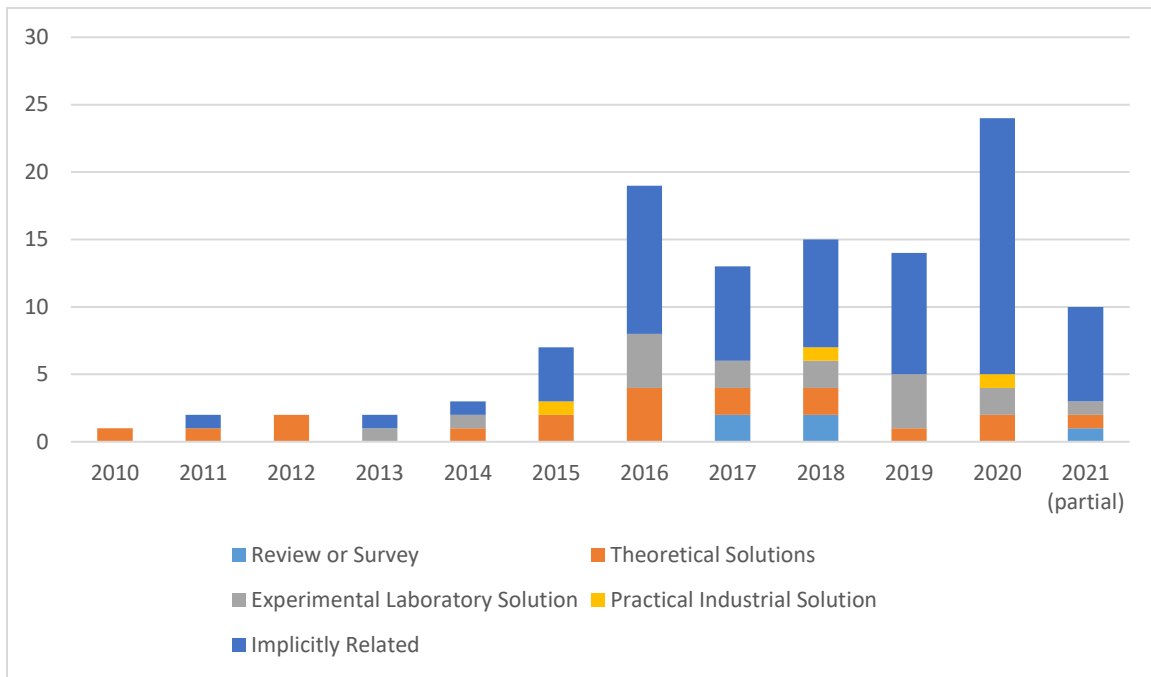

Figure 2-16. Number of articles per category per year in (Barrios et al., 2022)

2.3.3 The fourth key feature for the proposition: IoT Information Structuration

As outlined until now, IoT is an evolving domain, and the capabilities of the domain are to be addressed throughout the different maturity phases. (Barrios et al., 2022) shows that IoT was often a synonym for a product identification system or product embedded information device (PEID, e.g., RFID) at the beginning of the decade, to progressively become a synonym for a sensor capable of collecting, processing, and sending data. The latest evolution is IoT as an actuator, capable of acting upon either information or orders received. However, this is not yet reflected on in the joint PLM-IoT literature. This outlines the necessity to propose a system which will be able to evolve and adapt to IoT's future trends. We can therefore categorize IoT platform data as being product identification, sensor data and actuator details.

2.3.4 Reflecting IoT on the problem statement

Extending on section 1.2 Research positioning: IoT or IIoT?, this section outlined the various works of the author on IoT. First, we presented the features of IoT Platforms and a methodology for choice

help. Then we covered the two systematic literature review published in 2019 and 2022 that depicted a transformation of the IoT landscape surrounding PLM since the early 2010's. Finally, based on the previous literature reviews, we outlined a structuration around IoT enabling and taking into account future things' evolution around actuating capabilities.

Overall, this section outlined the foginess surrounding the structuration of the IoT domain despite starting to have key reference points and some IoT platforms maturing. Some PLM-IoT joint research start to outlay interesting elements to build on but however do not provide the full picture of how the gapping between the two should happen.

We shall now turn ourselves toward the digital thread component of the problem statement to see how to define and describe the gap between both concepts and their respective information system. To do so, we will address successively interoperability, Digital Twin and Cyber-Physical Systems.

2.4 Interoperability

Making things work together is key to a system functioning correctly. In our case, we need to get PLM to work with IoT and to describe in a formal way how that can happen: Interoperability. (ISO/IEC 2382:2015, 2015) defines interoperability as the

<fundamental terms> capability to communicate, execute programs, or transfer data among various functional units in a manner that requires the user to have little or no knowledge of the unique characteristics of those units

This standard however does not define precisely what a user is in a general context. Nonetheless, one must keep in mind that a user can be a final user (a person) or a user agent (an intermediate computer or software system): the system can be composed of a final user trying to access through a myriad of user agents. It is necessary to situate the level of discussion when interoperability is mentioned. In that sense, the (European Commission. DGI., 2017), also known as the European Interoperability Framework (EIF), promotes an interoperability model composed of:

- Four layers of interoperability: legal, organisational, semantic, and technical;
- a component cross cutting the four layers, 'integrated public service governance';
- a background layer, 'interoperability governance'.



Figure 2-17. “Interoperability Model”, from (European Commission. DGI., 2017)

However, Chen et al. (2008) criticizes the EIF: “These interoperability aspects (semantic, technical, organizational, etc.) reflect more interoperability issues or problems rather than levels of operational entities where interoperation take place by exchanging information.”

To dive further into works addressing organisational interoperability, one can look to (Chen et al., 2008). Our concern here focuses on the information systems surrounding a given process rather than on an organisation. We shall therefore dive further into semantic interoperability.

2.4.1 Semantic interoperability

Fortineau (2013) and Danjou (2015) have extensively investigated state of the art around semantic interoperability. For non-French-speaking readers, we shall attempt a summary here before discussing the impact on our research question. (ISO 14258:1998, 1998) puts forward three types of interoperability: Integration, Unification and Federation.

2.4.1.1 Integration

Integration is based on the existence of a generic format for all systems. An integration process amounts to merging the data models. From previous literature, Fortineau (2013) outlines its limits:

- Because it seeks a consensus between the different actors of the network, integration can only present a limited level of compatibility with each actor. Indeed, it is not possible to

propose a model that adapts perfectly to each actor since this model must be suitable for all.

- Integration is often considered to go further than interoperability, by forcing a certain functional dependency of applications.

2.4.1.2 Unification

Unification is based on a generic format that only exists at an elevated level. It is a meta-model common to all components of the system which provides a means to establish semantic correspondences. To establish these links, it is necessary to be able to translate the semantics and find the correspondences (mapping) between the semantics, as a linguist would establish a dictionary between two different languages. For this, a central pivot model is used as a mediator and its choice can proceed from two approaches: either the definition of a specific ad hoc model as needed; or the choice of a standard model, i.e., standardized, and open.

2.4.1.3 Federation

Federation is based on the use of ontologies and semantic standards for the automation of the transfer and routing of information between heterogeneous applications. Indeed, distinct models are dynamically associated. This approach relies on semi-automatic tools, based on heuristic methods that mainly compare terminology and data structure to detect pairs of concepts that are related at the semantic level (similarity or equivalence).

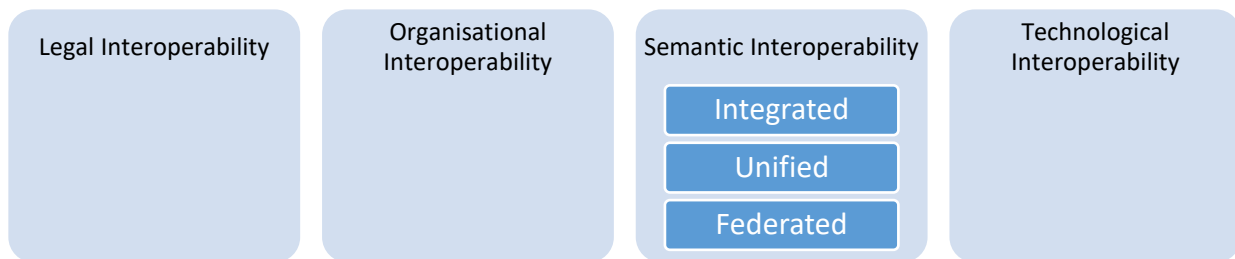

Figure 2-18. Interoperability Model, adapted from (European Commission. DGI., 2017) & (ISO 14258:1998, 1998)

2.4.1.4 Recommendations around semantic interoperability type choice

Paviot (2010) states that « face aux efforts encore nécessaires pour mettre au point la fédération des modèles de données, nous déconseillons cette approche si l'industrialisation de la solution proposée est envisagée à court terme »²³. Therefore, given the possibilities in terms of Semantic interoperability, we shall position the various concepts in such way that they could be easily reused to ensure semantic interoperability; whatever the type of interoperability an industry wants to achieve. Nevertheless, we want to pinpoint that federated approaches are still immature and multiple initiatives are currently being conducted to bridge the gap at OntoCommons²⁴. For instance, Industrial Ontology Foundry (IOF)²⁵ aims to create an ontologies to support the manufacturing and engineering industry needs. Given this, Integration or unification are *de facto* the recommended approaches for ensuring a semantic interoperability between PLM and IoT.

2.4.2 About the difficulty of migrating a PLM system

Given the new context brought by IoT, one could dream about migrating and integrating all the existing IT PLM data along with IoT data into an information system of a new breed. However, research conducted by the author with François Loison on IT PLM data migration strategies demonstrated that even with F. Loison's expert knowledge and big data tooling, this kind of approach was cost and resource intensive as well as extremely risky (Barrios et al., 2020; Loison et al., 2020). As IT PLM has a strategic position within a company's information system; it also enables the company to have a competitive advantage such as faster time to market, as most companies will not be looking towards attempting such a risky move. A good example of reluctance to change PLM is proposed in (Fortineau, 2013): she argues that integration of maintenance is still uncommon in IT PLM despite having been clearly identified as part of PLM since 2005.

²³ “Given the efforts still necessary to develop the federation of data models, we do not recommend this approach if the industrialization of the proposed solution is envisaged in the short term”.

²⁴ <https://ontocommons.eu/>, last accessed September 25, 2022: “OntoCommons is an H2020 CSA project dedicated to the standardisation of data documentation across all domains related to materials and manufacturing.”

²⁵ <https://ontocommons.eu/initiatives/industry-ontology-foundry>, last accessed October 15, 2022

2.5 Digital Twin and Cyber-Physical Systems

2.5.1.1 Digital Twin

Digital Twin seems like a buzzword today in an analogous way Internet of Things was a decade ago. Many a stakeholder has mentioned the term without defining it clearly. Therefore, we shall examine definitions from ISO before looking into academia.

“Automation systems and integration — Digital twin framework for manufacturing” (ISO/FDIS 23247, 2021) defines a Digital Twin in an indirect definition: a Digital Twin is “fit for purpose *digital representation* of an observable manufacturing element with synchronization between the element and its digital representation.” A digital representation is defined as a “data element representing a set of properties of an *observable manufacturing element*.” An observable manufacturing element (OME) is an “item that has an observable physical presence or operation in manufacturing” and “include personnel, equipment, material, process, facility, environment, product, and supporting document.” This definition of Digital Twin is very minimalist as no detail is given. What is meant by “synchronization”? When is it supposed to happen? How? Etc. Moreover, the definition seems to repeat itself as a digital representation is necessarily that of an OME. Therefore, we propose the following modification to (ISO/FDIS 23247, 2021):

A Digital Twin is a fit for purpose digital representation ~~of an observable manufacturing element~~ with synchronization between the element and its digital representation

Given the narrowness of the (ISO/FDIS 23247, 2021) definition, we turn towards academia to understand better the underlying concept, use-cases, and overall domain.

Weber et al. (2017) present a Maturity Model for Data-Driven Manufacturing (M2DDM) which defines a Digital Twin stage (stage 4) as follows:

“This [Digital Twin] concept is still under development but represents the way to a decentralized self-control of assets on the shop floor. An essential aspect herein is a uniform data model for the description of manifold assets. The concept included is a common vocabulary, which forms the data model. Only through this uniform data model can different assets from different plants form a holistic intelligence which allows for decentralized self-control. From our point-of-view the Digital Twins of every asset should be integrated by a central platform. This does not imply that

we focus on the traditional centralization of controls for the manufacturing process, rather we state that human-specific decisions should base on a centralized platform for monitoring decentralized and autonomous assets. This keeps the human in the loop and allows for controlled interventions that cannot be handled by smart assets.”

This definition is built from an information modelling point of view and does not encompass the level of detail necessary and the data storage space. However, it clearly positions the debate in terms of centralization and decentralization as well as contribution of the human in the loop. The latter could be put in parallel with similar questioning that happened with PLM’s emergence.

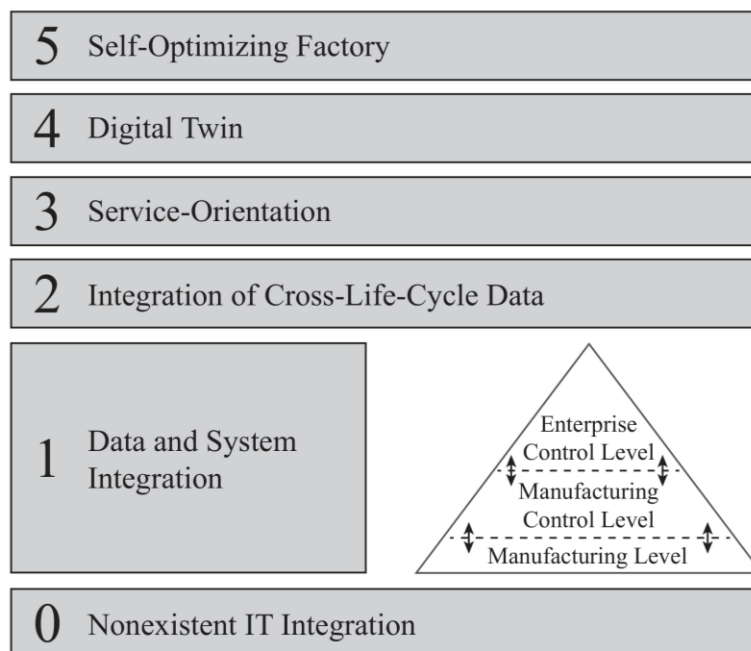

Figure 2-19. Maturity Model for Data-Driven Manufacturing, from (Weber et al., 2017)

From Figure 2-19 above, we notice that Digital Twin is only considered by Weber et al. (2017) as an intermediate step in the maturity model. The first steps are standard in terms of proposition but however, the last step is the self-optimizing factory. This concept relies on context-sensitive data and enhanced edge analytics to optimize the feedback loop. To date, this seems like quite a journey.

As they considers there is an “incomplete understanding” of the concept, Kritzinger et al. (2018) distinguish Digital Model, Digital Shadow and Digital Twin based on the level of integration and data flow between the physical object and the digital object as represented in Figure 2-20 below.

The Digital Twin, being the highest development stage, is characterized by an automatic data flow in both directions between the physical object and the digital one.

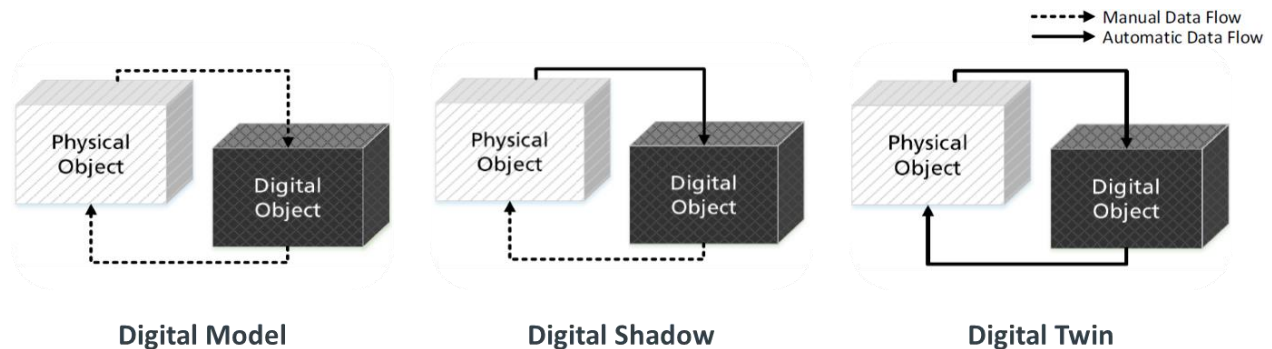

Figure 2-20. Digital Model, Shadow, and Twin, according to & adapted from (Kritzinger et al., 2018)

Finally, “Visualization elements of Digital Twins” (ISO/TR 24464:2020, 2020) considers that Digital Twin and Cyber-Physical System “are similar and a candidate to replace each other.”

Overall, the definition of a Digital Twin is non-consensual despite a promising looking concept. We reflect further upon it in Chapter 6 Discussion.

2.5.2 Cyber-Physical Systems

Cyber-Physical System (CPS) are “systems of collaborating computational entities which are in intensive connection with the surrounding physical world and its on-going processes, providing and using, at the same time, data-accessing and data-processing services available on the Internet” (Monostori et al., 2016). The DT is related to the CPS and is seen as its digital counterpart (Cimino et al., 2019). Therefore, the physical system that is mirrored by a Digital Twin can be considered a Cyber-Physical System. Given that the said system necessarily included IoT, IoT is therefore an enabling technology for Cyber-Physical Systems. Cyber-Physical systems can be seen as an intermediate step between Mechatronics and Internet of Things as shown in Figure 2-21 below (Hehenberger et al., 2016). Moreover, and regarding the 5C architecture, which is often connoted with Cyber-Physical Systems, we defer to the dedicated paragraph 2.1.1.4.3 where we concluded that within 5C, IoT could be assimilated to the CPS level and PLM could be considered as one of the components of the Decision Support System (DSS).

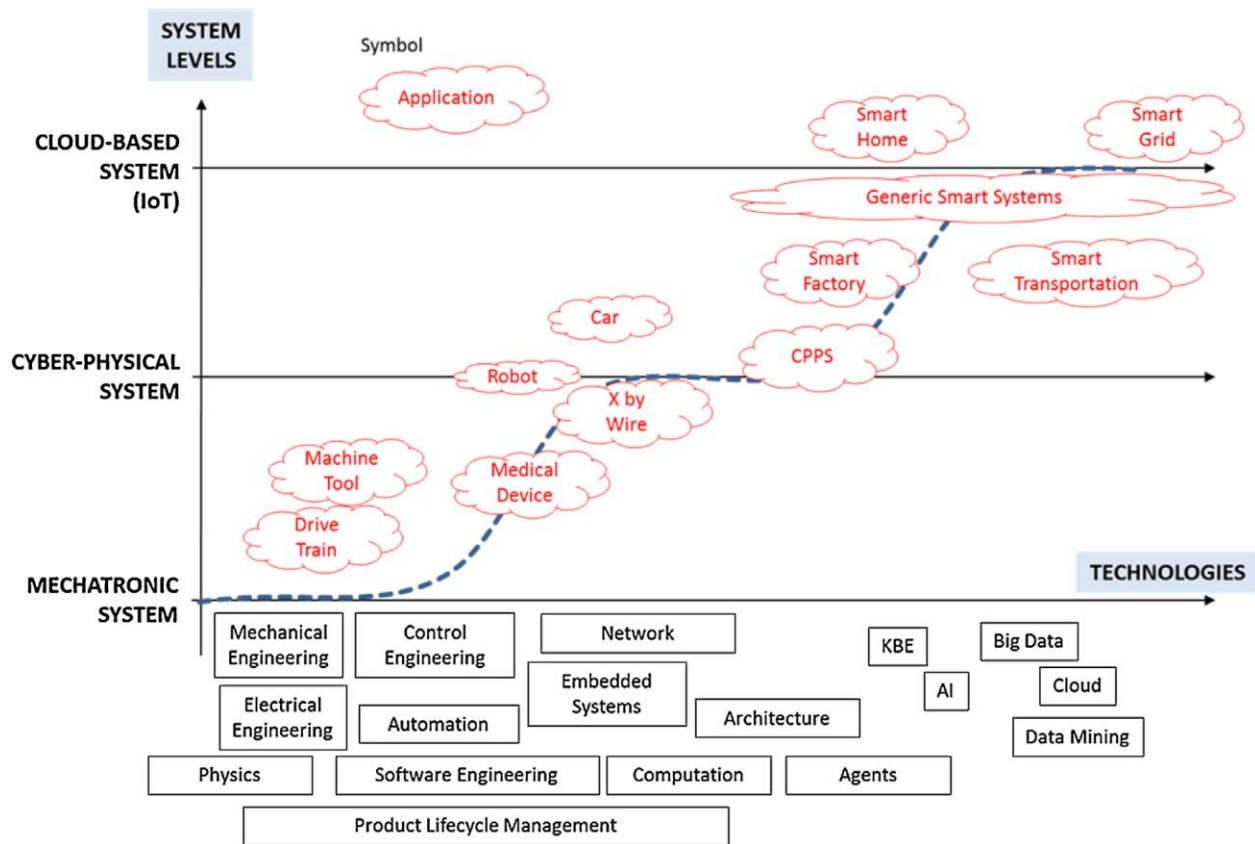

Figure 2-21. “Transition process from Mechatronics to CPS to Internet of Things.”, from (Hehenberger et al., 2016)

Finally, (Pivoto et al., 2021) does an exhaustive literature review of “Cyber-physical systems architectures for industrial internet of things applications in Industry 4.0”.

2.6 State of the art synthesis and scientific research question

The problem statement leading to this state of the art was:

How to link product lifecycle management information, especially engineering information, and data from connected objects, whatever they are, in a discrete manufacturing industry context?

Throughout this state-of-the-art review, we have demonstrated the current lacks in literature and established the necessary building blocks a framework proposition. We first demonstrated that they

are currently no existing methodology or enterprise model that takes care of the link in between PLM and IoT with an important level of detail. This therefore fuels the necessity of developing something outside of those borders even as it might get re-encompassed into a given model or architecture in time.

The study of the state of the art of PLM outlined its history, we focused on the fact that PLM's return on investment is overall admitted by vendors and practitioners while arguing that the literature backing that claim is still limited. Foreseeable current challenges for PLM were also identified before tackling the PLM software perspective and more particularly the PLM software's functionalities. Finally, that section ended by presenting some PLM features and concepts which will be reused in our framework proposition.

Then, the study of the state of the art of IoT focused on the IoT platforms, as IoT was addressed previously in the introduction. We outlined the foginess surrounding the structuration of the domain despite starting to have some differentiating selection criteria. Finally, the last section presented information structuration as a necessary component for our proposal.

A short section summarizing the author's works on joint literature on PLM and IoT demonstrated that the interest in the domain is growing upon academia but that no prior work took the perspective of the existing information systems as well as a global approach to IoT and the product's lifecycle management. To make those two systems work together and connect, we then exposed the concept of interoperability, and we noticed that federated interoperability with ontologies was far from being an industry-ready solution. Also, we exposed the authors' publications on PLM migration to justify why thinking about a combined common PLM/IoT software is not a feasible option to address the research questions. Finally, the buzzword Digital Twin and CPS were dug out and existing definitions were exposed as there is no consensus existing to date.

Overall, this state-of-the-art chapter demonstrated the lack of architecture ensuring interoperability between PLM and IoT and paved the way for such a proposal being a building block for a Digital Twin.

From this state of the art, we therefore formulate the following scientific research question:

RQ: What framework could be used to produce an industry-ready solution to ensure a digital thread between PLM and IoT Information systems?

We will answer this scientific research question in two parts:

- Chapter 3 will outline the methodological framework that will be used to ensure the digital thread between PLM and IoT. This will rely on the four concepts outlined in this chapter as well as three novel approaches.
- Chapter 4 will address the “industry-ready solution” part of the question as we will outline the gap between our methodological framework and the current enterprise solution. Based on the outlined literature, we will choose an IT PLM and an IoT platform before detailing how the novel approaches could be easily implemented in such enterprise solutions.

After that, Chapter 5 will demonstrate the validation of the methodological framework on a use-case: the REBO smart bottle.

CHAPTER 3 PROPOSITION

A method is “a particular procedure for accomplishing or approaching something, especially a systematic or established one”.²⁶

A framework is “a basic structure underlying a system, concept, or text”.²⁷

Nevertheless, no strong consensus among literature exists about what a methodological framework is (McMeekin et al., 2020). However, (Global Igi, 2019) defines it as an “approach for making explicit and structuring how a given task is performed” or as a “set of structured principles”. This is the definition we will rely upon when talking about a methodological framework. What we present is a set of principals explaining how a given task, creating a digital thread between PLM and IoT, is to be performed. When relating this perspective to interoperability, we aim to be a helper to address integration or a key input for building a central pivot model to ensure unification.

This chapter will go through the methodological framework: based on foundations described in the state of the art, we will add a building consisting of three novel approaches to shape a robust aggregate and ensure a digital thread between PLM and IoT. We will start out by laying the foundation: the four key concepts previously described (Baseline, Change Management, Product Instantiation and IoT information structuration). Then we detail the three novel approaches one by one: function-enabled PLM, problem report as a medium and enrichment of ‘As to be’ baselines. We will end by outlining the verification criteria to assess the proposition and by explaining the associated validation criteria.

In the following chapter, we will demonstrate the technical feasibility of the proposition using a combination of a PLM software: Windchill and an IoT platform: ThingWorx.

²⁶ Definition from Oxford Languages, <https://www.google.com/search?q=method+definition>, last accessed on August 6, 2021

²⁷ *Idem*, <https://www.google.com/search?q=framework+definition>, last accessed on August 6, 2021

3.1 Four key concepts from PLM and IoT

The four key concepts which we use as the foundation of our proposition have been described in section 2.2.3 (p.47) as well as in section 2.3.3 (p.62). Therefore, this section will only position them with respect to each other without extending too much about them. In three following sections section, we will be moving on to the three novel approaches.

3.1.1 Four key concepts and their respective positioning

3.1.1.1 Concepts from PLM and their positioning

The three PLM concepts have been previously described in section 2.2.3, we shall throughout this paragraph see how Baseline, Change Management and Product Instantiation are represented then how we represent them altogether.

3.1.1.1.1 *Baseline*

Following 2.2.3.1 Defining Baseline, we represent the various baselines as a succession within a PLM system. The descending link between the different baseline items is not represented in Figure [31] for clarity's sake although underlying. However, both "As built" and "As maintained" baselines are represented as superseding their "formally approved configuration" baselines to represent the misalignment between the product's reality and its theory. We shall see throughout the proposal how linking PLM and IoT could bring them to a potential realignment.

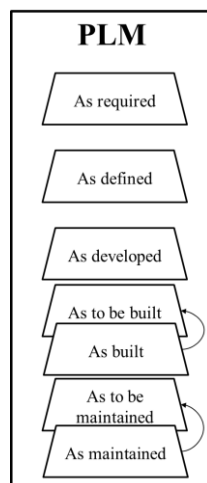

Figure 3-1. Representation of configuration baseline

3.1.1.1.2 Change Management

Given the importance of the first and last step in our proposition compared to the rest of the components, we decided to represent change management (also known as engineering change process), as done in Figure 3-2 below. For sake of clarity, the steps in between are simply represented as “the change process”.

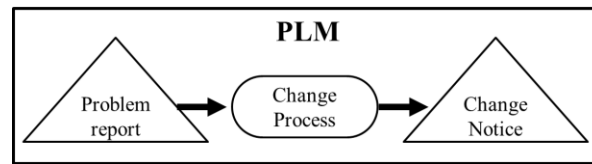

Figure 3-2. Representation of change management

3.1.1.1.3 Product Instantiation

Product instantiation’s importance was outlined as important by the author in (Barrios et al., 2019b):

“In the target architecture, product instantiation (and therefore sensor initiation) shall be supported via another ICT based system rather than the PLM or IoT systems but shall make this information available for both systems (PLM and IoT).”

Despite the notion of product instantiation being core to PLM itself, product instantiation is neither covered by IT PLM nor by IoT platforms. IT PLM has information concerning the product, while IoT platforms contain data about the product instances. The links between the product and its instances are managed neither by PLM nor by IoT. Currently, existing product instantiation systems such as ERP or more specifically one of its modules, establish, within the information system, the link between the product and its instances. Therefore, we noted “[In necessary cases]” in Figure 3-3 below to represent the possible presence of this intermediary instantiation system. In our proposition, we represent the instantiation process as an abstraction of the link between the PLM and IoT components.

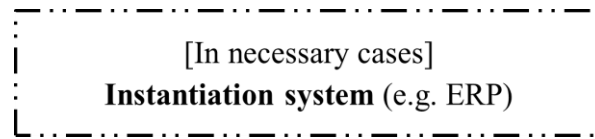

Figure 3-3. Representation of product instantiation

3.1.1.1.4 Representing the PLM concepts

The three concepts from PLM are therefore represented as depicted in Figure 3-4 below. Change management has been flipped for graphic purposes but its meaning remains unchanged.

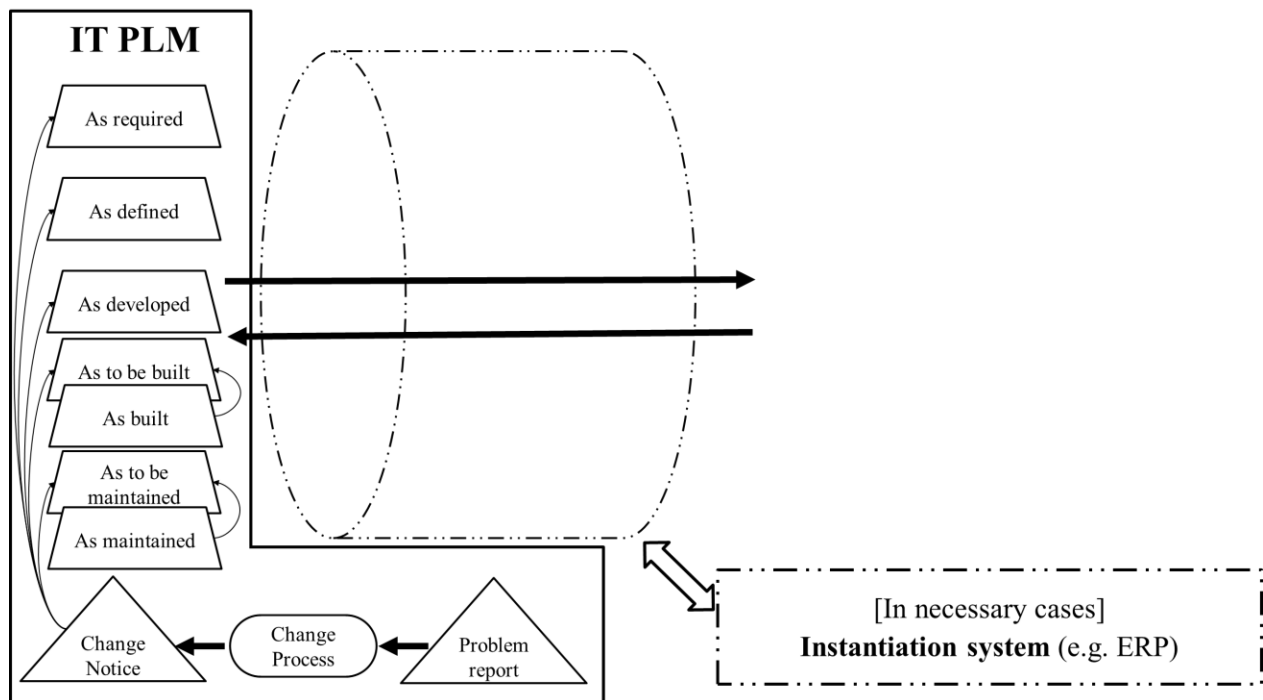

Figure 3-4. Representation of all three PLM concepts

3.1.1.2 The fourth key feature of the proposition: IoT Information Structuration

As underlined in Section 2.3.3, IoT's definition has evolved from RFID in the past, to a sensor now and should evolve to an actuator tomorrow. The implementation of IoT artefacts shall be loose and robust enough to be able to address a fluctuating IoT definition. Indeed, IoT platforms will undoubtedly evolve to tackle the emerging share of actuating device, but the link to the PLM systems will necessarily have to evolve along with them. In addition to the three categories, we

shall add another “holdall” one which will encompass for instance user feedback, external data collection or any item that would not fall to the three previous categories. We therefore categorized IoT platforms’ data as being product identification, sensor data, actuator details, or other. This is represented in Figure 3-5 below.

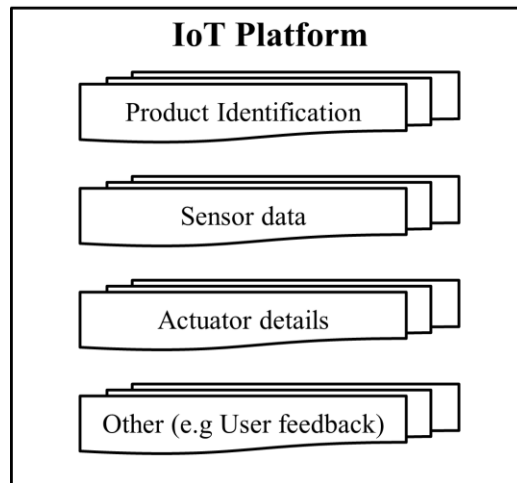

Figure 3-5. Representation of IoT Information Structuration

3.1.2 Concepts' Structuration

Overall, the four key concepts of Baseline, Change Management, Product Instantiation, and IoT Information Structuring represent the existing foundations upon which we will introduce three novel approaches in order to bridge the gap between PLM and IoT and therefore ensure an effective digital thread.

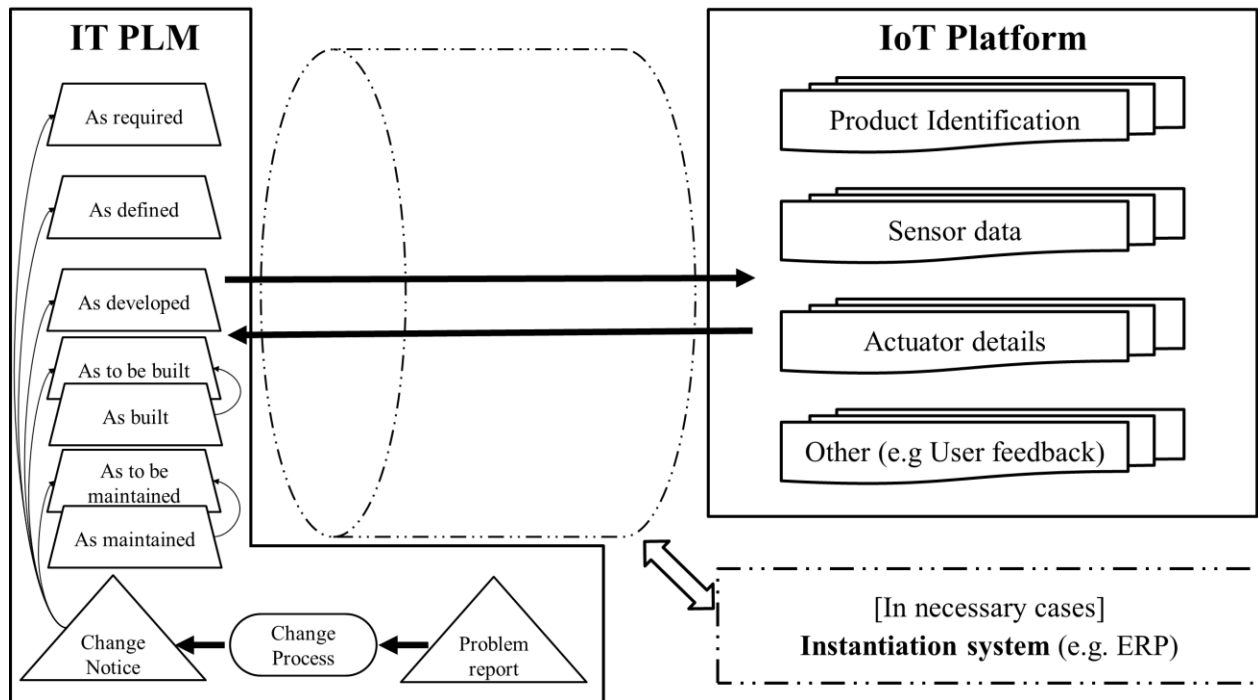

Figure 3-6. Representation of all four PLM and IoT concepts

3.2 [First novel approach: A] Function-enabled PLM

Current IT PLMs are component-centred, meaning that the components are the ones carrying the main information and therefore the product data and metadata are attached to it — Vendor solutions are often referred to as being either CAD-centric or document-centric. — Our proposition is to add three functions that embrace the full chain of components from the top parts to the more detailed ones. Those four functions: reacting, interfacing, storing, and data processing, all relate to a more data-oriented approach. Indeed, components of the products are the ones which are going to be playing those respective functions, but these functions are achieved for the count of a sub-part of the product or the whole product. For instance, a Bluetooth chip is going to be the component ensuring the communication interface, but the Bluetooth communication is a feature of the whole product and needs to be acknowledged at a higher level.

We will detail the four functions before moving on to detail their implementation throughout the first baselines of a product: As required, As defined and As developed.

3.2.1 The four functions

Data's journey starts with its collection. It is then stored, processed or even both. Also, it is interfaced for one (man or machine) to be able to access it. Finally, it might be used to trigger an actuator. Those different steps are the functions we deem necessary to express in a common way to link PLM and IoT: reacting, interfacing, storing, and data processing.

3.2.1.1 Reacting (sense/act) function

Reacting function is composed of both the sensing and the acting possibilities of IoT as well as identifying via tags and identification methods. Sensing is reacting to outside world stimuli, whereas acting is the outside world reacting to the stimuli. The way these interactions are done need to be described based on the resource type (tag, sensor, or actuator) performing the reacting function, and its associated parameters (range of use, gain, non-linearity, digital step, etc).

The tag function can be achieved through a dedicated tag, such as NFC or RFID, or through a component's unique ID, such as MAC address. As the sensor or actuator function can be achieved using existing descriptors or an available sensor ontology such as SSN/SOSA sensor ontology (Janowicz et al., 2019), we shall not dive into further detail here.

The associated parameters depend on the nature of the sensor and will enable one to use them as reference values and ranges in the processing function.

3.2.1.2 Interfacing function

The interfacing function expresses overall how information flows. It is enabled by either a human-machine interface or a machine-to-machine communication interface. Human interface is described based on different interactions: audio, visual, haptic, etc. Machine-to-machine interface specifies the means of communication in terms of used protocol and type. In the case of machine-to-machine interfaces, the function is to be specified on each side of the interface.

We shall not dive here into the massive number of devices and protocols that enable interfaces. One must however keep in mind that choosing a communication protocol is the result of a compromise between cost, distance, data transfer speed, energy consumption, quality of service, the necessary frequency of data transfer as well as the given protocol's ecosystem.

3.2.1.3 Storing function

The storing function expresses the capability of storing data: a certain quantity with a certain performance level for instance. This includes on-device storage as well as cloud storage, ranging from data stored in gateways and to intermediate devices such as smartphones. Storing function specification includes the quantity of data, speed of storage and retrieving, storage reliability, and storage location.

Storing the data on edge is necessary for most IoT use cases, but the key to that is the agility. Connectivity from a remote sensor to the cloud requires a proper architecture design to make sure all intermediate gateways have the necessary information stored for their own processing strategies. For instance, an alarm middleware, such as a cold room temperature aggregator, might require having the past day's data in order to raise an alarm in case of deviation.

3.2.1.4 Data Processing function

The data processing function expresses the capability of doing some calculations or reasoning on the data itself. The parameters include the type of equipment (MCU, CPU, GPU, etc.), calculation power, and precision if necessary. The data processing function will enable, based also on the react parameters, business logic on items such as nominal values, tolerance range, operating range, alert threshold, or alarm threshold.

The ability to choose a processing side between server and on-edge is increasingly common as more low-cost sensors and devices emerge. Processing the data on edge might be end up faster, secure by design than cloud-processing. However, it can be difficult to put in place, to manage and to migrate hence making it sometimes much more expensive.

Reacting	Interfacing
Storing	Data Processing

Figure 3-7. The four functions necessary to implement in products

This product description through functions is then going to be re-used in the integration of IT PLM with IoT platforms to express the product or the sub-product's capability from an IoT point of view. Therefore, the distinct items common to PLM and IoT will have an existence both in the PLM

baseline but also in the dynamic IoT Platform. We outline the necessary inputs of the PLM baselines into the IoT platform throughout the product's development.

3.2.2 A1: As Required: Describe Product's capabilities (including sensing)

Part of the As Required baseline needs to describe a product's capabilities from a system engineering standpoint. All the details will not be available during requirement phase, but the baseline requirements must clearly describe what data is expected to be collected, and where it is expected to be exposed in the respective interfaces. Therefore, the react and interface functions will usually be included in first draft of the product, while the store and process ones will only be detailed in later phases. Depending on the complexity of the product, it will most likely be decomposed in sub-product and each of them will decompose the four functions at their level to answer the relevant use-cases.

For instance, if creating a wireless sound system: the interface will describe where the user will input the music choice while the react will describe where the sound will be emitted. Store and process are not defined at first but then will come based on the other relevant inputs.

3.2.3 A2: As Defined: Function-based description of capabilities: {React, Interface, Store, Process}

The As Defined baseline needs to describe the fleshing out of the requirements in an actual product. Sensors and interfaces are gradually defined and will follow the Store and Process capabilities. The raw Bill of Materials (BOM) will start to include the various sub-products & components that will hold the functions' roots.

Internal interfaces might not necessarily be communicated to the IoT Platform.

3.2.4 A3: As Developed: Component carrying the {Reacting, Interfacing, Storing, Data Processing} function

As Developed baseline will see the BOM fully filled in. The components will have been fully defined and the React components chosen. At this point in time, each function is distributed at the lowest level possible across the components and the implementation in both the PLM and IoT

Platform is fully delivered and ready for product instantiation and feedback loop. With a product's variant and options, the various functions should carry similar behaviours in order to enable the generalisation of collected data in the use phase of the product.

3.2.5 Further baselines: minor changes

3.2.5.1 As to be Built: mainly deviations

The As to be Built baseline might experience a few deviations when instantiating the product depending on the availability of components (electronic mainly).

3.2.5.2 As to be Maintained: possible improvements following version upgrade

The As to be Maintained might proceed to some interchangeability between components. However, these will still hold to the same functions developed with the product. In a service-oriented business model, the As to be Maintained baseline might see the functions being densified by improving a product's React function or enriching the associated Interfaces to provide more third-party integrations. These enhancements are represented as component A1 to A3 in Figure 3-8 below.

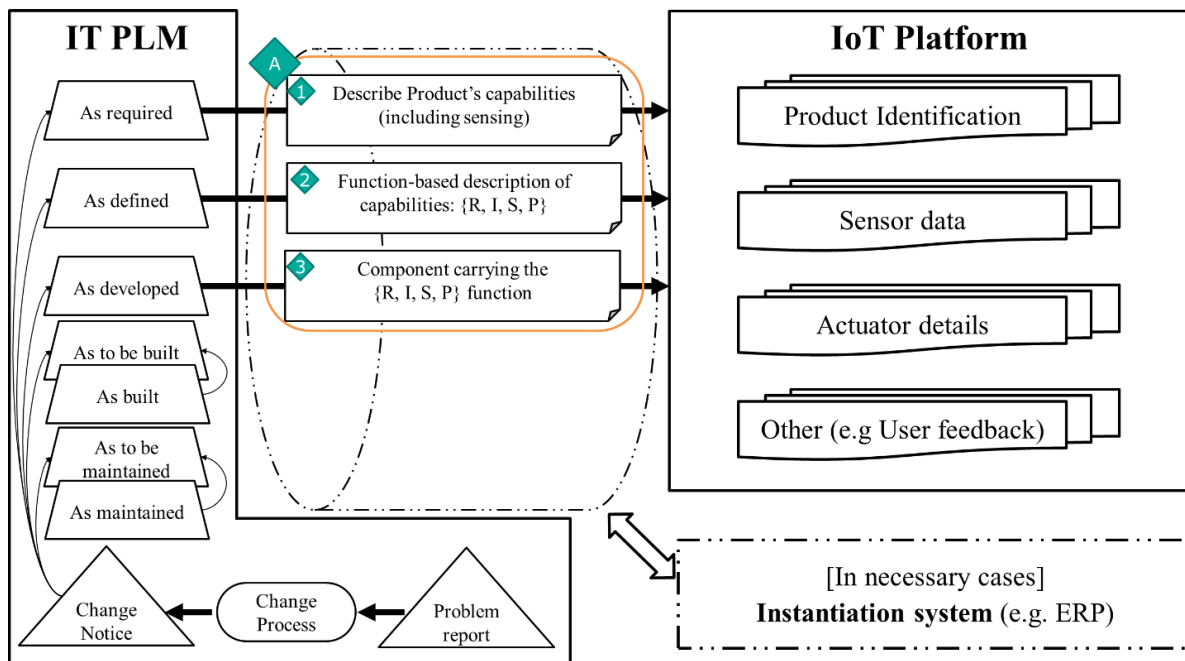

Figure 3-8. Adding function-enabled components (A1, A2, A3) to the framework

3.3 [2nd Novel Approach: B] Problem report (and change management) as a medium

Current implementation of change management within the IT PLM context remains the same. Our proposal focuses on adding this to the IoT. In an IoT context, product's specification has been inputted in the IoT platform as mentioned previously and the part or subproduct is easily identified through a combination of the instantiation system and the 'As Developed' baseline. The IoT platform will therefore be able to automatically create a problem report (PR) in the PLM system whenever recorded values are out of range or tolerance.

The recorded values will be identified in the problem report and sent to the IT PLM for analysis. Corrective mitigation measure (such as tweaking the parameters) could be added while the issue is further investigated. This limits the need for manual intervention, as most of the defects will be automatically reported directly from the devices through the IoT platform to the PLM system. Problem report as a medium significantly reduces the time required to diagnose problems when incidents are detected and analysed in the PLM system.

Also, Problem report as a medium leads to a more localised fault research as the problem report will contain information specifying which function, sub-product or component is failing

Despite the prognosis being of a more technical nature than human intervention, human intervention and expertise is sometimes still required. The product report could also be enriched with some user data. For instance, the product might have failed and therefore asks the user some feedback via one of its interfaces. It could also be the user who is starting a problem report and then the IoT Platform will automatically enrich the problem report with the relevant data at the time of the user's feedback. This enhancement is represented as component B in Figure 3-9 below.

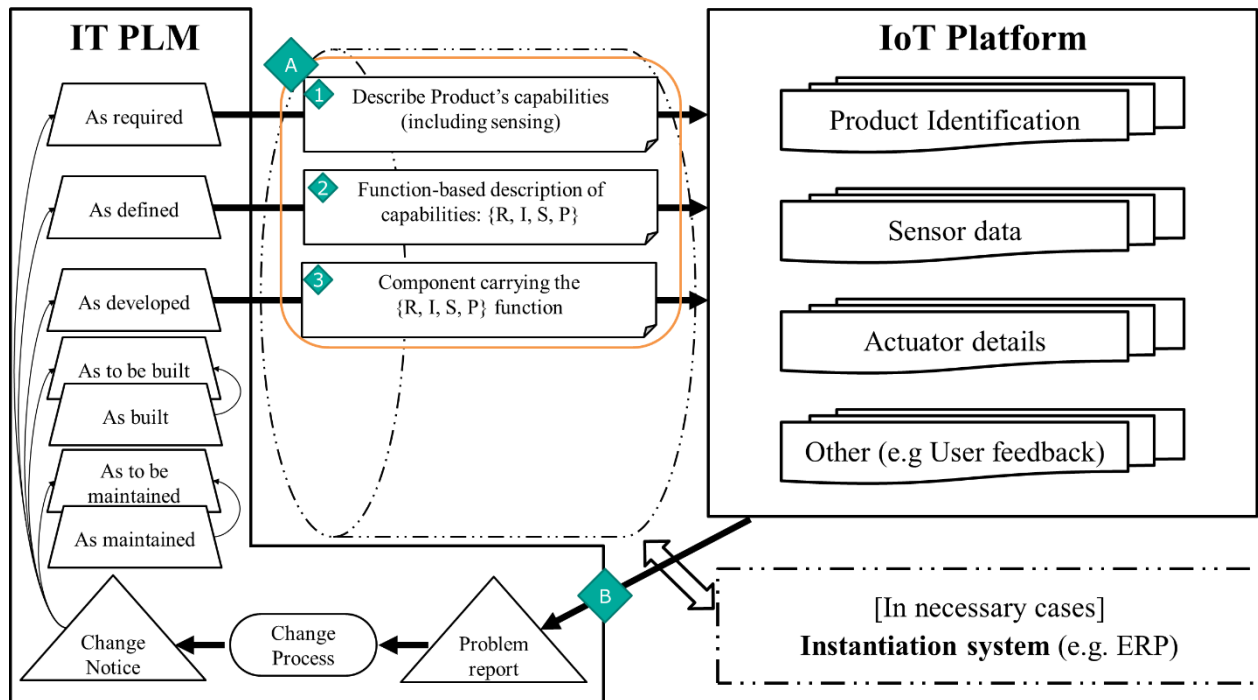

Figure 3-9. Adding Problem Report feedback loop (B) to the framework

3.4 [3rd Novel Approach: C] Enrichment of 'As to be' baselines

The 'As to be' baselines, namely the 'As to be Built' and 'As to be Maintained' baselines, are sometimes named wrongly as the 'As Built' or 'As Maintained' as they are the set of guidelines created by the engineering teams on how the product should be built or maintained and not how it is. Having a clear digital representation of a product at a given stage is key to ensure correct behaviour and plan for the adequate maintenance plan, it's therefore important to store the 'As Built' and 'As Maintained' baselines (and not just the 'As to be Built' and 'As to be Maintained'). Nowadays, only a few industries, in majority Aerospace and Defense sector, store the 'As Built' baseline in their PLM. To remedy this and store the 'As Built' and 'As Maintained', the integration between PLM and IoT is of significant help: the IoT platform will return the various usage information of a product back to the PLM and the baselines can be adjusted to the product's actual state. Moreover, by having the product's operating behaviour, engineers will be able to refine the definition of the range and tolerances, therefore leading to better maintenance and failure analysis of the products.

By providing more data to the PLM via this feedback loop, engineers will be able to react accordingly to potential problems and provide proper remedial actions in order to ensure that the As Built remains as close as possible to what was defined in the As to be Built baseline, by being able to fine-tune the manufacturing process. This enhancement is represented as component in Figure 3-10 below.

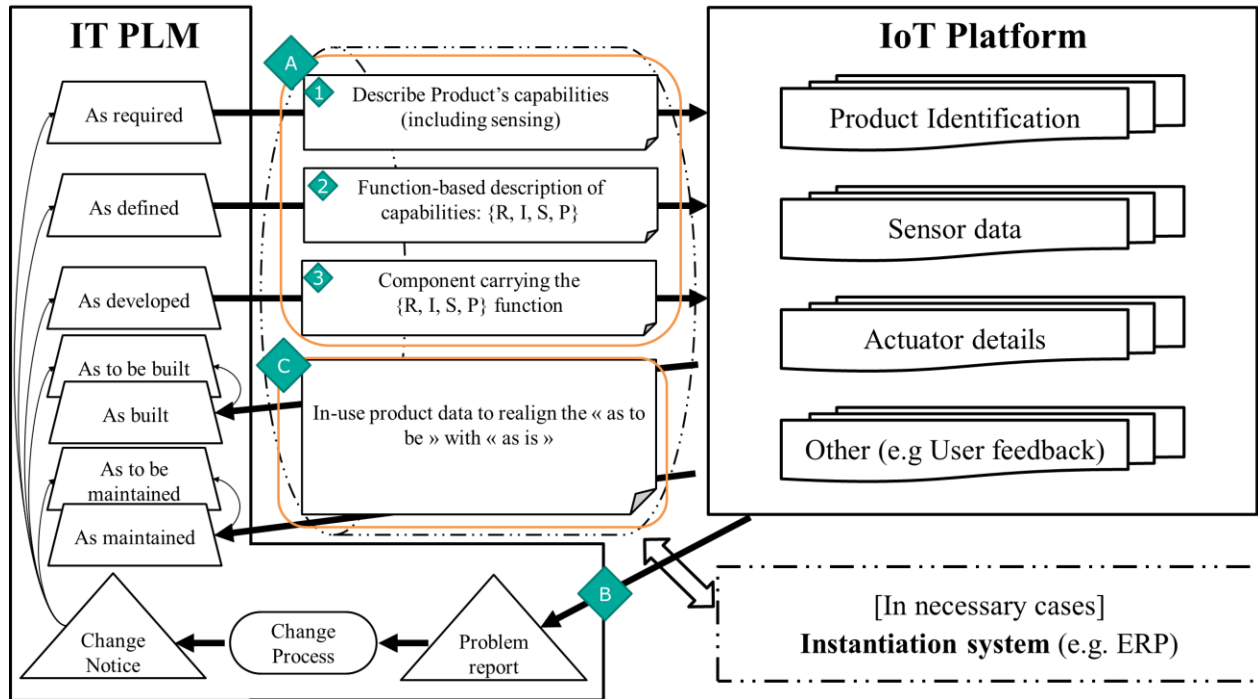

Figure 3-10. Adding Enrichment of 'As to be' baselines (C) to the framework

3.5 Verification and Validation criteria

This section will tackle the different criteria need to check relevance of proposition. The research question's answering is tackled through the verification criteria while the problem statement answering is done through the validation criteria.

3.5.1 Verification criteria

Verification criteria are defined to ensure that work products meet their design input requirements. In our context, we want to make sure the research question is answered by our proposition:

What framework could be used to produce an industry-ready solution to ensure a digital thread between PLM and IoT Information systems?

We therefore need to verify that:

- We are proposing an industry-ready solution:
 - o This could be either achieved by developing from scratch a solution OR
 - o Using existing solutions and tweaking them to fit the proposition.
- The solution is using the proposed framework.
- We are indeed connecting PLM and IoT information systems.

As we described throughout state of the art, attempting to develop an ad-hoc is definitely not recommended even if at all feasible. Nevertheless, this would pass the outlined verification criteria hence the necessity of listing it here.

3.5.2 Validation criteria

Validation criteria confirm that requirements meet the stakeholder needs and intended uses. We shall here outline a few criteria one could use to assess the impact of such an implementation. First off, one would need to document existing scenarios where PLM and IoT data are needed jointly for product development, industrialisation, or maintenance. Then those scenarios would need to be addressed with our proposition to see if we are addressing the problem statement:

How to link product lifecycle management information, especially engineering information, and data from connected objects, whatever they are, in a discrete manufacturing industry context?

To verify our proposition, we shall therefore check that:

- We are in a “discrete manufacturing industry context”;
- We have product lifecycle management information;
- That part of this is engineering information.
- We have data from connected objects;
- Those data are of various nature

- Both the PLM information and the IoT data are linked.
 - o Do we have the relevant PLM information in IoT?
 - o Do we have the relevant IoT information in PLM?

Overall, verification and validation are key in ensuring the effectiveness of the proposed methodological framework. These criteria will ensure the alignment of the proposition with the scientific research questions. We shall summon those criteria again respectively at the end of Chapter 4 for verification and at the end of Chapter 5 for the validation.

3.6 Synthesis and proposition wrap-up

Throughout this Chapter, we have outlined the proposition of this thesis, namely a methodological framework for a digital thread between PLM and IoT. We started off by positioning the four existing blocks: Baseline, Change Management, Product Instantiation, and IoT Information Structuring. We then added three novel approaches: Function-enabled PLM (based on reacting, interfacing, storing and data processing functions), Problem report as a medium, and Enrichment of 'As to be' baselines. Finally, we touched base on verification and validation criteria in regard to the scientific research question and the initial problem statement. Next Chapter will focus on demonstrating the industrial readiness of the proposed methodological framework.

CHAPTER 4 INDUSTRIAL READINESS OF METHODOLOGICAL FRAMEWORK

Throughout this chapter, we will first demonstrate the feasibility of the proposition's implementation with some Industry used PLM software and IoT platform before moving on to verify that the implementation indeed passes the verification criteria.

4.1 Implementation guideline

As outlined in the state of the art, there often is a gap between the concepts and what the ICT systems are doing or ready to do. Therefore, we shall attempt to demonstrate in this section how to implement these proposals into an ICT system either with existing artefacts or what should be done to make things work.

Before diving further, we need to detail the bill of material used by practitioners to establish how functionalities are implemented or implementable in an enterprise software system: COTS/OOTB, configuration and customization. Commercial off-the-shelf (COTS) and out-of-the-box (OOTB) are two terms used to describe features that are in the product and that work immediately without any configuration or customisation. Configuration refers to features that are available to the client through a minor effort through either initial parameter selection upon installation, an admin panel or user parameters. Customization is however a major effort as the software is going to be extended with new features that must be defined, developed, and tested before being rolled out. Concerning what is best for an industry, they might be a circular trend in-between no-customisation and fit-to-industry; it is pointed out by (Madjar, 2017) for PLM but can be generalized to any enterprise software system. Fitting to a given tool induces a change in the processes whereas using too much customisation leads to a difficulty in maintenance and upgrade.

4.1.1 Choice of platforms

For any practitioner, choosing a platform is always a struggle as it is the reflection in between a compromise between cost, quality, and time. From our academia standpoint, choosing a platform over the other could lead to some biases as some features are available in some platform but not in others. Here, we outline why we choose Windchill as the IT PLM system and ThingWorx as the IoT platform.

4.1.1.1 Windchill as the PLM software

As outlined previously in “2.2.2.1 PLM software functionalities studies”, PLM functionalities despite being different, remain quite consistent from one PLM to the next. In the comparison established by (Enríquez et al., 2019) and from practitioners’ experience, PTC’s Windchill is well suited to attempt to demonstrate the different propositions. Indeed, as will be demonstrated through the following, Windchill can be parametrized or even customized to reflect the needs of an industrial or any client.

“PTC Windchill Customization Guide” (PTC, 2015) describes configuration from Windchill’s standpoint as being either properties (requires server restart) or preferences (does not require server restart). Moreover, Windchill provides a ‘soft typing’ process which allows to extend existing types and meta data attributes without resorting to customization, please refer to Figure 4-1 below for examples. On the other side, customization is that of the data models, service, user interface, Info*Engine, or reports.

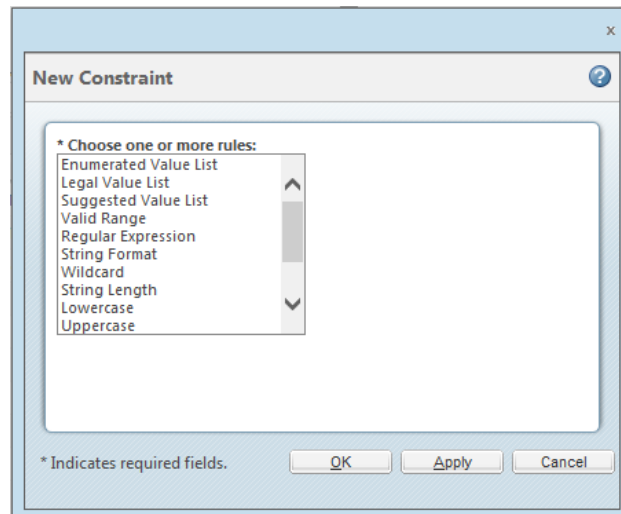

Figure 4-1. List of constraints than can be applied on soft attributes (Windchill screenshot)

4.1.1.2 ThingWorx as the IoT platform

As outlined in “2.3 IoT and IoT Platforms”, choosing an IoT platform is not an easy task as the field is in constant evolution. ThingWorx was picked as it was best ranked by the author in (Santana et al., 2021) and that it is part of (Hoffmann et al., 2018)’s top ten IoT platforms. Moreover, it is a recognized IoT platform among practitioners.

Overall, IoT Platforms as they are currently maturing are still closer to an overall toolbox rather than a structured-by-default information system such as a PLM or an ERP might be. Therefore, most implementation of the proposition will happen to be configuration rather than customizations. However, those configurations are often trickier than the ones we would have on the PLM side.

Recently, PTC has released ThingWorx Flow²⁸. It is a flow-based programming tool which is integrated with the various PTC solutions as well as external providers. Depending on the future released programming bricks and given the ease of use of the first ones, this might become a preferred solution to customisation in the future.

4.1.2 Interaction mode

Given the popularity of the technology and its availability in Windchill, we shall choose to use REST API OData in order to link IT PLM and IoT Platform. (API stands for application programming interface, REST stands for representational state transfer while OData is short for Open Data Protocol.) It is a standard architecture which is used to create web services. Therefore, we shall send requests towards Windchill in order to gather information and make changes about a given product. Figure 4-2 below illustrates the architecture choice.

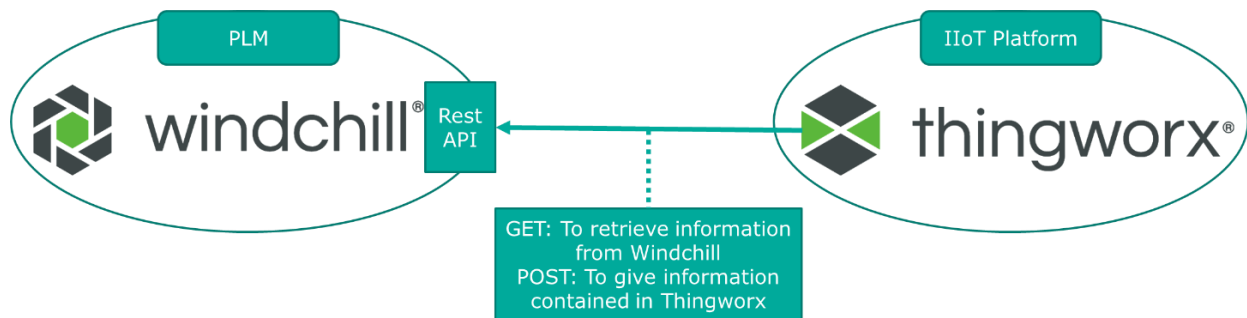

Figure 4-2. Demonstrator architecture outline between Windchill and ThingWorx

²⁸[http://support.ptc.com/help/thingworx_hc/thingworx_8_hc/fr/index.html#page/ThingWorx/Help/Integration Orchestration/ThingWorxFlow.html](http://support.ptc.com/help/thingworx_hc/thingworx_8_hc/fr/index.html#page/ThingWorx/Help/Integration%20Orchestration/ThingWorxFlow.html), last accessed October 22nd

4.1.2.1 GET requests

GET method is officially described by (Fielding & Reschke, 2014) as a “Transfer a current representation of the target resource.” It enables one to gather information from Windchill to have it in each context; in our case, the IoT platform. For instance, the following request returns the BOM structure of an assembly as shown in Figure 4-3 below: GET <URL_Windchill>/Windchill/servlet/WindchillAuthGW/com.pxz.visu.vsxml.VSXMLExport/getBOM?number=<oid>

4.1.2.2 POST requests

POST method is officially described by (Fielding & Reschke, 2014) as a “Perform resource-specific processing on the request payload.” It enables one to send information to Windchill from an external context; in our case, the IoT platform.

```

}, {
  "CustomId": "OR:wt.part.WTPartMaster:374811/wt.part.WTPartUsageLink/0/null/OR:wt.part.WTPartMaster:373967",
  "Type": "ProductOccurrence",
  "Name": "0000026879",
  "Transformation": "0.0 -0.9455185755993168 -0.325568154457157 0.0 0.0 -0.325568154457157 0.9455185755993168 0.0 -1.0 0.0 0.0 0.0 -67.48117179908943 708.1987488347072 19.046209278120756 1.0",
  "Attribute": [
    {
      "Key": "Oid",
      "Value": "OR:wt.part.WTPart:375219"
    },
    {
      "Key": "PVID",
      "Value": "/0:426209-373967-ab3a5cd3-1f14-45e5-a07a-38607469262e"
    },
    {
      "Key": "DisplayIdentity",
      "Value": "0000026879, module_fourche_roue_avant.asm, 1.4 (Design)"
    },
    {
      "Key": "Name",
      "Value": "module_fourche_roue_avant.asm"
    },
    {
      "Key": "Container",
      "Value": "Demo Organization"
    },
    {
      "Key": "Version",
      "Value": "1 (Design)"
    },
    {
      "Key": "Quantity",
      "Value": "1.0"
    },
    {
      "Key": "OccurrenceName"
    }
  ],
  "Representations": [
    {
      "FileName": "module_fourche_roue_avant_high.obj",
      "URL": "http://dtm-inno-gfi.francecentral.cloudapp.azure.com:8080/Windchill/servlet/WindchillAuthGW/com.ptc.wvs.server.util.WVSContentHelper/redirectDownload/module_fourche_roue_avant_high.obj"
    },
    {
      "FileName": "module_fourche_roue_avant_low.obj",
      "URL": "http://dtm-inno-gfi.francecentral.cloudapp.azure.com:8080/Windchill/servlet/WindchillAuthGW/com.ptc.wvs.server.util.WVSContentHelper/redirectDownload/module_fourche_roue_avant_low.obj"
    },
    {
      "FileName": "module_fourche_roue_avant_medium.obj",
      "URL": "http://dtm-inno-gfi.francecentral.cloudapp.azure.com:8080/Windchill/servlet/WindchillAuthGW/com.ptc.wvs.server.util.WVSContentHelper/redirectDownload/module_fourche_roue_avant_medium.obj"
    },
    {
      "FileName": "module_fourche_roue_avant_high.glb",
      "URL": "http://dtm-inno-gfi.francecentral.cloudapp.azure.com:8080/Windchill/servlet/WindchillAuthGW/com.ptc.wvs.server.util.WVSContentHelper/redirectDownload/module_fourche_roue_avant_high.glb"
    }
  ]
}

```

Figure 4-3. Windchill API response: a JSON containing information about the root assembly, subassemblies, and parts.

4.1.2.3 Windchill REST Services 1.6

Windchill REST Services 1.6 is the latest version available, its documentation is available online²⁹. It is a Windchill module that enable developers to configure OData services in Windchill. Since Windchill 11.0, the module is bundled (i.e., comes with) Windchill therefore easing the deployment on the more recent IT PLM. The REST Services has various Domain Capabilities for the various components of Windchill: Product Management Domain, Parts List Management Domain, Change Management Domain, etc. Relying on some of these to interact with Windchill is therefore going to be crucial in order to implement our proposition.

We also note that previously Windchill was relying on Swagger API in order to enable this feature, but this will gradually be deprecated in favour of the above OData services (personal communication).

4.1.3 Function-enabled PLM

Function-enabled PLM is tricky because we need to implement all four functions independently: reacting, interfacing, storing and data processing. Moreover, a component can hold more than one function as well as a function could be covered by multiple components. We however suggest implementation to limit this possibility as this will lead to extended edge effects. If a product has a temperature (sensing) function insured by two sensors, this should be broken up as two sensors as well as a processing unit that will do the intermediary calculation.

4.1.3.1 On the PLM side: Customization or add-on module

On the PLM side, function-enabled PLM could be done via soft-typing or subtypes (cf. is we wanted to have only this parameter at the component level, but we want to have it replicated all along the BOM tree, this will therefore require customization directly on the PLM software or via the use of an add-on module.

²⁹ https://support.ptc.com/help/windchill_rest_services/r1.6/en/, last accessed October 16th, 2022

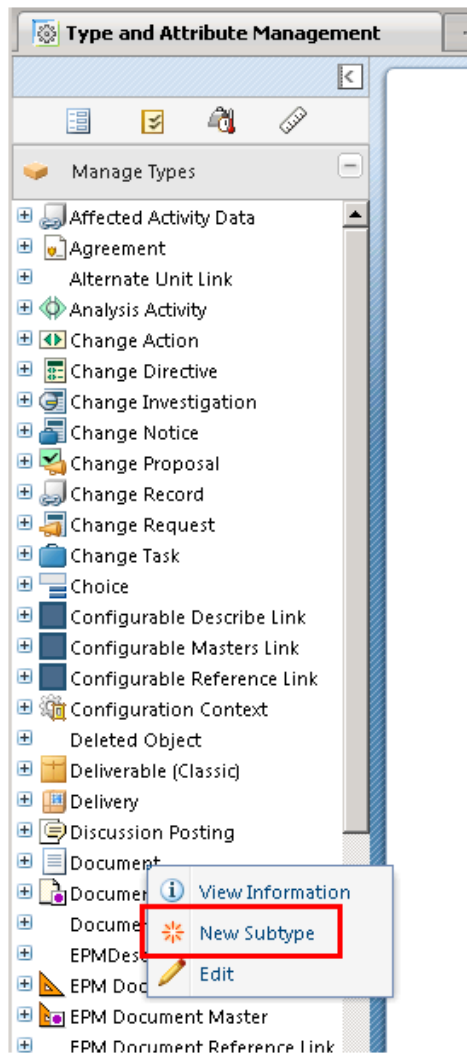

Figure 4-4. Type and Attribute Management Admin panel where subtypes can be created
(Windchill screenshot)

4.1.3.2 On the IoT side: Configuration in IoT Platform

If considering a new system, this approach could be implemented in ThingWorx via the use of Things Templates and/or Shapes. Moreover, the access to elements in Windchill could be done via

the use of the WindchillSwaggerConnector³⁰ which enables an out-of-the-box connection to the Swagger services or the ODataConnector³¹. The IoT platform will therefore need to be configured to adequately put in place the function-enabled PLM.

4.1.4 Problem report as a medium

Problem report is the most accessible concept to be implemented and we recommend starting by this one in an industrial scenario.

On the PLM software side, we are looking to an OOTB (Out of the Box) solution. Indeed, Problem reports are a fully out-of-the-box feature in Windchill³² and have a default workflow that enables the different steps of change management.

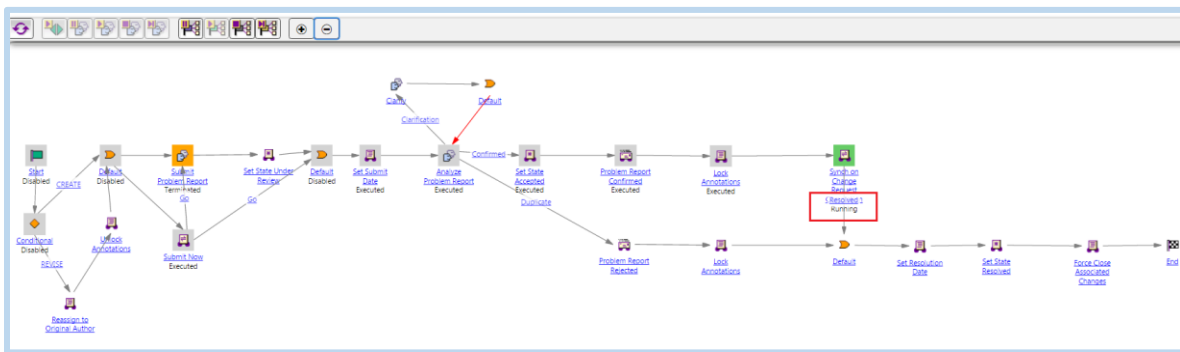

Figure 4-5. Windchill's internal problem report workflow

Also, Problem reports, have a dedicated domain in the Windchill REST Services³³.

³⁰<https://support.ptc.com/help/thingworx/platform/r9/en/index.html#page/ThingWorx/Help/Composer/IntegrationConnectors/ConnectorWindchillPrereqs.html#>, last accessed October 23rd, 2022

³¹<https://support.ptc.com/help/thingworx/platform/r9/en/index.html#page/ThingWorx/Help/Composer/IntegrationConnectors/ConnectorSAPODataPrereqs.html#>, last accessed October 23rd, 2022

³²https://support.ptc.com/help/windchill/whc/whc_en/index.html#page/Windchill_Help_Center%2FChgMgmtProblemReportAbout.html%23, last accessed October 16th, 2022

³³https://support.ptc.com/help/windchill_rest_services/r1.6/en/index.html#page/windchill_rest_services/changemgmtdomain.html, last accessed October 16th, 2022

On the IoT platform side, we have a mix of OOTB and customisation. Creating a problem report was something that needed to be entirely done in a custom way until ThingWorx 9.2 which introduced the feature OOTB³⁴. The feature is available (in ThingWorx Navigate) for all user groups which means that anyone with access to the system can issue a Problem Report (cf. Figure 4-6). However, triggering automated problem reports if the IoT in out of specified range will still have to be the result of a customisation.

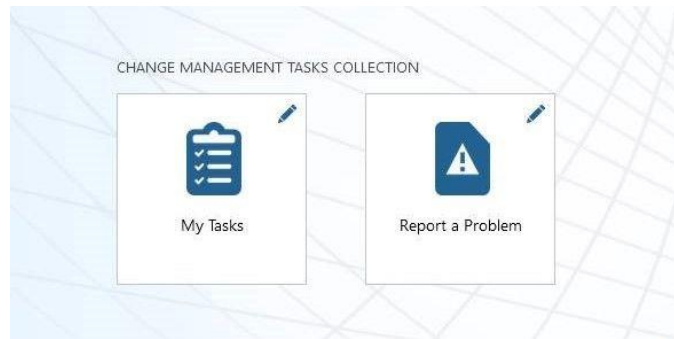

Figure 4-6. Illustration of new "Report a Problem" feature from ThingWorx 9.2 announcement³⁵

4.1.4.1 Enrichment of 'as to be' baselines

This implementation guideline assumes that the baselines are stored with Windchill. We do however acknowledge that only few enterprises have the both the MBOM and SBOM in PTC. Indeed, many would perceive this as having all their eggs in the same basket and want to avoid vendor lock-in.

4.1.4.2 On the PLM side: OOTB (Out of the Box) if via Change Request

This feature could be implemented at first via the Change Management workflows by directly plugging ThingWorx to Windchill at one of the steps described in subsection 2.2.3.2 Change Management. For instance, Windchill 11 enables handling directly Change Request, Change

³⁴ <https://www.ptc.com/en/blogs/corporate/introducing-thingworx-9-2>, last accessed October 16th, 2022

³⁵ <https://community.ptc.com/t5/ThingWorx-Navigate/ThingWorx-Navigate-9-2-Preview-quot-Report-a-Problem-quot-amp/td-p/734239>, last accessed October 16th, 2022

Notices, Change Investigations and Change Proposals. Therefore, depending on the maturity of the feedback from IoT, the enrichment of the baselines could happen at various levels.

4.1.4.3 Other possibilities on the PLM side

One could also imagine a customization where the baseline would be directly edited based on the IoT feedback. However, this would not accommodate most cases of feedback as well as require extensive specific development.

4.1.4.4 On the IoT side: Configuration in IoT Platform

Configuration similar to the one required for the function-enabled PLM would need to be put in place.

Throughout this subsection, we unrolled the implementation guideline of the methodological framework for two given enterprise software: Windchill and ThingWorx. These have their advantages and drawback but nevertheless, this demonstrates the necessary extra work that one would need to put in place the proposition.

4.2 On the effort to implement

Despite having listed here numerous links and existing components that are already existing and ready to be used to implement the proposition, the remaining effort is huge given the sheer complexity of respective software. Indeed, one must keep in mind that both Windchill and ThingWorx are enterprise solutions therefore requiring decently sized servers in order to install these. Moreover, putting in place some elements will require some extensive configuration and tricky customisations to the existing data model. Finally, some of the elements of solutions provided here are available on a given version while some others are available on a later one. This will require expert knowledge of each system in order to ensure the adequate implementation.

In the industry, these solutions tend to be configured, customised, and tailored to fit the various business needs (as well as satisfying some stakeholders' desires) to ensure the efficiency of the PLM or IoT software in the company environment. This extra layer of complexity is to be closely overseen as this could impact ability to deliver on the implementation of the methodological framework.

Nonetheless, the methodological framework on how to link PLM and IoT has been made explicit and we proved that this framework was industry-ready with some tweaking to existing IT PLM Windchill and IoT Platform ThingWorx. Hopefully, solution vendors will ease the access to this or even make it freely available out-of-the-box in the future software versions.

4.3 Verification

On the verification side of things, we need to reflect upon the criteria outlined in the previous Chapter:

- The solution is using the proposed framework;
- We are proposing an industry-ready solutions:
 - o This could be either achieved by developing from scratch a solution OR;
 - o Using existing solutions and tweaking them to fit the proposition.
- We are indeed connecting PLM software and IoT platform.

In the given implementation guideline, the proposed implementation is indeed using the methodological framework as well as proposing an industry-ready solutions using existing solutions and tweaking them to fit the proposition. And we are indeed connecting PLM system and IoT platform in order to ensure a consistent digital thread. Therefore, the solution is verified, and we can move on to the validation.

CHAPTER 5 VALIDATION ON A CASE STUDY

Proposing a relevant validation of the proposition could be done on part of a fairly complex industrial system. However, we aim to make it easily understandable by the reader and provide sufficient artefacts to illustrate the proposal. We shall validate our proposition with a smart connected product that was industrialised by the author.

This chapter will first present the context of the case study on a global scale as well as addressing the different baselines. Then use cases using the proposed methodological framework will be presented. Finally, we will assess the validation of the proposition through the validation criteria outlined previously.

5.1 Presentation of the case-study: REBO Smart Bottle

The REBO is a smart bottle that measures water intake and plastic saving as you are using it. The REBO uses Bluetooth technology embedded in its cap to track the amount of water consumed. A personalized hydration app (iOS and Android) syncs with the REBO bottle's smart cap to track health goals. The bottle lights up and sends users reminders to stay hydrated. Meanwhile, every time the user refills the REBO bottle, a credit is produced which funds the collection of a tossed-away plastic bottle. Those credits are notarized on a day-to-day basis in a blockchain. This is part of the business model that REBO has created to enable the funding of ocean-bound plastic waste collections in developing regions.

The REBO's crowdfunding campaign started in 2019 and was successful with 220,492 € raised from 2403 different backers (Indiegogo, 2022). It then underwent industrialisation to deliver the first products in early 2021. Bottle is currently for sale for 89€ on the company's website.

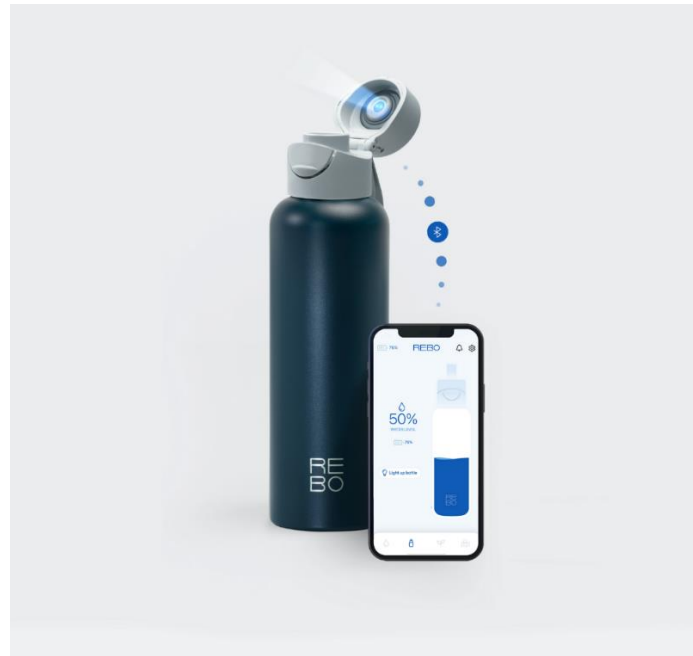

Figure 5-1. Commercial illustration of the REBO bottle

5.2 The REBO baselines

This section will briefly describe the baselines that were progressively built-in order to set the scene for the use-case description. Please refer to the two product's patents (Abbate et al., 2022) and (Lopez et al., 2022) for an exhaustive technical description of the product.

5.2.1 As Required

The As Required product description came in an unstructured form: from Indiegogo page on the one side and from a standard user-journey on the other side. The whole can be assimilated to User Requirement Specifications (URS).

The Indiegogo page stated a few of the product's feature as well as some of the leveraged technologies without many details as shown in Figure 5-2 below.



Figure 5-2. As Required elements from the crowdfunding website (Indiegogo, 2022)

In addition to the elements on Indiegogo, the user-journey was:

“Jane fills up her bottle with some boiling hot tea in the morning and as she is running late, she puts the bottle upside down in her bag, luckily enough, she knows the cap will not open unexpectedly!

Once at work, she drinks as the LED ring flashes white for 10 seconds, indicating her she should drink (every two hours). While having the other hand busy, Jane can single-handedly open the bottle just by pressing the button at the front, the spring will then open the lid. As the afternoon is hot, at lunch time she puts her favourite soda along with some ice-cubes in the bottle. When she gets home, she will put the bottle in the fridge as some of the soda is left.

To clean the bottle, she will unscrew the cap from the bottle body, put the bottle body to wash in the dishwasher and wash the cap manually.

Every two months, she will then put the cap to charge. The led colour will be red while charging and turn green when the battery is charged. In case the data has not been synchronised during use, Jane will connect her app to the bottle to retrieve drinking data.”

Following our proposition, at this stage of development, the product's capabilities should be described in both PLM software and IoT Platform and linked together. In this case, this would mean that the product's four Reacting, Interfacing, Storing and Data Processing need to be outlined:

- Reacting components are the battery charging (sensing) and the water consumption sensing components.
- Interfacing components could be the bottle opening/closing mechanism, the LED ring as well as the app. We, of course, glimpse at an interface between the bottle and the app despite not necessarily being thoroughly defined at first.
- Storing and data processing functions can be drafted from the Smart Bottle side as well as the smartphone.

5.2.1.1 As Defined

Following these requirements, a definition of the product needed to be put in place. The architecture was composed of a back end server, a mobile application and the REBO smart bottle.

The REBO smart bottle was sketched out and was roughly defined as:

Final Product:

- *Packaging*
- *Body bottle*
- *Cap*
 - *Lace*
 - *LED ring cover*
 - *Lid insert*
 - *Pin*
 - *Lid (including sealing with the nozzle)*
 - *Body (including sealing ring with bottle)*

- *Electronics including accelerometer (LIS2DE12, ST Micro), time-of-flight sensor, photosensor, battery for 2 months (capacity TBD based on module and use-case), USB-C connector, LEDs (red/green/white), BLE module (Nordic 52810 series based)*
- *Spring (a silicon ring) in the lid*
- *NFC chip*
- *1 meter USB-C cable*

As you can see, some of the key components are already carved out while others are still on a low level of detail. These elements are defined later either because depending on the main components or not on the project's critical path to industrialisation.

Following our proposition and following the product's further development, the capabilities should be refined further. In this case, this would mean that the product's four Reacting, Interfacing, Storing and Data Processing need to be defined as:

- Reacting: battery charger (sensing), water consumption sensing components (accelerometer, time-of-flight sensor, photosensor);
- Interfacing: Device to Human: bottle opening/closing mechanism, LED ring, NFC chip;
- Interfacing: Device to Smartphone: BLE protocol (via both BLE modules);
- Interfacing: Smartphone to Human (App) and Smartphone to Back-end;
- Storing on Device: TBD with customer depending on offline storage need;
- Data Processing Device: sufficient to enable the water consumption sensing as well as the battery management;
- Storing & Data Processing in the back end: in the cloud, enabling scalability if necessary.

In this case, we do not bother refining the Smartphone I, S and P as the smartphone's operating system (iOS, Android, LineageOS) is the biggest limiting factor to the App definition and therefore the product's development. Also, the multitude of available smartphone prohibits considering each one individually.

5.2.2 As Developed

Following the product definition, all the components had to be fleshed out: the mechanical components (cf. Figure 5-3), the printed circuit board (PCB), the firmware, the app (cf. Figure 5-4), etc.

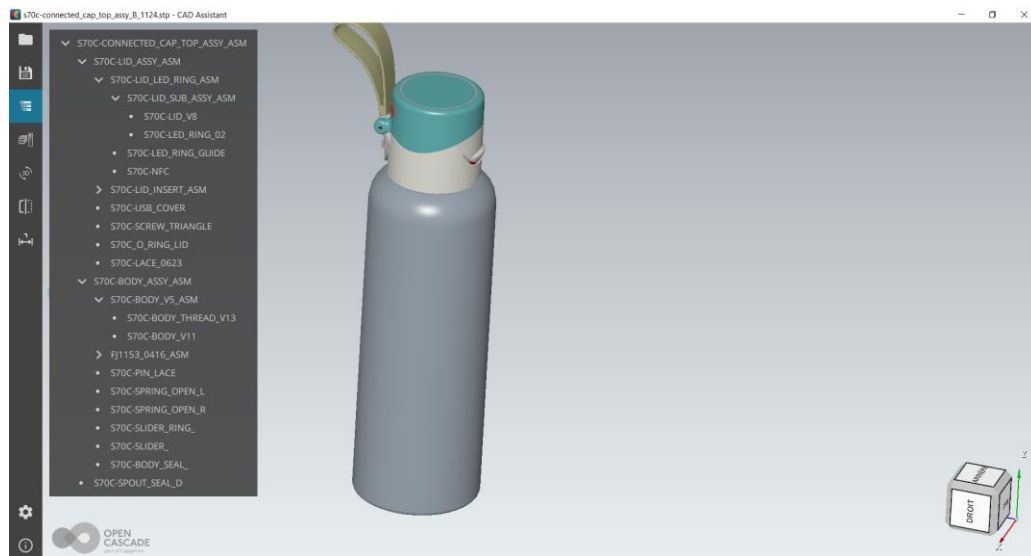

Figure 5-3. CAD model of the REBO bottle

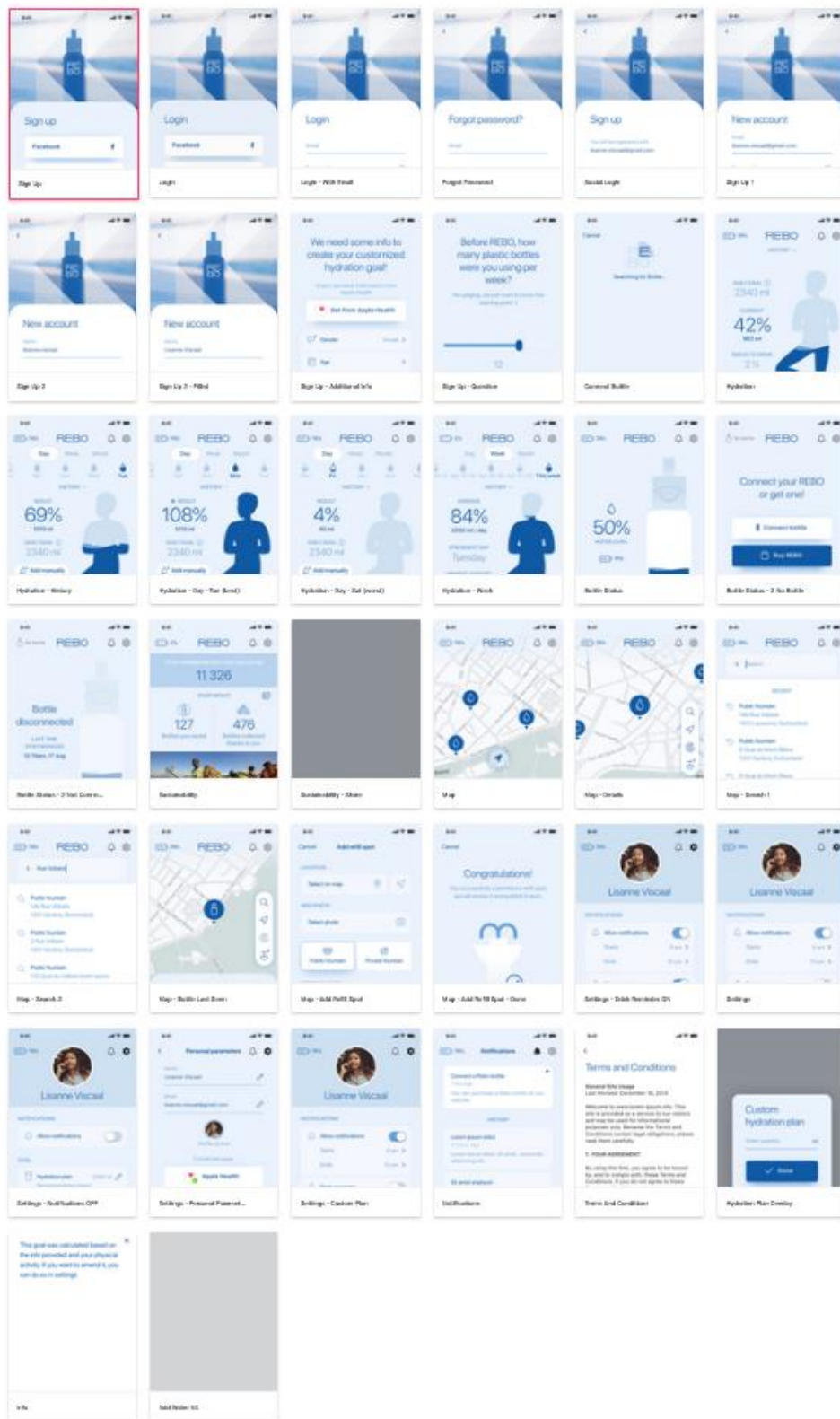

Figure 5-4. Draft design of the REBO app

Reflecting on our proposition, all Reacting, Interfacing, Storing and Data Processing functions are cascaded to the components in the PLM software at this point as well as being fully defined on the IoT Platform too.

5.2.2.1 As Built

The As Built baseline is composed of all the industrialised components of the Smart Bottle side but also in terms of software architecture. For instance, the back end services supporting the mobile application is fully put in place (cf. Figure 5-5).

version: 1.0.0

Id	User name/email	Type	Quantity	Manual	Created date
7375	sepp 62zed8niqz@privaterelay.appleid.com	Consume	107	no	23/01/2021
7376	sepp 62zed8niqz@privaterelay.appleid.com	Fill	50	no	23/01/2021
7430	sepp 62zed8niqz@privaterelay.appleid.com	Fill	510	no	24/01/2021
7431	sepp 62zed8niqz@privaterelay.appleid.com	Consume	111	no	24/01/2021
7443	sepp 62zed8niqz@privaterelay.appleid.com	Fill	111	no	24/01/2021
7444	sepp 62zed8niqz@privaterelay.appleid.com	Consume	500	yes	24/01/2021

Rows per page: 10 ▾ 31 - 40 / 13,770 < >

Figure 5-5. Dashboard enabling Blockchain credit generation

At this point, our proposition turns towards the triggering of the feedback loop where the Problem Report (and Change Management) as a medium approach comes through.

5.2.2.2 As Maintained

Given the limited existence of the REBO, the maintenance BOM is developed as issues are detected on the product. For instance, users reported issues with the silicone lace which lead to putting in place a replacement program with a survey as an input (cf. Figure 5-6) and culminating with the reception of a new lace.

As the product matures and ages, the feedback loop aligning the ‘As to be’ and ‘As Maintained / As Built’ becomes increasingly fruitful and enabling further product line development.

The image shows a survey form for REBO. At the top is the REBO logo, which consists of two blue triangles pointing left followed by the word 'REBO' in a blue, outlined font. Below the logo is a white box with a blue border containing the following text:

Dear Customers : Silicone Laces performance

The performance of some of the silicone laces are not being as good as expected. If your lace has unexpectedly broken, please fill this form so we can send you a spare lace for free.

Below the text is a user identification section showing an email address 'piersbarrios@gmail.com (not shared)' with a 'Switch accounts' link and a cloud icon. A red asterisk indicates a required field.

The main question is 'Has your lace/s unexpectedly broken? *'. Below this question are two radio button options: 'Yes' and 'No'.

Figure 5-6. Survey excerpt enabling REBO Silicone Lace replacement

5.3 Use-cases

Now that the scene is set with the baselines in place, we shall explore various use cases (three real use-cases and theoretical ones) to apply our proposition and assess its relevance.

5.3.1 Three real use-cases

The three following use-cases come from situations we had to handle in a “manual” way and where the proposition would have been useful.

5.3.1.1 Adjustments compared to the moulds

When cooling off after moulding, a plastic part tends to shrink. This can be simulated but to a limited extent. If the part does not shrink enough, the mould can be reworked to refit for a bigger part; on the other side if the part shrinks too much, the mould will have to be re-done to allow for

a bigger part. Given the price of a mould, it is sometimes preferable to adjust electronics or the other plastic parts, which can easily be done if a feedback loop through problem report is enabled; else the additional cost and lead-time associated to sending the information back to the PLM software might implicate that it is more effective to actually change and redo the component rather than adapting the following ones.

With our proposition, we would have been able to streamline the manufacturing and therefore avoid having to redo moulds as the other components were already frozen by the time the information was cascaded. Un-freezing them would lead to extra cost and complexity.

5.3.1.2 Issue on the electronics

Despite extensive testing, not all issues can be detected in the controlled environment, as some unique sequence of events might be the trigger for an issue. This is especially the case with the electronics as the custom electronics board design leads to some particularities. In this case, the Time-of-Flight (TOF) sensor was shutting itself down due to power drop at given times. This feedback only came from user testing and was a hard one to track down.

With our proposition, the Smart Bottle would have been able to log events in the IoT Platform of the cap opening and closing a certain number of times without having a TOF reading triggered. This would then have generated a problem report sent to the PLM software for the issue to be investigated.

5.3.1.3 Battery level is -1%

At a given point, the back end stored values of battery level as being -1%. By definition and convention, the battery is expressed as a percentage between 0% and 100%. This is therefore an issue. However, the fact that the bottle was still being able to send data to the mobile application directly implied that the battery was far from empty. We therefore needed to understand where the issue was coming from: the back end, the app, or the Smart Bottle. In a complex product, the Chain of custody is not always as explicit as the product grows and can lead to the investigation growing exponentially. We managed to chase down the issue to the firmware running on the device which was not calculating the level correctly.

With our proposition, based on the product definition given with the As Required & As Defined baseline, an alert would have been raised as soon as a defective. Moreover, in this case, part of the logic elements part of the IoT Platform could be externalised in the smartphone in order to enable edge computing capabilities.

5.3.2 Theoretical use-cases

The following use-case is not based on actual experience during the REBO Smart Bottle development and operation but reflect other potential situations where our proposal could come in place and add value; for instance Improving component selection.

As we are experiencing global component shortages, our proposal could allow one to delay the electronic component selection as the product is described in terms of functions (and enabled as such in the IoT Platform). Therefore, multiple components could fit the requirements instead of defining the requirements according to the available components on the market at a given time.

5.4 Validation

On the validation side of things, we need to reflect on the criteria outlined at the end of Chapter 3, namely:

- We are in a “discrete manufacturing industry context”;

REBO Smart Bottle is a consumer electronic device, so we are indeed in discrete manufacturing context.

- We have product lifecycle management information;

The baselines were explained and the various PLM information lied out.

- That part of this is engineering information.

As we seen, we have CAD

- We have data from connected objects;

The Smart Connected bottle is indeed a connected object.

- Those data are of various nature

We see distinct types of data: user feedback, sensor, and identifiers. The only one that was not involved in the use-cases was actuators despite the REBO having a LED ring, but we choose to classify this component as an interface.

- Both the PLM information and the IoT data are linked.

Indeed, the information between PLM and IoT are linked.

With this chapter, a validation of the proposition was done on the REBO smart bottle - industrialised by the author - with the aim to make it easily understandable by the reader and provide sufficient artefacts to illustrate the proposal. Next chapter is dedicated to discussion of the presented use-case as well as the proposition and the industrial readiness of it.

CHAPTER 6 DISCUSSION

This chapter acknowledges the limitations of the proposed research as well as discussing the potential extents and implications of it. We shall first address the reproducibility and validity of the work before discussing the adaptability of the method to other industrial contexts as well as regarding product complexity and support complexity. Finally, we will lean on to the Digital Twin to understand how this proposition could contribute to its adoption.

6.1 On the reproducibility of the Industrial readiness

Industrial readiness was sketched based on the use of Windchill as IT PLM and ThingWorx as IoT Platform. Those were picked because they both qualify as best in class software but also because best known to the author than the other existing solutions. Nevertheless, PLM state of the art showed in *2.2.2.1 PLM software functionalities studies* that multiple PLM software had similar functions to the one picked. In an analogous way, the IoT Platform state of the art showed that multiple platforms carried the essential functionalities. Moreover, the IoT Platforms' overall maturity is improving and even if the number of platforms equivalent to the chosen one might be limited at this given time, we assume, based on recursive reasoning that we will attain a consequent number in the future.

We therefore assume to safely infer that the industrial readiness, despite only being built upon a single software duo of top-notch software, is generalizable to all major PLM software and IoT Platforms.

6.2 Limits to validation

The validation proposed in Chapter 5 is limited and needs to be discussed. We shall discuss this in three ways: implementation extension, criteria challenging and before/after comparisons.

First, the validation should be extended by the use of a full-fledged implementation. Indeed, we relied here on a case study describing how situation were without the implementation being done and how they would be with the proposition being fully implemented. Therefore, a formal validation would require extending the implementation to an actual system and to re-demonstrate the use-cases outlined here.

Secondly, the criteria could be challenged and prolonged. Indeed, one could propose further criteria in order to ensure a validation from multiple stakeholders in an industrial context. Such criteria could materialise as cost, implementation lead time, resources necessary as well as certification of the solution and cybersecurity aspects. The validation could happen on technical solutions where the components have been individually validated. In the future, we could foresee the emergence of solutions enabling the direct integration of the proposed novel approaches.

Thirdly, the comparison between before and after pictures could be described further. However, in practice, it is quite challenging to get a still picture of the environment from a holistic point of view. Indeed, as one items gets pictured this impacts directly the shape of the following ones. This would however contribute to enabling performance, safety and risks comparisons between pre-proposition system and the one following the implementation.

Last but not least, as outlined in the state-of-the-art, PLM's return on investment is not clearly proven by the literature so far; this could be added to the limits to the validation.

6.3 On the adaptability of the methodological framework

The actual extent of the methodological framework can be discussed as it was only validated upon a particular type of manufacturing environment with a given product and its associated support. We shall therefore take the discussion towards product's complexity then support complexity before closing off with the typology of actors. We start off by disclosing that, through further refining, the current proposition might end up the same was that PROMISE did, i.e. proposing different subsets to better fit the industrial needs (Kiritsis, 2011).

		Industrial strategies			
		Engineering to order	Make to order	Assemble to order	Make to Stock
Product complexity	Low	Pumps	Rail cars	Boats	Domestic appliances, Bicycles, Lawn equipment, Valves, Filters & Brakes
	Medium	Process plants, Military vehicles	Agricultural machinery, Trucks, Mining equipment	Automobiles, Transmissions, Engines	Computers, Leisure vehicles, Elevators
	High	Satellites, Military missiles, ship and aircraft, Commercial ships, Power plants, Oil production rigs	Commercial aircraft	Avionics, Aircraft engines	

Figure 6-1. “Product classification depending on product complexity and industrial strategies”, from (Barrios et al., 2022)

6.3.1 Product complexity

The product complexity directly impacts the number of instances of the product that are manufactured. Indeed, more complex product will have a tendency to be instantiated only a few times or even once. For instance, aircrafts and ships tend to only exist in a limited number. The proposition is directly impacted through its Product Instantiation component as in most cases the information will have to go through a middleware (e.g., ERP) in order to match information from the PLM software and the IoT Platform.

6.3.2 Support complexity

The support complexity of a product will make the proposition increasingly relevant as the support is extended in time and complexity. Indeed, being able to automatically link information from the product instances via IoT to the PLM software will enable to lessen the burden of relying on multiple expert knowledge. More industries are indeed confronted to experts retiring thus impacting the possibility for a product to be correctly maintained over time.

6.3.3 Typology of actors

The industrial strategy needs to be taken into consideration, an ‘engineering to order’ product will not have the same needs as a ‘make to stock’ product. Indeed, engineer to order products will not benefit as much from what was put in place here as the back and forth of product data currently happens in a more or less automatic way. However, our proposal will most benefit to the other types of actors as these will see the implementation of an automated feedback loop from their various product instances to the product definition in the PLM software environment. Therefore, the product lines will be able to evolve in a more flexible way than they currently are as the product definition can be incrementally improved as increasingly of a given product goes on the market.

Finally, the testing and certification of a given product could, thanks to the proposition, come from the data collected by the information system rather than having to freeze the design and go through a time-consuming process of certification. This indeed would enable a faster time to market and an increased speed of innovation to be available. Given the current climate crisis, this reduced lead time could enable the experimentation of multiple product definitions in order to keep the most sustainable one, given the user’s behaviours.

6.4 A contribution to the Digital Twin

As the digital twin has emerged as the latest fashionable concept for IT vendors, many a practitioner will look towards this PhD thesis to understand how it is related or relatable. As outlined in Chapter 2, Digital Twin concept does not yet have a standard definition to it. We shall therefore consider some of the previously referenced literature in order to assess the compatibility of our proposition with that of the Digital Twin concept.

First, the proposition here could be indeed positioned as a Digital Twin (stage 4) when regarding (Weber et al., 2017)’s Maturity Model for Data-Driven Manufacturing (Figure 2-19). Indeed, this could be viewed as a partial aggregation of assets for the creation of the “centralized platform for monitoring decentralized and autonomous assets”. Secondly and turning towards (Kritzinger et al., 2018), we argue that the proposition situates itself between the Digital Shadow and the Digital Twin. Indeed, we do not recommend that an automatic data flow be put in place on all situations as experts are still needed in the loop to check on the feedback as well as deciding, through the

change process of what needs to be adjusted. Finally, this proposition aligns with the (ISO/FDIS 23247, 2021) definition, keeping in mind the vagueness of it.

As a conclusion, we suggest that our proposition indeed contributes to the Digital Twin concept while keeping in mind the absence of consensus around its definition therefore making it easy to miss a moving target.

This closes off our discussion chapter where we addressed the reproducibility and validity of the work and the adaptability of the method to other industrial situations. Proposition was also challenged in terms of product complexity and support complexity. Last but not least, Digital Twin was argued upon, and we suggest our proposition contributes to the Digital Twin concept.

6.5 Synthesis and discussion wrap-up

This chapter recognized the limitations of the proposed study and discussed its potential scope and implications. After having discussed the applicability of the method to other industrial situations, as well as the complexity of the product and support, we have discussed the reproducibility and validity of our work. Finally, we have argued about the digital twin in regard to the proposition and that future of Digital Twin should be effective and operational implementation.

CHAPTER 7 CONCLUSION (AND FUTURE WORK)

After introducing the global challenges of product servitisation and pay to use with the aim of a sustainable future, the introduction continues on aligning on IoT and IIoT definitions on the base of existing literature and standards:

Internet of things is an infrastructure of interconnected entities, people, systems, and information resources together with services, which exchanges information between physical and virtual world by sensing, processing information and actuating

Industrial Internet of things is the use-case point of view resulting of the application of Internet of Things to the Industrial sector.

Following this, we phrased the following research problem statement:

How to ensure a digital thread between PLM and IoT eco-systems?

State of the art demonstrated inadequacy of enterprise modeling techniques and architectures, as well as the latest literature in PLM, IoT and in joint literature. Interoperability research demonstrated the need for semantic interoperability via integration and/or unification. We then briefly addressed the novel concepts of Digital Twin and Cyber Physical Systems as our proposition might contribute to them. Out of the state of the art, we established the research question:

RQ: What framework could be used to produce an industry-ready solution to ensure a digital thread between PLM and IoT Information systems?

This was answered by proposing a novel framework made of four existing blocks (Baseline, Change Management, Product Instantiation, and IoT Information Structuring) and adding three novel approaches (Function-enabled PLM, Problem report as a medium and Enrichment of ‘As to be’ baselines). This enables instantiation of IT PLM data in IoT Platforms as well as the generalization of IoT Platforms’ data in PLM. This proposal is condensed in Figure 7-1 below.

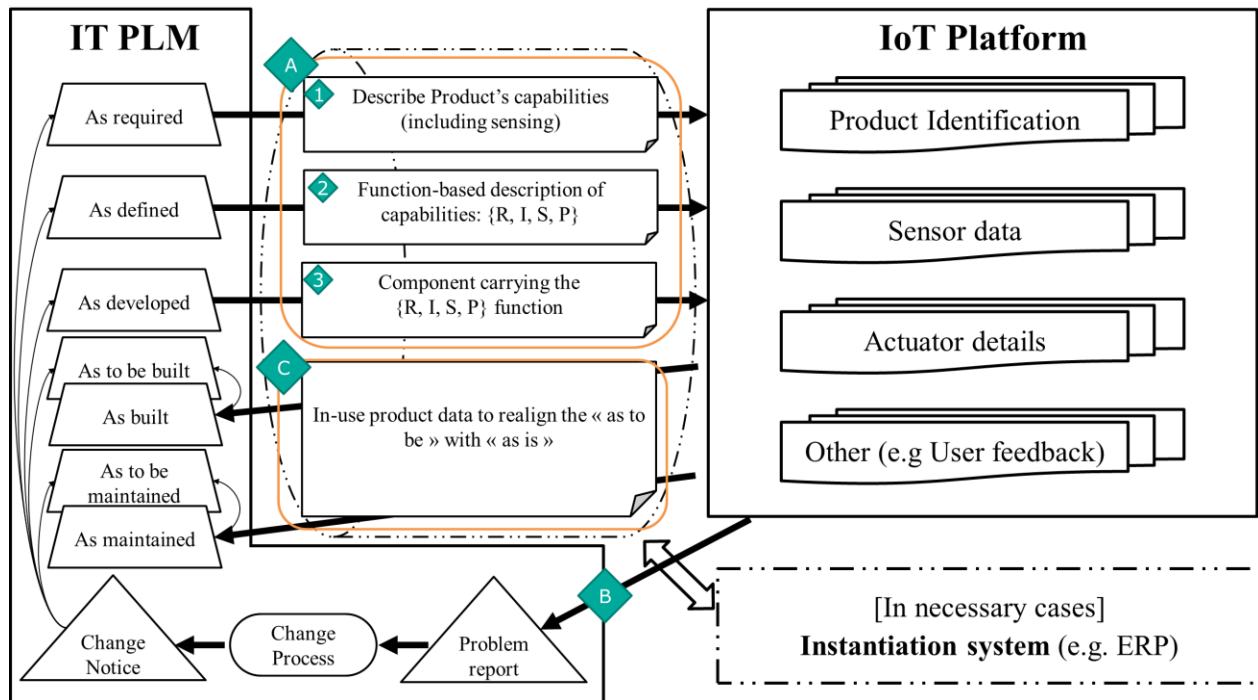

Figure 7-1. The Methodological Framework for a Digital Thread between PLM and IoT

Furthermore, we demonstrated the industrial readiness of the proposed methodological framework through the elaboration of implementation guidelines. This leveraged the Windchill PLM Software as well as the ThingWorx IoT Platform and dived into details on either side about features that could be used Out-of-the-Box, those requiring platform configuration or even involving software customisation. We also discussed the effort implementation would take ex nihilo as well as in an industrial context.

After having presented the REBO Smart Bottle case study, validation was done on the basis of three real use-cases where we demonstrated the added value of the proposition. Further use-cases were also presented and discussed.

Finally, discussion addressed the reproducibility and validity of the research work as well as the adaptability of the method to other industrial contexts. We also challenged it in regard to product complexity and support complexity. Last but not least, Digital Twin was argued upon, and we suggest our proposition contributes to the Digital Twin concept.

Future work is to be considered in a threefold manner. First, we will address some direct commentary work of this PhD thesis, a second part will address gaps that were outlined throughout the state of the art and from which we took assumptions. Finally, the last part will track the main challenges and research trends that need to be further researched.

Future work should include challenging and reinforcing these research works via the implementation of the proposition as described in subsection 4.1 as well as the architecture of such implementation on other existing software vendor solutions. If sufficient progress of federated interoperability and ontologies allow it, this proposition should be mapped and implement as such. Moreover, the interoperability of enterprise software needs to be addressed in a major way in order to prevent any possible vendor lock-ins. Future work must include the development of professional competences able to tackle such cross-sector domain as the ones outlined here.

Other future work could study real industrial enterprise software implementations in order to induce guidelines, their value, and their usage. Moreover, this could be combined with attempting to formally demonstrate the added-value and return on investment of PLM projects and namely the human training and information system components of it (with the hypothesis that human training produces more value than the evolution of the software). Also, given the ensured digital thread between PLM software and IoT Platform, reconfiguration in operation opportunities should be accurately assessed.

Finally, and looping back to the original questioning about tackling climate crisis, future work must pave a way to a more responsible future for IoT and the lowering of ICT global emissions. (Or future shall not be). In this regard, advanced investigation of Industry 5.0 opportunities as well as global sustainability should be pursued.

AUTHOR'S WORK

International Journal

Barrios, P., Danjou, C., & Eynard, B. (2022). Literature review and methodological framework for integration of IoT and PLM in manufacturing industry. *Computers in Industry*, *140*, 103688. <https://doi.org/10.1016/j.compind.2022.103688>

International conference

Santana, J., **Barrios, P.**, & Eynard, B. (2021). Intégration d'objets connectés: Eléments d'aide au choix de plateforme IIoT. *CIGI QUALITA 2019: 14è Congrès International de Génie Industriel et QUALITA*, 8.

Barrios, P., Loison, F., Danjou, C., & Eynard, B. (2020). PLM Migration in the Era of Big Data and IoT: Analysis of Information System and Data Topology. *Product Lifecycle Management Enabling Smart X*, *594*, 695–708. https://doi.org/10.1007/978-3-030-62807-9_55

Loison, F., **Barrios, P.**, Danjou, C., & Eynard, B. (2020, November). Analyse Topologique des Structures de Données: Application à la Migration des Systèmes d'Information d'Entreprise. *13ème Conference Internationale De Modelisation, Optimisation et Simulation (MOSIM2020)*. <https://hal.archives-ouvertes.fr/hal-03177804>

Barrios, P., Danjou, C., & Eynard, B. (2019a). Product lifecycle management et Industrial Internet of Things: Revue systématique de la bibliographie. *CIGI QUALITA 2019: 13è Congrès International de Génie Industriel et QUALITA*, 7.

Barrios, P., Eynard, B., & Danjou, C. (2019b). Towards a Digital Thread Between Industrial Internet of Things and Product Lifecycle Management: Experimental Work for Prototype Implementation. In C. Fortin, L. Rivest, A. Bernard, & A. Bouras (Eds.), *Product Lifecycle*

Management in the Digital Twin Era (pp. 273–282). Springer International Publishing.

https://doi.org/10.1007/978-3-030-42250-9_26

Patents

The author also contributed to the elaboration of the following patents on the REBO smart bottle:

López, J. V. V., Quarta, P., & Abbate, F. (2022). *Smart bottle* (World Intellectual Property Organization Patent No. WO2022033666A1).

<https://patents.google.com/patent/WO2022033666A1>

Abbate, F., Quarta, P., & López, J. V. V. (2022). *Drinking bottle* (European Union Patent No. EP4005431A1). <https://patents.google.com/patent/EP4005431A1/>

REFERENCES

- Abbate, F., Quarta, P., & Lopez, J. V. V. (2022). *Drinking bottle* (European Union Patent EP4005431A1). <https://patents.google.com/patent/EP4005431A1/>
- Aberle, L. (2015). *A comprehensive guide to enterprise IoT project success*. IoT Agenda. <https://internetofthingsagenda.techtarget.com/essentialguide/A-comprehensive-guide-to-enterprise-IoT-project-success>
- Ahmadi, A., Cherifi, C., Cheutet, V., & Ouzrout, Y. (2017). A review of CPS 5 components architecture for manufacturing based on standards. *2017 11th International Conference on Software, Knowledge, Information Management and Applications (SKIMA)*, 1–6. <https://doi.org/10.1109/SKIMA.2017.8294091>
- Alemanni, M., Alessia, G., Tornincasa, S., & Vezzetti, E. (2008). Key performance indicators for PLM benefits evaluation: The Alcatel Alenia Space case study. *Computers in Industry*, 59(8), Article 8. <https://doi.org/10.1016/j.compind.2008.06.003>
- Aristotle. (980). *Metaphysics*, Book 8, section 1045a. <http://www.perseus.tufts.edu/hopper/text?doc=Perseus%3Atext%3A1999.01.0052%3Abook%3D8%3Asection%3D1045a>
- Bandinelli, R., Fani, V., & Bindi, B. (2021). PLM functionalities in the fashion industry. A classification framework. *International Journal of Product Lifecycle Management*, 13(2), 186. <https://doi.org/10.1504/IJPLM.2021.116217>
- Barrios, P., Danjou, C., & Eynard, B. (2019). Product lifecycle management et Industrial Internet of Things: Revue systématique de la bibliographie. *CIGI QUALITA 2019: 13ème Congrès International de Génie Industriel et QUALITA*, 7.

- Barrios, P., Danjou, C., & Eynard, B. (2022). Literature review and methodological framework for integration of IoT and PLM in manufacturing industry. *Computers in Industry, 140*, 103688. <https://doi.org/10.1016/j.compind.2022.103688>
- Barrios, P., Eynard, B., & Danjou, C. (2019). Towards a Digital Thread Between Industrial Internet of Things and Product Lifecycle Management: Experimental Work for Prototype Implementation. In C. Fortin, L. Rivest, A. Bernard, & A. Bouras (Eds.), *Product Lifecycle Management in the Digital Twin Era* (pp. 273–282). Springer International Publishing. https://doi.org/10.1007/978-3-030-42250-9_26
- Barrios, P., Loison, F., Danjou, C., & Eynard, B. (2020). PLM Migration in the Era of Big Data and IoT: Analysis of Information System and Data Topology. *Product Lifecycle Management Enabling Smart X, 594*, 695–708. https://doi.org/10.1007/978-3-030-62807-9_55
- Bernus, P., & Nemes, L. (1996). A framework to define a generic enterprise reference architecture and methodology. *Computer Integrated Manufacturing Systems, 9*(3), 179–191. [https://doi.org/10.1016/S0951-5240\(96\)00001-8](https://doi.org/10.1016/S0951-5240(96)00001-8)
- Bokinge, M., & Malmqvist, J. (2012). PLM implementation guidelines—relevance and application in practice: A discussion of findings from a retrospective case study. *International Journal of Product Lifecycle Management, 6*(1), 79–98. <https://doi.org/10.1504/IJPLM.2012.046442>
- Boyes, H., Hallaq, B., Cunningham, J., & Watson, T. (2018). The industrial internet of things (IIoT): An analysis framework. *Computers in Industry, 101*, 1–12. <https://doi.org/10.1016/j.compind.2018.04.015>

- Bruel, A., Kronenberg, J., Troussier, N., & Guillaume, B. (2019). Linking Industrial Ecology and Ecological Economics: A Theoretical and Empirical Foundation for the Circular Economy. *Journal of Industrial Ecology*, 23(1), 12–21. <https://doi.org/10.1111/jieec.12745>
- Cadoret, T., Danjou, C., & Duigou, J. L. (2021). Intégration verticale pour le pilotage des systèmes de production: Un état de l’art. *CIGI QUALITA 2021: 14ème Congrès International de Génie Industriel et QUALITA*, 8.
- Chen, D., Doumeingts, G., & Vernadat, F. (2008). Architectures for enterprise integration and interoperability: Past, present and future. *Computers in Industry*, 59(7), 647–659. <https://doi.org/10.1016/j.compind.2007.12.016>
- Chen, D., Vallespir, B., & Doumeingts, G. (1997). GRAI integrated methodology and its mapping onto generic enterprise reference architecture and methodology. *Computers in Industry*, 33(2–3), 387–394. [https://doi.org/10.1016/S0166-3615\(97\)00043-2](https://doi.org/10.1016/S0166-3615(97)00043-2)
- Choi, H., Song, J., & Yi, K. (2018). Brightics-IoT: Towards Effective Industrial IoT Platforms for Connected Smart Factories. *2018 IEEE International Conference on Industrial Internet (ICII)*, 146–152. <https://doi.org/10.1109/ICII.2018.00024>
- Cimino, C., Negri, E., & Fumagalli, L. (2019). Review of digital twin applications in manufacturing. *Computers in Industry*, 113, 103130. <https://doi.org/10.1016/j.compind.2019.103130>
- CIMOSA. (2022). *CIMOSA*. <http://www.pera.net/Methodologies/Cimosa/CIMOSA.html>
- CIMOSA News. (2022). *CIMOSA News*. http://www.cimosa.de/CoAssoc/NewWebS/Frame1/About_us.htm

- Cusick, J. J. (2019). *A Survey of Maturity Models from Nolon to DevOps and Their Applications in Process Improvement*. <https://doi.org/10.48550/ARXIV.1907.01878>
- Danjou, C. (2015). *Ingénierie de la chaîne numérique d'industrialisation: Proposition d'un modèle d'interopérabilité pour la conception-fabrication intégrées* [PhD Thesis]. Université de technologie de Compiègne.
- Dekoninck, E. A., Domingo, L., O'Hare, J. A., Pigosso, D. C. A., Reyes, T., & Troussier, N. (2016). Defining the challenges for ecodesign implementation in companies: Development and consolidation of a framework. *Journal of Cleaner Production*, *135*, 410–425. <https://doi.org/10.1016/j.jclepro.2016.06.045>
- Demoly, F., Pels, H. J., & Gomes, S. (2013). Proactive Engineering and PLM: Current Status and Research Challenges. In A. Bernard, L. Rivest, & D. Dutta (Eds.), *Product Lifecycle Management for Society* (Vol. 409, pp. 170–181). Springer Berlin Heidelberg. https://doi.org/10.1007/978-3-642-41501-2_18
- Doumeingts, G. (1984). *Méthode GRAI: méthode de conception des systèmes en productique* [Habilitation thesis, Université de Bordeaux]. <https://books.google.fr/books?id=0EnKMgEACAAJ>
- El Kadiri, S., Grabot, B., Thoben, K.-D., Hribernik, K., Emmanouilidis, C., von Cieminski, G., & Kiritsis, D. (2016). Current trends on ICT technologies for enterprise information systems. *Computers in Industry*, *79*, 14–33. <https://doi.org/10.1016/j.compind.2015.06.008>
- Enríquez, J. G., Sánchez-Begines, J. M., Domínguez-Mayo, F. J., García-García, J. A., & Escalona, M. J. (2019). An approach to characterize and evaluate the quality of Product Lifecycle

- Management Software Systems. *Computer Standards & Interfaces*, 61, 77–88.
<https://doi.org/10.1016/j.csi.2018.05.003>
- Eriksson, D. (1997). A Principal Exposition of Jean-Louis Le Moigne’s Systemic Theory. *Cybernetics and Human Knowing*, 4(2–3), 42.
- European Commission. (2022). *EU-US data transfers* [Text]. European Commission - European Commission. https://ec.europa.eu/info/law/law-topic/data-protection/international-dimension-data-protection/eu-us-data-transfers_en
- European Commission. Directorate General for Informatics. (2017). *New European interoperability framework: Promoting seamless services and data flows for European public administrations*. Publications Office. <https://data.europa.eu/doi/10.2799/78681>
- GDPR, Pub. L. No. 32016R0679, 2016/679 REGULATION (EU) (2016). <https://eur-lex.europa.eu/eli/reg/2016/679/oj>
- Eynard, B. (1999). *Modélisation du produit et des activités de conception: Contribution à la conduite et à la traçabilité du processus d’ingénierie* [PhD Thesis, Université de Bordeaux 1]. <https://www.theses.fr/1999BOR10571>
- Eynard, B., & Bosch-Mauchand, M. (2015). Integrated design and smart manufacturing. *Concurrent Engineering*, 23(4), 281–283. <https://doi.org/10.1177/1063293X15607367>
- Eynard, B., Gallet, T., Nowak, P., & Roucoules, L. (2004). UML based specifications of PDM product structure and workflow. *Computers in Industry*, 55(3), 301–316.
<https://doi.org/10.1016/j.compind.2004.08.006>

- Fani, V., Bandinelli, R., & Bindi, B. (2020). PLM Functionalities in the Fashion Industry. Preliminary Results of a Classification Framework. In F. Nyffenegger, J. Ríos, L. Rivest, & A. Bouras (Eds.), *Product Lifecycle Management Enabling Smart X* (Vol. 594, pp. 527–537). Springer. https://doi.org/10.1007/978-3-030-62807-9_42
- Fielding, R. T., & Reschke, J. (2014). *Hypertext Transfer Protocol (HTTP/1.1): Semantics and Content* (Request for Comments RFC 7231). Internet Engineering Task Force. <https://doi.org/10.17487/RFC7231>
- Fortineau, V. (2013). *Contribution à une modélisation ontologique des informations tout au long du cycle de vie du produit* (Issue 2014ENAM0049) [PhD Thesis, Ecole nationale supérieure d'arts et métiers - ENSAM]. <https://pastel.archives-ouvertes.fr/pastel-01064598>
- Freitag, C., Berners-Lee, M., Widdicks, K., Knowles, B., Blair, G. S., & Friday, A. (2021). The real climate and transformative impact of ICT: A critique of estimates, trends, and regulations. *Patterns*, 2(9), 100340. <https://doi.org/10.1016/j.patter.2021.100340>
- Gartner. (2020). *Magic Quadrant for Industrial IoT Platforms*. Gartner. <https://www.gartner.com/doc/reprints?id=1-2434LPHV&ct=200903&st=sb>
- Gartner. (2021). *Magic Quadrant for Industrial IoT Platforms*. Gartner. <https://www.gartner.com/en/documents/4006918>
- Global Igi. (2019). *What is Methodological Framework | IGI Global*. <https://www.igi-global.com/dictionary/methodological-framework/18485>
- Personal Data Protection Bill, (2019).

- Halpern, M. (2006). *Magic Quadrant for Product Life Cycle Management, 3Q06*. Gartner. <https://www.gartner.com/en/documents/496749/magic-quadrant-for-product-life-cycle-management-3q06>
- Hedberg, T., Lubell, J., Fischer, L., Maggiano, L., & Barnard Feeney, A. (2016). Testing the Digital Thread in Support of Model-Based Manufacturing and Inspection. *Journal of Computing and Information Science in Engineering*, *16*(2), 021001. <https://doi.org/10.1115/1.4032697>
- Hehenberger, P., Vogel-Heuser, B., Bradley, D., Eynard, B., Tomiyama, T., & Achiche, S. (2016). Design, modelling, simulation and integration of cyber physical systems: Methods and applications. *Computers in Industry*, *82*, 273–289. <https://doi.org/10.1016/j.compind.2016.05.006>
- Hickel, J., & Kallis, G. (2020). Is Green Growth Possible? *New Political Economy*, *25*(4), 469–486. <https://doi.org/10.1080/13563467.2019.1598964>
- Hoffmann, J., Heimes, P., & Senel, S. (2018). IoT Platforms for the Internet of Production. *IEEE Internet of Things Journal*, 1–1. <https://doi.org/10.1109/JIOT.2018.2875594>
- Iden, J., & Eikebrokk, T. R. (2013). Implementing IT Service Management: A systematic literature review. *International Journal of Information Management*, *33*(3), 512–523. <https://doi.org/10.1016/j.ijinfomgt.2013.01.004>
- IEEE 2413-2019. (2020). *IEEE Standard for an Architectural Framework for the Internet of Things (IoT)*. IEEE. <https://doi.org/10.1109/IEEESTD.2020.9032420>

- Imaz, M., & Sheinbaum, C. (2017). Science and technology in the framework of the sustainable development goals. *World Journal of Science, Technology and Sustainable Development*, 14(1), 2–17. <https://doi.org/10.1108/WJSTSD-04-2016-0030>
- Indiegogo. (2022). *REBO smart bottle—Clean the planet as you drink*. Indiegogo. <https://www.indiegogo.com/projects/2557912>
- Industrial Internet Consortium. (2019). *The Industrial Internet of Things Volume G1: Reference Architecture* (Version 1.9). Industrial Internet Consortium.
- ISACA. (2012). *Guide-cobit-5-isaca.pdf*.
- ISACA. (2018, December 4). *CMMI Institute Expands CMMI V2.0 to Include Services and Supplier Management*. ISACA. <https://www.isaca.org/en/why-isaca/about-us/newsroom/press-releases/2018/cmmi-institute-expands-cmmi-v2-to-include-services-and-supplier-management>
- ISO 9000:2005. (2005). *Quality management systems—Fundamentals and vocabulary*. International Organisation for Standardization, Geneva.
- ISO 14258:1998. (1998). *Industrial automation systems—Concepts and rules for enterprise models*. International Organisation for Standardization, Geneva.
- ISO 15704:2019. (2019). *Enterprise modelling and architecture—Requirements for enterprise-referencing architectures and methodologies*. International Organisation for Standardization, Geneva.
- ISO 15926-13:2018. (2018). *Industrial automation systems and integration—Integration of life-cycle data for process plants including oil and gas production facilities—Part 13:*

Integrated asset planning life-cycle. International Organisation for Standardization, Geneva.

ISO/FDIS 23247. (2021). *(Under development) Automation systems and integration—Digital twin framework for manufacturing—Part 1: Overview and general principles*. International Organisation for Standardization, Geneva.

ISO/IEC 2382:2015. (2015). *Information technology—Vocabulary*. International Organisation for Standardization, Geneva.

ISO/IEC 20924:2018. (2018). *Information technology—Internet of Things (IoT)—Vocabulary*. International Organisation for Standardization, Geneva.

ISO/IEC 20924:2021. (2021). *Information technology—Internet of Things (IoT)—Vocabulary*. International Organisation for Standardization, Geneva.

ISO/IEC 30141:2018. (2018). *Internet of Things (IoT)—Reference Architecture*. International Organisation for Standardization, Geneva.

ISO/IEC TR 30166:2020. (2020). *Internet of Things (IoT)—Industrial IoT*. International Organisation for Standardization, Geneva.

ISO/TR 24464:2020. (2020). *Automation systems and integration—Industrial data—Visualization elements of digital twins*. International Organisation for Standardization, Geneva.

ITU-T Y.4000/Y.2060. (2012). *Overview of the Internet of things*.

ITU-T Y.4003. (2018). *Overview of smart manufacturing in the context of the industrial Internet of things*.

- Janowicz, K., Haller, A., Cox, S. J. D., Le Phuoc, D., & Lefrançois, M. (2019). SOSA: A lightweight ontology for sensors, observations, samples, and actuators. *Journal of Web Semantics*, *56*, 1–10. <https://doi.org/10.1016/j.websem.2018.06.003>
- Kim, M., Lee, J., & Jeong, J. (2019). Open Source Based Industrial IoT Platforms for Smart Factory: Concept, Comparison and Challenges. In S. Misra, O. Gervasi, B. Murgante, E. Stankova, V. Korkhov, C. Torre, A. M. A. C. Rocha, D. Taniar, B. O. Apduhan, & E. Tarantino (Eds.), *Computational Science and Its Applications – ICCSA 2019* (Vol. 11624, pp. 105–120). Springer International Publishing. https://doi.org/10.1007/978-3-030-24311-1_8
- Kiritsis, D. (2011). Closed-loop PLM for intelligent products in the era of the Internet of things. *Computer-Aided Design*, *43*(5), 479–501. <https://doi.org/10.1016/j.cad.2010.03.002>
- Kritzinger, W., Karner, M., Traar, G., Henjes, J., & Sihn, W. (2018). Digital Twin in manufacturing: A categorical literature review and classification. *IFAC-PapersOnLine*, *51*(11), 1016–1022. <https://doi.org/10.1016/j.ifacol.2018.08.474>
- Le Moigne, J.-L. (1990). *La modélisation des systèmes complexes*. <https://www.dunod.com/sciences-humaines-et-sociales/modelisation-systemes-complexes>
- Lee, J., Bagheri, B., & Kao, H.-A. (2015). A Cyber-Physical Systems architecture for Industry 4.0-based manufacturing systems. *Manufacturing Letters*, *3*, 18–23. <https://doi.org/10.1016/j.mfglet.2014.12.001>
- Leng, J., Sha, W., Wang, B., Zheng, P., Zhuang, C., Liu, Q., Wuest, T., Mourtzis, D., & Wang, L. (2022). Industry 5.0: Prospect and retrospect. *Journal of Manufacturing Systems*, *65*, 279–295. <https://doi.org/10.1016/j.jmsy.2022.09.017>

- Li, S., Xu, L. D., & Zhao, S. (2015). The internet of things: A survey. *Information Systems Frontiers*, 17(2), 243–259. <https://doi.org/10.1007/s10796-014-9492-7>
- Lin, S.-W., Murphy, B., Clauer, E., Loewen, U., Neubert, R., Bachmann, G., Pai, M., & Hankel, M. (2017). Architecture Alignment and Interoperability: An Industrial Internet Consortium and Plattform Industrie 4.0 Joint Whitepaper. *Plattform Industrie 4.0*, 19.
- Liu, F., Tan, C.-W., Lim, E. T. K., & Choi, B. (2017). Traversing knowledge networks: An algorithmic historiography of extant literature on the Internet of Things (IoT). *Journal of Management Analytics*, 4(1), 3–34. <https://doi.org/10.1080/23270012.2016.1214540>
- Loison, F., Barrios, P., Danjou, C., & Eynard, B. (2020, November). Analyse Topologique des Structures de Données: Application à la Migration des Systèmes d'Information d'Entreprise. *13ème Conference Internationale De Modelisation, Optimisation et Simulation (MOSIM2020)*. MOSIM, AGADIR (virtuel), Morocco. <https://hal.archives-ouvertes.fr/hal-03177804>
- Lopez, J. V. V., Quatra, P., & Abbate, F. (2022). *Smart bottle* (World Intellectual Property Organization Patent WO2022033666A1). <https://patents.google.com/patent/WO2022033666A1>
- Madjar, I. (2017). *Cyclical Trends in PLM Is PLM Recycling Itself Over and Over?* | LinkedIn. <https://www.linkedin.com/pulse/cyclical-trends-plm-recycling-itself-over-ilan-madjar/>
- Mahut, F., Daaboul, J., Bricogne, M., & Eynard, B. (2017). Product-Service Systems for servitization of the automotive industry: A literature review. *International Journal of Production Research*, 55(7), 2102–2120. <https://doi.org/10.1080/00207543.2016.1252864>

- Masson-Delmotte, V., Zhai, P., Pirani, A., Connors, S. L., Péan, C., Berger, S., Caud, N., Chen, Y., Goldfarb, L., Gomis, M., & others. (2021). Climate change 2021: The physical science basis. *Contribution of Working Group I to the Sixth Assessment Report of the Intergovernmental Panel on Climate Change, 2*.
- McMeekin, N., Wu, O., Gemeni, E., & Briggs, A. (2020). How methodological frameworks are being developed: Evidence from a scoping review. *BMC Medical Research Methodology*, 20(1), 173. <https://doi.org/10.1186/s12874-020-01061-4>
- Meadows, D. H., & Club of Rome (Eds.). (1972). *The Limits to growth: A report for the Club of Rome's project on the predicament of mankind*. Universe Books. <https://www.clubofrome.org/publication/the-limits-to-growth/>
- Mehar, R. (2019). *Market Outlook: Product Lifecycle Management (PLM), 2019-2024, Worldwide*. Quadrant Knowledge Solutions Private Limited.
- Meier, U., Fischli, F., Sohrweide, A., & Nyffenegger, F. (2017). Twenty Years of PLM – the Good, the Bad and the Ugly. In J. Ríos, A. Bernard, A. Bouras, & S. Foufou (Eds.), *Product Lifecycle Management and the Industry of the Future* (Vol. 517, pp. 69–77). Springer International Publishing. https://doi.org/10.1007/978-3-319-72905-3_7
- Minerva, R., Biru, A., & Rotondi, D. (2015). Towards a definition of the Internet of Things (IoT). *IEEE Internet Initiative*, 1(1), 1–86.
- Miraz, M. H., Ali, M., Excell, P. S., & Picking, R. (2015). A review on Internet of Things (IoT), Internet of Everything (IoE) and Internet of Nano Things (IoNT). *2015 Internet Technologies and Applications (ITA)*, 219–224. <https://doi.org/10.1109/ITechA.2015.7317398>

- Monostori, L., Kádár, B., Bauernhansl, T., Kondoh, S., Kumara, S., Reinhart, G., Sauer, O., Schuh, G., Sihn, W., & Ueda, K. (2016). Cyber-physical systems in manufacturing. *CIRP Annals*, 65(2), 621–641. <https://doi.org/10.1016/j.cirp.2016.06.005>
- Ng, C. K., Wu, C. H., Yung, K. L., Ip, W. H., & Cheung, T. (2018). A semantic similarity analysis of Internet of Things. *Enterprise Information Systems*, 12(7), 820–855. <https://doi.org/10.1080/17517575.2018.1464666>
- Noran, O. (2003). *A Mapping of Individual Architecture Frameworks (GRAI, PERA, C4ISR, CIMOSA, ZACHMAN, ARIS) onto GERAM* (pp. 65–210). <https://doi.org/10.13140/RG.2.1.4315.8240>
- Nyffenegger, F., Hänggi, R., & Reisch, A. (2018). A Reference Model for PLM in the Area of Digitization. In P. Chiabert, A. Bouras, F. Noël, & J. Ríos (Eds.), *Product Lifecycle Management to Support Industry 4.0* (Vol. 540, pp. 358–366). Springer International Publishing. https://doi.org/10.1007/978-3-030-01614-2_33
- Omerali, M., & Kaya, T. (2021). Product lifecycle management application selection framework based on interval-valued spherical fuzzy COPRAS. *Journal of Intelligent & Fuzzy Systems*, 42(1), 425–438. <https://doi.org/10.3233/JIFS-219201>
- Paviot, T. (2010). *Méthodologie de résolution des problèmes d'interopérabilité dans le domaine du Product Lifecycle Management* (Issue 2010ECAP0018) [PhD Thesis, Ecole Centrale Paris]. <https://tel.archives-ouvertes.fr/tel-00504680>
- Pinquie, R., Rivest, L., Segonds, F., & Véron, P. (2015). An illustrated glossary of ambiguous PLM terms used in discrete manufacturing. *International Journal of Product Lifecycle Management*, 8(2), 142. <https://doi.org/10.1504/IJPLM.2015.070580>

- Pivoto, D. G. S., de Almeida, L. F. F., da Rosa Righi, R., Rodrigues, J. J. P. C., Lugli, A. B., & Alberti, A. M. (2021). Cyber-physical systems architectures for industrial internet of things applications in Industry 4.0: A literature review. *Journal of Manufacturing Systems*, 58, 176–192. <https://doi.org/10.1016/j.jmsy.2020.11.017>
- PTC. (2015). *PTC Windchill® Customization Guide*. 2110.
- PTC. (2022). *What Is PLM? | Product Lifecycle Management (PLM) | PTC*. <https://www.ptc.com/en/technologies/plm>
- Pun, L. (1979). Computer Assisted Static and Dynamical Plannings for Production Activities. *IFAC Proceedings Volumes*, 12(7), 431–439. [https://doi.org/10.1016/S1474-6670\(17\)65632-5](https://doi.org/10.1016/S1474-6670(17)65632-5)
- Quisbert-Trujillo, E., Ernst, T., Samuel, K. E., Cor, E., & Monnier, E. (2020). Lifecycle modeling for the eco design of the Internet of Things. *Procedia CIRP*, 90, 97–101. <https://doi.org/10.1016/j.procir.2020.02.120>
- Rangan, R. M., Rohde, S. M., Peak, R., Chadha, B., & Bliznakov, P. (2005). Streamlining Product Lifecycle Processes: A Survey of Product Lifecycle Management Implementations, Directions, and Challenges. *Journal of Computing and Information Science in Engineering*, 5(3), 227–237. <https://doi.org/10.1115/1.2031270>
- Rouibah, K., & Caskey, K. R. (2003). Change management in concurrent engineering from a parameter perspective. *Computers in Industry*, 50(1), 15–34. [https://doi.org/10.1016/S0166-3615\(02\)00138-0](https://doi.org/10.1016/S0166-3615(02)00138-0)

- Russell, L., Goubran, R., Kwamena, F., & Knoefel, F. (2018). Agile IoT for Critical Infrastructure Resilience: Cross-Modal Sensing As Part of a Situational Awareness Approach. *IEEE Internet of Things Journal*, 5(6), Article 6. <https://doi.org/10.1109/JIOT.2018.2818113>
- Saaksvuori, A., & Immonen, A. (2005). *Product lifecycle management*. Springer Science & Business Media. <https://doi.org/10.1007/b138258>
- Sabioni, R. C., Daaboul, J., & Le Duigou, J. (2021). Optimization of Reconfigurable Manufacturing Systems Configuration: A Literature Review. In L. Roucoules, M. Paredes, B. Eynard, P. Morer Camo, & C. Rizzi (Eds.), *Advances on Mechanics, Design Engineering and Manufacturing III* (pp. 426–435). Springer International Publishing. https://doi.org/10.1007/978-3-030-70566-4_67
- Santana, J., Barrios, P., & Eynard, B. (2021). Intégration d'objets connectés: Eléments d'aide au choix de plateforme IIoT. *CIGI QUALITA 2021: 14ème Congrès International de Génie Industriel et QUALITA*, 8.
- SAP. (2022). *What Is Product Lifecycle Management (PLM)?* SAP Insights. <https://insights.sap.com/what-is-product-lifecycle-management/>
- Schneider, S. (2016). The Industrial Internet of Things (IIoT): Applications and Taxonomy. In H. Geng (Ed.), *Internet of Things and Data Analytics Handbook* (pp. 41–81). John Wiley & Sons, Inc. <https://doi.org/10.1002/9781119173601.ch3>
- Schuh, G., Anderl, R., Dumitrescu, R., & Krüger, A. (2020). *Industrie 4.0 Maturity Index*. 64.

- Siemens. (2022). *PLM Software / Product Lifecycle Management Software*. Siemens Digital Industries Software. <https://www.plm.automation.siemens.com/global/en/our-story/glossary/product-lifecycle-management-plm-software/12506>
- Silventoinen, A., Pels, H. J., Kärkkäinen, H., & Lampela, H. (2011). Towards future PLM maturity assessment dimensions. *Proceedings of PLM11 8th International Conference on Product Lifecycle Management, 11th-13th July 2011, Eindhoven, the Netherlands*, 1–14.
- Personal Information Protection Law, (2021).
- Sudarsan, R., Fenves, S. J., Sriram, R. D., & Wang, F. (2005). A product information modeling framework for product lifecycle management. *Computer-Aided Design*, 37(13), 1399–1411. <https://doi.org/10.1016/j.cad.2005.02.010>
- Terzi, S., Bouras, A., Dutta, D., Garetti, M., & Kiritsis, D. (2010). Product lifecycle management—From its history to its new role. *International Journal of Product Lifecycle Management*, 4(4), 360. <https://doi.org/10.1504/IJPLM.2010.036489>
- Ullah, M., Nardelli, J., Molff, A., & Smolander, K. (2020). *Twenty-one key factors to choose an IoT platform: Theoretical framework and its applications* Mehar Ullah, Member, IEEE, Pedro Juliano Nardelli, Senior Member, IEEE, Annika Wolff, Kari Smolander. <https://arxiv.org/pdf/2004.04924.pdf>
- United Nations. (2016). *FCCC/CP/2015/10/Add.1*. 36.
- Vernadat, F. (1990). Modelling CIM enterprises with CIM-OSA. *Proceedings. Rensselaer's Second International Conference on Computer Integrated Manufacturing*, 236–243. <https://doi.org/10.1109/CIM.1990.128104>

- Vernadat, F. (2020). Enterprise modelling: Research review and outlook. *Computers in Industry*, 122, 103265. <https://doi.org/10.1016/j.compind.2020.103265>
- Walton, A. L. J., Grieves, M. W., Sandall, D. L., & Breault, M. L. (2016). Developing a Unified Product Lifecycle Management Value Model. In R. Harik, L. Rivest, A. Bernard, B. Eynard, & A. Bouras (Eds.), *Product Lifecycle Management for Digital Transformation of Industries* (Vol. 492, pp. 569–578). Springer International Publishing. https://doi.org/10.1007/978-3-319-54660-5_51
- Watson, R. A. (2021). Rene Descartes | Biography, Ideas, Philosophy, ‘I Think, Therefore I Am,’ & Facts. In *Encyclopedia Britannica*. <https://www.britannica.com/biography/Rene-Descartes>
- Weber, C., Königsberger, J., Kassner, L., & Mitschang, B. (2017). M2DDM – A Maturity Model for Data-Driven Manufacturing. *Procedia CIRP*, 63, 173–178. <https://doi.org/10.1016/j.procir.2017.03.309>
- Williams, T. J. (1994). The Purdue enterprise reference architecture. *Computers in Industry*, 24(2–3), 141–158. [https://doi.org/10.1016/0166-3615\(94\)90017-5](https://doi.org/10.1016/0166-3615(94)90017-5)
- World Economic Forum. (2015). *Industrial Internet of Things: Unleashing the Potential of Connected Products and Services*. World Economic Forum.
- Xu, L. D., He, W., & Li, S. (2014). Internet of Things in Industries: A Survey. *IEEE Transactions on Industrial Informatics*, 10(4), 2233–2243. <https://doi.org/10.1109/TII.2014.2300753>
- York, R., & McGee, J. A. (2016). Understanding the Jevons paradox. *Environmental Sociology*, 2(1), 77–87. <https://doi.org/10.1080/23251042.2015.1106060>

Zdravković, M., Trajanović, M., Sarraipa, J., Jardim-Gonçalves, R., Lezoche, M., Aubry, A., & Panetto, H. (2016). Survey of Internet-of-Things platforms. *6th International Conference on Information Society and Technology, ICIST 2016, 1*, 216–220. <https://hal.archives-ouvertes.fr/hal-01298141>

APPENDIX A DEFINITIONS OF IOT AND IIOT FROM STANDARDISATION BODIES

Please refer to full text for a contextualization of the definitions and associated comments. This is only provided for easiness of use, not completeness.

Reference	IoT definition	IIoT definition
(ITU-T Y.4000/Y.2060, 2012)	A global infrastructure for the information society, enabling advanced services by interconnecting (physical and virtual) things based on existing and evolving interoperable information and communication technologies.	-
(ITU-T Y.4003, 2018)	<i>Refers to the above</i>	An Internet of things based enabling approach for industrial transformation, by taking advantage of existing and emerging information and communication technologies.
IEEE IoT (Minerva et al., 2015)	[[key features listed]: interconnection of things, connection of things to the internet, uniquely identifiable things, ubiquity, sensing/actuation capability, embedded intelligence, interoperable communication capability, self-configurability & programmability.)	-
(IEEE 2413-2019, 2020)	A system of entities (including cyber-physical devices, information resources, and people) that exchange information and interact with the physical world by sensing, processing information, and actuating.	-
(ISO/IEC 20924, 2018 & 2021)	Infrastructure of interconnected entities, people, systems and information resources together with services, which processes and reacts to information from the physical world and the virtual world	-
(ISO/IEC TR 30166, 2020)	<i>Refers to the above</i>	IIoT is a new industrial ecosystem of service driven built based on the network interconnection, data interoperability and system interoperability of industrial resources, to realize the flexible configuration of the manufacturing materials, the on-demand execution of the manufacturing process, the rational optimization of the manufacturing process and the rapid adaptation of the manufacturing environment, and to achieve the efficient utilization of the resources.

APPENDIX B DEFINITIONS OF PLM AND PLM SOFTWARE

Reference	PLM definition	PLM software definition
(Terzi et al., 2010)	PLM can be broadly defined as a product centric – lifecycle-oriented business model, supported by ICT, in which product data are shared among actors, processes and organisations in the different phases of the product lifecycle for achieving desired performances and sustainability for the product and related services.	<i>No definition</i>
(Kiritsis, 2011)	Product Lifecycle Management (PLM) aims to manage the product related information efficiently during the whole product lifecycle. [...] PLM is a strategic approach and has three fundamental dimensions: (i) universal, secure, managed access and use of product definition information, (ii) maintaining the integrity of that product definition and related information throughout the life of the product or plant and (iii) managing and maintaining business processes used to create, manage, disseminate, share and use the information.	<i>No definition</i>
(PTC, 2022)	Product lifecycle management is the foundation for the digital thread, delivering supply chain agility and business continuity. Data governance and traceability provided by product lifecycle management enables organizations to drive down costs, accelerate time to market, and deliver the highest levels of quality and compliance.	Product lifecycle management software enables geographically dispersed, multi-disciplinary, teams to strategically collaborate with partners and customers using trusted, up-to-date product information.
Dassault Systèmes	<i>No definition</i>	<i>No definition</i>
(Siemens, 2022)	Product lifecycle management (PLM) is an information management system that integrates data, processes, business systems, and people in an extended enterprise.	PLM software allows to manage this information throughout the entire product lifecycle efficiently and cost-effectively: from ideation, design, and manufacture to service and disposal.
(SAP, 2022)	Product lifecycle management (PLM) is the process of managing a product's lifecycle from inception, through design and manufacturing, to sales, service, and eventually retirement.	As a technology, PLM software helps organizations to develop new products and bring them to market. The software makes it easy to track and share data along the product value chain, from initial design through manufacturing, supply chain management and operations, and asset maintenance.

