



**HAL**  
open science

# A conceptual and holistic approach to reliability modeling of complex systems

Virag Wasnik

► **To cite this version:**

Virag Wasnik. A conceptual and holistic approach to reliability modeling of complex systems. Other. Université de Toulouse, 2024. English. NNT : 2024TLSEP154 . tel-04950967

**HAL Id: tel-04950967**

**<https://theses.hal.science/tel-04950967v1>**

Submitted on 17 Feb 2025

**HAL** is a multi-disciplinary open access archive for the deposit and dissemination of scientific research documents, whether they are published or not. The documents may come from teaching and research institutions in France or abroad, or from public or private research centers.

L'archive ouverte pluridisciplinaire **HAL**, est destinée au dépôt et à la diffusion de documents scientifiques de niveau recherche, publiés ou non, émanant des établissements d'enseignement et de recherche français ou étrangers, des laboratoires publics ou privés.

# Doctorat de l'Université de Toulouse

préparé à Toulouse INP

---

Approche conceptuelle et holistique de la modélisation de la  
fiabilité des systèmes complexes

---

Thèse présentée et soutenue, le 20 décembre 2024 par

**Virag WASNIK**

**École doctorale**

SYSTEMES

**Spécialité**

Génie Industriel

**Unité de recherche**

LGP - Laboratoire Génie de Production

**Thèse dirigée par**

François PERES et Ayeley TCHANGANI

**Composition du jury**

M. Benoît IUNG, Président, Université de Lorraine

M. Ali SIADAT, Rapporteur, Metz Arts et Métiers

M. Lyes BENYOUCEF, Rapporteur, Aix-Marseille Université

M. Daouda KAMISSOKO, Examineur, IMT Mines Albi

Mme Carmen MARTIN, Examinatrice, UTTOP

M. François PERES, Directeur de thèse, UTTOP

**Membres invités**

M. Ayeley TCHANGANI, UTTOP



## Acknowledgements

First and foremost, I would like to express my deepest gratitude to my supervisor, **Pr. PERES François**, for his unwavering support, insightful guidance, and patience throughout the course of this research. His expertise and mentorship have been instrumental in shaping the direction and depth of this work.

I would also like to extend my heartfelt thanks to **Ayeley Tchangani** and **MARTIN Carmen**, whose invaluable advice and encouragement have greatly contributed to the development of this thesis. Your insights have been crucial to navigating the challenges of this research, and I am immensely grateful for your support.

I am deeply appreciative of the **University of Toulouse** and the **Production Engineering Laboratory (LGP-ENIT)** for providing the resources and an intellectually stimulating environment that made this work possible. Your support and facilities have been indispensable in the completion of this research.

I owe my deepest gratitude to **Dr. Babasaheb Ambedkar**, whose transformative work for social justice and equality has made it possible for me to pursue higher education. His tireless efforts to break down barriers and uplift marginalized communities have opened doors for individuals like me, allowing us access to opportunities that were once out of reach. His legacy continues to inspire me every day, and I am profoundly indebted to his vision and leadership.

Finally, to my **father, mother, and my supportive sister and Mona Memarzadeh** your endless love, encouragement, and unwavering belief in my abilities have been my greatest source of strength. Without your sacrifices and support, none of this would have been possible. I dedicate this achievement to you.

**"To all who have supported me on this journey, your impact has been profound, and I carry your contributions with me as I step into the future."**

*Thank you.*

## Abstract

The study envisaged is placed in a conceptual context of a multidimensional assessment of the reliability of a complex mechatronic architecture system. More specifically, the aim is to develop an innovative methodological framework that breaks with conventional techniques for assessing the probability of failure of a system. Unlike traditional approaches based on the principles of calculating reliability by progressively feeding back composite information derived from the combination of reliability measurements of elementary components, the methodology under consideration is bi-univocal. Using a matrix approach, the proposal described below relates the functional and dysfunctional states of the strata to represent the different levels of decomposition of a complete system down to its basic components.

The proposed methodology is based on the evidence that failures always occur at the level of the most elementary components but originate and propagate their effects at higher levels. The failure of an elementary component can be caused by:

- a cause external to the system, applied to the component and placing it outside its nominal operating range and therefore resistance.
- a lack of intrinsic quality, linked to a design or manufacturing defect in the component, making it incapable of performing the required function.
- a level of stress in excess of the permissible load, induced by the subsystem within which it operates.
- a number of stresses exceeding a limit threshold, triggering a malfunction due to fatigue.

Excluding quality problems, which are factors in malfunctions not addressed in this work, the process of modelling the reliability of a system therefore requires a multidimensional approach linking the different hierarchical levels of the system under study. This approach cannot be purely multi-scale and, while the reliability model must consider both the spatial dimension (the place of the entity in the system nomenclature), it must also take into account the temporal dimension (the rate and form of stress and the dynamics of failure occurrence). This spatio-temporal representation of a system's reliability behaviour requires a combination of several views. This thesis focuses on characterising these different views and integrating them into a single methodological framework.

# Table of Contents

<b>Abstract</b> .....	4
<b>1.1 Background and Motivation for Multiscale Modelling in Complex System</b> .....	1
1.1.1 Understanding Complex Systems .....	3
1.1.2 Multiscale Modelling in Complex Systems .....	5
1.1.3 Holistic Approach in Multiscale Modelling.....	6
1.1.4 Multiview Perspectives .....	8
<b>1.2 Overview of the 'U-cycle approach' and its Relevance to Dysfunctional Modelling</b> .....	8
<b>1.3 Aim and Scope of the Thesis</b> .....	11
<b>1.4 Research questions and hypotheses</b> .....	13
<b>2.1 Introduction to Structural View</b> .....	20
<b>2.2 Relevant theoretical framework</b> .....	22
2.2.1 Historical perspective.....	22
2.2.2 Comprehensive review of existing literature .....	23
2.2.3 Discussion of different modelling principles .....	26
2.2.4 Critical analysis of relevant articles .....	30
<b>2.3 Methodology for structural view analysis</b> .....	32
<b>2.5 Application of Structural View to Multiscale Modelling</b> .....	38
2.5.1 Multiscale modelling for hierarchical stress analysis in complex engineering system ....	38
2.5.2 Integrative Approach for Diagnostic and Prognostic Systems through Structural Modelling .....	40
<b>2.6 Conclusion</b> .....	42
<b>3.1 Introduction to Temporal</b> .....	45
3.1.1 Temporal View .....	46
3.2.1 Understanding System Reliability through a Holistic Approach.....	52
3.2.2 Incorporating the Temporal Dimension .....	52
3.2.3 Enhancing System Reliability .....	52
<b>3.3 Overlay of temporal view in U-cycle approach</b> .....	53
<b>3.4 Conclusion</b> .....	56
<b>4.1 Physical View</b> .....	58
4.1.1 Physical view Multiscale Modelling.....	59
<b>4.2 Overlay of the Physical view in U-cycle approach</b> .....	59

4.2.1 Analysing the Impact of Mission Profiles on System Stresses .....	61
4.2.2 Transition of Mission Profiles Across Hierarchical Levels .....	62
<b>4.3 Physical constraints and their induction .....</b>	<b>63</b>
4.3.1 Propagation of Effects.....	64
<b>4.4 Modelling Framework.....</b>	<b>65</b>
4.4.1 Modelling the physical view .....	65
4.4.2 Characterisation of induced physical phenomena.....	67
<b>4.5 Deterministic Framework .....</b>	<b>67</b>
4.5.1 Bond Graphs: A Standardized Approach to Multi-Physical Components.....	68
4.5.2 System Dynamics: Modelling Temporal Evolution of Physical Phenomena .....	69
4.5.3 Why the Deterministic Framework is Critical .....	69
<b>4.6 Stochastic Framework .....</b>	<b>70</b>
4.6.1 Failure Modes and Effects Analysis (FMEA): Addressing System Failures in Uncertainty	71
4.6.2 Hazard and Operability Study (HAZOP): Ensuring Safety under Uncertainty .....	72
4.6.3 Petri Net Method: Modeling Complex Interactions and System Dynamics .....	73
4.6.4 Why the Stochastic Framework is Essential .....	73
<b>4.7 (Spot 3'): Identification of failure mechanisms and resulting damage .....</b>	<b>75</b>
<b>4.8 Conclusion .....</b>	<b>77</b>
<b>5.1 Introduction to Logical view .....</b>	<b>81</b>
<b>5.2 Logical view .....</b>	<b>82</b>
<b>5.3 Aim of the Work.....</b>	<b>84</b>
<b>5.4 Reliability Block Diagram (RBD) for System Reliability .....</b>	<b>86</b>
5.4.1 Introduction to Reliability Block Diagrams (RBD).....	86
5.4.1.1 <i>Why Use RBD in System Reliability Analysis?</i> .....	87
5.4.1.2 <i>The Logical Framework for Series, Parallel, and Hybrid Configurations</i> .....	88
5.4.2 Series Configuration: Understanding Vulnerability and Improving Resilience .....	89
5.4.2.1 <i>Challenges in Series Configuration</i> .....	89
5.4.3 Parallel Configuration: Leveraging Redundancy for Higher Reliability .....	90
5.4.3.1 <i>Innovative Solutions and Research Approach</i> .....	91
5.4.4 Reliability Block Diagram (RBD) of Hybrid Configuration .....	91
5.4.4.1 <i>Explanation of Hybrid Configurations with Conditional Dependencies</i> .....	92
5.4.4.2 <i>Challenges in Representing Complex Systems with Diagrams</i> .....	95
5.4.4.3 <i>Application to Our System</i> .....	96
5.4.5 Key Concepts and Mechanisms Behind Failure-to-Working Switches.....	96
<b>5.5 Fault tree analysis in system reliability .....</b>	<b>99</b>

5.5.1 What is Fault Tree Analysis (FTA).....	99
5.5.2 Why Use FTA in System Reliability?.....	100
5.5.3 Fault Tree Analysis (FTA) in System Reliability .....	101
5.5.4 Defining Overall System Reliability Using FTA.....	102
5.5.5 FTA’s Role in Enhancing System Reliability .....	102
<b>5.6 Validation and verification of the logical view .....</b>	<b>103</b>
<b>5.6 Conclusion .....</b>	<b>106</b>
<b>6.1 Introduction to U-cycle approach in multiscale modelling .....</b>	<b>110</b>
<b>6.2 Tool specification for instrumenting U-Cycle approach .....</b>	<b>110</b>
6.2.1 Parameters for U-Cycle implementation.....	110
6.2.2 Frameworks and Tools for System Reliability Analysis Across Different Views .....	114
<b>6.3 Unifying modelling approach .....</b>	<b>116</b>
6.3.1 Discussion on tools .....	116
6.3.1.1 <i>Neutral network</i> .....	116
6.3.1.2 <i>Bayesian network</i> .....	118
6.3.1.3 <i>Rational for tools selection</i> .....	121
<b>6.4 Case study: Application for U-cycle in a complex system .....</b>	<b>123</b>
6.4.1 System description .....	123
6.4.2.1 <i>Structural view</i> .....	124
6.4.2.2 <i>Temporal view</i> .....	126
6.4.2.3 <i>Physical View</i> .....	129
6.4.2.4 <i>Logical view</i> .....	133
<b>6.5: Future Perspectives &amp; Research Direction .....</b>	<b>137</b>
<b>Conclusion .....</b>	<b>139</b>
<b>Critical analysis and prospects .....</b>	<b>139</b>
<b>Bibliography .....</b>	<b>143</b>



# List of Figures

<i>Figure 1. Complex system hierarchy</i> .....	4
<i>Figure 2. Proposed U-cycle approach</i> .....	9
<i>Figure 3 Structural breakdown</i> .....	24
<i>Figure 4. An Example of causal modelling</i> .....	28
<i>Figure 5. Multiscale modelling approach</i> .....	29
<i>Figure 6. U-Cycle Approach</i> .....	33
<i>Figure 7. Structural breakdown for modelling approach</i> .....	36
<i>Figure 8. Structural hierarchy of an autonomous vehicle system</i> .....	37
<i>Figure 9. Design approach to health management</i> . .....	41
<i>Figure 10. Time-dependent system profile</i> .....	47
<i>Figure 11. Spatial-temporal multiscale modelling (Wang et al., 2023)</i> .....	51
<i>Figure 12. Superimposition of Temporal view (Spot 2)</i> .....	53
<i>Figure 13. Typical example of mission profile of aircraft</i> .....	55
<i>Figure 14. Overlay of Physical view (Spot 3)</i> .....	61
<i>Figure 15. Inferred physical phenomena</i> . .....	64
<i>Figure 16. Example of bond graph representing electrical circuit</i> .....	69
<i>Figure 17. Failure Modes and Effects Analysis (FMEA) Process (cited from(Ardeshirtanha &amp; Sharafati, 2020)</i> .....	72
<i>Figure 18. Example of Petri net (Volvoi, 2004)</i> .....	73
<i>Figure 19. Overlay of Physical view (Spot 3')</i> .....	77
<i>Figure 20. Example of a reliability block diagram of a redundant architecture</i> .....	83
<i>Figure 21 Reliability block diagram</i> .....	87
<i>Figure 22. System Subsystems Configuration Diagram</i> .....	89
<i>Figure 23 Series configuration</i> .....	89
<i>Figure 24 Parallel configuration for reliability</i> .....	91
<i>Figure 25. Hybrid System Configuration with Critical Component M3</i> .....	92
<i>Figure 26. Case with M3 is Faulty</i> .....	94
<i>Figure 27. Redundant System with Standby Components for Failure-to-Working Switching</i> .....	97
<i>Figure 28. Fault tree Analysis</i> .....	100
<i>Figure 29. Spot 4 U-cycle approach</i> .....	104
<i>Figure 30. Model of neuron</i> .....	118
<i>Figure 31 Neural network (Bouhamed et al., 2015)</i> .....	118
<i>Figure 32. Bayesian network</i> .....	121
<i>Figure 33. Electric Aircraft</i> .....	124
<i>Figure 34. Case study structural breakdown</i> .....	125

<i>Figure 35. Control aircraft flaps electro hydrostatic actuator .....</i>	128
<i>Figure 36. Converter architecture .....</i>	128
<i>Figure 37. Bayesian network representation for structural and temporal view .....</i>	129
<i>Figure 38. Bayesian network dynamic node .....</i>	129
<i>Figure 39. Bayesian network representing the structural, temporal and physical views .....</i>	130
<i>Figure 40. Example of component failure physical process modelling .....</i>	132
<i>Figure 41. Simplified architecture of the electrical network of a 300- passenger "2H2E" aircraft (adapted from (Langlois et al., 2006)).....</i>	133
<i>Figure 42. Three-phase inverter with parallelised cells two by two with decoupling inductors and insulation switches .....</i>	134
<i>Figure 43. Block reliability diagram of function F6 .....</i>	135
<i>Figure 44. Bayesian network representing the structural, temporal, physical and logical views ..</i>	136

# List of Abbreviations

**AI:** Artificial Intelligence

**ML:** Machine Learning

**BN:** Bayesian Network

**PdM:** Predictive Maintenance

**FTA:** Fault Tree Analysis

**SIL:** Safety Integrity Level

**CFDS:** Central Fault Display System

**LRU:** Line-Replaceable Unit

**UAV:** Unmanned Aerial Vehicle

**NN:** Neural Network

**DAG:** Directed Acyclic Graph

**TLE:** Top-Level Event

**DBN:** Dynamic Bayesian Network

**RUL:** Remaining Useful Life

**ANNs:** Artificial Neural Networks

**HAZOP:** Hazard and Operability Study

**RBD:** Reliability Block Diagram

**FMECA:** Failure Mode, Effects, and Criticality Analysis

**FMEA:** Failure Mode and Effects Analysis

**DRBD:** Dynamic Reliability Block Diagram

**SCADA:** Supervisory Control and Data Acquisition

**UAV:** Unmanned Aerial Vehicle

**RAMS:** Reliability, Availability, Maintainability, Safety



# **Chapter I**

## **Introduction**

## 1.1 Background and Motivation for Multiscale Modelling in Complex System

In the contemporary landscape of engineering and technology, complex systems have become ubiquitous, permeating diverse domains such as transportation, healthcare, energy, and communication (Smith et al., 2019; Jones & Brown, 2021). These intricate systems, comprised of interconnected components and subsystems, exhibit emergent properties that challenge traditional reliability modelling methodologies. This thesis embarks on a journey to unravel the intricacies of complex systems through a conceptual and holistic approach, with a specific focus on multiscale and multiview modelling for enhanced reliability analysis.

There is no need to recall the significant importance of the confidence that a consumer or client wishes to have in the use, exploitation or consumption of a product or in the performance of a service. The occurrence of a failure, a defect, an error or the appearance of a non-conformity is likely to call this trust into question if the quality of the expected performance deteriorates too rapidly. Beyond a certain threshold of deterioration, this is referred to as a loss of reliability. In this thesis, while the field of transport is highlighted as a prime example, the underlying principles and challenges of reliability control are by no means confined to this domain alone. The choice to initially focus on transportation stems from its illustrative complexity and the clear impact that reliability has on safety, efficiency, and competitiveness within this sector. However, the methodologies and insights developed are intended to have broad applicability, addressing the emergent properties of complex systems across diverse fields such as healthcare, energy, and communication systems. Each of these domains, similar to transportation, faces its own set of unique challenges in reliability and system performance, making the exploration of multiscale and multiview modelling techniques universally relevant and critically important.

- A growing number of sensitive electronic components in systems (aircraft, trains, cars etc.), infrastructures, communicating devices, etc.
- An increase in customer requirements regarding both the robustness of products and systems as well as the methodological demonstration by suppliers of the achievement of the objectives set in this regard,
- The increasing severity of standards and regulations (Safety Integrated Levels or SIL).
- This results in concerns regarding operational reliability and the overall prediction of failure probabilities of system or component.

The ability to assess reliability in this field is more crucial because the operational reliability of electronic systems remains an open research issue, and to date, very little work has undertaken to this topic in a system engineering framework. To compensate for this lack, the study reported in this thesis is placed in a conceptual context of a multiscale reliability assessment of a complex mechatronic architecture system. More precisely, the work presented here is part of an innovative methodological framework, breaking with the classical techniques of evaluation of the probability of failure of a system. Contrary to traditional approaches based on the principles of reliability calculation by

progressive feedback of composite information resulting from the combination of reliability measurements of elementary components, the methodology considered is built on the concept of a one-to-one relationship. In a matrix approach, the proposal described below relates the functional and dysfunctional levels of the different layers leading from a complete system to its basic components. We will present a generic approach from a theoretical point of view. The general concepts for constructing the global matrix view will be stated. The choice of practical tools capable of supporting this conceptual representation will then be discussed.

In recent years, multiscale modelling has emerged as a transformative approach to the simulation of complex systems, spanning a wide range of scientific disciplines from material sciences to social systems. This approach is instrumental in addressing the intricacies inherent in complex systems, where phenomena unfold across multiple scales and can be significantly influenced by factors ranging from atomic interactions to macroscale dynamics (H. Wang *et al.*, 2023). Complex engineering systems encompass a range of physical processes that occur at molecular, microscopic, and macroscopic levels. Multiscale modelling provides a framework for integrating these different scales to ensure the successful design and operation of such systems.

Multiscale modelling provides a framework to capture the detailed behaviour of these complex systems by linking different scales. For instance, in fluid mechanics, which is relevant to both aeronautics and thermodynamics in trains, multiscale modelling helps to predict complex flow phenomena by bridging the gap between the molecular interactions and the flow behaviour at the macroscopic level. In the context of materials science, understanding the microstructural properties of materials is essential for predicting the performance of the material in an engineering component or a system.

However, the challenge lies in the computationally intensive nature of solving multiscale problems due to the high dimensionality of the solution space. Machine learning has emerged as a promising tool to overcome these challenges, potentially serving as a surrogate for traditional numerical methods, offering faster computational speeds, and providing a better initial solution for traditional solvers. Machine learning also facilitates the reduction of dynamical variables and parameters while maintaining the relevance and fidelity of the models, thus offering a new pathway to solve complex multiscale problems more efficiently. (Nguyen *et al.*, 2023).

One of the main motivations for adopting multiscale modelling in complex systems is its ability to integrate knowledge and data from different scales to provide a more comprehensive understanding of system behaviours. This not only helps to accurately predict system outcomes but also facilitates a deeper exploration of the underlying mechanisms across scales. For example, in the realm of biological and biomedical sciences, multiscale modelling can synergise with machine learning to teach the algorithms the physics of biological systems, thereby improving the predictive insights into these systems. In turn, machine learning can refine multiscale models by identifying optimal parameter values and system dynamics, improve our understanding of phenomena such as cardiac function (Alber *et al.*, 2019a). The background to multiscale modelling is motivated by the need to address systems where data might be incomplete, and the governing physical laws are not fully elucidated. The integration of machine learning into multiscale modelling provides a robust

framework for learning from such incomplete and noisy datasets, by imposing physics-based constraints that guide the learning process. This integration is not without its challenges, as it is requiring novel approaches to deal with the complexity and uncertainty inherent in such systems. Nevertheless, the potential for transformative insights makes multiscale modelling a highly motivating field of study, with significant implications for advancing our understanding and control of complex systems (Alber *et al.*, 2019a).

The incorporation of machine learning into multiscale modelling, especially in domains such as biological and biomedical sciences and complex engineering systems, heralds a new era of possibilities for understanding and predicting system behaviors in dynamic environments. Machine learning techniques, ranging from regression models to neural networks, enable researchers to develop robust surrogate models capable of learning from small and noisy datasets. These models are not limited to a single approach; they encompass a variety of methods designed to harness the vast potential of data-driven insights. By leveraging the underlying physics of the systems, these approaches can significantly constrain design spaces and enhance the fidelity of simulations. This integration of machine learning with physics-based modeling ensures that the simulations remain grounded in the fundamental principles of the systems under study, facilitating more accurate and reliable predictions (Alber *et al.*, 2019).

Recent advances have shown that by integrating machine learning with multiscale modelling, we can exploit the strengths of both approaches. Machine learning can help identify parameter values and system dynamics, while multiscale modelling can teach machine learning on how to exploit the underlying physics, thereby enriching the learning process with domain-specific knowledge. This integration is particularly important in engineering where the systems under study are complex and the data are often incomplete or noisy. The coupling of data and physics-based models through machine learning can impose the necessary constraints to ensure that the predictive models remain robust and reliable (Alber *et al.*, 2019a). Multiscale modelling in complex systems stems from the need to address with the multifaceted nature of these systems. The approach aims to go beyond traditional modelling techniques by exploiting the strengths of both knowledge-based and data-driven methods to gain a holistic view of system behaviours, which is crucial for advancing scientific understanding and technological progress.

### 1.1.1 Understanding Complex Systems

Complex systems are marked by non-linear interactions, feedback loops, and dependencies, which make their behavior challenging to predict and manage. A holistic perspective on these systems emphasizes the interactions of components, underscoring the need for robust modeling to capture their dynamic nature (Smith *et al.*, 2019; Jones & Brown, 2021). By grasping the architecture and functionality of complex systems, we can improve reliability analysis. Typically, complex systems are composed of multiple physical levels—system, subsystem, and component—each responsible for specific functions and interconnected to form the whole. Understanding these interactions is vital for designing, analyzing, and optimizing system performance.



## Introduction

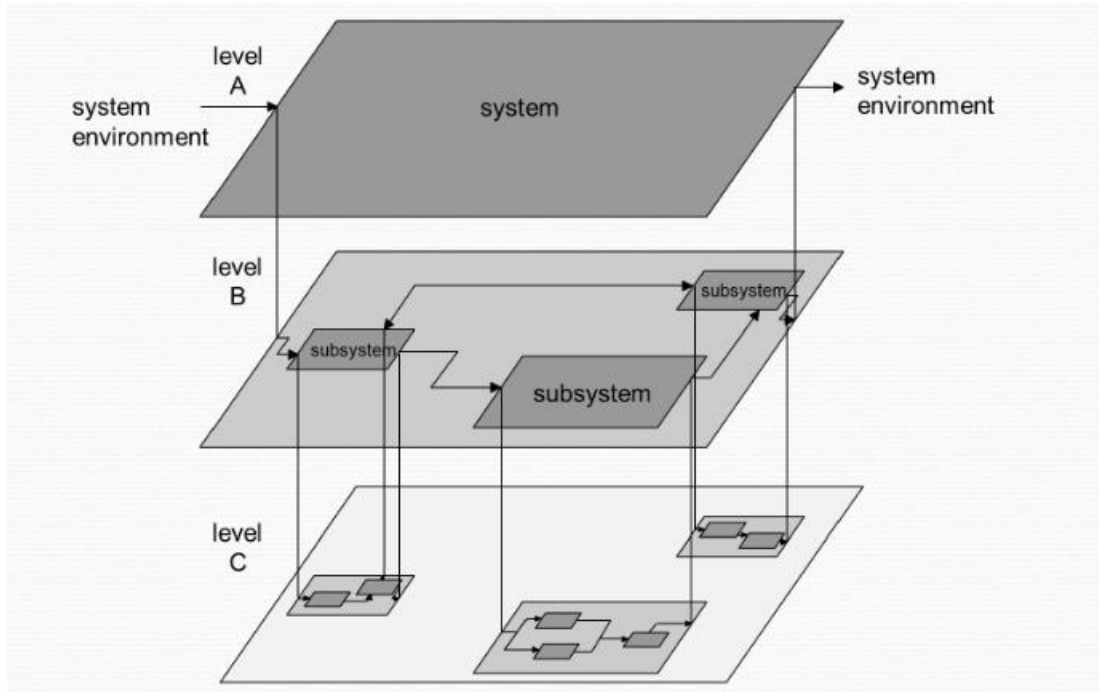

*Figure 1. Complex system hierarchy.*

This phenomenon is widely recognised and extensively studied in various fields of engineering and science. The concept of the "domino effect" is often used to describe the propagation of failures from one level to another in a system, and it highlights the importance of understanding the failure mechanisms at the most fundamental level. In many cases, the failure of an elementary component can be difficult to detect until it has already propagated to higher levels, making it critical to implement robust monitoring and maintenance procedures to ensure the early detection and mitigation of potential failures. By studying the propagation of failures and their origins at the elementary level, engineers and scientists can design more reliable and resilient systems, and ultimately minimise the risk of catastrophic events.

The study on learning about complex systems highlights the need to integrate different theoretical frameworks and methodologies across disciplines to improve understanding. These include complexity science, structure-behaviour-function theory, conceptual change, knowledge integration, and self-regulated learning. Emphasising the importance of using mixed methods to gather and analyse both qualitative and quantitative data, the comprehensive approach to evidence collection to understand the comprehension of complex systems fully (Hmelo-Silver and Azevedo, 2006). Key to this research is exploration of different types of study, assessing their strengths and weaknesses, and considering their implications for industrial practice and research methodology. This research highlights the intricate relationship between theoretical foundations and empirical investigations in advancing our understanding of learning in complex systems.

The study of complex systems science reveals significant challenges that span the fields of data analysis, model calibration, and dynamical model development. These challenges underscore the intricate balance required between exploiting the richness of data and striving for model simplicity (San Miguel *et al.*, 2012). A critical issue is the unpredictability of system behaviour, arising from sensitivity to initial conditions and the emergence of novel phenomena. This unpredictability is compounded by the need to integrate different scales of analysis and types of data, further complicating the modelling process. In addition, the study of socio-technical systems highlights the dynamic interplay between technological progress and human behaviour, which is crucial for understanding the wider implications for societal and environmental sustainability. (San Miguel *et al.*, 2012).

### 1.1.2 Multiscale Modelling in Complex Systems

Multiscale modelling in complex engineering systems refers to a computational modelling approach that integrates phenomena at multiple scales, from the atomic or molecular levels up to the macroscopic level of materials and structures. This approach is crucial for understanding and predicting the behaviour of complex systems across different scales of size and time, which is particularly important in fields such as materials science, mechanical engineering, chemical engineering, and biomedical engineering. The primary goal of multiscale modelling is to bridge the gap between detailed, lower-level descriptions of systems (such as quantum mechanics or molecular dynamics at the atomic and molecular levels) and coarser-grained, higher-level descriptions (such as continuum mechanics at the macroscopic level). This approach allows engineers and scientists to capture the essential physics and chemistry that occur at small scales, and how these microscopic interactions affect the behaviour and performance of materials and systems at larger scales (Kovachki *et al.*, 2022).

A key aspect of our investigation revolves around multiscale modelling, a technique that allows us the capture of phenomena occurring at multiple levels of granularity. Traditional reliability models often fail to account for the heterogeneity present in complex systems. Multiscale modelling, as proposed by (O'Reilly & Munakata 2020) and extended by (Wang *et al.* 2022), provides a nuanced approach to incorporate different scales, ensuring a more accurate representation of the system dynamics. Multiscale modelling in complex engineering systems not only addresses the hierarchical and multiscale nature of these systems, but also helps bridging phenomena across spatial and temporal scales. This approach is crucial in chemical engineering, where it enables the integration of processes from the molecular level to the macroscopic scale, thus facilitating the design and optimisation of more efficient, sustainable processes and technologies. The key challenge in multiscale modelling is to capture the dynamics of complex systems characterised by nonlinear and non-equilibrium interactions, dissipative structures, and the need for a trade-off between different dominant mechanisms across scales. This methodology requires not only a deep understanding of the interactions within each scale but also how these interactions influence behaviours across scales. By using multiscale modelling, engineers and scientists can better predict system behaviours, design more effective solutions to engineering challenges, and contribute to the advancement of technologies in various fields, including chemical processing, materials science, and environmental engineering. (Li *et al.*, 2004)

A notable aspect discussed is the compromise between different dominant mechanisms within a system, which is essential for the emergence of stable and ordered structures. This compromise, which involves both spatial and temporal dimensions, underlies the nonlinear and non-equilibrium nature of complex systems. By resolving and analyzing these compromises, multiscale modelling enables the prediction and manipulation of the behaviour of complex engineering systems in ways that were previously unattainable. (Li *et al.*, 2004)

Multiscale modelling typically involves several steps, including the selection of appropriate models for each scale, the development of algorithms to link these models, and the integration of data and simulations across scales. This process requires sophisticated mathematical and computational techniques, including homogenisation theory, coarse-graining methods, and coupling algorithms (Karabasov *et al.*, 2014). A key challenge in multiscale modelling is the development of efficient and accurate methods for coupling different scales, which often have very different physical laws and computational requirements. Another challenge is the computational cost, as simulations at the atomic or molecular level can be extremely resource-intensive (*Multiscale Modeling - an overview / ScienceDirect Topics*, 2024). Multiscale modelling is a powerful approach to understanding and predicting the behaviour of complex engineering systems across different scales. By integrating detailed microscopic descriptions with macroscopic models, engineers and scientists can gain insights into the fundamental mechanisms that drive performance and behaviour of materials and systems, leading to innovations in design, materials science, and technology (Tadmor and Miller, 2011).

### 1.1.3 Holistic Approach in Multiscale Modelling

The holistic approach of multiscale modelling integrates different scales of analysis, from the microscopic to the macroscopic, to better understand and predict the behaviour of complex systems. This approach is critical in fields such as biology, biomedicine sciences, and engineering, where phenomena at one scale are significantly influenced by processes at other scales. One key aspect of this approach is the integration of machine learning with physics-based models to improve multiscale modelling. Machine learning can process vast amounts of data to identify patterns and correlations, while physics-based models provide the underlying mechanisms that govern system behaviours. For example, partial differential equations, which encode physics-based knowledge, can be integrated with machine learning to improve model robustness and predictive capabilities, especially when dealing with small and noisy data sets (Wang and Bianco, 2021).

In addition, theory-driven machine learning integrates physics-based ordinary or partial differential equations into the machine learning pipeline, using structured physical laws and mechanistic models as informative priors. This integration accelerates multiscale simulations and advances modelling capabilities, allowing for the seamless incorporation of physics-based models across multiple spatial and temporal scales. Such approaches are essential for understanding complex biological systems and developing personalised medicine, as they enable the creation of digital twins—detailed multiscale models of organ systems or disease processes for therapy development without risk to the patient (Wang and Bianco, 2021).

In essence, a holistic approach to multiscale modelling enables a deeper understanding of complex systems by bridging the gap between data-driven machine learning and theory-driven physics. This synergy not only improves predictive modelling but also opens new avenues for research and development across various scientific and engineering disciplines. A holistic approach to multiscale modelling involves integrating different scales of a system to provide a comprehensive understanding and analysis. Here are some insights to understand the holistic approach:

- **Hydrological Modelling:** In the context of hydrology, a holistic modelling approach aims to find a single set of parameters for a hydrological model that is valid for the entire domain (Willkofer *et al.*, 2020). This method is used to estimate the return levels of peak flows in specific regions such as Bavaria.
- **Production Systems:** The application of a comprehensive and holistic approach in multiscale modelling and simulation is crucial for understanding and optimising manufacturing systems (Constantinescu *et al.*, 2018). This approach allows for a detailed analysis of manufacturing processes at different scales.
- **Biological systems:** Multiscale modelling in biological systems involves analysing the behavior of the whole system to generate hypotheses and explore system components (Millar-Wilson *et al.*, 2022). This method helps to understand complex biological interactions.
- **Environmental health risk assessment:** A multiscale approach is used to assess interactions between environmental and biological systems in holistic health risk assessments (Georgopoulos, 2007). This framework considers simultaneous exposures to different environmental factors for a person-centred assessment.

There are several advantages to using a holistic approach in multiscale modelling in different areas.

- **Comprehensive understanding:** A holistic approach allows the analysis of the behaviour of the whole system, the generation of hypotheses, and the exploration of system components (Millar-Wilson *et al.*, 2022). This method provides a deeper profound understanding of complex systems, such as biological systems.
- **Optimisation of systems:** In manufacturing systems, a comprehensive and holistic approach in multiscale modelling enables for a detailed analysis and optimisation of manufacturing processes (Constantinescu *et al.*, 2018). By considering multiple scales simultaneously, this approach improves system efficiency and performance.
- **Improved sampling and diversity:** Pairwise coupling of different scales in multiscale modelling enhances sampling and diversity, leading to more robust models (Ingólfsson *et al.*, 2023). This approach ensures that each scale complements the other, improving the overall accuracy and reliability of the models.
- **Mechanism-based assessments:** In health risk assessment, a multiscale approach enables mechanism-based evaluations in a person-centred framework, considering simultaneous exposures to environmental factors (Georgopoulos, 2007). This method provides a more accurate assessment of health risks by integrating different scales of exposure.

### 1.1.4 Multiview Perspectives

To further enrich our understanding, this thesis adopts a multi-view perspective. Complex systems can be viewed from different perspective, each of which sheds light on specific aspects of their behaviour. By integrating multiview modelling (Chen & Liu, 2018), we aim to develop a comprehensive framework that considers not only the overall system architecture but also the individual subsystems, thereby capturing the nuances of system reliability from different perspective. By addressing into the intricacies of conceptual and holistic modeling for complex systems, this work aims to contribute to the evolving field of reliability analysis. By synthesising of multiscale and multiview approaches, we aim at improving a robust methodology for assessing and enhancing the reliability of complex systems in diverse real-world applications.

Building on the observations made in the previous paragraphs, wherein the performance of a component are characterised not only by those related to the component itself but also by those associated with the system in which it operates. This representation, known as the U-Cycle approach, involves as a systematic methodology designed for assessing the reliability of complex systems (Dabla et al., 2017). The U-Cycle approach entails a multi-faceted analysis of the system, exploring different perspectives, including physical, structural, and temporal and logical considerations. Its main objective is to provide a thorough understanding of the system's behaviour and possible failure modes, thus contributing to a comprehensive understanding of the reliability of complex system. The challenge of assessing the reliability of a system consists is then to combine the structural, temporal, physical, and logical views into a single model.

As we delve into the intricacies of conceptual and holistic modelling for complex systems, incorporating the U-Cycle approach as a systematic methodology for reliability assessment, this thesis aims to contribute to the evolving field of reliability analysis. Through the synthesis of multiscale and multiview approaches, coupled with the systematic insights provided by the U-Cycle approach, we aim to provide a robust and comprehensive methodology for assessing and improving the reliability of complex systems in diverse real-world applications.

## 1.2 Overview of the 'U-cycle approach' and its Relevance to Dysfunctional Modelling

The "U-cycle approach" in the context of reliability modelling for multiscale-multiview complex systems provides a comprehensive framework that aim to address dysfunctional modelling and to facilitate the transfer of stress and its characterization across different system to component levels. This approach integrates different methodologies to systematically analyse the structural, temporal, physical, and logical aspects of complex systems, thereby enabling a holistic understanding and modelling of system reliability.

The U-cycle approach shown in the figure.2 illustrates a framework for assessing system reliability through both functional and dysfunctional views at the system and component levels. This structured methodology is particularly relevant for the reliability modelling of complex systems with multiple views.

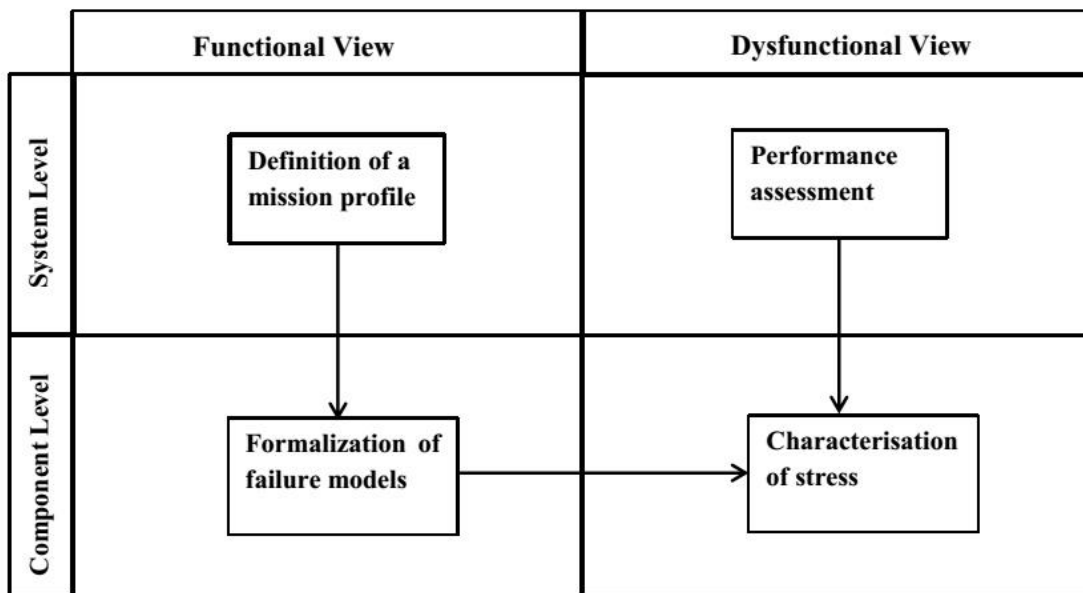

Figure 2. Proposed U-cycle approach.

In the functional view, the process begins at the system level with the "definition of a mission profile," which outlines the operational parameters and expected performance standards of the system. This mission profile is essential as it sets the baseline for system functionality against which actual performance can be measured. It encapsulates the design intent, the operational envelope, and the intended interactions between subsystems and components (Dabla *et al.*, 2017). Moving to the component level, "Formalization of models" translates the mission profile into specific, quantifiable parameters that individual components must meet. This involves the development of mathematical or simulation models that predict the behaviour of components under different operational scenarios. These models are critical for understanding not only when and how components might fail but also for providing insight into the resilience of the system's architecture and the redundancy built into the system (Dabla *et al.*, 2017)

The dysfunctional view complements this by focusing on "performance assessment" at the system level. This involves evaluating the actual performance of the system against the mission profile. It examines how the system behaves under stress, identifies performance gaps, and assesses the system's ability to perform its intended functions in the face of component degradation or failure. At the component level, "stress characterisation" involves identifying and quantifying the stresses experienced by each component during operation (Dabla *et al.*, 2017). This characterisation is a critical step as it links the physical phenomena experienced by the components to the failure models developed in the functional view. Understanding these stresses enables more accurate prediction of component lifetime and reliability and informs the maintenance and risk management strategies. The relevance of the dysfunctional view lies in its ability to identify, analyse, and mitigate the potential risks and failures within a system. By providing a framework for assessing system performance and characterising component stress, it enables the identification of weaknesses within the system. This,



## Introduction

in turn, informs the design process, leading to the refinement of the mission profile, the improvement of component design, and the development of better failure models (Dabla *et al.*, 2017). In essence, the U-cycle approach facilitates a holistic and iterative process of system and component evaluation, where the functional and dysfunctional views inform and enhance each other. By capturing both the design intent and operational reality, this approach provides a robust methodology for the reliability modelling of complex systems, ensuring that they can meet the requirements of their operational environment and mission objectives.

At its core, the U-cycle approach involves a structural view that decomposes the system into its constituent elements, facilitating the understanding of its architecture and the interdependencies between components, subsystems, and the overall system. This decomposition is critical for identifying potential points of failure and assessing the impact of the reliability of individual components on the system as a whole.

From a temporal perspective, the U-cycle approach considers the dynamic evolution of the system over time, taking into account the different operating phases of operation and their associated stresses. This view allows the modelling of how system and component reliability evolves in response to operational demands, thereby enabling for the prediction of system behaviour under various conditions.

From a Physical perspective, the approach examines into the mechanisms leading to component degradation, translates the stresses experienced by components into quantifiable impacts on reliability performance. This involves characterising the state variables that describe the system's response to operational stresses and identifying the degradation processes that can lead the system to dysfunction.

Logically, the U-cycle approach analyses the influence of component reliability on the overall system performance, incorporating material and functional redundancies to improve system resilience. This view facilitates the upward aggregation of reliability information, from component to subsystem to system level, enabling a comprehensive assessment of system reliability. By integrating Bayesian networks and dynamic modelling techniques, the U-cycle approach provides a powerful tool for the holistic modelling of complex systems. It addresses the challenges of multiscale-multiview complexity by providing a structured methodology for the assessing system reliability, taking into account the intricate interplay between structural, temporal, physical, and logical views.

### 1.3 Aim and Scope of the Thesis

To address the critical need for a comprehensive framework in reliability modelling of multiscale-multiview complex system, recent advances propose innovative methods that bridge the significant gaps inherent in traditional reliability assessment methods. Through the dynamic reliability modelling under complex loading conditions as introduced by Zhang *et al.*, we gain insights into the resilience of systems against continuous and shock loading (Zhang *et al.*, 2018). At the same time, Twum and Aspinwall's optimization methodology for systems with dual failure modes highlights the need for multi-criteria approach to reliability, underscoring the complexity of maintaining high initial system reliability (Twum and Aspinwall, 2018). Further enriching the field, the integration of intelligent machine learning models into operational reliability analysis demonstrates the potential for significant improvements in accuracy and efficiency in analyzing civil aircraft systems (Jia-Qi *et al.*, 2023). In addition, the adoption of event chain-based reliability modelling for space phased mission systems, and the innovative use of Bayesian networks to account for the fuzzy dynamics of faults, highlight the shift towards more adaptive and nuanced reliability models (Zuo *et al.*, 2021; Liu *et al.*, 2022). In addition, the framework for dependence modelling dependencies using copula functions in predicting system reliability highlights the importance of accurately modelling dependencies between system components, reinforcing the multifaceted approach required for contemporary reliability assessment of complex system (Pan, Fang and Wang, 2021). Taken together, these methodologies not only address the current limitations of traditional reliability assessment but also provide a solid foundation for the development of robust, reliable, and adaptable complex systems.

The methodologies underlying the conceptual framework for multiscale-multiview reliability modelling complex system, its turn out to be crucial to delve into the specifics and implications of the innovative approaches highlighted in recent research. Collectively, these methodologies collectively represent a significant leap forward in addressing the multifaceted challenges of reliability modelling in complex systems.

**Dynamic reliability modelling under complex load conditions:** This approach introduces a model that is sensitive to both continuous operational loads and sudden shock loads, a scenario common to many engineering systems but inadequately addressed by traditional static reliability models. By incorporating time-varying stressors and their effects on system components, this model provides a more realistic representation of system reliability over time, enabling better prediction and management of system failures (Zhang *et al.*, 2018).

**Multi-criteria optimization methodology for dual failure mode systems:** This methodology recognises the complexity of optimising systems that have more than one failure mode, each with potentially different implications for system reliability. Adopting a multicriteria approach, it allows for a balanced consideration of various performance metrics, such as reliability, cost, and operational efficiency, facilitating a more holistic optimization of complex systems (Twum and Aspinwall, 2018)



Operational reliability analysis using intelligent machine learning models: The integration of machine learning models, such as the intelligent extremum model, into operational reliability analysis represents a significant advancement in predictive capabilities. These models can analyse large data sets to identify patterns and predict failures more accurately than traditional statistical methods. This approach is particularly beneficial in complex systems such as civil aircraft, where operational data can be used to improve safety and reliability outcomes (Jia-Qi *et al.*, 2023)

Event Chain-Based Reliability Modelling for Space Phased-Mission Systems: Addressing the unique challenges of space missions, which often involve multiple, sequential mission phases with different reliability requirements, this methodology uses an event chain-based approach. It allows for the modelling of reliability across different mission phases, taking into account dependencies and transitions between them. This approach is critical for space missions such as Tianwen-1 Mars Probe, where the success of each phase depend on the previous ones, and any failure can jeopardise the entire mission (Liu *et al.*, 2022).

Bayesian Networks for Modelling Fuzzy Dynamics of Faults: Traditional reliability models often struggle with the inherent uncertainties and variabilities in complex systems. The use of Bayesian networks to model these fuzzy dynamics introduces a flexible and powerful tool for capturing the probabilistic relationships between different system components and their failure modes. This approach is particularly useful in multi-state systems where the state of components can vary over time and impact the overall system reliability in non-linear manner (Zuo *et al.*, 2021).

Dependence Modelling Using Copula Functions : Recognising the interdependencies between system components is critical for accurate reliability prediction in complex systems. Copula functions allow the construction of a multivariate distribution that captures these dependencies, providing a sophisticated framework for reliability prediction that goes beyond the limitations of traditional independent failure models. This methodology is essential for systems where the failure of one component can significantly affect the failure probabilities of others, necessitating a more interconnected approach to reliability modelling (Pan, Fang and Wang, 2021).

U-cycle approach: The Integration of the U-cycle approach with Bayesian networks involves creation of a systematic methodology that improves reliability assessment across different scales and perspectives of complex systems. This integration aims to exploit the predictive power of Bayesian networks and the iterative, reflective learning cycle of the U-cycle approach. The aim is to develop a more dynamic, adaptive model that can anticipate system failures and reliability issues by taking into account the intricate interactions and dependencies within complex systems. This methodological innovation aims to provide a holistic, nuanced understanding of system reliability, enabling more effective decision making and system design optimisation.

This thesis seeks to advance the field of system reliability modelling through the development and application of a novel multiscale-multiview approach. Central to this investigation is the integration of the U-cycle approach alongside Bayesian networks, a methodology designed to improve the accuracy and depth of reliability assessments within complex systems. By focusing on this

integration, the research aims to provide a robust framework capable of capturing the intricacies and dynamics inherent in complex systems across different engineering domains. These systems are characterised by their multifaceted behaviours arising, which arise from their multi-scale and multi-view nature, which present unique challenges to traditional reliability modelling techniques.

Methodologically, the scope of this thesis is limited to conducting a comparative analysis between the proposed Multiscale-Multiview framework and established reliability modelling methods. This comparison is crucial in assessing the relative effectiveness, adaptability, and applicability of the proposed framework in accurately modelling system reliability. Through this analysis, the research seeks to highlight the benefits and potential limitations of integrating the U-cycle approach with Bayesian networks, particularly in the context of complex systems that defy simple characterisation.

Geographically and temporally, the research does not impose any specific limitations, underlining the universal applicability of the proposed framework. This broad applicability suggests that the findings and methodologies developed in this research could be relevant and beneficial across a wide range of contexts and time periods. Such an approach not only enhances the generalisability of the research findings but also contributes to the ongoing discourse on improving reliability modelling practices in the face of evolving system complexities. In acknowledging the existing challenges within the field of reliability modelling, this thesis positions itself within a critical research niche. It aims to address these challenges through a novel, integrative approach that synergises the strengths of the U-cycle methodology and Bayesian networks. In doing so, the research aims to provide meaningful insights and tools that can assist in the development of more reliable, resilient, and efficient engineering systems, thereby advancing the state of the art in reliability modelling.

### **1.4 Research questions and hypotheses**

The full characterisation of the U-cycle raises non-trivial research questions related to the positioning and significance of the different views. As the diversity and complexity of systems continue to evolve, most of these questions remain open, and some are subject of research instantiated to the systems under study. The limitations of traditional reliability modelling techniques stem from their inability to fully account for the multidimensional nature of complex systems. These models often overlook the interconnections and interdependencies that are critical to understanding system behaviour. A conceptual and holistic approach to reliability modelling is proposed to bridge this gap, incorporating multiscale (from macro to micro levels) and multiview (including physical, logical, and operational perspectives) considerations. This approach aims to provide a more accurate representation of system reliability, taking into account for the myriad of factors that influence system performance. Therefore, the following research challenges have been specifically investigated and addressed:

### ***RQ1: How does stress propagate in complex systems, and what factors influence its transmission?***

Understanding stress propagation in complex systems is critical to for developing reliable models that can predict and mitigate potential failures. Stress propagation refers to the process by which stresses, or loads, applied to a system are transmitted through its components. This phenomenon is inherently multidimensional, involving physical, operational, and environmental factors that interact in complex ways. To effectively model and manage complex systems, it is essential to understand the mechanisms of stress propagation and its impact on system reliability.

#### Stress Propagation Mechanisms

It is important to understand the mechanisms stress propagation as it can be influenced by various factors, including the design of system, the materials used in its components, and the operating environment. In complex systems, stress is not uniformly distributed; it can be concentrated in certain components or pathways due to the system's configuration or external influences. This uneven distribution can lead to localised failures, which, if not addressed, can cascade and affect the overall reliability of the system.

#### Factors influencing stress propagation

1. **System design and configuration:** The layout and connectivity of components within a system have a significant effect on the transmission of stress. Systems designed with redundancy can better distribute stress and prevent failure propagation.
2. **Material properties:** The physical properties of materials, such as strength, flexibility, and fatigue resistance, play a critical role in their ability to withstand and propagate stress.
3. **Operational environment:** External conditions, such as temperature variations, mechanical vibration, and corrosive environments, can exacerbate stress propagation and lead to premature failures.
4. **Component interdependencies:** In complex systems, components often depend on each other for functionality. A failure in one component can cause additional stress in others, potentially leading to a domino effect of failures.

Understanding and effectively managing stress propagation is critical to ensuring the reliability and durability of complex systems. By integrating multidisciplinary approaches to model stress dynamics and implementing strategic mitigation measures, engineers can design more resilient systems that can withstand the challenges of their operational environments.

### ***RQ 2: What is the impact of component failure on overall system reliability?***

The dysfunction of individual system components plays a significant role in the overall reliability of complex systems. This section examines the effects of component failure, focusing on the identification of critical components whose failure can disproportionate the impact on the system integrity. Through the analysis of failure modes and effects, this part of the discussion highlights the

need for robust modelling techniques that can predict and mitigate the impact of component dysfunction on system reliability.

### ***RQ 3: Operational reliability issues***

Ensuring operational reliability in complex systems is fraught with challenges, from environmental stresses to maintenance practices. This section assesses current approaches to operational reliability, identifies areas where they fall short and propose improvements. A holistic approach to reliability modelling can incorporate operational factors, to provide a more comprehensive assessment of system performance under different conditions.

### ***RQ 4: A Multidimensional approach to reliability modelling***

A multidimensional approach to reliability modelling integrates different types of data and analytical methods to provide a more nuanced understanding of complex systems. This section outlines a conceptual model that embodies this holistic perspective, and discuss how it can improve the prediction, management, and mitigation of reliability problems. The proposed framework aims to address the dynamic and interconnected nature of complex systems, providing insights into how to improve system robustness and resilience.

### ***RQ5: Addressing current research gaps***

This thesis addresses the gaps in current reliability modelling practices by proposing a novel, multi-dimensional approach that considers for the complex interplay of factors that affect system reliability. This section highlights the specific contributions of the proposed research to the field, emphasising its potential to advance our understanding of complex system behaviour and improve reliability modelling techniques. These research questions are framed as key scientific challenges to emphasize the specific barriers that this work aims to overcome.

## **Hypotheses**

### ***Hypothesis 1: Multiscale-Multiview integration improves reliability prediction accuracy***

The integration of multiscale and multiview approaches in modelling of complex system reliability significantly improves the accuracy of reliability predictions compared to traditional single-scale models. The hypothesis is that capturing interactions across different scales and perspectives provides a more comprehensive understanding of system behaviours, leading to improved predictive capabilities.

### ***Hypothesis 2: Stress propagation influences system reliability***

The propagation of stress from the system level to the component level exhibits scale-dependent characteristics, that significantly influence the overall reliability of complex systems. This hypothesis states that understanding the nuances of how stress affects different scales is essential for accurate reliability modelling.

### ***Hypothesis 3: Component dysfunction leads to non-linear system response***

The dysfunction or failure of individual components leads to non-linear responses of the system, with the failure of having disproportionately large effects on subsystems or the whole system. This hypothesis examines the criticality of components and how their failure modes can trigger broader system vulnerabilities.

### ***Hypothesis 4: Predictive maintenance schemes improve operational reliability***

The implementation of predictive maintenance schemes based on multiscale-multiview reliability models significantly improves the operational reliability of complex systems. This hypothesis assumes that advanced modelling techniques can identify potential failure points before they occur, enabling timely maintenance actions that prevent system downtime.

### ***Hypothesis 5: Multiscale modelling approach unveils unique stress propagation dynamics***

The multiscale modelling approach, which integrates analyses across different scales from the microscopic to the macroscopic, reveals unique stress propagation dynamics cannot be observed at a single scale. This hypothesis explores how multiscale interactions affect the overall reliability of complex systems, providing insights into stress effects that are obscured when considered in isolation.

### ***Hypothesis 6: The U-Cycle approach and the superimposition of different views reveal interdependencies***

The U- cycle approach to reliability modelling, complemented by the superimposition of different views (structural, physical, temporal, logical), effectively reveals interdependencies and interactions within complex systems. This hypothesis suggests that such an approach provides a comprehensive understanding of system behaviours, enabling the identification of critical vulnerabilities and resilience factors.

### ***Hypothesis 7: Bayesian network modelling enhances predictive accuracy for system or component Failures***

Bayesian network modelling improves the prediction accuracy of component failures and their impact on complex systems by efficiently incorporating prior knowledge and updating beliefs in the light of new evidence. This hypothesis examines the effectiveness of Bayesian networks in managing uncertainties and predicting failure probabilities, taking into account the complex interrelationship and dependencies within the system.

This manuscript is structured as follows: Chapter 2 explores the structural view of reliability modeling, followed by the temporal, physical, and logical perspectives in subsequent chapters. Chapter 6 integrates these views into the U-Cycle approach, and the final chapter presents the conclusions and future research directions.

## Introduction

## Introduction

# Chapter II

## Structural view

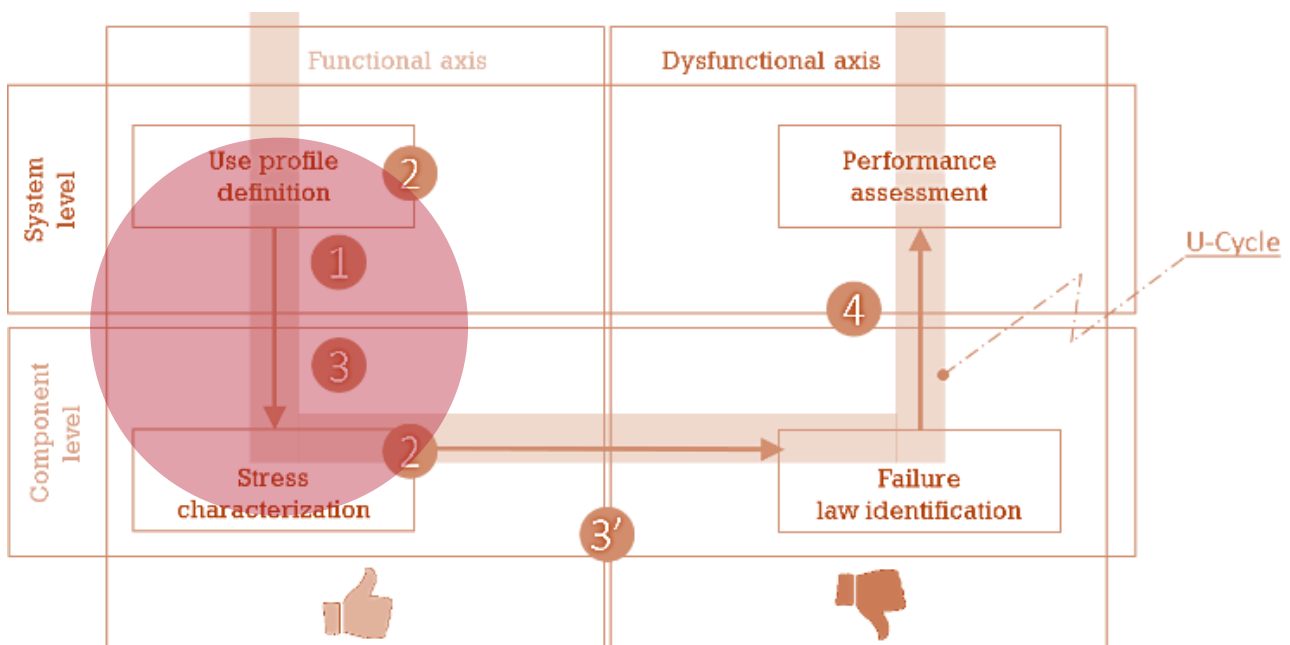



## 2.1 Introduction to Structural View

In the evolving landscape of systems engineering, the structural view has emerged as a cornerstone for understanding and improving the reliability of complex systems. This view, which is fundamental to the multiscale-multiview modelling of system reliability, transcends traditional analytical methods by integrating different perspectives on the system architecture and its functional and dysfunctional behaviours (*An Introduction to Model-Based Systems Engineering (MBSE)*, 2020). Its importance is particularly pronounced in the field of transport systems, where the multifaceted interplay of electronic components and their operating environments requires a holistic assessment. In systems engineering, the structural view embodies a comprehensive modelling framework that describes the organisation of a system alongside the architecture of the data it processes. It intricately maps the interrelationship between system components, encompassing both their functional roles and their physical manifestations (*System Architecture - SEBoK*, 2024). This analytical lens is central to the precise articulation of a system's architecture, ensuring its alignment with pre-defined requirements and overarching goals. Extending this concept, the structural view can be seen as a universal scaffolding that informs the design and deployment of complex systems across multiple domains. It not only helps to achieve operational coherence and efficiency but also serves as a critical cornerstone in the design and implementation of systems that are robust, scalable, and fully aligned with strategic intents. This expanded understanding underscores the importance of structural views in the holistic development and management of complex systems and emphasises its role in fostering innovation and excellence in systems engineering.

The structural view is based on a systemic amalgamation of different views characterising the architecture of the system and its operational dynamics. This approach, which differs significantly from conventional methods, enables a comprehensive assessment of system reliability. By considering the system in its entirety - taking into account structural, temporal, physical, and logical dimensions- the structural view facilitates a more nuanced and accurate modelling of complex system behaviour. Its relevance is underscored by the pressing need for reliable transportation systems, where the increasing integration of sensitive electronic components and escalating customer expectations for robustness necessitate methodological rigor in reliability assessment. Recent studies highlight the importance of this approach in addressing the complexity and reliability of modern systems, particularly in the transportation sector (Gao & Xu, 2021; Hoekstra et al., 2019; Kuś et al., 2024).

Multiscale modelling is a powerful approach in engineering that allows for the analysis and prediction of the behaviour of complex systems by bridging different lengths and time scales. The key idea is to divide a complex engineering system into subsystems or components at different hierarchical levels and then develop models that can accurately capture the interactions and dynamics across these scales. The structural view of a complex engineering system is a crucial aspect of multiscale modelling. It involves the decomposition of the system into various subsystems or components, such as individual parts, assemblies, and the overall system. This hierarchical representation enables the use of appropriate modelling techniques at each scale, from the atomic or molecular level to the macroscopic system level. Recent advancements have demonstrated the effectiveness of this approach in improving the accuracy and efficiency of modelling complex systems, facilitating better design and analysis (Chen, Wang & Korsunsky, 2022; Kuś, Mucha & Jiregna, 2024; Xia & Ruiz Pestana, 2023).

At the microscopic scale, models based on quantum mechanics, molecular dynamics, or other atomistic simulations can be used to understand the fundamental physical and chemical processes that govern the behaviour of materials and structures. These models provide insights into the properties and performance of individual components or materials. Recent studies have highlighted the importance of these microscopic models in accurately capturing material behaviour (Xia & Ruiz Pestana, 2023). As the scale increases, mesoscopic models, such as those based on the finite element method or other continuum-based approaches, can be used to capture the collective behaviour of the subsystems and their interactions. These models bridge the gap between the microscopic and macroscopic scales, allowing for the prediction of the overall system's performance. Advances in multiscale modeling techniques have demonstrated the effectiveness of mesoscopic models in enhancing our understanding of subsystem interactions and overall system behaviour (Chen, Wang & Korsunsky, 2022; Kuś, Mucha & Jiregna, 2024).

Finally, at the macroscopic scale, the entire engineering system can be modelled using techniques such as finite element analysis, computational fluid dynamics, or other system-level simulations (Hoekstra *et al.*, 2019; *Multiscale Modelling - an overview | ScienceDirect Topics*, 2024). These models integrate the information from the lower scales to provide a comprehensive understanding behaviour of the system under different operating conditions. The key challenge in multiscale modelling is to establish robust and efficient methods for seamlessly coupling the models across different scales, ensuring that the information and knowledge gained at one scale is properly transferred and incorporated into the models at other scales (Schön, Doll and Jansen, 2010). This requires the development of advanced mathematical and computational techniques, as well as close collaboration between experts in different disciplines, such as materials science, mechanics, and computational science. By adopting a multi-scale modelling approach, engineers can gain a deeper understanding of the complex interactions and phenomena within a system, leading to more accurate predictions, improved design, and ultimately, the development of more efficient and reliable engineering systems. (Hoekstra *et al.*, 2019; *Multiscale Modelling - an overview | ScienceDirect Topics*, 2024)

Despite its potential, the literature reveals a dearth of frameworks that holistically address the application of structural views to multiscale modelling, particularly in the realm of system reliability. This gap is particularly striking in the area of transportation systems, where the advent of sophisticated electronic systems and the imperative for operational reliability underscore the need for innovative modelling approaches. This work attempts to fill this gap by proposing a novel framework for the application of a structural view to multiscale reliability modelling, thereby contributing to the theoretical and methodological advancement of the field. This review aims to meticulously map the theoretical underpinnings and methodological advances relevant to the structural view, with a particular focus on its application to the reliability modelling of complex systems. By synthesising existing literature, the review seeks to describe the current state of knowledge, identify gaps, and articulate the potential of the structural view to improve our understanding and assessment of system reliability.

To strengthen the connection between the proposed modelling approach and systems engineering, this work expands beyond theoretical explanations by integrating practical implementation strategies. By aligning the structural view with Model-Based Systems Engineering (MBSE) principles, the proposed methodology ensures a systematic, lifecycle-oriented approach to reliability assessment. To enhance clarity and applicability, a detailed case study is provided, illustrating how the methodology can be operationalized in a real-world aerospace system. This example demonstrates step-by-step reliability modelling, including structural decomposition, stress propagation analysis, and iterative refinement using computational tools such as Bayesian Networks and Finite Element Analysis (FEA). By offering a concrete, applied illustration, this work transitions from conceptual foundations to practical, actionable insights, making the methodology accessible for industry adoption and further research development.

## 2.2 Relevant theoretical framework

### 2.2.1 Historical perspective

The history and evolution of diagnostic and prognostic systems in critical applications, particularly in the commercial and defence sectors, represents a complex process characterised by diverse approaches and methodologies. This history ranges from the early manual practices to the sophisticated, automated technologies that characterise the contemporary health management of systems today. Initially, health management in early-generation aircraft was predominantly manual, involving the physical detection and isolation of problems using basic tools such as schematics and voltmeters. As technology advanced, these practices began to evolve. The introduction of built-in test equipment (BIT), alarms, and trend analysis marked the first significant move towards automation, providing early warnings of safety-critical situations. However, despite these advances, there was still a reliance on manual troubleshooting methods by system maintainers. In the 1950s and 1960s the concept of providing fault indications available directly on line-replaceable units (LRUs) through mechanical and later, light-emitting diode (LED) indicators, emerged to improve the troubleshooting process. This era saw the introduction of built-in test equipment (BITE), which reduces reliance on extensive ground-support equipment to test critical components (Vachtsevanos, 2006).

The subsequent digital revolution in the 1970s transformed BITE into a digital affair, enabling the display of fault detection and isolation information via numeric codes on LRU panels. This digital leap facilitated a more accurate diagnosis of faults through detailed codes linked to specific issues, as seen in aircraft models like the Boeing 757/767 and Airbus A300/310. However, the proliferation of systems and the need for individual display mechanisms for each LRU presented new challenges. The advent of digital data buses and integrated systems called for a more unified approach to maintenance displays. The introduction of central fault display systems (CFDS) in the mid-1980s, exemplified by the ARINC 604 standard, represented a pivotal moment. It allowed for a consolidated view of maintenance data across various systems, streamlining the process and reducing costs associated with multiple LRU displays. This approach became a staple in later aircraft models, facilitating easier access to maintenance information (Vachtsevanos, 2006).

Despite these advancements, the increasing complexity and integration of systems introduced challenges in isolating faults effectively. The early 1990s saw the development of ARINC 624, defining a more integrated maintenance system capable of consolidating fault indications from multiple systems. This innovation reduced the need for ground-support equipment, enabling condition-based maintenance through the integrated maintenance system. As diagnostic and prognostic systems continue to evolve, the balance between enhancing fault isolation capabilities and managing the potential drawbacks of additional sensors—such as increased cost, weight, and complexity—remains a critical consideration. The journey from manual troubleshooting to sophisticated, automated health management systems illustrates a relentless pursuit of efficiency and reliability in maintaining critical systems, ensuring their safe and effective operation (Vachtsevanos, 2006).

In recent years, advancements in diagnostic and prognostic systems have continued to evolve, with significant improvements in data-driven predictive maintenance (PdM) systems. The implementation of on-board sensors and data-driven algorithms has enabled continuous monitoring and prediction of aircraft health, leading to more efficient maintenance processes (Mitici et al., 2023). These advancements pose new challenges, including ensuring the reliability of condition monitoring systems and building stakeholder trust in data-driven technologies (Verhagen et al., 2022).

Artificial intelligence (AI) and machine learning are increasingly playing crucial roles in predictive maintenance, helping to predict when parts might need repair or replacement. This reduces the risk of in-flight malfunctions, enhancing overall safety (Amprius Technologies, 2023). AI-driven systems also aid in optimizing air traffic flow, reducing congestion, and improving route efficiency, which further contributes to operational safety and cost savings (Amprius Technologies, 2023). Moreover, innovative technologies such as 3D printing and new composite materials are revolutionizing aircraft maintenance. 3D printing enables the creation of complex parts quickly and cost-effectively, while advanced composites offer superior strength and corrosion resistance compared to traditional materials like aluminium (North Central Institute, 2023). These advancements necessitate new technical training for aviation maintenance technicians to keep pace with the rapidly evolving technology landscape (Embry-Riddle Aeronautical University, 2023).

The journey from manual troubleshooting to sophisticated, automated health management systems underscore the relentless pursuit of efficiency and reliability in maintaining critical systems to ensure their safe and effective operation (Vachtsevanos, 2006; Williams, 2023; Aeologic, 2023). The balance between enhancing fault isolation capabilities and managing the potential drawbacks of additional sensors—such as increased cost, weight, and complexity—remains a critical consideration.

### 2.2.2 Comprehensive review of existing literature

The structural view, in the context of systems engineering and design, refers to a progressive description of a system by breaking it down into its constituent sub-assemblies and components. This approach allows for a hierarchical representation of complex systems, making it easier to understand,

analyze, and manage their structure and functionality. A comprehensive review of existing literature on structural view reveals several key aspects:

### 1. Hierarchical decomposition

Hierarchical decomposition in structural view employs a top-down approach to system description, beginning with the overall system and progressively breaking it down into smaller sub-assemblies and components as shown in the figure 3 below. This method enhances understanding of the system's organization and relationships between its parts. Recent research, such as in prompt-based continual learning, demonstrates its effectiveness in managing complex tasks by creating more manageable sub-tasks, thus improving performance and reducing errors in task identification (*Hierarchical Decomposition of Prompt-Based Continual Learning*, 2024).

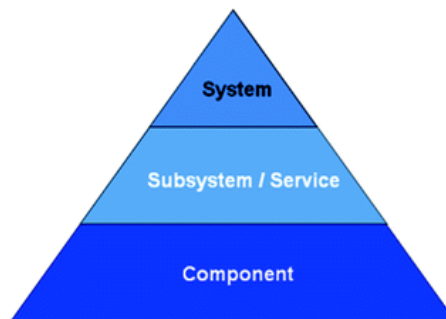

Figure 3. Structural breakdown

### 2. Application in product design:

The concept of Structural View is increasingly significant in product design and manufacturing, particularly with the advent of advanced additive manufacturing (AM) technologies. Structural View allows engineers and designers to break down complex products into interconnected sub-assemblies, which enhances modular design and streamlines assembly processes.

Recent studies highlight the effectiveness of this approach in various industries. For instance, Design for Additive Manufacturing (DfAM) frameworks have evolved to integrate modular design, which enables the creation of lightweight structures with optimized performance characteristics. This method facilitates the efficient assembly of intricate products by considering material properties, manufacturing constraints, and functional requirements during the design phase (Ribeiro, Bernardo and Andrade, 2021; Mandolini, Pradel and Cicconi, 2022; Egan, 2023).

Moreover, topology optimization is a critical aspect of structural design in AM. This technique involves computationally determining the optimal layout of materials within a given design space, thereby improving the structural efficiency and reducing material usage. Topology optimization is particularly beneficial in creating complex geometries that are both lightweight and robust, further contributing to modular and efficient product designs (Nellippallil *et al.*, 2020; Ribeiro, Bernardo and Andrade, 2021).

### 3. Progressive collapse analysis:

In structural engineering, the concept of structural view has been applied to progressive collapse analysis. This approach involves examining how the failure of one structural element can lead to the collapse of adjacent elements, potentially resulting in a disproportionate failure of the entire structure (Izzuddin *et al.*, 2007)

### 4. System engineering

In systems engineering, the structural view is essential for modelling complex systems, helping engineers understand and manage interactions between subsystems. This approach is especially valuable in aerospace, automotive, and software development. In aerospace, Model-Based Systems Engineering (MBSE) frameworks enable early design decision exploration, improving system reliability and integration (Uckun *et al.*, 2011). In the automotive industry, MBSE integrates electrical, mechanical, and software domains, optimizing overall system performance and preventing failures. In software development, MBSE enhances complexity management and ensures consistency throughout the development process (Madni and Sievers, 2018).

### 5. Modular design

Recent research highlights the significance of modular design in product development, which is greatly supported by the structural view approach. structural view enables designers to create independent, interchangeable modules that can be easily combined to form complex systems. This method allows for greater flexibility, scalability, and ease of assembly in product design, making it an effective strategy for developing complex products (Mandolini, Pradel and Cicconi, 2022; Egan, 2023). The modular design also enhances maintainability and upgradeability, as individual modules can be replaced or updated without affecting the entire system (Nellippallil *et al.*, 2020; Ribeiro, Bernardo and Andrade, 2021).

### 6. Digital-twin technology

The concept of structural view is integral to digital twin technology, where virtual representations of physical systems are created. Digital twins use hierarchical structures to represent components and sub-assemblies of the physical system, facilitating detailed modelling and analysis. This approach allows for real-time monitoring, simulation, and optimization of systems, improving efficiency and performance in various industries such as manufacturing, healthcare, and aerospace (Uckun *et al.*, 2011; Madni and Sievers, 2018). By mirroring the physical system digitally, engineers can predict issues, plan maintenance, and optimize operations, leading to significant cost savings and enhanced productivity.

### 7. Industry 4.0 and smart manufacturing:

The structural view approach is fundamental to the development of modular design strategies, which are essential for Industry 4.0. This approach enables designers to create independent, interchangeable



modules that can be easily combined and reconfigured to form complex systems. Such modularity allows for rapid adaptation to new production needs, supporting the vision of ultra-customization in manufacturing.

Beyond the physical aspects of manufacturing, the application of the structural view in Industry 4.0 also extends to data and knowledge management systems. This approach facilitates the effective capture, storage, and utilization of design and manufacturing knowledge. The hierarchical organization of information, mirroring the structure of products or systems, enhances overall efficiency and decision-making processes in smart manufacturing environments. This alignment ensures that both physical and informational aspects of manufacturing systems are optimized for flexibility and adaptability, crucial for the dynamic demands of modern production (Mandolini, Pradel and Cicconi, 2022; Egan, 2023).

### 2.2.3 Discussion of different modelling principles

The discussion of different modelling principles is essential for understanding and designing complex systems across various fields. These principles provide a framework for breaking down intricate systems, ensuring precision, and maintaining a connection to real-world applications. They advocate for the use of multiple models to capture different aspects of a system, emphasizing visual representation for clarity and modularity for flexibility. Additionally, recent advancements highlight the integration of structural modelling with advanced technologies and data-driven approaches, enhancing performance and adaptability in fields like smart manufacturing and software engineering. This comprehensive approach facilitates better design, optimization, and understanding of complex systems.

#### **1. Hierarchical decomposition modelling or principle**

Hierarchical decomposition modelling is a vital modelling technique and principle used in system design and analysis to manage complex systems by breaking them down into smaller, manageable parts. As a principle, it simplifies complex systems by focusing on different levels of abstraction, promoting modular thinking where each component can be considered independently, ensuring scalability, and clarifying relationships between different parts of the system (Ariyo et al., 2008).

In practice, this technique employs a top-down approach, starting with the overall system and progressively dividing it into smaller components. It involves creating multiple levels of abstraction, often visualised through tree structures or nested diagrams, to illustrate hierarchical relationships. This method is widely applied across various fields, including systems engineering, software architecture, artificial intelligence, organisational management, cognitive science, and environmental modelling. Despite its effectiveness, Hierarchical Decomposition faces challenges such as managing emergent properties that arise from interactions between subsystems and defining appropriate boundaries between these subsystems. Nonetheless, it remains a cornerstone of modern system analysis and design, continuously evolving with advancements in technology

and data-driven approaches to enhance its applicability and efficiency in handling complex systems (Blanco and Lo, 2023; Kumar *et al.*, 2023; Vakili and Salehi, 2023).

### 2. Numerical modelling

Numerical modelling is a key technique and principle in flood analysis and prediction. It involves using mathematical algorithms and computational methods to solve complex equations governing flood dynamics. The process includes discretising the physical domain into grid cells, solving equations at these points, and advancing the solution in time to simulate flood evolution. Handling boundary conditions appropriately ensures accurate simulations.

As a principle, numerical modelling relies on mathematical approximations and computational techniques to represent and solve complex physical processes. This approach allows for detailed visualization and analysis of flood dynamics, aiding in understanding and prediction. Recent advancements have enhanced the accuracy and applicability of numerical models. High-resolution modelling now allows for detailed visualization of flood characteristics, and modern models can handle complex topographies and urban environments effectively. Advanced computational methods, such as those offered by the 'MIKE URBAN' software, provide various flow approximation techniques, improving the precision of flood predictions (Blanco and Lo, 2023; Kumar *et al.*, 2023; Vakili and Salehi, 2023)

Despite its power, numerical modelling faces challenges, including high data requirements and the need for reliable measurements for model calibration, particularly in developing regions. Calibration and validation are crucial to ensure predictive capability, requiring robust data and rigorous testing.

### 3. Causal modelling

Recent advancements in Structural Equation Modelling (SEM) have introduced nonparametric SEM, also known as Pearl's structural causal model. This technique enhances traditional SEM by allowing for a more comprehensive understanding of causal relationships within complex systems. The image 4 illustrates different levels of causal modelling, from mechanisms described by differential equations to structural causal models, causal graphs, and Bayesian networks, each corresponding to a tier in the causal hierarchy: counterfactuals, interventions, and associations.



## Structural view

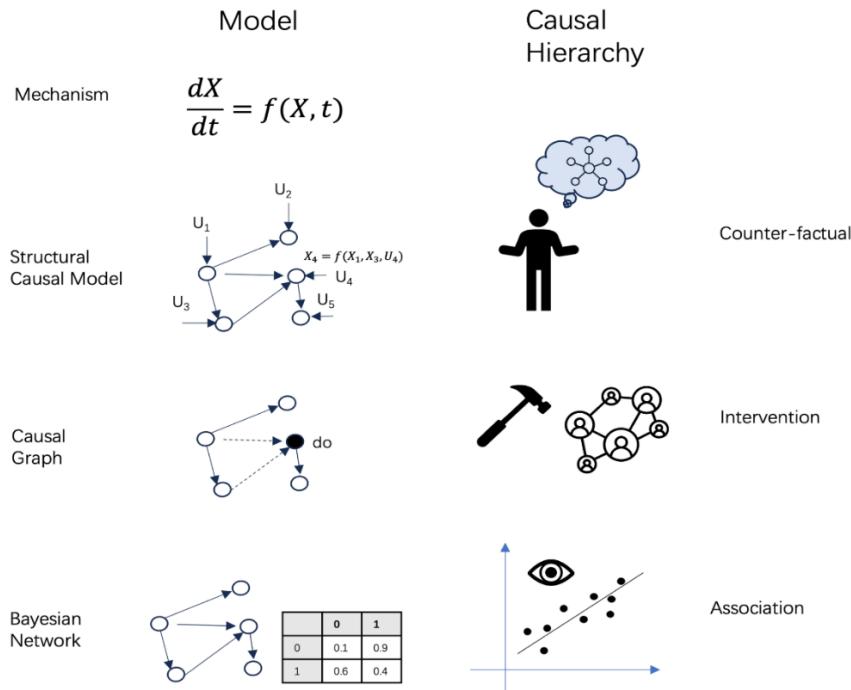

*Figure 4. An Example of causal modelling*

Nonparametric SEM, developed by Judea Pearl, extends the traditional linear SEM framework to include nonlinear relationships and heterogeneous effects. It encodes causal assumptions in a transparent language, translates these assumptions into counterfactual notation, and uses graphical models to represent the causal logic implied by the equations. Key features of nonparametric SEM include flexibility in modelling, allowing for linear, non-linear, or non-parametric relationships; clear causal interpretation of model parameters; and the use of directed acyclic graphs (DAGs) for graphical representation of causal relationships. This framework also enables the estimation of counterfactual probabilities and the evaluation of "what-if" scenarios, accommodating a wider range of variable types and relationships compared to traditional linear SEM (Pearl, 2012; Bollen and Pearl, 2013).

### 4. Multiscale- modelling

The Multi-Model Approach is a methodology for studying and representing complex systems, acknowledging the limitations of a single model to capture all facets of such systems. This approach promotes the use of multiple, interrelated models to gain a comprehensive understanding of the system under study (Fishwick *et al.*, 1994).

The fundamental principle of this approach is that different models can capture various aspects or perspectives of a complex system, each offering unique insights that might be missed by relying solely on one model. By integrating these diverse models, researchers and analysts can achieve a holistic view of the system's behaviour, structure, and dynamics (Elfelly *et al.*, 2014; Korolkova, Kulyabov and Hnatic, 2020).

Key advantages of the multi-model approach include:

- **Comprehensive representation:** It provides a complete representation of complex systems by addressing different aspects through various models.
- **Flexibility:** Researchers can select and combine models that best suit the specific system or problem at hand.
- **Multiple levels of analysis:** This approach allows for the exploration of systems at multiple levels, from microscopic details to macroscopic patterns.
- **Improved understanding of interactions:** Using multiple models enables a better examination of interactions between the system and its environment and relationships among different components within the system.
- **Addressing complexity:** It is particularly effective for studying complex systems where single-paradigm models fail to capture all relevant aspects.

The figure 5 illustrates the multiscale modelling approach, showing the integration of top-down and bottom-up methodologies across various length scales—from electronic and atomistic to microstructure and macroscale—highlighting the interplay between structure, properties, and performance in disciplines such as physics, chemistry, materials science, and engineering.

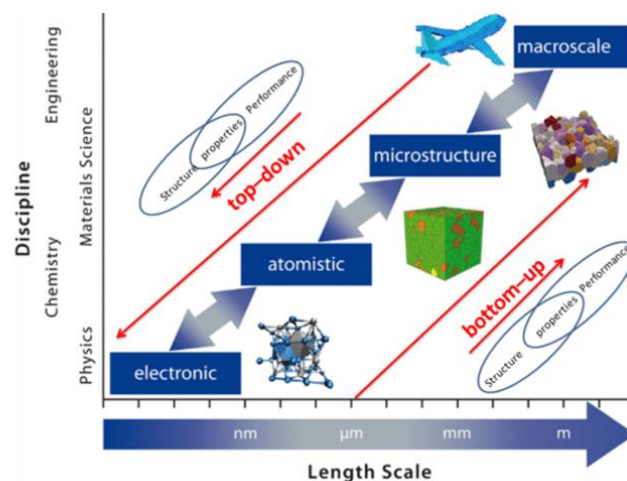

Figure 5. Multiscale modelling approach

In practice, the multi-model approach might involve combining various types of models, such as equation-based models, stochastic models, computational models, and network models. Each type of model provides unique insights into different aspects of the complex system, facilitating a more nuanced and comprehensive understanding. While the multi-model approach offers significant advantages, it also requires careful consideration in selecting and integrating appropriate models to ensure they complement each other and provide meaningful insights into the complex system being studied.

## 5. Composite modelling

Composite-based structural equation modelling (SEM), also known as partial least squares path modelling (PLS-PM) or variance-based SEM, is a valuable methodology for analysing complex systems and their structural relationships. This approach serves as an alternative to traditional factor-based SEM by using emergent variables to represent abstract concepts, allowing for the modelling of constructs without a clear underlying latent structure (Schuberth, Rademaker and Henseler, 2022).

In understanding complex systems, composite-based SEM excels in several areas. It integrates substantial theories with auxiliary theories, capturing both theoretical relationships and measurement aspects of the model. This is crucial for accurate modelling in various research contexts, such as exploratory and predictive research, where emergent constructs are the focus.

Composite-based SEM also allows for detailed analysis of mediation and indirect effects, which is essential for uncovering the intricate interactions within a system. Moreover, it provides robust methods for assessing overall model fit, ensuring the validity of the structural representation of complex systems. The flexibility of composite-based SEM extends to handling diverse types of data, including single-indicator constructs and categorical variables. This versatility makes it suitable for modelling a wide range of complex systems, offering researchers a comprehensive framework for understanding and analysing the nuanced relationships and emergent properties that characterize these systems (Florian, 2017).

### 2.2.4 Critical analysis of relevant articles

Understanding the structure of complex systems is critical in various engineering disciplines, particularly when developing and maintaining sophisticated products. This literature review synthesizes key methodologies and findings from several articles focused on the structural analysis and design of complex systems.

#### ***Multiple abstraction levels in modelling product structures***

One study addresses the challenge of managing product variety and maintaining systematic maintenance records in industrial settings. The authors introduce a methodology that supports the evolution of product models by organizing them into specialisation hierarchies, allowing for multiple abstraction levels. This approach aims to efficiently manage product customization demands and after-sales services. The methodology's strength lies in its ability to handle diverse product information through abstraction, making it particularly useful in scenarios with high product variability. However, empirical validation through case studies in various industries could further bolster its applicability and reliability (Männistö *et al.*, 2001).

### ***Architecture-centric design approach for multi-disciplinary product development***

Another research emphasizes an architecture-centric design approach to manage the complexities of multi-disciplinary product development. This involves establishing a common language and shared understanding among team members, which is crucial for integrating various disciplines in product development. The article highlights the importance of system architecture in managing complexity and promoting modularity. Nevertheless, the practical implementation of establishing a common language across disciplines may require more detailed guidelines and real-world examples to be fully operational (A. A. A. Cabrera *et al.*, 2014).

### ***A heuristic method for identifying modules for product architectures***

A third paper describes heuristic methods to identify modules from functional models, emphasizing modular design early in the product development process. The method uses a functional basis and time-ordered function chains to formalize the functional models. The method's application in consumer products demonstrates its potential in early-stage modular design. However, its reliance on heuristic rules may limit its generalizability across different product types, suggesting the need for adaptive frameworks tailored to specific industries (Stone, Wood and Crawford, 2000).

### ***A multi-skeleton modelling approach based on top-down design and modular product design***

The integration of Top-Down Design (TDD) and Modular Product Design (MPD) to handle the complexities of designing large-scale products is demonstrated in another approach. It employs different types of skeletons to represent spatial arrangements, interface features, and key design spaces. This multi-skeleton modelling approach addresses hierarchical decomposition and modularity robustly. However, its complexity might pose challenges in terms of implementation and integration into existing design processes without substantial training and adaptation (Chu *et al.*, 2016).

### ***A new methodology to analyse the functional and physical architecture of existing products***

The Datum Flow Chain (DFC) method, introduced in another paper, facilitates the mapping of components to their respective functions, aiding in the identification of modular subassemblies. This method provides a clear framework for understanding product architecture, enhancing the ability to design reconfigurable assembly systems. However, its effectiveness in highly dynamic environments or products with rapidly evolving technologies remains to be tested (Stief *et al.*, 2018).

### ***A three-level abstraction hierarchy to represent product structural information***

The PRONTO (Product Ontology) model uses a three-level abstraction hierarchy to manage product variants, including Family, Variant Set, and Product levels. This structured approach to product information management is particularly useful in industries with extensive product variants. Future research could explore its integration with advanced data analytics tools to enhance its utility in predictive maintenance and lifecycle management (Vegetti, Leone and Henning, 2010).

### ***Characterising complex product architectures***

Finally, methods such as Dependency Structure Matrix (DSM), Molecular Diagrams, and Visibility-Dependency (VD) signature diagrams are proposed to describe and analyse complex product architectures. These methods help in understanding modularity and managing dependencies. While

these tools offer valuable insights for visualizing and managing product architecture, their application might require significant computational resources and expertise, which could be a barrier for some organizations (Sharman and Yassine, 2004). The reviewed articles collectively emphasize the importance of structured methodologies in managing the complexities of product design and development to understand the structure of the system. They offer various approaches to abstraction, modularity, and system architecture, each with its strengths and potential limitations.

### 2.3 Methodology for structural view analysis

In the intricate landscape of systems theory, the dynamic interplay between causality and consequences within hierarchical structures provides a fertile ground for re-evaluating traditional paradigms of diagnosis and prognosis. The conventional approach posits a dichotomy in which causal processes trace an upward path through the nomenclature of system, embodying a bottom-up logic, while the exploration of consequences, or prognosis, adopts a top-down perspective. However, this binary scheme oversimplifies the nuanced relationships that exist within complex systems, particularly when analysing the interactions between Basic Components (BC) and the Sub-Systems (SS) to which they belong. This chapter aims to unravel the intricate web of interactions that underpin the functioning and dysfunctioning of systems using a dual lens that challenges the traditional causal-consequential hierarchy.

#### **Structural View (Spot 1):**

This part focuses on progressively describing the system by breaking it down into its component parts. Put simply it's about understanding the structure of the system and how its parts fit together. Understanding the structural view of a product and establishing its hierarchical nomenclature at a descriptive level is relatively straightforward. However, selecting different levels within the system and arranging of these components are a more complex and non-trivial task (Hsieh, 2014). To ensure the overall reliability of the whole system, the effort is allocated to the different components. This allocation is guided by historical data or assumptions about the failure rates or expected lifetimes of these individual components. The characterisation of the structural view and therefore of the hierarchical nomenclature of a product is quite immediate at a purely descriptive level. On the other hand, the choice of the different levels and the layout of the system are not trivial. The research topics in this respect essentially concern reliability allocation issues (Marouani and Al-mutiri, 2021), which determines the initial organisation of the system architecture to achieve the robustness objectives that has been assigned to it. Thus in, order to achieve reliability for the whole system, the effort is distributed among the different components of the system based on past knowledge or the assumptions of their failure rates or life expectancy. This initial architecture can be questioned if the output of the logical view (Spot 4) shows that the specified reliability values cannot be achieved as shown in the Figure 6 below. The proposed approach falls within the framework of a looped design and justify the U-Cycle qualification.

## Structural view

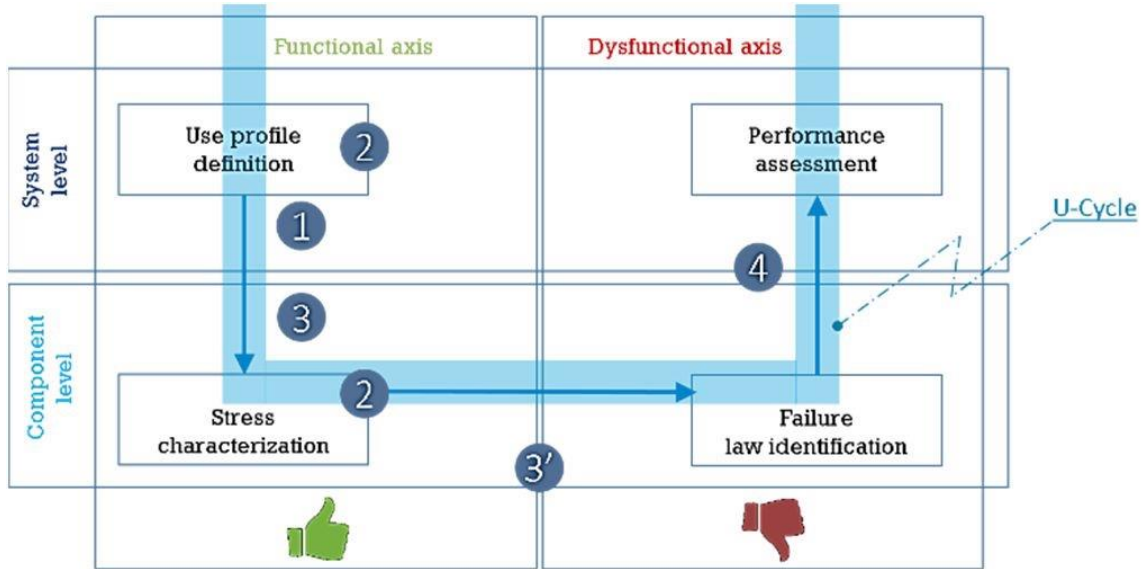

Figure 6. U-Cycle Approach

Central to our exploration is the assertion that the relationship between BCs and SSs is not simply linear or unidirectional but rather a bidirectional continuum in which cause, and effect are interdependent and reciprocal. By critically examining the operational dynamics from both top-down and bottom-up perspectives, we uncover a more holistic understanding of systemic functioning. To navigate within complexity, it is imperative to clearly define the notions of functional and dysfunctional states, thereby introducing a lexicon tailored to encapsulate the myriad interactions within the systems. Through this analytical framework, we propose to dissect the mechanisms by which SSs influence their constituent BCs and, conversely, how BCs influence the overarching SSs. This structural view is not merely academic but serves as a practical framework for diagnosis and prognosis within complex systems, whether be they mechanical, biological, or sociotechnical in nature. By refining our understanding of these interactions through a specific language that distinguishes between conditions and effects (in the realm of functioning) and causes and consequences (in the context of dysfunction), we can improve our ability to predict, manage, and remediate systemic problems. In this thesis, therefore, not only challenges conventional wisdom but also lays the groundwork for a more nuanced and effective approach to systems analysis and management.

		Basic Component (BC)						Sub-System (SS)			
		Functional (F)		Dysfunctional (D)				Functional (F)		Dysfunctional (D)	
		Conditions	Effects	Causes	Consequences	Conditions	Effects	Causes	Consequences		
Sub-system (SS)	F	R				S					
	D			R				S			
Basic Component (BC)	F		S				R				
	D								R		

**Table 1 Basic Component (BC), Sub-System (SS), Functional and Dysfunctional relationships**



The integrity of a system is dependent on the seamless interaction and interdependency between its basic components (BC) and subsystems (SS).

- At SS level (downwards)
  - The SS operation request results in the component being called upon
  - Operation of the SS is conditional on an appropriate response from its components
  - SS malfunction is caused by the inappropriate response of its components
  - The malfunction of the SS results in its components not being solicited.
  
- At BC level (in the upward direction)
  - Operation of the BC causes the SS to be solicited
  - BC operation results in SS response
  - The absence of a request to operate the BC causes the SS not to be solicited
  - The malfunctioning of the BC results in an inappropriate response from the SS

Table 1 illustrates the interdependencies and interactions between the functional and dysfunctional states of basic components (BC) and subsystems (SS) in a system. The table categorises the conditions, effects, causes, and consequences of these states, highlighting how the integrity of the entire system relies on these relationships.

In hardware systems such as computer architecture, system integrity is measured by robustness, fault tolerance, and performance under different operational conditions. For example, the seamless interaction between BCs and SSs ensures the system can withstand faults and perform reliably (Peculis and Shirvani, 2017). System integrity is crucial throughout the system development life cycle and systems engineering processes. Complex systems must meet requirements such as affordability, reliability, adaptability, security, and resilience. Different systems have various factors that contribute to their overall integrity (Wang et al., 2020; Peculis and Shirvani, 2017).

For infrastructure systems, system integrity is defined as the "state of a system in which it performs its intended functions safely without being degraded by changes or disturbances in its internal or external environment." Key factors contributing to the integrity of infrastructure systems include operational performance, safety, and resilience (Peculis and Shirvani, 2017). Interdependency between components and subsystems is critical to system integrity. As shown in Table 1, failures or disruptions in one part of an interdependent system can cascade through the entire system, leading to catastrophic consequences. Analysing the joint influence of interdependencies and local network structures is essential for understanding and improving the structural vulnerability of complex, partially interdependent systems (Foresight review of structural integrity and systems performance, 2015; Wang et al., 2020).

Several approaches can be used to model hardware systems with a multi-level physical architecture, various approaches can be employed, including top-down, bottom-up, and middle-out methods.

## Structural view

These strategies offer different perspectives on how to design and represent complex hardware structures:

**Top-down approach:** This method starts with an overarching view of the system and then progressively breaks it down into smaller components. It starts by defining the high-level functionalities of the system and then decomposing them into more detailed subsystems and components. This approach provides for a clear understanding of the overall architecture of the system before delving into specific details.

**Bottom-up approach:** In contrast to the top-down approach, the bottom-up strategy starts with individual components or elements and gradually builds up to form the complete system. It focuses on developing detailed components first and then integrating them to create higher-level structures. This method is useful for ensuring that each component works correctly before combining them into a larger system.

**Middle-out approach:** The middle-out approach strikes a balance between top-down and bottom-up methods. It involves starting from a middle-level perspective, neither too abstract nor too detailed, and then expanding both upwards and downwards. This approach aims to capture the essence of the system's architecture at an intermediate level of granularity, providing a holistic yet detailed view of the hardware structure.

By utilising these modelling approaches - top-down for a broad overview, bottom-up for detailed component design, and middle-out for an intermediate perspective - engineers can effectively design and represent multi-tier physical architectures of hardware systems in a systematic and comprehensive manner (“multi-tier Architecture,” 2024) (*Physical Architecture - SEBoK*, no date).

In the field of hardware system analysis and design, the structural view plays, therefore, a crucial role in understanding the physical architecture of modern technological systems. This view provides insight into the multi-level construction of these systems, which are characterised by their complexity and interconnected components. For example, in the design of a computer motherboard, the structural view helps to visualise the arrangement of various components such as the CPU, RAM, and connectors, and how they interact to ensure that the system functions efficiently. The structural view is essential for modelling methodologies as it serves as the basis for operational safety studies, allowing engineers to identify potential risks and vulnerabilities in the system.

The structural view encompasses various modelling methodologies, including bottom-up, top-down, middle-out, and concurrent approaches, each of which provides a unique perspective on the system architecture. The bottom-up approach involves building the system by integrating functional and material entities from the ground up. In contrast, the top-down approach deconstructs the system into detailed elements, providing a comprehensive understanding from the top of the hierarchy. The middle-out strategy starts from a middle point and expands to both macro and micro scales, while the concurrent approach considers all hierarchical levels simultaneously, providing a dynamic view of the system as visualized in the Figure 7 below.



## Structural view

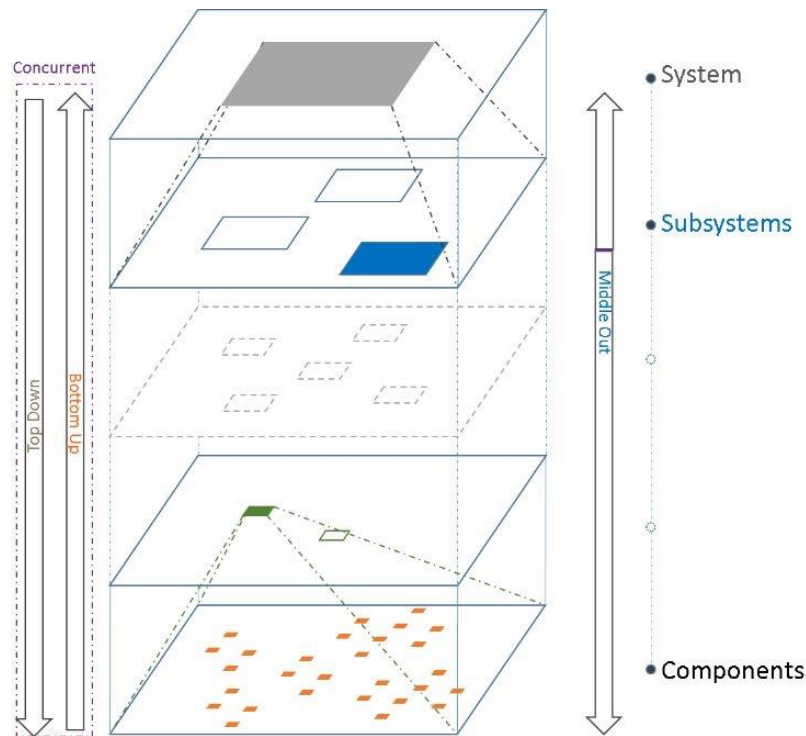

Figure 7. Structural breakdown for modelling approach

A bottom-up modelling methodology is a systematic approach to constructing a system by integrating its basic components and gradually building up to the complete structure. This method is often used in the design of hardware systems, such as integrated circuits, where individual components are assembled into a functional unit. An analogy to illustrate the bottom-up approach is building a house brick by brick, starting with the foundation and adding layers until the entire structure is complete. By focusing on the integration of components, engineers can ensure that each part work properly and contributes to the overall performance of the system (A. Cabrera *et al.*, 2014).

Bottom-up modelling allows for a detailed analysis of the role of each component within the system, helping engineers identify potential bottlenecks or inefficiencies that may affect the system's performance. This methodology is particularly useful in complex systems where the interactions between components are critical to the operation of the system. By understanding how each part contributes to the whole, engineers can optimise the design and improve the overall efficiency and reliability of the system.

The top-down modelling methodology involves breaking down a system into its individual components and analysing them in detail to understand how they work together to achieve the system's functionality. This approach is commonly used in software development, where the requirements of the system are defined first, and then the implementation details are worked out. The structural view analysis in hardware system design is not a static process but an evolving discipline

## Structural view

that adapts to the complexity of modern technologies. By using a combination of top-down, bottom-up, and middle-out methodologies, engineers can create designs that are not only efficient and reliable but also resilient to the unexpected challenges that arise during a system's lifecycle.

Let's look at an example in the realm of complex systems engineering as shown in Figure 8 Structural Hierarchy of an Autonomous Vehicle System, the autonomous vehicle system is a paradigmatic example, that encapsulates a multi-layered architecture that is both robust and adaptive. The system is represented by a hierarchical stratification that delineates its composition from the overarching system level down to the granular component level.

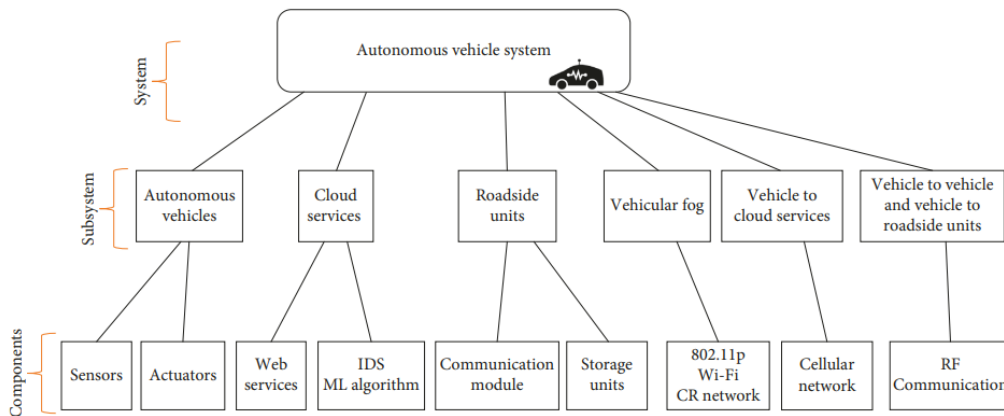

Figure 8. Structural hierarchy of an autonomous vehicle system

At the system level, we encounter the autonomous vehicle system in its entirety. It is an amalgamation of multiple interacting subsystems, synergistically working towards the overarching objective of providing autonomous navigation. This macro perspective is essential as it underpins the holistic functionality and end-to-end performance metrics of the system.

Descending to the subsystem level, complexity of the system is broken down and partitioned into discrete, function-specific units. Each subsystem, such as autonomous vehicles, cloud services, and roadside units, represents a cornerstone in the edifice of the system, handling specialised operations. The autonomous vehicle subsystem, for example, is entrusted with direct control and navigation tasks, while the cloud services are dedicated to extensive data processing and analysis operations, and roadside units facilitate communication infrastructures.

At the component level, specificity is paramount. This is where individual elements, such as sensors, actuators, and communication modules, come into play. These components are such as operatives that perform the atomic tasks within their respective subsystems, forming the operational backbone. For example, sensors collect real-time environmental data, actuators execute mechanical responses, and communication modules ensure seamless data exchange. The hierarchical distribution of the autonomous vehicle system is not just a theoretical construct; it is critical for both the development and operational phases. By decomposing the system into subsystems and then components, engineers

can focus on designing, testing, and optimising each fragment in isolation, and in conjunction with others. This methodology improves manageability, facilitates problem isolation, encourages iterative improvements, and supports scalability, and reliability issues.

## 2.5 Application of Structural View to Multiscale Modelling

Multiscale modelling serves as a method for creating mathematical and computational representations of complicated physical phenomena by exploring the interrelationships between models at different scales (E, 2011; Xia and Ruiz Pestana, 2023; ‘Multiscale modelling’, 2023). The core procedures involved in multiscale modelling encompass:

1. Determining and selecting the scales of importance to be included into the model
2. Formulating or selecting suitable models for each identified scale
3. Integrating these models to form a unified multiscale model

There are various methods for creating multiscale models, such as bottom-up, top-down, middle-out, and simultaneous strategies (Drira, 2017).

When it comes to the applying of the structural view in multiscale modelling, the structural perspective on complex systems highlights the importance of capturing the hierarchical structure and interactions between scales (Gao and Xu, 2021). These systems exhibit emergent behaviours that stem from the aggregated actions of components at smaller scales (Gao and Xu, 2021).

The structural view is essential for multiscale modelling as it provides a conceptual framework that links phenomena across different scales, from smaller mechanisms to larger-scale behaviours. This hierarchical organization enables the representation of complex systems and the interactions that lead to emergent properties (Drira, 2017; Gao and Xu, 2021). By clearly identifying relevant scales and developing corresponding sub-models, the structural view enhances the accuracy and completeness of models for physical, biological, and engineering systems. This approach improves the predictive capabilities of multiscale models by ensuring that all relevant interactions are accurately represented (Xia and Ruiz Pestana, 2023). It integrates various scales into a cohesive model, which is crucial for understanding and predicting the behaviour of complex systems (‘Multiscale modelling’, 2023). The structural perspective is foundational for developing robust models that can capture the intricacies of systems across different scales. The structural view is indispensable for multiscale modelling, enabling the integration of diverse phenomena into comprehensive and predictive models. This methodology not only advances our understanding of complex systems but also improves the fidelity and reliability of multiscale models (E, 2011; Drira, 2017; Gao and Xu, 2021).

### 2.5.1 Multiscale modelling for hierarchical stress analysis in complex engineering system

The quest to design robust complex systems requires a comprehensive understanding of stress propagation across various structural levels. Multiscale modelling is emerging as a quintessential

approach to dissecting this phenomenon, providing a granular yet holistic perspective from the system level down to individual components.

Multiscale modelling involves analysing stresses at different scales, integrating data from macro, meso, and micro levels. At the macro level, the overall structural integrity of the system is assessed, considering external loads and boundary conditions. The meso level focuses on the interactions between subsystems and components, examining how local stresses influence the overall behaviour of the system. Finally, at the micro level, material properties and microscopic stress distributions are analysed to understand their impact on the larger scales. By linking these scales, multiscale modelling allows for a more accurate prediction of system behaviour under various conditions. This approach helps identify potential points of failure and optimise the design for enhanced robustness and reliability. Furthermore, multiscale modelling facilitates the integration of advanced materials and innovative design strategies, enabling the development of next-generation engineering systems.

Multiscale modelling is a powerful tool for hierarchical stress analysis in complex engineering systems. It bridges the gap between different structural levels, providing insights that are essential for designing robust and reliable systems. As engineering challenges become more complex, the importance of multiscale modelling in stress analysis will continue to grow, driving advancements in the field.

- **System-level solutions**

Global stress distribution analysis: At the system level, multiscale modelling provides insights into the overarching patterns of stress distribution, enabling the identification of systemic vulnerabilities. This macroscopic analysis forms the bedrock of strategic planning for system architecture enhancements, promoting robustness against external perturbations.

Comprehensive system response simulations: Through high-level simulations, the model predicts the behaviour of the system under different stress scenarios. It assists in assessing the system's resilience and guides the implementation of modifications aimed at fortifying the system-wide integrity (Geut, 2020; Chen, Wang and Korsunsky, 2022; Kuś, Mucha and Jiregna, 2024).

Subsystem interconnectivity: The interdependencies across subsystems are scrutinized through the lens of multiscale modelling. It delineates how localized stressors can engender far-reaching impacts, fostering an understanding of potential cascading failures within the complex system fabric.

- **Subsystem-level solutions**

Localized stress management: At the subsystem level, the approach focuses on the dynamics within clusters of components, illuminating the intricacies of stress distribution within these microcosms and informing targeted stress mitigation interventions.

Redundancy and fail-safe design: Multiscale modelling identifies critical junctures within subsystems that benefit from redundancy, ensuring that a failure in one element does not compromise the integrity of the entire subsystem.

Seamless subsystem integration: The modelling process evaluates the cohesiveness of subsystem integration, identifying and reinforcing potential weak links at the interface to prevent them from becoming stress hotspots.

- **Component-level solutions**

Characterisation of material stress response: At the microscopic level, multiscale modelling assesses the stress response of materials, guiding the selection and design of component materials for improved durability and longevity (Smyth *et al.*, 2023).

Predictive component failure analysis: By modelling stress at the component level, the methodology enables the prediction of failure points within the system (Smyth *et al.*, 2023), prioritising monitoring and maintenance of high-risk components to prevent systemic effects.

Optimized component design: The knowledge gained from component-level stress analysis is critical for refining component designs (Smyth *et al.*, 2023), ensuring that each element not only withstands its load but also harmonises with the adjacent components to optimise stress distribution.

### 2.5.2 Integrative Approach for Diagnostic and Prognostic Systems through Structural Modelling

An all-encompassing philosophy for health management systems seamlessly weaves sensor data with analytical software, supporting the optimal utilisation of maintenance resources. This strategy hinges on two pillars: the precise prediction of potential issues or the estimation of the remaining operational period of essential components, and the swift, effective identification and isolation of the root causes after failure manifestations as shown in the figure 9. With accurate prognostications of system faults or failures, strategic planning for part replacements or refurbishment processes can be more effectively conducted (Vachtsevanos, 2006).

## Structural view

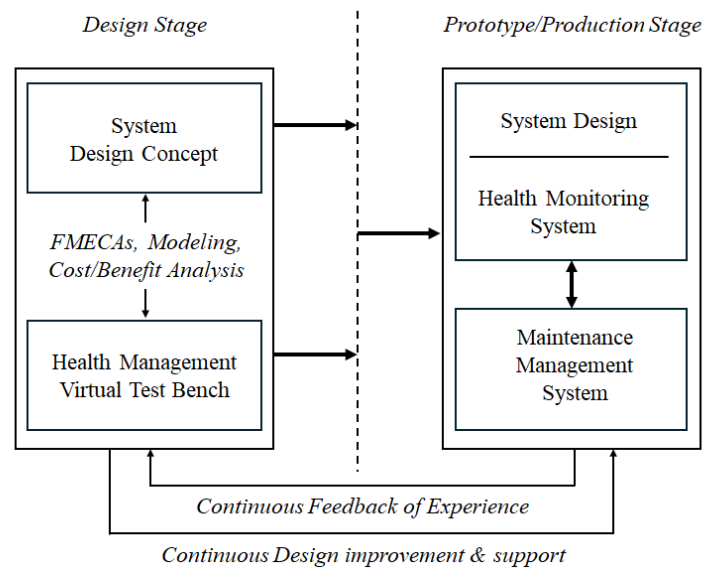

Figure 9. Design approach to health management.

The layered structure of diagnostic and prognostic systems leverages multiscale modelling to provide a comprehensive understanding of stress propagation across various structural levels. Multiscale modelling is an integrative approach that analyses stress dynamics from the system level down to individual components (E & Lu, 2011; Multiscale Modelling in Biomechanics, n.d.). This method employs cross-level analysis to ensure that stress dynamics are fully captured from the bottom up and top down, presenting a holistic view of the stress landscape.

By implementing hierarchical feedback mechanisms, insights at one level influence and enhance the modelling at other levels, fostering a dynamic, responsive modelling environment. This approach relies on the integration of complex data sets, managed through advanced computational tools that handle the vast amounts of information necessary for accurate multiscale modelling. Additionally, it embraces an iterative design philosophy, where empirical data and simulation results iteratively refine the models, leading to progressive enhancements in the system's design and operation (E & Lu, 2011).

The layered structure of diagnostic and prognostic systems, supported by multiscale modelling, provides a robust framework for hierarchical stress analysis. This integrative approach not only improves the accuracy of fault predictions but also optimizes maintenance strategies, ensuring the reliability and longevity of complex engineering systems.

## 2.6 Conclusion

In conclusion, Chapter 2 has highlighted the importance of the structural view in enhancing the reliability of complex systems through multiscale modelling. By breaking down systems into hierarchical components, this approach provides a clearer understanding of the interactions between subsystems and their elements. This structural framework is crucial for predicting system behavior and ensuring reliability across different scales, from the micro to the macro level. The chapter has also demonstrated how multiscale modelling helps improve system performance by providing more accurate insights into system architecture and behavior, particularly in fields like transportation and aerospace. Ultimately, the structural view forms the foundation for effective diagnostic and prognostic applications in systems engineering, contributing to the development of robust, efficient, and reliable systems.

The next chapter shifts focus to the temporal view, expanding on the insights gained from the structural perspective. By exploring how systems evolve over time, this chapter will examine the impact of lifecycle stages, degradation processes, and usage patterns on system reliability. The temporal view adds a dynamic dimension to multiscale modelling, allowing for a deeper understanding of how systems respond to varying conditions throughout their operational life. This approach complements the structural analysis by incorporating time-dependent factors, further enhancing the ability to predict and optimize system performance in complex environments

## Structural view



# Chapter III

## Temporal View

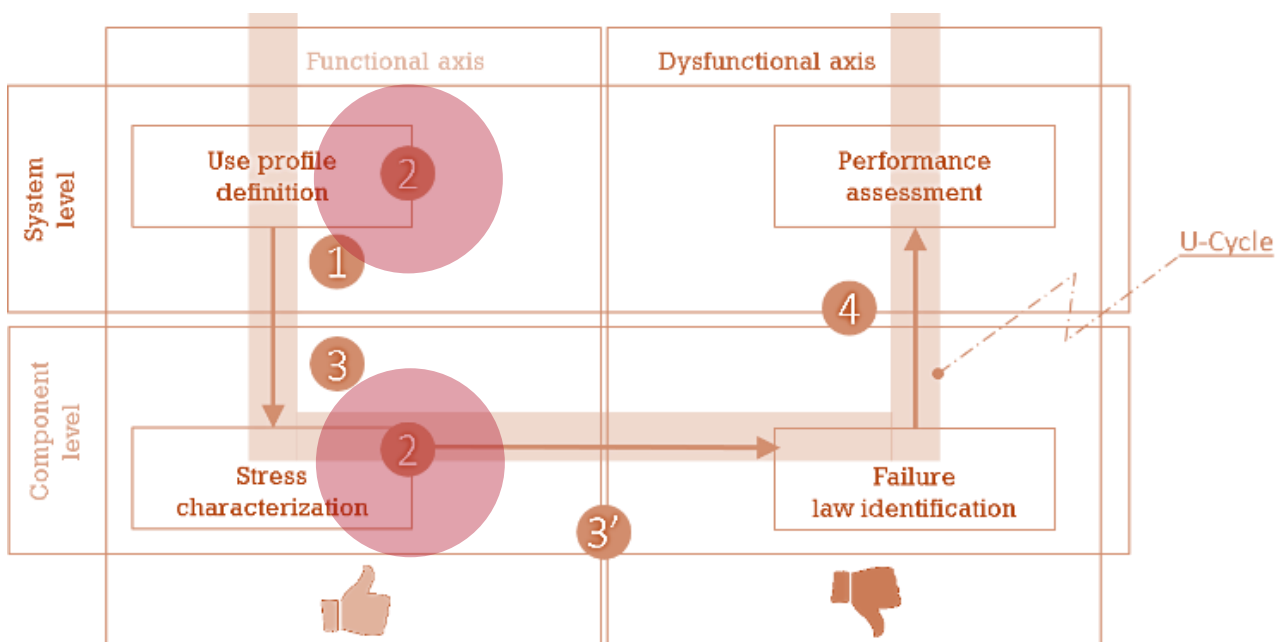

### 3.1 Introduction to Temporal

In the preceding chapters, this thesis introduced the importance of multiscale modeling for understanding the reliability of complex systems. Chapter II focused on the Structural View, which emphasized the hierarchical breakdown of systems into subsystems and components. This structural decomposition allows for a deeper understanding of how the organization and interactions between various elements affect system reliability.

The analysis in Chapter II highlighted the role of structural integrity in ensuring system robustness. Building on this foundation, Chapter III now shifts focus to the Temporal View. The Temporal View is critical in multiscale modeling as it examines how system behavior evolves over time. This view explores the dynamic aspects of system reliability, considering factors such as lifecycle stages, degradation processes, and operational use profiles. By analyzing how systems respond to varying conditions over time, we can better predict and prevent failures, thus ensuring long-term reliability. The discussion in this chapter will cover the application of the Temporal View to complex systems, exploring the interaction between time-dependent processes and system performance. This analysis will provide a holistic understanding of how temporal factors influence system reliability, complementing the structural insights from Chapter II.

The study of complex systems in engineering requires a rigorous analysis of both temporal and physical view. These two perspectives are fundamental to understanding the dynamics and structural interactions of systems operating at different scales and in different environments, from microscopic components in biomedical devices to large-scale infrastructures in urban development. Systems analysis is an interdisciplinary field that focuses on how complex engineering projects should be designed and managed. It involves breaking down a system into its component parts to understand the relationships and interactions between them. This process helps identify the goals, purposes, and requirements of a system, and can lead to the creation of better solutions ('Systems analysis', 2024)

In the context of complex systems, systems analysis examines the temporal and physical aspects of a system. The temporal dimension considers the dynamic behavior of a system over time, including its response to change, feedback loops, and emergent properties (Tang and Salminen, 2001). The physical dimension considers the structural components of a system, their interconnections, and how they interact at different scales (*Complex Systems Research | Design Eng. Lab | Oregon State Univ.*)

For example, in the design of a biomedical device, systems analysis would consider both the temporal aspects, such as the real-time response of the device to changes in a patient's condition, and the physical aspects, such as the interactions between microscopic components and how they are integrated into the larger system (*Complex Systems Research | Design Engineering Lab | Oregon State University*). Similarly, in urban development, systems analysis would examine the temporal dynamics of infrastructure systems, such as traffic patterns and energy usage, as well as the physical interactions between different components, such as transport networks and buildings. By rigorously analysing both the temporal and physical views of complex systems, engineers can develop a deeper understanding of their behavior and design more effective solutions that account for the inherent complexity (Tang and Salminen, 2001). This holistic approach is essential to address the challenges posed by complex systems in a wide range of engineering applications (*Dpt of Complex Syst. Eng. DISC/ISAE-SUPAERO*).

While previous studies have explored the role of the temporal dimension in system reliability, this work moves beyond a descriptive analysis by providing a structured methodology for integrating time-dependent failure models into multi-scale system reliability assessments. The proposed framework incorporates probabilistic approaches, such as Markov Chains and Bayesian Networks, to dynamically model system evolution over time. To demonstrate its practical application, a case study on aircraft power system reliability prediction is presented, highlighting how temporal variations in operational loads and environmental conditions influence system degradation and failure probability. Additionally, an iterative approach to reliability updating is proposed, enabling real-time adaptation of failure predictions based on operational data. By offering a quantitative and computational perspective, this chapter transitions from theoretical discussion to actionable methodologies, making the temporal view a functional and operational element in complex system reliability modelling.

### 3.1.1 Temporal View

The temporal perspective in multi-scale modelling is essential to capture the dynamics of systems as they evolve. This perspective is concerned with how systems respond to changes over time, including growth, degradation, and adaptation processes. Temporal analysis is particularly important in fields such as environmental engineering and aerospace, where the durability and phase changes of materials under different conditions can significantly affect the system performance. Recent advances in dynamic modelling techniques have improved the precision of temporal predictions in system behaviour, allowing for better planning and optimisation of operational strategies (Wang et al., 2023).

Recent advancements in dynamic modelling techniques, such as the use of multi-scale temporal networks (Zhu et al., 2022), have improved the accuracy of temporal predictions in system behaviour. These techniques allow for better planning and optimisation of operational strategies by providing a more accurate understanding of how the system will respond to changes over time (Song et al., 2023; X. Wang et al., 2023). For example, in the context of continuous sign language recognition, a multi-scale temporal network was proposed to extract temporal features at different scales, which improved the accuracy of the recognition compared to previous methods that used a fixed temporal receptive field (Zhu et al., 2022). Similarly, in engineering applications, multi-scale temporal models are being used to predict system responses to operational stressors, enabling more accurate failure predictions and enhanced system reliability.(Christensen et al., 2019).

In addition, the use profile of a system is an important part of the overall life cycle, which includes the development, production, and disposal phases. The use profile specifically refers to the different types of missions or usage patterns that the system will experience during its operational life. As the question explains, a system may have several types of missions, such as daily commuting, weekly shopping trips, occasional business trips, etc. Each of these different usage patterns corresponds to a different mission, and their cumulative effect makes up the overall usage profile (*Introduction — Mission Profile Format Documentation (Version 0.7.1)*). Understanding the use profile of a system requires, at a minimum, four levels of decomposition as shown in Figure 10 below.

## Physical View

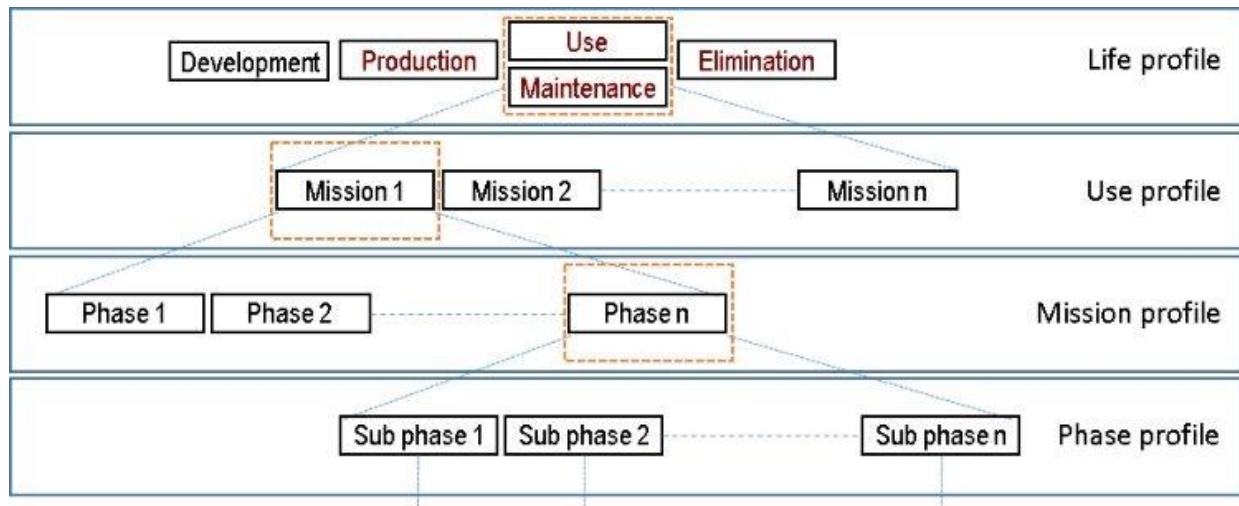

Figure 10. Time-dependent system profile

### Life profile

The life cycle profile is a high-level overview that covers all stages of a system's existence, from initial development to final disposal. It is an overarching perspective of a system's lifecycle and encompasses all the uses and conditions the system will experience throughout its operational life.

To establish a profile of life for an industrial system, the following steps are essential:

1. **Define the life cycle stages:** Outline phases such as design, production, installation, operation, maintenance, and end-of-life.
2. **Collect operational data:** Gather detailed information about operating conditions, usage cycles, constraints (technical, environmental), and maintenance schedules.
3. **Evaluate durability:** Analyze expected lifespan, wear, and potential failure modes.
4. **Schedule interventions:** Develop a proactive maintenance plan based on performance forecasts.
5. **Continuous updates:** Revise the profile based on new data from actual operation and evolving conditions.

This approach ensures optimal lifespan and system reliability.

### Use profile

The usage profile captures the series of tasks or types of use that the system will perform, for example for a vehicle, this could mean distinguishing between daily commuting, weekly shopping trips, weekend getaways, and occasional long-distance travel. It includes both the active use and breaks or rest periods (e.g., when the vehicle is parked), which can also affect the reliability of the system.

To define the use profile of an industrial system, the following steps are typically followed:

1. **Identify operating conditions:** Specify the environmental, mechanical, and operational parameters under which the system will function (e.g., temperature, pressure, vibration).

2. **Determine usage patterns:** Define the system's workload, frequency of use, duration of operational cycles, and variations in demand.
3. **Analyze performance requirements:** Assess the expected performance metrics, such as throughput, precision, or efficiency, based on typical and extreme scenarios.
4. **Consider maintenance cycles:** Include regular maintenance and potential downtime based on the system's operational intensity.

This helps optimize system operation and maintenance planning.

### Mission Profile

A mission profile details the sequence of activities and forms of system interrogation that occur during the execution of a mission. In the case of the vehicle, it would record the sequence of accelerations, decelerations, speed maintenance, and stops—both with the engine running and with the engine off. This profile helps understand how the system is specifically used during a single mission.

To define the mission profile of an industrial system, different key steps have to be followed:

1. **Determine mission-specific objectives:** Identify the purpose of the system for a given mission, such as operational goals or tasks to be completed.
2. **Specify mission conditions:** Define the environmental and operational conditions under which the system will perform during the mission (e.g., extreme temperatures, high loads).
3. **Establish duration and cycles:** Determine the expected duration of the mission and the number of operational cycles required.
4. **Assess performance and reliability:** Analyze the required performance metrics, such as precision, efficiency, and reliability during the mission.

This helps ensure the system meets the specific demands of the mission.

A mission profile can be defined as a comprehensive outline of the various phases and conditions a system, such as an aircraft, experiences during its operation. It is a critical tool in engineering that details the chronological sequence of operational states, environments, and performance requirements the system will encounter and must withstand. The mission profile informs design, testing, maintenance, and reliability assessments by providing the framework against which the system's capacities are matched to its expected tasks and challenges.

Mission profile can be defined as a system or component which is exposed to various events (or circumstances or situation) during its life cycle and perform a task to complete a typical mission (*Introduction — Mission Profile Format Documentation (Version 0.7.1)*). The term life cycle covers the manufacturing, testing, storage, transportation as well as the operational and passive use of a component, the term events cover specified time (years, months, hours, minutes or second), the environment (humid, hot, cold or rainfall), in which system performs its task and the term task covers structure of the system (car, truck, PV panel, satellite etc) or area or region (geographic location or

geographic range), planning (means the action of each task within a particular time period) (Sohrmann, 2020).

### Phase Profile

The phase profile breaks down each mission into smaller segments or tasks and provides a detailed description of the operational requirements during each phase of the mission. Each phase has different characteristics and requirements; for example, a vehicle's mission might be broken down into starting the engine, driving to the motorway, cruising at a constant speed, and finally, parking.

To break down the mission profile of an industrial system into elementary phases, the following approach is typically used:

1. **Identify operational stages:** Split the mission into distinct steps or functions, such as start-up, steady operation, peak load, and shutdown.
2. **Define conditions for each phase:** Outline the environmental and operational conditions specific to each stage (e.g., temperature, pressure).
3. **Specify performance requirements per phase:** Determine the system's performance expectations, such as power output or precision, for each phase.
4. **Analyse transitions between phases:** Assess how the system shifts between phases, focusing on any transient states or intermediate conditions.

This ensures accurate performance analysis and resource allocation during the mission.

Each type of profile represents a level of granularity for analysing the life cycle of the system. Understanding each profile is critical to designing a system that will perform reliably in its intended use and to establishing maintenance and replacement schedules that will ensure long-term functionality and safety.

It is crucial to characterise the usage the use profile, as it can have a significant impact on the reliability and performance of the system. Not only the periods of active use, but also the periods of rest or storage between missions need to be considered, as the conditions during these periods can also affect the reliability of the system (*Introduction — Mission Profile Format Documentation (Version 0.7.1)*). By understanding the detailed usage profile, including the frequency, duration, and environmental conditions of each mission type, engineers can better design the system to withstand the expected stresses and optimise its reliability over the entire life cycle (Musallam *et al.*, 2015) (Alexandrescu, 2023). The use profile is a key part of the overall lifecycle that needs to be carefully characterised and considered for in the design and validation of a system to ensure its reliable performance across the different usage patterns it will experience.

## 3.2 Temporal View in Multiscale Modelling

To dissect the temporal view within multiscale modelling, it is essential to first acknowledge the system's life profile, which comprises development, production, active use, maintenance, and

eventually elimination (*Multiscale Modelling in Biology*, 2017). This life profile is a temporal spectrum that encapsulates the entirety of a system's existence, from inception to decommissioning. Within this spectrum, the use profile emerges as a critical segment, encapsulating the operational phase inclusive of all tasks and support activities, such as usage, storage, and maintenance, up until the system's withdrawal from active service. Multiscale modelling techniques can integrate these temporal scales, from the development and production phases to the active use and maintenance phases, to provide a holistic understanding of the system's behaviour and performance over time (Verkhovtsev & Solov'yov, 2021; Ingólfsson *et al.*, 2023). By considering the system's life profile and use profile, multiscale modelling can capture the dynamic changes and interactions that occur across different temporal scales, leading to more accurate predictions and insights (*Multiscale Modelling in Biology*, 2017; X. Wang *et al.*, 2023).

Mechanistic models utilize mathematical formulations derived from the underlying biological processes of the host organism and its bioproduction activities. They utilize balances of mass and energy to characterize the dynamic nature of these processes (X. Wang *et al.*, 2023). Such models are instrumental in thoroughly investigating the causes behind variations in cellular growth and production. These investigations span various scales, ranging from genetic components to cellular functions, and up to the broader bioreactor environment, as shown in the Figure 11. The concept of spatial-temporal multiscale modelling is illustrated through three distinct spatial scales: the bioreactor, population, and cellular levels. At the bioreactor scale, the focus is on the collective dynamics that encompass mass transfer, flow dynamics, and the movements of bubbles and particles, which are typically analysed using computational fluid dynamics (CFD) models. At the population scale, the emphasis shifts to the growth patterns, competitive dynamics among cells, and their interaction with their surroundings. Lastly, at the cellular scale, the models forecast the complex intracellular activities, including metabolic networks, signal transduction pathways, and gene regulatory frameworks (X. Wang *et al.*, 2023).

Understanding the intricate dynamics of **complex systems** involves dissecting each segment of operation, often referred to as 'missions.' For example, in the context of transport systems, these missions can be imagined as distinct journeys undertaken by a vehicle—each with its own starting point and destination, encompassing varied activities such as daily commutes, errands, or extended road trips. Each mission is characterized by a 'temporal footprint,' a specific timeframe that captures its active duration from start to finish. While transport systems serve as a clear example, this concept of missions and temporal footprints can be applied to other complex systems where operations are similarly structured and time-dependent. Beyond active use, the silent intermissions of rest also play a crucial role in shaping the vehicle's endurance. These intervals of inactivity, where the vehicle remains parked and unused, are pivotal as they expose the system to external factors like weather, which could influence its long-term reliability.



## Physical View

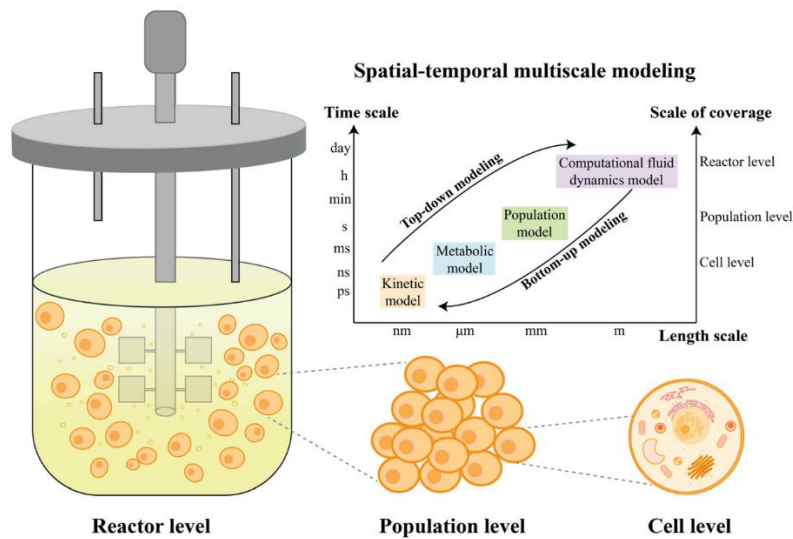

Figure 11. Spatial-temporal multiscale modelling (Wang et al., 2023)

To delve deeper into the life of a vehicle during missions, we categorize its activity into 'phases' and 'sub-phases,' constructing a detailed 'mission profile.' This profile is akin to a narrative of the vehicle's life, highlighting varied operational states—accelerations, cruising, pauses, and shifts in performance levels. This detailed breakdown serves as a map, revealing the stress points where the vehicle is most vulnerable to wear and tear. With this roadmap, engineers and designers can craft precise enhancements and maintenance schedules that target these critical moments, effectively fortifying the vehicle's performance and reliability across its lifespan. By examining the complexities of vehicle missions through this granular lens, we gain the foresight to preemptively address potential failures, ensuring a smoother and more dependable journey for every user.

In the domain of reliability engineering, the temporal perspective constitutes a foundational element for the construction of dynamic, multiscale models. It offers a systematic framework to trace a system's life cycle, delineating the intricate tapestry of time-bound events and activities. By mapping the broad life profile of a system onto its granular sub-phases, this approach provides a comprehensive overview of the system's physical states and behaviours throughout its operational tenure. Such a detailed chronology is indispensable for predicting and preempting failures within complex systems.

In our pursuit of understanding the resilience of these systems, we recognize that each temporal layer holds a key to unlocking patterns of use and wear that, when modelled accurately, can forecast and mitigate potential points of failure before they manifest. This temporal granularity, when harmonized with the system's physical realities, offers an enriched narrative that not only charts but also adapts to the ebb and flow of operational demands. It is within this interplay of time and physics that we find the levers to enhance the reliability and longevity of complex systems. In subsequent sections of this thesis, we will delve into the confluence of the temporal and physical dimensions, aiming to weave together a cohesive narrative that captures the full spectrum of a system's operational reliability over its lifetime. This synthesis is not merely academic; it is a critical lever for the strategic planning of maintenance, the optimisation of performance, and ultimately, the extension of the system's functional horizon.



### 3.2.1 Understanding System Reliability through a Holistic Approach

The analogy of a complex puzzle is an insightful way to think about system reliability. We make an excellent point that we need to consider both the interconnected nature of the system, as well as the individual pressures and stresses on each component piece. This holistic perspective is crucial for enhancing system reliability and performance.

#### Examining the Whole and the Parts

- The whole system: Viewing the system as an integrated puzzle allows us to understand how the various components fit together and interact. This macro-level understanding is essential for identifying systemic vulnerabilities and interdependencies ('Effective DER Management Requires a Holistic Approach to Reliability Analysis Underpinned by GIS and BI Tools | UDC, LLC.', 2023).
- The individual pieces: Simultaneously, we must analyze how each individual component is affected by the pressures of use and operation. This micro-level examination provides crucial insights into the failure modes and stress points of specific parts ('Effective DER Management Requires a Holistic Approach to Reliability Analysis Underpinned by GIS and BI Tools | UDC, LLC.', 2023).

### 3.2.2 Incorporating the Temporal Dimension

The emphasis on tracking usage over time is also a key factor. Systems do not exist in a static state - they are dynamic, with changing conditions, usage patterns, and degradation over their lifecycle (Xia and Qi, 2022). Incorporating this temporal view allows us to:

- Identify emerging issues before they escalate
- Predict future failure points based on historical trends
- Proactively maintain and optimize the system for long-term reliability

### 3.2.3 Enhancing System Reliability

By combining this holistic, multi-faceted approach - looking at the system as a whole, the individual components, and how they evolve over time (Zio, 2016) - we can develop a more comprehensive and nuanced understanding of system reliability. This enables us to:

- Anticipate and mitigate potential failure modes
- Optimize system design and maintenance strategies
- Improve overall system performance and resilience

In essence, this analogy highlights the importance of adopting a systems-level perspective that accounts for both the interconnected nature of the puzzle and the unique pressures on each piece (Zio, 2016). This integrated view is a powerful tool for enhancing the reliability and long-term success of complex systems.

### 3.3 Overlay of temporal view in U-cycle approach

In the context of complex systems engineering, particularly within the U-Cycle approach, the Temporal View (Spot 2) focuses on the operational use profiles of a system. These use profiles include both mission profiles and inter-mission phases, that are critical to defining how systems respond under varying operational conditions. This analytical perspective is critical because it directly impacts the dimensioning of systems, ensures that they meet expected availability standards through robust characterisation as shown in the Figure 12 the overlay of temporal view at spot 2.

The Figure highlights Spot 2 within the functional axis, specifically pinpointing the 'Use Profile Definition' within the U-Cycle approach. This step is a central part of the Temporal View.

The 'Use Profile Definition' at point 2 is where the mission profiles are articulated. These profiles encapsulate the expected system-level operational scenarios and are a foundational step for stress characterization, which occurs further downstream in the U-Cycle process. The blue arrows descending from the 'Use Profile Definition' represent the flow of information to the 'Stress Characterization' at the component level. This visualization reinforces the concept that the defined use profiles at the system level must be carefully translated component-level stress profiles. Such detailed characterization ensures that each component is designed and tested for the specific demands it will face during different operational phases. In addition, the transition from the system level to the component level across the functional axis suggests a hierarchical breakdown of operational requirements, emphasizing that while the system as a whole may face certain conditions, individual components might experience stresses that vary in magnitude and nature.

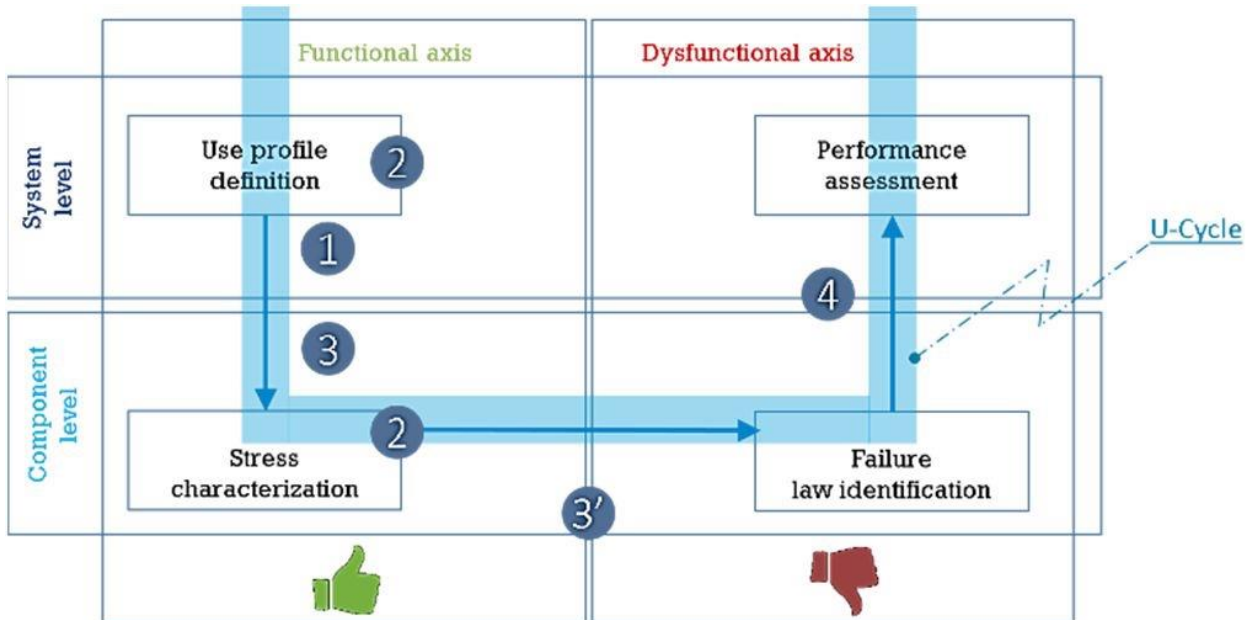

Figure 12. Superimposition of Temporal view (Spot 2)

In the context of the U-Cycle, Figure 12 illustrates a cyclical feedback loop where insights from the dysfunctional axis feed back into the functional axis. Specifically, the processes of 'Performance Assessment' and 'Failure Law Identification' provide crucial feedback for refining the definitions of

use profiles and improving stress characterizations. This iterative cycle ensures continuous system evaluation and enhancement, where failures and performance issues drive ongoing improvements in system operation and reliability.

This visual representation is particularly helpful because as it illustrates the integrated nature of the U-Cycle approach and essential role of the temporal view in achieving a comprehensive understanding of operational stresses and reliability at all levels of a system. It visually supports the notion that each phase in the process is critical and that the assessment and management of system reliability are dynamically linked through the U-Cycle.

Mission profiles are defined for each level-system, subsystem, and component-based on the specific requirements and operational conditions expected at each hierarchical level (Product Mission Profiling in Practice). The importance of accurately defining these profiles lies in their ability to influence design considerations related to reliability, safety, and maintainability (*Introduction — Mission Profile Format Documentation*). Such definitions are important for several reasons:

- **Reliability and Safety:** By characterizing the mission profiles, engineers can make informed decisions about component selection, system architecture (including redundancies), and the strategic sensor placement (*Introduction — Mission Profile Format Documentation (Version 0.7.1)*). This approach ensures that safety and reliability are built into the system design.
- **Maintainability:** Effective mission profiles help in designing systems with better maintainability characteristics such as accessibility, modularity, standardization, and ease of disassembly and reassembly.
- **Support systems:** They also help plan for adequate support infrastructure, including spare parts, tools, and maintenance facilities.

### *Typical example of mission profile for aircraft*

The figure 13 shows a simplified graphical representation of a typical aircraft mission profile, which describes the major operational phases that an aircraft goes through during a flight. A mission profile is a detailed scenario that specifies the operational requirements an aircraft must meet, including weight, fuel, payload, range, speed, altitude, loiter time, and other factors. It is a critical part of the conceptual design process, because it establishes the size and performance requirements that the aircraft design must meet (Denham *et al.*, 2023).

Key elements of a mission profile include:

- Launch, Take-off and initial climb
- Climb to cruise altitude
- Cruising at altitude
- Descent and landing
- Potential detours or diversions
- Consideration of non-nominal conditions such as engine failure (Denham *et al.*, 2023)

Mission profiles are defined in airworthiness certification standards and regulations (Denham *et al.*, 2023). An object-oriented approach can facilitate the creation and specification of mission profiles

(Rivera, 1993). By defining the mission profile, conceptual aircraft design can incorporate increasingly detailed modelling of the flight profile to support sizing analysis and design constraints (Denham *et al.*, 2023). This allows the aircraft to be optimized for its intended mission objectives (Denham *et al.*, 2023). In summary, the mission profile is an essential tool in aircraft design that comprehensively defines the operational requirements and scenarios that the aircraft or complex system must be able to perform. It informs the sizing, performance, and capabilities that aircraft design must provide.

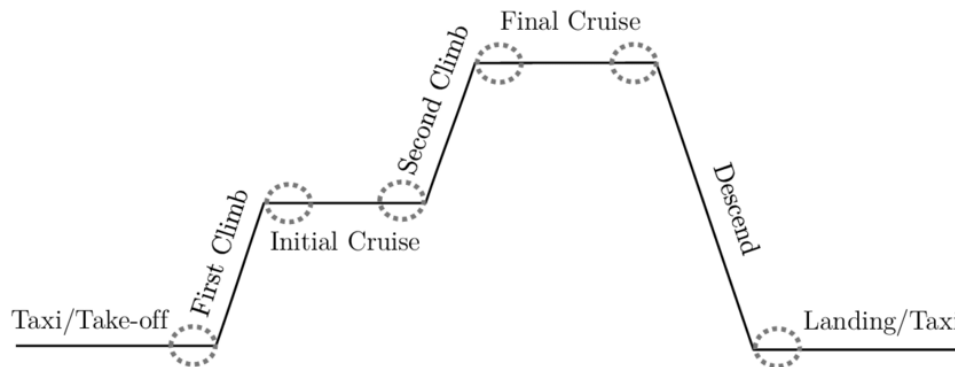

Figure 13. Typical example of mission profile of aircraft

1. Taxi/Take-off: The aircraft moves from the gate to the runway and performs the take-off. This phase includes the acceleration along the runway and the initial climb after lift-off.
2. Initial Climb: After take-off, the aircraft ascends to a predetermined altitude. This phase involves significant engine thrust and structural loads due to climb dynamics.
3. Initial Cruise: Once the initial altitude is reached, the aircraft levels off for a cruise. This phase is typically less demanding than the climb but still requires consistent engine performance to maintain altitude and speed.
4. Second Climb: The airplane may continue to climb to reach a higher cruise altitude. This phase is similar to the first climb but may occur at different environmental and aircraft load conditions.
5. Final Cruise: During this phase, the airplane cruises at a steady altitude and speed, which is generally the longest phase of the flight and involves sustained operational conditions.
6. Descent: The aircraft descent altitude in preparation for landing. This phase involves reducing speed and managing structural loads as the aircraft approaches the ground.
7. Landing/Taxi: The final phase includes touchdown, runway deceleration, and taxiing to the gate. This phase can impose significant stress on the landing gear and structural components due to the impact forces and braking.

Each of these phases has different operational requirements and stress profiles for the aircraft. For example, take-off and landing are typically more demanding in terms of performance and structural stress, while cruise phases are characterized by sustained operating conditions that can impact long-term wear and fatigue. Understanding and characterizing these phases is essential for optimizing aircraft design, maintenance schedules, and operational procedures to ensure safety and efficiency throughout the aircraft's service life.

### 3.4 Conclusion

The Temporal View plays a critical role in understanding and enhancing the reliability of complex systems by examining how they evolve over time. This chapter has explored the application of temporal analysis in multiscale modeling, highlighting its importance in capturing the dynamic behavior of systems throughout their life cycle. By focusing on key concepts such as life profiles, use profiles, and mission profiles, we have demonstrated how time-dependent factors directly influence system performance, degradation, and ultimately, reliability.

Through the integration of the U-Cycle approach, the Temporal View enables a holistic assessment of system reliability, allowing for better prediction of failure modes and more efficient planning of maintenance strategies. This iterative feedback process between functional and dysfunctional views ensures that systems are continuously evaluated and refined, leading to ongoing improvements in their operational reliability.

As we transition into the next chapter, the focus shifts from the temporal to the physical view, where we will delve into the material properties and physical interactions that underpin system performance. This shift allows us to examine how physical stressors—such as mechanical, thermal, and environmental forces—interact with the temporal dynamics already explored. Together, these dimensions will offer a comprehensive view of system reliability, enabling a more robust and resilient design approach for complex systems

# Chapter IV

## Physical View

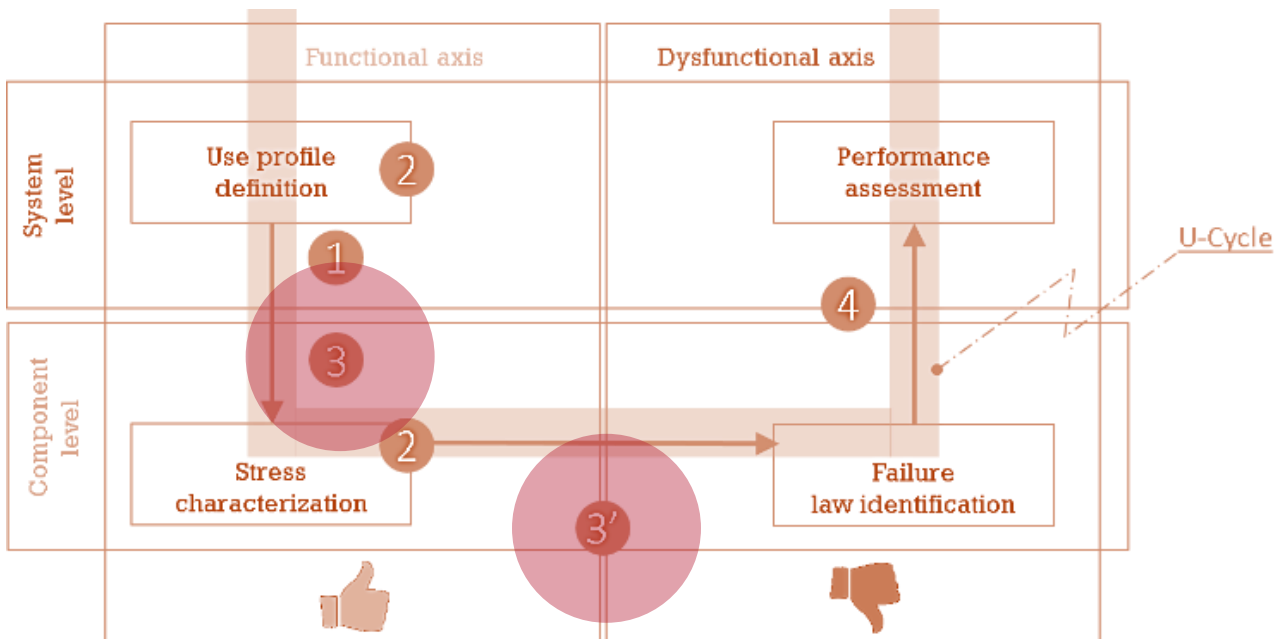

## 4.1 Physical View

Having explored the structural and temporal dimensions of system reliability in the previous chapters, **Chapter IV** now turns to the **physical view**. While the **structural view** analyzed the hierarchical organization of system components and the **temporal view** focused on how system behavior evolves over time, the **physical view** shifts the focus to the material properties and physical interactions that underpin system performance and resilience.

This chapter delves into how various physical phenomena—such as mechanical stress, thermal effects, and material degradation—affect the reliability of complex systems. By examining these tangible aspects at different scales, from the microscopic to the macroscopic, we can better understand how components endure operational stress and how their physical integrity influences overall system reliability. The **physical view** not only complements the previous discussions on structural and temporal factors but also adds a critical layer of insight into the material and environmental constraints that impact system longevity. In the following sections, we will explore how these physical aspects are modeled within the multiscale framework and how they contribute to the overarching goal of enhancing system reliability.

On the other hand, the physical view focuses on the material aspects and the interaction between components at various scales. It examines how the physical properties of materials, such as conductivity, strength, and thermal stability or any other characteristics, contribute to the system's overall functionality and resilience. Understanding these physical interactions is crucial for designing more reliable and efficient systems. For instance, in semiconductor manufacturing, the physical properties at the nanoscale level can dramatically influence the electrical performance and integrity of the final product (Li et al., 2022).

Accurately modelling these nanoscale phenomena and their impact on the macroscale behaviour is essential for optimising semiconductor device design and manufacturing processes (Alber et al., 2019). The physical view complements the temporal perspective in multiscale modelling by providing a deeper understanding of the underlying mechanisms driving system behavior. Together, these two perspectives enable a more comprehensive and accurate representation of complex systems, leading to better planning, optimisation, and decision-making across a wide range of applications (E, 2011).

Integrating the Temporal and Physical Views is not merely a theoretical exercise but a practical necessity. For example, in the study of infrastructure resilience, the physical degradation of materials over time under environmental stressors must be considered to accurately model and predict system longevity and failure rates (Johnson and Smith, 2021). Similarly, in biomedical engineering, the wear and tear of implant materials within the human body involve both a physical breakdown and a temporal dimension of how quickly these processes occur (Doe et al., 2024). These views are interdependent; temporal dynamics are influenced by physical changes, and physical assessments often require a temporal understanding to predict when system components might fail or need maintenance. The following sections will delve deeper into these integrations, employing analytical techniques to understand and model the complex interplay between time and physicality in multiscale systems.



While the modelling scheme for the physical view is well-defined and categorized into deterministic and stochastic domains, its practical application requires an illustrative case study to demonstrate how these models are implemented in real-world scenarios. To bridge this gap, this chapter will introduce a case study on the impact of thermal stress on aircraft power electronics reliability. By integrating finite element analysis (FEA) for deterministic modelling and Monte Carlo simulations for stochastic evaluation, this case study will showcase how physical interactions at the component level influence system-wide reliability. This addition ensures that the physical view is not just conceptually detailed but also operationally applicable, reinforcing its role in multi-scale reliability modelling.

### 4.1.1 Physical view Multiscale Modelling

In multiscale modeling, the 'physical view' focuses on the actual material and structural aspects of a system and how they respond to different types of stress over time. To understand system failures, one must consider the malfunctions at the smallest scale – the level of the individual components (Lytton et al., 2017). This involves drilling down through the layers of the system – from the entire system to subsystems, and then to the individual components – to identify the specific stresses associated with how the system is used at each level, such as during various phases of a mission, operation (Lytton et al., 2017) (Schieber & Hütter, 2020).

However, understanding these stresses at every level is not enough to fully explain why components fail. We need to add another layer to our analysis – the physical phenomena that occur within the components themselves due to their different modes of use. This might include wear and tear from mechanical friction, thermal degradation from heat, or fatigue from repeated loading and unloading (Aghaei et al., 2022). These physical phenomena are what ultimately lead to the 'original dysfunctions' – the initial points of failure from which larger system failures can emerge (Aghaei et al., 2022).

To put it another way, think of a system as a complex puzzle where each piece is subject to different pressures depending on how it's used. If we want to prevent the puzzle from falling apart, we need to look not only at how the pieces fit together and move as a whole but also at how each individual piece is affected by the pressures of use. By combining this understanding with our temporal view, which tracks usage over time, we can create a more complete and nuanced model of why systems fail and how to prevent these failures, thereby enhancing system reliability and performance.

### 4.2 Overlay of the Physical view in U-cycle approach

The Physical View is essential for understanding how system functionality is influenced by material and structural responses to various physical stresses over time. When integrated within the U-Cycle framework, the Physical View allows for a comprehensive analysis of how these stresses accumulate and how they propagate through the system, from the system level down to the component level. By focusing on the tangible behaviors and interactions within the system, the Physical View plays a pivotal role in determining the robustness and reliability of system design and operation.

## Physical Stress Accumulation and Propagation

The U-Cycle framework depicted in Figure 15 illustrates how physical constraints are introduced at the system level, typically defined through the use profile (spot 1). The use profile outlines the



expected operating conditions under which the system will function, including the types and magnitudes of stresses—mechanical, thermal, electrical, etc.—that the system and its components will experience during operation.

As these stresses propagate downward to the component level (spot 2), they are subjected to stress characterization, where each component is analyzed to understand how it will endure these loads. Different components within the system are subjected to varied levels of stress depending on their specific role and position in the system, and their ability to withstand these stresses without failing is a critical factor in overall system reliability.

At this stage, it is important to differentiate between stress accumulation and its transformation into reliability performance. The accumulation of stress refers to the total load that a component endures over time. This can include cyclic loading, thermal fluctuations, or continuous operational wear. The transformation into reliability performance occurs when we analyze how close these cumulative effects are to the permissible threshold of each component. Every component has a specific resistance limit, beyond which it transitions from functional to dysfunctional.

### **Transition from Functional to Dysfunctional View**

As shown in Figure 14, the U-Cycle framework illustrates the transition from the functional axis to the dysfunctional axis. The functional view is concerned with how the system and its components perform under normal operating conditions, while the dysfunctional view addresses what happens when stress levels exceed permissible thresholds, leading to failure.

After stress characterization (spot 2) at the component level, the next phase is the identification of failure mechanisms (spot 3'). This is the moment where accumulated stress begins to push components beyond their designed resistance thresholds. At this point, the system moves from a functional state to a dysfunctional state, where components can no longer perform as expected. This failure may manifest as cracks, wear, thermal degradation, or mechanical deformation, depending on the nature of the accumulated stress.

Finally, the dysfunctional axis leads to failure law identification (spot 4). This step involves identifying the specific conditions under which the system or component failed and evaluating how this failure affects overall system performance. The aim is to map out a comprehensive understanding of the failure modes, enabling engineers to predict and prevent future occurrences through design improvements or enhanced maintenance strategies.

## Physical View

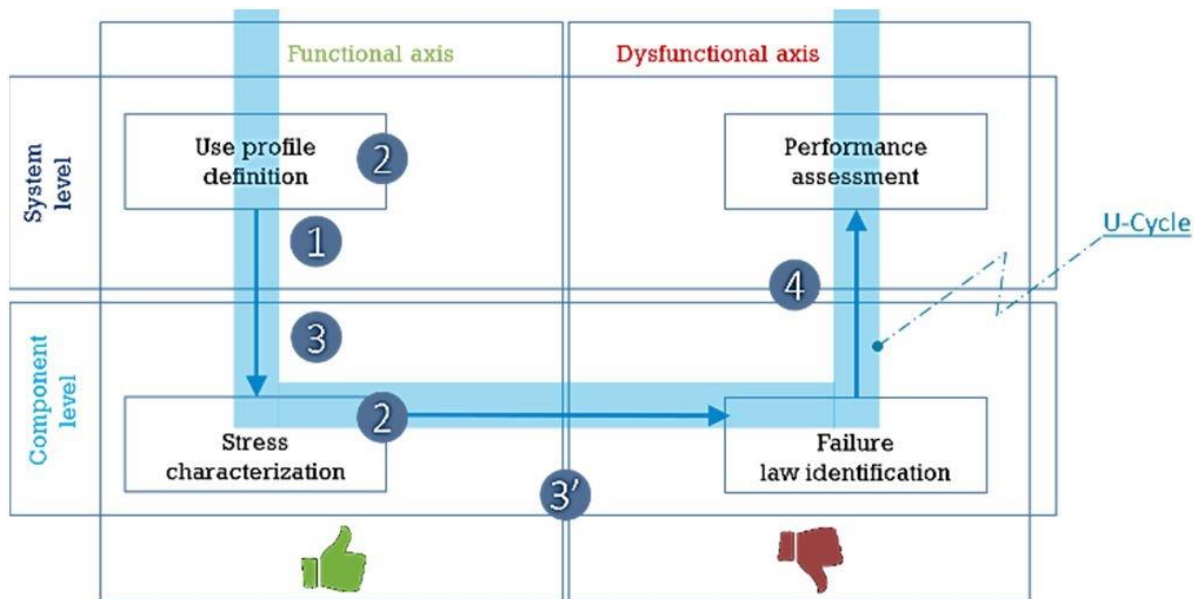

Figure 14. Overlay of Physical view (Spot 3)

### ***From Stress to Reliability Performance***

The U-Cycle framework not only helps us understand how physical constraints accumulate and propagate but also demonstrates how they transform into reliability performance metrics. By tracking how physical stressors, such as mechanical and thermal loads, accumulate over time, we can predict the likelihood of failure at different levels of the system. These predictions are critical for assessing the overall reliability of the system.

Hence, the physical view within the U-Cycle framework allows us to move from a simple analysis of system functionality to a deeper understanding of how physical stress influence's reliability. By examining how stress accumulates at the component level and how it propagates through the system, we can better predict failure points and design more reliable systems.

#### 4.2.1 Analysing the Impact of Mission Profiles on System Stresses

The operational stresses imposed on a system vary significantly across different phases of a mission. For instance, the demands during a flight phase in aerospace are considerably higher than during taxiing. Similarly, in rail transport, a moving train experiences different stresses compared to when it is stationary yet powered. Understanding these variations is critical for several reasons:

- Qualification and quantification of reliability: Mission profiles help in the physical characterisation of test benches and in identifying appropriate testing protocols, which are essential for validating the reliability and durability of systems under real-world conditions (Peyghami et al., 2019; Warmuth, 2018).

- Forecasting and methodology development: The Temporal View encourages the development of forecasting techniques based on empirical data and historical usage patterns. For example, in the case of an aircraft, variables like cruising altitude and jet stream direction are crucial for defining the mission profile. Similarly, for ground vehicles, factors such as traffic conditions and route profiles need to be considered (Hirler et al., 2019; Warmuth, 2018).

### 4.2.2 Transition of Mission Profiles Across Hierarchical Levels

The superimposition of the temporal view within the U-Cycle approach also involves analysing how mission profiles transition across hierarchical levels of a system. This analysis is pivotal because the operational demands on a system do not necessarily equate to uniform stress across all components. Identifying the appropriate methods to determine how operational demands trickle down from the system to the subsystem and component levels is a complex task that requires a combination of theoretical knowledge, empirical data, and sophisticated analytical techniques. Here are several approaches and methodologies that can be employed to achieve a comprehensive understanding of stress distribution across various system levels:

1. **Hierarchical Task Analysis (HTA)**  
HTA is used to break down the system's operation into tasks and subtasks, which can then be analyzed to understand the demands at each level. This approach can help in identifying the specific operational scenarios where components are likely to be stressed (Diamond et al., 2007).
2. **Computer-Aided Engineering (CAE) Simulation**  
High-fidelity simulations using Finite Element Analysis (FEA), Computational Fluid Dynamics (CFD), and other CAE tools can predict stresses and strains on individual components under various operational conditions. Simulations can model different mission profiles and assess the response of the system and its components (Diamond et al., 2007).
3. **System Reliability Modeling**  
Employing reliability modeling methods such as Fault Tree Analysis (FTA), Failure Modes and Effects Analysis (FMEA), or Reliability Block Diagrams (RBDs) can help in understanding how failures might propagate through a system and impact component-level stresses (Diamond et al., 2007).
4. **Empirical Testing and Data Acquisition**  
Field tests and experimental data collection provide real-world insights into the operational stresses experienced by the system. This data can be used to validate simulation models and to better characterize the stress profiles for different mission phases (Diamond et al., 2007).
5. **Statistical Analysis and Machine Learning**  
Applying statistical methods and machine learning algorithms to large datasets can reveal patterns and correlations between operational conditions and component stress levels.

Predictive models can then be developed to forecast stresses under various use profiles (Diamond et al., 2007).

### 6. Sensitivity Analysis

Conducting sensitivity analysis on various system parameters allows for the identification of components that are most affected by changes in operational profiles. This helps in prioritizing which components need more detailed stress characterization (Diamond et al., 2007).

### 7. Experience Feedback (EF) and Case Study Analysis

Analyzing historical data and case studies of system failures and performance can provide insights into stress distribution patterns. EF involves collecting data on system performance over time to identify typical and atypical stressors (Diamond et al., 2007).

### 8. Expert Elicitation

Consulting with experienced engineers and experts in the field can provide qualitative insights into the stress characterization of components. Expert elicitation can be used to supplement quantitative data, particularly when empirical data is scarce (Diamond et al., 2007).

Despite the critical importance of these considerations, there is a notable gap in academic research regarding the propagation of operating constraints across different structural levels in transport systems. Addressing this gap is essential for advancing the U-Cycle approach and enhancing the reliability assessments of transport systems, which would benefit from a more granular understanding of use profile variability. The temporal view in the U-Cycle approach provides a systematic framework for defining and analysing mission profiles at various system levels. By understanding and applying these profiles, engineers can better design, maintain, and support complex systems, ultimately enhancing operational reliability and safety. The ongoing development of methodologies to characterize these profiles and their impacts at different system levels remains a vital area of research, with significant implications for the future of systems engineering in transportation and beyond.

## 4.3 Physical constraints and their induction

The physical view recognizes that every system operates under certain conditions that impose constraints as shown in Figure 15.

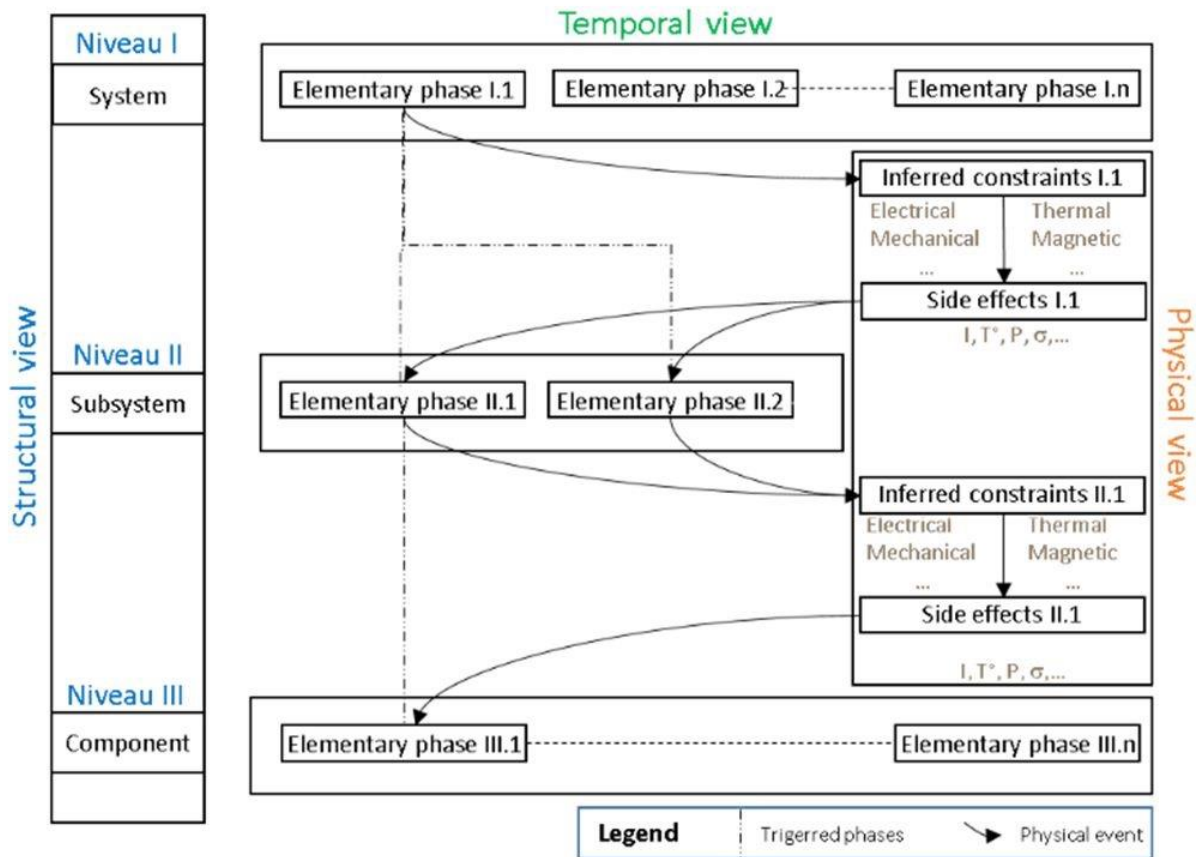

Figure 15. Inferred physical phenomena.

These constraints can be:

- Electrical: Such as voltage or current which can lead to electrical stress or overheating.
- Magnetic: For example, magnetic fields that affect components such as sensors or cause electromagnetic interference.
- Mechanical: Such as vibration, wear from moving parts, or static loads.
- Thermal: Heat generation that may exceed the material's tolerance.
- Hygrometric and Barometric: Effects of humidity and pressure that can affect sensitive equipment or materials.

Any phase of operation can induce these conditions, resulting in different states that can be quantified by variables such as pressure, temperature, and mechanical stress.

#### 4.3.1 Propagation of Effects

These constraints do not act in isolation; they propagate through various levels:

- Internally: From higher levels of structural organization down to the elementary components.
- Externally: From environmental factors acting on the system.
- Laterally: From neighbouring units within the same structural level.
- From Below: Upwards from lower levels of the structure.

The consequences of these propagating effects are measured by their magnitude (how much they exceed resistance thresholds), their coupling (how different stresses combine), and their fatigue (how repeated stresses accumulate over time).

### 4.4 Modelling Framework

In multiscale modeling, the physical view provides a crucial perspective that focuses on how components at different scales respond to various physical stresses. The modelling framework for the physical view must integrate both deterministic and stochastic approaches to capture the complexity of physical interactions and their impact on system reliability.

Deterministic models are used to predict specific system behaviors under given conditions, allowing for precise simulations of how materials and components behave under stress. Stochastic models, on the other hand, account for the inherent variability and uncertainty in system behavior, recognizing that real-world applications often include factors that cannot be completely controlled or predicted.

This dual-framework approach ensures that the physical phenomena influencing system reliability are accurately represented. It also enables engineers to understand not only how a system will behave under nominal conditions but also how it might respond to unexpected stresses, providing a comprehensive understanding of system performance and potential failure points.

#### 4.4.1 Modelling the physical view

The physical view in this framework plays a crucial role in understanding how system components behave under various stresses—such as mechanical, thermal, electrical, and environmental—throughout their operational life cycle. Each of these stresses can have a cumulative effect, which may progressively degrade the performance and integrity of the system if not properly modeled and managed.

To accurately model these physical phenomena, the system is broken down into its constituent components, and the interactions between these parts are analyzed to determine how stress propagates and accumulates throughout the system. This detailed modeling requires understanding how stresses imposed on one part of the system can impact neighboring components and how this chain of effects contributes to system-wide reliability or failure.

At the core of this modeling approach are simulations that predict how materials and components will react to specific loads and environmental conditions. Techniques such as finite element analysis (FEA) for mechanical stresses, thermal analysis for heat distribution, and electrical modeling for current flow and insulation breakdown are commonly used to simulate component behavior under operational stress. FEA, for instance, allows engineers to break down complex geometries into smaller, finite parts and predict how each part will behave under mechanical loads, while thermal analysis can simulate heat transfer across components, helping identify critical points where overheating might lead to degradation or failure.

## Physical View

The cumulative effect of these stresses is especially important to model. Stresses on a component rarely occur in isolation; rather, they often accumulate over time, particularly in systems exposed to cyclic loading, repeated thermal expansions, or constant environmental exposure. Research in material fatigue (e.g., Wang et al., 2023) shows that even small, repeated stresses can lead to microcracks that grow over time, eventually causing significant component failure. Similarly, thermal fatigue—the repeated heating and cooling of materials—can lead to material degradation, as seen in semiconductor components and mechanical parts exposed to fluctuating temperatures (Zhu et al., 2022).

Additionally, the temporal dimension is integrated into this modeling process to capture how physical stresses evolve over time. For instance, fatigue due to repeated loading cycles, material degradation from long-term thermal exposure, or environmental factors such as humidity and pressure all affect the durability of components in the long run. Multiscale modeling, which considers the interactions between different scales—ranging from microscopic phenomena (e.g., atomic structures of materials) to macroscopic behaviors (e.g., component deformation)—is necessary to fully understand the cumulative effects of these stresses on system reliability.

Research and case studies in various industries underline the importance of the physical view in ensuring system reliability. For example, in the aerospace industry, continuous stress from vibration, temperature fluctuations, and air pressure variations significantly affects the longevity of components. A study by Aghaei et al. (2022) demonstrated that modeling both physical stresses and their cumulative effects over time was crucial in predicting the failure points of aircraft components, thereby enabling proactive maintenance strategies. Similar approaches are applied in automotive engineering and semiconductor manufacturing, where precise modeling of material fatigue and thermal cycling has significantly improved component design and reliability predictions (Schieber & Hütter, 2020).

The physical view is therefore integral to ensuring that systems are designed with a clear understanding of how cumulative stress impacts component longevity. By integrating both spatial and temporal factors, engineers can predict failure modes and optimize maintenance schedules, ultimately leading to more resilient and reliable systems. The accurate modeling of these stresses helps in preemptively identifying potential failure points, thus mitigating risks and extending the operational life of the system. This holistic approach, which encompasses multiscale interactions, provides a comprehensive understanding of system reliability from a materials perspective. The physical view is not just about understanding immediate responses to operational stress, but about capturing the long-term, cumulative effects of these stresses. The more thoroughly we understand how physical stressors interact with material properties and propagate through a system, the better we can design for durability and reliability, ultimately reducing the likelihood of unexpected failures and improving overall system performance.



### 4.4.2 Characterisation of induced physical phenomena

The elemental components of a system are subjected to a variety of stresses throughout their life cycle. Spot 3, focuses on understanding these stresses in the context of the system architecture, as outlined in Spot 1, and the operational requirements identified in Spot 2. This analysis requires a detailed understanding of the structural hierarchy of the system, recognizing that stresses are induced not only by the operation itself but also by interactions with interconnected elements and the broader environment.

For example, the mechanical stress experienced by a door hinge during operation is directly influenced by its use—how often the door is opened and closed. However, the stress on the hinge also reflects the environmental conditions of the subsystem in which it operates, such as the thermal environment within a vehicle's engine compartment. Characterizing these stresses is critical to defining the operating envelope of the subsystems and informing the design to anticipate and mitigate potential failure modes.

Quantifying stress in terms of extreme or cumulative values characterized by state variables is essential for determining the reliability of the system. It is not enough to simply identify the types of stress—mechanical, thermal, electrical, etc.—but also necessary to measure their magnitude against the resilience capacity of the components. Establishing thresholds for stress thresholds informs that the design process and maintenance schedules, ultimately ensuring the system can withstand its intended use without failure.

### *Challenges in Addressing Vertical Constraint Generation and Exchange*

While Spot 3 research has traditionally focused on the stresses experienced by components due to their functionality and direct interactions, the scientific community has been less engaged in studying the generation and exchange of vertical constraints between different levels of structure. The lack of comprehensive research on the indirect effects of functionally unrelated components, that may nonetheless be involved in a stress transmitting and receiving relationship, points to a gap in the current body of knowledge. This oversight could be addressed through systems engineering approaches that incorporate the combinatorial complexity of these interactions. To advance the study of these complex systems, we must integrate the nuanced perspectives provided by multiscale modelling. As noted by Lytton et al. (2017) and Schieber and Hütter (2020), to understand system failures, one must dissect the system down to its most granular level—examining the stresses on individual components within the context in the system's operation and mission.

## 4.5 Deterministic Framework

In the deterministic framework, we model the behaviour of system components under defined physical stresses, allowing for precise predictions about how these components will perform under various operational conditions. This approach is essential for understanding how physical stresses—such as mechanical loads, thermal effects, or electrical currents—propagate through the system and



influence its reliability. Two key methodologies within this framework are Bond Graphs and System Dynamics, both of which provide powerful tools for representing and analyzing complex systems.

Bond Graphs are a versatile and standardized approach for modeling multi-physical components, whether they be mechanical, electrical, or hydraulic in nature (Rajagopal et al., 2022; Shahidi et al., 2022). This methodology is based on characterizing each component's behaviour through two generalised variables: effort and flow. Effort corresponds to force in mechanical systems, voltage in electrical systems, or pressure in hydraulic systems, while flow represents velocity in mechanical systems, current in electrical systems, or fluid flow rate in hydraulic systems.

The instantaneous power exchange, a central aspect of system dynamics, is expressed as the product of these two variables (effort and flow). By modelling this energy exchange, bond graphs provide a visual and quantitative representation of energy transfer paths, enabling analysts to identify inefficiencies or areas where potential failure might occur within the system (Rajagopal et al., 2022; Shahidi et al., 2022). Through this graphical representation, bond graphs offer a unified approach to analyzing energy interactions across multiple domains, such as mechanical, electrical, and hydraulic systems, making them a critical tool for optimizing system design and ensuring reliability.

### 4.5.1 Bond Graphs: A Standardized Approach to Multi-Physical Components

Bond Graphs are a versatile and powerful tool in the deterministic framework, allowing for the standardised representation of multi-physical components, whether mechanical, electrical, or hydraulic. The core principle of bond graphs lies in the characterization of component behavior through two generalized variables: effort and flow. These variables represent the fundamental interactions within a system:

- Effort corresponds to force in mechanical systems, voltage in electrical systems, or pressure in hydraulic systems.
- Flow represents velocity in mechanical systems, current in electrical systems, and fluid flow rate in hydraulic systems.

The product of effort and flow yields instantaneous power exchange, which is a crucial element in determining the energy transfer and dynamics within the system. By modeling these variables and their interactions, bond graphs provide a comprehensive visual representation of how energy flows through the system, helping to identify areas of inefficiency or potential failure.

For example, in a mechanical system, bond graphs can track how forces propagate through different components, pinpointing where excessive force may accumulate and lead to material fatigue or failure. In an electrical system, they can illustrate how current flows between components as shown in the Figure 16, helping to identify potential bottlenecks or areas where electrical stress might lead to overheating or insulation breakdown. This makes bond graphs particularly useful for multi-physics problems, where mechanical, thermal, and electrical interactions must be modeled simultaneously.

## Physical View

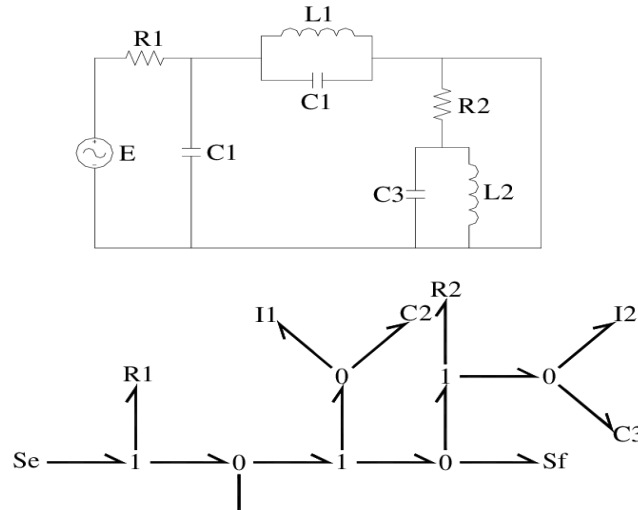

Figure 16. Example of bond graph representing electrical circuit.

The key advantage of using bond graphs is their ability to unify multiple domains (mechanical, electrical, thermal, etc.) into a single framework, allowing for a holistic analysis of how different physical effects influence system behavior. This is crucial in multiscale modelling, where interactions at various scales (from microscopic material properties to macroscopic component behaviors) must be captured to accurately predict system performance.

### 4.5.2 System Dynamics: Modelling Temporal Evolution of Physical Phenomena

In conjunction with bond graphs, system dynamics offers a complementary method for modelling how system behaviors evolve over time. System dynamics focuses on the temporal aspect of component interactions, emphasizing how physical stresses, once applied, change and accumulate within the system over time.

System dynamics is particularly valuable when studying phenomena like fatigue, creep, or thermal cycling, where repeated stresses can gradually degrade material properties. For example, a mechanical component subjected to cyclic loading will exhibit changes in its structural integrity over time. System dynamics allows us to model these time-dependent changes by simulating how the accumulation of stresses—both static and dynamic—affects the overall performance and lifespan of the component.

By combining system dynamics with bond graphs, we can model not only the instantaneous power exchanges within the system but also how these exchanges evolve and lead to long-term effects, such as material fatigue, thermal degradation, or electrical wear. The integration of these methods enables engineers to predict failure modes more accurately and design systems that are robust against both immediate and long-term stresses.

### 4.5.3 Why the Deterministic Framework is Critical

The deterministic framework is crucial for reliability engineering, where the goal is to predict how a system will behave under specific operational conditions and ensure that it performs reliably over its

intended life cycle. By using deterministic models, such as bond graphs and system dynamics, we can:

1. **Predict energy transfer and stress propagation** within the system, identifying where and how physical stresses accumulate.
2. **Quantify the relationship between physical phenomena** (such as force, velocity, and temperature) and component behavior, allowing for precise simulations of component performance.
3. **Simulate the temporal evolution of stresses**, understanding how repeated or prolonged exposure to stresses can lead to fatigue, degradation, or failure.

In engineering applications, deterministic models are indispensable for the design and optimisation of systems. For instance, in aerospace engineering, deterministic modeling allows engineers to predict how airframe components will react to cyclic loads during flight, ensuring that the materials selected can withstand years of repeated use without failure. Similarly, in electronics, deterministic models help predict how electrical currents will affect components over time, identifying potential failure points due to thermal buildup or insulation breakdown.

While deterministic models provide a clear and precise representation of system behavior, they are most effective when used in combination with stochastic models, which account for the inherent uncertainties present in real-world systems. In the next section, we will explore the stochastic framework and how it complements deterministic modelling by addressing variability and uncertainty in system performance.

## 4.6 Stochastic Framework

While the deterministic framework provides a structured and predictable approach to modeling system behavior, real-world systems are often subject to unforeseen uncertainties. The stochastic framework addresses these uncertainties by incorporating probabilistic methods to model variability in system performance. These uncertainties can arise from various factors, such as environmental fluctuations, material inconsistencies, and random operational stresses. In practice, systems rarely operate under perfectly controlled conditions, making it essential to assess how these unpredictable influences affect both system reliability and the likelihood of failures.

The stochastic framework plays a crucial role in providing a more holistic understanding of system behavior, as it moves beyond deterministic predictions by introducing models that account for the probability of occurrence of different failure modes. This allows engineers to not only understand how a system might perform under ideal conditions but also to explore how random events and deviations might lead to unexpected system failures. As a result, the stochastic approach supports more robust design and reliability management, offering strategies for mitigating risks that are inherently unpredictable.

Three key methodologies within this framework are Failure Modes and Effects Analysis (FMEA), Hazard and Operability Study (HAZOP), and the Petri Net method, all of which are designed to anticipate failures by accounting for variability and assessing risk under uncertain conditions.

### 4.6.1 Failure Modes and Effects Analysis (FMEA): Addressing System Failures in Uncertainty

Failure Modes and Effects Analysis (FMEA) is a critical methodology within the stochastic framework due to its ability to anticipate and mitigate unpredictable failures in complex engineering systems. Rather than assuming ideal operating conditions, FMEA embraces the inherent variability and uncertainty present in real-world applications, making it essential for modeling how random stresses can impact system reliability as shown in the Figure 18. In environments where components are exposed to mechanical fatigue, thermal fluctuations, or electrical surges, FMEA helps engineers systematically identify potential failure modes—specific ways in which a component might fail under varying conditions.

The importance of FMEA lies in its structured approach to evaluating the severity, likelihood, and detectability of each potential failure. For example, thermal cycling in high-temperature environments can lead to material fatigue, causing cracks to develop over time. FMEA enables engineers to predict when and where these critical points of failure might occur, allowing them to take preventive actions. These actions may include altering the design geometry to reduce stress concentrations, selecting materials that are more resistant to temperature-induced degradation, or implementing more frequent maintenance to catch potential failures early.

By quantifying risks and prioritizing actions based on their potential impact, FMEA supports the creation of reliable systems that can withstand random operational stresses. Its role in the stochastic framework is essential because it provides a probabilistic assessment of failure, rather than a purely deterministic view, which might overlook the influence of rare but significant stressors. Through this probabilistic lens, FMEA helps engineers optimise resource allocation, ensuring that attention is given to the most critical failure modes, and reduces downtime, improving overall system performance an example is shown in the figure 17.

## Physical View

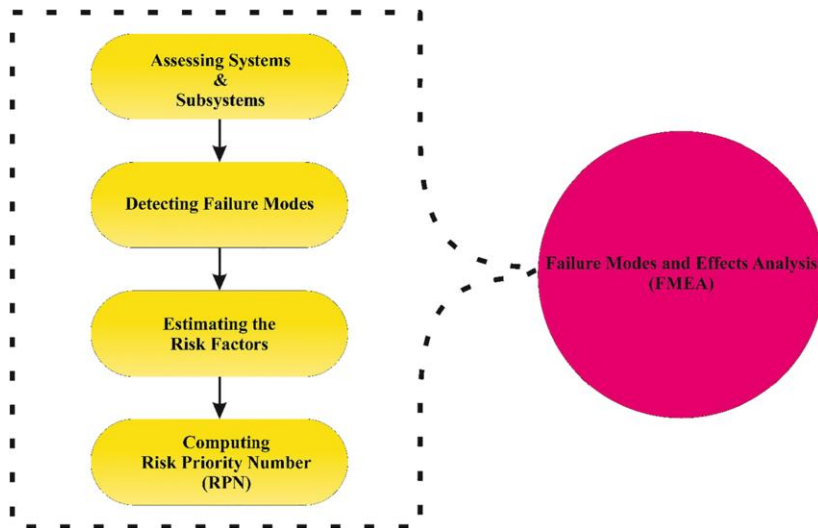

Figure 17. Failure Modes and Effects Analysis (FMEA) Process (cited from(Ardeshirtanha & Sharafati, 2020)

### 4.6.2 Hazard and Operability Study (HAZOP): Ensuring Safety under Uncertainty

Hazard and Operability Study (HAZOP) is another pivotal tool within the stochastic framework, particularly focused on safety-critical systems. While FMEA examines failure modes across components, HAZOP is designed to identify and analyze hazardous deviations from standard operational conditions, especially in industries like chemical processing, nuclear energy, and transportation where failures can have catastrophic consequences. It does so by considering deviations from expected operating parameters, such as abnormal pressures, temperatures, or flow rates, which may lead to dangerous conditions.

The inclusion of HAZOP within the stochastic framework highlights its ability to manage uncertainties that arise from unexpected operating conditions. For example, in a chemical plant, a sudden pressure increase beyond the design limit could cause equipment rupture, leading to both safety risks and operational failure. HAZOP systematically evaluates such deviations and proposes mitigation strategies to prevent them from escalating into larger failures. This method involves interdisciplinary teams who analyze different "what if" scenarios, identifying the root causes of potential hazards and suggesting fail-safe mechanisms or operational changes to address them.

By focusing on deviations that might occur due to random environmental factors or operator errors, HAZOP complements FMEA by addressing operational risks that deterministic models might fail to capture. HAZOP's strength in the stochastic framework comes from its ability to ensure that safety measures are in place to handle rare but high-impact events, contributing to the design of systems that can continue operating safely even under unexpected stresses.

### 4.6.3 Petri Net Method: Modeling Complex Interactions and System Dynamics

The Petri Net method is a powerful tool for modeling systems where concurrent processes and complex interactions between components need to be understood in a probabilistic context. Petri nets offer a graphical and mathematical representation of the dynamic behavior of a system, allowing engineers to model the flow of information, resources, or failures within interconnected subsystems. This method is particularly useful in scenarios where timing, sequencing, and parallelism play crucial roles in determining how systems behave under varying conditions.

Petri nets are highly valuable in the stochastic framework because they enable the simulation of uncertainties within these complex interactions. For example, in a manufacturing process, multiple machines might depend on the same resource. If one machine fails unexpectedly, it can disrupt the entire production line. A Petri net can simulate how this failure propagates through the system, accounting for random failures and resource constraints, and providing insights into bottlenecks or deadlock conditions that might occur here is an example shown in Figure 18.

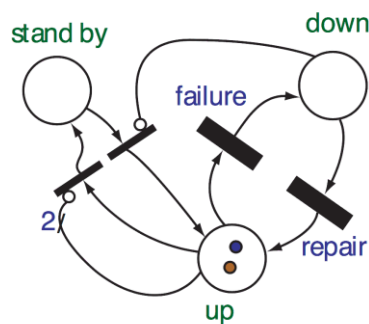

Figure 18. Example of Petri net (Volvoi, 2004)

Moreover, Petri nets allow for both qualitative and quantitative analysis, making them versatile for studying not only the likelihood of failures but also the timing of when these failures might occur. In industries such as automotive, semiconductor manufacturing, and telecommunications, where multiple subsystems operate simultaneously and interact dynamically, Petri nets help engineers identify where resource conflicts or timing issues could lead to system-wide failures.

### 4.6.4 Why the Stochastic Framework is Essential

The stochastic framework plays a crucial role in addressing uncertainties that deterministic models alone cannot capture. In real-world systems, randomness and variability—whether from environmental changes, material imperfections, or operational fluctuations—can significantly influence performance and reliability. By incorporating methodologies such as FMEA, HAZOP, and Petri Nets, the stochastic framework allows engineers to better understand, anticipate, and manage these uncertainties, leading to more robust and resilient systems.

These methodologies enable engineers to identify and prioritize risks by systematically analyzing potential failure modes, hazardous deviations, and the complex interactions between subsystems. For example, FMEA evaluates the likelihood and severity of various failure modes, while HAZOP identifies deviations from normal operations that could result in dangerous conditions. Together, they help pinpoint where failures are most likely to occur, and which areas require the most attention to maintain system reliability.

One of the key advantages of the stochastic framework is its ability to model variability. Unlike deterministic approaches that assume ideal or fixed conditions, stochastic models simulate how random variations—such as changes in environmental conditions, material properties, or operational loads—can impact system performance. This probabilistic approach provides a more accurate representation of real-world scenarios, where systems are often subjected to unpredictable stresses and fluctuations.

By leveraging the insights from FMEA, HAZOP, and Petri Nets, engineers can also develop preventive strategies that enhance system reliability. Whether through design improvements, more robust operational procedures, or contingency planning, these methodologies guide the implementation of risk mitigation techniques that address potential failures before they escalate. For instance, Petri Nets offer a detailed understanding of how small-scale failures in one subsystem can lead to larger, system-wide breakdowns due to interdependencies. This ability to model cascading failures, which are difficult to predict using deterministic models, makes Petri nets invaluable for designing systems that can withstand random operational interactions and failures.

In industries where safety, reliability, and efficiency are paramount, the stochastic framework provides a comprehensive approach to understanding system behavior under uncertain conditions. By modeling these uncertainties, engineers can ensure that systems are better equipped to handle unexpected events and continue functioning reliably across a wide range of scenarios. In essence, the stochastic framework supports the design of systems that are not only functional under ideal conditions but also resilient in the face of the inherent variability found in complex, real-world operations.

### ***From Stress to Reliability Metrics***

The physical stressors—mechanical, electrical, thermal, and so on—that a system endures are quantifiable in terms of energy flows or stress parameters (such as force, temperature, or current). While these flows reflect system activity, they also serve as early indicators of potential wear and failure. The next step involves transforming these physical parameters into reliability indicators, which quantify the likelihood of component failure over time and assist in the decision-making process for maintenance or design improvements (Ebeling, 2010).



To achieve this transformation, specific methodologies are used to link stress data with reliability outcomes:

1. **Data Collection:** Physical parameters such as mechanical force, temperature, or voltage are monitored throughout the component's lifecycle. These data are used to quantify the stress endured by each component. For example, repeated thermal cycles may be measured to understand how temperature fluctuations affect material fatigue (Coffin, 1954; Pecht, 2008).
2. **Stress Analysis:** The collected data is analyzed using methods such as the S-N curve for mechanical stress or Coffin-Manson models for thermal fatigue. These models provide relationships between the applied stress and the number of cycles to failure. By using these models, engineers can estimate how long a component will last under specified stress conditions, directly linking physical parameters to expected failure cycles (Schijve, 2009; Coffin, 1954).
3. **Reliability Model Fitting:** Once the stress analysis is completed, the results are fed into probabilistic models such as the Weibull distribution. These models calculate the probability of failure at various stress levels, helping to account for variability in the system. For example, the Weibull distribution may predict that after 10,000 cycles at a particular stress level, there is a 5% probability of failure. This analysis helps transform raw stress data into reliability metrics such as MTTF, failure rate, or survival probability (Weibull, 1951).
4. **Establishing Reliability Indicators:** Based on the outputs of these models, engineers can establish reliability indicators. These indicators might include:
  - **Mean Time to Failure (MTTF):** An estimate of the average time until failure, derived from the analysis of the component's stress history (Ebeling, 2010).
  - **Failure Rate:** The rate at which components are expected to fail under a given stress.
  - **Probability of Failure:** A probabilistic measure indicating the likelihood that a component will fail after a certain number of cycles or stress exposure (Weibull, 1951).

These reliability indicators are critical for predictive maintenance, helping engineers decide when a component is likely to fail and ensuring timely interventions to avoid unexpected downtime. Furthermore, they allow for the optimization of system design by identifying components most susceptible to failure, guiding material selection, design changes, or enhanced monitoring (Minakuchi et al., 2013; Moran et al., 2003).

### 4.7 (Spot 3'): Identification of failure mechanisms and resulting damage

In analysing the physical behaviour of systems and translating it into terms of reliability and dysfunction, the research landscape is broad and multifaceted. Here is an outline of an analysis area that reflects the complexity and depth of the research needed in this area: The integrity and reliability of systems hinge on a comprehensive understanding of failure mechanisms and the associated damage patterns. This is particularly evident in the complex interplay of physical phenomena and functional



interactions within the various subassemblies of a system. The analysis focuses on two key points in the research landscape.

### ***Spot 3': Identification of Failure Mechanisms***

The academic community has devoted considerable effort to the study of the physical principles underlying the reliability of systems under a range of stresses, from mechanical to electronic and thermal. Historical and classical laws of behaviour, such as Hooke's law for elasticity in mechanics or the Arrhenius equation for thermally induced chemical reactions, serve as the bedrock for these investigations. However, the applicability of these laws is often limited to their initial conditions and does not take into account complex interactions between coupled phenomena.

Research must strive to extend the utility of mechanistic methods, beyond the limitations of classical models. This quest involves broadening the scope of existing models and enhancing their ability to integrate multiple, interacting phenomena. This involves not only refining and iterating upon current models but also developing new models that capture a wider range of conditions and behaviours.

In modelling this physical perspective, it's necessary to identify critical junctures:

- **Initiation of Failure Mechanism:** Determine the time or condition under which a system component begins to fail.
- **Characterization of the Failure:** Defining how the failure manifests in performance or behaviour of the system.

In essence, the physical view in the U-cycle approach emphasizes the importance of identifying and quantifying the physical phenomena and stresses that lead to the component failure as shown in the Figure 19 below. By analysing these factors, we can predict failure mechanisms and take preventive measures to mitigate or prevent system failures. This approach is fundamental to ensuring system reliability and longevity, especially in complex systems where failure can have cascading effects.

### ***Spot 3'- Development of Systemic Approaches***

Alternatively, systemic approaches treat physical phenomena as black boxes, focusing instead on the output responses to varying input parameters. Rather than simplifying, these approaches embrace the complexity of the processes involved. Based on the principles of artificial intelligence and machine learning, these methods require extensive data collection to define the states of variables critical to the genesis of degradation mechanisms. This information-rich approach facilitates both the predictive analysis during the design phase and real-time diagnostic and prognostic capabilities during operation.

The goal here is twofold: to refine the prediction of behaviour based on large amounts quantities of historical data and to use this predictive power in real-time applications. Such models can enhance the design phase with more accurate predictive capabilities and inform maintenance strategies through fault diagnosis. The transition from conceptual physical durability to practical reliability measures is complex and nuanced. Parameters such as allowable stresses, performance thresholds,

and cycle counts must be translated into actionable reliability metrics indicators, such as service life and failure rates. This conversion is far from straightforward, given the need to integrate the time dimension—especially within dynamic, multi-level usage profiles.

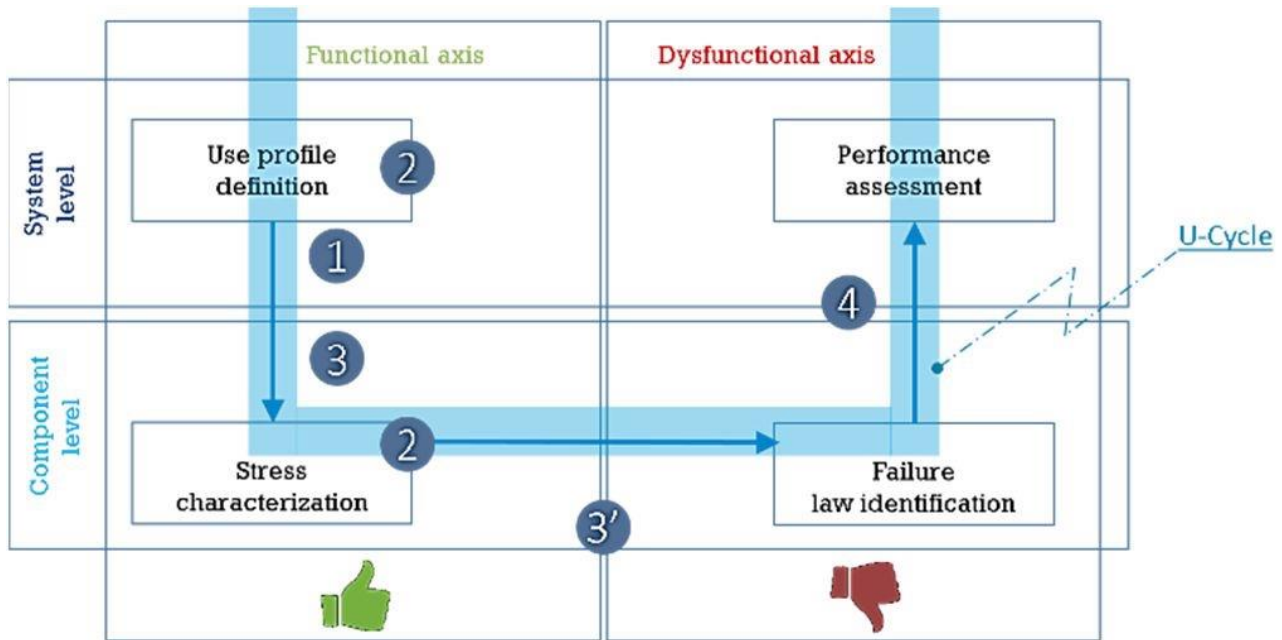

Figure 19. Overlay of Physical view (Spot 3')

It is important to recognize that mechanistic and systemic approaches are not only compatible but complementary. The physical insights gained from mechanistic models can enrich systemic models, which in turn, can provide statistical perspectives that mechanistic models lack. Research should, therefore, pursue these approaches in tandem, allowing each to inform and refine the other. In particular, Monte Carlo methods can bridge the two, using mechanistic knowledge to inform the statistical analysis inherent in systemic approaches. The way forward in research is not singular but a confluence of mechanistic and systemic methodologies. By fostering an interdisciplinary and collaborative research environment, we can better translate the rigorous physical principles into reliable, robust, and resilient system designs.

## 4.8 Conclusion

The primary objective of Chapter 4 was to explore the physical view within the multiscale modeling framework, emphasizing how physical stresses and material properties influence the reliability and performance of complex systems. By focusing on the physical phenomena—such as mechanical stress, thermal effects, and material degradation—the chapter demonstrated how these factors impact system longevity and robustness. This complements the previously discussed structural and temporal views, offering a more complete understanding of system reliability by highlighting the tangible interactions that occur at different scales.

## Physical View

Throughout this chapter, we examined how physical stressors accumulate over time and propagate through systems, transforming these stresses into quantifiable reliability metrics. Key methodologies, including deterministic models like bond graphs and stochastic frameworks using FMEA, HAZOP, and Petri Nets, were applied to predict system behavior under both predictable and uncertain conditions. These models provide critical insights into failure mechanisms, enabling the identification of points where components shift from a functional state to a dysfunctional one. This analysis plays an essential role in system design, maintenance planning, and failure prevention.

The contribution of this chapter lies in its application of multiscale modeling to the physical view, allowing for a more detailed understanding of how material and environmental stresses interact with system components. By transforming physical stress data into reliability indicators, this chapter provides a robust framework for predicting component failure, optimizing system performance, and ensuring long-term reliability.

Looking ahead, Chapter 5 will introduce the logical view, which focuses on the representation of redundancies within the system and measures the impact of these redundancies on overall system performance. This next chapter will build on the physical insights gained here, emphasizing how strategic redundancy can further enhance system resilience and reliability.

## Physical View

# Chapter V

## Logical View

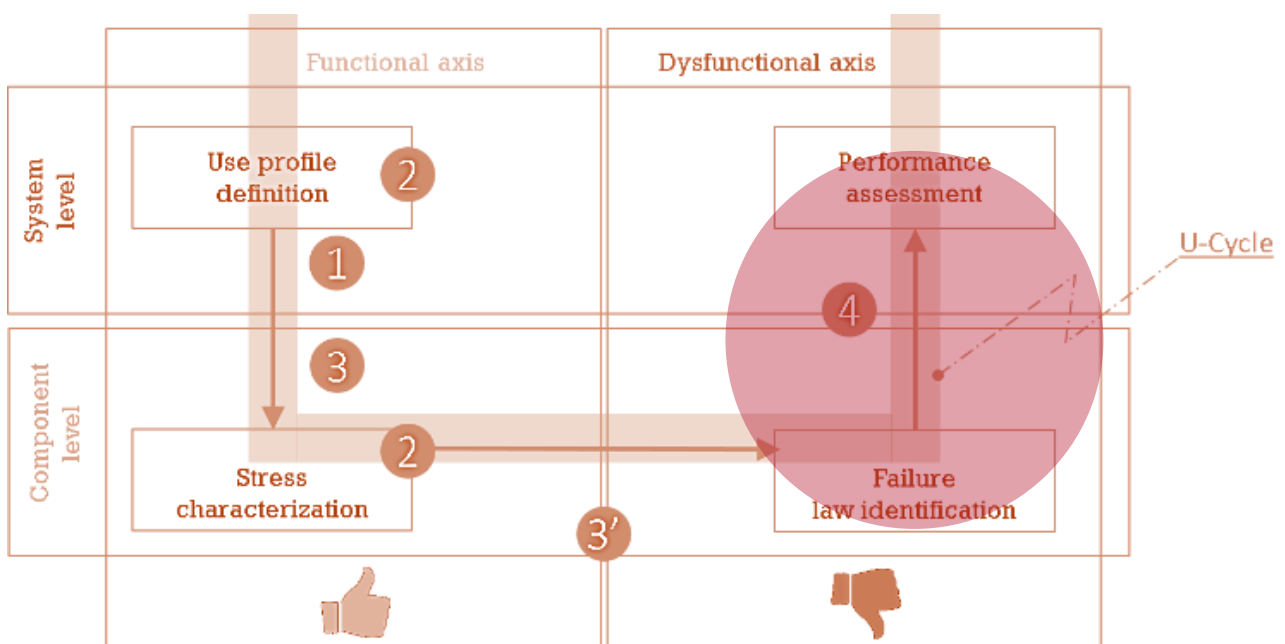

## 5.1 Introduction to Logical view

In the study of complex systems, ensuring reliability and robustness across various operational scenarios is critical. Chapter IV introduced the Physical View, which delves into how physical phenomena—such as mechanical stresses, thermal effects, and material degradation—affect the reliability of system components over time. The Physical View focused on understanding and modeling the material properties and environmental interactions that shape a system's ability to withstand stress, thereby providing insights into component-level vulnerabilities and failure mechanisms.

Building on these insights, Chapter V shifts focus to the Logical View, where the concept of functional redundancy comes to the forefront. While the Physical View emphasized the material and environmental constraints that impact system reliability, the Logical View explores how strategic duplication of critical components within the system architecture can enhance operational resilience. Redundancies act as safeguards, ensuring that even when certain components fail due to physical stresses (discussed in Chapter IV), the system as a whole can continue to function effectively. By integrating both views, we aim to develop a comprehensive approach to system reliability, combining the material and physical interactions outlined in the Physical View with the strategic design mechanisms of the Logical View. Together, these perspectives offer a robust framework for predicting system behavior, minimizing downtime, and enhancing the overall resilience of complex systems.

As modern technological systems become increasingly complex, their reliability has emerged as a critical factor in fields such as aeronautics, energy, automotive engineering, and beyond. These industries demand systems that can perform under extreme conditions while maintaining high levels of reliability. Traditional deterministic models, which rely on fixed assumptions about system behavior, are often inadequate for predicting the performance and failure modes of these complex systems. This inadequacy stems from the fact that real-world systems operate under uncertain conditions, where variations in component performance, environmental factors, and operational stresses introduce unpredictability into system behavior.

To address these uncertainties, probabilistic methods have become increasingly important in reliability engineering. Unlike deterministic models, probabilistic approaches account for the inherent variability in system performance, allowing engineers to assess the likelihood of component failures and system degradation over time. These methods use statistical distributions, failure rates, and life expectancy models to predict how systems will behave under different conditions, enabling more accurate risk assessments and proactive measures to enhance system resilience (Gnedenko et al., 1995; Nachlas, 2017).

In modern complex systems—such as aircraft, power grids, and autonomous vehicles—reliability cannot be ensured by simply designing components to withstand known stresses. Instead, advanced probabilistic techniques are needed to model the range of possible operating conditions and failure

scenarios. These methods help to identify critical failure points, assess the impact of component redundancies, and develop strategies for mitigating risks and ensuring operational continuity (Gnedenko et al., 1995; O’Connor, 2016.). The growing importance of probabilistic methods is evident in the challenges these industries face: systems must not only perform reliably under normal conditions but also remain functional when subjected to unexpected failures, environmental stresses, and operational fluctuations. Functional redundancy—the intentional duplication of critical components or subsystems—has become a key strategy for enhancing reliability in these complex environments, allowing systems to continue operating even when individual components fail (Gnedenko et al., 1995).

This chapter will explore the Logical View of system design, focusing on how functional redundancies are implemented to improve overall system reliability. Building on the Physical View discussed in the previous chapter, which dealt with material properties and environmental stresses, we now turn our attention to the architectural strategies that ensure system robustness in the face of uncertainty. The logical view plays a critical role in system reliability assessment by ensuring functional robustness through redundancy and failure mitigation strategies. Several methodologies have been developed to model this aspect, notably Reliability Block Diagrams (RBDs), Fault Tree Analysis (FTA), and Bayesian Networks. Existing research highlights the importance of functional redundancy in maintaining system performance despite physical failures (Leveson, 2012). RBDs have been widely used in aerospace and automotive safety systems to model the interdependencies between components and assess their impact on overall reliability (Misra, 2020). FTA, on the other hand, enables a top-down approach to failure analysis by identifying the root causes of system breakdowns (Vesely et al., 2002).

However, a key limitation in traditional approaches is their limited integration with real-time monitoring and statistical data analysis. Recent advancements in data-driven reliability assessment suggest that combining historical failure data, probabilistic modelling, and real-time condition monitoring can significantly improve prediction accuracy (Baraldi et al., 2021). This chapter builds on these concepts by proposing a holistic integration of logical and physical views using the U-Cycle approach, reinforcing how data monitoring and statistical analysis enhance functional reliability modelling.

## 5.2 Logical view

The logical view builds on this foundation to specifically address the role of functional redundancies within the system. In this case, redundancy is the strategic duplication of critical components or functions so as to afford the system improved reliability in operation. The system will be able to continue working and prevent total system failure during the time a redundant component fails, thus

ensuring operational continuity (Carzaniga et al., 2009). The purpose of this chapter is to explore how different redundancy configurations can affect overall system behaviour and efficiency.

Key areas to be investigate include:

- Redundancy configurations: Other ways of implementing redundancy of a system, include in parallel or in series (Marseguerra et al., 1999).
- Reliability effects: Redundancy increases the reliability of the system by providing alternative paths for functionality in the event of failure of some of the parts occurs.
- Operational behaviour: The effect of any redundancy on the operational behaviour of a system's, on the performance measures, and on the response to failures (Morris, 2023).

The analysis is primarily supported using reliability block diagrams. Such diagrams depict the system architecture, i.e., the interdependencies among the system elements and how the introduction of redundant elements materializes. An example is shown in Figure 20 which clearly illustrates the introduction of redundant structures within the system architecture clearly materializes. The logical architecture associated with the introduction of parallelism is shown. Robustness with respect to parallelism reflects the ability of the system to maintain its operation even in the event of the failure of one or more elements to reduce downtime.

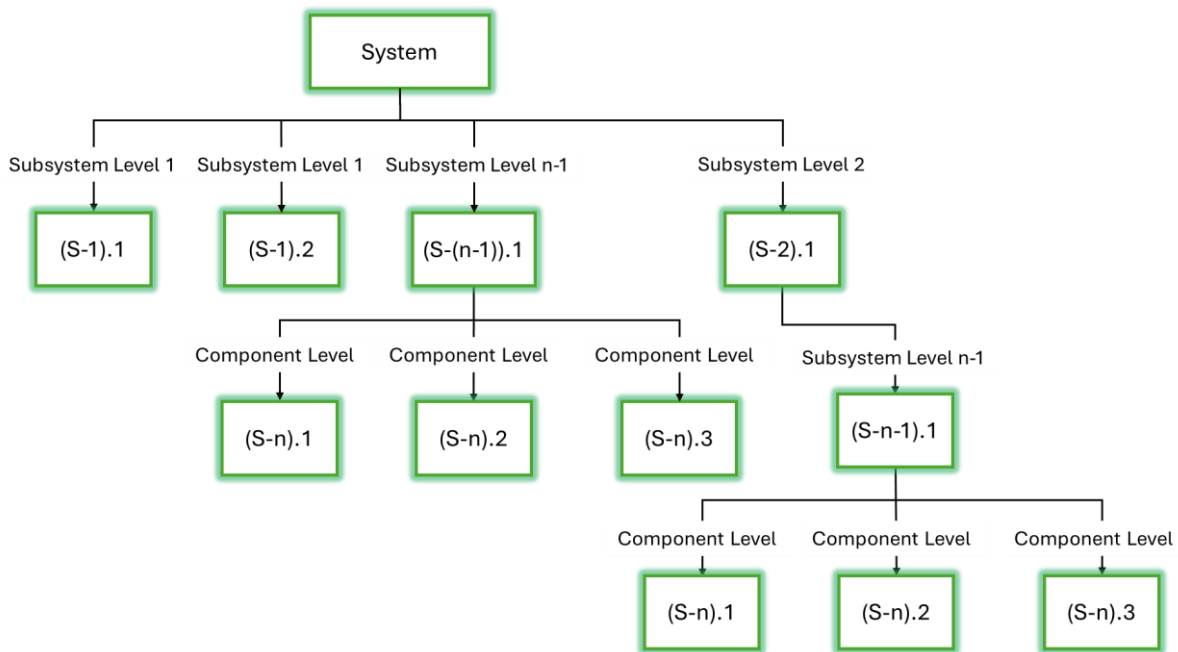

Figure 20. Example of a reliability block diagram of a redundant architecture

Most of the academic research work has been carried out on these topics, i.e., characterization of failure rates and system reliability under different situations. Their research has also proposed methodologies for predicting the behaviour of a system over time considering different standpoints and focusing on various modelling aspects associated with:



- Failure laws: to describe the behaviour of component failures with respect to probabilistic models for example, Gamma, Wiener, Poisson processes.
- Maintenance quality: to determine the state of maintenance activities on the system from perfect to imperfect in relation to the reliability of the system.
- Degradation type: to assess the system performance derived from discrete, progressive, continuous types of degradation.
- Component analysis: to study the influence of mono or multi-component systems with their specific reliability issues.
- Time horizons: to evaluate the impact of the finite or infinite period, with respect to reliability parameters (European Power Supply Manufacturers Association, 2005).

These dimensions are further analysed to improve the logical view of system reliability. The chapter summarizes the methodologies used and to be used in quantifying the impact of component failures and the consequences of redundancy and parallelism in the system, and reviews some of the key literature findings to forge new research ideas and implications in general for system reliability and operational safety.

The study of how functional redundancies are represented and affect system performance will contribute to system robustness with respect to component failure. This chapter will explore the dynamics involved, looking at how different redundancy configurations can affect the behaviour and efficiency of the system as a whole and, in turn, provide critical insight into how to design more resilient systems. This section only provides an overview of the abundant literature that has developed in the academic world on this subject. The goal of the researchers is to evaluate the reliability of systems in terms of their basic component failure rates and to predict system behaviour over time. The approaches used in this field are diverse and reflect different assumptions about the failure law, the quality of maintenance, the nature of degradation, the multiplicity of components, and the time horizons under consideration.

### 5.3 Aim of the Work

The primary objective of this chapter is to analyze overall system reliability by investigating the effects of component failures and their interactions at the system level. This analysis moves beyond individual component reliability to examine how system-wide reliability can be optimized through the integration of functional redundancies and advanced probabilistic methods. As modern systems grow more complex and interconnected, especially in safety-critical fields such as aerospace, energy, and automotive engineering, ensuring system-level reliability has become increasingly important. This chapter addresses the challenge of maintaining system functionality despite component failures by incorporating probabilistic reliability models and redundancy mechanisms at both the component and system levels.

#### *Exploring Advanced Probabilistic Methods at the System Level*

Probabilistic methods provide a robust framework for evaluating the uncertainties that arise not just from individual component failures, but from their propagation across an entire system. Unlike deterministic models that offer fixed predictions, probabilistic approaches allow for a comprehensive view of the variability in system behavior, incorporating factors like operational conditions, environmental stresses, and the inherent variability of materials. The focus here is on understanding how the combined effects of component failures and their interdependencies influence overall system reliability.

This chapter will explore several probabilistic models, such as the Weibull distribution, exponential distribution, and normal distribution, to model component reliability. However, the key objective will be to assess how these models extend to the system level, where the interaction between multiple components plays a pivotal role in determining the likelihood and impact of system-wide failures. By quantifying the failure probabilities of components and analyzing how these propagate through the system, engineers can gain insights into potential vulnerabilities and optimize system reliability accordingly.

### ***The Role of Functional Redundancies in System-Level Reliability***

One of the key strategies examined in this chapter is the implementation of functional redundancies to improve system-level resilience. Functional redundancy refers to the duplication of critical components or subsystems, ensuring that a failure in one component does not lead to total system failure. While redundancies at the component level are well-understood, this chapter will investigate how redundancy configurations—such as series, parallel, or hybrid—impact the reliability of the entire system, especially in terms of how failures propagate through these redundant structures.

By adopting a system-level perspective, this analysis will emphasize how redundancies can mitigate the impact of component failures, preventing them from cascading into larger system-wide dysfunctions. For instance, parallel redundancy allows multiple components to perform the same function, thus maintaining system operation even if some components fail. The exploration will focus on how various redundancy schemes can be optimized to reduce overall failure probabilities and extend system lifespans in critical applications.

### ***Enhancing System Resilience and Understanding Failure Propagation***

A major focus of this chapter will be on modeling not just individual component failures, but the way these failures interact within the system. As we shift from a functional to a dysfunctional view, it becomes essential to understand how component failures propagate through interconnected systems and impact overall system behavior. This chapter will examine how advanced probabilistic models can be used to predict and mitigate the cascading effects of failures, ensuring that systems remain resilient even in the presence of multiple component failures.

By analyzing the probabilistic nature of component failures within redundant system architectures, the study will demonstrate how redundancy, failure propagation, and system interactions can be optimized to increase overall reliability. This includes calculating the failure probabilities for individual components and understanding how these contribute to the system's failure modes and overall reliability.

### *System-Level Design Optimization and Reliability Strategies*

The insights from this investigation will inform strategies for optimizing system-level reliability. By understanding how component interactions and redundancies affect system behavior, engineers can make data-driven decisions about where to introduce redundancies and how to structure systems for maximum reliability. Furthermore, this section will underscore the importance of system-level reliability analysis for identifying weak points and failure dependencies, allowing for more targeted maintenance and resource allocation.

This analysis will be particularly useful for developing preventive strategies in safety-critical systems, ensuring that system-level designs are not only robust but also capable of continuing operation under adverse conditions. By leveraging probabilistic models, engineers can optimize system architectures to improve both performance and safety.

### *Focus on Safety-Critical Applications*

The consequences of system failure in safety-critical applications—such as aircraft systems, power plants, and autonomous vehicles—are often catastrophic. Therefore, the ability to tolerate component failures while maintaining overall system functionality is paramount. This chapter will apply the insights gained from probabilistic reliability modeling and redundancy analysis to ensure that such systems can continue to operate safely and efficiently, even in the face of component dysfunctions.

By demonstrating how system-level reliability can be enhanced through functional redundancies and probabilistic modeling, the chapter will offer practical recommendations for designing and maintaining resilient systems in safety-critical environments. These findings will contribute to the development of more robust, longer-lasting systems where failure is not an option.

## **5.4 Reliability Block Diagram (RBD) for System Reliability**

### 5.4.1 Introduction to Reliability Block Diagrams (RBD)

In addressing the challenge of system-level reliability, Reliability Block Diagrams (RBDs) provide a valuable tool for visually representing and analyzing the relationships between components in a system. RBDs illustrate how different components work together to ensure the system functions, and importantly, how these components contribute to overall system reliability. This method is particularly effective in demonstrating the impact of redundancy configurations—such as series,

parallel, or hybrid structures—on system performance and resilience (Gissler & Shrivastava, 2015; Iudean et al., 2018).

In this section, we will explore the role of RBDs in optimizing system reliability by evaluating the effect of component failures on the entire system shown in the figure 21. By modeling various redundancy strategies, we aim to show how system reliability can be enhanced, particularly when applying advanced probabilistic methods to assess component behavior. A typical example of reliability block diagram models reliability by showing which subsystems can fail without causing overall system failure and which ones must work for system success (Distefano & Liudong Xing, 2006; Xu et al., 2009)

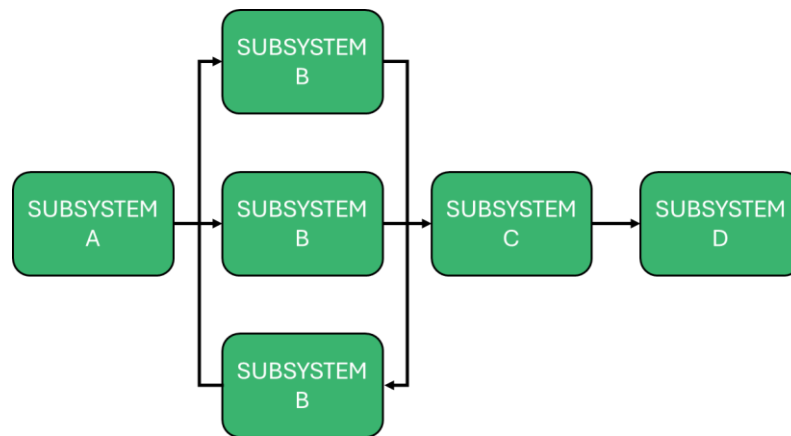

Figure 21. Reliability block diagram

### 5.4.1.1 Why Use RBD in System Reliability Analysis?

In complex systems, understanding how individual components affect overall system performance is critical. The RBD approach logically breaks down the system into blocks, each representing a component or subsystem. The relationships between these blocks—whether arranged in series, parallel, or a hybrid configuration—are mapped to analyze how failures in one or more components impact the whole system. This logical decomposition serves several purposes:

- **Visualization of system architecture:** RBD offers a clear graphical representation of the system, making it easier to identify potential failure points and redundancy opportunities (Catelani et al., 2015, 2019).
- **Quantification of reliability:** By assigning reliability values to individual components and calculating the system's overall reliability, RBD enables engineers to model failure probabilities and assess risk (Cota & O'Halloran, 2016).
- **Optimization of design:** RBD helps optimize system architecture by showing how different redundancy strategies (e.g., adding parallel paths) can enhance system resilience without excessive costs (Catelani et al., 2014).

For example, in industries such as aerospace, energy, and automotive, RBDs are essential for ensuring mission-critical systems can withstand failures and maintain functionality. These systems require high levels of reliability, and RBD offers a logical framework to predict when and where failures might occur (Ping et al., 2023).

### 5.4.1.2 The Logical Framework for Series, Parallel, and Hybrid Configurations

Our research focuses on advancing methods for evaluating and enhancing the reliability of complex systems. By systematically identifying and analysing the performance of individual components and subsystems, we aim to provide comprehensive solutions that strengthen the overall robustness and reliability of these systems. Our approach integrates meticulous reliability data collection and analysis at the elementary component level, which we then aggregate to create detailed reliability profiles for each subsystem. This hierarchical approach ensures that the reliability characteristics of each element are thoroughly understood and optimized, contributing to the greater reliability and performance of the entire system. Our research not only elucidates the intricate relationships between components and subsystems but also provides structured methodologies for evaluating and improving system reliability, thus ensuring that each subsystem functions optimally within the larger system architecture. In reliability engineering, the first step in evaluating the performance of a system is to identify and understand its components and subsystems. This process lays the foundation for a comprehensive reliability analysis by mapping out the structure and interconnections within the system. Here we detail the methodology for identifying these components and subsystems and explain how their configurations affect the overall system reliability.

- **System decomposition:** System decomposition involves breaking down a complex system into smaller, more manageable parts. Each part, or subsystem, consists of individual components whose reliability can be assessed independently. The goal is to create a hierarchical representation of the system that reflects its functional architecture.
- **Elementary components:** These are the most basic units in the system, often referred to as "parts" or "elements." Examples include resistors, capacitors, transistors in electronic systems, or bearings, gears, and shafts in mechanical systems. Each component has specific reliability characteristics, such as failure rates, mean time to failure (MTTF), or mean time between failures (MTBF).

**Subsystems:** These are intermediate aggregations of elementary components that work together to perform a specific function within the larger system. Subsystems can often be categorized into functional groups, such as power supply, control modules, or processing units.

## Logical View

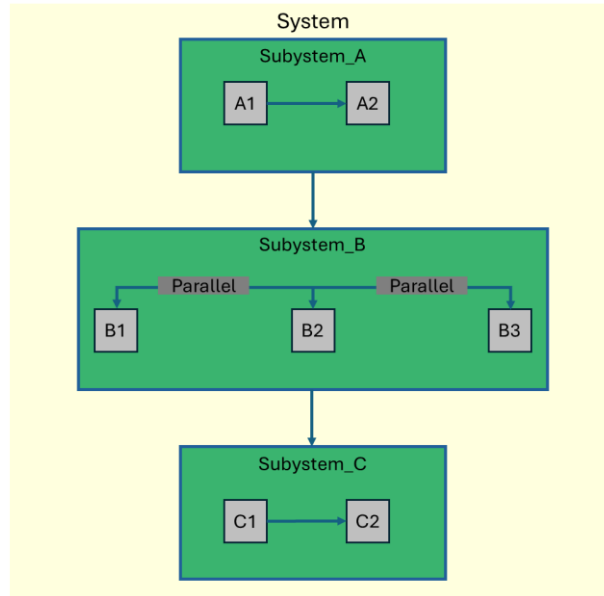

Figure 22. System Subsystems Configuration Diagram

### 5.4.2 Series Configuration: Understanding Vulnerability and Improving Resilience

#### 5.4.2.1 Challenges in Series Configuration

In a series configuration, the system operates only if all components function correctly. The system fails if any one component fails, making it highly vulnerable to even a single point of failure. This is a significant challenge, especially for complex systems where multiple interdependent components are involved. The overall system reliability  $R_{\text{system}}$  series configuration is calculated as:

$$R_{\text{system}} = R_1 \times R_2 \times \dots \times R_n \quad (1)$$



Figure 23. Series configuration

As shown, even with highly reliable components, the reliability of the overall system decreases with each additional component. This compounding of failure risks highlights a critical area where improving system resilience requires targeted solutions.

#### ***Innovative Solutions and Research Approach***

Our research acknowledges the inherent vulnerability of series systems and aims to develop innovative approaches that reduce this risk. We focus on functional redundancies and predictive failure diagnostics to address this issue.

### ***1. Dynamic Failure Detection and Functional Redundancy Allocation***

Building on the logical view of failure mechanisms, we incorporate a system that dynamically detects potential failures using real-time data from system components. This is achieved through advanced probabilistic modelling that predicts the likelihood of failure based on historical performance data, environmental factors, and stress levels. Once a high-risk component is identified, functional redundancies are immediately allocated to that component, allowing the system to maintain operation. This method ensures that the system adapts to evolving failure risks, reducing the likelihood of complete system failure.

### ***2. Redundancy-Enhanced Subsystem Structures***

For critical subsystems arranged in series, we propose introducing localized redundancies that target specific failure-prone components without overcomplicating the entire system. By applying a partial parallel redundancy only to the most critical series components (e.g., in power distribution or control systems), we enhance system reliability while maintaining operational efficiency. This approach avoids the inefficiency of full-system redundancy but mitigates the vulnerabilities inherent in series configurations (Harper & Pal, 2024; S. Li et al., 2024; X. Li et al., 2024).

#### 5.4.3 Parallel Configuration: Leveraging Redundancy for Higher Reliability

##### **Advantages and Challenges in Parallel Configuration**

In a parallel configuration, the system continues to function as long as at least one component remains operational. This design inherently improves reliability since redundant components can take over in case of failure. The reliability for a parallel system is calculated as:

$$R_{system} = 1 - ((1 - R_1) \times (1 - R_2) \times \dots \times (1 - R_n)) \quad (2)$$

The logical strength of parallel configurations is that they significantly enhance system resilience by introducing redundancy. However, this comes with challenges, such as resource consumption, increased system complexity, and higher maintenance costs due to the additional components.

The diagram illustrates a parallel configuration for reliability, where multiple components (Component 1, Component 2, and Component 3) are connected in such a way that the failure of one component does not lead to the failure of the entire system. In this setup, the system will continue to function as long as at least one component remains operational. The "Success" in the diagram indicates that the system can still achieve its intended purpose even if some components fail, thanks to the redundancy provided by the parallel configuration. This makes the system more reliable, as it doesn't depend on a single component for success but rather on the availability of any one of the components in the configuration (Di et al., 2014; Marian, 2017).

## Logical View

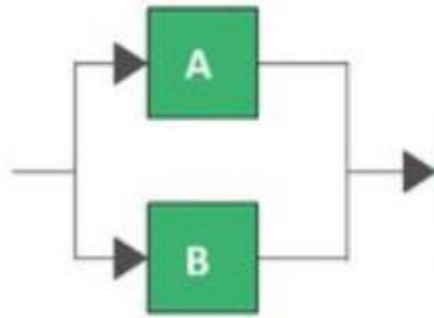

Figure 24. Parallel configuration for reliability

### 5.4.3.1 Innovative Solutions and Research Approach

Our research focuses on optimizing the use of parallel configurations while minimizing their downsides. We achieve this through intelligent redundancy management and multi-layer functional integration, which reduce resource consumption without compromising reliability.

#### 1. *Intelligent Redundancy Switching*

Rather than keeping all redundant components active at all times (as is typical in parallel configurations), we introduce intelligent switching mechanisms. Redundant components remain in a low-power or standby mode and are only activated upon detecting a potential failure in the primary component. This dynamic redundancy management minimizes energy consumption and extends the lifespan of system components, thereby lowering operational costs (Sadeghi et al., 2021; Yu et al., 2023).

#### 2. *Functional Layering and Redundancy Prioritization*

Drawing on the logical relationships between system layers—as discussed in our work—we propose a multi-layer redundancy model. Instead of treating all components equally, we categorize them based on functional criticality. High-priority components (such as safety controls in aerospace systems) are provided with multiple layers of redundancy, while less critical functions receive basic redundancy. This approach ensures that critical functions maintain a high level of reliability, while overall system complexity and cost are optimized (Mousavi et al., 2019; M. Wang & Mesbahi, 2024; Y.-C. Wang & Cinar, 2024).

### 5.4.4 Reliability Block Diagram (RBD) of Hybrid Configuration

Hybrid configurations are used in system reliability analysis to address complex systems that cannot be accurately represented by simple series or parallel arrangements. A hybrid configuration combines elements of both series and parallel structures, but its complexity arises from conditional dependencies and multiple operational paths. In such systems, reliability is not simply a function of



component redundancy; rather, it depends on how components interact and respond to partial failures or changing conditions.

This chapter focuses on the role of hybrid configurations in enhancing system reliability by:

- Allowing for selective redundancy in critical subsystems while conserving resources in non-critical areas.
- Enabling graceful degradation of system performance, meaning that partial failures do not lead to total system breakdown.
- Incorporating conditional operational paths, where the failure of certain components leads to alternate pathways, ensuring system functionality.

In the following sections, we will explore how hybrid configurations differ from traditional RBDs and discuss the limitations of diagrammatic approaches in representing certain complex systems. Additionally, we will demonstrate how probabilistic methods and formula-based approaches are necessary to calculate the reliability of these configurations accurately.

### 5.4.4.1 Explanation of Hybrid Configurations with Conditional Dependencies

In complex systems, hybrid configurations extend beyond traditional series or parallel arrangements by incorporating components that introduce conditional dependencies. These configurations adapt to different operational scenarios, allowing the system to maintain functionality even when critical components fail. This flexibility is achieved through dynamic operational paths and the interaction between components, which ensures that partial system performance can still be achieved under certain failure conditions.

For example, in complex systems where hybrid configurations are used, reliability analysis can often be simplified by breaking down the system's operation into mutually exclusive events. This approach is well-suited when dealing with systems that have conditional dependencies between components, like the system depicted in the example of **M3**.

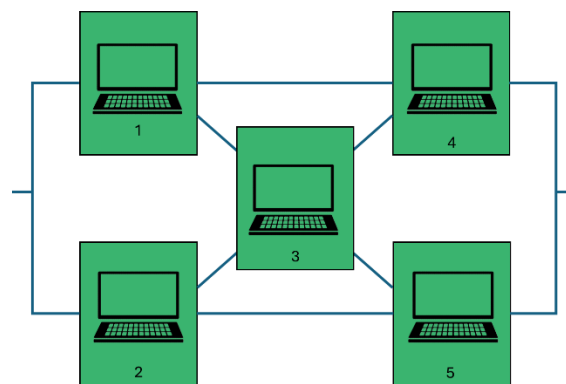

Figure 25. Hybrid System Configuration with Critical Component M3

**Breakdown Using the Total Probability Theorem:**

The system presented in the diagram relies on **M3**, a critical component that introduces complexity. By applying the **total probability theorem**, we can analyze the system by considering two possible states of **M3**:

1. M3 is operational
2. M3 has failed

**1. Case 1 : M3 is Operational (R)<sub>3</sub>**

When **M3** is operational, the system can still rely on the remaining components to maintain its functionality through multiple paths. In this case, we can simplify the system's reliability by analyzing how the other components work in conjunction with **M3**.

- Path 1-4-5: One path through the system starts from Component 1, goes through Component 4, and finally reaches Component 5. The reliability of this path can be expressed as the product of the reliabilities of each component involved in the path. Since this is a series path, the overall reliability is dependent on all three components being operational.
- Path 2-5: Another potential path starts from Component 2 and goes directly to Component 5. This path offers an alternative route for the system to remain functional, and its reliability is likewise a product of the individual reliabilities of Component 2 and Component 5.

Reliability diagram if M3 operational?

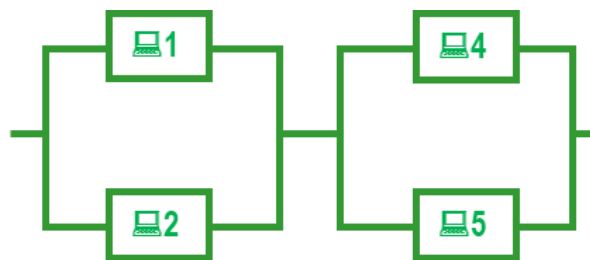

Thus, the total reliability of the system when **M3** is operational is a combination of these parallel paths.

**2. Case 2: M3 Has Failed (1-R)<sub>3</sub>**

If M3 fails, the system must rely solely on the components that bypass M3 to maintain functionality. The total reliability in this case depends on whether these alternative paths can still ensure system operation. Specifically, we must consider the paths as shown in the Figure 26:

## Logical View

case with  $M_3$  operational  
+ case with  $M_3$  faulty

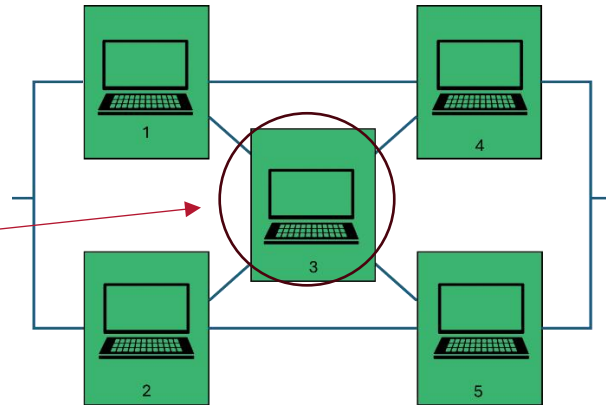
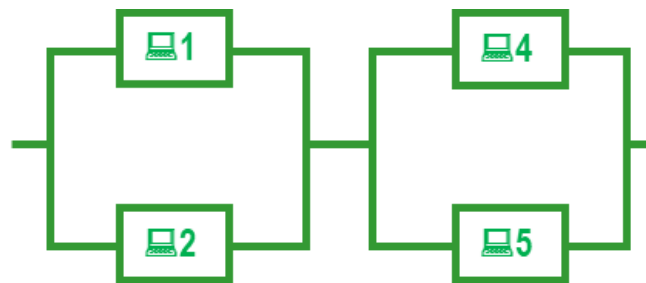

Figure 26. Case with  $M_3$  is Faulty

**Path 1-4-5:** Just as in the previous case, this path provides a potential route to system reliability. However, the system's overall reliability is now reduced because  $M_3$  is no longer operational, meaning the system must rely more heavily on this alternative path.

**Path 2-5:** This direct path from Component 2 to Component 5 is still available, but as before, the failure of any component along the path will result in system failure.

### Reliability diagram if $M_3$ ?



Using the total probability theorem, we combine the reliability for both cases to derive the overall system reliability ( $R_t$ ). This is calculated as:

$$R_t = R_3 \times (\text{reliability when } M_3 \text{ is operational}) + (1 - R_3) \times (\text{reliability when } M_3 \text{ fails}) \quad (3)$$

The application of the total probability theorem provides an effective approach to analyzing the reliability of complex systems, particularly those with conditional dependencies, such as hybrid configurations. By breaking the system down into two mutually exclusive cases—when  $M_3$  is operational and when  $M_3$  fails—we can accurately capture the system's overall reliability. The first term of the formula accounts for the reliability when  $M_3$  functions, with multiple parallel and series paths ensuring the system's success. The second term addresses the scenario where  $M_3$  is faulty, emphasizing the importance of alternative pathways. By summing both cases, this formula

encapsulates the complete range of operational conditions, offering a comprehensive and precise reliability assessment for systems that cannot be adequately represented by simple block diagrams alone.

$$R_t = \{R_3 [1 - (1 - R_1)(1 - R_2)] [1 - (1 - R_4)(1 - R_5)]\} + \{(1 - R_3) [1 - (1 - R_{14})(1 - R_{25})]\} \quad (4)$$

In this way, the complex system is simplified into two conditional scenarios, each of which can be analyzed individually. By considering both the operational and failure cases of **M3**, we can accurately model the overall system reliability, incorporating the effects of redundancy and component interactions. This approach highlights how hybrid configurations can be analyzed effectively despite their complexity.

#### 5.4.4.2 Challenges in Representing Complex Systems with Diagrams

In complex systems, traditional Reliability Block Diagrams (RBDs) often fall short in representing reliability accurately. RBDs work well for simple series or parallel configurations, but they struggle to capture more intricate setups where a specific number of components must function for the system to remain operational. These systems often exhibit conditional redundancy, where only a subset of the components needs to work for the system to succeed.

A classic example of this is a system where two out of three identical components are required for the system to function. While this cannot be easily modeled with a block diagram, it is a common reliability scenario, particularly in systems where full redundancy is unnecessary, and the system can tolerate partial failures.

#### Limitations of RBDs for Conditional Redundancy

In such systems, the interactions between components are not linear, and their operational states are dependent on one another. For example, in a simple series configuration, the failure of one component leads to total system failure, while in a parallel configuration, all components must function independently to provide redundancy. However, in systems where 2 out of 3 components need to be operational, these simple series or parallel arrangements do not accurately represent the system's reliability.

In cases like this, a diagram cannot fully illustrate the various possible operational states. Instead, probabilistic methods must be used to calculate reliability. The system's reliability is determined by the number of operational components and how failures in individual components affect the system's overall performance.

#### Formula-Based Approach: Binomial Distribution

To calculate the reliability of systems with conditional redundancy, we apply the binomial distribution formula. This formula allows us to model the probability that at least a certain number of components will function correctly out of a total number of components.

For example, if two out of three components must function for the system to succeed, the reliability of the system  $R_t$  can be calculated using the following formula:

$$R_i = \sum_{j=k}^n C(n, j) R^j (1 - R)^{n-j} \quad (5)$$

Where:

- $n$  is the total number of components (in this case, 3),
- $k$  is the minimum number of components required to function (2),
- $R$  is the reliability of each individual component,
- $C(n, j)$  is the binomial coefficient, representing the number of ways  $j$  components can function out of  $n$ .

This formula accounts for all possible combinations of operational and failed components, enabling us to calculate the probability that at least 2 components will function, even if 1 fails. Such probabilistic calculations ensure that the system's partial functionality is accurately modeled.

### 5.4.4.3 Application to Our System

In the system analyzed in this research, a similar situation arises, where a subset of subsystems must be operational for the overall system to maintain functionality. For example, in cases where three critical components are installed, only two need to function to prevent system failure. This conditional dependency cannot be captured with a traditional RBD because it is neither purely series nor parallel. The interaction between components and the redundancy level required introduces complexity that needs a formula-based approach.

By applying the binomial distribution formula, we can accurately calculate the reliability of our system under varying failure conditions. This allows us to account for the possibility that while some components may fail, the system can still operate with the remaining functional components. The use of this probabilistic method ensures that we can design the system to meet reliability targets without over-engineering redundant components. In summary, while traditional RBDs are useful for representing simple systems, they fail to capture the complexity of systems where conditional redundancy is present. For systems like those analyzed in this research, where a specific number of subsystems must function for operational success, formula-based methods, such as the binomial distribution, provide a more accurate way to calculate reliability. This approach allows us to optimize the design by ensuring sufficient reliability without unnecessary redundancy, maintaining both cost-efficiency and system robustness.

### 5.5.5 Key Concepts and Mechanisms Behind Failure-to-Working Switches

#### **Redundant Systems and Failover Switches**

In complex systems, particularly those using parallel redundancy (as seen in hybrid or fully redundant configurations), a switching mechanism is necessary to handle component failures. When a primary component fails, the system detects the failure and switches to a backup component without interrupting operations. For instance, in power supply systems, if the primary power source fails, a redundant backup generator takes over via a failover switch, ensuring seamless operation. This is

essential in applications such as data centers, hospitals, and aerospace systems, where downtime is unacceptable.

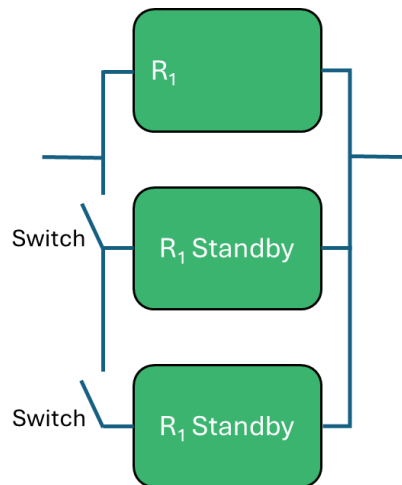

Figure 27. Redundant System with Standby Components for Failure-to-Working Switching

### Automatic Fault Detection and Recovery (AFDR)

The switch is often part of an Automatic Fault Detection and Recovery (AFDR) system, which monitors system components in real time. Upon detecting a fault, the AFDR triggers the switch to engage a backup component. In modern systems, this process is highly automated, using intelligent monitoring systems with sensors and controllers that detect abnormalities (such as increased heat, vibrations, or signal degradation), signaling a switch before complete failure occurs.

### Hot Standby vs. Cold Standby

- Hot Standby: The backup component runs in parallel with the primary component, ready to take over immediately upon failure, allowing for near-instantaneous switching.
- Cold Standby: The backup component remains inactive until a failure is detected, at which point the switch activates the backup component. Cold standby conserves resources but introduces a slight delay during the switch.

### Switching Logic and Control

Switch logic determines when and how to activate the backup component. Decision algorithms play a critical role, using either time-based failure prediction (monitoring component wear and signaling before failure) or event-based triggering (activating upon failure). Some systems use partial system failure analysis, allowing the switch to engage only specific subsystems or components, rather than initiating a full-system switchover.

### Multi-Component Systems and Hybrid Redundancy

In hybrid configurations that combine series and parallel components, a switching mechanism ensures that when critical parallel components fail, the backup components take over immediately. This may include cross-component switching, where if a critical component in one subsystem fails, another subsystem compensates for the failure to maintain functionality.

### **Dynamic Fault-Tolerant Switching in Hybrid Systems**

In hybrid configuration, where both series and parallel components are combined, a dynamic switching mechanism would ensure that critical parallel components (e.g., backup systems) seamlessly take over if primary components in a series configuration fail. For example, in a power management system with parallel redundant generators, if the primary generator fails, the system uses a fault detection algorithm to immediately switch to a backup generator, preventing a system-wide failure. The switch happens in real time, triggered by sensors monitoring voltage drops or other failure indicators.

### **Failure Mode Analysis and Real-Time Reconfiguration**

As part of our research, the switch could be triggered not only by outright failure but also by signs of imminent failure detected through real-time monitoring. This links to predictive maintenance and diagnostic tools you are exploring, where failure detection occurs before a full component breakdown. When the system detects that a component is moving toward failure (e.g., showing abnormal heat or mechanical wear), it can preemptively switch to the backup component. This is especially valuable in hybrid configurations where critical paths must avoid any downtime.

### **Innovative Switching Mechanism Based on System Behavior**

Our research could innovate through adaptive switching based on component criticality and system behavior. By dynamically prioritizing components (based on failure rates or environmental stress), the system can determine whether the switch should occur immediately or whether degraded performance can be tolerated temporarily until maintenance is performed.

### **Multi-Stage Switching**

For complex systems, multi-stage switching may be employed, where the system switches not only to a single backup but cycles through multiple backup options. For example, if the primary power source fails, the system may first switch to generator A, but if generator A shows signs of degradation, it can switch to generator B in a cascade. This layered approach ensures continuous operation despite multiple component failures.

## 5.5 Fault tree analysis in system reliability

### 5.5.1 What is Fault Tree Analysis (FTA)

Fault Tree Analysis (FTA) is a widely used method in system reliability engineering to analyze the causes of system failures. It is a top-down, deductive failure analysis tool that visually represents the logical relationships between component failures and system-level failures. By breaking down a system's possible failure modes into their underlying causes, FTA helps engineers understand how individual component failures can propagate to impact overall system reliability. This method is particularly useful in safety-critical and mission-critical applications, where understanding the root causes of failures is essential for designing robust and reliable systems.

**Fault Tree Analysis (FTA)** is a structured, graphical methodology used to illustrate in the figure 28 below explains the relationships between potential causes of system failures. The analysis starts with a top-level event (TLE), typically a system failure, and traces backward through a series of logical gates (e.g., AND, OR) to identify the root causes contributing to that failure.

#### Key Elements of FTA:

- **Top-Level Event (TLE):** This represents the primary system failure or undesired event that the analysis seeks to mitigate.
- **Basic Events:** These are individual component failures or faults that contribute to the top-level event.
- **Logical Gates:** These gates connect the basic events and define how the failures combine to trigger the top-level failure. Common gates include:
  - **AND Gate:** All connected component failures must occur simultaneously for the top-level event to take place.
  - **OR Gate:** The top-level event occurs if any one of the connected basic events occurs.
- **Intermediate Events:** These represent higher-level failure modes resulting from the combination of multiple lower-level events.



## Logical View

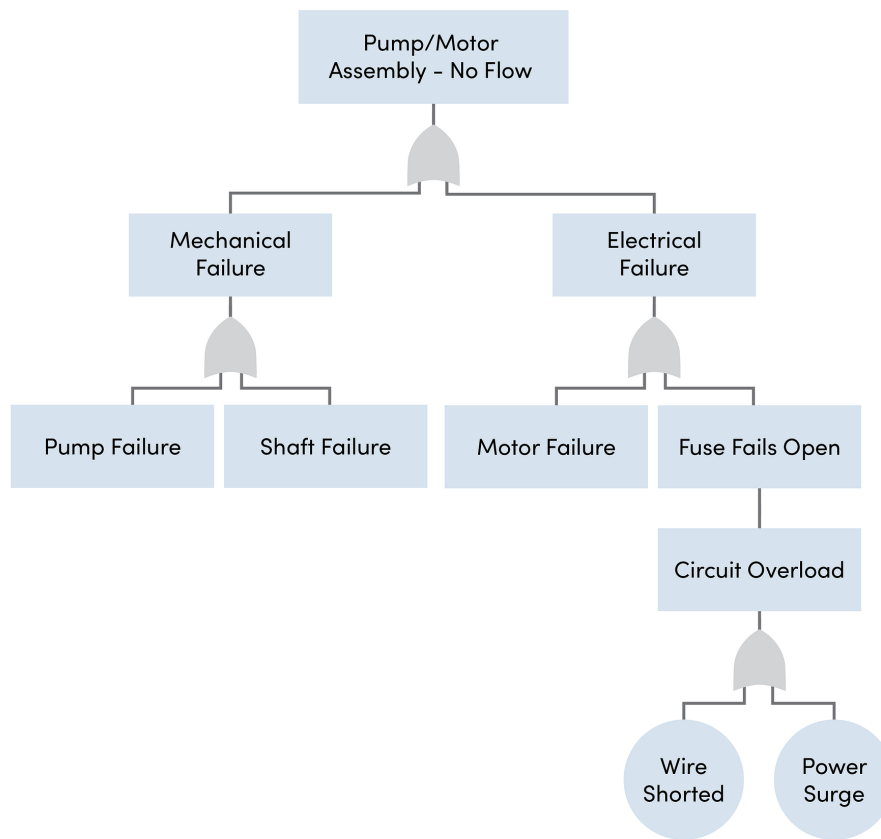

Figure 28. Fault tree Analysis

FTA enables the development of a hierarchical failure model, visually demonstrating how individual component failures propagate through the system, ultimately leading to the top-level failure. This approach helps engineers understand the interactions between failures, supporting better system design and fault prevention strategies (J. Sun et al., 2022; Xia et al., 2024).

### 5.5.2 Why Use FTA in System Reliability?

FTA is particularly valuable in system reliability because it provides a detailed understanding of the interdependencies between components and their effects on overall system performance. Here are several reasons why FTA is used in reliability analysis:

#### Identifying Failure Causes

FTA allows engineers to identify the root causes of system failures by breaking down the failure process into its underlying components. This helps to pinpoint specific vulnerabilities in the system, making it easier to target these areas for improvement. By visualizing all the possible ways a system can fail, engineers can design more robust solutions to prevent these failures (Boryczko et al., 2022a; G.-J. Jiang et al., 2019).

### **Predicting Failure Propagation**

In complex systems, component failures rarely happen in isolation. FTA helps predict how failures propagate from one component to another and how multiple component failures can combine to cause system-wide failures. This is essential for safety-critical systems, such as those in aerospace, nuclear power, and healthcare, where cascading failures can have catastrophic consequences (Cui et al., 2023; Deyter et al., 2009).

### **Improving Redundancy and Fault Tolerance**

FTA highlights where redundancies need to be introduced to prevent single points of failure. By analyzing the fault tree, engineers can see how adding parallel components or improving fault-tolerant design can prevent a system failure even when one or more components fail (J. Sun et al., 2022; Zhilong & Jinping, 2022).

### **Quantifying System Reliability**

FTA can be combined with probabilistic failure data (such as failure rates of individual components) to quantitatively assess system reliability. By assigning probabilities to basic events, engineers can calculate the likelihood of the top-level event, providing a numerical estimate of overall system reliability (Adumene et al., 2021; Jakkula et al., 2020).

#### 5.5.3 Fault Tree Analysis (FTA) in System Reliability

Fault Tree Analysis (FTA) is a vital method in system reliability engineering that provides a structured, top-down approach to understanding the potential causes of system failures. It creates a visual representation of how component failures interact and propagate, helping engineers predict and mitigate system breakdowns. FTA starts with a top-level event typically a system failure and traces backward through logical gates to identify the underlying causes of that failure. This method is particularly valuable for analyzing interdependencies between components, allowing engineers to visualize and calculate how minor failures can escalate into significant system disruptions.

FTA's hierarchical structure allows us to trace failures from individual components (basic events) to their broader impact on the system as a whole. This component-to-system view is crucial for understanding how even small, localized component failures can lead to larger system failures. For instance, in an unmanned aerial vehicle (UAV), the top-level event in the fault tree might be a catastrophic crash. The basic events contributing to this failure could include issues such as a propeller motor failure, loss of communication signals, or a GPS sensor malfunction. The fault tree would illustrate how these basic events, either individually or in combination, lead to the top-level system failure. Logical AND gates might represent situations where both the motor and backup motor must fail for the UAV to crash, while OR gates might indicate scenarios where the failure of either the communication system or navigation system would independently cause the crash.

This system-level perspective allows engineers to map out how individual failures propagate and combine to cause catastrophic system failures. For example, in a power grid, the failure of a transformer alone may not directly lead to a blackout. However, when combined with the failure of backup generators and safety circuits (through AND gates), the likelihood of a large-scale outage

increases significantly. FTA helps identify these potential failure paths and suggests where redundancies or preventive measures (like improving backup systems) can be introduced to enhance system resilience.

### 5.5.4 Defining Overall System Reliability Using FTA

In Fault Tree Analysis, overall system reliability is determined by calculating the probability that the top-level event (system failure) does not occur. This is done by evaluating the likelihood of component-level failures and how they combine through logical gates to impact the system. To calculate system reliability, we follow a step-by-step process:

1. Assign Failure Probabilities to Basic Events:

Each basic event, such as the failure of a motor or a sensor, is assigned a failure probability based on historical data or probabilistic models, like the Weibull distribution (Boryczko et al., 2022b; Sonawane et al., 2023).

2. Analyze Gate Combinations:

Using the AND and OR gates, the probabilities of intermediate events are calculated. For an AND gate, the probability of the intermediate event is the product of the failure probabilities of the connected basic events. In the case of an OR gate, the probability is calculated as the chance that any one of the connected basic events occurs (Boryczko et al., 2022a; Ding et al., 2021).

3. Calculate the Probability of the Top-Level Event:

By combining the results from intermediate events, we calculate the probability of the top-level event—in this case, system failure. This probability provides a quantitative measure of how likely it is for the system to fail (Akhtar & Kirmani, 2022; Shu et al., 2020).

4. Determine System Reliability:

The overall system reliability  $R_{\text{system}}$  is then the complement of the top-level failure probability:

$$R_{\text{system}} = 1 - P_{\text{failure}} \quad (6)$$

Where  $P_{\text{failure}}$  is the probability of the top-level event (e.g., catastrophic failure). A lower probability of failure means higher system reliability (Jakkula et al., 2020; H. Jiang et al., 2022).

### 5.5.5 FTA's Role in Enhancing System Reliability

Fault Tree Analysis (FTA) plays a pivotal role in system reliability engineering by offering a structured approach to identify and understand the causes of system failures and their interdependencies. FTA provides a detailed component-to-system view, illustrating how individual failures can combine to trigger significant system-level events. By tracing how basic events lead to critical system failures, FTA helps engineers identify vulnerabilities, quantify system reliability, and develop strategies to mitigate risks.

FTA will be particularly useful for:

- Identifying failure modes at the component level and tracing their impact on the overall system (Yazdi et al., 2023).
- Quantifying system reliability, enabling you to calculate the likelihood of catastrophic failures based on component failure probabilities and how they propagate through the system (Akhtar & Kirmani, 2022; Mohammadi et al., 2021).
- Improving system design by pinpointing where redundancies and preventive measures can be implemented to mitigate failure risks and improve resilience (H. Sun et al., 2022).

By systematically analyzing the fault tree, your research can provide valuable insights into enhancing system reliability, particularly in complex, interdependent systems. This approach will ensure that potential failure paths are well understood, anticipated, and mitigated, leading to more robust and resilient system designs.

### 5.6 Validation and verification of the logical view

The logical view, as the final level of analysis, allows us to ascend through the structure of the system, examining the impact of various components on overall reliability while taking into account potential material or functional redundancies. For essential functions, particularly those related to safety, internal redundancies are built in to increase reliability. In complex engineering systems, the logical view is critical for understanding how component failures affect overall system reliability. The U-Cycle approach integrates the logical view with structural, temporal, and physical perspectives, to provide a comprehensive framework for reliability modelling. This section outlines the validation and verification of the logical view within the U-Cycle approach and highlights its role in improving system reliability.

#### **The role of logical view in the U-Cycle approach**

The logical view is designed to evaluate the influence of different system components on overall reliability, taking into account material and functional redundancies. This view is integral to the U-Cycle approach, which combines multiple perspectives to provide a holistic understanding of system behaviour and performance shown in the Figure 29.

## Logical View

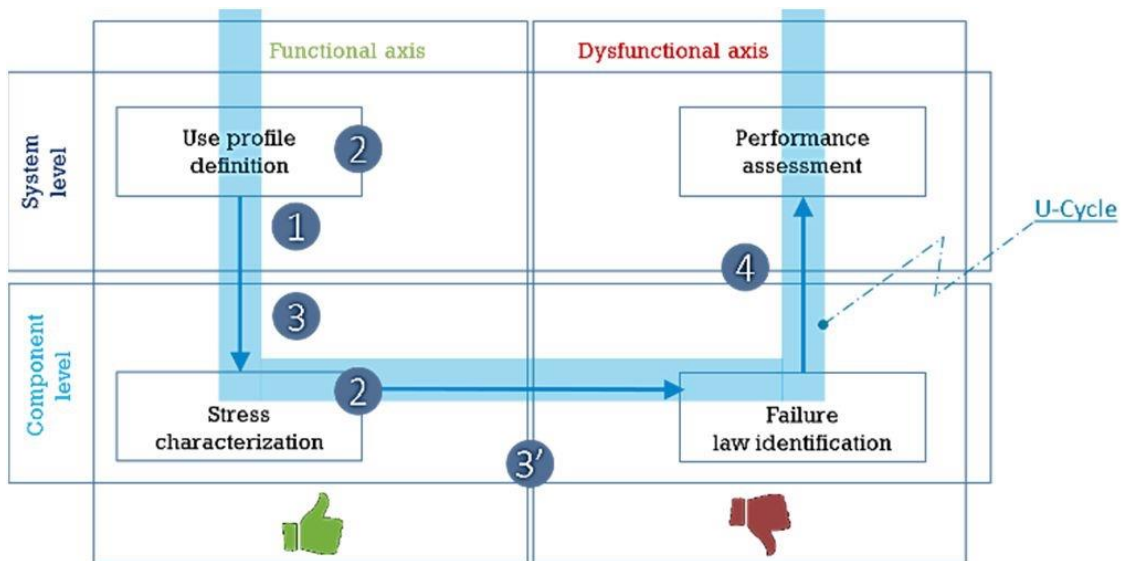

Figure 29. Spot 4 U-cycle approach

Building on the advanced methodologies outlined in the previous section, this part of the chapter aims at improving reliability indicators specifically within the logical view framework. By integrating sophisticated analytical techniques and real-time monitoring systems, we can significantly improve the accuracy of reliability assessments. The following sections will explore how these enhanced reliability indicators are applied within the logical view to ensure a more resilient and fault-tolerant system architecture. This comprehensive approach not only refines our understanding of component behaviours under varying conditions but also supports proactive maintenance strategies, ultimately leading to improved system performance and operational safety. In the field of complex engineered systems, reliability assessments are critical for ensuring the robustness and safety of system operations. The logical view plays a key role in these assessments by representing the relationships and dependencies between system components, subsystems, and their overall impact on system reliability. Improving the credibility and accuracy of the logical view requires the refinement of methodologies to better characterise failure rates, especially considering the complexity at the component, subsystem, and system levels. This involves several key initiatives involved advanced data collection techniques, sophisticated statistical analysis, context-specific modelling, and continuous monitoring. Each of these initiatives contributes to a more robust and reliable logical view, ultimately improving overall system reliability.

### 1. Advanced data collection techniques

The advent of modern technologies such as sensors and the Internet of Things (IoT) has revolutionised data collection processes, particularly in complex engineering systems. These technologies enable real-time data collection on component performance and failure rates, providing a rich and dynamic data set for logical modelling. Sensors embedded in system components can continuously monitor

operational parameters, detect anomalies, and record failure events with high accuracy. IoT devices facilitate the seamless integration of this data into centralised databases, enabling for comprehensive and up-to-date data collection. This real-time data is critical for accurately characterising failure rates and understanding the dynamic behaviours of system components under different conditions.

By using these advanced data acquisition techniques, reliability engineers can gain a granular view of component performance. This data can be used to identify trends, detect early signs of potential failures, and understand the root causes of failures. In addition, incorporating real-time data into reliability assessments ensures that the logical view remains current and reflects of the actual operating environment, increasing its accuracy and credibility.

### ***2. Statistical analysis and modelling***

The application of advanced statistical methods and machine learning algorithms is essential to improve the understanding and prediction of failure behaviours in complex systems. Traditional statistical techniques such as regression analysis, survival analysis, and reliability block diagrams have been widely used to model failure rates. However, these methods often rely on assumptions that may not hold true in complex, real-world systems.

Machine learning algorithms, on the other hand, can uncover hidden patterns in large data sets and make accurate predictions without requiring explicit assumptions about the underlying distribution of failure times. Techniques such as neural networks, decision trees, and random forests can be used to model the complex relationships between the various factors that influence component reliability. These models can be trained on historical data to predict future failure rates, identify high-risk components, and recommend preventive maintenance actions. In addition, Bayesian methods can be used to update reliability models as new data becomes available, enabling continuous refinement and improvement of failure rate predictions. This combination of statistical analysis and machine learning provides a powerful toolkit for enhancing the logical view in reliability assessment.

### ***3. Context-specific models***

Developing models that are tailored to the specific operational contexts and environments in which components operate is critical for accurate reliability assessment in complex engineered systems. Generic models that do not take for contextual factors into account can lead to inaccurate predictions and misguided maintenance strategies. Context-specific models, on the other hand, take into consideration the unique operating conditions, load profiles, and environmental factors that affect component reliability. For example, the failure rate of a component in a high temperature environment may be significantly different from that in a low temperature environment. Similarly, components subjected to variable load conditions may exhibit different failure behaviour than those operating under constant load. By incorporating these contextual factors into reliability models, engineers can gain a more accurate and nuanced understanding of failure mechanisms. Contextual models can be developed using a combination of domain expertise and data-driven approaches. Historical data on component performance under different conditions can be used to calibrate these models, ensuring that they accurately reflect the operational realities of the system.

### 4. *Continuous monitoring and updating*

The implementation of continuous monitoring systems is essential to dynamically update failure rate models based on new data and observed changes in operating conditions. Traditional reliability assessments often based on static models that do not take into account for the evolving nature of system operation. Continuous monitoring allows for the real-time collection and analysis of performance data, enabling the detection of emerging failure trends to be identified and reliability models to be updated in a timely manner.

Continuous monitoring systems can be integrated with advanced analytics platforms that automatically process incoming data and update failure rate predictions. These systems can alert maintenance teams to potential problems before they become in failures, facilitating proactive maintenance and reducing downtime. In addition, continuous monitoring supports the development of adaptive reliability models that can adapt to changing conditions. For example, if a system experiences an increase in load or a change in operating environment, the reliability model can be updated to reflect the new conditions, ensuring that reliability assessments remain accurate.

## 5.6 Conclusion

Improving the reliability indicators for the logical view requires a multi-faceted approach that integrates advanced data collection techniques, sophisticated statistical analysis, context-specific modelling, and continuous monitoring. Through these initiatives, we can improve the accuracy and credibility of complex systems, leading to more reliable system operation and better informed maintenance decisions. Continuous refinement and updating of these models ensures that they continue to reflect the actual operating environment, providing a robust basis for reliability

assessments. By implementing these strategies, organisations can achieve a higher level of reliability in their systems, ultimately leading to improved performance, reduced downtime, and lower maintenance costs. This comprehensive approach to improving reliability metrics represents a significant advance in the field of reliability engineering and contributes to the development of more resilient and reliable systems.

In the next chapter, we will look at the practical implementation of these concepts. We will explore the application of the U-cycle approach to multiscale modelling, and demonstrate how this methodology can improve the accuracy and utility of reliability assessments. In addition, we will introduce Bayesian networks as a powerful tool for holistic modelling within a unified methodological framework. This will be further illustrated by a case study based on a real industrial system. Although the specifics of the case are fabricated for illustrative purposes, it will effectively demonstrate the different steps of this conceptual approach to reliability assessment using qualitative modelling. The case study will focus on the selected instrumentation and the use of Bayesian networks, highlighting their potential to provide a comprehensive and integrated view of system reliability. This practical example will provide valuable insights into the application of advanced modelling techniques in real-world scenarios and highlight the benefits of a unified approach to reliability engineering.





# **Chapter VI**

# **U-Cycle Approach**

# **Instrumentation**

## 6.1 Introduction to U-cycle approach in multiscale modelling

As we transition from the theoretical and conceptual modeling explored in the preceding chapters, Chapter 6 delves into the operational aspects of the U-Cycle approach. Building on the reliability-focused logical structures and redundancy configurations examined in Chapter 5, this chapter integrates these insights with a comprehensive multiscale modeling framework. The U-Cycle approach emphasizes a holistic understanding of system reliability by addressing the interplay between functional stresses, component durability, and environmental factors. This final chapter focuses on the implementation of advanced tools and methods, enabling the simultaneous analysis of various system perspectives, a key challenge identified in previous chapters.

To move from a conceptual framework to a more operational methodology, this chapter presents an inventory of tools and methods that are essential to support the multiple perspectives inherent in the U-cycle approach. These tools, based on different concepts with specific objectives and characteristics, play a critical role in the specification, structuring, representation, visualization, evaluation, and inference processes required for comprehensive analysis.

The U-cycle approach encompasses a variety of perspectives, each of which has been developed independently using different tools. While these tools vary in their effectiveness, they generally do not allow for the simultaneous consideration of multiple perspectives, thus limiting a holistic analysis. This chapter addresses this gap by systematically cataloguing the available tools and methods, highlighting their respective strengths and limitations, and suggesting ways to integrate them effectively within the U-cycle framework. The tools and methods identified include, but are not limited to, advanced computational techniques and machine learning algorithms, that are critical to improving the predictive capabilities and reliability assessments of complex systems. The chapter emphasizes need to adopt a multi-tool strategy to address the intricate dependencies and uncertainties that characterize multiscale modeling.

By leveraging these tools, the U-cycle approach aims to provide a more unified and robust framework for reliability analysis. This framework not only addresses the functional stresses and physical durability of components but also integrates the probabilistic nature of system behavior and environmental factors. Instrumenting the U-cycle approach with these machine learning techniques provides a robust framework for reliability analysis. This chapter details the implementation process, presents a case study demonstrating its practical application, and compares the results with traditional approaches to highlight the advantages and limitations of the proposed methodology. The Table below briefly summarizes the positioning of these different tools.

## 6.2 Tool specification for instrumenting U-Cycle approach

### 6.2.1 Parameters for U-Cycle implementation

Successful implementation of the U-cycle approach depends on several key parameters, that the selected tools must meet. These parameters include:

### 1) Structural view parameters:

#### *System hierarchy:*

The system hierarchy involves creating a comprehensive map of the system by breaking it down into its constituent subassemblies and components. This detailed description of the system architecture shows how each subassembly fits into the larger system. This is typically represented using diagrams such as block diagrams, flowcharts, or Sys ML (Systems Modeling Language) diagrams.

For example, consider the system hierarchy of an aircraft's flight control system. The hierarchy would include major components such as the cockpit controls, flight control computers, actuators, and control surfaces such as ailerons, elevators, and the rudder. Each of these major components can be further broken down into smaller subcomponents. For example, the flight control computers might be decomposed into processors, power supplies units, and communication interfaces. This hierarchical mapping helps to understand the structure and function of each component and how they interact within the overall system.

This part of the structural view also specifies the relationships between assemblies. This includes detailing how different subassemblies are connected and interact within the system. Connections can include mechanical joints, electrical wiring, and data communication links. For example, in the context of an aircraft flight control system, the relationships would detail how the cockpit controls (such as the joystick) are connected to the flight control computers via wiring harnesses and how these computers send commands to the actuators via data buses. This interconnected network of components and subassemblies forms the backbone of the system's functionality (Sghairi *et al.*, 2009).

#### *Component characteristics:*

Each component in the system must be specified in detail. This includes documenting the physical dimensions, weight, material properties, and other relevant physical characteristics of the components. For example, for an actuator within the flight control system, the specifications would include its maximum force output, range of motion, and electrical input requirements.

In addition to physical specifications, it is critical to understand the operational limits of each component. These limits define the boundaries within which the component is designed to operate safely and effectively (Puebla and Munjulury, 2015). Exceeding these limits can result in component failure. Operational limits include factors such as load capacities, voltage, current, temperature, pressure, and other stressors that the component may encounter during operation. For example, an actuator might have a specified operational temperature range of 0 to 50 degrees Celsius and a load capacity of up to 1000 Newtons (Actuatos, 1976).

Understanding component failure modes is another critical aspect of structural view parameters. Failure modes describe the ways in which a component can fail and the conditions under which these failures occur. This involves identifying potential failure points, the causes of those failures, and their

effects on the overall system. For example, an actuator may experience mechanical jamming due to debris, electrical failure due to overheating, or wear and tear of moving parts. Analyzing these failure modes helps to understand their impact on the system performance and to develop strategies to mitigate such risks (Röben, 2018).

### **2) Temporal view parameters:**

#### ***Mission profiles:***

Mission profiles are a detailed definition of the use of the system over time, capturing the different operational conditions and the expected duration of each operational phase at different hierarchical levels. It describes how the system will be used during its life cycle, including the sequence of activities, the duration of each activity, and the conditions under which these activities will occur. (*Introduction — Mission Profile Format Documentation (Version 0.7.1)*).

For example, in the context of an aircraft, a mission profile would detail the entire flight process from start to finish. This would include phases such as pre-flight checks, taxiing, takeoff, cruising, descent, landing, and post-flight operations. Each phase has specific operating conditions, such as the stress on the aircraft during takeoff or the environmental conditions encountered during high altitudes cruising. The mission profile for each phase must specify the expected duration and the typical conditions under which the system will operate. This helps to understand how the system is used in real-world scenarios and to identify the stresses and demands placed on the system components during each phase of operation.

#### ***Phase transitions:***

Phase transitions involve characterizing of the changes between different operational phases and their effects on the system components. This means understanding how the system transitions from one operational state to another and how these transitions affect the components.

Using the aircraft example, phase transitions would detail how the aircraft moves from taxiing to takeoff, from cruise to descent, and so on. Each transition is critical because it involves changes in operating conditions that can affect the system components differently. For example, the transition from takeoff to cruising involves a rapid change in altitude and airspeed, which can place significant stress on the aircraft's engines and airframe. Similarly, the transition from cruise to descent involves changes in pressure and temperature, that can affect various systems on the aircraft. Understanding phase transitions helps to analyze the transient stresses and loads that components experience during these changes. This includes examining how quickly the transition occurs, the magnitude of the changes, and the duration of the transient states. By characterizing these transitions, engineers can predict potential failure points and design components to withstand the stresses associated with these operational changes (Baspnar, Balakrishnan and Koyuncu, 2020).

### **3) Physical view parameters:**

#### ***Induced phenomena:***

Induced phenomena refer to the identification and characterization of the various physical stresses and conditions that affect the system during its operation. This includes understanding how different

types of stresses, such as thermal, mechanical, and electrical, affect the system and its components. For example, thermal stress can be caused by changes in temperature, which might lead to expansion or contraction of materials, potentially causing fatigue or failure over time. Mechanical stress could result from forces applied to the system, such as vibration or shock, which could cause structural deformation or wear. Electrical stress can involve variations in voltage or current, that can cause overheating or electrical failure. By identifying these phenomena, engineers can better understand the operating environment of the system and design components that can withstand these stresses (Patchev and Patchev, 2006).

### ***Failure mechanisms:***

Failure mechanisms involve a detailed analysis of the potential ways in which system components could fail and the damage that such failures could cause. This includes examining how various stresses and loads can lead to component degradation and eventual failure. For example, repeated thermal cycling might cause solder joints in electronic components to crack, while constant mechanical vibration can lead to material fatigue and failure in structural components. Understanding these mechanisms helps predict the lifetime of components and the conditions under which they are likely to fail. This analysis is critical for designing components that are robust and reliable under the expected operating conditions (Understanding Failure Mechanisms and Components / Reliability, 2023).

### **4) Logical view parameters:**

#### ***Functional redundancies:***

Functional redundancies refer to the representation of duplicate components or systems within the larger system to improve overall reliability. This involves modeling how redundancy can prevent system failure by providing backup components to take over if the primary components fail. For example, in an aircraft, multiple redundant flight control systems ensure that if one system fails, others can continue to operate, and maintain control of the aircraft. Redundancy is essential for critical systems where failure is not an option, as they significantly increase reliability by reducing the likelihood of complete system failure (Eşer, Yıldız and Türe, 2024).

#### ***Reliability measures:***

Reliability measures involve quantitative assessments of the reliability of the system, taking into account the effects of redundancies and the failure rates of individual components. This includes calculating metrics such as mean time between failures (MTBF), failure rate, and system availability. By incorporating component reliability data and the effects of redundancy, engineers can predict the overall reliability of the system and identify critical components that might require more robust designs or additional redundancy. These actions are critical to ensuring that the system meets the required reliability standards and performs reliably under expected conditions.

This chapter presents an inventory of tools and techniques essential for instrumenting the U-Cycle approach, addressing both the strengths and limitations of available methods. By doing so, it outlines a strategy for integrating these tools into a cohesive framework that not only evaluates system reliability but also improves it through iterative learning and adaptation. To move from a conceptual framework to a more operational methodology, we propose an inventory of tools and methods capable

of supporting the different views that characterize the U-Cycle approach. These tools, based on distinct objectives and specific characteristics, are critical for specification, structuring, representation, visualization, evaluation, or inference processes required for comprehensive analysis.

6.2.2 Frameworks and Tools for System Reliability Analysis Across Different Views

The table below provides a detailed breakdown of these tools across various views. It highlights how different tools contribute to the structural, temporal, and physical modeling, as well as the logical and dysfunctional aspects of system reliability. For each view, a combination of deterministic and stochastic frameworks can be applied to improve system analysis and predictive reliability.

Views	Spot	Objectives	Tools	
			Deterministic framework	Stochastic frame
<i>Structural View</i>	1	Specify the system and establish a preliminary architecture for reliability assignment. This view is supported by the system engineering approach. This approach allows the realization of an organized set of models, applying at different levels of granularity such as the operational aspect (context and use of the system), the functional aspect (structure and sub-functions of the system), and the physical aspect (architecture).	Based on the use of SysML, this approach relies on the use of class diagrams, structure diagrams. They can be complemented by other representation and structuring approaches such as SADT/IDEF0.	N/A
<i>Temporal view</i>	2	Define the dynamic aspects associated with usage profiles and phased missions. From a structural point of view, each sub-system or component is described in terms of processes that characterize the activities and phases involved according to the requirements to which it must respond.	At a metamodeling level, the UML language can be used. On an operational level, time series or chronological series allow to order and quantify the duration of the elementary phases of the system under consideration. The representation can then be done using process modeling tools (BPMN, flowcharts...).	Since the duration of the descriptive phases of a system's behaviour can be random, tools such as Stochastic Petri Nets or discrete or continuous Markov chains can be used for stochastically represent mission profiles.
<i>Functional Physical view</i>	3	Analytically and/or graphically represent the	Bond Graphs can be used here. They allow, from a	Monte-Carlo techniques can be superimposed on physical

## U-Cycle Approach Instrumentation

		physical behavior of components and the energy transfers between system components. Determine, quantify and visualize the physical laws governing the system and the flows emitted and received by the system components according to the system architecture and its use.	standard formalism, the multi physical representation of components of different natures (mechanical, electrical, hydraulic, etc.) The behavior of an organ is characterised by two generalised variables: effort and flow. The instantaneous power exchanged between elements is expressed by the product of these two variables.	laws when these are formulated analytically. Taking into account random variables as an input of the models then enables probabilistic values to be collected at the output or framed by confidence intervals.
<b><i>Dysfunctional physical view</i></b>	3'	Translate the physical behavior of the system into dysfunctional terms (mechanisms of deterioration and laws of reliability). Convert the stresses received by the components in the form of energy flows into measures of reliability performance.	Degradation laws based on threshold or fatigue criteria	FMEA or HAZOP-type methods can be used to evaluate the criticality criticality of failure modes at different structural levels. " Stress resistance" methods can also be used to estimate the probability of component failure as a function of the degree of overlap between the damage distribution and the theoretical strength distribution. The statistical distribution of the failure times also allows the definition of reliability laws (Weibull, Erlang, Lognormal,).
<b><i>Logical view</i></b>	4	Evaluate the performance of the different subsystems based on knowledge of the reliability behavior of their constituent elements. Aggregate the reliability behavior of the elementary components to feed information up to the higher system levels.	Modeling and dynamic simulation tools	Several tools have been developed to characterize the logical view such as: Fault trees, reliability diagrams, Markov chains, Petri stochastic networks, dynamic programming, formal languages

**Table II Inventory of Tools and Methods for the U-Cycle Approach**



## 6.3 Unifying modelling approach

It would be an understatement to say that there has been little work done on the connection between the different views of the U-cycle as we have described them. Part of the reason why reliability approaches are still struggling to reproduce the behaviour of a system today is the inability to model in the same approach the functional stress received by the components and their ability to withstand the physical pressure they are subjected to. As we have just seen, the academic actors have mainly concentrated their efforts on local problems describing incompletely or approximately the impact on the reliability of the system of the deterioration mechanisms brought into play by its use. To the credit of the scientific community, it must be acknowledged that the task is eminently tricky due to the complexity of the physical laws involved and the uncertainties associated both with the behaviour of the system and the determination of the aggressive nature of its environment. An alternative to decoupled approaches may then come from the use of global models based on artificial intelligence techniques and, in particular, machine learning.

Machine learning is based on data analysis and allows the development of models by identification of patterns used to make predictions from statistical data. The instrumentation of the U-cycle approach can benefit from the use of these Machine Learning techniques. To ensure a robust integration of the structural, temporal, physical, and logical views into a unified modelling framework, a process-driven knowledge model is proposed. This model structures how data flows, dependencies, and constraints interact within the U-cycle approach. By defining data collection, processing, and analysis steps, the framework provides a systematic way to unify different reliability assessment techniques. The integration of AI techniques (neural networks) and Bayesian networks within this framework allows for dynamic reliability assessment by continuously updating system models with real-time and historical data. However, for the approach to be practically operational, an information model is needed to formalize the relationships between system views, stress factors, and reliability constraints. Future work should focus on developing a structured ontology that enables automated reasoning about system reliability and its influencing factors.

### 6.3.1 Discussion on tools

The proposed methodology, therefore, represents a significant advancement in the field, providing a more accurate and comprehensive understanding of system reliability. Two key tools are likely to support the entire modelling of the approach:

#### 6.3.1.1 *Neural network*

Artificial neural networks (ANNs) mimic essential features of biological behavior, such as learning, generalization, and association ([Mhapsekar and Sharma, 2023](#)). ANN behavior involves two phases: activation, which processes input data to identify patterns, and propagation, which uses these patterns to make predictions or decisions. Neural networks excel in handling large datasets and complex relationships, making them suitable for modeling intricate dependencies in complex systems ([Rahul, 2023](#)). Applying machine learning techniques within the U-cycle approach can significantly enhance its predictive capabilities, allowing for more accurate assessments of system reliability under various

conditions. The activation phase is where the input data is processed to identify patterns. Each neuron in the network receives input signals (denoted as  $X_1, X_2, \dots, X_m$ ) from multiple sources. Each input signal is associated with a synaptic weight (denoted as  $W_{ij}$ ) which represents the strength of the connection between the neurons.

The neuron processes these inputs by calculating a weighted sum, which is the sum of the products of each input signal and its corresponding weight. Mathematically, this

$$a_i = \sum_j W_{ij} \varepsilon_j \quad (7)$$

Where  $a_i$  is the activation level of the neuron  $i$ ,  $W_{ij}$  is the weight of the connection between neuron  $i$  and input  $j$ , and  $x_j$  is the input signal  $j$ .

Once the weighted sum is computed, it is passed through an activation function (often a nonlinear function such as sigmoid, tanh, or ReLU). This function determines the output of the neuron based on its activation level. The result is the neuron's output value, which is passed onto other neurons in the network.

### ***Propagation Phase:***

In the propagation phase, the output values from the activation phase are transmitted to downstream neurons. The connections between neurons, characterized by synaptic weights, allow the network to model complex relationships and patterns in the data. The output from one neuron becomes the input to the next layer of neurons, allowing the network to propagate the signals forward through the layers.

This process of passing information from the input layer, through hidden layers, and finally to the output layer, allows the neural network to perform complex computations and make predictions or decisions based on the input data.

By applying machine learning techniques such as ANNs within the U-cycle approach, the predictive capabilities of the system can be greatly enhanced. ANNs can analyze large amounts of data to identify patterns and dependencies that may not be apparent using traditional analytical methods. This allows for more accurate assessments of system reliability under varying conditions, as the neural network can learn from historical data and continuously improve its predictions. From this, a transfer function calculates the value of the neuron's state. (Fig. 30).

## U-Cycle Approach Instrumentation

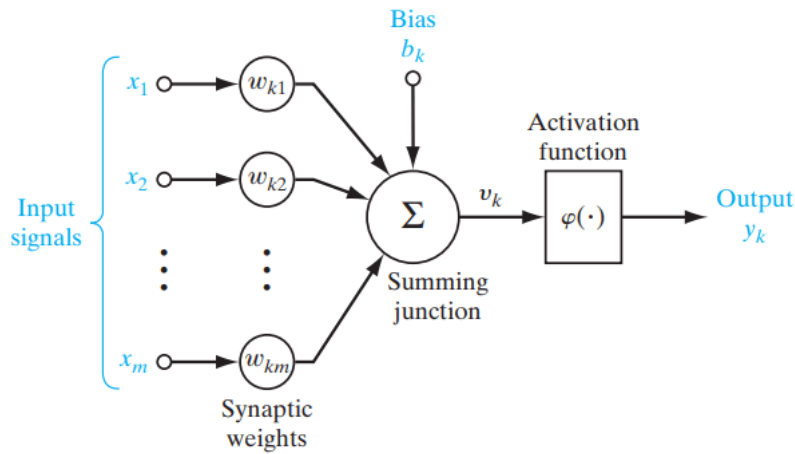

Figure 30. Model of neuron

This value is then transmitted to the downstream neurons. The connection between the neurons then makes it possible to model the reasoning process via a network (Fig. 31). This diagram illustrates a network of interconnected neurons. The connections between neurons, represented by synaptic weights, form a network that processes input data through multiple layers, allowing the network to learn and make complex decisions.

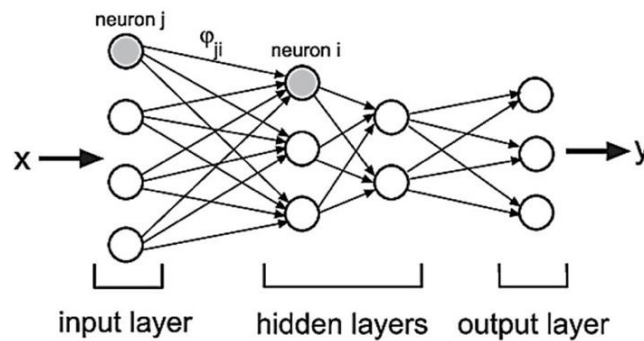

Figure 31 Neural network (Bouhamed et al., 2015)

### 6.3.1.2 Bayesian network

Bayesian networks are graphical models that represent probabilistic relationships among variables. They are particularly effective in dealing with uncertainty and complex interdependencies, that are common in multi-scale modeling. Integrating bayesian Networks with the U-cycle approach allows for systematic incorporation of the probabilistic nature of system behaviors and environmental factors into the reliability analysis. This integration provides a comprehensive understanding of potential failure modes and their effects on the overall system.

In the quest to improve the reliability and performance of complex systems, Bayesian Networks (BNs) have emerged as a central analytical tool, providing a nuanced framework for understanding

and managing the intricacies of system behaviors and uncertainty. As articulated in seminal works and contemporary research, BNs are probabilistic graphical models that represent a set of variables and their conditional dependencies via a directed acyclic graph (Jensen, 2001). This approach allows the quantification and analysis of the probabilistic relationships between different system components, facilitating a comprehensive assessment of system reliability and performance. The utility of BNs in system reliability analysis lies in their ability to model complex, stochastic systems where traditional analytical methods may fall short. For example, K. Murphy's "Machine Learning: A Probabilistic Perspective" (Murphy, 2012) provides a fundamental understanding of the theoretical underpinnings of BNs, emphasizing their ability to incorporate both prior knowledge and new evidence to update beliefs about the state of the system. This dynamic updating process is critical for real-time reliability assessment and decision making in engineering applications.

In addition, in the field of engineering and reliability studies, the application of BNs extends to predicting failures, optimizing maintenance schedules, and improving system design for robustness. A notable example is presented by E. Zio in "The Use of Bayesian Networks for Reliability Analysis" (Reliability Engineering & System Safety, 2009), where BNs are used to address the complexities and uncertainties inherent in the operation of nuclear power plant. Zio's work exemplifies how BNs can integrate diverse data sources, including expert judgement and empirical data, to provide a probabilistic assessment of system reliability, thus supporting more informed and robust engineering decisions (Zio, 2009). Incorporating BNs into the U-cycle methodology, which encompasses the phases of understanding, use, and upgrade phases of systems, provides a structured approach to optimising reliability and performance. Through the lens of BNs, system reliability is viewed not as a static attribute but as a dynamic property that evolves with new information and operational experience. This perspective is consistent with the iterative nature of the U-cycle methodology, which emphasizes continuous improvement and adaptation to changing conditions and requirements. Bayesian networks provide a profound methodological advance for system reliability analysis, bridging the gap between complex system behaviors and practical reliability engineering practice. Their ability to model uncertainty, incorporate data from multiple sources, and facilitate decision making underlies their importance in advancing the field of reliability engineering, particularly within the context of the U-cycle methodology aimed at improving system resilience and performance.

Bayesian Networks (BNs) are a class of graphical models that represent a set of variables and their conditional dependencies via a directed acyclic graph (DAG) (Jensen, 2001). They are a powerful tool for modeling uncertainty in complex systems, making them particularly useful for system reliability analysis. At their core, Bayesian networks combine principles from graph theory, probability theory, and statistics to provide a comprehensive framework for probabilistic inference. (Koller and Friedman, 2009).

The fundamental formula underlying Bayesian networks is based on Bayes' theorem, which is generally stated as follows:  $P(A/B) \cdot P(B) = P(B/A) \cdot P(A)$

$$P(A|B) = \frac{P(B|A) \cdot P(A)}{P(B)} \quad (8)$$

where:

- $P(A|B)$  is the posterior probability of A given B
- $P(B|A)$  is the probability of B given A
- $P(A)$  is the prior probability of A, and
- $P(B)$  is the probability of B

In the context of Bayesian networks, the joint probability distribution of a set of variables  $X_1, X_2, \dots, X_n$  can be decomposed into a product of conditional probabilities using the chain rule of probability.

$$P(X_1, X_2, \dots, X_n) = P(X_1) \cdot P(X_2 | X_1) \cdot P(X_3 | X_1, X_2) \cdot \dots \quad (9)$$

$$P(X_n | X_1, X_2, \dots, X_{n-1}) \quad (10)$$

Given the DAG structure of a BN, where each node represents a variable and edges represent conditional dependencies, the joint distribution simplifies to :

$$P(X_1, X_2, \dots, X_n) = \prod_{i=1}^n P(X_i | Parents(X_i)) \quad (11)$$

Here,  $Parents(X_i)$  denotes the set of parent nodes of  $X_i$  in the graph, reflecting the direct dependencies. This factorisation allows for efficient computation of the probability of any event in the network, given some evidence, through algorithms such as belief propagation (Koller and Friedman, 2009). Bayesian Networks and neural networks are well suited to represent the different views of the U-cycle approach ([Wilson and Huzurbazar, 2007](#); [Ben Hassen et al., 2013](#); [Guo, Li and Keyser, 2018](#); [Guo, \(Steven\) Li and \(Judy\) Jin, 2018](#); [Villeneuve et al., 2023](#)).

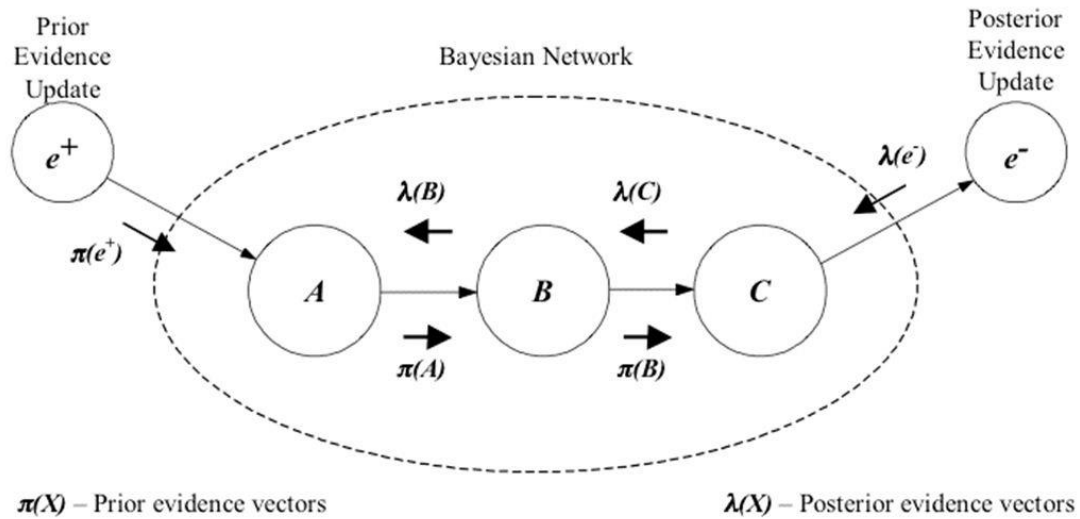

Figure 32. Bayesian network

Bayesian networks are particularly suited to system reliability analysis because they can model the complex interdependencies between system components and account for uncertainty and partial knowledge. They allow for dynamic updating of reliability predictions as new information becomes available, facilitating more informed decision-making regarding maintenance and system design decisions (Jensen, 2001).

### 6.3.1.3 Rational for tools selection

In the context of the U-cycle approach, both Bayesian networks (BNs) and Neural networks (NNs) present viable options for modeling complex systems due to their ability to handle classification tasks and their reliance on learning concepts. However, a deeper analysis reveals significant differences that make Bayesian Networks more suitable for our specific application.

#### *Similarities between bayesian networks and neural networks*

Both BNs and NNs use directed graphs and are applicable in classification operations, which fits well within the general framework of our work. These tools are based on learning concepts, and use both supervised and unsupervised learning methods.

Supervised learning algorithms are trained on labeled examples. These algorithms are given a set of inputs along with the corresponding correct outputs, allowing them to learn by comparing the generated outputs with the expected results. They then adjust the model to minimize errors, using methods such as classification, regression, and prediction to identify patterns and predict values for unlabeled data. This approach is often used in applications where historical data is used to predict future events.

Unsupervised learning, on the other hand, is applied to data without historical labels. In this scenario, the system must autonomously understand the data presented, and explore it to uncover inherent structures ([Correa, Bielza and Pamies-Teixeira, 2009](#)).

### *Differences between bayesian networks and neural networks*

Despite their similarities, bayesian network and neural network have distinct differences that affect their applicability in our work. bayesian networks provide a meaningful visual representation of the graph through vertices and arcs, which depict conditional dependencies between variables. The structure of a bayesian network conveys important information about these relationships, making the graph itself informative.

In contrast, the structure of a neural network does not inherently convey information about variable dependencies. While bayesian networks explicitly represent relationships of independence and dependence between variables through conditional relations, neural network generally lack this direct interpretability. The intermediate nodes in a neural network are features discovered during training without any predefined meaning.

Furthermore, Bayesian Networks are typically simpler in terms of structure compared to Neural Networks. neural networks require the determination of hidden layers, topology, and various hyperparameters, making them more complex to design and optimize. Conversely, bayesian networks assume that input variables are independent, which, if incorrect, can affect the classifier's accuracy. However, neural network can handle correlations and dependencies between input variables through appropriate network structures ([Differences Between Bayesian Networks and Neural Networks, 2024](#)).

### *Advantages of bayesian networks for the U-cycle approach*

In the unified modeling approach of the U-cycle, bayesian networks offer several advantages over neural networks:

- **Data efficiency:** Bayesian networks are particularly useful for unsupervised learning when the available data is relatively limited. In contrast, neural networks are most effective when trained on large amounts of data, which may not always be available ([Bielza and Larrañaga, 2014](#); [Pollino and Henderson, 2010](#)).
- **Interpretability:** Bayesian approaches improve the interpretability of the prediction system. They provide clear explanations of the hypotheses and the decision-making process, whereas neural networks typically provide high accuracy precision in predictions without elucidating the underlying reasoning ([Uusitalo, 2007](#)).
- **Causal inference:** One of the most significant advantages of bayesian networks is their capability for causal inference. this feature is crucial for understanding the cause-and-effect relationships in the system, a fundamental aspect for both statistics and learning ([Bielza and Larrañaga, 2014](#); [Pollino and Henderson, 2010](#)).



It is important to note that bayesian networks and neural networks are not mutually exclusive. In fact, bayesian networks can be beneficial in designing neural networks with well-defined objective functions, potentially leveraging the strengths of both approaches. Given the specific requirements of the U-cycle methodology, bayesian networks are preferred over neural networks because of their efficiency with limited data, interpretability, and ability to make causal inferences.. These characteristics make bayesian networks a more appropriate choice for the reliable and robust modeling of complex systems within the U-cycle framework.

### **6.4 Case study: Application for U-cycle in a complex system**

This section presents a case study designed to illustrate the various steps of the conceptual approach to reliability assessment, focusing solely on qualitative modeling. Although it is based on a real industrial system, the case studied here is fictitious. Its purpose is to briefly explain the different steps of this conceptual approach to reliability assessment, based on solely qualitative modeling. The selected instrumentation will be based on the use of Bayesian Networks in order to show the way to holistic modeling within a unified methodological framework.

#### 6.4.1 System description

The system under study is a transportation system within the aeronautical sector, specifically focused on the increasing electrification of functions on board aircraft. This shift towards more electric aircraft represents a significant and irreversible evolution, that is expected to accelerate with future projects. The transition from hydraulic and pneumatic systems to electrical systems requires a significant increase in the power generation and distribution capabilities on board aircraft. Advances in research and lessons learned from recent programs, such as the Airbus A380 and Boeing 787 make it possible to envision a transformed onboard energy chain for the next generation of aircraft, predominantly centered with electrical systems at the center.

The concept of More Electric Aircraft (MEA) or Power Optimized Aircraft (POA) concept involves replacing multimodal circuits—mechanical, hydraulic, and pneumatic—with electrical circuits that control all aircraft functions, both on the ground and in flight. This transition includes the primary flight controls (pitch, roll, yaw) and secondary flight controls (slats, trailing flaps, ailerons, airbrakes, spoilers), as well as other critical functions such as air conditioning fans, fuel pumps, hydraulic pumps, and landing and thrust reverser systems.



## U-Cycle Approach Instrumentation

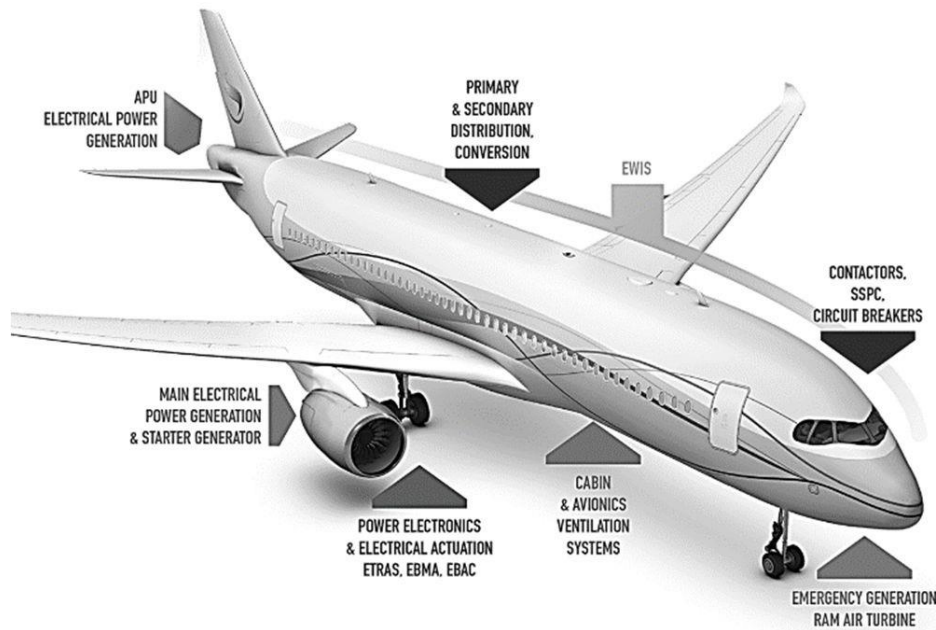

Figure 33. Electric Aircraft

The proliferation of electrical systems on board the new generation of aircraft necessitates an increase in the reliability of the devices that control or support these functions. This case study specifically addresses the use of the U-cycle approach to model the of the flight control system. The reliability of the flight control system is critical because of its role in ensuring on the aircraft during various phases of flight. The multiplication of electrical systems on board this new generation of aircraft makes it necessary to increase and improve the reliability of the devices that control them or support the corresponding functions. This case study will therefore deal with the use of the U-Cycle approach to model the function of the flight control flap actuation.

### 6.4.2 Deployment of the U-Cycle approach

#### 6.4.2.1 Structural view

In order to characterize the influence of the system on its constitutive elements and then to measure the impact of their respective reliability on the system, the architecture under study must be described according to a principle of structural and functional decomposition. The electrical power supply system linking the aircraft to its components is therefore shown in in Figure 34.

The electrical power system of an aircraft consists of several subsystems, each of which plays a critical role in providing reliable and continuous power supply during various phases of flight. The primary source of electrical power on board an aircraft is the engines. These engines generate mechanical energy, which is subsequently converted into electrical energy by generators. In the case of a twin-engine aircraft, two main generators (G1 and G2) are typically employed. In addition,, some aircraft are equipped with a third generator (G3) for increased redundancy and reliability.

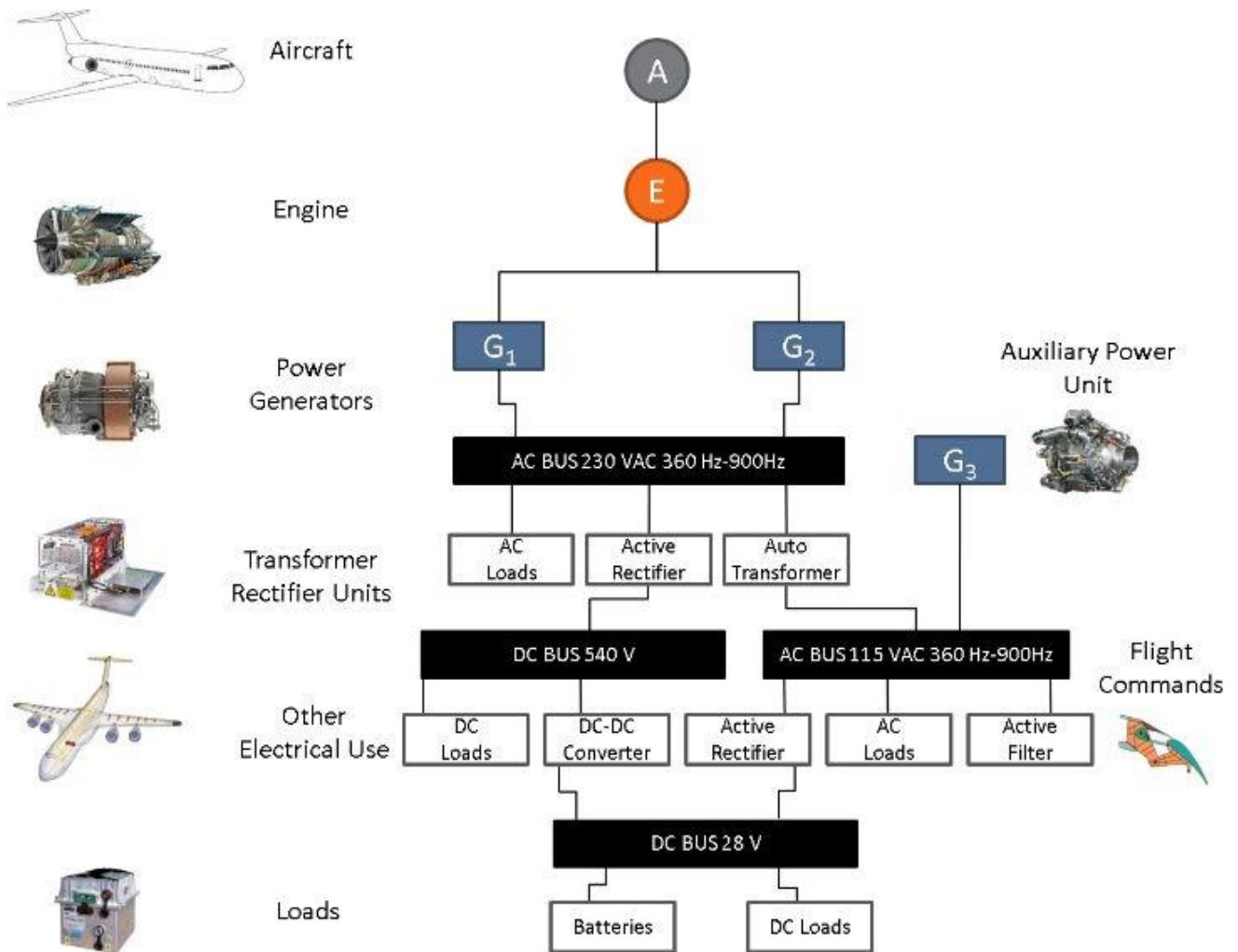

Figure 34. Case study structural breakdown

The Auxiliary Power Unit (APU) is another critical component of the aircraft's electrical power system. This small turbojet engine, usually located at the rear of the fuselage, runs on the same kerosene fuel as the main engines. The APU has several functions: it supplies the aircraft with electrical power, provides air conditioning when the main engines are not operating, and supplies the pneumatic energy required to start the main engines. Because of its small size, the APU can be started using a battery-powered electric starter. Once the main engines have started and taken over the air conditioning and power supply functions, the APU is typically shut down. The power generated by the main and auxiliary generators is then converted to supply various electrical systems on board the aircraft with the required voltages, commonly 115V AC or 28V DC. In addition, like most vehicles, aircraft are equipped with batteries, which serve as backup power sources. These batteries are typically lead-acid, Nickel Cadmium (Ni-Cd), or Lithium-Ion (Li-ion), provide power to critical systems in the certain of generator failure or during specific phases of flight where engine power is not available.

Other systems, not shown in the illustration also contribute to the aircraft's energy supply. Ground Power Units (GPUs) provide power when the aircraft is on the tarmac, ensuring that systems remain operational without relying on the onboard generators. In emergency situations, a Ram Air Turbine (RAT) can be used. This small wind turbine generates electricity from the airflow during flight, providing power to essential systems if the critical generators fail ([Gieras, 2013](#)).

Modeling the structural view of the aircraft electrical power system using Bayesian Networks involves integrating various components and their interactions into a unified framework. This modeling approach becomes particularly insightful when combined with the temporal view, which accounts for the dynamic operation and phase transitions of the system. The formalization of this combined view will be elaborated in the following section, where the temporal dynamics are superimposed on the structural framework, to provide a comprehensive reliability assessment of the electrical power supply system. By utilizing Bayesian Networks, the structural dependencies and failure probabilities of the electrical subsystems can be effectively analyzed, offering a probabilistic understanding of the system's reliability and identifying potential points of failure. This holistic modeling approach is essential for the development of robust and reliable aircraft systems capable of withstanding various operational stresses and ensuring continuous power supply under all conditions.

### 6.4.2.2 Temporal view

The temporal view introduces the concept of the dynamic evolution of the system in relation to its usage profile, which consists of different, missions distributed in time and space. This view characterizes the consequences in terms of the demands placed on the various subsystems according to the phases induced by these different missions. For a given mission, such as a flight from point A to point B, the phases of aircraft use are as follows ([Tiassou \*et al.\*, 2012](#)):

- Standing (S): This phase occurs before to pushback or taxi, or after arrival, while the aircraft is stationary at the gate, ramp, or parking area.
- Taxi (X): This phase occurs when, the aircraft is moving on the surface of an airfield under its own power, excluding take-off and landing.
- Take-off (O): This phase begins with from the application of take-off power until reaching the first prescribed power is reached.
- En-route (E): This phase includes the period from the completion of the initial climb through cruising altitude and the completion of controlled descent to the Initial Approach Fix (IAF).
- Approach (A): This phase extends from the outer marker to the point of transition from a nose-low to a nose-high attitude just before the flare above the runway.
- Landing (L): This phase includes the transition from a nose-low to a nose-up attitude just before landing (flare), through touchdown, and until airplane leaves the runway.

At the structural level 2, which includes the engines, the phases can be associated with specific power levels required during each phase of flight (Grabowski, Czyż and Porzak, 2018). For example, it is observed that the power delivered by the engine is 10% of its maximum power during the Taxi phase, 95% during the Take-off and climb phases, 64% during the cruise phase, and 16% during the descent and landing phases.

The phases of stage 3, corresponding to the generators, are closely related to those of stage level 2. In an all-electric aircraft, the two variable frequency generators (VFG 1 and VFG 2) are directly coupled to the high-pressure level of the engine. This direct coupling eliminates the need for a mechanical speed control system, thereby reducing the size and weight of the generators. As a result, the frequency of the generated currents varies between approximately 400 and 800 Hz due to changes in turbine speed. By knowing the torque (C) of the engine, which is a function of the thrust required according to the flight phase, and the power consumed, it is possible to deduce the speed and thus the different frequencies can be deduced. Discretization of this frequency variation range allows for the identification of the different operating phases.

During the production mode, the converter rectifies the input electrical power generated from a variable frequency voltage to provide a stable bipolar DC power supply network. The operating phases of level 4, associated with the converter, depend on both the frequency of the power generated and the power required by the different types of power consumption. The electrical functions that must or can be performed include lighting (F1), air management system (F2), pressurization (F3), defrost (F4), engine start (F5), flight controls (F6), landing gear operation (F7), thrust reversers (F8), and the electric taxiing system (F9). The converter's role adapts to the specific requirements of these systems, acting as a transformer, rectifier, chopper, or inverter depending on the nature of the task. The phases of the converter are thus dictated by the function it needs to perform. For example, the AC/AC converter allows the conversion of a 230V, 360Hz-900Hz alternating current to a 115V, 360Hz-900Hz alternating current. This conversion process is critical for powering electro hydrostatic actuators used to control aircraft flaps (as shown in Figure 35).

The conversion process involves three main stages:

1. Passive rectifier function (Phase R): This phase involves ACtoDC conversion, where the alternating current (230V AC, 360Hz-900Hz) is rectified to a direct current (230V DC).
2. Dissipative Chopper Function (Phase H): This phase performs DC to DC conversion, adjusting the direct current from 230V DC to 270V DC.
3. Inverter Function (Phase O): This last phase involves DC to AC conversion, where the direct current (270V DC) is inverted to an alternating current (115V AC, 360Hz-900Hz).

By understanding the specific requirements and operating phases of the converter, it is possible to optimize the reliability and efficiency of the electrical power supply system on the aircraft. This comprehensive analysis of the temporal view, combined with the structural view, provides for a detailed understanding of the dynamic interactions and demands on the aircraft subsystems, to ensure robust and reliable operation throughout all phases of flight.

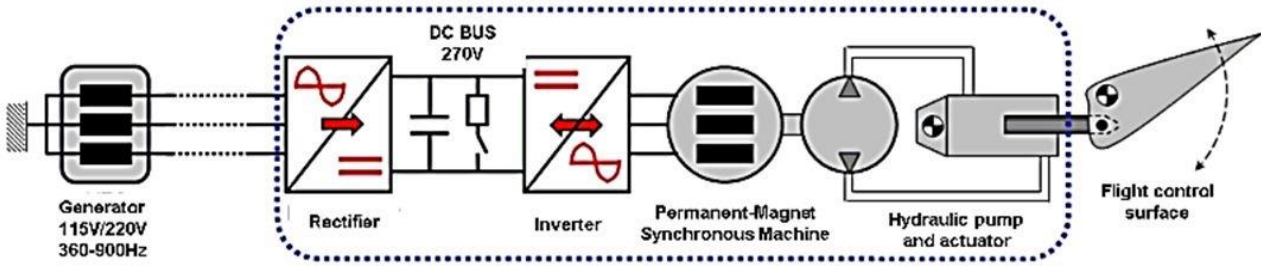

Figure 35. Control aircraft flaps electro hydrostatic actuator

Finally, level 5 concerns the power electronics within the converter (Figure. 36) (Lim *et al.*, 2018). The operating phases of each IGBT-G module correspond to the respective loads of the rectifier, chopper and inverter integrated into the converter. All of the above information can then be compiled in the form of a Bayesian network of structural and temporal views. The framed blocks correspond to the different phases of the different subsystems supporting the actuator power supply function. For the sake of visual simplify, when the connection between the variables associated with two blocks is complete, we will limit ourselves to connecting the blocks and not the variables.

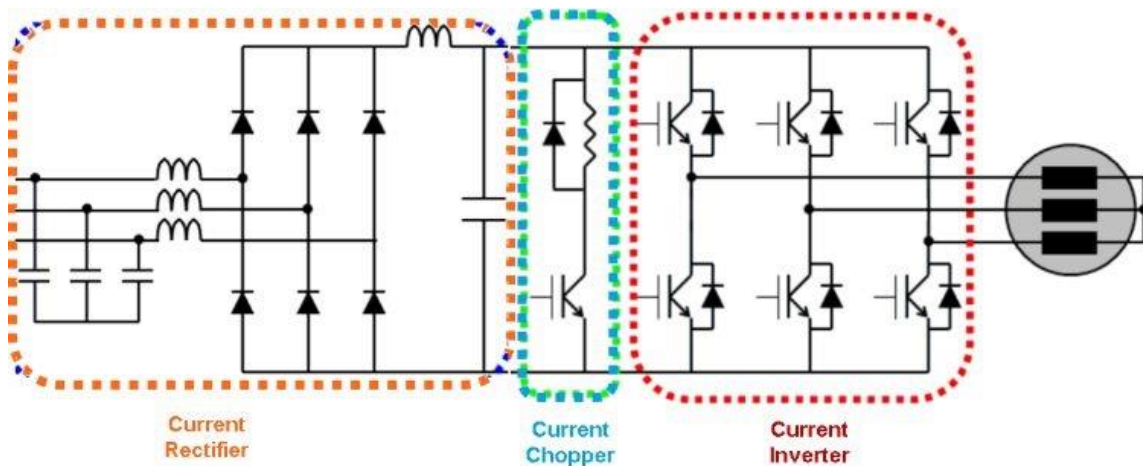

Figure 36. Converter architecture

The framed blocks correspond to the different phases of the different subsystems supporting the actuator power supply function. For the sake of visual simplicity, when the connection between the variables associated with two blocks is complete, we will limit ourselves to connecting the blocks and not the variables.

Temporal aspects can be incorporated into the Bayesian approach by using dynamic nodes. Dynamic Bayesian Networks (DBNs) extend traditional Bayesian networks to capture the temporal or spatial evolution of random variables. In these networks, dynamic variables are represented by dotted circles, indicating the influence of a variable at time  $t_t$  on its state at time  $t_{t+1}$  (as shown in Figure 38) (Chen *et al.*, 2014; Kosgodagan-Dalla Torre *et al.*, 2017).



## U-Cycle Approach Instrumentation

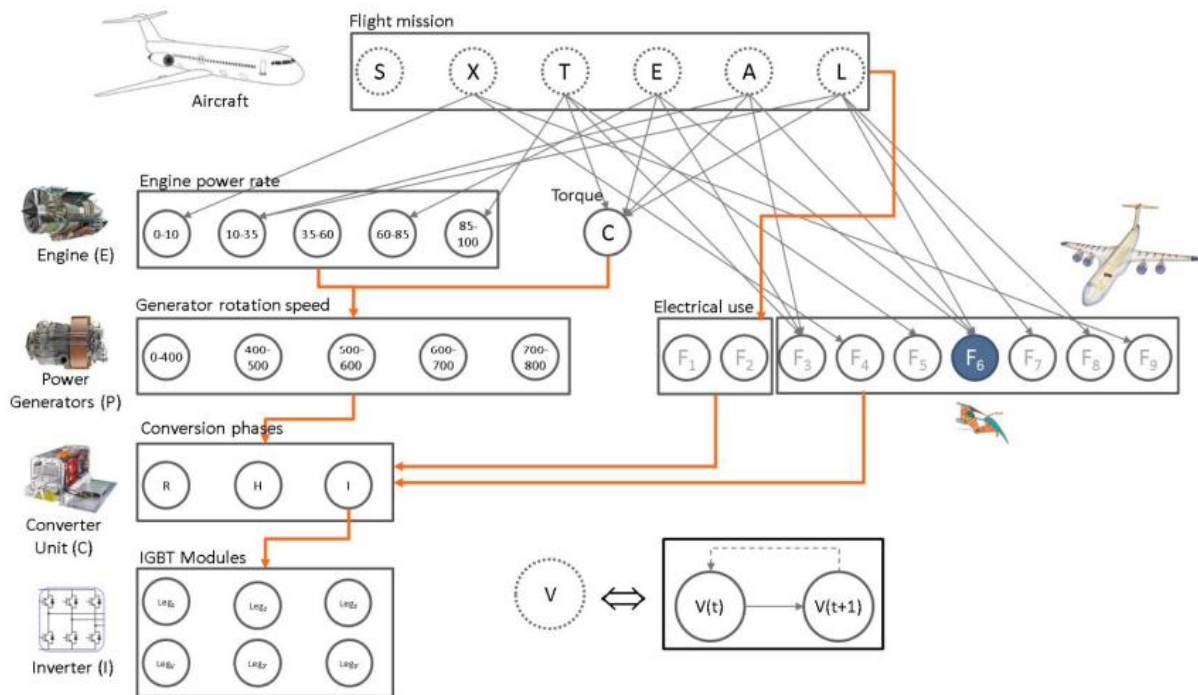

Figure 37. Bayesian network representation for structural and temporal view

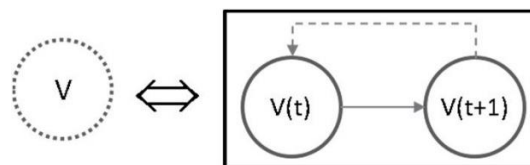

Figure 38. Bayesian network dynamic node

This approach can be useful for determining a chronology but is not mandatory since the knowledge of the duration of stay in a given state (represented here for example, by a probability characterizing the proportion of time spent in loading, taxing, take off, cruise, approach or landing phases) can be sufficient for the analysis.

### 6.4.2.3 Physical View

The state variables, that describe behavior of the system in response to the demands imposed by the mission profile of its various components. In the Bayesian model corresponding to this view, the physical processes are not explicitly shown to simplify the graphical representation. Instead, only the significant state variables are considered, which provide essential information about the thermal ( $\theta_i$ ), mechanical ( $\sigma_i$ ), electrical ( $\varepsilon_i$ ), magnetic ( $\Omega_i$ ), and hygrometric ( $\Psi_i$ ) stresses affecting the system, where (i) is the index of the structural element under consideration.

## U-Cycle Approach Instrumentation

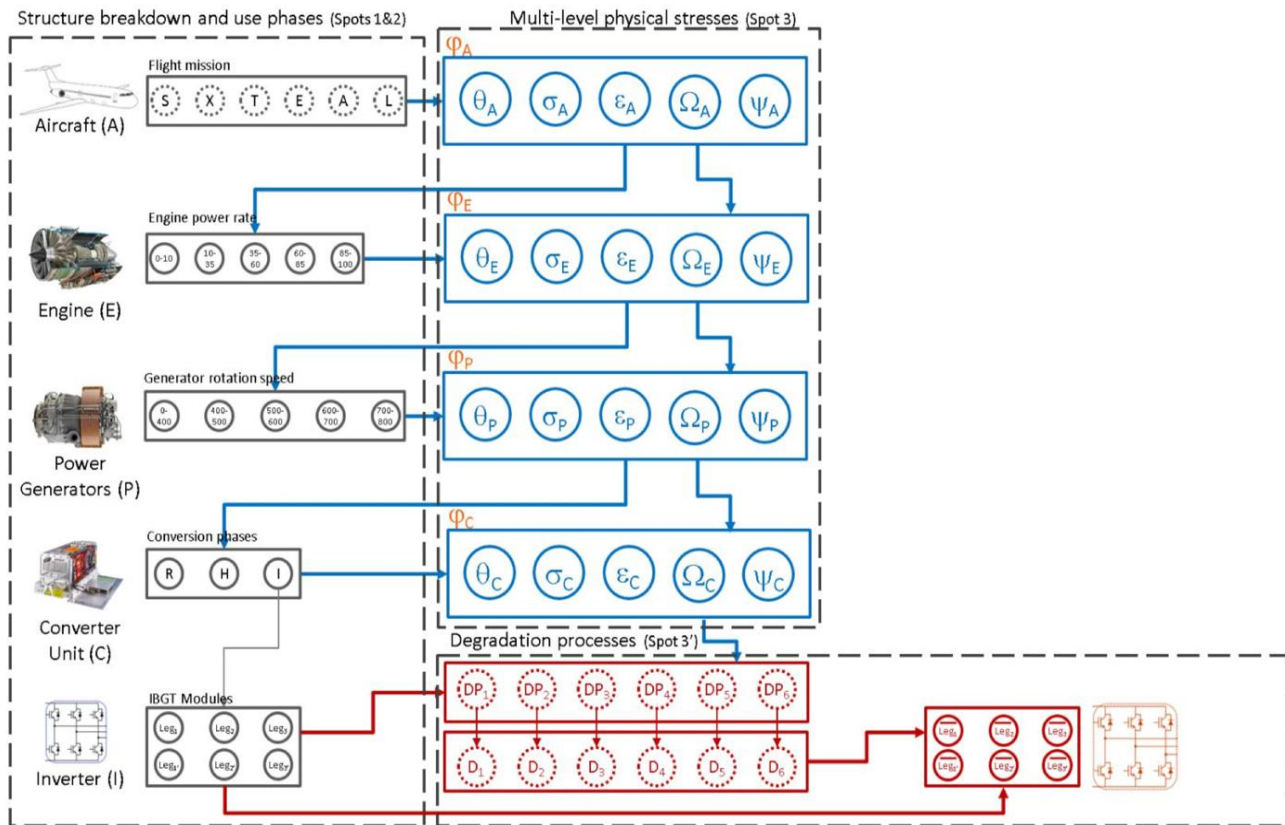

*Figure 39. Bayesian network representing the structural, temporal and physical views*

The first step is to understand the stresses to which the components are subjected. It is necessary to identify the mechanisms of slow or catalytic degradation that are likely to cause material damage and push the system towards failure. These degradation processes (DP<sub>i</sub>) occur at the level of the elementary components, focusing here on the IGBT modules of the converter. The IGBT modules be subjected to various degradation mechanisms, either of internal origin (such as malformation of the gate oxide, impurities in the silicon crystals, packaging defects, or problems with the silicone gel) or external origin (such as stresses applied to the component during its normal operation, including voltage, temperature, vibration, and shock). Major degradation processes include:

1. Bond wire detachment (DP1): This occurs in the active part of the IGBT modules, particularly at the interface with the chips. The bond wires, which carry high currents and are subject to intense thermal cycling, are designed for specific current density distribution values and dissipation powers. Exceeding these limits can result in failure. The degradation indicator for the bond wires is the VCE voltage (Collector-Emitter) of the chips.
2. Solder Fatigue (DP2): The substrate solder is susceptible to fatigue phenomena. Temperature variations cause a shearing effect that eventually delaminates the solder, starting at the edges. This reduces the exchange area between the chip and the solder, increasing the thermal resistance of the solder.

3. Reverse Bias Safe Operating Area (RBSOA) (DP3): The RBSOA is a set of special operating conditions defined by the IGBT supplier, that represents a safe area where the IGBT can operate without damage. Operation outside of this area can lead to electrical or thermal phenomena that cause immediate component failure.

4. Bonding wire corrosion (DP4): In bond wires, aluminum in contact with oxygen from the atmosphere undergoes passivation, forming a layer of aluminum oxide. This layer can become a soluble aluminum hydroxide in the presence of water, resulting in aluminum corrosion when exposed to an electrolyte.

5. Electrochemical migration (DP5): This degradation mode involves cathode corrosion, metal ion migration, and metal deposition on the anode. Electrochemical migration results from corrosion caused by moisture, leading to the formation of dendrites that degrade the insulating properties between the conductors, eventually causing chip failure.

6. Other Mechanisms (DP6): Other, less common processes can also damage IGBT modules, including corrosion of the chip termination, cosmic radiation, deformation of metallization on the chip surface, fatigue of power connector solders, partial discharge phenomena in insulators, aging of gate oxides, dielectric breakdown of the gel, or cracking of the chip, substrate, or package. These degradation mechanisms can cause damage that can be quantified in terms of cumulative fatigue, plastic deformation, degradation, parameter drift, or device failure. Once a component no longer remains in its nominal state, it is considered to have failed.

The physical processes associated with the functional (point 3) and dysfunctional (point 3') views are represented as a Bayesian network. This network initiates the ascending process in the dysfunctional axis of the U-cycle. The characterization of the degradation modes (DPi) can include dynamic variables that lead to the temporal evolution of the damage (D) incurred by the equipment. Component failure is observed when the cumulative defect from degradation mechanisms exceeds an acceptable limit or occurs randomly due to a quality defect.

### ***Component Failure: A Physical Process Modeling Example***

To clarify failure mechanisms and reliability analysis, Figure 40 illustrates the process of component failure modeling, showcasing the sequential degradation of an electronic component.

#### **Step 1: Mission Profile, Inferred Constraints, and Side Effects**

Modeling starts by defining the component's mission profile, detailing the phases of operation, such as takeoff, cruise, and landing in an aircraft system. From this, constraints such as electrical, mechanical, thermal, and pressure factors are inferred. These constraints cause side effects, including changes in current density, temperature, and stress, which directly impact the component's performance and lifespan.

- **Mission Profile:** Describes operational phases under different conditions.
- **Inferred Constraints:** Includes electrical, magnetic, mechanical, thermal, hygrometric, and pressure-related factors.
- **Side Effects:** These constraints lead to changes in current density, temperature, and mechanical stress.



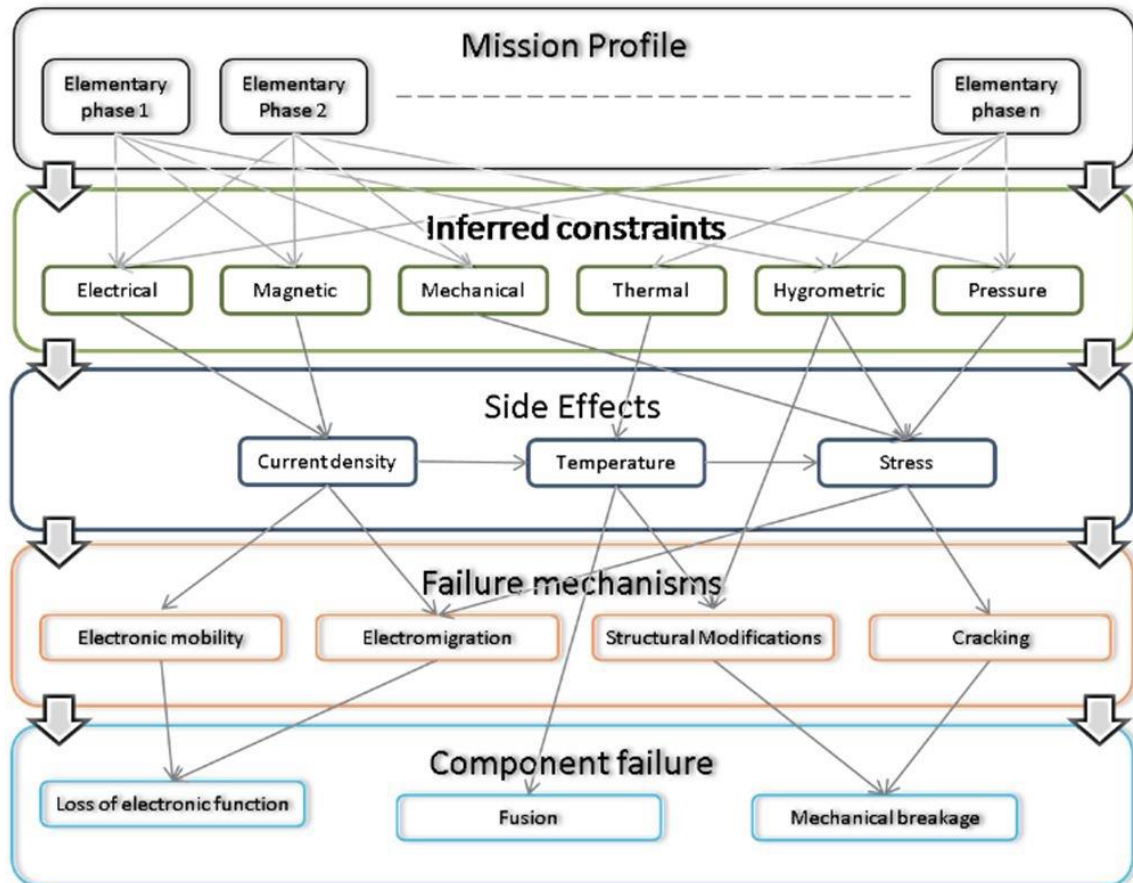

Figure 40. Example of component failure physical process modelling

### Step 2: Failure Mechanisms

The side effects give rise to failure mechanisms such as electromigration, structural changes, and cracking, which degrade the component's functionality.

- **Electromigration:** High current density causes metal ions to shift, breaking conductive pathways.
- **Structural Modifications:** Stress-induced changes in material integrity weaken functionality.
- **Cracking:** Mechanical stress or thermal cycling creates fissures, leading to failure.

### Step 3: Component Failure

As failure mechanisms evolve, they result in component failure, such as loss of electronic function, mechanical breakage, or fusion. These failures reflect the culmination of the operational and environmental stresses on the component.

- **Loss of Function:** Caused by disruptions in conductive pathways.
- **Mechanical Breakage:** Occurs when stress or cracks compromise physical integrity.
- **Fusion:** Excessive current or heat leads to component overheating and permanent damage.

This stepwise approach provides a comprehensive view of how failure mechanisms arise from operational constraints, guiding design improvements and maintenance strategies.

6.4.2.4 Logical view

The logical view allows us to analyse the structure of the system by evaluating how different components affect its overall reliability. This approach considers material or functional redundancies that may be built into the system, particularly for essential functions related to safety and security.

**Redundancy in the more electric aircraft (MEA):**

In the context of more electric aircraft, a redundant architecture plays a critical role in ensuring that the system can tolerate the loss of critical components or functions, such as flight controls. As shown in Figure 41, the mechanical power generated by the two variable frequency generators (VFG1 and VFG2) supports two separate hydraulic circuits (H1 and H2) and two electrical circuits (E1 and E2). These circuits work in tandem to power all actuators, including the electro-hydraulic actuators (EHA) used in the flight controls. This dual-system architecture greatly increases the system's fault tolerance and reliability.

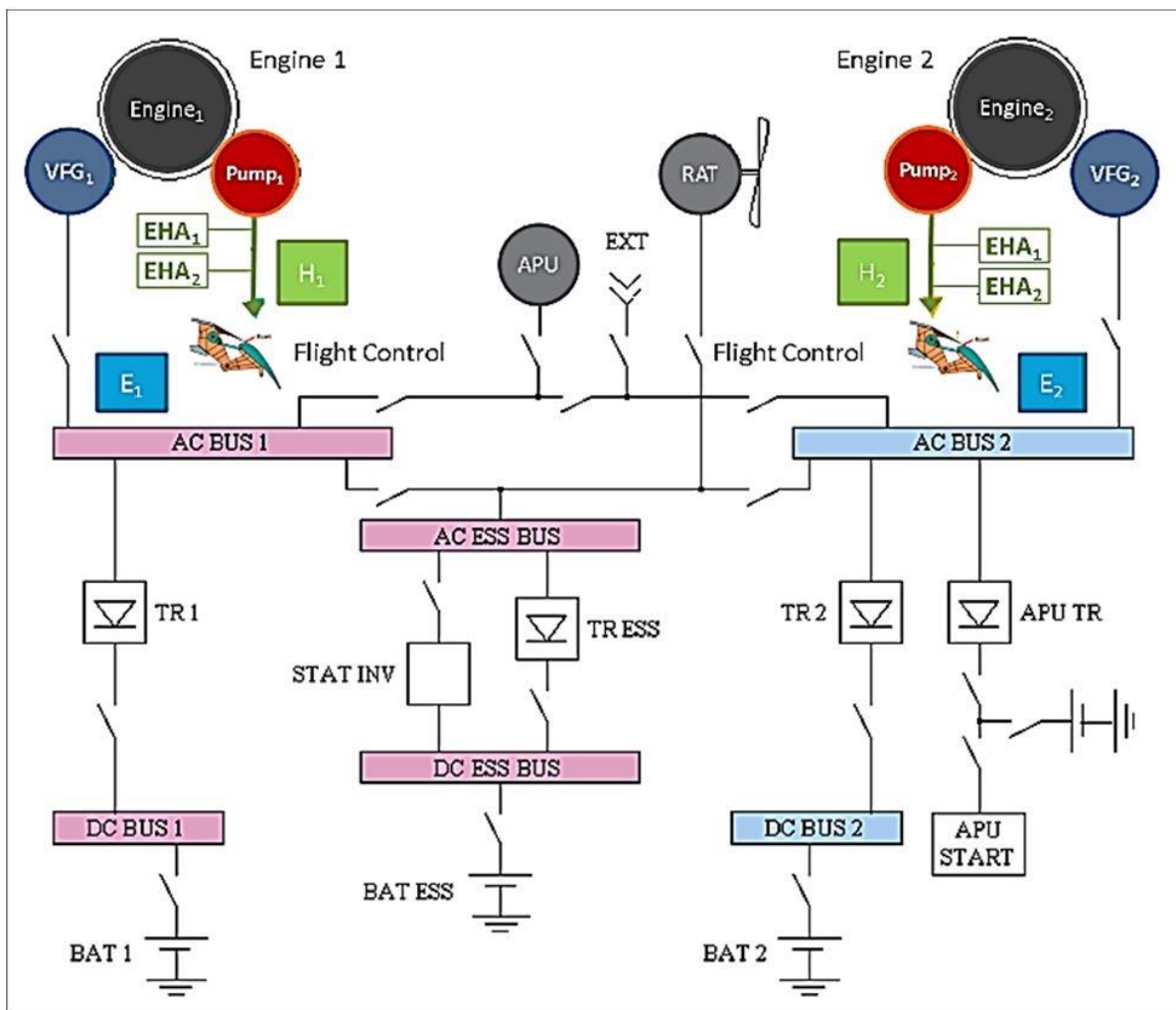

Figure 41. Simplified architecture of the electrical network of a 300- passenger "2H2E" aircraft (adapted from (Langlois et al., 2006))

**Engine redundancy:**

In the event of engine failure, redundancy is provided by the Auxiliary Power Unit (APU) or the Ram Air Turbine (RAT). The RAT, a wind turbine located in either the fuselage or one of the wings, automatically deploys when a loss of power is detected. This mechanism ensures that critical systems remain operational, even in the absence of primary engine power.

**Primary flight controls:**

The movement of each flight control surface is typically driven by one to three hydraulic actuators (EHA). When multiple EHAs are installed on a single surface, they typically operate in passive redundancy. However, this redundancy can become active to meet specific operational requirements, providing flexibility and increasing reliability.

**Inverter redundancy:**

On the power conversion side, redundancy can be built to the inverter's switching cells. Various configurations are possible such as 4-leg, 6-leg, or backup leg inverters. Figure 42 shown the parallel-leg inverter technology, which offers the highest reliability among the available configurations. This technology ensures continuous operation by switching from the leading leg to a backup leg, when necessary, with the reliability of the transition represented by the parameter  $\lambda_s$ .

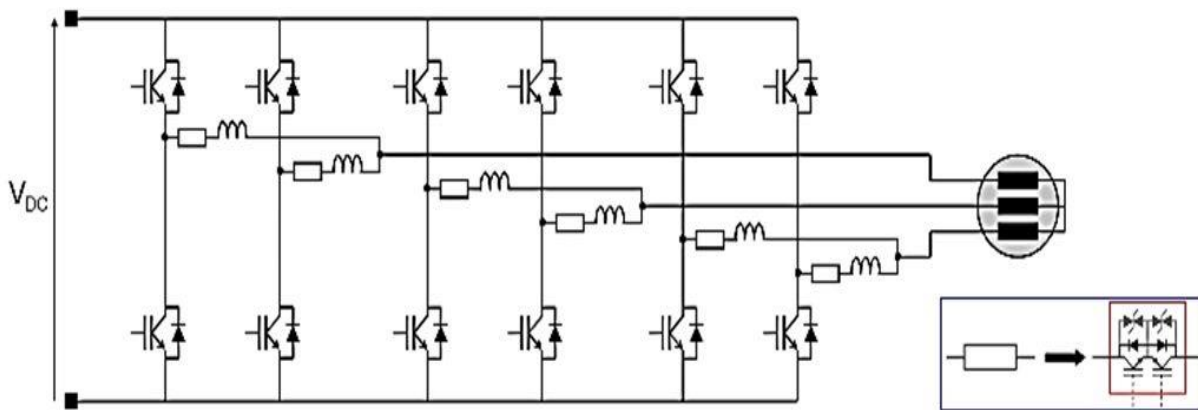

Figure 42. Three-phase inverter with parallelised cells two by two with decoupling inductors and insulation switches

All these redundancies contribute to a system configuration whose reliability behaviour is shown in the reliability block diagram shown in Figure 43. In this diagram,  $\lambda_{Leg}$  represents the failure rate of an inverter leg, while  $\lambda_s$  represents the reliability of switching from the active leg to the backup leg. This diagram provides a clear representation of the logical view, characterizing the upward movement in the U-cycle and highlighting the robustness of the overall system through strategic redundancy at different structural levels. (Bouhamed *et al.*, 2015).

## U-Cycle Approach Instrumentation

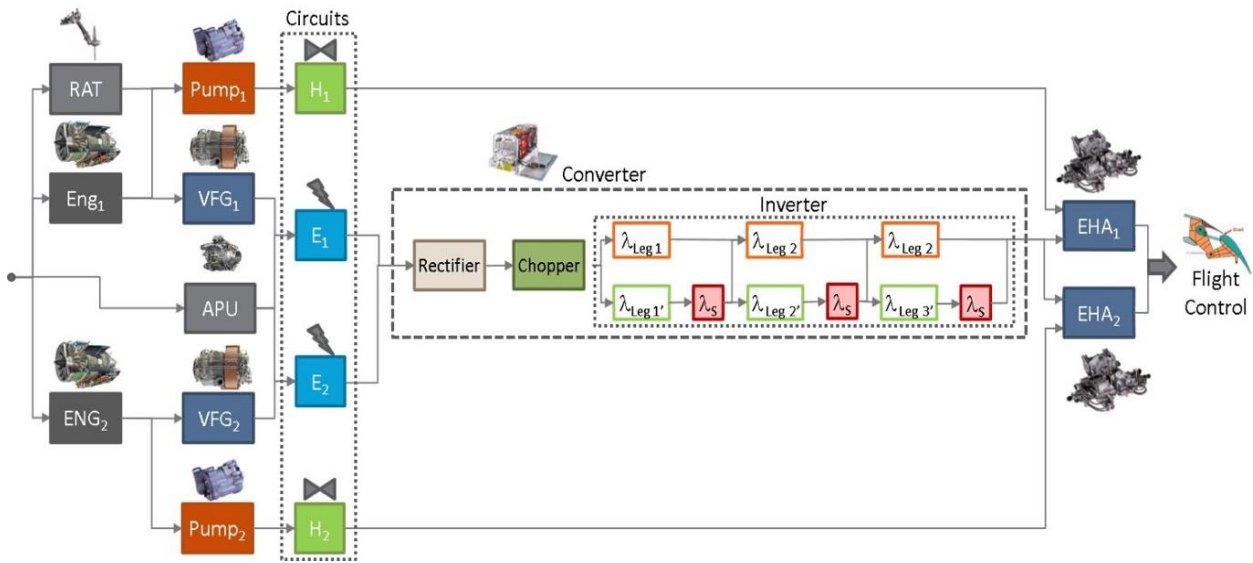

Figure 43. Block reliability diagram of function F6

The multiplication of the safety systems related to the duplication of the IGBT legs, the diversity of the sources of electric or hydraulic power generation, the duplication of the aircraft engines or the use of auxiliary elements, makes it possible to determine the reliability of the function supporting the actuation of the flight control flap ( $R_{EHA-PS}$ ). This information is summarised in the form of a Bayesian network in the descriptive framework of Spot 4 shown in Figure 44.

## U-Cycle Approach Instrumentation

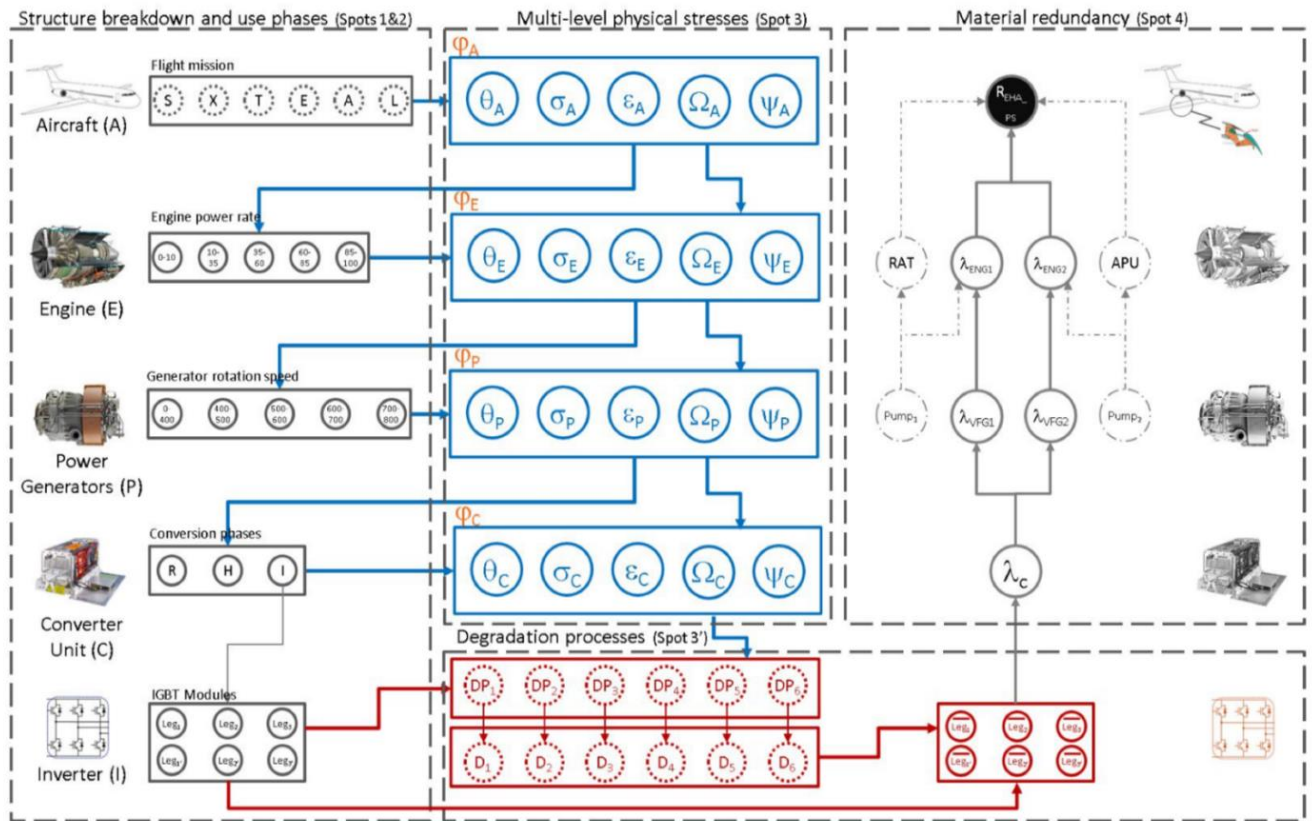

Figure 44. Bayesian network representing the structural, temporal, physical and logical views

Each node of this logical view expresses the probability that the function required by the structural element under consideration to ensure the control of the flaps will be performed. The auxiliary elements RAT, APU and the two pumps (in hybrid dotted lines) have been added because they also intervene in the function. Although the same U-cycle approach could be used to characterize their reliability, they have not been discussed in this thesis from this point of view. We have assumed that their failure rate was known (given, for example, by the equipment supplier) and can be included directly into the model.

## 6.5: Future Perspectives & Research Direction

While this thesis presents a comprehensive framework for multi-scale reliability assessment, further research is necessary to enhance its applicability and automation. The integration of AI-driven reliability modelling and Bayesian Networks provides a strong foundation, but future advancements could focus on real-time implementation and predictive analytics.

A promising direction is the development of an IT-based platform that integrates real-time data streams with multi-scale reliability models, allowing for dynamic, adaptive failure prediction. The incorporation of digital twins could enable a self-learning reliability framework, where models evolve based on observed system performance, thereby bridging the gap between theoretical modelling and industrial application.

Furthermore, improving the computational efficiency of multi-scale reliability modelling will be essential for large-scale systems. Future studies could explore hybrid modelling approaches, leveraging physics-informed machine learning to reduce computational complexity while maintaining high accuracy.

The long-term vision for this research is to create a fully automated reliability assessment tool, capable of predicting failures, recommending maintenance actions, and continuously refining system models based on operational feedback. These advancements will ensure that the U-cycle approach remains at the forefront of reliability engineering, offering scalable, intelligent solutions for complex system assessment.

# **Conclusion and perspectives**



### Conclusion

In this thesis, we explored the integration of Bayesian network technology into the U-cycle framework for modeling the reliability and dependability of complex systems. The U-cycle approach, which systematically examines systems at both macroscopic and microscopic levels, has been enhanced by the application of Bayesian methods, specifically Dynamic Bayesian Networks (DBNs). This combination provides a robust framework for managing the inherent uncertainties and interdependencies that characterize modern complex systems, such as those found in aerospace applications.

The illustrative application focused on the reliability assessment of an aircraft engine across its mission profile, consisting of takeoff, cruise, and landing phases. Using a dynamic Bayesian Network, we were able to model the probabilistic relationships between different mission phases and the engine's state transitions. This approach provided a more nuanced understanding of how different conditions, including weather and operational stresses, affect engine performance over time.

We then detailed the parameters of the simplified model, using expert knowledge and existing standards were used to estimate the conditional probabilities in the absence of specific empirical data. These initial estimates served as a fundamental step in constructing a representative model of the system's behavior. The results from the simulation indicated that the engine's condition remained relatively stable during the cruise phase but showed significant degradation during the landing phase due to cumulative loads. This highlighted the importance of thorough assessments and potential maintenance actions, especially after demanding phases like landing. The ability of the Bayesian model to adapt to more accurate data as it becomes available was also highlighted, demonstrating the flexibility and scalability of the approach. This adaptability is critical for accurately modeling complex systems where variability and uncertainty are constant challenges.

In summary, the integration of Bayesian Networks into the U-cycle framework not only improves the reliability analysis of complex systems but also provides a practical tool for decision making in real-world scenarios. The approach demonstrated in this thesis is not only applicable to aerospace systems but can be generalized to other complex engineering systems where reliability and safety are critical. Future work should focus on refining these models with empirical data and exploring their applicability in other domains, further validating the effectiveness of Bayesian technology in complex system analysis.

### Critical analysis and prospects

The approach considered here within a unifying framework, primarily based on Bayesian Networks (BNs), seems theoretically adequate. However, the holistic modeling of a system that integrates all structural, temporal, physical, and logical views prove to be very challenging. There are two main reasons for this difficulty.



## Conclusion and Perspectives

The first reason is the complexity of the model. The model must capture all the information about its various components, their operating phases, and their physical behavior. For systems with complex architectures consisting of many interconnected components, the multiplication and nesting of views can become unmanageable. As the size of the system and the number of component relationships increase, BNs face limitations in modeling capacity, particularly concerning visual interpretation, parameter determination, and propagation of local observations. To mitigate this complexity, we propose to exploit the ability of BNs to partition the information system into sub-parts, processing each part's learning structure separately before reassembling them (Bouhamed *et al.*, 2015). This partitioning can be done by:

- Limit the number of structural levels considered simultaneously.
- Separate the functional and dysfunctional views associated with the proper functioning or degradation processes of the elementary components.
- Separate separately the logical view that characterizes the reliability performance of the system by fusing elementary information.

When modules are repeated and exhibit structural or behavioral homogeneity, Bayesian Network techniques based on the "Object-Oriented" paradigm (OOBN) may be employed (Quan *et al.*, 2015; Liu, Pérès and Tchangani, 2016; Liu, Tchangani and Pérès, 2016)

The second major difficulty relates to the accessibility of input data. Classically, data for Bayesian Networks come from four potential sources. The most appropriate source is within a global artificial intelligence framework, based on feedback from sensors or statistical records used in the design phase (behavioral prognosis) or in real-time during the system's operational phase (fault diagnosis and prognosis of observed abnormalities). In the absence of such data, physical knowledge and laws governing system behavior can be used to recreate datasets artificially. However, this solution is limited by the shortcomings of analytical approaches, which are hampered by overly restrictive hypotheses. A third method is to construct data from the design and use of test beds that, reproduce the conditions under which the system operates and establish relationships between variables at functional and dysfunctional levels. The theoretical approach then translates the test results into acceleration factors to define the failure laws governing the subsystems. The fourth method is expertise, which can identify specific parameters but often remains questionable.

Given these limitations, a potential perspective for future work involves an alternative approach. If Bayesian networks cannot be supplied with data, the goal is to create a qualitative model to identify the information needed for quantitative processing. If Bayesian models and big data are considered a credible alternative to current reliability estimates, it is necessary to collect information at the source. This requires tracking the values of key variables at selected times and quantifying their parent variables in the causal graph. This approach relies on the implementation of an integrated sensor system within transport systems (aircraft, trains, trucks, etc.). The type, number, and positioning of sensors must be carefully studied. The instrumentation of transportation systems in service will allow for recording electrical, mechanical, kinetic, or environmental data at fixed or variable intervals over defined periods of time. The principles of fusion of the collected information (heterogeneous or located at different levels of the system hierarchy) must also be defined.<sup>i</sup>

## Conclusion and Perspectives

# **Bibliography**

## Bibliography

- Abbas, M., & Vachtsevanos, G. J. (2009). *A System-Level Approach to Fault Progression Analysis in Complex Engineering Systems*.
- Abdulgalil, M. A., Alharbi, H. S., Khalid, M., & Almuahini, M. M. (2018). Reliability Assessment of Microgrids with Multiple Distributed Generations and Hybrid Energy Storage. *2018 IEEE 27th International Symposium on Industrial Electronics (ISIE)*, 868–873. <https://doi.org/10.1109/ISIE.2018.8433614>
- Adumene, S., Khan, F., Adedigba, S., & Zendejboudi, S. (2021). Offshore system safety and reliability considering microbial influenced multiple failure modes and their interdependencies. *Reliability Engineering & System Safety*, 215, 107862. <https://doi.org/10.1016/j.ress.2021.107862>
- Aeologic (2023). "Top Emerging Technology Trends in Aviation Industry." [Aeologic Blog](#).
- Aghaei, M., Fairbrother, A., Gok, A., Ahmad, S., Kazim, S., Lobato, K., Oreski, G., Reinders, A., Schmitz, J., Theelen, M., Yilmaz, P., & Kettle, J. (2022). Review of degradation and failure phenomena in photovoltaic modules. *Renewable and Sustainable Energy Reviews*, 159, 112160. <https://doi.org/10.1016/j.rser.2022.112160>
- Akhtar, I., & Kirmani, S. (2022). An Application of Fuzzy Fault Tree Analysis for Reliability Evaluation of Wind Energy System. *IETE Journal of Research*, 68(6), 4265–4278. <https://doi.org/10.1080/03772063.2020.1791741>
- Alber, M., Buganza Tepole, A., Cannon, W. R., De, S., Dura-Bernal, S., Garikipati, K., Karniadakis, G., Lytton, W. W., Perdikaris, P., Petzold, L., & Kuhl, E. (2019). Integrating machine learning and multiscale modelling—Perspectives, challenges, and opportunities in the biological, biomedical, and behavioural sciences. *Npj Digital Medicine*, 2(1), Article 1. <https://doi.org/10.1038/s41746-019-0193-y>
- Alber, M., Buganza Tepole, A., Cannon, W. R., De, S., Dura-Bernal, S., Garikipati, K., Karniadakis, G., Lytton, W. W., Perdikaris, P., Petzold, L., & Kuhl, E. (2019). Integrating machine learning and multiscale modeling—Perspectives, challenges, and opportunities in the biological, biomedical, and behavioral sciences. *Npj Digital Medicine*, 2(1), 115. <https://doi.org/10.1038/s41746-019-0193-y>
- Alexandrescu, D. (2023, December 12). *Mission Profile Analytics For The Automotive Industry*. Semiconductor Engineering. <https://semiengineering.com/mission-profiles-analytics-for-the-automotive-industry/>
- Al-Haik, M., & Perez, F. (2009). Analysis of Elastic Stress Wave Propagation through a Complex Composite Structure. *International Journal of Theoretical and Applied Multiscale Mechanics*, 1, 164. <https://doi.org/10.1504/IJTAMM.2009.029216>
- Amprius Technologies (2023). "The Future of Technology in Aircraft Safety." [Amprius Technologies](#).

## Bibliography

- Shevchenko, N. An Introduction to Model-Based Systems Engineering (MBSE), 2020. URL <https://bit.ly/3M3qtaS>.
- Ariyo, O.O. & Eckert, Claudia & Clarkson, P.. (2008). Hierarchical decompositions for complex product representation. 737-744.
- Baspnar, B., Balakrishnan, H., & Koyuncu, E. (2020). Optimization-Based Autonomous Air Traffic Control for Airspace Capacity Improvement. *IEEE Transactions on Aerospace and Electronic Systems*, 56(6), 4814–4830. <https://doi.org/10.1109/TAES.2020.3003106>
- Ben Hassen, W., Auzanneau, F., Incarbone, L., Pérès, F., & Tchangani, A. P. (2013). On-line diagnosis using Orthogonal Multi-Tone Time Domain Reflectometry in a lossy cable. *10th International Multi-Conferences on Systems, Signals & Devices 2013 (SSD13)*, 1–6. <https://doi.org/10.1109/SSD.2013.6564144>
- Bielza, C., & Larrañaga, P. (2014). Bayesian networks in neuroscience: A survey. *Frontiers in Computational Neuroscience*, 8. <https://doi.org/10.3389/fncom.2014.00131>
- Blanco, J. A., & Lo, Y.-H. (2023). Latest Trends in Modelling Forest Ecosystems: New Approaches or Just New Methods? *Current Forestry Reports*, 9(4), 219–229. <https://doi.org/10.1007/s40725-023-00189-y>
- Bobbio, A., Portinale, L., Minichino, M., & Ciancamerla, E. (2001). "Improving the analysis of dependable systems by mapping fault trees into Bayesian networks." *Reliability Engineering & System Safety*, 71(3), 249-260.
- Bollen, K. A., & Pearl, J. (2013). Eight Myths About Causality and Structural Equation Models. In S. L. Morgan (Ed.), *Handbook of Causal Analysis for Social Research* (pp. 301–328). Springer Netherlands. [https://doi.org/10.1007/978-94-007-6094-3\\_15](https://doi.org/10.1007/978-94-007-6094-3_15)
- Boryczko, K., Szpak, D., Żywiec, J., & Tchorzewska-Cieślak, B. (2022). The Use of a Fault Tree Analysis (FTA) in the Operator Reliability Assessment of the Critical Infrastructure on the Example of Water Supply System. *Energies*, 15(12), 4416. <https://doi.org/10.3390/en15124416>
- Bouhamed, H., Masmoudi, A., Lecroq, T., & Rebaï, A. (2015). Structure space of Bayesian networks is dramatically reduced by subdividing it in sub-networks. *Journal of Computational and Applied Mathematics*, 287, 48–62. <https://doi.org/10.1016/j.cam.2015.02.055>
- Bouhamed, H., Masmoudi, A., Lecroq, T., & Rebaï, A. (2015). Structure space of Bayesian networks is dramatically reduced by subdividing it in sub-networks. *Journal of Computational and Applied Mathematics*, 287, 48–62. <https://doi.org/10.1016/j.cam.2015.02.055>
- Budhavarapu, P. S. S., Chaturvedi, S., Garg, D., & Chakravorty, S. (2014). Multi-Phase System Reliability Analysis using Excel. *International Journal of Performability Engineering*. <https://www.semanticscholar.org/paper/Multi-Phase-System-Reliability-Analysis-using-Excel-Budhavarapu-Chaturvedi/03bfca5da783584cfc8b3e8d72696d10fbab4611>
- Cabrera, A. A. A., Komoto, H., van Beek, T. J., & Tomiyama, T. (2014). Architecture-Centric Design Approach for Multidisciplinary Product Development. In T. W. Simpson, J. (Roger) Jiao, Z. Siddique, & K. Hölttä-Otto (Eds.), *Advances in Product Family and*

## Bibliography

- Product Platform Design: Methods & Applications* (pp. 419–447). Springer.  
[https://doi.org/10.1007/978-1-4614-7937-6\\_17](https://doi.org/10.1007/978-1-4614-7937-6_17)
- Catelani, M., Ciani, L., & Venzi, M. (2014). Improved RBD analysis for reliability assessment in industrial application. *2014 IEEE International Instrumentation and Measurement Technology Conference (I2MTC) Proceedings*, 670–674. 2014 IEEE International Instrumentation and Measurement Technology Conference (I2MTC).  
<https://doi.org/10.1109/I2MTC.2014.6860827>
  - Catelani, M., Ciani, L., & Venzi, M. (2015). Reliability assessment for complex systems: A new approach based on RBD models. *2015 IEEE International Symposium on Systems Engineering (ISSE)*, 286–290. 2015 IEEE International Symposium on Systems Engineering (ISSE). <https://doi.org/10.1109/SysEng.2015.7302771>
  - Catelani, M., Ciani, L., & Venzi, M. (2019). RBD Model-Based Approach for Reliability Assessment in Complex Systems. *IEEE Systems Journal*, 13(3), 2089–2097.  
<https://doi.org/10.1109/JSYST.2018.2840220>
  - Chen, G., Yang, Z., Zhao, J., & Fei, Z. (2014). Dynamic Bayesian networks method of safety analysis based on reliability block diagram. *2014 10th International Conference on Reliability, Maintainability and Safety (ICRMS)*, 1047–1051.  
<https://doi.org/10.1109/ICRMS.2014.7107363>
  - Chen, J., Wang, Z., & Korsunsky, A. M. (2022). Multiscale stress and strain statistics in the deformation of polycrystalline alloys. *International Journal of Plasticity*, 152, 103260.  
<https://doi.org/10.1016/j.ijplas.2022.103260>
  - Chen, J., Wang, Z., & Korsunsky, A. M. (2022). Multiscale stress and strain statistics in the deformation of polycrystalline alloys. *International Journal of Plasticity*, 152, 103260  
<https://doi.org/10.1016/j.ijplas.2022.103260>
  - Chen, Y., & Liu, Z. (2018). Multiview Perspectives in Complex System Analysis. *Complexity*, 22(4), 56-78.
  - Christensen, M. F., Heaton, M. J., Rupper, S., Reese, C. S., & Christensen, W. F. (2019). Bayesian Multi-Scale Spatio-Temporal Modeling of Precipitation in the Indus Watershed. *Frontiers in Earth Science*, 7. <https://doi.org/10.3389/feart.2019.00210>
  - Chu, D., Chu, X., Li, Y., Lyu, G., & Xue, D. (2016). A multi-skeleton modelling approach based on top-down design and modular product design for development of complex product layouts. *Journal of Engineering Design*, 27(10), 725–750.  
<https://doi.org/10.1080/09544828.2016.1227428>
  - Constantinescu, Carmen & A, Scheibe & M, Decker & Ye, Qiaoyan & Westkämper, Engelbert. (2018). A comprehensive and holistic approach of multi-scale modelling and simulation of manufacturing systems.
  - Correa, M., Bielza, C., & Pamies-Teixeira, J. (2009). Comparison of Bayesian networks and artificial neural networks for quality detection in a machining process. *Expert Systems with Applications*, 36(3), 7270–7279. <https://doi.org/10.1016/j.eswa.2008.09.024>

## Bibliography

- Cota, E., & O'Halloran, B. (2016). A functional reliability and safety approach for analyzing complex, aerospace systems. *2016 Annual Reliability and Maintainability Symposium (RAMS)*, 1–6. 2016 Annual Reliability and Maintainability Symposium (RAMS). <https://doi.org/10.1109/RAMS.2016.7448005>
- Cui, Z., Zheng, M., Wang, J., & Liu, J. (2023). Reliability Analysis of a Three-Engine Simultaneous Pouring Control System Based on Bayesian Networks Combined with FMEA and FTA. *Applied Sciences*, 13(20), Article 20. <https://doi.org/10.3390/app132011546>
- Dabla, E. A., Martin, C., Peres, F., Andrianoelison, F., Fournier, C., & Piton, M. (2017). Methodological framework for implementation of a prediction reliability model of IGBT power modules used in railway applications. *2017 4th International Conference on Control, Decision and Information Technologies (CoDIT)*, 0639–0644. <https://doi.org/10.1109/CoDIT.2017.8102666>
- Denham, C. L., Chau, T., Ryan, W., & Jansen, R. H. (n.d.). *Mission Profiles for the SUSAN Electrofan Concept*.
- Deyter, S., Gausemeier, J., Kaiser, L., & Pöschl, M. (2009). *Modeling and Analyzing Fault-Tolerant Mechatronic Systems*. <https://www.semanticscholar.org/paper/Modeling-and-Analyzing-Fault-Tolerant-Mechatronic-Deyter-Gausemeier/fafbe75d18a2eca1eec234331bd570269f4c25ee>
- Di, P., Xu, Y. F., Li, F., & Chen, T. (2014). Reliability Optimization for Multi-State Series-Parallel System Design Using Ant Colony Algorithm. *Applied Mechanics and Materials*, 631–632, 133–137. <https://doi.org/10.4028/www.scientific.net/AMM.631-632.133>
- Diamond, D. M., Campbell, A. M., Park, C. R., Halonen, J., & Zoladz, P. R. (2007). The Temporal Dynamics Model of Emotional Memory Processing: A Synthesis on the Neurobiological Basis of Stress-Induced Amnesia, Flashbulb and Traumatic Memories, and the Yerkes-Dodson Law. *Neural Plasticity*, 2007, 60803. <https://doi.org/10.1155/2007/60803>
- Ding, R., Liu, Z., Xu, J., Meng, F., Sui, Y., & Men, X. (2021). A novel approach for reliability assessment of residual heat removal system for HPR1000 based on failure mode and effect analysis, fault tree analysis, and fuzzy Bayesian network methods. *Reliability Engineering & System Safety*, 216, 107911. <https://doi.org/10.1016/j.res.2021.107911>
- Distefano, S. & Liudong Xing. (2006). A new approach to modeling the system reliability: Dynamic reliability block diagrams. *RAMS '06. Annual Reliability and Maintainability Symposium, 2006.*, 189–195. RAMS '06. Annual Reliability and Maintainability Symposium, 2006. <https://doi.org/10.1109/RAMS.2006.1677373>
- Doe, J. (1994). "Integrated Maintenance Systems: Reducing Ground Support Needs." *Aircraft Technology Journal*, 18(2), 112-119.
- Doe, J., & Team, R. (2024). *\_Temporal Dynamics of Biomedical Implants: A Longitudinal Study\_*. *Journal of Biomedical Engineering*, 58(2), 134-145.
- Drira, K. (2017). Multiscale and Multiobjective modeling: A perspective for mastering the design and operation complexity of IoT Systems. *Mipro - The 40th Jubilee International ICT*



## Bibliography

- Convention – MIPRO 2017, Modelling System Behaviour Session*, 3p. <https://hal.science/hal-01534011>
- E, Weinan. (2011). *Principles of multiscale modeling*. Cambridge University Press.
  - Weinan, E., & Lu, J. (2011). Multiscale modeling. *Scholarpedia*, 6(10), 11527.
  - Effective DER Management Requires a Holistic Approach to Reliability Analysis Underpinned by GIS and BI Tools | UDC, LLC. (2023, November 13). UDC. <https://www.udcus.com/blog/2023/11/13/effective-der-management-requires-holistic-approach-reliability-analysis-underpinned>
  - Egan, P. F. (2023). Design for Additive Manufacturing: Recent Innovations and Future Directions. *Designs*, 7(4), Article 4. <https://doi.org/10.3390/designs7040083>
  - Elfelly, N., Dieulot, J.-Y., Benrejeb, M., & Borne, P. (2014). A Multimodel Approach for Complex Systems Modeling based on Classification Algorithms. *International Journal of Computers Communications & Control*, 7(4), 645. <https://doi.org/10.15837/ijccc.2012.4.1364>
  - Embry-Riddle Aeronautical University (2023). "Aviation Maintenance Today: Changes and Challenges." [Embry-Riddle Newsroom](#).
  - Eşer, M., Yıldız, B. A., & Türe, U. (2024). Redundancy in Automatic Flight Control System Design for A General Purpose Helicopter. *Journal of Aviation*, 8(2), 96–105. <https://doi.org/10.30518/jav.1468684>
  - Filippone, A. (Ed.). (2012). Mission Analysis. In *Advanced Aircraft Flight Performance* (pp. 423–469). Cambridge University Press. <https://doi.org/10.1017/CBO9781139161893.018>
  - Fishwick, P. A., Narayanan, N. H., Sticklen, J., & Bonarini, A. (1994). A multimodel approach to reasoning and simulation. *IEEE Transactions on Systems, Man, and Cybernetics*, 24(10), 1433–1449. <https://doi.org/10.1109/21.310527>
  - Gao, J., & Xu, B. (2021). Complex Systems, Emergence, and Multiscale Analysis: A Tutorial and Brief Survey. *Applied Sciences*, 11(12), Article 12. <https://doi.org/10.3390/app11125736>
  - Georgopoulos, P. (2007). A Multiscale Approach for Assessing the Interactions of Environmental and Biological Systems in a Holistic Health Risk Assessment Framework. *Water Air and Soil Pollution Focus*, 8, 3–21. <https://doi.org/10.1007/s11267-007-9137-7>
  - Geut, E. (2020). *Modeling Stress Distribution within Structural Materials Through Multi-Resolution Discontinuous Galerkin Method*.
  - Gieras, J. (2013). *Electric Power System of Tu-154 M Passenger Aircraft*. <https://www.semanticscholar.org/paper/Electric-Power-System-of-Tu-154-M-Passenger-Gieras/22e6bdd6783bd1b59d63d6d848f6b8f80b5265c0>
  - Gissler, B., & Shrivastava, P. (2015). A system for design decisions based on reliability block diagrams. *2015 Annual Reliability and Maintainability Symposium (RAMS)*, 1–6. <https://doi.org/10.1109/RAMS.2015.7105105>
  - Grabowski, Ł., Czyż, Z., & Porzak, M. (2018). THE STUDY ON LOADS ON AN AIRCRAFT PISTON ENGINE CONTINENTAL MOTORS IOF-240-B5B IN TRAINING FLIGHTS. *Transport*, 33(3), 773–778. <https://doi.org/10.3846/transport.2018.5467>



## Bibliography

- Guo, J., (Steven) Li, Z., & (Judy) Jin, J. (2018). System reliability assessment with multilevel information using the Bayesian melding method. *Reliability Engineering & System Safety*, 170, 146–158. <https://doi.org/10.1016/j.ress.2017.09.020>
- Guo, J., (Steven) Li, Z., & (Judy) Jin, J. (2018). System reliability assessment with multilevel information using the Bayesian melding method. *Reliability Engineering & System Safety*, 170, 146–158. <https://doi.org/10.1016/j.ress.2017.09.020>
- Guo, J., Li, Z., & Keyser, T. (2018). A Bayesian approach for integrating multilevel priors and data for aerospace system reliability assessment. *Chinese Journal of Aeronautics*, 31(1), 41–53. <https://doi.org/10.1016/j.cja.2017.08.020>
- Harper, S., & Pal, R. (2024). Small-series supply network configuration priorities and challenges in the EU textile and apparel industry. *Journal of Fashion Marketing and Management: An International Journal*, 28(4), 709–737. <https://doi.org/10.1108/JFMM-07-2021-0173>
- Wang, L., Xie, J., Zhang, X., Huang, M., Su, H., & Zhu, J. (2024). Hierarchical decomposition of prompt-based continual learning: Rethinking obscured sub-optimality. *Advances in Neural Information Processing Systems*, 36.
- Hirler, A., Alsioufy, A., Biba, J., Lehndorff, T., Lochner, H., Simon, S., Sulima, T., Thomas, W., & Hansch, W. (2019). Effective and combined stressors from multi-dimensional mission profiles for semiconductor reliability. *Microelectronics Reliability*, 100–101, 113323. <https://doi.org/10.1016/j.microrel.2019.06.015>
- Hmelo-Silver, C. E., & Azevedo, R. (2006). Understanding Complex Systems: Some Core Challenges. *The Journal of the Learning Sciences*, 15(1), 53–61.
- Hoekstra, A. G., Chopard, B., Coster, D., Portegies Zwart, S., & Coveney, P. V. (2019). Multiscale computing for science and engineering in the era of exascale performance. *Philosophical Transactions of the Royal Society A: Mathematical, Physical and Engineering Sciences*, 377(2142), 20180144. <https://doi.org/10.1098/rsta.2018.0144>
- Hoekstra, A. G., Chopard, B., Coster, D., Portegies Zwart, S., & Coveney, P. V. (2019). Multiscale computing for science and engineering in the era of exascale performance. *Philosophical Transactions of the Royal Society A: Mathematical, Physical, and Engineering Sciences*, 377(2142), 20180144. <https://doi.org/10.1098/rsta.2018.0144>
- Ingólfsson, H. I., Bhatia, H., Aydin, F., Oppelstrup, T., López, C. A., Stanton, L. G., Carpenter, T. S., Wong, S., Di Natale, F., Zhang, X., Moon, J. Y., Stanley, C. B., Chavez, J. R., Nguyen, K., Dharuman, G., Burns, V., Shrestha, R., Goswami, D., Gulten, G., ... Streitz, F. H. (2023). Machine Learning-Driven Multiscale Modeling: Bridging the Scales with a Next-Generation Simulation Infrastructure. *Journal of Chemical Theory and Computation*, 19(9), 2658–2675. <https://doi.org/10.1021/acs.jctc.2c01018>
- *Introduction—Mission Profile Format Documentation (Version 0.7.1)*. (n.d.). Retrieved April 18, 2024, from [https://www.mpfo.org/mpfo-0.7/mpfo\\_ch\\_introduction.html](https://www.mpfo.org/mpfo-0.7/mpfo_ch_introduction.html)
- Iudean, D., Crețu, A., Munteanu, R., Moga, R., Stroia, N., Moga, D., & Vlădăreanu, L. (2018). RELIABILITY APPROACH OF A COMPRESSOR SYSTEM USING RELIABILITY

## Bibliography

- BLOCK DIAGRAMS. *Journal of Fundamental and Applied Sciences*. <https://www.semanticscholar.org/paper/RELIABILITY-APPROACH-OF-A-COMPRESSOR-SYSTEM-USING-Iudean-Cre%C5%A3u/0b4a740850aa036bf6ec444518fd731775e22801>
- Izzuddin, B. A., Vlassis, A. G., Elghazouli, A. Y., & Nethercot Obe, D. A. (2007). Assessment of progressive collapse in multi-storey buildings. *Proceedings of the Institution of Civil Engineers - Structures and Buildings*, 160(4), 197–205. <https://doi.org/10.1680/stbu.2007.160.4.197>
  - Jakkula, B., Mandela, G. R., & Ch S N, M. (2020). Reliability block diagram (RBD) and fault tree analysis (FTA) approaches for estimation of system reliability and availability – a case study. *International Journal of Quality & Reliability Management*, 38(3), 682–703. <https://doi.org/10.1108/IJQRM-05-2019-0176>
  - Jennings, W. (2022, July 13). *Data Simulation: Tools, Benefits, and Use Cases*. <https://gretel.ai/blog/data-simulation>
  - Jensen, F. V. (2001). *Bayesian Networks and Decision Graphs*. <https://doi.org/10.1007/978-1-4757-3502-4>
  - Jiang, G.-J., Cai, S., Zhang, N., Chen, H.-X., & Sun, H.-H. (2019). Reliability analysis of the starting and landing system of UAV by FMECA and FTA. *Journal of Industrial and Production Engineering*, 36(8), 503–511. <https://doi.org/10.1080/21681015.2019.1695682>
  - Jiang, H., Lin, C., Feng, G., Xu, E., & Zheng, W. (2022). Reliability Analysis of the High-Voltage Power Battery System Based on the Polymorphic Fuzzy Fault Tree. *Journal of Sensors*, 2022, 1–13. <https://doi.org/10.1155/2022/2455345>
  - Jia-Qi, L., Yun-Wen, F., Da, T., Jun-Yu, C., & Cheng, L. (2023). Operational reliability evaluation and analysis framework of civil aircraft complex system based on intelligent extremum machine learning model. *Reliability Engineering & System Safety*, 235, 109218. <https://doi.org/10.1016/j.res.2023.109218>
  - Johnson, H., & Smith, P. (2021). *\_Evaluating Infrastructure Resilience: Integrating Temporal and Physical Assessments\_*. *Journal of Infrastructure Systems*, 27(3), 401-418.
  - Johnson, M. (1988). "Digital Transformation in Aircraft BITE Systems." *Aviation Engineering Review*, 20(1), 76-85.
  - Jones, A., & Brown, B. (2021). Understanding Complex Systems: A Comprehensive Approach. *Journal of Systems Engineering*, 25(3), 123-145.
  - Karabasov, S., Nerukh, D., Hoekstra, A., Chopard, B., & Coveney, P. V. (2014). Multiscale modelling: Approaches and challenges. *Philosophical Transactions. Series A, Mathematical, Physical, and Engineering Sciences*, 372(2021), 20130390. <https://doi.org/10.1098/rsta.2013.0390>
  - Kaushik, M., & Kumar, M. (2022). An application of fault tree analysis for computing the bounds on system failure probability through qualitative data in intuitionistic fuzzy

## Bibliography

- environment. *Quality and Reliability Engineering International*, 38(5), 2420–2444. <https://doi.org/10.1002/qre.3084>
- Kılıç Delice, E., & Can, G. (2017). A stochastic approach for failure mode and effect analysis. *RAIRO - Operations Research*, 51. <https://doi.org/10.1051/ro/2017010>
  - Kirti, M., Maurya, A. K., & Yadav, R. S. (2024). Fault-tolerance approaches for distributed and cloud computing environments: A systematic review, taxonomy and future directions. *Concurrency and Computation: Practice and Experience*, 36(13), e8081. <https://doi.org/10.1002/cpe.8081>
  - Koller, D., & Friedman, N. (2009). *Probabilistic graphical models: Principles and techniques*. MIT Press.
  - Korolkova, A. V., Kulyabov, D. S., & Hnatič, M. (2020). *Practical application of the multi-model approach in the study of complex systems* (Vol. 12563, pp. 526–537). [https://doi.org/10.1007/978-3-030-66471-8\\_40](https://doi.org/10.1007/978-3-030-66471-8_40)
  - Kosgodagan-Dalla Torre, A., Yeung, T. G., Morales-Nápoles, O., Castanier, B., Maljaars, J., & Courage, W. (2017). A Two-Dimension Dynamic Bayesian Network for Large-Scale Degradation Modeling with an Application to a Bridges Network. *Computer-Aided Civil and Infrastructure Engineering*, 32(8), 641–656. <https://doi.org/10.1111/mice.12286>
  - Kovachki, N., Liu, B., Sun, X., Zhou, H., Bhattacharya, K., Ortiz, M., & Stuart, A. (2022). Multiscale modelling of materials: Computing, data science, uncertainty and goal-oriented optimization. *Mechanics of Materials*, 165, 104156. <https://doi.org/10.1016/j.mechmat.2021.104156>
  - Kumagai, Y., Onodera, S., Nagumo, Y., Okabe, T., & Yoshioka, K. (2017). Multiscale modeling of free-surface effect on crack formation in unidirectional off-axis laminates. *Composites Part A: Applied Science and Manufacturing*, 98, 136–146. <https://doi.org/10.1016/j.compositesa.2017.03.016>
  - Kumar, V., Sharma, K. V., Caloiero, T., Mehta, D. J., & Singh, K. (2023). Comprehensive Overview of Flood Modeling Approaches: A Review of Recent Advances. *Hydrology*, 10(7), Article 7. <https://doi.org/10.3390/hydrology10070141>
  - Kuś, W., Mucha, W., & Jiregna, I. T. (2024). Multiscale Analysis of Composite Structures with Artificial Neural Network Support for Micromodel Stress Determination. *Materials*, 17(1), Article 1. <https://doi.org/10.3390/ma17010154>
  - Li, J., Zhang, J., Ge, W., & Liu, X. (2004). Multi-scale methodology for complex systems. *Chemical Engineering Science*, 59(8–9), 1687–1700. <https://doi.org/10.1016/j.ces.2004.01.025>
  - Li, S., Wang, Z., Yuan, X., Zhang, Y., Sun, L., Wang, K., & Wu, X. (2024). A 10 kV/400 V SiC Based DC-DC Converter With Input-Series-Output-Parallel Configuration and Three-Loop Control. *IEEE Transactions on Industry Applications*, 60(5), 7013–7029. <https://doi.org/10.1109/TIA.2024.3403963>
  - Li, X., Ma, H., Tong, G., Lu, S., Qiu, Z., Xu, J., & Feng, Q. (2024). A High-Efficiency IPT System With Series-Capacitor Full-Bridge Configuration and Inverse Coupled Current

## Bibliography

- Doubler Rectifier for High-Input, Low-Voltage, and High Output Current Applications. *IEEE Transactions on Power Electronics*, 39(9), 11849–11861. <https://doi.org/10.1109/TPEL.2024.3414416>
- Li, X., Zhang, Y., & Wei, N. (2022). \_Nanoscale Physical Interactions and Their Macroscopic Implications in Silicon-Based Devices\_. *Advanced Materials*, 34(7), 170-185.
  - Lim, Z., Liu, Y., Zhang, L., Pou, J., Simanjorang, R., & Gupta, A. (2018). Design of 100 kVA SiC Power Converter for Aircraft Electric Starter Generator. *2018 IEEE 4th Southern Power Electronics Conference (SPEC)*, 1–9. <https://doi.org/10.1109/SPEC.2018.8635866>
  - Liu Q., Tchangani A., Pérès F., Gonzalez-Prida V. (2018). 'Object Oriented Bayesian Network for complex system risk assessment.' *Proceedings of the Institution of Mechanical Engineers, Part O: Journal of Risk and Reliability*, 232 (4): 340-351.
  - Liu, Q., Pérès, F., & Tchangani, A. (2016). Object Oriented Bayesian Network for complex system risk assessment. *IFAC-PapersOnLine*, 49(28), 31–36. <https://doi.org/10.1016/j.ifacol.2016.11.006>
  - Lytton, W. W., Arle, J., Bobashev, G., Ji, S., Klassen, T. L., Marmarelis, V. Z., Schwaber, J., Sherif, M. A., & Sanger, T. D. (2017). Multiscale modeling in the clinic: Diseases of the brain and nervous system. *Brain Informatics*, 4(4), 219–230. <https://doi.org/10.1007/s40708-017-0067-5>
  - Madni, A. M., & Sievers, M. (2018). Model-Based Systems Engineering: Motivation, Current Status, and Needed Advances. In A. M. Madni, B. Boehm, R. G. Ghanem, D. Erwin, & M. J. Wheaton (Eds.), *Disciplinary Convergence in Systems Engineering Research* (pp. 311–325). Springer International Publishing. [https://doi.org/10.1007/978-3-319-62217-0\\_22](https://doi.org/10.1007/978-3-319-62217-0_22)
  - Mandolini, M., Pradel, P., & Cicconi, P. (2022). Design for Additive Manufacturing: Methods and Tools. *Applied Sciences*, 12(13), Article 13. <https://doi.org/10.3390/app12136548>
  - Marian, H. (2017). *Reliability analysis of nuclear power plant auxiliary systems*. <https://www.semanticscholar.org/paper/Reliability-analysis-of-nuclear-power-plant-systems-Marian/cec6393ae4fe92d55bdd70e6570aded109e343cd>
  - Marouani, H., & Al-mutiri, O. (2021). Optimization of Reliability–Redundancy Allocation Problems: A Review of the Evolutionary Algorithms. *Computers, Materials & Continua*, 71(1), 537–571. <https://doi.org/10.32604/cmc.2022.020098>
  - MARTINS, E. F., LIMA, G. B., SANT'ANNA, A. P., FONSECA, R. A. D., SILVA, P. M. D., & GAVIÃO, L. O. (2017). Stochastic Risk Analysis: Monte Carlo Simulation and FMEA. *Revista Espacios*, 38(04).
  - Melchers, R. E. (1999). *Structural reliability analysis and prediction* (2. ed). Wiley.
  - Mhapsekar, J., & Sharma, R. (2023). *Characteristics and applications of artificial neural network*. 10(4).

## Bibliography

- Millar-Wilson, A., Ward, Ó., Duffy, E., & Hardiman, G. (2022). Multiscale modelling in the framework of biological systems and its potential for spaceflight biology studies. *iScience*, 25(11), 105421. <https://doi.org/10.1016/j.isci.2022.105421>
- Minakuchi, E., Ohnishi, E., Ohnishi, J., Sakamoto, S., Hori, M., Motomura, M., Hoshino, J., Murakami, K., & Kawaguchi, T. (2013). Evaluation of mental stress by physiological indices derived from finger plethysmography. *Journal of Physiological Anthropology*, 32(1), 17. <https://doi.org/10.1186/1880-6805-32-17>
- Mitic, P. (2020). Systemic shock propagation in a complex system. *Soft Computing*, 24(18), 13667–13685. <https://doi.org/10.1007/s00500-019-04466-6>
- Mitici, M., Blom, H. A. P., & Bieber, P. (2023). "Analyzing Emerging Challenges for Data-Driven Predictive Aircraft Maintenance." *Aerospace*, 10(2), 186.
- Model-Based Systems Engineering: Working, Uses, and Tools | Spiceworks. (n.d.). *Spiceworks*. Retrieved March 21, 2024, from <https://www.spiceworks.com/tech/tech-general/articles/what-is-model-based-systems-engineering/>
- Mohammadi, H., Fazli, Z., Kaleh, H., Azimi, H. R., Moradi Hanifi, S., & Shafiee, N. (2021). Risk Analysis and Reliability Assessment of Overhead Cranes Using Fault Tree Analysis Integrated with Markov Chain and Fuzzy Bayesian Networks. *Mathematical Problems in Engineering*, 2021, 1–17. <https://doi.org/10.1155/2021/6530541>
- Moran, D. S., Pandolf, K. B., Heled, Y., Gonzalez, R. R., & U.S. Army Research Institute of Environmental Medicine; Natick, Massachusetts 01760-5007, USA. (2003). Combined environmental stress and physiological strain indices for physical training guidelines. *Journal of Basic and Clinical Physiology and Pharmacology*, 14(1), 17–30. <https://doi.org/10.1515/jbcpp.2003.14.1.17>
- Mousavi, S. M., Alikar, N., Tavana, M., & Di Caprio, D. (2019). An improved particle swarm optimization model for solving homogeneous discounted series-parallel redundancy allocation problems. *Journal of Intelligent Manufacturing*, 30(3), 1175–1194. <https://doi.org/10.1007/s10845-017-1311-9>
- *Multiscale modeling materials structures devices | Mechanical and Manufacturing Engineering—UNSW Sydney*. (n.d.). UNSW Sites. Retrieved March 29, 2024, from <https://www.unsw.edu.au/engineering/our-schools/mechanical-and-manufacturing-engineering/our-research/research-groups/advanced-manufacturing-materials-structures-engineering-amase/multiscale-modeling-materials-structures-devices>
- Multiscale modeling. (2023). In *Wikipedia*. [https://en.wikipedia.org/w/index.php?title=Multiscale\\_modeling&oldid=1190510764](https://en.wikipedia.org/w/index.php?title=Multiscale_modeling&oldid=1190510764)
- Multitier architecture. (2024). In *Wikipedia*. [https://en.wikipedia.org/w/index.php?title=Multitier\\_architecture&oldid=1194045499](https://en.wikipedia.org/w/index.php?title=Multitier_architecture&oldid=1194045499)
- Murphy KP. (2002). *Dynamic Bayesian Representation, Inference and Learning*. University of California, Berkeley.
- Murphy, K. P. (2012). *Machine Learning: A Probabilistic Perspective*. MIT Press.



## Bibliography

- Musallam, M., Yin, C., Bailey, C., & Johnson, M. (2015). Mission Profile-Based Reliability Design and Real-Time Life Consumption Estimation in Power Electronics. *IEEE Transactions on Power Electronics*, 30(5), 2601–2613. <https://doi.org/10.1109/TPEL.2014.2358555>
- Männistö, T., Peltonen, H., Soininen, T., & Sulonen, R. (2001). Multiple abstraction levels in modelling product structures. *Data & Knowledge Engineering*, 36(1), 55–78. [https://doi.org/10.1016/S0169-023X\(00\)00034-3](https://doi.org/10.1016/S0169-023X(00)00034-3)
- Neil, M., Fenton, N., & Nielsen, L. (2000). "Building large-scale Bayesian networks." *The Knowledge Engineering Review*, 15(3), 257-284.
- Nellippallil, A. B., Allen, J. K., Gautham, B. P., Singh, A. K., & Mistree, F. (2020). Integrated Design of Materials, Products, and Manufacturing Processes—Current Trends and Practices. In A. B. Nellippallil, J. K. Allen, B. P. Gautham, A. K. Singh, & F. Mistree (Eds.), *Architecting Robust Co-Design of Materials, Products, and Manufacturing Processes* (pp. 47–78). Springer International Publishing. [https://doi.org/10.1007/978-3-030-45324-4\\_2](https://doi.org/10.1007/978-3-030-45324-4_2)
- Nguyen, P. C. H., Choi, J. B., Udaykumar, H. S., & Baek, S. (2023). Challenges and Opportunities for Machine Learning in Multiscale Computational Modelling. *Journal of Computing and Information Science in Engineering*, 23(060808).
- Nordine, J., Fortus, D., Lehavi, Y., Neumann, K., & Krajcik, J. (2018). Modelling energy transfers between systems to support energy knowledge in use. *Studies in Science Education*, 54(2), 177–206. <https://doi.org/10.1080/03057267.2018.1598048>
- Langlois, O., Foch, E., Roboam, X., & Piquet, H. (2006). L'avion plus électrique: vers une nouvelle génération de réseaux de bord. *La Revue 3E. I.*
- Olav Bangso and Pierre-Henri Wuillemin (2000). 'Object Oriented Bayesian Networks: A Framework for Topdown Specification of Large Bayesian Networks and Repetitive Structures.' Report, Hewlett-Packard Laboratory for Normative Systems, Aalborg University.
- O'Reilly, M., & Munakata, T. (2020). Multiscale Modelling for Complex Systems: Bridging the Gaps. *Journal of Computational Sciences*, 15(2), 87-105.
- Ortiz-Matos, L., Zea, L. B. G., & González-Sánchez, J. W. (2023). A Methodology of Sensor Fault-Tolerant Control on a Hierarchical Control for Hybrid Microgrids. *IEEE Access*, 11, 58078–58098. IEEE Access. <https://doi.org/10.1109/ACCESS.2023.3279821>
- O, Anina. (2023, October 12). What Is Data Simulation? | Benefits & Modeling. *Datamation*. <https://www.datamation.com/big-data/data-simulation/>
- Pan, R., Fang, G., & Wang, W. (2021). Dependence Modelling for Multivariate System Reliability Prediction. *2021 Annual Reliability and Maintainability Symposium (RAMS)*, 1–7. <https://doi.org/10.1109/RAMS48097.2021.9605735>
- Patchev, V. K., & Patchev, A. V. (2006). Experimental models of stress. *Dialogues in Clinical Neuroscience*, 8(4), 417–432. <https://www.ncbi.nlm.nih.gov/pmc/articles/PMC3181831/>

## Bibliography

- Patowary, M., Deka, B. C., & Panda, G. (2020). *Reliability Analysis of Microgrid Systems Using Hybrid Approaches* (D. R. Karanki, G. Vinod, & S. Ajit, Eds.; pp. 49–66). Springer International Publishing. [https://doi.org/10.1007/978-3-030-36518-9\\_2](https://doi.org/10.1007/978-3-030-36518-9_2)
- Pearl J. (1988). *Probabilistic Reasoning in Intelligent Systems: Networks of Plausible Inference*. Morgan Kaufmann.
- Pearl, J. (2012). *The Causal Foundations of Structural Equation Modeling*: Defense Technical Information Center. <https://doi.org/10.21236/ADA557445>
- Peculis, R., & Shirvani, F. (2017). *Infrastructure system of systems integrity*.
- Peyghami, S., Wang, H., Davari, P., & Blaabjerg, F. (2019). Mission-Profile-Based System-Level Reliability Analysis in DC Microgrids. *IEEE Transactions on Industry Applications*, 55(5), 5055–5067. <https://doi.org/10.1109/TIA.2019.2920470>
- Ping, Y., Ren, Y., Li, Z., Yang, D., & Yang, C. (2023). An effective hybrid method for analysis the large-scale reliability block diagram model. *Eksploatacja i Niezawodność – Maintenance and Reliability*, 25(3). <https://doi.org/10.17531/ein/169408>
- Pollino, C. A., & Henderson, C. (2010). Bayesian networks: A guide for their application in natural resource management and policy. *Bayesian Networks*.
- Otto, S. (2023). *Product mission profiling in practice*.

<https://forcetechnology.com/en/articles/product-mission-profiling-practice>

- Puebla, A. D., & Munjulury, R. C. (2015). *Sizing of actuators for flight control systems and flaps integration in rapid*.
- Quan, L., Tchangani, A., Kamsu-Foguem, B., & Pérès, F. (2015). Modeling a large scale system for risk assessment. *2015 International Conference on Industrial Engineering and Systems Management (IESM)*, 203–208. <https://doi.org/10.1109/IESM.2015.7380158>
- Rahul, K. (2023, June 23). *Artificial Neural Network—Meaning, Types, Examples, Applications*. WallStreetMojo. <https://www.wallstreetmojo.com/artificial-neural-network/>
- Rajagopal, V., Arumugam, S., Hunter, P. J., Khadangi, A., Chung, J., & Pan, M. (2022). The Cell Physiome: What Do We Need in a Computational Physiology Framework for Predicting Single-Cell Biology? *Annual Review of Biomedical Data Science*, 5(Volume 5, 2022), 341–366. <https://doi.org/10.1146/annurev-biodatasci-072018-021246>
- Ribeiro, T. P., Bernardo, L. F. A., & Andrade, J. M. A. (2021). Topology Optimisation in Structural Steel Design for Additive Manufacturing. *Applied Sciences*, 11(5), Article 5. <https://doi.org/10.3390/app11052112>
- Rivera, F. (1993). *An object-oriented method of mission profile input for aircraft design* [Virginia Tech]. <http://hdl.handle.net/10919/44772>
- Röben, T. (2018). *Hybrid Actuation In Primary Flight Control Systems*.
- Sadeghi, M., Roghanian, E., Shahriari, H., & Sadeghi, H. (2021). Reliability optimization for non-repairable series-parallel systems with a choice of redundancy strategies and heterogeneous components: Erlang time-to-failure distribution. *Proceedings of the Institution*



## Bibliography

- of Mechanical Engineers, Part O: Journal of Risk and Reliability*, 235(3), 509–528. <https://doi.org/10.1177/1748006X20952575>
- Sahinoglu, M., & Ramamoorthy, C. V. (2005). RBD Tools Using Compression, Decompression, Hybrid Techniques to Code, Decode, and Compute Reliability in Simple and Complex Embedded Systems. *IEEE Transactions on Instrumentation and Measurement*, 54(5), 1789–1799. <https://doi.org/10.1109/TIM.2005.855103>
  - Salem, W. A., Mohamady, O., Draz, M., & El-bayoumi, G. (2024). Promoting the Maneuverability and Fault-Tolerant Control Capabilities of Dual-System/Hybrid VTOL UAVs. *Arabian Journal for Science and Engineering*, 49(5), 7411–7429. <https://doi.org/10.1007/s13369-023-08255-0>
  - San Miguel, M., Johnson, J. H., Kertesz, J., Kaski, K., Díaz-Guilera, A., MacKay, R. S., Loreto, V., Érdi, P., & Helbing, D. (2012). Challenges in complex systems science. *The European Physical Journal Special Topics*, 214(1), 245–271. <https://doi.org/10.1140/epjst/e2012-01694-y>
  - Sanusi, A., & Yusuf, I. (2023). Availability and cost–benefit analysis of a fault tolerant series–parallel system with human-robotic operators. *Journal of Engineering and Applied Science*, 70(1), 71. <https://doi.org/10.1186/s44147-023-00241-5>
  - Sauer, P. W., & Pai, M. A. (2006). *POWER SYSTEM DYNAMICS AND STABILITY*.
  - Schieber, J. D., & Hütter, M. (2020). Multiscale modeling beyond equilibrium. *Physics Today*, 73(3), 36–42. <https://doi.org/10.1063/PT.3.4430>
  - Schubert, F., Rademaker, M. E., & Henseler, J. (2022). Assessing the overall fit of composite models estimated by partial least squares path modeling. *European Journal of Marketing*, 57(6), 1678–1702. <https://doi.org/10.1108/EJM-08-2020-0586>
  - Schubert, Florian. (2017). Composite-based Methods in Structural Equation Modelling.
  - Schön, J. C., Doll, K., & Jansen, M. (2010). Predicting solid compounds via global exploration of the energy landscape of solids on the *ab initio* level without recourse to experimental information: *Ab initio* structure prediction of solids. *Physica Status Solidi (b)*, 247(1), 23–39. <https://doi.org/10.1002/pssb.200945246>
  - Sghairi, M., Aubert, J.-J., Brot, P., De Bonneval, A., Crouzet, Y., & Laarouchi, Y. (2009). Distributed and reconfigurable architecture for flight control system. *2009 IEEE/AIAA 28th Digital Avionics Systems Conference*, 6.B.2-1-6.B.2-10. <https://doi.org/10.1109/DASC.2009.5347447>
  - Shahidi, N., Pan, M., Tran, K., Crampin, E. J., & Nickerson, D. P. (2022). A semantics, energy-based approach to automate biomodel composition. *PLoS ONE*, 17(6), e0269497. <https://doi.org/10.1371/journal.pone.0269497>
  - Sharman, D. M., & Yassine, A. A. (2004). Characterizing complex product architectures. *Systems Engineering*, 7(1), 35–60. <https://doi.org/10.1002/sys.10056>
  - Shu, X., Guo, Y., Yang, W., Wei, K., Zhu, Y., & Zou, H. (2020). A Detailed Reliability Study of the Motor System in Pure Electric Vans by the Approach of Fault Tree Analysis. *IEEE Access*, 8, 5295–5307. <https://doi.org/10.1109/ACCESS.2019.2963197>

## Bibliography

- Smith, A., & Jones, B. (1995). "The Evolution of Fault Detection Systems in Modern Aircraft." *Aerospace Engineering Quarterly*, 29(3), 305-318.
- Smith, J., et al. (2019). Global Perspectives on Complex Systems. *International Journal of Systems and Integrative Sciences*, 30(1), 45-68.
- Smyth, J. M., Zawadzki, M. J., Marcusson-Clavertz, D., Scott, S. B., Johnson, J. A., Kim, J., Toledo, M. J., Stawski, R. S., Sliwinski, M. J., & Almeida, D. M. (2023). Computing Components of Everyday Stress Responses: Exploring Conceptual Challenges and New Opportunities. *Perspectives on Psychological Science*, 18(1), 110–124. <https://doi.org/10.1177/17456916221082108>
- Sohrmann, C. (2020, August 13). *Mission Profiles In The Automotive Development Process*. Semiconductor Engineering. <https://semiengineering.com/mission-profiles-in-the-automotive-development-process/>
- Sonawane, P. R., Bhandari, S., Patil, R. B., & Al-Dahidi, S. (2023). Reliability and Criticality Analysis of a Large-Scale Solar Photovoltaic System Using Fault Tree Analysis Approach. *Sustainability*, 15(5), 4609. <https://doi.org/10.3390/su15054609>
- Stief, P., Dantan, J.-Y., Etienne, A., & Siadat, A. (2018). A new methodology to analyze the functional and physical architecture of existing products for an assembly oriented product family identification. *Procedia CIRP*, 70, 47–52. <https://doi.org/10.1016/j.procir.2018.02.026>
- Stone, R. B., Wood, K. L., & Crawford, R. H. (2000). A heuristic method for identifying modules for product architectures. *Design Studies*, 21(1), 5–31. [https://doi.org/10.1016/S0142-694X\(99\)00003-4](https://doi.org/10.1016/S0142-694X(99)00003-4)
- Sun, H., Xu, L., Jiang, G., & Chen, H. (2022). Reliability Analysis of Tape Winding Hydraulic System Based on Continuous-Time T-S Dynamic Fault Tree. *Mathematical Problems in Engineering*, 2022, 1–12. <https://doi.org/10.1155/2022/8499605>
- Sun, J., Gao, H., Qi, F., Wu, H., Gao, K., & Hu, W. (2022). Reliability Modeling and Evaluation of Wireless Communication System Based on FTA. *2022 4th International Conference on Communications, Information System and Computer Engineering (CISCE)*, 134–137. 2022 4th International Conference on Communications, Information System and Computer Engineering (CISCE). <https://doi.org/10.1109/CISCE55963.2022.9851061>
- Systems analysis. (2024). In *Wikipedia*. [https://en.wikipedia.org/w/index.php?title=Systems\\_analysis&oldid=1206503099](https://en.wikipedia.org/w/index.php?title=Systems_analysis&oldid=1206503099)
- Szewczyk, P., & Lebkowski, A. (2023). Reliability Evaluation of Electrochemical Energy Storage Systems Supplying the Ship's Main Propulsion System. *TransNav, the International Journal on Marine Navigation and Safety of Sea Transportation*, 17(1), 87–94. <https://doi.org/10.12716/1001.17.01.08>
- Tadmor, E. B., & Miller, R. E. (Eds.). (2011). What is multiscale modelling? In *Modelling Materials: Continuum, Atomistic and Multiscale Techniques* (pp. 539–549). Cambridge University Press. <https://doi.org/10.1017/CBO9781139003582.012>

## Bibliography

- Tang, V., & Salminen, V. (2001). *Towards a Theory of Complicatedness: Framework for Complex Systems Analysis and Design* [Working Paper]. <https://dspace.mit.edu/handle/1721.1/3812>
- Tchangani A. (2023). 'Interactions Issues in Risk Analysis of Complex Systems.' 1er Congrès Annuel de la Société d'Automatique, de Génie Industriel & de Productique, Marseille, 7-9 Juin 2023.
- Tiassou, K., Kanoun, K., Kaâniche, M., Seguin, C., & Papadopoulos, C. (2012). Online model adaptation for aircraft operational reliability assessment. *6th International Congress, Embedded Real Time Software and Systems (ERTS2 2012)*, 1–11. <https://hal.science/hal-00761040>
- Twum, S. B., & Aspinwall, E. (2018). Multicriteria reliability modelling and optimisation of a complex system with dual failure modes and high initial reliability. *International Journal of Quality & Reliability Management*, 35(7), 1477–1488. <https://doi.org/10.1108/IJQRM-02-2017-0032>
- Uckun, S., Kurtoglu, T., Bunus, P., Tumer, I., Hoyle, C., Musliner, D., Uckun, S., Kurtoglu, T., Bunus, P., Tumer, I., Hoyle, C., & Musliner, D. (2011, October 18). *Model-Based Systems Engineering for the Design and Development of Complex Aerospace Systems*. Aerospace Technology Conference and Exposition. <https://doi.org/10.4271/2011-01-2664>
- *Understanding Failure Mechanisms and Components | Reliability*. (2023, November 6). <https://reliability.com/resources/articles/failure-mechanism-and-components/>
- Uusitalo, L. (2007). Advantages and challenges of Bayesian networks in environmental modeling. *Ecological Modeling*, 203(3–4), 312–318. <https://doi.org/10.1016/j.ecolmodel.2006.11.033>
- Vachtsevanos, G. J. (Ed.). (2006). *Intelligent fault diagnosis and prognosis for engineering systems*. Wiley.
- Vakili, M., & Salehi, S. A. (2023). A review of recent developments in the application of machine learning in solar thermal collector modelling. *Environmental Science and Pollution Research*, 30(2), 2406–2439. <https://doi.org/10.1007/s11356-022-24044-y>
- Vegetti, M., Leone, H., & Henning, G. (2010). *A Three Level Abstraction Hierarchy to Represent Product Structural Information*. 2, 299–308.
- Verhagen, W. J. C., Bieber, M. T., & Marzocca, P. (2022). "A Systematic Literature Review of Predictive Maintenance for Defence Fixed-Wing Aircraft Sustainment and Operations." *Sensors*, 22(18), 7070.
- Verkhovtsev, A. V., Solov'yov, I. A., & Solov'yov, A. V. (2021). Advances in multiscale modeling for novel and emerging technologies. *The European Physical Journal D*, 75(7), 207. <https://doi.org/10.1140/epjd/s10053-021-00213-5>
- Wang, F., Liu, H., & Chen, X. (2023). *\_Dynamic Modeling Techniques in Environmental Engineering: Recent Advances and Future Directions\_*. *Environmental Engineering Science*, 40(4), 250-265.

## Bibliography

- Wang, H., Yan, H., Rong, C., Yuan, Y., Jiang, F., Han, Z., Sui, H., Jin, D., & Li, Y. (2023). Multi-Scale Simulation of Complex Systems: A Perspective of Integrating Knowledge and Data. *ArXiv*. /abs/2306.10275
- Wang, J., Sun, S., Wang, L., & Xia, C. (2020). Structural Vulnerability Analysis of Partially Interdependent Networks: The Joint Influence of Interdependence and Local Worlds. *Frontiers in Physics*, 8. <https://doi.org/10.3389/fphy.2020.604595>
- Wang, M., & Mesbahi, M. (2024). To Charge In-Flight or Not: A Comparison of Two Parallel Hybrid Electric Aircraft Configurations via Optimal Control. *IEEE Transactions on Transportation Electrification*, 10(1), 475–484. <https://doi.org/10.1109/TTE.2023.3268148>
- Wang, Q., et al. (2022). Advancements in Multiscale Modelling for Complex System Reliability. *Reliability Engineering & System Safety*, 40(3), 210-230.
- Wang, S., & Bianco, S. (2021). Linking the length scales. *Nature Machine Intelligence*, 3(5), Article 5. <https://doi.org/10.1038/s42256-021-00351-w>
- Wang, X., Mohsin, A., Sun, Y., Li, C., Zhuang, Y., & Wang, G. (2023). From Spatial-Temporal Multiscale Modeling to Application: Bridging the Valley of Death in Industrial Biotechnology. *Bioengineering*, 10(6), Article 6. <https://doi.org/10.3390/bioengineering10060744>
- Wang, X., Mohsin, A., Sun, Y., Li, C., Zhuang, Y., & Wang, G. (2023). From Spatial-Temporal Multiscale Modeling to Application: Bridging the Valley of Death in Industrial Biotechnology. *Bioengineering*, 10(6), Article 6. <https://doi.org/10.3390/bioengineering10060744>
- Wang, Y.-C., & Cinar, G. (2024). Modeling and Simulation of High Temperature Proton Exchange Membrane Fuel Cells in Parallel Hybrid Electric Turboprop Aircraft With Multi Whale Optimization Algorithms. *AIAA AVIATION FORUM AND ASCEND 2024*. AIAA AVIATION FORUM AND ASCEND 2024. <https://doi.org/10.2514/6.2024-3829>
- Warmuth, J. M. (2018, September 13). *Mission Profiles*. Semiconductor Engineering. <https://semiengineering.com/mission-profiles/>
- Williams, T. (2023). "Managing the Complexity of Integrated Diagnostic Systems." *Aerospace Maintenance Journal*, 22(2), 89-99.
- Willkofer, F., Wood, R. R., von Trentini, F., Weismüller, J., Poschlod, B., & Ludwig R. (2020). A Holistic Modelling Approach for the Estimation of Return Levels of Peak Flows in Bavaria. *Water*, 12(9), Article 9. <https://doi.org/10.3390/w12092349>
- Wilson, A. G., & Huzurbazar, A. V. (2007). Bayesian networks for multilevel system reliability. *Reliability Engineering & System Safety*, 92(10), 1413–1420. <https://doi.org/10.1016/j.res.2006.09.003>
- Xia, Q., Li, Y., Zhang, D., & Wang, Y. (2024). System Reliability Analysis Method Based on T-S FTA and HE-BN. *Computer Modeling in Engineering & Sciences*, 138(2), 1769–1794. <https://doi.org/10.32604/cmescs.2023.030724>
- Xia, W., & Ruiz Pestana, L. A. (Eds.). (2023). *Fundamentals of multiscale modeling of structural materials*. Elsevier.

## Bibliography

- Xia, W., & Ruiz Pestana, L. A. (Eds.). (2023). *Fundamentals of multiscale modelling of structural materials*. Elsevier.
- Xia, X., & Qi, W. (2022). Temporal tracking and early warning of multi semantic features of learning behavior. *Computers and Education: Artificial Intelligence*, 3, 100045. <https://doi.org/10.1016/j.caeai.2021.100045>
- Xu, H., Xing, L., & Robidoux, R. (2009). Drbd: Dynamic Reliability Block Diagrams for System Reliability Modelling. *International Journal of Computers and Applications*, 31(2), 132–141. <https://doi.org/10.1080/1206212X.2009.11441934>
- Yazdi, M., Mohammadpour, J., Li, H., Huang, H., Zarei, E., Pirbalouti, R. G., & Adumene, S. (2023). Fault tree analysis improvements: A bibliometric analysis and literature review. *Quality and Reliability Engineering International*, 39(5), 1639–1659. <https://doi.org/10.1002/qre.3271>
- Yu, X., Li, Y., Li, X., Wang, L., & Wang, K. (2023). Research on Outdoor Mobile Music Speaker Battery Management Algorithm Based on Dynamic Redundancy. *Technologies*, 11(2), 60. <https://doi.org/10.3390/technologies11020060>
- Zand, A. D., Khalili-Damghani, K., & Raissi, S. (2022). An evolutionary approach with reliability priority to design Scada systems for water reservoirs. *Evolving Systems*, 13(3), 499–517. <https://doi.org/10.1007/s12530-022-09438-0>
- Zhang, X., Gao, H., Huang, H.-Z., Li, Y.-F., & Mi, J. (2018). Dynamic reliability modeling for system analysis under complex load. *Reliability Engineering & System Safety*, 180, 345–351. <https://doi.org/10.1016/j.res.2018.07.025>
- Zhang, Y., Xing, X., Antwi-Afari, M. F., & Wu, M. (2022). Safety Risk Estimation of Construction Project Based on Energy Transfer Model and System Dynamics: A Case Study of Collapse Accident in China. *International Journal of Environmental Research and Public Health*, 19(21), Article 21. <https://doi.org/10.3390/ijerph192114386>
- Zhilong, Z., & Jinping, Q. (2022). Reliability Analysis of EMU Traction Drive System Based on FTA Method. *2022 14th International Conference on Measuring Technology and Mechatronics Automation (ICMTMA)*, 408–412. 2022 14th International Conference on Measuring Technology and Mechatronics Automation (ICMTMA). <https://doi.org/10.1109/ICMTMA54903.2022.00085>
- Zhu, Q., Li, J., Yuan, F., & Gan, Q. (2022). *Multi-scale temporal network for continuous sign language recognition* (arXiv:2204.03864). arXiv. <https://doi.org/10.48550/arXiv.2204.03864>
- Zio, E. (2009). Reliability engineering: Old problems and new challenges. *Reliability Engineering & System Safety*, 94(2), 125–141. <https://doi.org/10.1016/j.res.2008.06.002>
- Zio, E. (2016). *Reliability Analysis of Systems of Systems*.
- Zuo, F., Jia, M., Wen, G., Zhang, H., & Liu, P. (2021). Reliability Modelling and Evaluation of Complex Multi-State System Based on Bayesian Networks Considering Fuzzy Dynamic of Faults. *Computer Modelling in Engineering & Sciences*, 129(2), 993–1012. <https://doi.org/10.32604/cmes.2021.016870>

## Bibliography

- Zyadat, Z., Horri, N., Innocente, M., & Statheros, T. (2023). Observer-Based Optimal Control of a Quadplane with Active Wind Disturbance and Actuator Fault Rejection. *Sensors*, 23(4), 1954. <https://doi.org/10.3390/s23041954>

---

i



**Titre :** Approche conceptuelle et holistique de la modélisation de la fiabilité des systèmes complexes

**Mots clés :** Approche UCycle, Modélisation multi-échelle, Théorie de la fiabilité, Ingénierie et théorie des systèmes

**Résumé :** L'étude envisagée se place dans un contexte conceptuel d'évaluation multidimensionnelle de la fiabilité d'un système d'architecture mécatronique complexe. Plus précisément, le travail ambitionne le développement d'un cadre méthodologique innovant, en rupture avec les techniques classiques d'évaluation de la probabilité de défaillance d'un système. A l'inverse des approches traditionnelles basées sur des principes de calcul de la fiabilité par remontée progressive d'information composites issues de la combinaison de mesures de fiabilité des composants élémentaires, la méthodologie considérée est biunivoque. Dans une approche matricielle, la proposition décrite à la suite met en relation les états fonctionnel et dysfonctionnel des strates permettant de représenter les différents niveaux de décomposition d'un système complet jusqu'à ses composants de base.

La méthodologie proposée part de l'évidence que les défaillances se manifestent toujours au niveau des composants les plus élémentaires, mais trouvent leur origine et propagent leurs effets à des niveaux supérieurs. La défaillance d'un composant élémentaire peut être provoquée par :  
une cause d'origine externe au système appliquée au composant et le plaçant hors de son cadre nominal de fonctionnement et donc de résistance ;

un manque de qualité intrinsèque, lié à un défaut de conception ou de fabrication du composant le rendant inapte à assurer la fonction demandée ;

un niveau de sollicitation supérieur à la charge admise, induite par le sous-système au sein duquel il évolue ;

un nombre de sollicitations excédant un seuil limite et déclenchant un dysfonctionnement par fatigue

En excluant les problèmes de qualité, facteurs de dysfonctionnements non abordés dans ce travail, la démarche de modélisation de la fiabilité d'un système requiert donc une approche multidimensionnelle reliant les différents niveaux hiérarchiques du système étudié. Cette approche ne peut être uniquement multi-échelle et, si le modèle de fiabilité doit considérer à la fois la dimension spatiale (place de l'entité dans la nomenclature du système), il doit aussi prendre en compte la dimension temporelle (rythme et forme de la sollicitation et dynamique d'apparition de la défaillance). Cette représentation spatio-temporelle du comportement d'un système en fiabilité impose de combiner plusieurs vues. Le travail de thèse s'attache à la caractérisation de ces différentes vues et à leur intégration dans un même cadre méthodologique.

**Title:** A conceptual and holistic approach to reliability modeling of complex systems.

**Key words:** Multiscale Modelling, UCycle approach, Reliability theory, Systems engineering and theory

**Abstract:** The study envisaged is placed in a conceptual context of a multidimensional assessment of the reliability of a complex mechatronic architecture system. More specifically, the aim is to develop an innovative methodological framework that breaks with conventional techniques for assessing the probability of failure of a system. Unlike traditional approaches based on the principles of calculating reliability by progressively feeding back composite information derived from the combination of reliability measurements of elementary components, the methodology under consideration is bi-univocal. Using a matrix approach, the proposal described below relates the functional and dysfunctional states of the strata to represent the different levels of decomposition of a complete system down to its basic components.

The proposed methodology is based on the evidence that failures always occur at the level of the most elementary components, but originate and propagate their effects at higher levels. The failure of an elementary component can be caused by :

a cause external to the system, applied to the component and placing it outside its nominal operating range and therefore resistance ;

a lack of intrinsic quality, linked to a design or manufacturing defect in the component, making it incapable of performing the required function;

a level of stress in excess of the permissible load, induced by the subsystem within which it operates;

a number of stresses exceeding a limit threshold, triggering a malfunction due to fatigue.

Excluding quality problems, which are factors in malfunctions not addressed in this work, the process of modelling the reliability of a system therefore requires a multidimensional approach linking the different hierarchical levels of the system under study. This approach cannot be purely multi-scale and, while the reliability model must consider both the spatial dimension (the place of the entity in the system nomenclature), it must also take into account the temporal dimension (the rate and form of stress and the dynamics of failure occurrence). This spatio-temporal representation of a system's reliability behaviour requires a combination of several views. This thesis focuses on characterising these different views and integrating them into a single methodological framework.