



**HAL**  
open science

# Ubiquitous sensor network in the NGN environment

Adel Mounir Sareh Said

► **To cite this version:**

Adel Mounir Sareh Said. Ubiquitous sensor network in the NGN environment. Networking and Internet Architecture [cs.NI]. Institut National des Télécommunications; Université Aïn-Chams (Le Caire), 2014. English. NNT : 2014TELE0016 . tel-01172628

**HAL Id: tel-01172628**

**<https://theses.hal.science/tel-01172628v1>**

Submitted on 7 Jul 2015

**HAL** is a multi-disciplinary open access archive for the deposit and dissemination of scientific research documents, whether they are published or not. The documents may come from teaching and research institutions in France or abroad, or from public or private research centers.

L'archive ouverte pluridisciplinaire **HAL**, est destinée au dépôt et à la diffusion de documents scientifiques de niveau recherche, publiés ou non, émanant des établissements d'enseignement et de recherche français ou étrangers, des laboratoires publics ou privés.



Faculty of Engineering

**Thèse présentée pour l'obtention du Diplôme de Docteur**

**These de Doctorat conjoint Telecom Sudparis et l'Université Pierre et Marie Curie en cotutelle avec Ain Shams University**

**Spécialité : Informatique et Télécommunications**

**Ecole Doctorale: EDITE et Faculty of Engineering (Ain Shams University)**

Présentée Par

**Adel Mounir Sareh Said**

Titre

**“Réseaux de capteurs ubiquitous dans l'environnement NGN”**

Soutenue le: 6/9/2014

**Devant le jury composé de:**

<b>Mme. Hassnaa Moustafa</b>	<b>Rapporteur (côté Français)</b>	<b>Intel, États-Unis</b>
<b>Mr. Mohamed Abo El-Dhab</b>	<b>Rapporteur (côté Egyptien)</b>	<b>Arab Academy for Science, Technology &amp; Maritime (AAST)</b>
<b>Mme. Amani Sabri Amin</b>	<b>Rapporteur</b>	<b>National Telecommunication Institute (NTI)</b>
<b>Mr. Guy Pujolle</b>	<b>Examineur</b>	<b>UPMC</b>
<b>Mr. Michel Marot</b>	<b>Examineur</b>	<b>Télécom SudParis</b>
<b>Mr. Hossam Afifi</b>	<b>Directeur de thèse (côté Français)</b>	<b>Télécom SudParis</b>
<b>Mme. Hadia Elhennawy</b>	<b>Directeur de thèse (côté Egyptien)</b>	<b>Ain Sham University</b>
<b>Mr. Ashraf William</b>	<b>Co-encadrant de these (côté Egyptien)</b>	<b>National Telecommunication Institute (NTI)</b>
<b>Mr. Abderrahim Benslimane</b>	<b>Invité</b>	<b>Université d'Avignon</b>

**Thèse n° 2014TELE0016**



Faculty of Engineering

**Thesis Submitted in Fulfillment of the Requirements for the Degree of Doctor of  
Philosophy**

**PhD Thesis Supervised Conjointly Between Ain Shams University, Telecom SudParis,  
and L'Université Pierre et Marie Curie**

**Special:** Information and Telecommunication

**Ecole Doctorale:** EDITE & Faculty of Engineering (Ain Shams University)

Presented By:

**Adel Mounir Sareh Said**

Title

**“Ubiquitous Sensor Network in the NGN Environment”**

Defense Date: 6/9/2014

**Jury Board:**

<b>Mrs. Hassnaa Moustafa</b>	<b>Reviewer (French side)</b>	<b>USA Intel</b>
<b>Mr. Mohamed Abo El-Dhab</b>	<b>Reviewer (Egyptian side)</b>	<b>Arab Academy for Science, Technology &amp; Maritime (AAST)</b>
<b>Mrs. Amani Sabri Amin</b>	<b>Reviewer</b>	<b>National Telecommunication Institute (NTI)</b>
<b>Mr. Guy Pujolle</b>	<b>Examiner</b>	<b>UPMC</b>
<b>Mr. Michel Marot</b>	<b>Examiner</b>	<b>Télécom SudParis</b>
<b>Mr. Hossam Afifi</b>	<b>Thesis Supervisor (French side)</b>	<b>Télécom SudParis</b>
<b>Mrs. Hadia Elhennawy</b>	<b>Thesis Supervisor (Egyptian side)</b>	<b>Ain Sham University</b>
<b>Mr. Ashraf William</b>	<b>Co-Supervisor (Egyptian side)</b>	<b>National Telecommunication Institute (NTI)</b>
<b>Mr. Abderrahim Benslimane</b>	<b>Invited</b>	<b>Université d'Avignon</b>

**Thèse n° 2014TELE0016**

## Abstract

Ubiquitous Sensor Network (USN) is a conceptual network built over existing physical networks. It makes use of sensed data and provides knowledge services to anyone, anywhere, and at any time, and where the data is generated by using context awareness. USNs and smart wearable devices are emerging rapidly providing many reliable services facilitating people life. Those very useful small end terminals and devices require a global communication substrate to provide a comprehensive global end user service. In 2010, the ITU-T provided the requirements to support USN applications and services in the Next Generation Network (NGN) environment. One of the main promising domains for the USN application and services is the e-Health. It provides continuous patients monitoring and enables a great improvement in medical services. On the other hand, Vehicular Ad-Hoc NETWORK (VANET) is an emerging technology, which provides intelligent communication between mobile vehicles. Integrating VANET with USN has a great potential to improve road safety and traffic efficiency.

This thesis proposes the use of the IP Multimedia Subsystem (IMS) as a service controller sub-layer in the USN environment providing a global substrate for a comprehensive end-to-end service. Moreover, the integration of VANETs and USN is proposed for more rich applications and facilities, which will ease the life of humans.

One of the challenges to achieve this goal is the limited capabilities of the sensor network such as bandwidth, low processing power, and memory size. Therefore, there is a need for a protocol that deliver sensors data in an energy-efficient way to the sink. One of those techniques is to gather the sensors data in small size packets suitable for transmission.

First, this thesis proposes a new effective Data Aggregation Protocol (DAP) to reduce the energy consumption in Wireless Sensor Networks (WSNs), which prolongs the network lifetime. This protocol uses in-network aggregation approach to distribute the processing all over the aggregation path to avoid unbalanced power consumption on specific nodes until they run out. From the simulation results, DAP achieves superior performance and better energy consumption, and consequently extends network lifetime.

---

Second, a detailed network architecture is proposed for USN based IMS for implementing the proposed e-Health service with emphasizes on middleware layer entities functions. It is simple, flexible, and does not require great changes in the already established communication networks. The thesis provided a detailed network signaling flow for different applicable e-Health scenarios using Session Initiation Protocol (SIP) and proposed a modification in the SIP to match the features provided in the proposed e-Health service. Moreover, emergency cases detection technique is proposed, which is practically vital to save patients life. The evaluation of the proposal proves the ability implement the proposed e-Health scenarios and the reliability of the new signaling model.

Finally, a new end-to-end model for the safety on roads is proposed, that is based on using IMS as a service controller sub-layer to VANETs. Integrating VANET with USN has a great potential to improve road safety and traffic efficiency. Most VANET applications are applied in real time and hence they are sensitive to delay, especially those related to safety and health. Therefore, checking the applicability of any proposed application is very important. One way to achieve this is by calculating the Round Trip Time (RTT), which is the time taken by a VANET application starting from the initiator node (source vehicle) sending a message until receiving a response from the core network. In this thesis, a new complete analytical model is proposed to calculate the RTT of VANET applications. To the best of my knowledge, there is no previous published work that either studied the RTT of VANET applications or developed a complete architecture to implement them by integrating VANETs with USNs and IMS. The RTT is calculated by combining two analytical models. Firstly, an analytical model is developed to calculate the time needed for the communication between two nodes on a road. Secondly, a queuing model using Baskett Chandy Muntz Palacios (BCMP) queuing network is developed for the IMS servers to calculate the proposed application execution time in the core network. These models are general enough to be applied to any VANET application. Finally, to assess the validity and the accuracy of the proposed architecture and models, three different tools are used: C++, Matlab, and OPNET. The analytical results were compared to the simulation results to evaluate their consistency.

In conclusion, the proposed contributions in this thesis will help to improve the global communication substrate for more applications that are useful for the human life based on the proposed network architecture. In addition, the proposed analytical models

---

will enrich the literature in terms of constructing suitable models to evaluate end-to-end complex networks.

**Keywords:** Ubiquitous Sensor Network, WSN, Next Generation Network, IP Multimedia Subsystem, Session Initiation Protocol, Vehicular Ad-hoc Network.

## Résumé

Ubiquitous Sensor Network (USN) est un réseau conceptuel construit sur des réseaux physiques existants. Il se sert des données détectées et fournit des services de connaissances à quiconque, n'importe où, à tout moment des dispositifs et des USN. portables intelligents émergent rapidement en offrant de nombreux services fiables facilitant la vie des gens. Ces petits terminaux très utiles ont besoin d'un substrat de communication globale pour fournir un service complet à l'utilisateur final. En 2010, ITU-T a fourni les exigences pour supporter des applications et des services USN dans l'environnement Next Generation Network (NGN) afin d'exploiter les avantages de ce réseau. L'un des principaux marchés prometteurs pour l'application et les services USN est la e-santé. Ce marché fournit le suivi des patients en continu et permet une grande amélioration dans les services médicaux. D'autre part, la technologie Véhicules Ad-hoc Network (VANET) permet d'établir une communication intelligente entre les véhicules mobiles. Intégrer VANET avec USN permettra d'améliorer la sécurité routière et la fluidité du trafic. La plupart des applications VANET sont liées à des contraintes élevées du temps réel, en particulier celles liées à la sécurité et à la santé.

Dans ce travail, nous proposons d'utiliser l'IP Multimédia Subsystem (IMS) comme une souscouche de contrôle de service dans l'environnement USN afin de fournir un substrat mondiale pour un service complet de bout en bout. De plus, nous vous proposons d'intégrer VANETs avec USN ce qui facilitera la vie des humains. Nous avons commencé par l'étude des défis pour atteindre cet objectif.

Tout d'abord, le réseau de capteurs souffre de capacités limitées telles que la bande passante, la faible puissance de traitement et la taille de la mémoire. Il existe donc un besoin a concevoir des protocoles qui échangent des données à sink avec une méthode efficace pour évites la haute consommation d'énergie. L'une de ces techniques recueille les données de capteurs dans un petit paquet de taille appropriée pour la transmission. Nous proposons dans cette thèse un nouveau protocole d'agrégation des données (DAP) pour réduire la consommation d'énergie dans les réseaux de capteurs sans fil (WSN), ce qui prolonge la durée de vie du réseau. Ce protocole utilise une approche d'agrégation afin de distribuer le traitement sur tout le chemin. Cette approche permet d'éviter la consommation d' déséquilibrée d'énergie entre des nœuds spécifiques. A partir des résultats de simulation, DAP permet d'obtenir une performance supérieure

et réalise un niveau intéressant de consommation d'énergie, et permet par conséquent détendre la durée de vie du réseau.

Deuxièmement, nous avons développé une architecture détaillée du réseau (USN base sur IMS) pour la mise en œuvre du service e-santé proposé. Notre solution est simple, flexible, et ne nécessite pas beaucoup de modifications dans les réseaux de communication déjà établies. Nous avons fourni un organigramme détaillé de signalisation de réseau pour différents scénarios e-santé applicables en utilisant Session Initiation Protocol (SIP). Nous avons proposé la modification du protocole SIP pour correspondre aux caractéristiques prévues dans le service e-santé proposé. En outre, nous avons proposé la détection des cas d'urgence, ce qui est pratiquement indispensable pour sauver la vie des patients. L'évaluation de la proposition prouve la capacité d'implémenter les scénarios e-santé proposés et la fiabilité du nouveau modèle de signalisation.

Enfin, comme les applications de VANET sont appliqués en temps réel et ils sont sensibles au retard, en particulier les applications liés à la sécurité et à la santé. La vérification de la bonne performance de l'application proposée est très important. Une façon d'y parvenir consiste à calculer le cycle de Trip Time (RTT), qui est le temps pris par une application VANET pour envoyer un message en partant du noeud initiateur (véhicule source) jusqu'à la réception d'une réponse du réseau d'infrastructure. Dans cette partie, nous présentons un nouveau modèle analytique complète pour calculer la RTT des applications VANET. En outre, nous introduisons une nouvelle architecture de réseau détaillée pour les applications VANET en utilisant IMS en tant que contrôleur de service dans l'environnement USN. A notre connaissance, il n'ya pas de travail publié précédente qui a étudiée le RTT des applications VANET ou qui a développé une architecture complète pour la mettre en œuvre en intégrant VANETs avec USNs et IMS. Le RTT est calculé en combinant deux modèles analytiques. Le premier modèle analytique sert à calculer le temps nécessaire à la communication entre deux noeuds sur une route. Le deuxième modèle utilise Baskett Chandy Muntz Palacios (BCMP), réseau des files d'attente pour les serveurs IMS, afin de calculer le temps d'exécution de l'application dans le réseau de base. Ces modèles sont suffisamment générales pour être appliquées à n'importe quelle application VANET. L'évaluation des performances du modèle développé prouve sa validité et sa précision par rapport aux résultats de la simulation.



---

En conclusion, nous pensons que les différentes contributions proposées dans cette thèse permettront d'améliorer le substrat de communication mondiale nouvelle afin d'avoir des applications plus utiles pour la vie humaine en se basant sur notre architecture. De plus, nos modèles mathématiques proposés enrichiront la littérature en termes de construction de modèles appropriés pour évaluer les réseaux complexes de bout en bout.

**Mots-clés:** Mots-clés: Réseaux des capteurs, WSN, Réseau des Nouvelles Générations, IP Multimedia Subsystem, Session Initiation Protocol, réseaux véhiculaire.

## Thesis Publications

### Journal Papers

- Adel Mounir Said, Ashraf William Ibrahim, Hossam Afifi, “**Modeling Interactive Real-Time Applications in VANETs with Performance Evaluation,**” *submitted to IEEE Transaction on Vehicular Technology.*
- Adel Mounir Said, Hossam Afifi, “**On the Shortest Path in Vehicular Networks,**” *submitted to Elsevier Journal (Performance Evaluation).*

### Conference Papers

- Adel Mounir Said, Ashraf William Ibrahim, “**Evaluation of the New e-Health Signaling Model in the Ubiquitous Sensor Network Environment,**” *accepted in the Ninth International Conference on Systems and Networks Communications (ICSNC 2014), Nice-France, 2014.*
- Adel Mounir Said, Ashraf William Ibrahim, Ahmed Soua, Hossam Afifi, “**Dynamic Aggregation Protocol for Wireless Sensor Networks,**” *IEEE 27th International Conference on Advanced Information Networking and Applications (AINA 2013), Barcelona-Spain, doi: 10.1109/AINA.2013.44, March 2013, pp. 356 – 361.*
- Adel Mounir Said, Ashraf William Ibrahim, “**NEW e-Health Signaling Model in the NGN Environment,**” *IEEE 14<sup>th</sup> International Conference on e-Health Networking, Application & Services (HEALTHCOM 2012), Beijing-China, doi: 978-1-4577-2038-3/12, Oct 2012, pp. 391 – 394.*
- Emad Abd-Elrahman, Adel Mounir Said, Thouraya Toukabri-Gunes, Hossam Afifi, “**A Hybrid Model to Extend Vehicular Intercommunication V2V through D2D Architecture,**” *Accepted in the International Conference on Computing, Networking and Communications (ICNC 2014).*
- Thouraya Toukabri-Gunes, Adel Mounir Said, Emad Abd-Elrahman, Hossam Afifi, “**Cellular Vehicular Networks (CVN): ProSe-based ITS in advanced 4G networks**”, *Accepted in the 11<sup>th</sup> IEEE International Conference on Mobile Ad hoc and Sensor Systems (IEEE MASS 2014).*

- Emad Abd-Elrahman, Adel Mounir Said, Thouraya Toukabri-Gunes, Hossam Afifi, “**Assisting V2V Failure Recovery Using Device to Device Architectures,**” Accepted in *Wireless Days (WD’14)*.

### **Research Reports**

- Adel Mounir Said, Hossam Afifi, “**On the Shortest Path in Vehicular Technology,**” *Research Report Telecom SudParis 14001-RST, 2014.*

## **Acknowledgement**

First, I would like to Thank God. Without his care and blessings, I would not achieve any progress. Many thanks to my supervisor Prof. Hadia Said El-Hennawy, Ain Shams University, for her guidance and the many constructive suggestions during the PhD study. I would like to express my deep gratitude and gratefulness to Prof Hossam Afifi, Telecom SudParis, for his trusting on me. He was lighting the way by his help and ideas. Also, I would like to thank Dr. Ashraf William Ibrahim, National Telecommunication Institute, for his sincere help and time, he was always giving a strong support and encourage to me. I consider myself lucky by my supervisors' board.

Warmest thanks to my department head, Prof. Amani Sabri Amin, National Telecommunication Institute, she was always encouraging and supporting me especially at the hard times during this work. Really, words cannot satisfy what she made for me.

I wish to thank also the members of the thesis jury board for accepting the invitation and their valuable time and feedback. My special appreciation to Prof. Guy Pujolle, Prof. Michel Marot, Prof. Mohamed Abo El-Dhab, and Dr. Hassnaa Moustafa.

Second, I am grateful to my friends and colleagues in the National Telecommunication Institute and Telecom SudParis who were always offering their help and made to finish this work. Warmest thanks to Emad Abd Elrahman, Hussien Harb, Ahmed Soua, Khalifa Toumi, and Mohamed Khedher for their kind help.

This work came to light by their help, support, and encourage. I'm lucky to have them behind me.

*This work is dedicated to my angel David, my lovely wife Miral, my  
parents, and my brothers Remon & Simon  
You gave me love and support  
I hope my achievement would draw a smile on your faces  
Thanks My Precious Family*

*Adel Mounir Sareh Said*

# List of Contents

---

<b>Abstract</b> .....	<b>I</b>
<b>Résumé</b> .....	<b>IV</b>
<b>Thesis Publications</b> .....	<b>VII</b>
<b>Acknowledgement</b> .....	<b>IX</b>
<b>Chapter 1</b>	
<b>Introduction</b>	
1.1 Motivation.....	1
1.2 Contributions.....	2
1.3 Thesis Organization .....	4
<b>Chapter 2</b>	
<b>USN &amp; IMS: Bottom to Up Background</b>	
2.1 Introduction .....	6
2.2 Ubiquitous Sensor Network (USN).....	6
2.3 WSN Architecture and Protocol Stack.....	8
2.4 Routing Challenges and Design Issues in WSNs.....	10
2.5 Vehicular Ad-hoc NETWORK (VANET).....	13
2.5.1 VANET Characteristics .....	14
2.5.2 VANET Applications.....	15
2.5.3 VANET Architecture and Related Protocols .....	16
2.6 Next Generation Network (NGN).....	18
2.7 The IP Multimedia Subsystem (IMS) .....	19
2.7.1 IMS Access Independence .....	20
2.7.2 IMS Architecture.....	21
2.7.3 The Core IMS in 3GPP .....	24
2.8 Conclusion.....	26
<b>Chapter 3</b>	
<b>A Proposed Dynamic Aggregation Protocol (DAP) for Wireless Sensor Networks</b>	
3.1 Introduction .....	27
3.2 Challenges of Data Routing in WSN .....	29
3.3 Related Works .....	31
3.4 DAP: Dynamic Aggregation Protocol.....	33

---

3.4.1 Algorithm Description .....	33
3.4.2 Data Recovery .....	38
3.5 Performance Evaluation .....	40
3.5.1 Simulation Network Model .....	40
3.5.2 Simulation Results and Analysis .....	42
3.6 Conclusion .....	49
<b>Chapter 4</b>	
<b>New e-Health Signaling Model in the USN Environment</b>	
4.1 Introduction .....	50
4.2 Benefits of IMS .....	51
4.3 Related Work .....	53
4.4 Proposed Network and Service Architecture .....	54
4.5 Signaling Scenarios .....	57
4.5.1 Initialization and Registration .....	58
4.5.2 First Scenario (Periodic Transmissions) .....	61
4.5.3 Second Scenario (Emergency Case) .....	62
4.5.4 Third Scenario .....	63
4.5.5 Fourth Scenario .....	65
4.6 Potential Applications .....	66
4.7 Performance Evaluation .....	66
4.8 Conclusion .....	73
<b>Chapter 5</b>	
<b>On the Shortest Path in Vehicular Network</b>	
5.1 Introduction .....	75
5.2 Related Work .....	77
5.3 VANET Link Connectivity Model .....	78
5.3.1 Model and Assumptions .....	78
5.3.2 The Inter-distance Process .....	79
5.3.3 Recall on the Results of Liu and Shi in [82] used in [70] .....	81
5.3.4 Problem Formulation .....	82
5.3.5 Problem Solution .....	83
5.3.6 V2V Multi-Segment Model .....	85
5.4 V2V Link Model Validation .....	86
5.5 Conclusion .....	93

**Chapter 6****Modeling Interactive Real-Time Applications in VANETs with Performance****Evaluation**

6.1 Introduction .....	95
6.2 Related Work.....	97
6.3 Application Framework.....	98
6.3.1 The Architecture Model .....	98
6.3.2 The VANET Communication Model.....	100
6.4 IMS Performance Modeling.....	103
6.5 Performance Evaluation .....	108
6.5.1 IMS Queuing Modeling Validation .....	108
6.5.2 RTT Calculations .....	110
6.6 Conclusion.....	112

**Chapter 7****Conclusions & Future Work**

7.1 Thesis Conclusion .....	114
7.2 Future Work .....	115

**References..... 116****Appendix A: Demonstration of Theorem 2 (Chapter 5) ..... 125****Appendix B: Demonstration of Lemma 2 (Chapter 5) ..... 129****Appendix C: Résumé de Thèse ..... 132**

C.1 Introduction générale.....	132
C.2 Analyses des contributions de la thèse .....	134
C.2.1 DAP: Protocole d'agregation dynamique de capteurs Sans Fil .....	135
C.2.1.1 Description de l'algorithme .....	135
C.2.1.2 Comparaison de DAP avec l'agrégation de données basée sur un apprentissage par automates.....	137
C.2.1.3 Évaluation de performances .....	138
C.2.2 Nouveau modelé la signalisation pour la santé en environnement NGN .....	141
C.2.2.1 Projet de réseau et des architecture de services.....	142
C.2.2.2 Scénarios de signalisation .....	142
C.2.2.3 Évaluation de performances .....	143



---

C.2.3 Modélisation interactive d'applications temps réel dans les VANETs et évaluation de performances.....	146
C.2.3.1 Le modèle de communication VANET .....	147
C.2.3.2 Évaluation de Performances .....	148
C.3 Conclusion.....	149
<b>Appendix D: List of Acronyms .....</b>	<b>151</b>

---

## List of Figures

Figure 2.1: Sensor nodes scattered in a sensor field [14] .....	9
Figure 2.2: Overview of VANETs.....	13
Figure 2.3: The ITS architecture [21] .....	17
Figure 2.4: WAVE architecture [24] .....	18
Figure 2.5: IMS access independence.....	20
Figure 2.6: IMS functional entities [32] .....	21
Figure 2.7: Core IMS [36] .....	25
Figure 3.1: Schematic layers of USN [1].....	29
Figure 3.2: DAP Flow Chart.....	34
Figure 3.3: Data recovery. (a) Source node data received correctly, (b) 2nd winner relays source node data, (c) Source node send its corrupted data again.....	39
Figure 3.4: Network model with 100 sensor nodes .....	40
Figure 3.5: Link connections between neighbors .....	41
Figure 3.6: The aggregation ratio for the three algorithms .....	43
Figure 3.7: Power consumption per node .....	44
Figure 3.8: Total power consumption for each algorithm .....	45
Figure 3.9: Total power consumption for each algorithm with respect to the same number of aggregated data messages .....	45
Figure 3.10: Network lifetime.....	46
Figure 3.11: Aggregation time with respect to the packet size.....	47
Figure 3.12: Comparison between the aggregation capabilities of the three algorithms in case of different similar nodes percentage .....	48
Figure 4.1: Next generation e-Health network architecture.....	55
Figure 4.2: Proposed SIP “Message” request body for e-Health services.....	57
Figure 4.3: Registration and initialization scenario .....	60
Figure 4.4: Periodic transmission scenario .....	62
Figure 4.5: Emergency scenario .....	63
Figure 4.6: Uploading patients’ files using an IMS client.....	64
Figure 4.7: Uploading patients’ file(s) directly through the WS .....	65
Figure 4.8: Changing in the patients database/uploading files through the WS .....	66
Figure 4.9: Network architecture built using the OPNET simulation tool .....	67
Figure 4.10: ACE whiteboard model for the registration and initialization signaling flow.....	68
Figure 4.11: The registration time at different connection speeds.....	69
Figure 4.12: The emergency detection time at different connection speeds.....	70
Figure 4.13: File uploading time at different number of users .....	71
Figure 4.14: File uploading time at different connection speeds.....	72
Figure 4.15: The effect of uploading files scenario on the registration scenario.....	72
Figure 4.16: The effect uploading files scenario on periodic data transmission scenario .....	73

Figure 5.1: Vehicles connected component according to the shortest path .....	80
Figure 5.2: V2V link model .....	86
Figure 5.3: Comparison of number of hops of different road lengths at a transmission range (R = 150m) and the vehicle speed = 100Km/h .....	87
Figure 5.4: Comparison of number of hops of different road lengths at a transmission range (R = 200m) and the vehicle speed = 100Km/h .....	88
Figure 5.5: Comparison of number of hops of different road lengths at a transmission range (R = 300m) and the vehicle speed = 100Km/h .....	88
Figure 5.6: Comparison of number of hops of different road lengths at a transmission range (R = 350m) and the vehicle speed = 100Km/h .....	89
Figure 5.7: Comparison of number of hops of different road lengths at a transmission range (R = 450m) and the vehicle speed = 100Km/h .....	89
Figure 5.8: Comparison of number of hops of different road lengths at a transmission range (R = 500m) and the vehicle speed = 100Km/h .....	90
Figure 5.9: Comparison of number of hops of different transmission ranges (R =150, 300, and 450m) at distance between the event initiator vehicle and the nearest RSU (L= 3Km) and the vehicles speed = 100 Km/h .....	91
Figure 5.10: Comparison of number of hops of different transmission ranges (R =200, 350, and 500m) at distance between the event initiator vehicle and the nearest RSU (L= 3Km) and the vehicles speed = 100 Km/h .....	91
Figure 5.11: The delay comparison of different vehicle density at different transmission ranges (R = 200, 350, and 500m) at distance between the vehicle that detects the event and the nearest RSU (L = 3Km). .....	93
Figure 5.12: The delay comparison of different vehicle density at different transmission ranges (R = 200, 350, and 500m) at distance between the vehicle that detects the event and the nearest RSU (L = 3Km) .....	93
Figure 6.1: Next generation VANET network architecture .....	99
Figure 6.2: Proposed application signaling flow .....	102
Figure 6.3: Queuing model for the proposed architecture .....	106
Figure 6.4: Calculations of arrival rate for each server .....	107
Figure 6.5: The processing time of VANET applications on the IMS servers .....	110
Figure 6.6: Round Trip Time comparison between the analytical and simulation results of the proposed VANET application at (L = 2km) .....	111
Figure 6.7: Round Trip Time comparison between the analytical and simulation results of the proposed VANET application at (L = 3km) .....	112
Figure 6.8: Round Trip Time comparison between the analytical and simulation results of the proposed VANET application at (L = 4km) .....	112
Figure C.1: Taux d'agrégation pour les trois algorithmes .....	139
Figure C.2: Consommation d'énergie totale pour chaque algorithme .....	140
Figure C.3: Comparaison entre les capacités d'agrégation des trois algorithmes pour différents pourcentage le nœuds similaires .....	140
Figure C.4: Prochaine génération d'architecture de réseau d'e-santé .....	142
Figure C.5: Le temps d'enregistrement à différentes vitesses de connexion .....	144
Figure C.6: Le temps de détection d'urgence à différentes vitesses de connexion ....	145

---

Figure C.7: Temps de téléchargement de fichier pour différents nombres d'utilisateurs .....	146
Figure C.8: Flux de signalisation de demande dans l'IMS .....	148
Figure C.9: Comparaison du temps aller/retour entre les résultats d'analyse et ceux de simulation pour l'application sur la partie VANET à (L = 2km).....	149

---

## List of Tables

---

Table 3.1: Typical Sensors' Radio Operating Conditions .....	42
Table 4.1: IMS entities processing and transmission times.....	68
Table 4.2: Uploaded Files Sizes.....	70
Table 4.3: HSUPA Categories Speed .....	71
Table 5.1: IEEE 802.11p Mac Access Delay.....	92
Table 6.1: IMS Servers Parameters Used .....	109
Table 6.2: Average Processing Time of VANET Application in the IMS Network .	109

---

# Chapter 1

## Introduction

*“Communication, along with information, is a source of power”*

(Castells, 2007, p. 238)

### 1.1 Motivation

Information is the corner stone of building most of the knowledge services nowadays. The Ubiquitous Sensor Network (USN) is a data mine providing information to anyone, anywhere, and at any time [1]. USN utilizes wireline Sensor Networks (SNs) and/or Wireless Sensor Networks (WSNs), which is the most common. In recent few years, various types of WSNs have been deployed and the amount of information generated by wireless sensors increased rapidly. First, data storage volumes grow more than 50% annually [2]. Therefore, this information explosion requires establishing novel data aggregation and processing algorithms in order to decrease the volume of the received data messages from such networks. Furthermore, reducing the number of received data messages alleviates the load expected on the core network.

Second, current telecommunication trends try to converge all the types of services into one common architecture [3]. The main objective is to converge all services types under one umbrella called the Next Generation Network (NGN) [4]. The general idea behind the NGN is that all information is transmitted onto an all IP network, like the Internet. Packets are labeled according to their type (data, voice, etc.) and handled differently for Quality of Service (QoS) and security purposes by traffic management equipment. NGN shall provide the capabilities (infrastructure, protocols, etc.) to make the creation, deployment, and management of all kinds of services (known or not yet known) possible [5]. Services with different bandwidth (BW) demands from a few Kbit/s to hundreds of Mbit/s, guaranteed or not, should be supported within the

capabilities of the transport technologies. Within the NGN there is an increased emphasis on service customization by the service providers whereby some of them will offer their customers the possibility to personalize their own services.

One of the most important architectures resulting from the NGN services stratum is the IP Multimedia Subsystem (IMS) [6]. IMS is an architectural framework for delivering IP multimedia services. It was originally designed by the wireless standards body 3rd Generation Partnership Project (3GPP), as a part of the vision for evolving mobile networks beyond GSM. Its original formulation (3GPP Rel-5) represented an approach to deliver "Internet services" over GPRS. This vision was later updated by 3GPP, 3GPP2, and ETSI TISPAN by requiring support of networks other than GPRS, such as WLAN, CDMA2000, and fixed lines.

Finally, there is a shortage in research for the integration between USN and the IMS-based NGN. The ITU-T published in 2010 [1] the requirements of the integration between the USN and the NGN without further details. IMS as will be described in chapter 2 and 4 has many advantages and can fulfill these ITU-T requirements.

In this thesis, it is proposed to build e-health application on IMS for exploiting the rich data mine provided by the USN. Solutions for the convergence between these two networks are introduced. The proposed application is chosen to be in e-Health as individuals and public health is obviously desirable. For this objective, a new network and service architecture is proposed following the IMS-based NGN architecture and according to the requirements of the USN. Moreover, to complete the vision of providing e-Health everywhere and anytime, a safety application is proposed to be applied in the Vehicular Ad-hoc NETWORK (VANET), which could be easily converged and controlled by the proposed service architecture.

## 1.2 Contributions

The main contributions of the thesis are summarized as follows:

- **Developing a new protocol for data aggregation:** it is interesting to provide the information exploited in building safety applications in the IMS-based NGN. On one hand, the WSN suffers of many limitations such as the low capability and power. On the other hand, it is better to decrease the number of messages delivered to the IMS platform for two reasons. First, to optimize the power utilization for WSNs and hence extending its lifetime. Second, to

decrease the load expected on the core network due to the huge number of received messages. Therefore, in this contribution a new data aggregation protocol is developed that could be applied to the WSN. In addition, an intelligent data recovery mechanism is developed. The simulation results validate the superior performance of the proposed protocol compared to two other protocols as shown in chapter 3.

- **Developing & Evaluating a New e-Health Signaling Model in the USN Environment:** In 2010, the ITU-T provided the requirements to support USN applications and services in the NGN environment to exploit the advantages of the core network. One of the main promising markets for the USN applications and services is the e-Health. It provides continuous patients' monitoring and enables a great improvement in medical services. This part of the work proposes a new network and Context Awareness (CA) service architecture for e-Health services. The model is based on using the IP IMS as a service controller sub-layer for the USN platform. The work provides a USN based IMS detailed network design for e-Health implementation with emphasizes on Session Initiation Protocol (SIP) modification and middleware entities functions. It provides a detailed signaling model for different health care scenarios based on SIP. These scenarios include emergency cases and notifications that could be sent to medical centers, relatives, doctors, etc. The proposal involves modifications made to the SIP protocol to match the new e-Health features provided. Also, the evaluation of the e-Health signaling model in the USN environment is provided. The proposal evaluation was carried using OPNET Modeler for network simulation and proved its applicability and reliability.
- **Modeling Interactive Real-Time Applications in VANETs with Performance Evaluation:** Most VANET applications are applied in real time as they are sensitive to delay, especially those related to safety and health. Therefore, checking the applicability of any proposed application is very important. One way to achieve this is by calculating the Round Trip Time (RTT), which is the time taken by a VANET application starting from the initiator node (source vehicle) sending a message until receiving a response from the core network. In this part of work, a new complete analytical model is presented to calculate the RTT of VANET applications. Moreover, a novel



detailed network architecture for VANET applications is introduced using the IMS as a service controller in the USN environment. To the best of my knowledge, there is no previous published work that either studied the RTT of VANET applications or developed a complete architecture to implement them by integrating VANETs with USNs and IMS. The RTT is calculated by combining two analytical models. Firstly, an analytical model is developed to calculate the time needed for the communication between two nodes on a road. Secondly, a queuing model using Baskett Chandy Muntz Palacios (BCMP) queuing network is developed for the IMS servers to calculate the application's execution time in the core network. These models are general enough to be applied to any VANET application. Finally, to assess the validity and the accuracy of the proposed architecture and models, three different tools are used: C++, Matlab, and OPNET. The analytical results were compared to the simulation results to evaluate their consistency.

### **1.3 Thesis Organization**

This thesis has three contributions organized into seven chapters as follows. In chapter 2, a general bottom up background is given for USN and IMS. In that chapter, the challenges behind the USN and the advantages of the IMS are demonstrated.

In chapter 3, the developed data aggregation protocol is presented. The chapter demonstrates the challenges of routing in the WSN and overviews the related works followed by a detailed description of the proposed algorithm and a new data recovery mechanism. Moreover, the performance evaluation of the DAP protocol, and the contribution conclusion are presented in details.

Chapter 4 introduces the architecture of the new proposed network. This chapter indicates why IMS is used as the platform and the controller of the proposed application. It also contains a review of the related work for using the IMS in the USN environment. A detailed signaling flow of four proposed emergency case scenarios are presented. A modification of the SIP protocol based on proposed emergency scenarios are presented. It contains also the performance evaluation of this work using OPNET Modeler 14.0.

In chapter 5, a novel analytical model for the link connectivity in VANET is described. A review of related work is presented. Finally, the model performance

validation is illustrated by comparing the results of the simulation and analytical results carried out using Matlab 2013 and C++.

In chapter 6, an interactive real-time application in VANETs is proposed. The layered architecture of the network model is presented. A review of related work of integrating USN and VANET network using the IMS as a service controller sub-layer is investigated. A novel analytical modeling of the IMS network performance is developed. Finally, the model validity and the calculations of the RTT average values are illustrated using OPNET Modeler 14.0, Matlab 2013, and C++.

Finally, chapter 7 concludes the thesis works with a discussion of open issues and future work. This is followed by the appendixes section contains a needed proof of some theorems and lemmas of the analytical model of VANET, and a list of abbreviations.

## Chapter 2

### USN & IMS: Bottom to Up Background

#### Contents

---

<b>2.1 Introduction.....</b>	<b>6</b>
<b>2.2 Ubiquitous Sensor Network (USN) .....</b>	<b>6</b>
<b>2.3 WSN Architecture and Protocol Stack.....</b>	<b>8</b>
2.3.1 IEEE 802.15.4 WPAN .....	9
<b>2.4 Routing Challenges and Design Issues in WSNs .....</b>	<b>10</b>
<b>2.5 Vehicular Ad-hoc NETWORK (VANET).....</b>	<b>13</b>
2.5.1 VANET Characteristics.....	14
2.5.2 VANET Applications.....	15
2.5.3 VANET Architecture and Related Protocols .....	16
<b>2.6 Next Generation Network (NGN).....</b>	<b>18</b>
<b>2.7 The IP Multimedia Subsystem (IMS).....</b>	<b>19</b>
2.7.1 IMS Access Independence.....	20
2.7.2 IMS Architecture .....	21
2.7.3 The Core IMS in 3GPP.....	24
<b>2.8 Conclusion.....</b>	<b>26</b>

---

#### 2.1 Introduction

In this chapter, an overview of the technologies involved in the USN – NGN integration proposed in this thesis is presented. A review of USN is introduced. The WSN, its architecture, protocol stack, and constraints are explained showing the main challenges of the WSN routing protocols. Additionally, VANETs along with their basic protocols and applications are reviewed. Moreover, the requirements of the NGN as well as its standardization and architecture are described focusing on the IMS architecture, functions, and benefits.

#### 2.2 Ubiquitous Sensor Network (USN)

SN is a group of specialized transducers with a communications infrastructure intended to monitor and record conditions at diverse locations. A SN consists of

multiple detection stations called sensor nodes, each of which is small, lightweight and portable. Every sensor node is equipped with a transducer, microcomputer, transceiver and power source. The transducer generates electrical signals based on sensed physical effects and phenomena. The microcomputer processes and stores the sensor output. The transceiver, which can be hard-wired or wireless, receives commands from a central computer and transmits data to that computer. The power for each sensor node is derived from the electric utility or from a battery.

The term “ubiquitous” is derived from the Latin word *ubique* meaning “everywhere” [7]. However, the literal interpretation of a USN means sensors on every single part of the globe.

USN is a conceptual network built over existing physical networks. It transmits sensed data and provides knowledge services to anyone, anywhere and at any time, and where the data is generated by using context awareness [1]. SN is recognized to be a key technology for building an ubiquitous system. Using mostly wireless infrastructure, ubiquitous technologies are supposed to interface the physical environment in various circumstances such as military, home, working, health, industry, etc. This makes implementation of the ubiquitous sensing highly application-specific. USN utilizes wireline SNs and/or WSNs.

WSN consists of a group of self-organizing, lightweight sensor nodes that are used to cooperatively monitor physical or environmental conditions. Commonly monitored parameters include temperature, sound, humidity, vibration, pressure and motion [8]. Each sensor node in a WSN is equipped with a radio transmitter, several sensors, a battery unit and a microcontroller. Although WSN research was initially motivated by military applications, WSNs are now used in many industrial and public service areas including traffic monitoring, weather conditions monitoring, video surveillance, industrial automation, and healthcare applications [9]. Because of the size and cost constraints on sensor nodes, they are limited by energy, BW, memory, and other resources. For the support of USN applications and services, network and service functions have to be carefully designed to support the unique characteristics of SNs and their applications and services, including [1]:

- Limited capabilities of sensor nodes: limited BW, low processing power, and small memory size.
- Limited power that sensor nodes can harvest or store.

- Harsh and dynamic environmental conditions, which cause high possibility of node and link failure.
- Mobility support of sensor nodes, SNs and services: due to limited hardware capability, mobility capabilities may not be fully supported by a sensor node or a SN.
- Dynamic network topology: SNs often dynamically change the topologies due to the association and de-association of sensor nodes.
- High possibility of communication failures (e.g. due to low BW or link failure).
- Heterogeneity of nodes: a USN application or service may be built using more than one SN, where sensor nodes use different PHY/MAC layers or operate differently in Internet Protocol based (IP-based) or non-IP based networks.
- Large scale of deployment: a USN application or service can be deployed on a wide geographical.

### 2.3 WSN Architecture and Protocol Stack

The sensor nodes are usually scattered in a sensor field as shown in Fig. 2.1. Data are routed to the end-users by a multi-hop infrastructureless architecture through the sink/gateway. Each of these scattered sensor nodes has the capability to collect data and route it back to the sink/gateway and the end-users. In WSNs, the sensor nodes have the dual functionality of being both data originators and data routers. Hence, communication is performed for two functions:

- **Source function:** Source nodes with event information perform communication functionalities in order to transmit their packets to the sink.

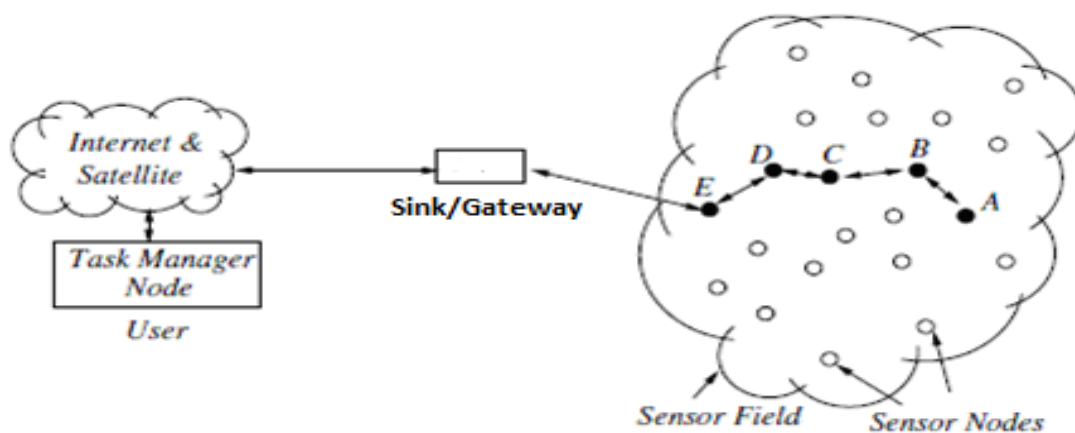
**Router function:** Sensor nodes also participate in forwarding the packets received from other nodes to the next destination in the multi-hop path to the sink.

A WSN application or service may be built using more than one SN, where sensor nodes use different PHY/MAC ([10] [11]) layers or operate differently in IP-based or non-IP based networks.

The IEEE 802.15 is a working group for Wireless Personal Area Network (WPAN) communication [12]. This group defined three classes of WPANs that are differentiated by data rate, battery drain, and QoS as follows:

- High data rate WPANs (IEEE 802.15.3) [11]: which are suitable for multimedia applications that require very high QoS.

- Medium data rate WPANs (IEEE 802.15.1)[13]: which handle a variety of tasks ranging from cell phones to Personal Digital Assistants (PDA) communications and have a QoS suitable for voice communication.
- Low data rate WPANs (IEEE 802.15.4/LR-WPAN)[10]: which are intended to serve a set of industrial, residential, and medical applications with very low power consumption and relaxed needs for data rate and QoS. The low data rate enables the LR-WPAN to consume very little power. This feature allows small, power-efficient, inexpensive solutions to be implemented for a wide range of devices.



**Figure 2.1:** Sensor nodes scattered in a sensor field [14]

The IEEE 802.15.4 standard is a simple packet data protocol for lightweight wireless networks and specifies the Physical (PHY) and Medium Access Control (MAC) layers for multiple radio frequency bands, including 868 MHz, 915 MHz, and 2.4GHz [12].

The main objectives of the IEEE 802.15.4 standard are ease of installation, reliable data transmission, short-range operation, extremely low cost, and a reasonable battery lifetime, while maintaining a simple and flexible protocol.

The three license-free frequencies of the IEEE 802.15.4 standard include sixteen channels at 2.4 GHz, ten channels at 915 MHz, and one channel at 868 MHz, to support global or regional deployment. The maximum data rates for each band are 250 kbps, 40 kbps, and 20 kbps respectively. The air interface is Direct Sequence Spread Spectrum (DSSS) using Binary Phase Shift Keying (BPSK) for 868 MHz and 915 MHz and Offset-Quadrature Phase Shift Keying (OQPSK) for 2.4 GHz [8].

Other features of the IEEE 802.15.4 PHY include receiver energy detection, link quality indication, and clear channel assessment. Both contention-based and contention-free channel access methods are supported. Maximum packet size is 133 bytes, including a variable payload of up to 127 bytes. IEEE 802.15.4 employs 64-bit IEEE and 16-bit short addresses.

### **Physical (PHY) layer**

The PHY service enables the transmission and reception of PHY Protocol Data Units (PPDU) across the physical radio channel. The features of the IEEE 802.15.4 PHY are activation and deactivation of the radio transceiver, Energy Detection (ED), Link Quality Indication (LQI), channel selection, Clear Channel Assessment (CCA) and transmitting as well as receiving packets across the physical medium.

### **Media Access Control (MAC) Layer**

The MAC service enables the transmission and reception of MAC Protocol Data Units (MPDU) across the PHY data service. The features of MAC sub layer are beacon management, channel access, Guaranteed Time Slot (GTS) management, frame validation, acknowledged frame delivery, association and disassociation.

## **2.4 Routing Challenges and Design Issues in WSNs**

Despite the innumerable applications of WSNs, these networks suffer of the previously mentioned limitations. One of the main design goals of WSNs is to carry out data communication while trying to prolong the lifetime of the network and prevent connectivity degradation by employing aggressive energy management techniques. The design of routing protocols in WSNs is influenced by many challenging factors. These factors must be overcome before efficient communication can be achieved in WSNs. Some of the routing challenges and design issues that affect routing process in WSNs can be summarized as:

- **Node deployment:** node deployment in WSNs is application dependent and affects the performance of the routing protocol. The deployment can be either deterministic or randomized. In deterministic deployment, the sensors are manually placed and data is routed through predetermined paths. However, in

random node deployment, the sensor nodes are scattered randomly creating an infrastructure in an ad-hoc manner.

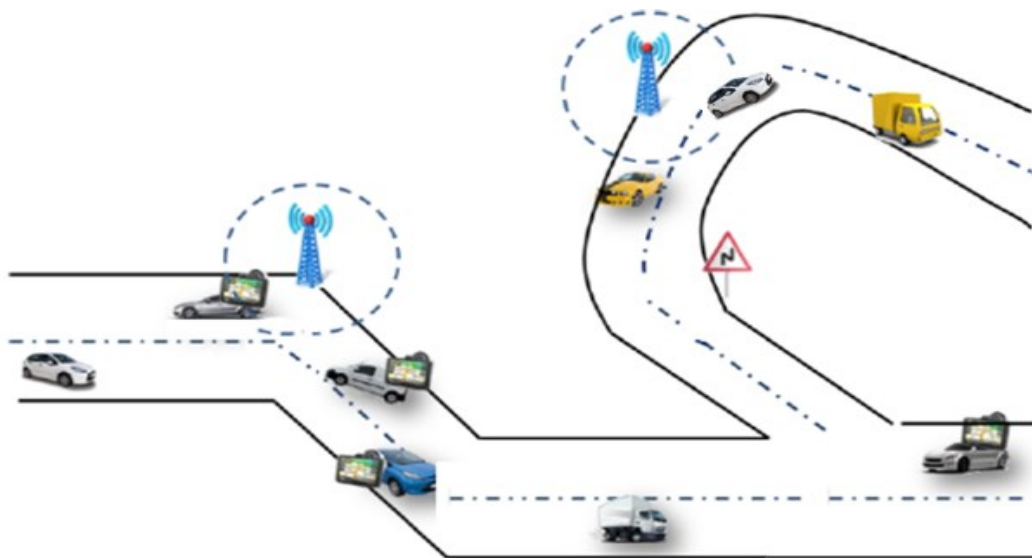
- **Energy consumption without losing accuracy:** sensor nodes can use up their limited supply of energy performing computations and transmitting data in a wireless environment. As such, energy conserving forms of communication and computation are essential. Sensor node lifetime shows a strong dependence on the battery lifetime [15]. In a multi-hop WSN, each node plays a dual role as data sender and data router. The malfunctioning of some sensor nodes due to power failure can cause significant topological changes and might require rerouting of packets and reorganization of the network.
- **Data reporting model:** data sensing and reporting in WSNs is dependent on the application and the time criticality of the data reporting. Data reporting can be categorized as either time-driven (continuous), event-driven, query-driven, and hybrid [16]. The time-driven delivery model is suitable for applications that require periodic data monitoring. As such, sensor nodes will periodically switch on their sensors and transmitters, sense the environment and transmit the data of interest at constant periodic time intervals. In event-driven and query driven models, sensor nodes react immediately to sudden and drastic changes in the value of a sensed attribute due to the occurrence of a certain event or a query is generated by a Base Station (BS). As such, these are well suited for time critical applications. A combination of the previous models is also possible. The routing protocol is highly influenced by the data-reporting model with regard to energy consumption and route stability.
- **Node/Link heterogeneity:** in many studies, all sensor nodes were assumed to be homogeneous, i.e., having equal capacity in terms of computation, communication, and power. However, depending on the application, a sensor node can have different role or capability. The existence of heterogeneous set of sensors raises many technical issues related to data routing. For example, some applications might require a diverse mixture of sensors for monitoring temperature, pressure and humidity of the surrounding environment, detecting motion via acoustic signatures, and capturing the image or video tracking of moving objects.



- **Fault tolerance:** some sensor nodes may fail or be blocked due to lack of power, physical damage, or environmental interference. The failure of sensor nodes should not affect the overall task of the SN. If many nodes fail, MAC and routing protocols must accommodate formation of new links and routes to the data collection BSs. This may require actively adjusting transmit powers and signaling rates on the existing links to reduce energy consumption, or rerouting packets through regions of the network where more energy is available. Therefore, multiple levels of redundancy may be needed in a fault-tolerant SN.
- **Scalability:** the number of sensor nodes deployed in the sensing area maybe in the order of hundreds or thousands, or more. Any routing scheme must be able to work with this huge number of sensor nodes. In addition, SN routing protocols should be scalable enough to respond to events in the environment. Until an event occurs, most of the sensors can remain in the sleep state, with data from the few remaining sensors providing a coarse quality.
- **Network dynamics:** most of the network architectures assume that sensor nodes are stationary. However, mobility of BS's or sensor nodes is sometimes necessary in many applications [17]. Routing messages from or to moving nodes is more challenging since route stability becomes an important issue, in addition to energy, BW, etc. Moreover, the sensed phenomenon can be either dynamic or static depending on the application, e.g., it is dynamic in a target detection / tracking application, while it is static in forest monitoring for early are prevention. Monitoring static events allows the network to work in a reactive mode, simply generating traffic when reporting. Dynamic events in most applications require periodic reporting and consequently generate significant traffic to be routed to the BS.
- **Transmission media:** in a multi-hop SN, communicating nodes are linked by a wireless medium. The traditional problems associated with a wireless channel (e.g., fading, high error rate) may also affect the operation of the SN. In general, the required BW of sensor data will be low.
- **Connectivity:** high node density in SNs precludes them from being completely isolated from each other. Therefore, sensor nodes are expected to be highly connected. This, however, may not prevent the network topology from being variable and the network size from being shrinking due to sensor node failures.

## 2.5 Vehicular Ad-hoc NETWORK (VANET)

VANET is a form of Mobile Ad-hoc NETWORK (MANET), in which vehicles communicate with each other and with nearby fixed roadside equipment as shown in Fig. 2.2. VANET contains two entities: access points and vehicles. The access points are fixed and are connected to the Traffic Control Center (TCC). VANET addresses the wireless communication between vehicles (V2V), and between vehicles and infrastructure access points (V2I). Vehicles are capable of communicating (wired/wireless) using an equipped device called On Board Unit (OBU). The infrastructure access points are called Road Side Units (RSUs). RSUs are connected with backbone networks. Therefore, V2I can provide real-time information on road traffic conditions, weather, and basic Internet service. The vehicular communication has two types: one hop communication (direct vehicle to the destination) and multi hop communication (vehicle relies on other vehicles to retransmit).



**Figure 2.2:** Overview of VANETs

To realize communication in VANETs, the Federal Communications Commission (FCC) dedicated 75MHz of the frequency spectrum in the range 5.850 GHz to 5.925 GHz to be used for V2V and V2I communication. The 5.9 GHz spectrum was termed Dedicated Short Range Communication (DSRC) [18] and uses IEEE 802.11p [19]. VANET applications must share the allocated BW, making it a scarce resource that should be managed very carefully. Inefficient data dissemination wastes

a large amount of BW that if saved would allow more vehicular applications to co-exist in addition to allowing the vehicular data to be disseminated further.

VANETs and USNs can be integrated together providing a new set of applications and services. Vehicles can be equipped with sensors to monitor some specific events related to the vehicles parts such as mechanical faults, liquids level, etc. or to monitor the status of the vehicles e.g. the velocity of the vehicle. Moreover, drivers could wear health sensors to monitor their physical status. All these types of sensors enrich VANET applications and can be used to provide safety on roads. Figure 2.2 shows an overview of VANETs.

### 2.5.1 VANET Characteristics

VANETs are similar to MANETs since both of them support ad-hoc communications between mobile nodes in dynamic network scenarios. Nevertheless, research studies and achievements carried out in the field of MANETs cannot be directly applied in the context of vehicular networks since these latter present unique features and specifications [20]. Here are some properties that distinguish vehicular networks:

- **High dynamic topology:** due to the highly variable speeds between vehicles and the choice of path, the network topology in VANETs tends to change frequently.
- **Frequent disconnected network:** the above feature necessitates that in about every 5 seconds or so, the nodes need another link with nearby vehicle to maintain seamless connectivity. However, in case of such failure, particularly in case of low vehicle density zone, frequent disruption of network connectivity will occur. Such problems are at times addressed by roadside deployment of relay nodes.
- **Mobility model and network distribution:** environments in ad-hoc networks are often limited to open spaces. In VANETs, the topology is dynamic but it is not completely random because the distribution of moving vehicles is generally along roads (streets, highways). In fact, mobility of vehicles is somewhat restricted by predefined roads, as well as the direction and the number of lanes.
- **Critical application requirement:** it is one of the most important property that is applications within VANETs are often safety critical and time-critical (e.g.

alert messages, warnings). Ad-hoc networks that mainly serve to distribute data do not underlie these aspects [21].

- **Auxiliary information:** nodes in VANETs are context aware. They have access to additional data such as vehicle sensor data or GPS. The usage of these so called “side-channel” information can be valuable when evaluating data obtained through communication with other nodes in the VANET [21].
- **Privacy:** in some cases, services in a VANET are related to personal data, such as current location or current speed, which requires anonymity in order to protect a driver’s privacy. On the other hand, other services require identification and traceability.

### 2.5.2 VANET Applications

There are many applications envisioned for VANETs. These applications can be organized into three major classes [22]: safety-oriented, convenience-oriented, and commercial-oriented.

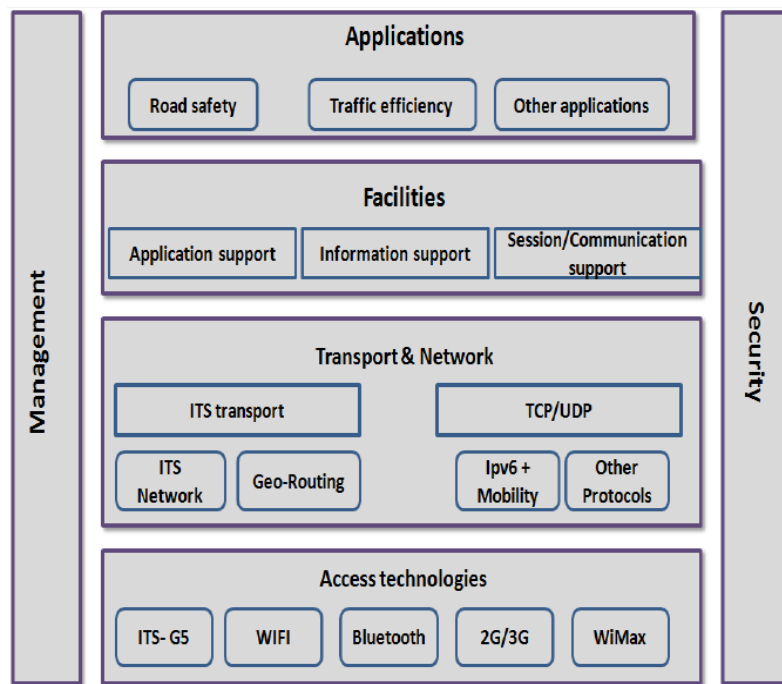
- **Safety applications:** monitors the nearby environment (the state of other vehicles or of road conditions) via message exchanges between vehicles, so that applications are able to assist drivers in handling the upcoming events or potential danger. Some applications may automatically take appropriate actions (such as automatic braking) to avoid potential accidents, while other applications aim only to provide assistance to drivers as they chose. The latter applications are very similar to the former applications, even though the system requirements (such as reliability, latency, etc.) are less stringent. However, both types of applications aim to improve the level of vehicle safety.
- **Convenience (traffic management) applications:** shares traffic information among roadway infrastructure, vehicles on the road, and centralized traffic control system, to enable more efficient traffic flow control and maximize vehicle throughput on the road. Ultimately, these applications not only enhance traffic efficiency, but also boost the degree of convenience for drivers.
- **Commercial (infotainment) applications:** provides drivers with various types of communication services to improve driver productivity, entertainment, and satisfaction, such as web access and streaming audio and video.

### 2.5.3 VANET Architecture and Related Protocols

Many organizations are involved in the standardization of vehicular communications. They are focusing on safety, traffic efficiency, and infotainment related applications. Communication architectures are usually based on the layered OSI model. For VANETs, each category of applications requires different exigencies in terms of delay, BW consumption, and QoS. For instance, safety applications [22] require strict latency and reliability requirements, while commercial applications are characterized by huge BW consumption. This variety of needs and requirements has led to proposing different new architectures offering different network access technologies, addressing schemes, and protocols.

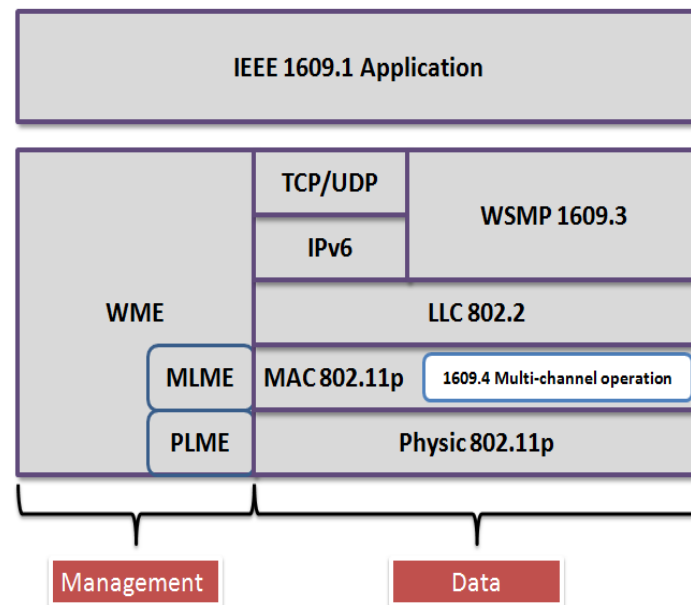
The most known and used communications standards are reviewed hereafter without getting into further details as the function of these communication protocols is out of scope.

Intelligent Transport Systems (ITS) and IEEE set the most known and used architectures for VANETs. Regarding to ITS [23], the architecture shown in Fig. 2.3 is supported and maintained by the European Telecommunications Standards Institute (ETSI) aiming at developing standards and specifications for ITS services. This framework is composed of four vertical layers (application, facilities, transportation & networking, access to medium) with two vertical planes: management and safety plans. For the network routing, ITS uses TCP/UDP and the ITS transport protocol, which is defined to support the V2V communication in a very dynamic and hostile network such as VANET. Facilities layer is a new paradigm introduced by ETSI and its main functionalities are the fusion and maintenance of different collected data. Another task supported by this block is to continuously update the geographic dynamic map, so that it can be used by applications. This map reflects the dynamic events occurring on the road.



**Figure 2.3:** The ITS architecture [21]

Regarding Wireless Access in Vehicular Environments (WAVE) [24], the IEEE 1609 Family of Standards for WAVE define an architecture and a complementary standardized set of services and interfaces that collectively enable secure V2V and V2I wireless communications. Together these standards are designed to provide the foundation for a broad range of applications in the transportation environment, including vehicle safety, automated tolling, enhanced navigation, traffic management, and many others as shown in Fig. 2.4. The architectural ideas originated from the internationally agreed standard DSRC. The focus of DSRC is on the lower layers (MAC/PHY), which are based on a modified version of the IEEE 802.11a, known as IEEE 802.11p. It is based on the CSMA/CA mechanism as the basic medium access scheme for link sharing and uses one control channel to set up transmissions and to send emergency messages.



**Figure 2.4:** WAVE architecture [24]

## 2.6 Next Generation Network (NGN)

According to ITU-T, the NGN definition is a packet-based network able to provide telecommunication services and able to make use of multiple broadband, QoS-enabled transport technologies and in which service-related functions are independent from underlying transport related technologies. It enables unfettered access for users to networks and to competing service providers and/or services of their choice. It supports generalized mobility, which will allow consistent and ubiquitous provision of services to users.

NGN functions are divided into service and transport layers (strata). The transport layer functions provide connectivity for all components and physically separated functions within an NGN. IP is recognized as the most promising NGN transport technology. Thus, the transport layer will provide IP connectivity for both end-user equipment (residing outside an NGN) and various controllers and enablers that are usually located in servers within the area of an NGN. The transport layer is responsible for providing QoS, which is a desirable feature of the NGN. The transport layer is further divided into access and core network.

NGN services will include session-based and non-session-based services. Examples of the session-based services are IP telephony and video conferencing, and examples of the non-session-based services are video streaming and broadcasting. One of the NGN service layer subsystems is the IMS.

## 2.7 The IP Multimedia Subsystem (IMS)

The IP is ubiquitous. According to the Internet Society, it is used to interconnect more than one billion people all over the world. The Internet provides interoperability at a very large scale, enabling people using different terminals to communicate. While the first generation of the Internet was mostly dedicated to the transport of non real time data, services with stringent QoS requirements are now largely adopted. Telephony over IP (ToIP), Video-conferencing, and IPTV are examples of such services. Moreover, the share of the multimedia services in the operators' revenue is expected to grow in the next few years [25].

The move toward all IP architecture for service delivery appears to be a strong trend. In this context, customers seem to desire an access to personalized interactive, multimedia services, on any device, and anywhere. This trend introduces new requirements for network infrastructures. The IMS is seen as a promising solution for fulfilling these expectations [26].

IMS refers to a functional architecture for multimedia service delivery, based upon Internet protocols [27]. Its aim is to merge Internet and cellular worlds, in order to enable rich multimedia communications [28] [29]. It was originally designed by the wireless standards body 3GPP, as a part of the vision for evolving mobile networks beyond GSM. Its original formulation (3GPP R5), in March 2003, represented an approach to delivering "Internet services" over GPRS [30]. It was later extended by the ETSI, in the scope of its work on NGNs. A standardization body of ETSI, called Telecommunications and Internet converged Services and Protocols for Advanced Networking (TISPAN) standardizes IMS as a subsystem of NGNs. It could be considered that 3GPP describes the point of view of mobile operators, while TISPAN adds the wireline operators' specifications.

To ease the integration with the Internet, IMS uses the IETF protocols wherever possible e.g. SIP. Most of the IMS protocols are standardized by the IETF. According to the 3GPP, IMS is not intended to standardize applications but rather to aid the access of multimedia and voice applications from wireless and wireline terminals, i.e. create a form of Fixed Mobile Convergence (FMC). This is done by having a horizontal control layer that isolates the access network from the service layer.

The level of QoS that can be provided in IMS networks determines the services that can be deployed in such networks. QoS delivery is therefore critical in IMS



networks. As a result, QoS management functionalities are integrated in the IMS architecture.

IMS is seen by many as a solution for network operators to be “more than bit pipes”. Indeed, it allows the network operator to play a central role in service delivery, and bundle attractive services with their basic access offer. Moreover, IMS supports the creation and deployment of innovative services by operators or third parties and therefore create new business perspectives.

### 2.7.1 IMS Access Independence

IMS makes separation between the core and access network. The separation comes from 3GPP’s original IMS definitions, i.e. from the wireless network model in which one or more radio access networks are connected to a common core network [31]. The radio access networks provide connections between terminals and services available in the core. An access network is a collection of entities providing IP transport connectivity between a user domain and a core transport network. Different sorts of access networks are distinguished based on the underlying technology, ownership or administrative partitioning. Figure 2.5 demonstrates the different types of access independent networks that the IMS can run on. These include Fixed Broadband, WLAN, GPRS, and UMTS.

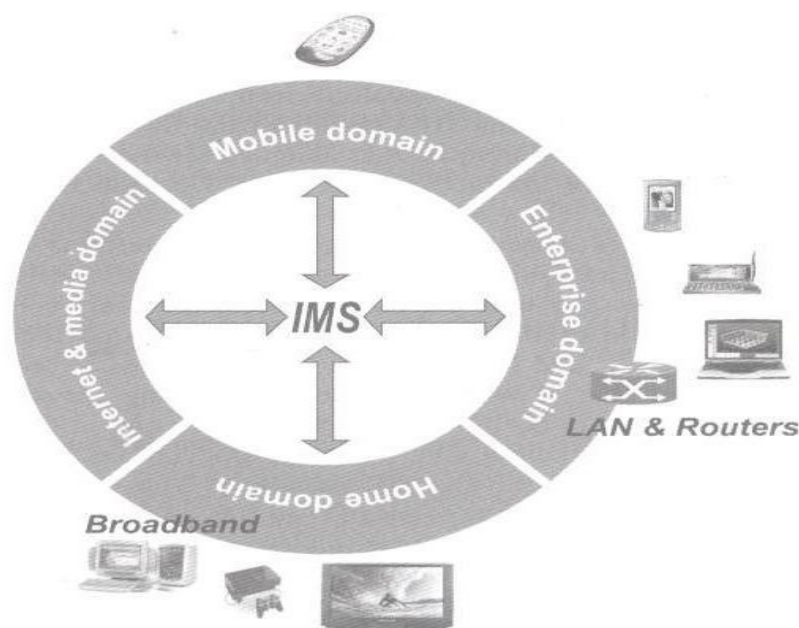


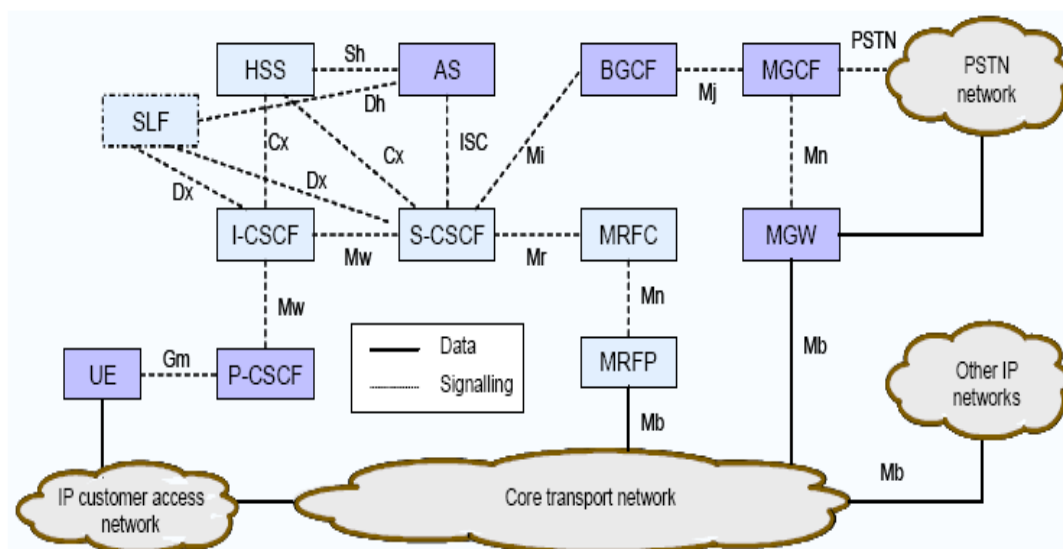
Figure 2.5: IMS access independence

IMS is intended to be “access agnostic”, which means that service delivery should be independent of the underlying access technology. The user can connect to an IMS network in various ways, all of which use the standard IP. Direct IMS terminals (such as mobile phones, PDAs, and computers) can register directly on an IMS network, even when they are roaming in another network or country (the visited network). The only requirement is that they can use IPv4 or IPv6 and run SIP user agents.

Fixed access (e.g., xDSL, cable modems, Ethernet), mobile access (e.g. LTE, W-CDMA, CDMA2000, GSM, GPRS) and wireless access (e.g. WLAN, WiMAX) are all supported. Other phone systems like plain old telephone service (POTS - the old analogue telephones), H.323 and non IMS-compatible VoIP systems, are supported through gateways.

### 2.7.2 IMS Architecture

The IP Multimedia Core Network Subsystem is a collection of different functions, linked by standardized interfaces, which grouped form one IMS administrative network. A function is not a node (hardware box): an implementer is free to combine 2 functions in 1 node, or to split a single function into 2 or more nodes. Each node can also be present multiple times in a single network, for load balancing or organizational issues. Figure 2.6 shows the collection of functional entities and reference points of the IMS functional architecture [32]. The purpose of each entity is explained shortly in the following.



**Figure 2.6:** IMS functional entities [32]

### ***a) Call Session Control Function (CSCF)***

Call Session Control Function (CSCF) is responsible for the control of session features, routing and resource allocation in cooperation with other network elements. When a SIP enabled terminal initiates a call, CSCF allocates resources and routes the SIP invite message to the called terminal. If the called side is a traditional PSTN phone number then CSCF routes SIP messages to the Breakout Gateway Control Function (BGCF). BGCF selects the Media Gateway Control Function (MGCF), which perform necessary signaling conversion. The IMS architecture supports three types of CSCFs: Serving-CSCF (S-CSCF), Interrogating-CSCF (I-CSCF) and Proxy-CSCF (P-CSCF).

S-CSCF acts as a registering function [33]. It accepts SIP register requests and creates a binding between the public user ID and the terminal location. S-CSCF retrieves the subscriber profile from the HSS, including filter criteria that indicate the ASs that offer service control to this user. To support service control, the S-CSCF interacts with these ASs during the SIP signaling. During a session establishment or modification phase, the S-CSCF monitors the Session Description Protocol (SDP) to ensure that the session is within the boundaries of the subscriber's profile.

The S-CSCF also performs routing of SIP messages [34] on behalf of the originating user equipment (UE). It obtains the address of an I-CSCF (or another IP endpoint) from a Domain Name Server (DNS) by using the destination name of the terminating subscriber. After that it forwards the SIP request toward the destination. If the destination name of the terminating subscriber is a PSTN address, the S-CSCF forwards the request to a BGCF for routing toward the PSTN. On behalf of the destination endpoint, the S-CSCF forwards the SIP request to a P-CSCF according to the subscriber's registered location, or for an unregistered subscriber it may send or redirect the SIP request to an alternate endpoint.

I-CSCF serves as the initial point of contact to the IMS home network from other networks. It performs a stateless SIP proxy function and directs received SIP requests to S-CSCF, assigned to the user, or selects an S-CSCF if one is not currently assigned. I-CSCF assigns S-CSCFs upon initial UE registration and when terminating services for unregistered users.

P-CSCF serves as the initial point of contact for a user terminal to the IMS. It performs a stateful SIP proxy function by sending SIP register requests from the UE to an I-CSCF, which resides in the home network. The home network is determined by using the home domain name, provided by the UE. The P-CSCF sends all subsequent

SIP messages, received from the UE, to the S-CSCF whose name it has received during the registration procedure. The P-CSCF also ensures that a valid public user identity of the IMS user is inserted into UE initiated SIP requests.

***b) Home Subscriber Server (HSS)***

Home Subscriber Server (HSS) contains a subscription database for the IMS. It supports IMS-level authentication and authorization as well as keeps record of the IMS subscriber profiles. The HSS also stores the currently assigned SCSCF. A home network may contain one or several HSSs. The number of HSSs depends on the number of subscribers, the capacity of the equipment and the organization of the network.

***c) Subscription Locator Function (SLF)***

SLF acts as a front-end for distributed HSS systems. It may be queried by an I-CSCF during registration and session setup to get the name of the HSS, which contains the required subscriber-specific data. The SLF may also be queried by the S-CSCF during registration or by the AS in connection with the Sh interface. The SLF is not needed in a single HSS environment or in certain other HSS environments, such as a server farm architecture.

***d) Media Gateway Control Function (MGCF)***

MGCF supports interworking between the IMS and the PSTN. MGCF performs the translation between SIP messages and Integrated Service Digital Network User Part (ISUP) messages. MGCF also controls MGW.

***e) Media Gateway (MGW)***

Media Gateway (MGW) terminates bearer channels from circuit-switched networks and media streams from packet switched networks and performs media conversion functions such as transcoding. It also offers Dual Tone Multi-Frequency (DTMF) detection and generation.

***f) Media Resource Function Controller (MRFC)***

Media Resource Function Controller (MRFC) controls Media Resource Function Processors (MRFP's) media stream resources. It interprets information from an AS or SIP endpoint and controls the MRFP accordingly to support media services

such as transcoding and conferencing. The MRFC may be co-located with an AS to support specialized AS services.

***g) Media Resource Function Processor (MRFP)***

MRFP supports functions such as media stream mixing, tone and announcement generation, transcoding and media analysis.

***h) Breakout gateway control function (BGCF)***

A BGCF receives session requests forwarded by an S-CSCF (or another BGCF) and selects the network in which a PSTN attachment point is located. It also selects a local MGCF or a peer BGCF in another network. The ability to select a BGCF in another network enables to optimize routing from a visited network to the PSTN.

***i) Application Servers (AS)***

An application server (AS) provides service control for the IMS. The AS may be directly connected to a serving call session control function (S-CSCF) or via an Open Services Architecture (OSA) gateway for third party based applications over an ISC reference point.

The ISC interface is SIP based and SIP messages may be carried over this interface to or from an S-CSCF. The AS may interact with the HSS over the Sh interface to obtain subscriber profile information. ASs are used to support various telephony-type services, e.g. call forwarding and number translation, and they may also support such services as presence, conference control and online charging.

### **2.7.3 The Core IMS in 3GPP**

As mentioned before, the core IMS is largely based on the 3GPP IMS specifications. However, the core IMS in NGN considers only SIP network elements such as CSCFs, BGCF, MGCF, and MRFC. In particular, ASs, MRFP, MGW, user databases, etc. are considered to be outside the core IMS, although they are all present in NGN either as part of the common functions or as part any of the subsystems of the transport layer.

In this section, the new functionality that has been added to the IMS due to fixed broadband access is described. Typically 3GPP has accepted changes to its IMS

specifications to adopt new functionality due to fixed broadband access, so on most occasions the latest versions of the 3GPP specifications will describe the case of accesses to IMS over broadband fixed access.

Figure 2.7 shows the core IMS architecture and the interfaces with adjacent nodes. As expected, the core IMS architecture is very similar to the 3GPP IMS architecture, due to the fact that most of the nodes are present in the core IMS. The core IMS adds new interfaces to the P-CSCF to communicate with the functional elements of the low transport layer subsystems, the RACF and NACF. The P-CSCF includes a new Gq' interface towards the RACF for the purpose of requesting authorization of QoS resources, reserving resources, and providing control of gates in the transport layer. The Gq' interface is based on the 3GPP Gq interface specified in 3GPP TS 29.209 [35]. The P-CSCF also implements a new e2 interface towards the NACF for the purpose of retrieving user's location information.

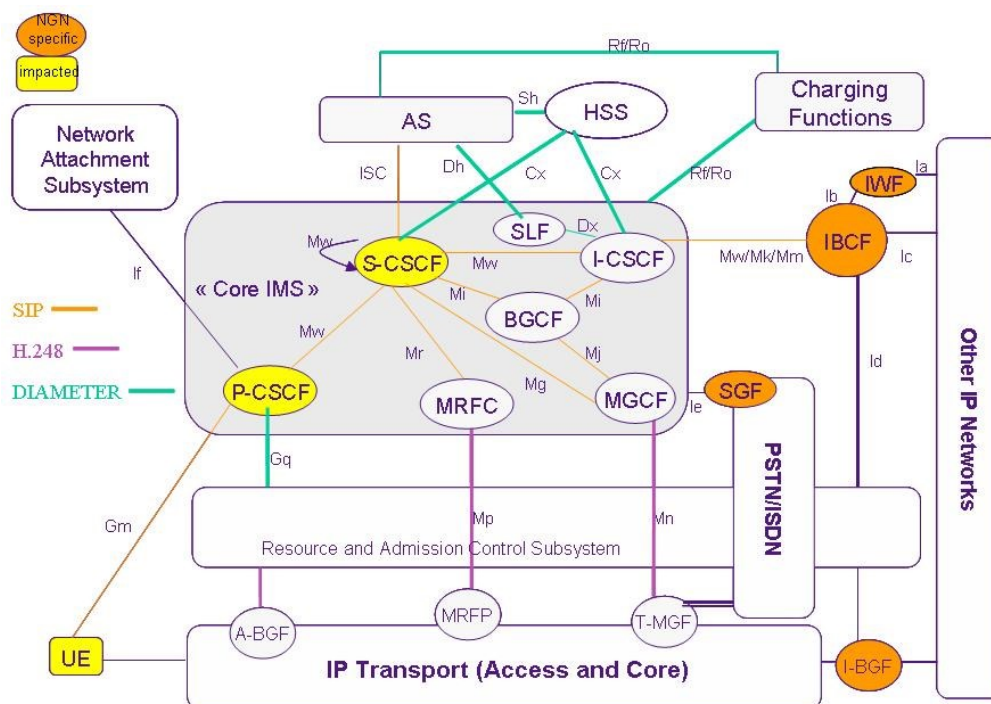


Figure 2.7: Core IMS [36]

The I-CSCF, S-CSCF, BGCF, and MRFC are the same as the IMS corresponding node. The MGCF in NGN keeps the same functionality as in the IMS, but it is complemented with additional functionality that provides an appropriate

interworking with circuit-switched networks beyond the basic call (e.g., interworking takes place even at the service level).

The Interconnection Boarder Control Function (IBCF) is a new functional entity introduced by NGN. The IBCF acts as a separation between two different domains. In doing so, it may provide functionality in case there is a need for IP version interworking. The IBCF is also responsible for inserting an Inter-Working Function (IWF) in the path when it is needed. Additionally, the IBCF may obfuscate some SIP headers that the operator may consider dangerous to expose externally.

The IWF provides interworking between SIP and other protocols (e.g., H.323). In doing so, it could potentially provide an adaptation of SIP profiles, if a need for such case is demonstrated.

## **2.8 Conclusion**

After reviewing the basic technologies used in this thesis, in chapter 3 a new data aggregation protocol in the environment of the WSN is introduced. The importance of that protocol comes from that the number of messages expected to be collected and delivered by the WSN to the IMS-based NGN is huge. Therefore, there is a need to decrease the number of these messages in order to reduce the load on the core network (IMS-based NGN).

## Chapter 3

# A Proposed Dynamic Aggregation Protocol (DAP) for Wireless Sensor Networks

### Contents

---

<b>3.1 Introduction.....</b>	<b>27</b>
<b>3.2 Challenges of Data Routing in WSN .....</b>	<b>29</b>
<b>3.3 Related Works .....</b>	<b>31</b>
3.4.1 Algorithm Description.....	33
3.4.2 Data Recovery .....	38
<b>3.5 Performance Evaluation.....</b>	<b>40</b>
3.5.1 Simulation Network Model.....	40
3.5.2 Simulation Results and Analysis.....	42
<b>3.6 Conclusion.....</b>	<b>49</b>

---

### 3.1 Introduction

In this thesis, a novel platform for new applications based on IMS/NGN exploiting the rich information provided by the WSN is proposed. The number of messages received from the WSN is expected to be myriad. This cause an overload to the system. Therefore, in this chapter, a new aggregation protocol that could alleviate the effect of this problem, and help in prolonging the WSN lifetime as well.

USN applications and services are created via the integration of SN applications and services into the network infrastructure. They are applied to everyday life in an invisible way as everything is virtually linked by pervasive networking between USN end-users (including machines and humans) and SNs, relayed through intermediate networking entities such as ASs, middleware entities, access network entities, and USN gateways. USN applications and services can be used in many civilian application areas such as industrial automation, home automation, agricultural monitoring, healthcare,



environment, pollution and disaster surveillance, homeland security, or military field. The main components of a USN, as described in Fig. 3.1 [1], are:

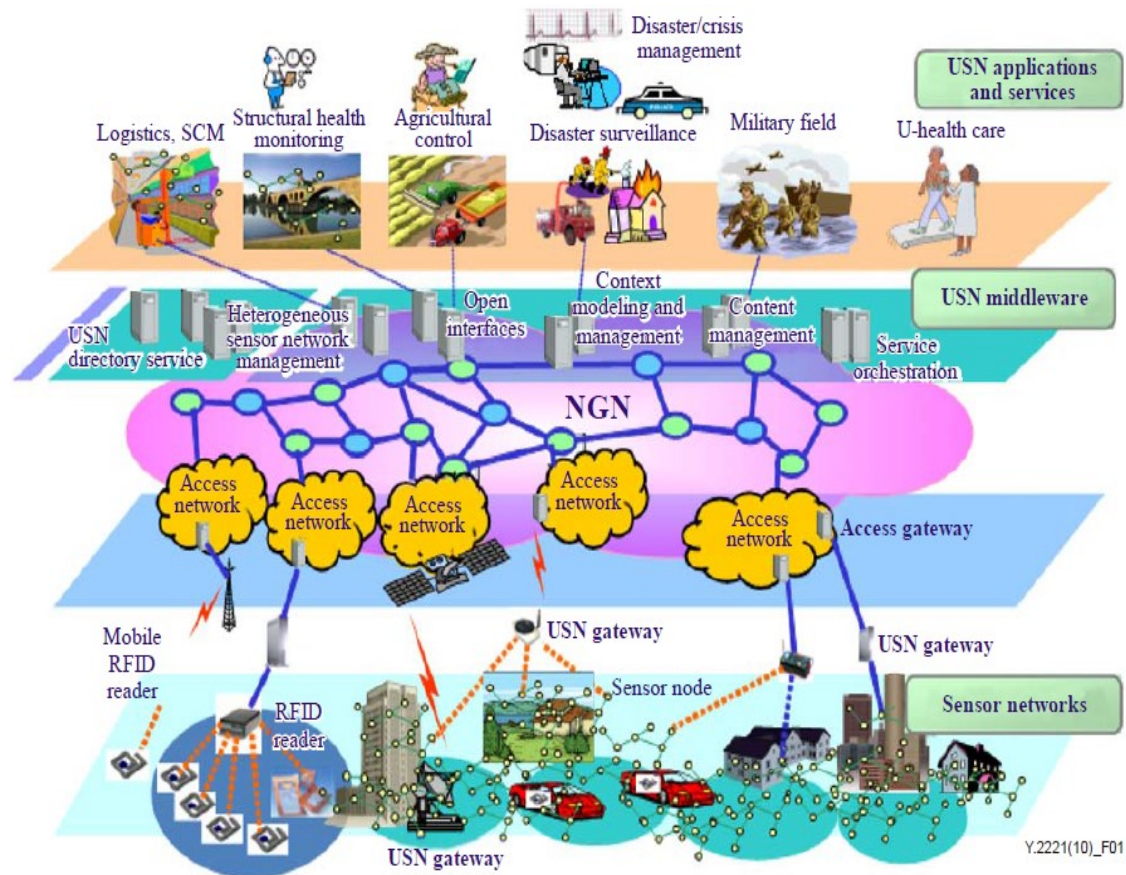
- **Sensor network:** Comprising sensors and an independent power source (e.g., battery, solar power). The sensors can then be used for collecting and transmitting information about their surrounding environment.
- **USN access network:** Intermediary or “sink nodes” collecting information from a group of sensors and facilitating communication with a control center or with external entities.
- **Network infrastructure:** likely to be based on the NGN.
- **USN middleware:** Software for the collection and processing of large volumes of data.
- **USN applications platform:** A technology platform to enable the effective use of a USN in a particular industrial sector or application.

Usually, SNs, which are compatible with IEEE 802.15.4 and run on the 868/916MHz or 2.4GHz Industrial, Scientific and Medical (ISM) frequency bands cannot communicate directly with public communication networks, which operate on Ethernet, IEEE 802.11, or GSM/GPRS networks. Consequently, a gateway is needed to work as protocols translator, impedance matching device, and rate converter between them.

As for the network gateways, there are multi-functional gateways each providing a specific task. These gateways could be divided into a scalable hierarchy. The first hierarchical level mandates a gateway capable of making a traverse translation between the IEEE 802.15.4 or any other protocol to IP. This gateway could be named a “Sink” or “USN gateway” and is dedicated to specific user(s) in a small area like homes, elderly houses, hospitals, etc. The higher level gateway is related to maintaining a data link to the operator network, which is called “Access gateway”. These gateway types are declared in Fig. 3.1.

Additionally, the communications between the nodes of a WSN that have to be governed by a set of rules (protocols) in order for them to function properly. Due to the difference of WSNs from other contemporary communication and wireless ad-hoc networks, routing is a very challenging task in WSNs. For the deployed sheer number of sensor nodes it is impractical to build a global scheme for them. IP-based protocols

cannot be applied to these networks. All applications of SNs have the requirement of sending the sensed data from multiple points. Therefore, a new efficient data aggregation protocol is proposed as will be discussed in the following sections.



**Figure 3.1:** Schematic layers of USN [1]

### 3.2 Challenges of Data Routing in WSN

Data routing is one of WSN research approaches. Routing in SNs is very challenging due to several characteristics that distinguish them from contemporary communication and wireless ad-hoc networks.

First of all, it is not possible to build global addressing and routing algorithms exactly as for classical IP-based protocols for the deployment of sheer numbers of energy and processing capacity constrained sensor nodes. Second, in contrary to typical communication networks, almost all applications of SNs require the flow of sensed data from multiple regions (sources) to a particular sink. Third, generated data traffic has significant redundancy in it. This is because multiple sensors may generate the same data within the vicinity of a phenomenon. Such redundancy needs to be exploited by

the data and goal-oriented routing protocols to improve energy and BW utilization. Fourth, sensor nodes are tightly constrained in terms of transmission power, on-board energy, processing capacity, and storage. Therefore, they require careful resource management.

Due to such differences, many new algorithms have been proposed for the problem of routing data in SNs. These routing mechanisms have considered the characteristics of sensor nodes along with the application and architecture requirements.

Data aggregation is the state of the art in data routing and the key technique to minimize energy consumption in large-scale information networks. Applying it in radio communication maximizes the network utilization by merging / compressing data coming from different sources into a single frame [37]. There are two approaches to implement the aggregation process. In the first approach, each node within a specific zone, such as a cluster, sends its data packet to a centralized point (aggregator) to be combined and mixed. This approach is called grid based. The second approach combines different nodes data packets while propagating the outcomes of the information sources to the sink(s). It is called in-network aggregation [38].

Data aggregation schemes are generally static, and derived from tree, cluster, or chain based architectures [39]. Cluster and tree aggregation approaches depend on the centralized point, while the chain depends on the in-network aggregation. Most of the contributions in this field focus on data gathering rather than the potential dynamicity of the gathering process.

Data mining in wireless networks is very interesting and vital for building new applications therefore, I rely on WSNs. They are interconnected and spatially distributed with the help of autonomous devices using sensors nodes to cooperatively monitor physical or environmental conditions (e.g. temperature, sound, vibration, pressure, motion or pollutants) at different locations [1].

WSNs have many limited resources such as limited BW, small memory size, and particularly battery power (or energy). Therefore, it is crucial to design a WSN that saves energy, and consequently prolongs the network lifetime [40]. Therefore, the thesis objective is to design a scalable WSN data mining architecture. This architecture has to be able to respond efficiently to queries such as monitoring, control, and data collection actions.

In this thesis, a new data aggregation protocol is proposed and is called Dynamic Aggregation Protocol (DAP). It uses a cooperative wireless network concept and yields to the following advantages:

- Reduction of the communication overhead needed to build a routing table for each network node and its periodic update as well.
- Making the aggregation path dynamic for each data gathering.
- Prevention of idle and low energy nodes from being involved in the transmission to save their energy for their own activities.

This protocol is designed to collect neighbors' data at each stop (along the nodes path to the sink). Aggregated sensors data is supposed to be different. Additionally, in-network aggregation is used as a promising technique to distribute the processing energy over all the network nodes on specific conditions. However, the study in this work is restricted to the networking part, which serves as a bearer to the information system architecture.

The following section presents the latest related work in this field followed by a detailed description of the new proposal.

### 3.3 Related Works

The aim of data aggregation protocols is to reduce the energy consumption by gathering, as possible, the sensors' collected data. Data packets are then manipulated at each aggregator along the aggregation path in order to reduce, merge, and remove redundant information to get a small packet size suitable for transmission efficiently to the sink. Since data transmission is responsible for the most of energy consumption, combining the transmitted packets at each network aggregator yields to the reduction of the transmitted packet size, which saves the network energy.

Data aggregation can be classified into two categories to improve the aggregation ratio<sup>1</sup> [39]. One category focuses on timing control. The other category focuses on establishing a proper routing scheme to improve the aggregation ratio. The most common approaches for aggregation protocols are cluster, chain, and tree based.

---

<sup>1</sup> Aggregation ratio is defined as the ratio of the number of packets generated by the applications to that received by the sink.

The cluster based approach organizes the sensor nodes into zones (clusters). Each zone has a cluster head responsible of receiving the sensed data from the cluster members (sensors) and sending it to the sink directly or through the other clusters heads in the network. Examples of this approach are Low-Energy Adaptive Clustering Hierarchy (LEACH) [41], Hybrid Energy-Efficient Distributed clustering (HEED) [42], and Two-hops clustering algorithm with a composed metric for WSNs [43].

The chain based approach organizes the sensors nodes into a chain taking the shortest path along which packets are sent to the sink. The chain can be constructed by employing a greedy algorithm or the sink can determine the chain in a centralized manner [40]. An example of the chain-based data aggregation protocol is Power-Efficient Gathering in Sensor Information Systems (PEGASIS) [44], which employs the greedy algorithm to construct the chain.

The tree based approach organizes the sensor nodes into a tree, where the aggregation is performed at intermediate nodes along the tree and a concise representation of the data is transmitted to the root node, which is usually the sink. The sources are located at the leaves of the tree and the parent nodes are responsible of the data aggregation. Examples of this approach are TRee based Energy Efficient Protocol for Sensor Information (TREEPSI) [45] and Energy-Aware Distributed heuristic (EADAT) [46].

The common disadvantages of these protocols are that the network passes by multiphase until settling and that most of the nodes energy is wasted in electing the zones headers and building routing tables. Also, these headers run out of energy quickly, and so the network lifetime is much less than expected.

Performance evaluation for the proposed protocol is compared with two other protocols, namely: i) data aggregation using Learning Automata protocol [47] and ii) the conventional routing protocol. Learning Automata protocol relies on gathering similar sensors data only. It consists of two phases: route discovery and route selection. The route discovery phase is used to build the routing table of each network's node using a broadcast packet pass through all the nodes. It is expected that a periodic update for these tables is required. The route selection phase is used to select a route among the available routes to maximize the aggregation ratio in the network. These available routes consider the shortest discovered paths to the sink and have the same length. In case a node has no similar neighboring sensors to the sink, it chooses a neighboring

node with more residual energy to forward its packets as a repeater and not as an aggregator.

One of the aggregation protocols challenges in WSNs is the data compression. The data aggregation protocols in WSN are assumed to collect the information of the similar sensor nodes, which adds more complexity and limitations to these protocols. A few literatures discuss the compression of multiple data types in WSN. One of these recent techniques uses adaptive arithmetic coding with low updating cost that could achieve approximately 54% data compression [47]. This achievement opens the way for developing new efficient data aggregation protocols independent on the similarity of the sensors information type. In my proposal, I will exploit this result and consider the compression on the data collected of different types.

### **3.4 DAP: Dynamic Aggregation Protocol**

#### **3.4.1 Algorithm Description**

DAP is a hybrid data aggregation protocol, which is considered a compromise of the chain and cluster approaches. It is considered a dynamic protocol as the aggregation path is dynamically selected according to the contention process described in the following.

Consider a node having a sensed data and needs to send it to the sink. Based on DAP, the node will pass by the following steps to deliver its data to the sink, which is illustrated in the flow chart of Fig. 3.2.

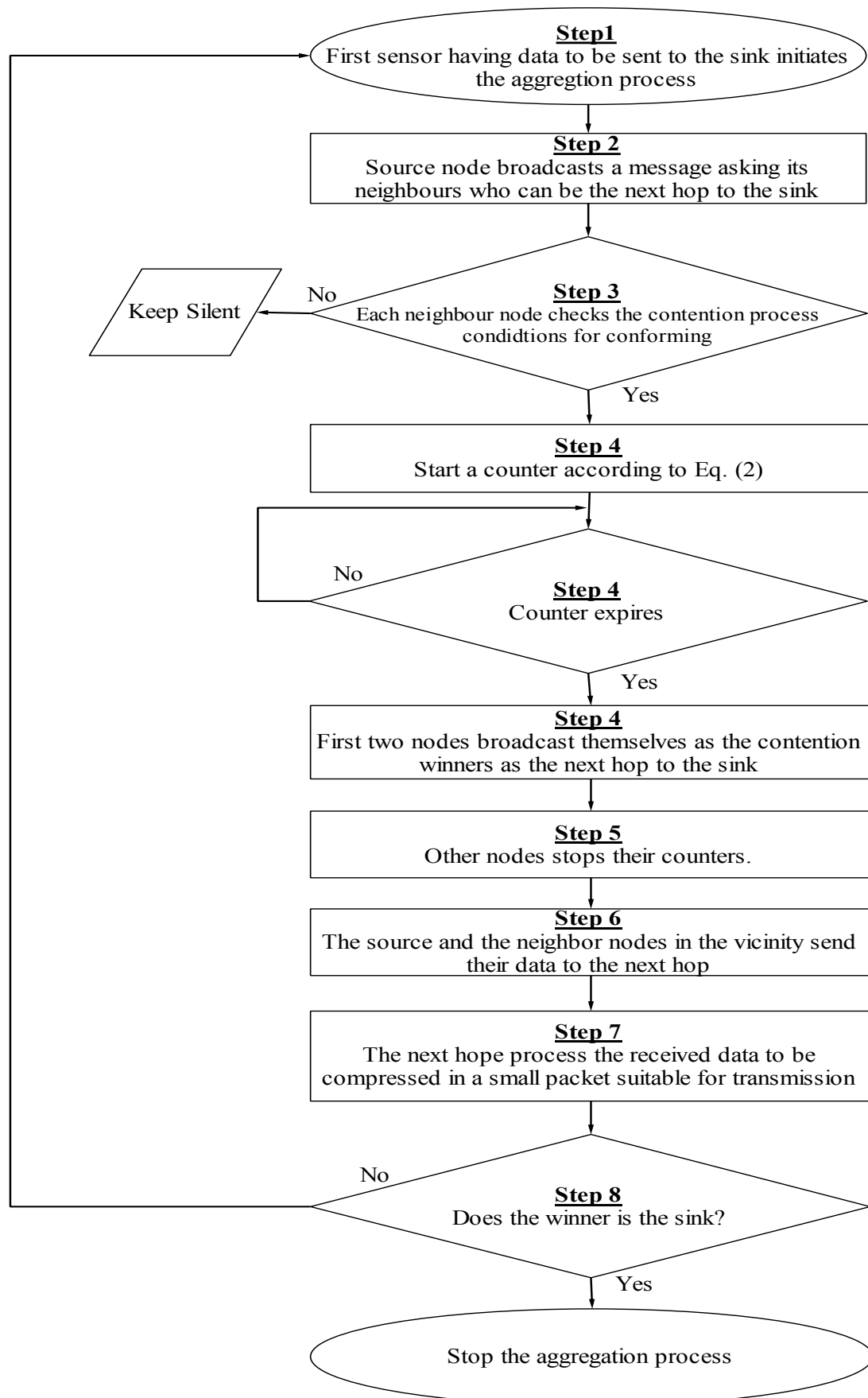


Figure 3.2: DAP Flow Chart

**Step 1:** the initiator of the aggregation process is the first sensor having a data message to be sent to the sink.

**Step 2:** this initiator node broadcasts a message asking all the surrounding nodes: “who can be my next hop to the sink?”.

**Step 3:** the surrounding nodes receive this message and hence start a contention process to elect one of them (contention winner) to handle the transmission of the source node data.

According to the algorithm rules and for optimizing the performance of the protocol, every node receiving this contention announcement must conform to the following four conditions to participate in the contention process:

- a) It must have its own data message, which needs to be sent also to the sink. This condition is to conserve the energy of the idle nodes to its activity only. Meanwhile, there is no condition for the type of data to be relayed. It could be of different sensed information type. Therefore, the data aggregation process does not depend on the sensors' type.
- b) It must have enough residual energy for the processing and transmission functions. These constraints are very essential condition to make sure the intended node is capable of finishing this task successfully.
- c) The distance from the sink to the node that is willing to participate in the contention process must be less than that to the source node, which can be determined as in [49]. This condition will grant the benefit of making the aggregation path as short as possible and prevents the transmissions loops. For applying that condition, each candidate can decide whether to get into the contention process or not by calculating the Euclidean distance using Eq. (3.1):

$$P(S_n, D_n, F_n) = \text{dist}(F_n, D_n) - \text{dist}(S_n, D_n) \quad (3.1)$$

where  $S_n$ ,  $D_n$ , and  $F_n$  represent the source, the destination, and the next forwarding node locations respectively. If the value of Eq. (3.1) is negative, this means that the forwarding node is closer to the sink than the source and therefore it could get into the contention. Otherwise, this node is farther from the sink than the source and will not get into the contention process.



- d) This node must check its Link Quality Indication / Energy Dedication ( $LQI / ED$ ) to make sure it receives the source node signal with a good SNR, which alleviates the need for retransmissions and saves the power of the sensor nodes to prolong their lifetime.

If the above conditions are fulfilled, the node can be processed to step (4).

**Step 4:** each conformed node starts a counter according to the timer of Eq. (3.2), and the first two nodes whose counters expire send a broadcast message informing the source node and the other neighbors in the vicinity.

$$T_R = \left( \frac{T_{\max}}{LE + En} \right) - rand \left( \frac{T_{\max} / 2}{LE + En} \right) \quad (3.2)$$

where  $LE$  and  $En$  are the  $LQI / ED$  and the residual energy.  $LE$  and  $En$  are normalized  $\in (0,1)$ .  $T_{\max}$  represents the maximum delay time that the source node has to wait for a next hop node to answer. The  $rand(x)$  function generates a random value between 0 and  $x$ . This function is added to avoid having more than one winner with equal values and alleviates the contention process collisions that could happen between nodes with the same parameters.

Then, the first contention winner will be considered as the next forwarding node (the next hop), and the second winner will act as a relay for the source in case its data message is received corrupted at the forwarding node or lost. Thus, there are two relay nodes now, the first winner is the primary relay, and the second winner is the backup for data recovery of that primary relay.

**Step 5:** when the nodes in the vicinity receive these two winner messages, they stop their counters. If there are nodes participating in the contention process and outside the communication range of the winners, they will not receive their broadcast messages according to that. However, these nodes will eventually detect this election result when the source node starts sending its data message to the contention winner and hence stop their timers. The mechanism of the second winner (secondary relay) is explained later in the next section.

**Step 6:** the neighbor nodes are aware now of the winner. It will be considered as the data aggregator for this vicinity. These nodes will start sending their data to that winner as a next hop to the sink.

**Step 7:** the winner starts processing the received messages. Using statistics, the next hop node combines, compresses, and removes redundancy etc. to fit the received messages into one small packet suitable for transmission. This is done independently from the type of the messages' data as mentioned before.

**Step 8:** the winner node becomes now the new data source and needs to pass its message to the sink. It repeats the algorithm process starting from step 2 until the data message is delivered to the next hop. The whole process will be repeated until the packet reaches the sink.

As shown, the DAP technique behaves like a train moving from one station to another (source to next hop). As the train moves, it advertises its location at each station stop (aggregation nodes) to the vicinity nodes. According to that, every node having a data message can forward it to this temporary train stop until reaching the last station stop, which is the (sink).

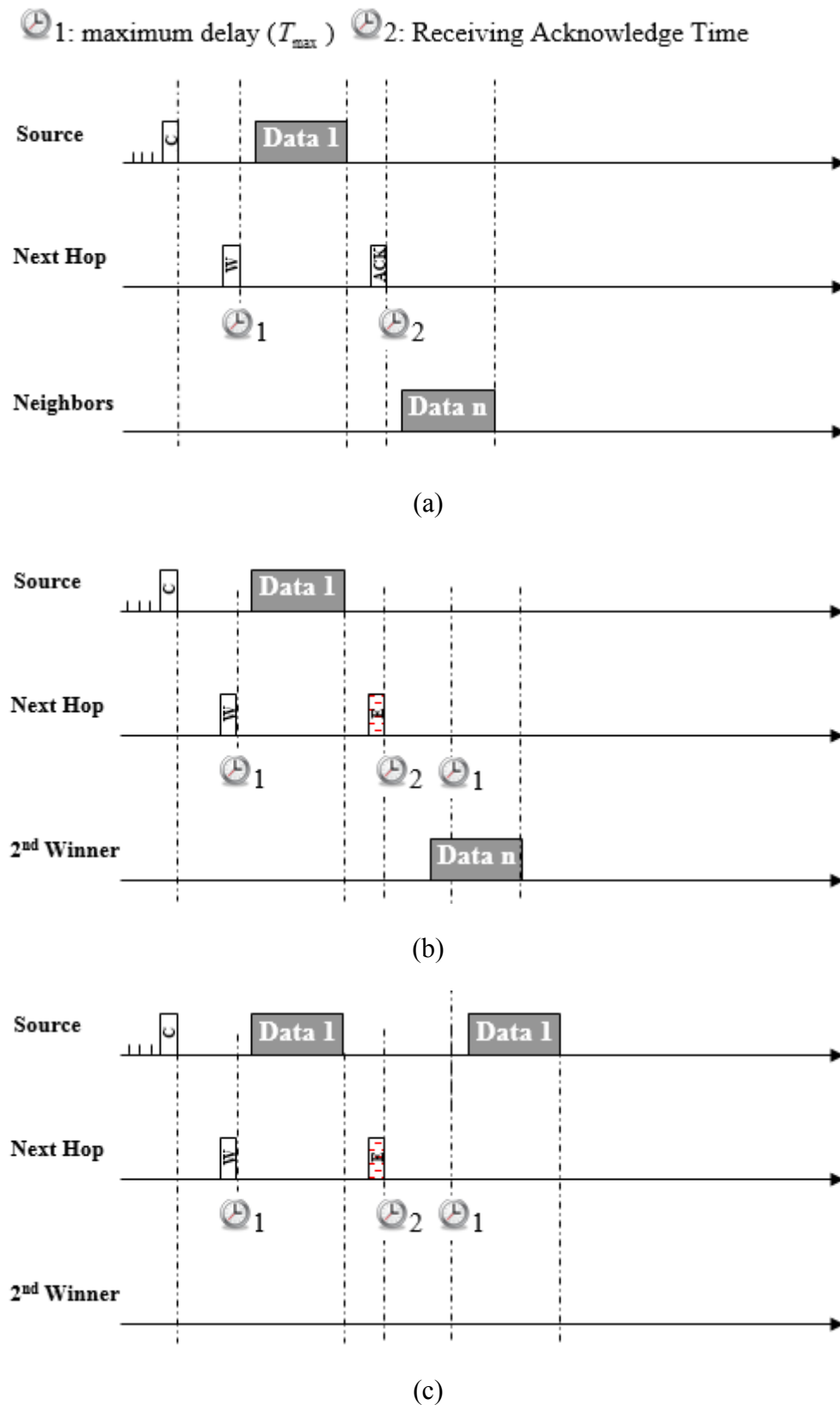
DAP algorithm can be practically easily fulfilled for the following reasons:

- As the SNs consist of thousands or at least hundreds of nodes, there are for sure neighbors for each source node. It is also expected that a number of them will have enough energy for the data processing and transmission.
- Keeping the idle nodes silent (according to their triggering time) conserves their energy, which saves its data transmissions status from failing and hence prolongs the network lifetime.
- Determining the nodes position with respect to the sink prevents initiating loops and improves selecting the shortest path to the sink. Many approaches as in [50] propose algorithms to identify the nodes location relative to the sink.
- Ensuring a good communication link between the source and its neighbors participating in the contention prevents retransmissions and saves the nodes energies.

### 3.4.2 Data Recovery

Since wireless sensor nodes suffer from low power and have a high possibility of communication failure, the transmitted data message maybe received corrupted or lost by the next hop (the primary contention winner). To guarantee the reliability of data transmission, a new technique is proposed to alleviate this situation effect and decrease the need for retransmissions, which improves the network lifetime. The recovery process is explained in the following paragraph and as shown in Fig. 3.2.

After sending its data message, the source node waits for an acknowledgment for a timer-2 period. If the next hop receives the data message without errors, it sends an acknowledge message (ACK) within the timer-2 period and starts processing the received data message as shown in Fig. 3.3 (a). On the other hand, if the next hope receives the data message corrupted or the data is lost, it replies with a broadcast error message (E) as shown in Fig. 3.3 (b). Consequently, the source node waits for a timer-1 period before trying to retransmit the data message. This is because the relay node (the second winner) may have already received the source node's data message correctly. In this case, as the relay node follows the same conditions of step 3 within timer-1 period as in Fig. 3.3 (b), it will resolve this problem. Moreover, the relay node will not transmit the source data message only. Instead, it will transmit an aggregated packet containing the two messages of the source node's data and its own data. In the case of there is no reply within the timer-1 period, the source node will know that there is no relay node that can serve instead of it and will retransmit its data message after the timer-1 expiry as in Fig. 3.3 (c). Since wireless sensor nodes suffer from low power and have a high possibility of communication failure, the transmitted data message maybe received corrupted or lost by the next hop (the primary contention winner). To guarantee the reliability of data transmission, a new technique is proposed to alleviate this situation effect and decrease the need for retransmissions, which improves the network lifetime. The recovery process is explained in the following paragraph and as shown in Fig. 3.2.



**Figure 3.3:** Data recovery. (a) Source node data received correctly, (b) 2<sup>nd</sup> winner relays source node data, (c) Source node send its corrupted data again

### 3.5 Performance Evaluation

This section is divided into two parts. The first part is for the simulation network model and contains the network specification and the different protocols used to compare with. The second part evaluates the performance of the proposed protocol “DAP” and discusses the simulation results. Matlab (R2011a) is used for simulating DAP performance.

#### 3.5.1 Simulation Network Model

The proposed network model consists of randomly distributed sensors on a rectangular field  $G(V,E)$ , where  $V = \{v_1, v_2, \dots, v_n\}$  is a finite set of nodes and  $E = \{e_1, e_2, \dots, e_n\}$  is a finite set of links. Each network’s node is aware of its location and capable of sensing, transmitting, receiving, and aggregating data messages.

A network model of 100 up to 500 nodes in a step of 100 was created on a square area plan of 200m x 200m as shown in Fig. 3.4. The network contains one sink. The use of only one sink does not restrict the system. This is because even if there is more than one sink within the network, the proposed protocol already rely on using the shortest path to the closer sink available. The network nodes are randomly distributed in the area plan and have a limited communication range according to the sensors specifications. It is expected that not all the network nodes are neighbors to each other (no direct link between every two nodes) as the communication range is the dominant.

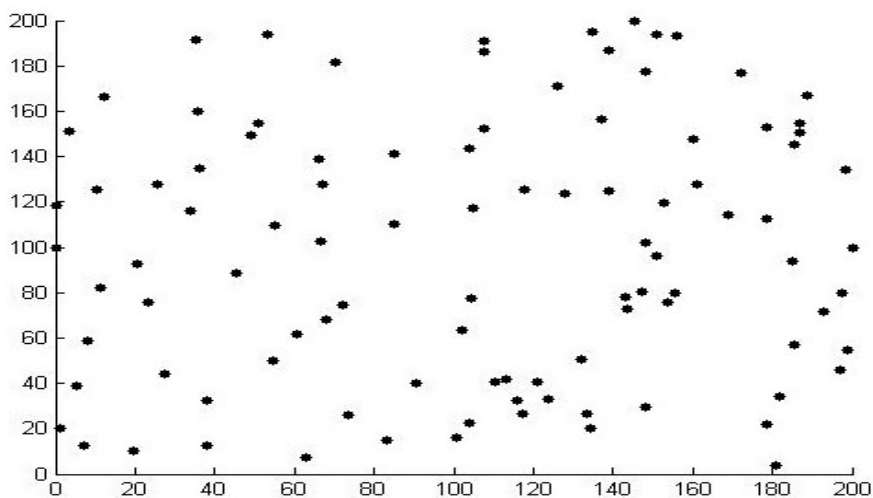
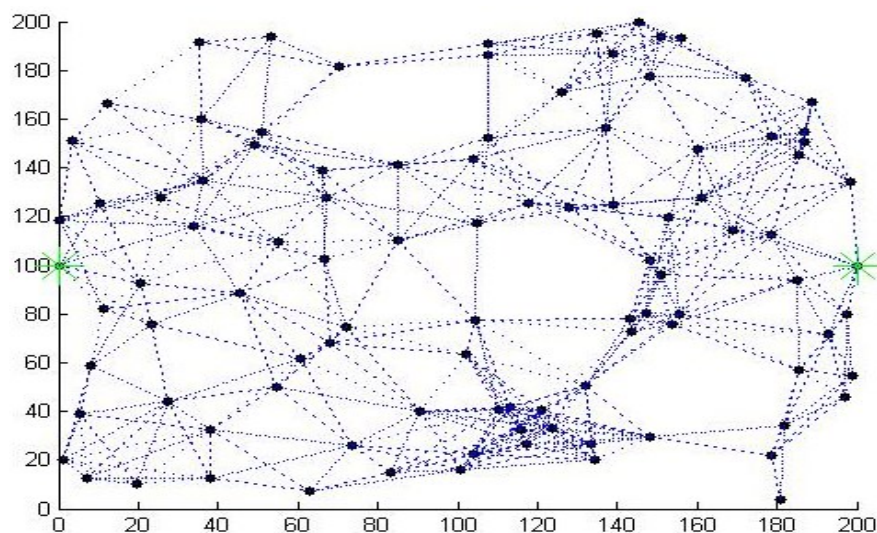


Figure 3.4: Network model with 100 sensor nodes

In the simulation scenarios, different sensors types are used. Each sensor is responsible of a specific parameter such as (pressure, temperature, humidity, etc.). In addition, each set of these data types has a trigger plan to send its data message according to the applications needs.

The used nodes have limited energy and transmission range according to the specifications of the sensors nodes. Therefore, the neighbors of each node are different depending on its location within the network. These nodes transmit their sensed information periodically to the sink. Figure 3.5 shows the links between neighbor network nodes as dashed lines.



**Figure 3.5:** Link connections between neighbors

Next part reviews the performance results and compare between the three relevant protocols: the proposed protocol DAP, the data aggregation protocol “data aggregation based on Learning Automata” [47], and the conventional routing protocol using the shortest path between a source and the network’s sink.

Real values are used in the following simulation experiments for the sensor’s bit rate, transmission range, and power calculations according to typical operating conditions of the sensors in [51] as shown in Table 3.1.

According to the precautions of [51], the operating voltage for this type of sensors (tmote sky) is not less than 3V when attached to USB, and 2.7V when is programmed. Therefore, the maximum supply voltage of 3.6V is used in the following simulation experiments. Moreover, the antenna communication range may attain 50m

for indoors and up to 125m range for outdoors. However, in these simulations, the communication range of 30m is used for more strict evaluation conditions.

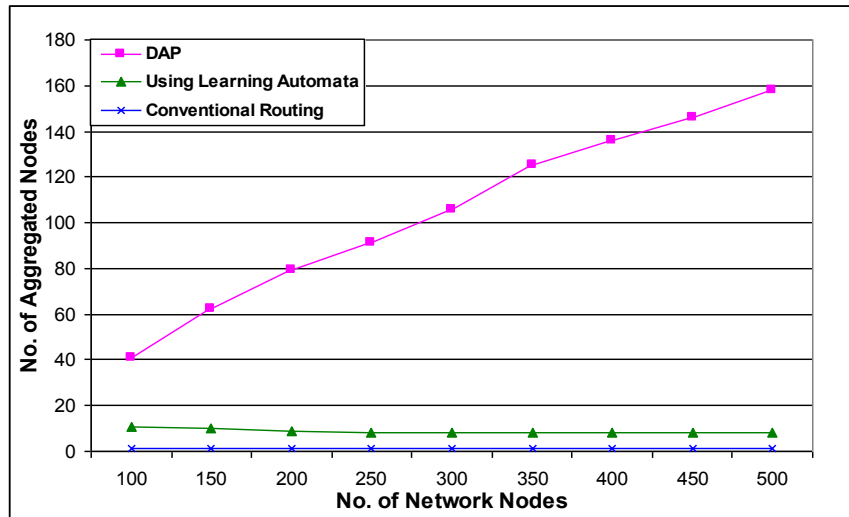
**Table 3.1:** Typical Sensors' Radio Operating Conditions

	<b>Min</b>	<b>Nom</b>	<b>Max</b>	<b>Unit</b>
<b>Supply Voltage</b>	2.1		3.6	V
<b>Active current at Vcc = 3V, 1MHz</b>		500	600	mA
<b>RF frequency range</b>	2400		2483.5	MHz
<b>Integrated onboard antenna (Coverage Range)</b>	50 (Indoor)		125 (Outdoor)	Meter
<b>Current consumption: Radio transmitting (TX) at 0 dBm</b>		17.4		mA
<b>Current consumption: Radio receiving (RX)</b>		19.7		mA
<b>Current consumption: Idle mode, Oscillator off</b>		20		$\mu$ A
<b>Transmit bit rate</b>	250		250	kbps

### 3.5.2 Simulation Results and Analysis

**Experiment 1:** in this scenario, the effect of the number of network nodes on the aggregation ratio performance was studied for the three protocols mentioned in the simulation network model subsection. The sensor nodes are considered of different data types. The simulation is repeated several times with the increase of the number of the network nodes from 100 to 500 insteps of 100. Figure 3.6 shows the number of aggregated nodes for the three protocols in terms of the total network nodes. The Figure shows that the number of aggregated nodes for DAP is more than for the other two protocols. It is also clear from the Figure that the aggregation ratio increases with the number of network nodes in case of DAP, while it remains almost constant for the Learning Automata based and the default routing protocols. This means that the DAP utilization is directly proportional to the number of network nodes and that it is more efficient when the network is more dense. On the contrary, the other two protocols achieve almost the same behavior with the increase of the number of network nodes.

This is due to that Learning Automata based protocol focuses on discovering the shortest path. Hence, the average path size will not change due to the fixed network dimensions. As for the conventional routing, it achieves the lowest behavior due to the nodes messages delivery and does not consider the data aggregation.

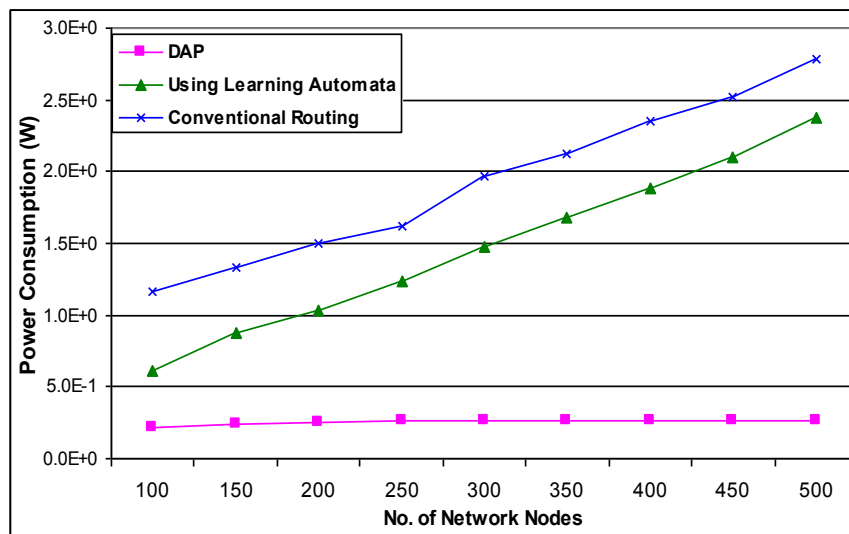


**Figure 3.6:** The aggregation ratio for the three algorithms

**Experiment 2:** in this experiment, the power consumption per node is calculated for each algorithm. The sensor nodes are considered of different data types. The simulation is repeated several times with the increase of the number of the network nodes from 100 up to 500 insteps of 100. Figure 3.7 shows the power consumption per node in watt for each protocol with respect to the number of the network nodes. Because there is a neighbor discovery phase for building routing tables in both the Conventional Routing and Learning Automata protocols, the power consumption per node is directly proportional to the number of network nodes. On the other hand, DAP discovers its routes while transmitting and does not build any routing tables. Therefore, it is more efficient in power budget with respect to the number of aggregated nodes as shown in the Figure. From the same Figure, the power consumption per node using DAP is almost constant with the increase of the number of network nodes. The power consumption of the contention process is taken into consideration, and as proved by the Figure, it has a neglected effect, while there is an impact on the nodes' energy due to building routing tables for the other two protocols. As the SN becomes dense in terms of the sensor nodes, DAP is the best protocol that can be exploited, while the other protocols cost of

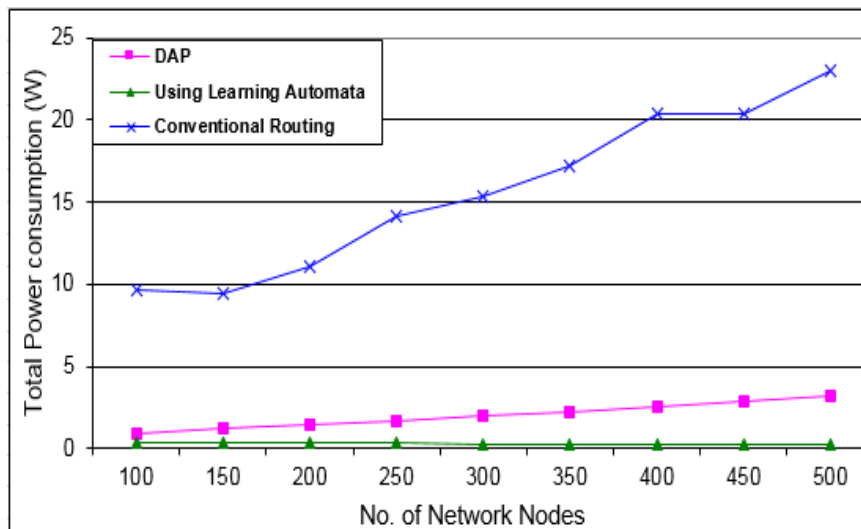


energy is high and constitute a barrier from being implemented when the number of nodes reaches thousands.

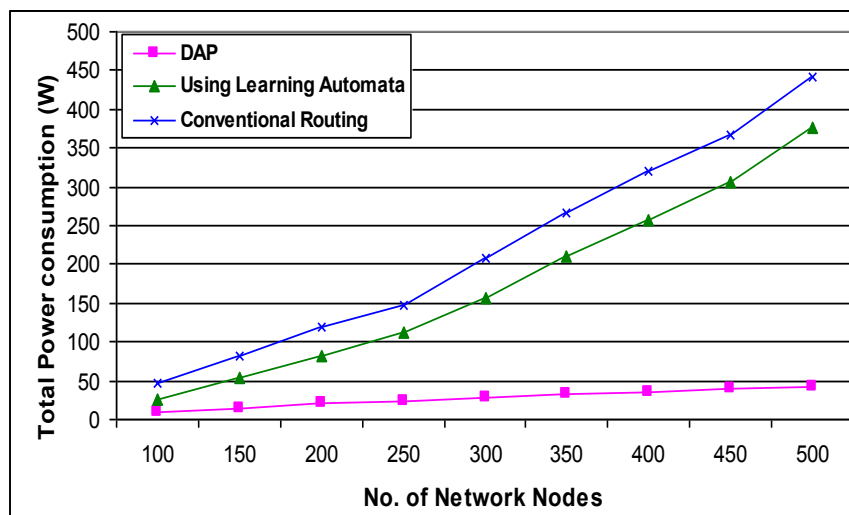


**Figure 3.7:** Power consumption per node

**Experiment 3:** in this scenario, the total power consumption of each protocol was calculated to determine the protocol that will provide more power saving with respect to the number of network nodes. The sensor nodes are considered of different data types. The simulation is repeated with the increase of the number of the network nodes from 100 up to 500 insteps of 100. Figure 3.8 shows the power consumption in watt of each protocol with respect to the number of the network nodes. The Figure shows that Learning Automata protocol achieves the lowest power consumption. However, to complete the comparison between the three protocols, it is needed to relate the power consumption of each protocol to the number of aggregated data messages. As proved in experiment 1, DAP collects data from a number of nodes more than the Learning Automata protocol due to the higher aggregation it achieves. Considering this, the total power consumption is recalculated according to the number of aggregated nodes as shown in Fig. 3.9. In the Figure, DAP achieves the best efficient power consumption among the three protocols with respect to the same number of aggregated data messages (158 messages). As shown in the figure, the total power consumption of DAP increases by a small rate. This is expected as the number of neighbor nodes increases in dense network. Hence, the number of aggregated nodes data increases. Observe that the total power consumption of the other two protocols increases by a great step in dense network due to high power wasted in large routing table size.



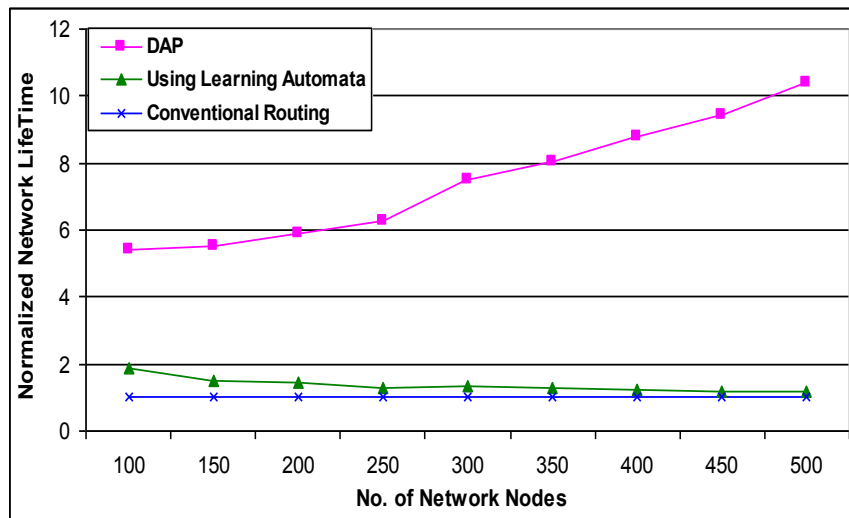
**Figure 3.8:** Total power consumption for each algorithm



**Figure 3.9:** Total power consumption for each algorithm with respect to the same number of aggregated data messages

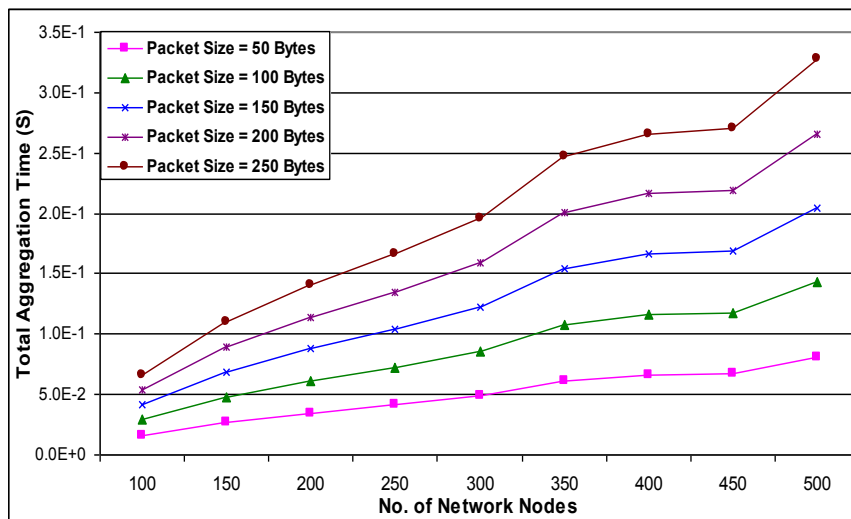
**Experiment 4:** the objective of this scenario is to compare between the three protocols with respect to the network lifetime. The lifetime of the conventional routing is considered as the default (the normalized lifetime). The results are obtained by calculating the power consumed by each protocol with respect to number of aggregated nodes. The sensor nodes are considered of different types. This scenario is repeated several times with the increase of the number of network nodes from 100 to 500 in steps of 100. Figure 3.10 shows that the normalized network lifetime of DAP is higher than

the two other protocols. On the other hand, DAP achieves better lifetime especially in high dense networks, which is consistent with the size specification of the SNs.



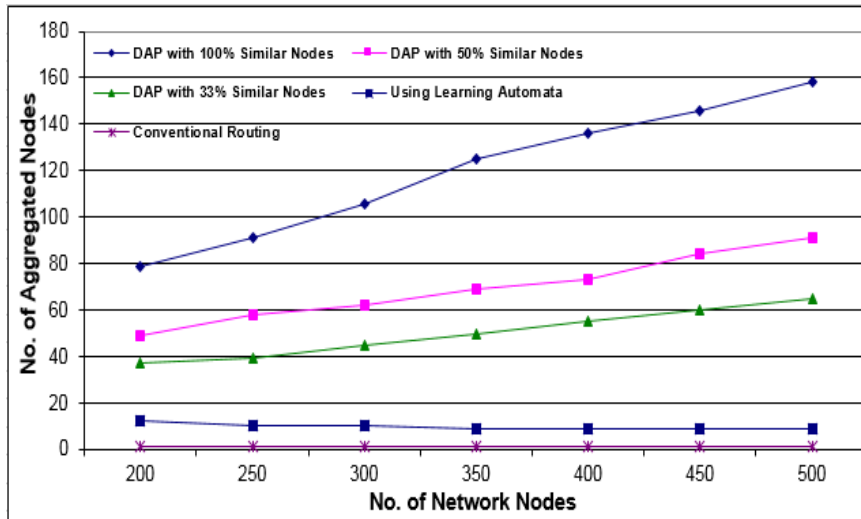
**Figure 3.10:** Network lifetime

**Experiment 5:** since applications could be sensitive to time delay, the aggregation time is a vital factor to be studied with respect to the packet size. Moreover, the packet size is important as large packets can save energy and BW. Therefore, this scenario calculated the aggregation time (in seconds) for DAP with respect to the sensors packet size. The sensors nodes are considered of different types. The simulation is repeated several times with the increase of the number of the network nodes from 100 to 500 insteps of 100. The tested packet sizes are 50, 100, 150, 200, and 250 Bytes. The other protocols are not included in this study as the previous experiments proved that DAP achieved the best behavior in comparison to them. Figure 3.10 shows the total aggregation time in seconds that is needed for the different packet sizes corresponding to the number of network nodes. The Figure shows that, as the packet size increases, more time is required to collect and aggregate the packets from the neighbor nodes before transmitting them. MAC layer delays and carrier sense mechanism were taken into consideration in the simulation program for calculating the time needed for data gathering. The channel listening time before transmitting used is  $128\mu\text{s}$ .



**Figure 3.11:** Aggregation time with respect to the packet size

**Experiment 6:** the objective of this scenario is to compare between the number of aggregated nodes for the three protocols corresponding to percentages of sensor data similarities (100%, 50%, and 33%) as the Learning Automata is based on aggregating the nodes packets of similar data. Moreover, for the data aggregation protocol based on Learning Automata, the longest aggregation path for the three supposed percentages was used to increase the protocol aggregation ratio. The simulation is repeated several times with the increase of the number of network nodes from 100 to 500 in steps of 100. Figure 3.12 shows the number of aggregated nodes with respect to the number of the network nodes. As shown in the Figure, DAP achieves superior performance compared to the other protocols even when the aggregation process occurs between the 33% of network nodes.



**Figure 3.12:** Comparison between the aggregation capabilities of the three algorithms in case of different similar nodes percentage

In [47], the performance results of the data aggregation protocol based on Learning Automata were compared with three other protocols: i) LEACH [41], ii) location aware routing with no learning [52], and iii) routing based on Q-learning approach [53]. It was proved that Learning Automata is better. Consequently, DAP is considered as a better protocol compared to these three protocols as well.

### Comparing DAP with Data Aggregation Based on Learning Automata

- DAP sets up each node along the aggregation path (shortest path) as a temporary station stop for collecting sensors data messages from neighbor nodes. This increases the aggregation ratio. On the contrary, the data aggregation based on Learning Automata collects data messages of the path's nodes only.
- DAP provides aggregation of different sensors data types that maximizes the aggregation ratio, while the data aggregation based on Learning Automata focuses on the similar nodes data messages only. This causes every nodes set of similar data type to have different path to aggregate the sensed information, which doubles the cost of the aggregation theoretically.
- DAP establishes the shortest path to the sink in parallel with the aggregation process i.e. it performs these two functions (path discovery, and aggregation process) in one step. On the other hand, the data aggregation protocol based on Learning Automata performs both functions in two phases.

### 3.6 Conclusion

In this chapter, a new data aggregation protocol is proposed to achieve energy-efficient utilization for WSNs. The main energy consumption factor is the transmission power. Data aggregation presents the optimum solution to decrease it by collecting sensors' data into one packet suitable for being transmitted to the sink. The problem is how to collect sensors' data packets from the vicinity. There are many approaches to this point depending on the network topology (cluster, tree, and chain). DAP is considered a compromise of all these methods.

From the simulation results, DAP achieves superior performance compared to the conventional routing and data aggregation using Learning Automata protocols. From the simulation Figures, DAP achieves better energy consumption, and consequently extends network lifetime. Even assuming data similarity of 50% and 33% among nodes, DAP achieves aggregation with better performance than the other protocols. The simulation results prove also that the aggregation ratio increases as the number of nodes and their density in the network increase compared to other solutions that are not affected with these parameters.

This developed protocol is dedicated to guarantee that the number of messages delivered by the WSN to any application core network are reduced by a great factor. Consequently, it solves the load on the core network resulting from the myriad number of messages expected from the WSN.

Chapter three paved the path for building an intelligent information infrastructure of WSN that could be connected to any proposed network platform for building new applications.

In the next chapter, a complete model for the integration between the USN and the IMS-based NGN is presented. This integration establishes the platform that enables enhanced and flexible service creation and provisioning for building new applications based on the requirements of the ITU recommendations [1]. The detailed network architecture proposed is investigated. In addition, the aim of using the IMS as a controller sub-layer for that application is mentioned including the benefits and the features of the IMS.

## Chapter 4

### New e-Health Signaling Model in the USN Environment

#### Contents

---

<b>4.1 Introduction</b> .....	<b>50</b>
<b>4.2 Benefits of IMS</b> .....	<b>51</b>
<b>4.3 Related Work</b> .....	<b>53</b>
<b>4.4 Proposed Network and Service Architecture</b> .....	<b>54</b>
<b>4.5 Signaling Scenarios</b> .....	<b>57</b>
4.5.1 Initialization and Registration .....	58
4.5.2 First Scenario (Periodic Transmissions) .....	61
4.5.3 Second Scenario (Emergency Case) .....	62
4.5.4 Third Scenario .....	63
4.5.5 Fourth Scenario .....	65
<b>4.6 Potential Applications</b> .....	<b>66</b>
<b>4.7 Performance Evaluation</b> .....	<b>66</b>
<b>4.8 Conclusion</b> .....	<b>73</b>

---

#### 4.1 Introduction

In this chapter, an integration architecture between USN and IMS-based NGN is proposed. IMS is used as a controller sub-layer in the USN environment for fulfilling the ITU service requirements [1] of USN applications and services. Moreover, a full detailed architecture model for e-Health application is introduced.

The ITU recommendations [1] introduce the requirements for support of USN applications and services. USN applications and services are created via the integration of the SNs into the network infrastructure, which is proposed to be NGN. The integration between USN and NGN is proposed due to the wide range of the capabilities and properties of NGN that make it an ideal candidate to that integration. These capabilities required for the support of USN application and services are QoS,

connectivity, location management, mobility, identification, authentication and authorization, accounting and charging, privacy, and security.

On the other hand, the ITU proposed the integration between USN and NGN without specifying neither the details of that integration nor the used protocols. This is still an open subject. Therefore, in this thesis, a complete model including a detailed network architecture for that integration is introduced. This model proposes the integration between USN and IMS-based NGN. IMS is used to provide a controller sub-layer for implementing USN applications. The benefits of using the IMS is mentioned in the next section.

Moreover, one of the main emerging domains and use cases of USN applications is the e-Health. It has been invented to exploit the wide use of the USNs to gather the patients' medical and non-medical data for various applications. Sensors, physically placed on the human body, create a wireless body area network (BAN) that can monitor various vital signs (heartbeats, blood pressure, oxygen saturation, activity, etc.) while providing real-time feedback to the user and medical personnel. Further, wireless sensors can be deployed in a patient's home environment to provide real-time and extended monitoring of activity, wellbeing, and environmental parameters (location, temperature, humidity, light, etc.) [54]. There are trials for deploying e-Health applications. However, they are not complete solutions and will be described in the related work section. In this chapter, a complete solution is proposed using IMS-based NGN as a controller sub-layer for the e-Health application.

Next section reviews the benefits of using IMS in the integration with the USN and the facilities provided.

## 4.2 Benefits of IMS

Many detailed challenges are associated with the development of a framework of globally distributed WSNs.

- Heterogeneity
- Suitable abstraction levels and information models
- Scalability
- Adaptivity
- Processing support



To date, many architectures have been developed for addressing the above challenges. However, none of these solutions addresses these challenges in a satisfying way. In particular for integration in network infrastructures the above challenges is still an open question. I believe that IMS provides an excellent basis for defining an architecture that is able to cope with huge number of sensors context-based services and large number of users. In particular, the benefits of IMS-based architecture are as follows:

- All-IP based scalable message routing across administrative domains
- Supports mobile roaming users as well as fixed networks
- Re-usable core functionalities
- Trusted platform operator
- Extensive set of services
- Extended and flexible session control

IMS is an all-IP based platform that offers in its SIP-based core scalable message routing across several administrative domains. It can handle different access networks such as xDSL, satellite, GPRS, CDMA, GSM, HSDPA, or LTE. This is an important property in order to address the above mentioned heterogeneity of SNs. In particular, its separation between data, control and application layer provides a good basis for a scalable architecture and decouples the services from the network.

IMS also supports mobile roaming users as well as users in fixed networks. This addresses naturally the heterogeneity of various SNs with respect to their mobility. For instance, BANs are mobile networks of a dynamic nature, whereas SNs for environmental monitoring or structural monitoring of buildings are fixed and static. IMS's tight relation with mobile phones also provides a good infrastructural basis for accessing SNs via the mobile phone.

In addition, IMS provides a set of core functionalities that are required by any modern and serious platform. This includes for instance authorization, authentication, accounting, security and QoS functionalities that are able to cope with a large number of users. A sensor architecture does not need to define these functionalities on its own, but can directly re-use these functionalities and focus on the core functionalities to provide its main service, i.e. providing access to sensor and context information.

Another benefit that is related to the above mentioned core functionalities is the fact that IMS is typically operated by large operators that are already dealing with millions of sensitive customer data. Customers have built up a long historic trust relationship with these operators. This is important as sensor and context information may contain even more sensitive data that requires protection from misuse and unauthorized access. Here telecom operators could play a major role in providing privacy protecting services exploiting the capabilities of IMS. IMS also benefits from the fact that the Open Mobile Alliance (OMA) [55] is continuously defining service enablers such as presence or push services that are used. Adding a sensor and context enabler facilitates the development of end-user services, as it only needs to support one platform.

Finally, IMS provides extended and flexible session control. Sessions can be dynamically changed and updated. This provides an excellent basis for addressing the adaptive challenge described in the previous subsection and enables features such as load balancing, session continuity and ensuring quality requirements on the data that has been specified by an application.

### **4.3 Related Work**

Considerable ongoing research efforts are focusing on providing the physical design for the USN entities according to the ITU requirements. Some of these proposals based on Context Awareness (CA) such as [56] [57] [58]. Also, an integration between service enablers based on the CA system is proposed to provide various services in [59]. Another work proposed a context aware mobile service platform supporting mobile caregivers in their daily activities [60]. They have demonstrated its capability for providing an extensible set of services aiming at supporting care networks in cooperating and sharing information for the goal of improving a chronic patient's quality of life. This work was used for health monitoring and alarm management of chronic conditions in a home-based care scenario [61]. The CA service architecture proposed in [62] can also be used in order to integrate with social networks.

Another group of researches concentrated on providing a network and service integration techniques for the USN with the IMS. One of the recent solutions is based on building a service enabler over the IMS to support e-Health services without mentioning the consideration of the core network [63] [64].

Most of this research and standardization efforts proposed only theoretical ideas and potential scenarios. However, they did not provide a detailed signaling flow to be the roadmap for implementing these e-Services. Also, they didn't define a complete architecture for implementing e-Services, which make it implementable proposes.

In this thesis, the usage of IMS as a service controller sub-layer in the USN environment is proposed. The IMS platform is used to utilize its benefits and features [63] and to provide the service requirements of USN applications and services [1]. The main contributions of in this chapter are:

- A detailed network design for implementing the proposed service including new functional entities for the Service Layer. It is simple, flexible, and does not require great changes in the already established communication networks.
- A detailed network signaling flow for different applicable e-Health scenarios using SIP.
- Modification of the SIP protocol to match the features provided in the proposed e-Health service.
- Emergency cases detection, which is practically vital to save patients life.

Further emphasizes on the middleware sub-layer entities functions was provided for the proposed detailed network design for the integration between USN and the IMS-based NGN. In addition, an evaluation section of the proposed emergency scenarios is provided.

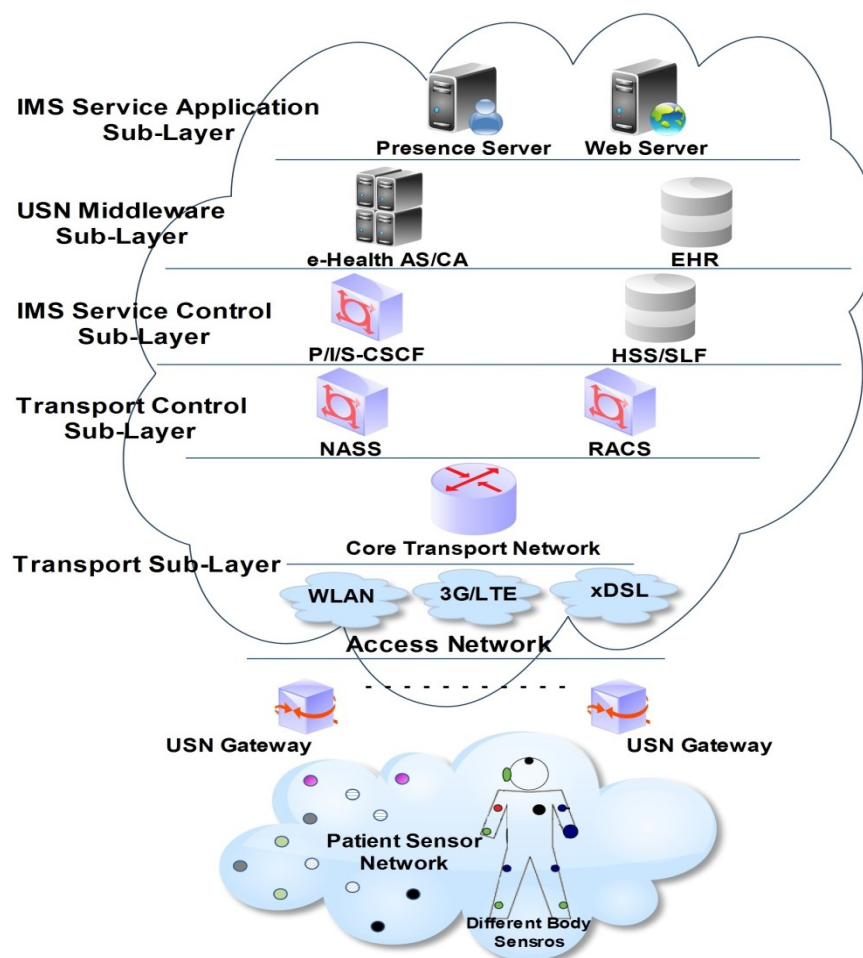
#### **4.4 Proposed Network and Service Architecture**

The proposed network follows the IMS-based NGN architecture according to the requirements for the USN applications and services [1]. These requirements are suggested in the form of physical devices as described in the proposed model as shown in Fig. 4.1. The architecture is divided into two stratum: transport stratum and service stratum.

The patient SN contains different types of sensor nodes with wireless capability. These nodes observe the patient and the surrounding atmosphere as well. A USN Gateway is used to translate between the network's access protocol and that of the sensor nodes providing the connectivity requirement to the IMS infrastructure. It can collect data from one patient, or many patients as in elders' homes. The Gateway is not

required if the sensor element has a built-in IP capability. Collected data maybe aggregated at this layer to save the required power and BW. It has the capability of signal processing, data compression, coding, etc.

The transport stratum includes transport sub-layer and transport control sub-layer. The transport sub-layer contains access network and core transport network. The access network take care of end users' access to the network as well as collecting and aggregating the traffic towards the core network. The transport control sub-layer is further divided in two subsystems the Network Attachment Subsystem (NASS) and the Resource and Admission Control Subsystem (RACS) to provide the QoS, privacy, security, and authorization, as required for the USN applications. These elements provide transport control functionalities according to the standards [65] [66].



**Figure 4.1:** Next generation e-Health network architecture

The service stratum includes IMS service control sub-layer, USN middleware sub-layer, and the IMS service application sub-layer. It provides the platform for

enabling services to the user. It includes registration and session control functions. It includes three sub-layers: the service control sub-layer, the USN middleware sub-layer, and the service application sub-layer. The service control sub-layer is based on the standard IMS [6] and controls the authentication, routing, and database of the subscribers. This sub-layer provides the USN requirements needed including service profile, open service environment, security, and authorization.

The middleware sub-layer is an intermediate entity that provides functions commonly required by different types of USN applications and services. It receives requests from USN applications and delivers those requests to appropriate SNs. Similarly, USN middleware receives sensed data or processed data from SNs and delivers them to appropriate USN applications. USN middleware can provide information processing functions such as query processing, CA processing, event processing, SN monitoring and so on. In addition, it interfaces with the S-CSCF using SIP and is responsible of executing the different applications based on the Initial Filter Criteria (IFC), which represent the service profile of each customer.

There is a need for a CA server to automatically adapt the behavior of an application or service depending on the user current situation. These situations are any information that can be used to characterize the situation of an entity. This entity could be a person, place, or object that is considered relevant to the interaction between a user and an application, including the user and application themselves.

In this work, a new AS integrated with a CA server is developed to provide e-Health services. This integration eases services control and reduces the signaling required between both of them. Consequently, there is one centralized server, which provides a coherent environment and is responsible of services control. This AS/CA server can be owned by the network operator or hosted by an external service provider.

The USN middleware sub-layer contains also a private database for the e-Health services' subscribers. It is called the Electronic Health Record (EHR). It contains the initial sensors configuration settings, the collected monitored vital signs, the different patients' data files such as (X-Ray, tests results, prescriptions, etc.), emergency contacts, medical supervisors, medical history, and any other information related to the patient health. The proposal allows the patients to access the EHR. This enables them to change their details, update their emergency contacts, and upload files. Access to the EHR is provided through a Web Server (WS), which is implemented in the service application sub-layer or via an IMS client.

This sub-layer covers the SN management, service profile, open service environment, location based service support, and service privacy of the USN requirements.

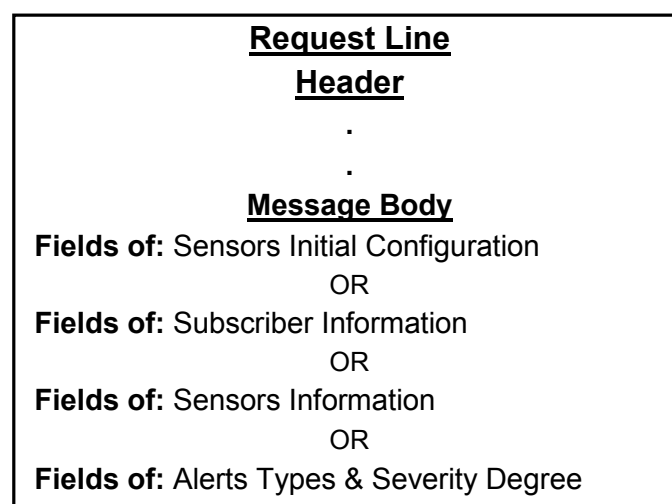
The Service Application Sub-layer contains a Presence Server (PS), which is used to follow and publish the patients' status in real-time to their emergency contacts as explained later in details. This addition allows informing selected persons by the emergency situation as soon as it occurs.

This sub-layer contains also a WS, which interfaces the patients' records. Through the WS, patients can change in their details, upload files, contact medical centers, doctors, etc.

#### 4.5 Signaling Scenarios

This section focuses on the IMS and SIP functionalities and does not cover the transport layer of the NGN, as there is no modification to its functions.

The section describes in details the initialization phase as well as the different applicable scenarios. It is to be noted that the SIP "Message" requests in these scenarios are used differently from their original use. The standard SIP "Message" requests are designed to carry content in the form of Multipurpose Internet Mail Extensions (MIME) body parts. Therefore, the proposal of this work: using a special format and data fields for the "Message" request body to carry data from/to AS/CA. These data may contain sensors initial configurations, sensors data, alerts, subscribers' information, etc. Figure 4.2 shows an example of the proposed data fields provided in the "Message" request body.



**Figure 4.2:** Proposed SIP "Message" request body for e-Health services

### 4.5.1 Initialization and Registration

Figure 4.3 shows the registration steps for a patient, which follows the standard IMS client registration detailed in [67]. Prior to IMS registration, or before starting any procedure related to the IMS operation, there are a number of prerequisites that have to be fulfilled.

First, the IMS operator (service provider) has to authorize the end-user to use the IMS service by signing a contract and having a subscription. Second, the IMS terminal needs to get access to an IP Connectivity Access Network (IP-CAN). Since IMS is access independent, the IP-CAN may be GPRS (Release 5), WLAN (Release 6), ADSL (Release 7), or LTE (Releases 8-13). The terminal needs also to acquire an IP address, which is usually dynamically assigned by the operator.

Third, the IMS terminal must discover the IP address of the IMS entity to which it will send the register request (P-CSCF). This process is called P-CSCF discovery. The P-CSCF will act as a SIP inbound/outbound proxy server and is allocated permanently for the duration of the registration.

Finally, the IMS terminal registers at the SIP application level to the IMS network by regular SIP registration. This registration is independent of registration with the IP-CAN (e.g. attachment to the GPRS network). The steps of the registration process is described as follows:

- The UE sends a SIP “Register” request (step 1) to the discovered P-CSCF. This request would contains, an identity to be registered and a home domain name (address of the I-CSCF).
- The P-CSCF processes the “Register” request (step 2) and uses the provided home domain name to resolve the IP address of the I-CSCF.
- The I-CSCF, in turn, will contact the HSS to fetch the required capabilities for S-CSCF selection (step 3) using the Diameter protocol. After S-CSCF selection, the I-CSCF forwards the “Register” request to the S-CSCF.
- The S-CSCF realizes that the user is not authorized. Thus, the S-CSCF retrieves the authentication data from the HSS using the Diameter protocol (step 6).
- The S-CSCF challenges the user with a “401-Unauthorized” response (step 8).
- The UE will calculate a response to the received challenge and send another "Register" request containing that response to the P-CSCF (step 11).

- The P-CSCF finds the I-CSCF and forwards to it the “Register” request (step 12) and the I-CSCF, in turn, will find the S-CSCF from the HSS by searching by the subscriber identity (step 13).
- The I-CSCF forwards the “Register” request to the proposed S-CSCF (step 15).
- The S-CSCF checks the subscriber response and, if it is correct, it downloads the user profile from the HSS (step 16) as it will be the responsible of executing the user-subscribed services.
- The S-CSCF accepts the registration by replying by a “200 OK” response (step 18) and at the same time the S-CSCF checks if the user has a subscription in any application as follows.

After the Patient’s registration completion:

- The S-CSCF evaluates the user’s IFC (step 21) and accordingly, it forwards the “Register” request to the AS/CA (step 22) as it finds the user is subscribed in a service or more and its execution is conditioned by the “Register” request.
- Based on the e-health algorithm saved in the AS/CA, it downloads the initial configurations, measurements thresholds, possible diseases’ situations, and patient’s emergency contact list from the EHR using the Hyper Text Transfer Protocol (HTTP) “GET” request (step 24).
- The AS/CA forwards the downloaded initial configurations and a copy the measurements thresholds to the USN Gateway in the body of a SIP “Message” request (step 26) according to the format in Fig. 4.2. So, the USN Gateway would be programmed by the patient’s suitable parameters, such as the periodicity of transmission, and the temporary transmissions when the measurements thresholds are violated.
- The next step, the AS/CA sends a “Subscribe” request (step 32) to the PS to be notified by the presence status of the persons in the downloaded patient’s emergency list (e-list). So, the AS/CA has the information of best way to get contact with the e-list when patient’s emergency cases occur.
- The PS sends back a “Notify” message (step 34) containing the current status of the e-list. The PS sends a “Notify” request to the AS/CA every time there is a status change in the e-list.



- At the same time, the AS/CA sends a “Publish” request (step 36) to the PS containing the current patient’s status, which can be exploited as an indication of alarm situations.

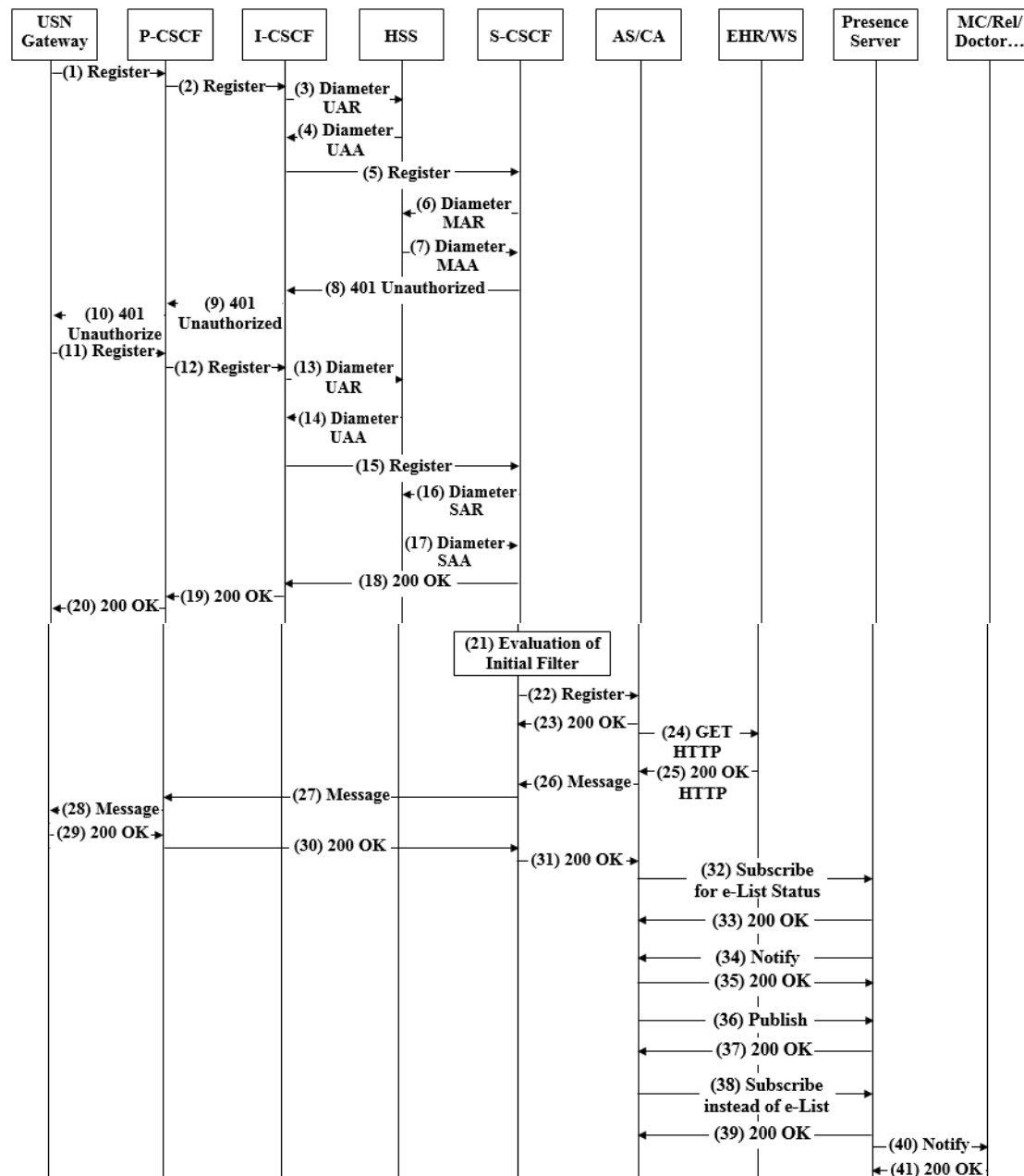


Figure 4.3: Registration and initialization scenario

It is to be noted here that the patient's status is not meant to be online or offline. Instead, it reflects the patient's health condition (normal, critical, emergency, etc.). Another important issue arises; the contacts in the patient's e-list which could be (MC: Medical Center, Rel: Relatives, Doctors, etc.) have to follow his status automatically and without their intervention. For so;

- The AS/CA subscribes on behalf of them to the patient's status by sending a “Subscribe” request (step 38) to the PS.
- Accordingly, they will be continuously updated of any status change via “Notify” requests (step 40) from the PS.

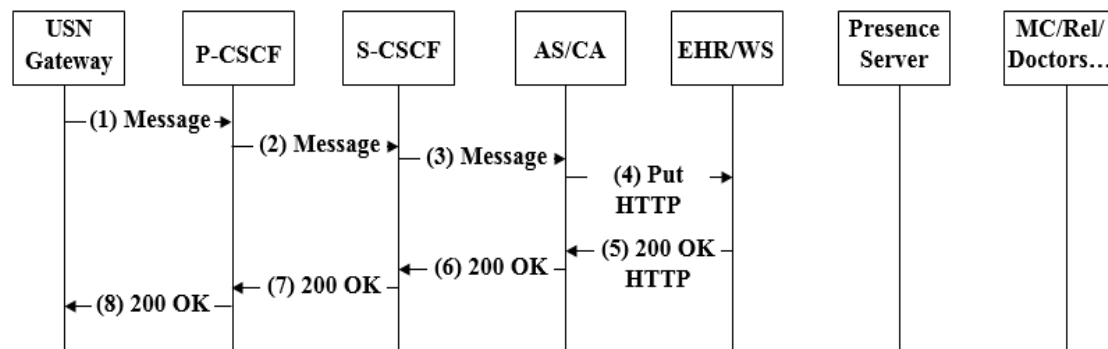
HTTP is proposed to be used between the EHR/WS and the AS/CA server. It is to be noted that every patient (e-Health subscriber), via the WS interface, can build his own contact list to be notified in case of emergency as mentioned before.

#### 4.5.2 First Scenario (Periodic Transmissions)

This Scenario proposes a simple case for transmitting periodic sensed information. The period to transmit regular collected data is determined from a timer value in the initial configuration received from the AS/CA during the initialization phase. The scenario steps are:

- The USN Gateway collects the sensed data from the sensors. When the data is ready for transmission, the USN Gateway puts the collected sensors data in the body part of a SIP “Message” request compliant to the format of Fig. 4.2 (step 1) and sends it to the AS/CA.
- The request is routed normally to the AS/CA, which stores the data in the EHR using HTTP “PUT” (step 4).

Figure 4.4 shows the scenario's signaling flow. The USN Gateway transmits the data to the EHR through the AS/CA and not directly, because the collected data has to be assessed and compared to specific thresholds to determine if there is an emergency case (more details in next scenario). These thresholds are set in the initial configuration file downloaded from the EHR during the registration and initialization phase. This task has to be controlled through the AS/CA and not the EHR as this later is only a database for storing, and it has no control or service algorithm as in the AS/CA. Another reason is the security issues, as the EHR must be hidden from non-trusted users' devices.



**Figure 4.4:** Periodic transmission scenario

### 4.5.3 Second Scenario (Emergency Case)

Figure 4.5 shows the emergency scenario. The emergency cases are triggered if the collected data values are out of the threshold range set in the initial patient's file that stored in the EHR and a copy is downloaded to the AS/CA. The interaction steps corresponding to these emergency cases start from (step 9) after saving the users' data into the EHR as follows:

- The AS/CA evaluates the collected values to the preset thresholds (step 9).
- If an emergency case is identified, the AS/CA updates the patient status in the PS using a “Publish” request (step 10) to be critical or emergency depending on the severity of the patient case.
- The PS updates, in turn, the emergency status in the patient's e-list by a “Notify” request (step 12).
- Simultaneously, an alert message is sent to these contacts. The AS/CA has two options to implement the informing depending on the contacts' IMS status: online or offline;
  - In case the contact person is online, the alert is sent using a SIP “Message” as mentioned in Fig. 4.2 (step 14) containing the current patient's data and its health severe degree.
  - In case the contact person is offline, the alert is sent using a Short Message Service (SMS) (step 16) through a mobile network operator containing the same patient's data.

The e-list IMS status is known since the AS/CA has already subscribed to their status during the initialization phase (step 32 in the registration and initialization scenario). Therefore, AS/CA is aware of the best way to contact the members of the e-

list. The e-list contacts could be relatives, treating doctor, medical center, ambulance, neighbors, and coworkers, etc.

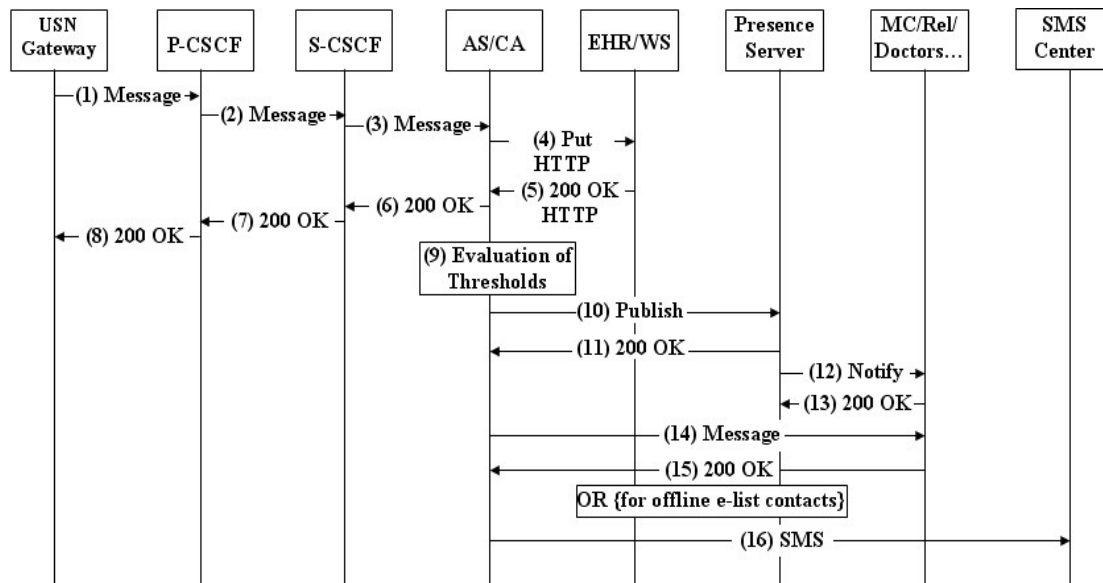


Figure 4.5: Emergency scenario

#### 4.5.4 Third Scenario

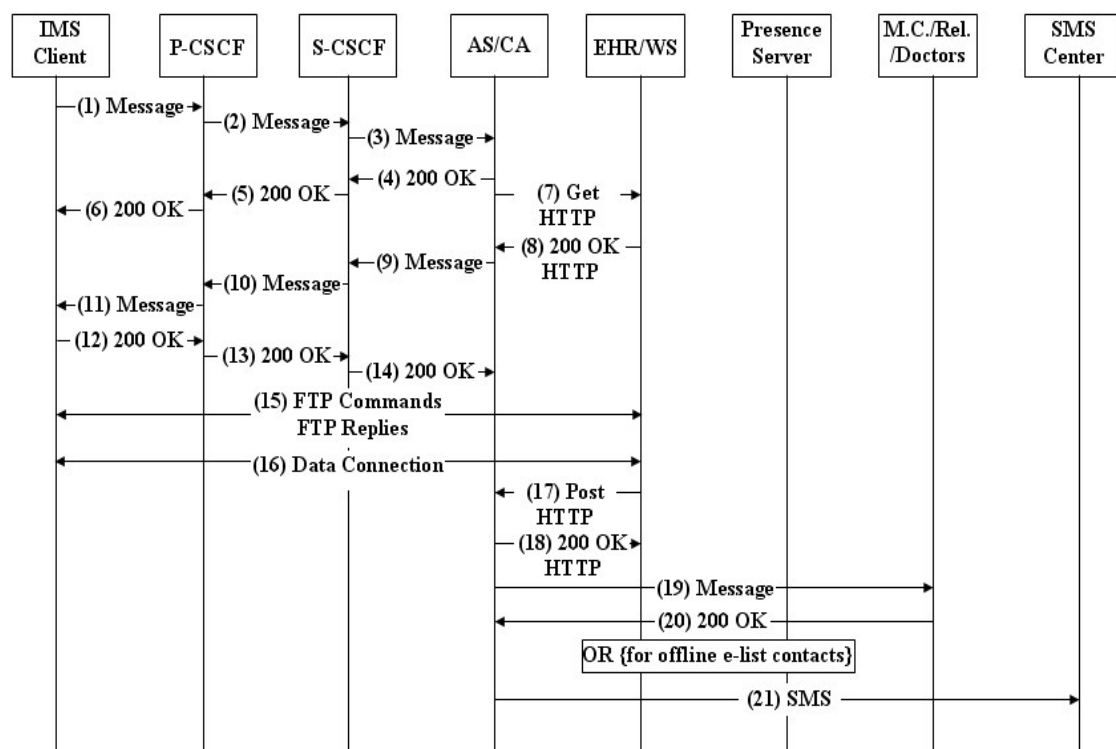
This scenario provides the case where there is a patient would like to upload file(s) to his EHR record. The file(s) could be of any type such as (scanned X-ray, ultrasound, magnetic resonance, etc.). There are two options for doing this. The loading is not terminated directly to the EHR, instead it is completed with the WS which interfaces the EHR for security issues.

The first option supposes the patient has an IMS client as shown in Fig. 4.6. So:

- When the uploader (the patient's IMS client) needs to upload file(s), he transmits a SIP "Message" request in the format of Fig. 4.2 (step 1) containing in its body part a request for the necessary upload information (URL, username, password) needed for activating the upload process that traverses through the P/S-CSCF until reaching the AS/CA.
- Once this request arrives at the AS/CA, it retrieves the needed information from the EHR by a HTTP "GET" request (step 7).
- The AS/CA forwards this information to the uploader in a SIP "Message" request (step 9).
- The uploader can now upload the file to the EHR according to the received settings using the FTP (step 15). The username and password sent in the

previous step are temporary and the EHR will change it every time the patient requests for uploading file(s). This is for securing the system.

- After uploading the file successfully, the EHR informs the AS/CA of the upload termination and the type of the file uploaded using HTTP “POST” request (step 17).
- According to the patient’s customized service algorithm, the AS/CA informs the concerned persons (e.g.: doctor, medical center, relatives, etc.). This is done, depending on the contacts' IMS status, using a SIP “Message” request (step 19) or by SMS message (step 21) depending on their current status as explained in the previous scenario.

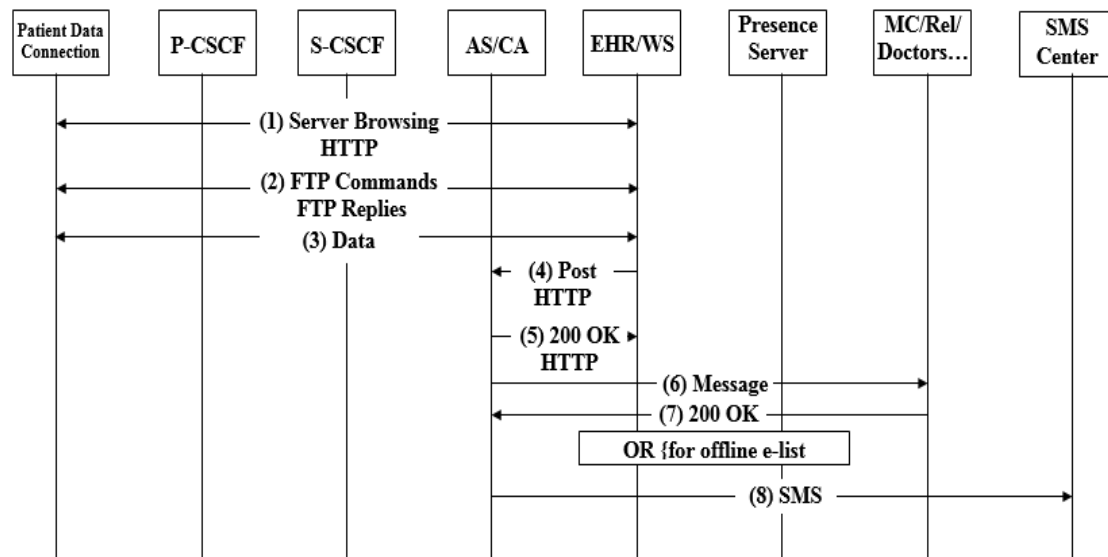


**Figure 4.6:** Uploading patients’ files using an IMS client

The second uploading option is shown in Fig. 4.7. In that case, the uploader does not use an IMS client to access the WS, instead it uses FTP protocol, so:

- The patient uses HTTP to browse the WS (step 1), and submits his file directly using the FTP (steps 2 and 3) without the need to pass through the IMS network. He needs only a data connection to the WS to access his record in the EHR.
- As in the first option, the EHR informs the AS/CA of the upload termination using HTTP “POST” request (step 4) containing the type of the uploaded file.

- The AS/CA, in turn, informs the concerned persons using a SIP “Message” request (step 6).
- The AS/CA will send a SMS (step 8) in case the e-list persons status’ is offline.

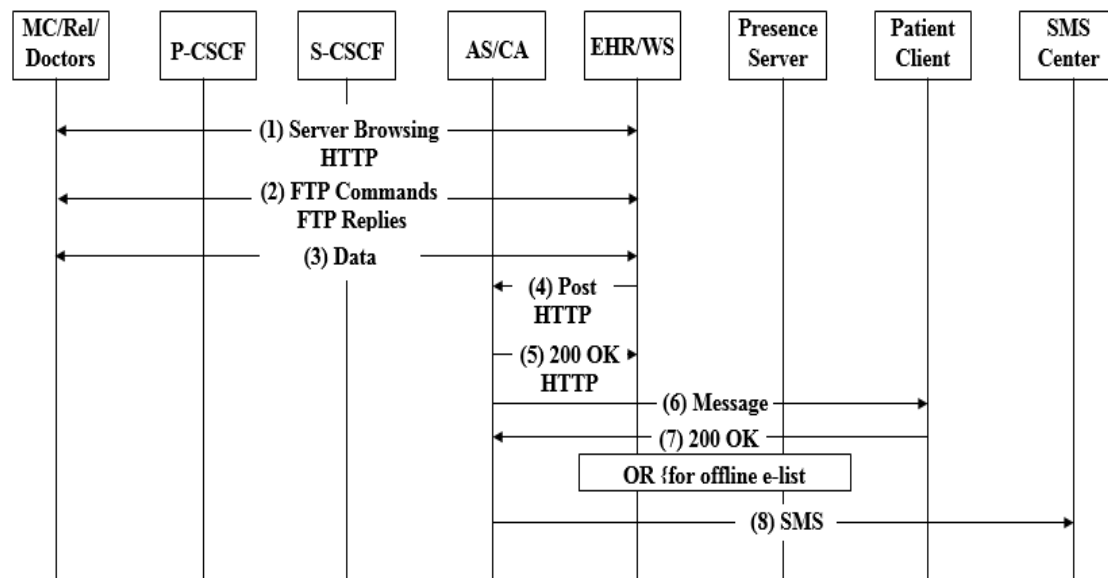


**Figure 4.7:** Uploading patients’ file(s) directly through the WS

#### 4.5.5 Fourth Scenario

This scenario is similar to the previous one. However, the uploader here is not the patient. It could be (the treating doctor, the scanning center, the tests laboratory, etc.) as shown in Fig. 4.8. Consider the patient’s doctor would like to send or update the prescription of the patient or the lab wants to send the test results:

- They will connect directly to the WS using their accounts credentials and start browsing the patient’s record using HTTP (step 1).
- The sender Upload the new file(s) or update the existing patient’s information (step 3). The sender can also identify the urgency of the updated data.
- The EHR informs the AS/CA of the new file upload or the information change using HTTP “POST” request (step 4) containing the type of the uploaded data.
- The AS/CA, in turn, informs the patient using a SIP “Message” request (step 6)
- In case the patient client is offline, a SMS message can be sent instead (step 8).



**Figure 4.8:** Changing in the patients database/uploading files through the WS

## 4.6 Potential Applications

Another application for such a service could involve the pharmacies, insurance companies, and hospitals. The patient can ask for the medicines in the prescription from the AS/CA. This later would search in the pharmacies database for the nearest one to the patient's residence and inform him. It can also order it automatically from the pharmacy to be delivered to his premises. The service can also be used to set an appointment for the patient with his doctor or at the medical center. In case he needs to be transferred to the hospital by an ambulance service due to emergency case or for his regular medical visit, he can ask for that and the AS/CA will reserve the ambulance for him to the nearest medical center or hospital.

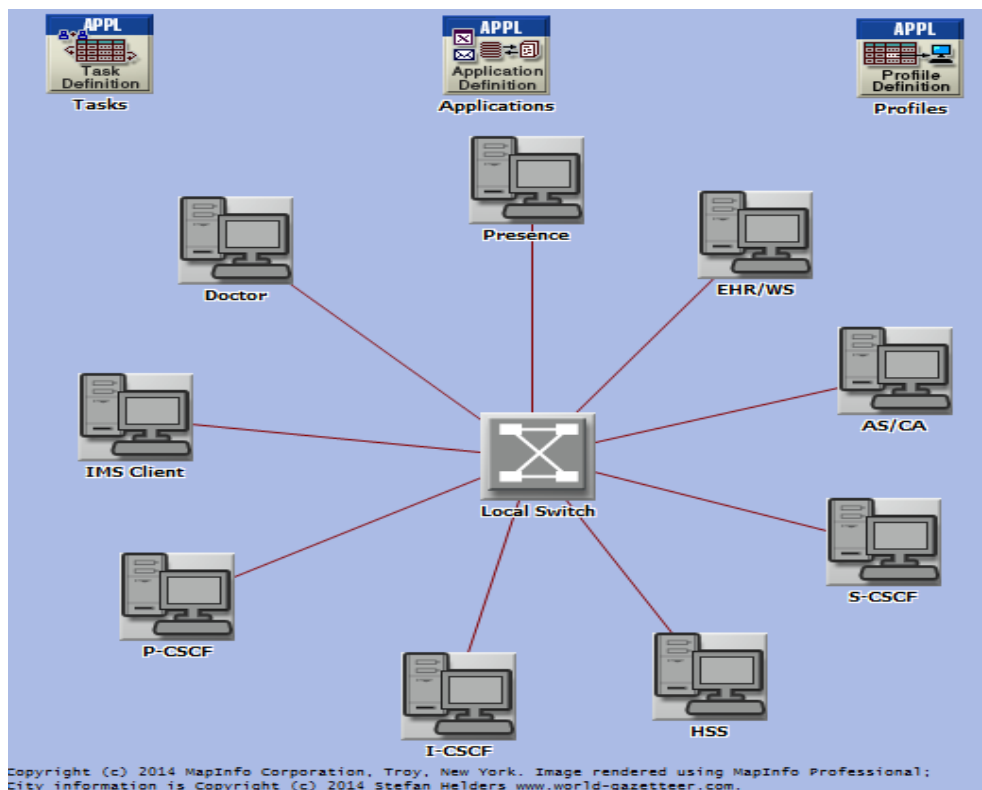
All these application require that the EHR should contain a complete database for patients, medical centers (MCs), hospitals, insurance companies, pharmacies, etc.

## 4.7 Performance Evaluation

In this section, the performance evaluation of the proposal is presented. For the evaluation of the system, Different scenarios using the simulation tool (OPNET Modeler 14.0) are implemented. The objective of this simulation is to study the applicability and reliability of the proposed work under different conditions such as number of users and links BWs. As the thesis concentrates on the IMS platform and the SIP signaling protocol and as the NGN transport layer has no change in the proposed

model, the performance section focuses on the IMS evaluation. The simulation model passes by sequential steps as follows:

- Build the proposed network architecture (IMS servers) using OPNET simulation tool as shown in Fig. 4.9 and assign the transmission delay to the servers' connections according to the values of Table 4.1.
- Create the developed signaling flow using the graphical OPNET application task tool (ACE whiteboard) as shown in Fig. 4.10. The servers are called tiers in ACE whiteboard.
- Assign the processing time of each server (tier) in the ACE whiteboard model according to Table 4.1 as mentioned in [68].
- Import the ACE whiteboard model into the main project model.
- Assign the server function of each ACE model tier corresponding to the developed signaling flows.

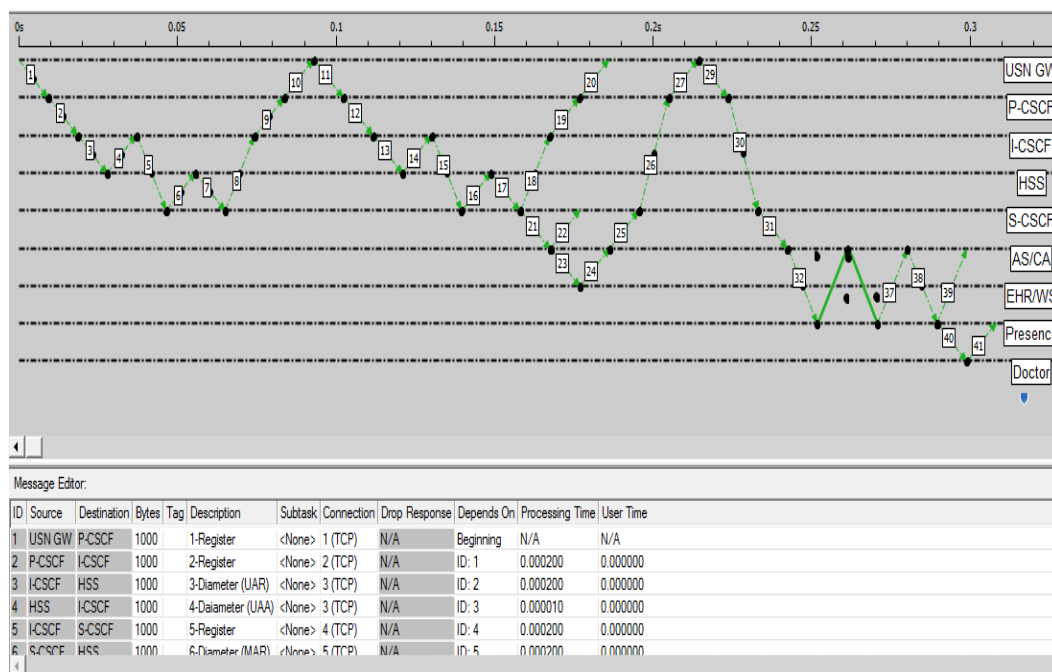


**Figure 4.9:** Network architecture built using the OPNET simulation tool



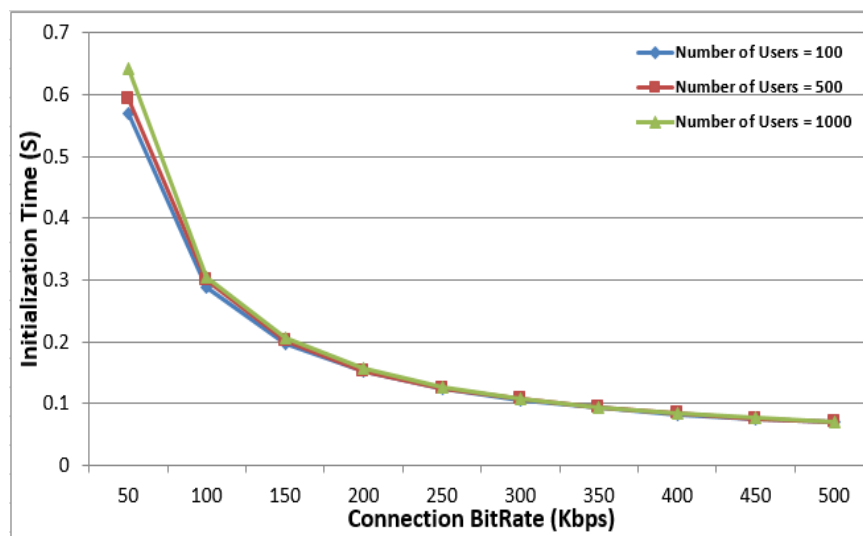
**Table 4.1:** IMS entities processing and transmission times

Parameters		Duration
Process time (microsecond)	UE	200
	P/S/I-CSCF	200
	HSS	10
Transmission delay (microsecond)	UE/P-CSCF	5,000
	other links	200

**Figure 4.10:** ACE whiteboard model for the registration and initialization signaling flow

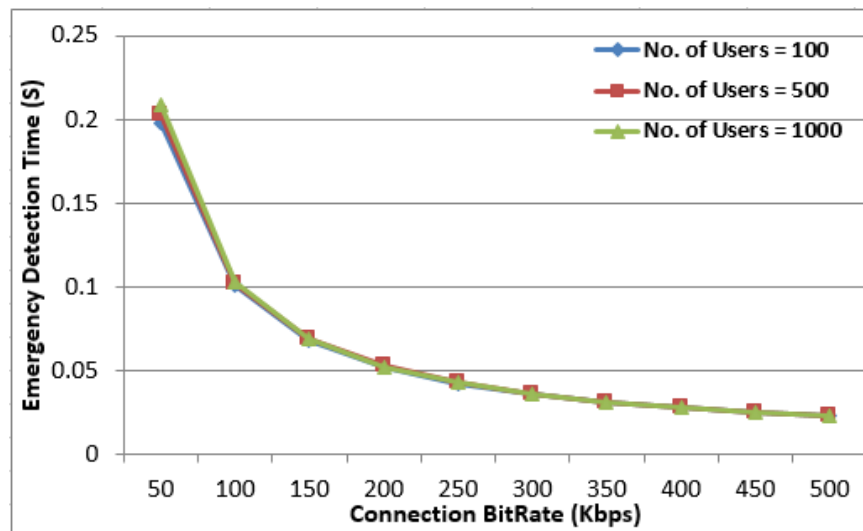
**Simulation 1:** the first simulation observes the initialization and registration scenario. The effect of increasing the BW of the link between the USN Gateway and the network on the service initialization time is studied. The initialization time is defined as the time spent between the “Register” request message (step 1) and the last sent message “200 OK” (step 41) of the signaling flow in Fig. 4.3. The simulation is repeated several times with the increase of the BW from 50 to 500 Kbps in steps of 50 Kbps. The initialization time was calculated for different number of users varying from 100 to 1000. Figure 4.11 shows the collected results. The simulation shows that the delay of the service initialization time decreases with the increase of the connection BW. On the other hand, the number of users has a negligible effect for BWs higher than 150 kbps and a small

effect for BWs less than 150 kbps. This is because the connection bit rate required for each user to register and activate his e-Health subscription on the IMS is low according to the signaling proposed in Fig. 4.3. In conclusion, the dominant factor in calculating the service initializing time of the proposed signaling flow, which is applied on the IMS platform is the BW.



**Figure 4.11:** The registration time at different connection speeds

**Simulation 2:** the emergency detection scenario is evaluated by simulating the proposed signaling flow shown in Fig. 4.5. The simulation was run for different USN Gateway connection BWs ranging from 50 to 500 Kbps for 100, 500, and 1000 users respectively. The collected results are shown in Fig. 4.12. The simulation result shows that the maximum detection time of an emergency case is 0.21 seconds, which is perfect for such these urgent situations. Moreover, the detection time decreases exponentially as the USN gateway connection BW increases and is not affected significantly by the number of users. As shown in the figure, the number of users has the minimum effect on the delay. This is because the BW needed for the process is low, which proves the reliability of the developed signaling flow. Moreover, even if the user's connection is slow and the delay increases for more than 0.21 seconds, this delay is still within an acceptable margin for implementing the emergency scenario, which still grants a fast notification and reaction for the health urgent cases.

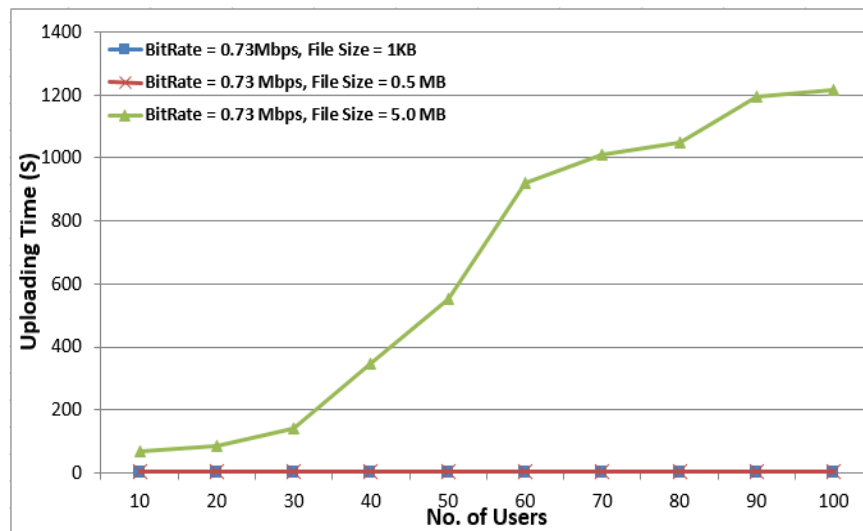


**Figure 4.12:** The emergency detection time at different connection speeds

**Simulation 3:** to investigate the time required to upload a patient's file to the EHR server through the WS, the flow shown in Fig. 4.7 is simulated. The number of users increased from 10 to 100 in steps of 10 and the simulation repeated for different file sizes as shown in Table 4.2. The BW of the link between the USN Gateway and the network was set to 0.73 Mbps corresponding to HSUPA (category 1) connection rate. Figure 4.13 shows the obtained results. The figure clearly shows that at small file sizes of 1 KB and moderate file sizes of 0.5 MB, the delay is almost constant with the increase of the number of users. These files sizes represent the USN sensed information or patient analysis files and the average size of the x-ray or image files respectively. On the contrary, for large file sizes (5.0 MB), which represent an average video file size, the delay increases with the number of users. Hence, the proposed solution is very effective in case of small or medium files representing data and radiography files. On the other hand, video files will suffer of delay depending on their sizes. Thus, the dominant factor of the delay is the uploaded file size.

**Table 4.2:** Uploaded Files Sizes

File Type	Purpose	Average File Size
Text	Sensed Information Medical Analysis...etc	A few KB
Image	X-Ray Magnetic resonance...etc	0.5 MB
Video	Ultrasound...etc	5.0 MB

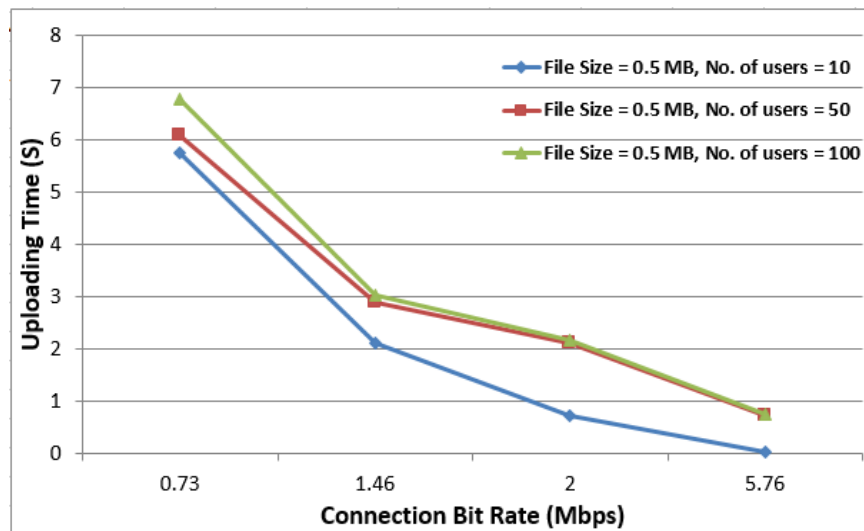


**Figure 4.13:** File uploading time at different number of users

**Simulation 4:** for the same scenario of Fig. 4.7, the effect of the USN Gateway connection BW on the upload time is studied. The simulation was run several times for different connection bit rates corresponding to the different HSUPA categories standard speeds as stated in Table 4.3. It is to be noted that the HSUPA Category 4 speed is not simulated, as it is not being widely implemented. The file size was assumed to be 0.5 MB in this simulation. Figure 4.14 shows the results. The simulation proves that for a fixed number of users and file size, the delay decreases with the increase of the users' connection speed.

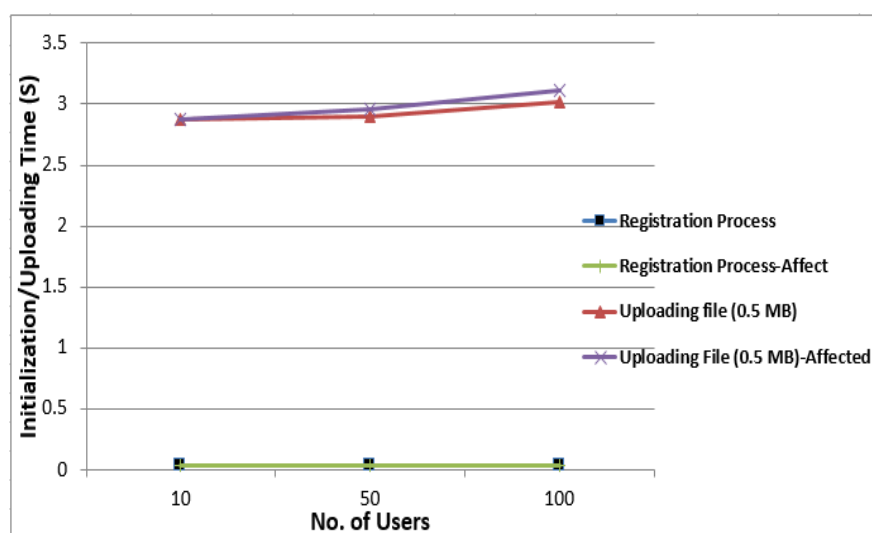
**Table 4.3:** HSUPA Categories Speed

HSUPA Category	Max Uplink Speed
Category 1	0.73 Mbit/s
Category 2	1.46 Mbit/s
Category 3	1.46 Mbit/s
Category 4	2.0 / 2.93 Mbit/s
Category 5	2.0 Mbit/s
Category 6	2.0 / 5.76 Mbit/s



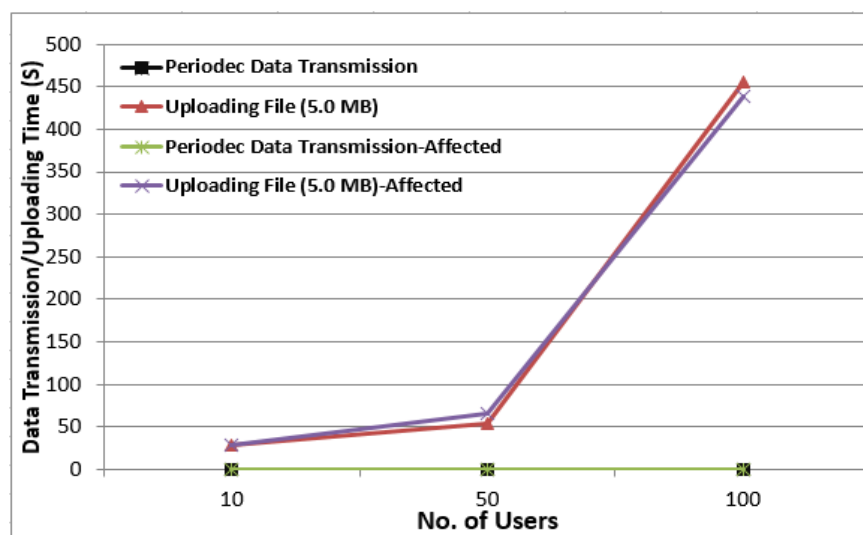
**Figure 4.14:** File uploading time at different connection speeds

**Simulation 5:** the initialization process of Fig. 4.3 and the upload scenario of Fig. 4.7 were combined together in one final simulation to study their effect on each other. The simulation contains 10 users performing the initialization process simultaneously with 10 other users uploading files of size 0.5 MB. The USN Gateway connection BW is 1.46 MB/S (HSUBA Category 2). The simulation was repeated for 50 and 100 users. The results are shown in Fig. 4.15 along with the results of the initialization and upload times collected from the previous simulations where the two processes were simulated separately. The results show a slight effect on the upload time, which could be neglected. On the other hand, there is no congestion effect on the users registering to the network even when there are other users uploading files. This is because the registration process does not mandate high connection speed.



**Figure 4.15:** The effect of uploading files scenario on the registration scenario

**Simulation 6:** finally, the mutual effect of combining the traffic of uploading files of size 5.0 MB and the periodic sensors' data transmission according to the signaling flow of Fig. 4.5 is investigated. The USN Gateway connection BW is 1.46 MB/S (HSUBA Category 2). Each type of traffic was simulated separately and then combined together. The results are shown in Fig. 4.16 for separate and combined traffic types. It is concluded that there is almost no mutual effect as the periodic data size is very small and does not require high bit rate. Therefore, the emergency scenarios reliability will not be affected by the simultaneous transmission of other files.



**Figure 4.16:** The effect uploading files scenario on periodic data transmission scenario

## 4.8 Conclusion

Despite that, e-Health is one of the USN promising services; there is no complete solution to provide this service. In this chapter, an architecture for the integration between USN and IMS-based NGN is proposed to provide an infrastructure suitable for building USN applications. Also, a complete and detailed solution is proposed including the inter-entities signaling to provide e-Health services in the USN environment fulfill the service requirements of the USN applications according to the ITU recommendations. The new architecture uses the existing IMS-based NGN functional entities adding to them new servers such as the e-Health AS integrated with a CA and the EHR integrated with a WS. Four detailed emergency scenarios are presented showing the complete execution of the service and the interaction between the different entities.

The evaluation section of the proposal proves the ability to implement the e-Health application and the reliability of the new proposed scenarios signaling models. The results show: first, the initialization time and the emergency detection time are very short (0.64 S, 0.21 S) respectively even using a low BW and large number of active users. Second, the file uploading time is affected essentially by the file size and the available BW. However, since file transfer is not delay sensitive, this is not a major issue if high BW connections are not available. Finally, combining different types of traffic together does not have a significant effect on the performance of the system.

On the other hand, a dedicated e-Health application for patients only is not satisfactory, human beings need to be in safe everywhere and every time, which is the aspiration behind the USN. Moreover, there is a rapid grown in ITS and specially using VANETS. Therefore, the global goal is to complete the safety environment to anyone and everywhere. In the next two chapters, a proposal of building safety applications in VANETS is introduced. This proposal utilizes the benefits of integrating USN and VANET. USNs and VANETS are proposed to be integrated and controlled by IMS-based NGN as will be described in chapter 5 & 6.

Furthermore, safety applications are time sensitive. Therefore, it is essential to validate the reliability of implementing the proposed safety application in VANETS. In chapter 5, a novel analytical solution is developed to model the VANET's link connectivity between vehicles and calculate the communication delay between any two nodes along the roads. In chapter 6, an analytical solution is developed to model the IMS servers' performance and measure the delay time to implement the proposed application. These two analytical models helps to calculate the RTT to validate the use of IMS as a controller sub-layer for real time applications in VANETS, and hence the reliability of implementing the proposed safety application signaling model.

## Chapter 5

### On the Shortest Path in Vehicular Network

#### Contents

<b>5.1 Introduction.....</b>	<b>75</b>
<b>5.2 Related Work.....</b>	<b>77</b>
<b>5.3 VANET Link Connectivity Model .....</b>	<b>78</b>
5.3.1 Model and Assumptions.....	78
5.3.2 The Inter-distance Process .....	79
5.3.3 Recall on the Results of Liu and Shi in [80] used in [70].....	81
5.3.4 Problem Formulation.....	82
5.3.5 Problem Solution.....	83
5.3.6 V2V Multi-Segment Model .....	85
<b>5.4 V2V Link Model Validation.....</b>	<b>86</b>
<b>5.5 Conclusion.....</b>	<b>93</b>

#### 5.1 Introduction

One of the thesis main interests is to exploit the benefits of the USN for implementing safety applications. These applications are proposed to be integrated and controlled by the IMS-based NGN. Due to the rapid evolution in the ITS particularly in VANETs and the importance of providing safety on the roads specially for the countries suffering of high number of accidents per year like Egypt, a safety application in VANETs using the IMS-based NGN as the service controller sub-layer is proposed.

Safety applications are delay sensitive. Therefore, in this chapter and in chapter 6 two analytical models are introduced to calculate the time of implementing the proposed application and hence validate the proposal. In this chapter, the analytical solution developed models the link connectivity between vehicles in roads. This model is used to calculate the number of hops between the vehicle that detects an event and the nearest RSU and hence calculate the communication delay expected between these



two nodes. The calculated delay time is used as a part in the validation safety applications in VANETs controlled by IMS-based NGN.

Moreover, evaluating VANET protocols is generally complex and difficult as it requires to consider many parameters. Ideally, a VANET model should take into account at least accurate radio models, accurate road traffic models, and protocol models. That is why, most of the time protocols are evaluated by simulation. Nevertheless, models given connectivity probabilities in function of the distance between a sender and a receiver, the time to route the information from a source to a destination or the number of hops in the shortest path would avoid complex and long simulations. For example, it is interesting to know the probability that a message emitted from a source can reach a vehicle located at a certain distance ahead of the road. If this probability is positive, it is required to know how much hops are necessary to reach the destination, and how long time is needed. Connectivity probabilities have been already studied (e.g. [70]) but the process of the number of hops, when following the shortest path, is not exactly known (there are bounds in [71]). The goal of this research is to provide a first insight in this direction.

In this contribution, the number of hops in a connected component is studied. At a given time, vehicles are spread on the road, separated by random distances. Considering a solid disk propagation model, which may be refined later, vehicles can communicate if the inter-distance between them is less than a certain coverage radius. In this case, vehicles can constitute connected components. It is required to model the distribution of the number of hops of the maximal shortest path in a connected component. It is the shortest path between a vehicle at an end of the connected component to another vehicle at the other extremity. There is a routing protocol used to allow only vehicles on the shortest path to retransmit packets. In other words, if two vehicles receive at the same time the same packet from a sender, only the farthest one under the sender's coverage forwards the packet.

The probability of the number of hops in the maximal shortest component could be given conditionally to the distance separating both ends of the component. Moreover, it is quite a hard task and in the thesis the simpler problem of the probability of the number of hops is addressed whatever the size of the connected component is. It is a first step. Modelling the maximal shortest path whatever its distance is can be yet directly used in combination with the connectivity probability to evaluate the number of hops in a diffusion protocol for instance. Also, assuming a path exists between a

sender and a receiver, it can be used to approximate the number of hops between them located at a certain distance by multiplying the hop density by the distance separating these two nodes. Using the results obtained, the hop density, which is the average number of hops in a connected component divided by the average size of the connected component, can be estimated.

Next section reviews the related work of modeling the link connection between vehicles in roads.

## 5.2 Related Work

Regarding the VANET modeling, when the network is sparse, the information propagation speed may depend on the vehicle speed and the network may work in a delay tolerant fashion. In [72] and [73], models were presented for delay tolerant networks or to investigate the impact of disconnections in vehicle networks on the information propagation. These are interesting results but in the present work, only real-time applications are considered.

The connectivity in VANETs was widely studied as in [74], [75], and [76] where the connectivity probabilities were derived. In [77], authors proposed an analogy by which the ad-hoc network connectivity is modeled by a  $G/D/\infty$  queue. In [70], the authors used this analogy to derive the number of clients in a connected component of vehicles in a VANET and what they called the connectivity distance, which is the length of a vehicle connected component. In [77], authors investigated the effect of channel randomness on connectivity, with particular emphasis on the effect of lognormal shadowing and Rayleigh fading phenomena. The connectivity analysis had been extended to the case of a Nakagami fading channel in [78]. In [79], authors studied the minimum transmitted power necessary to ensure network connectivity in a VANET under BER requirements.

These papers provide insightful results on connectivity analysis. However, they give no detail on the number of hops in the shortest path of a vehicle connected component, which is important to estimate propagation delays. In [80], the multi-hop packet delivery was approximated through an effective BW approach, which takes represented the traffic parameters approximated by average ON and OFF periods. In [81] and [71], the connectivity and the number of hops through the shortest path were exactly modeled. Unfortunately, the results were given as recursive formula, which

makes it difficult to perform the analysis as function of network parameters. The number of hops through the shortest path in a connected component in VANETs was calculated as an explicit expression of the z-transform of its probability that is given for medium and dense networks. This model is used to derive the access delay.

## 5.3 VANET Link Connectivity Model

### 5.3.1 Model and Assumptions

The model is an extension of [70] where the authors calculate the connectivity probability between two nodes as a function of the inter-distance between them. This model is extended to calculate the number of nodes in the shortest path between two nodes. The approach consists of estimating the hop density on a connected set to estimate the number of nodes in the shortest path between two vehicles separated by a certain distance. For this goal, the number of hops is calculated on the largest shortest path in the connected set, which is the number of hops in the shortest path from the start of the connected component to its end divided by the spread of the connected set. In order to calculate the number of hops in the largest shortest path and as in [70], the same analogy presented in [77] is used, where the idea is to notice that the number of vehicles in VANET connected component is equal to the number of clients in a busy period  $M/D/\infty$  queue. The method to calculate the probability distribution of the number of clients in a busy period  $GI^X/D/\infty$  queue (of which  $M/D/\infty$  queue is a particular case) is given in [82].

Similar to [82], a free flow of vehicles traffic is considered on a straight road with speeds distributed according to a truncated normal distribution. The minimum and maximum speeds are  $V_{min}$  and  $V_{max}$ . Their mean and standard deviation are  $\mu$  and  $\sigma$  respectively. Note that if the vehicle transmission range  $R$  is sufficiently large compared to the road width  $L$ , the commonly used assumption of modeling a multiple lane road is modeled by a straight line with vehicles spread is highly acceptable. The vehicles arrive at position 0 of the road according to a Poisson process with rate  $\lambda_a$ . As proved in [70], the inter-distance of the vehicles at any given time is exponentially distributed with the following rate:

$$\lambda = \lambda_a \int_{V_{min}}^{V_{max}} \frac{1}{v} \frac{\frac{2}{\sigma\sqrt{2\pi}} e^{-\frac{1}{2}\left(\frac{v-\mu}{\sigma}\right)^2}}{\operatorname{erf}\left(\frac{V_{max}-\mu}{\sigma\sqrt{2}}\right) - \operatorname{erf}\left(\frac{V_{min}-\mu}{\sigma\sqrt{2}}\right)} dv \quad (5.1)$$

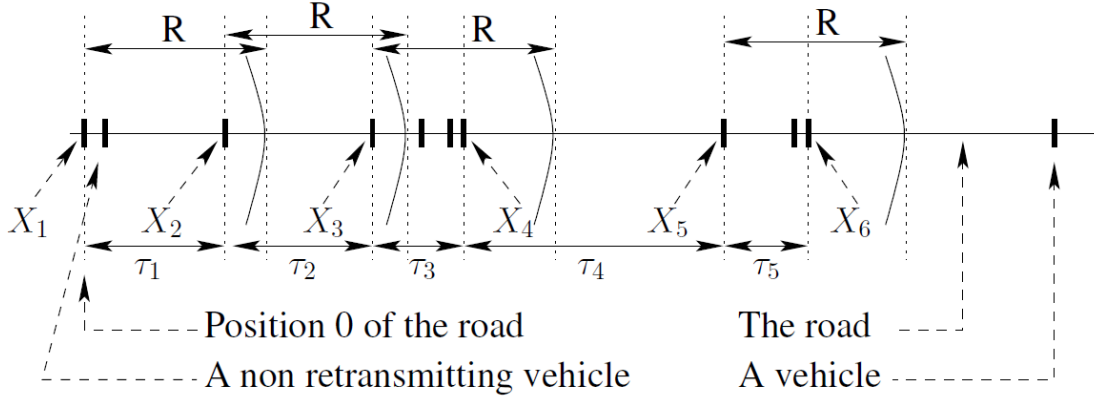
Also as in [70], to study the connectivity, the equivalent infinite server queueing model presented in [77] is used. The authors proved that the problem of connectivity of wireless nodes at a given time and with the solid disc transmission range model is equivalent to the problem of calculation of duration and the number of clients in a busy period in the  $G/D/\infty$  queue. This equivalence is in terms of number of wireless nodes in a connected cluster or length of connected path. The later corresponds to the former where the clients are replaced by vehicles, the time is replaced by the distance, and the communication range replaces the service time.

By using the results given in [82] on the probability generating function of the number of clients in a busy period and on the Laplace transform of the busy period duration, Yousefi et al. characterize in [70] the number of clients in a vehicle connected component and the connectivity distance, that is the length of a vehicle connected component.

Here, the same approach modeling the connectivity in terms of the  $GI^x/D/\infty$  is adapted. Nevertheless, since the number of hops is considered on the shortest path, it must not take into account all the vehicles on the road but only the retransmitting nodes. Thus, the input process of the queue is no more the Poisson process described in [70], but a sampled process on this Poisson process. As will be seen in the next section, it is a Markovian process.

### 5.3.2 The Inter-distance Process

To calculate the inter-distance between the retransmitting vehicles on the road, a shortest path is assumed between them as in Fig. 5.3. Let  $X_1, X_2, \dots, X_n$  be the retransmitting vehicles.  $X_{n+1}$  is the farthest vehicle under  $X_n$ 's coverage, or the next node after  $X_n$  if the distance between  $X_n$  and  $X_{n+1}$  is larger than  $R$ . If  $X_{n+1}$  is the farthest vehicle under  $X_n$  coverage, it is assumed to retransmit  $X_n$  packets even if there are another vehicles between them.



**Figure 5.1:** Vehicles connected component according to the shortest path

Let  $\tau_n$  be the distance between node  $X_n$  and node  $X_{n+1}$ . Let  $N[a; b]$  be the number of vehicles between positions  $a$  and  $b$ . When  $\forall x_1 \leq R$ , the probability function of  $\tau_1$  is given by:

$$\begin{aligned}
 F_{\tau_1}(x_1) &= P(\tau_1 \leq x_1) \\
 &= P(N[X_1; R] = 0 \cap N[0; R] \geq 1) \\
 &= P(N[X_1; R] = 0 \cap N[0; x_1] \geq 1) \\
 &= e^{-\lambda(R-x_1)}(1 - e^{-\lambda x_1})
 \end{aligned} \tag{5.2}$$

When  $x_1 > R$ , it is:

$$F_{\tau_1}(x_1) = 1 - e^{-\lambda x_1} \tag{5.3}$$

The probability function of  $\tau_n$  knowing  $\tau_{n-1} = x_{n-1}$  in the case of  $\tau_{n-1} > R$  is the same as  $\tau_1$ . When  $x_n \leq R$ , the probability function of  $\tau_n$  knowing  $\tau_{n-1} = x_{n-1}$  and  $\tau_{n-1} \leq R$  is given by:

$$\begin{aligned}
 F_{\tau_n/\tau_{n-1}}(x_n, x_{n-1}) &= P(\tau_n \leq x_n/\tau_{n-1} = x_{n-1} \cap \tau_{n-1} \leq R) \\
 &= e^{-\lambda(R-x_n)} - e^{-\lambda x_{n-1}}
 \end{aligned} \tag{5.4}$$

and in the case  $x_n > R$ :

$$F_{\tau_n/\tau_{n-1}}(x_n, x_{n-1}) = 1 - e^{-\lambda[x_n - (R - x_{n-1})]} \tag{5.5}$$

From Equations (5.2), (5.3), (5.4), and (5.5), it can be observed that the distance between the retransmitting vehicles on the shortest path is a Markovian process. In the rest of this section, it is assumed without loss of generality, the first retransmitting vehicle  $X_l$  at the beginning of a connected component.

### 5.3.3 Recall on the Results of Liu and Shi in [82] used in [70]

Liu and Shi consider a  $GI^X/G/\infty$  queue whose customers arrive in groups with generating function  $A(Z)$ . These customers are separated by inter-arrival times  $\tau_n$  of a distributed function  $F(x)$  and service time  $H(x)$ .  $Y_n$  is the number of clients in the  $n^{\text{th}}$  group and  $T_n$  is the time necessary to complete the services of the  $n^{\text{th}}$  group.  $K(x) = A(H(x))$  is the distribution function of  $T_n$ . In this case, that shows that the z-transform of the distributed function of the number of clients  $N_b$  in a connected component is:

$$\begin{aligned} & \sum_{k=1}^{+\infty} P(N_b = k) Z^k \\ &= \sum_{n=1}^{\infty} [A(z)]^n \int_0^{\infty} \dots \int_0^{\infty} \prod_{i=1}^{n-1} \{ [K(\sum_{j=i}^n x_j) - K(x_i)] dF(x_i) \} K(x_n) dF(x_n) \end{aligned} \quad (5.6)$$

This is true because the probability distribution of the number of customers served in a busy period is:

$$\begin{aligned} P(N_b = k) &= \sum_{n=1}^{\infty} P(\sum_{i=1}^n Y_i = k) \times \\ & P(\tau_i \leq T_i < \sum_{j=i}^n \tau_j, (i = 1, \dots, n-1), \tau_n > T_n) \end{aligned} \quad (5.7)$$

Taking the generating function of Eq. (5.7) and noting the discrete convolutions involved in that generating function, Eq. (5.6) can be obtained.

Also, in the special case of the  $GI^X/D/\infty$ ,  $K(x) = 1$  if  $x \geq R$  and 0 otherwise, so Eq. (5.6) becomes:

$$M_1(z) = \sum_{n=1}^{\infty} [A(z)]^n \int_{x_{n-1}=0}^R \dots \int_{x_{n-1}=0}^R \int_{x_n=R}^{\infty} \prod_{i=1}^n dF(x_i) \quad (5.8)$$

And thus Liu and Shi prove that formula (5.6) simplifies into:

$$M_1(z) = z \frac{1-F(R)}{1-zF(R)} \quad (5.9)$$

Liu and Shi present the Laplace transform of the busy period for the  $GI^X/D/\infty$  using the same arguments that reduce to:

$$\mathcal{L}(f_d)(s) = \frac{e^{-sR}(1-F(R))}{1 - \int_0^R e^{-sx} dF(x)} \quad (5.10)$$

The authors of [70] rely on Eq. (5.9) and Eq. (5.10) to derive an upper bound for the tail probability of the number of hops in the connected component:

$$P(N_b \geq h) \leq (1 - e^{-\lambda R})^h \quad (5.11)$$

The average distance of vehicles connected component  $L_{cc}$ , is equal to the average length of the busy period as follows:

$$\mathbb{E}[L_{cc}] = \frac{1 - e^{-\lambda R}}{\lambda e^{-\lambda R}} \quad (5.12)$$

### 5.3.4 Problem Formulation

Due to the independence of the inter-arrivals of the  $GI^X/D/\infty$ , the multiple integral in Eq. (5.8) can be easily simplified to obtain Eq. (5.9). However, in this assumed case, considering the shortest path leads to a Markovian process as already explained above in section 5.2.2.

Thus, the process of the inter-distance between the vehicles is not an independent process, but a Markovian process. The authors of [70] rely on the results in [82] about the  $GI^X/D/\infty$ , where the arrivals are assumed independent. Consequently, to compute the probability of the number of vehicles in a connected component, the results given in [70] is not compatible with the new process description. That is why it is rolled back to the approach initiated in [70] to adapt the model according to the Markovian arrival process. Thus, the results presented in [82] cannot be directly applied but they must be adapted to the non-independent case.

#### **Theorem 1:**

In the case of Markovian inter-distance process that is denoted by  $F_{\tau_i/\tau_{i-1}}(x_i, x_{i-1})$ , the cumulative distribution function of  $\tau_i$  knowing  $\tau_{i-1}$ , the probability to have  $k$  vehicles in a connected component is:

$$P(N_b = k) = \int_{x_1=0}^R \int_{x_2=R-x_1}^R \dots \int_{x_{k-1}=R-x_{k-2}}^R (1 - F_{\tau_k/\tau_{k-1}}(R, x_{k-1})) dF_{\tau_1}(x_1) \prod_{i=2}^{k-1} dF_{\tau_i/\tau_{i-1}}(x_i, x_{i-1}) \quad (5.13)$$

**Proof:** By following the same approach as in [82] but using the Markov property, it is obtained that:

$$\begin{aligned} P(N_b = k) &= P\left(\forall_i \in \llbracket 1; k-1 \rrbracket, \tau_i \leq R < \sum_{j=i}^k \tau_j, \tau_k > R\right) \\ &= P(\forall_i \in \llbracket 1; k-1 \rrbracket, \tau_i \leq R, \tau_k > R) \\ &= \int_{x_1=0}^R P(\forall_i \in \llbracket 2; k-1 \rrbracket, \tau_i \leq R, \tau_k > R/\tau_1 = x_1) \\ &\dots \\ &\dots \end{aligned}$$

$$\begin{aligned}
&= \int_{x_1=0}^R \int_{x_2=R-x_1}^R \dots \int_{x_{k-1}=R-x_{k-2}}^R P(\tau_k > R/\tau_{k-1} = x_{k-1}) \times \\
&\quad \prod_{i=2}^{k-1} dP(\tau_i = x_i/\tau_{i-1} = x_{i-1}) dP(\tau_1 = x_1) \quad (5.14)
\end{aligned}$$

### 5.3.5 Problem Solution

Let  $\lambda' = \lambda R$ ,  $\rho = \lambda' e^{-\lambda'}$ , and  $\rho' = e^{-\lambda'}$ . In the special case of the inter-distance process described in 5.2.2 (i.e. equations (5.2), (5.3), (5.4), and (5.5)), the probability of the number of connected vehicles becomes with a simple change of variables as follows:

$$\begin{aligned}
P(N_b = k) &= \rho^{k-1} \times \\
&\quad \int_{u_1=0}^1 \int_{u_2=1-u_1}^1 \dots \int_{u_{k-1}=1-u_{k-2}}^1 \prod_{i=1}^{k-2} e^{-\lambda' u_i} \prod_{i=1}^{k-1} du_i \quad (5.15)
\end{aligned}$$

In order to calculate this integral, it is convenient to denote

$$\begin{aligned}
\mathfrak{M}_{\alpha,k} &= \rho^k \times \\
&\quad \int_{u_1=0}^1 \int_{u_2=1-u_1}^1 \dots \int_{u_k=1-u_{k-1}}^1 \prod_{i=1}^{k-1} e^{-\lambda' u_i} \prod_{i=1}^k du_i \quad (5.16)
\end{aligned}$$

All the probabilities  $P(N_b)$  are function of such integrals.

It can be observed that:

$$P(N_b = k) = \rho \mathfrak{M}_{1,k-2} \quad (5.17)$$

These probabilities can be calculated by recurrence. Actually, by using integration by parts:

$$\left\{ \begin{aligned} \mathfrak{M}_{0,k} &= \mathfrak{M}_{0,k-1} - \rho \mathfrak{M}_{1,k-2} \end{aligned} \right. \quad (5.18)$$

$$\left\{ \begin{aligned} \mathfrak{M}_{\alpha,k} &= \mathfrak{M}_{0,k-1} - \frac{\alpha}{\lambda'} \mathfrak{M}_{\alpha-1,k} - \frac{\rho \mathfrak{M}_{\alpha+1,k-2}}{\alpha + 1} \end{aligned} \right. \quad (5.19)$$

Now, for medium and dense networks that is  $\lambda R \geq \ln 4$ , a closed form expression can be given for the z-transform of these probabilities. Let  $Q(z)$  be the z-transform of  $N_b$  and  $M_1(z)$  the z-transform of  $\mathfrak{M}_{1,k}$ :

$$Q(z) = \sum_{k=1}^{+\infty} P(N_b = k) Z^k \quad (5.20)$$

$$M_1(z) = \sum_{k=1}^{+\infty} \mathfrak{M}_{1,k} z^k \quad (5.21)$$



**Theorem 2:**

In the special case where  $\lambda R \geq \ln 4$ , the z-transform  $M_1(z)$  given in Eq. (A.12) of (Appendix A) can be expressed in a close formula as follows:

$$M_1(z) = \frac{h_1(z) + h_2(z) + h_3(z)}{\rho z^2 \left[ 1 + \sqrt{1 - 4\rho'z^2} - 2ze^{\frac{1}{2}\lambda'(\sqrt{1 - 4\rho'z^2} - 1)} \right]} \quad (5.22)$$

where

$$h_1(z) = \sqrt{1 - 4\rho'z^2} [(1 - \rho' - \rho)z^3 - (1 - \rho')z^2 - z(1 - \rho) + 2 - \rho' - \rho] \quad (5.23)$$

$$h_2(z) = e^{\frac{1}{2}\lambda'(\sqrt{1 - 4\rho'z^2} - 1)} [2\rho z^3 + 2\rho'z^2 - z - 1 + (z - 1)\sqrt{1 - 4\rho'z^2}] \quad (5.24)$$

$$h_3(z) = z^3(\rho' + \rho - 1) + z^2(1 - 3\rho' - 2\rho) + z(1 - \rho) + \rho' + \rho \quad (5.25)$$

**Proof:** The proof in Appendix A

The moments of the number of hops can simply be obtain by differentiating  $Q(z)$ .

**Theorem 3:**

The z-transform of  $N_b$  is:

$$Q(z) = \rho'z + \rho z^2(1 + M_1(z)) \quad (5.26)$$

**Proof:**

$$\begin{aligned} P(N_b = 1) &= P(\tau_1 > R) \\ &= e^{-\lambda R} \end{aligned} \quad (5.27)$$

Moreover,

$$\begin{aligned} P(N_b = 2) &= \int_{x_1=0}^R P(\tau_2 > R/\tau_1 = x_1) dP(\tau_1 = x_1) \\ &= \lambda R e^{-\lambda R} \end{aligned} \quad (5.28)$$

Then, the average number of hops in the connected component for an infinite road length can be calculated by differentiating Eq. (5.22) with respect to z as follows:

$$\begin{aligned}
E(\text{no. of hops}) &= \sum_{k=1}^{+\infty} P(N_b = k) = \left( \frac{\partial M_1(z)}{\partial z} \right)_{z=1} \\
&= P(N_b = 1) + 2P(N_b = 2) + \rho \left( \frac{\partial M_1(z)}{\partial z} \right)_{z=1} \\
&= \rho' + 2\rho + 2\rho M_1(1) + \rho \left( \frac{\partial M_1(z)}{\partial z} \right)_{z=1}
\end{aligned} \tag{5.29}$$

The average size of the connected component can be calculated as in [72] as:

$$E(\text{size}) = \frac{1}{\lambda e^{-\lambda R}} - \frac{1}{\lambda} \tag{5.30}$$

Finally, the number of hops can be calculated in terms of the average road length as:

$$E(\text{no. of hops})_L = \frac{E(\text{no. of hops})}{E(\text{size})} \times L \tag{5.31}$$

Then, calculating the delay for transmitting a message between two nodes on a road is directly solved by multiplying Eq. (5.29) directly by the delay taken by a vehicle to transmit its message ( $T_H$ ).

### 5.3.6 V2V Multi-Segment Model

In real life, the traffic flow changes along the road due to traffic lights, traffic jams, road curves, etc. Therefore, a real V2V communication cannot be modeled using a simple linear relaying scenario.

In order to match the real scenarios in roads, I propose a new theorem: assuming each road to be divided into separate segments ( $B$ ), each having a vehicle density and different arrival rate. This theorem would adapt the obtained results to the real roads scenarios. Therefore, the total number of hops in the road will be the summation of each segment's hops as follows:

$$E(\text{no. of hops})_{Total} = \sum_{B=1}^{\infty} E(\text{no. of hops})_{L,B} \tag{5.32}$$

Accordingly, the time delay between two nodes on the road using the segmentation theorem is calculated using:

$$D_{total} = \sum_{B=1}^{\infty} \frac{E(\text{no. of hops})_B}{E(\text{size})} \times L_B \times T_H \tag{5.33}$$

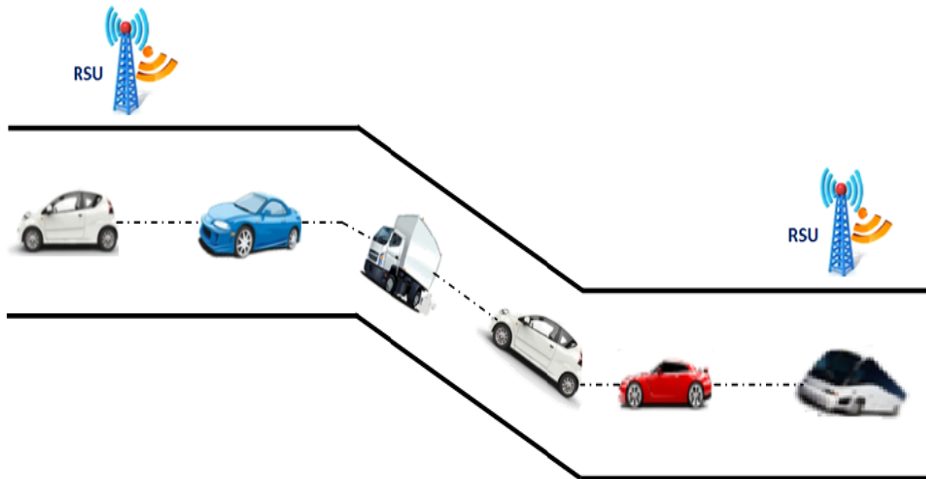
It will be showed later that the complete model with Multi-segments gives very satisfactory results compared to the simulation scenarios as will be discussed in the performance evaluation section.

## 5.4 V2V Link Model Validation

In this part, the maturity of the analytical model is tested in calculating the number of hops between two nodes on a road and hence the delay between them. The link model used is shown in Fig. 6. The analytical results are calculated using C++ and the simulation results are obtained using Matlab (2012a). The studies are decomposed into several experiments for the ease of surveying. First, the following network design assumptions as follows were made:

- It is assumed the vehicle, which detects the event is the same vehicle that transmits the alert message and that the destination node is the nearest RSU.
- The total road length between these two nodes ( $L = 2, 3, \text{ and } 4\text{Km}$ ).
- The results are obtained at different transmission ranges ( $R = 150, 200, 300, 350, 450, \text{ and } 500\text{m}$ ).
- The vehicles density range is from 0.01 to 0.1 vehicles per meter in step of 0.01 and the distribution on the road is assumed to be Poisson.
- The mobility of vehicles is neglected since nodes remain almost stationary within a message transmission time [83].
- The number of hops is obtained versus the  $\lambda/L$  (vehicles per meter) that can be calculated according to the following formula:

$$\lambda/L = \frac{\lambda(\text{no. of Vehicles})}{\text{Road Length (Meter)}} \quad (5.34)$$

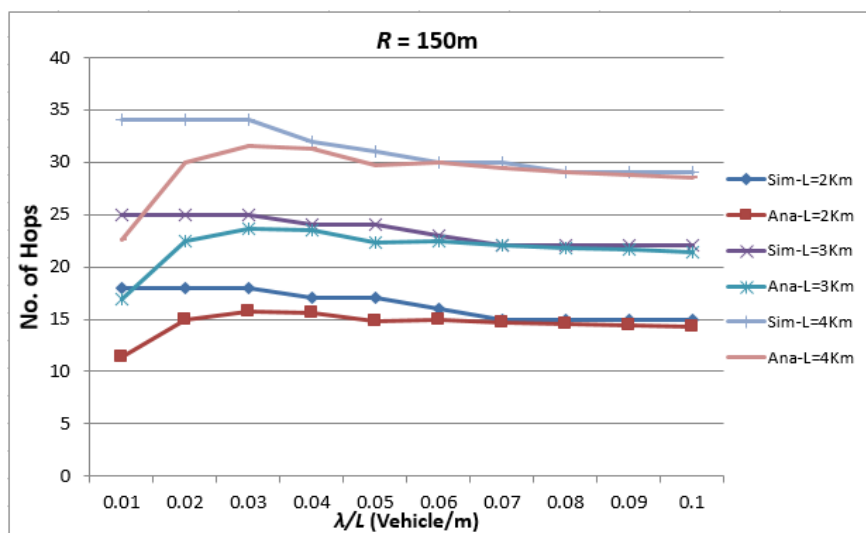


**Figure 5.2:** V2V link model

**Experiment 1:** in this experiment, the number of hops is calculated between the vehicle that detects an event and the nearest RSU versus the vehicles density ( $\lambda/L$ : vehicles/m). The transmission range is assumed to be  $R = 150, 200, 300, 350, 450, \text{ and } 500\text{m}$  and

the vehicles density varies from 0.01 to 0.1 vehicle/m in steps of 0.01. The experiment was repeated for different distances between the vehicle that detects the event and the nearest RSU, specifically:  $L = 2, 3,$  and  $4\text{Km}$  respectively. As shown in Fig. 5.3 up to Fig. 5.8, the increase of the distance between the source and destination yields to an increase of the number of hops as expected. The analytical results of the number of hops at the mentioned distances are settled with respect to the increase of the vehicle density. Obviously, from the figures, the results stability points are directly proportional with the vehicle density, which means that the number of hops tends to a fixed value as the number of vehicles on the road increases until reaching a saturation case where the increase of the number of vehicles has no effect. This is due to the model that is based on the shortest path between the source and destination and hence it is not affected by the increase of the vehicles density on the road.

As shown in these figures, the number of hops is inversely proportional to the transmission range assuming the same vehicles density. Additionally, as the transmission range increases, a minor difference appears between the analytical and the simulation results if the distance between the vehicle that detects the event and the nearest RSU is not much larger than the transmission range. It is very clear in Fig. 5.7 and Fig. 5.8, when the transmission range  $R = 450$  and  $500\text{m}$ , and the distance between the vehicle that detects the event and the nearest RSU:  $L = 2, 3,$  and  $4\text{Km}$ . This is because the distance between the two proposed nodes  $L$  is not much high than the transmission range  $R$ .



**Figure 5.3:** Comparison of number of hops of different road lengths at a transmission range ( $R = 150\text{m}$ )

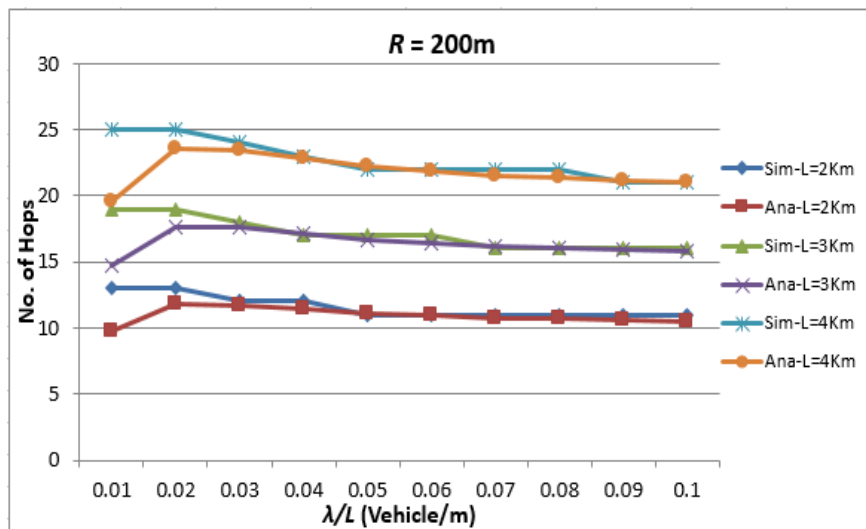


Figure 5.4: Comparison of number of hops of different road lengths at a transmission range ( $R = 200m$ )

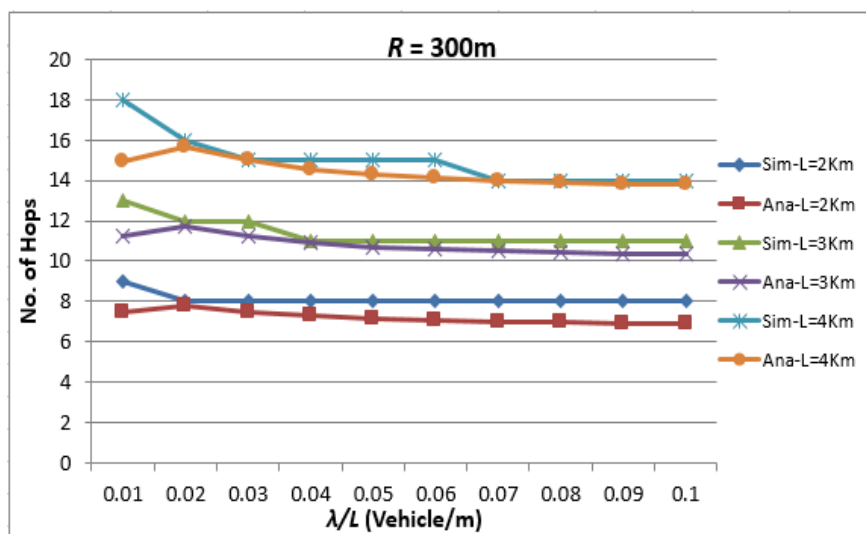
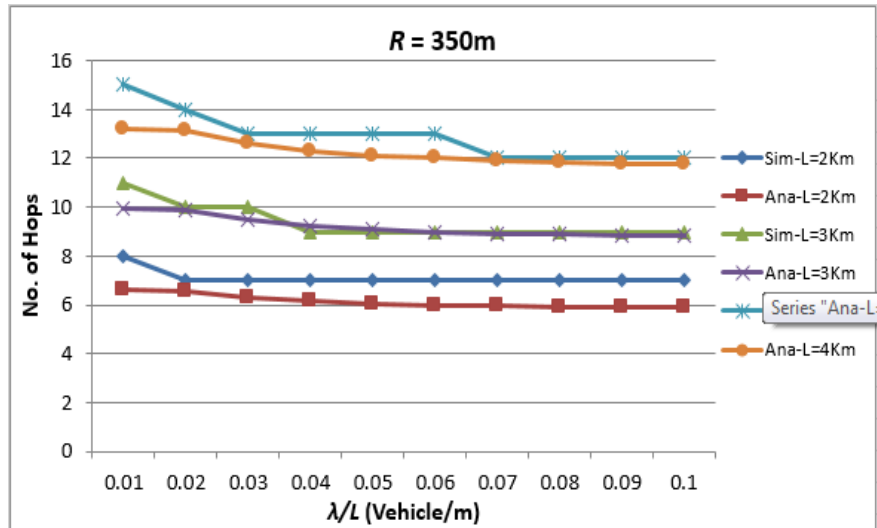
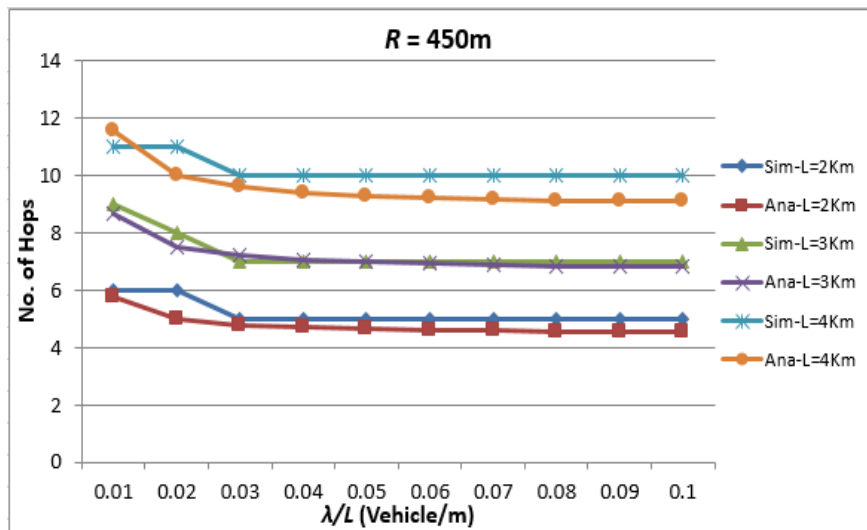


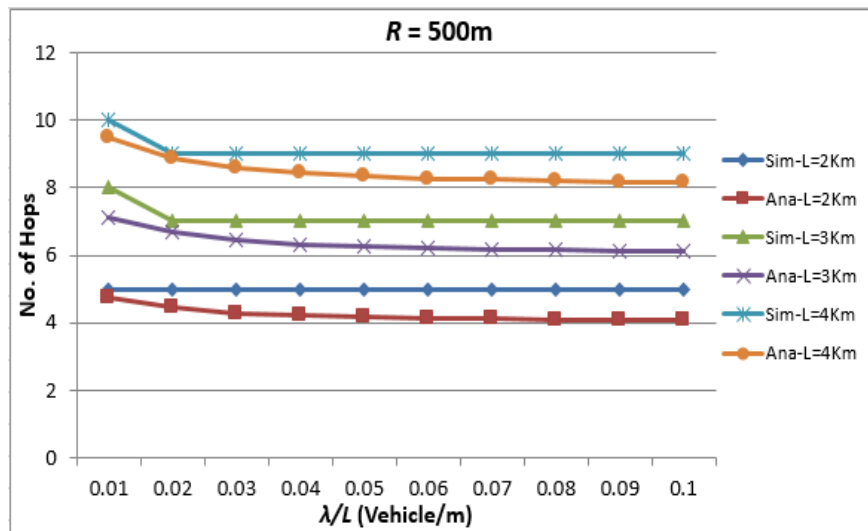
Figure 5.5: Comparison of number of hops of different road lengths at a transmission range ( $R = 300m$ )



**Figure 5.6:** Comparison of number of hops of different road lengths at a transmission range ( $R = 350\text{m}$ )

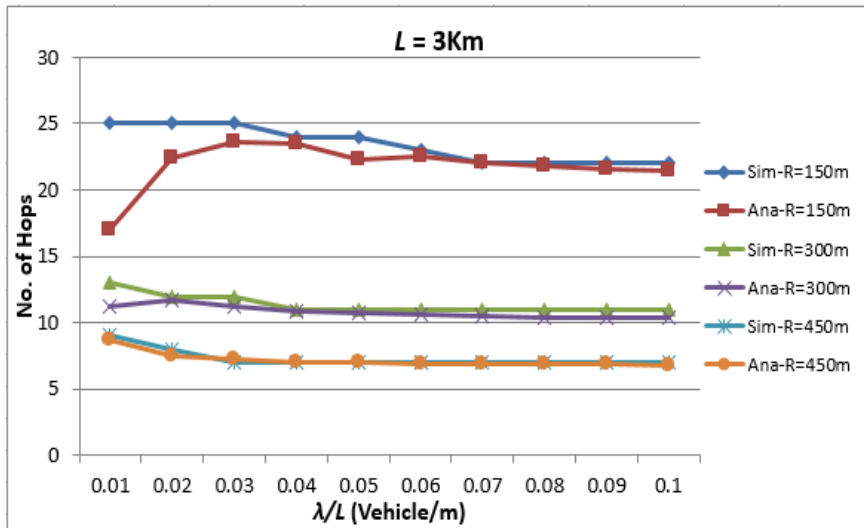


**Figure 5.7:** Comparison of number of hops of different road lengths at a transmission range ( $R = 450\text{m}$ )

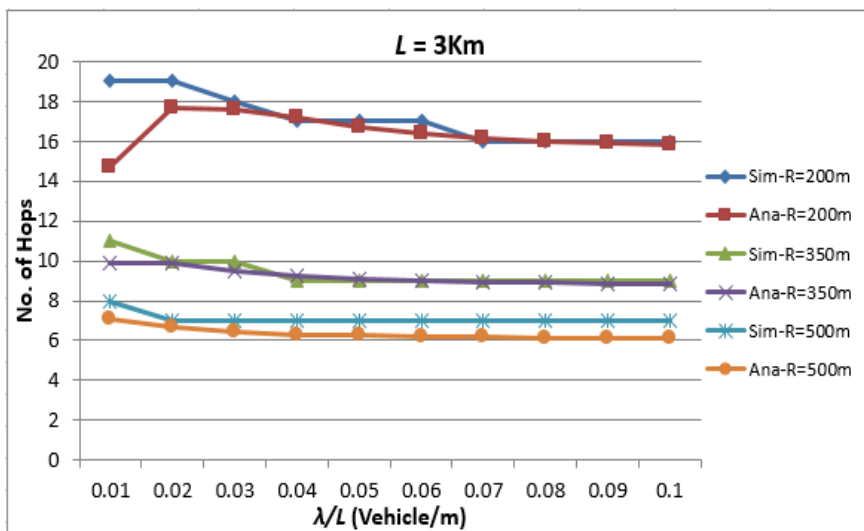


**Figure 5.8:** Comparison of number of hops of different road lengths at a transmission range ( $R = 500\text{m}$ )

**Experiment 2:** in this experiment, the effect of the transmission range  $R$  is studied on the number of hops when the distance between the vehicle that detects the event and the nearest RSU is ( $L = 3\text{Km}$ ). The experiment was repeated for transmission ranges of  $R = 200, 350,$  and  $500\text{m}$ . As the results figure will be complex if all the transmission ranges are compared together in the same figure due to the dense number of lines (12 lines), the results are divided into two figures for more clarity and ease of comparison. The figures scales are the same for more comparison accuracy. Figure 5.9 shows the number of hops for the transmission range  $R = 150, 350,$  and  $450\text{m}$ , and Fig. 5.10 shows the results for the transmission range  $R = 200, 300,$  and  $500\text{m}$ . The Figures show the results of the analytical model along with those obtained from the simulation. The Figures confirms that a saturation of the hops number is reached at high vehicles densities. On the other hand, the increase of the transmission range speeds up reaching the saturation value at lower vehicles densities for both the analytical and the simulation results.



**Figure 5.9:** Comparison of number of hops of different transmission ranges ( $R = 150$ ,  $300$ , and  $450\text{m}$ ) at distance between the event initiator vehicle and the nearest RSU ( $L = 3\text{Km}$ )



**Figure 5.10:** Comparison of number of hops of different transmission ranges ( $R = 200$ ,  $350$ , and  $500\text{m}$ ) at distance between the event initiator vehicle and the nearest RSU ( $L = 3\text{Km}$ )

**Experiment 3:** the communication delay is calculated between the vehicle that detects the event and the nearest RSU versus the vehicles density at different transmission ranges of  $R = 150$ ,  $200$ ,  $300$ ,  $350$ ,  $450$ , and  $500\text{m}$  respectively. The distance between the vehicle that detects the event and the nearest RSU is ( $L = 3\text{Km}$ ). As in the previous experiment, the results are divided into two figures for more simplicity and clarity. Since modeling the IEEE 802.11p is out of scope, the results of [83] is used to obtain



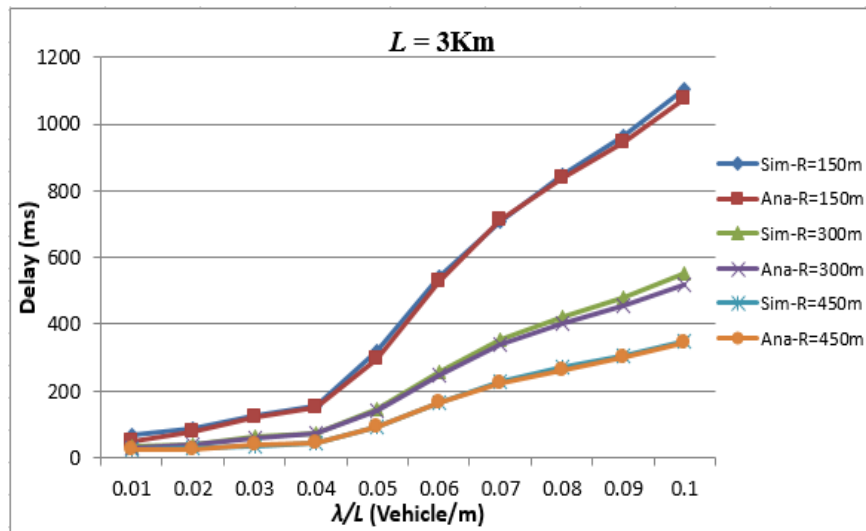
the analytical and simulation values per hop of the IEEE 802.11p broadcast performance in terms of time. The authors of this work developed a Markov chain model for the IEEE 802.11p broadcast. As mentioned in their work, there are two main types of safety messages: emergent safety messages and routine safety messages. The emergent safety messages have the highest priority that matches the proposed safety algorithm. The same model assumptions mentioned in [83] are conformed to use their delay results per hop of the analytical and simulation of the IEEE 802.11p broadcast. These results are listed in Table 5.1 showing the minimum, maximum, and the average delay for the emergent safety messages at vehicles densities of 0.01 to 0.1 in steps of 0.01. The analytical and simulation values of the communication delay per hop are almost the same at the mentioned vehicles densities.

**Table 5.1:** IEEE 802.11p Mac Access Delay

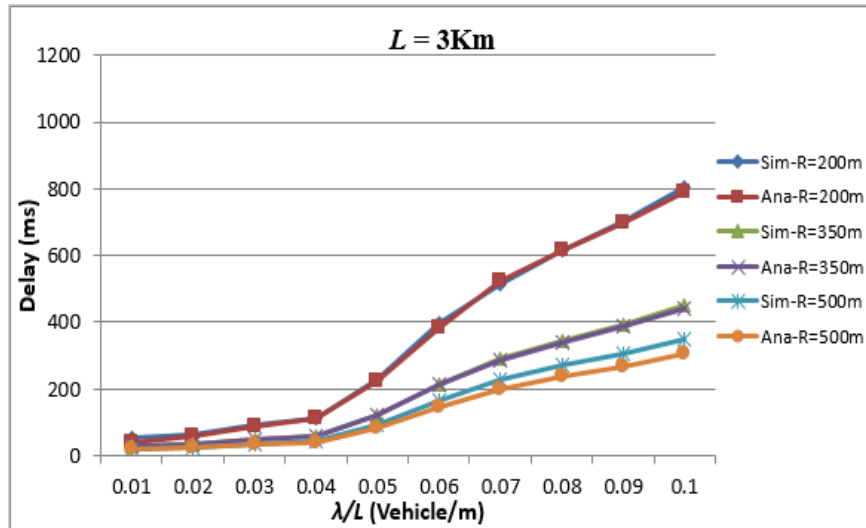
<b>Density (Vehicle/m)</b>	<b>Min Delay (ms)</b>	<b>Max Delay (ms)</b>	<b>Average Delay (ms)</b>
0.01	1.5373	3.9954	2.76635
0.02	1.5377	5.3343	3.436
0.03	1.5371	8.6794	5.10825
0.04	1.5376	11.4207	6.47915
0.05	1.5373	25.1149	13.3261
0.06	1.5371	45.4646	23.50085
0.07	1.5372	62.9478	32.2425
0.08	1.5371	75.341	38.43905
0.09	1.537	86.0945	43.81575
0.1	1.5371	98.7202	50.12865

Figure 5.11 and Fig. 5.12 show the delay comparison of different vehicle density at different transmission ranges at a distance between the event initiator vehicle and the nearest RSU is ( $L = 3\text{Km}$ ). As shown in the Figure, the delay increases with the increase of the vehicles density at each mentioned transmission range. The reason for this is that the increase of the vehicles density yields to more transmission demands and channel accessing. In conclusion, the communication delay is directly proportional to the vehicles density if the transmission range is fixed. As for the transmission range, the

number of relays between a source and a destination decreases with the increase of the transmission range since the vehicle communication coverage increases.



**Figure 5.11:** The delay comparison of different vehicle density at different transmission ranges ( $R = 150, 300,$  and  $450\text{m}$ ) at distance between the vehicle that detects the event and the nearest RSU ( $L = 3\text{Km}$ ).



**Figure 5.12:** The delay comparison of different vehicle density at different transmission ranges ( $R = 200, 350,$  and  $500\text{m}$ ) at distance between the vehicle that detects the event and the nearest RSU ( $L = 3\text{Km}$ ).

## 5.5 Conclusion

In this chapter, an analytical model to calculate the communication delay between two nodes in VANETs was proposed. This model gives very satisfactory

results compared to real vehicular communication scenarios. The model is valid to estimate an accurate value of the communication delay between two vehicles in VANETs.

In the next chapter, the architecture framework, an analytical model for the IMS servers' performance, and finally the RTT of implementing the proposed VANET application controlled by IMS are introduced.

## Chapter 6

# Modeling Interactive Real-Time Applications in VANETs with Performance Evaluation

### Contents

---

<b>6.1 Introduction.....</b>	<b>95</b>
<b>6.2 Related Work.....</b>	<b>97</b>
<b>6.3 Application Framework.....</b>	<b>98</b>
6.3.1 The Architecture Model .....	98
6.3.2 The VANET Communication Model.....	100
<b>6.4 IMS Performance Modeling.....</b>	<b>103</b>
<b>6.5 Performance Evaluation.....</b>	<b>108</b>
6.5.1 IMS Queuing Modeling Validation.....	108
6.5.2 RTT Calculations .....	110
<b>6.6 Conclusion.....</b>	<b>112</b>

---

### 6.1 Introduction

Today, there is a rapid evolution of ITS. One of its main objectives is to improve safety on the roads. VANET has been considered as an efficient and effective method to meet ITS's requirements by providing various applications, including collision warning, up-to-date traffic information, active navigation, and infotainment [84]. In VANETS, the vehicles communicate with each other via short-range wireless MAC protocols such as IEEE 802.11p [19].

The applications envisioned in VANET can be classified into safety related applications and user related applications [85]. On the other hand, smart wearable devices [86] and USNs are emerging rapidly providing many reliable services facilitating people life. Those very useful small end terminals and devices require a global communication substrate to provide a comprehensive global end user service. The ITU-T recommendations for USN present the requirements for a platform to

several services and applications [1]. Wearable devices and USNs can have a large field of applications if they are integrated with the ITS.

To the best of my knowledge, there is no complete model, which integrates these technologies: USN, VANET, and IMS. In this work, IMS is used as a service controller sub-layer in the USN environment. It provides the service requirements of USN applications and services [1]. Additionally, it allows utilizing its benefits and features [1] such as: support for heterogeneous access networks and extensive set of services. The integration between the USN controlled by IMS-based NGN and VANET provides a rich environment for various critical applications especially in health and safety on roads.

In this chapter, a detailed network architecture is developed for an end-to-end road safety service based on IMS as a service controller sub-layer to VANETs and wearable devices. The proposed architecture follows the requirements of the ITU recommendations of the USN [1]. Since safety applications are delay sensitive, the time taken by an alert to be sent until a response is received is very critical and need to be measured. This time is called the Round Trip Time (RTT). Therefore, in the thesis, an analytical solution is developed to model the functionality of the IMS servers based on the proposed application signaling flow. This model is combined with the modeling solution of the link connectivity between vehicles in roads that is introduced in chapter 5 to calculate the RTT of implementing the proposed safety application. The model is general enough to be applied for any other VANET application. This would help to guarantee the reliability of the proposed network solution specially the use of the IMS as a controller of VANETs real time applications. The analytical results derived from the two models equations are compared to simulations to prove their validity. As far as I know, it is the first contribution where such a complete approach is used to model this complex architecture. The detailed contributions of this chapter can be summarized as follows:

- Proposing a new complete model that integrates between USN, VANET, and IMS-based NGN networks to build safety applications in VANETs.
- Developing a complete signaling flow to implement the proposed safety application in the IMS using SIP.

- Developing a network queuing model for the IMS servers processing functionality to provide a full estimation of the delay as a function of the alert arrival rate to the RSU.
- Calculating the total RTT starting from transmitting an event alert message until receiving a response from the IMS network. This is to evaluate the reliability of the IMS to be used as a controller for real time applications.

## 6.2 Related Work

Most of the research in VANETs is focused on optimizing the data dissemination protocols, VANET link models, and security in VANET communications. Very few contributions look at the complete architecture including the VANET applications as it should be considered as a whole. As the thesis main concern is the network modeling and its applications, contributions in both areas are reviewed. This section presents the related work of two approaches, which this part of the thesis concentrates on to calculate the RTT of implementing VANET services controlled by the IMS. Part one describes the related work in modeling the IMS network servers. Finally, part two presents the integration of the VANET and the IMS platform.

For the IMS network modeling, the authors of [87] proposed a scheme for modeling and optimizing the IMS network design using  $M/M/1/\infty$  queuing. The authors used utility functions to optimize the service rate of the IMS servers. I believe this model did not take into consideration the capacity planning of the IMS. Moreover, its evaluation experiment is not precise as it was based on two proxy servers without taking into consideration the other IMS layers' servers.

In [88], authors proposed to model and simulate the IMS network using  $M/M/1$  network model assuming the service arrival rate is exponential. This queuing model is very theoretical and cannot simulate the real conditions of the IMS network as will be explained.

Another work proposed modeling the IMS servers using Baskett, Chandy, Muntz and Palacios (BCMP) networking [89] for an authentication method. The solution considers an open queuing network model and hence is too simple. Moreover, this work does not take into consideration the messages reply in calculating the servers delay.

Regarding the use of the IMS as the platform for implementing the VANET application, there is very little literature in that area. In [90], authors proposed an integration between the ITS and IMS. They proposed the integration based on a design for a gateway on the vehicle onboard device. The work in [91] extended the idea in [90]. It presented an IMS-based platform for the deployment of services in vehicular network. They integrated two service enablers to enrich presence and instant messaging and two customized IMS clients. They aimed to provide a service platform of a control mechanism enabling the vehicular terminals to operate these services efficiently regardless of the access technology.

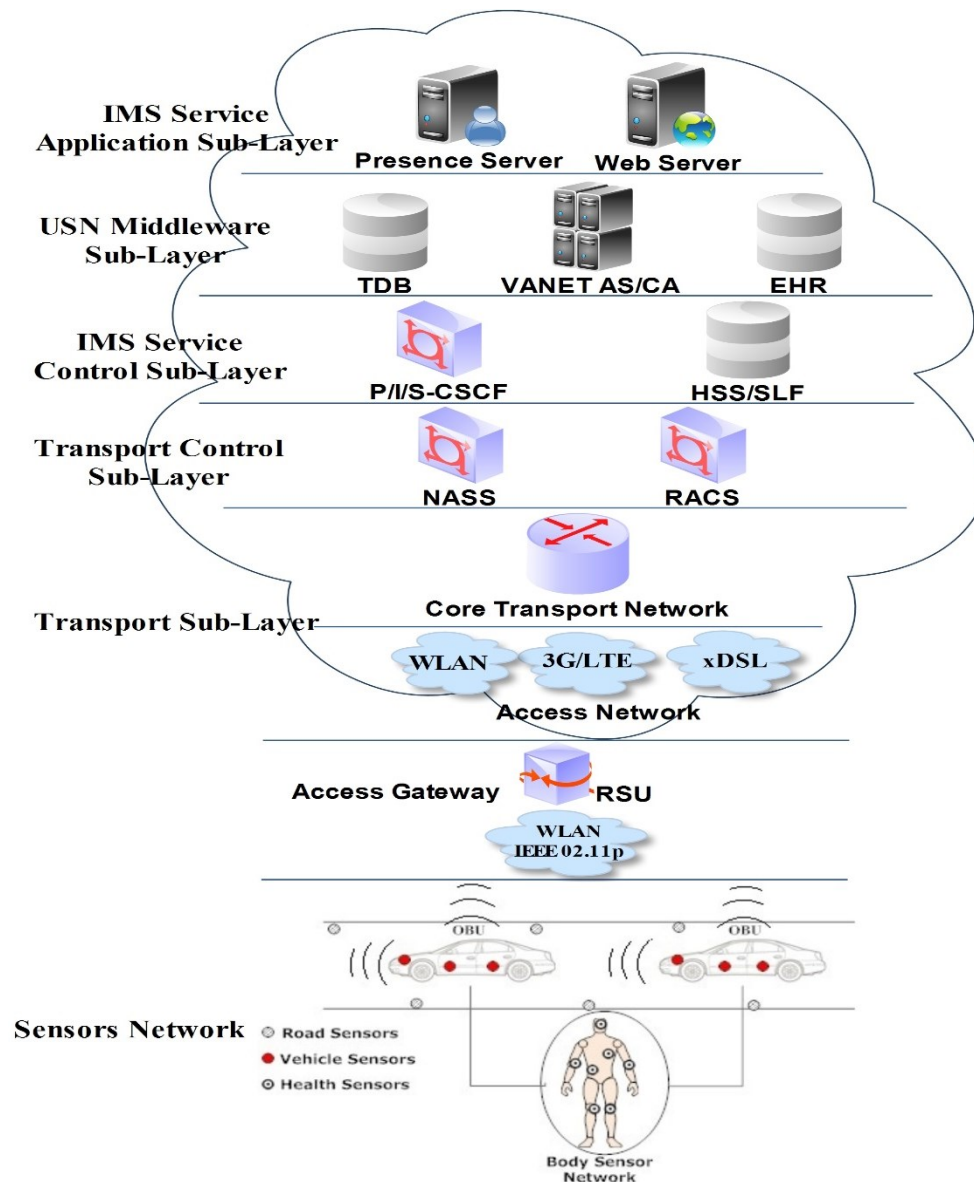
In these articles, authors did not present a detailed functional model for the proposed integration and their service enablers. Their work concentrated on developing a real service platform. However, they did not mention the parameters they used in their scenarios as well as the road traffic load and its distribution. Therefore, these results are limited in scope.

The authors of [92] proposed an integrated architecture for the VANET with the IMS in the presence of WSNs. They proposed a design for a gateway, which is the central point of the integration. The integration was proposed in terms of how to access the IMS network. All the previous work share the same problem. They focused on developing a design of the gateway required for that integration without mentioning the requirements of the integration of the middleware layer in the USN as defined in the ITU recommendations [1].

## **6.3 Application Framework**

### **6.3.1 The Architecture Model**

This subsection presents the model architecture. A complete architecture is proposed that complies with the ITU requirements [1] and follows the proposed model in in chapter 4 based on IMS as a controller for the VANET applications. The proposed architecture is divided into two stratum: transport stratum and service stratum as shown in Fig. 6.1. These stratum were described before in the proposed architecture in chapter 4. Therefore, in this section, the changes only with the architecture model of Fig. 4.1 will be described.



**Figure 6.1:** Next generation VANET network architecture

The SN contains different types of sensors with wireless capability and/or wearable devices. The basic difference in these two terms is that a wearable device is usually not capable of routing or forwarding but only reporting information to a gateway, while sensors can organize themselves in more complex connected graphs. These two kinds of nodes observe the vehicle's driver and the surrounding atmosphere as well. In addition to this, mechanical sensors fixed on the vehicle can detect failure or warnings within the car mobility. Data is then aggregated using the OBU fixed in the vehicle.

The access gateway in Fig. 6.1 contains the RSUs, which provides the accessing and connectivity requirement between the VANET and the IMS infrastructure. It



interacts with the OBUs using DSRC based on IEEE 802.11p. On the other hand, it interacts with the IMS networking using SIP.

The USN middleware sub-layer consists of a set of logical functions to support USN and VANET applications. In addition to the this sub-layer servers mentioned in chapter 4, there is a need for a Traffic Data Base server (TDB) that contains the general safety rules, weather, and roads conditions and rules, etc. The TDB server contents are updated regularly.

Other facilities and services that cover the SN management, user service profiling and personalization, open service environment, location based service support, and service privacy of the USN requirements are used but for paper clarity not included in this description.

### **6.3.2 The VANET Communication Model**

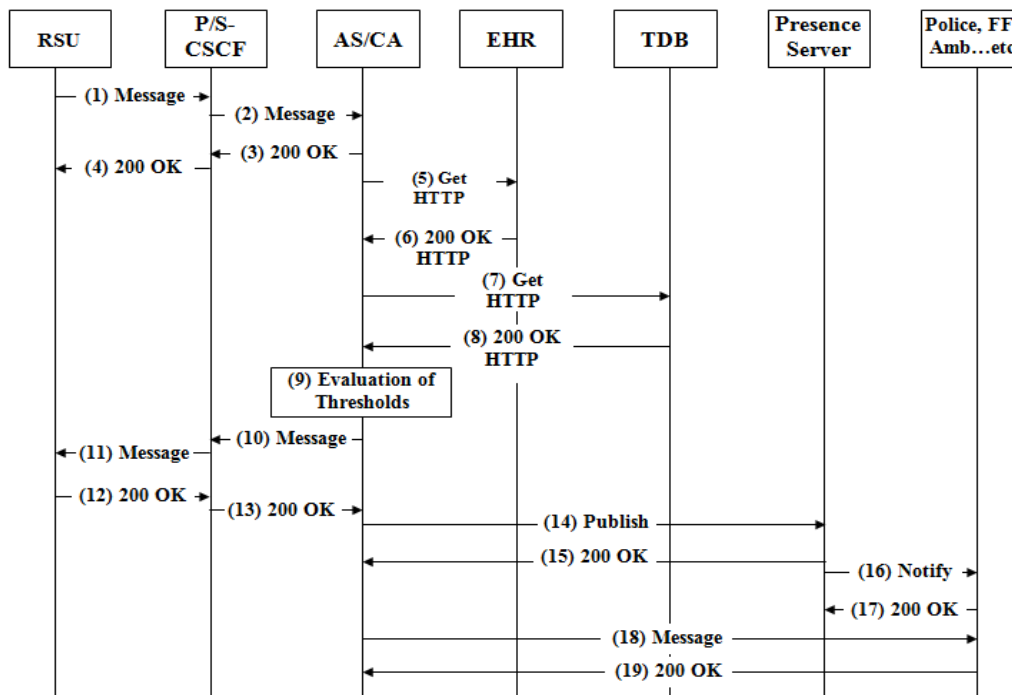
In this subsection, a new SIP signaling flow is introduced to implement the proposed safety application in VANETs.

It is considered that there are different types of vehicles on the road. These vehicles are equipped with OBUs to communicate with each other and with the RSUs. Drivers put wearable devices to monitor their vital signs and health status. The messages exchanged between vehicles or between them and the RSUs are entirely composed of elements determined by the sender, allowing flexible data exchange. There are different types of messages. The basic safety message contains vehicle safety-related information that is periodically broadcasted to surrounding vehicles. The alert messages are used for broadcasting warnings that are detected to surrounding vehicles in the vicinity. The probe vehicle data message contains status information about the vehicle to enable applications that examine traveling conditions on road segments. The traveler advisory message provides congestion, travel time, and signage information, etc.

Once a vehicle detects an event, it sends an alert message to the neighbor vehicles to be relayed to the nearest RSU. This message contains all the available data including the vehicle's ID, location, lane, speed, etc. The VANET architecture forwards the message in a V2V mode until it reaches the nearest RSU. WAVE protocol family is used for this communication. It is based on directional relaying of information. Once the RSU is reached, (signaling flow in Fig. 6.2):

- The RSU forwards the received messages from vehicles' OBUs to the P/S-CSCF of the IMS (step1). The information is formulated in the message body as in [7].
- The P/S-CSCF forwards these messages to the AS/CA (step 2).
- AS/CA will acquire the current health record of the vehicle's driver from the EHR server and/or the current road information from the TDB server using HTTP "GET" request as in steps 5 and 7 consequently.
- After that, the AS/CA performs a comparison and situation analysis to identify the status of the event occurred (step 9).
- Regarding to the result of the analysis, the AS/CA sends its decision as a SIP "MESSAGE" (step 10) to the RSU.
- The RSU relays it (step 11) to the vehicle of the event and/or its surrounding vehicles according to the instructions received from the AS/CA.
- Subsequently, the AS/CA sends "PUBLISH" request (step 14) to the PS containing the update status of the road/vehicle/drive.
- Afterword, the PS notify in step 16 the interested sites, which would be cars companies owners/cars rental shops/drivers relatives/passengers intending to travel on the road where the event occurred, etc. to know the update of their property.
- Moreover, the AS/CA sends a SIP "MESSAGE" to the interested sites including emergency sites, which would be Police/Fire Fighting (FF)/Ambulance/Web traffic server (to publish that maybe a traffic jam on that road) to handle the occurred event occurred according to their functions (step 18).

It is considered the AS/CA server already subscribed in the PS instead of the interested sites to be informed by each event in the road by a "PUBLISH" SIP message. Thus, there is no need to mention it in the signaling flow before steps 14 and 16 as it is already done when the system boots up.



**Figure 6.2:** Proposed application signaling flow

The context created for each event at the operator side would formulate the event conditions, and according to that would decide which actions should be taken to alleviate the worst cases. The feedback taken by the AS/CA could be different types of reactions or alert messages sent to the source vehicle and/or to the surrounding vehicles. The AS/CA decisions could be one or more of the following point at the same time or consequently:

- Alert to the source event vehicle's driver to stop in case there is a serious problem in the vehicle, or the driver's health status.
- Alert to the surrounded and approaching vehicles to stay away from this source event vehicle to prevent an expected accident.
- Alert to the source event vehicle to produce a noise to wakeup/alert the driver considering the vehicle is equipped by a controller for these situations.
- Within a certain period after the previous alert, a message will be sent to the vehicle to start a Car Control Mode (CCM) to take the command of it to slow down and stop behind the road.
- Send public emergency alert to the interested sites like, Police, FF, Ambulance, etc.

- Send personal emergency contacts alert to cars companies owners/cars rental shops/drivers relatives/passengers intending to take the road of the occurred event, etc.

Calculating the RTT between the event initiator vehicle and the core network is not a simple problem. It is decomposed in two parts. First, modeling the link connectivity between vehicles on roads in order to calculate the communication delay between the event initiator vehicle and the nearest RSU as described in chapter 5. Second, model the IMS servers' functions for implementing the proposed service to calculate the delay needed for that. Next section is dedicated introduce the developed analytical solution used to model the IMS servers functions to calculate the implementation delay due to the use of the IMS as a controller for real time applications in VANETs.

## 6.4 IMS Performance Modeling

This section presents the modeling the functions of the core network servers (IMS servers) to calculate the time taken to implement the proposed safety service according to the proposed signaling flow in Fig. 6.2. For this goal, the BCMP network queuing technique is used. It is helpful for modeling protocol interactions and servers behavior.

The queuing network consists of service centers/stations. Each of them has a scheduling discipline. This scheduling could be one of four service disciplines: First Come First Served (FCFS), Last Come First Served (LCFS), processor sharing, and infinite servers. Each class of customers may have a distinct service time distribution and the customers' messages are of different classes ( $q$ ).

The BCMP queues network could be open, closed, or mixed for each type of the mentioned scheduling disciplines. In this model, a mixed queuing network is used, which consists of  $N$  ( $N \geq 1$ ) service centers/stations. The model can give a good approximation of complex protocol interactions, which is considered as a compromise between complicated solutions and precision.

Figure 6.3 shows a queuing representation model of the IMS and middleware servers according to the proposed signaling flow in Fig. 6.2. There are six servers/stations (P/S-CSCF, AS/CA, EHR, TDB, PS, and interested sites).

The system state is defined as the number of each class of customers in each service center. The state  $S$  of the system is given by  $(s_1, s_2, \dots, s_N)$  where  $s_i = (n_{i1}, n_{i2}, \dots, n_{iq})$  denotes the state of each service center  $i$  and  $n_{iq}$  is the number of customers of class  $q$  in service center  $i$ . From the BCMP theorem [93], the probability distribution state in a BCMP network has the following form:

$$p(S) = cd(S)g_1(y_1)g_2(y_2) \dots g_i(y_i) \quad (6.1)$$

Where  $c$  is a normalizing constant chosen to make the equilibrium state probabilities sum to 1,  $d(S)$  is a function of the number of customers in the system, and each  $g_i$  is a function that depends on the type of service center  $i$ . This section presents the modeling the functions of the core network servers (IMS servers) to calculate the time taken to implement the proposed safety service according to the proposed signaling flow in Fig. 6.2. For this goal, the BCMP network queuing technique is used. It is helpful for modeling protocol interactions and servers behavior.

The queuing network consists of service centers/stations. Each of them has a scheduling discipline. This scheduling could be one of four service disciplines: First Come First Served (FCFS), Last Come First Served (LCFS), processor sharing, and infinite servers. Each class of customers may have a distinct service time distribution and the customers' messages are of different classes ( $q$ ).

The BCMP queues network could be open, closed, or mixed for each type of the mentioned scheduling disciplines. In this model, a mixed queuing network is used, which consists of  $N$  ( $N \geq 1$ ) service centers/stations. The model can give a good approximation of complex protocol interactions, which is considered as a compromise between complicated solutions and precision.

Figure 6.3 shows a queuing representation model of the IMS and middleware servers according to the proposed signaling flow in Fig. 6.2. There are six servers/stations (P/S-CSCF, AS/CA, EHR, TDB, PS, and interested sites).

The system state is defined as the number of each class of customers in each service center. The state  $S$  of the system is given by  $(s_1, s_2, \dots, s_N)$  where  $s_i = (n_{i1}, n_{i2}, \dots, n_{iq})$  denotes the state of each service center  $i$  and  $n_{iq}$  is the number of customers of class  $q$  in service center  $i$ . From the BCMP theorem [93], the probability distribution state in a BCMP network has the following form:

$$p(S) = cd(S)g_1(y_1)g_2(y_2) \dots g_i(y_i) \quad (6.1)$$

Where  $c$  is a normalizing constant chosen to make the equilibrium state probabilities sum to 1,  $d(S)$  is a function of the number of customers in the system, and each  $g_i$  is a function that depends on the type of service center  $i$ .

$$g(y_i) = \begin{cases} \frac{n_i!}{\mu_i^{n_i}} \left[ \prod_{q=1}^Q \frac{\lambda_{i,q}^{n_{i,q}}}{n_{i,q}!} \right] & \text{Service Centers of Type 1} \\ n_i! \prod_{q=1}^Q \frac{\lambda_{i,q}^{n_{i,q}}}{\mu_{i,q}^{n_{i,q}} n_{i,q}!} & \text{Service Centers of Types 2 \& 4} \\ \prod_{q=1}^Q \frac{\lambda_{i,q}^{n_{i,q}}}{\mu_{i,q}^{n_{i,q}} n_{i,q}!} & \text{Service Centers of Type 3} \end{cases} \quad (6.2)$$

Where  $n_i$  is the number of messages at server  $i$ ,  $\mu_{i,q}$  is the service rate at server  $i$  of the message class  $q$ , and  $\lambda_{i,q}$  is the arrival rate at server  $i$  of the message class  $q$ .

The servers of the model are assumed to be of the processor shared type and the distribution of the arrival rate of messages is Poisson. There are nineteen messages in the signaling flow, and they are supposed to be of the same class for simplicity (i.e.  $\lambda_i = \lambda_{i,q}$ ). According to that, Eq. (1) can be simplified as in [93] to:

$$p_i(n_i) = (1 - \rho_i) \rho_i^{n_i} \quad (6.3)$$

$$\text{Where } \rho_i = \sum \frac{\lambda_i}{\mu_i} \quad (6.4)$$

For a stable system this condition ( $\lambda_i < \mu_i$ ) must be conformed for each server  $i$ . In addition, the transmission probability ( $p = 0$ ) of each message, and the packet loss probability is small, therefore it can be ignored. Then, from Fig. 6.3, the utilization of each server can be calculated as follows:

$$\rho_{CSCF} = \lambda_{CSCF} \left( \frac{1}{\mu_2} + \frac{1}{\mu_4} + \frac{1}{\mu_{11}} + \frac{1}{\mu_{13}} \right) \quad (6.5)$$

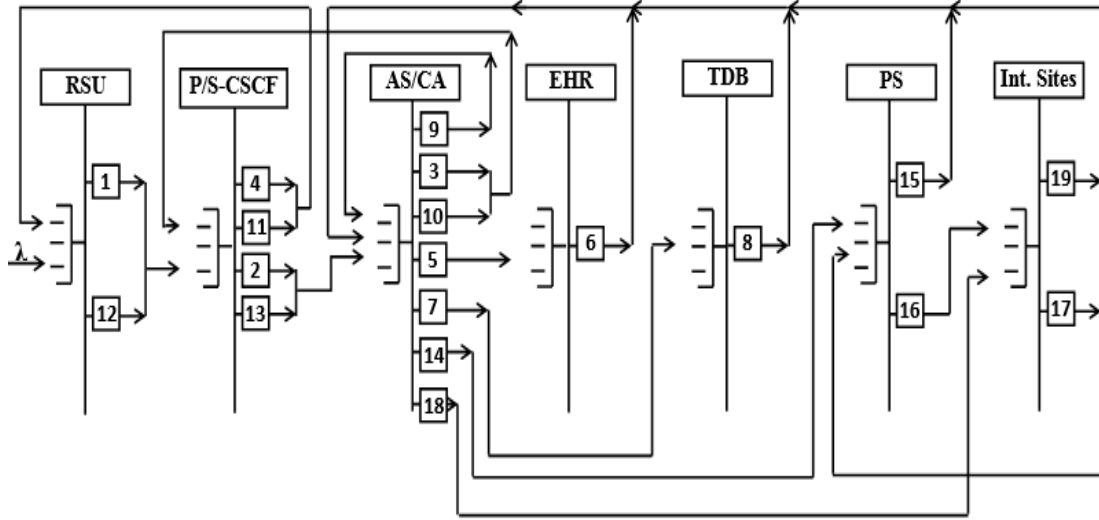
$$\rho_{AS/CA} = \lambda_{AS/CA} \left( \frac{1}{\mu_3} + \frac{1}{\mu_5} + \frac{1}{\mu_7} + \frac{1}{\mu_9} + \frac{1}{\mu_{10}} + \frac{1}{\mu_{14}} + \frac{1}{\mu_{18}} \right) \quad (6.6)$$

$$\rho_{EHR} = \frac{\lambda_{EHR}}{\mu_6} \quad (6.7)$$

$$\rho_{TDB} = \frac{\lambda_{TDB}}{\mu_8} \quad (6.8)$$

$$\rho_{PS} = \lambda_{PS} \left( \frac{1}{\mu_{15}} + \frac{1}{\mu_{16}} \right) \quad (6.9)$$

$$\rho_{Contacts} = \lambda_{interested\ sites} \left( \frac{1}{\mu_{17}} + \frac{1}{\mu_{19}} \right) \quad (6.10)$$



**Figure 6.3:** Queuing model for the proposed architecture

Assuming the system is stable, the average arrival rate of messages  $\lambda_i$  for each server  $i$  is different and is calculated according to the messages flow in each server queue, which is decomposed into two parts:

- Messages coming from outside with the arrival rate  $\lambda p_{0i}$ , where  $p_{0i}$  is the probability that a client message arrives the system at server  $i$ .
- Messages from server  $j$  with the arrival rate  $\lambda_j p_{ji}$  for all servers  $j = 1, 2, \dots, M$ . where  $p_{ji}$  is the probability that a customer completes his service at server  $i$  and goes to server  $j$ .

So, the average arrival rate for each server  $i$  can be calculated as:

$$\lambda_i = \lambda p_{0i} + \sum_{j=1}^M \lambda_j p_{ji} \quad (6.11)$$

where  $\lambda_i = e_i \lambda$ , and  $e_i$  is the rate of visiting server  $i$  to the average number of passages of that server. So, Eq. (6.11) can be written as follows:

$$e_i = p_{0i} + \sum_{j=1}^M e_j p_{ji} \quad (6.12)$$

Now, a system of equations can be deduced that satisfies the visit rate for each server  $i$ . As shown, the model considers the averages of messages types in the different servers. It does not respect the time sequence of each procedure. It is however very sufficient and does not affect the evaluation of the overall performance.

Based on the last equation and according to Fig. 6.4, the distributions of messages for each server (P/S-CSCF, AS/CA, EHR, TDB, PS, and interested sites) can be represented by the following equations:

$$e_1 = 1 + \frac{2}{7}e_2 \quad (6.13)$$

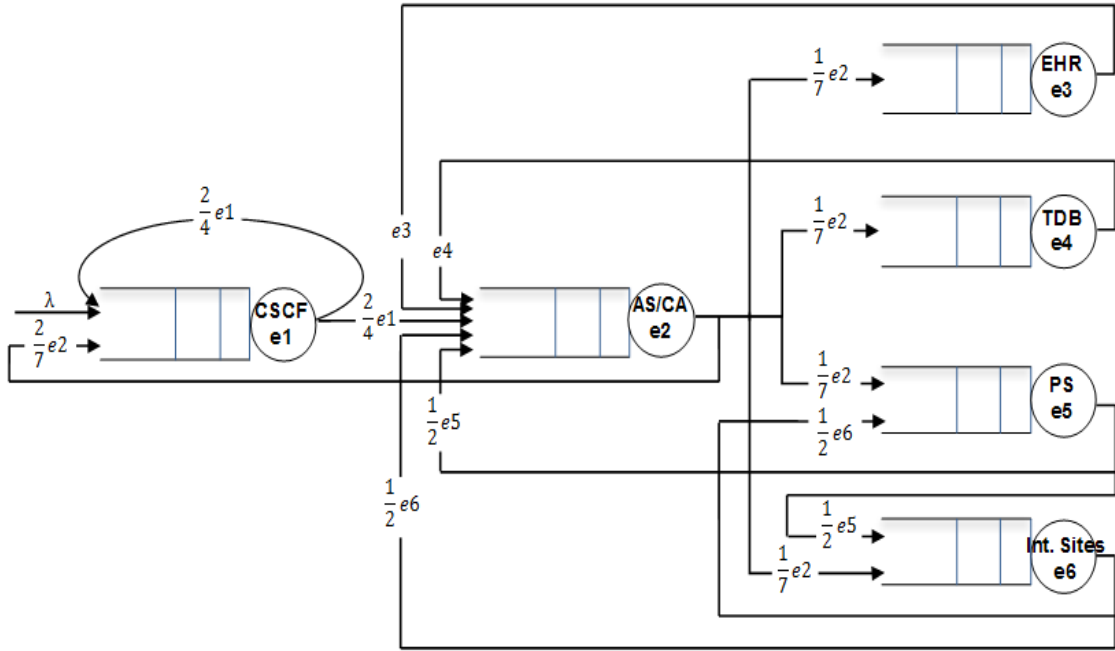
$$e_2 = \frac{2}{4}e_1 + e_3 + e_4 + \frac{1}{2}e_5 + \frac{1}{2}e_6 + \frac{1}{7}e_2 \quad (6.14)$$

$$e_3 = \frac{1}{7}e_2 \quad (6.15)$$

$$e_4 = \frac{1}{7}e_2 \quad (6.16)$$

$$e_5 = \frac{1}{7}e_2 + \frac{1}{2}e_6 \quad (6.17)$$

$$e_6 = \frac{1}{7}e_2 + \frac{1}{2}e_5 \quad (6.18)$$



**Figure 6.4:** Calculations of arrival rate for each server

Solving the above equations produces the arrival rate for each server in terms of the arrival rate of the AS/CA as it has the highest arrival rate ( $\lambda_{AS/CA}$ ) as follows:

$$\lambda_{CSCF} = \frac{4}{7}\lambda_{AS/CA} \quad (6.19)$$

$$\lambda_{EHR} = \lambda_{TDB} = \frac{1}{7}\lambda_{AS/CA} \quad (6.20)$$

$$\lambda_{PS} = \lambda_{interested\ sites} = \frac{2}{7}\lambda_{AS/CA} \quad (6.21)$$

From Eq. (6.3), the mean queue size corresponding to the average number of clients waiting on servers is calculated as:

$$E(n_i) = \sum_{n_i=1}^{\infty} n_i p_i(n_i) = \frac{\rho_i}{1-\rho_i} \quad (6.22)$$



where  $i$  stands for the servers/stations (P/S-CSCF, AS/CA, EHR, TDB, PS, and interested sites).

Using the Little's Law, the service processing time at each server  $i$  is as follows:

$$T_i = \frac{E(n_i)}{\lambda_i} = \frac{1}{(1-\rho_i)\mu_i} = \frac{1}{\mu_i - \lambda_i} \quad (6.23)$$

In order to calculate the total processing time  $D$  of the service implementation in the IMS network, the following values are summed which are:

- The time spent by the client ( $T_C$ ) to produce its messages (1, and 12 in Fig. 5.2)
- Service processing time at each server (P/S-CSCF, AS/CA, EHR, TDB, PS, and Contacts)
- Waiting time at each server's queue.

Each message transmission time( $T_t$ ).

$$D = T_C + T_t + \sum_i \frac{1}{\mu_i - \lambda_i} \quad (6.24)$$

$$T_C = \sum_{q \in Q_{RSU}} \frac{1}{\mu_q} \quad (6.25)$$

Where  $Q_{RSU} =$  (message 1, and message 12).

$$T_C = \frac{1}{\mu_1} + \frac{1}{\mu_{12}} \quad (6.26)$$

Assuming there is no queuing in the RSU, its waiting time is approximated to zero, then the final form of Eq. (6.24) is:

$$D = \frac{1}{\mu_1} + \frac{1}{\mu_{12}} + T_{CSCF} + T_{AS/CA} + T_{EHR} + T_{TDB} + T_{PS} + T_{Interested Sites} + T_t \quad (6.27)$$

## 6.5 Performance Evaluation

In this section, the proposed analytical models of the V2V link connectivity and the IMS queuing model are validated. This section is divided into two parts. In part one, the average delay of implementing the VANET application in IMS network is calculated. In part two, the average RTT of the proposed application is calculated starting from the initiator node (source vehicle) sending a message until receiving a response from the core network.

### 6.5.1 IMS Queuing Modeling Validation

In this section, the IMS analytical model is validated by comparing its performance with the simulation results. The time needed to implement the VANET

application is calculated according to the signaling flow of Fig. 6.2. The signaling flow starts when the RSU forwards the received alert message to the CSCF servers. Matlab (2012a) is used to implement the analytical model and OPNET Modeler (V.14.0) to simulate the IMS servers' functionalities. The values of the IMS servers processing time mentioned in [68] are used as in Table 6.1.

Figure 6.5 shows the processing time of the proposed VANET application using the IMS as a sub-layer controller versus the messages arrival rate at the servers for the analytical model. As expected, the time required to implement this application increases with the increase of the messages arrival rate.

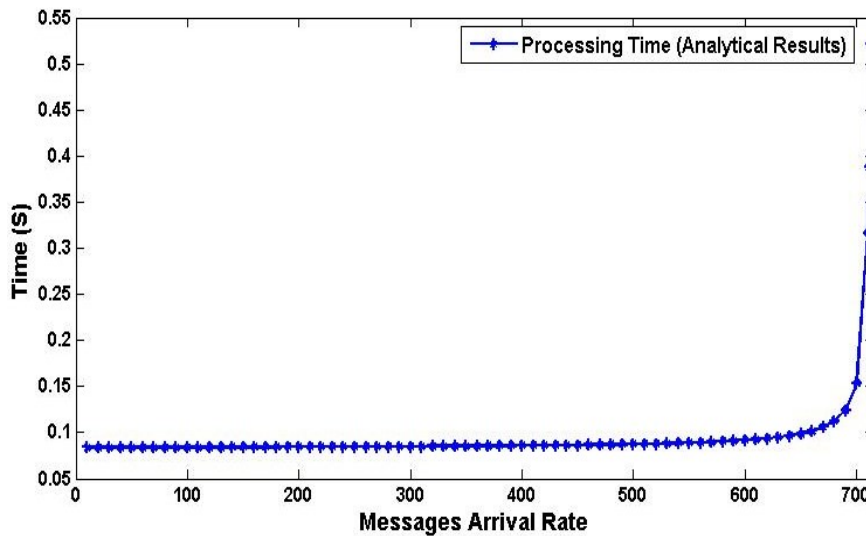
**Table 6.1:** IMS Servers Parameters Used

Parameters		Duration
Process time (microsecond)	UE	200
	P/S/I-CSCF	200
	HSS	10
Propagation delay (microsecond)	UE/P-CSCF	5,000
	other links	200

The OPNET simulator gives its results according to these parameters: processing time, transmission time, number of users, and background utilization. The same processing and transmissions times are used for the simulation and the analytical model to match the results of both. However, in OPNET there is no facility to match between the number of users/server utilization parameters and the arrival rate of messages as in the mathematical model. Therefore, the average processing time of the mathematical model is compared with the average processing time of the OPNET as in Table 6.2.

**Table 6.2:** Average Processing Time of VANET Application in the IMS Network

Analytical Versus Simulation	
MATLAB	112.3 (mS)
OPNET	124.2 (mS)



**Figure 6.5:** The processing time of VANET applications on the IMS servers

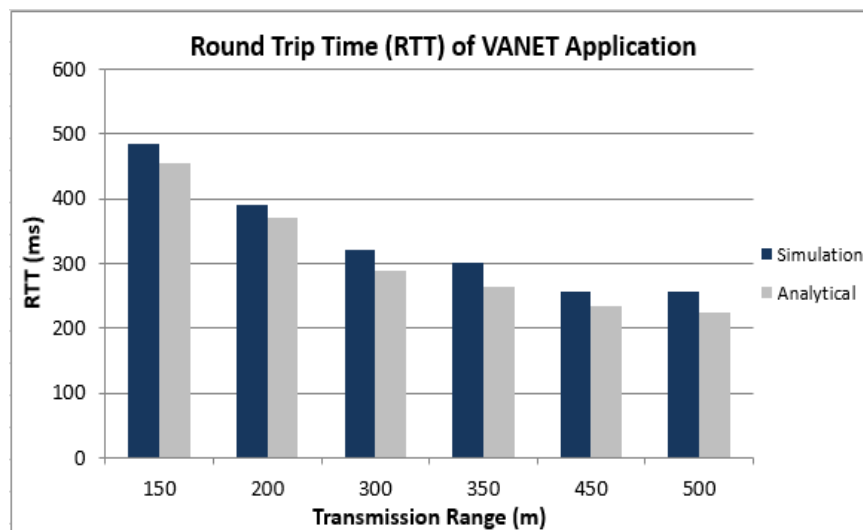
### 6.5.2 RTT Calculations

In this last part, the RTT is calculated, which is the time taken by a VANET application starting from the vehicle that detects the event sends a message until it receives a response from the core network. In order to obtain this total time, the averages of the following timers are summed:

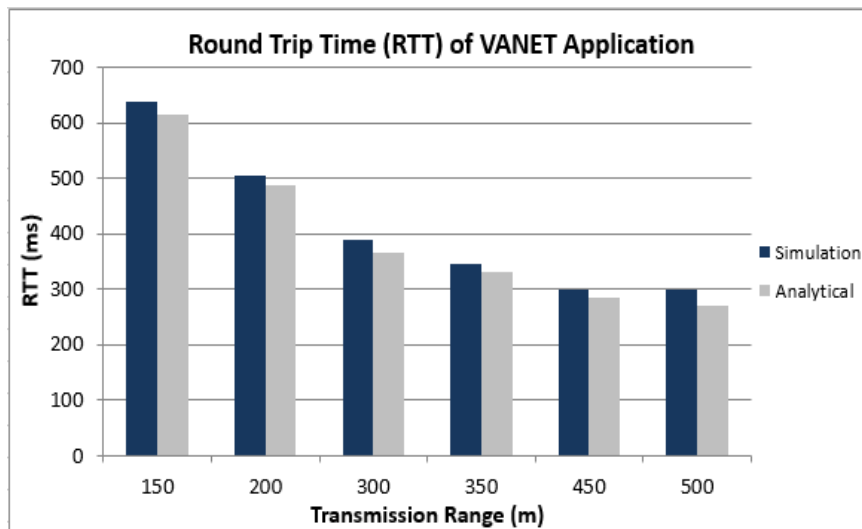
- Time required to send an alert message from the vehicle that detects the event until reaching the nearest RSU.
- Time necessary to execute the proposed application in the IMS servers according to the messages signaling flow of Fig. 6.2.
- Time needed to send the IMS feedback message to the interested sites, and to broadcast it to the vehicles in the event vicinity.

Following the proposed VANET model, the average time (analytically and by simulation) taken by the alert message to be sent is calculated between the two proposed nodes of distance  $L = 2, 3,$  and  $4\text{Km}$ . For the IMS network, the average processing time of the proposed VANET application is calculated as in Table 6.2. Finally, as the RSU is the responsible of broadcasting the feedbacks of the core network, the average time required to broadcast the feedback of the IMS is considered. Figures 6.6, 6.7, and 6.8 correspond to the mentioned inter-distance between the event initiator vehicle and the nearest RSU respectively. Figures show the analytical and simulation results are so closed. It is obvious from the RTT results that the major factor of the delay is due to the

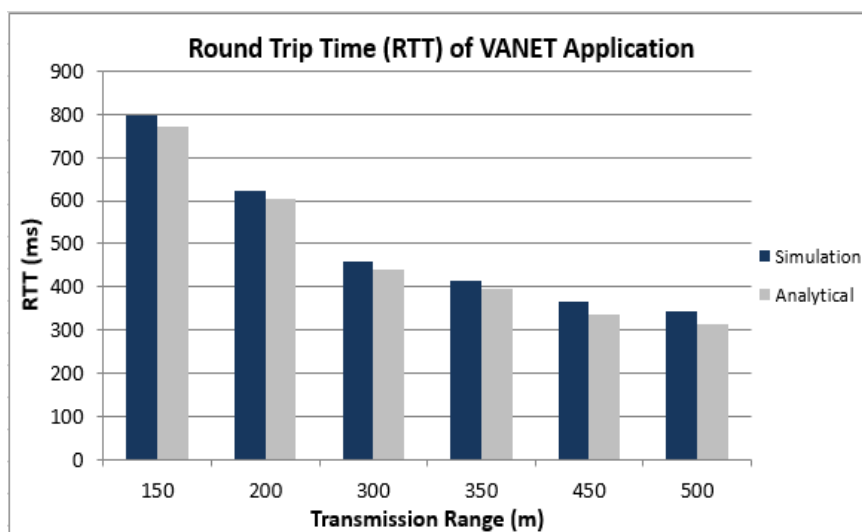
VANET specially when using a low transmission range. As cleared from the figure, the RTT is inversely proportional to the transmission range as it decreases with the increase of the transmission range. This is due to that, the number of hops between any two nodes decreases when the communication range increases and hence the processing time decreases. The IMS delay has a less effect on the RTT while the vehicular communication delay is the influential. The VANET network has the major factor in RTT calculations as the communication delay between vehicles suffers of three main reasons; vehicles density, collisions, and connection intermittent, which yields to a higher delay than in the IMS network. For example, for the case of mean inter-distance ( $L = 3\text{km}$ ), the average IMS delay is less than the VANET delay by 3.06 times if the transmission range is 200m, and it is 1.41 times less if the transmission range is 500m. Consequently, the IMS can be used in real time applications without affecting the system stability. This is because the average delay introduced by the application processing time in the IMS has a less effect on the VANET application RTT than the delay due to the VANET communication.



**Figure 6.6:** Round Trip Time comparison between the analytical and simulation results of the proposed VANET application at ( $L = 2\text{km}$ )



**Figure 6.7:** Round Trip Time comparison between the analytical and simulation results of the proposed VANET application at ( $L = 3\text{km}$ )



**Figure 6.8:** Round Trip Time comparison between the analytical and simulation results of the proposed VANET application at ( $L = 4\text{km}$ )

## 6.6 Conclusion

In this chapter, a complete model for integrating USN, VANET, and IMS is introduced. The proposal includes the signaling flow, which uses the IMS as a service controller sub-layer for these applications due to its benefits and features. Additionally, the use of IMS will fulfil the ITU service requirements of USN applications and services.

As safety applications are time sensitive, there is a need to test the validity of the proposed model. Two analytical models were developed for the proposed

architecture. First, the vehicles link connectivity on roads modeled to estimate the reporting delay of events until reaching the closest RSU using the connectivity queuing model  $GIX/D/\infty$ . The analytical model validity was proved in the performance section. It achieved a perfect performance when comparing its results with those obtained from the simulation. Second, the behavior of the IMS servers was modeled using BCMP queuing networking. The performance of the developed model is validated and it showed to be more accurate when compared to the simulation results. These models are general enough to be applied to any VANET application.

Finally, the RTT is calculated to test the reliability of the proposed application model. As a conclusion from the results, the average RTT of the proposed model is less than one second, which proves the applicability of using the IMS as a sub-layer controller for VANET applications.

The next chapter presents the conclusion of thesis work and a discussion of open issues and future work.

## Chapter 7

### Conclusions & Future Work

#### 7.1 Thesis Conclusion

Information is valuable because it can affect behavior, a decision, or an outcome. Ubiquity and awareness constitute the information-based of the future applications. These applications based on an intelligent information infrastructure of SNs connected to the existing network infrastructure that act as the backbone in supporting several fields of human life. This information infrastructure is the USN that opens wide possibilities for applications and services based on SNs to various customers such as human consumers, public organizations, enterprises and government. In addition, the network infrastructure is supposed to be the NGN.

Due to the growth development of the SNs, and its nature behavior of providing rich information, it is proposed to exploit this data mine for building new applications in health field, as it is important for humans.

In this work, the thesis contributions concentrate on three major parts, which constitute together a complete architecture solution that provide e-Health for patients and safety on roads. The integration between USN, VANET, and IMS (bottom up) are proposed.

The main contributions of this study can be summarized as follows:

1. Proposing a new data aggregation algorithm, which combines cluster and chain approaches that alleviates building routing tables.
2. Decreasing number of messages delivered from the WSNs to decrease the processing load on the core network.
3. Optimizing the power utilization for WSNs and hence extending its lifetime.
4. Relying on the use of IMS for easier integration with the existing networks such as Internet.

5. Exploiting the IMS as a unified service controller sub-layer, which paves the road for building different services based on the data provided from USN such as e-Health and safety applications.
6. Using SIP as the signaling protocol of implementing the proposed e-Health and safety applications in VANETs for its facilities.

## **7.2 Future Work**

The following are foreseen areas for further studies:

1. Building NGN testbed for implementing the proposed applications following the presented architecture is one important goal. This testbed will focus on the development of the AS/WS, HER, and TDB.
2. Implementing various types of services on WSNs such as in agriculture and weather fields. Also, developing many ITS applications.
3. Implementing the proposed data aggregation algorithm (DAP) for studying its limitations and integrity.
4. Applying DAP on VANETs to collect the sensors data messages located in the vehicle's zone.



## References

- [1] *Requirements for support of ubiquitous sensor network (USN) applications and services in the NGN environment*, ITU-T Recommendation Y.2221, 2010.
- [2] J. M. Kaplan *et al.*, “Meeting the demand for data storage,” *The McKinsey Quarterly*, June 2008.
- [3] X. Costa-Pérez *et al.*, “Latest Trends in Telecommunication Standards,” *ACM SIGCOMM Computer Communication Review*, vol.34, no.2, April 2013, pp. 64-71.
- [4] *General principles and general reference model for Next Generation Networks*, ITU-T Recommendation Y.2011, Oct 2004.
- [5] *General overview of NGN*, ITU-T Recommendation Y.2001, Dec 2004.
- [6] *IMS for Next Generation Network*, ITU-T Recommendation Y.2021, Sep 2006.
- [7] ITU-T Technology Watch Briefing Report Series, “Ubiquitous Sensor Network (USN)”, no. 4, Feb 2004.
- [8] J. Yick *et al.*, “Wireless sensor network survey,” *The International Journal of Computer and Telecommunications Networking*, vol. 52, no. 12, doi: 10.1016/j.comnet.2008.04.002, Aug 2008, pp. 2292-2330.
- [9] I.F. Akyildiz *et al.*, “A survey on sensor networks,” *IEEE Communications Magazine*, vol. 40, no. 8, doi: 10.1109/MCOM.2002.1024422, Aug 2002, pp. 102-114.
- [10] *IEEE Standard for Local and metropolitan area networks, Part 15.4: Low-Rate Wireless Personal Area Networks (LR-WPANs)*, IEEE Std 802.15.4, Sep 2011.
- [11] *IEEE Standard for Information technology-Telecommunications and information exchange between systems-Local and metropolitan area networks-Specific requirements, Part 15.3: Wireless Medium Access Control (MAC) and Physical Layer (PHY) Specifications for High Rate Wireless Personal Area Networks (WPANs)*, IEEE Std 802.15.3, Sep 2003.
- [12] R. C. Braley *et al.*, “Wireless Personal Area Networks: An Overview of the IEEE P802.15 Working Group,” *Mobile Computing and Communication Review*, vol. 4, no. 1, pp. 20-27.
- [13] *IEEE Standard for Information technology-Telecommunications and information exchange between systems-Local and metropolitan area networks-Specific requirements, Part 15.1: Wireless medium access control (MAC) and physical*

- layer (PHY) specifications for wireless personal area networks (WPANs)*, IEEE Std 802.15.1, 2005.
- [14] I. F. Akyildiz and M. Can Vuran, “Wireless Sensor Networks”, Wiley, 2010.
- [15] I. Mahgoub, M. Ilyas, “Sensor Network Protocols,” CRC Press, 2006.
- [16] C. Wang and K. Sohraby, “A survey of transport protocols for wireless sensor networks,” *IEEE Network Magazine*, vol. 20, no. 3, doi: 10.1109/MNET.2006.1637930, May-June 2006, pp. 34-40.
- [17] F. Ye, H. Luo *et al.*, “A Two Tier Data Dissemination Model for Large-scale Wireless Sensor Networks,” *8<sup>th</sup> annual international conference on Mobile computing and networking (MOBICOM’02)*, doi: 10.1145/570645.570664, Sep 2002, NY, pp. 148-159.
- [18] Dedicated Short Range Communications (DSRC), last seen August 2014, URL: <http://www.its.dot.gov/DSRC>
- [19] *IEEE Standard for Information technology--Telecommunications and information exchange between systems--Local and metropolitan area networks--Specific requirements Part 11: Wireless LAN Medium Access Control (MAC) and Physical Layer (PHY) Specifications Amendment 6: Wireless Access in Vehicular Environments*, IEEE 802.11p, July 2010.
- [20] B.K. Chaurasia *et al.*, “Suitability of MANET Routing Protocols for Vehicular Ad Hoc Networks,” *International Conference on Communication Systems and Network Technologies (CSNT)*, doi: 10.1109/CSNT.2012.78, May 2012, Rajkot, pp. 334-338.
- [21] P. Wex *et al.*, “Trust Issues for Vehicular Ad Hoc Networks,” *IEEE Vehicular Technology Conference (VTC Spring 2008)*, Singapore, doi: 10.1109/VETECS.2008.611, May 2008, pp. 2800–2804.
- [22] F. Bai *et al.*, “Towards Characterizing and Classifying Communication-based Automotive Applications from a Wireless Networking Perspective,” *IEEE Workshop on Automotive Networking and Applications (AUTONET)*, San Francisco, Dec 2006.
- [23] *European Telecommunications Standards Institute (ETSI), Intelligent Transport Systems (ITS); Communications Architecture*, V1.1.1, September 2010.
- [24] *IEEE Draft Guide for Wireless Access in Vehicular Environments (WAVE) - Architecture*, P1609.0/D5, pp.1-74, June 2013.

- [25] UMTS Forum, "Ranking of Top 3G Services," UMTS Forum Technical Report, 2001.
- [26] A. Cuevas *et al.*, "The IMS Service Platform: A Solution for Next Generation Network Operators to Be More than Bit Pipes," *IEEE Communications Magazine*, vol. 44, no. 8, doi: 10.1109/MCOM.2006.1678113, Aug 2006, pp.75-81.
- [27] G. Camarillo and M. A. Garcia-Martin, "The 3G IP Multimedia Subsystem – Merging The Internet and The Cellular Worlds," Wiley, 3<sup>rd</sup> Edition, 2008.
- [28] G. Camarillo, "Introduction to TISPAN NGN," Ericsson, Technical Report, 2005.
- [29] M. Tadault *et al.*, "Network Evolution towards IP Multimedia Subsystem," *Alactel, Technical Report*, no. 4, 2003, pp. 81-86.
- [30] 3GPP, "Overview of 3GPP Release 5 – Summary of all Release 5 Features," 3GPP– ETSI Mobile Competence Center, Technical Report, 2003.
- [31] M. Poikselka, "The IMS Concepts and Services," Wiley, 3<sup>rd</sup> Edition, 2009.
- [32] P. Raatikainen, "Next Generation Network and Reliability," *VTT, Technical Research Centre of Finland*, Research Report VTT-R-10-1-2007, Jan 2007.
- [33] *Technical Specification Group Services and System Aspects - IP Multimedia Subsystem (IMS)*, 3GPP TS 23.228, Rel. 9, 2009.
- [34] J. Rosenberg *et al.*, "Session Initiation Protocol," RFC 3261, 2002.
- [35] *Universal Mobile Telecommunications System (UMTS)*, "Policy control over Gq interface," 3GPP TS 29.209, V6.7.0, Rel. 6, 2007.
- [36] *Digital cellular telecommunications system (Phase 2+); Universal Mobile Telecommunications System (UMTS); Telecommunications and Internet converged Services and Protocols for Advanced Networking (TISPAN); IP Multimedia Subsystem (IMS); Functional architecture*, ETSI TS 123 417, V7.0.0, 2007.
- [37] J. Jeong *et al.*, "A QoS-Aware Data Aggregation in Wireless Sensor Networks," *The 12<sup>th</sup> International on Advanced Communication Technology (ICACT)*, Phoenix Park, vol. 1, Feb 2010, pp.156–161.
- [38] M. Watfa *et al.*, "A Sensor Network Data Aggregation Technique," *International Journal of Computer Theory and Engineering*, vol. 1, no. 1, doi: 10.7763/IJCTE. 2009.V1.4, April 2009, pp.19-26.
- [39] J. Zhang *et al.*, "Effective Data Aggregation Supported by Dynamic Routing in Wireless Sensor Networks," *in Proc. of the IEEE International Conference on*

- Communications (ICC 2010)*, Cape Town, doi: 10.1109/ICC.2010.5502284, May 2010, pp. 1-6.
- [40] H. Luo *et al.*, “Data Fusion with Desired Reliability in Wireless Sensor Networks,” *IEEE Transactions on Parallel and Distributed Systems*, vol. 22, no. 3, doi: 10.1109/TPDS.2010.93, March 2011, pp.501–513.
- [41] W. R. Heinzelman *et al.*, “Energy-Efficient Communication Protocol for Wireless Microsensor Networks,” *33rd Hawaii International Conference on System Sciences*, vol. 2, doi: 10.1109/HICSS.2000.926982, Jan 2000, pp. 3005--3014.
- [42] O. Younis and S. Fahmy, “Distributed Clustering in Ad-hoc Sensor Networks: A Hybrid, Energy-Efficient Approach,” *Twenty-third Annual Joint Conference of the IEEE Computer and Communications Societies (INFOCOM 2004)*, Hong Kong, vol. 1, doi: 10.1109/INFCOM.2004.1354534, March 2004.
- [43] T. Aguilar and H. Afifi, “Two-Hops Clustering Algorithm With a Composed Metric for Wireless Sensor Networks,” *11<sup>th</sup> Wireless Personal Multimedia Communications (WPMC 08)*, Lapland, Sep 2008.
- [44] S. Lindsey and C. Raghavendra, “Data Gathering Algorithms in Sensor Networks Using Energy Metrics,” *IEEE Transactions on Parallel and Distributed Systems*, vol. 13, no. 9, doi: 10.1109/TPDS.2002.1036066, Sep 2002, pp.924-935.
- [45] S. S. Satapathy and N. Sarma, “TREEPSI: TRee based Energy Efficient Protocol for Sensor Information,” *IFIP International Conference on Wireless and Optical Communications Networks*, doi: 10.1109/WOCN.2006.1666530, Bangalore, April 2006.
- [46] M. Ding *et al.*, “Aggregation Tree Construction in Sensor Networks,” *IEEE 58<sup>th</sup> VTC 2003-Fall*, vol. 4, doi: 10.1109/VETEFCF.2003.1285913, vol. 4, Orlando, Oct 2003, pp.2168–2172.
- [47] M. Esnaashari and M. R. Meybodi, “Data Aggregation in Sensor Networks using Learning Automata,” *Wireless Networks Journal*, vol. 16, no. 3, doi: 10.1007/s11276-009-0162-5, April 2010, pp.687-699.
- [48] T. Srisooksai *et al.*, “Energy-Efficient Data Compression in Clustered Wireless Sensor Networks using Adaptive Arithmetic Coding with Low Updating Cost,” *International Journal of Information and Electronics Engineering*, vol. 1, no. 1 , July 2011, pp.85-93.

- [49] J. A. Sanchez *et al.*, “BOSS: Beacon-less on demand strategy for geographic routing in wireless sensor networks,” *The 4th International Conference on Mobile Ad-hoc and Sensor Systems (MASS)*, Pisa, Oct 2007, pp. 1–10.
- [50] T. Aguilar *et al.*, “A Cross-Layer Design Based on Geographic Information for Cooperative Wireless Networks,” *IEEE Vehicular Technology Conference*, Taipei, May 2010, pp. 1–5.
- [51] Moteiv Tmote hardware products (last seen 2012), [http://sentilla.com/files/pdf/eol/tmote\\_sky-datasheet.pdf](http://sentilla.com/files/pdf/eol/tmote_sky-datasheet.pdf).
- [52] J. Beaver *et al.*, “Location-Aware Routing for Data Aggregation in Sensor Networks,” *Proc. of Geo Sensor Networks Workshop*, 2003, pp. 189–210.
- [53] P. Beyens *et al.*, “Routing with Compression in Wireless Sensor Networks: a Q-learning Approach,” *5th European Workshop on Adaptive Agents and Multi-Agent Systems (AAMAS 05)*, Paris, March 2005.
- [54] C. Otto *et al.*, “System Architecture of a Wireless Body Area Sensor Network for Ubiquitous Health Monitoring,” *Journal of Mobile Multimedia*, vol. 1, no.4, Jan 2005, pp. 307-326.
- [55] Last seen Aug 2014, <http://technical.openmobilealliance.org/Technical/technical-information/release-program/current-releases>
- [56] E. Ko *et al.*, “Ontology-Based Context Modeling and Reasoning for U-HealthCare”, *Journal of Transactions on Information and Systems*, vol. E90-D, no. 8, doi: 10.1093/ietisy/e90-d.8.1262, Aug 2007, pp. 1262-1270.
- [57] M. Mitchell *et al.*, “Context Provider: Context Awareness for Medical Monitoring Applications”, *Conference Proc. IEEE Engineering in Medicine and Biology Society (EMBC)*, doi: 10.1109/IEMBS.2011.6091297, 2011, pp. 5244-5247.
- [58] S. Bhattacharyya *et al.*, “Context Aware Healthcare Application”, *International Journal of Computer Applications (IJCA)*, vol. 22, no. 3, doi: 10.5120/2566-3527, April 2011.
- [59] J. Kim *et al.*, “Intelligent Service Enabler based on Context-Aware in Next Generation Networks”, *International Symposium on Parallel and Distribution Processing with Applications*, Sydney, doi: 10.1109/ISPA.2008.118, Dec 2008, pp. 802-806.
- [60] F. Paganelli *et al.*, “ERMHAN: A Context-Aware Service Platform to Support Continuous Care Networks for Home-Based Assistance”, *International Journal of*

- Telemedicine and Applications*, vol. 2008, no. 4, doi:10.1155/2008/867639, Jan 2008.
- [61] F. Paganelli and D. Giuli, "An Ontology-Based System for Context-Aware and Configurable Services to Support Home-Based Continuous Care", *IEEE Transactions On Information Technology In Biomedicine*, vol. 15, no. 2, doi: 10.1109/TITB.2010.2091649, March 2011, pp. 324-333.
- [62] M. Domingo, "A Context-Aware Service Architecture for the Integration of Body Sensor Networks and Social Networks through the IP Multimedia Subsystem", *IEEE Communications Magazine*, vol. 49, no. 1, doi: 10.1109/MCOM.2011.5681022, Jan 2011, pp. 102–108.
- [63] M. Strohbach *et al.*, "A Case for IMS, Harvesting the Power of Ubiquitous Sensor Networks", *IEEE Vehicular Technology Magazine*, vol. 4, no. 1, doi: 10.1109, March 2009, pp. 57-64.
- [64] J. Vercher *et al.*, "Ubiquitous Sensor Networks in IMS: an Ambient Intelligence Telco Platform", *ICT Mobile Summit*, Estocolmo, no. 20, June 2008.
- [65] *NGN Functional Architecture; Network Attachment Subsystem (NASS)*, ETSI Standard ES 282 004, V1.3.0, (2008-6).
- [66] *Resource and Admission Control Subsystem (RACS); Functional Architecture*, ETSI Standard ES 282 003, V2.0.0, (2008-05).
- [67] *Digital cellular telecommunications system (Phase 2+); Universal Mobile Telecommunications System (UMTS); Signalling flows for the IP multimedia call control based on Session Initiation Protocol (SIP) and Session Description Protocol (SDP); Stage 3*, ETSI TS 124 228, V5.15.0, (2006-09).
- [68] Y. Kitatsuji *et al.*, "Service Initiation Procedure with On-demand UE Registration for Scalable IMS Services," *The 5<sup>th</sup> International Conference on Mobile Computing and Ubiquitous Networking (ICMU 2010)*, Seattle, April 2010.
- [69] White Paper, "High Speed Uplink Packet Access", Motorola, 2007.
- [70] S. Yousefi *et al.*, "Analytical Model for Connectivity in Vehicular Ad Hoc Networks," *IEEE Transactions on Vehicular Technology*, vol.57, no.6, July 2008, pp.3341-3356.
- [71] A. Soua *et al.*, "Analysis of information relay processing in inter-vehicle communication: A novel visit," *IEEE 8th International Conference on Wireless and Mobile Computing, Networking and Communications (WiMob)*, Barcelona, Oct 2012, pp.157,164.

- [72] A. Agarwal *et al.*, "Analytical Model for Message Propagation in Delay Tolerant Vehicular Ad Hoc Networks," *IEEE Vehicular Technology Conference, (VTC Spring 2008)*, Singapore, May 2008, pp.3067-3071.
- [73] H. Wu *et al.*, "Spatial Propagation of Information in Vehicular Networks," *IEEE Transactions on Vehicular Technology*, vol.58, no.1, Jan 2009, pp.420-431.
- [74] S. Panichpapiboon and W. Pattara-Atikom, "Connectivity Requirements for Self-Organizing Traffic Information Systems," *IEEE Transactions on Vehicular Technology*, vol.57, no.6, Nov 2008, pp.3333-3340.
- [75] J. Wu, "Connectivity Analysis of a Mobile Vehicular Ad Hoc Network with Dynamic Node Population," *IEEE GLOBECOM Workshops*, New Orleans, doi: 10.1109/GLOCOMW.2008.ECP.60, Dec 2008, pp.1-8.
- [76] M. Khabazian and M. K. Mehmet Ali, "A Performance Modeling of Connectivity in Vehicular Ad Hoc Networks," *IEEE Transactions on Vehicular Technology*, vol.57, no.4, July 2008, pp.2440-2450.
- [77] L. Liu and D.-H. Shi, "Busy Period in  $GI^X/G/1$ ," *Journal of Applied Probability*, vol. 33, no. 3, 1996, pp.815-829.
- [78] D. Miorandi and E. Altman, "Coverage and connectivity of ad hoc networks presence of channel randomness," *The 24<sup>th</sup> Annual Joint Conference of the IEEE Computer and Communications Societies Proceedings (INFOCOM 2005)*, Miami, vol.1, doi: 10.1109/INFCOM.2005.1497917, March 2005, pp.491-502.
- [79] P. C. Neelakantan and A. V. Babu, "Network Connectivity Probability of Linear Vehicular Ad Hoc Networks on Two-Way Street," *Communications and Network*, vol. 4 no. 4, 2012, doi: 10.4236/cn.2012.44038, Nov 2012, pp. 332-341.
- [80] P. C. Neelakantan and A. V. Babu "Connectivity Analysis of Vehicular Ad Hoc Networks from a Physical Layer Perspective," *Wireless Personal Communication Journal*, vol. 71, issue.1, doi: 10.1007/s11277-012-0795-z, July 2013, pp. 45-70.
- [81] A. Abdrabou and W. Zhuang, "Probabilistic Delay Control and Road Side Unit Placement for Vehicular Ad Hoc Networks with Disrupted Connectivity," *IEEE Journal on Selected Areas in Communications*, vol.29, no.1, Jan 2011, pp.129,139.
- [82] W. Zhang *et al.*, "Multi-Hop Connectivity Probability in Infrastructure-Based Vehicular Networks," *IEEE Journal on Selected Areas in Communications*, vol.30, no.4, May 2012, pp.740,747. D. Miorandi and E. Altman, "Connectivity in One-Dimensional Ad Hoc Networks: A Queueing Theoretical Approach," *Wireless Networks*, vol. 12, issue 5, Sep 2006, pp.573-587.

- [83] Y. Yao *et al.*, “Delay Analysis and Study of IEEE 802.11p based DSRC Safety Communication in a Highway Environment,” *The 32<sup>nd</sup> IEEE International Conference on Computer Communications (INFOCOM)*, Turin, doi: 10.1109/INFOCOM.2013.6566955, April 2013, pp. 1591–1599.
- [84] Y. Yao *et al.*, “Performance and Reliability Analysis of IEEE 802.11p Safety Communication in a Highway Environment,” *IEEE Transactions on Vehicular Technology*, doi: 10.1109/TVT.2013.2284594, Nov 2013, pp. 4198–4212.
- [85] Y. Toor *et al.*, “Vehicle Ad Hoc Networks: Applications and Related Technical Issues,” *IEEE Communications Surveys*, 3<sup>rd</sup> Quarter, vol. 10, no. 3, doi: 10.1109/COMST.2008.4625806, Sep 2008, pp. 74–88.
- [86] J. A. Fraile *et al.*, “Applying Wearable Solutions in Dependent Environments,” *IEEE Transactions on Information Technology in Biomedicine*, vol. 14, no. 6, Nov 2010, pp. 1459–1467.
- [87] N. Rajagopal and M. Devetsikiotis, “Modeling and Optimization for the Design of IMS Networks,” *39<sup>th</sup> Annual Simulation Symposium*, DC-USA, doi: 10.1109/ANSS.2006.27, April 2006.
- [88] L. Nagy *et al.*, “Proposal of a Queueing Model for Simulation of Advanced Telecommunication Services over IMS Architecture,” *The 36<sup>th</sup> International Conference on Telecommunications and Signal Processing (TSP)*, Rome, doi: 10.1109/TSP.2013.6613945, July 2013, pp.326–330.
- [89] S. Song *et al.*, “Modeling an NGN authentication solution and improving its performance through clustering,” *Global Communications Conference (GLOBECOM)*, Anaheim, CA, Dec 2012, pp. 2101–2106.
- [90] L. García *et al.*, “M:VIA, Smarter Vehicles and Roads by Using New Generation its Concepts and IMS Capabilities,” *The 16<sup>th</sup> ITS World Congress and Exhibition on Intelligent Transport Systems and Services*, no. 01149593, Dec 2009.
- [91] I.L.Roca *et al.*, “An IMS Based Vehicular Service Platform,” *IEEE 72<sup>nd</sup> Vehicular Technology Conference Fall (VTC 2010-Fall)*, Ottawa, doi: 10.1109/VETECF.2010.5594426, Sep 2010, pp.1–5.
- [92] M. Aly and A. Quintero, “A presence-based architecture for a gateway to integrate vehicular ad-hoc networks (VANETs), IP multimedia subsystems (IMS) and wireless sensor networks (WSNs),” *The 9<sup>th</sup> International Wireless Communications and Mobile Computing Conference (IWCMC)*, Sardinia, doi: 10.1109/IWCMC.2013.6583803, July 2013, pp.1648-1653.



- 
- [93]F. Baskett *et al.*, “Open, closed, and Mixed Networks of Queues with Different Classes of Customers,” *Journal of the ACM*, vol. 22, issue 2, 1975, pp. 248-260.

## Appendix A: Demonstration of Theorem 2 (Chapter 5)

Let defining the following notations:

$$b_i = \rho'^i \left( \sum_{j=0}^i (-1)^j \frac{\lambda'^j}{j!} C_{2i-j}^i \right) \quad (\text{A.1})$$

$$c_i = \rho'^i C_{2i-1}^i \quad (\text{A.2})$$

$$a_{2k,i} = \rho'^{k-1} (-1)^i C_{2k-i-3}^{k-2} \quad (\text{A.3})$$

$$a_{2k+1,i} = \rho'^i (-1)^i C_{2k-i-1}^{k-1} \quad (\text{A.4})$$

Let also define the following z-transform:

$$\forall i > 0, A_i^{(e)}(z) = \sum_{k=i+1}^{+\infty} a_{2k,i} z^{2k} \quad (\text{A.5})$$

$$A_0^{(e)}(z) = \sum_{k=2}^{+\infty} a_{2k,0} z^{2k} \quad (\text{A.6})$$

$$\forall i > 0, A_i^o(z) = \sum_{k=i}^{+\infty} a_{2k+1,i} z^{2k+1} \quad (\text{A.7})$$

$$A_0^o(z) = \sum_{k=1}^{+\infty} a_{2k+1,0} z^{2k+1} \quad (\text{A.8})$$

**Lemma 1:** The series  $\sum^{+\infty} b_i z^{2i+1}$  converges for  $\lambda' > \ln 4 + \ln z^2$ .

**Proof:**

$$\begin{aligned} b_i &= \rho'^i \left( \sum_{j=0}^i (-1)^j \frac{\lambda'^j}{j!} C_{2i-j}^i \right) \\ &= \rho'^i \left( C_{2i}^i \sum_{j=0}^i \frac{(-\lambda')^j}{j!} \frac{C_{2i-j}^i}{C_{2i}^i} \right) \\ &= \rho'^i \left( C_{2i}^i \sum_{j=0}^i \frac{(-\lambda')^j}{j!} \frac{(2i-j)! i!}{(2i)!(i-j)!} \right) \end{aligned} \quad (\text{A.9})$$

But,  $\sum_{j=0}^i \frac{(-\lambda')^j}{j!} \frac{(2i-j)! i!}{(2i)!(i-j)!}$  is bounded because,

$$\frac{(2i-j)! i!}{(2i)!(i-j)!} = \frac{i(i-1)\dots(j+1)}{2i(2i-1)\dots(j+1)} < 1 \quad (\text{A.10})$$

Moreover, in the neighborhood of  $+\infty$ , by denoting  $Cst$  a constant term and using Stirling's formula, the following equation is obtained:

$$\begin{aligned} b_i z^{2i+1} &\sim \rho'^i Cst \times C_{2i}^i z^{2i+1} \\ &\sim \rho'^i Cst \frac{(2i)!}{i! i!} z^{2i+1} \end{aligned}$$

$$\begin{aligned}
&\sim \rho'^i Cst \frac{\sqrt{2\pi 2i} \left(\frac{2i}{e}\right)^{2i}}{\left[\sqrt{2\pi i} \left(\frac{i}{e}\right)^i\right]^2} z^{2i+1} \\
&\sim Cst \frac{e^{i\ln 4 - i\lambda'}}{\sqrt{\pi i}} z^{2i+1}
\end{aligned} \tag{A.11}$$

Then,  $\sum^{+\infty} b_i z^{2i+1}$  converges if and only if  $\lambda' > \ln 4 + 2\ln z$ .

Similarly, it can be shown that the other sums converges only when  $\lambda' > \ln 4$  for  $z$  in the neighborhood of 1. Then, for  $\lambda' > \ln 4$  for  $z$  in the neighborhood of 1, the following lemma is obtained.

**Lemma 2:**

$$\begin{aligned}
M_1(z) &= \frac{1}{\rho z^2 [1 - b_0 z + \sum_{i=1}^{+\infty} (c_i z^{2i} - b_i z^{2i+1})]} \times \\
&\quad \left[ (z-1) \sum_{i=1}^{+\infty} \frac{\lambda'^i}{i!} (\mathfrak{M}_{i,1} A_i^{(o)}(z) + \mathfrak{M}_{i,2} A_i^{(e)}(z)) \right] \\
&\quad + (\mathfrak{M}_{0,1} z + \mathfrak{M}_{0,2} z - \mathfrak{M}_{0,1} z^2) \sum_{i=1}^{+\infty} c_i z^{2i} \\
&\quad + \mathfrak{M}_{0,2} (1 - b_0) z^3 - \mathfrak{M}_{0,2} z \sum_{i=1}^{+\infty} b_i z^{2i+1}
\end{aligned} \tag{A.12}$$

Where for all  $\alpha \geq 0$ ,

$$\mathfrak{M}_{\alpha,1} = \sum_{i=0}^{\alpha} \frac{(-1)^i \alpha!}{(\alpha-i)!} \frac{1}{\lambda'^i} + (-1)^{\alpha+1} \frac{\alpha!}{\lambda'^{\alpha}} \rho' \tag{A.13}$$

And for all  $\alpha \geq 0$

$$\mathfrak{M}_{\alpha,2} = \sum_{i=0}^{\alpha} \frac{(-1)^i \alpha!}{(\alpha-i)!} \frac{1}{\lambda'^i} - \frac{\rho}{\alpha+1} - (-1)^{\alpha} \frac{\alpha!}{\lambda'^{\alpha}} \rho' \tag{A.14}$$

The proof is in Appendix B.

By combining lemmas 3, 4, 5 and 6, this expression of  $M_1(z)$  can be simplifies into Eq. (5.21).

Let

$$u_{\alpha,k} = \frac{\lambda'^{\alpha}}{\alpha!} \mathfrak{M}_{\alpha,k} \tag{A.15}$$

**Lemma 3:** if  $\lambda R \geq \ln 4$ ,

$$\sum_{\alpha=1}^{+\infty} u_{\alpha-1} A_{\alpha}^{(o)}(z) = \frac{f(z)}{1 + \frac{1}{2}g(z)} \left[ \frac{1}{2}g(z)(\rho' - 1) + e^{\frac{1}{2}\lambda'g(z)} - 1 \right] \tag{A.16}$$

Where

$$f(z) = \frac{2z(\rho' z^2)}{\sqrt{1 - 4\rho' z^2 - (1 - \rho z^2)}} \tag{A.17}$$

And

$$g(z) = \sqrt{1 - 4\rho'z^2} - 1 \quad (\text{A.18})$$

**Proof:** from equations (A.4) and (A.7),  $\forall i > 0$

$$A_i^{(o)}(z) = \rho'^i (-1)^i z^{2i+1} \sum_{k=0}^{+\infty} \rho'^k C_{2k+i-1}^k z^{2k} \quad (\text{A.19})$$

But,

$$\frac{\rho'^{k+1} C_{2(k+1)+i-1}^{k+1}}{\rho'^k C_{2k+i-1}^k} = 4\rho' \frac{\left[ k + \frac{i+1}{2} \right] \left[ k + \frac{i}{2} \right]}{(k+1)(k+i)} \quad (\text{A.20})$$

So that the series  $\sum_{k=0}^{+\infty} \rho'^k C_{2k+i-1}^k z^{2k}$  is the hyper-geometric series

$$\sum_{k=0}^{+\infty} \rho'^k C_{2k+i-1}^k z^{2k} = {}_2F_1 \left( \frac{1+i}{2}, \frac{i}{2}, i, 4\rho'z^2 \right) \quad (\text{A.21})$$

Also,

$${}_2F_1 \left( a, b, 2b, \frac{4u}{(u+1)^2} \right) = (u+1)^{2a} {}_2F_1 \left( a, a - b + \frac{1}{2}, b + \frac{1}{2}, u^2 \right) \quad (\text{A.22})$$

and

$${}_2F_1(a, 1, a, u^2) = (1 - u^2)^{-1} \quad (\text{A.23})$$

Thus, by choosing  $u$  so that,

$$\frac{4u}{(u+1)^2} = 4\rho'z^2 \quad (\text{A.24})$$

and

$$\forall i > 0, A_i^{(o)}(z) = f(z) \frac{1}{2^i} g(z)^i \quad (\text{A.25})$$

Finally,

$$\begin{aligned} \sum_{\alpha=1}^{+\infty} u_{\alpha,1} A_{\alpha}^{(o)}(z) \\ = \sum_{\alpha=1}^{+\infty} (-1)^{\alpha} \left[ \sum_{j=0}^{\alpha} (-1)^{\alpha-j} \frac{\lambda'^j}{j!} - \rho' \right] f(z) \frac{1}{2^{\alpha}} g(z)^{\alpha} \end{aligned} \quad (\text{A.26})$$

And noting that

$$\sum_{\alpha=1}^{+\infty} \sum_{j=0}^{\alpha} v_j w_{\alpha} = \sum_{\alpha=1}^{+\infty} v_0 w_{\alpha} + \sum_{j=1}^{+\infty} \sum_{\alpha=j}^{+\infty} v_j w_{\alpha} \quad (\text{A.27})$$

Where  $(u)_n$  and  $(v_n)$  are two arbitrary sequence, Eq. (A.16) is obtained. There is an exist  $u$  solution of Eq. (A.24) only if  $\lambda R \geq 4$ .

Similarly, by noting that  $a_{2k,i} = a_{2k-1,i}$ , the following lemma can be proved.

**Lemma 4:** if  $\lambda R \geq 4$

$$\begin{aligned} \sum_{\alpha=1}^{+\infty} u_{\alpha,2} A_{\alpha}^{(e)}(z) &= \frac{2\rho'zf(z)}{g(z)} \left[ 1 + \frac{1}{2} \lambda' g(z) - e^{\frac{1}{2} \lambda' g(z)} \right] \\ &+ \frac{1}{2} (\rho' - 1) \frac{zf(z)g(z)}{1 + \frac{1}{2} g(z)} + zf(z) \frac{e^{\frac{1}{2} \lambda' g(z)} - 1}{1 + \frac{1}{2} g(z)} \end{aligned} \quad (\text{A.28})$$

**Lemma 5:** if  $\lambda R \geq 4$

$$\sum_{i=1}^{+\infty} c_i z^{2i} = \frac{1}{4\rho'z^3} f(z)g(z)^2 \quad (\text{A.29})$$

**Proof:** on one hand,

$$\sum_{i=1}^{+\infty} c_i z^{2i} = \rho'z^2 {}_2F_1\left(\frac{3}{2}, 1, 2, 4\rho'z^2\right) \quad (\text{A.30})$$

and on the other hand,

$${}_2F_1\left(\frac{3}{2}, 1, 2, \frac{4u}{(1+u)^2}\right) = (u+1)^3 {}_2F_1\left(\frac{3}{2}, 1, \frac{3}{2}, u^2\right) = \frac{(u+1)^3}{1-u^2} \quad (\text{A.31})$$

Thus, with  $u$  solution of Eq. (A.24) and Eq. (A.29) as proved.

**Lemma 6:** if  $\lambda R \geq 4$

$$\sum_{i=1}^{+\infty} b_i z^{2i+1} = \frac{z \left[ e^{\frac{1}{2}\lambda'g(z)} - g(z) - 1 \right]}{1+g(z)} \quad (\text{A.32})$$

**Proof:** this lemma can be proved using identity of Eq. (A.27) and the following equations:

$${}_2F_1\left(\frac{1}{2}, 1, 1, 4\rho'z^2\right) = \frac{1}{\sqrt{1-4\rho'z^2}} \quad (\text{A.33})$$

And

$$\begin{aligned} {}_2F_1\left(a, b, 2b, \frac{4u}{(1+u)^2}\right) \\ = (1+u)^{2a} {}_2F_1\left(a, a-b+\frac{1}{2}, b+\frac{1}{2}, u^2\right) \end{aligned} \quad (\text{A.34})$$

## Appendix B: Demonstration of Lemma 2 (Chapter 5)

In this section,  $M_1(z)$  is derived. To find the elements of the series  $(\mathfrak{M}_{1,k})_k$  it is necessary to solve the double recurrence, both in  $\alpha$  and  $k$  that is why it will be proceeded in two steps. The set of the positive values of  $\alpha$  and  $k$  constitutes a quarter plane. In the first step, it will be binged back the recurrence in the borders of the quarter plane by eliminating the terms of  $\mathfrak{M}_{\alpha,k}$  for which  $\alpha > 0$  and  $k > 2$  and keep only the terms of the form  $\mathfrak{M}_{0,k}$  for  $k > 2$  and in terms of the form  $\mathfrak{M}_{\alpha,1}$  or  $\mathfrak{M}_{\alpha,2}$ . Actually,  $\mathfrak{M}_{\alpha,1}$  and  $\mathfrak{M}_{\alpha,2}$  are easy to be calculated. By this way, a new recurrence expression  $\mathfrak{M}_{0,k}$  will be obtained in function of  $\mathfrak{M}_{0,i}$  where  $i < k$ ,  $\mathfrak{M}_{\alpha,1}$  or  $\mathfrak{M}_{\alpha,2}$ . In the second step, this last recurrence will be solved in order to find  $\mathfrak{M}_{0,k}$  in function of the  $\mathfrak{M}_{\alpha,1}$  and  $\mathfrak{M}_{\alpha,2}$ . Then, using Eq. (5.18), it is easy to deduce  $\mathfrak{M}_{1,k}$ .

### First step: expressing $\mathfrak{M}_{0,k}$ in function of $\mathfrak{M}_{0,i}$ , $i < k$ , $\mathfrak{M}_{\alpha,1}$ and $\mathfrak{M}_{\alpha,2}$

By injecting Eq. (A.15) in equations (5.18) and (5.19), a simpler system is obtained as follows:

$$\begin{cases} u_{0,k} = u_{0,k-1} - \rho' u_{1,k-2} & \text{(B.1)} \\ u_{\alpha,k} = \frac{\lambda'^\alpha}{\alpha!} u_{0,k-1} - u_{\alpha-1,k} - \rho' u_{\alpha+1,k-2} & \text{(B.2)} \end{cases}$$

Let  $V_k(z)$  be the  $z$ -transform of  $u_{\alpha,k}$  relatively to  $\alpha$ :

$$V_k(z) = \sum_{\alpha=0}^{+\infty} u_{\alpha,k} z^\alpha \quad \text{(B.3)}$$

Multiplying Eq. (B.2) by  $z^\alpha$  and summing over  $\alpha \geq 1$ ,

$$V_k(z) = \frac{e^{\lambda'z}}{1+z} u_{0,k-1} + \frac{\rho'}{z(1+z)} u_{0,k-2} - \frac{\rho'}{z(1+z)} V_{k-2}(z) \quad \text{(B.4)}$$

By recurrence,

$$\begin{aligned} V_{2k}(z) &= \left[ -\frac{\rho'}{z(1+z)} \right]^{k-1} V_2(z) - \sum_{i=1}^{k-1} \left[ -\frac{\rho'}{z(1+z)} \right]^i u_{0,2(k-i)} \\ &\quad + \frac{e^{\lambda'z}}{1+z} \sum_{i=0}^{k-2} \left[ -\frac{\rho'}{z(1+z)} \right]^i u_{0,2(k-i)-1} \end{aligned} \quad \text{(B.5)}$$

$$V_{2k+1}(z) = \left[ -\frac{\rho'}{z(1+z)} \right]^{k-1} V_1(z) - \sum_{i=1}^{k-1} \left[ -\frac{\rho'}{z(1+z)} \right]^i u_{0,2(k-i)+1}$$

$$+ \frac{e^{\lambda'z}}{1+z} \sum_{i=0}^{k-1} \left[ -\frac{\rho'}{z(1+z)} \right]^i u_{0,2(k-i)} \quad (\text{B.6})$$

In order to find the elements of the type  $u_{0,k}$ , the 0 degree in  $z$  of these equations should be extracted. Knowing that:

$$\forall z \in ]-1; +1[, (1+z)^{-\alpha} = 1 + \sum_{n=1}^{+\infty} (-1)^n C_{\alpha+n-1}^n z^n \quad (\text{B.7})$$

Equating the 0 degrees in  $z$  of both sides of Eq. (B.5) gives:

$$\begin{aligned} u_{0,2k} = & \rho'^{k-1} \sum_{i=0}^{k-1} (-1)^i C_{2k-i-3}^{k-2} u_{i,2} - \sum_{i=1}^{k-1} \rho'^i C_{2i-1}^i u_{0,2(k-i)} \\ & + \sum_{i=0}^{k-2} \rho'^i \left( \sum_{j=0}^i (-1)^j \frac{\lambda'^j}{j!} C_{2i-j}^i \right) u_{0,2(k-i)-1} \end{aligned} \quad (\text{B.8})$$

and the same for Eq. (B.6):

$$\begin{aligned} u_{0,2k+1} = & \rho'^k \sum_{i=0}^k (-1)^i C_{2k-i-1}^{k-1} u_{i,1} - \sum_{i=1}^k \rho'^i C_{2i-1}^i u_{0,2(k-i)+1} \\ & + \sum_{i=0}^{k-1} \rho'^i \left( \sum_{j=0}^i (-1)^j \frac{\lambda'^j}{j!} C_{2i-j}^i \right) u_{0,2(k-i)} \end{aligned} \quad (\text{B.9})$$

Now, the system of equation (B.8) and (B.9) gives an expression of  $u_{0,k}$  in function of  $u_{0,i}$  for  $i < k$ . In the next step, the recurrence is solved by searching the  $z$ -transform  $U_0(z)$  of  $u_{0,k}$  and make the link between  $U_0(z)$  and  $M_1(z)$ .

### Second step: is to find $M_1(z)$

let us define the following  $z$ -transforms:

$$U_0^{(e)}(z) = \sum_{k=1}^{+\infty} u_{0,2k} z^{2k} \quad (\text{B.10})$$

$$U_0^{(o)}(z) = \sum_{k=0}^{+\infty} u_{0,2k+1} z^{2k+1} \quad (\text{B.11})$$

$$U_0(z) = U_0^{(e)}(z) + U_0^{(o)}(z) \quad (\text{B.12})$$

$$\forall i \geq 0, U_i(z) = \sum_{k=0}^{+\infty} u_{i,k} z^k \quad (\text{B.13})$$

Then, using notations (A.1), (A.2), (A.3), and (A.4), the system of equations (B.8) and (B.9) becomes:

$$\left\{ \begin{aligned} u_{0,2k} = & \sum_{i=0}^{k-1} a_{2k,i} u_{i,2} + \sum_{i=0}^{k-2} b_i u_{0,2(k-i)-1} - \sum_{i=1}^{k-1} c_i u_{0,2(k-i)} \end{aligned} \right. \quad (\text{B.14})$$

$$\left\{ \begin{aligned} u_{0,2k+1} = & \sum_{i=0}^k a_{2k+1,i} u_{i,1} + \sum_{i=0}^{k-1} b_i u_{0,2(k-i)} - \sum_{i=1}^k c_i u_{0,2(k-i)+1} \end{aligned} \right. \quad (\text{B.15})$$

Multiplying Eq. (B.14) by  $z^{2k}$  and summing for  $k \geq 1$ , multiplying Eq. (B.15) and summing for  $k \geq 2$  and summing both leads to:

$$\begin{aligned} \sum_{k \geq 3}^{+\infty} u_{0,k} z^k &= \sum_{i=0}^{+\infty} [u_{i,1} A_i^{(o)}(z) + u_{i,2} A_i^{(e)}(z)] - u_{0,1} z \sum_{i=0}^{+\infty} b_i z^{2i+1} \\ &+ [U_0^{(e)}(z) + U_0^{(o)}(z)] [\sum_{i=0}^{+\infty} b_i z^{2i+1} - \sum_{i=1}^{+\infty} c_i z^{2i}] \end{aligned} \quad (\text{B.16})$$

Or, equivalently

$$\begin{aligned} U_0(z) &\left[ 1 - b_0 z + \sum_{i=1}^{+\infty} (c_i z^{2i} - b_i z^{2i+1}) \right] \\ &= \sum_{i=0}^{+\infty} [u_{i,1} A_i^{(o)}(z) + u_{i,2} A_i^{(e)}(z)] + u_{0,1} z + u_{0,2} z^2 - u_{0,1} z \sum_{i=0}^{+\infty} b_i z^{2i+1} \end{aligned} \quad (\text{B.17})$$

Moreover, multiplying Eq. (B.1) by  $z^k$  for every  $k$  and summing for all  $k \geq 3$  leads to:

$$U_0(z) - u_{0,2} z^2 - u_{0,1} z = z [U_0(z) - u_{0,1} z] - \rho' z^2 U_1(z) \quad (\text{B.18})$$

and, since  $\mathfrak{M}_{1,k} = u_{1,k} \times \frac{1!}{\lambda^k}$ ,

$$M_1(z) = \frac{1}{\lambda'} U_1(z) \quad (\text{B.19})$$

Combining Equations (B.18) and (B.19),

$$M_1(z) = \frac{u_{0,2} - u_{0,1}}{\rho} + \frac{u_{0,1}}{\rho} \frac{1}{z} + \frac{z-1}{\rho z^2} U_0(z) \quad (\text{B.20})$$

Finally, thanks to Eq. (B.17),

$$\begin{aligned} M_1(z) &= \frac{1}{\rho z^2 [1 - b_0 z + \sum_{i=1}^{+\infty} (c_i z^{2i} - b_i z^{2i+1})]} \times \\ &\left[ (z-1) \sum_{i=1}^{+\infty} (u_{i,1} A_i^{(o)}(z) + u_{i,2} A_i^{(e)}(z)) + (u_{0,1} z + u_{0,2} z - u_{0,1} z^2) \sum_{i=1}^{+\infty} c_i z^{2i} + \right. \\ &\quad \left. u_{0,2} (1 - b_0) z^3 - u_{0,2} \sum_{i=1}^{+\infty} b_i z^{2i+1} \right] \end{aligned} \quad (\text{B.21})$$

Replacing  $u_{\alpha,k}$  by  $\mathfrak{M}_{\alpha,k}$ , Eq. (A.12) is obtained,

Finally, by integrating by parts,  $\mathfrak{M}_{\alpha,1} = 1 - \frac{\alpha}{\lambda'} \mathfrak{M}_{\alpha-1,1}$  and  $\mathfrak{M}_{\alpha,2} = 1 - \rho' - \frac{\rho}{\alpha+1} \mathfrak{M}_{\alpha-1,2}$ . Then, by recurrence equations, (A.13) and (A.14) are obtained.



## Appendix C: Résumé de Thèse

### C.1 Introduction générale

De nos jours, la plupart des applications essayent de bien exploiter l'information. La propagation rapide de la technologie de l'information permet de maximiser la quantité de l'information échangée. Les volumes de stockage de données se développent au-delà de 50% par an. Cette croissance devrait se poursuivre en raison de vaste prolifération des systèmes d'information existants et l'introduction de nouvelles sources de données. Le réseau de capteurs ubiquitaires (USN) est utilisé pour décrire un réseau de capteurs intelligents. L'USN peut utiliser les réseaux de capteurs filaires et / ou des réseaux de capteurs sans fil (WSN).

De WSN est l'un des exemples les plus significatifs de ces nouvelles sources de données. Au cours des dernières années, différents types de réseaux de capteurs ont été déployés et la quantité d'informations générées par les capteurs sans fil augmente rapidement. L'explosion de l'information peut nécessiter d'agrèger les données et leur traitement afin de réduire le volume des messages échangés.

D'autre part, la tendance dans l'apprêt des services de communication est à la convergence qui irise à faire converger tous les types de services sous un seul cadre qui est le réseau de prochaine génération (NGN).

L'idée générale derrière le NGN est que toutes les informations sont transmises par paquets, comme dans l'Internet; les paquets sont étiquetés en fonction de leur type (données, voix...etc.) et traités différemment pour des raisons liées à la sécurité et la qualité de service (QoS). Le NGN doit fournir les moyens (infrastructure, protocoles, etc.) pour réaliser la conception, le déploiement et la gestion de tous les types de services possibles. Les services avec différents besoins en bande passante de quelques kbit/s à des centaines de Mbit/s, garantis ou non, doivent être pris en charge. Dans le NGN, on s'intéresse de plus au service personnalisé. Les fournisseurs des services offrent à leurs clients la possibilité de personnaliser leurs propres services. Le NGN devrait être composé d'API de service (Interfaces de programmation d'application) afin de soutenir la création, l'approvisionnement et la gestion des services.

L'un des systèmes les plus importants dans la strate des services NGN est le sous-système multimédia IP (IMS). L'IMS est un cadre architectural pour la prestation de services multimédias IP. Il a été conçu à l'origine par l'organisme de normalisation sans fil 3<sup>rd</sup> Generation Partnership Project (3GPP), comme une partie de la vision de l'évolution des réseaux mobiles GSM. Sa formulation originale (3GPP Rel-5) a représenté une approche de prestation de services "Internet" sur GPRS. Cette vision a été plus tard mise à jour par le 3GPP, 3GPP2 et ETSI TISPAN en exigeant le soutien des réseaux autres que le GPRS, tels que LAN sans fil, CDMA2000 et les lignes fixes.

Dans notre thèse, nous avons proposé de construire l'application e-santé sur IMS exploitant les différentes données fournies par l'USN. Nous avons présenté des solutions pour les défis convergents entre les deux réseaux. La santé et le bien-être sont des questions importantes pour les particuliers et le public, car une vie saine et un état de bien-être sont évidemment souhaitable. Sur ce chemin, nous avons proposé une nouvelle architecture réseau et de service en suivant l'architecture de réseau NGN-IMS et selon les exigences de l'USN. En outre, envie de fournir l'e-santé partout et à tout moment, nous avons proposé une application de sécurité à appliquer sur le réseau Ad-hoc de véhicules (VANET) qui pourrait être facilement convergé et contrôlé par notre architecture de service proposé.

Les principales contributions de cette thèse sont résumées ci-dessous :

- Protocole d'agrégation dynamique pour les réseaux de capteurs: Nous avons cherché à fournir les informations qui peut être exploitées dans la création d'applications de santé sur le réseau NGN-IMS. D'une part, le WSN souffre de nombreuses limitations telles que la faible capacité et les problèmes d'énergie. D'autre part, il est préférable de réduire le nombre de messages transmis à la plate-forme IMS pour deux raisons. Tout d'abord, afin de minimiser l'énergie utilisée par les réseaux de capteurs et donc prolonger la durée de vie du réseau. Et aussi, pour diminuer le temps de traitement prévu sur le réseau de base en raison de l'énorme quantité de messages reçus. Par conséquent, nous proposons dans cette contribution un nouveau protocole d'agrégation dynamique (DAP) qui peut être appliqué sur le WSN. En outre, nous avons proposé une récupération de données intelligente.
- Évaluation du nouveau modèle de signalisation Modèle de l'e-Santé dans l'environnement USN : cette contribution a donné lieu à la publication de deuse

articles. Nous avons proposé l'utilisation d'IMS en tant que sous-couche de contrôle de service dans l'environnement USN. Nous avons proposé une conception détaillée du réseau et nous avons mis en œuvre l'application proposée, composant de nouvelles entités fonctionnelles pour la couche application. Cette solution est simple, flexible, et ne nécessite pas de grands changements dans les réseaux de communication déjà établis. Afin de compléter cette proposition, nous avons développé un organigramme détaillé de signalisation de réseau pour différents scénarios e-santé applicables en utilisant SIP. Selon le flux de signalisation développé, nous avons proposé une modification du protocole SIP pour correspondre aux caractéristiques prévues dans le service e-santé proposé. En outre, nous avons présenté quatre détections de cas d'urgence, qui sont pratiquement indispensables pour sauver la vie des patients.

- Une modélisation Interactive des applications temps réel dans VANETs avec évaluation des performances : Dans ce travail nous avons proposé l'intégration du VANET dans notre précédente application de sécurité en utilisant l'IMS comme contrôleur de service. Nous avons utilisé nos travaux précédents liés à l'architecture de réseau afin de faire converger l'USN et le VANET sur l'IMS. Etant donné que les applications de sécurité sont sensibles au retard de transmission, le temps pris par une alerte à envoyer jusqu'à ce qu'une réponse soit reçue est très critique. Ce temps est appelé RTT. Pour calculer le RTT de bout en bout, nous l'avons décomposé en deux parties. Le premier délai concerne le lien de connexion entre les véhicules sur les routes et calcule le nombre de sauts entre deux nœuds proposés. Cette approche donne une bonne durée moyenne du délai de communication entre les deux nœuds mentionnés. Le second modélise la performance du réseau cœur IMS à partir de la réception du message d'alerte du RSU afin de calculer le temps moyen d'initialisation l'application de santé VANET sur l'IMS.

## **C.2 Analyses des contributions de la thèse**

Dans cette partie, nous détaillons les différentes contributions de la thèse en se basant sur les objectifs et les résultats obtenus:

## C.2.1 DAP: Protocole d'agregation dynamique de capteurs Sans Fil

Notre contribution principale consiste à développer une plateforme haute capacité pour de nouvelles applications basées sur l'IMS/NGN exploitant l'information fournie par le WSN. En effet, tel quel le réseau de capteurs risque d'envoyer énormément de paquets. Par conséquent, nous proposons un nouveau protocole d'agregation qui vise atténuer de ce problème d'explosion de nombre de paquets, et aider à prolonger la vie de WSN.

Le mécanisme DAP est un protocole hybride d'agregation de données, compromis l'entrée de la chaîne et approche de groupe. C'est un protocole dynamique puisque le chemin d'agregation est sélectionné de façon dynamique selon le procédé de contention décrit ci-après.

### C.2.1.1 Description de l'algorithme

Considérons un nœud ayant des données détectées et qui a besoin de les envoyer au puits. Le nœud passera par étapes suivantes pour fournir ses données d'information au puits :

**Étape 1:** L'initiateur du processus d'agregation est le premier capteur ayant un message de données à envoyer au puits.

**Étape 2:** Ce nœud initiateur diffuse un message demandant à tous les nœuds autour de lui: "qui peut être mon prochain saut vers le puits?".

**Étape 3:** Les nœuds autour de lui reçoivent ce message et donc lancent un processus de contention pour élire l'un d'entre eux (vainqueur de conflit) pour gérer la transmission des données du nœud source.

Selon les règles de l'algorithme et afin d'optimiser les performances du protocole, chaque nœud recevant ce message de contention doit être conforme aux conditions suivantes pour participer au processus de contention:

- Il doit avoir son propre message de données (i.e. des données à envoyer), qui doit être envoyé également au puits quel que soit le type de ce message de données. Cette condition sert à conserver l'énergie des nœuds idle pour leurs activités uniquement. Il n'y a pas de condition sur le type de données à relayer des relais, i.e. le processus d'agregation de données ne dépend pas du type des capteurs.

- Il doit avoir suffisamment d'énergie résiduelle pour les fonctions de traitement et de transmission. Ces contraintes sont essentielles afin de s'assurer que le nœud destinataire est capable de terminer cette tâche avec succès.
- La distance entre le puits et le nœud qui accepte de participer au processus de contention doit être inférieure à celle entre le nœud source et le puits, qui peut être déterminé comme dans [44]. Cette condition présente l'avantage de rendre le chemin d'agrégation le plus court possible et d'empêcher que les transmissions soient dans le cycle d'une boucle. Pour l'application de cette condition, chaque candidat peut décider d'entrer dans le processus de contention ou non en calculant la distance euclidienne facilement en utilisant l'équation (1):

$$P(S, D, F) = dist(F, D) - dist(S, D) \quad (1)$$

où S, D, et F représentent respectivement la source, la destination et le nœud qui retransmet. Si la valeur de l'éq. (1) est négative, cela signifie que le nœud de retransmission est plus près du puits que la source et par conséquent, convient. Sinon, ce nœud est plus loin du puits que la source et ne peut pas entrer dans le processus de contention.

- Ce nœud doit vérifier le niveau de qualité de lien et d'énergie reçue ( $LQI/ED$ ) pour s'assurer qu'il reçoit le signal du nœud source avec un bon SNR, ce qui élimine la nécessité de retransmissions et économise ainsi la puissance des nœuds capteurs et prolonge leur durée de vie.

Ensuite, après avoir rempli ces conditions:

**Etape 4:** chaque nœud conforme démarre un compteur de temporisation suivant l'équation (2), et les deux premiers nœuds dont les compteurs expriment envoient un message de diffusion informant le nœud source et l'autre voisin dans les environs. Puis, le premier vainqueur de conflit sera considéré comme le nœud de transfert suivant (next hop), et le deuxième gagnant servira de relais pour la source dans le cas où son message est reçu endommagé au niveau du nœud de transfert ou perdu. Ainsi, nous avons deux nœuds relais maintenant, le premier lauréat est le relais principal, et le deuxième gagnant est ulvi de secours pour la récupération des données de ce relais principal.

$$T_R = \left( \frac{T_{\max}}{L + E} \right) - rand \left( \frac{T_{\max} / 2}{L + E} \right) \quad (2)$$

où  $L$  et  $E$  sont les LQI / ED et l'énergie résiduelle.  $L$  et  $E$  sont normalisés entre  $\in (0,1)$ .  $T_{\max}$  représente le temps maximum que le nœud source doit attendre afin qu'un nœud selai envoie sa réponse. La fonction  $\text{rand}(x)$  génère une valeur aléatoire entre 0 et  $x$ . Cette fonction est ajoutée pour éviter d'avoir plus d'un gagnant avec des valeurs égales, et donc atténue les collisions de processus de contention qui pourraient survenir entre les nœuds des mêmes paramètres.

**Étape 5:** lorsque les nœuds dans le voisinage reçoivent deux messages « gagnant », ils arrêtent leurs compteurs. Dans le cas où il ya des nœuds participant au processus de contention et en dehors de la portée de communication des gagnants, ils ne reçoivent pas les messages diffusés. Cependant, ces nœuds détecteront fin aliment le résultat de l'élection lorsque le nœud source commençera à envoyer son message de données au vainqueur de conflit et donc ils arrêteront leurs chronomètres. Le fonctionnement du deuxième gagnant (relais secondaire) est expliqué dans la section suivante.

**Étape 6:** les nœuds voisins arrêtent leurs compteurs. Le gagnant sera considéré comme l'agrégateur de données pour ce voisinage. Ces nœuds commencent à envoyer leurs données à ce gagnant en tant que prochain saut au puits.

**Étape 7:** le gagnant commence à traiter les messages reçus. En utilisant les statistiques, le relai suivant combine, compresse et supprime la redondance en réponse aux messages reçus dans un petit paquet approprié pour la transmission. Ceci est fait indépendamment du type de données des messages comme nous l'avons mentionné ci-dessus.

**Étape 8:** le nœud gagnant devient la nouvelle source de données et doit passer son message au puits. Il répète les étapes 2 à 7 jusqu'à ce que le message de données soit livré au prochain saut. L'ensemble du processus est répété jusqu'à ce que le paquet atteigne le puits.

### **C.2.1.2 Comparaison de DAP avec l'agrégation de données basée sur un apprentissage par automates**

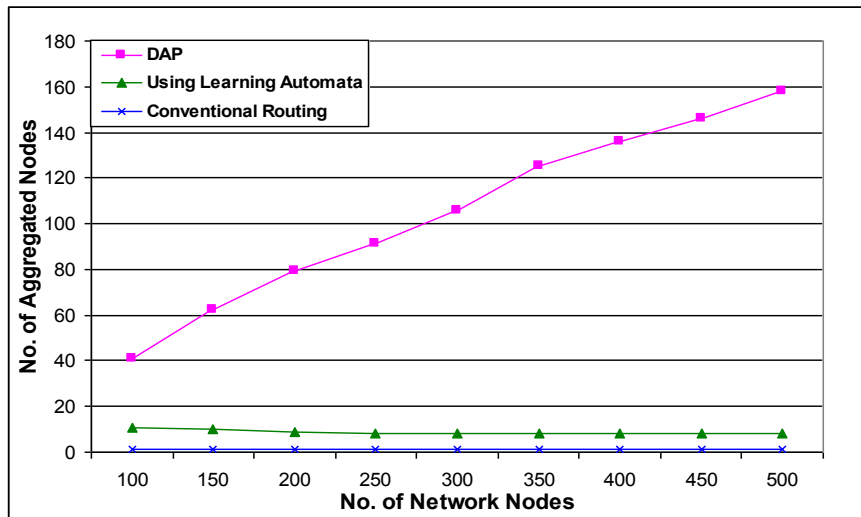
- DAP établit chaque nœud le long du trajet d'agrégation (plus court chemin) comme un arrêt temporaire pour les messages collectés des capteurs, ce qui augmente le taux d'agrégation. A l'inverse, un protocole basé sur l'apprentissage par automates collecte les messages de données des nœuds du chemin.
- DAP permet l'agrégation de données de différents types de capteurs qui maximise le taux d'agrégation, tandis que l'agrégation de donnée basée sur

l'apprentissage par automates se concentre seulement sur les nœuds similaires. Cela a pour effet que tous les groupes de nœuds d'un même type de données à son propre chemin pour agréger les informations captées, ce qui double théoriquement le coût de l'agrégation.

- DAP établit le plus court chemin vers le puits en parallèle avec le processus d'agrégation c'est-à-dire qu'il effectue ces deux fonctions (découverte de chemin et processus d'agrégation) en une seule étape, tandis que le protocole d'agrégation de données basé sur l'apprentissage par automates exécute une fonction à la fois en deux phases.

### C.2.1.3 Évaluation de performances

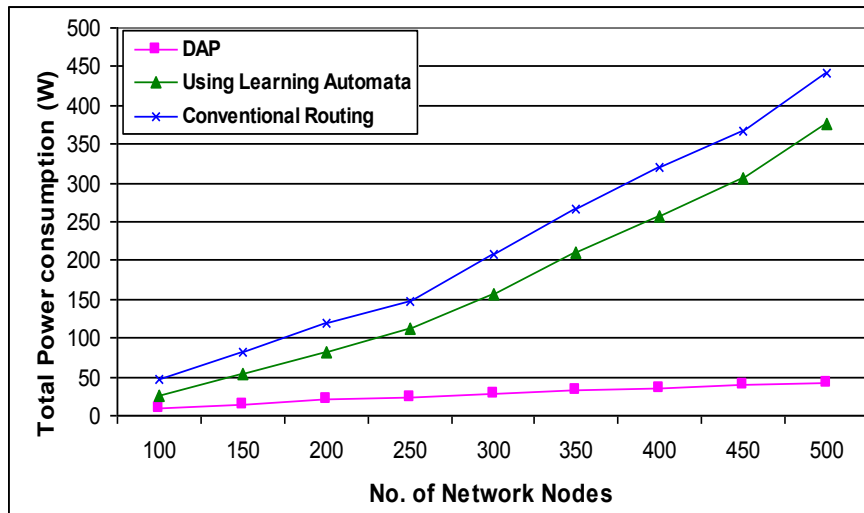
**Expérience 1:** Dans ce scénario, l'effet du nombre de nœuds du réseau sur les performances l'agrégation (taux d'agrégation) a été étudié pour les trois protocoles mentionnés dans la partie de simulation. La figure C.1 montre que le nombre de nœuds agrégés pour le protocole DAP est plus élevé que pour les deux autres protocoles. Il est également évident en se basant sur la figure que le ratio d'agrégation augmente avec le nombre de nœuds du réseau dans le cas du protocole DAP, alors qu'il reste presque constant pour les deux autres solutions. Cela signifie que d'utilisation de DAP est directement proportionnelle aux nœuds de réseau. Au contraire, les deux autres protocoles gardent presque le même comportement quand le nombre de nœuds augmente. En effet, le protocole basé sur l'apprentissage par automates se concentre sur la découverte du plus court chemin, et donc la taille moyenne de chemin ne change pas en avec taille du réseau qui reste donc fixe. Le routage classique a les plus fiables performances puisque l'acheminement des messages est fait indépendant les uns des autres et ne considère pas l'agrégation des données.



**Figure C.1:** Taux d'agrégation pour les trois algorithmes

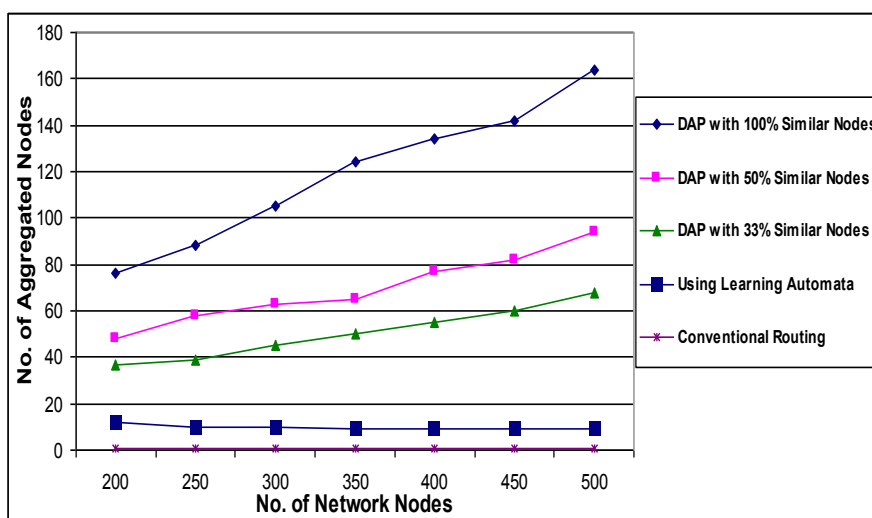
**Expérience 2:** Dans ce scénario, la consommation totale d'énergie de chaque protocole a été calculée pour déterminer le protocole qui fournira le plus d'économie d'énergie en fonction du nombre de nœuds du réseau. La figure C.2 montre que le protocole d'apprentissage par automates réalise la plus faible consommation électrique. Toutefois, afin de parfaire la comparaison entre les trois protocoles, nous devons lier la consommation d'énergie de chaque protocole au nombre de messages de données agrégées. Comme il est montré dans l'expérience 1, le protocole DAP recueille par données à partir d'un nombre de nœuds plus grand que le protocole d'apprentissage des automates en raison de l'agrégation plus élevée. Prenant cela en considération, le protocole DAP permet d'obtenir la meilleure consommation d'énergie parmi les trois protocoles en ce qui concerne les messages de données agrégées. Comme le montre la figure, la consommation totale d'énergie du protocole DAP augmente faiblement en fonction de la taille du réseau. C'est normal puisque le nombre de nœuds voisins augmente dans le réseau dense, d'où le nombre de nœuds dont les données sont agrégées augmente aussi alors que la consommation totale d'énergie des deux autres protocoles augmente énormément dans le réseau dense en raison de la puissance perdue dans les grandes tables de routage.





**Figure C.2:** Consommation d'énergie totale pour chaque algorithme

**Expérience 3:** l'objectif de ce scénario est de comparer le nombre de nœuds agrégés pour les trois protocoles correspondant aux pourcentages de similitudes de données de capteurs (100%, 50% et 33%) puisque les automates d'apprentissage sont basés sur l'agrégation des paquets de nœuds de données similaires. De plus, pour le protocole d'agrégation de données basé sur l'apprentissage par automates, la voie d'agrégation le plus long pour les trois pourcentages supposés a été utilisé pour augmenter le taux d'agrégation de protocoles. Comme le montre la Fig. C.3, DAP permet d'obtenir des performances supérieures par rapport aux autres protocoles, même lorsque le processus d'agrégation se produit entre le 33% des nœuds de réseau.



**Figure C.3:** Comparaison entre les capacités d'agrégation des trois algorithmes pour différents pourcentage le nœuds similaires

### **C.2.2 Nouveau modelé la signalisation pour la santé en environnement NGN**

La recommandation de l'ITU pour les réseaux de capteurs ubiquités (USN) présente les exigences pour une plateforme à plusieurs services [8]. Les USN establishment des collaborations, entre plusieurs nœuds de capteurs sans fil. Ces nœuds sont petits et autonomes capables de mesurer toutes sortes de conditions environnementales et physiques (par exemple, température, bruit, vibration, pression, mouvement ou polluants) et formant la couche de capteurs USN. Les capacités du NGN peuvent influencer sur les exigences de service de l'USN. Les applications et services USN peuvent requérir certaines extensions et/ou des ajouts à base NGN.

Les applications et services USN sont créés par l'intégration des applications et des services de réseau de capteurs dans l'infrastructure. Ils sont appliqués à la vie quotidienne d'une manière invisible car tout est pratiquement lié par la virtualisation des liens entre les utilisateurs finaux USN (y compris les machines et les hommes) et les réseaux de capteurs, relayés par les entités des réseaux intermédiaires tels que les serveurs d'applications, les entités intermédiaires, les entités de réseau d'accès et les passerelles USN.

L'un des principaux marchés émergents pour les applications et services USN est l'e-santé. Il a été conçu pour exploiter la grande capacité des USN à recueillir les données médicales et non médicales des patients pour diverses applications. L'e-Santé offre un accès aux moments opportuns aux derniers progrès de la technologie qui permettent de nouvelles options innovantes pour les patients, les centres médicaux et les hôpitaux pour la gestion des soins aux patients, le contrôle des dossiers électroniques et de nombreuses autres fonctionnalités.

Dans [2], nous avons proposé l'utilisation d'IMS comme sous-couche de contrôle de service dans l'environnement USN. La plateforme IMS est choisie pour utiliser ses avantages et ses caractéristiques [58] et fournir les exigences de service des applications USN [8]. Les principales contributions de [2] sont les suivantes:

- Une conception détaillée du réseau pour la mise en œuvre du service proposé, y compris de nouvelles entités fonctionnelles pour la couche application. Elle est simple, souple et ne nécessite pas de changements compliqués dans les réseaux de communication déjà établis.
- Un flux de signalisation détaillée de réseau pour différents scénarios e-santé applicable en utilisant SIP.

- Une modification du protocole SIP pour correspondre aux caractéristiques prévues dans le service d'e-santé proposé.
- Une détection des cas d'urgence, ce qui est pratiquement indispensable pour sauver la vie des patients.

### C.2.2.1 Projet de réseau et des architecture de services

Le réseau proposé suit l'architecture de réseau NGN-IMS et les exigences de l'USN [8]. Nous avons mis ces exigences sous la forme de dispositifs physiques comme décrit dans le modèle proposé. L'architecture est divisée en cinq couches: la couche des capteurs, celles d'accès, celle de transport, la couche middleware, et celle de service, comme indiqué sur la Fig. C.4.

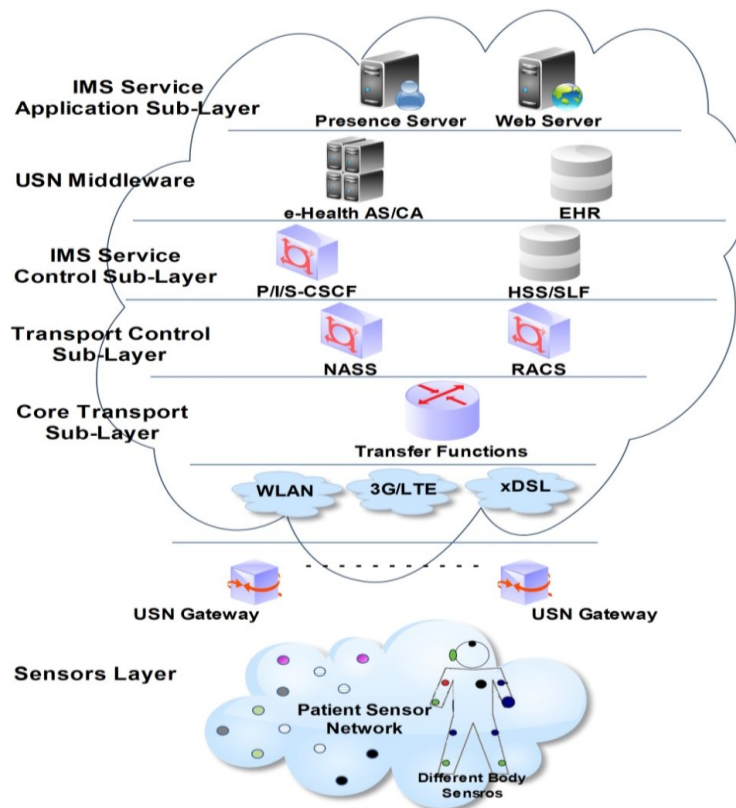


Figure C.4: Prochaine génération d'architecture de réseau d'e-santé

### C.2.2.2 Scénarios de signalisation

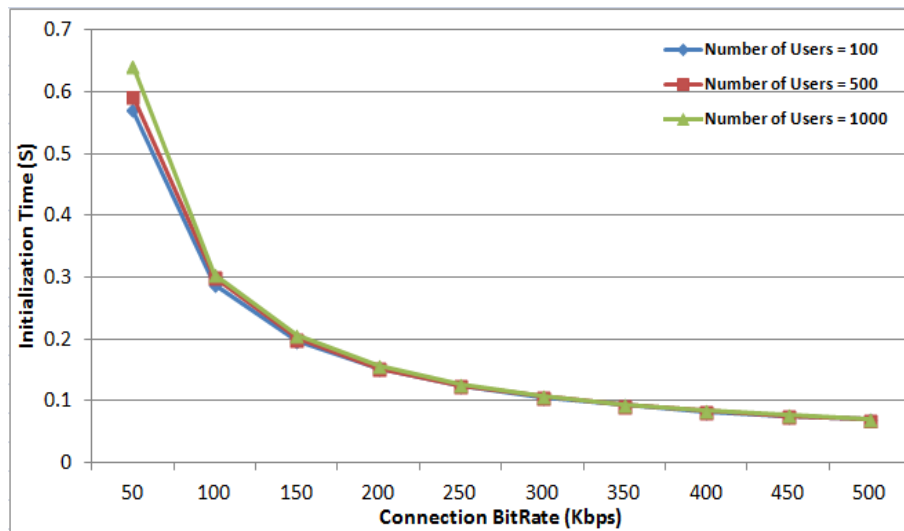
Cette section se concentre sur les fonctionnalités d'IMS et SIP et ne couvre pas la couche transport du NGN puisqu'il n'y a pas de modification de ses fonctions. Nous avons proposé quatre scénarios applicables à l'e-santé avec dans un flux de signalisation

détaillé basé sur le protocole SIP. Les détails de ces scénarios sont mentionnés dans le chapitre quatre.

### C.2.2.3 Évaluation de performances

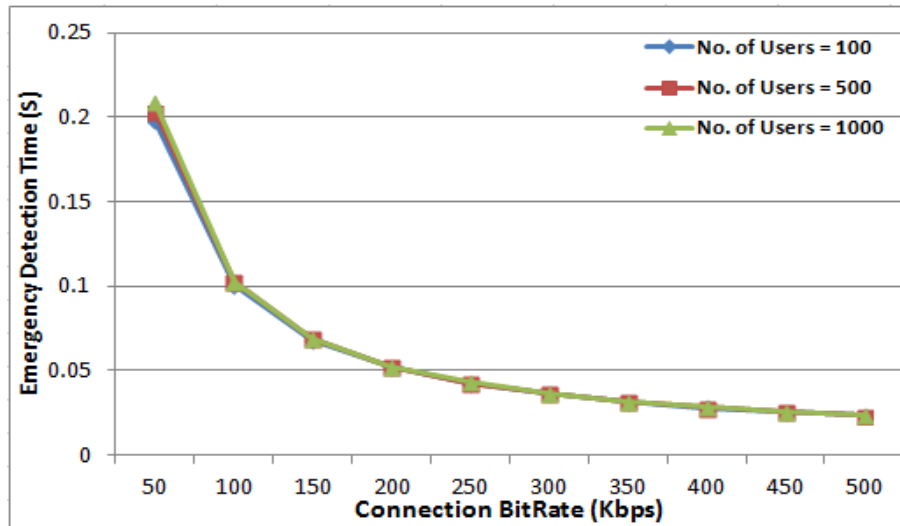
Dans cette partie, nous présentons l'évaluation des performances de notre proposition. Pour l'évaluation du système, nous avons évalué les différents scénarios à l'aide de l'outil de simulation OPNET Modeler 14.0. L'objectif de cette simulation est d'étudier l'applicabilité et la fiabilité des travaux proposés dans différentes conditions de nombres d'utilisateurs et de bandes passantes (BW). Comme notre travail se focalise sur la plate-forme IMS et le protocole de signalisation SIP et que la couche transport NGN n'est pas changée dans notre modèle, notre étude de performance met l'accent sur l'évaluation de l'IMS. Les paramètres IMS (le délai de propagation et le temps de traitement) utilisés dans la simulation sont calculés en fonction de [64].

**Simulation 1:** la première simulation est consacrée au scénario d'initialisation et d'enregistrement. Nous avons étudié l'effet de l'augmentation de la bande passante de la liaison entre la passerelle et le réseau USN sur le temps de service d'initialisation. Le temps d'initialisation est défini comme le temps passé entre le message "Register" de demande (étape 1) et le dernier message envoyé "200 OK" (étape 41) du flux de signalisation de la Fig. 4.3. Nous avons répété plusieurs fois la simulation en augmentant la bande passante de 50 à 500 Kbps par pas de 50 Kbps. Le temps d'initialisation a été calculé pour différents nombres d'utilisateurs variant de 100 à 1000. La Figure C.5 présente les résultats recueillis. La simulation montre que le retard du temps d'initialisation de service décroît avec l'augmentation de la bande passante de connexion. D'un autre côté, le nombre d'utilisateurs a un effet pratiquement négligeable sur le moment de l'initialisation. C'est dû au fait que le débit de connexion nécessaire pour chaque utilisateur pour s'enregistrer et activer son abonnement d'e-santé sur l'IMS est faible avec la signalisation proposée Fig. 4.3. En conclusion, le facteur dominant dans le calcul du temps de service de l'initialisation du flux de signalisation proposée, qui est appliqué sur la plateforme IMS est la bande passante.



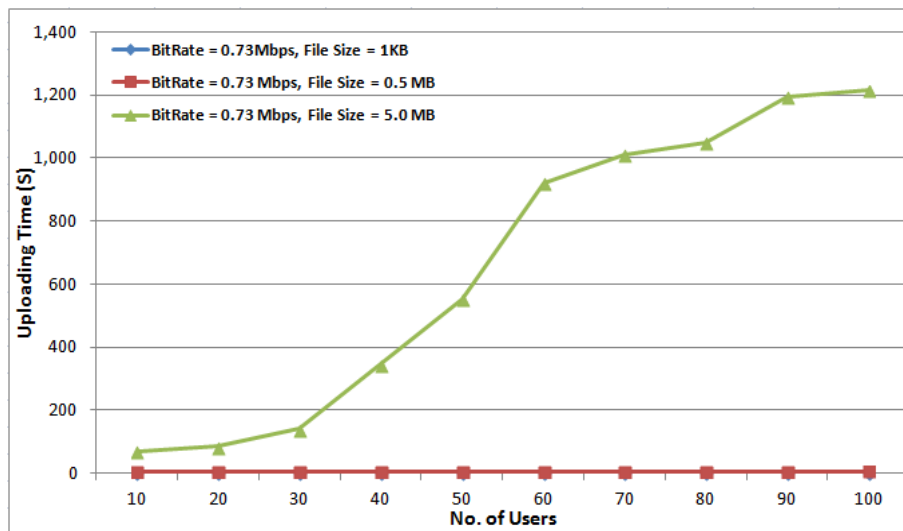
**Figure C.5:** Le temps d'enregistrement à différentes vitesses de connexion

**Simulation 2:** le scénario de détection d'urgence est évalué en simulant le flux de signalisation proposée comme le montre la Fig. 4.5. La simulation a été effectuée pour différentes bandes passantes pour la connexion à la passerelle USN, allant de 50 à 500 Kbps et pour 100, 500 et 1000 utilisateurs. Les résultats recueillis sont représentés Fig. C.6. Le résultat de la simulation montre que le temps maximum de détection d'un cas d'urgence est de 0,21 seconde, ce qui est parfait pour ces situations d'urgence. En outre, le temps de détection décroît de façon exponentielle puisque la bande passante de la connexion aux passerelles USN augmente et elle n'est pas affectée de façon significative par le nombre des utilisateurs. Comme représenté sur la figure, le nombre d'utilisateurs n'a pas un effet important sur le retard. En effet, la bande passante nécessaire pour le processus est faible, ce qui prouve la fiabilité de l'écoulement de la signalisation. En outre, même si la connexion de l'utilisateur est lente et le retard de plus de 0,21 secondes, ce retard reste toujours dans une marge acceptable pour la mise en œuvre du scénario d'urgence, qui permet toujours une notification et une réaction rapide pour les cas d'urgence de santé.



**Figure C.6:** Le temps de détection d'urgence à différentes vitesses de connexion

**Simulation 3:** Afin d'étudier le temps nécessaire pour télécharger le dossier d'un patient vers le serveur de DSE par le WS, nous avons simulé le flux indiqué sur la Fig. 4.7. Nous avons augmenté le nombre d'utilisateurs de 10 à 100 par pas de 10 et la simulation a été répétée pour différentes tailles de fichiers de (1 Ko, 0.5 Mo, 5.0 Mo). La bande passante de la liaison entre la passerelle et le réseau USN a été fixée à 0,73 Mbps correspondant à HSUPA (catégorie 1) du pourcentage de la connexion. La Fig. C.7 présente les résultats obtenus. La figure montre clairement que pour de petites tailles de fichiers de 1 Ko et des taille de fichiers modérées de 0,5 Mo, le retard est presque constant avec l'augmentation du nombre d'utilisateurs. Les tailles des fichiers représentent respectivement l'information détectée par les capteurs, les fichiers d'analyse des patients et la taille moyenne de la radiographie ou des fichiers d'image. Au contraire, pour les grandes tailles de fichiers (5.0 Mo), qui représentent une taille moyenne de fichier vidéo, le retard augmente avec le nombre d'utilisateurs. Par conséquent, la solution proposée est très efficace dans le cas de fichiers petits ou moyens comme des fichiers de données et de radiographie. Mais, les fichiers vidéo vont subir des retards en fonction de leurs tailles. Ainsi, le facteur dominant du retard est la taille du fichier téléchargé.



**Figure C.7:** Temps de téléchargement de fichier pour différents nombres d'utilisateurs

### C.2.3 Modélisation interactive d'applications temps réel dans les VANETs et évaluation de performances

Comme mentionné auparavant, notre principale préoccupation est d'exploiter les avantages de l'USN pour mettre en œuvre des applications de santé. On propose d'intégrer et contrôler ces applications par le réseau IMS en raison de l'évolution rapide de l'ITS, en particulier dans les VANETs, et en raison de l'importance de fournir des applications de sécurité pour la santé. Dans la suite de ce que nous avons développé, un modèle analytique pour la connectivité de lien entre les véhicules sur la route est proposé afin de calculer le nombre de sauts entre un véhicule où un événement « intéressant » a lieu et l'RSU plus proche. Ceci permettra de calculer le temps de transfert entre ces deux nœuds. L'estimation de ce délai est cruciale pour savoir si nous pouvons appliquer des applications en temps réel sur les VANETs et dans quelle mesure.

Nous proposons un modèle pour un nouveau service de sécurité routière de bout-en-bout basée sur l'IMS comme sous couche de contrôle de service pour les VANETs et des équipements portables. Ce modèle proposé est suffisamment général pour être appliqué dans le cadre de n'importe quelle autre application VANET. Le modèle combine les équations analytiques pour le réseau adhoc et le dispositif de commande de service. Etant donné que les applications de sécurité sont sensibles au délai, le temps pris par l'envoi d'une alerte jusqu'à ce qu'une réponse soit reçue est très critique. Ce temps est appelé le temps aller/retour (RTT). Par conséquent, dans ce travail de recherche, nous étudions le RTT qu'il est possible d'avoir des applications de

sécurité sur la base de notre modèle. Cela aidera à calculer instantanément les paramètres tels que le nombre de sauts et le RTT nécessaires pour des applications VANET et nous vérifions aussi l'exactitude du modèle. Les résultats d'analyse provenant des équations sont comparés à des simulations afin de prouver leur validité. À notre connaissance, c'est la première contribution où une telle approche complète est utilisée pour modéliser cette architecture complexe. Les contributions de cet thèse peuvent donc être résumées dans ce qui suit:

- Proposition d'un nouveau modèle complet pour intégrer les plates-formes USN et VANET basés sur l'IMS.
- Développement d'un flux de signalisation complet pour mettre en œuvre l'application de sécurité proposée dans l'IMS en utilisant le protocole SIP.
- Développement d'un modèle de réseau de files d'attente pour les serveurs IMS afin de fournir une estimation complète du délai en fonction du taux d'arrivée d'alertes à l'RSU.
- Calcul du RTT total à partir de l'instant de la transmission d'un message d'alerte d'événement jusqu'à la réception d'une réponse du réseau IMS. Ceci sert à évaluer la fiabilité de l'IMS pour l'utilisation dans la cadre d'applications temps-réel.

### **C.2.3.1 Le modèle de communication VANET**

Nous considérons qu'il existe différents types de véhicules sur la route. Ces véhicules sont équipés d'équipements embarqués qui communiquent les uns avec les autres et avec l'UAR. Les conducteurs utilisent des équipements portables pour surveiller leurs signes vitaux et leur état de santé.

Les messages échangés entre les véhicules ou avec les UAS sont composés d'éléments uniquement déterminés par l'expéditeur ce qui permet un échange de données flexible. Il existe différents types de messages. Le message de sécurité de base contient des informations sur le véhicule lié à la sécurité et sera périodiquement diffusé aux véhicules voisins. Le message d'alerte de véhicule en état d'urgence est utilisé pour la diffusion des avertissements aux véhicules voisins. Le message de sonde de véhicule contient des informations d'état sur le véhicule pour activer les applications qui examinent les conditions de déplacement. Le message voyageur consultatif fournit la congestion, le temps de Voyage, et la signalisation des informations, etc.



Lorsqu'un véhicule détecte un événement, il envoie un message d'alerte aux véhicules voisins afin d'être relayé à l'RSU la plus proche. Ce message contient toutes les données disponibles, y compris l'ID du véhicule, l'emplacement, le voie, la vitesse, etc. Le réseau VANET transmet le message en mode V2V jusqu'à ce qu'il atteigne la RSU la plus proche. Nous utilisons la famille de protocoles WAVE pour cette communication. elle est basée sur le relais directionnel d'informations. Une fois que la RSU est atteinte, on assiste à l'échange du flux de signalisation présenté Fig. C.8.

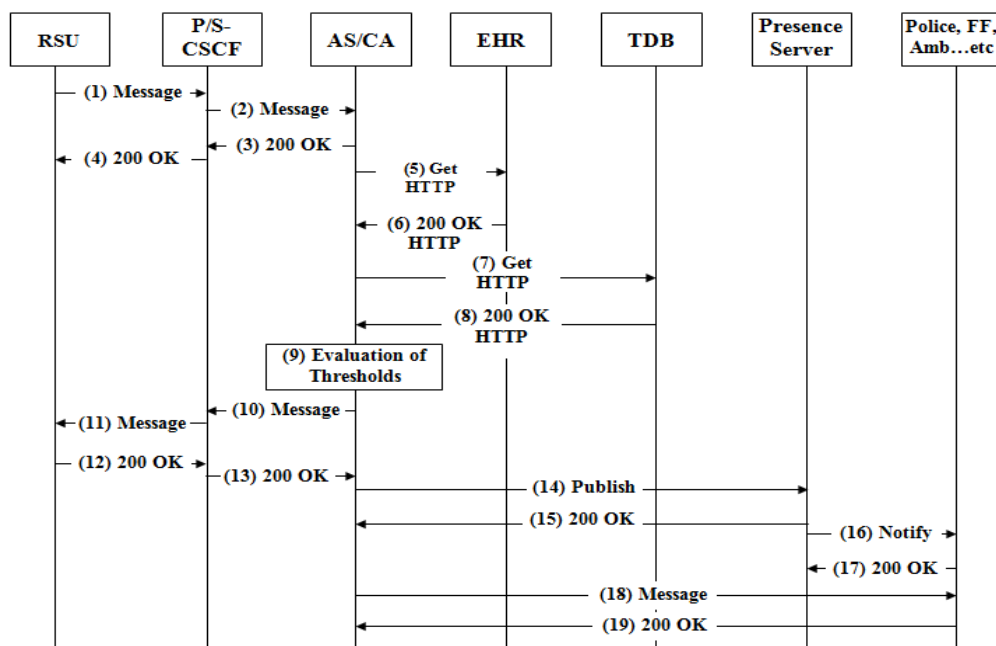


Figure C.8: Flux de signalisation de demande dans l'IMS

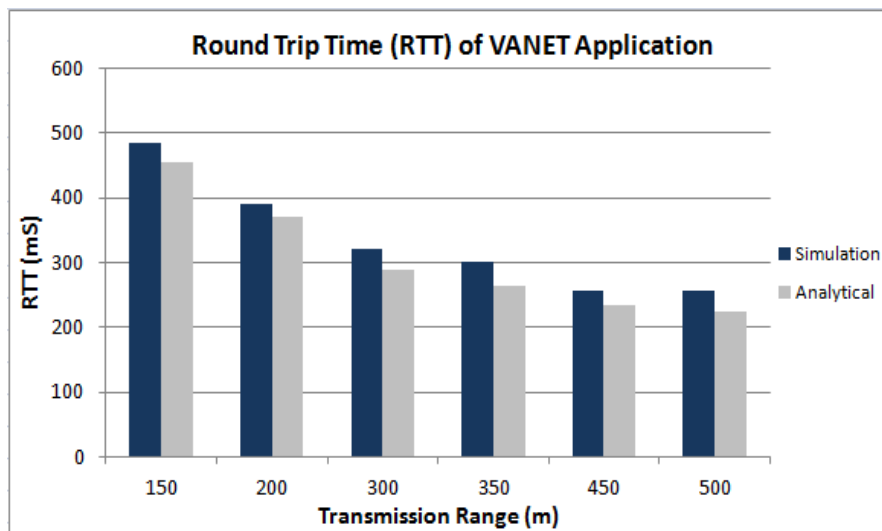
### C.2.3.2 Évaluation de Performances

Dans cette dernière partie, on calcule temps total. Afin d'obtenir ce temps total, nous avons besoin de faire la somme des temps de réponse suivants:

- Temps requis pour envoyer un message d'alerte à partir du véhicule qui détecte l'événement jusqu'à ce qu'il atteigne la RSU la plus proche ;
- Temps nécessaire pour exécuter l'application proposée dans les serveurs IMS et fonction de l'écoulement des messages de signalisation de la Fig. 6.2 ;
- Temps nécessaire pour envoyer le message de réponse IMS aux sites intéressés, et de le diffuser aux véhicules à proximité de l'événement.

À partir de notre modèle VANET, nous avons calculé le temps moyen (analytiquement et par simulation) pris par le message d'alerte pour être envoyé entre

les deux nœuds de distance  $L = 2$ . Pour le réseau IMS, nous avons utilisé le temps moyen de traitement pour l'application VANET proposé dans le tableau 6.2 au chapitre 6. Les Fig. C.9 correspondent à l'inter-distance mentionnée entre le véhicule initiateur de l'événement et la RSU la plus proche. Les chiffres montrent que les résultats d'analyse et de simulation sont proches. Il est évident à partir des résultats sur le RTT que le principal facteur du retard est dû au VANET particulièrement lors de l'utilisation d'une faible couverture de transmission. Comme on peut le voir sur la figure, le RTT est inversement proportionnel à la distance de transmission puisque cela diminue avec l'augmentation de la distance de transmission. Le temps de réponse IMS a un impact plus faible sur le RTT contrairement au délai de communication des véhicules. Le réseau VANET est le principal facteur à prendre en compte dans le calcul du RTT puisque le temps de communication entre les véhicules subit l'effet d'essentiellement trois paramètres que sont la densité des véhicules, les collisions et les éventuelles connexions intermittentes, ce qui donne un retard plus élevé que dans le réseau IMS.



**Figure C.9:** Comparaison du temps aller/retour entre les résultats d'analyse et ceux de simulation pour l'application sur la partie VANET à ( $L = 2\text{km}$ )

### C.3 Conclusion

Dans ce travail, nous détaillons nos trois contributions pour une nouvelle architecture de services divisée en couches. Nous avons proposé l'intégration entre les réseaux USN, VANET et l'IMS (de bas en haut). Pour la couche des capteurs (première contribution), nous avons développé un nouveau protocole d'agrégation dynamique (DAP) qui améliore la diminution du nombre de messages acheminés à la plate-forme

IMS et résout les problèmes prévus sur le réseau de base. De plus, ce protocole d'agrégation de données permet d'atteindre des résultats intéressants en termes de consommation d'énergie pour les réseaux de capteurs. Nous avons comparé le protocole DAP avec deux autres protocoles, un d'agrégation de données basé sur des automates d'apprentissage et un autre basé sur le routage classique. Dans les expériences de simulation, nous avons utilisé des valeurs réelles pour le taux d'échange des capteur, la couverture de transmission et les niveaux de puissance en fonction des conditions d'exploitation typiques des capteurs [39]. En conclusion, d'après les résultats des simulations, le protocole DAP présente des performances supérieures aux deux autres protocoles.

Concernant l'application, nous avons proposé une nouvelle architecture réseau et de nouveaux services suivant l'architecture de réseau NGN-IMS, supportant l'USN et tenant compte les exigences de l'ITU-T [8]. Nous avons proposé de construire l'application e-santé sur l'IMS. C'est en effet un domaine des plus vitaux pour les hommes. Nous avons proposé des scénarios de cas d'urgence avec leurs flux de signalisation SIP détaillée. En outre, nous avons réalisé les modifications nécessaires dans le protocole SIP pour correspondre aux caractéristiques prévues dans le service e-santé. L'évaluation des performances de la solution proposée en utilisant OPNET Modeler prouve sa capacité et son utilité.

Enfin, nous avons proposé un modèle pour un nouveau service de sécurité routière de bout en bout basé sur l'IMS comme service de contrôle de la sous-couche VANET et des équipements portables. Ce modèle est suffisamment général pour être appliqué dans n'importe quelle autre application VANET. Comme les applications de sécurité sont sensibles au délai, nous avons proposé de mesurer le temps moyen aller/retour (RTT) dans ces VANET contrôlés par l'IMS. Pour observer le temps moyen nécessaire, nous avons développé deux nouveaux modèles analytiques. Le premier modélise le lien de connectivité entre les véhicules sur les routes. Le second modélise la fonction de traitement des serveurs IMS afin de fournir une estimation complète du délai en fonction du taux d'arrivée d'alerte à la RSU. Les résultats d'analyse et de simulation pour chaque modèle sont très proches, ce qui prouve la validité des deux modèles. De plus, nous avons prouvé que le RTT est faible et de moins d'une seconde dans la plupart des cas. La majeure partie du RTT est due au temps de communication sur la partie VANET.

## Appendix D: List of Acronyms

<b>3GPP</b>	3rd Generation Partnership Project
<b>AS</b>	Application Server
<b>ASF</b>	Application Server Functions
<b>AUC</b>	AUCthentican Server
<b>BAN</b>	Body Area Network
<b>DAP</b>	Dynamic Aggregation Protocol
<b>BCMP</b>	Baskett, Chandy, Muntz and Palacios
<b>BER</b>	Bit Error Rate
<b>BGCF</b>	Breakout Gateway Control Function
<b>BPSK</b>	Binary Phase Shift Keying
<b>BS</b>	Base Station
<b>BW</b>	BandWidth
<b>CA</b>	Context Awareness
<b>CCA</b>	Clear Channel Assessment
<b>CCM</b>	Car Control Mode
<b>CSCF</b>	Call Session Control Functions
<b>CSMA/CA</b>	Carrier Sense Multiple Access/Collision Avoidance
<b>DNS</b>	Domain Name Server
<b>DSCP</b>	Differentiated Services field Code Point
<b>DSRC</b>	Dedicated Short Range Communication
<b>DSSS</b>	Direct Sequence Spread Spectrum
<b>DTMF</b>	Dual Tone Multi-Frequency
<b>EADT</b>	Energy-Aware Distributed heuristic
<b>ED</b>	Energy Detection
<b>ETSI</b>	European Telecommunication Standards
<b>EHR</b>	Electronic Health Record
<b>FCC</b>	Federal Communications Commission

---

<b>FCFS</b>	First Come First Served
<b>FGNGN</b>	Focus Group of NGN
<b>FMC</b>	Fixed Mobile Convergence
<b>FTP</b>	File Transfer Protocol
<b>GPRS</b>	General Packet Radio Service
<b>GPS</b>	Global Positioning System
<b>GSM</b>	Global System for Mobile communications (Groupe Spécial Mobile)
<b>GTS</b>	Guaranteed Time Slot
<b>HEED</b>	Hybrid Energy-Efficient Distributed clustering
<b>HLR</b>	Home Location Register
<b>HSDPA</b>	High Speed Downlink Packet Access
<b>HSS</b>	Home Subscriber Server
<b>HSUPA</b>	High Speed Uplink Packet Access
<b>HTTP</b>	Hyper Text Transfer Protocol
<b>I-CSCF</b>	Interrogating CSCF
<b>IBCF</b>	Interconnection Boarder Control Function
<b>IEEE</b>	Institute of Electrical and Electronics Engineers
<b>IFC</b>	Initial Filter Criteria
<b>IMS</b>	IP Multimedia Subsystem
<b>IP</b>	Internet Protocol
<b>IP-CAN</b>	IP Connectivity Access Network
<b>IPTV</b>	Internet Protocol TeleVision
<b>ISDN</b>	Integrated Service Digital Network
<b>ISM</b>	Scientific and Medical
<b>ISUP</b>	Integrated Service Digital Network User Part
<b>ITS</b>	Intelligent Transport Systems
<b>ITU</b>	International Telecommunication Union
<b>ITU-T</b>	ITU- Telecommunication Standardization Sector
<b>IWF</b>	Inter-Working Function

---

<b>LEACH</b>	Low-Energy Adaptive Clustering Hierarchy
<b>LCFS</b>	Last Come First Served
<b>LQI</b>	Link Quality Indication
<b>LTE</b>	Long Term Evolution
<b>MAC</b>	Medium Access Control
<b>MANET</b>	Mobile Ad-hoc NETWORK
<b>MC</b>	Medical Center
<b>MEMS</b>	Micro Electro-Mechanical Systems
<b>MIME</b>	Multipurpose Internet Mail Extensions
<b>MGCF</b>	Media Gateway Control Function
<b>MGW</b>	Media Gateway
<b>MPDU</b>	MAC Protocol Data Units
<b>MRFC</b>	Media Resource Function Controller
<b>MRFP</b>	Media Resource Function Processor
<b>NACF</b>	Network Attachment Control Functions
<b>NAPT</b>	Network Address and Port Translation
<b>NASS</b>	Network Attachment Subsystem
<b>NGN</b>	Next Generation Network
<b>NGN-GSI</b>	NGN-Global Standards Initiative
<b>OBU</b>	On Board Unit
<b>OMA</b>	Open Mobile Alliance
<b>OQPSK</b>	Offset-Quadrature Phase Shift Keying
<b>OSA</b>	Open Services Architecture
<b>P-CSCF</b>	Proxy CSCF
<b>PCN</b>	Public Communication Network
<b>PDA</b>	Personal Digital Assistance
<b>PEGASIS</b>	Power-Efficient Gathering in Sensor Information Systems
<b>PHY</b>	Physical
<b>POTS</b>	Plain Ordinary Telephone System
<b>PPDU</b>	PHY Protocol Data Unit

---

<b>PS</b>	Presence Server
<b>PSTN</b>	Public Switched Telephone Network
<b>QoS</b>	Qualify of Service
<b>RACF</b>	Resource and Admission Control Functions
<b>RACS</b>	Admission Control Subsystem
<b>RSU</b>	Road Side Unit
<b>RTT</b>	Round Trip Time
<b>Rx</b>	Receiving
<b>S-CSCF</b>	Service CSCF
<b>SDP</b>	Session Description Protocol
<b>SLF</b>	Subscription Locator Function
<b>SIP</b>	Session Initiation Protocol
<b>SMS</b>	Short Message Service
<b>SN</b>	Sensor Network
<b>TCC</b>	Traffic Control Center
<b>TCP</b>	Transmission Control Protocol
<b>TDB</b>	Traffic Data Base server
<b>TISPAN</b>	Telecommunications and Internet converged Services and Protocols for Advanced Networking
<b>ToIP</b>	Telephony over IP
<b>TREEPSI</b>	TRee based Energy Efficient Protocol for Sensor Information
<b>Tx</b>	Transmission
<b>UDP</b>	User Datagram Protocol
<b>UE</b>	User Equipment
<b>UMTS</b>	Universal Mobile Telecommunications System
<b>UPSF</b>	User Profile Server Function
<b>USB</b>	Universal Serial Bus
<b>USN</b>	Ubiquitous Sensor Network
<b>V2I</b>	Vehicular to Infrastructure
<b>V2V</b>	Vehicular to Vehicular

---

<b>VANET</b>	Vehicular Ad-hoc NETwork
<b>WAVE</b>	Wireless Access in Vehicular Environments
<b>WCDMA</b>	Wideband Code Division Multiple Access
<b>WLAN</b>	Wireless Local Area Network
<b>WPAN</b>	Wireless Personal Area Network
<b>WS</b>	Web Server
<b>xDSL</b>	Digital Subscriber Line