



HAL
open science

Improving performance on NUMA systems

Baptiste Lepers

► **To cite this version:**

Baptiste Lepers. Improving performance on NUMA systems. Performance [cs.PF]. Université de Grenoble, 2014. English. NNT : 2014GRENM005 . tel-01549294

HAL Id: tel-01549294

<https://theses.hal.science/tel-01549294>

Submitted on 28 Jun 2017

HAL is a multi-disciplinary open access archive for the deposit and dissemination of scientific research documents, whether they are published or not. The documents may come from teaching and research institutions in France or abroad, or from public or private research centers.

L'archive ouverte pluridisciplinaire **HAL**, est destinée au dépôt et à la diffusion de documents scientifiques de niveau recherche, publiés ou non, émanant des établissements d'enseignement et de recherche français ou étrangers, des laboratoires publics ou privés.

THÈSE

Pour obtenir le grade de

DOCTEUR DE L'UNIVERSITÉ DE GRENOBLE

Spécialité : **Informatique**

Arrêté ministériel : 7 août 2006

Présentée par

Baptiste Lepers

Thèse dirigée par **Vivien Quéma**
et co-encadrée par **Renaud Lachaize**

préparée au sein du **LIG**
et de **L'École Doctorale Mathématiques, Sciences et Technologies de l'Information, Informatique**

Amélioration de performance sur les architectures NUMA

Improving performance on NUMA systems

Thèse soutenue publiquement le **24/01/2014**,
devant le jury composé de :

Prof. Pascal Felber
Université de Neuchâtel, Rapporteur

Dr. Erven Rohou
Inria, Rapporteur

Prof. Andrzej Duda
Grenoble INP, Examineur

Dr. Gilles Muller
Inria, Examineur

Dr. Gaël Thomas
UPMC, Examineur

Prof. Vivien Quéma
INP Grenoble, Directeur de thèse

Dr. Renaud Lachaize
UJF, Co-Encadrant de thèse



Abstract

Modern multicore systems are based on a Non-Uniform Memory Access (NUMA) design. In a NUMA system, cores are grouped in a set of *nodes*. Each node has a memory controller and is interconnected with other nodes using high speed interconnect links. Efficiently exploiting such architectures is notoriously complex for programmers. Two key objectives on NUMA multicore machines are to limit as much as possible the number of remote memory accesses (i.e., accesses from a node to another node) and to avoid contention on memory controllers and interconnect links. These objectives can be achieved by implementing application-level optimizations or by implementing application-agnostic heuristics. However, in many cases, existing profilers do not provide enough information to help programmers implement application-level optimizations and existing application-agnostic heuristics fail to address contention issues. The contributions of this thesis are twofold. First we present MemProf, a profiler that allows programmers to choose and implement efficient application-level optimizations for NUMA systems. MemProf builds temporal flows of interactions between threads and objects, which help programmers understand why and which memory objects are accessed remotely. We evaluate MemProf on Linux on three different machines. We show how MemProf helps us choose and implement efficient optimizations, unlike existing profilers. These optimizations provide significant performance gains (up to 2.6x), while requiring very lightweight modifications (10 lines of code or less). Then we present Carrefour, an application-agnostic memory management algorithm. Contrarily to existing heuristics, Carrefour focuses on traffic contention on memory controllers and interconnect links. Carrefour provides significant performance gains (up to 3.3x) and always performs better than existing heuristics.

Keywords. NUMA, multicore, memory contention, profiling, memory management, traffic management, remote memory accesses, locality.

Résumé

Les machines multicœurs actuelles utilisent une architecture à Accès Mémoire Non-Uniforme (Non-Uniform Memory Access - NUMA). Dans ces machines, les cœurs sont regroupés en *nœuds*. Chaque nœud possède son propre contrôleur mémoire et est relié aux autres nœuds via des liens d'interconnexion. Utiliser ces architectures à leur pleine capacité est difficile : il faut notamment veiller à éviter les accès distants (i.e., les accès d'un nœud vers un autre nœud) et la congestion sur les bus mémoire et les liens d'interconnexion. L'optimisation de performance sur une machine NUMA peut se faire de deux manières : en implantant des optimisations ad-hoc au sein des applications ou de manière automatique en utilisant des heuristiques. Cependant, les outils existants fournissent trop peu d'informations pour pouvoir implanter efficacement des optimisations et les heuristiques existantes ne permettent pas d'éviter les problèmes de congestion. Cette thèse résout ces deux problèmes. Dans un premier temps nous présentons MemProf, le premier outil d'analyse permettant d'implanter efficacement des optimisations NUMA au sein d'applications. Pour ce faire, MemProf construit des flots d'interactions entre threads et objets. Nous évaluons MemProf sur 3 machines NUMA et montrons que les optimisations trouvées grâce à MemProf permettent d'obtenir des gains de performance significatifs (jusqu'à 2.6x) et sont très simples à implanter (moins de 10 lignes de code). Dans un second temps, nous présentons Carrefour, un algorithme de gestion de la mémoire pour machines NUMA. Contrairement aux heuristiques existantes, Carrefour se concentre sur la réduction de la congestion sur les machines NUMA. Carrefour permet d'obtenir des gains de performance significatifs (jusqu'à 3.3x) et est toujours plus performant que les heuristiques existantes.

Mots-clés. NUMA, multicœurs, congestion mémoire, analyse, profiling, gestion mémoire, gestion du trafic, accès mémoire distant, localité.

Acknowledgments

I would like to thank the members of my PhD committee, Professor Pascal Felber, Doctor Erven Rohou, Professor Andrzej Duda, Doctor Gilles Muller and Doctor Gaël Thomas for their precious time and valuable suggestions for the work done in this dissertation.

A special thanks to Vivien Quéma and Renaud Lachaize for supervising this thesis, it has been a real pleasure to work with them. Thanks for the long hours and weekends spent on articles and for pushing me to strive for excellence during these last years.

A big thanks to all the people I have collaborated with: Fabien Gaud, Alexandra Fedorova and the whole team at SFU. I would also like to thank Gilles Muller for his help during the early days of multicore in the Sardes team and Gaël Thomas for the great discussions we had on our works.

I would also like to thank the whole Erods team and the previous Sardes team. A special thank goes to all people I closely worked with, most of which became friends. Thanks to the B218 Team – Fabien Gaud, Fabien Mottet and Sylvain Genevès – for sparking my interest in multicore machines, for all the hikes and the stupid YouTube videos. Thanks to Pierre-Louis Aublin for being such a good sport about our jokes on his work and on Chinese girls. Thanks to Gautier Berthou for his great mood and for all the great climbing sessions. Thanks to Jérémie Decouchant for the hiking sessions and for all the work we have done together. Thanks to Amadou, Soguy, Alain and Ahmed for the African food and for their great mood. And thanks to Michael Lienhardt for sparking my interest in cycling.

Finally, a special thanks to my whole family without whom this thesis would not have been possible. Thanks for the advices and for being supportive through these years.

Preface

The thesis presents the research conducted in the in the Sardes team (INRIA Grenoble – Rhône-Alpes / Laboratoire d’Informatique de Grenoble) and Eroads (Laboratoire d’Informatique de Grenoble) to pursue the Ph.D. in the specialty “Informatics” from the Doctoral School “Mathématiques, Sciences et Technologies de l’Information, Informatique” of the Université de Grenoble.

The research activities have been supervised by Vivien Quéma (Eroads/Grenoble INP) and Renaud Lachaize (Eroads/UJF). Some of the works presented in this thesis were done as an international research collaboration with the systems group at SFU in Vancouver, Canada [1].

This thesis focuses on improving the performance of multicore applications on NUMA systems. The contributions of this thesis are twofold: (i) a memory profiler designed to help developers find and implement efficient optimizations on NUMA systems and (ii) a dynamic memory management algorithm that automatically mitigate contention on NUMA systems.

This thesis led to two publications in two international conferences:

- **MemProf: A Memory Profiler for NUMA Multicore Systems.** Renaud Lachaize, Baptiste Lepers, and Vivien Quéma. *In Proceedings of the USENIX Annual Technical Conference (USENIX ATC), Boston, USA, June 2012* [2]
- **Traffic Management: A Holistic Approach to Memory Placement on NUMA Systems.** Mohammad Dashti, Alexandra Fedorova, Justin Funston, Fabien Gaud, Renaud Lachaize, Baptiste Lepers, Vivien Quéma, and Mark Roth. *In Proceedings of the International Conference on Architectural Support for Programming Languages and Operating Systems (ASPLOS), Houston, USA, March 2013* [3]

Contents

Abstract	i
Résumé	ii
Acknowledgments	iii
Preface	v
Table of contents	vii
Introduction	1
1 From UMA to NUMA multicore machines	3
1.1 Memory management in a multicore machine	4
1.1.1 Virtual memory	4
1.1.2 Fetching data	5
1.1.2.1 Caches	5
1.1.2.2 Inter-core communication	7
1.1.2.3 Cache coherency	8
1.1.3 Prefetching unit	9
1.2 Uniform Memory Access architectures (UMA)	10
1.2.1 Organization of UMA machines	10
1.2.2 Limitations of UMA	10
1.3 Non Uniform Memory Access architectures (NUMA)	11
1.3.1 Organization of NUMA machines	11
1.3.2 History of NUMA machines	11
1.4 Characteristics of the NUMA multicore machines used in the evaluations	12
1.4.1 Machine A - 16 cores, 4 nodes, HT1 links	12
1.4.2 Machine B - 24 cores, 4 nodes, HT3 links	14
1.4.3 Machine C - 48 cores, 8 nodes, HT3 links	14
1.5 Challenges introduced by NUMA	14
1.5.1 Remote access penalty	14
1.5.2 Contention on interconnects and memory buses	15
1.5.3 Remote accesses versus contention	16
1.5.4 Differences with the NUMA machines used in the 80s	16
1.6 Classic optimizations on NUMA multicore machines	16

1.6.1	Memory allocation	17
1.6.2	Memory migration	17
1.6.3	Memory interleaving	18
1.6.4	Memory replication	18
1.6.5	Thread Placement	18
1.6.6	Difficulty to choose and implement an optimization	18
1.7	Future architectures	19
1.7.1	Large scale NUMA systems	19
1.7.2	Possible evolutions of memory	20
1.7.3	Possible evolutions of multicore processors	21
1.7.4	GPGPU and accelerators	21
1.8	Conclusion	22
2	Contributions	23
2.1	MemProf	23
2.2	Carrefour	24

I MemProf - Profiling memory accesses on NUMA multicore machines

25

3	Existing profiling techniques	27
3.1	Hardware profiling facilities	28
3.1.1	Hardware counters	28
3.1.1.1	Description	28
3.1.1.2	Format of Hardware Counters on AMD processors	29
3.1.1.3	Undocumented bugs on AMD processors	30
3.1.2	Instruction Based Sampling (IBS)	31
3.1.2.1	Description	31
3.1.2.2	Overhead of IBS	31
3.1.2.3	Difference between HWC and IBS	32
3.1.3	Precise Event Based Sampling (PEBS)	32
3.1.4	Lightweight profiling (LWP)	33
3.1.5	Hardware breakpoints	33
3.2	Software profiling facilities	34
3.2.1	Tracing	34
3.2.2	System Monitors	35
3.2.3	Cycle accurate simulators	36
3.2.4	Accessed bit	36
3.3	Determining the impact of memory on an application	36
3.3.1	Impact of the speed of memory accesses	37
3.3.2	Is an application accessing memory locally?	38
3.3.3	Is an application creating contention?	38
3.4	Existing profilers	40
3.5	Limitations of existing profilers	42
3.6	Conclusion	43

4	MemProf: a memory profiler for NUMA multicore machines	45
4.1	Overview	45
4.2	Timelines of thread-object access patterns	46
4.3	Implementation	47
4.3.1	Event collection	47
4.3.2	TEF and OEF construction	49
4.4	Example usage	50
4.5	Conclusion	52
5	Evaluation	53
5.1	FaceRec	53
5.2	Streamcluster	55
5.3	Psearchy	57
5.4	Apache/PHP	58
5.5	Overhead	60
5.6	Conclusion	61
II	Carrefour - Dynamic memory management on NUMA multicore machines	63
6	Motivation	65
6.1	MemProf vs. dynamic memory management algorithms, advantages and constraints of live diagnosis	66
6.2	Existing static and dynamic memory algorithms	67
6.2.1	Works done on UMA systems	67
6.2.2	Linux - “First touch” and “interleave” allocation policies	67
6.2.3	Solaris and Windows - Home node	68
6.2.4	AutoNUMA	68
6.2.5	Verghese et al. - ASPLOS’96	68
6.2.6	DINO	69
6.2.7	Thread Clustering	70
6.2.8	Affinity Accept	70
6.3	Limitations of existing dynamic memory management algorithms	70
6.4	Conclusion	71
7	Carrefour	73
7.1	Overview	74
7.2	Profiling	75
7.2.1	Global and per application metrics	75
7.2.2	Capturing interactions between threads and pages	76
7.3	Per application decisions	77
7.4	Per page decisions	78
7.5	Reducing the overhead	78
7.5.1	Reducing the overhead of capturing interactions between threads and pages	78
7.5.2	Avoiding bad per page decisions	80

7.6	Conclusion	80
8	Evaluation	83
8.1	Single-application workloads	83
8.1.1	Performance comparison	83
8.1.2	Performance analysis	84
8.1.3	Limitations of Carrefour: the IS.D use case	88
8.2	Overhead	88
8.3	Conclusion	89
	Conclusion	91
	Bibliography	93
	List of figures	99
	List of tables	101
	Appendix	103
A	Performance analysis of Carrefour on machine A	103
B	Performance analysis of Carrefour on machine B	107

Introduction

Context

Modern multicore systems are based on a Non-Uniform Memory Access (NUMA) architecture. In a NUMA system, cores are grouped in a set of *nodes*. Each node has a memory controller and is interconnected with other nodes using high speed interconnect links. For instance, Figure 1 pictures a 4-node NUMA system with 4 cores per node.

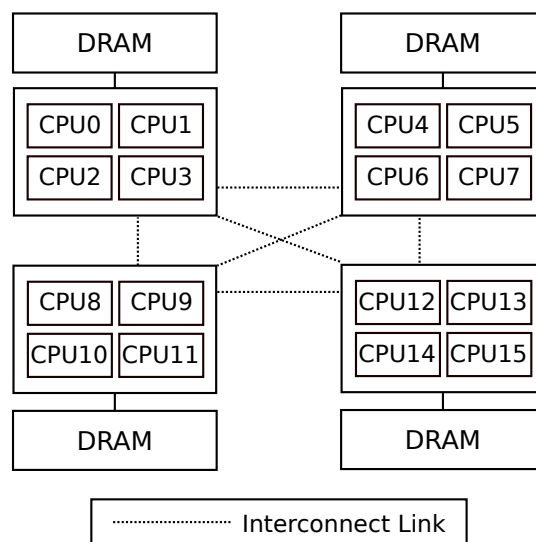

Figure 1 – A NUMA system with 4 nodes and 4 cores per node.

Efficiently exploiting such architectures is notoriously complex for programmers. One of the key concerns is to limit as much as possible the number of remote memory accesses and to avoid contention on memory controllers and interconnect links. Remote memory accesses happen when a core accesses a memory controller that is not directly attached to it. Contention occurs when multiple threads access the same memory controller or use the same interconnect link and exceed its maximum bandwidth.

Multiple techniques have been developed to avoid these issues. The basic technique consists in introducing application-level optimizations through lightweight modifications of the application's source code. For example, a programmer can improve the placement of threads and objects by, among other optimizations, modifying the choice of the allocation pool, pinning a thread on a node, or duplicating an object on several

memory nodes. Yet, it is generally difficult to determine which optimizations apply to a given application and implementing them requires a precise knowledge of the interactions between threads and objects, i.e., knowing which threads access which objects remotely. Currently no tool is able to provide this information.

Other techniques have been proposed to avoid NUMA issues. Most of these techniques try to improve thread placement or memory placement automatically [4, 5, 6, 7, 8, 9, 10]. Yet, none of these techniques addresses contention issues on NUMA machines (i.e., they only focus on limiting the number of remote memory accesses).

Contributions

In this context, our contributions are as follows:

- We implement and evaluate a NUMA profiler called MemProf. MemProf allows developers to detect the causes of the remote memory accesses and to introduce simple optimizations within complex and unfamiliar code bases. MemProf achieves this result by building temporal flows of interactions between threads and objects allocated by any application.
- We implement and evaluate a dynamic memory placement algorithm called Carrefour. Previous NUMA-aware memory placement algorithms focused on limiting the number of remote memory accesses. Carrefour takes a new approach and focuses on limiting contention on memory controllers and interconnect links.

Organization of the document

The thesis is organized as follows: Chapter 1 explains why machines switched from Uniform Memory Access architectures (UMA) to Non-Uniform Memory Access architectures (NUMA), and presents the challenges introduced by NUMA. Chapter 2 motivates the two contributions of this thesis. Then, Chapters 3, 4 and 5 focus on profiling. More precisely, Chapter 3 presents existing profiling tools and explains why they are not sufficient to understand NUMA-issues. Chapter 4 presents the first contribution of this thesis, MemProf, and Chapter 5 evaluates it. The last three Chapters of this thesis focus on dynamic memory placement algorithms. Chapter 6 motivates the need for a new memory placement algorithm. Chapter 7 presents the second contribution of this thesis, Carrefour, and Chapter 8 evaluates it. After this last Chapter, we conclude this thesis with perspectives for future works.



From UMA to NUMA multicore machines

Contents

1.1	Memory management in a multicore machine	4
1.1.1	Virtual memory	4
1.1.2	Fetching data	5
1.1.2.1	Caches	5
1.1.2.2	Inter-core communication	7
1.1.2.3	Cache coherency	8
1.1.3	Prefetching unit	9
1.2	Uniform Memory Access architectures (UMA)	10
1.2.1	Organization of UMA machines	10
1.2.2	Limitations of UMA	10
1.3	Non Uniform Memory Access architectures (NUMA)	11
1.3.1	Organization of NUMA machines	11
1.3.2	History of NUMA machines	11
1.4	Characteristics of the NUMA multicore machines used in the evaluations	12
1.4.1	Machine A - 16 cores, 4 nodes, HT1 links	12
1.4.2	Machine B - 24 cores, 4 nodes, HT3 links	14
1.4.3	Machine C - 48 cores, 8 nodes, HT3 links	14
1.5	Challenges introduced by NUMA	14
1.5.1	Remote access penalty	14
1.5.2	Contention on interconnects and memory buses	15
1.5.3	Remote accesses versus contention	16
1.5.4	Differences with the NUMA machines used in the 80s	16
1.6	Classic optimizations on NUMA multicore machines	16
1.6.1	Memory allocation	17
1.6.2	Memory migration	17

1.6.3	Memory interleaving	18
1.6.4	Memory replication	18
1.6.5	Thread Placement	18
1.6.6	Difficulty to choose and implement an optimization	18
1.7	Future architectures	19
1.7.1	Large scale NUMA systems	19
1.7.2	Possible evolutions of memory	20
1.7.3	Possible evolutions of multicore processors	21
1.7.4	GPGPU and accelerators	21
1.8	Conclusion	22

In this chapter, we explain why machines evolved from a Uniform Memory Access (UMA) architecture, in which all cores access all memory regions with the same latency, to a Non Uniform Memory Access (NUMA) architecture, in which cores access different memory regions with different latencies. This chapter is divided in 8 sections. First we explain how memory is managed in a multicore machine by the operating system and by the hardware. Second, we describe UMA multicore machines and explain their limitations. Third, we describe NUMA machines and their advantages over UMA machines. Fourth, we present the NUMA machines used in the evaluation Section of this thesis. Then, we explain challenges introduced by NUMA and the techniques used to address these challenges. We conclude this chapter with an overview of the possible evolutions of NUMA architectures and discuss how works done for NUMA architectures could still apply on these new architectures.

1.1 Memory management in a multicore machine

We first describe the virtual memory mechanism, and show how it allows the operating system to share physical memory between applications. Then we explain how the hardware handles virtual memory addresses provided by the operating system and how it fetches data from main memory. We explain how the hardware tries to minimize the latencies of memory accesses using caches and prefetchers.

1.1.1 Virtual memory

Current multicore machines often run multiple applications at the same time. These applications store their data in memory and have to share the physical addressable space without overwriting each other's data. Virtual memory allows applications to manipulate memory as if they were the only application running on the system. The operating system is in charge of maintaining the mapping between virtual memory addresses manipulated by the applications and physical addresses used by the hardware. When an application requests memory, the operating system returns a contiguous virtual address space. This virtual address space is not necessarily contiguous in physical address space (as illustrated in Figure 1.1).

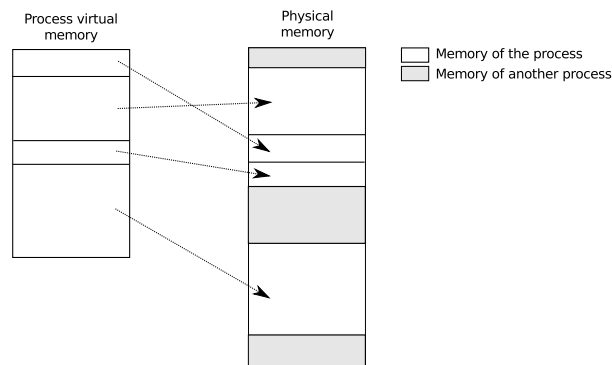

Figure 1.1 – Physical to virtual memory mapping. The operating system is in charge of maintaining the mapping between virtual memory regions and physical memory.

The operating system manages virtual memory allocations and destructions at the granularity of a “page”. A page represents a span of contiguous virtual and physical address space (usually 4KB). The kernel stores mappings between pages’ virtual addresses and pages’ physical addresses in a page table. Currently most processors do the translation between virtual and physical addresses in hardware and require the operating system to store the page table using a predefined layout. Figure 1.2 pictures the layout of the page table used in x86_64 machines. On x86_64 machines, the page table is a 4-level translation table. Each entry in the first 3 translation levels points to a translation table of the next level. Entries of the 4th level contain physical address spaces. To perform the translation, the hardware splits virtual addresses in five bit ranges. The first 4 ranges are used as indexes in the 4 levels of the page table. The last range is the address offset in the physical page. The hardware has to perform the virtual to physical address translation for all memory access. To speed up the translation process, recent translations are cached in a special buffer named Translation Lookaside Buffer (TLB).

1.1.2 Fetching data

1.1.2.1 Caches

Arithmetic units of current processors perform operations on registers. The total amount of data that can be stored in registers is very small (less than a kilobyte on current processors), so processors often load data to and flush data from registers. Accessing the main memory directly is slow: between 100 and 2000 cycles on modern hardware (in comparison, arithmetic units are able to perform up to 4 operations on registers in a cycle). To minimize accesses to the main memory, processors use caches that are accessed with a much lower latency (between 3 and 60 cycles on modern hardware). Maximizing the cache-hit rate is an important part of improving performance on multicore hardware. It has been extensively studied in the literature [7, 11, 12, 13, 14].

Modern multicore processors usually have 3 levels of cache, as pictured in fig 1.3. Caches cache data at the granularity of a cache line (usually 64B). Each transfer between levels of caches or between caches and DRAM is done in 64B chunks.

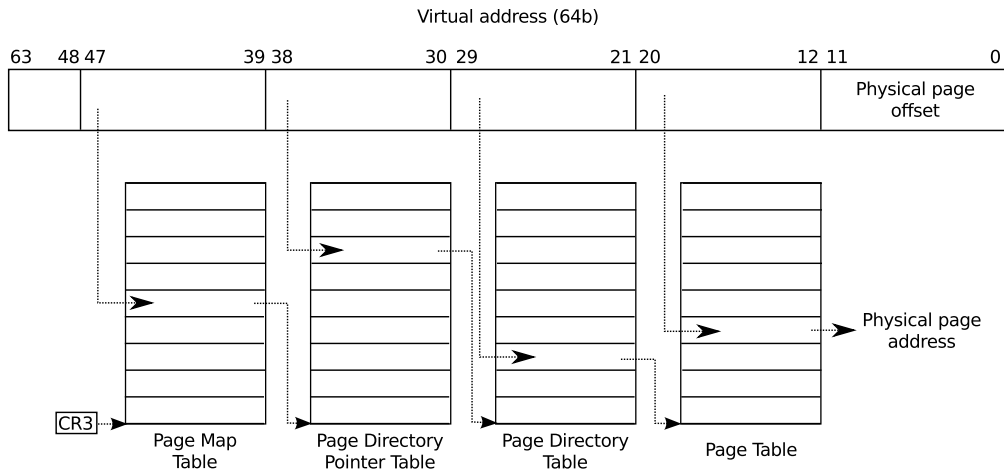

Figure 1.2 – Page table format. The operating system segments the addressable space in “pages”. The mapping between virtual addresses of pages and their physical address is stored in a page table. On current x86_64 systems, the page table has to be a 4-level hierarchical translation table.

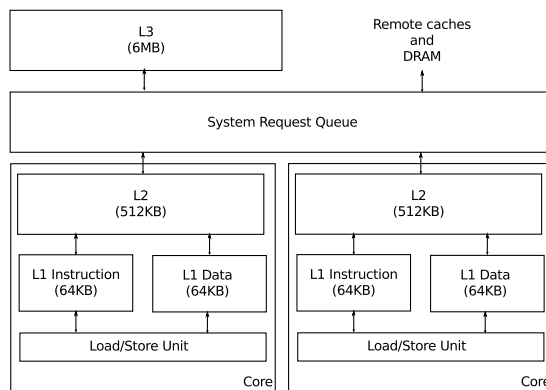

Figure 1.3 – Caches. Modern multicore processors often have multiple levels of cache. The latency required to access a data in cache is much lower than that of accessing data in DRAM.

The first level of cache, called L1, is a small cache (usually 32KB or 64KB) that is accessed with a low latency (3 or 4 cycles). To speed up lookups in the L1, L1 caches are often virtually indexed and physically tagged. The processor initiates the lookup in the L1 cache using the virtual address of the load or of the store before the virtual address has been translated to a physical address. This way, the translation of the virtual address and the lookup in the cache can be parallelized. When the processor finds a cache line that matches the requested virtual address, it waits for the virtual to physical translation to complete and checks that the physical address tag of the cache line matches the requested physical address. Despite its small size, because applications tend to have a high spatial and temporal locality, the L1 cache often has a high hit rate (often more than 98%).

If the requested data is not present in the L1 cache, the processor looks for it in the L2 and L3 caches. L2 and L3 caches are bigger than L1 caches (between 512KB and 12MB) and are accessed with a higher latency. Typical latencies are: 12 cycles for L2 and 60 cycles for L3. If the requested data is not present in the caches, the core will send a request to get the data from other cores' caches or from the DRAM.

1.1.2.2 Inter-core communication

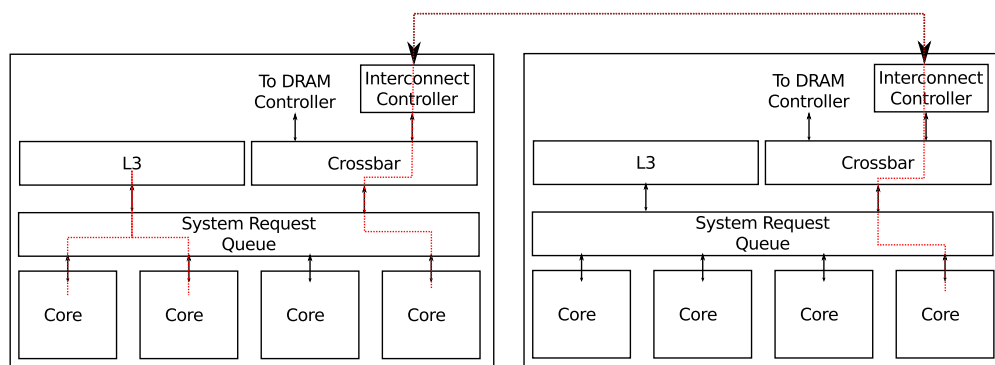

Figure 1.4 – Inter-core communications. When two cores share a cache (e.g., a L3), they communicate via this cache. Otherwise, they communicate using interconnect links.

When a core wants to get data from another core's cache, it has to communicate with it. There are two main ways for cores to communicate, as pictured in Figure 1.4. When two cores are located in the same processor, they communicate either (i) via their common shared L3 or (ii) by sending requests to the other cores' L2 and L1. When two cores are located on different processors, they use interconnect links.

The interconnect links technology varies between processors models. For example, AMD machines use the Hypertransport (HT) technology and Intel processors use the QuickPath Interconnect (QPI) technology. Both technologies are “packet-based”: data that transits via HT or QPI links are split in multiple packets of fixed size. Each packet contains a header that indicates the source and the destination of the packet (similarly to IP packets). When all processors are not directly interconnected, packets can be routed and forwarded by processors to reach their destination. Table 1.1 presents the main

characteristics of HT and QPI technologies. The Hypertransport technology is more general purpose and can be adapted depending on the constraints of the environment it is deployed in. Current AMD processors use a mix of 8 and 16-bit HT links. Each processor has between 4 and 6 HT links. These links are both used to interconnect processors and to connect processors and I/O. QPI is less general purpose (it was specifically developed to interconnect Intel processors between themselves and I/O). Despite differences in their implementations, we measured on our machines that both technologies are currently configured to achieve approximately the same maximal bandwidth (6.6GB/s for HT links vs. 6.8GB/s for QPI links).

	Hypertransport	QuickPath Interconnect
Packet Size	N*32 bits (depends on the packet type)	80 bits (64 useful bits)
Link width	2 to 32 bits	20 bits
Maximum bandwidth	6.4GB/s (HT1) 25.6GB/s (HT3)	12.8GB/s
Observed bandwidth on our machines	2.8GB/s (HT1) 3GB/s to 6.6GB/s (HT3)	6.8GB/s
Latency of a link	24ns (~50 cycles @2.1GHz)	21ns (~50 cycles @2.4Ghz)

Table 1.1 – Comparison between Hypertransport (AMD) and QuickPath Interconnect (Intel) technologies. The difference between the maximum bandwidth supported by the specification and the observed bandwidth is due to links not using the maximum width (e.g., current AMD processors use 8 or 16 bit links) or not working at their maximum frequency.

1.1.2.3 Cache coherency

When cores communicate to get data, they do not “steal” data from each other’s caches: the same data can be cached in multiple places at the same time. To maintain coherence between all caches, the current processors rely on the MOESI protocol. The objective of this protocol is to prevent processors to read outdated versions of data that were modified by other processors. The MOESI protocol defines 5 possible cache line states:

- **M - Modified.** The cache line contains the last version of the data and the last version is present only in this cache line. The value in main memory is incorrect (thus the value will have to be written in main memory when the cache line is flushed).
- **O - Owned.** The cache line contains the last version of the data and this last version is also present in other processors’ caches. The value in main memory is incorrect. For a given data, only one cache line can be in the owned state; other cache lines containing the same data have to be in the “Shared” state. Only the “owner” of a cache line writes the last version of the data in memory when the cache line is flushed.

-
- E - Exclusive. The cache line contains the last version of the data and the data is not present in any other cache. The main memory also contains the last value. The cache line does not need to be written in main memory when flushed.
 - S - Shared. The cache line contains the last version of the data. The last version of the data may also be in another processor cache. If all cache lines containing this data are shared, the main memory is up to date. Otherwise the cache line is “owned” by another cache, which will be responsible for writing the value to memory. In all cases, when flushed, the cache line does not need to be written in main memory.
 - I - Invalid. The cache line contains an outdated version of the data.

When a processor writes a value in a cache line, it invalidates cache lines containing the same data in other processors’ caches. Messages exchanged to maintain cache coherency can consume a significant portion of the available interconnect bandwidth. For example, on a 4-node machine with 16 cores, we measured that the cache coherency protocol can represent up to 15% of the traffic of interconnect links.

Recent processors have been optimized to reduce the number of cache coherency messages. HT Assist, available in AMD processors since the release of the Istanbul family, is an example of such an optimization. HT Assist uses a part of the L3 as a directory cache. The directory cache of a node keeps track of all cache lines that use data coming from this node in the system. In a system using HT Assist, cache coherency messages are sent only to the caches that actually contain a copy of the data and are not broadcast to all caches [15].

1.1.3 Prefetching unit

Processors try to maximize the cache-hit ratio in order to reduce memory access latencies. To this purpose, they try to predict which data will be used in the near future to put them in the processor caches before they are requested. Prefetchers perform this job. Prefetchers are entirely implemented in hardware, and the operating system has very little control over their operations. On most processors, it is only possible to disable prefetchers and/or to control the degree of “confidence”¹ required to prefetch data.

Current processors include multiple prefetchers that use different heuristics to prefetch memory. For example, Opteron processors include 2 levels of prefetchers: one per core and one per processor. Prefetchers work best when an application has regular memory access patterns (called “stride patterns”: scanning an array, copying memory, etc.) but are also able to prefetch complex memory access patterns (e.g., pointers indirections used in object oriented programming). Current prefetchers rarely degrade performance and can provide significant performance gains (for most applications, activating the prefetcher results in a 5 to 15% increase in performance) [16].

¹The meaning of “confidence” and its impact on the operations of the prefetcher is not clearly defined in the processors’ documentations.

1.2 Uniform Memory Access architectures (UMA)

1.2.1 Organization of UMA machines

Processors can be interconnected to the DRAM in multiple ways. The simplest design consists in having a single memory controller to which all processors address their memory requests. Using this design, all processors access all memory regions with the same latency. This design is thus named Uniform Memory Access (UMA). Figure 1.5 pictures a typical UMA machine with two 4-core processors. Both processors share a bus to the DRAM.

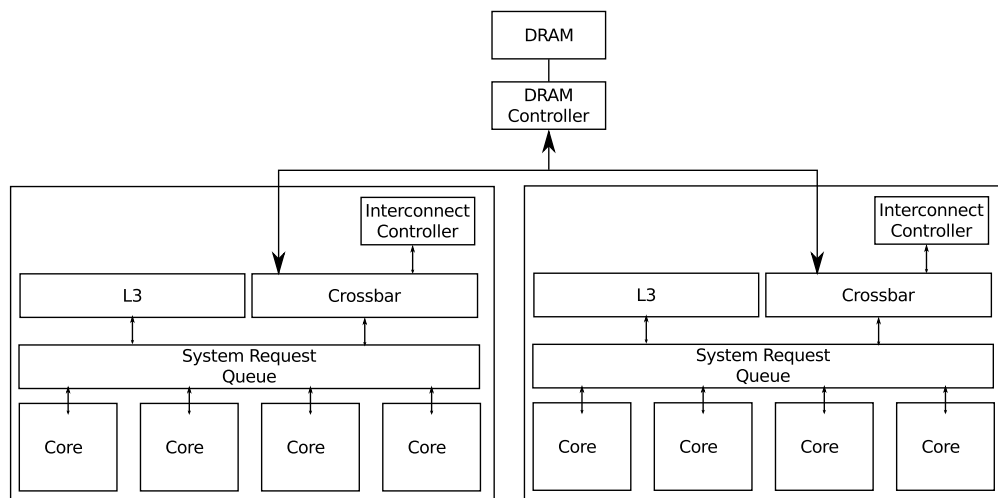

Figure 1.5 – UMA. All processors share a single DRAM controller.

1.2.2 Limitations of UMA

In UMA machines, the bandwidth to the memory is limited by the bandwidth of a single memory controller. Historically, the peak bandwidth of memory controllers has grown much slower than the number of instructions per cycles that processors can execute: since 1980, on average memory speed has increased by 10% per year while processor speed has increased by 55% per year.

Current memory controllers can achieve a peak bandwidth of 17GB/s using DDR3 clocked at 266Mhz. This peak bandwidth is, in practice, not sufficient in many contexts. If a processor sends more memory requests per second than the memory controller can sustain, these requests are queued. As queues grow, so does the latency of memory accesses. As seen in the previous sections, processors have tried to mask latencies of memory accesses (e.g., using caches and prefetchers), but as the latency continues to increase, it becomes more and more difficult to mask the costs of memory accesses. This problem is known as the “memory wall” and has been extensively documented [17, 18, 19].

1.3 Non Uniform Memory Access architectures (NUMA)

1.3.1 Organization of NUMA machines

The goal of NUMA architectures is to increase the available bandwidth to the DRAM. The key idea behind NUMA architectures is to have multiple memory controllers. Cores in the machine are grouped into “nodes”; each node has its own memory controller. Figure 1.6 pictures a NUMA machine with 8 cores grouped into 2 nodes. In a NUMA machine, a core accesses memory controlled by the memory controller of its node (“local memory”) directly. To access memory controlled by other memory controllers (“remote memory”), the core has to send memory requests via the interconnect links. This indirection, required to access remote memory, means that a core accesses memory of its controller with a lower latency than that of other nodes. Because the latency depends on the location of the memory accesses, this architecture is called “Non Uniform” Memory Accesses (NUMA).

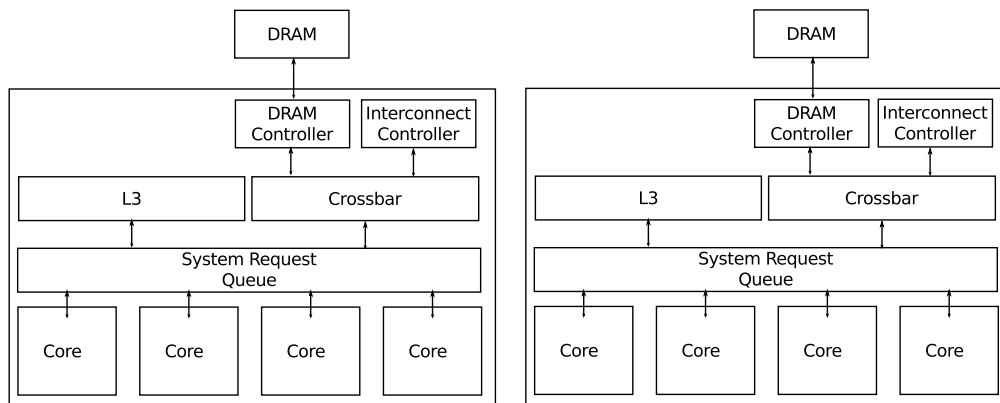

Figure 1.6 – NUMA. Cores are grouped into “nodes”. Each node has a DRAM controller.

The maximum available bandwidth of a NUMA machine is the sum of the peak bandwidth of each memory controller. On modern NUMA machines that only send cache coherency messages when required, the maximum bandwidth can be achieved when all cores access their local node. When all cores access their local node, no cache coherency message is sent and the interconnect links are not used - thus avoiding latencies or bandwidth limitations due to inter-node communications.

1.3.2 History of NUMA machines

One of the first successful commercial NUMA machines was the Honeywell Bull XPS-100 released in the late 80’s. It could host between 2MB and 16MB of RAM that were split in multiple memory banks. On such systems, the cost of a remote access was 13 times the cost of a local memory access (115 cycles vs. 9 cycles [20]).

NUMA machines in the early 90’s were mainly used in mainframes. NUMA only appeared in personal computers in 2003 with the AMD Opteron family. Intel introduced NUMA with the Nehalem family in 2007. Currently most processors produced for the computer industry are based on a NUMA architecture. Processors used in embedded

systems (e.g., smartphones) still mostly use UMA architectures, but will likely switch to a NUMA architecture in the years to come [21].

1.4 Characteristics of the NUMA multicore machines used in the evaluations

In this thesis, we evaluated NUMA effects and optimizations on 3 different machines. This section provides a detailed analysis of observable NUMA effects on these machines. Table 1.2 summarizes the main characteristics of the 3 machines and Figure 1.7 presents the topology of the 3 machines.

	Machine A	Machine B	Machine C
Processor Family	Opteron 8380	Opteron 6164	Opteron 6174
Processor Speed	2.5GHz	1.7GHz	2.2GHz
Number of NUMA nodes	4	4	8
Local Memory Access Latency (cycles)	261	175	151
Remote Memory Access Latency (cycles)	286 (1 hop) 377 (2 hops)	247	232 (1 hop) 337 (2 hops)
Memory controller bandwidth	7580MB/s	5850MB/s	6080MB/s
Interconnect technology	HT1 No HT Assist	HT3 HT Assist	HT3 HT Assist
Interconnect bandwidth	2850MB/s (16-bit link)	4810MB/s (16-bit link)	4590MB/s (16-bit link)
		2100MB/s (8-bit link)	3830MB/s (16-bit link, 8 bits used)
			2550MB/s (8-bit link)

Table 1.2 – Main characteristics of the machines used in the evaluations.

1.4.1 Machine A - 16 cores, 4 nodes, HT1 links

Machine A has 4 AMD Opteron 8380 processors clocked at 2.5GHz with 4 cores in each (16 cores in total) and 32GB of RAM. It features 4 memory nodes (each node contains 4 cores and 8GB of RAM) interconnected with Hypertransport 1.0 links. Table 1.2 summarizes the main characteristics of machine A. Machine A has the highest local memory bandwidth of the three machines, but a low interconnect bandwidth. Three cores are required to saturate their local memory controller. One core can saturate an interconnect link. Because machine A does not use HT Assist, cache coherency messages represent a significant portion of interconnect traffic (up to 15% on the studied

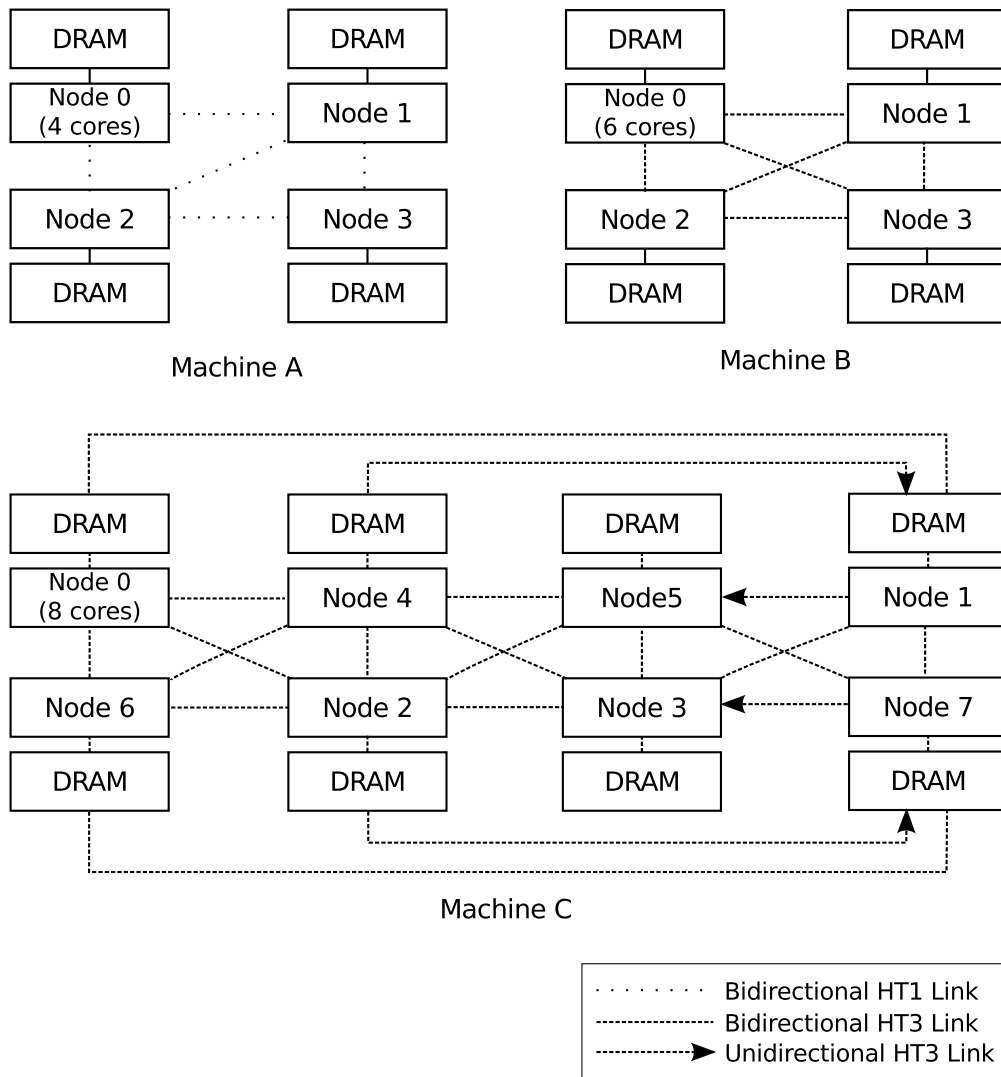

Figure 1.7 – Topology of the machines used in the evaluations. Some links in machine C are unidirectional.

applications). As pictured in Figure 1.7, nodes are partially connected (there is no direct interconnect link between node 0 and node 3).

1.4.2 Machine B - 24 cores, 4 nodes, HT3 links

Machine B has 2 AMD Opteron 6164 HE processors clocked at 1.7 GHz with 12 cores in each (24 cores in total) and 48 GB of RAM. It features 4 memory nodes (i.e., 6 cores and 12 GB of RAM per node) interconnected with Hypertransport 3.0 links. Machine B has a low memory bandwidth, only 20% greater than interconnect links bandwidth (see Table 1.2). One core is sufficient to saturate a local memory controller or an interconnect link. As pictured in Figure 1.7, nodes are fully interconnected. Note that the link between node 0 and 3 is an 8-bit link and that other links are 16-bit wide. Experimentally, we measured that the bandwidth between node 0 and node 3 is 56% smaller than that of other interconnect links.

1.4.3 Machine C - 48 cores, 8 nodes, HT3 links

Machine C has 4 AMD Opteron 6174 processors clocked at 2.2 GHz with 12 cores in each (48 cores in total) and 256 GB of RAM. It features 8 memory nodes (i.e., 6 cores and 32 GB of RAM per node) interconnected with Hypertransport 3.0 links. As for Machine B, Machine C use both 8-bit and 16-bit HT links; the bandwidth between nodes varies from 2.5GB/s to 4.5GB/s (see Table 1.2). As pictured in Figure 1.7, nodes are partially interconnected. The interconnect topology of Machine C is complex and some links are unidirectional (e.g., sending data from node 3 to node 7 requires 2 hops while sending data from node 7 to node 3 requires only 1 hop). One core is sufficient to saturate a memory controller or an interconnect link.

1.5 Challenges introduced by NUMA

To maximize the usage of a NUMA machine, a developer has to minimize the number of remote memory accesses and to make sure that the load is balanced between memory controllers [5, 22, 23, 24, 25, 26, 27, 28]. In this section, we show on a set of applications the impact of remote memory accesses and of memory controller contention on performance. We use applications taken from the Parsec Benchmark suite [29], from the NAS Benchmark suite [30], from the Metis Benchmark suite [31] and two microbenchmarks (*RandomRead* and *SequentialRead*) that perform random reads to the memory and sequential read to the memory respectively.

1.5.1 Remote access penalty

To measure the impact of remote accesses on performance, we run applications on a node and force all of their memory to be either allocated on the local node or on a remote node. We then compare the two execution times to measure the impact of remote memory accesses on performance. To avoid contention effects on interconnect links and memory buses, we run applications with only one thread. We verified experimentally that applications were not saturating any interconnect link or memory bus.

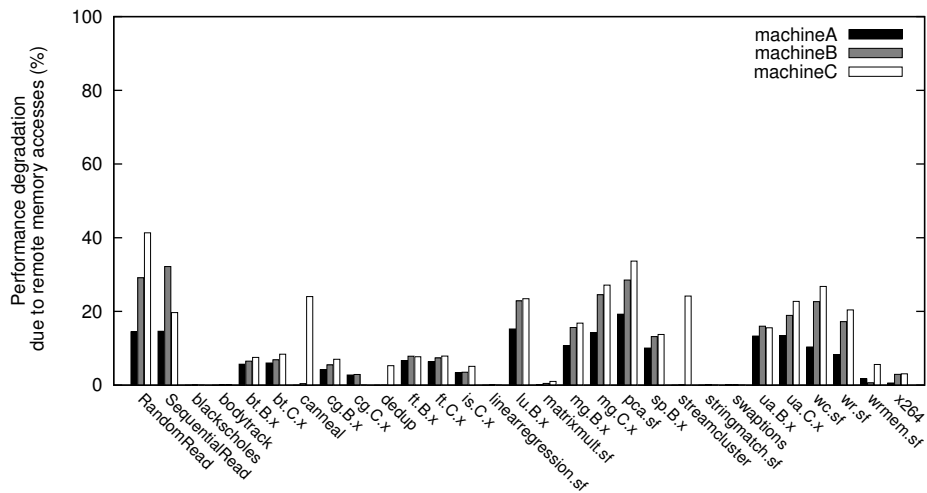

Figure 1.8 – Impact of remote memory accesses on performance of various applications.

Figure 1.8 shows the impact of remote memory accesses on performance on the three machines presented in the previous section. Remote accesses penalty is on average 10%, with a maximum of 40%.

1.5.2 Contention on interconnects and memory buses

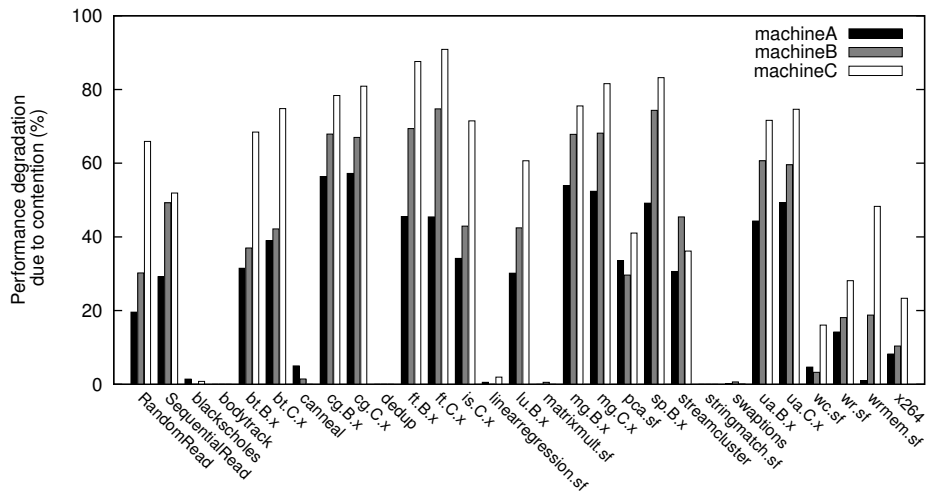

Figure 1.9 – Impact of contention on performance of various applications.

To measure the impact of contention on performance, we run applications with as many threads as the number of cores in the system. We compare the execution time of each application in two configurations: (i) all memory allocated on a single node and (ii) memory randomly placed and balanced between all nodes. The goal of this setup is

to compare an experiment that puts the maximum possible contention on memory buses (experiment i) with an experiment that puts the lowest possible contention on memory buses (experiment ii). Note that the local access ratio between these two experiments is theoretically the same, so performance differences are only due to the difference in contention on memory nodes. Indeed, in a system with N nodes, in case (i), 1 node accesses memory locally and $N-1$ nodes access memory remotely; if all nodes perform approximately the same number of memory accesses, the local access ratio is $1/N$. In case (ii), when a thread performs a memory access, it has $1/N$ chance to perform a local memory access (memory is randomly placed on all nodes).

Figure 1.9 shows the impact of contention on performance on the three machines presented in the previous section. Contention penalty is on average 40%, with a maximum of 90%.

1.5.3 Remote accesses versus contention

As Figures 1.8 and 1.9 show, on current hardware, contention on interconnects and memory buses has a higher impact than remote memory accesses. This is not a surprise considering the specifications of the studied machines: interconnect links and memory buses have a low latency and a low bandwidth. Consequently, the impact of a remote memory access is constant and “low”, while bandwidth of interconnects and buses can easily be exceeded and create long waiting queues. For example, on machine B, the cost of a remote memory access is constant (+72 cycles, 40% of the cost of a local memory access) and 1 core can saturate a memory bus – so, when 24 cores are accessing a memory bus at the same time, their bandwidth is divided by up to 24.

1.5.4 Differences with the NUMA machines used in the 80s

The main difference between current NUMA machines and NUMA machines built in the 80-90’s is memory access latencies, and especially the difference between the cost of a local access and a remote access. As we have seen in Section 1.3.2, the cost of a remote memory access used to be 13 times the cost of a local access. On current hardware, the cost of a remote memory access is less than 1.4 times that of a local access, on all applications that we tested. Consequently, the impact of remote memory accesses is less visible on current machines than it was in the 90’s.

On current machines, the main problem comes from contention. Contention could also occur in the machines used in the 90’s, but it was not a major performance issue: if contention occurred, it meant that the machine was doing remote memory accesses and that the performance was already very low.

1.6 Classic optimizations on NUMA multicore machines

Multiple optimizations exist to avoid remote memory accesses and contention on memory controllers. In this section we present the 5 main techniques used to optimize applications on NUMA architectures. These techniques work on thread and memory placement. For each technique, we explain how it can be used to optimize applications on NUMA architectures and briefly describe some ways to implement it. For each technique, we give insights on the situations in which the technique does and does

not apply. We conclude this section with a discussion on the difficulty to choose and implement the best optimization.

1.6.1 Memory allocation

The simplest NUMA optimization consists in allocating data on the node from which it will be the most accessed. This optimization works best when thread placement is known in advance and memory accesses to allocated data are predictable. Memory allocation is a static optimization: once a data has been allocated on a node, it stays on the node. Memory allocation is unlikely to work well when threads migrate between nodes or when data is accessed from multiple nodes.

The default allocation policy varies depending on the allocation library and the operating system. For example, on Linux with the `libc` allocator, data is allocated on the node from which it is first accessed. This heuristic guarantees that, if a thread allocates data and continues to use it on the same node, then data will be accessed locally. To force memory to be allocated on a node, a developer can use the `numa_alloc_onnode` function, provided by the `libnuma` library. This function takes two arguments: the size to allocate and the node on which to allocate the data.

Memory allocation works well on applications designed according to the *no-sharing principle*. The key idea behind no-sharing is that data must be partitioned. When a thread wants to access data located on a remote domain, it asks a thread located on the remote domain to perform the work [32, 33, 34, 35, 36, 37, 38]. The *no-sharing principle* eases the process of determining the “best” memory location for a given data, because each data can only be accessed from one node. Note that the *no-sharing principle* is challenging to implement because it requires a strict partition of functionalities and data in the application. It is thus currently only used in a few applications.

1.6.2 Memory migration

Memory migration consists in migrating data on the node from which they are the most accessed. Memory migration is a dynamic technique: the same data can be migrated multiple times depending on the workload. Because migrating data from node to node has a cost, memory migration works best on data that are accessed from a single node during long periods of time. Memory migration is unlikely to work well on data that are frequently accessed from different nodes.

Memory migration can be implemented in two ways: (i) by allocating a buffer of memory on a specific node and copying the data in this buffer; this technique requires updating all existing references to the data to point to the newly allocated buffer, or (ii) by using system calls to migrate pages from a node to another node; this technique is transparent from the application point of view (virtual addresses are unmodified) but only works at the granularity of pages. To allocate a buffer on a specific node, a developer can use the `numa_alloc_onnode` function. To migrate pages, a developer can use the `sys_migrate_pages` system call.

1.6.3 Memory interleaving

Memory interleaving consists in spreading memory randomly on multiple memory controllers. Contrarily to other optimization techniques, memory interleaving does not aim at improving memory locality but only at reducing memory controller contention. Memory interleaving can be applied statically - by placing data randomly on nodes during allocation - or dynamically - by periodically migrating memory to balance load between memory controllers. Interleaving memory works best when a memory controller is saturated. Because it can reduce locality, it often does not work on applications that have a high memory access locality.

The OS can perform memory interleaving automatically. The `numactl` tool can be used to this purpose. It is also possible to interleave memory of specific data using the `numa_alloc_interleaved` function.

1.6.4 Memory replication

Memory replication consists in replicating data on multiple nodes and making sure that threads access the replica located on their local node. When applicable, memory replication provides optimal locality. Replication has an initial cost - the creation of the replicas - and additional costs every time replicated data is written - because changes must be propagated to all replicas. Consequently, replication works best on data that are accessed read-mostly from multiple nodes.

Current unmodified operating systems do not support page replication. On an unmodified kernel, a developer has to implement memory replication by hand. The simplest way to implement replication is to allocate a replica on every node using the `numa_alloc_onnode` function and protecting accesses to the allocated data using reader/writer locks. Replication can be applied either statically by assigning a specific replica to each thread or dynamically by choosing the correct replica every time a memory access to the data is performed. To choose the correct replica dynamically, a developer might rely on the `getcpu` system call to get the CPU and NUMA node on which a thread is currently running.

1.6.5 Thread Placement

Thread placement consists in trying to place threads close to the data they are accessing. Migrating a thread is costly and has many undesirable side effects (e.g., data that were in cache have to be fetched again from memory). Thread migration also has to be carefully controlled to avoid creating imbalance on CPUs (e.g., overloading a CPU while leaving another CPU idle). So thread placement works best when threads can be balanced on all cores close to their memory for long periods of time.

Threads can be pinned on a specific CPU or node using the `sched_setaffinity` function.

1.6.6 Difficulty to choose and implement an optimization

Table 1.3 presents 5 memory access patterns and shows, for each memory access pattern, the optimizations that make and do not make sense. We can see that no optimization makes sense in all cases presented in the table. When faced with a NUMA

problem, a developer thus has to choose between optimizations. In order to choose between these optimizations a developer has at least to know which data are accessed remotely or are creating contention, if these data are accessed from multiple nodes at the same time and if they are often modified. By looking at an application code, it is not possible to know which data will be accessed remotely because applications rarely control the placement of their threads and memory. It is also often impossible to know if multiple threads access a data simultaneously: timing is notoriously hard to understand in parallel applications. So, in the general case it is not possible to know, just by looking at an application code, which optimization to choose. In chapter 3, we explain why existing profilers do not provide enough information to choose between optimizations.

	Alloc.	Migr.	Inter.	Repl.	Thread Plac.
Memory is accessed from 1 node	✓	✓			✓
Memory is accessed from multiple nodes at different time intervals		✓	✓	✓	✓
Memory is accessed from multiple nodes at the same time			✓	✓	
Memory is often modified	✓	✓	✓		✓
Memory is accessed with a high locality	✓	✓		✓	✓

Table 1.3 – Non-exhaustive list of workloads (lines) and NUMA optimizations (columns). A tick means that the NUMA optimization may make sense for the given workload.

1.7 Future architectures

Current multicore machines are NUMA. In this section we give insights on possible evolutions of NUMA machines. We first explain how NUMA machines may evolve as the number of NUMA nodes increase. Then we overview possible evolutions of memory and processors and explain how works done for classical NUMA machines could still apply on these new architectures.

1.7.1 Large scale NUMA systems

The current trend in multicore NUMA systems is to increase the number of cores and the number of NUMA nodes. As the number of NUMA nodes increases, the interconnect topology between these NUMA nodes is likely to change. For example, a NUMA system with 512 nodes is unlikely to be fully interconnected (a full mesh would require more than 260K interconnect links). The current solution used to build large NUMA system (e.g., in super computers) is to use a fat-tree architecture. Figure 1.10 represents a 2-level fat-tree architecture. In fat-tree architectures, NUMA nodes are clustered into super nodes; all nodes in a “super node” are interconnected via a router. Super nodes are interconnected using high bandwidth interconnect links. On very large-scale systems, like the Altix 512p, “super nodes” may even be clustered into

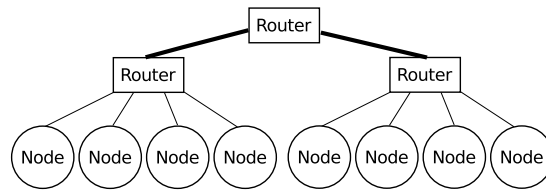

Figure 1.10 – Fat tree architecture. NUMA nodes are interconnected via multiples routers. Routers can be interconnected using high bandwidth interconnect links.

“super node groups”, creating another hierarchy level. The advantage of fat-tree designs is that high bandwidth links, that are costly and may have a high power consumption, are only used for interconnect links that are the most likely to be used (links on “top” of the fat-tree hierarchy).

Challenges in fat-tree based systems are similar to that of classical NUMA systems. Memory accesses are still non-uniform and contention may occur on the interconnect links of the bottom of the fat tree hierarchy or on memory controllers (e.g., if all nodes access memory located on a single node). Fat-tree architectures also offer additional challenges, compared to classical NUMA-based systems because of the interconnect hierarchy between nodes. It is for example possible to do optimizations at the level of a “super node” or at the level of “groups of super nodes” that would not make sense in NUMA systems with a full mesh interconnect.

1.7.2 Possible evolutions of memory

As seen in section 1.3, memory speed has been growing more slowly than processors speed for 20 years. Currently, the most promising approach to improve memory speed comes from the Hybrid Memory Cube Consortium (HMCC) [39]. The key idea behind the Hybrid Memory Cube is to stack multiple DRAM-dies in 3D. DRAM dies are interconnected via a logic die that is in charge of routing requests between DRAM dies. The peak bandwidth of interconnect links is 15Gb/s according to the specification and current prototypes use 10Gb/s links. Current prototypes stack a maximum of 16 DRAM-dies, adding up to a maximum bandwidth of 160Gbs (20GB/s). To put this figure in perspective, current DDR3 modules clocked at 266Mhz have a maximum bandwidth of 17GB/s.

HMC is a promising approach to improve the bandwidth to the memory. According to the specification, the maximum bandwidth of HMC could be up to 15 times the bandwidth of a standard DDR3 module. That said, we believe that this improvement is not sufficient to bring back UMA architectures. Indeed, current servers are built with 8 NUMA nodes, thus already achieving a peak bandwidth of 8 times the peak bandwidth of DDR3. A single DRAM module that has a maximum bandwidth of 15 times DDR3 peak bandwidth is unlikely to be sufficient - even in the near future.

HMC could bring disparities in memory access latencies in the same memory chip. Indeed, a HMC is composed of multiple DRAM dies that are interconnected with low bandwidth links. Some workloads might introduce imbalance and contention on interconnects inside the HMC. It will be interesting to see how works done in NUMA

machines apply inside a single HMC memory chip.

1.7.3 Possible evolutions of multicore processors

Since 2007, manycore processors have been presented to the research community. In this section, we focus on 3 processors that, we believe, are representative of possible evolutions of multicore processors: the Teraflops Research Chip and the Single-chip Cloud Computer (SCC) presented by Intel in 2007 and 2009 and the TILE-Gx8072 processor released in 2011 by Tiler.

The Teraflops Research Chip is an 80-core processor. Cores are connected via a 2D-torus (each core has 4 connections, 1 connection per neighbor). Memory is directly integrated in the chip in order to reduce memory access latencies. Each core is connected to one memory tile in the chip's integrated memory. So, in a way, the Teraflops Research Chip can be viewed as an embedded NUMA system: since each core has a privileged access to a memory tile of the integrated RAM, memory access latencies are non-uniform. The main difference lies in the memory access latencies: because RAM is integrated in the chip, local accesses are much cheaper than that of current NUMA machines and the difference between local and remote memory accesses may be more important than in current NUMA machines.

The Single-chip Cloud Computer (SCC) and the Tiler TILE-Gx8072 processors are very similar. The SCC is a 48-core processor and the TILE-Gx8072 is a 72-core processor. Cores in the SCC are interconnected using a 2D-torus and cores in the TILE-Gx8072 are connected using 5 independent mesh networks. In both processors, cores are grouped into 4 nodes. Each node has its own memory controller. Both processors can be seen as a 4 node embedded NUMA multicore machine.

All these processors raise problems than are already encountered in NUMA machines: the interconnect links between cores may be subject to contention and memory accesses are non-uniform. However, optimizations in these processors are likely to be more complex to implement, due to the complexity of the interconnect topology. Indeed, a single interconnect link can be shared by a large number of nodes, even if they are accessing different memory nodes. Solving contention problems with complex interconnects is still an open issue.

1.7.4 GPGPU and accelerators

In addition to general-purpose multicore processors, machines also have co-processors capable of doing general-purpose calculation. For example, since 2001, graphic processing units (GPU) are able to perform general-purpose calculations using shaders. Intel recently released the Intel MIC accelerator card, designed to speed up calculations done in parallel algorithms. These accelerators communicate with general-purpose multicore processors using the memory subsystem.

Memory management in accelerators introduces two main challenges: prefetching memory on the accelerators before the accelerator actually needs it to minimize latency (as it is the case with processor caches - except that on accelerators prefetching is done manually and on larger scales) and avoiding to slow down memory accesses of general purpose processors by limiting the traffic on the memory subsystem. Currently few applications use these accelerators. These applications are generally manually tuned

for a specific architecture and run in controlled environments. It is currently difficult to assess the impact that accelerators will have on performance of future NUMA systems. Yet, we believe that some techniques used to detect and avoid contention and remote memory accesses could still make sense on NUMA machines equipped with accelerators. For example, a parallel can be drawn between remote memory accesses and expensive communications between accelerators and main memory. Accelerators also open new opportunities for optimizations that do not make sense in classical NUMA machines. For example, it might be a good idea to put threads that communicate with accelerators on the NUMA node that controls the accelerator to minimize communications latencies. It will be interesting to see how these optimizations integrate with existing NUMA optimizations.

1.8 Conclusion

In this chapter we have explained how memory is handled by current hardware. We explained that machines went from UMA to NUMA to meet the increased memory bandwidth needs of applications. We presented the challenges brought by NUMA and classical optimizations used to overcome these challenges. We concluded with a brief overview of possible evolutions of multicore machines and showed problems observed in classical NUMA machines will likely be still present on these architectures.



Contributions

In the previous chapter we have seen that NUMA machines are now mainstream and are likely to continue being mainstream in the years to come. In this context, it is increasingly important to understand and to improve the performance of applications running on NUMA machines. We found out that developers were missing appropriate tools to perform these tasks. The first contribution of this thesis addresses this issue: we present MemProf, the first NUMA profiler allowing the capture of interactions between threads and objects. Then we found out that no existing dynamic memory management algorithm was able to address contentions issues detected using MemProf. The second contribution of this thesis addresses this second issue: we present Carrefour, the first dynamic memory management algorithm that aims at reducing contention on NUMA machines. In this chapter, we briefly introduce these two contributions.

2.1 MemProf

Application-level optimization techniques suffer from a significant shortcoming: it is generally difficult for a programmer to determine which technique(s) can be applied to a given application/workload. Indeed, as we show in Chapter 4, diagnosing the issues that call for a specific application-level technique requires a detailed view of the interactions between threads and memory objects, i.e., the ability to determine which threads access which objects at any point in time during the run of an application, and additional information such as the source and target nodes of each memory access. However, existing profilers like OProfile [40], Linux Perf [41], VTune [42] and Memphis [43] do not provide this required information. Some of them are able to provide this information in the specific case of global static memory objects but these objects often account for a negligible ratio of all remote memory accesses. As an example, for the four applications that we study in Chapter 5, global static memory objects are involved in less than 4% of all remote memory accesses. For other kinds of objects, the only data provided by existing profilers are the target memory address and the corresponding program instruction that triggered the access.

In Chapter 4, we present MemProf, the first profiler able to determine the thread and object involved in a given remote memory access performed by an application. MemProf builds temporal flows of the memory accesses that occur during the run of an application. MemProf achieves this result by (i) instrumenting thread and memory management operations with a user library and a kernel module, and (ii) leveraging hardware support from the processors (Instruction-Based Sampling) to monitor the memory accesses. MemProf allows precisely identifying the objects that are involved in remote memory accesses and the corresponding causes (e.g., inefficient object allocation strategies, saturation of a memory node, etc.). Besides, MemProf also provides additional information such as the source code lines corresponding to thread and object creations and destructions. MemProf can thus help a programmer quickly introduce simple and efficient optimizations within a complex, and unfamiliar code base. We illustrate the benefits of MemProf on four case studies with real applications (FaceRec [44], Streamcluster [45], Psearchy [46], and Apache [47]). In each case, MemProf allowed us to detect the causes of the remote memory accesses and to introduce simple optimizations (involving less than 10 lines of code), and thus to achieve a significant performance increase (the gains range from 6.5% to 161%). We also show that these application-specific optimizations can outperform generic heuristics.

2.2 Carrefour

Some of the memory optimizations found using MemProf could be done automatically by a NUMA-aware kernel. Previous works on NUMA-aware memory placement focused on maximizing locality of accesses and ignored contention issues. However, as we found out in Chapter 1, current NUMA machines suffer more from contention than from remote memory access latencies. This motivates the need for a new NUMA-aware memory placement algorithm, that we call Carrefour. We looked at the problem from a new perspective: Carrefour first tries to decrease contention on memory buses and interconnect links and then tries to improve the locality of memory accesses.

Carrefour relies on multiple classic optimizations presented in Chapter 1 to limit contention. In order to choose between these optimizations, Carrefour relies on observations made using hardware support from the processors (Hardware Counters and Instruction Based Sampling). Implementing these observations efficiently on current hardware presents several challenges because current hardware facilities cannot provide accurate observations with a low overhead.

We implemented Carrefour as an addition to Linux and evaluated it with multiple applications taken from the Parsec Benchmark suite [29], from the NAS Benchmark suite [30], and from the Metis Benchmark suite [31]. Carrefour improves performance of these applications by up to $3.6\times$ and never hurts performance by more than 4%. Moreover, Carrefour constantly outperforms other existing NUMA-aware memory placement algorithms.

Part I

MemProf - Profiling memory accesses on NUMA multicore machines



Existing profiling techniques

Contents

3.1	Hardware profiling facilities	28
3.1.1	Hardware counters	28
3.1.1.1	Description	28
3.1.1.2	Format of Hardware Counters on AMD processors	29
3.1.1.3	Undocumented bugs on AMD processors	30
3.1.2	Instruction Based Sampling (IBS)	31
3.1.2.1	Description	31
3.1.2.2	Overhead of IBS	31
3.1.2.3	Difference between HWC and IBS	32
3.1.3	Precise Event Based Sampling (PEBS)	32
3.1.4	Lightweight profiling (LWP)	33
3.1.5	Hardware breakpoints	33
3.2	Software profiling facilities	34
3.2.1	Tracing	34
3.2.2	System Monitors	35
3.2.3	Cycle accurate simulators	36
3.2.4	Accessed bit	36
3.3	Determining the impact of memory on an application	36
3.3.1	Impact of the speed of memory accesses	37
3.3.2	Is an application accessing memory locally?	38
3.3.3	Is an application creating contention?	38
3.4	Existing profilers	40
3.5	Limitations of existing profilers	42
3.6	Conclusion	43

In this chapter, we describe existing profiling techniques used in NUMA multicore machines. We first describe hardware and software techniques used to collect raw data about the execution of applications (e.g., the number of cache misses). Then we explain how existing profilers use these raw data and we explain how a developer might use existing profilers' outputs to analyze the behavior of their applications. We then present a generic workflow that allows detecting that an application suffers from NUMA effects. We then try to analyze an application that suffers from NUMA effects using existing profilers and show that they do not provide sufficient information to choose and implement an optimization.

3.1 Hardware profiling facilities

Modern processors embed multiple profiling facilities. In this section, we focus on 5 main available hardware-profiling facilities: hardware counters, hardware breakpoints, Instruction Based Sampling, Precise Event Base Sampling, and Lightweight Profiling. These facilities can be used to report information about the execution of instructions or about embedded hardware features (e.g., the prefetcher).

3.1.1 Hardware counters

3.1.1.1 Description

Modern processors have a set of specialized registers dedicated to counting hardware-related events. Hardware Counters registers are incremented every time the event they monitor occurs.

Modern processors support hundreds of different hardware events [48]. These events can be used to count basic hardware events (e.g., the number CPU clocks, the number of cache misses, or the number of prefetch attempts done during a lapse of time) or to dig up very precise information (e.g., the MOESI state of accessed cache lines).

On Opteron and Bulldozer processors, there are two main types of hardware events: “oncore” events and “offcore” events. Oncore events correspond to events that happen inside a core, e.g., operations in the ALU or FPU, L1 or L2 accesses. Offcore events correspond to events that happen outside a core: operations on the L3 and main memory, operations done by the node prefetcher, etc. On Opteron processors, each core contains 4 hardware counter registers. These registers can be used to monitor all oncore and offcore events. When an oncore event occurs, only hardware counter registers of the core on which the event occurred are incremented. When an offcore event occurs, one or multiple hardware counters of the node on which the event occurred are incremented. Because the number of hardware counters that are incremented is not defined by the specification (and actually varies from run to run), it is recommended that only one core per node monitor a specific offcore event. The number of hardware counter registers varies depending on the processor family. For example, Bulldozer processors have 6

counters per core that can only count oncore events and 4 counters per node dedicated to offcore events.

These registers can be configured to generate an interrupt every time their value exceeds a configurable threshold. Using this feature, it is for example possible to generate an interrupt every 100K cache misses. When the interrupt is generated, values in registers are saved and can be accessed by the interrupt handler. Special care must be taken when analyzing the content of registers. Indeed, when the interrupt handler is executed, registers may contain values of instructions that were executed before or after the instruction that triggered the interrupt (this phenomenon is known as *skid*). The skid is due to the fact that modern processors execute multiple instructions out of order and in parallel. In practice, the skid is limited to +/- 2 instructions in AMD Opteron and Bulldozer processors. The skid is not a problem when a developer wants to find out which functions are generating a certain type of events because all the instructions included in the skid are likely to belong to the same function. However, the skid prevents developers from doing detailed analysis of instructions behavior because values in register may correspond to values written by instructions that are different from those which triggered the interrupt.

Per node Hardware Performance Events are even more limited than per core events and can only be used to provide a general overview of the system performance. Even though they might be configured to trigger interrupts, they cannot be used to provide detailed analysis of thread or function behaviors. It is for example impossible to know which functions do remote memory accesses using hardware counters. The reason is that these events are monitored at the node level and interrupts are generated on a random core of the node. The consequence is that the interrupt handler may be executed on a core that is not responsible for the interrupt (e.g., not the core that did a memory access). Thus the register values saved by the interrupt handler may not correspond to the instruction that is responsible for the interrupt.

Most profilers use Hardware Performance Counters in sampling mode, e.g., Perf, Oprofile, VTune and AMD CodeAnalyst. These profilers report the applications, the functions or the instructions that triggered the most interrupts during the profiling session (for the instructions, the analysis might be difficult to do, due to the skid, as seen before). Some profilers use performance counters in counting mode [49] to provide overviews of the system performance and detect anomalies with a low overhead. These profilers watch “vital signs” of the system (e.g., the IPC) and only try to perform detailed analysis when unexpected evolutions of these “vital signs” occur (e.g., a sudden increase in the IPC might indicate a locking issue).

3.1.1.2 Format of Hardware Counters on AMD processors

Hardware counters are configured by writing into special registers called MSRs. In this subsection we briefly describe the binary format of these MSRs. Understanding the binary format of MSRs used by Hardware Counters is important because MSR values often have to be passed as arguments to profilers. For example, Perf allows a developer to monitor any hardware event using the `-e rXXXX` switch, where XXXX is the value that Perf will write in the MSR.

On AMD processor, events are encoded with 3 hexadecimal digits $E_1E_2E_3$. Some events can be refined to count a subset of what they are normally counting using a unit

mask encoded with 2 hexadecimal digits U_1U_2 . For example, table 3.1 presents the impact of the unit masks on what event 1E0 is counting.

Unitmask	Description
0x80	From Local node to Node 7
0x40	From Local node to Node 6
0x20	From Local node to Node 5
0x10	From Local node to Node 4
0x08	From Local node to Node 3
0x04	From Local node to Node 2
0x02	From Local node to Node 1
0x01	From Local node to Node 0

Table 3.1 – Event 1E0 counts memory accesses done from the monitoring node to others nodes. The destination nodes are controlled using the unit mask. When set to 00, the event counts nothing. When set to 01, the event only counts memory accesses from the monitoring node to node 0. When set to FF, the event counts memory accesses from the monitoring node to all other nodes.

The binary format of MSR on AMD processors is the following: the first hex digit of the event has to be written to bits 36-39 of the MSR and the second and third digits have to be written to bits 0-7. The unit mask has to be written to bits 8-15. So, for example, the event 1E0 with a unit mask of FC is encoded as follows: 100000FCE0.

3.1.1.3 Undocumented bugs on AMD processors

Some events on AMD Opteron and Bulldozer processors are not properly counting what is described in the documentation. In this subsection, we describe two of the main undocumented bugs of HWC on AMD machines. We document these bugs because a developer might want to use these events to understand NUMA issues.

Latency of memory accesses. On some machines, the latency of *local* memory accesses is not properly counted. Instead of counting the number of cycles spent waiting for memory, the hardware counter counts the number of unhalted cycles. No fix exists. The latency of remote memory accesses is correct on all AMD processors that we have tested, so it is still possible to get an idea of memory latencies by only monitoring the latency of remote memory accesses (this can be achieved using proper unit masks for the latency events).

Counting the number of memory accesses. AMD machines offer multiples events to count the number of memory accesses: L3 cache misses (event 4E1), CPU to DRAM requests (event 1E0), DRAM accesses (event E0) and CPU requests to Memory (event E9, unit masks A8 and 98). Event 1E0 is the most precise event because it allows precisely understanding the traffic between any pair of two nodes (see Table 3.1). Unfortunately, event 1E0 is “over counting” memory accesses: on most applications, the number of “memory accesses” seen using event 1E0 is roughly 3 times greater than what it should be (e.g., on a memory benchmark, calculating the memory bandwidth using this event gives 3 times the bandwidth that the benchmark is actually achieving).

We found that this “over counting” effect is due to two main hardware features: the prefetcher and HT Assist. When disabling the prefetcher and HT Assist, event 1E0 is not over estimating the number of memory accesses anymore. The “over counting” effect is not due to actual memory traffic. Rather, it seems that event 1E0 is counting cache probes due to the prefetchers and HT Assist even though these probes are not transmitted to the DRAM. Note that, even though event 1E0 is overestimating the number of memory accesses, it is overestimating them in the same way on all nodes of the system; it is thus still possible to use event 1E0 to compute the local access ratio of applications or to compute the imbalance of memory accesses between nodes.

3.1.2 Instruction Based Sampling (IBS)

3.1.2.1 Description

Instruction Based Sampling is a hardware feature introduced by AMD Opteron processors. When IBS is active, the processor randomly tags instructions that it executes. When a tagged instruction retires, the processor generates an interrupt and provides detailed information about the execution of the instruction. Table 3.2 presents a summary of the main information that IBS provides on tagged instructions. IBS mainly provides information on the data that are accessed by tagged instructions, e.g., linear and physical addresses and the level of cache in which the data was found (if it was found in cache).

Name	Description
IbsDcL1TlbMiss	True if the memory access induced a L1 TLB miss
IbsDcLinAd	The virtual address of the data
IbsDcPhysAd	The physical address of the data
NbIbsReqSrc	The level of cache in which the data was found
IbsDcMissLat	If the data was not found in cache, the latency of the memory access

Table 3.2 – Information provided by IBS on a tagged instruction.

IBS was first designed to help AMD improve the performance of their processors, but is currently used by many profiling tools. Perf uses IBS as a replacement for Hardware Performance Counters for some events when it is configured in “precise mode”. For example, in “precise mode” Perf [41] uses IBS to report instructions that miss in L2 cache. The mode is called “precise” because IBS has no skid. Perf and Memphis also use IBS to find which global static objects miss in cache or are accessed remotely. DProf uses IBS to find kernel objects that miss in cache.

IBS has two main limitations: (i) a high overhead and (ii) it only tags instructions and ignores work done in background by hardware components (e.g., prefetchers). We describe these two limitations in the next subsections.

3.1.2.2 Overhead of IBS

Current implementations of IBS do not include any hardware filtering facility (e.g., it is not possible to generate an interrupt only for instructions that miss in cache) so, when a developer is interested in rare events (e.g., instructions that found their data

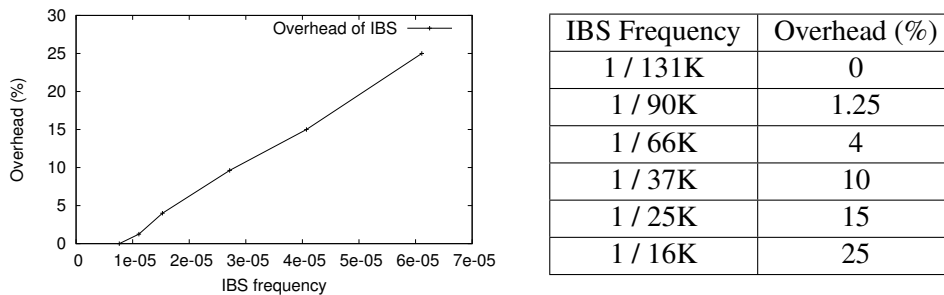

Figure 3.1 – Overhead of IBS, depending on IBS sampling frequency, with the simplest IBS interrupt handler possible.

in a remote L1 cache), he may have to configure IBS to tag instructions with a high frequency in order to have enough sample to do a meaningful analysis.

The overhead of IBS comes from (i) the cost of the interrupts and (ii) reading MSRs to get information on the tagged instructions. Interrupts have direct and indirect costs. Direct costs come from setting the processor in the “right condition” to handle the interrupt: saving registers and fetching the interrupt handler code from caches or from memory. The direct cost of an interrupt varies between 200 and 2000 cycles. Indirect costs come from processor caches and pipelines pollution. Indirect costs are difficult to estimate and depend on the application. Soares et al. [50] have shown that indirect costs can have up to 3 times more impact on performance than direct costs of interrupts. Reading MSRs has a cost of 350 cycles. IBS sets 7 registers per tagged instruction, so the maximum overhead due to reading MSRs is 2450 cycles. Figure 3.1 presents the overhead of IBS with an interrupt handler that reads the 7 IBS registers and exits. The overhead is calculated with an application that increments a counter. We count the time required by the application to perform 1 billion increments. We vary the period of sampling (i.e., the number of instructions executed between every 2 interrupts). As we can see, the overhead grows linearly with the sampling frequency.

3.1.2.3 Difference between HWC and IBS

The second and perhaps most important limitation is that IBS only works on retired instructions and completely ignores work done in background by the processor. For example, it is impossible to monitor memory accesses done by the prefetcher, cache coherency messages, or even work done by instructions that do not retire (i.e., instructions that were executed speculatively in mis-predicted branches). HWC monitors work done in background by the processor, thus observations made using IBS are sometimes different from that made using HWC.

3.1.3 Precise Event Based Sampling (PEBS)

Precise Event Based Sampling (PEBS) is an extension of Hardware Performance Counters that is only available on Intel processors [51]. HWC and PEBS are configured and work in the same way. The main difference between HWC and PEBS is that PEBS

has no skid; a PEBS counter can thus be considered as a precise Hardware Performance Counter. PEBS is currently only available on a subset of HWC events.

Because PEBS has no skid, the information present in registers when the interrupt handler is triggered can be used to find important information about the execution of an application. For example, by combining the content of registers with a binary disassembly of the application, it is possible to know which virtual addresses are accessed by the application¹. If the PEBS register is configured to monitor cache misses, it is thus possible to know which virtual addresses miss in cache. PEBS has some limitations. In particular, as IBS, PEBS can only track events that are directly induced by an instruction; if a memory access is due to the prefetcher, it cannot be accounted for by PEBS.

PEBS is used by many profilers in place of HWC to provide more accurate profiling results. For instance, Perf uses PEBS when the “precise” switch is active. VTune also uses PEBS when the processor supports it.

3.1.4 Lightweight profiling (LWP)

Lightweight Profiling (LWP) is an extension of AMD processors that aims at providing the same level of details as IBS with less overhead. To reduce overhead, LWP relies on two main techniques: (i) a ring buffer, managed by the hardware, that is used to store information about tagged instructions; interrupts are only sent when the buffer is full, and (ii) filters; LWP allows developer to specify filters (e.g., a filter that allows only monitoring instructions that miss in cache).

The LWP ring and LWP operations are manipulated using special instructions. These instructions can be used in user mode, so LWP can be entirely controlled by an application without any kernel support².

Currently, LWP is not fully implemented in Hardware. It only stores basic information about instructions being executed (the instruction pointer and a timestamp) and filters are not implemented. In theory, LWP could be used in all profilers that use IBS to provide the same information with less overhead.

3.1.5 Hardware breakpoints

Processors can be configured to generate an interrupt every time a load or a store is performed on a range of virtual memory addresses. These interrupts are configured using Hardware Breakpoint Registers. Modern processors usually have 4 Hardware Breakpoint Registers. These registers are configured to monitor read or writes but not both at the same time. Consequently, 2 registers are required to monitor all memory accesses done on a virtual memory range.

The maximum size of the range of virtual addresses that a processor can monitor depends on its family. Itanium processors let the system configure the beginning and the end of the virtual address range. It is thus possible to generate an interrupt for

¹A binary disassembly is required because virtual addresses accessed by instruction can be stored in any general purpose register; only a disassembly of the binary indicates which registers are used by an instruction to perform a load or a store

²The kernel only needs to set a bit in a MSR register to allow LWP profiling. This can be done during the kernel initialization.

any range of virtual memory. Intel and AMD i386 and x86_64 processors are less flexible and enforce a fixed range size equal to the size of a line of cache (64B). Because of the limited number of register and because of the small range size, on i386 and x86_64 machines, few profilers use Hardware Breakpoint Registers. These registers are used in debuggers. Typical use of these registers include generating an interrupt every time a variable is accessed (to track dependencies or to help understand complex parallel access patterns), or checking accesses on some arrays' boundaries (an interrupt is generated when the application does a memory access on the cache lines located before or after the array boundaries). Hardware Breakpoints usually induce a high overhead when they are used on memory regions that are frequently accessed. Indeed, an interrupt is generated on every access (even if the data is in cache).

Currently, the only profiler that uses Hardware Breakpoint Registers is DProf [12]. DProf uses Hardware Breakpoint Registers to monitor accesses done on specific kernel structures. DProf only considers accesses done to one field of the monitored structure at a time, so an application has to be launched multiple times to track accesses done to different fields of a structure.

3.2 Software profiling facilities

In the previous section, we have presented hardware facilities that are used to help understand applications' performance. In this section, we present software techniques that can be used to achieve the same goal. First, we present tracing tools that allow developers to add code in existing binaries. Then, we present system monitors that output statistics maintained by the kernel. Then, we present cycle accurate simulators that can be used to simulate and understand hardware issues. We finally present the "accessed bit" method that allows developers to find out which memory pages are accessed by applications.

3.2.1 Tracing

The simplest software-based way to profile an application in software is to add trace points (*probes*) in key functions of the application and of the kernel. A trace point adds some monitoring logic to a function, e.g., it can record the number of times the function is called, the total time spent in the function or code paths that lead to the function. Trace points can be statically compiled in an application or dynamically added during the execution of the application. Typical usages of trace points are monitoring time spent in locks or finding code paths that lead to deadlocks or abnormally long critical sections.

Trace points have many advantages: they often have little overhead and only impact functions that the developer wants to trace. However, tracing is only relevant to analyze precise portion of an application (e.g., a function or a lock): tracing all function calls adds overhead and trace outputs are likely to be difficult to analyze.

Tracing can be done at the application level or at the kernel level. Current Linux kernels are shipped with many tracing facilities. The easiest tracing tool to use is the Perf Software Event subsystem. The Software Event subsystem counts functions calls in the important parts of the kernel (e.g., it counts the number of page faults or the

number of context switches). Software Events are implemented to mimic the behavior of Hardware Performance counters, and are used in Perf exactly as Hardware Counters: an interrupt can be generated when the Software Event counter reaches a threshold (“sampling mode”) and counters can be read using Perf syscalls as usual Hardware Counters (“counting mode”). Beside Software Events, the kernel offers a wide range of powerful tracing utilities. SystemTap [52], for example, allows a developer to insert code at any location in the kernel. SystemTap inserts trace points dynamically in the kernel by replacing the code that the kernel is executing (hot code swapping). Other tracing tools like `ptrace` can also be used to track system calls and to gather system calls arguments.

Pin [53] is a dynamic binary instrumentation tool: Pin adds functions (*hooks*) inside any compiled binary according to rules defined by the developer. Pin dynamically adds the *hooks* when the binary is loaded in memory, so no recompilation of the program is required. Pin can be used as a classical tracing tool, but Pin also works at the instruction level: rules can be defined on the instruction level (assembly code) or at the function level. Using Pin, it is for example possible to count the number of load vs. the number of stores executed by an application to compute the read/write ratio of the application. In order to do that, a developer creates a rule that states that a “counting function” should be called before each load and that another “counting function” should be called before each store. At the end of the execution, the developer can compare the number of times the “load counting function” has been called to the number of times the “store counting function” has been called to compute read/write ratio of the application.

Pin is a powerful tool, but has some limitations. The first limitation is its overhead. Pin adds approximately 30% overhead when it runs with an empty *hook* [54]. The overhead grows with the number of *hooks* and the complexity of these *hooks*. Complex *hooks* located in code path that are frequently used can easily add a 100x overhead to the profiled application. The second limitation is that Pin does not take into account the hardware. It is for example impossible, using Pin rules, to consider only instructions that create cache misses.

3.2.2 System Monitors

System monitors are tools that are used to report the load of various components of the machine, like the CPU load, the disks load or the network load. These tools usually use statistics collected by the kernel (for example, the CPU load can be calculated by computing the ratio of time occupied by the *idle process*).

The most used system monitor is the `sar` (System Activity Report) tool available in most Linux and Solaris distributions. `Sar` reports global statistics on the system usage. It can be used to monitor most important parts of the kernel or to get precise statistics about I/Os (e.g., number of packets sent per second, type of the packets, average size of the packets). `Sar` only reports statistics at the machine or CPU level. To get usage statistics at the process level, a developer can use more specific tools like `iostat` or `disktop` to visualize I/Os done by processes and to correct abnormal processes behaviors. Some tools like `latencytop` can also be used to visualize abnormal latencies in I/Os or locks per process.

3.2.3 Cycle accurate simulators

A cycle accurate simulator is an application that simulates a complete machine accurately. A cycle accurate simulator can be used to predict and to understand the performance that an application would get on the simulated machine. The main advantage of running an application on a cycle accurate simulator is that every single performance issue can be tracked down to its root cause. Indeed, contrarily to a real machine that only offers a handful of hardware counters to monitor its state, in a simulator it is possible to monitor every single component of the simulated machine.

Cycle accurate simulators are thus powerful tools to understand the behavior of an application. They are however rarely used. The main reason is that cycle accurate simulators are notoriously hard to configure: every single aspect of the simulated machine has to be taken into account to provide accurate results (e.g., the algorithms used by the prefetcher or the algorithms used by the branch predictors which, most of the time, are not publicly available). Most of the time it is not possible to configure the simulator accurately using only documentation provided publicly by hardware vendors. The second limitation of cycle accurate simulators is their overhead. Applications running in a simulator usually run hundreds of times more slowly than application running on bare metal.

3.2.4 Accessed bit

The accessed bit method is a hybrid approach that relies on the software and the hardware to monitor accessed pages. The name “accessed bit” comes from the “accessed bit” present in the page table: when the hardware accesses a memory page, it sets the “accessed bit” of the page’s TLB entry to 1. The accessed bit is normally used in LRU algorithms to swap pages that were not accessed recently, but can also be used to track - in a coarse grain manner - accesses to pages.

The “accessed bit” method works as follows: (i) a daemon periodically resets the accessed bit of all pages to 0 and after a short period of time (ii) the daemon scans all pages and maintains statistics on all pages that were accessed since step (i). If the daemon runs frequently enough, it is possible to compute statistics on page accesses.

This method has some limitations. First, the precision of the method depends on the frequency of the scans. Since the scanning requires parsing all entries of all page tables, it has a huge overhead when run too frequently [55]. Second, this method is very coarse grain, because it only identifies accesses at the page level. Third, it is not possible to know which thread or which cores accessed the page during the time period, and if the accesses to the page were resolved in cache or in memory. Thus, the “accessed bit” method can only be used to compute coarse grain statistics about the “hotness” of pages.

3.3 Determining the impact of memory on an application

As we have seen in the previous section, a developer can use many software and hardware profiling facilities to analyze applications. In this section, we first present coarse grain techniques to see if an application is impacted by the speed of its memory accesses (i.e., to understand if an application is impacted by contention or by the locality of its memory accesses). Indeed, some applications do very few memory accesses and

are not impacted by NUMA effects; it is best for a developer to check that an application might be limited by its memory accesses before trying to perform any complex profiling. Then we show how to profile DRAM accesses. We first show how to measure the local access ratio of an application and then how to check if an application is creating contention. Out of the 12 studied profiling facilities, only 4 can be used to try to understand the impact of DRAM accesses on application: hardware counters, IBS, LWP, PEBS and cycle accurate profilers. Indeed, hardware breakpoints and most software approaches are not able to report any information about the type of memory accesses an application is doing (i.e., they cannot distinguish an access done in cache and an access done in DRAM).

3.3.1 Impact of the speed of memory accesses

Before starting to profile an application, a developer often wants to be sure that the application is impacted by the speed of its memory access. The easiest way to know if an application is impacted by the speed of its memory accesses is to compare the performance of the two following setups:

- In the first setup, all threads of the application are located on one node and the application allocates its memory locally. This can, for example, be achieved using the following command line:

```
numactl --cpunodebind=0 --membind=0 <application>
```

- In the second setup, all threads of the application are located on one node and the application allocates its memory remotely. This can, for example, be achieved using the following command line:

```
numactl --cpunodebind=0 --membind=1 <application>
```

If the application performs better in the first setup than in the second setup, then the application is impacted by the speed of its memory accesses. Indeed, in the second setup, all memory accesses done by the application are done remotely so, on average, all memory accesses of the second setup are 20% slower than that of the first setup.

If it is not possible to run the application using the previously described setups, a developer can also measure the number of “Memory Accesses done Per Instruction” (MAPI) of the application. If the MAPI is “high”, then the application is likely to be impacted by the speed of its memory accesses; usually a MAPI over 0.005 is considered “high” [56]. In order to compute the MAPI of an application, a developer can use the Perf profiler as follows:

```
perf stat
-e r100000FFFE0,rC0
<application>
```

Perf will report the number of memory accesses (event 100000FFFE0) and the number of instructions (event C0) done by the application. The MAPI is calculated by dividing the number of memory accesses by the number of instructions.

3.3.2 Is an application accessing memory locally?

If an application is impacted by the speed of its memory accesses, then a developer might want to compute the local access ratio (LAR) of the application. If the LAR is not 100%, then the application might be limited by the extra latency added by remote memory accesses.

The local access ratio of an application can be calculated using the Perf profiler as follows:

```
perf stat -e rA8E9,r98E9 <application>
```

Perf will report the number of local memory accesses (event A8E9) and the number of remote memory accesses (event 98E9) done by the application. The LAR is calculated by dividing the number of local memory accesses by the total number of memory accesses:

$$\frac{\#A8E9}{(\#A8E9 + \#98E9)}$$

with #XXXX representing the number of samples of event XXXX reported by Perf.

3.3.3 Is an application creating contention?

As we have seen in Section 1.5.3, contention is the main memory effect that can degrade performance. Contention occurs when a memory bus or an interconnect link operates at its maximum capacity.

AMD processors are interconnected using Hypertransport links. Each processor has up to 6 Hypertransport links and each Hypertransport link can be subdivided into 2 sublinks. So, contention can appear on 1 of the 12 Hypertransport links of all processors. The following command can be used to measure the load of the two sublinks of the first Hypertransport links of all processors:

```
perf stat -A
-C `numactl --hardware | grep cpus | awk '{print \$4}' |
paste -s -d, `
-e r1ff6,r17f6,r9ff6,r0x97f6
<application>
```

The load of the sublink 0, for all nodes, is computed as follows:

$$1 - \frac{\#17f6}{(\#17f6 + \#1ff6)}$$

The event 17F6 counts the number of NOP packets transmitted on the sublink 0 of link 0 and the event 1FF6 counts the total number of packets transmitted on the sublink 1 of link 0. NOP packets are transmitted when the sublink is idle. Because all packets have the same size, it is possible to compute the load of the sublink by computing the ratio of NOP packets over the total number of packets transmitted on the link. Note that the Perf command is a bit more complex than the command used to compute the LAR. The reason is that we want to have profiling results *per node* and not a global average. The -A switch tells Perf to output the number of samples per CPU. And because Hypertransport links are “per node components”, the command only starts profiling on one CPU per node (-C switch that takes a list of CPUs as argument).

The same computation can be done to measure the load on the sublinks of the Hypertransport links 1, 2, 3, 4 and 5 of all processors. Note that the maximum usage of

a sublink is not always 100%. The maximum usage depends on the processor family and the width of the Hypertransport links. To measure the maximum usage of a link, the easiest solution is to run the above profiling while running a memory benchmark that makes all its memory accesses via the link that needs to be monitored. The link usages observed using this benchmark can be used as the “maximum usage” values of the links.

Measuring the load of a memory bus is trickier. To measure the load of a memory bus, we count the number of 32-byte and 64-byte packets that transit through a memory bus. We then multiply the number of packets by their size and compare the value to the maximum bandwidth achievable by the bus. To get the number of 32- and 64-byte packets that transit through a link, the following Perf command can be used:

```
perf stat -A
-C `numactl --hardware | grep cpus | awk '{print \$4}' |
  paste -s -d, `
-e r100002FF0,r1000057F0
<application>
```

The 100002FF0 event counts the number of 32-bit reads and write performed to the local memory controller of the monitoring CPUs. The 1000057F0 event performs the same operation of 64-bit reads and write. Both events are monitored per CPU (-A switch). The load of a memory controller is computed as follows (the computation has to be performed for each node):

$$\frac{(\#100002FF0 + \#1000057F0)}{(\text{Duration of the benchmark} * \text{Maximum bandwidth of the node})}$$

The maximum bandwidth of a node can be easily calculated using a memory benchmark (e.g., all cores accessing sequentially an array located on the node).

To measure contention, an other solution is to measure the latency of memory accesses. If the average latency of memory accesses done by the application is close to the latency of memory accesses of an idle machine (see Table 1.2), then the application does not create contention. On applications that create contention, we have observed that the average latency may be up to 10 times that of an idle machine. The following command can be used to measure the latency of memory accesses using Perf:

```
perf stat
-e r10000ffe2,r10000ffe3,r10000ffe4,r10000ffe5
<application>
```

The 10000ffe2 and 10000ffe4 events count the total number of cycles spent doing memory accesses and the 10000ffe3 and 10000ffe5 events count the number of memory accesses. The average latency of memory accesses is calculated as follows:

$$\frac{(\#10000ffe2 + \#10000ffe4)}{(\#10000ffe3 + \#10000ffe5)}$$

with #XXXX representing the number of samples of event XXXX reported by Perf. Note that, as seen in Section 3.1.1.3, the latency counter might report wrong values for local memory accesses. If it is the case, Perf can be configured to monitor only remote memory accesses latencies.

3.4 Existing profilers

Profilers can be classified into three main categories: profilers that report global statistics about the execution of an application (global profilers), profilers that analyze work done by instructions (instruction-oriented profilers) and profilers that analyze accessed data (data-oriented profilers). In this section we present these three types of profilers and explain how they can be used to understand the behavior of an application.

Global profilers. Global profilers report general statistics about the execution of an application. Global profilers consider applications as black boxes. They can only be used to understand coarse-grain issues, e.g., the fact that an application is doing remote memory accesses – without knowing what the application is accessing remotely.

The main advantage of global profilers is their lack of overhead. A global profiler is usually scheduled just before and just after the execution of an application and not scheduled in between.

Perf stat [41], used in the previous Section, is a global profiler. It is simple to use, but rather limited: it can only be used to count the number of time monitored events occur. The tool provides no further analysis. For advanced analysis, a developer can use likwid-perfctr [57] that offers a predefined set of rules to compute useful metrics (e.g., the MFlops count of an application). Miniprof [58] is an other global profiler; it can compute most global metrics (e.g., MAPI, LAR) and can plot graphics showing the evolution of these metrics during the execution of the application. Sar (see Section 3.2.2) is also a global profiler; it reports global statistics about I/Os, scheduling and memory usage.

Instruction-oriented profilers. Instruction-oriented profilers report the instructions (or functions) that account for most of the monitored events. For example, if a developer monitors CPU cycles, these profilers will report the instructions (or functions) in which most of the time is spent. Some profilers allow visualizing the evolution of the “top functions” through time. Perf record/report/annotate [41], Oprofile [40], VTune [42], AMD CodeAnalyst [59] are example of instruction profilers. Figure 3.2 (a) presents the output of Perf report on FaceRec. Figure 3.2 (b) presents the output of Perf annotate on FaceRec. Using these two outputs a developer can find functions and instructions that take time to execute.

Data-oriented profilers. Data-oriented profilers report the objects that account for most of the monitored events. For example, if a developer monitors remote memory accesses, these profilers will report objects that are the most accessed remotely.

Currently, few data-oriented profilers exist. Perf data [41], VTune [42], DProf [12] and Memphis [43] are example of data-oriented profilers. DProf reports kernel objects that create caches misses. DProf does not work on objects allocated outside the kernel. Perf, VTune and Memphis only work on static globally allocated objects. Memphis was specifically designed to find objects that are accessed remotely. Perf and VTune can use PEBS events. They report the global static objects that account for most of the monitored PEBS event. Perf also has an experimental support for IBS.

```

Samples: 8M of event 'cycles', Event count (approx.): 4810784460842
- 83.44% face_project face_project      [.] transposeMultiplyMatrixL
+ transposeMultiplyMatrixL
+ 10.63% face_project libc-2.15.so      [.] _IO_fread
+ 0.80%  face_project libc-2.15.so      [.] _IO_file_xsgetn_internal
+ 0.54%  face_project face_project      [.] mean_subtract_images
+ 0.48%  face_project libc-2.15.so      [.] __memcpy_sse2
+ 0.28%  face_project [kernel.kallsyms] [k] copy_user_generic_string
+ 0.22%  face_project [kernel.kallsyms] [k] call_function_interrupt
+ 0.22%  face_project face_project      [.] readFloat

```

(a)

```

                                for (k = 0; k < A->row_dim; k++) {
0.00 170: test    %ecx,%ecx
0.00     ↓ jle    lba
0.00     mov    0x10(%rbx),%rax
0.00     mov    %r8,%rdx
0.00     add    (%rax,%r11,1),%rdx
0.00     mov    0x10(%r12),%rax
0.02     mov    (%rax,%r8,1),%rdi
0.01     mov    0x10(%rbp),%rax
0.00     movsd  (%rdx),%xmm1
0.00     mov    (%rax,%r11,1),%rsi
0.00     xor    %eax,%eax
0.00     nop
                                ME( P, i, j ) += ME(A, k, i) * ME(B, k, j);
19.96 1a0: movsd  (%rdi,%rax,8),%xmm0
29.40     mulsd (%rsi,%rax,8),%xmm0
1.14     add    $0x1,%rax
                                ME( P, i, j ) = 0;
                                }
}

```

(b)

Figure 3.2 – Output of perf report (a) and perf annotate (b) on FaceRec. (a) The transposeMultiplyMatrixL function represents 83% of the cycles and (b) most of the time is spent in a loop that multiplies two matrices.

3.5 Limitations of existing profilers

This section studies whether existing profilers can help detecting inefficient patterns such as the ones described in Section 1.6. We show below that these profilers are actually not able to do so in the general case, because they cannot precisely determine whether two threads access the same object (in main memory) or not³. We use FaceRec, a face recognition application, as an example. FaceRec performs 63% of its memory accesses remotely.

Using existing profilers, a developer can determine, for a given memory access performed by a thread, the involved virtual and physical addresses, as well as the corresponding source code line (e.g., a C/C++ statement) and assembly-level instruction, and the function call chain. In order to extract inefficient thread/memory interaction patterns from such a raw trace, a programmer has to determine if two given individual memory accesses actually target the same object instance or not.

In the case of global statically allocated objects, the answer can be found by analyzing the information embedded in the program binary and the system libraries, from which the size and precise virtual address range of each object can be obtained. This feature is actually implemented by tools like VTune and Memphis. Unfortunately, according to our experience with a number of applications, this kind of objects only account for a very low fraction of the remote memory accesses (e.g., less than 4% in all applications studied in Section 5). In the more general case, i.e., with arbitrary kinds of dynamically allocated objects, the output of existing profilers (addresses and code paths) is not sufficient to reach a conclusion, as explained below.

First, existing profilers do not track and maintain enough information to determine the enclosing object instance corresponding to a given (virtual or physical) memory address. Indeed, as the lifecycle of dynamic objects is not captured (e.g., dynamic creations/destructions of memory mappings or application-level objects), the address ranges of objects are not known. Moreover, a given (virtual or physical) address can be reused for different objects over time. In addition, virtual-to-physical mappings can also evolve over time (due to the swapping activity or to page migrations) and their lifecycle is not tracked either.

Second, the additional knowledge of the code path (function call chain and precise instruction) that causes a remote memory access is also insufficient to allow determining if several threads access the same memory object. Some applications are sufficiently simple to determine the accessed object using only the code path provided by existing profilers. However, in practice, we found that this was not the case on any of the applications that we studied. In general, the code path is often helpful to determine the object *type* related to a given remote memory access, but does not allow pinpointing the precise object *instance* being accessed. Indeed, the internal structure and workloads of many applications are such that the same function is successively called with distinct arguments (i.e., pointers to distinct instances of the same object type), and only a subset of these invocations causes remote memory accesses. For instance, in Section 5.1, we will show the example of an application (FaceRec) that processes nearly 200 matrices, and in which only one of them is involved in a large number of remote memory accesses.

³From the application-level perspective, these *accesses* correspond to object allocations, destructions, as well as read or write operations.

3.6 Conclusion

In this chapter, we have described hardware and software profiling facilities available in NUMA multicore machines. We have explained how to detect that an application is impacted by the speed of its memory accesses. We have presented existing profilers, and we have seen that these profilers do not provide sufficient information to understand NUMA effects in an application.



MemProf: a memory profiler for NUMA multicore machines

Contents

4.1 Overview	45
4.2 Timelines of thread-object access patterns	46
4.3 Implementation	47
4.3.1 Event collection	47
4.3.2 TEF and OEF construction	49
4.4 Example usage	50
4.5 Conclusion	52

In this chapter, we present MemProf, the first NUMA profiler allowing the capture of interactions between threads and objects. More precisely, MemProf is able to associate remote memory accesses with memory-mapped files, binary sections thread stacks, and with arbitrary objects that are statically or dynamically allocated by applications. This chapter is organized as follows: we first give an overview of MemProf. Second, we describe the output provided by MemProf. Finally, we describe how MemProf can be used to detect patterns such as the ones presented in Section 1.6. MemProf code is available for download at the following url: <https://github.com/Memprof>.

4.1 Overview

MemProf aims at providing sufficient information to find and implement appropriate solutions to reduce the number of remote memory accesses. The key idea behind MemProf is to build temporal flows of interactions between threads and in-memory objects. Intuitively, these flows are used to “go back in an object’s history” to find out which and when threads accessed the object remotely. Processing these flows allows

understanding the causes of remote memory accesses and thus designing appropriate optimizations.

MemProf distinguishes five types of objects that we have found important for NUMA performance troubleshooting: global statically allocated objects, dynamically-allocated objects, memory-mapped files, sections of a binary mapped by the operating system (i.e., the main binary of an application or dynamic libraries) and thread stacks. MemProf associates each memory access with an object instance of one of these types.

MemProf records two types of flows. The first type of flow represents, for each profiled thread, the timeline of memory accesses performed by this thread. We call these flows Thread Event Flows (TEFs). The second type of flow represents, for each object accessed in memory, the timeline of accesses performed on the object. We call these flows Object Event Flows (OEFs).

These two types of flows give access to a large number of indicators that are useful to detect patterns such as the ones presented in Section 1.6: the objects (types and instances) that are accessed remotely, the thread that allocates a given object and the threads that access this object, the node(s) where an object is allocated, accessed from and migrated to, the objects that are accessed by multiple threads, the objects that are accessed in a read-only or in a read-mostly fashion, etc. Note that different views can be extracted from MemProf's output, i.e., either focused on a single item (thread/object) or aggregated over multiple items. In addition, the temporal information can be exploited to detect some specific phases in an application run, e.g., read/write phases or time intervals during which a memory object is accessed with a very high latency (e.g., due to the intermittent saturation of a memory controller).

4.2 Timelines of thread-object access patterns

MemProf builds one Thread Event Flow (TEF) per profiled thread T . An example of TEF is given in Figure 4.1 (a). The TEF of a given thread T contains a list of "object accesses"; each "object access" corresponds to a main memory access performed by T . The "object accesses" are organized in chronological order inside the TEF. They contain: (i) the node from which the access is performed, (ii) the memory node that is accessed, (iii) a reference to the Object Event Flow of the accessed object, (iv) the latency of the memory access, (v) a boolean indicating whether the access is a read or a write operation, and (vi) a function callchain. The TEF of a given thread T also contains some additional metadata: the PID of T and the process binary filename. These metadata allow computing statistics about threads of the same process and the threads of a common application.

Object Event Flows (OEFs) provide a dual view of the information contained in the TEFs. MemProf builds one OEF per object O accessed in memory. An example of OEF is given in Figure 4.1 (b). The OEF of an object O is composed of "thread accesses", ordered chronologically. Each "thread access" corresponds to a memory access to O . The "thread accesses" store similar information as the one found in "object accesses". The only difference is that instead of containing a reference to an OEF, an "object access" contains a reference to the TEF of the thread accessing O .

The OEF of a memory object O also contains metadata about O : the type of the object (among the 5 types described in Section 4.1), the size of the object, and the line

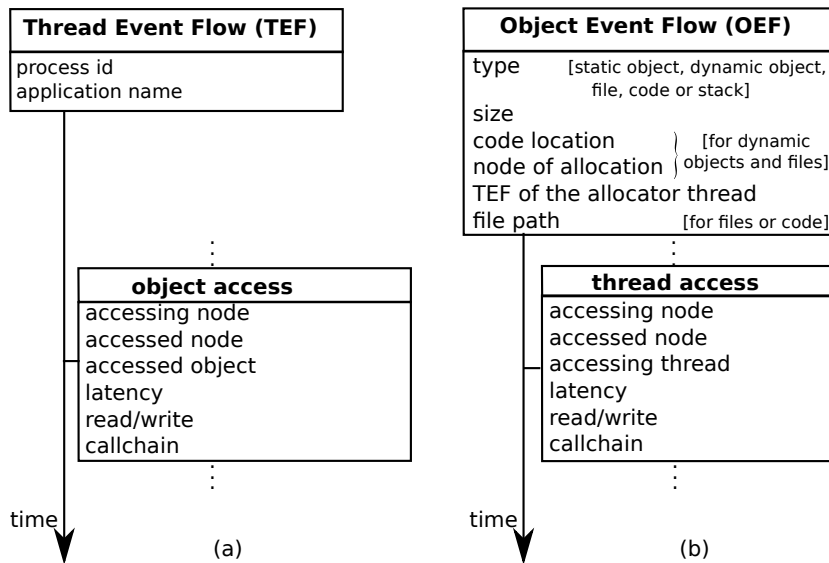

Figure 4.1 – The two types of flows built by MemProf. There is (a) a Thread Event Flow per profiled thread, and (b) an Object Event Flow per object accessed during the profiling session.

of code where the object was allocated or declared. Besides, there are some additional metadata for a dynamically allocated object, as depicted in Figure 4.1.

4.3 Implementation

In this section, we present the implementation of MemProf for Linux. MemProf performs two main tasks, illustrated in Figure 4.2. The first task (online) consists in collecting events (thread creation, object allocation, memory accesses, etc.) that are then processed by the second task (in an offline phase), which is in charge of constructing the flows (TEFs and OEFs). We review each task in turn.

4.3.1 Event collection

The event collection task consists in tracking the life cycle of objects and threads, as well as the memory accesses.

Object lifecycle tracking.

MemProf is able to track the allocation and destruction of different types of memory objects, as described below.

MemProf tracks the lifecycle of dynamically allocated memory objects and memory-mapped files by overloading the memory allocation functions (`malloc`, `calloc`, `realloc`, `free`, `mmap` and `munmap`) called by the threads that it profiles. MemProf can also be adapted to overload more specialized functions when an application does not use the standard allocation interfaces. Function overloading is performed by linking the profiled applications with a shared library provided by MemProf, through the dynamic

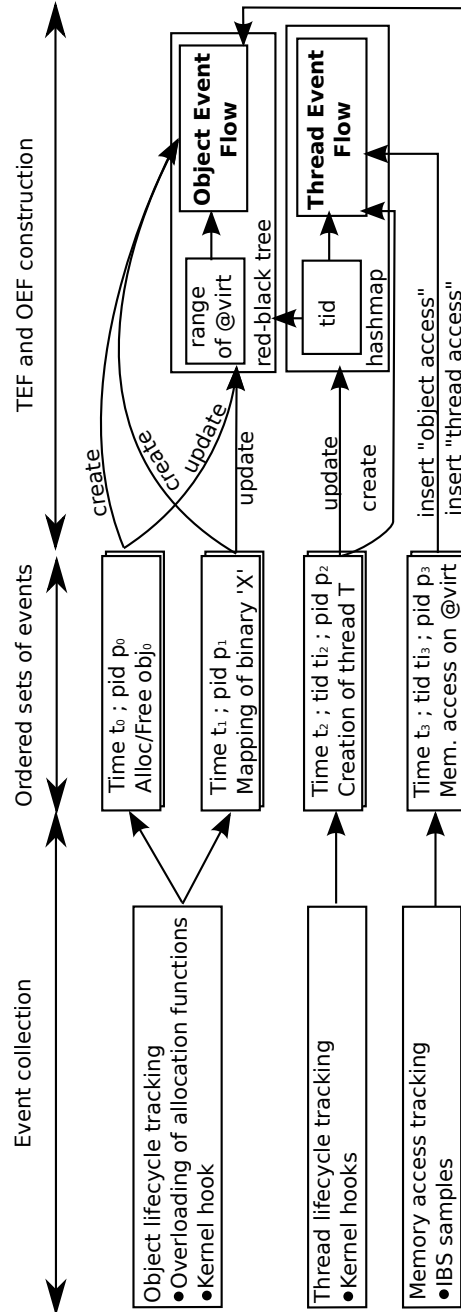

Figure 4.2 – Implementation of MemProf. MemProf performs two tasks: event collection (online) and flow construction (offline). Due to space restrictions, we only present the most important fields of the collected events.

linker's `LD_PRELOAD` and `dlsym` facilities¹.

MemProf tracks the lifecycle of code sections and global static variables with a kernel module that overloads the `perf_event_mmap` function. This function is called on every process creation, when the binary and libraries of the process are mapped in memory. It provides the size, virtual address and “content” (e.g., file name) of newly mapped memory zones.

For each kind of object, MemProf stores the virtual address of the created or destroyed object. It also stores a timestamp, the tid of the calling thread, the CPUID on which the function is called and a callchain. The timestamp is required to determine the lifecycle of memory objects. The tid is necessary to know in which virtual address space the object is allocated. The CPUID is needed for the corresponding OEF metadata. The callchain is required to find the line of code where the object was allocated.

Thread lifecycle tracking. In order to detect thread (and also stack) creations and destructions, MemProf overloads two kernel functions: `perf_event_task` and `perf_event_comm`, which are called upon such events. The `perf_event_task` function provides the thread id of newly created/destroyed threads, and the `perf_event_comm` function provides the name of newly created threads. MemProf records these metadata and associates them with a timestamp and a pid.

Memory access tracking. Memory accesses are tracked using Instruction Based Sampling (see Section 3.1.2). For tagged instructions that reference a memory location, IBS collects the virtual and physical address of the location, the number of clock cycles required to fetch the data, the level where the data was found in the memory hierarchy (in one of the caches, in the local DRAM bank or in a remote DRAM bank), and the access type (read or write). MemProf configures an IBS handler per cores and, when an IBS interrupt occurs, MemProf stores this information in per core buffers. In addition to the information provided by the IBS registers, the MemProf's kernel module also saves a timestamp, the CPUID of the core, as well as the thread id and stack boundaries of the executing thread.

4.3.2 TEF and OEF construction

Once the events have been collected, MemProf builds (offline) the OEF and TEF of the profiled application(s). Since the creation of TEF and OEF are costly, MemProf only builds them for the threads and objects that a developer wants to study.

As illustrated in Figure 4.2, the events are first ordered by timestamp. MemProf then iterates over the ordered list of events and builds the flows as follows. MemProf creates a new TEF each time a new thread is created and an OEF each time a new object is allocated. MemProf stores (i) the TEFs in a hashmap indexed by the tid of their thread and (ii) the OEFs in a per-process red-black tree structure. This red-black tree allows finding if a virtual address corresponds to a previously allocated object (e.g., if an object O is allocated on the virtual address range $[0x5 - 0x10]$, then a request for the address $0x7$ will return the OEF of O).

¹MemProf can thus work on applications whose source code is not available. However, its insight may be somewhat restricted in such a case (e.g., given the lack of visibility over the accessed object types).

For each memory access to a given virtual address, MemProf (i) creates a “thread access” and inserts it in the TEF of the thread that performed the memory access, and (ii) searches in the red-black tree for the OEF that corresponds to the accessed virtual address; if it exists, MemProf creates an “object access” and inserts it in the OEF. Note that in most cases, the OEF exists in the red-black tree; the only exceptions are (i) when a memory access targets the stack of a thread, and (ii) when the physical address is outside the valid range of physical addresses². MemProf assigns all memory accesses performed on stacks to a single (per-process) OEF representing all stacks. Indeed, we observed in practice that stacks represent only a small percentage of remote memory accesses and it is thus sufficient to regroup all memory accesses performed on stacks in a single OEF. Moreover, MemProf ignores physical addresses that are outside the valid range of physical addresses.

4.4 Example usage

In this Section, we show how to use MemProf to profile an application. We use FaceRec as an example. We first show how to collect samples. Then we show how to interpret MemProf’s output and show how it can help choose between the optimizations described in Section 1.6.

Profiling. Profiling an application is done in one line:

```
<memprof_path>/scripts/profile_app.sh <app>
```

The script loads the kernel module, starts IBS sampling and sets up required hooks to monitor objects creations and destructions.

After the profiling session, three files will be created: *ibs.raw*, *perf.raw* and *data.processed.raw*. The *ibs.raw* files contains the IBS samples. The *perf.raw* file contains the process creation and destruction information. The *data.processed.raw* file contains the object creation and destruction information.

Finding accesses that are accessed remotely. To get the objects that account for most remote memory accesses, a developer can use the following command:

```
<memprof_path>/parser/parse
--perf perf.raw --data data.processed.raw ibs.raw
-L -u -a <app_name> --top-obj
```

The `-L` switch filters samples to keep only remote memory accesses. The `-u` switch filters samples to keep only memory accesses done in userland (vs. in kernel). The `-a` filters samples to keep only samples done by the profiled application. Finally the `--top-obj` switch tells MemProf to show a list of the objects, sorted by the number of samples that access the object. The output is a list of lines that look as follows:

```
274 - makeMatrix+0x59
    6479348 [6479348 0% local]
    [89.87% total] [...]
```

²The hardware creates IBS samples with such addresses when it monitors special assembly instructions like `rdtsc11`, which is used to read the timestamp counter.

This line represents the “top object” of FaceRec. The object unique id of the object is 274. This number can be used in other commands of MemProf (see below); it is an internal number used by MemProf and does not mean anything outside MemProf scripts. The object was allocated in the `makeMatrix` function (exactly at the 59th instruction after the beginning of the function). 6479348 remote memory accesses were performed on the object. Note that because the `-L` switch is used (i.e., “consider only remote memory accesses”), the total number of accesses reported by MemProf (first occurrence of 6479348) is equal to the number of remote memory accesses (second occurrence of 6479348). This object represents 89.87% of the remote memory accesses and is thus a good candidate for optimization.

Outputting the OEF of an object. The `--obj <uid>` switch of MemProf is used to output the OEF of the object `<uid>`. The uid corresponds to the unique identifier outputted by the `-top-obj` switch (see previous paragraph). With our example, the command line to plot the OEF of object #274 is:

```
<memprof_path>/parser/parse
--perf perf.raw --data data.processed.raw ibs.raw
-L -u -a <app_name> --obj 274
```

MemProf outputs the metadata associated with the object and the list of memory accesses done to the object.

```
Object was allocated from the following path:
    makeMatrix+0x59 [0x404220]
        readSubspace [0x408eb4]
            main [0x40194d]
Object is here: 7fe12a7ec010-7fe12b73edb0
OEF:
x          readDouble
x          readDouble
*          readDouble
*          readDouble
x          readDouble
*          readDouble
*          readDouble
[...]
  x          transposeMultiplyMatrixL
x          transposeMultiplyMatrixL
  x          transposeMultiplyMatrixL
    x          transposeMultiplyMatrixL
x          transposeMultiplyMatrixL
  x          transposeMultiplyMatrixL
    x          transposeMultiplyMatrixL
[...]
Top functions accessing the object (#access, function):
6472048 99.90% transposeMultiplyMatrixL
[...]
```

Each `x` represents a load to the object. Each `*` represents a store to the object. Each column represents a thread. As we can see on this excerpt, the object is read and written by a single thread at the beginning of the execution. Then multiple threads access it in read only mode. The accesses are mostly done from the

`transposeMultiplyMatrixL` function. Note that this is a very raw output of the OEF. It is possible to automatize the analysis of the OEF, e.g., to know if an object has been written during a period of time.

Analyzing the OEF. The OEF shows two facts: one object represents 90% of all remote memory accesses and this object is initialized by one thread and then accessed in read-only by multiple threads. The best optimization in this case is to replicate the object on all nodes and make sure that threads use a local replica. MemProf tells us where the object is allocated, where it is initialized and where it is used. This information is sufficient to implement replication properly.

4.5 Conclusion

In this chapter, we have presented MemProf. MemProf builds flows of interactions between threads and objects. For each thread, MemProf builds a Thread Event Flow (TEF) that contains the memory accesses performed by the thread. For each object, MemProf builds an Object Event Flow (OEF) that contains the list of memory accesses performed to the object. We have used MemProf on FaceRec, a facial recognition application. We have explained how to analyze the Object Events Flows of FaceRec. We have shown that the object that represents 90% of all remote memory accesses of FaceRec can be replicated.



Evaluation

Contents

5.1	FaceRec	53
5.2	Streamcluster	55
5.3	Psearchy	57
5.4	Apache/PHP	58
5.5	Overhead	60
5.6	Conclusion	61

In this Chapter, we evaluate MemProf using four applications: FaceRec, Streamcluster, Apache and Psearchy on the three machines presented in Section 1.4. The first three applications perform a significant number of remote memory accesses. The last one performs fewer remote memory accesses but is memory-intensive. For each application, we first try to optimize the application using the output of existing profilers, i.e., instruction-oriented profilers like Perf and data-oriented profilers like Memphis. We show that the latter do not give precise insights on what and how to optimize the application. We then profile the application with MemProf and show that it allows precisely pinpointing the causes of remote memory accesses and designing appropriate optimizations to mitigate them. These optimizations are very simple (less than 10 lines of code) and efficient on all machines presented in Section 1.4 (the gains range from 6.5% to 161%). Finally, we conclude this chapter by a study of the overhead induced by MemProf.

5.1 FaceRec

FaceRec is a facial recognition engine of the ALPBench benchmark suite [60]. We use the default workload included in the suite. FaceRec performs 63% of its memory accesses on remote memory. We first try to optimize FaceRec using existing profilers.

We obtain a performance improvement ranging from 9% to 15%. We then try to optimize FaceRec using MemProf. We obtain a performance improvement ranging from 16% to 41%.

Optimization using existing profilers. Instruction-oriented profilers allow understanding that most remote memory accesses are performed in one function (see the output of the Perf profiler, presented in Table 5.1). This function takes two matrices as arguments and performs a matrix multiplication. It is called on all matrices manipulated by the application (using MemProf, we learn that 193 matrices are allocated during a run of the default ALPBench workload). Instruction-oriented profilers do not allow determining which matrices induce large numbers of remote memory accesses.

% of total remote accesses	Function
98	transposeMultiplyMatrixL
0.08	malloc

Table 5.1 – Functions performing most remote memory accesses in FaceRec.

Data-oriented profilers show that no remote memory access is performed on global statically allocated objects. Moreover, they allow gathering the list of virtual addresses that are accessed remotely, together with the ratio of remote memory accesses that each virtual address accounts for. Nevertheless, it is not possible to determine if a range of accessed addresses represents one or more matrices. Indeed, FaceRec allocates matrices of different sizes, and each range of virtual addresses can be used to store different matrices during different time intervals (MemProf actually shows that FaceRec allocates several matrices on the same virtual address ranges). Consequently, existing profilers do not allow understanding which matrices induce many remote memory accesses.

The optimizations that can be envisioned using the output of existing profilers are: (i) duplicating all matrices on all nodes, or (ii) interleaving the memory allocated for all matrices on all nodes. Both optimizations require the developer to retrieve all places in the code where matrices are allocated. We did not implement the first optimization because it requires writing complex code to synchronize the state of matrices whenever they are updated. Moreover, we know (using MemProf) that this optimization will not induce good performance. Indeed, MemProf shows that some matrices are often updated, and thus that the synchronization code would be frequently triggered. We tried the second optimization, which is simple to implement: it consists in replacing the calls to `malloc` with calls to `numa_alloc_interleaved`. This optimization induces performance improvements of 15%, 9% and 13% on Machines A, B and C respectively. Note that this optimization increases the number of remote memory accesses, but decreases the contention on one of the memory nodes, hence the performance improvement.

Optimization using MemProf. MemProf points out that most remote memory accesses are performed on a single matrix (see Table 5.2). This explains why the optimization presented in the previous paragraph induced a performance improvement: it decreases the contention on the memory node hosting this matrix. Using the OEF of this matrix, we observe that, contrarily to some other matrices, this matrix is written only

once and then accessed in read-only mode by a set of threads¹. The detailed analysis of the OEF was presented in Section 4.4.

We leverage this observation as follows: we optimize FaceRec by duplicating this matrix on all nodes after its initialization. As the matrix is never updated, we did not have to write any synchronization code. The matrix occupies 15MB of memory. The footprint overhead of this optimization is thus 45MB on machines A and B (4 nodes) and 105MB on machine C (8 nodes). The implementation of the matrix duplication only required 10 lines of code. We simply had to modify the `readAndProjectImages` function that initializes this matrix so that it allocates one matrix per node. For simplicity, we stored the various pointers to the matrices in a global array. Threads then choose the appropriate matrix depending on the node they are currently running on. With this optimization, FaceRec only performs 2.2% of its memory accesses on remote memory (63% before the optimization). This results in performance improvements of respectively 41%, 26% and 37% on Machines A, B and C.

% of total remote accesses	Object
98.8	s->basis(csuCommonSubspace.c:455)
0.2	[static objects of libc-2.11.2.so]

Table 5.2 – Objects remotely accessed in FaceRec.

5.2 Streamcluster

Streamcluster is a parallel data-mining application included in the popular PARSEC 2.0 benchmark suite [61]. Streamcluster performs 75% of its memory accesses on remote memory. We first try to optimize Streamcluster using existing profilers and obtain a performance improvement ranging from 33% to 136%. We then try to optimize Streamcluster using MemProf and obtain an improvement ranging from 37% to 161%. This means that Streamcluster is an application for which existing profilers provide enough information to successfully optimize the application, but that MemProf is able to provide details that can be exploited to implement the optimization slightly more efficiently.

Optimization using existing profilers. Instruction-oriented profilers allow understanding that most remote memory accesses are performed in one function (see the output of the Perf profiler, presented in Table 5.3). This function takes two points as parameters (`p1` and `p2`) and computes the distance between them. The following line of code does remote accesses:

```
result += (p1.coord[i]-p2.coord[i])*(p1.coord[i]-p2.coord[i]).
```

An analysis of the assembly code shows that remote memory accesses are performed on the `COORD` field of the points. It is nevertheless not possible to know if all points or only part of them induce remote memory accesses. Instruction-oriented profilers also allow understanding that one of the memory nodes is more loaded than others (i.e., memory accesses

¹As MemProf only samples a subset of the memory accesses, we checked this fact via source code inspection.

targeting this node have a higher latency).

% of total remote accesses	Function
80	dist
18	pspeedy
1	parsec_barrier_wait

Table 5.3 – Functions performing most remote memory accesses in Streamcluster.

Data-oriented profilers show that less than 1% of the remote memory accesses are performed on global statically allocated data. Moreover, they show that threads remotely access the same memory pages. This information is not sufficient to understand if some “points” are more frequently remotely accessed than others (as was the case with matrices in the FaceRec application), nor to understand if threads share data, or if they access different objects placed on the same page.

Several optimizations can be proposed: (i) memory duplication, (ii) memory migration, or (iii) memory interleaving. The first one performs poorly if objects are frequently updated. The second one performs poorly if various threads simultaneously access objects. As we have no information on these two points, and due to the fact that these two optimizations are complex to implement, we did not try them. The third possible optimization makes sense because one node of the system is saturated. Interleaving the memory allows spreading the load of memory accesses on all memory nodes, which avoids saturating nodes. The optimization works as follows: we interleave all the dynamically allocated memory pages thanks to the `numactl` utility available in recent Linux distributions. With this optimization, Streamcluster performs 80% of its memory accesses on remote memory (75% before optimizing), but memory accesses are evenly distributed on all nodes. This optimization improves performance by respectively 33%, 136% and 71% on Machines A, B and C.

Optimization using MemProf. MemProf shows that most remote memory accesses are performed on one array (see Table 5.4). Note that a set of objects accounts for 14% of remote memory accesses, but they are not represented in Table 5.4, as each object individually accounts for less than 0.5% of all remote memory accesses. The analysis of the OEF of the array shows that it is simultaneously read and written by many threads. The reason why MemProf allows pinpointing an array, whereas existing profilers point out the `coord` fields is simple: the `coord` fields of the different points are pointers to offsets within a single array (named “block” in Table 5.4). MemProf also outputs that the array is allocated on a single node, and that the latency of memory accesses to this node is very high (for instance, approximately 700 cycles on Machine B). Consequently, to optimize Streamcluster, we chose to interleave the memory allocated for this array on multiple nodes. This improves performance by respectively 37%, 161% and 82% for Machines A, B and C. As expected, this optimization does not decrease the ratio of remote memory accesses (75%), but it drastically reduces the average memory latency to the saturated node (430 cycles on Machine B). Note that, using MemProf, the optimization is more efficient: this comes from the fact that only a subset of the memory is interleaved: the memory that is effectively the target of remote memory

accesses.

It is important to note that MemProf also gives information about the potential benefits of the memory duplication and memory migration techniques discussed above. Indeed, MemProf shows that the array is frequently updated (i.e., there is a high ratio of write accesses), which indicates that memory duplication would probably perform poorly. Moreover, the analysis of the OEF of the array shows that several threads simultaneously access it, which indicates that memory migration would also probably perform poorly.

% of total remote accesses	Object
80.9	float *block(streamcluster.cpp:1852)
4.1	points.p(streamcluster.cpp:1865)
1	[stack]

Table 5.4 – Objects remotely accessed in Streamcluster.

5.3 Psearchy

Psearchy is a parallel file indexer from the Mosbench benchmark suite [46]. Psearchy only performs 17% of its memory accesses on remote memory but it is memory intensive: it exhibits a high ratio of memory accesses per instruction. We first try to optimize Psearchy using existing profilers and do not obtain any performance gain (the only straightforward optimization to implement yields a 14-29% performance decrease). We then try to optimize Psearchy using MemProf and obtain a performance improvement ranging from 6.5% to 8.2%.

Optimization using existing profilers. Instruction-oriented profilers allow finding the functions that perform most remote memory accesses (see the output of the Perf profiler, presented in Table 5.5). The first function, named `pass0`, aims at parsing the content of the files to be indexed. The second function is a sort function provided by the libc library. In both cases, we are not able to determine which objects are targeted by remote memory accesses. For instance, when looking at the assembly instructions that induce remote memory accesses in the `pass0` function, we are not able to determine if the memory accesses are performed on the file buffers, or on the structures that hold the indexed words. Indeed, the assembly instructions causing remote memory accesses are indirectly addressing registers and we are not able to infer the content of the registers by looking at the code.

Data-oriented profilers show that less than 1% of the remote memory accesses are performed on global statically allocated data. As in the case of FaceRec and Streamcluster, Data-oriented profilers show that threads access the same memory pages. We do thus consider the same set of optimizations: (i) memory duplication, (ii) memory migration, or (iii) memory interleaving. For the same reason as in Streamcluster, we do not try to apply the first two optimizations (the analysis performed with MemProf in the next paragraph validates this choice). The third possible optimization does not make sense either. Indeed, contrarily to what we observed

% of total remote accesses	Function
45	pass0
40	msort_with_tmp
7.7	strcmp
3	lookup

Table 5.5 – Functions performing remote memory accesses in Psearchy.

for Streamcluster, no memory node is saturated. As this optimization is very simple to implement, we nonetheless implemented it to make sure that it did not apply. It decreases the performance by respectively 22%, 14% and 29% for Machines A, B and C.

Optimization using MemProf. MemProf points out that most remote memory accesses are performed on many different objects. We also observe that these objects are of three different types. We give in Table 5.6 the percentage that each type of object accounts for with respect to the total number of remote memory accesses. More interestingly, we observe, using the OEFs of all objects, that each object is accessed by a single thread: the thread that allocated it. This means that threads in Psearchy do not share objects, contrarily to what we observed in FaceRec and Streamcluster². This observation is important for several reasons. First, it implies that memory duplication and memory migration are not suited to Psearchy. Second, it allows understanding why threads — although not sharing objects — all access the same memory pages: the reason is that all objects are allocated on the same set of memory pages. Using this information, it is trivial to propose a very simple optimization: forcing threads to allocate memory on the node where they run. As threads are not sharing objects, this should avoid most remote memory accesses. We implemented this optimization using the `numa_alloc_local` function. With this optimization, less than 2% of memory accesses are performed on remote objects and the performance increases by respectively 8.2%, 7.2% and 6.5% on Machines A, B and C.

% of total remote accesses	Type of object
42	ps.table(pedsort.C:614)
38	tmp(qsort_r+0x86)
10	ps.blocks(pedsort.C:620)

Table 5.6 – Types of the main objects that are remotely accessed in Psearchy.

5.4 Apache/PHP

Apache/PHP [47] is a widely used Web server stack. We benchmark it using the Specweb2005 [62] workload. Because machines B and C have a limited number of

²As MemProf only samples a subset of the memory accesses, we checked this fact via source code inspection.

network interfaces, we could not use them to benchmark the Apache/PHP stack under high load. On machine A, we observe that the Apache/PHP stack performs 75% of its memory accesses on remote memory. We first try to optimize the Apache/PHP stack using the output of existing profilers. We show that we are not able to precisely detect the cause of remote memory accesses, and that, consequently, all our optimizations fail. We then try to optimize the Apache/PHP stack using MemProf. We show that MemProf allows precisely pinpointing the two types of objects responsible for most remote memory accesses. Using a simple optimization (less than 10 lines of code), we improve the performance by up to 20%.

Optimization using existing profilers. Instruction-oriented profilers allow finding the functions that perform most remote memory accesses (see the output of the Perf profiler, presented in Table 5.7). No function stands out. The top functions are related to memory operations (e.g., `memcpy` copies memory zones) and they are called from many different places on many different variables. It is impossible to know what they access in memory.

% of total remote accesses	Function
5.18	<code>memcpy</code>
2.80	<code>_zend_mm_alloc_int</code>
1.72	<code>zend_hash_find</code>

Table 5.7 – Top functions performing remote memory accesses in the Apache/PHP stack.

Data-oriented profilers show that less than 4% of the remote memory accesses are performed on global statically allocated data. They also show that many threads remotely access the same set of memory pages. Finally, they show that some pages are accessed at different time intervals by different threads, whereas other pages are simultaneously accessed by multiple threads.

Several optimizations can be tried on Apache/PHP, based on the previously described observations. The first observation we tried to leverage is the fact that some pages are accessed at different time intervals by different threads. Because we did not know which objects are accessed, we designed an application-agnostic heuristic in charge of migrating pages. We used the same heuristic as the one recently described by Blagodurov et al. [4]: every 10ms a daemon wakes up and migrates pages. More precisely, the daemon sets up IBS sampling, “*reads the next sample and migrates the page containing the memory address in the sample along with K pages in the application address space that sequentially precede and follow the accessed page*”. In [4], the value of K is 4096. Unfortunately, using this heuristic, we observed a slight decrease in performance (around 5%). We tried different values for K, but without success. This is probably due to the fact that we use a different software configuration, with many more threads spawned by Apache.

The second observation we tried to leverage is the fact that some pages are simultaneously accessed by multiple threads. As we did not expect Apache threads to share memory pages (each thread is in charge of one TCP connection and handles

a dedicated HTTP request stream), we thought there could be a memory allocation problem similar to the one encountered in Psearchy, where threads allocate data on a remote node. We did thus try to use a NUMA-aware memory allocator, i.e., we replaced all calls to `malloc` with calls to `numa_alloc_local`. This did not impact the performance. Although no memory node was overloaded, we also tried to interleave the memory using the `numactl` utility. This optimization did not impact the performance either. Finally, we thought that the problem could be due to threads migrating from one memory node to another one, thus causing remote memory accesses. Consequently, we decided to pin all Apache threads and all PHP processes at creation time on the different available cores, using a round-robin strategy. To pin threads and processes we used the `pthread_set_affinity` function. This optimization had a negligible impact on performance (2% improvement).

Optimization using MemProf. MemProf points out that Apache performs most of its remote memory accesses on two types of objects: variables named `apr_pools`, that are all allocated in a single function, and the pointer relocation table (PLT). The PLT is a special section of binaries mapped in memory. It is used at runtime to store the virtual address of the library functions used by the binary, such as the the virtual address of the `memcpy` function. Using the OEF of the PLT and of the `apr_pools` objects, we found that each of these objects is shared between a set of threads belonging to a same process. Consequently, we decided to optimize Apache/PHP by pinning all threads belonging to the same Apache processes on the same node. This modification requires less than 10 lines of code and induces a 19.7% performance improvement. This performance improvement is explained by the fact that the optimization drastically reduces the ratio of remote memory accesses. Using this optimization, the Apache/PHP stack performs 10% of its memory accesses on remote memory (75% before optimization).

5.5 Overhead

In this section, we study the overhead and accuracy of MemProf. Note that our observations apply to our three test machines.

The main source of overhead introduced by MemProf is IBS sampling, whose rate is configurable. In order to obtain precise results, we adjust the rate to collect at least 10k samples of instructions accessing DRAM. For most of the applications that we have observed, this translates into configuring IBS with a frequency that is less than one interrupt every 60K cycles, which causes a 5% slowdown. For applications that run for a short period of time or make few DRAM accesses, it may be necessary to increase the sampling rate. In all the applications that we studied, we found it unnecessary to go beyond a sampling rate of one IBS interrupt every 20k cycles, which induces a 20% slowdown (the application lasts less than 0.5s, hence the high sampling rate).

The costs of IBS processing can be detailed as follows. Discarding a sample (for instructions that do not access DRAM) takes 700 cycles while storing a relevant sample in a per-CPU buffer requires 2.7k cycles. The storage of samples is currently not heavily optimized. A batch of 10k samples requires 2MB and we pre-allocate up to 5% of the machine RAM for the buffers, which has proven acceptable constraints in practice.

The second source of overhead in MemProf is the tracking of the lifecycles of

memory objects and threads performed by the user library and the kernel module. The interception of a lifecycle event and its online processing by the user library requires 400 cycles. This tracking introduces a negligible slowdown on the applications that we have studied. The storage of 10k events requires 5.9MB in user buffers, for which we pre-allocate 20MB of the machine RAM. The processing and storage overheads induced by the kernel-level tracking are significantly lower.

Finally, the offline processing (required to build OEFs and TEFs) for a MemProf trace corresponding to a 1-minute application run takes approximately 5 seconds.

5.6 Conclusion

We have evaluated MemProf on 4 applications. MemProf was systematically able to identify the causes of remote memory accesses and help us to find simple and efficient solutions. With lightweight modifications to the source code of the applications (less than 10 lines of code), we were able to achieve significant performance improvements (up to x2.6).

Part II

Carrefour - Dynamic memory management on NUMA multicore machines



Motivation

Contents

6.1 MemProf vs. dynamic memory management algorithms, advantages and constraints of live diagnosis	66
6.2 Existing static and dynamic memory algorithms	67
6.2.1 Works done on UMA systems	67
6.2.2 Linux - “First touch” and “interleave” allocation policies .	67
6.2.3 Solaris and Windows - Home node	68
6.2.4 AutoNUMA	68
6.2.5 Verghese et al. - ASPLOS’96	68
6.2.6 DINO	69
6.2.7 Thread Clustering	70
6.2.8 Affinity Accept	70
6.3 Limitations of existing dynamic memory management algorithms	70
6.4 Conclusion	71

In the first part, we have presented MemProf. MemProf allows finding and implementing simple and efficient memory optimizations. In this chapter, we describe existing dynamic memory management algorithms. Dynamic memory management algorithms run along applications and try to optimize their memory accesses automatically. We first explain the advantages and constraints of dynamic memory management over profiling. Then we present the main algorithms currently used to manage memory in NUMA systems. We conclude this chapter with an overview of the limitations of existing algorithms.

6.1 MemProf vs. dynamic memory management algorithms, advantages and constraints of live diagnosis

In the first part, we have seen how to find and fix NUMA-related issues using MemProf. Most of the optimizations that were presented in this part are easy to implement, so one might wonder if developing a new a dynamic memory management algorithm is really useful. In this section, we try to answer this question and to explain the advantages and constraints of dynamic memory management algorithms.

Limitations of profiling and advantages of dynamic memory management heuristics. MemProf cannot be used in all situations. The main drawback of using MemProf is that it requires time, some expertise and access to the source code of the application to implement a solution. Indeed, currently MemProf does not automatically provide any all-inclusive solution to patch applications that suffer from NUMA issues. Optimizations have to be manually implemented using information provided by MemProf.

Another drawback of manual optimizations is that they might be difficult to implement on applications that have hard-to-predict memory access patterns, e.g., applications whose memory accesses depend on the workload, like databases. Optimizations might also be hard to implement when remote memory accesses are not performed on few objects by few functions (as it was the case in the 4 applications used in the evaluation of MemProf).

Finally, manual optimizations can only be tested on a limited set of machines. The bottlenecks of an application may vary depending on the hardware it is executing on or depending on whether or not the application is co-scheduled with other applications [4]. If the bottlenecks change, so do the optimizations required to circumvent these bottlenecks. Consequently, manual optimizations work best in "HPC-like" environments in which the exact context of execution of all applications is well known.

Dynamic memory management algorithms, on the contrary, do not suffer from these drawbacks: optimizations are applied automatically, without requiring the source code of applications; they adapt to workload changes and often work on multiple machines and execution contexts. Even in situations where the context of execution is perfectly controlled, dynamic memory management techniques might work better than manual optimizations because they try to optimize *all* memory accesses – i.e., not only the memory accesses done to the most accessed objects like manual optimizations do.

Limitations of dynamic memory management heuristics. Dynamic memory management algorithms also have limitations. The main difficulty in dynamic memory management is to try to predict what will happen in the future of the application's execution based on what the application did in the past. This may not work if the memory access patterns of the application frequently change. Using profiling, a developer has a complete view of the execution of the application and may be able to detect that the memory access patterns change over the application lifetime, and thus implement an appropriate optimization.

The second limitation of dynamic memory management algorithms is the granularity of observations. Because observations have to be made with low overhead, all existing

algorithms work (i) on average memory access statistics at the granularity of cache lines or larger and (ii) consider applications as black boxes (i.e., they do not try to link memory accesses with objects allocated by the application or functions of the application). In some situations, coarse-grain observations might prevent the algorithm from choosing the best optimization, e.g., an algorithm might think that two threads share data, while they are accessing different objects located in the same memory page or in the same cache line. Because costly analysis can be performed offline with a profiler, a profiler can report much more precise information about memory accesses than dynamic algorithms.

Conclusion. Profiling and dynamic algorithms are not really conflicting approaches. Both have advantages and drawbacks. Profiling shines to understand complex memory access patterns, while dynamic algorithms can be used on most applications to automatically improve performance effortlessly.

6.2 Existing static and dynamic memory algorithms

6.2.1 Works done on UMA systems

Before NUMA systems became commonplace, dynamic memory management algorithms have been developed for UMA systems. Implemented heuristics focus on improving the cache hit ratio.

Most of these heuristics rely on judicious thread placement to perform this task. For instance, Boyd et al. [6] migrate threads close to the caches that contain data they use, Tam et al. [7] try to improve cache efficiency by migrating threads that share data on cores sharing a cache, and the works described in [8, 13, 63, 64] place threads on cores so as to limit contention on shared caches (i.e., in order to limit *cache trashing*).

Because data located in cache is volatile and often change, few people have focused on memory placement to improve cache efficiency. One notable exception is the work by Kessler et al. [65]. The key idea behind this work is to force different application to use different cache lines. This reduces the number of cache lines that a single application may use, but eliminates cache trashing between applications. In order to force applications to use different cache lines, Kessler et al. use a technique known as “page coloring”. Each page is given a color that corresponds to the cache lines it is mapped to. The kernel then attributes different colors to different applications. An application can only allocate pages of its color.

Some of the ideas used by these heuristics still make sense on NUMA systems. However, in most cases, as identified by Blagodurov et al. [23], these heuristics may hurt performance on NUMA systems because they create additional contention of interconnects and memory buses.

6.2.2 Linux - “First touch” and “interleave” allocation policies

By default, Linux uses the “first touch” allocation policy: pages are allocated on the node from which they are first accessed. This node may be different from the node on which the `malloc` call was performed. The objective of first touch allocation is to improve the co-location of threads and data. If a data is accessed from a single

node, then it will be accessed locally. This strategy improves locality when threads located on different nodes share little data and when threads are not often migrated between nodes. Linux can also be configured to interleave pages between nodes, but this configuration has to be made manually by a developer: Linux does not provide any dynamic algorithm to switch between the “first touch” and the “interleave” allocation policies. In the evaluation (Chapter 8), we use the first touch allocation policy (default Linux behavior) as the performance baseline.

6.2.3 Solaris and Windows - Home node

Solaris and Windows use the same allocation policy called the “home node” policy [66, 67]. The kernel attributes a “home node” to each application. The “home node” has two main purposes: (i) when an application performs a memory allocation, data is preferably allocated on the home node of the application and (ii) threads of an application are preferably scheduled on the home node of the application. The home node policy works best when threads of different applications can be clustered on different nodes without creating CPU idleness. However, this policy can create contention for multi-threaded application, because all memory tends to be allocated on a single node.

6.2.4 AutoNUMA

AutoNUMA is a recent patch for Linux kernels [9]. It is currently not merged in the main kernel branch but is likely to be in the years to come. AutoNUMA uses two main techniques: it performs thread migrations and memory migrations. The idea behind AutoNUMA is to migrate threads on the node they access the most and pages on the node from which they are the most accessed. Thus, AutoNUMA focuses on improving the locality of memory accesses.

Memory accesses are determined using page fault statistics. Periodically a daemon unmaps pages. When these pages are accessed, page faults occur, allowing AutoNUMA to compute statistics on threads and page locations. When a page induces two page-faults in a row from the same node, the page is migrated to the node.

The main limitation of AutoNUMA is that it does not consider workloads with data sharing: if a page is accessed from multiples nodes, then it is either migrated constantly between nodes (which creates unnecessarily overhead) or it is ignored by the algorithm.

6.2.5 Verghese et al. - ASPLOS’96

In [5], Verghese et al. present a dynamic memory management algorithm for cache-coherent NUMA machines. Their algorithm uses page migration and page replication to improve locality. Figure 6.1 represents the 3 steps of the algorithm. First, only “hot pages” are considered for migration and replication. A page is considered hot if the number of memory accesses done to the page exceeds a threshold. The threshold used in the paper depends on the application. Then, if a single thread accesses the page and few pages have already been migrated, the page is migrated. The number of “already migrated pages” is taken into account in order to limit the overhead of the algorithm. If the page is shared, never written, and the machine still has free memory,

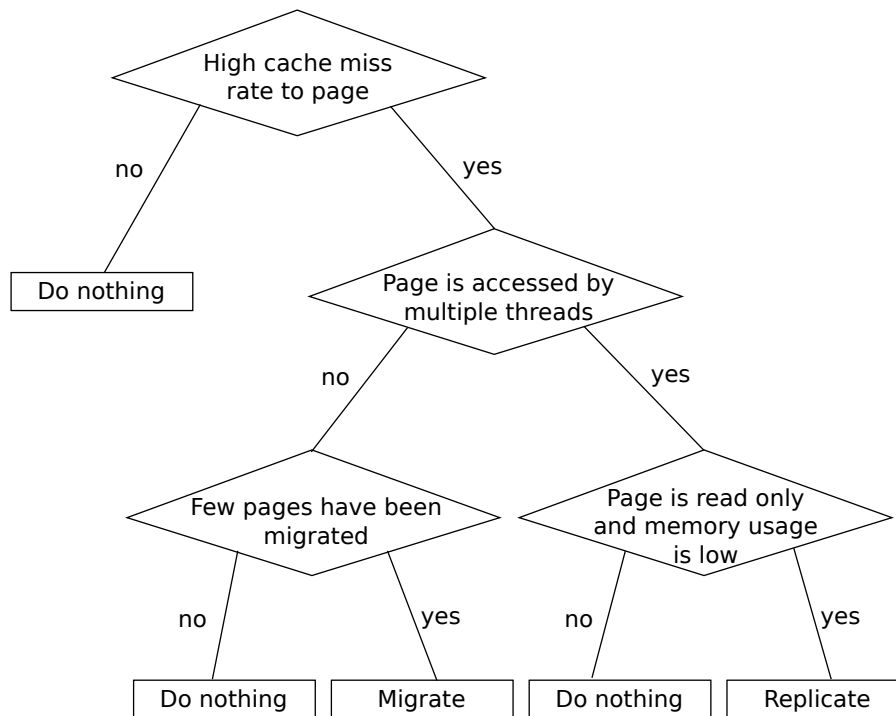

Figure 6.1 – Algorithm used by Verghese et al. [5]. This decision tree is applied on all pages accessed in memory.

then the page is replicated. The authors rely on special hardware support to monitor the memory accesses performed by applications (i.e., a hardware module that counts memory accesses performed to each page by each node). The goal of this algorithm is to increase the locality of memory accesses but the authors note that, as a side effect, the algorithm may also reduce contention. However, contention is not taken into account in their algorithm.

6.2.6 DINO

DINO [4] is a recent algorithm that aims at reducing contention on NUMA systems. The objective of the algorithm is to minimize cache contention while avoiding interconnect and memory controller contention. DINO works by spreading threads that perform a lot of memory accesses on different NUMA nodes. The algorithm tries to minimize the global cache miss rate by migrating threads. When a thread is migrated, DINO also migrates part of its working set. The working set of a thread is determined using IBS. The authors note that thread migrations have to be done infrequently in order to avoid contention on interconnect links due to page migrations.

This work was mainly designed to improve performance of multi-application workloads in which all threads of an application can be clustered on the same NUMA node. Thus, DINO does not address data sharing from multiple nodes. If multiple nodes access a page, then the page might be migrated multiple times.

6.2.7 Thread Clustering

Thread Clustering [7] is an algorithm designed for UMA systems. The key idea behind thread clustering is to co-locate (*cluster*) threads that share data on cores sharing a cache. The authors mention that the algorithm can be “trivially” extended to NUMA systems (i.e., most likely by clustering threads that share data on the same NUMA node). The algorithm measures the “similarity” of memory accesses performed by distinct threads using hardware facilities available in PowerPC processors. An equivalent computation can be performed on AMD processors using IBS or on Intel processors using PEBS. The algorithm compares accesses to cache lines and cluster threads that access the same cache lines. The algorithm only clusters threads when clusters do not create CPU idleness.

Note that, since Thread Clustering was designed for UMA systems, the authors do not explain precisely how clusters would be placed on NUMA nodes (i.e., on the node that is the most accessed by the cluster?) or if they would use memory migration to place memory close to the threads accessing them.

The main limitation of Thread Clustering is that it was designed for workloads where clusters of threads could be created without creating idleness. For instance, Thread Clustering will not cluster two threads on the same core if it leaves another core idle. Consequently Thread Clustering does not do anything on workloads composed of a single multi-threaded application in which all threads share data.

6.2.8 Affinity Accept

Affinity-Accept is a recent evolution of the TCP stack for NUMA machines [10]. The objective of Affinity-Accept is to improve the locality of TCP connections. In a system that runs Affinity-Accept, all computations induced by a single TCP connection (kernel computations and userland computations) are performed on a single core. When a new connection is established, Affinity-Accept chooses a core responsible for the computations associated with the TCP connection depending on the current load of cores.

Affinity-Accept only improves locality of workloads that do network processing.

6.3 Limitations of existing dynamic memory management algorithms

As we have seen in the previous section, multiple heuristics have been designed to manage memory on UMA and NUMA systems. Most of these heuristics focus on improving the locality of memory accesses, but none focuses on contention. This is an important limitation of existing heuristics: as we have seen in Section 1.5.3, contention on interconnects and memory buses has a higher impact on performance than remote memory accesses.

For example, no algorithm addresses the problem of data that is read and written by a large number of threads spread across multiple NUMA nodes. Algorithms based on thread placement would either take no decision or place all threads on a single NUMA node – which would result in CPU idleness and degrade performance. Algorithm based on memory placement will not try to change memory placement. Even DINO, that takes

contention issues into account, only acts on thread and memory placement if locality can be improved. Consequently, these algorithms fail to address workloads that suffer from contention but in which locality cannot be improved. This limitation, in practice, prevents current algorithms from working on a wide range of applications. Table 6.1 presents a summary of existing techniques and their limitations three applications: Streamcluster, FaceRec and FT from the NAS benchmark. In Streamcluster, all threads read and write an array. In FaceRec, all threads read an array. In FT, threads mainly manipulate their own data (the locality cannot be improved and memory should not be migrated). As we can see, no algorithm is able to improve performance in all situations. Some algorithms even degrade performance (e.g., the “home node” algorithm on FT) because they create additional contention. The algorithm that seems to give the best performance is that from Verghese et al. described in Section 6.2.4. Unfortunately this algorithm does not handle pages shared in read/write mode and thus does not improve the performance of Streamcluster. Also note that this algorithm has to be manually tuned for all applications and that it relies on special hardware support to work (i.e., a hardware module that counts memory accesses performed to each page by each node).

6.4 Conclusion

In this chapter, we have seen that profiling and dynamic memory management algorithms are not antagonistic approaches. We have explained that dynamic memory management algorithms are useful in a wide variety of situations – e.g., when the context of execution of applications cannot be known in advance or when the source code of applications is not available. As we have seen in this chapter, currently no algorithm works (i) automatically and (ii) systematically on all applications. The main reason is that current algorithms solely focus on locality and fail to tackle contention, even though the impact of contention on current NUMA system is higher than that of locality (see Section 1.5.3).

Optimization Workload	Asplos'96 [5]	AutoNUMA [9]	Thread Clustering [7]	DINO [4]	Affinity-accept [10]	Home node	Manual interleaving
Streamcluster (Best optimization: interleave an array)	× does nothing (memory is accessed in R/W and locality cannot be improved)	≈ will migrate some pages but not balance the load ideally	× does nothing (clustering would create idleness)	× will not take any decision (no thread migration)	× does nothing (no I/O)	× will not change contention	≈ suboptimal (will interleave objects that should not be interleaved)
FaceRec (Best optimization: replicate a matrix)	✓	≈ will migrate some pages but not replicate any page	× does nothing (clustering would create idleness)	× will not take any decision (no thread migration)	× does nothing (no I/O)	× will not change contention	≈ suboptimal (locality would be 25% instead of 100%)
FT (Best optimization: do nothing)	✓ does nothing (Locality cannot be improved)	× Degrades performance because of unnecessary migrations	✓ does nothing (clustering would create idleness)	✓ will not take any decision (no thread migration)	✓ does nothing (no I/O)	× will create contention	× degrades performance because it degrades locality

Table 6.1 – Summary of optimizations and reason why they do not work in some workloads.



Carrefour

Contents

7.1 Overview	74
7.2 Profiling	75
7.2.1 Global and per application metrics	75
7.2.2 Capturing interactions between threads and pages	76
7.3 Per application decisions	77
7.4 Per page decisions	78
7.5 Reducing the overhead	78
7.5.1 Reducing the overhead of capturing interactions between threads and pages	78
7.5.2 Avoiding bad per page decisions	80
7.6 Conclusion	80

In this chapter, we present Carrefour, the first memory management algorithm that aims at reducing contention on memory controllers and interconnect links. Carrefour was done as an international research collaboration with the systems group at SFU in Vancouver, Canada [1]. In this Chapter, I present my contributions to Carrefour. As we have seen in the previous chapter, memory management on UMA and NUMA systems has been studied for a long time, but existing memory management algorithms focus solely on improving locality. Carrefour takes a radically new approach by focusing first on reducing contention and *then* on improving locality. We begin this chapter with an overview of the goals of Carrefour and of the algorithm. Then, in the next three Sections, we detail the three main steps of the algorithm and explain how we managed to reduce their overhead. Carrefour code is available for download at the following url: <https://github.com/Carrefour>.

7.1 Overview

The workflow of Carrefour is pictured in Figure 7.1. Carrefour works in 3 main steps: (i) profiling to gather metrics and page accesses statistics, (ii) per application decisions, to decide whether to enable Carrefour for the applications and then whether to enable page migration, page replication or page interleaving, and (iii) per page decisions – actually migrating, replicating or interleaving pages. These three steps are described in detail in the next three sections.

Carrefour always runs in background. We make sure that it has as little overhead as possible. Two operations performed by Carrefour are costly: gathering pages accesses statistics and per page decisions (these operations are highlighted in bold in Figure 7.1).

Carrefour uses Hardware Counters to compute metrics and IBS to gather page accesses statistics. In theory all metrics could be computed using IBS only (as MemProf does), but this would require a high sampling rate to be accurate, and thus induce too much overhead [68]. Thus Carrefour uses Hardware Counters – that have a negligible overhead – to guide the decision process. Hardware Performance Counters are used to enable or to disable Carrefour and to decide whether migration, interleaving and replication make sense for a given application (e.g., if we detect that the write ratio is high, then Carrefour disables replication). Using these hints, Carrefour can take appropriate “per page” decisions, even with few IBS samples. For example, even if we do not see any write to a page, Carrefour will not replicate the page when the write ratio is high – we thus avoid taking risky decisions when they are likely to degrade performance.

The first step (*profiling*) runs continuously in background. Steps 2 and 3 run every second. Steps 2 and 3 use and reset statistics collected by step 1. We found experimentally that running steps 2 and 3 every second was the best way to take accurate decisions with little overhead. However, note that, as Table 7.1 shows, the period at which steps 2 and 3 run does not have to be set precisely: on Streamcluster, any period between 0.5s and 2s provides the same result.

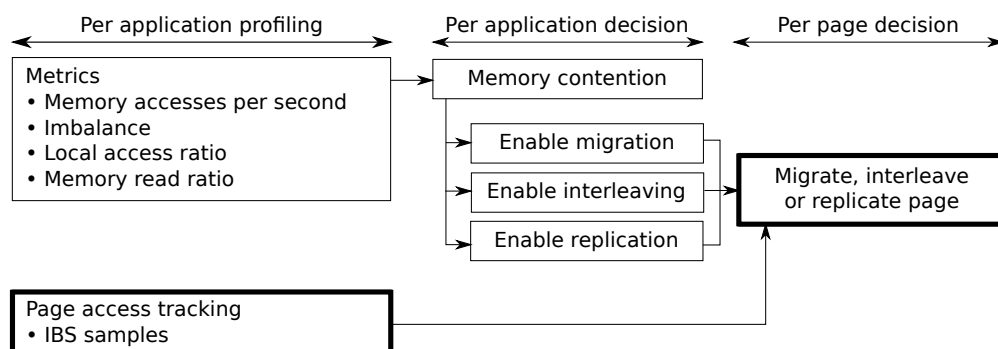

Figure 7.1 – Workflow of Carrefour. The two boxes in bold (IBS sampling and per page decisions) represent the costly parts of the workflow.

Period	Streamcluster Completion time
0.1s	66s
0.25s	64s
0.5s	63s
1s	63s
1.25s	63s
1.5s	63s
2s	63s
3s	65s
5s	69s

Table 7.1 – Influence of the period at which Carrefour runs on the performance of Streamcluster.

7.2 Profiling

7.2.1 Global and per application metrics

Carrefour uses Hardware Performance Counters and kernel statistics to collect global and per application metrics. These metrics are used by Carrefour to enable or disable migration, interleaving and replication on a per application basis. The goal of using these metrics and the decision process is detailed in Section 7.3.

The full list of metrics collected by Carrefour is presented in Table 7.2 (a). Current Opteron processors can only monitor up to 4 Hardware Counters at the same time, so Carrefour tries to compute all the metrics using as few Hardware Counters as possible to limit the multiplexing of counters. Carrefour computes 5 metrics that we detail in turn:

- **MAPTU.** The MAPTU represents the number of Memory Accesses Per Time Unit (per second in the case of Carrefour). It is calculated using time and event 0x1F0¹.
- **MC-IMB.** The MC-IMB represents the Memory Controller Imbalance. It is the standard deviation of the load across all memory controllers, expressed as percent of the mean. To calculate the imbalance, we re-use the same 0x1F0 event that was used to calculate the MAPTU.
- **MRR.** The Memory Read ratio represents the percentage of memory accesses that read memory (vs. memory accesses that write memory). The MMR is also computed using the 0x1F0 event because this event allows distinguishing read and write requests done to memory controllers.
- **LAR.** The Local Access Ratio is calculated using the 0x1E0 event. This event allows computing the number of memory accesses done from each node to each other node. To compute the LAR of a node, we divide the number of memory

¹Event 0x1F0 counts the number of memory accesses received by each memory controllers. It is monitored per node.

Global metrics	
MAPTU	Memory (DRAM) accesses per time unit (microsecond)
MC-IMB	Memory controller imbalance
LAR	Local access ratio
Per-application metrics	
MRR	Memory read ratio. Fraction of DRAM accesses that are reads
CPU%	Percent CPU utilization

(a)

Per-page metrics	
Number of accesses	The number of sampled data loads that fell in that page
Access type	Read-only or read-write

(b)

Table 7.2 – (a) Metrics collected using Hardware Counters and kernel statistics.
(b) Metrics collected using IBS.

accesses that this node performs to its local memory controller by the total number of memory accesses that it performs.

- **CPU%**. In order to compute the percent of CPU used by each application, Carrefour currently uses the `ps` command.

In order to collect these metrics, Carrefour configures hardware counters in counting mode. In counting mode, counters count the number of times the event they monitor occurs without generating any interrupt (see Section 3.1.1). The overhead of using HWC in counting mode is negligible: it consists in 1 MSR read per event per second (i.e., approximately 350 cycle per event per second).

7.2.2 Capturing interactions between threads and pages

In order to capture per page metrics (see Table 7.2 (b)), Carrefour uses IBS. Per page metrics represent one of the two main sources of overhead of Carrefour. Section 7.5.1 details how we configured IBS frequency in order to limit the overhead of Carrefour.

When an IBS interrupt occurs, Carrefour stores the following information: (i) the physical and virtual addresses of the page accessed by the sampled instruction, and (ii) a boolean indicating whether the access is a read or a write. This information is stored in a global red-black tree. The red-black tree is reset after each round of Carrefour. The red-black tree is indexed by the physical address of the accessed page. Carrefour relies on the assumption that a single physical address represents a single logical page in memory during one round. In practice, this assumption is not a problem for the workloads we consider: (i) no memory migration happens during the profiling phase of

Carrefour² and (ii) we do not consider cases in which the swap is used³.

Currently, Carrefour only stores a maximum of 30K different pages in the red-black tree. This number was chosen to limit the maximum number of migrations and replications that Carrefour could perform in a second. Note that working on 30K pages proved to be enough to balance load on all applications that we considered. The precise value of this number is also not important, as shown in Table 7.3. The main reason is that we use sampling to detect accessed pages. Pages that are frequently accessed in memory are more likely to be in the first 30K seen pages than other pages. Consequently, even if Carrefour does not consider all accessed pages, it is likely to work on the “hottest” ones.

Number of pages	Completion time
10K	66s
20K	63s
30K	63s
60K	63s

Table 7.3 – Influence of the number of pages considered by Carrefour on the performance of Streamcluster.

7.3 Per application decisions

Per application decisions is the second step of the Carrefour algorithm. This step runs every second. The first metric collected by Carrefour, the MAPTU, is used to estimate the likelihood of contention on the machine. If the MAPTU is high, then the global load on memory controllers is high. Note that the fact that the MAPTU be high is not a guarantee that contention occurs in the system. However, if the MAPTU is low, then we are sure that there is no contention on memory controllers (because the system is not memory intensive). So, Carrefour takes a pessimistic approach by guessing that contention *might* occur as soon as it sees memory accesses. If contention *cannot* occur, then Carrefour is deactivated.

Carrefour only considers applications that use more than 10% of a single CPU. This restriction was added to make sure that decisions taken by Carrefour would have a significant impact on the global machine’s performance: if an application uses less than 10% of a CPU, it is unlikely that it represents a significant portion of the contention of the machine. If an application uses more than 10% of a CPU and the MAPTU is high, then Carrefour is activated for the application.

Then Carrefour decides whether it is necessary to enable or disable migration, interleaving and replication. To this purpose, Carrefour uses the MC-IMB, the LAR and

²To the best of our knowledge, no widely deployed application currently performs memory migration. Note that special rules could easily be added in Carrefour to detect applications that handle memory placement on their own.

³In practice, not considering cases in which the swap is used is not a problem when the objective is to decrease memory contention: when the swap is used, the global bandwidth is often limited by the bandwidth of disks which is far lower than that of memory. Also note that using workloads that fit in memory is in line with current datacenters designs [18, 69].

the MRR. The algorithm was mainly designed by the SFU Team is not fully described in this thesis. The rationals behind the algorithms are simple. If the read ratio is low, then replication is likely to be harmful and so it is deactivated. If the LAR is high, then migrations are unlikely to improve performance, so migration is deactivated. The same reasoning is done for interleaving: if imbalance on memory controller is low, then interleaving is deactivated. The exact values of the thresholds can be found in [3]. The goal of enabling or disabling interleaving, migration or replication per application is to ensure that Carrefour will take as few “risky decisions” (i.e., decisions that could degrade performance) as possible. Thus, optimizations are deactivated in situations in which they are unlikely to improve performance.

7.4 Per page decisions

After deciding which techniques (i.e., migration, interleaving, replication) should be enabled for each application, Carrefour takes per page decisions (step 3 of the Carrefour workflow). A page can only be migrated, interleaved or replicated if migration, interleaving or replication - respectively - have been enabled for the application it belongs to. Carrefour then tries to choose the best available technique for each page.

Figure 7.2 pictures the per-page algorithm used by Carrefour. The algorithm is kept very simple: if the page has been accessed from one node, then it is migrated. If a page has been accessed by multiple nodes in read only mode, then it is replicated. Otherwise the page is “interleaved”: placed on a node that is less loaded than the node it is currently located on. The algorithm is similar to that used by Verghese et al. [5] but tries to balance the load in more cases.

This algorithm is applied on all pages accessed more than twice during the profiling phase of Carrefour. We eliminate pages accessed only once for two reasons: (i) migrating, interleaving and replication a page is costly, so we try to avoid performing these operations on pages that are infrequently accessed in memory, and (ii) 1 sample is not enough to take accurate decisions (e.g., it is not possible to know if a page is shared with only one sample). Two samples proved to be enough in practice to take accurate decisions, thanks to the “per application decisions” taken in step 2.

7.5 Reducing the overhead

In the three steps described in the previous sections, two operations are costly: capturing interactions between threads and pages and per page decisions. In this section we show how we limited the overhead of these two operations in turn.

7.5.1 Reducing the overhead of capturing interactions between threads and pages

The overhead of capturing interactions between threads and pages depends on the frequency of IBS: the more IBS interrupts are generated, the higher the overhead. The overhead has two main causes: the cost of handling IBS interrupts and the cost of recording IBS data. We use two techniques to limit the overhead of these two costs. We describe them below.

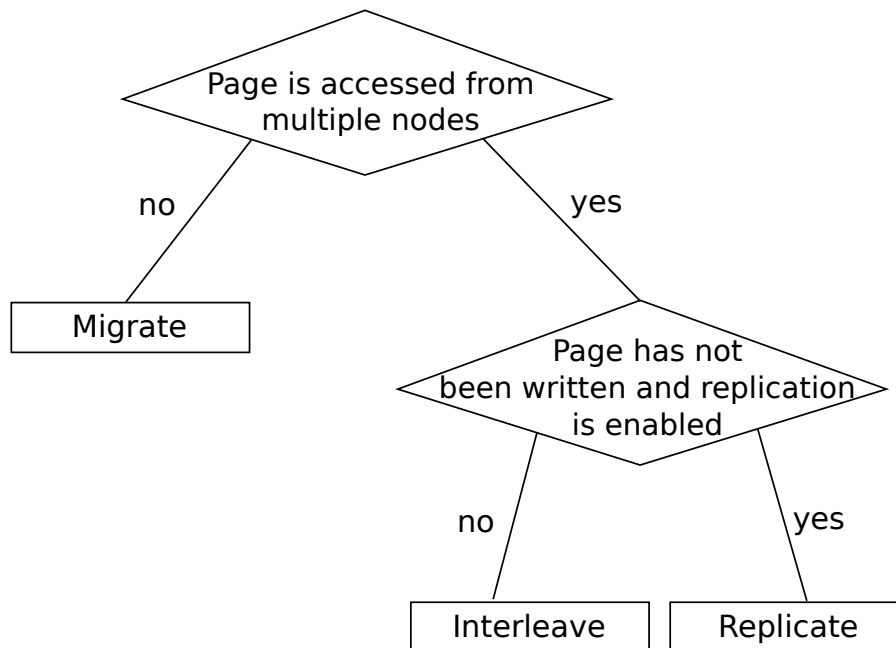

Figure 7.2 – Algorithm used by Carrefour. This decision tree is applied on all pages accessed in memory. The “Migrate” and “Interleave” boxes will only result in migrations or interleaving if migration or interleaving, respectively, are enabled.

Considering all IBS samples. Carrefour tries to optimize memory accesses performed to the DRAM. So, in theory, Carrefour should filter IBS samples to only compute statistics on instructions that access the DRAM. However, few IBS samples indicate a DRAM access and IBS has to be configured with a high sampling rate in order to have enough samples of instructions that access DRAM to perform meaningful analyses⁴. The first optimization consists in considering all IBS samples (i.e., even samples that hit in cache), to get more samples with a lower IBS frequency and thus with less interrupts. An unwanted side effect of this optimization is that Carrefour might migrate a page that is mostly accessed in cache. In practice we found that this is not an issue: Carrefour only works on applications that do a lot of memory accesses, and we found that, in these applications, pages that are frequently accessed in cache are most of the time also frequently accessed in memory. Also note that, since IBS does not consider accesses made by the prefetcher, considering data that IBS sees in cache is also a way to account for memory accesses done by the prefetcher.

Adapting IBS frequency. To reduce the overhead induced both by IBS interrupts and by recording of IBS data, we use an adaptive sampling rate. We start with a relatively high rate (1 IBS sample every 65K cycles). If after the step 3 we migrate, replicate or interleave less than 10 pages, then we reduce the sampling rate by 4. Otherwise we keep the sampling rate at 1 IBS sample every 65K cycles.

⁴As seen in Section 3.1.2 IBS cannot filter samples in hardware, so interrupts are generated for all instructions tagged by IBS. The probability that a random instruction miss in cache is low - usually caches have a hit rate that is more than 95%.

The key idea behind adapting the sampling rate is to reduce the overhead when we think that Carrefour is not required. On the one hand, if Carrefour takes no decision, then there is no point in capturing lots of interactions between threads and pages. On the other hand, if Carrefour takes decisions, then we want these decisions to be as accurate as possible – hence the high sampling rate. Our assumption is that the overhead induced by the sampling rate has a much lower impact on performance than the benefits of taking good memory placement decisions.

7.5.2 Avoiding bad per page decisions

These optimizations have been designed by the SFU Team; we briefly explain the ideas in this subsection. Per page decisions are costly. Table 7.4 details the cost of migrating (or interleaving) and replicating a page. Carrefour tries to take the “right” decisions per page, but because decisions are based on incomplete statistics, and because the workloads of the application may change, some of these decisions can degrade performance. We identified two kinds of “bad decisions” that could hurt performance.

Decision	Cost (in cycle)
Migrating a page	~ 5200
Replicating a page ⁵	~ 9000

Table 7.4 – Cost of per page decisions in Carrefour.

Ping-Pong effect. It is possible that during one round Carrefour sees that a page is accessed exclusively from one node (and thus decides to migrate the page on this node) and in the next round sees that the page is accessed from another node (and thus migrates it to the other node). We call the frequent migration of a page between nodes the “ping pong effect”. This could be due to inaccuracies in per page statistics (i.e., if a page is shared but we have too few samples to detect it) or because the workload of the application changes. In both cases, (i) constantly migrating pages between nodes is costly and (ii) the migrations do not seem to improve the locality of memory accesses. Carrefour detects such patterns and deactivates migration on a per page basis.

Avoiding replicating frequently written pages. Even on applications with a low write ratio, some pages are frequently written. Carrefour might decide to replicate these pages (i.e., because we use sampling, we may miss all writes to a page). If a page has been frequently marked for replication and then written, then we permanently disable replication for this page.

7.6 Conclusion

In this chapter, we have seen how Carrefour dynamically changes memory placement to limit contention and improve locality on NUMA machines. Carrefour relies

⁵This cost only comprises the cost of duplicating the page table entries. It does not comprises the cost of actually copying the page content on multiple nodes - this operation is performed lazily and depends on the number of nodes that access the page.

on Hardware Counters and IBS to track memory accesses and to choose between optimizations. Carrefour first estimates the contention on the machine and then enables migration, interleaving and/or replication for each application. We have seen that gathering this information is costly and that Carrefour tries to limit its overhead by adjusting the IBS sampling frequency. We have also seen how Carrefour mitigates the effect of bad per page decisions by avoiding ping-pong effects and avoiding replicating frequently written pages.



Evaluation

Contents

8.1	Single-application workloads	83
8.1.1	Performance comparison	83
8.1.2	Performance analysis	84
8.1.3	Limitations of Carrefour: the IS.D use case	88
8.2	Overhead	88
8.3	Conclusion	89

In this Chapter, we evaluate Carrefour using 24 different applications taken from the NAS Benchmark suite [30], the Parsec Benchmark suite [29], the ALPBench suite [44] and the Metis Benchmark suite [31]. We use the machines A and B presented in Section 1.4 to perform the evaluation¹. Using these applications, we show that Carrefour always outperforms existing memory management algorithms and never degrades performance – even on applications that do not benefit from memory management. We conclude this chapter with an overview of the overhead of Carrefour and a discussion of the possible hardware evolutions that could be leveraged by Carrefour in order to further reduce its overhead.

8.1 Single-application workloads

8.1.1 Performance comparison

Figures 8.3 and 8.4 present the performance of Carrefour, AutoNUMA and Manual Interleaving compared to Linux on machines A and B. We can see that Carrefour con-

¹We were not able to use machine C for the evaluation because Carrefour requires a custom kernel that supports page replication - contrarily to MemProf that patches a running kernel. Unfortunately machine C is a shared machine and changing its kernel is not allowed.

stantly outperforms AutoNUMA and Manual Interleaving - except on IS.D. Carrefour provides important performance improvement (more than x2) on four applications. The maximum performance degradation of Carrefour compared to Linux is 4% on IS.D on machine B. On other applications the maximum performance degradation is below 2%. In the next subsection, we study the IS.D case in more details.

8.1.2 Performance analysis

In order to understand the reasons for the performance impact of the different policies, we use several metrics on a set of selected applications for which Carrefour improves performance. The profiling results for all applications are available in Appendix A and Appendix B for machine A and machine B respectively (Figures A.2, A.1, A.3, B.2, B.1, and B.3).

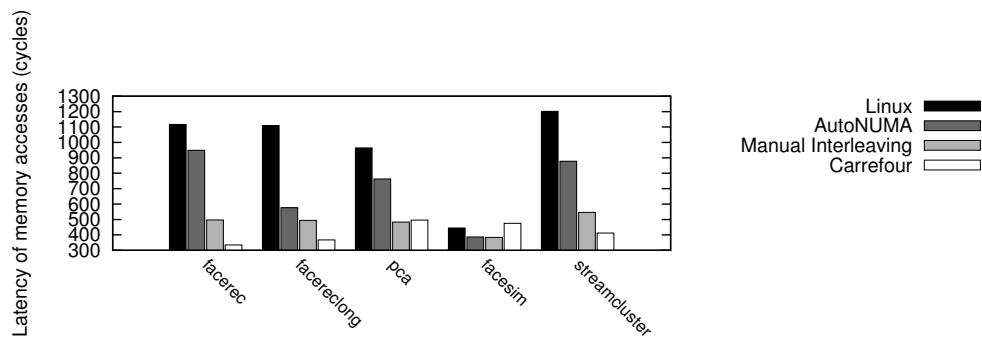

Figure 8.1 – Latency of memory accesses of applications on machine A.

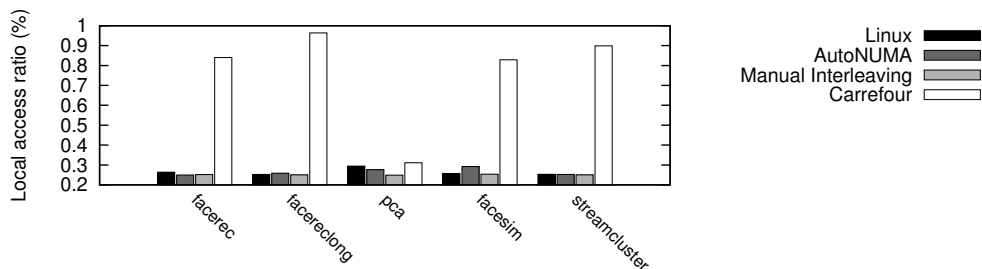

Figure 8.2 – Local Access ratio of applications on machine A.

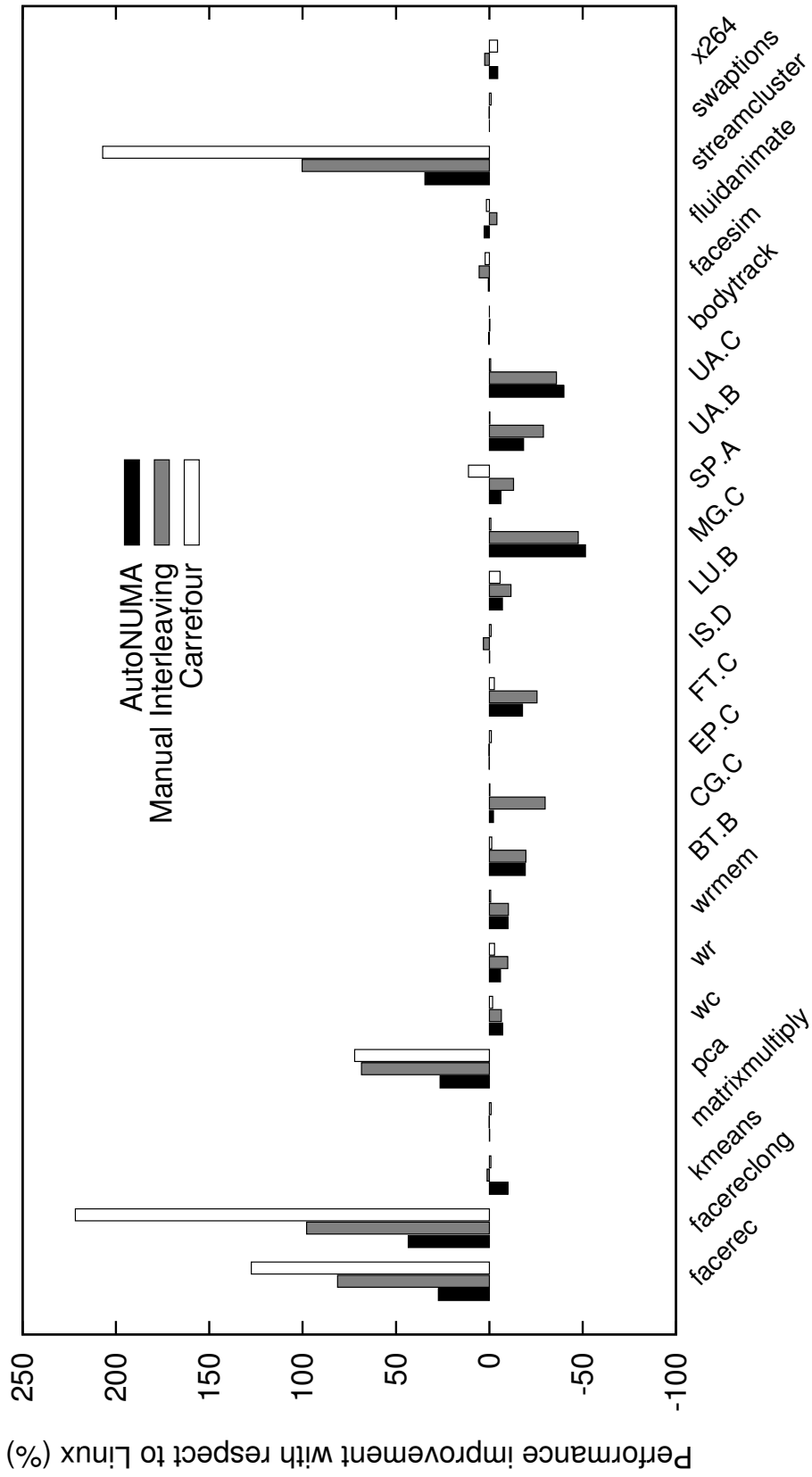

Figure 8.3 – Performance of Carrefour on machine A.

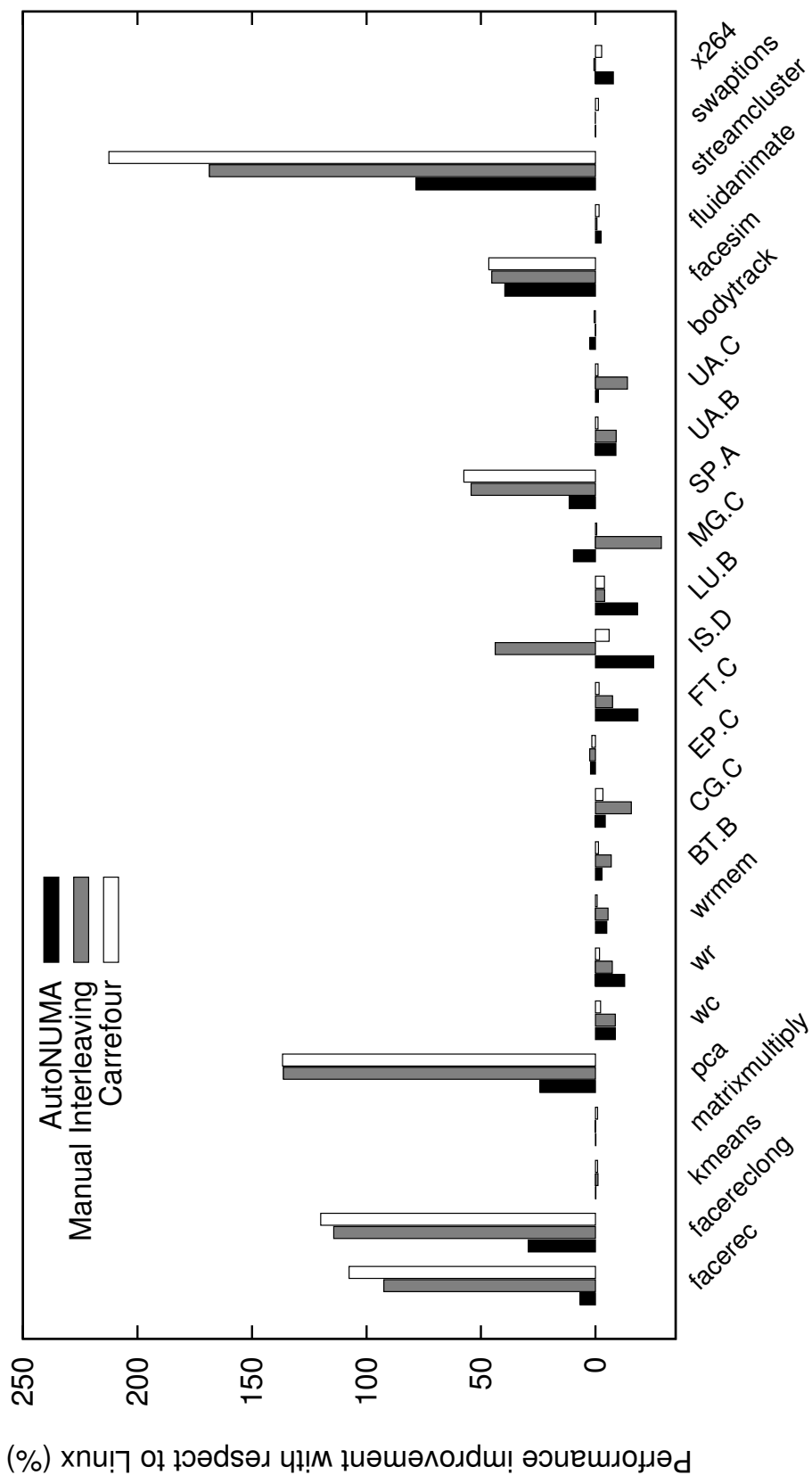

Figure 8.4 – Performance of Carrefour on machine B.

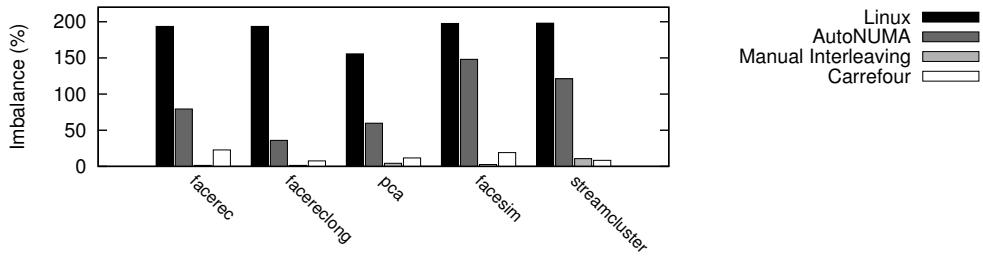

Figure 8.5 – Imbalance of applications on machine A.

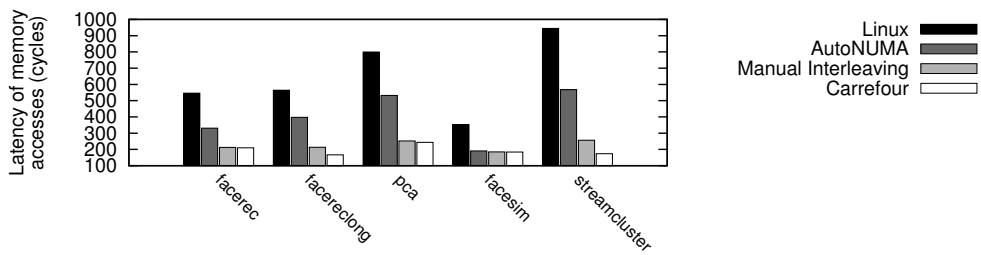

Figure 8.6 – Latency of memory accesses of applications on machine B.

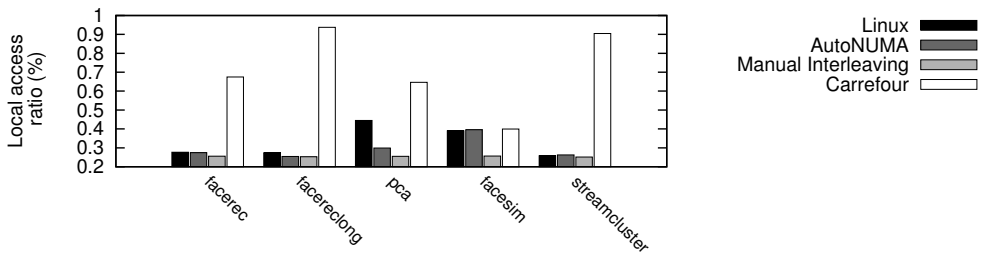

Figure 8.7 – Local Access ratio of applications on machine B.

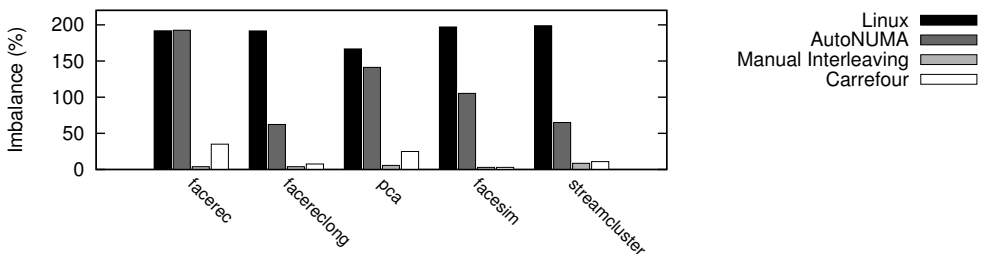

Figure 8.8 – Imbalance of applications on machine B.

In detail, for each studied application, we plot:

- The latency of memory accesses (Figures 8.1 on machine A and 8.6 on machine B). The latency of memory accesses is a good indicator of both contention and locality. If the latency of memory accesses is higher in a configuration X than in a configuration Y, it either means that there is more contention in X than in Y, or that X is performing more remote memory accesses than Y. Note that difference between latency values below 500 for machine A and 200 for machine B are not really significant (i.e., the latency counter is not accurate for applications that access memory with a “low” latency). We observe in Figures 8.1 and 8.6 that Carrefour either reduces the latency or performs as efficiently as the best configuration.
- The local access ratio (Figures 8.2 on machine A and 8.7 on machine B). We can see that Carrefour systematically improves the local access ratio.
- The load imbalance on memory controllers (Figures 8.5 on machine A and 8.8 on machine B). We can see that Carrefour systematically improves the imbalance compared to default Linux. Carrefour doesn’t always achieve a perfect load balance (as Manual Interleaving does) because it also tries to preserve a high local access ratio.

In conclusion, Carrefour much better balances the load on memory controllers than Linux and AutoNUMA. It also has a much higher ratio of local memory accesses than other techniques. This is a consequence of Carrefour judiciously applying the right techniques (interleaving, replication or migration) in places where they are beneficial. Interleaving mostly balances the load; replication and migration in addition to balancing the load improve the local access ratio.

Also note that, contrarily to other techniques, Carrefour never degrades performance. For example, Manual interleaving has a very bad impact on workloads with a high locality because it spreads data randomly on all nodes. Carrefour does a better job because it also maximizes the locality of memory accesses.

8.1.3 Limitations of Carrefour: the IS.D use case

IS.D is an exception among the NAS benchmarks: on machine B (see Figure 8.4), Manual interleaving improves its performance, while Carrefour does not better than default Linux. That is because IS suffers from very short imbalance bursts that we are not able to correct. Figure 8.9 presents the memory access pattern of IS.D observed with a high frequency (hardware counter values are read every 50ms). We can see that all nodes are accessed in turn for short periods of times (a bit less than 1s). When Carrefour tries to balance the load it often reacts “too late” (meaning that the pages that it moves will not be used in the next burst). Moving these pages has a small overhead and does not help improving the local access ratio of IS.D.

8.2 Overhead

Carrefour incurs CPU and memory overhead. The first source of CPU overhead is the periodic IBS profiling. To measure CPU overhead, we compared performance of

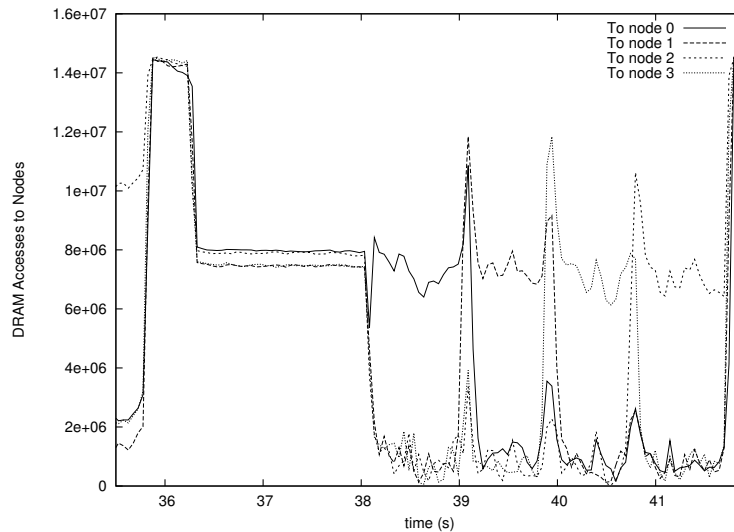

Figure 8.9 – Number of memory accesses performed to each node, with a 50ms resolution. The memory accesses repeat a pattern: first all nodes are equally accessed, then all accesses are done to node 0, then to node 1, then to node 3 and finally to node 2.

Carrefour with Linux on the applications where Carrefour does not yield any performance benefits. We observed an overhead ranging between 0.2% and 4%. Adaptive sampling rate in Carrefour is crucial to keeping this overhead low.

The first source of memory overhead is the allocation of data structures to keep track of profiling data. This overhead is negligible: e.g., 5MB on Machine A with 32GB of RAM. Carrefour’s data structures are pre-allocated on startup to avoid memory allocation during the runtime. Moreover, we limit the number of profiled pages to 30,000 to avoid the cost of managing dynamically sized structures. The second source of memory overhead is memory replication. When enabled, replication introduces a memory footprint overhead of 400MB (353%), 60MB (210%), 60MB (126%) and 614MB (5%) for Streamcluster, FaceRec, FacerecLong and PCA, respectively. On other applications, replication is not enabled by Carrefour.

8.3 Conclusion

We have evaluated Carrefour, a new memory management algorithm for NUMA systems that tries to limit contention on memory controllers and interconnects. We have seen that Carrefour can provide significant performance improvements (up to x3.3). We have seen that Carrefour never degrades performance by more than 4% on applications for which memory management is not required.

However, the challenge in building Carrefour was the need to navigate around the limitations of the performance monitoring units of our hardware as well as the costs of

replicating pages. In this conclusion, we draw some insights on the features that could be integrated into future machines in order to further mitigate the overhead and improve accuracy, efficiency and performance of traffic management algorithms.

First, Carrefour would benefit from hardware profiling mechanisms that sample memory accesses with high precision and low overhead. For instance, it would be useful to have a profiling mechanism that accumulates and aggregates page access statistics in an internal buffer before triggering an interrupt. In this regard, the AMD Lightweight Profiling [70] facility seems a promising evolution of profiling hardware. Unfortunately, LWP is not fully implemented in current Bulldozer processors (e.g., accessed virtual addresses are not recorded), so we were not able to test it.

Second, Carrefour would benefit from dedicated hardware support for memory replication. We believe that there should be interfaces allowing the operating system to indicate to the processor which pages to replicate. The processor would then be in charge of replicating the pages on the nodes accessing it and maintaining consistency between the various replicas (in the same way as it maintains consistency for cache lines). Given that maintaining consistency between frequently written pages is costly, we believe that such processors should also be able to trigger an interrupt when a page is written too frequently. The OS would then decide to keep the page replicated or to revert the replication decision. This hardware support can be made a lot more scalable than cache coherency protocols, because it is not automatic, but controlled by the OS, which, armed with better hardware profiling, will only invoke it for pages that perform very little write sharing. So the actual synchronization protocol would be triggered infrequently.

Conclusion

Modern multicore systems are based on a Non-Uniform Memory Access (NUMA) architecture. We have explained advantages and challenges introduced by these architectures. In this context, our contributions are twofold: (i) we introduced a new profiling tool designed to help developers solve NUMA-issues and (ii) we introduced a new dynamic memory management algorithm that focuses on reducing contention on NUMA machines. These two contributions allowed us to drastically improve the performance of multiple applications (by up to 3.3x). In this chapter, we describe some future research directions that, we believe, would be interesting to follow.

Future research directions

Considering background traffic

MemProf and Carrefour only work on a portion of the traffic that travels through memory buses and interconnect links. Most notably, they do not consider traffic induced by I/Os (e.g., DMA accesses performed by the network interfaces) or by the cache coherence protocol. They also ignore all traffic due to data fetched by the prefetcher but not used by the applications (i.e., useless prefetched data). In some workloads, the impact of this background traffic can be significant. For instance, a network card sending data at 10Gb/s can use up to 45% of an interconnect link of machine A (10Gb/s out of the maximum 22.4Gb/s that the link can sustain). In modern servers that usually have multiple 10Gb NICs [71], the background traffic can create contention and slow down both I/Os and applications running on the machine. Background traffic is likely to increase in the near future, because servers will be equipped with co-processors that will communicate using interconnect links. Future algorithms aiming at managing memory traffic will have to take this traffic into account.

Considering asymmetry in the machine's topology

MemProf and Carrefour consider that all memory buses have the same latency in the absence of contention and the same maximum bandwidth. The same simplification is made for interconnect links. However, multiple machines are built with an asymmetric topology. For instance, one of the links in machine B has half the maximum bandwidth of other links. Machine C is even more asymmetric, i.e., some links are unidirectional (the latency from node X to node Y is not always the same as that from node Y to node

X) and links do not have the same maximum bandwidth. In this context, judiciously choosing the nodes on which an application executes may prove to be important. For instance, if all threads of an application share data, placing the application on two nodes that are interconnected with a high-bandwidth link may perform better than placing it on two nodes interconnected with a low-bandwidth link. As the number of nodes in multicore NUMA machines increases, the interconnect topology is likely to become more and more complex and asymmetric. Considering the topology in a thread or memory placement algorithm is currently an open problem.

Memory placement in virtualized environments

In this thesis, we have focused on applications running in a non-virtualized environment. Virtualized environments introduce multiple challenges. First, memory has to be managed on two levels: the host level and the guest level. If both levels do not communicate on their memory placement decisions, it is likely that they will make contradictory decisions or perform redundant work. Second, workloads in virtualized environments may be more diverse and unpredictable than those running in non-virtualized environments. For instance, in a Cloud, a NUMA machine may run multiple VMs, each executing workloads of different clients. Designing heuristics that work in these situations might prove to be more challenging than designing heuristics for non-virtualized environments.

Bibliography

- [1] SFU, (Simon Fraser University). <http://www.sfu.ca/>.
- [2] R. Lachaize, B. Lepers, and V. Quéma, “MemProf: A Memory Profiler for NUMA Multicore Systems,” in *USENIX ATC*, 2012.
- [3] M. Dashti, A. Fedorova, J. Funston, F. Gaud, R. Lachaize, B. Lepers, V. Quema, and M. Roth, “Traffic management: a holistic approach to memory placement on numa systems,” in *Proceedings of the eighteenth international conference on Architectural support for programming languages and operating systems*, ser. ASPLOS ’13, 2013, pp. 381–394.
- [4] S. Blagodurov, S. Zhuravlev, M. Dashti, and A. Fedorova, “A case for NUMA-Aware Contention Management on Multicore Systems,” in *Proceedings of USENIX ATC*, 2011.
- [5] B. Verghese, S. Devine, A. Gupta, and M. Rosenblum, “Operating system support for improving data locality on CC-NUMA compute servers,” in *ASPLOS*, 1996.
- [6] S. Boyd-Wickizer, R. Morris, and M. F. Kaashoek, “Reinventing scheduling for multicore systems,” in *Proceedings of the 12th conference on Hot topics in operating systems*, ser. HotOS’09. Berkeley, CA, USA: USENIX Association, 2009, pp. 21–21.
- [7] D. Tam, R. Azimi, and M. Stumm, “Thread Clustering: Sharing-Aware Scheduling on SMP-CMP-SMT Multiprocessors,” in *EuroSys*, 2007.
- [8] S. Blagodurov, S. Zhuravlev, and A. Fedorova, “Contention-aware scheduling on multicore systems,” *ACM Trans. Comput. Syst.*, vol. 28, pp. 8:1–8:45, 2010.
- [9] AutoNUMA: the other approach to NUMA scheduling, LWN.net, Mar. 2012, <http://lwn.net/Articles/488709/>.
- [10] A. Pesterev, J. Strauss, N. Zeldovich, and R. T. Morris, “Improving network connection locality on multicore systems,” in *Proceedings of the 7th ACM european conference on Computer Systems*, ser. EuroSys ’12, New York, NY, USA, 2012, pp. 337–350.
- [11] E. Z. Zhang, Y. Jiang, and X. Shen, “Does cache sharing on modern cmp matter to the performance of contemporary multithreaded programs?” in *PPOPP*, 2010.

-
- [12] A. Pesterev, N. Zeldovich, and R. T. Morris, "Locating cache performance bottlenecks using data profiling," in *EuroSys*, 2010.
- [13] R. Knauerhase, P. Brett, B. Hohlt, T. Li, and S. Hahn, "Using OS Observations to Improve Performance in Multicore Systems," *IEEE Micro*, vol. 28, no. 3, pp. pp. 54–66, 2008.
- [14] J.-P. Lozi, F. David, G. Thomas, J. Lawall, and G. Muller, "Remote core locking: migrating critical-section execution to improve the performance of multi-threaded applications," in *Proceedings of the 2012 USENIX conference on Annual Technical Conference*, ser. USENIX ATC'12. Berkeley, CA, USA: USENIX Association, 2012, pp. 6–6.
- [15] P. Conway, N. Kalyanasundharam, G. Donley, K. Lepak, and B. Hughes, "Cache hierarchy and memory subsystem of the amd opteron processor," *Micro, IEEE*, vol. 30, no. 2, pp. 16–29, 2010.
- [16] H. Kang and J. L. Wong, "To hardware prefetch or not to prefetch?: a virtualized environment study and core binding approach," in *Proceedings of the eighteenth international conference on Architectural support for programming languages and operating systems*, ser. ASPLOS '13, 2013, pp. 357–368.
- [17] W. A. Wulf and S. A. McKee, "Hitting the memory wall: implications of the obvious," *SIGARCH Comput. Archit. News*, vol. 23, no. 1, pp. 20–24, Mar. 1995.
- [18] B. Veal and A. Foong, "Performance Scalability of a Multi-Core Web Server," in *Proceedings of Architectures for Networking and Communications Systems (ANCS)*, December 2007.
- [19] Y. Zhao, J. Shi, K. Zheng, H. Wang, H. Lin, and L. Shao, "Allocation wall: a limiting factor of java applications on emerging multi-core platforms," in *Proceedings of the 24th ACM SIGPLAN conference on Object oriented programming systems languages and applications*, ser. OOPSLA '09, 2009, pp. 361–376.
- [20] A. Cox, R. Fowler, and J. Veenstra, *Interprocessor Invocation on a NUMA Multiprocessor*, ser. Department of Computer Science: Technical report. University of Rochester, Department of Computer Science, 1990. [Online]. Available: <http://books.google.fr/books?id=0FFMcgAACAAJ>
- [21] L. Benini, E. Flamand, D. Fuin, and D. Melpignano, "P2012: building an ecosystem for a scalable, modular and high-efficiency embedded computing accelerator," in *Proceedings of the Conference on Design, Automation and Test in Europe*, ser. DATE '12. San Jose, CA, USA: EDA Consortium, 2012, pp. 983–987.
- [22] M. Awasthi, D. Nellans, K. Sudan, R. Balasubramonian, and A. Davis, "Handling the problems and opportunities posed by multiple on-chip memory controllers," in *PACT*, 2010.
- [23] S. Blagodurov, S. Zhuravlev, M. Dashti, and A. Fedorova, "A Case for NUMA-aware Contention Management on Multicore Systems," in *USENIX ATC*, 2011.

-
- [24] W. Bolosky, R. Fitzgerald, and M. Scott, “Simple but Effective Techniques for NUMA Memory Management,” in *SOSP*, 1989.
- [25] R. P. LaRowe, Jr., C. S. Ellis, and M. A. Holliday, “Evaluation of NUMA Memory Management Through Modeling and Measurements,” *IEEE TPDS*, vol. 3, no. 6, pp. 686–701, 1992.
- [26] T. Brecht, “On the Importance of Parallel Application Placement in NUMA Multiprocessors,” in *USENIX SEDMS*, 1993.
- [27] L. Tang, J. Mars, X. Zhang, R. Hagmann, R. Hundt, and E. Tune, “Optimizing google’s warehouse scale computers: The numa experience,” in *Nineteenth International Symposium on High-Performance Computer Architecture*, IEEE Computer Society, Customer Service Center, 10662 Los Vaqueros Circle, P.O. Box 3014, Los Alamitos, CA 90720-1314, 2013.
- [28] L. Gidra, G. Thomas, J. Sopena, and M. Shapiro, “A study of the scalability of stop-the-world garbage collectors on multicores,” in *Proceedings of the eighteenth international conference on Architectural support for programming languages and operating systems*, ser. ASPLOS ’13, 2013, pp. 229–240.
- [29] C. Bienia, S. Kumar, J. P. Singh, and K. Li, “The PARSEC Benchmark Suite: Characterization and Architectural Implications,” in *PACT*, 2008.
- [30] D. H. Bailey, E. Barszcz, and J. T. Barton et al., “The NAS Parallel Benchmarks—Summary and Preliminary Results,” in *Supercomputing*, 1991.
- [31] Metis MapReduce Library, <http://pdos.csail.mit.edu/metis/>.
- [32] A. Baumann, P. Barham, P.-E. Dagand, T. Harris, R. Isaacs, S. Peter, T. Roscoe, A. Schüpbach, and A. Singhanian, “The Multikernel: A New OS Architecture for Scalable Multicore Systems,” in *SOSP*, 2009.
- [33] S. Boyd-Wickizer, M. F. Kaashoek, R. Morris, and N. Zeldovich, “A software approach to unifying multicore caches,” Tech. Rep. MIT-CSAIL-TR-2011-032, 2011.
- [34] B. Gamsa, O. Krieger, and M. Stumm, “Tornado: Maximizing Locality and Concurrency in a Shared Memory Multiprocessor Operating System,” in *OSDI*, 1999.
- [35] Z. Metreveli, N. Zeldovich, and F. Kaashoek, “Cphash: a cache-partitioned hash table,” in *PPoPP*, 2012.
- [36] I. Pandis, R. Johnson, N. Hardavellas, and A. Ailamaki, “Data-oriented transaction execution,” *Proc. VLDB Endow.*, vol. 3, pp. 928–939, September 2010.
- [37] T.-I. Salomie, I. E. Subasu, J. Giceva, and G. Alonso, “Database engines on multicores, why parallelize when you can distribute?” in *EuroSys*, 2011.
- [38] X. Song, H. Chen, R. Chen, Y. Wang, and B. Zang, “A case for scaling applications to many-core with OS clustering,” in *EuroSys*, 2011.
- [39] H. M. C. Consortium, <http://www.hybridmemorycube.org/>.
- [40] Oprofile, <http://oprofile.sourceforge.net/>.
- [41] perf: Linux profiling with performance counters, https://perf.wiki.kernel.org/index.php/Main_Page/.

-
- [42] Intel VTune Amplifier XE, <http://software.intel.com/en-us/intel-vtune-amplifier-xe>.
- [43] C. Mccurdy and J. Vetter, "Memphis: Finding and fixing numa-related performance problems on multi-core platforms," in *In Proceedings of ISPASS*, 2010.
- [44] CSU Face Identification Evaluation System, <http://www.cs.colostate.edu/evalfacerec/index10.php>.
- [45] PARSEC Benchmark Suite, <http://parsec.cs.princeton.edu/>.
- [46] S. Boyd-Wickizer, A. Clements, Y. Mao, A. Pesterev, M. F. Kaashoek, R. Morris, and N. Zeldovich, "An Analysis of Linux Scalability to Many Cores," in *Proceedings of OSDI*, October 2010.
- [47] Apache, The Apache HTTP Server Project. <http://httpd.apache.org>.
- [48] BIOS and Kernel Developer's Guide (BKDG) For AMD Family 10h Processors, http://support.amd.com/us/Processor_TechDocs/31116.pdf.
- [49] S. Bhatia, A. Kumar, M. E. Fiuczynski, and L. Peterson, "Lightweight, high-resolution monitoring for troubleshooting production systems," in *Proceedings of the 8th USENIX conference on Operating systems design and implementation*, ser. OSDI'08. Berkeley, CA, USA: USENIX Association, 2008, pp. 103–116.
- [50] L. Soares and M. Stumm, "Flexsc: flexible system call scheduling with exceptionless system calls," in *Proceedings of the 9th USENIX conference on Operating systems design and implementation*, ser. OSDI'10. Berkeley, CA, USA: USENIX Association, 2010, pp. 1–8.
- [51] P. A. G. for Intel Core i7 Processor and I. X. . processors, http://software.intel.com/sites/products/collateral/hpc/vtune/performance_analysis_guide.pdf.
- [52] SystemTap, <http://sourceware.org/systemtap/>.
- [53] C.-K. Luk, R. Cohn, R. Muth, H. Patil, A. Klauser, G. Lowney, S. Wallace, V. J. Reddi, and K. Hazelwood, "Pin: Building Customized Program Analysis Tools with Dynamic Instrumentation," in *PLDI*, 2005.
- [54] M. M. Bach, M. Charney, R. Cohn, E. Demikhovskiy, T. Devor, K. Hazelwood, A. Jaleel, C.-K. Luk, G. Lyons, H. Patil, and A. Tal, "Analyzing parallel programs with pin," *Computer*, vol. 43, no. 3, pp. 34–41, Mar. 2010.
- [55] X. Zhang, S. Dwarkadas, and K. Shen, "Towards practical page coloring-based multicore cache management," in *Proceedings of the 4th ACM European conference on Computer systems*, ser. EuroSys '09, 2009, pp. 89–102.
- [56] F. Gaud, R. Lachaize, B. Lepers, G. Muller, and V. Quéma, "Scheduling applications on numa multicore platforms with an asymmetric interconnect topology."
- [57] Likwid-Peerfctr, <https://code.google.com/p/likwid/wiki/LikwidPerfCtr>.
- [58] Miniprof, <https://github.com/fgaud/Miniprof>.
- [59] AMD CodeAnalyst Performance Analyzer, <http://developer.amd.com/tools-and-sdks/heterogeneous-computing/archived-tools/amd-codeanalyst-performance-analyzer/>.

-
- [60] M. lap Li, R. Sasanka, S. V. Adve, Y. kuang Chen, and E. Debes, “The ALPBench Benchmark Suite for Complex Multimedia Applications,” in *Proceedings of ISWC*, 2005, pp. 34–45.
- [61] C. Bienia and K. Li, “PARSEC 2.0: A New Benchmark Suite for Chip-Multiprocessors,” in *Proceedings of the 5th Annual Workshop on Modeling, Benchmarking and Simulation*, 2009.
- [62] SPEC, (Standard Performance Evaluation Corporation). SPECweb2005. <http://www.spec.org/web2005/>.
- [63] A. Merkel, J. Stoess, and F. Belloso, “Resource-Conscious Scheduling for Energy Efficiency on Multicore Processors,” in *EuroSys*, 2010.
- [64] S. Zhuravlev, S. Blagodurov, and A. Fedorova, “Addressing Contention on Multicore Processors via Scheduling,” in *ASPLOS*, 2010.
- [65] R. E. Kessler and M. D. Hill, “Page placement algorithms for large real-indexed caches,” *ACM Trans. Comput. Syst.*, vol. 10, no. 4, pp. 338–359, Nov. 1992.
- [66] NUMA Support in Windows, [http://msdn.microsoft.com/en-us/library/windows/desktop/aa363804\(v=vs.85\).aspx](http://msdn.microsoft.com/en-us/library/windows/desktop/aa363804(v=vs.85).aspx).
- [67] J. Mauro and R. McDougall, *Solaris Internals (2nd Edition)*. Upper Saddle River, NJ, USA: Prentice Hall PTR, 2006.
- [68] M. K. Dashti, “Implementation of resource contention management in the linux kernel for multicore numa systems,” Ph.D. dissertation, Applied Sciences: School of Computing Science, 2012.
- [69] J. Ousterhout, P. Agrawal, D. Erickson, C. Kozyrakis, J. Leverich, D. Mazières, S. Mitra, A. Narayanan, G. Parulkar, M. Rosenblum, S. M. Rumble, E. Stratmann, and R. Stutsman, “The case for ramclouds: scalable high-performance storage entirely in dram,” *SIGOPS Oper. Syst. Rev.*, vol. 43, no. 4, pp. 92–105, Jan. 2010.
- [70] AMD64 Technology Lightweight Profiling Specification, Aug. 2010, http://support.amd.com/us/Processor_TechDocs/43724.pdf.
- [71] M. Dobrescu, N. Egi, K. Argyraki, B.-G. Chun, K. Fall, G. Iannaccone, A. Knies, M. Manesh, and S. Ratnasamy, “Routebricks: exploiting parallelism to scale software routers,” in *Proceedings of the ACM SIGOPS 22nd symposium on Operating systems principles*, ser. SOSP ’09, 2009.

List of Figures

1	A NUMA system with 4 nodes and 4 cores per node.	1
1.1	Physical to virtual memory mapping. The operating system is in charge of maintaining the mapping between virtual memory regions and physical memory.	5
1.2	Page table format. The operating system segments the addressable space in “pages”. The mapping between virtual addresses of pages and their physical address is stored in a page table. On current x86_64 systems, the page table has to be a 4-level hierarchical translation table.	6
1.3	Caches. Modern multicore processors often have multiple levels of cache. The latency required to access a data in cache is much lower than that of accessing data in DRAM.	6
1.4	Inter-core communications. When two cores share a cache (e.g., a L3), they communicate via this cache. Otherwise, they communicate using interconnect links.	7
1.5	UMA. All processors share a single DRAM controller.	10
1.6	NUMA. Cores are grouped into “nodes”. Each node has a DRAM controller.	11
1.7	Topology of the machines used in the evaluations. Some links in machine C are unidirectional.	13
1.8	Impact of remote memory accesses on performance of various applications.	15
1.9	Impact of contention on performance of various applications.	15
1.10	Fat tree architecture. NUMA nodes are interconnected via multiples routers. Routers can be interconnected using high bandwidth interconnect links.	20
3.1	Overhead of IBS, depending on IBS sampling frequency, with the simplest IBS interrupt handler possible.	32
3.2	Output of perf report (a) and perf annotate (b) on FaceRec. (a) The transposeMultiplyMatrixL function represents 83% of the cycles and (b) most of the time is spent in a loop that multiplies two matrices.	41
4.1	The two types of flows built by MemProf. There is (a) a Thread Event Flow per profiled thread, and (b) an Object Event Flow per object accessed during the profiling session.	47

4.2	Implementation of MemProf. MemProf performs two tasks: event collection (online) and flow construction (offline). Due to space restrictions, we only present the most important fields of the collected events.	48
6.1	Algorithm used by Verghese et al. [5]. This decision tree is applied on all pages accessed in memory.	69
7.1	Workflow of Carrefour. The two boxes in bold (IBS sampling and per page decisions) represent the costly parts of the workflow.	74
7.2	Algorithm used by Carrefour. This decision tree is applied on all pages accessed in memory. The “Migrate” and “Interleave” boxes will only result in migrations or interleaving if migration or interleaving, respectively, are enabled.	79
8.1	Latency of memory accesses of applications on machine A.	84
8.2	Local Access ratio of applications on machine A.	84
8.3	Performance of Carrefour on machine A.	85
8.4	Performance of Carrefour on machine B.	86
8.5	Imbalance of applications on machine A.	87
8.6	Latency of memory accesses of applications on machine B.	87
8.7	Local Access ratio of applications on machine B.	87
8.8	Imbalance of applications on machine B.	87
8.9	Number of memory accesses performed to each node, with a 50ms resolution. The memory accesses repeat a pattern: first all nodes are equally accessed, then all accesses are done to node 0, then to node 1, then to node 3 and finally to node 2.	89
A.1	Local Access ratio of applications on machine A.	104
A.2	Latency of memory accesses on machine A.	105
A.3	Imbalance on machine A.	106
B.1	Local Access ratio of applications on machine B.	108
B.2	Latency of memory accesses on machine B.	109
B.3	Imbalance on machine B.	110

List of Tables

1.1	Comparison between Hypertransport (AMD) and QuickPath Interconnect (Intel) technologies. The difference between the maximum bandwidth supported by the specification and the observed bandwidth is due to links not using the maximum width (e.g., current AMD processors use 8 or 16 bit links) or not working at their maximum frequency. . . .	8
1.2	Main characteristics of the machines used in the evaluations.	12
1.3	Non-exhaustive list of workloads (lines) and NUMA optimizations (columns). A tick means that the NUMA optimization may make sense for the given workload.	19
3.1	Event 1E0 counts memory accesses done from the monitoring node to others nodes. The destination nodes are controlled using the unit mask. When set to 00, the event counts nothing. When set to 01, the event only counts memory accesses from the monitoring node to node 0. When set to FF, the event counts memory accesses from the monitoring node to all other nodes.	30
3.2	Information provided by IBS on a tagged instruction.	31
5.1	Functions performing most remote memory accesses in FaceRec. . . .	54
5.2	Objects remotely accessed in FaceRec.	55
5.3	Functions performing most remote memory accesses in Streamcluster.	56
5.4	Objects remotely accessed in Streamcluster.	57
5.5	Functions performing remote memory accesses in Psearchy.	58
5.6	Types of the main objects that are remotely accessed in Psearchy. . . .	58
5.7	Top functions performing remote memory accesses in the Apache/PHP stack.	59
6.1	Summary of optimizations and reason why they do not work in some workloads.	72
7.1	Influence of the period at which Carrefour runs on the performance of Streamcluster.	75
7.2	(a) Metrics collected using Hardware Counters and kernel statistics. (b) Metrics collected using IBS.	76
7.3	Influence of the number of pages considered by Carrefour on the performance of Streamcluster.	77

7.4 Cost of per page decisions in Carrefour. 80



Performance analysis of Carrefour on machine A

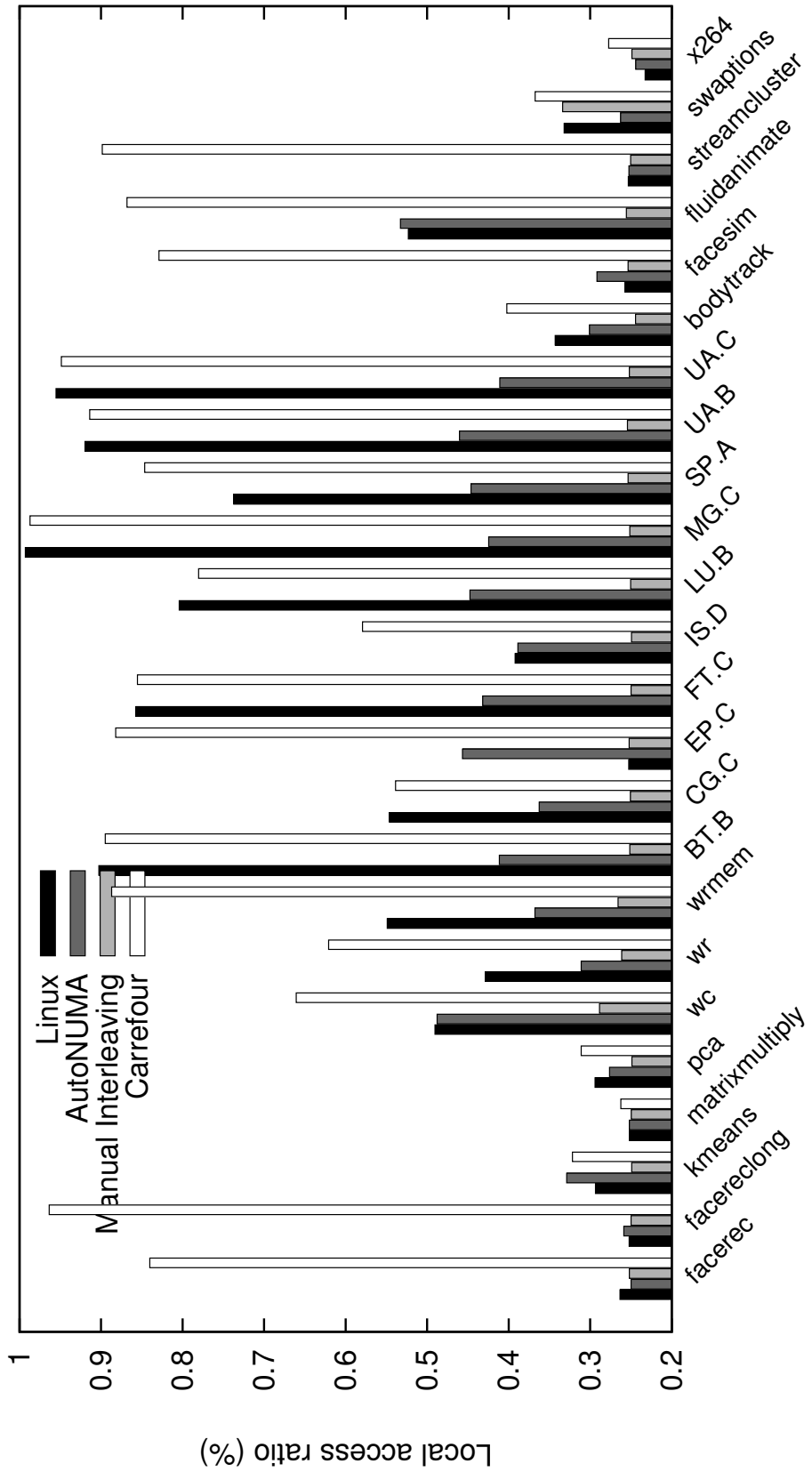

Figure A.1 – Local Access ratio of applications on machine A.

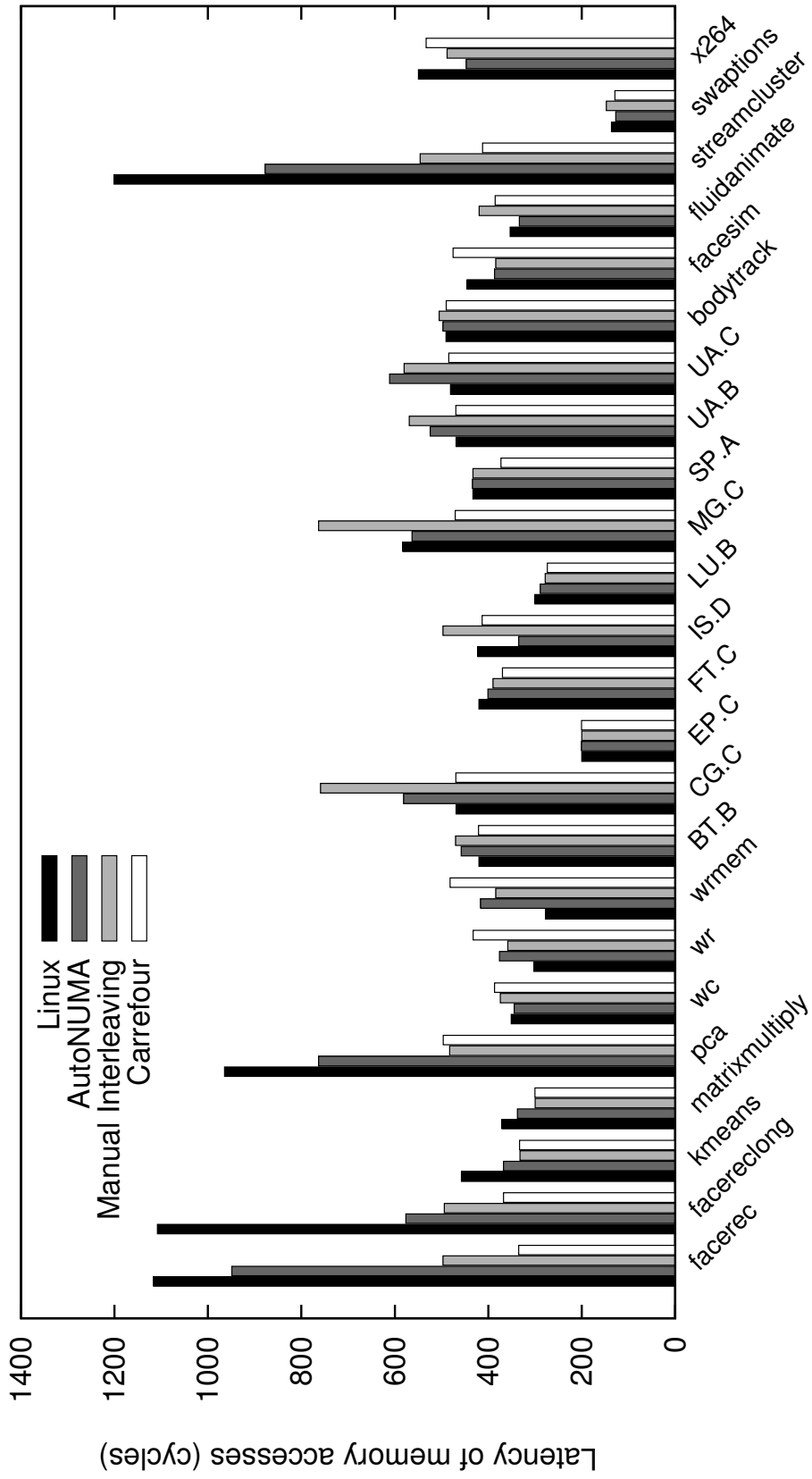

Figure A.2 – Latency of memory accesses on machine A.

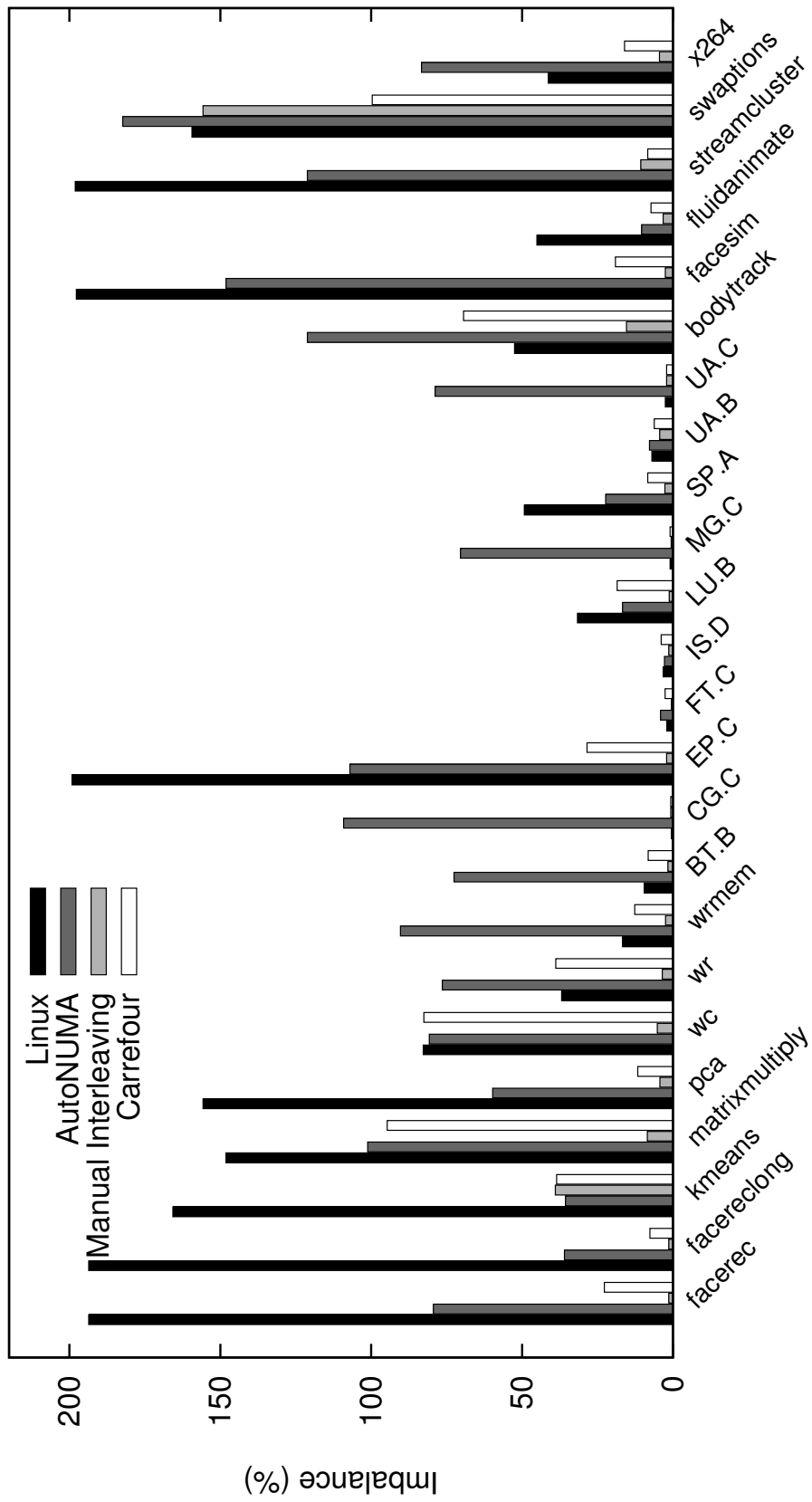

Figure A.3 – Imbalance on machine A.



Performance analysis of Carrefour on machine B

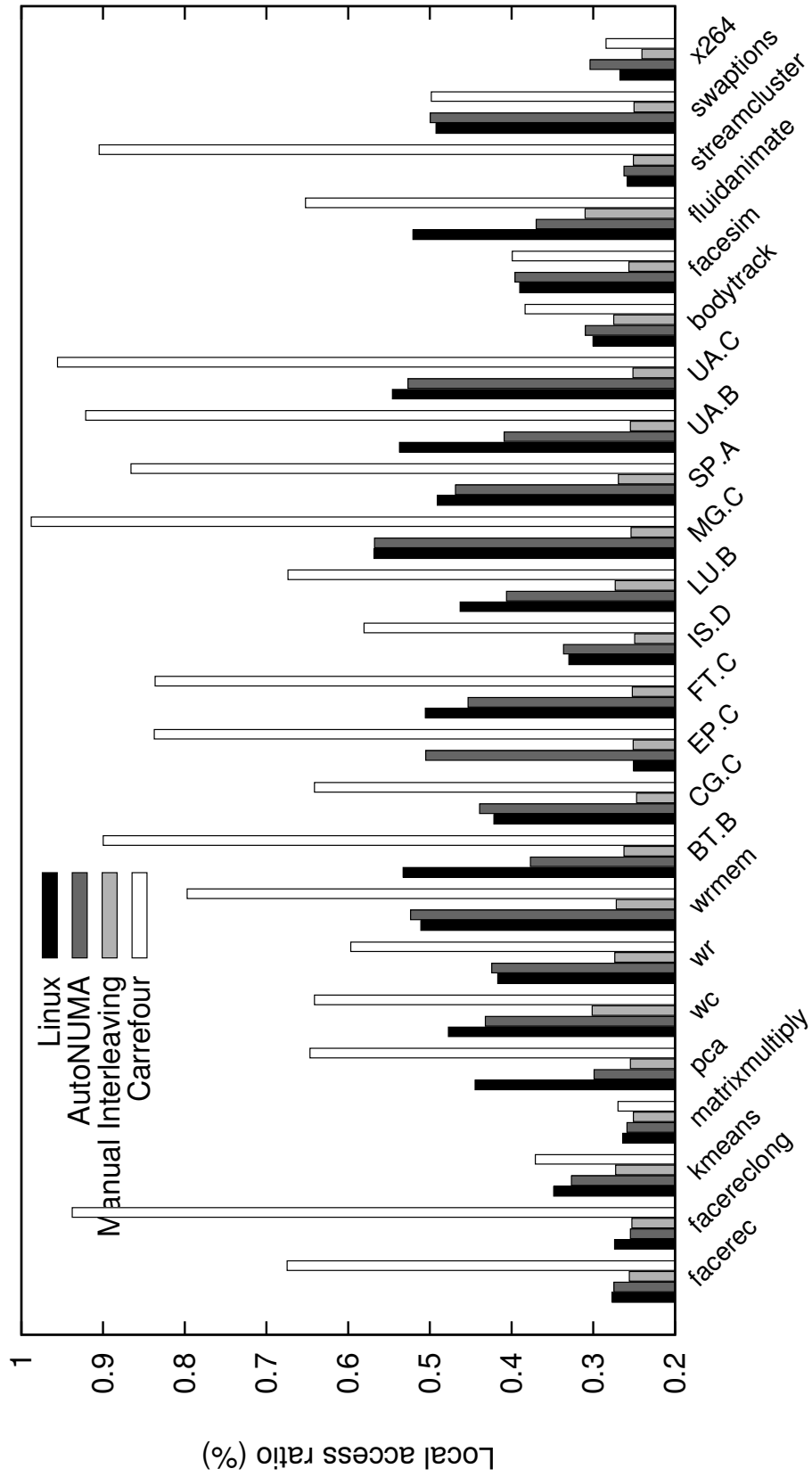

Figure B.1 – Local Access ratio of applications on machine B.

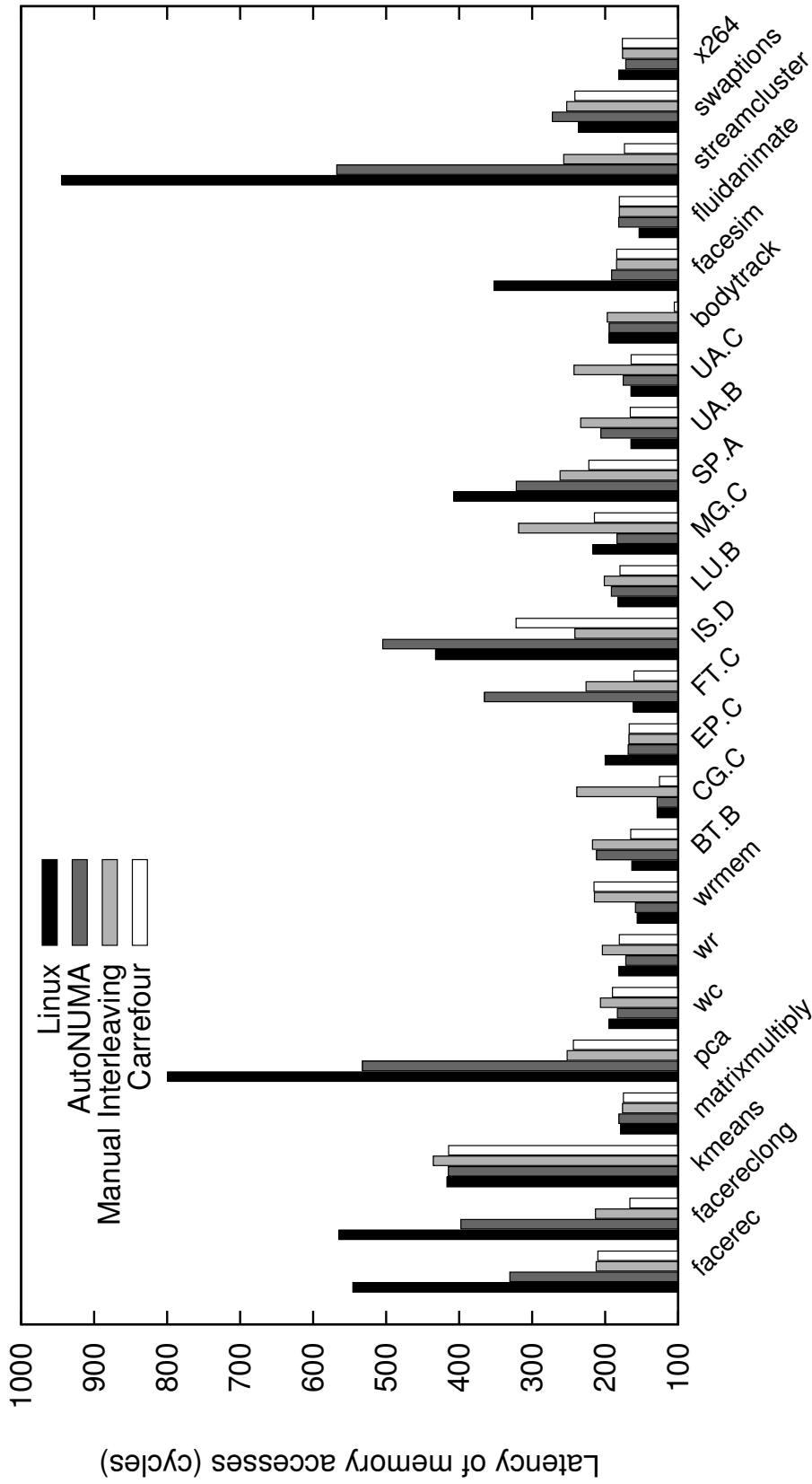

Figure B.2 – Latency of memory accesses on machine B.

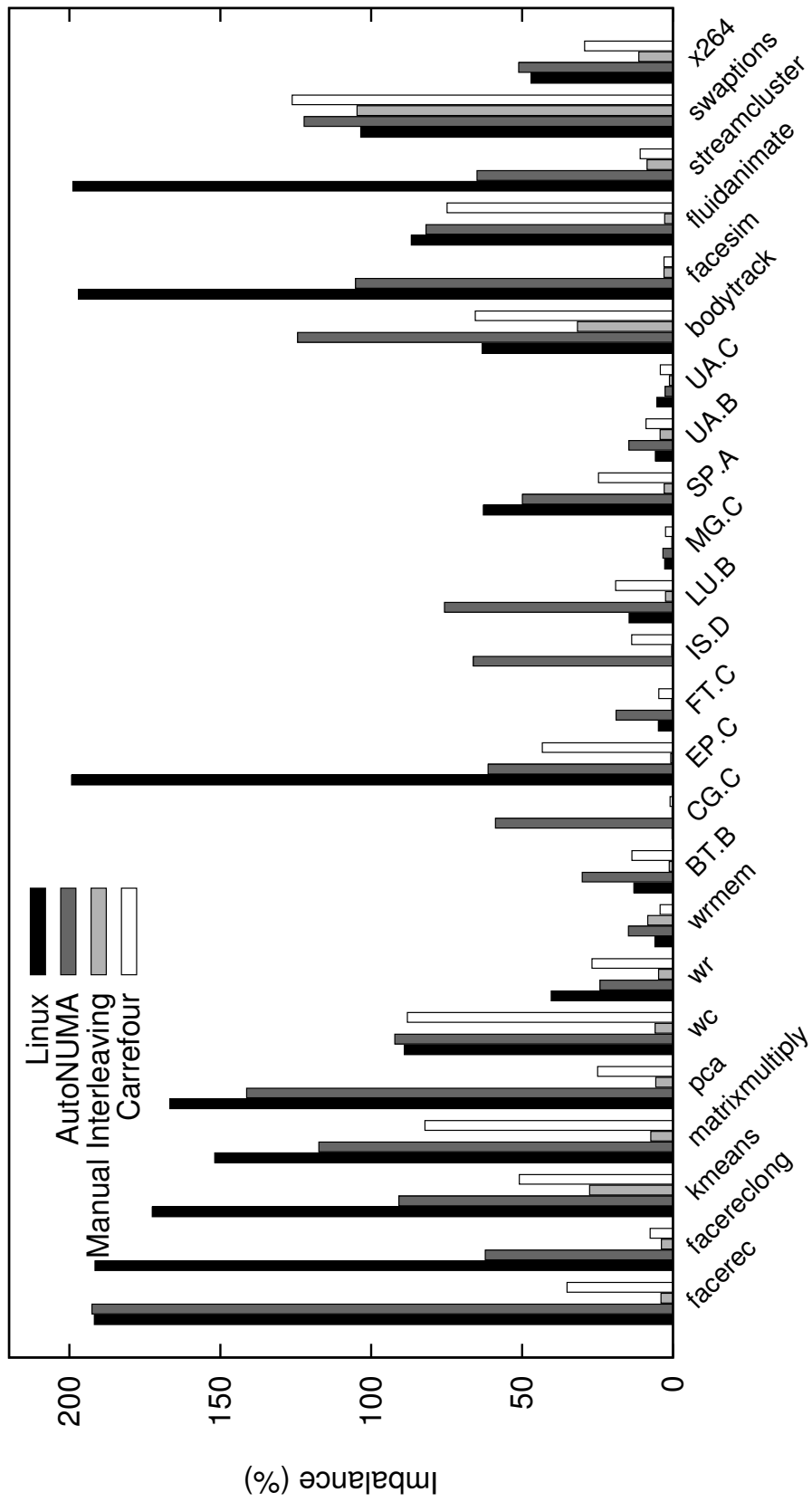

Figure B.3 – Imbalance on machine B.
